



# COMPAX3 SERVO DRIVE





#### **WARNING – USER RESPONSIBILITY**

**FAILURE OR IMPROPER SELECTION OR IMPROPER USE OF THE PRODUCTS DESCRIBED HEREIN OR RELATED ITEMS CAN CAUSE DEATH, PERSONAL INJURY AND PROPERTY DAMAGE.**

- This document and other information from Parker-Hannifin Corporation, its subsidiaries and authorized distributors provide product or system options for further investigation by users having technical expertise.
- The user, through its own analysis and testing, is solely responsible for making the final selection of the system and components and assuring that all performance, endurance, maintenance, safety and warning requirements of the application are met. The user must analyze all aspects of the application, follow applicable industry standards, and follow the information concerning the product in the current product catalog and in any other materials provided from Parker or its subsidiaries or authorized distributors.
- To the extent that Parker or its subsidiaries or authorized distributors provide component or system options based upon data or specifications provided by the user, the user is responsible for determining that such data and specifications are suitable and sufficient for all applications and reasonably foreseeable uses of the components or systems.

#### **SALE CONDITIONS**

The items described in this document are available for sale by Parker Hannifin Corporation, its subsidiaries or its authorized distributors. Any sale contract entered into by Parker will be governed by the provisions stated in Parker's standard terms and conditions of sale (copy available upon request).

## Table of Contents

Overview .....	5
System Layout .....	6
Innovative, Flexible Device Technology .....	8
Control Technology .....	10
Safety Technology .....	11
Device Technologies .....	12
Technical Characteristics .....	18
Technical Data .....	18
Safety Technology .....	19
Positioning .....	19
Supported Motor and Feedback Systems .....	20
Ambient Conditions .....	20
Ports .....	21
Standards and Conformance .....	21
Dimensions .....	22
Accessories and Options .....	23
Software and Tools .....	23
Programming .....	23
Signal Analysis for the System Identification .....	24
Order Code .....	25
Devices: Compax3 .....	25
Accessories .....	26



If you have questions about the products contained in this catalog, or their applications, please contact:  
**Parker Hannifin EMEA Sàrl European Headquarters**  
[parker.com/msgc](http://parker.com/msgc)



# INTELLIGENT SERVO DRIVE COMPAX3

## Overview

### Description

Compax3 is Parker Hannifin's global servo drive. The drive series includes single and multi axis drives as well as hydraulic controllers. It features a power range from 1 to 109 kVA.

The servo drives are completely developed and manufactured in Germany. An additional Compax3 production site was established in the US. As a global servo drive controller, Compax3 is of course available all over the world. Service and support sites are located in the vicinity of all major industry locations - worldwide. The "Parker Authorized Distribution Partners" do play an important role in this context - well-trained and experienced application and support specialists will provide the necessary professional support in any situation.



Compax3H  
High Power  
High Performance  
Servo Drive

Compax3S  
High Performance  
Servo Drive

### Features

#### Hardware

- Power range from 1 to 109 kW
- 1 encoder output / 1 encoder input
- 8 digitale inputs / 4 digital outputs
- 2 analog inputs (14 Bit)
- 2 analog outputs (8 Bit)
- Several fieldbuses
- Extensive safety technology

#### Technology Functions

- I10T10: Drive control via: velocity/torque control, step/direction input, encoder input
- I12T11: Positioning via digital I/Os, RS232/RS485, absolute/relative positioning, registration mark related positioning, electronic gearbox, dynamic positioning
- T30: Programming based on IEC61131-3 with CoDeSys
- PLCopen function modules
  - IEC61131-3 - standard modules
  - C3-specific function modules
- T40: T30 functionality + cam function

### Technical Characteristics - Overview

Device:	Current [A]		Supply voltage	Power [kVA]
	I <sub>cont.</sub>	I <sub>peak</sub> (<5 s)		
<b>Compax3</b>				
S025V2	2.5	5.5	1 * 230/240 VAC	1.0
S063V2	6.3	12.6		2.5
S100V2	10	20	3 * 230/240 VAC	4.0
S015V4	1.5	4.5		1.25
S038V4	3.8	9.0		3.1
S075V4	7.5	15	3 * 400/480 VAC	6.2
S150V4	15	30		11.5
S300V4 <sup>(1)</sup>	30	60		25.0
H090V4	90	135		70.0
H125V4	125	187.5		91.0
H155V4	155	232.5		109.0

<sup>(1)</sup> Operation with capacitor module ModulC4.

# System Layout

## Ethernet

Parker Automation Controller



Communication channel



**Compax3S**  
High Performance  
Servo Drive



**Compax3H**  
High Power  
High Performance  
Servo Drive



Synchronous Servo Motors

Precision Actuators

Handling Actuators

Direct drives

## Parker Automation Tools

IEC 61131-3  
 PLCopen  
 Data handling  
 Visualization  
 Communication (Process Control)  
 Access to all components  
 Project management

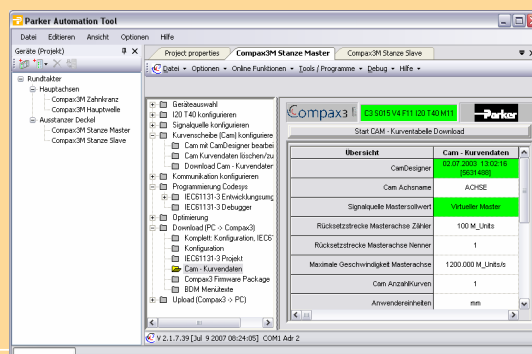

Communication  
 Multi-axis tool  
 C3 ServoManager  
 Drive Interface

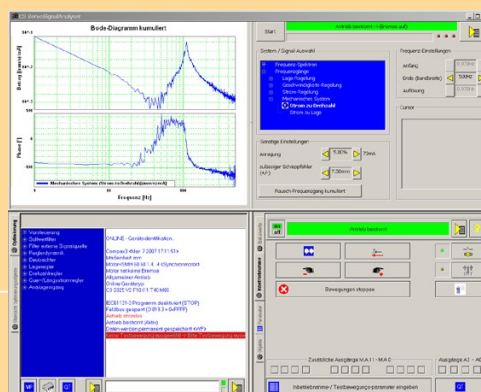

IEC 61131-3  
 PLCopen  
 CamDesigner  
 Optimization  
 Setup  
 Diagnosis / Analysis / Maintenance  
 Oscilloscope

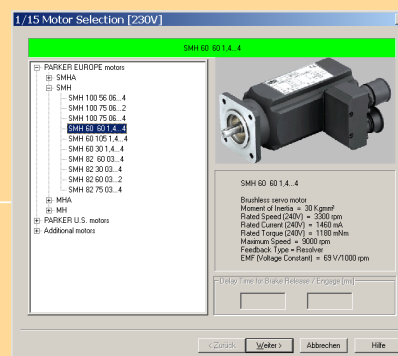

MotorManager  
 Motor library  
 Actuator library

Sizing Tool  
 SERVOSoft® (available on request)

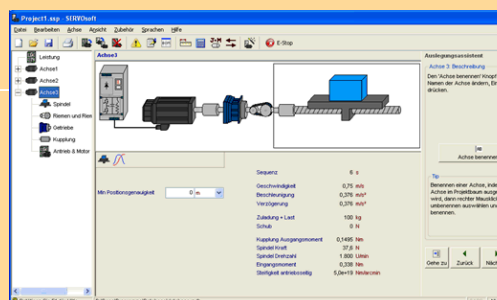

## PC Software



## Software / Tools

Simple and efficient use of a modern and complex automation component offering high functionality such as Compax3 is guaranteed by an intuitively operable software tool. The specially designed "Parker Integrated Engineering Tool". Integral components of this software package are:

- Multi axis system management
- ServoManager
- MotorManager
- ActuatorManager
- HydraulicsManager
- CamDesigner
- IEC 61131-3 / CoDeSys – programming environment
- IEC 61131-3 – Debugger

This software tool supports the user in the configuration, the setup and optimization, the programming as well as the maintenance of all Compax3 devices.

("Software and Tools" see page 22)

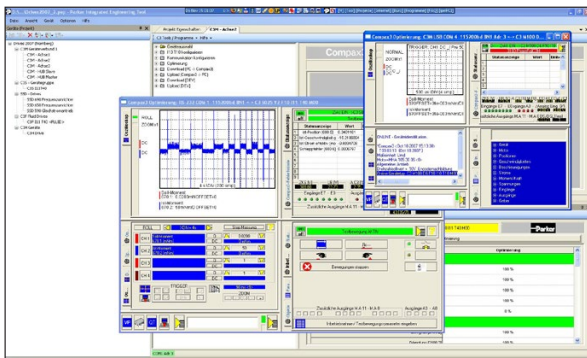

## Electromechanical overall solutions

Electromechanical system solutions play a special role today. Parker Hannifin is not only the manufacturer of modern drive and control technology, but also of

- Handling technology
- Precision Mechanics

As a special service we offer our customers complete, ready-to-mount electromechanic solutions, especially developed and manufactured for special industries or individual customers. In many cases, this reduces the development overhead on the user side considerably. Thousands of systems installed prove Parker Hannifin's as well as their partner's - the "Parker Automation Technology Centers" - high competence and long experience.

Prefabricated integrated technology functions support the user's tasks. Furthermore, you can extend these functions by your own know-how at any time.

## Quality

Our customer systems must meet the highest demands with respect to resilience. Compax3 by Parker Hannifin exceeds by far the high quality requirements for an automation component. Not only the quality characteristics but also our customers speak volumes.

## Safety

With many applications in harsh and arduous environments such as presses and robot cells, Parker ensures that product and system reliability and quality are second to none. Drive integrated systems as implemented in Compax3 support the machine designer in realizing safe and cost-efficient solutions.

# Control Technology

## Real-time signal processing

- Reduction of the quantization noise
- Increase of the signal resolution
  - Due to oversampling of the speed and current signals
- Online feedback error compensation of offset and gain errors
- 14 Bit resolution increase - (Increase of the resolution of the scale graduation of up to 14 Bit)
  - By interpolation of sine-cosine feedback signals
- Determination of the speed by the observer technique
- Doubling of the controller bandwidth
  - By load torque observer principle

## Jerk-limited setpoint generation, resulting in:

- Gentle handling of the moved goods
- Increased service life of mechanical components
- Overshoot free positioning
- Reduced excitation for mechanical resonance frequencies

## Control:

- Controller in the feedback path helps avoid differentiating components in the numerator of the transmission function (which will result in a significant overshoot of the actual value)
- Automatic and robust controller design
  - User-oriented optimization parameters "damping" and "stiffness"
- Optimization of the response behavior
- Minimization of the following error
  - Due to feedforward of speed, acceleration, motor current and jerk
- Dual Loop Option
  - The load control can be activated via an additional feedback system for the acquisition of the actual position of the load.

## Commissioning/controller optimization

- Automatic determination of the load moment of inertia
- Compax3 MotorManager for determining the motor characteristics and the motor position feedback
- Optimization with integrated oscilloscope function

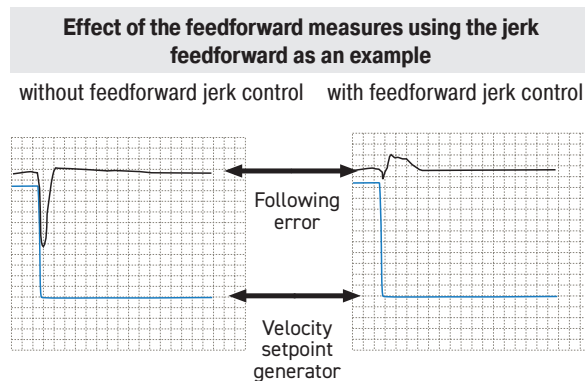
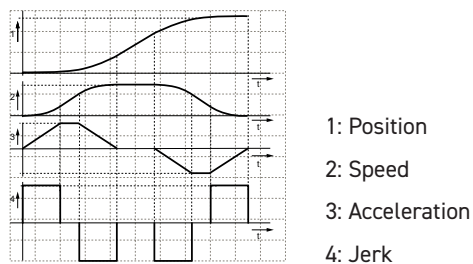
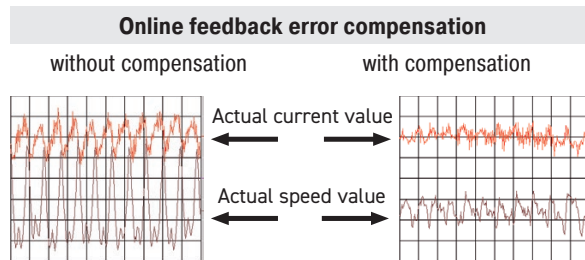
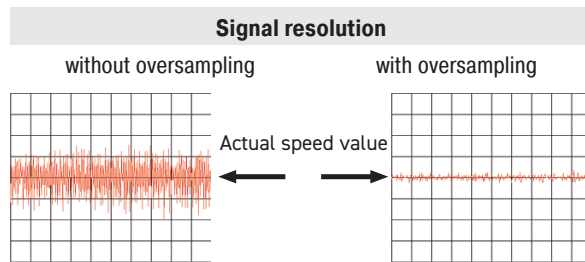

## Safety Technology

### Integrated Safety in the Compax3

In addition to the typical tasks of motion control, a modern drive controller must also be able to perform relevant safety tasks in order to comply with the requirements of the new machinery directive 2006/42/EG. Thanks to the integrated STO - "Safe Torque OFF" safety function, you will save space and money for external power relays. It also reduces error-prone external wiring. STO is today offered as a standard integrated into the Compax3 family servo drives.

## Device Technologies

### Compax3 I10T10: Step/Direction and Analog Command Input

#### I10T10 Scope of Functions

With its analogue interface or alternatively with step/direction or encoder step signals, the Compax3 I10T10 gives you easy and reasonably priced access to the world of servo-drive technology. Irrelevant of whether you have a PLC or PC central control unit, this remains unchanged.

The Compax3 I10T10 represents an ideal way of migrating from analog  $\pm 10$  V drives to digital, intelligent servo-drives.

**You can choose between the different operating modes:**

#### **$\pm 10$ V Input**

- $\pm 10$  V predefined speed with encoder simulation as actual value feedback
- $\pm 10$  V predefined current setpoint with encoder emulation for actual position value feedback and configurable holding functions
- Zero pulse of the emulation within a motor revolution can be freely selected

#### **Step/Direction Command Input**

- Step/direction signals as 24 V logic levels or
- With step/direction logic signals conforming to RS422

#### **Encoder Input**

- RS422
- 24 V level

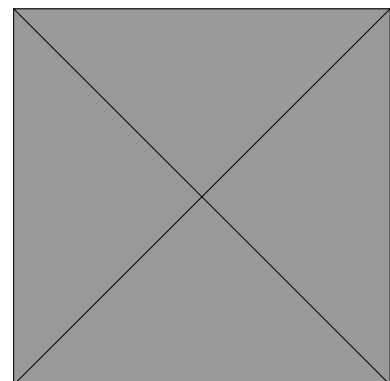
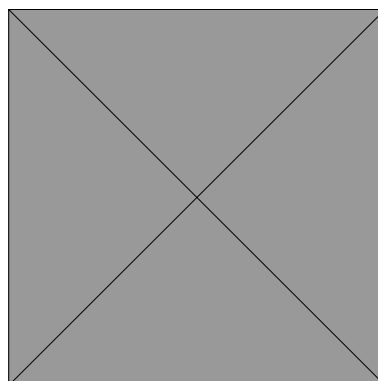
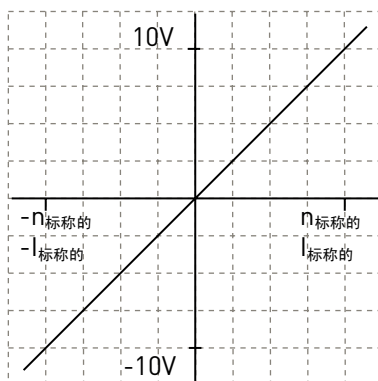

## Compax3 T11: Positioning T11 Scope of Functions

Due to its high functionality, the Positioning version of Compax3 forms an ideal basis for many applications in high-performance motion automation.

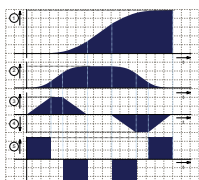

- Up to 31 motion profiles can be created with the help of the PC software:
  - Absolute or relative positioning
  - Electronic Gearbox (Gearing)
  - Reg-related positioning
  - Speed control
  - Stop - Set
- Dynamic positioning
- Movement profiles in non-volatile flash
- Motion profiles can be selected via field bus or digital inputs/outputs
- Wide choice of machine zero modes for your individual application
- Detection of the absolute position by distance-coded feedback
- Easy commissioning
  - Guided configuration with the Compax3 ServoManager
  - Flexible Optimization
- Adjustable jerk limitation
- Optional extension of the digital I/Os

## Compax3 I12T11 / Motion Control:

- Via digital I/Os
- Via RS232 / RS485 with the aid of control & status word
- Up to 31 motion functions via set table
- Status bits for each motion set

### Access via Compax3 inputs and outputs:

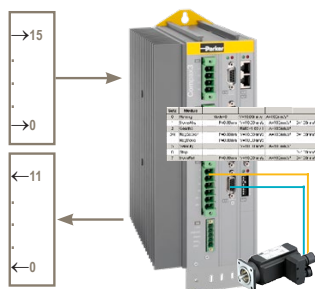

### Access via RS232 / RS485:

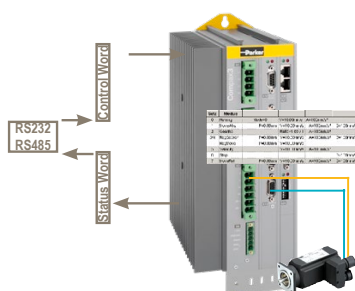

## Compax3 I2xT11 / I3xT11 Motion Control:

- Standard profiles via PROFIBUS, PROFINET, CANopen, DeviceNet, Ethernet Powerlink and EtherCAT
- Direct set specification via fieldbus telegrams or
- Set selection (31 motion sets)
- Status bits for each motion set
- Operating modes:
  - Speed controller, direct positioning, positioning via set selection

### Characteristics:

PROFIBUS	
Profile:	PROFIdrive Profile drive system V3
DP versions:	DPV0/DPV1
Baud rate:	up to 12 Mbit/s
PROFINET	
Profile:	PROFIdrive profile drive technology V4.1
Version:	PROFINET IO (RT)
Transmission mode:	100BASE-TX (Full Duplex)
CANopen	
Profile:	MotionControl CiADS402
Baud rate:	20...1000 Kbit/s
DeviceNet	
I/O Data:	up to 32 bytes
Baud rate:	125...500 Kbit/s
Nodes:	up to 63 slaves
Ethernet Powerlink	
Profile:	MotionControl CiADS402
Baud rate:	100 Mbit/s (FastEthernet)
Cycle time:	from 500 µs
EtherCAT	
Profile:	MotionControl CiADS402
Baud rate:	100 Mbit/s (FastEthernet)
Cycle time:	from 125 µs

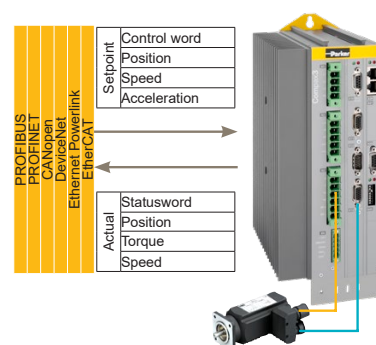

## Motion Function:

### Absolute / Relative Positioning:

MoveAbs and MoveRel

- A motion set defines a complete motion with all settable parameters.
  - (1) Target position
  - (2) Travel speed
  - (3) Maximum Acceleration
  - (4) Maximum deceleration
  - (5) Maximum Jerk

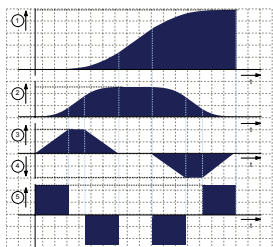

### Reg-related positioning:

RegSearch, RegMove

- For registration mark-related positioning, 2 motions are defined.
  - RegSearch: Search of an external signal - a reg; e.g. a mark on a product
  - RegMove: The external signal interrupts the search movement and the second movement by an offset follows without transition
- Accuracy of the reg detection: <math>< 1 \mu\text{s}</math>

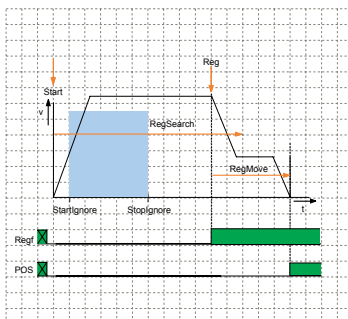

### Electronic Gearbox:

Gearing

- Synchronous motion to a leading axis with any transmission ratio. The position of a master axis can be detected via:
  - +/-10 V analog input
  - Step / direction input
  - the encoder input or
  - HEDA, with Compax3 master

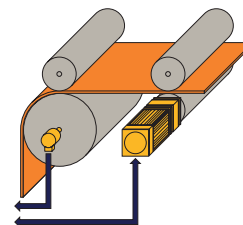

### Dynamic positioning

- You can switch to a new motion profile during a positioning sequence - a dynamic transition takes place.

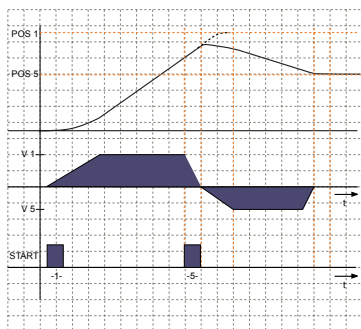

### speed control:

Velocity

- Defined via speed and acceleration.

### Stop movement:

Stop

- The Stop set interrupts the current motion set.

Satz	Motus	Move=0	V=10.00mm/s	A=100mm/s²	D=100mm/s²	J=1000000mm/s³	
0	Positioning		V=10.00mm/s	A=100mm/s²			000
1	MoveAbs	P=10.00mm	V=10.00mm/s	A=100mm/s²	D=100mm/s²	J=1000000mm/s³	11X
2	Velocity		V=30.00mm/s	A=100mm/s²			11X
3	Gearing		Ratio=0.25 / 1	A=100mm/s²			XXX
4	Stop				D=100mm/s²	J=1000000mm/s³	00X
5/6	RegSearch	P=50.00mm	V=10.00mm/s	A=100mm/s²	D=100mm/s²	J=1000000mm/s³	00X
	RegMove	P=60.00mm	V=10.00mm/s	A=100mm/s²	D=100mm/s²	J=1000000mm/s³	00X
7	MoveRel	P=-100.00mm	V=10.00mm/s	A=100mm/s²	D=100mm/s²	J=1000000mm/s³	11X
8	Gearing		Ratio=0.33 / 1	A=100mm/s²			XXX
9	MoveAbs	P=20.00mm	V=10.00mm/s	A=100mm/s²	D=100mm/s²	J=1000000mm/s³	00X
10	Stop				D=100mm/s²	J=1000000mm/s³	00X
11	MoveAbs	P=40.00mm	V=10.00mm/s	A=100mm/s²	D=100mm/s²	J=1000000mm/s³	11X
12/13	RegSearch	P=100.00mm	V=10.00mm/s	A=100mm/s²	D=100mm/s²	J=1000000mm/s³	000
	RegMove	P=0.00mm	V=10.00mm/s	A=100mm/s²	D=100mm/s²	J=1000000mm/s³	111
14	MoveRel	P=-40.00mm	V=10.00mm/s	A=100mm/s²	D=100mm/s²	J=1000000mm/s³	XXX
15	Stop				D=100mm/s²	J=1000000mm/s³	XXX
16	Velocity		V=25.00mm/s	A=100mm/s²			XXX
17	Gearing		Ratio=1.00 / 1	A=100mm/s²			XXX
18/19	RegSearch	P=70.00mm	V=10.00mm/s	A=100mm/s²	D=100mm/s²	J=1000000mm/s³	00X
	RegMove	P=0.00mm	V=10.00mm/s	A=100mm/s²	D=100mm/s²	J=1000000mm/s³	11X
20	MoveAbs	P=0.00mm	V=10.00mm/s	A=100mm/s²	D=100mm/s²	J=1000000mm/s³	XXX
21	Gearing		Ratio=0.13 / 1	A=100mm/s²			XXX
22	MoveAbs	P=0.00mm	V=10.00mm/s	A=100mm/s²	D=100mm/s²	J=1000000mm/s³	XXX
23	Stop				D=100mm/s²	J=1000000mm/s³	XXX
24	Velocity		V=10.00mm/s	A=100mm/s²			nnn

Entry of motion sets

## Compax3 T30: IIEC 61131-3 Positioning with function modules based on PLCopen T30 Scope of Functions

- Programming in accordance with IEC 61131-3
- Programming system: CoDeSys
- up to 6000 instructions
- 650 16bit variables / 200 32bit variables
- Recipe table with 288 variables
- 3 16-bit retain variables / 3 32-bit retain variables
- Inputs/outputs:
  - 8 digital inputs (24 V level)
  - 4 digital outputs (24 V level)
  - 2 analog inputs (14 Bit)
  - Optional extension of 12 inputs/ outputs
- IEC 61131-3 standard modules:
  - Up to 8 timers (TON, TOF, TP)
  - Triggers (R\_TRIG, F\_TRIG)
  - Flip-flops (RS, SR)
  - Counters (CTU, CTD, CTUD)
- Device-specific function modules:
  - C3\_Input: Generates an input process image
  - C3\_Output: Generates an output process image
  - C3\_ReadArray: Access to recipe table
  - Force control on request
- PLCopen function modules:
  - Positioning: absolute, relative, additive, continuous
  - Machine Zero
  - Stop, energizing the power stage, Quit
  - Position, device status, reading axis error
  - Electronic gearbox (MC\_GearIn)



### Compax3 Function Blocks

- Absolute Positioning
- Stop
- Reading axis error
- Relative Positioning
- Machine Zero
- Acknowledging errors
- Additive positioning
- Energizing the power stage
- Reading the current position
- Continuous positioning
- Reading device status
- Electronic Gearbox (Gearing)

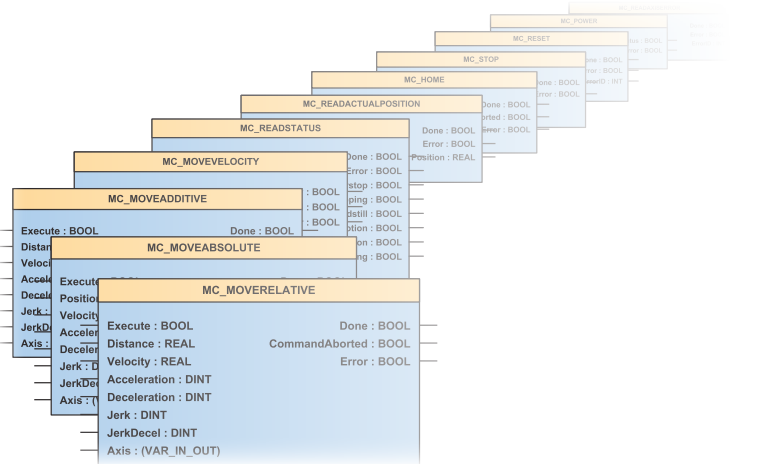

### Example of an IEC 61131 application controlled by means of a bus interface:

- 2 control words are placed on the cyclic channel of the bus.
- The position data records (position, speed, acceleration, ... are stored in a table (array).
- The desired position data record is selected with Controlword\_2.
- The individual bits of Controlword\_1 control positioning.
- A return message is given through a status word on the cyclic channel of the bus.

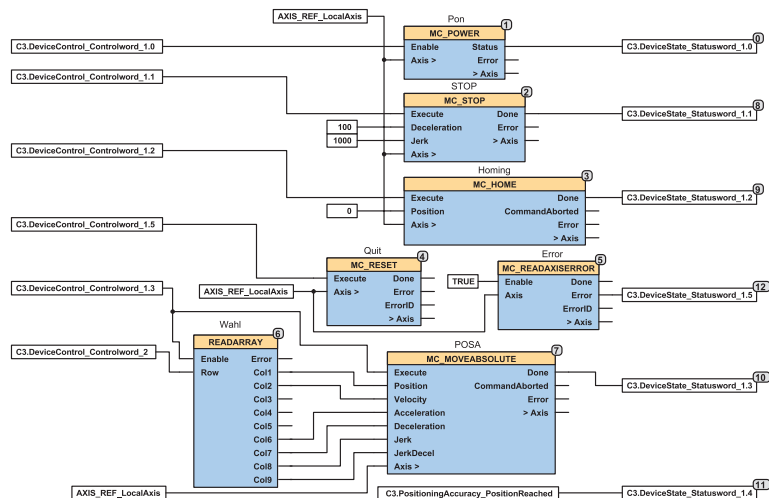

## Compax3 T40: IEC 61131-3 positioning with cam function modules

### T40 Scope of Functions:

Compax3 T40 is able to simulate mechanical cams and cam switching mechanisms electronically.

The "Electronic Cam - T40 was especially optimized for

- Packaging Machinery,
- Printing Industry as well as
- all applications where a mechanical cam is to be replaced by a flexible, cyclic electronic solution.

This helps to realize discontinuous material supply, flying knife and similar drive applications with distributed drive performance.

Compax3 T40 supports both real and virtual master movements. In addition, the user can switch to other cam profiles or cam segments on the fly.

Programming is carried out in the IEC 61131-3 environment.

Cam applications can be easily implemented with the aid of the cam function modules and the CamDesigner.

### T40 Function Overview:

- T30 Technology Functions completely integrated and available
- Master position acquisition
- Reg synchronization
- Electronic Cam switches
- Coupling and decoupling functions
- Cam profiles
- Cam memory
- Cam creation with the CamDesigner

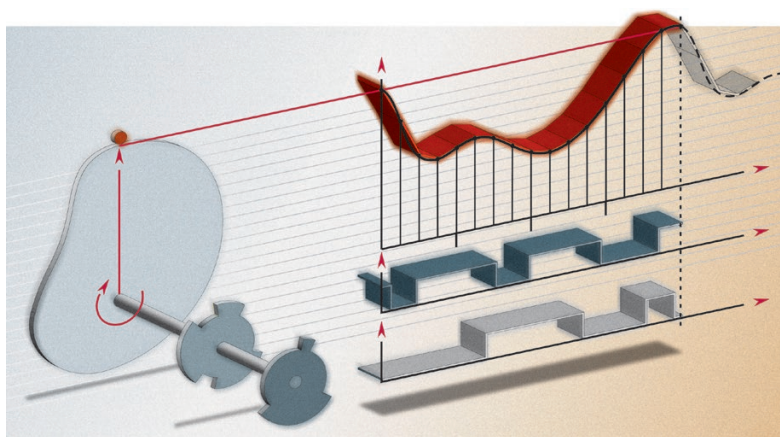

#### Cutting on the fly

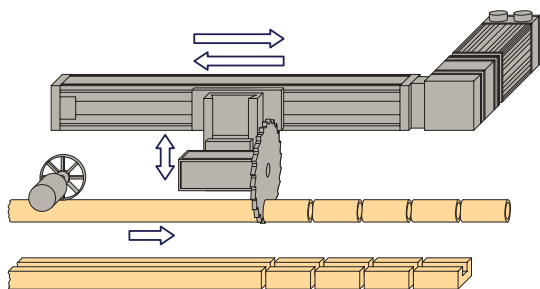

#### Diagonal-beam sawing

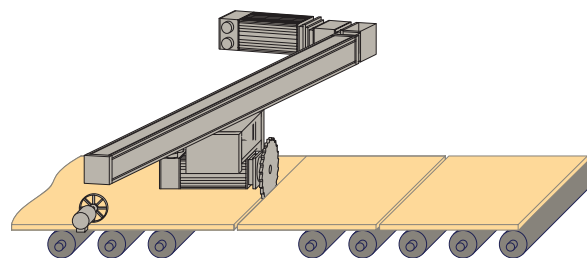

#### Machining during motion

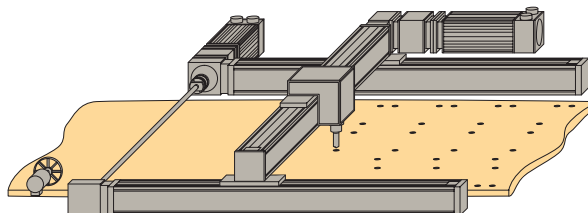

### Master Position Acquisition

- Acquisition via SSI encoder or incremental encoder
- Acquisition by the HEDA real-time bus
- Virtual master:
  - A second axis in the IEC - program can be used to program a motion profile which serves as a master for one or several slaves

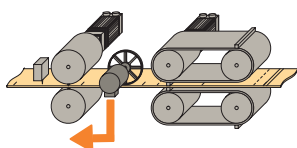

### Reg Synchronization

- Master or slave oriented (simultaneous, cam-independent)
- Highly precise reg mark recognition (accuracy < 1 μs; Touchprobe)

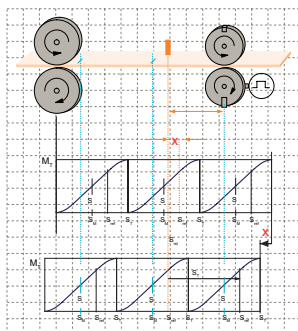

### Cam Memory

- 10 000 points (master / slave) in 24 bit format
- High-precision profile generation:
  - Non equidistant interpolation points of the master and slave coordinates (stored fail-safe)
  - Linear interpolation between interpolation points
- Cam memory for up to 20 curves

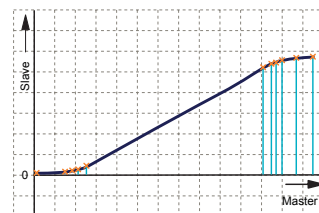

### Coupling and Decoupling Functions

- By means of a setpoint generator
- By means of a change-over function
- Without overspeeding by coupling over several master cycles
- Virtually free set-up of the coupling and decoupling movement
- Master-guided coupling movement
- Random standstill position

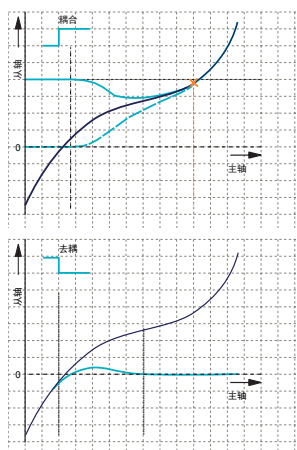

### Cam Profiles

- Up to 20 cam segments can be produced by:
  - Virtually random cam links (forwards and backwards)
  - Freely programmable event-controlled cam branches
  - Scalable cam segments and complete cam profiles

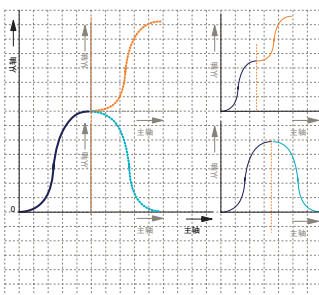

### Cam Controller

- 36 cams with individual profiles.
- 4 fast cams (125 μs per cam) standard: 500 μs.
- 32 serial cams, 16 ms/cam cycle (0.5 ms/cam).
- Delay-time compensated cams: Compax3 can advance the cam to compensate for delays in switching elements.

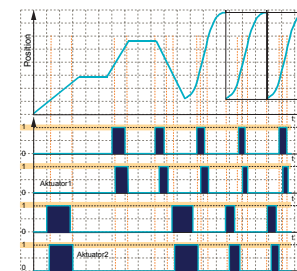

# TECHNICAL CHARACTERISTICS

## Technical Data

### Compax3S

Compax3	Unit	S025V2	S063V2	S100V2	S015V4	S038V4	S075V4	S150V4	S300V4 <sup>(1)</sup>
<b>Power supply and device currents</b>									
Power supply	[V]	1*230/240 VAC (80...253 VAC) / 50...60 Hz		3*230/240 VAC (80...253 VAC) / 50...60 Hz	3*400/480 VAC (80...528 VAC) / 50...60 Hz				
Output nominal current (rms)	[A]	2.5	6.3	10	1.5	3.8	7.5	15	30
Peak current (<5 s)	[A]	5.5	12.6	20.0	4.5	9.0	15.0	30.0	60.0
Power	[kVA]	1.0	2.5	4.0	1.25	3.1	6.2	11.5	25.0
Control voltage	[V]	24 VDC ±10 %, ripple <1 Vpp							
Electric current drain	[A]	0.8 A (Compax3) (+ digital outputs 0.1 A each + motor brake up to 1.6 A)							
<b>Dynamic Brake</b>									
Capacitance	[µF]	560	1120	780	235	235	470	690	1100
Storable energy	[Ws]	15 @230 V	30 @230 V	21@230 V	37@400 V 21@480 V	37@400 V 21@480 V	75@400 V 42@480 V	110@400 V 61@480 V	176@400 V 98@480 V

<sup>(1)</sup> Operation with capacitor module ModulC4.

### Compax3H

Compax3	Unit	H090V4	H125V4	H155V4
<b>Power supply and device currents</b>				
Power supply	[V]	3*400/480 VAC (350...528 VAC) / 50...60 Hz		
Output nominal current (rms)	[A]	90.0	125.0	155.0
Peak current (<5 s)	[A]	135.0	187.5	232.5
Power	[kVA]	70.0	91.0	109.0
Control voltage	[V]	24 VDC ±10 %, ripple <1 Vpp		
Electric current drain	[A]	0.8 A (Compax3) (+ digital outputs 0.1 A each + motor brake up to 1.6 A)		
<b>Dynamic Brake</b>				
Capacitance	[µF]	3150	5000	5000
Storable energy	[Ws]	729@400 V 507@480 V	1158@400 V 806@480 V	1158@400 V 806@480 V

## Safety Technology

### Compax3S

STO (Safe torque off) in accordance with EN ISO 13849:2008, category 3:PL=d/e. Certified: BG-PRÜFZERT

## Positioning

### Positioning on the motor shaft

- Resolver (option F10)
    - Resolution: 16 Bit (= 0.005°)
    - Absolute accuracy: +/-0.167°
  - SinCos® (Option F11)
    - Position resolution: 13.5Bit/Encoder sine period => 0.03107°/encoder resolution
  - Direct drives (F12)
    - Maximum position resolution:
      - Linear: 24 bits per motor magnet spacing
      - Rotary: 24 bits per motor revolution
    - For 1 Vpp sine-cosine encoders (e.g. EnDat): 13.5 bits / graduation of the encoder scale. For RS422 encoders: 4xEncoder resolution / Encoder Bypass possible. Accuracy of the feedback zero pulse acquisition = accuracy of the feedback resolution. For analog hall sensors with 1 Vpp signal: 13.5 bits / motor magnet spacing
- The exactitude of the position signal is above all determined by the type and exactitude of the feedback system used.

### Setpoint generator

- Jerk-limited ramps
- Travel data in increments, mm, inch or variable by scale factor
- Specification of speed, acceleration, deceleration and jerk

### Monitoring functions

- Power/auxiliary supply range
- Motor power stage temperature/stall protection
- Following error monitoring

## Supported Motor and Feedback Systems

### Motors

- Sinusoidally commutated synchronous motors
  - Maximum electrical turning frequency: 1000 Hz
  - Maximum velocity at 8 pole motors: 15 000 min<sup>-1</sup>
  - Maximum speed: 60\*1000/number of pole pairs in min<sup>-1</sup>
- Sinusoidal commutated asynchronous motors
  - Maximum electrical turning frequency: 1000 Hz
  - Maximum speed: 60\*1000/number of pole pairs - slip in min<sup>-1</sup>
- 3 phase synchronous direct drives

### Feedback systems

#### Option F10 for

- Resolver
  - Litton: JSSBH-15-E-5, JSSBH-21-P4, RE-21-1-A05, RE-15-1-B04
  - Tamagawa: 2018N321 E64
  - Siemens: 23401-T2509-C202
- Sine Cosine - Encoder with Hiperface® -
  - Rotary feedback with HIPERFACE® interface in Single or Multiturn version (absolute position up to 4096 motor revolutions):
  - For example: SRS/M50, SRS/M50S, SKS/M36, SEK52, SEL57, SEK37, SEL37, SEK 90/180/260

#### Option F12 for

- EnDat 2.1 or EnDat 2.2 feedback systems with/without incremental track (sine-cosine track)
  - Rotary feedback in Single or Multiturn version (absolute position up to 4096 motor revolutions):
  - Linear feedbacks
- Analog hall sensors
  - Sine - cosine signal (max. 5 VSS; typical 1 VSS) 90° offset
  - U-V Signal (max. 5 VSS; typical 1 VSS) 120° offset
- Linear or rotary encoders
  - U-V Signal (max. 5 VSS; typical 1 VSS) (max. 400 kHz) or
  - TTL (RS422) (max. 5 MHz) with the following modes of commutation: Automatic commutation or digital hall sensors
- Distance coded feedback systems
  - Distance coding with 1VSS interface
  - Distance coding with RS422 - Interface
  - Feedback error compensation: Automatic feedback error compensation

## Ambient Conditions

### Temperature range

#### Compax3S & Compax3H

0...45 °C

### Tolerated humidity

max. relative air humidity ≤85% class 3K3; non-condensing

### Elevation of operating site

- ≤1000 m asl for 100 % load ratings
- ≤2000 m above sea level for 1 % / 100 m power reduction
- please inquire for greater elevations

### Degree of protection

IP20 protection level in accordance with EN 60529

## Ports

### COM ports

- RS232, 115 200 Baud
- RS485, (2- or 4-wire) 9600, 19 200, 38 400, 57 600 or 115 200 Bauds

### Bus systems



- PROFIBUS DP V0-V2 (I20), 12 Mbit/s, PROFIdrive profile drive technology
- CANopen (CiADS402) (I21), 20...1000 Kbit/s, SDO1, PDO1, ... PDO4
- DeviceNet (I22), up to 32 bytes I/O, 125...500 Kbit/s, up to 63 slaves
- Ethernet Powerlink (I30), 100 Mbit/s (FastEthernet), from 500 µs (typ. 1 ms) cycle time
- EtherCAT (I31), 100 Mbit/s (FastEthernet), from 125 µs (typ. 1 ms) cycle time
- PROFINET (I32) certified, PROFINET IO (RT), 100BASE-TX (Full Duplex)

### Inputs and outputs

- 8 control inputs: 24 VDC / 10 kOhm
- 4 control outputs: Active HIGH / short-circuit proof/ 24 V / 100 mA
- 2 analog inputs (14 Bit)
- 2 analog outputs (8 Bit)

### Encoder simulation

- 4-16 384 increments per revolution (zero pulse can be feely selected within one motor revolution)
- Limit frequency: 620 kHz

## Standards and Conformance

### Insulation requirements

- Protection class in accordance with EN 60664-1
- Protection against human contact with dangerous voltages: in accordance with EN 61800-5-1
- Overvoltage: Voltage category III in accordance with EN 60664-1
- Level of contamination 2 in accordance with EN 60664-1 and EN 61800-5-1

### CE compliance

- 2006/42/EC Machinery Directive - Appendix IV
- 2014/30/EU EMC Directive

### UL certification

- UL conform according to UL508C
- Compax3S: Recognized Component Mark for Canada and the US

### RoHS Compliance

2011/65/EU RoHS Directive, supplemented by delegated directive (EU) 2015/863

# Dimensions

## Compax3S

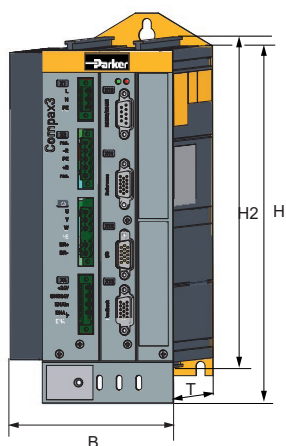

Device:	Dimensions [mm]				Weight [kg]
	H	B	T	H2	
<b>Compax3</b>					
S025V2	216	84	172	203	2.0
S063V2		100			2.5
S100V2	273	115		259	4.3
S150V4		158			6.8
S015V4		84			3.1
S038V4		100			3.5
S075V4		115			4.3
S300V4	380	175		391	10.9

## Compax3H

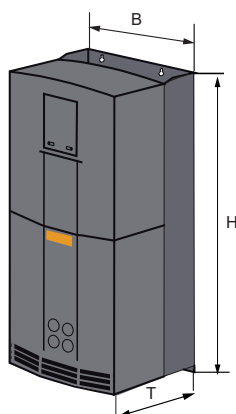

Device:	Dimensions [mm]			Weight [kg]
	H	B	T	
<b>Compax3</b>				
H090V4	669	257	312	32.5
H125V4	720	257	355	41.0
H155V4	720	257	355	41.0

### Enclosure

Insulation:  
VDE 0160 / Protection class IP20 in accordance with EN 60 529 (not for C3H1xxV4)

# ACCESSORIES AND OPTIONS

## Software and Tools

### C3 ServoManager

- Guided configuration
  - Automatic querying of all necessary entries
  - Graphical support
- Setup mode
  - Manual motion of individual axes
  - Predefined profiles
  - Convenient operation
  - Storage of defined profiles
  - Automatic determination of the moment of inertia
- integrated 4-channel oscilloscope
  - Signal tracking directly on the PC
  - Various modes (single/normal/auto/roll)
  - Zoom function
  - Export as image or table (for example to Excel)

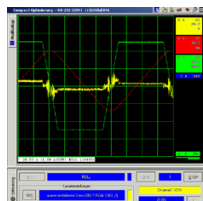

### MotorManager

- Complete library for Parker motors
  - Integration of customer motors
  - Determination of motor characteristics and of the motor position feedback

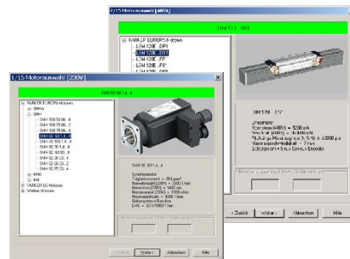

### CamDesigner

- Cam creation tool
- Standard and expert mode
  - Evaluation of the motion profiles
  - Verification of the drive selection
  - Transition laws from the VDI directive 2143

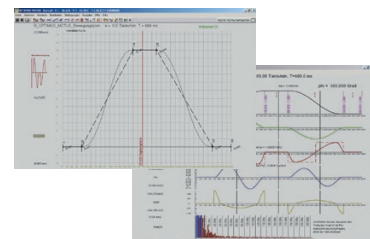

## Programming

### CoDeSys

CoDeSys is a development environment for programming that saves a significant amount of time as applications are created.

- Powerful developing environment, worldwide established
- Universal programming platform for various devices
- Complete offline simulation
- Visual elements
- Library management for user-defined applications
- Context-sensitive help wizard
- Data exchange between devices from different manufacturers
- Complete online functionality
- Sophisticated technological features
- Free of charge

### IEC61131-3

IEC 61131-3 is the only company- and product independent programming language with world-wide support for industrial automation devices.

- IEC 61131-3 includes graphical and textual programming languages:
- Instruction list
  - Structured text
  - Ladder diagram
  - Sequential function chart
  - Function block diagram
  - Integrated standards offer:
    - a trusted programming environment
    - standardized programming
  - Integrated standards reduce:
    - the overhead of development
    - maintenance costs
    - software upkeep
    - training overhead
  - Integrated standards increase:
    - productivity
    - software quality
    - concentration on core competence

### PLCopen

PLCopen is an organization that plays a significant role in supporting the IEC 61131-3 programming language. It is independent of individual companies or products. Its specific tasks also include defining basic processes relevant to motion. The PLCopen organization consists of both users and manufacturers of automation components. Parker Hannifin is an active member of the "Motion Control" task force. This represents a great advantage to users of Parker drive technology, since they are constantly able to profit directly from the latest developments in PLCopen.

**Parker is a member of the CoDeSys Automation Alliance"**



# Signal Analysis for the System Identification

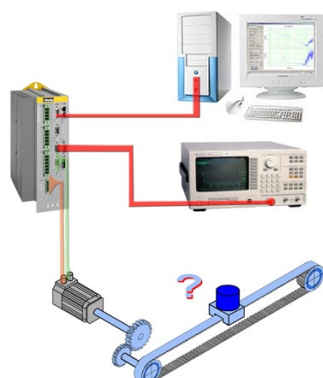

formerly

### Implementation prerequisites:

- Expensive and complex measurement technology required
- Special knowledge required
- Implementation only possible in an open control loop (=dangerous)

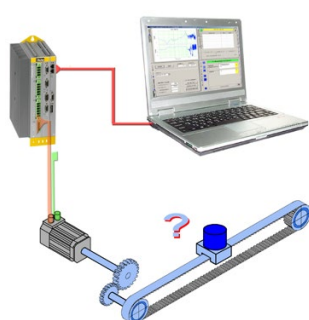

today

### Implementation prerequisites:

- Implementation with a common PC
- Simple and safe operation with the Compax3 ServoManager Software
- No special knowledge required
- The safety functions implemented in the servo drive ensure safe measurement in a closed position control loop

What do these functions provide?

### Analysis and optimization of the mechanic system

#### Transmission behavior of the mechanic system

- Simple measurement of the mechanic dynamic behavior, therefore:
- Possibilities to improve the mechanic construction can be spotted.
- Increased stiffness and precision of the entire system.  
(improved mechanic system = improved controller performance)

#### Modal analysis

- Vibration analysis of the mechanic construction by specification of a sinusoidal motor force with a defined frequency.
- It is often possible to work without additional excitation by electrodynamic shakers or pulse hammers.

### Analysis and optimization of the control

#### Transmission behavior of the mechanic system

- Better and faster controller optimization due to the knowledge of the transmission behavior of the control path.
- Specific suppression of disturbances at the mechanic resonance points with the aid of notch or low-pass filters.

#### Transmission behavior of the control

- Quality assessment of the control with respect to the response behavior:
  - In the time range by step response
  - In the frequency range by frequency response
- Optimization of the control by application of stability criteria from the control theory (e.g. Nyquist criterion or Hurwitz criterion)
- Quality assessment of the control with respect to the disturbance behavior:
  - In the time range by the disturbance current - step response<sup>1</sup>
  - In the frequency range by measurement and analysis of the resilience - frequency response<sup>2</sup>

<sup>1</sup> Emulation of an external volatile change in the disturbance force.

<sup>2</sup> The compliance frequency response states the size of the control deviation caused by a disturbance force in dependence of its frequency.

# ORDER CODE

## Devices: Compax3

	1	2	3	4	5	6	7	
Example:	<b>C3</b>	<b>S</b>	<b>025</b>	<b>V2</b>	<b>F10</b>	<b>I10</b>	<b>T10</b>	<b>M00</b>

### 1 Device family

**C3** Compax3

### 2 Device type

**S** Single-axis

**H** High power

### 3 Device currents static/dynamic; supply voltage

#### Compax3S

**025 V2** 2.5 A / 5 A; 230 VAC (single phase)

**063 V2** 6.3 A / 12.6 A; 230 VAC (single phase)

**100 V2** 10 A / 20A; 230 VAC (3 phase)

**015 V4** 1.5 A / 4.5 A; 400 VAC (3 phase)

**038 V4** 3.8 A / 9 A; 400 VAC (3 phase)

**075 V4** 7.5 A / 15.0 A; 400 VAC (3 phase)

**150 V4** 15.0 A / 30.0 A; 400 VAC (3 phase)

**300 V4** 30.0 A / 60.0 A; 400 VAC (3 phase) <sup>(1)</sup>

#### Compax3H

**090 V4** 90 A / 135 A; 400 VAC (3 phase)

**125 V4** 125 A / 187.5 A; 400 VAC (3 phase) <sup>(2)</sup>

**155 V4** 155 A / 232.5 A; 400 VAC (3 phase) <sup>(2)</sup>

### 4 Feedback

**F10** Resolver, SinCos® (Hiperface)

**F12** Encoder, Sine/cosine with/without hall, EnDat

### 5 Interface

**I10** Step/direction / analog input (only I10T10)

**I11** Positioning via inputs/outputs (only I11T11)

**I12** Positioning via I/Os or RS232 / RS485 / USB

**I20** PROFIBUS DP V0/V1/V2 (12 Mbaud)

**I21** CANopen

**I22** DeviceNet

**I30** Ethernet Powerlink

**I31** EtherCAT

**I32** PROFINET

### 6 Technology function

**T10** Servo controller (only I10)

**T11** Positioning

**T30** Motion control programmable in accordance with IEC 61131-3

**T40** Motion control programmable in accordance with IEC 61131-3 & electronic cam

### 7 Options

**M00** No additional supplement

**M10** Extension by 12 digital I/Os & HEDA Motionbus (not for T10, T11)

**M11** HEDA Motionbus (not for T10, T11)

**M12** Extension by 12 digital I/Os (not for T10, T11)

**M21** Analog current / voltage inputs (0...20 mA) and (-10...+10 V) (3 each)

<sup>(1)</sup> Operation of the C3S300V4 with capacitor module ModulC4.

<sup>(2)</sup> external voltage supply for ventilator fan required. Available in two versions for single phase feed. Standard: 220/240 VAC: 140 W, on request: 110/120 VAC: 130 W

PROFIBUS and PROFINET are registered trademarks of PROFIBUS & PROFINET International (PI). EtherCAT® is a registered trademark and patented technology, licensed by Beckhoff Automation GmbH, Germany.

## Cables

	1	2	3	4		5		6		7		8
Example:	<b>CBM</b>	<b>015</b>	<b>H</b>	<b>B</b>	-	<b>C01</b>	-	<b>D01</b>	-	<b>0050</b>	-	<b>00</b>

### Type

CBM	Motor cable
CBF	Feedback cable

### Cross section motor cable / Feedback type

007	0.75 mm <sup>2</sup>
015	1.5 mm <sup>2</sup>
025	2.5 mm <sup>2</sup>
040	4.0 mm <sup>2</sup>
060	6.0 mm <sup>2</sup>
RE0	Resolver

### Raw cable

S	Standard
H	Highflex
T	High Temperature (for ATEX Motors)

### Equipment Type

0	Standard
B	With brake
D	With brake & DSL

### Type of motor connector

C01	SMH Motor Power – M15
C02	SMH or MH– M23
C04	NX Motor Power – M23
C06	SMH or MH Motor Resolver – M23
C07	NX2-8 – Resolver Connector – M23
C11	M15 Hiperface DSL Feedback + Power
C12	M23 Hiperface DSL Feedback + Power –SMH, NX
C13	M40 Hiperface DSL Feedback + Power – MH
C14	SMH Motor Resolver – M15
T02	SMx82-100-115 & MB105-205 Motor Power – Terminal Box
T03	EX/EY Motor Power with Hiperface DSL – Terminal Box
T04	EX Motor Power – Terminal Box

### Type of drive connector

D01	PSD1S, PSD1MW18, C3 motor cable
D02	PSD1MW1-3 (w/o PSD1MW18) motor cable
D03	PSD1S or PSD1M – Resolver Feedback
D05	C3 (Compax3) – Resolver Feedback

### Length

0030	3 m
0050	5 m
0070	7 m
0100	10 m
0150	15 m
0200	20 m
...	...

### Customization/Special

00	Standard
----	----------

## Connection set for Compax3 and PSUP

Mating plug connector (furnished with the device)

	1
Example:	<b>ZBH02/02</b>

### 1 Accessories

<b>ZBH02/01</b>	for C3S0xxV2
<b>ZBH02/02</b>	for C3S0xxV4 / S150V4 / S1xxV2
<b>ZBH02/03</b>	for C3S300V4

## Other Feedback cable

	1
Example:	<b>GBK24/02</b>

### 1 Accessories

	<b>for MH/SMH motors</b>
<b>GBK24/....<sup>(1)</sup></b>	SinCos© feedback cable <sup>(2)</sup> cable chain compatible
<b>GBK38/....<sup>(1)</sup></b>	EnDat 2.1 feedback cable <sup>(2)</sup> cable chain compatible (C3S, H, M)

<sup>(1)</sup> - <sup>(4)</sup> see "Length code for cables" (page 26)



## Order code for interface cables and connectors

Example:	1 <b>SSK01/01</b>
----------	----------------------

1 Accessories	
<b>SSK01/....</b> <sup>(1)</sup>	RS232 (PC-Compax3)
<b>SSK21/....</b> <sup>(1)</sup>	Ref / analog - with flying leads (X11, X13 @C3F001D2)
<b>SSK22/....</b> <sup>(1)</sup>	Digital I/Os with flying leads (X12 / X22)
<b>SSK23/....</b> <sup>(1)</sup>	Ref /analog for I/O terminal block (X11)
<b>SSK24/....</b> <sup>(1)</sup>	Digital I/Os for I/O terminal block (X12, X22)
<b>SSK28/....</b> <sup>(5)</sup>	RJ45 Crossover cable (C3 HEDA-HEDA, PC-C3 powerPLmC, C3M-C3M communication, PROFINET, EtherCAT, Ethernet Powerlink)
<b>SSK29/....</b> <sup>(1)</sup>	Encoder coupling of 2 axes (X11-X11)
<b>SSK32/20</b>	Adapter cable for C3H to SSK01 (15 cm furnished with the device)
<b>VBK17/01</b>	RS232 connection controller-programming interface (furnished with the device for C3H X10)
<b>BUS07/01</b>	Bus terminal connector (1st. and last C3 in the HEDA bus/or multi-axis system)
<b>SSL01</b> <sup>(7)</sup>	PROFIBUS cable <sup>(2)</sup> not prefabricated
<b>BUS08/01</b>	Profibus connector Plug with 2 cable inputs (1 arriving, 1 continuing PROFIBUS cable), as well as a switch for activating the terminal resistor
<b>SSL02</b> <sup>(7)</sup>	CAN Bus cable <sup>(2)</sup> not prefabricated
<b>BUS10/01</b>	CAN bus connector Plug with 2 cable inputs (1x arriving, 1x continuing CANbus cable), as well as a switch for activating the terminal resistor

<sup>(1)-(6)</sup> see "Length code for cables" (page 26)

**DeviceNet** -A mating plug is included in the delivery. Additional information on DeviceNet wiring can be found under: [www.odva.org](http://www.odva.org)

## Length code for cables

<sup>(1)</sup> Length code 1 (Example: SSK01/09 = length 25 m)

Length [m]	1.0	2.5	5.0	7.5	10.0	12.5	15.0	20.0	25.0	30.0	35.0	40.0	45.0	50.0
Order code	01	02	03	04	05	06	07	08	09	10	11	12	13	14

<sup>(2)</sup> Color according to DESINA

<sup>(3)</sup> with motor connector

<sup>(4)</sup> with cable eye for motor terminal box



<sup>(5)</sup> length code 2 for SSK28

Length [m]	0.17	0.25	0.5	1.0	3.0	5.0	10.0
Order code	23	20	21	01	22	03	05

<sup>(6)</sup> Order code: SSK27/nn/..

Length A (Pop - 1st. Compax3) variable (the last two numbers corresponding to the cable length code for example SSK27/nn/01).

Length B (1st. Compax3 - 2nd. Compax3 - ... nth. Compax3) fixed 50 cm (only if there is more than 1 Compax3, i.e. nn greater than 01).

Number n (the last two digits)

<sup>(7)</sup> Number ordered corresponds to the cable length in m

<sup>(8)</sup> xxxx = length in dm (Example: 0030 = 3m)

## Braking resistors

	1	2
Example:	<b>BRM</b>	<b>05/01</b>

<b>1 Accessories</b>		
<b>BRM</b>	Braking resistor	
<b>2 Type</b>		
<b>05/01</b>	56 Ω / 0.18 kW <sub>cont.</sub> (for C3S063V2, C3S075V4)	
<b>05/02</b>	56 Ω / 0.57 kW <sub>cont.</sub> (for C3S075V4)	
<b>08/01</b>	100 Ω / 60 W <sub>cont.</sub> (for C3S025V2, C3S038V4)	
<b>10/01</b>	47 Ω / 0.57 kW <sub>cont.</sub> (for C3S150V4)	
<b>04/01</b>	15 Ω / 0.57 kW <sub>cont.</sub> (for C3S300V4)	
<b>04/02</b>	15 Ω / 0.74 kW <sub>cont.</sub> (for C3S300V4)	
<b>04/03</b>	15 Ω / 1.5 kW <sub>cont.</sub> (for C3S300V4)	
<b>09/01</b>	22 Ω / 0.45 kW <sub>cont.</sub> (for C3S100V2)	
<b>11/01</b>	27 Ω / 3.5 kW <sub>cont.</sub> (for C3H0xxV4)	
<b>12/01</b>	18 Ω / 4.5 kW <sub>cont.</sub> (for C3H1xxV4)	

## Mains filter

For radio interference suppression and compliance with the emission limit values for CE conform operation.

	1	2
Example:	<b>NFI</b>	<b>01/01</b>

<b>1 Accessories</b>		
<b>NFI</b>	Mains filter	
<b>2 Type</b>		
<b>01/01</b>	for C3S025V2 or S063V2	
<b>01/02</b>	for C3S0xxV4, S150V4 or S1xxV2	
<b>01/03</b>	for C3S300V4	

## Motor output choke

For disturbance suppression when the motor connecting cables are long

	1	2
Example:	<b>MDR</b>	<b>01/04</b>

<b>1 Accessories</b>		
<b>MDR</b>	Motor output choke (for Compax3S, Compax3M >20 m motor cable)	
<b>2 Type</b>		
<b>01/01</b>	up to 16 A rated motor current	
<b>01/02</b>	up to 30 A rated motor current	
<b>01/04</b>	up to 6.3 A rated motor current	

## Capacitor module

	1
Example:	<b>ModulC4</b>

<b>1 Accessories</b>	
<b>ModulC4</b>	1100 μF for C3S300V4 optional for C3H

### Inputs/Outputs:

#### Terminal block: EAM06/..

For additional wiring of the inputs/outputs:

- Can be mounted in the control cabinet via top hat rail
- Connection EAM06/.. via SSK23/.. to X11, SSK24/.. to X12



## Terminal block

	1	2
Example:	<b>EAM</b>	<b>06/01</b>

<b>1 Accessories</b>		
<b>EAM</b>	Terminal block	
<b>2 Type</b>		
<b>06/01</b>	I/Os without luminous indicator (for X11, X12, X22)	
<b>06/02</b>	I/Os with luminous indicator (for X12, X22)	





Parker Hannifin Corporation  
**Motion Systems Group Europe**  
Parker Hannifin EMEA Sàrl European Headquarters  
La Tuilière 6 Etoy  
Switzerland CH-1163  
[www.parker.com](http://www.parker.com)

192-120013 02/2025  
Your Local Authorized Parker Distributor

© 2025 Parker Hannifin Corporation

