



# SERIE MH / MB SERVO MOTORS

Servo Motors from 4.5 to 285 Nm



**WARNING – USER RESPONSIBILITY****FAILURE OR IMPROPER SELECTION OR IMPROPER USE OF THE PRODUCTS DESCRIBED HEREIN OR RELATED ITEMS CAN CAUSE DEATH, PERSONAL INJURY AND PROPERTY DAMAGE.**

- This document and other information from Parker-Hannifin Corporation, its subsidiaries and authorized distributors provide product or system options for further investigation by users having technical expertise.
- The user, through its own analysis and testing, is solely responsible for making the final selection of the system and components and assuring that all performance, endurance, maintenance, safety and warning requirements of the application are met. The user must analyze all aspects of the application, follow applicable industry standards, and follow the information concerning the product in the current product catalog and in any other materials provided from Parker or its subsidiaries or authorized distributors.
- To the extent that Parker or its subsidiaries or authorized distributors provide component or system options based upon data or specifications provided by the user, the user is responsible for determining that such data and specifications are suitable and sufficient for all applications and reasonably foreseeable uses of the components or systems.

**Offer of Sale**

Please contact your Parker representation for a detailed "Offer of Sale".

## Table of Contents

Overview .....	4
Technical Characteristics .....	5
MH / MB Motors, Size 145 - 4.5...28 Nm .....	5
MH / MB Motors, Size 205 - 15...90 Nm .....	7
MH / MB Motors, Size 265 - 75...285 Nm .....	9
MH / MB Motors, Fan cooled versions Size 265 - 145...580 Nm ..	9
Dimensions .....	10
Options .....	11
Order Code .....	15



If you have questions about the products contained in this catalogue, or their applications, please contact:  
**Parker Hannifin EMEA Sàrl European Headquarters**  
[parker.com/msgc](http://parker.com/msgc)

# OVERVIEW

## Servo Motor - MH / MB

### Description

The MH / MB series caters for torques in the range of 4.5 to 285 Nm, speeds up to 4500 min<sup>-1</sup> and includes a total of 50 models available across 3 frame sizes. Thanks to the high quality and performance of the Neodymium-Iron-Boron magnets, and also the encapsulation method used to fasten them to the shaft, the MH / MB series of motors can achieve very high accelerations and withstand high overload without the risk of demagnetisation or detachment of the magnets.

Furthermore, shaft and flange size flexibility on all models provides the user with the possibility to optimise their motor selection for any given application.

Adequate mechanical over-sizing, low inertia in an extra-strong mechanism and a broad range of models permits the application of the MH / MB series in all fields where high dynamic performance and utmost reliability are crucial features.

Typical applications include any type of automatic machinery, especially in the product packaging and handling industry, and wherever the demand exists for axis speed and position synchronisation.

### Features

- Large set of feedback option
- Customization
- Increase inertia option
- Options
  - Terminal box (power and resolver)
  - Increased inertia
  - Brake
  - Feedback - resolver/incremental/ SinCos/absolute encoder
  - Thermal protection (PTC for MB and KTY compatible for MH)

### Application

- Food, Pharma & Beverage
- Packaging Machines
- Material Forming
- Material Handling
- Factory Automation
- Life Science Diagnostic
- Automotive Industry / In-Plant
- Printing Industry
- Textile Machines
- Robotics
- Servo Hydraulic Pumps



### Technical Characteristics - Overview

Motor Type	Permanent magnets synchronous servo motor
Rotor Design	Rotor with surface rare earth magnets
Power supply	230 VAC or 400 VAC
Operating temperature	-10/+40 °C
Number of poles	8 for M_ 145-205-265
Power Range	0.25...67 kW
Torque Range	4.5...285 Nm
Speed Range	0...4500 min <sup>-1</sup>
Mounting	Flange with smooth holes B14
Shaft End	Plain keyed shaft Plain smooth shaft (option)
Cooling	Natural ventilation Self-ventilation (option for size 145-205) Forced ventilation (option for size 145-205-265) Water cooled (option for size 145)
Protection Level (IEC60034-5)	IP64 IP65 (option)
Feedback sensor	Resolver Absolute EnDat or Hiperface Incremental Encoder
Voltage Supply	230 / 400 VAC
Temperature Class	Class F
Connections	Connectors Terminal Box (see table option for combination)
Marking	CE
Standards In compliance with:	2014/35/UE 2011/65/UE 2015/863/EU 2009/125/EC IEC/EN 60034-1 IEC 60034-5 IEC/EN 60204-1

# TECHNICAL CHARACTERISTICS

## MH / MB Motors, Size 145 - 4.5...28 Nm

### 230 VAC

Model	Size	Stall		Nominal			Peak Torque <sup>(1)</sup>	Inertia		Ke <sup>(2)(3)</sup>	Kt <sup>(2)(3)</sup>
		Torque <sup>(1)</sup>	Current	Torque <sup>(1)</sup>	Speed	Current		No brake	With brake		
		T <sub>065</sub> (T <sub>105</sub> ) [Nm]	I <sub>065</sub> [A]	T <sub>n065</sub> [Nm]	n [min <sup>-1</sup> ]	I <sub>n065</sub> [A]	T <sub>max</sub> [Nm]	J [kgmm <sup>2</sup> ]	J [kgmm <sup>2</sup> ]	Ke [Vs]	Kt [Nm/A <sub>rms</sub> ]
M_145 5,5 04	145	4.5 (9)	1.1	4.6	550	1.1	28	780	975	2.1	3.65
M_145 11 04			2.3	4.6	1100	2.4				1.2	2.03
M_145 16 04			3.4	4.5	1600	3.3				0.8	1.42
M_145 25 04			4.7	4.3	2500	4.5				0.6	1.01
M_145 40 04			8.1	4.1	4000	7.2				0.4	0.60
M_145 5,5 08		8.7 (16)	2.0	8.7	550	2.0	49	1050	1245	2.7	4.69
M_145 11 08			3.7	8.7	1100	3.6				1.4	2.49
M_145 16 08			5.4	8.6	1600	5.2				1.0	1.70
M_145 25 08			8.2	8.1	2500	7.4				0.7	1.14
M_145 40 08			12.3	7.0	4000	9.7				0.4	0.76
M_145 5,5 15		15.0 (27)	3.3	15.0	550	3.2	86	1600	1795	2.9	4.94
M_145 11 15			6.2	14.7	1100	5.9				1.5	2.59
M_145 16 15			9.1	14.3	1600	8.5				1.0	1.78
M_145 25 15			14.2	13.6	2500	12.5				0.7	1.14
M_145 40 15			21.3	10.9	4000	15.0				0.4	0.76
M_145 5,5 22		22.0 (37)	4.7	21.9	550	4.6	117	2150	2345	2.9	5.03
M_145 11 22			8.9	21.3	1100	8.4				1.5	2.65
M_145 16 22			13.1	20.8	1600	12.1				1.0	1.80
M_145 25 22			20.8	19.1	2500	17.6				0.7	1.13
M_145 40 22			31.1	13.4	4000	18.6				0.4	0.76
M_145 5,5 28	28.0 (45)	5.9	27.8	550	5.8	143	2700	2895	2.9	5.07	
M_145 11 28		11.3	26.9	1100	10.6				1.5	2.65	
M_145 16 28		17.0	26.2	1600	15.5				1.0	1.78	
M_145 25 28		26.5	23.2	2500	21.4				0.7	1.13	
M_145 40 28		39.6	14.1	4000	19.7				0.4	0.76	

### 400 VAC

Model	Size	Stall		Nominal			Peak Torque <sup>(1)</sup>	Inertia		Ke <sup>(2)(3)</sup>	Kt <sup>(2)(3)</sup>
		Torque <sup>(1)</sup>	Current	Torque <sup>(1)</sup>	Speed	Current		No brake	With brake		
		T <sub>065</sub> (T <sub>105</sub> ) [Nm]	I <sub>065</sub> [A]	T <sub>n065</sub> [Nm]	n [min <sup>-1</sup> ]	I <sub>n065</sub> [A]	T <sub>max</sub> [Nm]	J [kgmm <sup>2</sup> ]	J [kgmm <sup>2</sup> ]	Ke [Vs]	Kt [Nm/A <sub>rms</sub> ]
M_145 10 04	145	4.5 (9)	1.1	4.5	1000	1.1	28	780	975	2.1	3.65
M_145 20 04			2.3	4.5	2000	2.3				1.2	2.03
M_145 30 04			3.4	4.3	3000	3.2				0.8	1.42
M_145 45 04			4.7	3.9	4500	4.0				0.6	1.01
M_145 10 08			8.7 (16)	2.0	8.7	1000				1.9	49
M_145 20 08		3.7		8.4	2000	3.5	1.4	2.49			
M_145 30 08		5.4		7.9	3000	4.8	1.0	1.70			
M_145 45 08		8.2		7.1	4500	6.6	0.7	1.14			
M_145 10 15		15.0 (27)		3.3	14.8	1000	3.1	86	1600	1795	
M_145 20 15			6.2	13.7	2000	5.5	1.5				2.59
M_145 30 15			9.1	12.7	3000	7.5	1.0				1.78
M_145 45 15			14.2	9.8	4500	9.1	0.7				1.14
M_145 10 22			22.0 (37)	4.7	21.4	1000	4.5				117
M_145 20 22		8.9		19.4	2000	7.6	1.5	2.65			
M_145 30 22		13.1		17.3	3000	10.1	1.0	1.80			
M_145 45 22		20.8		11.6	4500	10.8	0.7	1.13			
M_145 10 28		28.0 (45)		5.9	27.1	1000	5.6	143	2700	2895	
M_145 20 28			11.3	23.9	2000	9.4	1.5				2.65
M_145 30 28			17.0	21.1	3000	12.5	1.0				1.78
M_145 45 28			26.5	10.0	4500	9.4	0.7				1.13

# TECHNICAL CHARACTERISTICS

## MH / MB Motors, Size 145 - 4.5...28 Nm

### Speed Torque Curves

MH/MB145

2500 min<sup>-1</sup> 230 V - 4500 min<sup>-1</sup> 400 V

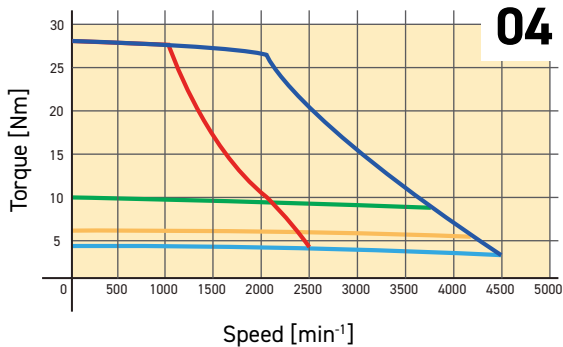

2500 min<sup>-1</sup> 230 V - 4500 min<sup>-1</sup> 400 V

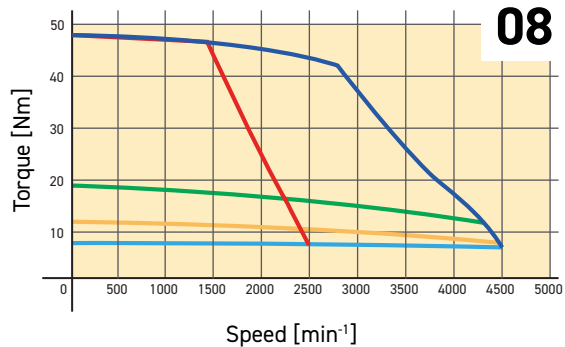

2500 min<sup>-1</sup> 230 V - 4500 min<sup>-1</sup> 400 V

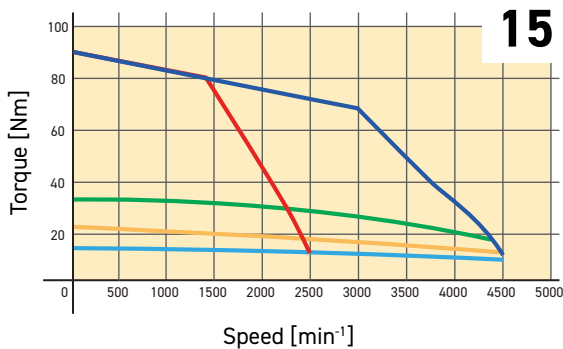

2500 min<sup>-1</sup> 230 V - 4500 min<sup>-1</sup> 400 V

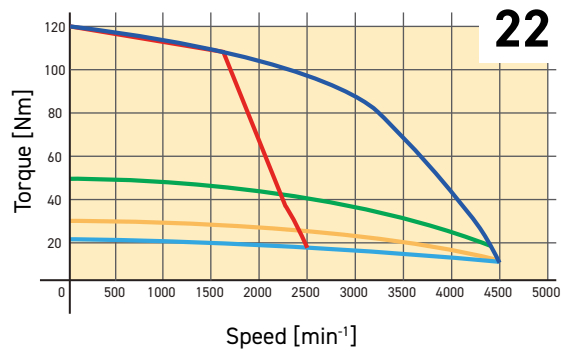

2500 min<sup>-1</sup> 230 V - 4500 min<sup>-1</sup> 400 V

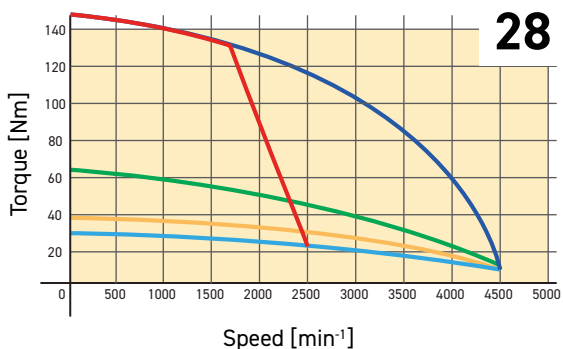

- S1 65 K, ΔT
- S3 10 %, 5 min, 400 V
- S3 10 %, 5 min, 230 V
- S3 50 %, 5 min
- S3 20 %, 5 min

- (1) Data referred to motor suspend in horizontal position in free still air, 20 °C ambient temperature
- (2) Data measured at 20 °C. When "hot" consider 5 % derating
- (3) Tolerance data ±10 %

# TECHNICAL CHARACTERISTICS

## MH / MB Motors, Size 205 - 15...90 Nm

### 230 VAC

Model	Size	Stall		Nominal			Peak Torque <sup>(1)</sup>	Inertia		Ke <sup>(2)(3)</sup>	Kt <sup>(2)(3)</sup>
		Torque <sup>(1)</sup>	Current	Torque <sup>(1)</sup>	Speed	Current		No brake	With brake		
		T <sub>065</sub> (T <sub>105</sub> ) [Nm]	I <sub>065</sub> [A]	T <sub>n065</sub> [Nm]	n [min <sup>-1</sup> ]	I <sub>n065</sub> [A]	T <sub>max</sub> [Nm]	J [kgmm <sup>2</sup> ]	J [kgmm <sup>2</sup> ]	Ke [Vs]	Kt [Nm/A <sub>rms</sub> ]
M_205 11 15	205	15 (22)	6.3	14.7	1150	6.2	69	3500	4035	1.4	2.38
M_205 17 15			8.6	14.4	1700	8.3				1	1.74
M_205 5,5 28		28 (39)	6.9	28.6	550	6.9	123	5000	5535	2.5	4.35
M_205 11 28			13.0	28.2	1150	12.7				1.3	2.31
M_205 17 28			20.1	27.6	1700	19.3				0.9	1.50
M_205 5,5 50		50 (70)	12.4	51.3	550	12.3	222	8000	8535	2.5	4.35
M_205 11 50			22.1	50.0	1150	21.3				1.4	2.45
M_205 17 50			33.1	48.0	1700	30.8				0.9	1.63
M_205 5,5 70		70 (98)	16.8	71.1	550	16.5	310	11 000	11 535	2.6	4.49
M_205 11 70			30.7	68.6	1150	29.3				1.4	2.45
M_205 17 70			46.1	65.0	1700	41.7				0.9	1.63
M_205 5,5 90		90 (126)	22.1	90.9	550	21.8	398	14 000	14 535	2.5	4.35
M_205 11 90			44.3	87.0	1150	41.8				1.3	2.18
M_205 17 90			59	81.7	1700	52.4				0.9	1.63

### 400 VAC

Model	Size	Stall		Nominal			Peak Torque <sup>(1)</sup>	Inertia		Ke <sup>(2)(3)</sup>	Kt <sup>(2)(3)</sup>
		Torque <sup>(1)</sup>	Current	Torque <sup>(1)</sup>	Speed	Current		No brake	With brake		
		T <sub>065</sub> (T <sub>105</sub> ) [Nm]	I <sub>065</sub> [A]	T <sub>n065</sub> [Nm]	n [min <sup>-1</sup> ]	I <sub>n065</sub> [A]	T <sub>max</sub> [Nm]	J [kgmm <sup>2</sup> ]	J [kgmm <sup>2</sup> ]	Ke [Vs]	Kt [Nm/A <sub>rms</sub> ]
M_205 20 15	205	15 (22)	6.3	14.1	2000	5.9	69	3500	4035	1.4	2.38
M_205 30 15			8.6	13.4	3000	7.7				1	1.74
M_205 10 28		28 (39)	6.9	28.2	1000	6.8	123	5000	5535	2.5	4.35
M_205 20 28			13.0	27.3	2000	12.3				1.3	2.31
M_205 30 28			20.1	25.7	3000	18.0				0.9	1.50
M_205 10 50		50 (70)	12.4	50.4	1000	12.1	222	8000	8535	2.5	4.35
M_205 20 50			22.1	47.0	2000	20.1				1.4	2.45
M_205 30 50			33.1	41.7	3000	26.8				0.9	1.63
M_205 10 70		70 (98)	16.8	69.4	1000	16.1	310	11 000	11 535	2.6	4.49
M_205 20 70			30.7	62.9	2000	26.9				1.4	2.45
M_205 30 70			46.1	52.3	3000	33.7				0.9	1.63
M_205 10 90		90 (126)	22.1	88.2	1000	21.2	398	14 000	14 535	2.5	4.35
M_205 20 90			44.3	78.3	2000	37.7				1.3	2.18
M_205 30 90			59.0	61.6	3000	39.7				0.9	1.63

(1) Data referred to motor suspend in horizontal position in free still air, 20 °C ambient temperature

(2) Data measured at 20 °C. When "hot" consider 5 % derating

(3) Tolerance data ±10 %

# TECHNICAL CHARACTERISTICS

## MH / MB Motors, Size 205 - 15...90 Nm

### Speed Torque Curves

MH/MB205

1700 min<sup>-1</sup> 230 V - 3000 min<sup>-1</sup> 400 V

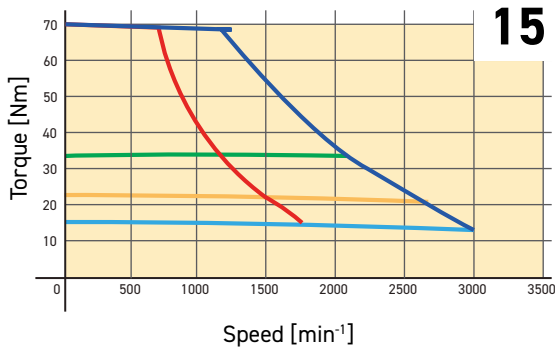

1700 min<sup>-1</sup> 230 V - 3000 min<sup>-1</sup> 400 V

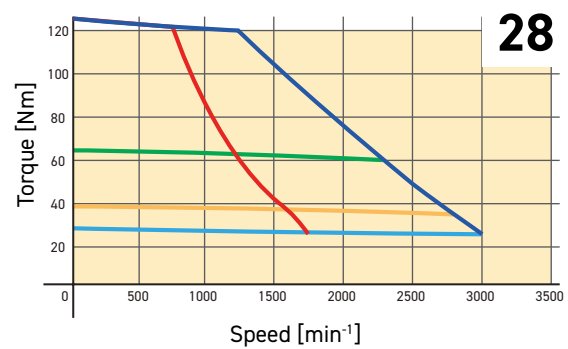

1700 min<sup>-1</sup> 230 V - 3000 min<sup>-1</sup> 400 V

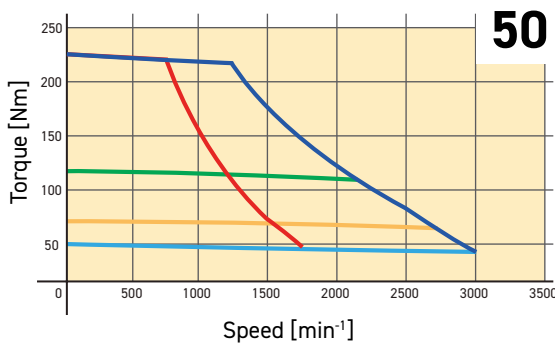

1700 min<sup>-1</sup> 230 V - 3000 min<sup>-1</sup> 400 V

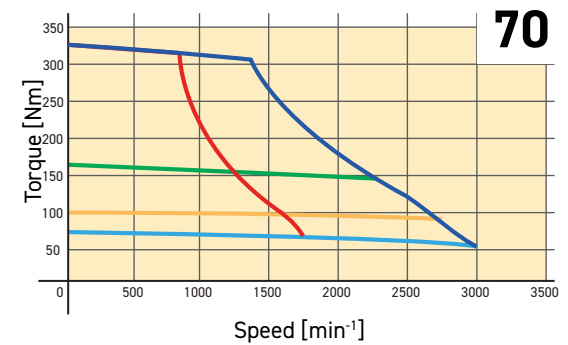

1700 min<sup>-1</sup> 230 V - 3000 min<sup>-1</sup> 400 V

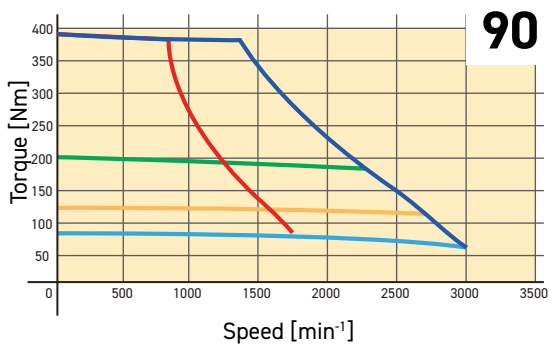

- S1 65 K, ΔT
- S3 10 %, 5 min, 400 V
- S3 10 %, 5 min, 230 V
- S3 50 %, 5 min
- S3 20 %, 5 min

# TECHNICAL CHARACTERISTICS

## MH / MB Motors, Size 265 - 75...285 Nm

### 400 VAC

Model	Size	Stall		Nominal			Peak Torque <sup>(1)</sup>	Inertia		Ke <sup>(2)(3)</sup>	Kt <sup>(2)(3)</sup>
		Torque <sup>(1)</sup>	Current	Torque <sup>(1)</sup>	Speed	Current		No brake	With brake		
		T <sub>065</sub> (T <sub>105</sub> ) [Nm]	I <sub>065</sub> [A]	T <sub>n065</sub> [Nm]	n [min <sup>-1</sup> ]	I <sub>n065</sub> [A]	T <sub>max</sub> [Nm]	J [kgmm <sup>2</sup> ]	J [kgmm <sup>2</sup> ]	Ke [Vs]	Kt [Nm/A <sub>rms</sub> ]
M_265 10 75	265	75 (100)	21.6	93	1000	21.6	168	22.4	30.8	2.92	4.91
M_265 20 75			40.5	76	2000	33.1				1.56	2.62
M_265 28 75			54	63	2800	36.5				1.17	1.96
M_265 10 150		150 (182)	36.8	150	1000	32.7	295	40.1	48.5	3.12	5.24
M_265 20 150			73.7	113	2000	49.2				1.56	2.62
M_265 28 150			98	54	2800	31.6				1.17	1.96
M_265 10 220		220 (270)	58.3	205	1000	47.6	440	57.7	66.1	2.92	4.91
M_265 18 220			97.2	131	1800	50.8				1.75	2.95
M_265 10 285		285 (340)	68.8	270	1000	58.8	530	75.3	83.7	3.12	5.24
M_265 20 285			138	130	2000	56.6				1.56	2.62

## MH / MB Motors, Fan cooled versions Size 265 - 145...580 Nm

### 400 VAC

Model	Size	Stall		Nominal			Peak Torque <sup>(1)</sup>	Inertia		Ke <sup>(2)(3)</sup>	Kt <sup>(2)(3)</sup>
		Torque <sup>(1)</sup>	Current	Torque <sup>(1)</sup>	Speed	Current		No brake	With brake		
		T <sub>065</sub> (T <sub>105</sub> ) [Nm]	I <sub>065</sub> [A]	T <sub>n065</sub> [Nm]	n [min <sup>-1</sup> ]	I <sub>n065</sub> [A]	T <sub>max</sub> [Nm]	J [kgmm <sup>2</sup> ]	J [kgmm <sup>2</sup> ]	Ke [Vs]	Kt [Nm/A <sub>rms</sub> ]
M_SV 265 09 145	265	145	31.3	143	900	33.3	305	22.4	30.8	2.92	4.91
M_SV 265 17 145			58.7	128	1700	55.8				1.56	2.62
M_SV 265 26 145			78.3	121	2600	70.1				1.17	1.96
M_SV 265 09 300		310	62.8	292	900	63.6	620	40.1	48.5	3.12	5.24
M_SV 265 17 300			127.3	268	1700	113.5	620			1.56	2.62
M_SV 265 26 300			161.9	235	2600	136.5	600			1.17	1.96
M_SV 265 09 440		440	95	395	1000	91.7	840	57.7	66.1	2.92	4.91
M_SV 265 17 440			158.3	364	1700	141	840			1.75	2.95
M_SV 265 26 440			237.5	310	2600	180.2	750			1.17	1.96
M_SV 265 09 580		580	117.4	535	900	126.3	1100	75.3	83.7	3.12	5.24
M_SV 265 17 580			239.3	487	1700	212.3	950			1.56	2.62
M_SV 265 26 580			313.1	339	2600	197	880			1.17	1.96

(1) Data referred to motor suspend in horizontal position in free still air, 20 °C ambient temperature

(2) Data measured at 20 °C. When "hot" consider 10 % derating

(3) Tolerance data ±10 %

(4) Data given at 100 min<sup>-1</sup>

### Speed Torque Curves:

On request only.

# DIMENSIONS

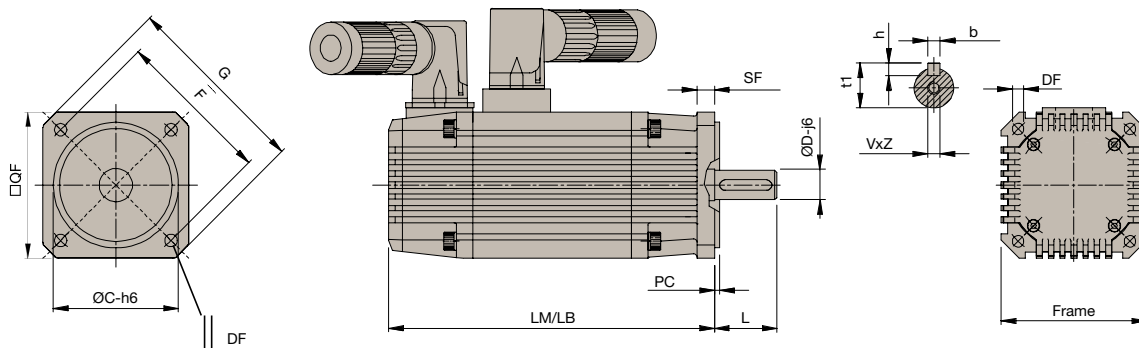

Motor - Size	LM/LB	Weight	DxL	bxh	t1	VxZ	C	F	DF	G	SF	PC	QF	Order code QF	
145	04	200/274	8	19x40 24x50 28x60	6x6 8x7	21.5 27 31	M6x16 M8x19 M10x22	130	165	11.5	200	12	3.5	145	5
	08	231/305	12												
	15	292/366	18												
	22	354/428	23												
	28	416/490	28												
205	15	239/338	20	38x80 42x110	10x8 12x8	41 45	M12x32 M16x40	180	215	14	250	18	4	205	5
	28	273/372	29												
	50	342/441	44												
	70	411/510	59												
	90	480/579	74												
265	75	340/475	89	48X110	14x9	51.5	M16x40	250	300	19	342	35	4	264	5
	150	447/582	126												
	220	554/689	164												
	285	661/796	203												

**LM:** Motor length without brake with resolver

**LB:** Motor length with brake with resolver

**DxL:** Shaft

**bxh:** Key

**t1:** Overall shaft height

**VxZ:** Shaft hole depth

**C:** Center

**F:** Distance between center of holes clamp

**DF:** Fixing holes

**G:** Dimension in diagonal

**SF:** Flange thickness

**PC:** Centering depth

**QF:** Flange square

mm for dimensions, kg for weight

# OPTIONS

Parker Mx family motors are available with standard and custom options to adapt motor on your application. If the option for your application is not listed, please consult our technical department.

## Holding Brake

All MH, MB motors are available with an optional holding brake. Two different brake types exist, standard holding brake (option A) and special brake (option B) depending on the features of your application needs.

Incorporated into the motor is the fail-safe holding brake (supply voltage 24 VDC  $\pm$ 10 %) which is applied when no voltage is present. Because of the power taken by the brake, torque values must be reduced by 5 % (10 % for size 265). The holding brake shall be used with the motor only at a standstill and not for dynamic braking. For maintenance, please refer to technical manual.

Holding Brake <sup>(1)</sup>	Option	Voltage [V]	Current @20 °C [A]	Torque @20 °C [Nm]	Added Length [mm]	Added Weight [kg]	Torque derating of motor
M_145_A_04	A	24 $\pm$ 10 %	1.8	4	74	5	5 %
M_145_A_08				8			
M_145_A_15				15			
M_145_A_22				22			
M_145_A_28				28			
M_145_B	B	24 $\pm$ 10 %	0.8	22	74	5	5 %
M_205_B	B	24 $\pm$ 10 %	2.1	120	99	14	5 %
M_265_A_75	A	24 $\pm$ 10 %	4.8	225	135	30	10 %
M_265_A_150				450		35	
M_265_A_220							
M_265_A_285							
M_265_B	B	n.a.					

(1) If more than one option is required, please check with our technical department the feasibility.

## Fan cooling for Mx145 – Mx205

For high duty cycle applications, Parker offers 2 different types of cooling option: servo-ventilated, self-ventilated. Please refer to motors in the table below.

With servo-ventilated the motors (order Code M\_SV), an increase of 25 % torque and current based on nominal values (except for the maximum torque and current data) is provided. The servo-ventilated 205 motor is equipped with an external condenser for starting the fan.

With the self-ventilated option (order Code M\_V), the torque is increased proportionally to the nominal speed.

Motor MB / MH	Option <sup>(1)</sup>	Voltage	Current [A]	Frequency [Hz]	Speed [min <sup>-1</sup> ]	Added Length [mm]	Added Weight [kg]	Torque increasing of motor
145	SV	230 VAC Single Phase $\pm$ 10 %	0.35	50	3000	97	2	25 %
	V	n.a.	n.a.	n.a.	n.a.	44	0.55	Depending of speed
205	SV	230 VAC Single Phase $\pm$ 10 %	0.22	50	3000	109	2.2	25 %
	V	n.a.	n.a.	n.a.	n.a.	54	1.1	Depending of speed

(1) If more than one option is required, please check with our technical department the feasibility.

## Feedback options

M\_ motors are available with standard resolver feedback, but for different type of application we can offer the following types of feedback:

- Incremental Encoder with hall sensors
- Hiperface absolute encoder (single or multi-turn), DSL®
- EnDat absolute encoder (single or multi-turn)

### Resolver

Poles	2
Transformation ratio	0.5
Operating temperature	-50...+150 °C
Motor associations	all sizes

### Incremental Encoder with Hall Sensor

Code	A1	A2	A3
Resolution [C/T]	2000	2048	4096
Poles	8		
System Accuracy	±32"	±32"	±16"
Voltage	+5 VDC ±5 % - 200 mA		
Reference Mark	Yes		
Max Speed [min <sup>-1</sup> ]	6000		
Output Circuit	Line drive differential mode 20 mA		
Operating Temperature	-20...+100 °C	-20...+85 °C	-20...+100 °C
M_ Motors Associations			
M_145	✓	✓	✓
M_205	✓	✓	✓
M_265	-	-	-

### Hiperface Absolute Encoder

Code	S1	S2	A6	A7	S5	S6	L6
Type	Optical						
Turn	Single	Multi	Single	Multi	Single	Multi	Multi
Incremental Signals	1 V <sub>pp</sub>				-	-	-
Line Count	1024				-	-	-
Resolution	32 768 (15 bit)		32 768 (15 bit)		262 144 (18 bit)		20 bit
Absolute rotation	1	4096	1	4096	1	4096	4096
System Accuracy	±45"				±40"		±50"
Power Supply	8 VDC				7...12 VDC		
Max Speed [min <sup>-1</sup> ]	6000				-		9000
Temperature	-20...+115°C				-20...+105°C		-40°C...+115°C
Safety integrity level	SIL2 (IEC 61508), SILCL2 (IEC 62061)		Not Available		SIL2 (IEC 61508), SILCL2 (IEC 62061)		
MB / MH Motors Associations							
M_145	Δ 19 mm	Δ 19 mm	Δ 19 mm	Δ 19 mm	Δ 19 mm	Δ 19 mm	Δ 19 mm
M_205	Δ 19 mm	Δ 19 mm	Δ 19 mm	Δ 19 mm	Δ 19 mm	Δ 19 mm	Δ 19 mm
M_265	-	-	-	-	-	-	-

- Not possible

✓ Possible without increment

Δ Possible with increment motor length

**EnDat Absolute Encoder**

Code	B9	D5
Type	Inductive	Optical
Turn	Multi	Multi
Incremental Signals	1V <sub>PP</sub>	
Line Count	32	512
Positions per revolutions	524288 (19bit)	8192 (13 bit)
Distinguishable revolutions	4096	
System Accuracy	±400"	±60"
Power Supply	5 VDC	
Max Speed [min <sup>-1</sup> ]	12 000	7000
Temperature	-20...+115 °C	-30...+115 °C
Absolute position values	EnDat 2.1	EnDat 2.2
Safety integrity level:	not available	
M_ Motors Associations		
M_145	✓	Δ 19 mm
M_205	Δ 19 mm	Δ 19 mm
M_265	-	✓

**Technical specification for high inertia**

Option Inertia	Added ...	Unit	145					205				
			04	08	15	22	28	15	28	50	70	90
M	Inertia	[kgmm <sup>2</sup> ]	790					4400				
	Length	[mm]	0					0				
	Weight	[kg]	0.990					2.065				
ML	Inertia	[kgmm <sup>2</sup> ]	1770			n.a.		12 100			n.a.	
	Length	[mm]	74			n.a.		99			n.a.	
	Weight	[kg]	3.3	3.6		n.a.		7.6	11.9		n.a.	

## Layout and connectors

M\_ motors are available with different combinations of connectors and layout, depending of size of motor and the application



	2x Parallel upright connectors	Terminal box rear facing	Terminal box forward facing	Terminal box forward facing	Terminal box forward facing	Hiperface DSL® connector
	2l	3M	3MB	3l	6l	IZ
MH_145	-	-	-	✓	-	✓
MH_205	-	-	-	✓◆	-	✓
MH_205 / 90Nm	-	-	-	-	✓	-
MH_265	-	✓	-	-	-	-
MB_145	✓	✓	✓	✓	-	✓
MB_205	-	✓	✓	✓◆	-	✓
MB_205 / 90Nm	-	-	-	-	✓	-
MB_265	-	✓	-	-	-	-
ME_145	✓	-	-	✓	-	✓
ME_205	-	-	-	✓◆	-	✓
ME_205 / 90Nm	-	-	-	-	✓	-
ME_265	-	✓	-	-	-	-

- Not possible
- ✓ Possible without increment
- ◆ Not possible with torque 90Nm

## Shaft

M\_ motors are available with or without key option; shafts are available in different sizes suitable for your existing machine or gearbox

# ORDER CODE

## MH / MB Motors

To ensure that you select the correct motor we recommend that you have the following information.

- Diagram speed / time of load cycle to identify the type of the cycle (S1, S3 or others)
- Information about inertia load system
- Check the duty cycle - acceleration/deceleration
- Calculate the average torque and peak torque of the system
- Calculate the average speed and maximum speed of the cycle
- Check the temperature and altitude of environment / application
- Check the mechanical compatibility

With these preliminary data you can start to choice the motor (with the correct drive) for your application.

	1	2	3	4	5	6	7	8	9	10	11	12	13	14	15	16	17	18	
Order example	MH	x	A	V	205	11	28	5	9		2I			64	A1				2

<b>1 Type Of Motor (mandatory field)</b>	<b>MH</b>	Motor with Resolver MH Series for PSD/C3
	<b>MB</b>	Motor with Resolver MB Series for TPDM/SLVDN
	<b>ME</b>	Motor with Encoder ME Series for TPDM/SLVDN
<b>2 EX Protection</b>	Empty field	Standard motor
<b>3 Brake Option</b>	empty field	No Brake Option
	<b>A</b>	Motor with Holding Brake (brakes when the supply voltage is 0)
	<b>B</b>	Motor with Holding Brake (size 145 up to 15Nm and 205)
<b>4 Cooling Option</b>	empty field	no cooling option
	<b>V</b>	Motor with shaft-drive fan cooling
	<b>SV</b>	Motor with (single-phase) motorised fan cooling
<b>5 Motor Frame Size (mandatory field)</b>	<b>145</b>	Torque range 4.5...28 Nm
	<b>205</b>	Torque range 15...90 Nm
	<b>265</b>	Torque range 75...265 Nm
<b>6 Winding (mandatory field)</b>	<b>nn</b>	min <sup>-1</sup> (x100) except for size 205 1150 min <sup>-1</sup> which is only 11
<b>7 Motor Torque (mandatory field)</b>	<b>nn</b>	Torque in Nm
<b>8 Flange (mandatory field)</b>	<b>5</b>	B5 Flange
<b>9 Shaft (mandatory field)</b>	<b>19</b>	19x40 mm for size 145
	<b>24</b>	24x50 mm for size 145
	<b>28</b>	28x60 mm for size 145
	<b>38</b>	38x80 mm for size 205
	<b>42</b>	42x110 mm for size 205
	<b>48</b>	48x110 mm for size 265
	<b>A*</b>	Special shaft under request
<b>10 Key Shaft option</b>	empty field	Shaft with key
	<b>S</b>	Shaft without key
<b>11 Layout - Connectors (mandatory field)</b>	<b>2I</b>	Interconnectron rotatables receptacles (not for size 265 and 205 with brake)
	<b>3M</b>	Terminal Box - opposite shaft glands
	<b>3MB</b>	Terminal Box -toward shaft glands
	<b>3I</b>	Terminal Box + Interconnectron 90° (not for size 265)
	<b>3MBS</b>	Terminal Box + Interconnectron 90° (only for size 265)
<b>12 Female connectors option</b>	empty field	With Female / flying connectors
	<b>W</b>	Without Female / flying connectors
<b>13 Form Option</b>	empty field	no Foot Mount Option
	<b>3</b>	B3 - Foot Mount Option
<b>14 Protection Degree (mandatory field)</b>	<b>64</b>	IP64
	<b>65</b>	IP65

**15 Feedback**

empty field	Resolver (Standard) not for ME motors
<b>A1</b>	Tamagawa OIH48 2000 ppr / on request - No Stock
<b>A2</b>	Tamagawa OIH48 2048 ppr for size 105/145/205
<b>A3</b>	Tamagawa OIH48 4096 ppr for size 105/145/205
<b>A6</b>	Stegman SRS50 Hiperface Single-Turn for size 70/105/145/205
<b>A7</b>	Stegman SRM50 Hiperface Multi-Turn for size 70/105/145/205
<b>B9</b>	SinCos EnDat Encoder Multi-Turn - HEIDENHAIN EQI1331
<b>D5</b>	SinCos EnDat Encoder Multi-Turn - HEIDENHAIN EQN1325
<b>S1</b>	SinCos Hiperface Encoder Single-Turn - STEGMANN SRS50S
<b>S2</b>	SinCos Hiperface Encoder Multi-Turn - STEGMANN SRS50S
<b>S5</b>	Hiperface DSL® Encoder Feedback SIL2 262 144 ppr - Single Turn
<b>S6</b>	Hiperface DSL® Encoder Feedback SIL2 262 144 ppr - Multi Turn
<b>L6</b>	Hiperface DSL® Encoder Feedback SIL2 1 048 576ppr x 4096 Multi Turn - for high environment requirements

**16 Option Inertia**

empty field	Standard Inertia
<b>M</b>	Medium Inertia
<b>ML</b>	High Inertia

**17 Special Option**

empty field	No Special Option
-------------	-------------------

**18 Voltage**

<b>2</b>	220-230 V
<b>4</b>	380-400 V

**19 Feedback sensor (only for Mx265)**

<b>-290</b>	Resolver feedback
<b>-291</b>	SinCos EnDat Encoder Multi-Turn - HEIDENHAIN EQN1325

## Motor Power Cable for MH / MB Motors

	1	2	3	4		5		6		7		8
Order example	<b>CBM</b>	<b>005</b>	<b>H</b>	<b>D</b>	-	<b>M23</b>	-	<b>PSX</b>	-	<b>0010</b>	-	<b>00</b>

### 1 Power Cable Drive

**CBM** Power cable drive

### 2 Section [mm<sup>2</sup>]

**005** 0.5 mm<sup>2</sup>

**007** 0.7 mm<sup>2</sup>

**010** 1 mm<sup>2</sup>

**015** 1.5 mm<sup>2</sup>

**025** 2.5 mm<sup>2</sup>

### 3 Cable

**S** Standard

**H** High Flex

### 4 Brake

**0** Power cable standard - without brake

**B** Power cable standard - with brake

**D** DSL® Power cable with brake

### 5 Motor Connector

**M23** M23 Interconnectron connector

**M40** M40 Interconnectron connector

### 6 Drive

**PSX** Parker PSD1-S

**PMX** Parker PSD1-M

**SDX** Parker Servonet DC

### 7 Length

**0000** Cable length 4 digits (example 50 m = 0500)\*

### 8 Special Execution

**00** Standard

\* Available length in meter: 1; 2.5; 5; 7.5; 10; 15; 20; 25; 30; 35; 40; 45; 50

## Motor Feedback Cable for MH / MB Motors

	1	2	3	4		5		6		7		8
Order example	<b>CBF</b>	<b>RED</b>	<b>H</b>	<b>0</b>	-	<b>M23</b>	-	<b>PSX</b>	-	<b>0010</b>	-	<b>00</b>

<b>1 Power Cable Drive</b>	<b>CBF</b>	Feedback cable drive
<b>2 Feedback</b>	<b>RED</b>	Resolver
<b>3 Cable</b>	<b>H</b>	High Flex
<b>4 Brake</b>	<b>0</b>	Power cable standard - without brake
<b>5 Motor Connector</b>	<b>M23</b>	M23 Interconnectron connector
<b>6 Drive</b>	<b>PSX</b>	Parker PSD1-S
	<b>PMX</b>	Parker PSD1-M
	<b>SDX</b>	Parker Servonet DC
<b>7 Length</b>	<b>0000</b>	Cable length 4 digits (example 50 m = 0500)*
<b>8 Special Execution</b>	<b>00</b>	Standard

\* Available length in meter: 1; 2.5; 5; 7.5; 10; 15; 20; 25; 30; 35; 40; 45; 50





[www.parker.com](http://www.parker.com)

192-061012 02/2026

© 2026 Parker Hannifin EMEA Sarl. All Rights Reserved.