

# ProSpool

Process to Instrument Valve



## Customer Value Proposition:

The Parker ProSpool features a combined, single-piece valve consisting of a double block and bleed configuration with an integral flushing spool. It can be easily installed and, having fewer component parts, reduces inventory and purchase orders.

With the captive stud option torquing of the nuts is simplified. Extremely useful in restricted spaces.



## Product Features:

- Single piece forged body
- Flushing valves can be either ball or needle
- Optional captive studs on outlet. Reduction in install time, reduces costs
- Flushing valves are available with compression fitting ends removing NPT threads
- Flushing valves can be factory welded thus removing NPT threads and guaranteeing valve handle orientation
- Outlet bore is machined to give maximum flushing potential



ENGINEERING YOUR SUCCESS.

# Benefits of ProSpool over traditional hook up

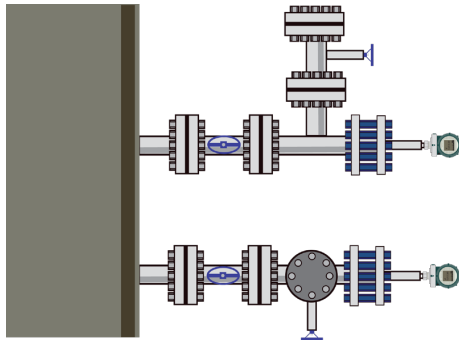

Traditional hook up

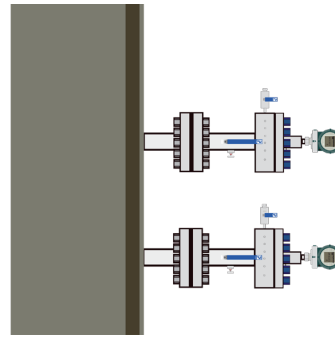

ProSpool hook up

Feature	Benefit	Value
Fewer joints	Reduction in potential leak paths	Performance and Reliability Lower Overall Cost
Less weight	Reduction in support Easier to manipulate Reduction in material cost	Ease of Assembly Performance and Reliability Lower Overall Cost
Less space	Reduction in installation time	Ease of Assembly Lower Overall Cost

# How to Order

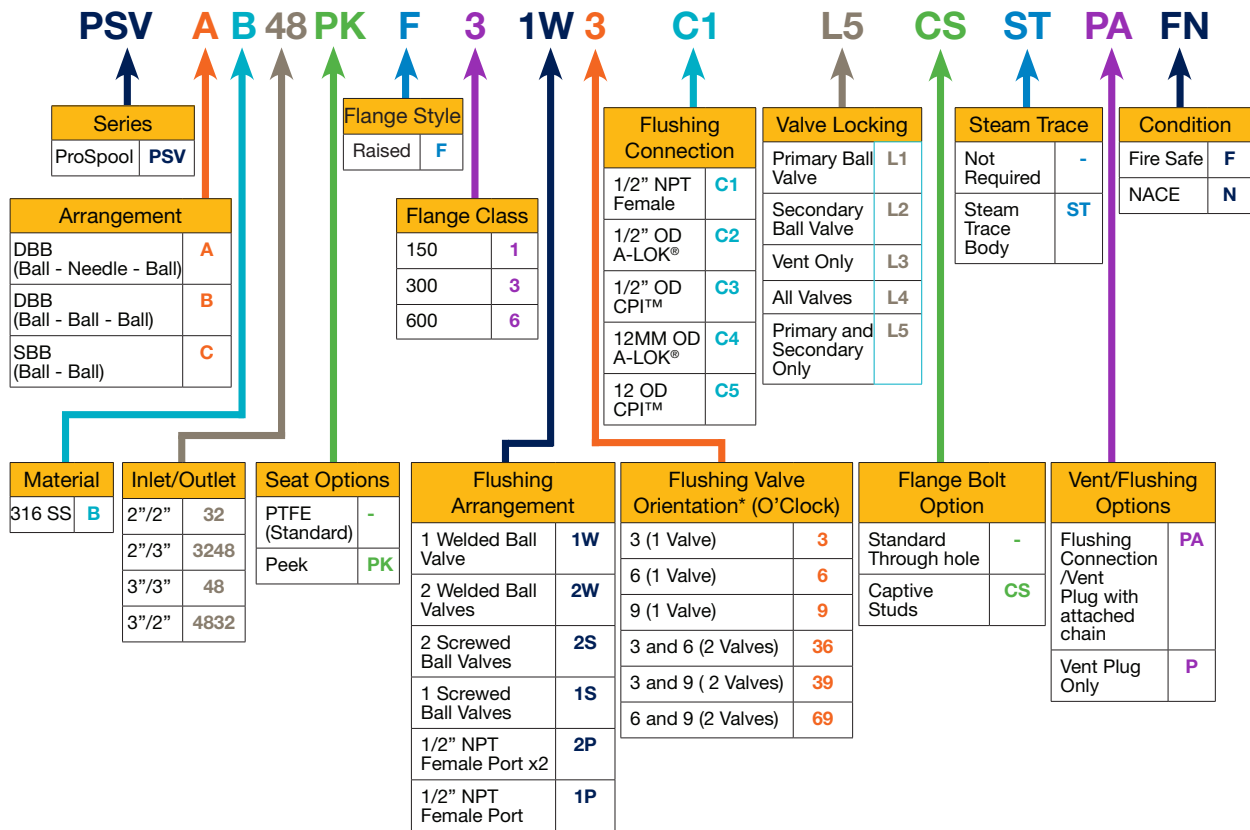

## \* Flushing Valve Orientation

A clock face has been used to describe the flushing valve orientation. The 12 o'clock position will be in line with the primary block valve as demonstrated below, with the flushing valve at either the 3, 6 or 9 o'clock position. For two valves 90 degrees or 180 degrees apart use two clock positions.

No flushing valves at the 12 o'clock position due to the primary valve handle covering the outlet flange in the open position.

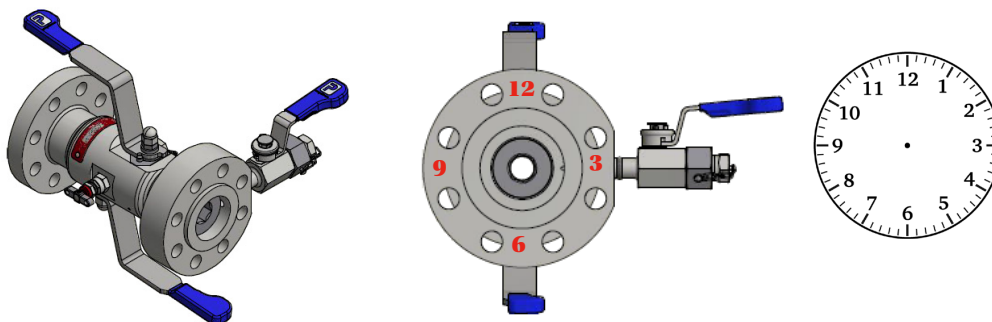

Flushing valve orientation at 3 O'Clock position



Parker Hannifin Manufacturing Ltd  
**Instrumentation Products Division, Europe**  
Pottington Business Park  
Barnstaple, EX31 1NP  
United Kingdom  
phone 0044 (0)1271 313131

[www.parker.com/ipd](http://www.parker.com/ipd)

Parker Hannifin Corporation  
**Instrumentation Products Division**  
1005 A Cleaner Way  
Huntsville, AL 35805  
USA  
phone: +1 (256) 881-2040