

Hi-Pro Manifolds for High Performance Instrument Control

Catalog 4190-HBM





aerospace
climate control
electromechanical
filtration
fluid & gas handling
hydraulics
pneumatics
process control
sealing & shielding

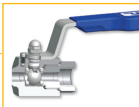
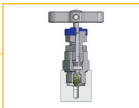

ENGINEERING YOUR SUCCESS.

Hi-Pro Manifolds

Contents

Page 3 Introduction	
Page 4 Hi-Pro Ball valve construction and P/T graph	
Page 5 "H" series needle construction, handle options and P/T graph	
Page 6/7 Hi-Pro single block and bleed manifolds	
Page 8/9 Hi-Pro double block and bleed manifolds	
Page 10/11 Manifold and valve options and spares	

Hi-Pro Manifolds

Introduction

With many years of manifold development and manufacture Parker Hannifin are able to offer the most comprehensive range of block and bleed and double block and bleed manifolds to suit all types of instrumentation installations, specifications and applications.

Now consolidated into one catalog, selection can be made from a comprehensive range of bodies with a variety of connections and valve positions, optimising installation and access opportunities.

Designed to reduce installation costs and improve safety performance, the consolidation of valves into one unit provides you with a combination of instrument isolation together with bleed/vent and test facilities.

In addition to manufacturing manifolds Parker also produce a comprehensive range of single and twin ferrule high integrity tube fittings. Manufactured in a variety of materials these products are used extensively in the oil, gas, petro-chem, power, processing and many other markets.

By integrating these products, instrument manifolds and tube fittings, Parker can offer unique connection combinations which are specifically designed to eliminate site assembled threaded connectors, ingress of debris and contamination from thread sealant materials which often result in instrument failure, replacement and downtime. Eliminating the use of taper threads, factory assembled and tested connections will ensure improved performance through simpler assembly and installation procedures. This system provides total flexibility of tubing position with positive leak proof connections.

Continuous product development may from time to time necessitate changes in the details contained in this catalogue. Parker Hannifin reserve the right to make such changes at their discretion and without prior notification.

All dimensions shown in this catalogue are approximate and subject to change.



WARNING

FAILURE, IMPROPER SELECTION OR IMPROPER USE OF THE PRODUCTS AND/OR SYSTEMS DESCRIBED HEREIN OR RELATED ITEMS CAN CAUSE DEATH, PERSONAL INJURY AND PROPERTY DAMAGE.

This document and other information from Parker Hannifin Corporation, its subsidiaries and authorized distributors provide product and/or system options for further investigation by users having technical expertise. It is important that you analyze all aspects of your application and review the information concerning the product or system in the current product catalog. Due to the variety of operating conditions and applications for these products or systems, the user, through its own analysis and testing, is solely responsible for making the final selection of the products and systems and assuring that all performance, safety and warning requirements of the application are met.

The products described herein, including without limitation, product features, specifications, designs, availability and pricing, are subject to change by Parker Hannifin Corporation and its subsidiaries at any time without notice.

Offer of Sale

The items described in this document are hereby offered for sale by Parker Hannifin Corporation, its subsidiaries or its authorized distributors. Any Order accepted by Parker Hannifin will be subject to our terms and conditions of sale, copy available on request.

Hi-Pro Manifolds

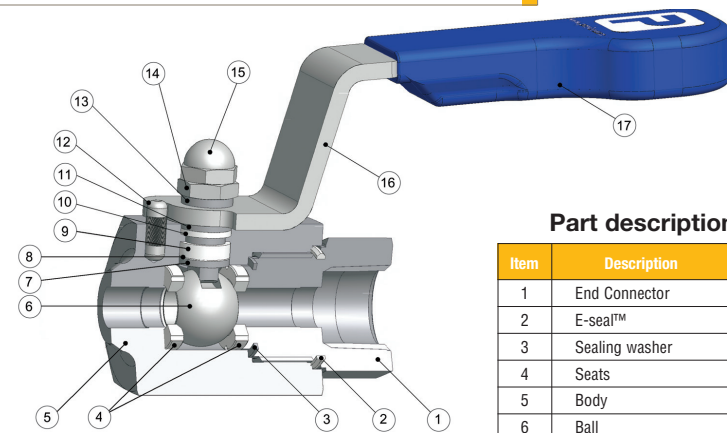

Part description

Item	Description
1	End Connector
2	E-seal™
3	Sealing washer
4	Seats
5	Body
6	Ball
7	Anti blowout stem
8	Thrust Seal
9	Gland packing
10	Upper gland packing
11	Thrust bush
12	Stop pin
13	Thrust bush
14	Lock nut
15	Locking dome nut
16	Handle
17	Handle grip

Specifications

- 316 Stainless steel construction
 - Maximum cold working pressure rating 6,000 psig (414 barg) with P.T.F.E. seats*
 - Temperature rating PTFE seats -54°C to +204°C (-65°F to +400°F)*
 - Maximum cold working pressure rating 10,000 psig (689 barg) with PEEK seats*
 - Temperature rating PEEK seats -54°C to +232°C (-65°F to +450°F)*
- *always refer to P/T graph

Features

- Two piece body design - minimal leakage paths
- 4:1 Pressure boundary designed safety factor
- Designed to comply with requirements of ANSI/ASME B16.34 where applicable
- Bi-directional
- PEEK and PTFE standard ball seat materials.
- PTFE and Graphoil gland packings
- Bubble tight shutoff
- Floating ball principal with dynamic response seats featuring inherent self relief
- Anti blowout stem
- Integral compression ends available eliminating taper threads and thread sealants
- Low torque operation
- Quarter turn positive stop handle with ergonomically designed protective sleeve
- Full hydrostatic and low pressure air tested
- Connector thread environmentally sealed
- Anti static
- Optional firesafe designed to meet API 607, BS6755 Pt2

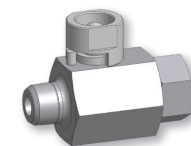

Spanner actuation

Performance data pressure vs temperature

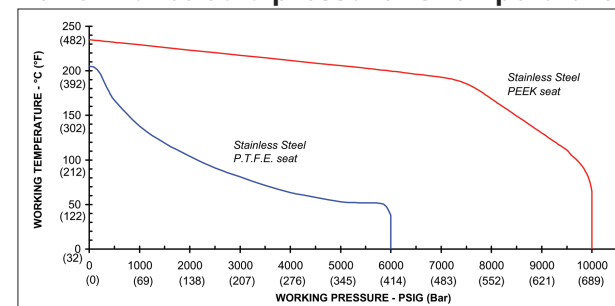

When selecting products for specific applications users should refer to our notice at the bottom of page 3

Hi-Pro Manifolds

Standard manifold globe style bonnet design

For safe reliable and repeatable performance

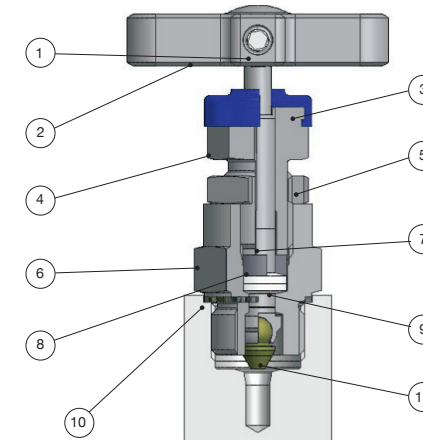

Part description

Item	Description
1	Positive handle retention
2	"T" bar
3	Dust Cap
4	Gland packing adjuster
5	Gland adjuster lock nut
6	Valve Bonnet
7	Anti blowout spindle
8	Thrust Bush
9	Gland packing (adjustable)
10	Bonnet/body washer
11	Spindle tip

Pressure vs temperature

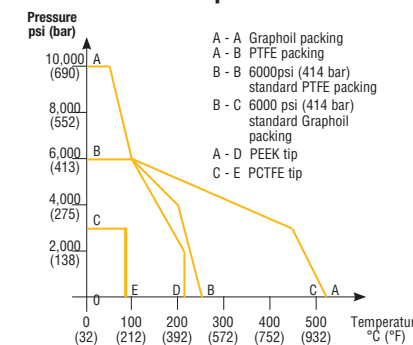

Anti tamper spindle

For key only - part no. ATHKEY/1

Retro-fit kit part number KITATK with key

Handwheel	Lockable handwheel	T bar handle locking
Retro-fit kit part number KITHW	Retro-fit kit part number KITLHW	Retro-fit kit part number KITTHL

When selecting products for specific applications users should refer to our notice at the bottom of page 3

Hi-Pro Manifolds

Block and bleed remote mount static pressure manifolds

Purpose

This series of manifolds combines isolate in the form of a ball valve and bleed/vent in a choice of ball or needle into one block for interface with pressure measurement transmitters, gauges and switches for applications up to 10,000psig (689 barg)

A variety of end connections can be provided including NPT as standard with optional BSPT_r and BSPP. Parker can also combine single or twin ferrule integral fitting technology into the product offering the end user the benefit of leak path reduction and contaminant free connections by eliminating taper threads.

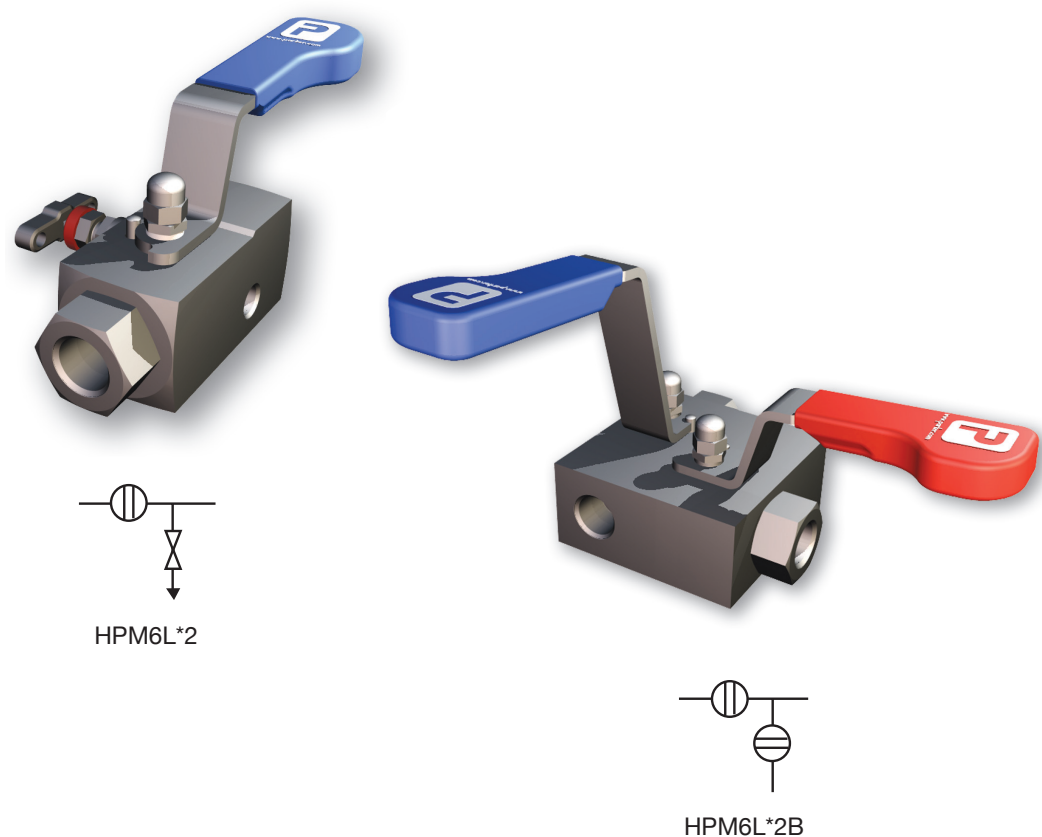

Hi-Pro Manifolds

Block and bleed remote mount static pressure manifolds

Series HPM6L*2B

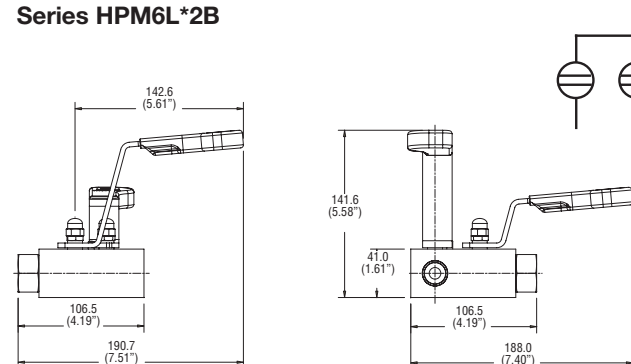

Standard Product Specifications

Part No. HPM6LS2B: 316 Stainless steel construction with single isolate and bleed/vent 10mm bore ball valves, PTFE packing, PTFE seats. Process and instrument connection 1/2" NPT female, bleed/vent 1/4" NPT female. Maximum cold working pressure 6,000 psig (414 barg).

Part No. HPM6LS2BHP: 316 Stainless steel construction with single isolate and bleed/vent 10mm bore ball valves, PTFE packing, PEEK seats. Process and instrument connection 1/2" NPT female, bleed/vent 1/4" NPT female. Maximum cold working pressure 10,000 psig (689 barg).

Series HPM6L*2

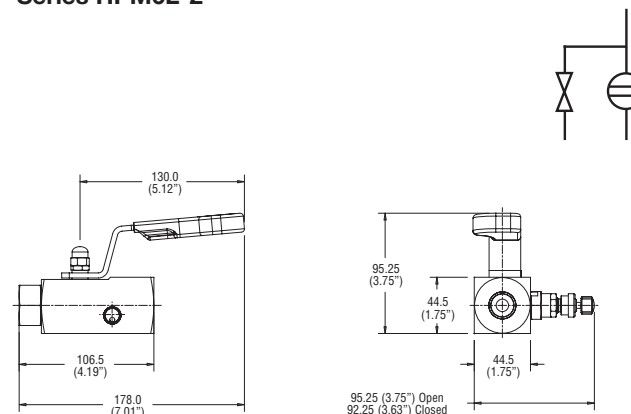

Standard Product Specifications

Part No. HPM6LS2: 316 Stainless steel construction with single isolate 10mm bore ball valve, PTFE packing, PTFE seats. Bleed/vent valve globe pattern needle, none rotating self-centering tip, T bar handle, PTFE packing and metal/metal seat. Process and instrument connection 1/2" NPT female, bleed/vent 1/4" NPT female. Maximum cold working pressure 6,000 psig (414 barg).

Part No. HPM6LS2HP: 316 Stainless steel construction with single isolate 10mm bore ball valve, PTFE packing, PEEK seats. Bleed/vent valve globe pattern needle, none rotating self-centering tip, T bar handle, PTFE packing and metal/metal seat. Process and instrument connection 1/2" NPT female inlet, bleed/vent 1/4" NPT female. Maximum cold working pressure 10,000 psig (689 barg).

Standard range part numbers

Part No.	Standard connections		
	Inlet (NPT)	Outlet (NPT)	Bleed/test (NPT)
HPM6L*2B	1/2" female	1/2" female	1/4" female
HPM6L*2BHP	1/2" female	1/2" female	1/4" female
HPM6L*2	1/2" female	1/2" female	1/4" female
HPM6L*2HP	1/2" female	1/2" female	1/4" female

*Insert material designator, see page 10

Function
Blue – isolate,
Red – drain/bleed

Features

- Standard high performance bonnet design
- Colour coded valve function identification
- Alternative materials of construction available
- Optional port sizes and thread forms available: BSPT_r, BSPP
- Socket and butt weld connections available
- PTFE connections available (see page 10)
- Blank and bleed plugs available
- NACE certified on request
- Optional cleaned and lubricated suitable for Oxygen service
- Heat code traceable body and bonnet
- Optional Fire safe design to meet API 607, BS6755 Pt2

Hi-Pro Manifolds

Double block and bleed remote mount static pressure manifolds

Purpose

This series of manifolds combines double isolate (Primary and Secondary) and bleed/vent in a combination of ball and needle into one block, for interface with pressure measurement transmitters, gauges and switches for applications up to 10,000psig (689 barg).

A variety of end connections can be provided including NPT as standard with optional BSPT_r and BSPP. Parker can also combine single or twin ferrule integral fitting technology into the product offering the end user the benefit of leak path reduction and contaminant free connections by eliminating taper threads.

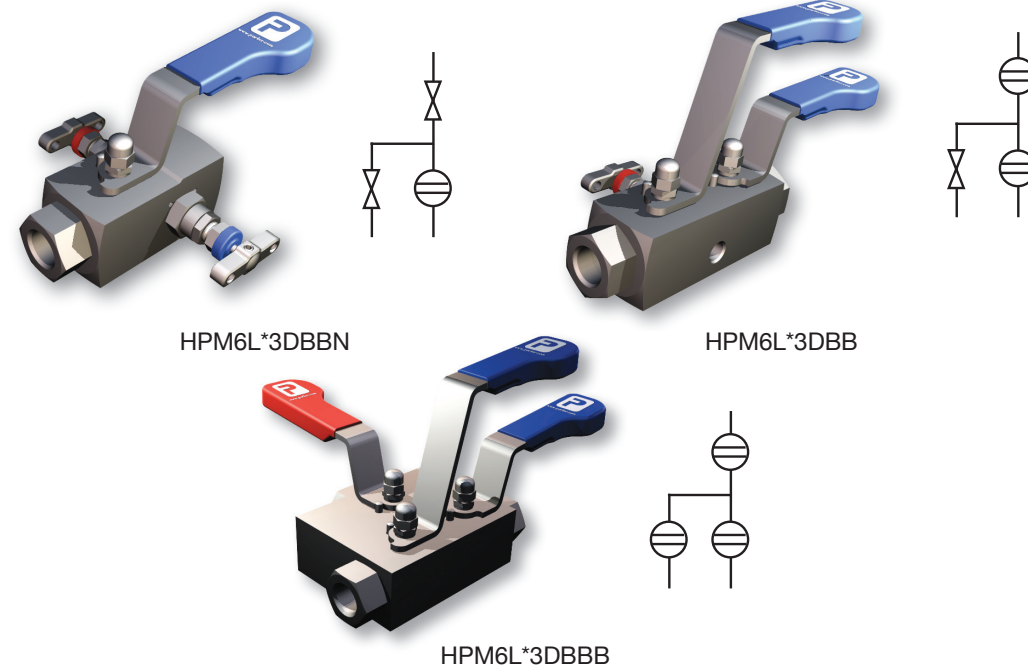

Standard range part numbers

Part No.	Standard connections		
	Inlet (NPT)	Outlet (NPT)	Bleed/test (NPT)
HPM6L*3DBBN	1/2" female	1/2" female	1/4" female
HPM6L*3DBBNHHP	1/2" female	1/2" female	1/4" female
HPM6L*3DBB	1/2" female	1/2" female	1/4" female
HPM6L*3DBBHHP	1/2" female	1/2" female	1/4" female
HPM6L*3DBBB	1/2" female	1/2" female	1/4" female
HPM6L*3DBBBHHP	1/2" female	1/2" female	1/4" female

*Insert material designator, see page 10

Function
Blue – isolate,
Red – drain/bleed

Features

- Standard high performance design
- Colour coded valve function identification
- Alternative materials of construction available
- Optional port sizes and thread forms available: BSPT_r, BSPP
- Socket and butt weld connections available
- PTFE connections available (see page 10)
- Blank and bleed plugs available
- NACE certified on request
- Optional cleaned and lubricated suitable for Oxygen service
- Heat code traceable body and bonnet
- Optional fire safe design to meet API 607, BS6755 Pt2

8

Hi-Pro Manifolds

Double block and bleed remote mount static pressure manifolds

Series HPM6L*3DBBN

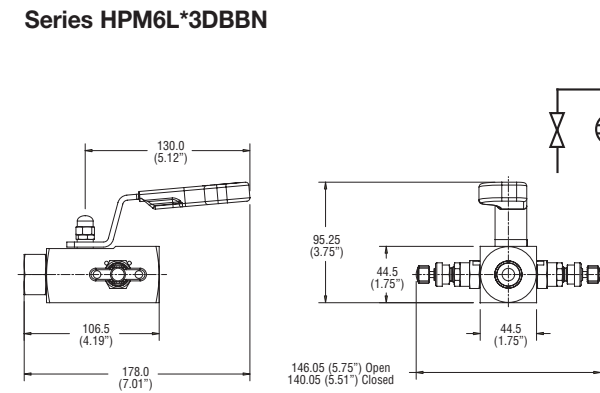

Standard Product Specifications

Part No. HPM6LS3DBBN: 316 Stainless steel construction with primary isolate 10mm bore ball valves, PTFE packing, PTFE seats. Secondary isolate and bleed/vent valve globe pattern needle, none rotating self centering tip, T bar handle, PTFE packing and metal/metal seat. Process and instrument connection 1/2" NPT female, bleed/vent 1/4" NPT female. Maximum cold working pressure 6,000 psig (414 barg).

Part No. HPM6LS3DBBNHHP: 316 Stainless steel construction with primary isolate 10mm bore ball valves, PTFE packing, PEEK seats. Secondary isolate and bleed/vent valve globe pattern needle, none rotating self centering tip, T bar handle, PTFE packing and metal/metal seat. Process and instrument connection 1/2" NPT female, bleed/vent 1/4" NPT female. Maximum cold working pressure 10,000 psig (689 barg).

Series HPM6L*3DBB

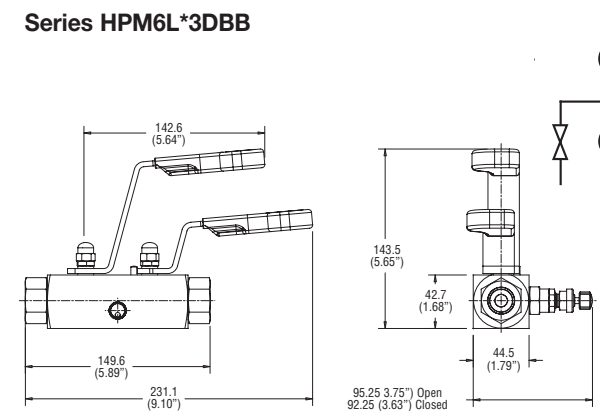

Standard Product Specifications

Part No. HPM6LS3DBB: 316 Stainless steel construction with double isolate 10mm bore ball valves, PTFE packing, PTFE seats. Single bleed/vent valve globe pattern needle, none rotating self-centering tip, T bar handle, PTFE packing and metal/metal seat. Process and instrument connection 1/2" NPT female, bleed/vent 1/4" NPT female. Maximum cold working pressure 6,000 psig (414 barg).

Part No. HPM6LS3DBBHHP: 316 Stainless steel construction with double isolate 10mm bore ball valves, PTFE packing, PEEK seats. Single bleed/vent valve globe pattern needle, none rotating self-centering tip, T bar handle, PTFE packing and metal/metal seat. Process and instrument connection 1/2" NPT female, bleed/vent 1/4" NPT female. Maximum cold working pressure 10,000 psig (689 barg).

Series HPM6L*3DBBB

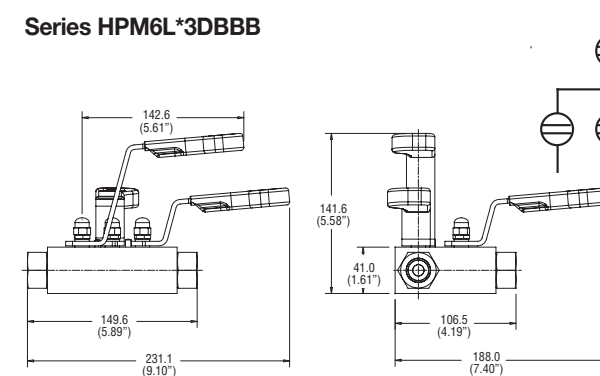

Standard Product Specifications

Part No. HPM6LS3DBBB: 316 Stainless steel construction with double isolate and vent/bleed 10mm bore ball valves, PTFE packing, PTFE seats. Process and instrument connection 1/2" NPT female, bleed/vent 1/4" NPT female. Maximum cold working pressure 6,000 psig (414 barg).

Part No. HPM6LS3DBBBHHP: 316 Stainless steel construction with double isolate and vent/bleed 10mm bore ball valves, PTFE packing, PEEK seats. Process and instrument connection 1/2" NPT female, bleed/vent 1/4" NPT female. Maximum cold working pressure 10,000 psig (689 barg).

9

Hi-Pro Manifolds

Available options

Suffix adding sequence	Function	Option Detail	All Valves	Ball	Needle	Body
1	Gland packing	Graphite (all valves)	3	-	-	-
2	Seating	PEEK	-	PKB	PKN	-
3	Plug/Bleed valve	Blank plug 1/2 NPT	P	-	-	-
	(supplied loose in box)	Bleed valve	BV	-	-	-
		Plug & bleed valve	PBV	-	-	-
4	Connection style	Socket weld extension	-	-	-	SW*NBM
Note 1		Socket weld	-	-	-	SW*NB
		Butt weld	-	-	-	BW*NB
		BSPT	-	-	-	*K
		BSPP	-	-	-	*R
Note 2		A-LOK®/CPI™	-	-	-	See note 2
		Secured end connector	-	-	-	LC
5	Operating mechanism	Spanner actuation	-	SA*	-	-
Note 3		Anti tamper T bar	-	-	AT*	-
		Anti tamper + key	-	-	ATK*	-
		Hand wheel	-	-	HW*	-
		Lockable hand wheel	-	-	LHW*	-
		Lockable handle	-	HL*	THL*	-
6	Mounting	Mounting holes	-	-	-	MH
Note 4		Assembled to bracket	-	-	-	BRK
7	Condition	NACE	NACE	-	-	-
Note 5		Cleaned and lubricated for oxygen use	OXY	-	-	-
		Fire safe	FS	-	-	-
		Fire safe certified	FC	-	-	-
		Heat Code Certs.	HCT	-	-	-

Note 1: For tube or pipe sizing use denominations of 1/16" i.e. 8 = 1/2". Give actual size for metric i.e. M12. For tube socket weld change NB to TB.

Note 2: For A-LOK®/CPI™ use 1/16" denominations i.e. 1/2"=8A. For metric use actual size i.e. 12mm = M12A. For CPI™ change A to Z. To specify inlet e.g. 1/2" A-LOK® suffix part number E8A and for outlet X8A.

Note 3: *Indicate which valve requires locking feature i.e. 1 = Primary, 2 = Secondary, 3 = Vent/drain, 4 = All valves.

Note 4: Bracket will include U bolt and manifold/bracket bolts.

Note 5: Certification requirements should be clearly requested at enquiry and order stage - we are unable to provide retrospectively.

Material	*Insert
316 Stainless steel std	S
Monel	M
Duplex	D1
Hasteloy	HC
Carbon steel	C
6Mo	6MO
Inconel 625	625

10

Hi-Pro Manifolds

The widest range of precision Instrumentation products



11

Parker Worldwide

AE – UAE, Dubai
Tel: +971 4 8875600
parker.me@parker.com

AR – Argentina, Buenos Aires
Tel: +54 3327 44 4129

AT – Austria, Wiener Neustadt
Tel: +43 (0)2622 23501-0
parker.austria@parker.com

AT – Eastern Europe, Wiener Neustadt
Tel: +43 (0)2622 23501 970
parker.easteurope@parker.com

AU – Australia, Castle Hill
Tel: +61 (0)2-9634 7777

AZ – Azerbaijan, Baku
Tel: +994 50 2233 458
parker.azerbaijan@parker.com

BE/LX – Belgium, Nivelles
Tel: +32 (0)67 280 900
parker.belgium@parker.com

BR – Brazil, Cachoeirinha RS
Tel: +55 51 3470 9144

BY – Belarus, Minsk
Tel: +375 17 209 9399
parker.belarus@parker.com

CA – Canada, Grimsby, Ontario
Tel: +1 905-945-2274
ipd_canada@parker.com

CH – Switzerland, Etoy
Tel: +41 (0) 21 821 02 30
parker.switzerland@parker.com

CN – China, Shanghai
Tel: +86 21 5031 2525

CZ – Czech Republic, Klecany
Tel: +420 284 083 111
parker.czechrepublic@parker.com

DE – Germany, Kaarst
Tel: +49 (0)2131 4016 0
parker.germany@parker.com

DK – Denmark, Ballerup
Tel: +45 43 56 04 00
parker.denmark@parker.com

ES – Spain, Madrid
Tel: +34 902 33 00 01
parker.spain@parker.com

FI – Finland, Vantaa
Tel: +358 (0)20 753 2500
parker.finland@parker.com

FR – France, Contamine s/Arve
Tel: +33 (0)4 50 25 80 25
parker.france@parker.com

GR – Greece, Athens
Tel: +30 210 933 6450
parker.greece@parker.com

HK – Hong Kong
Tel: +852 2428 8008

HU – Hungary, Budapest
Tel: +36 1 220 4155
parker.hungary@parker.com

IE – Ireland, Dublin
Tel: +353 (0)1 466 6370
parker.ireland@parker.com

IN – India, Mumbai
Tel: +91 22 6513 7081-85

IT – Italy, Corsico (MI)
Tel: +39 02 45 19 21
parker.italy@parker.com

JP – Japan, Fujisawa
Tel: +(81) 4 6635 3050

KR – South Korea, Seoul
Tel: +82 2 559 0400

KZ – Kazakhstan, Almaty
Tel: +7 7272 505 800
parker.easteurope@parker.com

LV – Latvia, Riga
Tel: +371 6 745 2601
parker.latvia@parker.com

MX – Mexico, Apodaca
Tel: +52 81 8156 6000

MY – Malaysia, Shah Alam
Tel: +603-78490800

NL – The Netherlands, Oldenzaal
Tel: +31 (0)541 585 000
parker.nl@parker.com

NO – Norway, Stavanger
Tel: +47 (0)51 826 300
parker.norway@parker.com

NZ – New Zealand, Mt Wellington
Tel: +64 9 574 1744

PL – Poland, Warsaw
Tel: +48 (0)22 573 24 00
parker.poland@parker.com

PT – Portugal, Leca da Palmeira
Tel: +351 22 999 7360
parker.portugal@parker.com

RO – Romania, Bucharest
Tel: +40 21 252 1382
parker.romania@parker.com

RU – Russia, Moscow
Tel: +7 495 645-2156
parker.russia@parker.com

SE – Sweden, Spånga
Tel: +46 (0)8 59 79 50 00
parker.sweden@parker.com

SG – Singapore,
Tel: +65 6887 6300

SK – Slovakia, Banská Bystrica
Tel: +421 484 162 252
parker.slovakia@parker.com

SL – Slovenia, Novo Mesto
Tel: +386 7 337 6650
parker.slovenia@parker.com

TH – Thailand, Bangkok
Tel: +662 717 8140

TR – Turkey, Istanbul
Tel: +90 216 4997081
parker.turkey@parker.com

TW – Taiwan, Taipei
Tel: +886 2 2298 8987

UA – Ukraine, Kiev
Tel: +380 44 494 2731
parker.ukraine@parker.com

UK – United Kingdom, Barnstaple
Tel: +44 (0)1271 313131
parker.uk@parker.com

US – USA, Cleveland
Tel: +1 216 896 3000

VE – Venezuela, Caracas
Tel: +58 212 238 5422

ZA – South Africa, Kempton Park
Tel: +27 (0)11 961 0700
parker.southafrica@parker.com

European Product Information Centre
Free phone: 00 800 27 27 5374
(from AT, BE, CH, CZ, DE, DK, EE, EI, ES, FI,
FR, IT, NL, NO, PL, RU, SE, SK, UK, ZA)

© 2008 Parker Hannifin Corporation. All rights reserved



Parker Hannifin Ltd
**Instrumentation Products
Division Europe,**
Riverside Road,
Pottington Business Park,
Barnstaple, Devon, EX31 1NP
United Kingdom
Tel.: +44 (0) 1271 313131
Fax: +44 (0) 1271 373636
www.parker.com/ipd

Parker Hannifin Corporation
Instrumentation Products Division
1005 A Cleaner Way
Huntsville, AL 35805
Tel: + 1 (256) 881-2040
Fax: + 1 (256) 881-5072
www.parker.com/ipdus

Catalogue 4190-HBM