



# Process Analytical Guide: Valves, Regulators and Systems

Catalog 4255-PA

August 2023

aerospace  
climate control  
electromechanical  
filtration  
fluid & gas handling  
hydraulics  
pneumatics  
process control  
sealing & shielding



ENGINEERING YOUR SUCCESS.

Appendix

## Parker Instrumentation Products Division: Analytical Products Guide

Process analytics require precise control of key parameters such as pressure, flow and temperature. Operational control requires providing a reliable sample to the analyzer and subsequent data for optimum system control. Key control areas for process analytical applications such as sample extraction, sample conditioning, and sample return to process or site removal systems, are optimized by use of Parker Instrumentation Products Division (IPD) analytical products found within this catalog. Our products are designed to meet the demanding requirements of critical process applications and are used for sample isolation, stream selection, analyzer calibration, pressure regulation, flow and temperature control in liquid and gas systems.

For stream selection applications the Parker R-Max II™ and T-Max™ valve series provide process analytical customers unique flexibility in valve functionality while also providing an enhanced maintenance support platform. The R-Max II™ valve series is a robust surface mount platform that gives the customer full valve control using normally closed, normally open, GC module, Diverter module, Internal fast loop, filtration or single 3-way functionality options.

Within the Parker IPD analytical product suite you will find pressure regulation hardware designed utilizing ultra-high purity platform standards that have been applied to industrial and process analytical market applications. This base design provides superior pressure control while enhancing the ease of maintenance for long term operation. From single stage pressure regulation to multi-gas cylinder switching capabilities, the regulator products from IPD will provide the control and reliability required for process analytics.

The pressure control platform is supported by system-based pressure control and delivery products such as the Parker Vent Master™ and Vent Recovery Panel. The Vent Master™ allows the end user to have extremely consistent pressure control while enhancing sample removal to site disposal systems. The vent recovery panel is for single analyzer pressure control and is used for precise pressure control at low flow and minimal system back pressure.

Whether you need stream selection valves or precise pressure control, the Parker suite of analytical products will provide the control necessary for demanding process analytical environments and applications.

## Table of Contents

<b>STREAM SELECTION</b>	
R-Max™ II .....	5
T-Max™ (TSV) .....	30
<b>VALVES</b>	
NOVA/NOVA AOP Series.....	32
NV17 Series.....	37
NV55 Series.....	40
NV70 Series.....	43
FS190 Series .....	46
VR7 Series.....	48
<b>PRESSURE REGULATORS</b>	
IR4000 Series .....	51
IR5000 Series .....	54
IR6000 Series .....	57
ABP1 Series.....	60
ABP3 Series.....	63
BPR50 Series .....	66
AVR3 Series.....	69
AVR4 Series.....	72
APR66 Series.....	75
HPR800 Series .....	78
<b>SPECIALTY REGULATORS</b>	
HFR900 Series.....	79
735 Series.....	84
NPR4100 Series .....	87
SC423XL Series.....	90
<b>PRESSURE CONTROL SYSTEMS</b>	
COSE System .....	93
COSM System .....	94
Vent Master™ Systems .....	99
Analyzer Pressure Regulation & Vent Recovery System .....	124
<b>SAMPLE SYSTEMS</b>	
Intraflow™ .....	127
Intraflow™ Enhanced Functionalities .....	138
<b>Appendix</b>	
Schematics .....	145



# Gen II R-max™ Stream Switching System

Switching • Filtering • Gasses • Liquids



Stream  
Selection

## Value Proposition:

The Parker Gen II R-max™ is a multi-functional system capable of integrating both stream switching and filtering into one unique compact assembly. The system is designed to control both gases and liquids in analytical systems ranging from vacuum to 500 psig (34 bar) while requiring only 65 psig (5 bar) actuating air pressure. The system was engineered with a focus on improved product reliability and reduced cost of ownership. The Parker Gen II R-max™ Stream Switching System utilizes state-of-the-art surface mount technology to reduce leak paths, internal volume, and dead volume. With surface mounting, system components may be easily removed and replaced without breaking process connections. In addition, the Parker Gen II R-max™ system utilizes an internal self-purging outlet header .

## Product Features:

- **Modular valve design** offers **maximum** serviceability for quick and easy in-system repair, reduced downtime and can be utilized for valve module check procedures.
- **Low internal volume** insures **maximum** system efficiency by reducing purge time and expensive purge gas.
- **Enhanced position indicator** enables easy recognition of valve position for **maximum** system safety.
- **Captured vent** provides a low pressure header that separates sample stream from actuation air preventing cross contamination.
- **Backward compatibility** allows the enhanced features to be added to existing units.
- **Surface mount technology** enhances **maximum** system flexibility and enables the user to add additional streams to a system without interrupting installed units.
- The Gen II R-max™ is available for **ANSI/ISA-76.00.02 (NeSSI) mounting. US Patent 6619321**
- Maximum Application Flexibility is achieved by utilizing multiple available valve functions within a single assembly

# Gen II R-max™

## Specifications:

Stream Selection

Functional Performance	
<b>Pressure Rating</b>	500 psig (34 bar) CWP
<b>Temperature Rating</b>	Fluorocarbon Rubber: -15°F to 400°F (-26°C to 204°C) Buna-N Rubber: -30°F to 275°F (-34°C to 135°C) Ethylene Propylene Rubber: -70°F to 275°F (-57°C to 135°C) Neoprene Rubber: -45°F to 250°F (-43°C to 121°C) Highly Fluorinated Fluorocarbon Rubber: -25°F to 300°F (-32°C to 150°C)
<b>Flow Data</b>	Stream 1: $C_V = 0.154$ Stream 2: $C_V = 0.104$

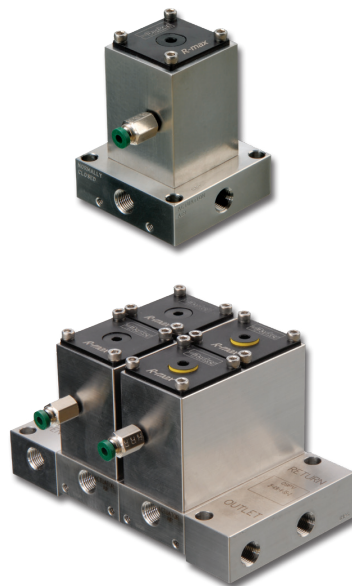

## Actuation Pressure vs. System Pressure:

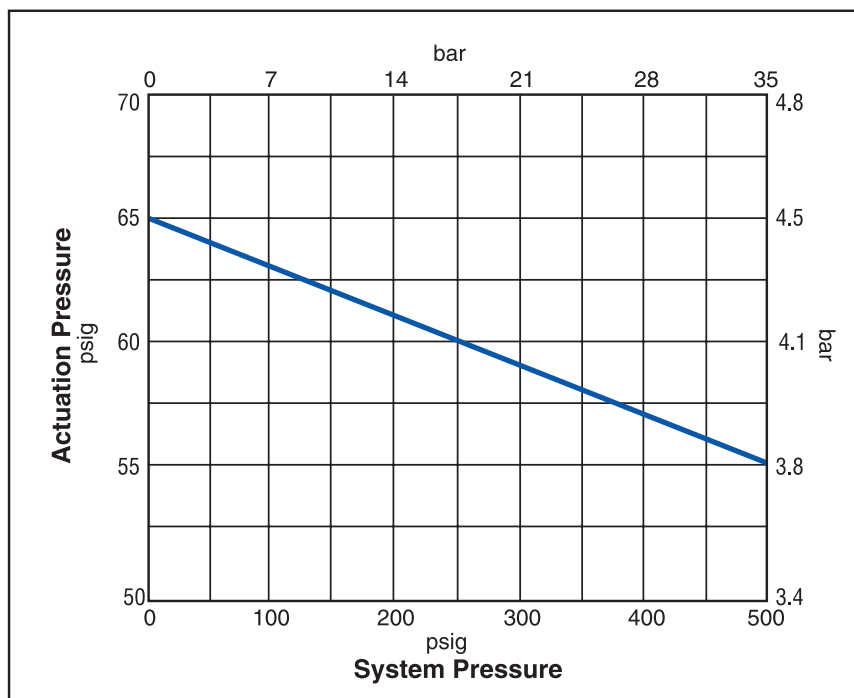

# Gen II R-max™

## Exterior Dimensions:

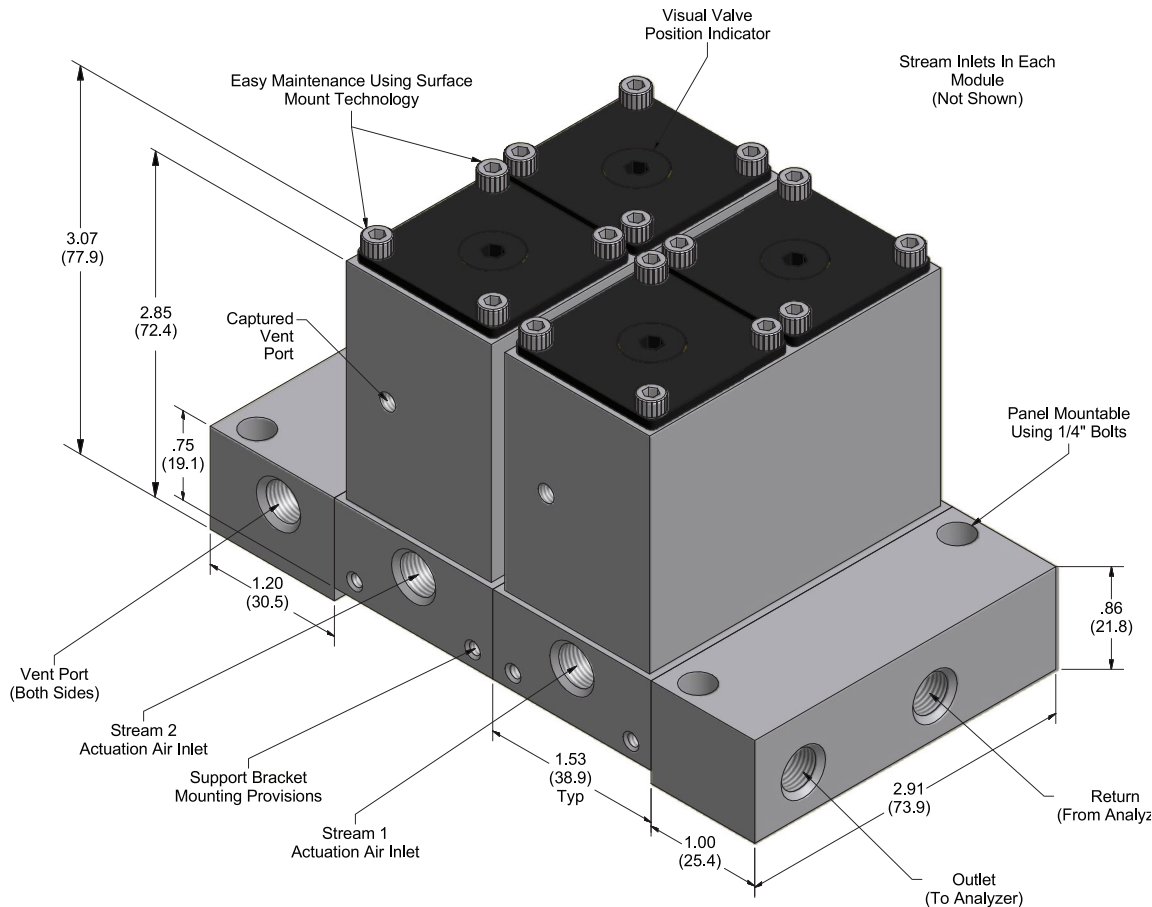

Stream Selection

## Available End Connections:

**4A7** - 1/4" inverted two ferrule A-LOK® compression port

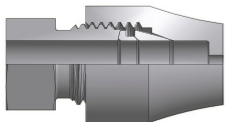

**4Z7** - 1/4" inverted single ferrule CPI™ compression port

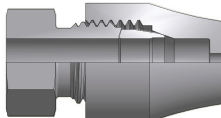

**2F** - 1/8" ANSI/ASME B1.20.1 internal pipe threads

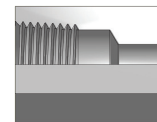

**Note:** Actuator air porting and vent porting is always 1/8" FNPT.

# Gen II R-max™

## Valve Module Exploded View:

Stream Selection

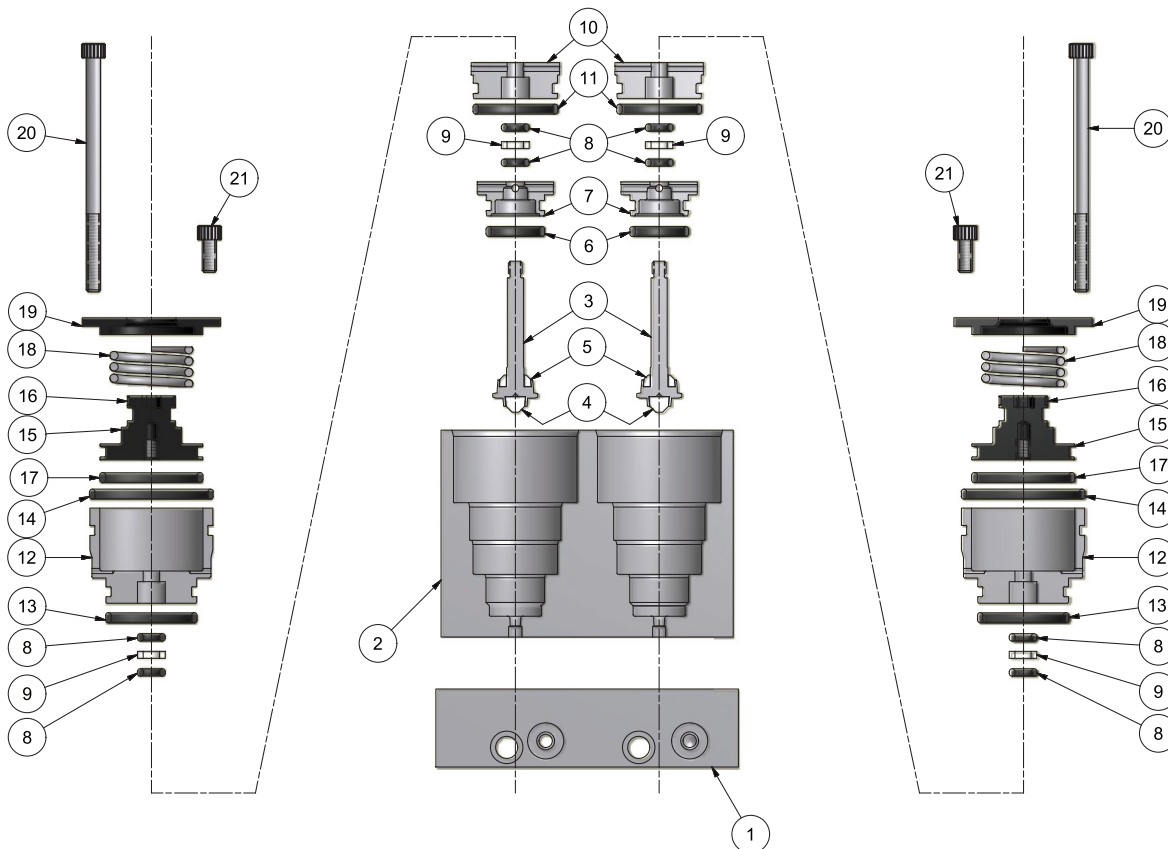

## Material of Construction:

Item	Part Description	Material
1	Base	ASTM A 479, type 316
2	Valve Body	ASTM A 479, type 316
3	Stem	ASTM A 479, type 316
4	Seat	PCTFE
5	Backseat	PCTFE
6	2-013 O-Ring	Optional elastomers
7	Lower Bonnet	ASTM A 479, type 316
8	2-007 O-Ring	Optional elastomers
9	Backup Ring	PTFE
10	Center Bonnet	ASTM A 479, type 316
11	2-017 O-Ring	Optional elastomers

Item	Part Description	Material
12	Upper Bonnet	ASTM A 479, type 316
13	2-018 O-Ring	Optional elastomers
14	2-023 O-Ring	Optional elastomers
15	Piston	ASTM B 611, Alloy 6061
16	Indicator	Flexible polyolefin
17	2-020 O-Ring	Optional elastomers
18	Spring	ASTM A 546, type 630
19	Cap	ASTM B 211, Alloy 6061
20	Bolt (6-32 x 2.25)	Stainless steel
21	Bolt (6-32 x 5/16)	Stainless steel

**Note:** Material for Stream Switching Vent and Analyzer End Plates (not shown) is ASTM A 479, type 316.  
Material for Base Plate Bolts is ASTM A 276, type 316.

Lubrication: Perfluorinated polyether

# Gen II R-max™

## Valve Module:

The Parker Gen II R-max™ Stream Switching System centers around the Valve Module, which contains two 3-way valves. Each Valve Module is factory mounted to a base plate configured to provide the desired function. The Stream Switching Valve Module provides a double block and bleed arrangement preventing cross contamination of the sample streams.

## Valve Module Features:

- Each Valve Module has a flow inlet (1/8" FNPT or 1/4" Inverted Compression) and a 1/8" FNPT valve air actuation port.
- Each Valve Module employs two valves.

## Valve Module Flow Diagram:

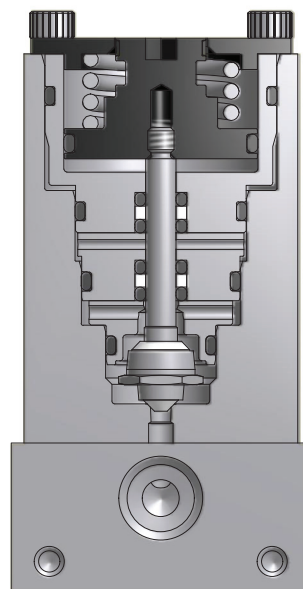
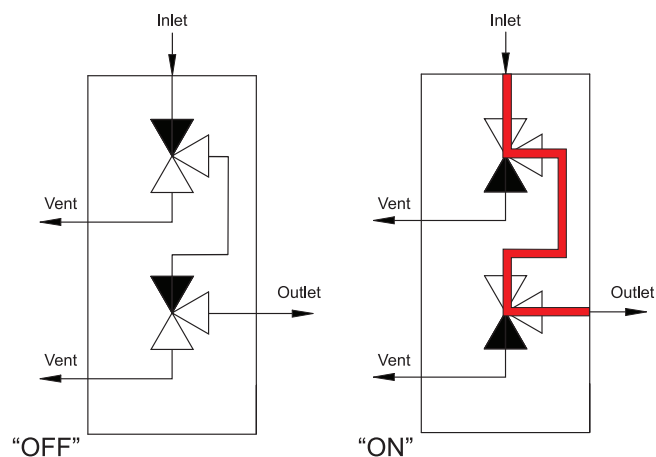

Stream Selection

## Valve Expansion Module - R3EM

Valve Expansion Modules may be added or removed from the Parker Gen II R-max™ Stream Switching System. The Valve Expansion Module consists of a Valve Module plus two base plate bolts. They may be inserted between the vent and analyzer end plates to add one or more streams to a system. (See How to Order on pages 12-14.)

**Note:** Valve Modules may only be added to an existing stream switching system.

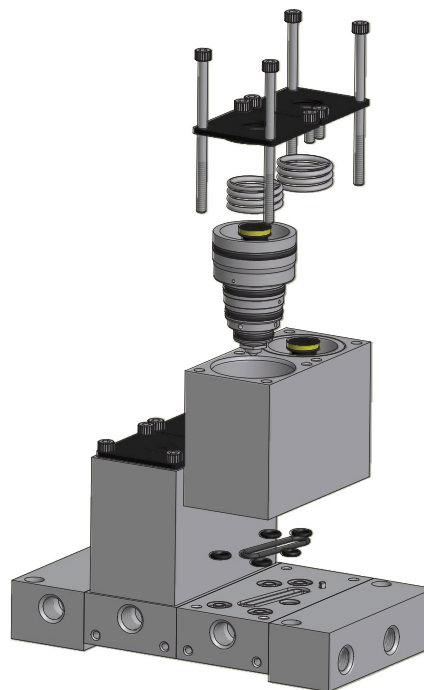

# Gen II R-max™

## Captured Vent

The Parker Gen II R-max™ is designed with a captured vent header which isolates the sample stream from the actuation air preventing cross contamination. The Captured Vent has 10-32 threads which allows the captured vent to be directed to a containment device.

Porting options include fittings for use with:

- 1/8" plastic tubing
- 1/8" SS tubing
- 1/8" pipe
- 10-32 plug

Stream Selection

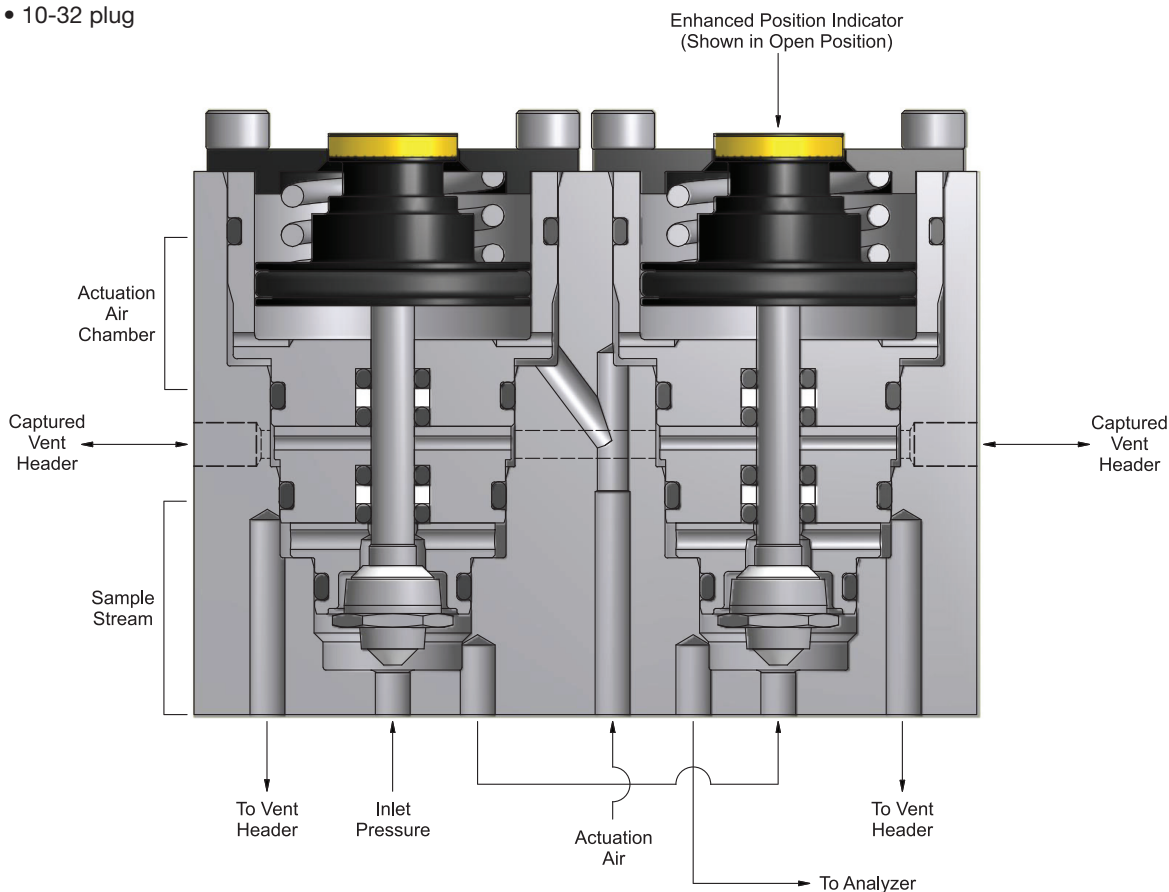

## Enhanced Position Indicator

The Parker Gen II R-max™ is designed with an enhanced position indicator. The cap and piston are black anodized aluminum. The visual indicator, when actuated open, shows bright yellow against the black background giving easy indication for the open stream.

The visual indicator is also backwards compatible with the R2 Series R-max™ Stream Select System. Any R-max™ Stream Select Systems in service can easily be retrofitted with the enhanced indication.

# Gen II R-max™

## Multi-Stream Switch -R3:

A Multi-Stream Switch consists of individual Valve Modules bolted together between vent and analyzer end plates to create an internal, self-purging system with an integral outlet header. This unique design eliminates dead volume and the need for an external loop.

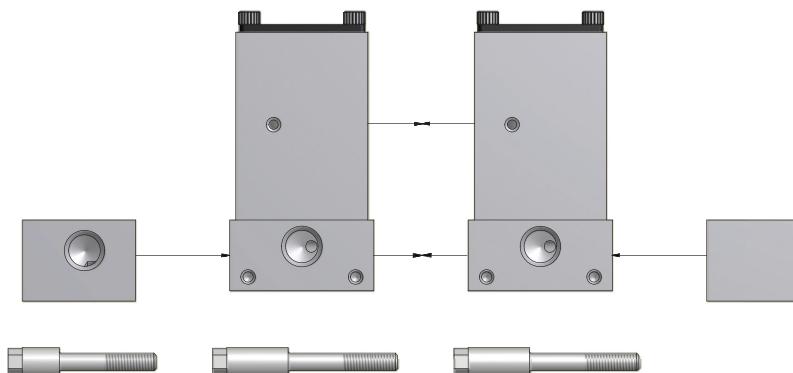

Stream Selection

## Fast Loop Options:

### Internal Fast Loop

Example shown is a three stream switching system with an internal fast loop that maintains the double block and bleed feature. Illustrates Streams 1 and 3 in the “off” position, with these two streams flowing to the common vent. Stream 2 is illustrated in the “on” position, closing the bypass and directing the flow to the analyzer. To order, add the suffix **-IF** to the end of the Stream Switching System part number. (How to Order; see pages 12-14.)

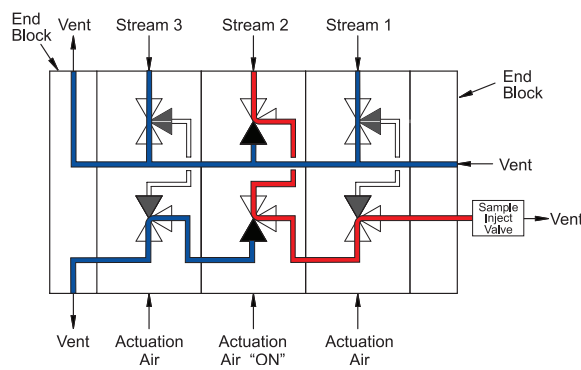

**Example: 2F-R3K-BN-SS-3-IF**

### Sample Bypass Filters

Example shown is a three stream switching system with two filter bypasses. Bypass Filter Kits may be incorporated into the Parker Gen II R-max™ Stream Switching System to enhance your system design. (How to Order; see pages 12-14 and 22-23.)

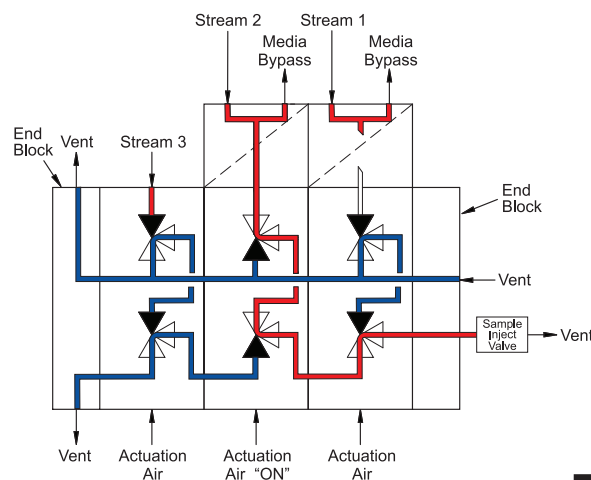

# Gen II R-max™

## Atmospheric Reference Vent (ARV) Module

The Atmospheric Reference Vent Module provides many advantages and benefits within a modular footprint. It can be installed inline with existing Stream Switching Modules or act as a stand alone unit.

When the ARV Module is positioned between the analyzer and stream switching units it allows for sample shut-off and equilibration of the sample loop pressure to atmosphere. This insures a consistent sample volume in repetitive analysis. When the ARV Module is actuated, the sample flows from the actuated (open) stream, through the GC analyzer and is routed to the low pressure header.

The improved features on the Stream Switching Units are included on the ARV Modules. This includes the Captured Vent and Enhanced Position Indicator. It is provided with a new end block which has a dedicated atmosphere reference port. Also, the re-designed ARV Modules can be used with Fast Loop Filtration.

Stream Selection

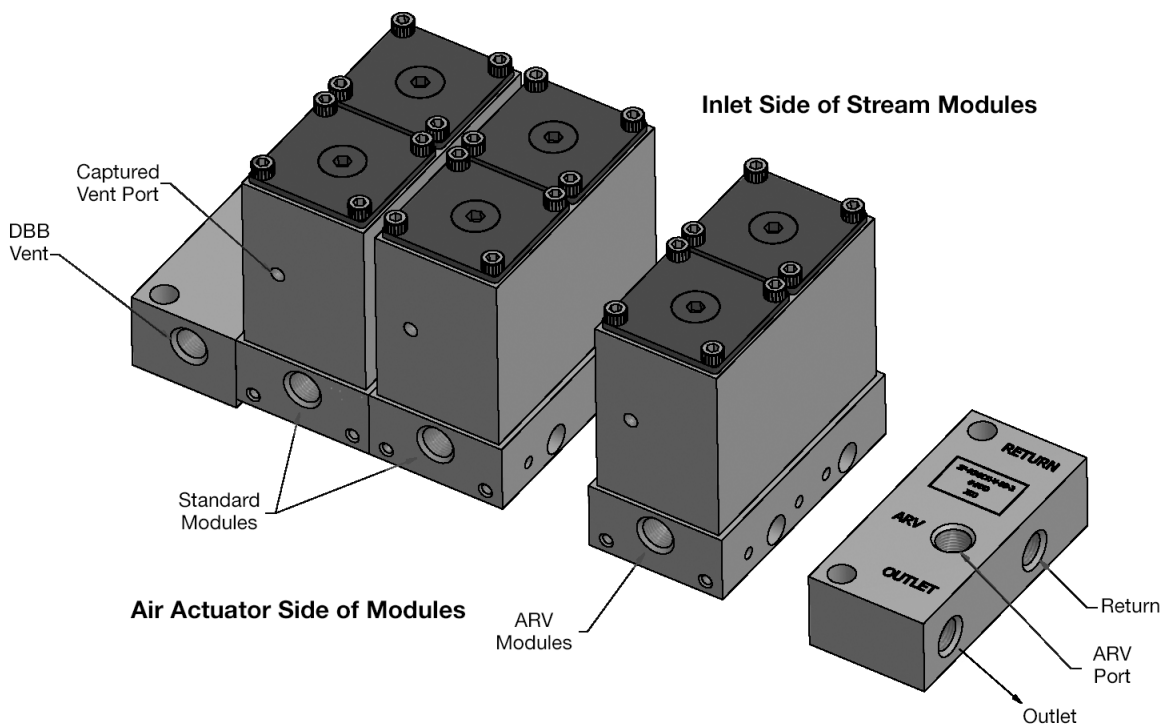

# Gen II R-max™

## Stream Switch with ARV Module Function - Three Stream Examples

### Example 1

All valves are in the “off” position. The system is “open” to vent.

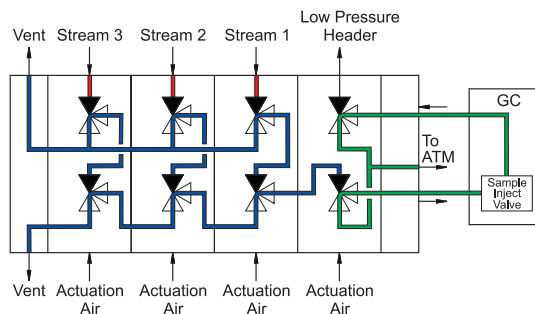

### Example 2

Stream 2 and the ARV Module are in the “on” position, purging the sample loop to the low pressure header.

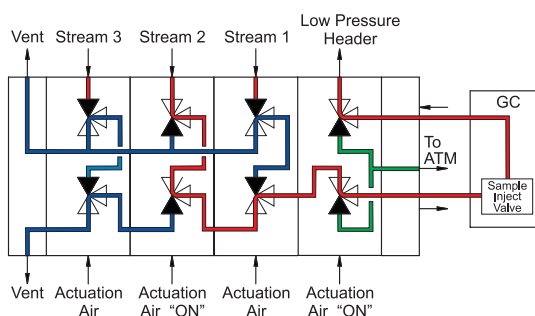

### Example 3

Stream 2 is in the “on” position and the ARV Module is in the “off” position, equilibrating the sample loop pressure to vent pressure.

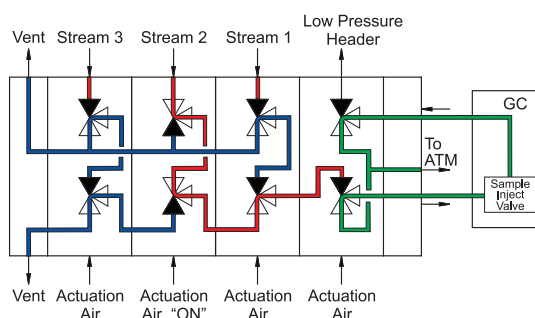

Stream Selection

## Backward Compatibility Features:

Aspects of the R3 Series Gen II R-max™ can be applied for use with existing R2 Series units.

**Valve Bodies:** The valve bodies are maintained using four 6-32 bolts. Removing these allows the existing R2 Series Body to be removed and the new R3 Series Body to be installed with new 6-32 bolts.

Example for Valve Body Kit: **KIT-R3K-BODY-\*\*-SS**

**Position Indicator:** The Enhanced Position Indicator used on the R3 Series Gen II R-max™ provides a yellow indicator that is easily identifiable against a black background. This Indicator can be fitted onto the R2 Series R-max™ for the same easy identification of valve position. Example for Position Indicator Kit: **KIT-R3-EPI-\*\*-SS**

**Redesigned ARV (Atmospheric Reference Vent) Option:** R2 Series Stream Select Units can be installed with the redesigned ARV End Plate. **Note**, this also requires a special stream select module to block the ARV Port from the Vent Port. Example: **KIT-R3GCK-Retrofit-\*\*-SS**

\*\* designated elastomer selection required: V, KZ, BN, etc.

# Gen II R-max™

## How to Order Stream Switching Systems and Accessories

The correct part number is easily derived by following the sequence shown below. The eight product characteristics required are coded as shown below.



Example: **2F - R3 - K - V - SS - 2 - A E**

The example above describes a two stream switching system having 1/8" female NPT inlet and outlet ports, PCTFE valve seats, fluorocarbon rubber seals, stainless steel construction, a fitting for 1/8" plastic tubing on the captured vent port (inlet side) and a 10-32 plug on the other captured vent port.

Stream Selection

End Connection <sup>(1)</sup>	Valve Series	Base Options <sup>(2)</sup>	Seat Material	Seal Material	Body Material <sup>(3)</sup>	Number of Modules	Captured Vent Fittings <sup>(4)</sup>
<b>2F</b> <b>4A7</b> <b>4Z7</b>	<b>R3</b>	<b>Blank</b> None <b>GC</b> ARV Module <b>EM</b> Valve Expansion Module <b>NO</b> Normally Open	<b>K</b> PCTFE <b>PK</b> Virgin PEEK <b>VE</b> Vespel	<b>V</b> Fluorocarbon Rubber <b>BN</b> Buna-N Rubber <b>EPR</b> Ethylene Propylene Rubber <b>NE</b> Neoprene Rubber <b>KZ</b> Highly Fluorinated Fluorocarbon Rubber	<b>SS</b> Stainless Steel	<b>Numeric value</b> <b>Blank</b> <b>EM</b> Base Options	<b>A</b> 1/8" plastic tubing <b>B</b> 1/8" CPI™ compression <b>C</b> 1/8" A-LOK® compression <b>D</b> 1/8" FNPT <b>E</b> 10-32 plug <b>F</b> No fitting

<sup>(1)</sup> See page 3.

<sup>(2)</sup> The expansion module (EM) option allows for adding additional modules to existing stream switching units. A sample part number for an ARV expansion module is 2F-R3EMK-V-SS-ARV-FF. When adding an ARV expansion module, the base to the adjoining module must be changed for proper function.

<sup>(3)</sup> Contact Customer Service for availability of exotic alloys such as Monel® and Hastelloy®.

<sup>(4)</sup> In the part numbering scheme, the first captured vent letter designator is for the inlet side of the R-max™ Module. All captured vent fittings have a 10-32 thread for assembly into the valve body.

## How to Order Additional Options

**Oxygen Cleaning:** Add the suffix **-C3** to the end of the part number to receive stream switching systems or accessories cleaned and assembled for oxygen service in accordance with Parker specification ES8003.

Add the suffix **-RTK** to the end of the part number to receive stream switching systems or accessories coated with the inert, silicon-based chemical coating Silconert™ 1000 (formerly Silcosteel®).

Add the suffix **-SUL** to the end of the part number to receive stream switching systems or accessories coated with the inert, silicon-based chemical coating Silconert™ 2000 (formerly Sulfinert®).

**NACE:** Add the suffix **-NC** to the end of the part number to receive stream switching systems or accessories that meet the material requirements of ANSI/NACE MR0175/ISO 15156-1.

**Internal Fast Loop:** Add the suffix **-IF** to the end of the part number to receive an internal fast loop on all modules. To designate a portion of the total number of modules contact Customer Service.

**Low Pressure Actuators:** Available factory assembled or as kits for field assembly. Refer to pages 13 and 14 for part number configuration.

# Gen II R-max™

## How to Order Kits

In using this section, the items in **BOLD CAPITALIZED PRINT** are included within the part number of the Kit. The italicized items require a designator to complete the part number. Refer to the How To Order section on page 14 for the designators.

**Stem Seal Kit:** Components required to rebuild the soft goods in one cartridge.

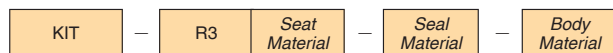

**Example:** **KIT** - **R3** *K* - *V* - **SS**

This example describes a kit consisting of one stainless steel stem with PCTFE upper and lower seats, fluorocarbon O-rings, associated PTFE back-up rings and maintenance instructions.

**Note:** This kit is also used for Single Valve Cartridge maintenance.

**Valve Module Kit:** Components required to rebuild the soft goods in one valve module. This includes the base and cartridges' seals.

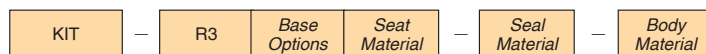

**Example:** **KIT** - **R3** **EM** **K** - **BN** - **SS**

This example describes a kit consisting of two stainless steel stems with PCTFE upper and lower seats, Buna-N O-rings, associated PTFE back-up rings and maintenance instructions.

**Note:** For kit part numbers, choose GC, NO and EM for the base option.

**Valve Cartridge Kit:** Components to replace one valve cartridge.



**Example:** **KIT** - **R3** **K** - **CART** - **EPR** - **SS**

This example describes a kit consisting of one completely assembled valve cartridge having PCTFE seats, ethylene propylene O-rings, stainless steel metallic components and maintenance instructions.

**Valve Body Kit:** Components required to replace one valve body assembly. This includes the cartridges.

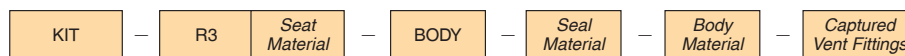

**Example:** **KIT** - **R3** **K** - **BODY** - **V** - **SS** - **FF**

This example describes a kit consisting of one complete valve body and cartridge assembly having PCTFE seats, fluorocarbon O-rings, stainless steel metallic components and maintenance instructions.

**Note:** The springs, screws and caps are included, but not assembled.

Kits continued on the following page.

# Gen II R-max™

## How to Order Kits (continued)

**Base Seal Kit:** Components to replace the soft goods in one base.



**Example:** KIT - R3 EM - BASE - SEALS - KZ

This example describes a kit consisting of highly fluorinated fluorocarbon O-rings and maintenance instructions.

**Note:** For the base option, include NO for normally open or GC for ARV options.

Stream Selection

**End Block Seal Kit:** Components to replace the soft goods in one end block.



**Example:** KIT - R3 - END - SEALS - V

This example describes a kit consisting of fluorocarbon O-rings and maintenance instructions.

**Note:** For the end block option, choose GC for ARV end blocks.

**Position Indication Kit:** The R3 Series Gen II R-max™ Position Indicator is backwards compatible to R2 Series R-max™ Units. Simply remove the piston and cap from an existing R2 Series Cartridge and replace with the R3 Series piston and cap. Functionality and performance will remain the same but will include enhance visual awareness of when the unit is actuated open.



**Example:** KIT - R3 - EPI - V

This example describes a kit consisting of enhanced visual indicator piston and cap, fluorocarbon O-ring and maintenance instructions.

**Captured Vent Fitting Kit:** The R3 Series Gen II R-max™ Captured Vent Header features 10-32 threads on the side of each module. There is a variety of fittings available to direct fluid in this header to a containment device. These fittings can be ordered individually based upon the following part numbers:

Description	Part Number <sup>(1)</sup>
1/8" plastic tubing <sup>(2)</sup>	KIT-R3-CVF-2PLP
1/8" CPI™ compression	KIT-R3-CVF-2Z-V-SS
1/8" A-LOK® compression	KIT-R3-CVF-2A-V-SS
1/8" female NPT	KIT-R3-CVF-2F-V-SS
10-32 plug	KIT-R3-CVF-PLUG-V-SS

<sup>(1)</sup> For the elastomer option, choose V, BN, EPR, NE or KZ.

<sup>(2)</sup> This fitting is nickel-plated brass with a nitrile flat washer.

# Gen II R-max™

## Maintenance: Spare Parts and Rebuild Kits

Description	Part Number
Cartridge Kit	KIT-R3K-CART-**-SS- (SUL, RTK if required)
Valve Body Kit	KIT-R3K-BODY-**-SS- (SUL, RTK if required)
Valve Expansion Module Kit	2F-R3EMK-**-SS-++
Valve Expansion Module Kit #	2F-R3EMK-**-SS-ARV-++- (SUL,RTK if required)
Valve Base Seal Kit	KIT-R3EM-BASE-SEALS-**
Valve End Seal Kit	KIT-R3-END-SEALS-**
Single 3-Way Base Seal	KIT-R3S-BASE-SEALS-**
Single 3-Way Body Kit	KIT-R3SK-BODY-**-SS-++
Upgrading from R2 to R3 GC Module	KIT-R3GC-RETROFIT-**-SS

- \*\* Elastomer
- ++ Captured Vent Fitting
- # For valve base adjacent to GC Mobile

# Gen II R-max™

## Low Pressure Actuator

The Parker Gen II R-max™ Stream Switching System can be adapted to control both gases and liquids in analytical systems from vacuum to 500 psig while requiring only 35 psig actuating air pressure. The low pressure actuator assembly can be incorporated onto existing R-max™ Stream Switching Systems without affecting existing feature enhancements including the captured vent, enhanced visual indication or backwards compatibility.

Stream Selection

### Features

- 35 psig actuation air pressure
- Compatible with R-max™ and Gen II R-max™ units
- Factory installed or field retrofitable
- Backwards compatible
- Wide variety of elastomeric seals
- 316 stainless steel construction
- 100% factory tested

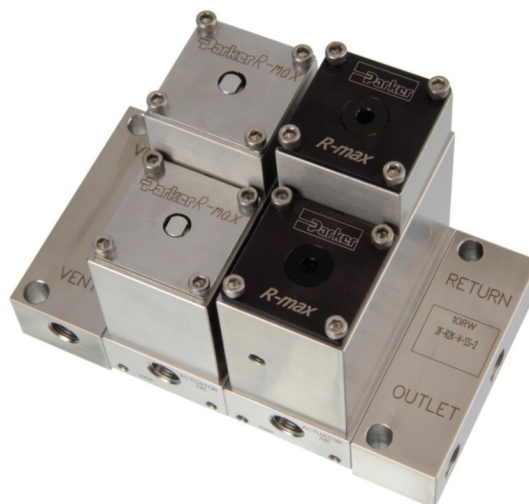

Actuation Pressure vs System Pressure

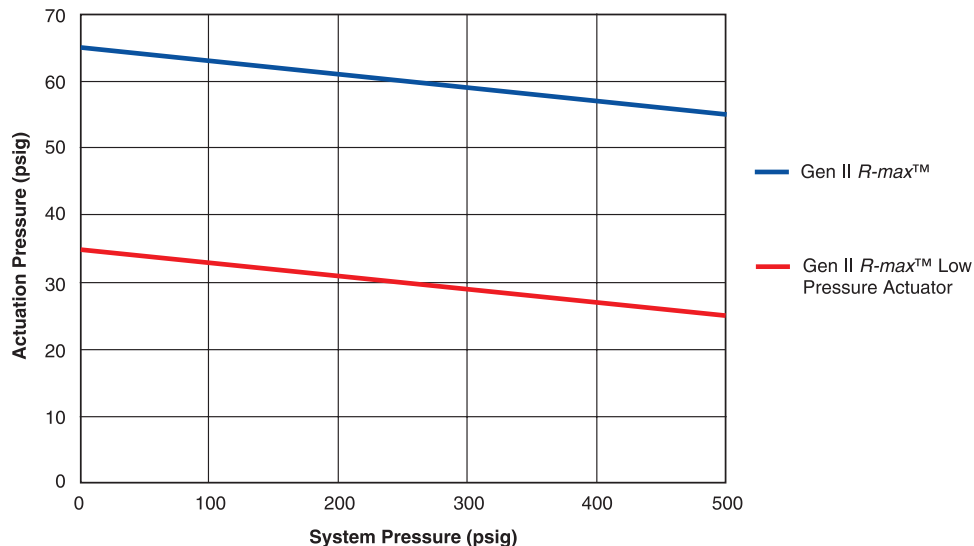

**Note:** The picture highlights the difference between the assembled low pressure actuator and a standard unit on first and second generation R-max™ valves. It is not recommended to use this actuator adapter on a single cartridge within a two cartridge module.

# Gen II R-max™

## Low Pressure Actuator

The Parker Gen II R-max™ Stream Switching System can be converted into a low pressure actuation unit with the addition of two components and associated seals. All other functional aspects of the R-max™ Stream Switching System remain the same.

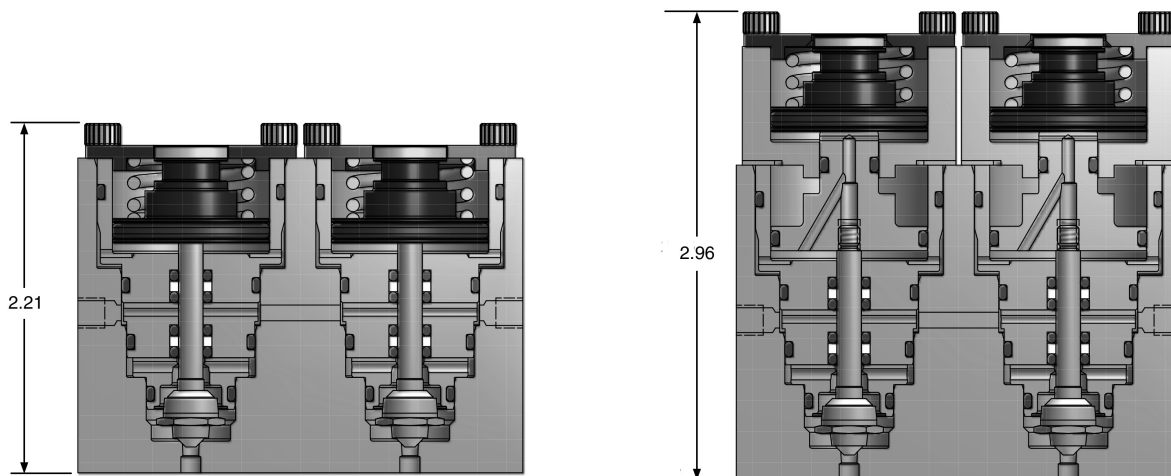

## How to Order Low Pressure Actuator

For a factory assembled and tested R-max™ Stream Switching Systems with the low pressure actuator add the suffix **-LP** to the end of the part number.

For example: **2F-R3K-KZ-SS-2-FF-LP**.

**Note:** See page 12 for Gen II R-max™ Stream Switching System part numbering.

For a kit to retrofit an existing unit, whether R-max™ or Gen II R-max™ Stream Switching System, use the following part numbers.

Description	Part Number <sup>(1)</sup>
For R-max™ Stream Switching System	KIT-R2LP-* <b>-SS</b>
For single R-max™ Stream Switching System	KIT-R2SLP-* <b>-SS</b>
For Gen II R-max™ Stream Switching System	KIT-R3LP-* <b>-SS</b>
For single Gen II R-max™ Stream Switching System	KIT-R3SLP-* <b>-SS</b>

\* Elastomeric options include fluorocarbon rubber (V), ethylene propylene rubber (EPR), buna-n (BN), neoprene (NE) or highly fluorinated fluorocarbon (KZ).

# Gen II R-max™

## Single Valve

The Parker Gen II R-max™ Single Valve shares the same technology, features, and options found in the Stream Switching System. The pneumatically actuated valve serves as a three-way diverting valve with common, normally open, and normally closed porting.

## External Dimensions

Stream Selection

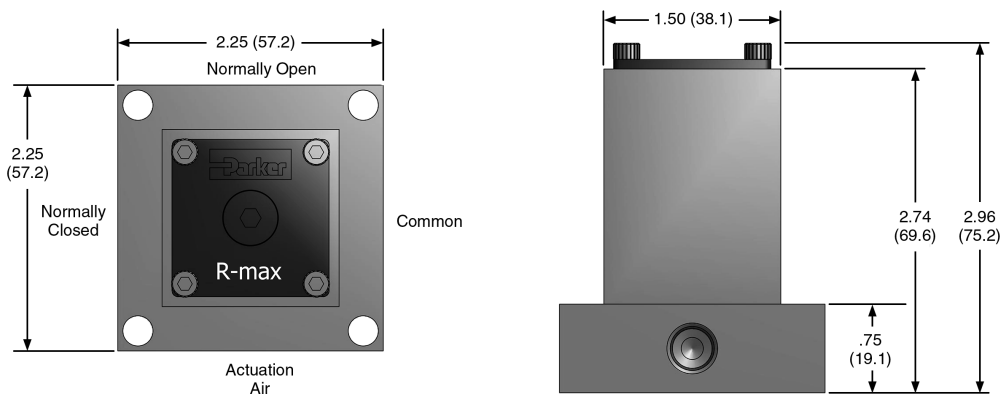

## Exploded View

The Single Valve shares similar components with the Double Block and Bleed Unit. With the exception of the Valve Body and Base, the components are identical and can be identified using the numbering system on page 6. Materials are identical and also can be identified on page 6.

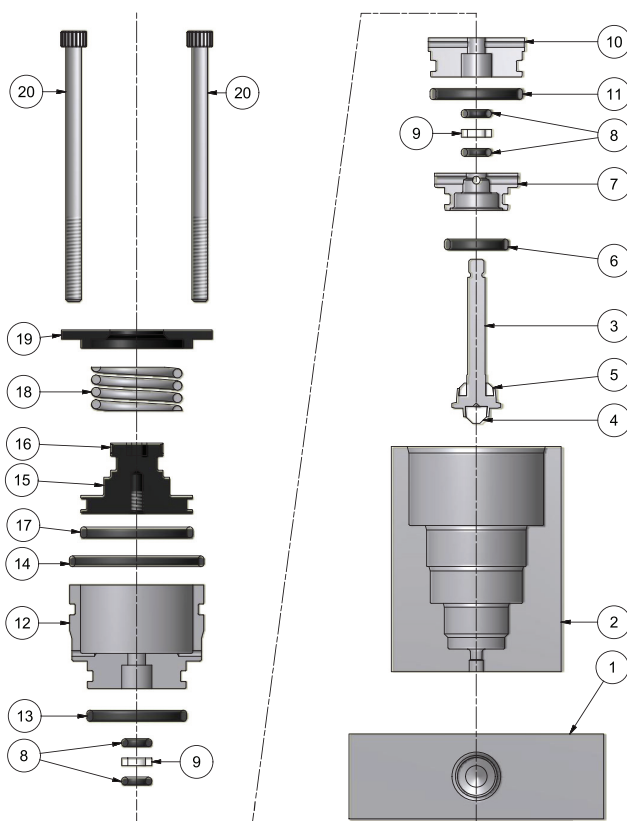

# Gen II R-max™

## How to Order - Single Valve

The correct part number is easily derived by following the sequence shown below. The six product characteristics required are coded as shown below.



**Example:** 2F - R3S K - V - SS - A

The example above describes a two stream switching system having 1/8" female NPT inlet and outlet ports, PCTFE valve seats, fluorocarbon rubber seals, stainless steel construction and fitting for 1/8" plastic tubing on the captured vent.

End Connection <sup>(1)</sup>	Valve Series	Seat Material	Seal Material	Body Material <sup>(3)</sup>	Captured Vent Fittings <sup>(4)</sup>
2F	R3S	K PCTFE	V Fluorocarbon Rubber	SS Stainless Steel	A 1/8" plastic tubing
4A7		PK Virgin PEEK	BN Buna-N Rubber		B 1/8" CPI™ compression
4Z7		VE Vespel	EPR Ethylene Propylene Rubber		C 1/8" A-LOK® compression
			NE Neoprene Rubber		D 1/8" FNPT
			KZ Highly Fluorinated Fluorocarbon Rubber		E 10-32 plug
					F No fitting

\* See page 3.

\*\* Contact Customer Service for availability of exotic alloys such as Monel® and Hastelloy®.

\*\*\* Only one captured vent fitting is required for the single valve. All fittings have a 10-32 thread for assembly into the valve body.

## How to Order Additional Options

**Oxygen Cleaning:** Add the suffix **-C3** to the end of the part number to receive stream switching systems or accessories cleaned and assembled for oxygen service in accordance with Parker specification ES8003.

Add the suffix **-RTK** to the end of the part number to receive stream switching systems or accessories coated with the inert, silicon-based chemical coating Silconert™ 1000 (formerly Silcosteel®).

Add the suffix **-SUL** to the end of the part number to receive stream switching systems or accessories coated with the inert, silicon-based chemical coating Silconert™ 2000 (formerly Sulfinert®).

**NACE:** Add the suffix **-NC** to the end of the part number to receive stream switching systems or accessories that meet the material requirements of ANSI/NACE MR0175/ISO 15156-1.

**Low Pressure Actuators:** Available factory assembled or as kits for field assembly. Refer to pages 13 and 14 for part number configuration.

# Gen II R-max™

## Fast loop Filters

Designed to be used on the stream inlet ports of the Parker Gen II R-max™ Stream Switching System. Multiple filtration options are available using technology developed and designed by Parker Filtration and Separation Divisions. Filtration options include particulate, coalescing and SS sintered.

The particulate filter is housed in a bypass filter that diverts approximately 90% of the inlet flow around the cartridge filter and provides fresh filtered media to the stream switch.

The coalescing filter allows liquid droplets to collect and drain from the media as it enters the stream switch.

The SS sintered filters are designed to protect the Stream Switching System from dirt, chips, scale and other contaminants.

Stream Selection

## Fast loop Filters

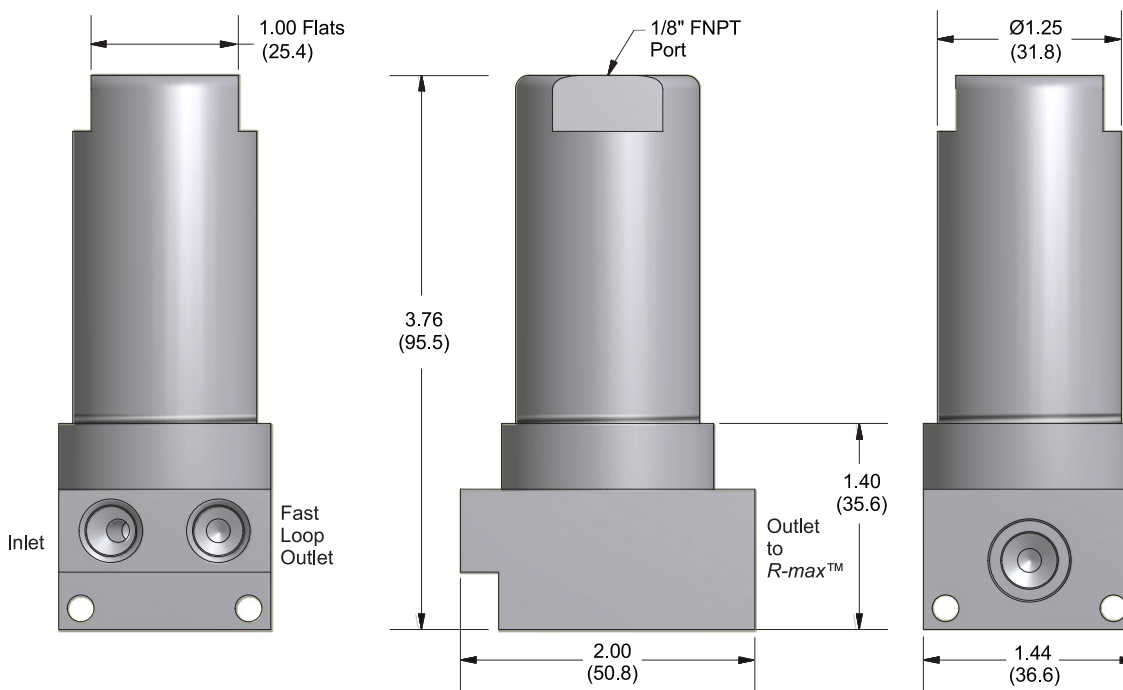

# Gen II R-max™

## Fast Loop Filters

Designed to bolt directly to the stream inlet ports of the Parker Gen II R-max™ Stream Switching System to provide reduced transport time of filtered sample stream media from the process line through the stream switch to the analyzer.

## Cross Section View

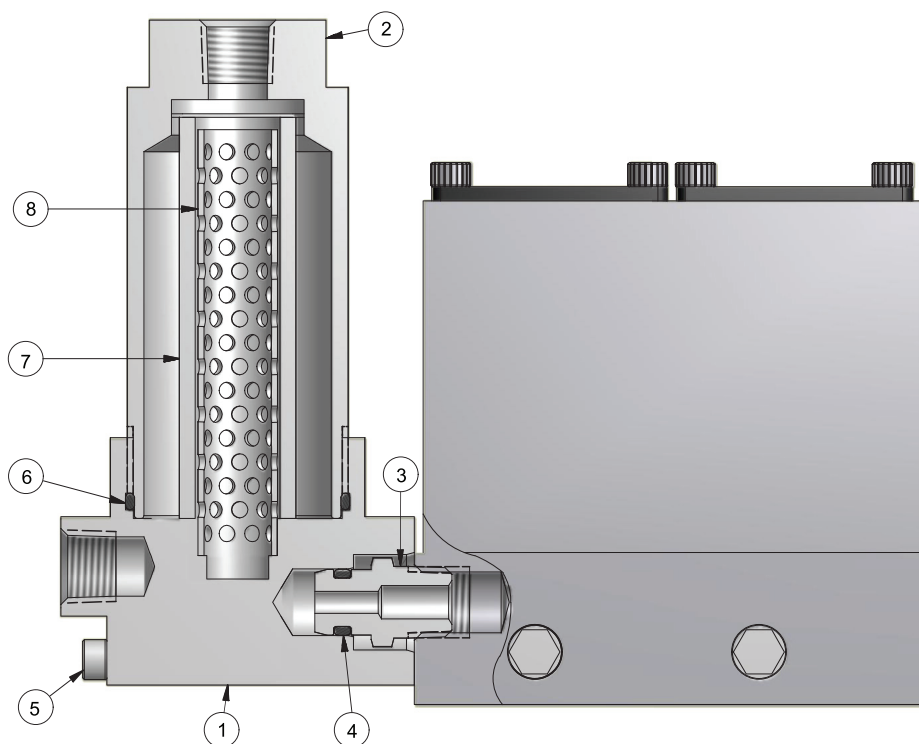

**Note:** The captured vent port nearest an assembled filter must be a plug or an open port.

## Materials of Construction

Item	Part Description	Material
1	Body	ASTM A 479, type 316
2	Bowl	ASTM A 479, type 316
3	Adapter	ASTM A 479, type 316
4	O-Ring 2-008	Optional elastomers
5	Body Bolt	Stainless steel
6	O-Ring 2-025	Optional elastomers
7	Element	316SS and Microfibre
8	Support Core	316SS

# Gen II R-max™

## How to Order - Fast Loop Filters

The correct part number is easily derived by following the sequence shown below. The seven product characteristics required are coded as shown below.

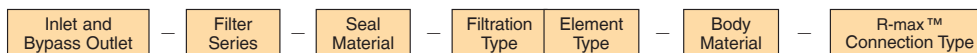

**Example: 2F - FR2 - EPR - S 100 - SS - B**

The example above describes an FR2 Series Fast Loop Filter with 1/8" FNPT inlet and bypass outlets, ethylene propylene rubber seals, 100 micron 316SS sintered metal filter element and stainless steel construction. It is designed to be attached to a Parker Gen II R-max™ Stream Switch having inverted CPI™ or A-LOK® stream inlet ports.

Stream Selection

Inlet and Bypass Outlet	Filter Series	Seal Material	Filtration Type	Element Type		Body Material	R-max™ Connection Type
				Balston® (P and C)	Sintered Metal (S)		
2F	FR2	V Fluorocarbon Rubber	P Particulate	93 93% microfibre	100 100 micron	SS Stainless Steel	A 2F B 4A7 or 4Z7
		BN Buna-N Rubber	C Coalescing	99 99% microfibre	70 70 micron		
		EPR Ethylene Propylene Rubber	S Sintered		40 40 micron		
		NE Neoprene Rubber			20 20 micron		
		KZ Highly Fluorinated Fluorocarbon Rubber			10 10 micron		
					5 5 micron		

## How to Order Additional Options

**Oxygen Cleaning:** Add the suffix **-C3** to the end of the part number to receive stream switching systems or accessories cleaned and assembled for oxygen service in accordance with Parker specification ES8003.

Add the suffix **-RTK** to the end of the part number to receive stream switching systems or accessories coated with the inert, silicon-based chemical coating Silconert™ 1000 (formerly Silcosteel®).

Add the suffix **-SUL** to the end of the part number to receive stream switching systems or accessories coated with the inert, silicon-based chemical coating Silconert™ 2000 (formerly Sulfinert®).

**NACE:** Add the suffix **-NC** to the end of the part number to receive stream switching systems or accessories that meet the material requirements of ANSI/NACE MR0175/ISO 15156-1.

# Gen II R-max™

## How to Order Kits - Fast Loop Filters

In using this section, the items in **BOLD CAPITALIZED PRINT** are included within the part number of the Kit. The italicized items require a designator to complete the part number. Refer to the How To Order section on page 20 for the designators.

**Filter Seal Kit:** Components required to replace the O-rings.



**Example:** **KIT** - **FR2** - **V**

This example describes a kit consisting of fluorocarbon O-rings and maintenance instructions.

**Filter Element Kit:** Components to replace the filter element.

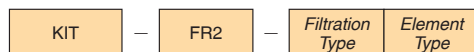

**Example:** **KIT** - **FR2** - **P** **93**

This example describes a kit consisting of a 93% filtration particulate filter element.

**Filter Element & Sample Kit:** Components to replace the filter element and O-rings.

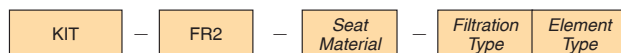

**Example:** **KIT** - **FR2** - **V** - **C** **99**

This example describes a kit consisting of fluorocarbon O-rings, 99% filtration coalescing filter element and maintenance instructions.

# Gen II R-max™

## Application: CEMS (Continuous Emissions Monitoring System)

The Parker Gen II R-max™ stream selection system can be configured for Continuous Emissions Monitoring and associated stack gas monitoring applications, analyzer calibration and validation routines that are crucial for maintaining environmental compliance. These environmental regulations require a complete system check and validation which includes the sample extraction probe, transport lines, sample conditioning system, as well as the analyzer.

The complete system check is called an “Up-Stack” calibration. This Up-Stack calibration can be easily achieved by inserting a “diverter” module into the Parker Gen II R-max™ system. The diverter valve will direct the selected calibration gas either up the stack or allow the gas to go directly to the analyzer. To perform an up-stack calibration simply actuate the diverter valve. Multiple diverter valves can be added if there is more than one stack.

Stream Selection

### CEMS Example 1

The Calibration Stream 2 is in the “on” position and flowing through the Parker Gen II R-max™ system and out to Sample Conditioner.

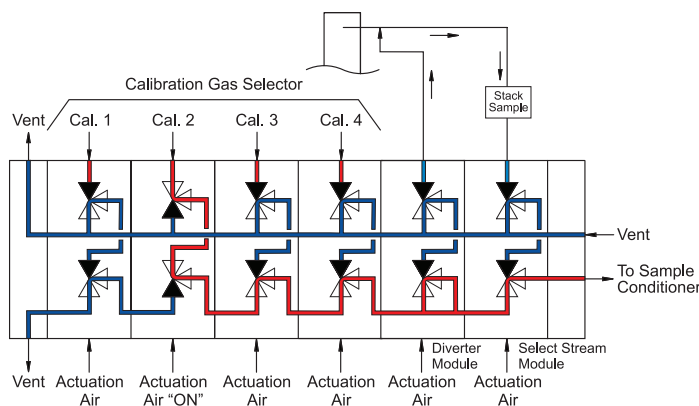

### CEMS Example 2

The Calibration Stream 4, Diverter Module and Stream Selector Module are in the “on” position. Calibration gas is flowing through the Diverter Valve to the Stack and then back through the Stream Selector Module to the Sample Conditioner.

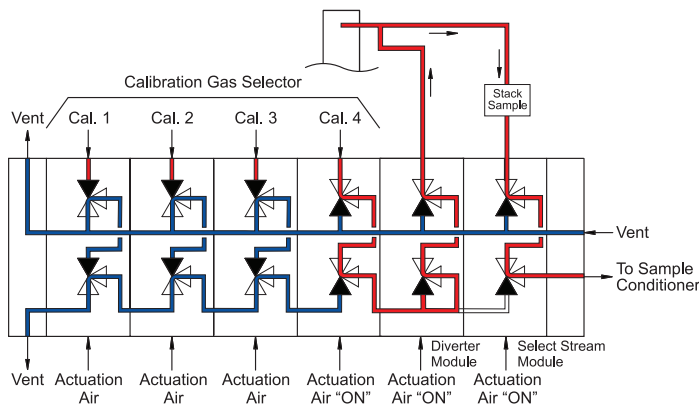

## How to Order

**Example part number: 2F-R3DMSK-V-SS-4-FF**

To order the Parker Gen II R-max™ stream selection system for use in CEMS related applications, the part numbering is identical to the How to Order on page 10 with the exception of the base options. To determine this, choose from the following options.

Base Options	Description
<b>DMS</b>	Distributor module and standard module
<b>DMSGC</b>	Distributor module, standard module and ARV module

# Gen II R-max™

## Parker Gen II R-max™ Stream Switching System and Parker IntraFlow™

The Parker Gen II R-max™ Stream Switching System is also available on the IntraFlow™ ANSI/ISA-76.00.02 Compliant Modular Surface Mount System. All the features and benefits such as the enhanced visual indicator and captured vent available to the Parker Gen II R-max™ can also be achieved on the modular platform.

Refer to Catalog 4250 for further information regarding the Parker IntraFlow™ Modular Surface Mount Systems.

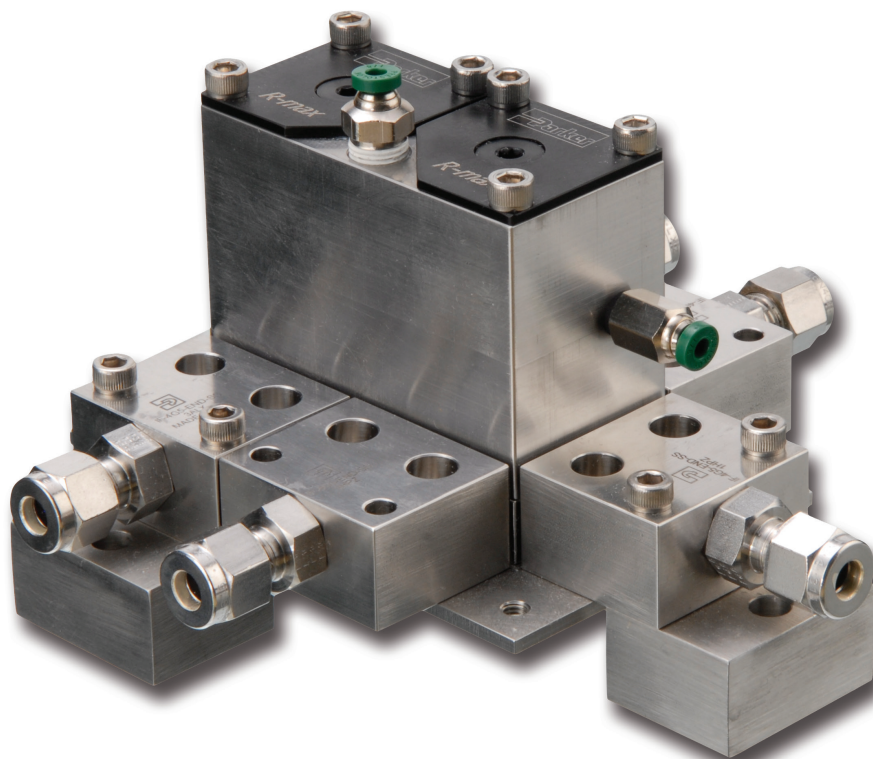

Stream  
Selection

All aspects of the Parker Gen II R-max™ Stream Switching System are available within the IntraFlow™ product line. This includes standard modules, atmospheric reference vent (ARV) modules and normally open modules. Single valve units and filters are also available. The modular design of the IntraFlow™ system allows for maximum flexibility within a minimal space.

# Gen II R-max™

Application: NEED TITLE HERE

Stream Selection

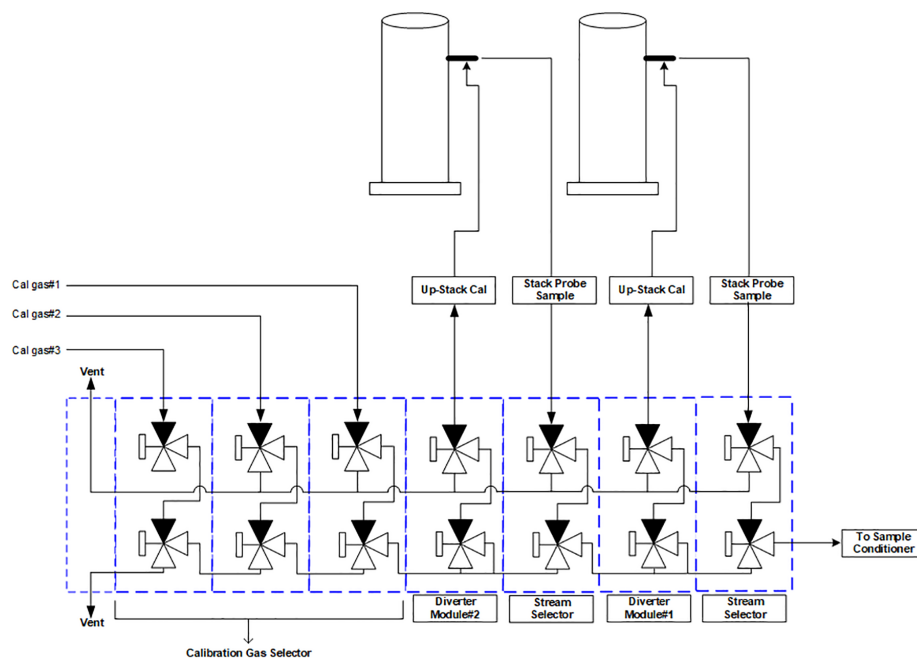

Application: NEED TITLE HERE

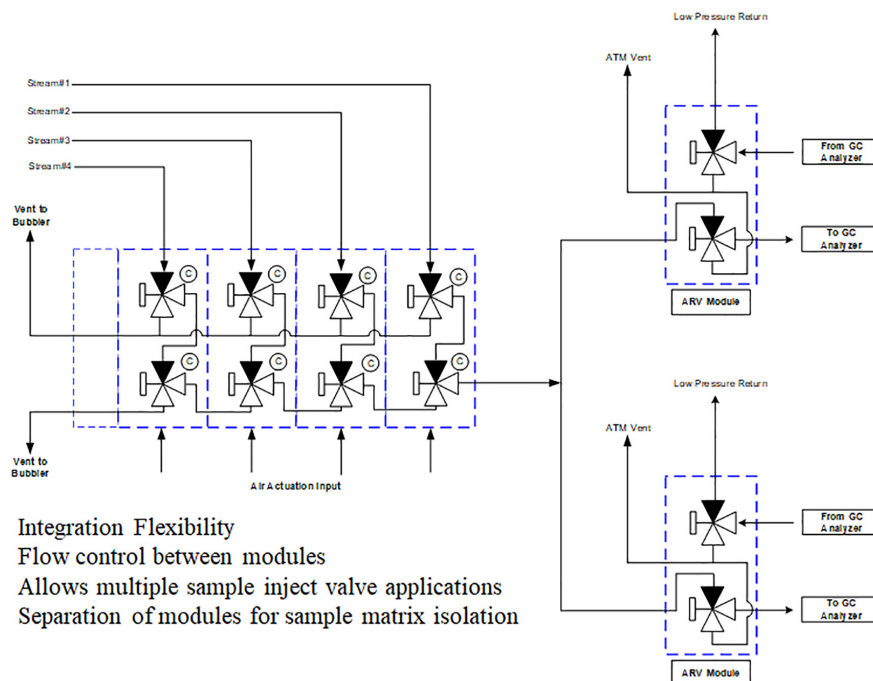

# Gen II R-max™

Application: NEED TITLE HERE

**Single 3-Way R-Max II**  
2F-R3SK-V-SS-F

-Valve Assembly non-Actuated

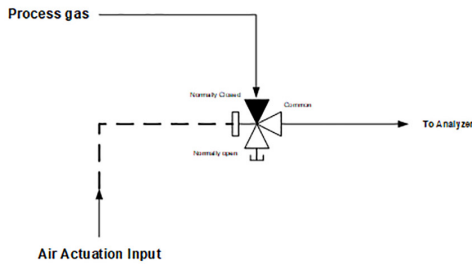

**Single 3-Way R-Max II**  
2F-R3SK-V-SS-F

-Valve Assembly Actuated

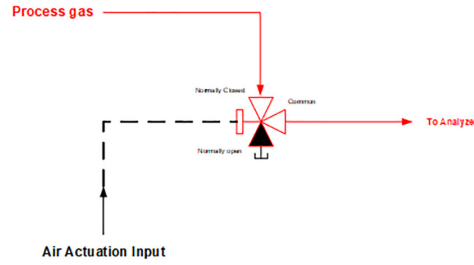

Stream Selection

Application: NEED TITLE HERE

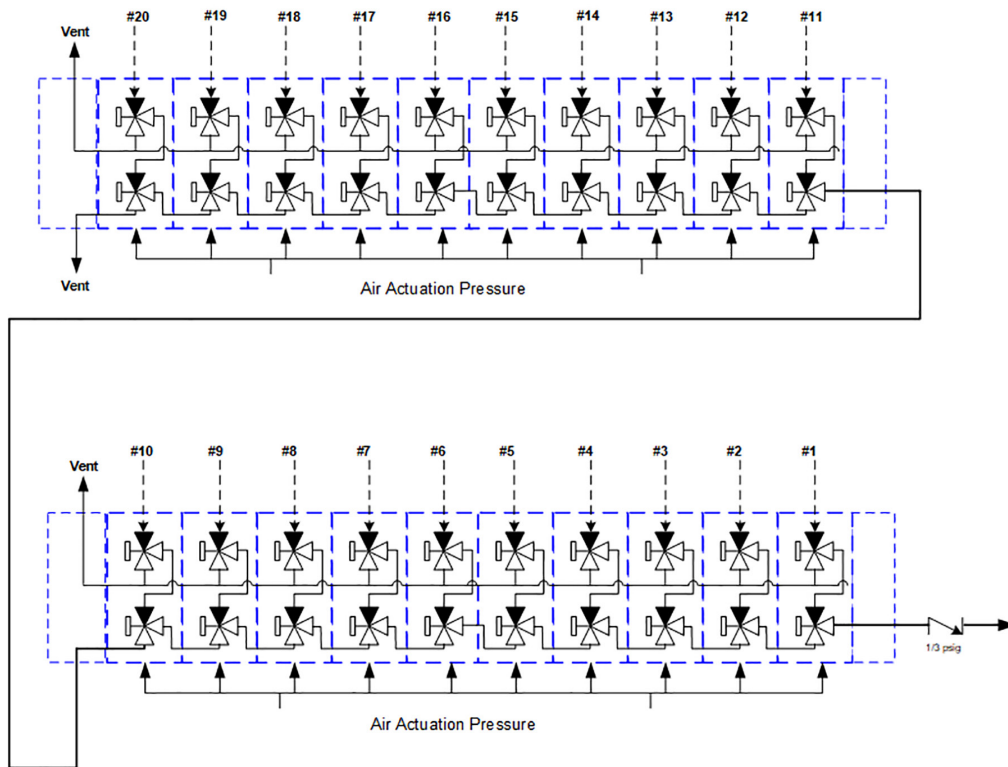

# Parker T-Max™

## PTFE Stream Switching Assembly

General Purpose • Stainless Steel



Stream Selection

The Parker T-Max combines the unique flexibility and functionality of a modular stream switching valve with the proven reliability of a PTFE manifold for harsh applications.

### Overview:

- Utilizes Parker Veriflo Division PV-22 valves in a custom manifold
- Low Internal volume
- 100% factory tested
- Various end configurations

### Materials:

- Wetted: PTFE, PFA, modified PTFE
- Non-Wetted: PFA, PVDF, Viton, and PVDF coated SS Spring

### Specifications:

- Pressure Rating: 26"Hg - 80 psig (5.4 bar)
- Actuation Pressure: 60-100 psig (4.7–8.1 bar)
- Temperature Range: 0-120°F Ambient  
32-212°F Media
- $C_v = 0.33$

### Features and Benefits:

FEATURES	BENEFITS
PTFE and modified PTFE wetted paths	Increased corrosion resistant in aggressive process streams
Modular Configuration	Ease of maintenance and reduced downtime required for valve replacement
Position Indicator	Local indication of valve "on" and "off"
Dedicated ARV for gas sample GC applications	Allows the sample shut-off and equilibration of the sample loop pressure to atmosphere

# Parker T-Max™ : PTFE Stream Switching Assembly

## View and Flow Schematics:

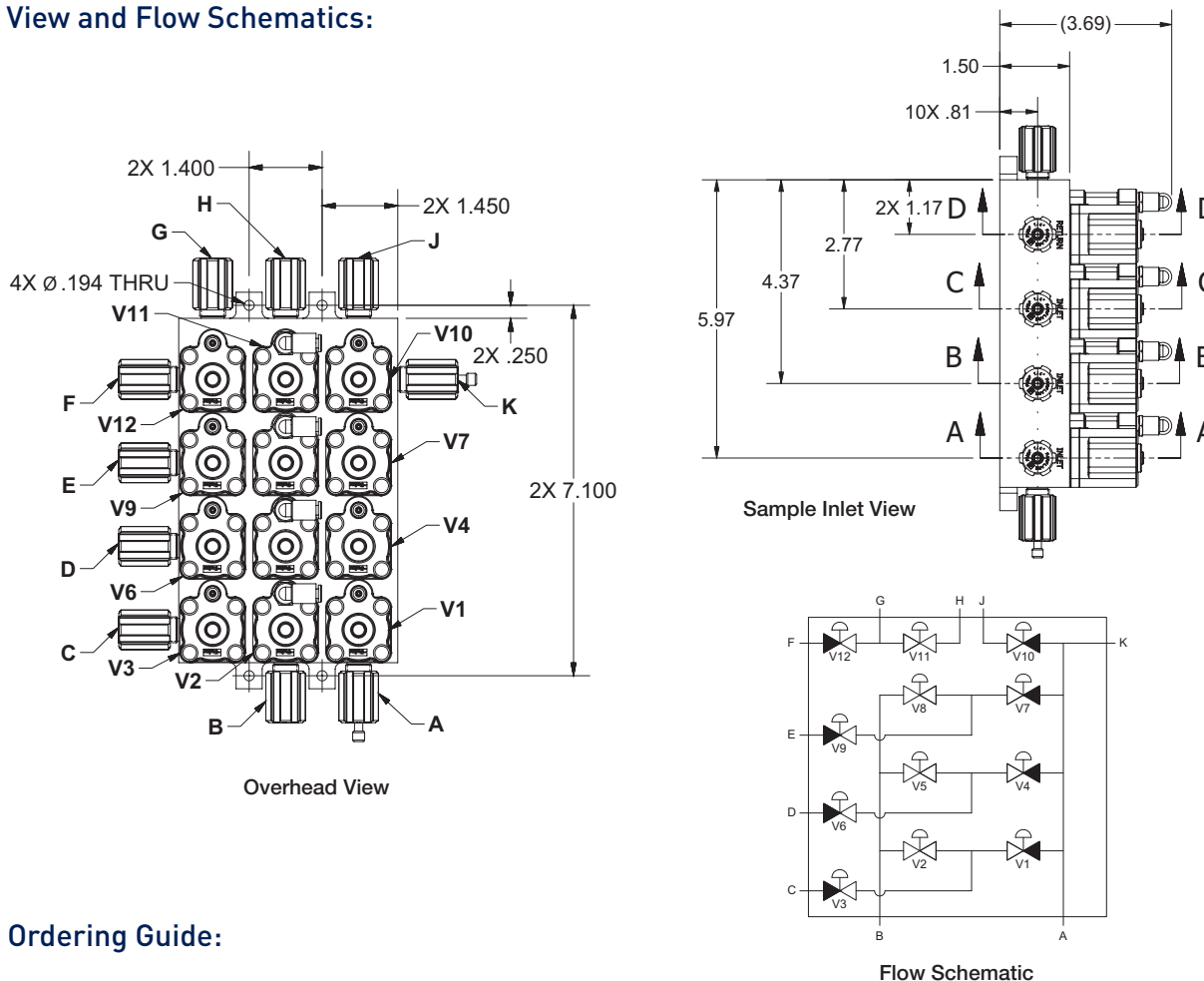

Stream Selection

## Ordering Guide:

Building a Part Number: Example: **CPRT4PFTSV22GC3**

Example Part Number:	<b>CPRT</b>	<b>4PF</b>	<b>TSV</b>	<b>22</b>	<b>GC</b>	<b>3</b>
Ordering Parameters/Options:	Base Model	Connector Options*	Product Designator	Valve Type	Manifold	Number of Streams
Table Reference: (see below)	A	B	C	D	E	F

EXAMPLE DESCRIPTION: Parker T-Max™ CPRT base model with 1/4" flare connections and a 3 stream assembly with a GC manifold module.

A - Base Model	
<b>CPRT</b>	Base Model

B - Connector Options*	
<b>4PF</b>	1/4" Parflange Nut

C - Product Designator	
<b>TSV</b>	PTFE Stream Switching

D - Valve Type	
<b>22</b>	PV22

E - Manifold	
<b>GC</b>	ARV Module (GC not available with 4 stream assembly)
Blank	Standard

F - Number of Streams	
<b>1</b>	1 Stream
<b>2</b>	2 Streams
<b>3</b>	3 Streams
<b>4</b>	4 Streams

**Notes:**  
\* The standard Parflange nut is PVDF

# NOVA & NOVA AOP Series

## Diaphragm Valve, Manual and Air Actuated

General Purpose • Stainless Steel



### Value Proposition:

The NOVA Series valves are economical, general purpose diaphragm valves for regulator outlet valves, gas control panels, & analyzer sampling system applications. Standard construction includes a 316L Stainless Steel body, various seat materials, and an Elgiloy® diaphragm with metal-to-metal external seal for leak integrity.

The NOVA AOP Series Air Actuated Diaphragm Valve is a derivative of the NOVA manually operated valve and is available in normally open (NO) or normally closed (NC) configurations. A choice of two line pressures are available: 250 psig and 500 psig.

Valves

### Product Features:

- High Cycle Life
- Compact Size
- Positive, consistent shutoff
- Metal to Metal seal to atmosphere
- Low Internal volume
- Low actuation pressure for AOP configuration

# NOVA / NOVA AOP Series

## NOVA Series Specifications:

Functional Performance	
Pressure Ratings	
<b>Operating Pressure</b>	
Manual Valve	Vacuum to 3500 psig (241 bar)
<b>Proof Pressure</b>	5,250 psi (362 bar)
<b>Burst Pressure</b>	10,500 psi (724 bar)
AOP1, AOP3 Valve	Vacuum to 250 psig (17 bar)
<b>Proof Pressure</b>	375 psi (26 bar)
<b>Burst Pressure</b>	750 psi (52 bar)
AOP2, AOPNO Valve	Vacuum to 500 psig (34 bar)
<b>Proof Pressure</b>	750 psi (52 bar)
<b>Burst Pressure</b>	1,500 psi (103 bar)
<b>Seat Leakage Class</b>	Bubble Tight
<b>Temperature Rating</b>	-15°F to 150°F (-26°C to 66°C)
<b>Flow Capacity</b>	C <sub>v</sub> = 0.17
<b>Orifice Diameter</b>	.125 inch (3.2 mm)
<b>Internal Volume</b>	Less than 1.0 cc
<b>Approximate Weight</b>	.9 oz. (0.26 kg)

Maximum Actuation Air Pressure	
AOP1 (normally closed)	65 psig (4.5 bar)
AOP2 (normally closed)	75 psig (5.2 bar)
AOP3 (normally closed)	40 psig (2.8 bar)
AOPNO (normally open)	50 psig (3.5 bar)

Material of Construction	
Wetted	
Body	316L Stainless Steel (std)
Diaphragm	Elgiloy®
Seat	PCTFE (std), PEEK™, Vespel®
Non-Wetted	
Bonnet Nut	316 Stainless Steel
Stem	316 Stainless Steel
Knob/Lever	ABS/Aluminum
AOP Actuator	Aluminum

Elgiloy® is a registered trademark of Elgiloy Company  
 Vespel® is a registered trademark of DuPont Performance Elastomers L.L.C.  
 PEEK™ is a registered trademark of Victrex plc.

Valves

# NOVA / NOVA AOP Series

## NOVA Series Flow Curves:

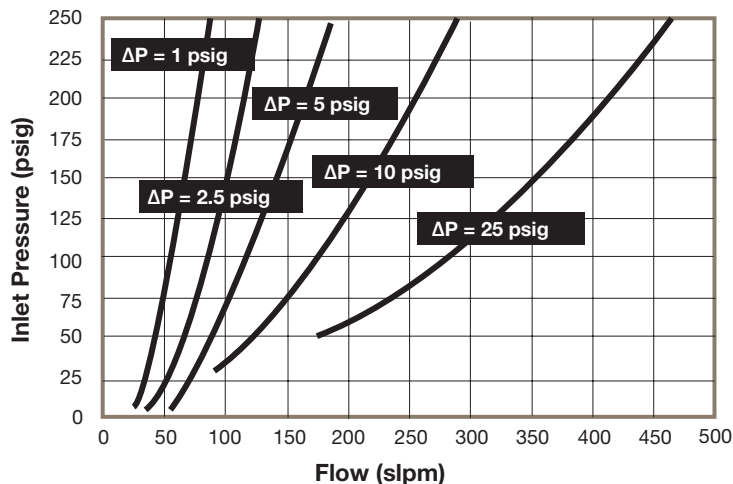

Valves

## NOVA Series Actuation Air Pressure vs. Valve Inlet Pressure:

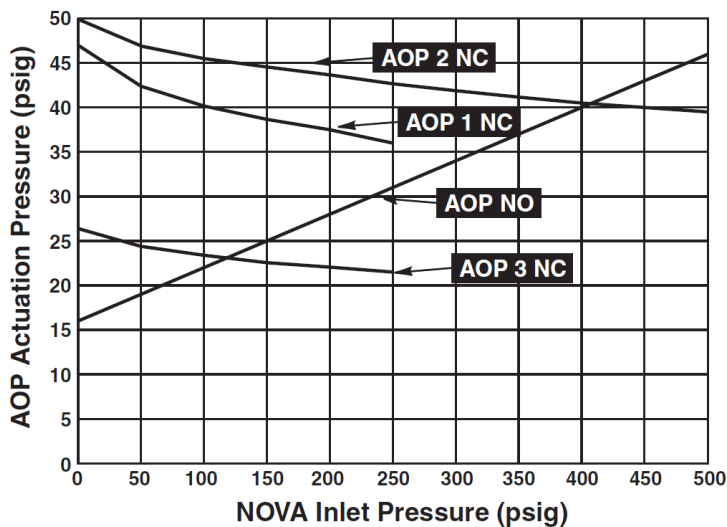



# NOVA / NOVA AOP Series

## NOVA Series Ordering Information:

Building a Part Number: *Example: NOVAS44FF*

Example Part Number:	NOVA	S	44FF	
Ordering Parameters/Options:	Series	Material	Connections	Options
Table Reference: (see below)	A	B	C	D

A - Series	
NOVA	Multi-Turn Handwheel
NOVAI	Indicating Knob
NOVAL	Lever

B - Material	
S	316L Stainless Steel

C - Connections	
44TT	1/4" Compression In and Out
44FF	1/4" Female NPT In and 1/4" Female NPT Out
44MM	1/4" Male NPT In and 1/4" Male NPT Out
44MF	1/4" Male NPT In and 1/4" Female NPT Out

D - Options	
MH	Mounting Holes
PM	Panel Mount
PEEK	PEEK™ Seat
VESP	Vespeℓ® Seat

**Notes:**  
 Panel Mount Option is not available with Indicating Knob  
 Vespeℓ® is a registered trademark of DuPont Performance Elastomers L.L.C  
 PEEK™ is a registered trademark of Victrex plc.  
 Compression Ends include Nuts and Ferrules

Valves

## NOVA AOP Series Ordering Information:

Building a Part Number: *Example: NOVA AOP1S44TT*

Example Part Number:	NOVA AOP	1	S	44TT	
Ordering Parameters/Options:	Series	Style	Material	Connections	Options
Table Reference: (see below)	A	B	C	D	E

A - Series	
NOVA AOP	Air Operated

B - Style	
1	Normally Closed - 250 psig
2	Normally Closed - 500 psig
3	Normally Closed - 250 psig
NO	Normally Open - 500 psig

C - Material	
S	316L Stainless Steel

D - Connections	
44FF	1/4" Female NPT In and 1/4" Female NPT Out
44MM	1/4" Male NPT In and 1/4" Male NPT Out
44MF	1/4" Male NPT In and 1/4" Female NPT Out
44TT	1/4" Compression In x 1/4" Compression Out

E - Options	
MH	Mounting Holes
PEEK	PEEK™ Seat
VESP	Vespeℓ® Seat

**Notes:**  
 Vespeℓ® is a registered trademark of DuPont Performance Elastomers L.L.C  
 PEEK™ is a registered trademark of Victrex plc.  
 Compression Ends include Nuts and Ferrules

# NV17 Series

## Diaphragm Valve

### Manual and Air Actuated

General Purpose • Stainless Steel



#### Value Proposition:

The Parker's NV17 Series is comprised of economical, high-performance, high-cycle diaphragm valves ideal for a variety of applications. Typical usage includes shutoff, isolation, gas control panels, Change Over Systems, and analyzer sampling systems.

The NV17 AOP Series Air Actuated Diaphragm Valve is a derivative of the NV17 manually operated valve and is available in normally open (NO) or normally closed (NC) configurations. A choice of two line pressures are available: 250 psig and 500 psig.

Valves

#### Product Features:

- Internally threadless and springless
- High Cycle Life
- Compact Size
- Positive, Consistent Shutoff
- Metal-to-Metal External Seal
- Low Internal Volume
- Low Actuation Pressure for AOP Configuration
- Tamper-Resistant Bonnet Design

#### NV17 Series Specifications:

Functional Performance	
<b>Pressure Ratings</b>	
Manual Valve	Vacuum to 3500 psig (241 bar)
AOP1, AOP3	Vacuum to 250 psig (17 bar)
AOP2, AOPNO	Vacuum to 500 psig (34 bar)
<b>Proof Pressure</b>	5,250 psi (362 bar)
<b>Burst Pressure</b>	14,000 psi (965 bar)
<b>Leak Rate: Internal/External</b>	Bubble Tight
<b>Temperature Rating</b>	-40°F to 150°F (-40°C to 66°C)
<b>Flow Capacity</b>	C <sub>v</sub> = 0.17
<b>Internal Volume</b>	Less than 1.0 cc
<b>Approximate Weight</b>	0.56 lbs. (0.26 Kg)

Maximum Actuation Air Pressure	
AOP1 (normally closed)	65 psig (4.5 bar)
AOP2 (normally closed)	75 psig (5.2 bar)
AOP3 (normally closed)	40 psig (2.8 bar)
AOPNO (normally open)	50 psig (3.5 bar)

Material of Construction	
Wetted	
Body	316L Stainless Steel (std)
Diaphragm	Elgiloy®
Seat	PCTFE (std), PEEK™, Vespel®
Non-Wetted	
Cap Nut	316 Stainless Steel
Stem	416 Stainless Steel
Knob/Lever	ABS/Aluminum
AOP Actuator	Aluminum

Elgiloy® is a registered trademark of Elgiloy Company  
Vespel® is a registered trademark of DuPont Performance Elastomers L.L.C.  
PEEK™ is a registered trademark of Victrex plc.

# NV17 Series

## Flow Curve:

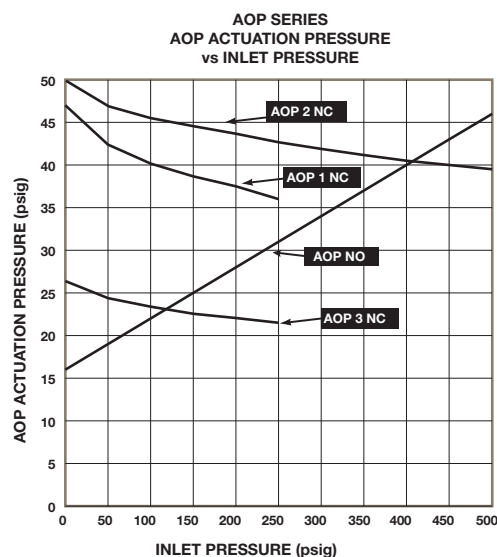
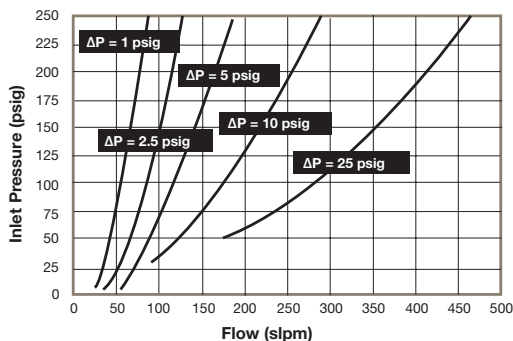

Valves

## Ordering Information:

Building a Part Number: *Example: NV17AOP2S44MFVESP*

Example Part Number:	NV17	AOP2	S	44MF	VESP
Ordering Parameters/Options:	Series	Type	Material	Connections	Optional Features
Table Reference: (see below)	A	B	C	D	E

### A - Series

NV17	NV17 Series Valve
------	-------------------

### B - Type

AOPNO	Air Operated, Normally Open
AOP1	Air Operated, Normally Closed
AOP2	Air operated, Normally Closed
AOP3	Air operated, Normally Closed
I	Indicating Handwheel
L	Lever
S	Spin Handwheel

### C - Material

S	316LStainless Steel
---	---------------------

### D - Connections

44TT	1/4" Compression In and Out
44FF	1/4" Female NPT In and Out
44MM	1/4" Male NPT In and Out
44MF	1/4" Male NPT In and Female NPT Out

Compression ends include nuts and ferrules

### E - Optional Features

PEEK	PEEK™ Seat
VESP	Vespe® Seat

Vespe® is a registered trademark of DuPont Performance Elastomers L.L.C.  
PEEK™ is a registered trademark of Victrex plc.

# NV17 Series

## Dimensional Drawing:

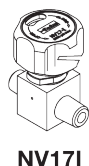
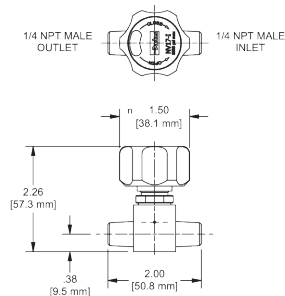

**NV17I**

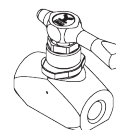
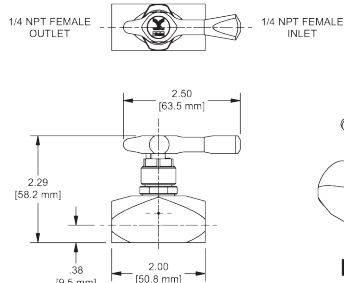

**NV17L**

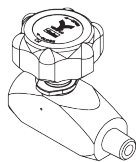
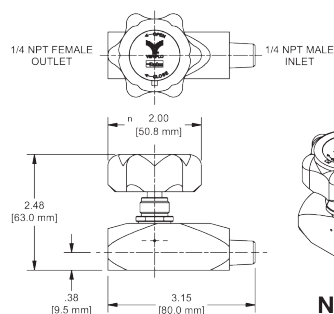
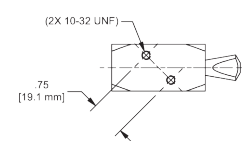
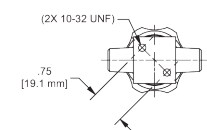

**NV17S**

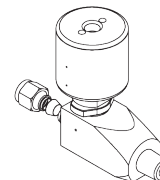
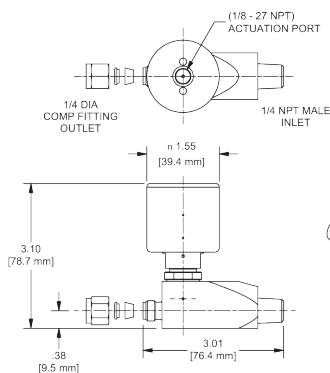

**NV17AOP3**

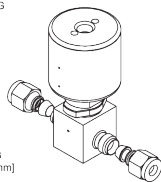
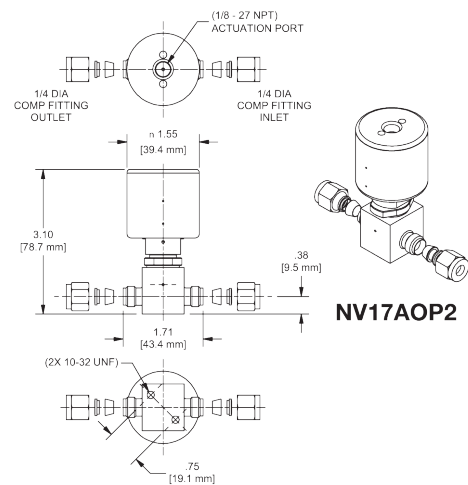
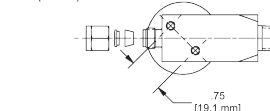
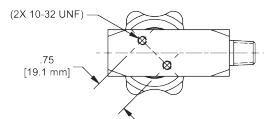

**NV17AOP2**

Valves

# NV55 Series

## High Flow, Compact Valve

Metal Diaphragm Seal • High Cycle Life • Stainless Steel



### Value Proposition:

The NV55 is an economical, general purpose, high flow diaphragm valve ideally suited for use when flowing large volumes of corrosive and non-corrosive fluids. This compact, 316L stainless steel valve ensures positive and consistent shut off with manual or air actuation. The NV55 offers an Elgiloy® diaphragm and a metal-to-metal seal to atmosphere for leak integrity.

Valves

### Product Features:

- Internally threadless and springless
- High cycle life
- Compact size
- Positive, consistent shut off
- Metal to metal seal to atmosphere
- Ideal for high flow applications
- Fully functional from vacuum to 125 psig for AOPLPNO valves / 250 psig for manual and AOPLPNC valves
- Oxygen cleaned in accordance with ASTM G93 Level C

### Specifications:

Functional Performance	
<b>Design</b>	
Burst Pressure	750 psig (52 barg)
Proof Pressure	375 psig (26 barg)
<b>Flow Capacity</b>	
AOP versions, Indicator Knob and Handwheel	C <sub>v</sub> 0.55
Lever Version	C <sub>v</sub> 0.48
<b>Leak Rate</b>	
Internal	Bubble Tight
External	Bubble Tight
<b>Internal Volume</b>	3.29 cc
<b>Approximate Weight</b>	0.81 lbs. (0.36 kg)

Operating Conditions	
<b>Operating Pressure</b>	
Manual, AOPLPNC	Vacuum to 250 psig (17.2 barg)
AOPLPNO	Vacuum to 125 psig (8.6 barg)
AOP Activation Pressure	70-125 psig (4.8 -8.6 barg)
<b>Temperature</b>	
Bake Out	250°F (121°C) in the open position

Material of Construction	
Wetted	
Body Options	316L Stainless Steel
Diaphragm Options	Elgiloy® or equivalent
Seal Options	PCTFE (std), PEEK™ or Vespel®
Non-Wetted	
Nut	17-4 PH
Cap	17-4 PH
Actuation Devices	
AOP	Aluminum
Indicator Knob	Aluminum (Black)
Levers	Zinc Alloy, Powder Coated (Blue)
Handwheel	ABS (Black)

For additional information on materials of construction, functional performance and operating conditions, please contact factory.

Elgiloy® is a registered trademark of Elgiloy Company  
 PEEK™ is a trademark of Victrex plc.  
 Vespel® is a registered trademark of DuPont Performance Elastomers L.L.C

# NV55 Series

## Flow Curve:

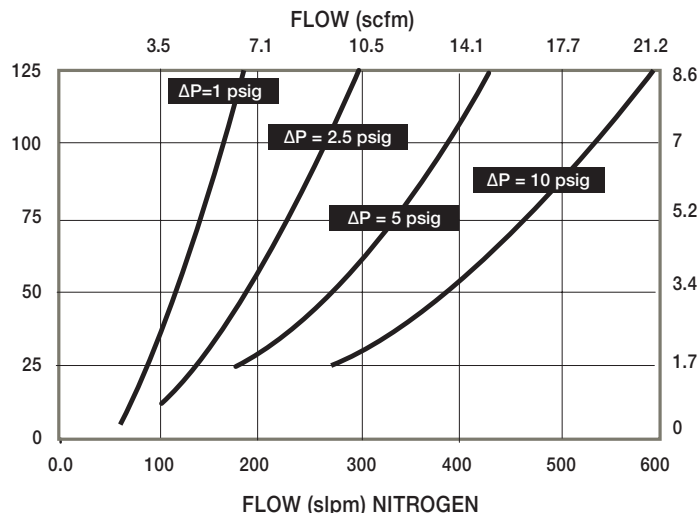

Valves

## Dimensional Drawing:

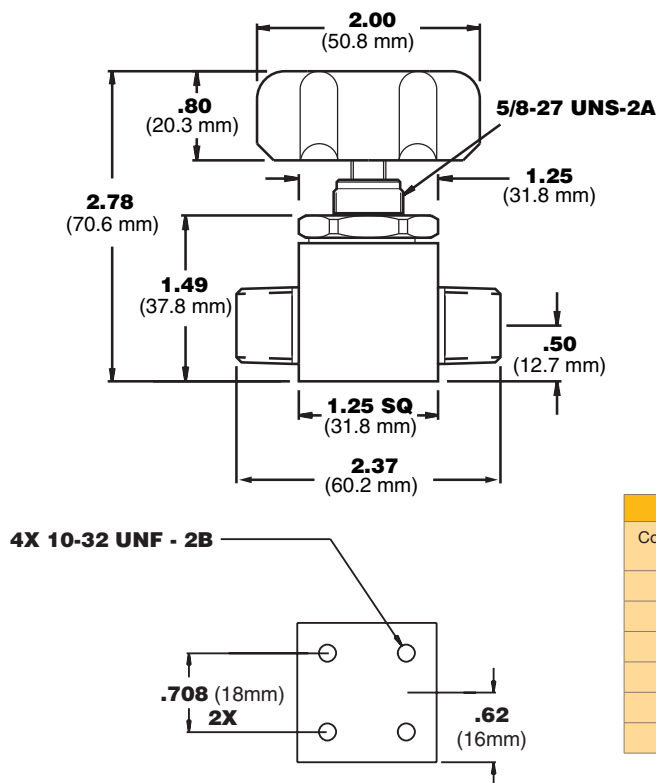

DIMENSION TABLE	
Connection Type	End to End Dimensions
44MM	2.37 (60.198 mm)
44FF	2.37 (60.198 mm)
44TT	2.06 (52.324 mm)
66MM	2.37 (60.198 mm)
66FF	2.37 (60.198 mm)
66TT	2.19 (55.626 mm)

# NV55 Series

## Ordering Information:

Building a Part Number: *Example: NV55LLS44MMVESP*

Example Part Number:	NV55	LL	S	44MM	VESP
Ordering Parameters/Options:	Series	Type	Body Material	Connection	Optional Features
Table Reference: (see below)	A	B	C	D	E

### A - Series

NV55	NV55 Series Valve
------	-------------------

### B - Type

AOPLPNC	Air Operated, Low Pressure, Normally Closed
AOPLPNO	Air Operated, Low Pressure, Normally Open
I	Indicator Knob
L	Lever
LL	Locking Lever
M	Mini Lever
S	Spin Handwheel

### C - Body Material

S	316L Stainless Steel
---	----------------------

### D - Connection (Compression ends include nuts and ferrules)

44MM	1/4" Male NPT In and Out
44FF	1/4" Female NPT In and Out
44TT	1/4" Compression In and Out
66MM	3/8" Male NPT In and Out
66FF	3/8" Female NPT In and Out
66TT	3/8" Compression In and Out

### I - Optional Features (This section can have multiple options)

PM	Panel Mount (Not available with Indicator Knob (I) or AOP units (AOPLPNC or AOPLPNO))
PEEK	PEEK™ Seat (Not available with VESP Option)
VESP	Vespe ® Seat (Recommended for N <sub>2</sub> O Service. Not available with PEEK Option)

Valves

# NV70 Series

## High Pressure, Compact Size Diaphragm Valve

Stainless Steel



### Value Proposition:

The NV70 is an economical, general purpose, high flow diaphragm valve ideally suited when flowing large volumes of corrosive and non-corrosive fluids. This compact, 316L stainless steel valve ensures positive and consistent shut off with manual or air actuation. The NV70 uses a high fatigue strength diaphragm (Elgiloy®) that creates an external metal seal, and provides a reliable seal to atmosphere.

### Product Features:

- Internally threadless and springless
- High Life Cycle
- Compact Size
- Positive, Consistent Shutoff
- Metal-to-Metal Seal to atmosphere
- Ideal for High Flow Applications
- Fully functional from vacuum to 150 psig for AOPLPNO / AOPLPNC valves and 250 psig for manual valves
- Oxygen cleaned in accordance with ASTM G93 Level C

Valves

### Specifications:

Functional Performance	
<b>Design</b>	
Burst Pressure	750 psig (52 barg)
Proof Pressure	375 psig (26 barg)
<b>Flow Capacity</b>	
AOP versions, indicator Knob and Handwheel	C <sub>v</sub> 0.7
<b>Leak Rate</b>	
Internal	Bubble Tight
External	Bubble Tight
<b>Internal Volume</b>	4.90 cc
<b>Approximate Weight</b>	1.20 lbs. (0.55 kg)

For additional information on materials of construction, functional performance and operating conditions, please contact factory.

Material of Construction	
Wetted	
Body	316L Stainless Steel
Diaphragm	Elgiloy® or equivalent
Seat Options	PCTFE (std.) or Polyimide
Non-Wetted	
Cap	17-4 PH Stainless Steel
Nut	17-4 PH Stainless Steel
Actuator Housing	Anodized Aluminum
Operating Conditions	
<b>Maximum Pressure</b>	
AOP	150 psig (10.3 barg)
Manual	250 psig (17.2 barg)
<b>Minimum Pressure</b>	Vacuum
AOP Actuation Pressure	70-125 psig
AOP Air inlet	1/8" NPT (AOPLP Only)
<b>Temperature</b>	-40°F to 150°F (-40°C to 66°C)

# NV70 Series

## Flow Curve:

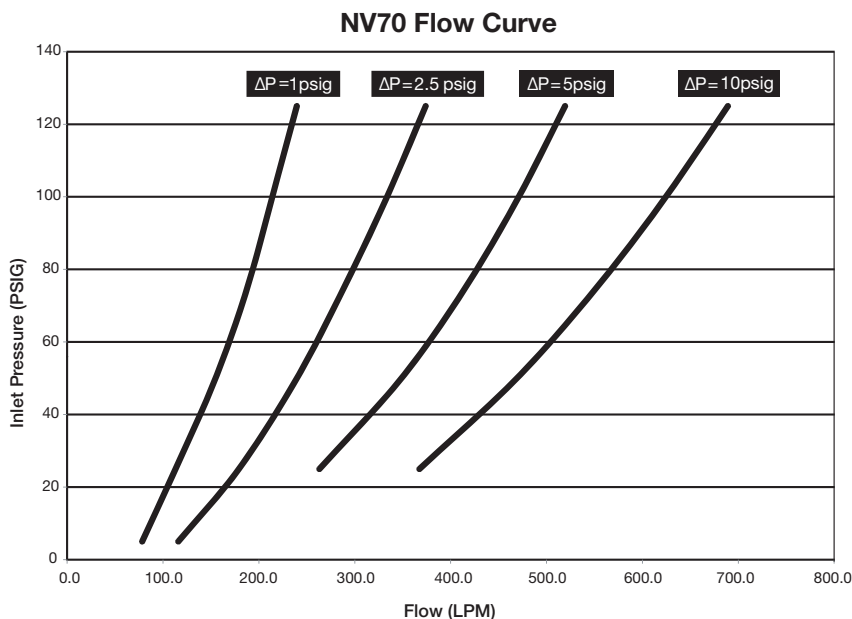

Valves

## Ordering Information:

Building a Part Number: *Example: NV70IS88TTPI*

Example Part Number:	NV70	I	S	88TT	PI
Ordering Parameters/Options:	Series	Type	Material	Connections	Optional Features
Table Reference: (see below)	A	B	C	D	E

### A - Series

NV70	NV70 Series Valve
------	-------------------

### B - Type

AOPLPNC	Air Operated, Lower Pressure, Normally Closed
I	Indicating Handwheel
S	Spin Handwheel
AOPLPNO	Air Operated, Lower Pressure, Normally Open

### C - Material

S	Stainless Steel
---	-----------------

### D - Connections

88TT	1/2" Compression in and Out
88FF	1/2" Female NPT In and Out
88MM	1/2" Male NPT In and Out

Compression ends include nuts and ferrules

### E - Optional Features

PI	Polyimide Seat
----	----------------

**Note:**  
Panel Mount Option: Order Panel Nut Ring (PN: 6-PANEL-NUT-SS) as separate line item.

# NV70 Series

## Dimensional Drawing:

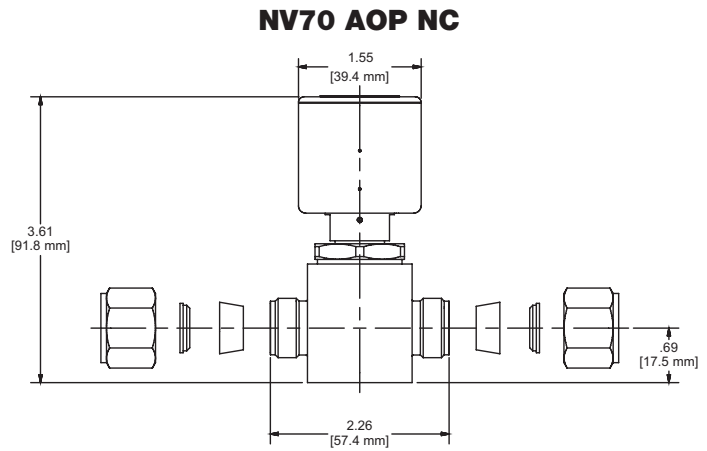
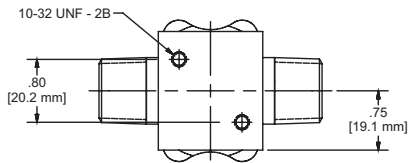
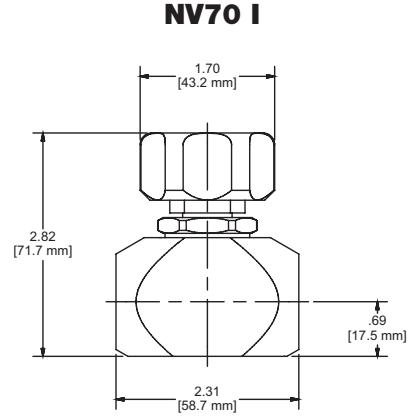
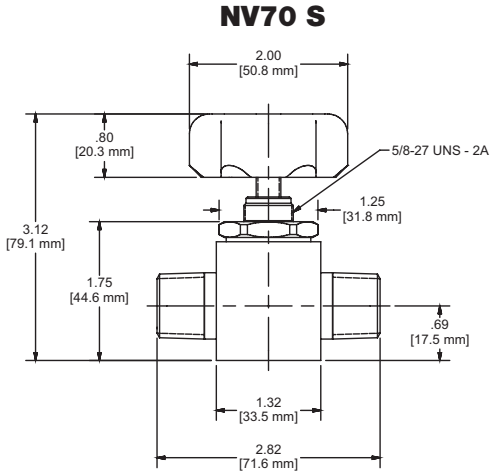

Valves

# FS190 Series

## Excess Flow Shutoff Valve

Stainless Steel



### Value Proposition:

Parker's FS190 Series excess flow shutoff valve operates within a wide range of inlet pressures from 10 to 3,500 psig. A non-attitude sensitive valve, FS190 can be used between a high-pressure source at the inlet to the pressure regulator or in low-pressure delivery lines to a process. In both applications, this control valve will automatically shut off delivery of gas should the flow exceed the preset limit.

Valves

### Product Features:

- Offered with six different pressure / flow limits
- Differential pressure created is not affected by mounting orientation (non-attitude sensitive)
- Actuating knob designed to manually operate valve and clearly indicate relative operating position - Open (Reset) or Auto (Shutoff)
- Pneumatic actuator available to reset the valve remotely
- Oxygen cleaned in accordance with ASTM G93 Level C

### Specifications:

Functional Performance	
<b>Design</b>	
Burst Pressure	10,500 psig (724 barg)
Proof Pressure	5,250 psig (362 barg)
<b>Leak Rate</b>	
Internal	Bubble Tight
External (NPT Threaded)	Bubble Tight
<b>Internal Volume</b>	1.86 cc
<b>Approximate Weight</b>	12.5 oz. (0.32 kg)
Operating Conditions	
Temperature	-10°F to 150°F (-23°C to 66°C)
Supply Pressure	Based on Flow Limit Setting
A-D Flow Limits:	10 psig to 3,500 psig (0.7 barg to 241 barg)
E-F Flow Limits:	20 psig to 3,500 psig (1.4 barg to 241 barg)
Differential Pressure	5 psig or 12 psig (0.3 barg or 0.8 barg)
Flow Limit Settings	6 available - see Ordering Information section

Material of Construction	
Wetted	
Body	316L Stainless Steel
Compression Member	316L Stainless Steel
Diaphragm	Elgiloy® or equivalent
Poppet	316L Stainless Steel
Spring	Hastelloy® C-22
Orifice	316L Stainless Steel
Seat	PCTFE

Non-Wetted	
Cap	316L Stainless Steel
Stem	303 Stainless Steel
Knob	Aluminum (Red)

For additional information on materials of construction, functional performance and operating conditions, please contact factory.

Hastelloy® C-22 and Hastelloy® C-276 are registered trademarks of Haynes International, Inc. Elgiloy® is a registered trademark of Elgiloy Company.

# FS190 Series

## Flow Curve:

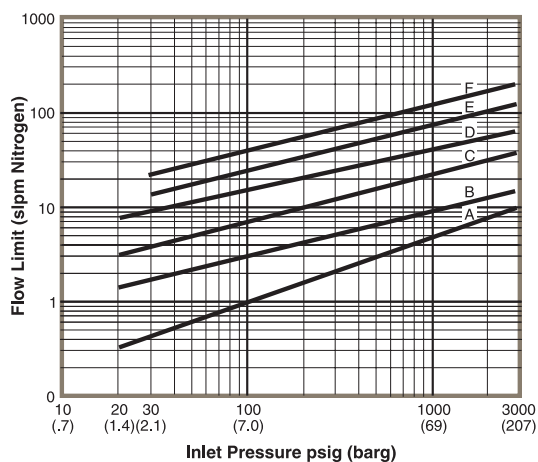

## Ordering Information:

Building a Part Number: <i>Example: FS190SAPAOP</i>					
Example Part Number:	<b>FS190</b>	<b>S</b>	<b>A</b>	<b>P</b>	<b>AOP</b>
Ordering Parameters/Options:	Series	Material	Flow Limit Setting	Connection (Inlet and Outlet)	Optional Features
Table Reference: (see below)	<b>A</b>	<b>B</b>	<b>C</b>	<b>D</b>	<b>E</b>

A - Series	
FS190	FS190 Series Valve

D - Connection (Inlet and Outlet)	
P	1/4" NPTF

B - Body Material	
S	316L Stainless Steel

E - Optional Features (This section can have multiple options)	
AOP	Air Operated

C - Flow Limit Settings (Nominal Flow Limit at:)		
	1,000 psig Inlet	30 psig Inlet
A	4.8 SLPM	0.4 SLPM
B	9.1 SLPM	1.7 SLPM
C	21.8 SLPM	3.9 SLPM
D	39.5 SLPM	9.0 SLPM
E	72.3 SLPM	14.4 SLPM
F	120.6 SLPM	22.5 SLPM

Hastelloy® C-22 and Hastelloy® C-276 are registered trademarks of Haynes International, Inc.

Valves

# VR7 Series

## Pressure Relief Valve

Stainless Steel



### Value Proposition:

The VR7 Series is an economical relief valve designed to vent excess pressure from a regulator should a minor seat leak occur. This valve is recommended for use with regulators to protect the regulator and outlet pressure gauge and is not intended for applications where repeated or frequent venting is required.

**NOTE:** The VR7 **SHOULD ONLY** be used to protect Article 3, Paragraph 3 category equipment as defined in Pressure Equipment Directive 97/23/EC, dated May 29, 1997.

Valves

### Product Features:

- Choice of seal materials for system compatibility
- Hex body provides wrench flats
- Available with a variety of connections
- Oxygen cleaned in accordance with ASTM G93 Level C

### Specifications:

Material of Construction	
Wetted	
Body	316 Stainless Steel
Seal	FKM (std.) or FFKM
Spring	302 Stainless Steel
Poppet	PCTFE
Screw	316L Stainless Steel (std.) or Delrin

Functional Performance	
Flow Capacity	Cv 0.37
Approximate Weight	2.0 oz. (0.06 kg)

Operating Conditions	
Maximum Pressure	750 psig (52 barg)
Temperature	-30°F to 400°F (-35°C to 204°C)
Adjustable Ranges	10-20 psig (0.6 - 1.4 barg) 20-100 psig (1.4 - 7 barg) 100-250 psig (7 - 17 barg) 250-500 psig (17 - 34 barg)

For additional information on materials of construction, functional performance and operating conditions, please contact factory.

# VR7 Series

## Flow Curve:

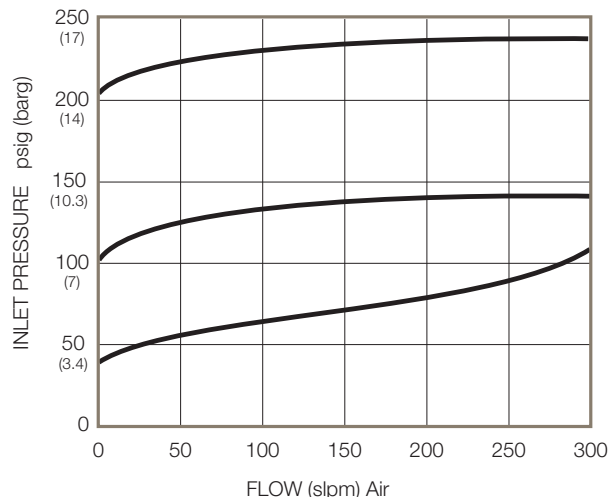

Valves

## Ordering Information:

Building a Part Number: *Example: VR744MF1SV*

Example Part Number:	<b>VR7</b>	<b>44MF</b>	<b>1</b>	<b>S</b>	<b>V</b>
Ordering Parameters/Options:	Series	Connection (Inlet & Outlet)	Adjustable Range	Body Material	Seal
Table Reference: (see below)	A	B	C	D	E

A - Series	
VR7	Pressure Release Valve

D - Body Material	
S	316L Stainless Steel

B - Connection (Inlet and Outlet)	
44MF	1/4" NPTM x 1/4" NPTF
Note: After relieving, service is required.	

E - Seal	
K	FFKM
V	FKM

C - Adjustable Range	
1	10-20 psig
2	20-100 psig
3	100-250 psig
4	250-500 psig

Product is shipped set to maximum setting of Adjustable Range.  
Example: 20-100 psig set to 100 psig. For custom settings please consult factory.

# VR7 Series

Dimensional Drawing:

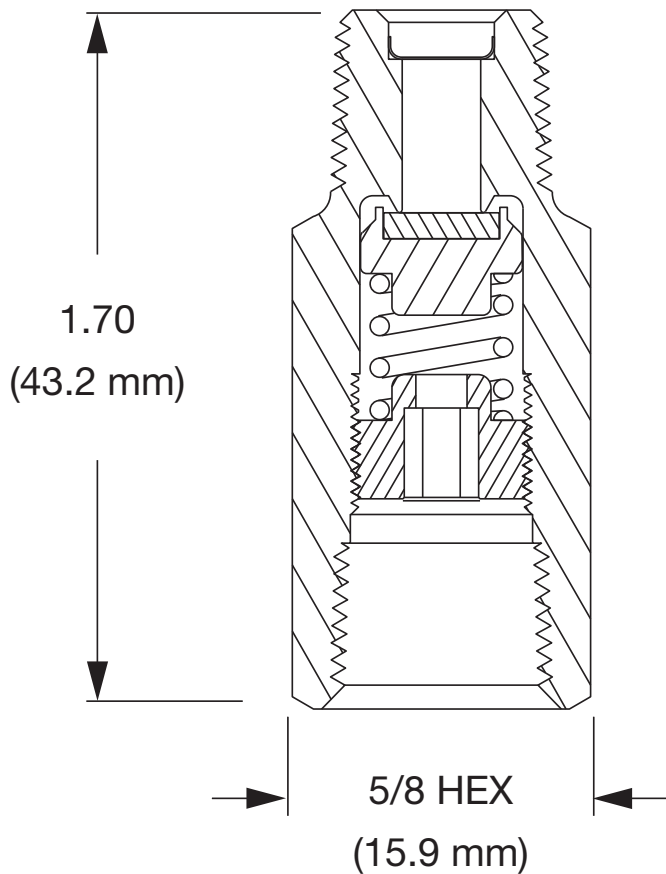

Valves

# IR4000 Series

## Single-Stage, General Purpose Pressure Regulator

Internal Threadless • Stainless Steel



### Value Proposition:

The IR4000 Series regulator offers high pressure capability with an inlet pressure up to 4,000 psig. Its large, convoluted Hastelloy® C-22 diaphragm provides stable pressure control and corrosion resistance. Close tolerances and tight alignment of moving components minimize hysteresis and improve cycle life.

### Product Features:

- Unique compression member loads the seal to the body without requiring a threaded nozzle or additional seals
- Internally threadless design reduces particle generation; low internal volume reduces purge times
- Positive upward and downward stops increase cycle life by preventing over stroking of the diaphragm
- Selection of seat materials for media compatibility and temperature applications
- Oxygen cleaned in accordance with ASTM G93 Level C

### Specifications:

Functional Performance	
<b>Design</b>	
Burst Pressure	12,000 psig (828 barg)
Proof Pressure	6,000 psig (414 barg)
<b>Flow Capacity</b>	
C <sub>v</sub> Options	C <sub>v</sub> 0.06 (std), C <sub>v</sub> 0.02, C <sub>v</sub> 0.15
<b>Leak Rate: Internal</b>	Bubble Tight
<b>Leak Rate: External</b>	Bubble Tight
<b>Supply Pressure Effect</b>	Based upon C <sub>v</sub> Option
0.02 C <sub>v</sub>	0.23 psig/100 psig (0.016 barg/7 barg)
0.06 C <sub>v</sub>	0.6 psig/100 psig (0.04 barg/7 barg)
0.15 C <sub>v</sub>	1.5 psig/100 psig (0.1 barg/7 barg)
<b>Internal Volume</b>	40cc without fittings
<b>Approximate Weight</b>	1.5 lbs. (0.7 kg)
Operating Conditions	
<b>Maximum Inlet</b>	Refer to Range Table for specific information
<b>Outlet Options</b>	0 - 10 psig (.7 barg), 1-30 psig (2 barg) 2 - 60 psig (4 barg), 3-100 psig (7 barg) 10-250 psig (17 barg) 20 - 500 psig (35 barg)
<b>Temperature</b>	Metal Knob required for temperature above 150°F
PCTFE	-40°F to 150°F (-40°C to 66°C)
PEEK™	-40°F to 275°F (-40°C to 135°C)
Vespel®	-40°F to 500°F (-40°C to 260°C)
Self-Relieving Option	-40°F to 150°F (-40°C to 66°C)

Material of Construction	
Wetted	
Body Options	316L Stainless Steel (std). (Contact Factory for Alloyed body material availability)
Compression Member	Inconel® 625
Diaphragm	Hastelloy® C-22
Poppet	Hastelloy® C-22
Poppet Spring	Inconel® X750
Seat Options	PCTFE (std) Vespel® or PEEK™
Carrier Options	316L Stainless Steel (std) or Hastelloy® C-22
Washer Backup Options	316L Stainless Steel (std) or Hastelloy® C-22
O-Ring Backup Options	FKM (std) or PTFE
Inlet Screen/Filter	316 Stainless Steel (std) (60µm mesh screen, 10µm filter) (Contact Factory for Alloyed body material availability)
Self Relieving Seat	PEEK™
Non-Wetted	
Cap Options	Nickel Plated Brass or Stainless Steel
Nut	316L Stainless Steel
Knob Options	ABS (std) (ambient temperature) or Aluminum

For additional information on materials of construction, functional performance and operating conditions, please contact factory.

Hastelloy® is a registered trademark of Haynes International, Inc.  
PEEK™ is a trademark of Victrex plc.  
Vespel® is a registered trademark of DuPont Performance Elastomers L.L.C.  
Inconel® is a registered trademark of Special Metals Corporation

# IR4000 Series

## Flow Curve:

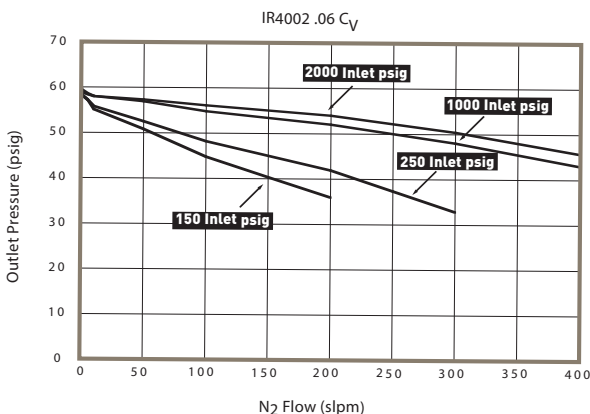
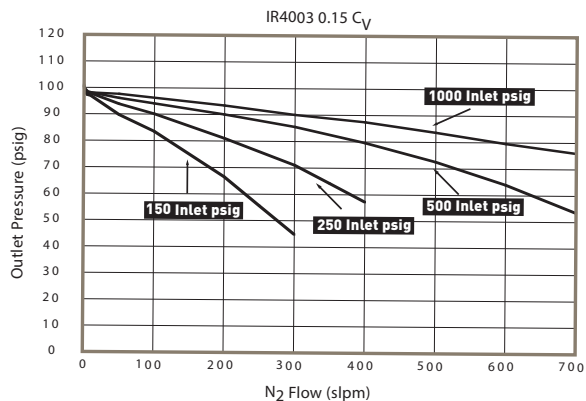
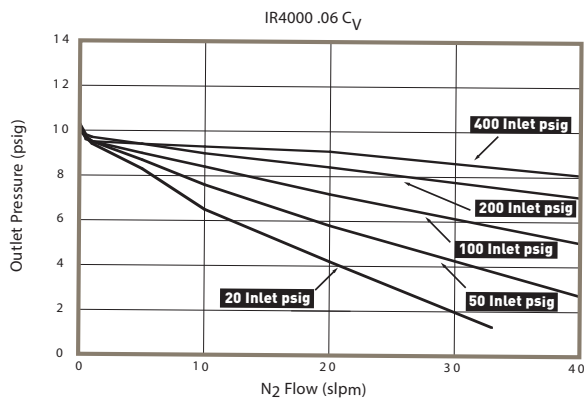

Basic Model	Maximum Inlet PSIG		
	0.02 Cv	0.06 Cv	0.15 Cv
IR4000	400	400	400
IR4001	4,000	4,000	1,250
IR4002	4,000	4,000	1,250
IR4003	4,000	4,000	1,250*
IR4004	4,000	4,000	1,250
IR4005	4,000	4,000	1,250

\*1,250 max. pressure for PEEK and Vespel seats

When setting the delivery pressure, ensure that the maximum outlet pressure of the regulator is not exceeded for any operating condition including increases in delivery pressure due to flow shutoff and supply pressure effect. Supply pressure effect will result in a significant rise in outlet pressure as the inlet pressure decreases.

The stop settings will be adjusted to accommodate typical inlet and outlet pressure ranges. Please contact the factory if specific stop settings are required.

Pressure Regulators

## Dimensional Drawing:

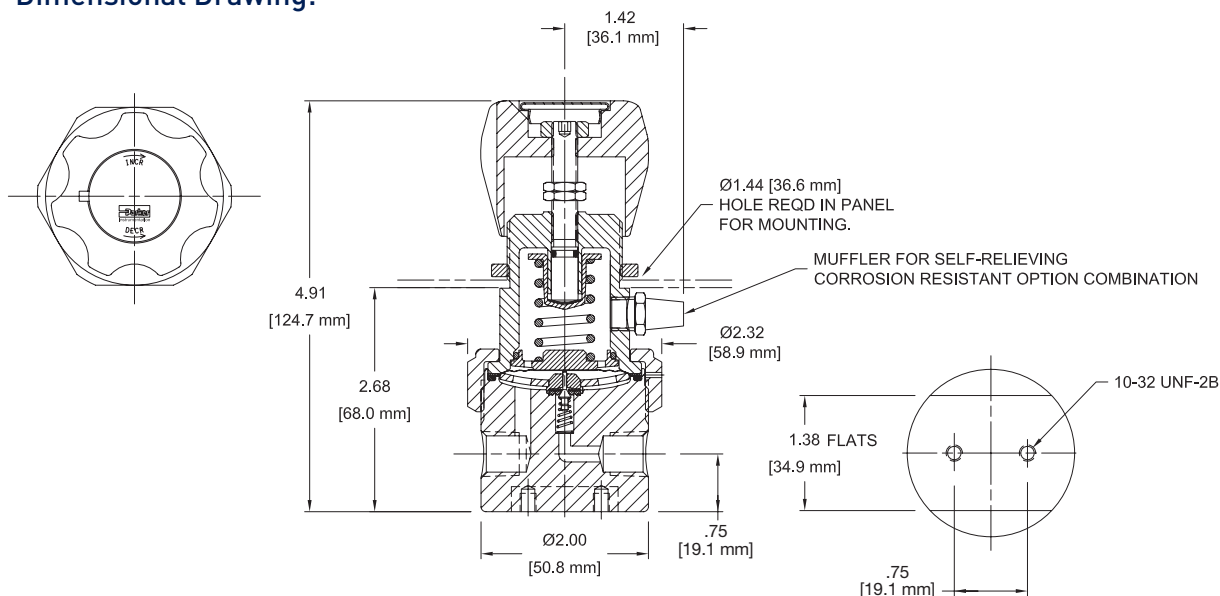

# IR4000 Series

## Ordering Information:

Building a Part Number: <i>Example: IR4002SK4P01304B</i>											
Example Part Number:	IR40	02	S		K	4P	01	30	4	B	
Ordering Parameters/Options:	Regulator	Basic Series	Body Material	Flow Capacity	Seat Material	Porting	Outlet Gauge	Inlet Gauge	Port Style	Port Mounting	Optional Features
Table Reference: (see below)	A	B	C	D	E	F	G	H	I	J	K

A - Regulator	
IR40	IR4000 Series Regulator

B - Basic Series (Range / Outlet Gauge)	
00	0-10 psig / 0-30 psig
01	1-30 psig / 0-60 psig
02	2-60 psig / 0-100 psig
03	3-100 psig / 0-200 psig
04	10-250 psig / 0-400 psig
05	20-500 psig / 0-600 psig

C - Body Material (1)	
S	316L Stainless Steel (Consult factory for Alloy Material options and availability)

D - Flow Capacity	
	0.06 C <sub>v</sub> (std)
1	0.02 C <sub>v</sub>
2	0.15 C <sub>v</sub>

E - Seat Material	
K	PCTFE
P	PEEK™
V	Vespe®

F - Porting	
2P	2 Ports (No X required for gauges, inlet and outlet ports only)
3P	3 Ports (One X for gauge ports)
4P	4 Ports (Two X for gauge ports)
4PB	4 Ports (One X for gauge ports)
5P	5 Ports (Two X for gauge ports)

Note: Ports may be plugged for NPT threaded product.

G - Outlet Gauge / Basic Series	
03	0-30 psig / IR4000
OL	0-60 psig / IR4001
01	0-100 psig / IR4002
2	0-200 psig / IR4003
4	0-400 psig / IR4004
6	0-600 psig / IR4005
X	No Gauge

H - Inlet Gauge	
X	No Gauge
30	3,000 psig (std)
4	400 psig (with 10 psig range)

I - Port Style	
4	1/4" NPT Female (All Gauges ports are 1/4" NPT Female)

J - Port Mounting	
B	0.75 (19.1 mm) port height with 0.75 (19.1 mm) mounting (std)

K - Optional Features (This section can have multiple options)	
C	Corrosion Resistant External (Stainless Steel Cap)
G	Tamper Proof (Not available with D or M option)
M	Metal Knob (Black: Not available with D or G option, required for temps. above 150° F)
L	PTFE Backup O-Ring (PCTFE and PEEK™ Seats only)
S	Self Relieving (Temperature rating -40°F to 150°F (-40°C to 66°C))

Note:  
**Panel Mount Option:** Order Panel Mount Nut Ring (PN: IR4-Panel-Nut-B-NP) as separate line item  
**Vent Muffler Option:** Vent Muffler (PN: Muffler-2F-Bronze) as separate line item.  
 Vent Muffler is standard for the Self Relieving (S), Corrosion Resistant (C) option combination.

Parker Instrumentation Products Division reserves the right to plug NPT ports

Pressure Regulators

# IR5000 Series

## Single-Stage, High Sensitivity Pressure Regulator

Internal Threadless • Stainless Steel



### Value Proposition:

When precise outlet pressure control is a must, Parker's IR5000 Series is the solution. The single-stage, high-sensitivity regulator handles pressures up to 3,500 psig. Corrosion resistance is no problem with its large, convoluted Hastelloy® C-22 diaphragm. Close tolerances and tight alignment of moving components minimize hysteresis and improve cycle life.

### Product Features:

- Unique compression member loads the seal to the body without requiring a threaded nozzle or additional seals
- Internally threadless design reduces particle generation; low internal volume reduces purge times
- Positive upward and downward stops increase cycle life by preventing over stroking of the diaphragm
- Selection of seat materials for media compatibility and temperature applications
- Oxygen cleaned in accordance with ASTM G93 Level C

### Specifications:

Functional Performance	
<b>Design</b>	
Burst Pressure	10,500 psig (724 barg)
Proof Pressure	5,250 psig (362 barg)
<b>Flow Capacity</b>	
C <sub>v</sub> Options	C <sub>v</sub> 0.06 (std), C <sub>v</sub> 0.02, C <sub>v</sub> 0.15
<b>Leak Rate: Internal</b>	Bubble Tight
<b>Leak Rate: External</b>	Bubble Tight
<b>Supply Pressure Effect</b>	Based upon C <sub>v</sub> Option
0.02 C <sub>v</sub>	0.12 psig/100 psig (0.008 barg/7 barg)
0.06 C <sub>v</sub>	0.3 psig/100 psig (0.02 barg/7 barg)
0.15 C <sub>v</sub>	0.75 psig/100 psig (0.05 barg/7 barg)
<b>Internal Volume</b>	19.5 cc without fittings
<b>Approximate Weight</b>	4.5 lbs. (2.1 kg)
Operating Conditions	
Maximum Inlet	Refer to Range Table for specific information
Outlet Options	0 - 5 psig (.3 barg), 1-30 psig (2 barg) 2 - 60 psig (4 barg), 3-100 psig (7 barg) 0-250 psig (17 barg)
<b>Temperature (Standard)</b>	Metal Knob required for temperature above 150°F
PCTFE	-40°F to 150°F (-40°C to 66°C)
PEEK™	-40°F to 272°F (-40°C to 135°C)
VespeI®	-40°F to 500°F (-40°C to 260°C)
Low Pressure IR5000 (P)	-40°F to 150°F (-40°C to 66°C)

Material of Construction	
Wetted	
Body Options	316L Stainless Steel
Compression Member	Inconel® 625
Diaphragm	Hastelloy® C-22
Poppet	Hastelloy® C-22
Poppet Spring	Inconel® X750
Seat Options	PCTFE (std) VespeI® or PEEK™
Carrier Options	316L Stainless Steel (std) or Hastelloy® C-22
Washer Backup Options	316L Stainless Steel (std) or Hastelloy® C-22
O-Ring Backup Options	FKM (std) or PTFE
Inlet Screen/Filter	316 Stainless Steel (std) (60µm mesh screen, 10µm filter)
Non-Wetted	
Cap Options	Nickel Plated Brass or Stainless Steel
Nut	Stainless Steel
Knob Options	ABS (std) (ambient temperature) or Aluminum

For additional information on materials of construction, functional performance and operating conditions, please contact factory.

Hastelloy® C-22 and Hastelloy C-276® are registered trademarks of Haynes International, Inc. PEEK™ is a trademark of Victrex plc. Inconel® and Monel® are registered trademarks of Special Metals Corporation. VespeI® is a registered trademark of DuPont Performance Elastomers L.L.C.

# IR5000 Series

## Flow Curve:

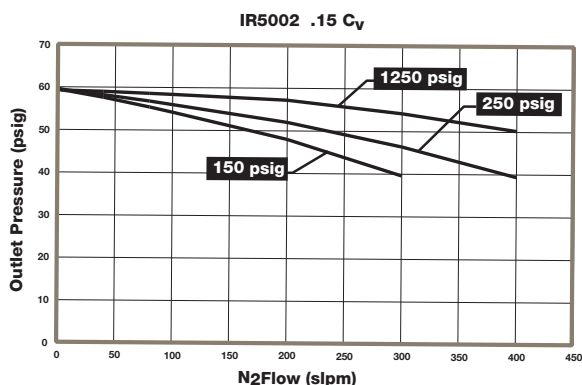
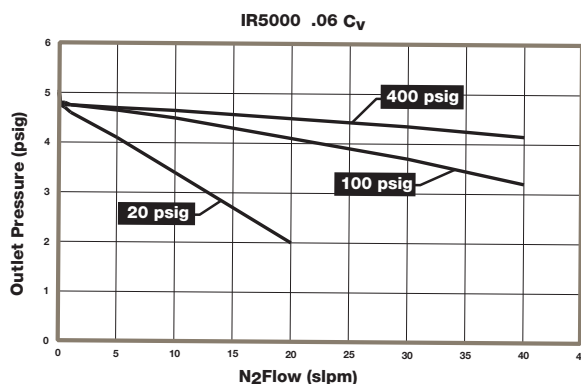
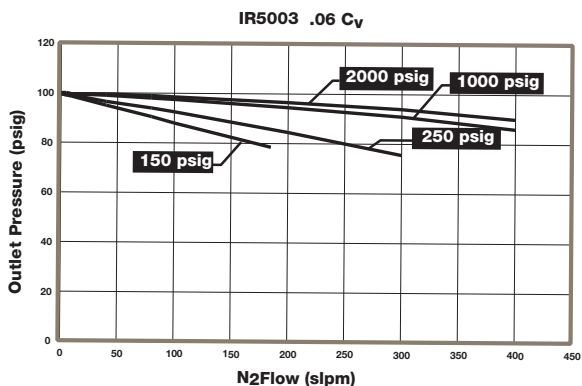

Basic Model	RANGE TABLE		
	Maximum Inlet PSIG		
	0.06 Cv	0.02 Cv	0.15 Cv
IR5000	400	400	400
IR5001	3,500	3,500	1,250
IR5002	3,500	3,500	1,250
IR5003	3,500	3,500	1,250
IR5004	3,500	3,500	1,250

Pressure Regulators

## Dimensional Drawing:

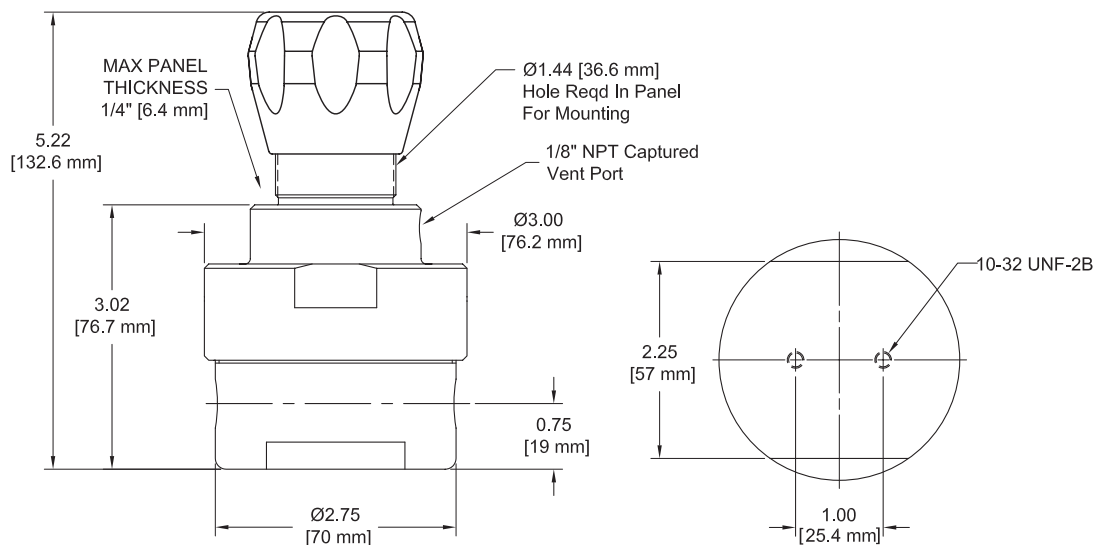

# IR5000 Series

## Ordering Information:

Building a Part Number: *Example: IR5002SK4P01304B*

Example Part Number:	IR50	02	S		K	4P	01	30	4	B	
Ordering Parameters/Options:	Regulator	Basic Series	Body Material	Flow Capacity	Seat Material	Porting	Outlet Gauge	Inlet Gauge	Port Style	Port Mounting	Optional Features
Table Reference: (see below)	A	B	C	D	E	F	G	H	I	J	K

### A - Regulator

IR50	IR5000 Series Regulator
------	-------------------------

### B - Basic Series (Range / Outlet Gauge)

00	0-5 psig (Note: Maximum inlet pressure is 400 psig)
01	1-30 psig
02	2-60 psig
03	3-100 psig
04	10-250 psig

### C - Body Material (1)

S	316L Stainless Steel (Consult factory for Alloy Material options and availability)
---	--

### D - Flow Capacity

	0.06 C <sub>V</sub> (std)
1	0.02 C <sub>V</sub>
2	0.15 C <sub>V</sub>

### E - Seat Material

K	PCTFE
P	PEEK™
V	Vespe <sup>®</sup> (Recommended for Nitrous Oxide (N <sub>2</sub> O) Service)

### F - Porting

2P	2 Ports (No X required for gauges, inlet and outlet ports only)
3P	3 Ports (One X for gauge ports)
4P	4 Ports (Two X for gauge ports)
4PB	4 Ports (One X for gauge ports)

Note: Ports may be plugged for NPT threaded product.

### G - Outlet Gauge / Basic Series

05	0-15 psig / IR5000
OL	0-60 psig / IR5001
01	0-100 psig / IR5002
2	0-200 psig / IR5003
4	0-400 psig / IR5004
X	No Gauge (Gauges may be provided by local Distributor)

### H - Inlet Gauge

X	No Gauge
30	3,000 psig (std)
4	400 psig (with 5 psig range)
20	2,000 psig with the 0.15 C <sub>V</sub> option
40	4,000 psig

### I - Port Style

4	1/4" NPT Female (All Gauges ports are 1/4" NPT Female)
---	--

### J - Port Mounting

B	0.75 (19.1 mm) port height with 1.0 (25.4 mm) mounting (std)
---	--

### K - Optional Features (This section can have multiple options)

C	Corrosion Resistant External (Stainless Steel Cap)
G	Tamper Proof (Not available with D or M option)
L	PTFE Back Up O-ring (PCTFE and PEEK™ Seats Only)
M	Metal Knob (Black: Not available with G option, required for temps. above 150° F)

#### Note:

**Panel Mount Option:** Order Panel Mount Nut Ring (PN: IR4-Panel-Nut-B-NP) as separate line item  
**Vent Muffler Option:** Vent Muffler (PN: Muffler-2F-Bronze) as separate line item.  
 Vent Muffler is standard for the Corrosion Resistant (C) option.

A gas with low molecular weight, such as Hydrogen and Helium, may cause flow vibration.

**Parker Instrumentation Products Division reserves the right to plug NPT ports**

# IR6000 Series

## Two-Stage, General Purpose Pressure Regulator

Internal Threadless • Stainless Steel



### Value Proposition:

With an inlet pressure up to 4,000 psig, Parker's IR6000 two-stage regulator offers high pressure capability with stable pressure control. This general-purpose series features a large, convoluted Hastelloy® diaphragm that provides high corrosion resistance. Close tolerances and tight alignment of moving components minimizes hysteresis and improves cycle life.

### Product Features:

- Unique compression member loads the seal to the body without requiring a threaded nozzle or additional seals
- Internally threadless design reduces particle generation; low internal volume reduces purge times.
- Positive upward and downward stops increase cycle life by preventing over stroking of the diaphragm
- Selection of seat materials for media compatibility and temperature applications
- Oxygen cleaned in accordance with ASTM G93 Level C

### Specifications:

Functional Performance	
<b>Design</b>	
Burst Pressure	12,000 psig (828 barg)
Proof Pressure	6,000 psig (414 barg)
<b>Flow Capacity</b>	
C <sub>v</sub> Options	C <sub>v</sub> 0.06 (std), C <sub>v</sub> 0.02, C <sub>v</sub> 0.15
<b>Leak Rate</b>	
Internal	Bubble Tight
External	Bubble Tight
<b>Supply Pressure Effect</b>	Based upon C <sub>v</sub> Option
0.02 C <sub>v</sub>	0.01 psig/100 psig (0.0007 barg/7 barg)
0.06 C <sub>v</sub>	0.01 psig/100 psig (0.0007 barg/7 barg)
0.15 C <sub>v</sub>	0.02 psig/100 psig (0.001 barg/7 barg)
<b>Internal Volume</b>	8.1 cc without fittings
<b>Approximate Weight</b>	3.5 lbs. (1.6 kg)
Operating Conditions	
Maximum Inlet	Refer to Range Table for specific information
Outlet Options	0 - 10 psig (.7 barg), 1-30 psig (2 barg) 2 - 60 psig (4 barg), 3-100 psig (7 barg) 10-250 psig (17 barg)
<b>Temperature</b>	Metal Knob required for temperature above 150°F
PCTFE	-40°F to 150°F (-40°C to 66°C)
PEEK™	-40°F to 275°F (-40°C to 135°C)
Vespe®	-40°F to 500°F (-40°C to 260°C)
Self-Relieving Option	-40°F to 150°F (-40°C to 66°C)

Material of Construction	
Wetted	
Body Options	316L Stainless Steel (Consult factory for Alloyed Material Availability)
Compression Member	Inconel® 625
Diaphragm	Hastelloy® C-22
Poppet	Hastelloy® C-22
Poppet Spring	Inconel® X750
Seat Options	PCTFE (std) Vespe® or PEEK™
Carrier Options	316L Stainless Steel (std) or Hastelloy® C-22
Washer Backup Options	316 Stainless Steel (std) or Hastelloy® C-22
O-Ring Backup Options	FKM (std) or PTFE
Inlet Screen/Filter	316 Stainless Steel (std) (60µm mesh screen, 10µm filter) (Consult factory for alloyed body material availability)
Self Relieving Seat	PEEK™
Non-Wetted	
Cap Options	Nickel Plated Brass or Stainless Steel
Nut	Stainless Steel
Knob Options	ABS (std) or Aluminum

For additional information on materials of construction, functional performance and operating conditions, please contact factory.

Hastelloy® C-22 and Hastelloy® C-276 are registered trademarks of Haynes International, Inc. PEEK™ is a trademark of Victrex plc. Inconel® and Monel® are registered trademarks of Special Metals Corporation. Vespe® is a registered trademark of DuPont Performance Elastomers L.L.C.

# IR6000 Series

## Flow Curve:

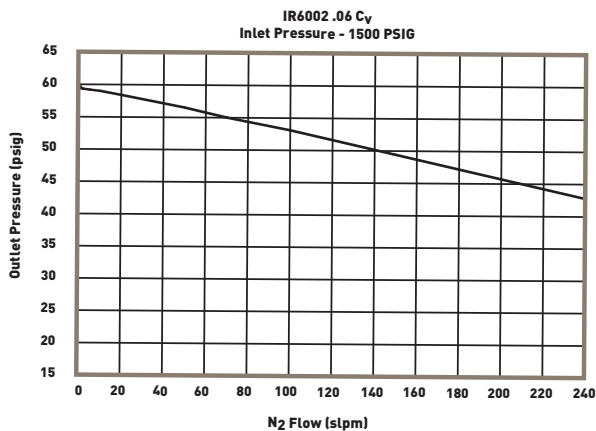
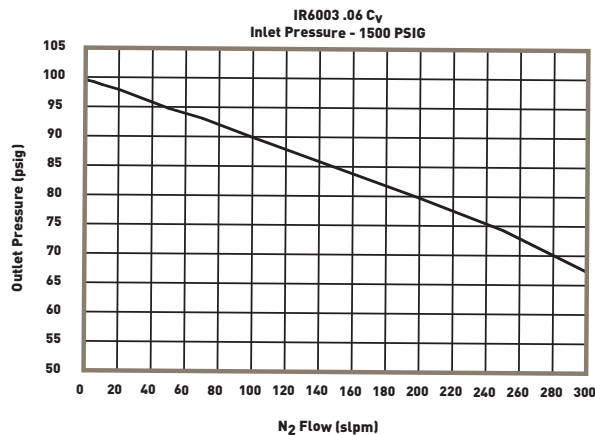
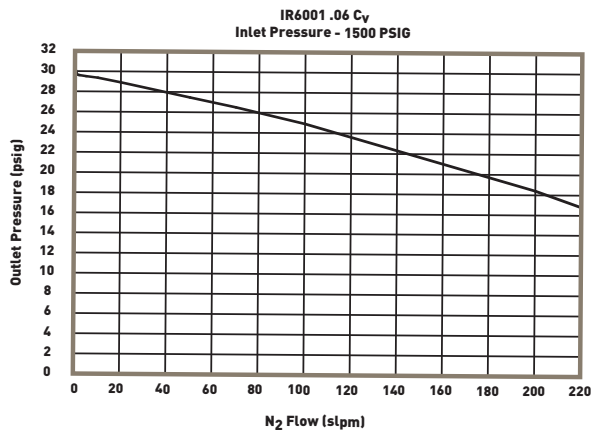

Basic Model	Maximum Inlet PSIG		
	0.06 Cv	0.02 Cv	0.15 Cv
IR6000	4,000	4,000	1,250
IR6001	4,000	4,000	1,250
IR6002	4,000	4,000	1,250
IR6003	4,000	4,000	1,250
IR6004	4,000	4,000	1,250

Pressure Regulators

## Dimensional Drawing:

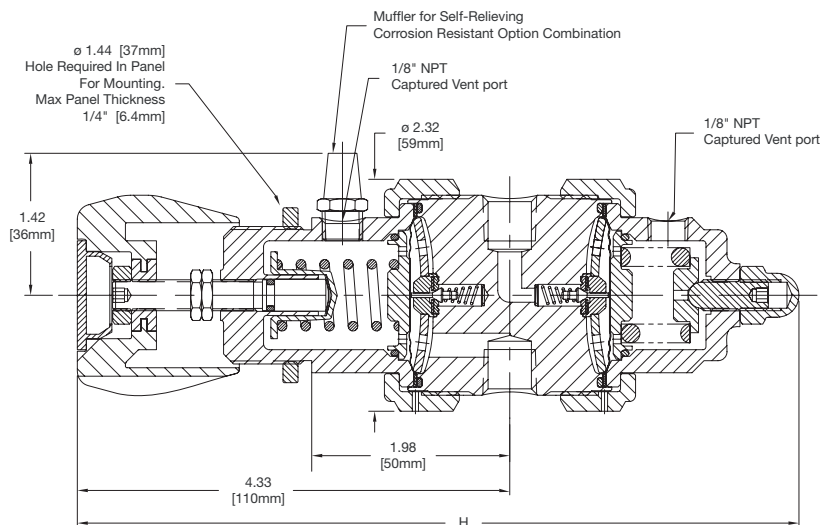

Basic Model	H
IR6000	7.22 (183.4 mm)
IR6001	7.22 (183.4 mm)
IR6002	7.22 (183.4 mm)
IR6003	7.22 (183.4 mm)
IR6004	7.22 (183.4 mm)

# IR6000 Series

## Ordering Information:

Building a Part Number: <i>Example: IR6002SK4P01304BS</i>											
Example Part Number:	IR60	02	S		K	4P	01	30	4	B	S
Ordering Parameters/Options:	Regulator	Basic Series	Body Material	Flow Capacity	Seat Material	Porting	Outlet Gauge	Inlet Gauge	Port Style	Port Mounting	Optional Features
Table Reference: (see below)	A	B	C	D	E	F	G	H	I	J	K

### A - Regulator

IR60	IR6000 Series Regulator
------	-------------------------

### B - Basic Series (Range / Outlet Gauge)

00	0-10 psig
01	1-30 psig
02	2-60 psig
03	3-100 psig
04	10-250 psig

### C - Body Material (1)

S	316L Stainless Steel (Consult factory for Alloy Material options and availability)
---	--

### D - Flow Capacity

	0.06 C <sub>V</sub> (std)
1	0.02 C <sub>V</sub>
2	0.15 C <sub>V</sub>

### E - Seat Material

K	PCTFE
P	PEEK™
V	Vespe <sup>®</sup> (Recommended for Nitrous Oxide (N <sub>2</sub> O) Service)

### F - Porting

2P	2 Ports (No X required for gauges, inlet and outlet ports only)
3P	3 Ports (One X for gauge ports)
4P	4 Ports (Two X for gauge ports)
4PB	4 Ports (One X for gauge ports)
5P	5 Ports (Two X for gauge ports)
6P	6 Ports (Two X for gauge ports)

Note: Ports may be plugged for NPT threaded product.

### G - Outlet Gauge / Basic Series

03	0-30 psig / IR6000
OL	0-60 psig / IR6001
01	0-100 psig / IR6002
2	0-200 psig / IR6003
4	0-400 psig / IR6004
X	No Gauge (Gauges may be provided by local Parker Distributor)

### H - Inlet Gauge

X	No Gauge
30	3,000 psig (std)
20	2,000 psig with the 0.15 C <sub>V</sub> option
40	4,000 psig

### I - Port Style

4	1/4" NPT Female (All Gauges ports are 1/4" NPT Female)
---	--

### J - Port Mounting

B	Standard (No other options)
---	-----------------------------

### K - Optional Features (This section can have multiple options)

C	Corrosion Resistant External (Stainless Steel Cap)
G	Tamper Proof (Not available with M option)
L	PTFE Back Up O-ring (PCTFE and PEEK™ Seats Only)
M	Metal Knob (Black: Not available with G option, required for temps. above 150° F)
S	Self Relieving (Temperature Rating)

**Note:**

**Panel Mount Option:** Order Panel Mount Nut Ring (PN: IR4-Panel-Nut-B-NP) as separate line item

**Vent Muffler Option:** Vent Muffler (PN: Muffler-2F-Bronze) as separate line item.

Vent Muffler is standard for the Self Relieving (S), Corrosion Resistant (C) option combination

**Note:**

A gas with low molecular weight, such as Hydrogen and Helium, may cause flow vibration.

**Parker Instrumentation Products Division reserves the right to plug NPT ports**

# ABP1 Series Back Pressure Regulator

Stainless Steel



## Value Proposition:

Designed with versatility in mind, Parker's ABP1 regulator controls inlet, upstream or back pressure in an instrument or analyzer system. Its materials of construction make it suitable for applications where corrosive media and / or environments are present.

## Product Features:

- Standard Hastelloy C-22® diaphragm for superior strength and corrosion resistance
- Convoluted diaphragm provides outlet pressure stability with changes in flow
- Integral diaphragm stop provides an additional safety measure
- Oxygen cleaned in accordance with ASTM G93 Level C

Pressure Regulators

## Specifications:

Functional Performance	
<b>Design</b>	
Burst Pressure	1,500 psig (103 barg)
Proof Pressure	750 psig (52 barg)
<b>Flow Capacity</b>	
C <sub>v</sub> Options	C <sub>v</sub> 0.3 (std), C <sub>v</sub> 0.1, C <sub>v</sub> 0.06
<b>Leak Rate</b>	
Internal	Bubble Tight
External	Bubble Tight
<b>Internal Volume</b>	5.9 cc
<b>Approximate Weight</b>	2.3 lbs. (1.0 kg)

Operating Conditions	
<b>Control Pressure</b>	1 - 25 psig (2 barg) 2 - 50 psig (3.5 barg) 3 - 100 psig (7 barg) 10 - 250 psig (17 barg) 20 - 500 psig (35 barg)
<b>Maximum Temperature of Flow Media</b>	-15°F to 400°F (-26°C to 204°C) Note: Metal Knob required for high temperature applications

Material of Construction	
Wetted	
Body Options	316L Stainless Steel (std). (Consult factory for alloyed material Options)
Diaphragm	Hastelloy® C-22
Diaphragm Assembly Options	316L Stainless Steel and PTFE (std) or Hastelloy® C-22 and PTFE
Seat Options	PTFE (std.), FKM or FFKM
Seat O-Ring	PTFE
Seat & Holder Options	316L Stainless Steel (std) or Hastelloy® C-22
Outboard Gasket	PTFE
Screen Options	316L Stainless Steel (std) or Hastelloy® C-22
Non-Wetted	
Cap	303 Stainless Steel
Cap Nut	316L Stainless Steel
Knob Options	ABS (std) or Aluminum

For additional information on materials of construction, functional performance and operating conditions, please contact factory.

Hastelloy® C-22 is a registered trademark of Haynes International, Inc.

# ABP1 Series

## Flow Curve:

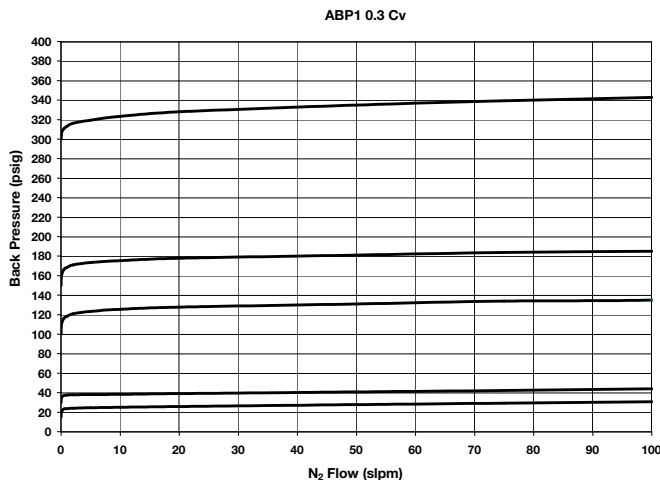

## Dimensional Drawing:

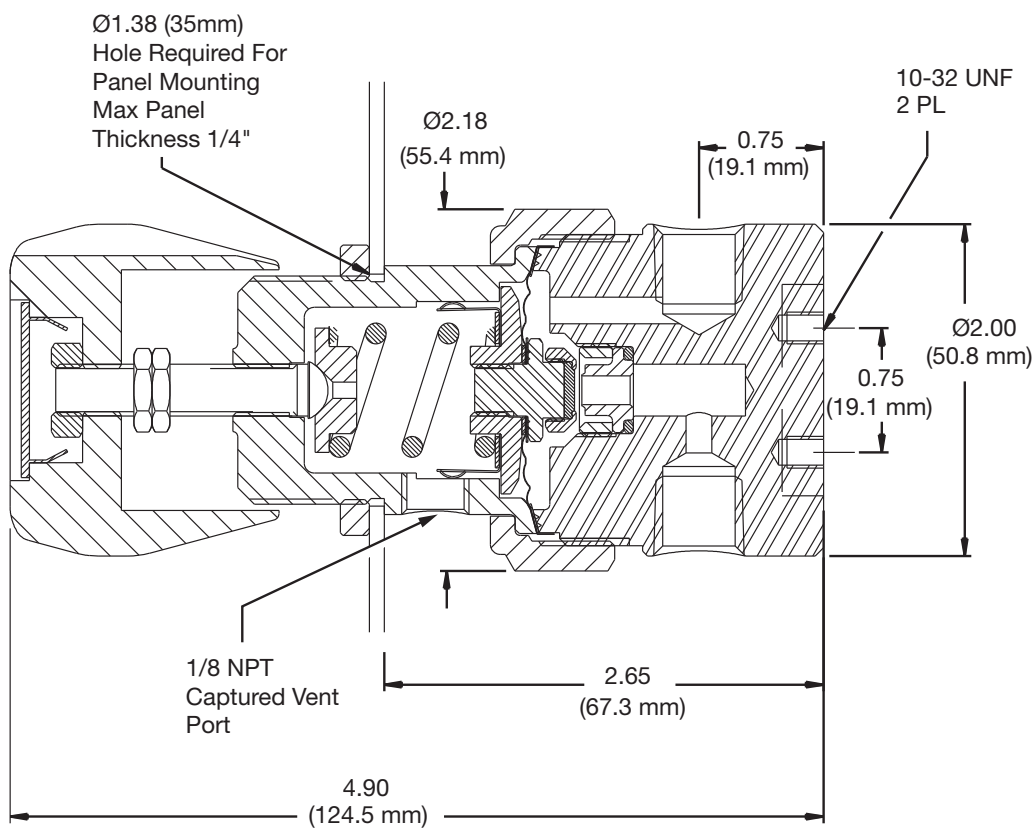

Pressure  
Regulators

# ABP1 Series

## Ordering Information:

Building a Part Number: *Example: ABP1ST33BP24*

Example Part Number:	ABP1	S	T	3	3BP	X	4	
Ordering Parameters/Options:	Series	Body Material	Seal Material	Pressure Range	Porting	Inlet Gauge	Port Style	Optional Features
Table Reference: (see below)	A	B	C	D	E	F	G	H

A - Series	
ABP1	ABP1 Series Regulator

B - Body Material	
S	316L Stainless Steel (Consult factory for Alloy Material options)

C - Seal Material	
T	PTFE
V	Fluorocarbon Elastomer (FKM)
K	Perfluoroelastomer (FFKM)

D - Pressure Range	
1	1-25 psig
2	2-50 psig
3	3-100 psig
4	10-250 psig
5	20-500 psig

E - Porting	
2BP	2 Ports (No X required for gauges, inlet and outlet ports only)
3BP	3 Ports (One X for gauge port)
3PB	3 Ports (One X for gauge port, outlet through bottom)
3PP	3 Ports (One X for gauge port)

F - Inlet Gauge	
03	0-30 psig
OL	0-60 psig
2	0-200 psig
4	0-400 psig
6	0-600 psig
X	No gauge (Gauges may be provided by local Parker Distributor)

G - Port Style	
4	1/4" NPT Female (All Gauge ports are 1/4" NPT Female)

H - Optional Features	
M	Metal Knob (Black)
06	0.06 C <sub>v</sub>
1	0.1 C <sub>v</sub>

**Note:**

**Panel Mount Option:**  
Order Panel Mount Nut Ring (PN: IR4-Panel-Nut-B-NP) as separate line item

**Vent Muffler Option:**  
Vent Muffler (PN: Muffler-2F-Bronze) as separate line item.

**Parker Instrumentation Products Division reserves the right to plug NPT ports**

Pressure Regulators

## Port Configuration:

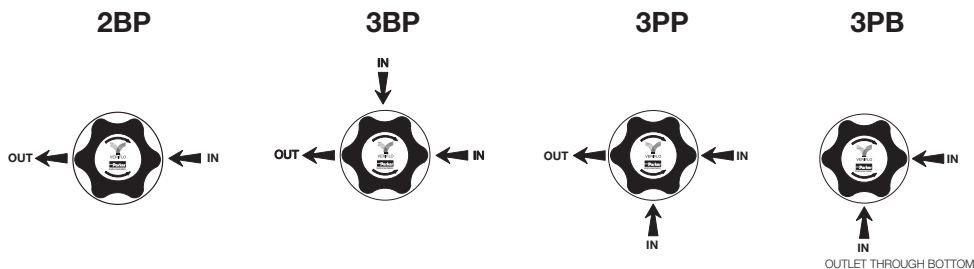

# ABP3 Series Back Pressure Regulator

High Sensitivity • Stainless Steel



## Value Proposition:

Designed with versatility in mind, the ABP3 Series regulator offers precise control of inlet, upstream, or back pressure. Its large, convoluted diaphragm ensures greater sensitivity of outlet pressures. Standard Hastelloy® diaphragm construction makes it ideal for harsh applications where corrosive media / environments are present.

## Product Features:

- Standard Hastelloy® C-22 diaphragm for superior strength and corrosion resistance
- Convoluted diaphragm provides outlet pressure stability with changes in flow
- Integral diaphragm stop provides an additional safety measure
- Oxygen cleaned in accordance with ASTM G93 Level C

## Specifications:

Functional Performance	
<b>Design</b>	
Burst Pressure	180 psig (12.4 barg)
Proof Pressure	90 psig (6 barg)
<b>Flow Capacity</b>	
C <sub>v</sub> Options	C <sub>v</sub> 0.3 (std), C <sub>v</sub> 0.1, C <sub>v</sub> 0.06
<b>Leak Rate</b>	
Internal	Bubble Tight
External	Bubble Tight
<b>Internal Volume</b>	13.8cc
<b>Approximate Weight</b>	4.2 lbs. (1.9 kg)

Operating Conditions	
<b>Control Pressure</b>	1 - 5 psig (0.07-0.3 barg) 1 - 30 psig (0.07-2.06 barg) 2 - 60 psig (0.2-4.1 barg)
<b>Maximum Temperature of Flow Media</b>	-15°F to 400°F (-26°C to 204°C) Note: Metal Knob required for high temperature applications

Material of Construction	
Wetted	
Body Options	316L Stainless Steel (std). (Consult factory for alloyed Material Options)
Diaphragm	Hastelloy® C-22
Diaphragm Assembly Options	316L Stainless Steel and PTFE (std) or Hastelloy® C-22 and PTFE
Seat O-Ring	PTFE
Seat & Holder Options	316L Stainless Steel (std) or Hastelloy® C-22
Seal Options	PTFE (std.), FKM or FFKM
Outboard O-Ring Options	PTFE (with PTFE or FFKM seats) FKM (with FKM seats)
Screen Options	316L Stainless Steel (std) or Hastelloy® C-22
Non-Wetted	
Cap	Nickel Plated Brass
Cap Nut	Nickel Plated Brass
Knob Options	ABS (std) or Aluminum

For additional information on materials of construction, functional performance and operating conditions, please contact factory.

Hastelloy® is a registered trademark of Haynes International, Inc.

# ABP3 Series

## Flow Curve:

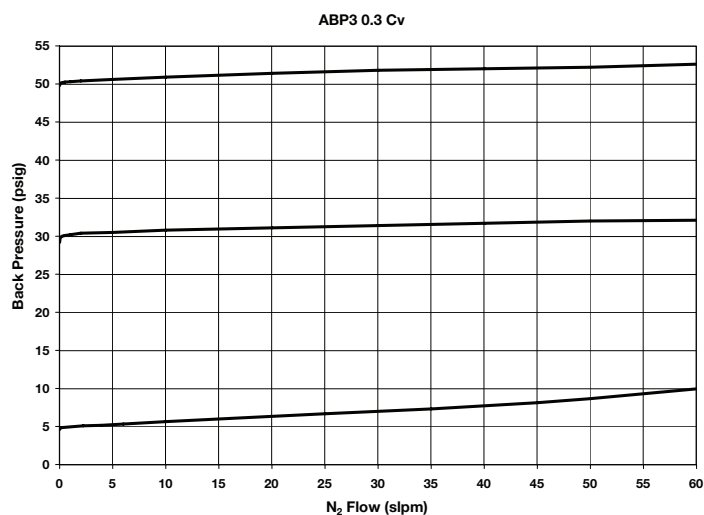

## Dimensional Drawing:

Pressure Regulators

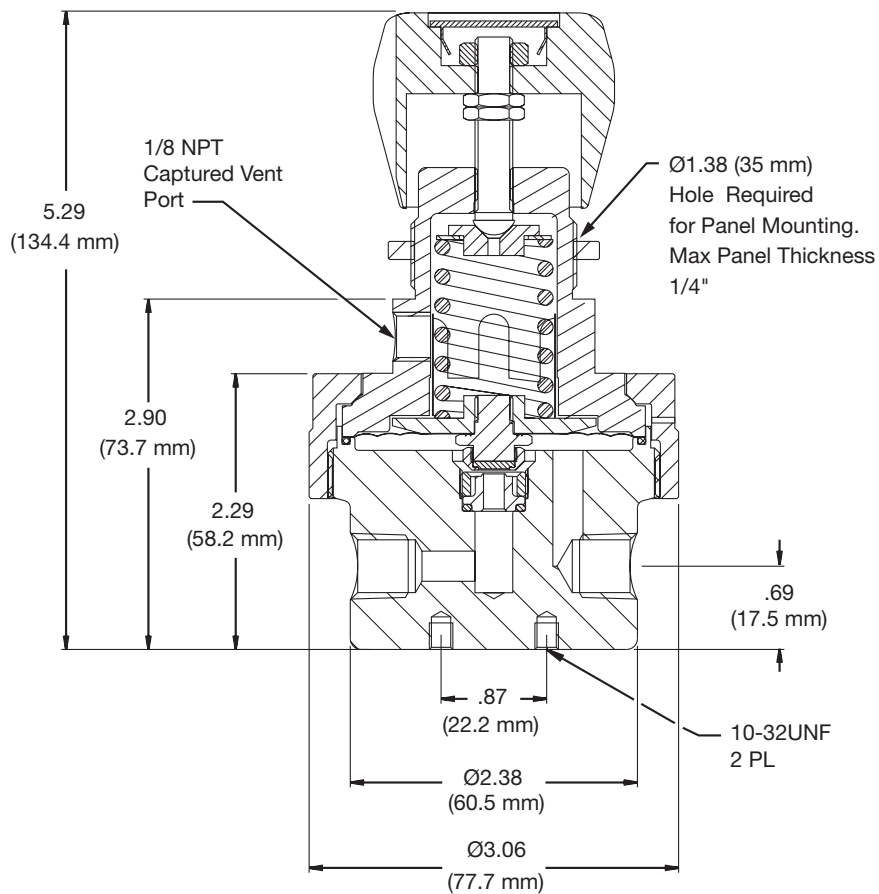

# ABP3 Series

## Ordering Information:

Building a Part Number: <i>Example: ABP3ST33BPX4</i>								
Example Part Number:	ABP3	S	T	3	3BP	X	4	
Ordering Parameters/Options:	Series	Body Material	Seal Material	Pressure Range	Porting	Inlet Gauge	Port Style	Optional Features
Table Reference: (see below)	A	B	C	D	E	F	G	H

A - Series	
ABP3	ABP3 Series Regulator

B - Body Material	
S	316L Stainless Steel (Consult factory for Alloy Material options)

C - Seal Material	
T	PTFE
V	Fluorocarbon Elastomer (FKM)
K	Perfluoroelastomer (FFKM)

D - Pressure Range	
1	1-5 psig
2	1-30 psig
3	2-60 psig

E - Porting	
2BP	2 Ports (No X required for gauges, inlet and outlet ports only)
3BP	3 Ports (One X for gauge port)
3PP	3 Ports (One X for gauge port)

F - Inlet Gauge	
05	0-15 psig
OL	0-60 psig
01	0-100 psig
X	No gauge (Gauges may be provided by local Parker Distributor)

G - Port Style	
4	1/4" NPT Female (All Gauge ports are 1/4" NPT Female)

H - Optional Features	
M	Metal Knob (Black)
06	0.06 C <sub>v</sub>
1	0.1 C <sub>v</sub>

**Note:**

**Panel Mount Option:**  
Order Panel Mount Nut Ring (PN: IR4-Panel-Nut-B-NP) as separate line item

**Vent Muffler Option:**  
Vent Muffler (PN: Muffler-2F-Bronze) as separate line item.

**Parker Instrumentation Products Division reserves the right to plug NPT ports**

Pressure Regulators

## Port Configuration:

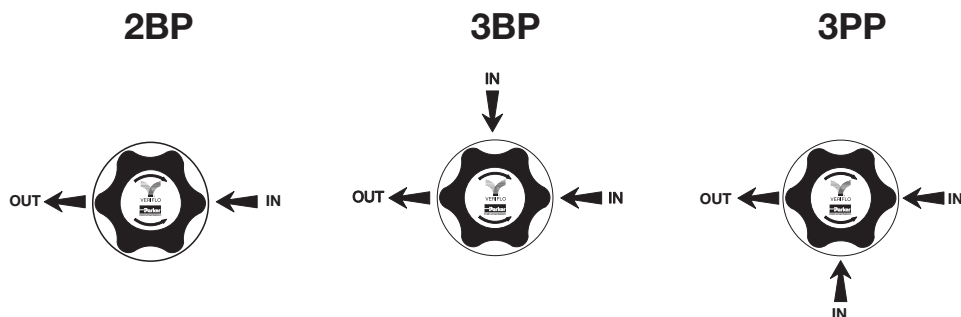

# BPR50 Series

## High Pressure, Back Pressure Regulator

Gas and Liquid Service • Stainless Steel



### Value Proposition:

Capable of withstanding corrosive media and environments, Parker's BPR50 piston-style back pressure regulator controls upstream or back pressure. Suitable for non-corrosive liquids and gases at pressures up to 2,000 psig.

### Product Features:

- 316L Stainless Steel construction
- Gas or liquid service
- Simple construction makes maintenance easy
- Panel mount option is available
- Adjustable pressures from 100-1,200 psig and 200-2,000 psig
- Flow coefficient of 0.45 C<sub>v</sub>
- Oxygen cleaned in accordance with ASTM G93 Level C

Pressure Regulators

### Specifications:

Functional Performance	
<b>Design</b>	
Burst Pressure	6,000 psig (414 barg)
Proof Pressure	3,000 psig (207 barg)
<b>Flow Capacity</b>	
C <sub>v</sub>	C <sub>v</sub> 0.45
<b>Leak Rate</b>	
Internal	Bubble Tight
External	Bubble Tight
Maximum Liquid Flow	20 lpm (5 gpm)
Hysteresis	20 psig (1.4 barg)
Sensitivity	0.5 psig (0.03 barg)
<b>Internal Volume</b>	5 cc
<b>Approximate Weight</b>	2.2 lbs. (1.0kg)

Operating Conditions	
Control Pressure	100-1,000 psig (7-83 barg) 200-2,000 psig (14-138 barg)
Temperature	-40°F to 150°F (-40°C to 66°C)

Material of Construction	
Wetted	
Body Options	316L Stainless Steel
Seat Options	Glass Filled PTFE or PCTFE
Seal Holder	316L Stainless Steel
O-Ring Options	FKM (std) or FFKM
Piston	316L Stainless Steel
Gasket	PCTFE
Spring	316L Stainless Steel

Non-Wetted	
Cap	Nickel Plated Brass
Broach Stem	316L Stainless Steel
T Bar Handle	Nickel Plated Brass

For additional information on materials of construction, functional performance and operating conditions, please contact factory.

# BPR50 Series

Flow Curve:

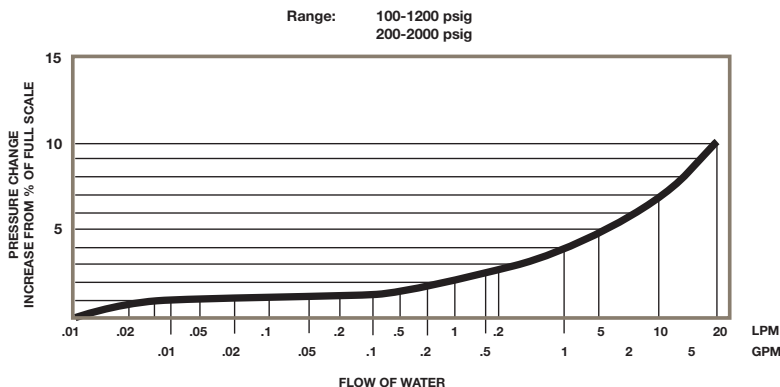

Dimensional Drawing:

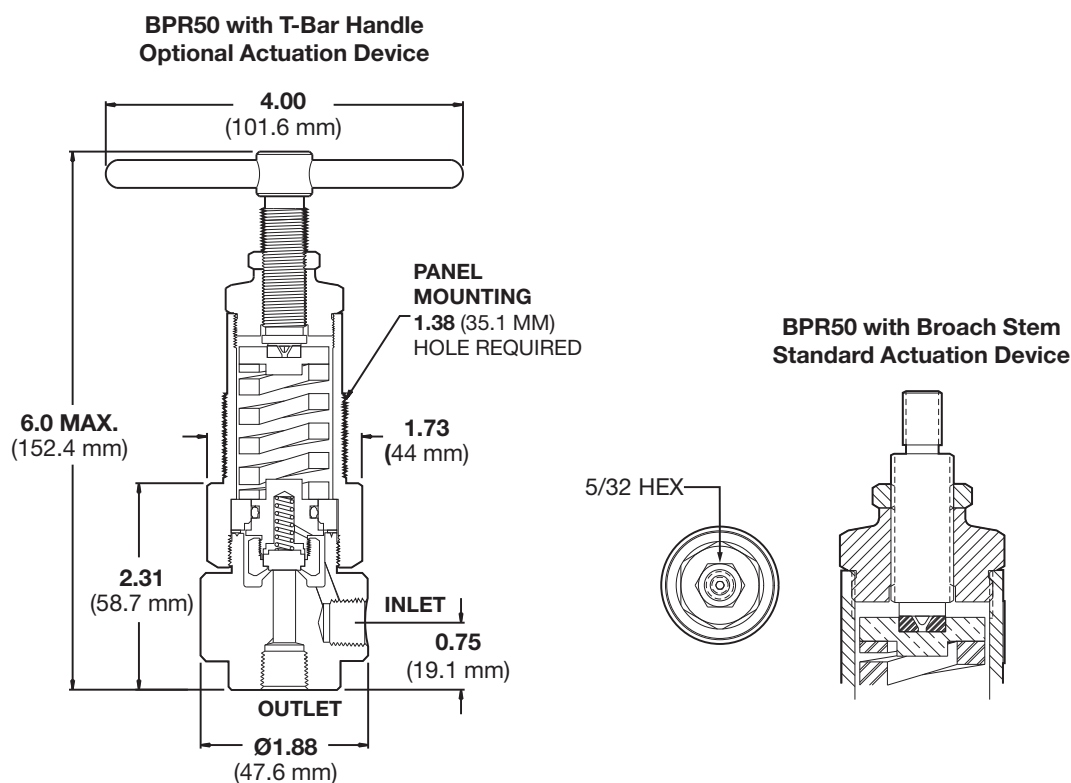

Pressure  
Regulators

# BPR50 Series

## Ordering Information:

Building a Part Number: *Example: BPR50S3PB1BHPM*

Example Part Number:	BPR50	S	3PB	1	BH	PM
Ordering Parameters/Options:	Regulator	Body Material	Porting	Adjustment Range	Actuation Device	Optional Features
Table Reference: (see below)	A	B	C	D	E	F

### A - Regulator

BPR50	BPR50 Series Regulator
-------	------------------------

### B - Body Material

S	316L Stainless Steel
---	----------------------

### C - Porting

2PB	2 Ports (Outlet through bottom)
3BP	3 Ports
3PB	3 Ports (Outlet through bottom)

### D - Adjustment Range

1	100-1,200 psig
2	200-2,000 psig

### E - Actuation Device

BH	T Bar Handle
	Broach Stem (std)

### F - Optional Features (This section can have multiple options)

K	Perfluoroelastomer (FFKM) O-ring with PCTFE Seal
PM	Panel Mount

**Note:** All inlet and outlet ports are 1/4" FNPT  
Parker Instrumentation Products Division reserves the right to plug NPT ports

Pressure Regulators

## Porting Configurations:

### 2PB



OUTLET THROUGH BOTTOM

### 3BP

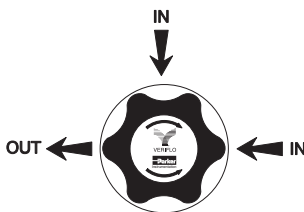

### 3PB

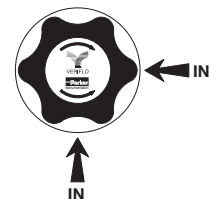

OUTLET THROUGH BOTTOM

# AVR3 Series

## Steam Heated, Vaporizing Pressure Regulator

Pressure Reducing • Stainless Steel

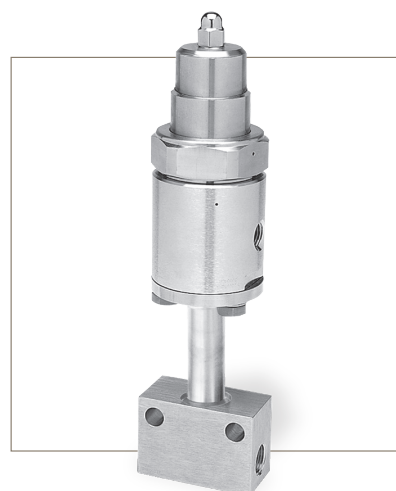

### Value Proposition:

The AVR3 Series regulator is designed to heat and/or vaporize a gas or liquid sample before entering an analyzer system. The unique design allows the user to disassemble the regulator and heat transfer components for complete cleaning and repair of the unit, thus reducing expensive replacement costs and down time.

### Product Features:

- Ultra low internal volume
- Convuluted Hastelloy® C-22 diaphragm for superior strength and corrosion resistance provides outlet pressure stability with changes in flow
- Field-serviceable heat transfer element
- Integral diaphragm stop provides additional measure of safety

### Specifications:

Functional Performance	
<b>Design</b>	
Burst Pressure	10,500 psig (724 barg)
Proof Pressure	5,250 psig (362 barg)
<b>Flow Capacity</b>	C <sub>v</sub> 0.06 Nominal
<b>Leak Rate:</b> Internal	Bubble Tight
<b>Leak Rate:</b> External	Bubble Tight
<b>Internal Volume</b>	
High Pressure Inlet	0.57 cc
Overall	4.6 cc
<b>Approximate Weight</b>	8 lbs. (2.0 kg)

Operating Conditions	
Maximum Inlet	3,500 psig (241 barg) or 250 psig (17.2 barg) for 10 psig range
Outlet Options	0-10 psig (0.7 barg), 1-30 psig (2 barg) 2-60 psig (4 barg), 3-100 psig (7 barg) 10-250 psig (17 barg) , 20-500 psig (35 barg)
<b>Temperature</b>	Based upon seat option
PCTFE	150°F (66°C)
PEEK™	275°F (135°C)
Vespel®	500°F (260°C)
Maximum Steam Supply	600 psig, 500°F (41barg, 260°C)

Material of Construction	
Wetted	
Body Options	316L Stainless Steel (std) (Consult factory for alloyed body material availability)
Compression Member	Inconel® 625
Diaphragm	Hastelloy® C-22
Poppet	Hastelloy® C-22
Poppet Spring	Inconel® X750
Seat Options	PCTFE (std), PEEK™ or Vespel®
Carrier Options	316L Stainless Steel (std) or Hastelloy® C-22
Heater Seal	PEEK™
O-ring Backup	FKM
Non-Wetted	
Nut	316L Stainless Steel
Cap	303 Stainless Steel

For additional information on materials of construction, functional performance and operating conditions, please contact factory.

Hastelloy C-22® and Hastelloy C-276® are registered trademarks of Haynes International, Inc. PEEK™ is a trademark of Victrex plc. Inconel® and Monel® are registered trademarks of Special Metals Corporation. Vespel® is a registered trademark of DuPont Performance Elastomers L.L.C.

# AVR3 Series

## Flow Curve:

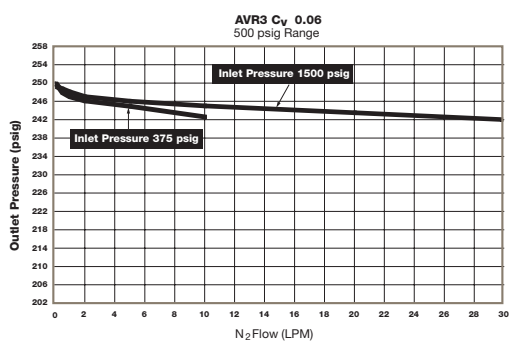
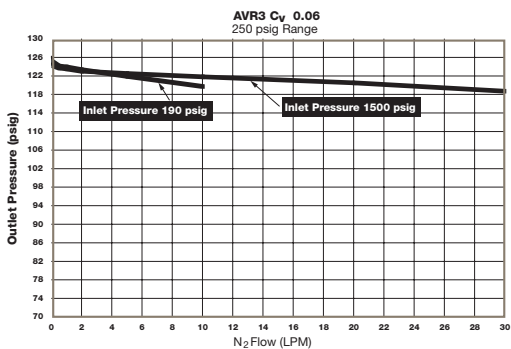

## Porting Configurations:

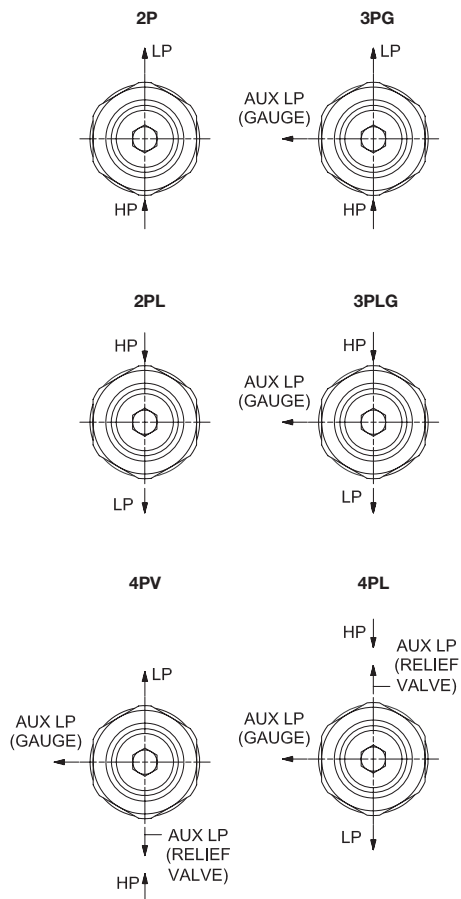

## Dimensional Drawing: (AVR3S shown)

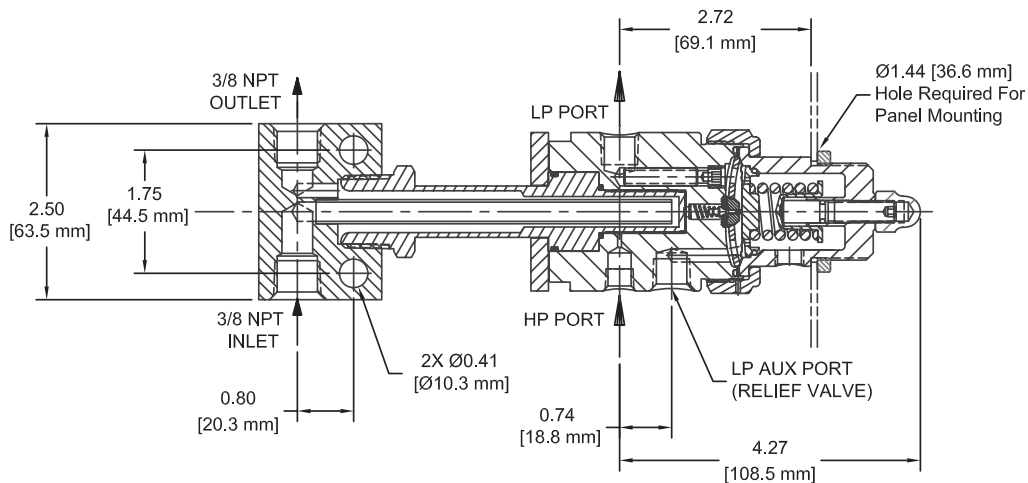

# AVR3 Series

## Ordering Information:

Building a Part Number: <i>Example: AVR3SK1X3PG</i>						
Example Part Number:	<b>AVR3</b>	<b>S</b>	<b>K</b>	<b>1</b>	<b>X</b>	<b>3PG</b>
Ordering Parameters/Options:	Series	Body Material	Seat Material	Pressure Range	Outlet Gauge	Porting Configuration
Table Reference: (see below)	<b>A</b>	<b>B</b>	<b>C</b>	<b>D</b>	<b>E</b>	<b>F</b>

A - Series	
AVR3	AVR3 Series Pressure Regulator

B - Body Material	
S	316L Stainless Steel

C - Seat Material	
K	PCTFE
P	PEEK™
V	VespeI®

D - Pressure Range	
0	0-10 psig (Maximum inlet 250 psig)
1	1-30 psig
2	2-60 psig
3	3-100 psig
4	10-250 psig
5	20-500 psig

E - Outlet Gauge	
03	0-30 psig
OL	0-60 psig
01	0-100 psig
4	0-400 psig
6	0-600 psig
X	No Gauge

F - Porting Configuration	
Blank	2 Port
3PG	3 Port
4PV	4 Port
2PL	2 Port (Reverse Entry)
3PLG	3 Port
4PL	4 Port

Additional configurations available upon request

**Notes:**

Parker IPD reserves the right to plug NPT ports.  
High pressure port standard is 1/8" NPT Female.  
1/4" NPT Female on auxiliary outlet ports.

Parker Instrumentation Products Division reserves the right to plug NPT ports

Pressure Regulators

### AVR3S

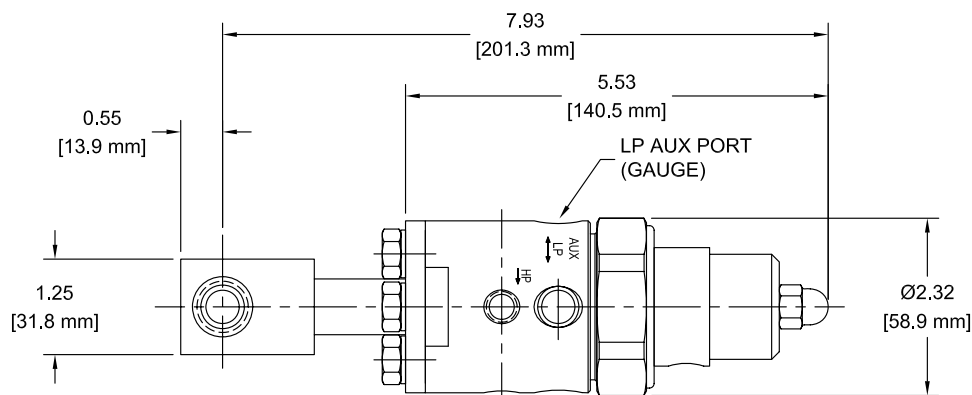

# AVR4 Series

## Electrically Heated, Vaporizing Pressure Regulator

Pressure Reducing • Stainless Steel



### Value Proposition:

The Parker AVR4 Series regulator is engineered to heat and/or vaporize a gas or liquid sample before entering an analyzer system. Its unique design allows users to disassemble the regulator and heat transfer components for complete cleaning and repair of the unit, thus reducing expensive replacement costs and downtime.

### Product Features:

- Ultra low internal volume
- CSA, CE-ATEX certified
- Convoluted Hastelloy® C-22 diaphragm for superior strength and corrosion resistance provides outlet pressure stability with changes in flow
- Field-serviceable heat transfer element
- TCO (Thermal cut-out) is standard for all heat ranges
- Integral diaphragm stop provides additional measure of safety valves / 250 psig for manual and AOPLPNC valves

### Specifications:

Functional Performance	
<b>Design</b>	
Burst Pressure	10,500 psig (724 barg)
Proof Pressure	5,250 psig (362 barg)
<b>Flow Capacity</b>	C <sub>v</sub> 0.06 Nominal
<b>Leak Rate: Internal</b>	Bubble Tight
<b>Leak Rate: External</b>	Bubble Tight
<b>Internal Volume</b>	3.29 cc
High Pressure Inlet	0.57 cc
Overall	4.6 cc
<b>Approximate Weight</b>	8 lbs. (2.0 kg)

Electrical Conditions	
Power Requirements	120V or 240V, 50/60 Hz
Heater Wattage	40, 100, 150 or 200 watt
Temperature Controller (Proportional)	75°F to 220°F or 215°F to 380°F (24°C to 105°C or 102°C to 194°C) Ranges are Approximate
Condulet	Crouse Hinds, UL and CSA listed Class 1, Groups A, B, C, D Class 2, Groups E, F, G

For additional information on materials of construction, functional performance and operating conditions, please contact factory.

Hastelloy® C-22 and Hastelloy® C-276 are registered trademarks of Haynes International, Inc. PEEK™ is a trademark of Victrex plc. Inconel® and Monel® are registered trademarks of Special Metals Corporation. Vespel® is a registered trademark of DuPont Performance Elastomers L.L.C. SilcoNert™ 1000 is a trademark of SilcoTek Corporation.

Operating Conditions	
Operating Pressure	3,500 psig (241 barg) or 250 psig (17.2 barg) for 10 psig range
Outlet Options	0-10 psig (0.7 barg), 1-30 psig (2 barg) 2-60 psig (4 barg), 3-100 psig (7 barg) 10-250 psig (17 barg) , 20-500 psig (35 barg)
<b>Temperature</b>	Based upon seat option
PCTFE	150°F (66°C)
PEEK™	275°F (135°C)
Vespel®	500°F (260°C)
Ambient Temperature	-4°F to 104°F (-20°C to 40°C)

Material of Construction	
Wetted	
Body Options	316L Stainless Steel (std) (Consult factory for alloyed body material availability)
Compression Member	Inconel® 625
Diaphragm	Hastelloy® C-22
Poppet	Hastelloy® C-22
Poppet Spring	Inconel® X750
Seat Options	PCTFE (std), PEEK™ or Vespel®
Carrier Options	316L Stainless Steel (std) or Hastelloy® C-22
Heater Seal	PEEK™
O-ring Backup	FKM
Non-Wetted	
Nut	303 Stainless Steel
Cap	17-4 PH
Condulet	Cast iron Alloy and Aluminum

# AVR4 Series

## Flow Curve:

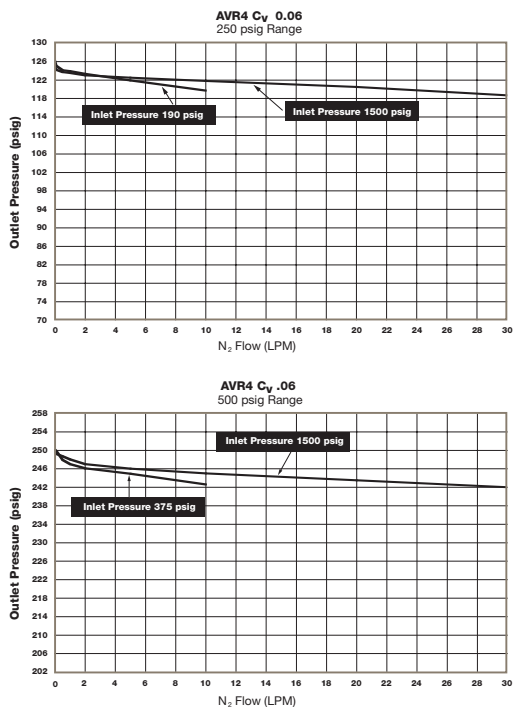

## Porting Configurations:

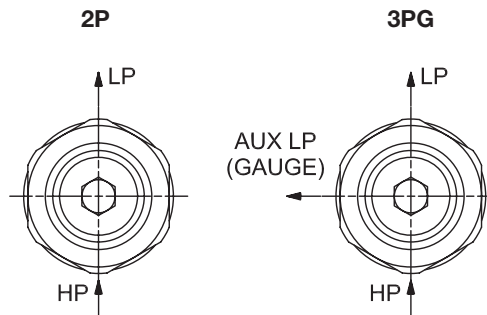

## Dimensional Drawing:

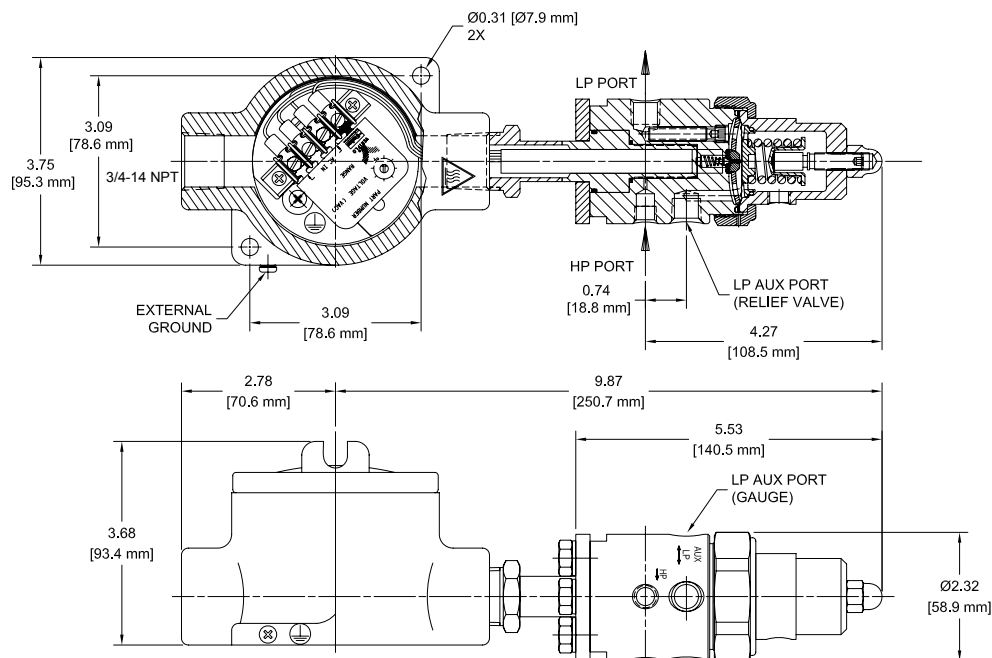

Pressure Regulators

# AVR4 Series

## Ordering Information:

Building a Part Number: *Example: AVR4SK1120DLX3PG*

Example Part Number:	AVR4	S	K	1	120	D	L	X	3PG	
Ordering Parameters/Options:	Series	Body Material	Seat Material	Pressure Range	Voltage	Heater Wattage	Temperature Controller	Outlet Gauge	Porting Configuration	Optional Features
Table Reference: (see below)	A	B	C	D	E	F	G	H	I	J

### A - Series

AVR4	AVR4 Series Pressure Regulator
------	--------------------------------

### B - Body Material

S	316L Stainless Steel
---	----------------------

### C - Seat Material

K	PCTFE
P	PEEK™
V	Vespel®

### D - Pressure Range

0	0-10 psig (Maximum inlet 250 psig)
1	1-30 psig
2	2-60 psig
3	3-100 psig
4	10-250 psig
5	20-500 psig

### E - Voltage

120	120V
240	240V

### F - Heater Wattage

D	150
E	200

### G - Temperature Controller

L	75°F to 200°F (24°C to 104°C)
H	200°F to 380°F (104°C to 193°C) - (Only available in 120V)

### H - Outlet Gauge

03	0-30 psig
OL	0-60 psig
01	0-100 psig
4	0-400 psig
6	0-600 psig
X	No Gauge

### I - Porting Configuration

Blank	2 Port
3PG	3 Port High pressure port standard is 1/8" NPT Female. 1/4" NPT Female on auxiliary outlet ports.

### J - Optional Features

RTK	SilcoNert™ 1000 Coating in wetted metallic components only. Does not include gauges or relief valves
-----	--

Parker Instrumentation Products Division reserves the right to plug NPT ports

Product rated for operation in Hazardous Areas:

FM/CSA Class I Div. II

ATEX Zone II

Check with factory for certification details

# APR66 Series

## Single-Stage, High-Pressure Regulator

Pressure Reducing • Stainless Steel



### Value Proposition:

The Parker APR66 is a high pressure-reducing, single-stage regulator designed to operate at inlet pressures up to 6,000 psig. A full range of pressure sensing can be achieved without time-consuming spring and piston changeouts.

### Product Features:

- Piston Sensing
- Thrust bearing allows low actuating torque and precise setability
- Low friction adjusting screw sleeve provides smooth operation
- Optional self-relieving feature allows user to decrease outlet pressure in closed systems. Feature is actuated by turning the adjusting knob counterclockwise
- Oxygen cleaned in accordance with ASTM G93 Level C

### Specifications:

Functional Performance	
<b>Design</b>	
Burst Pressure	18,000 psig (1,241 barg)
Proof Pressure	9,000 psig (620 barg)
<b>Flow Capacity</b>	
C <sub>v</sub> Options	C <sub>v</sub> 0.05
<b>Leak Rate: Internal</b>	Bubble Tight
<b>Leak Rate: External</b>	Bubble Tight
<b>Supply Pressure Effect</b>	100-1000 psig (4 psig/100 psig (0.28 barg/7 barg) 100-2000 psig (4 psig/100 psig (0.28 barg/7 barg) 100-3000 psig (4 psig/100 psig (0.28 barg/7 barg) 100-6000 psig (6 psig/100 psig (0.4 barg/7 barg)
<b>Approximate Weight</b>	3.0 lbs. (1.4 kg)

Operating Conditions	
Maximum Inlet	6,000 psig (414 barg)
Outlet Options	100 - 1000 psig (69 barg) 100 - 2000 psig (138 barg) 100 - 3000 psig (207 barg) 100 - 6000 psig (414 barg)
Maximum Temperature of Flow Media	-40°F to 165°F (-40°C to 74°C) Note: Metal Knob required for high temperature applications

Material of Construction	
Wetted	
Body Options	316L Stainless Steel (std).
Poppet	316L Stainless Steel
Spring	Hastelloy® C-22
Seat	PEEK™
Seat & Screw Clamp	316L Stainless Steel
Plug & Screw	316L Stainless Steel
Piston	Torlon®
Piston Housing	316L Stainless Steel
Stem	316L Stainless Steel
Seals	Aflas®, PTFE and PCTFE
Non-Wetted	
Cap	Nickel Plated Brass
Nut	316L Stainless Steel
Knob Options	ABS (std) or Aluminum

For additional information on materials of construction, functional performance and operating conditions, please contact factory.

Hastelloy® is a registered trademark of Hayes International, Inc.  
Aflas® is a registered trademark of 3M Company.  
PEEK™ is a trademark of Victrex plc.  
Torlon® is a registered trademark of Solvay Specialty Polymers.

# APR66 Series

## Flow Curve:

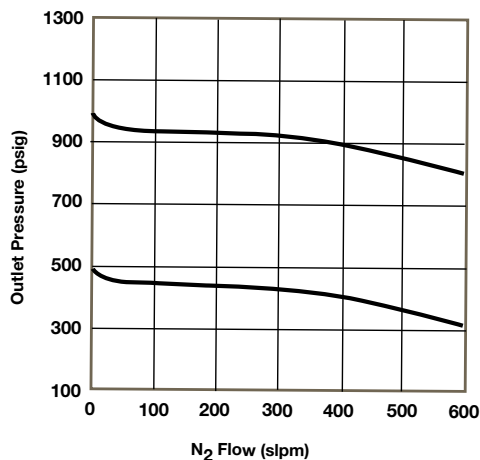

## Dimensional Drawing:

Pressure Regulators

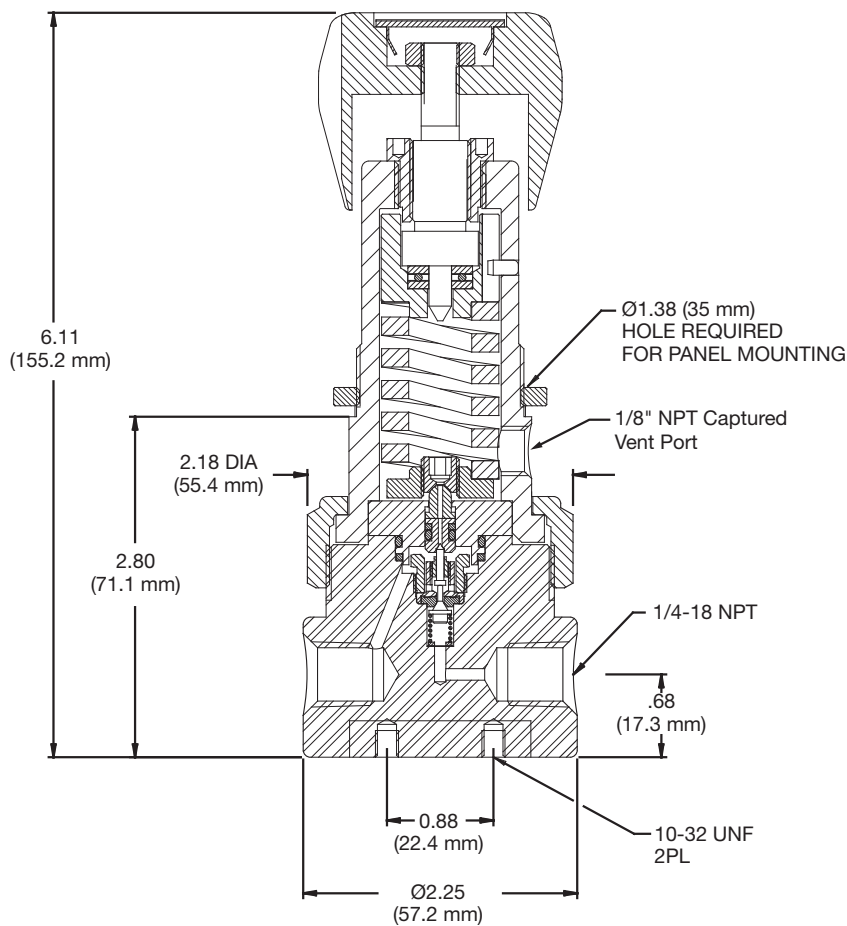

# APR66 Series

## Ordering Information:

Building a Part Number: <i>Example: APR66S4P1XX4M</i>								
Example Part Number:	APR66	S	4P	1	X	X	4	M
Ordering Parameters/Options:	Series	Body Material	Porting	Pressure Range	Outlet Gauge	Inlet Gauge	Port Style	Optional Features
Table Reference: (see below)	A	B	C	D	E	F	G	H

A - Series	
APR66	APR66 Series Regulator

B - Body Material	
S	316L Stainless Steel

C - Porting	
2P	2 Ports (No X required for gauges, inlet & outlet ports only)
3P	3 Ports (One X for gauge port)
4P	4 Ports (Two X's for gauge ports)

D - Pressure Range	
1	100-1000 psig
2	100-2000 psig
3	100-3000 psig
4	100-6000 psig

E - Outlet Gauge	
20	0-2000 psig
30	0-3000 psig
40	0-4000 psig
60	0-6000 psig
X	No Gauge (Gauges may be provided by local Parker Distributor)

F - Inlet Gauge (Gauges may be provided by local Parker Distributor)	
40	0-4000 psig
60	0-6000 psig
X	No Gauge

G - Port Style	
4	1/4" NPT Female (All Gauges are 1/4" NPT Female)

H - Optional Features	
M	Metal Knob (Black)
SR	Self-Relieving (For safety purposes, the optional self-relieving feature is not recommended for toxic or flammable gasses or liquids.)

Note:  
Each unit is standard with a threaded cap and panel mount nut.  
**Parker Instrumentation Products Division reserves the right to plug NPT ports**

Pressure Regulators

# HPR800 Series

## Single-Stage, High Pressure Regulator

Low Acting Torque • Stainless Steel



### Value Proposition:

For applications requiring high outlet pressures up to 2,500 psig, the HPR800 Series delivers. Its diaphragm-actuated design means fewer seals exposed to the media than a piston-actuated regulator.

### Product Features:

- Low actuating torque
- Diaphragm sensing regulator
- Self-contained valve seat assembly
- Fluid media capabilities: Corrosive and non-corrosive gases
- Easily maintained
- Maximum inlet of 5,000 psig
- Oxygen cleaned in accordance with ASTM G93 Level C

Pressure Regulators

### Specifications:

Functional Performance	
<b>Design</b>	
Burst Pressure	15,000 psig (1034 barg)
Proof Pressure	7,500 psig (517 barg)
<b>Flow Capacity</b>	
C <sub>v</sub> Options	C <sub>v</sub> 0.02
<b>Leak Rate</b>	
Internal	Bubble Tight
External	Bubble Tight
Supply Pressure Effect	0.5 psig/100 psig (0.03 barg/7 barg)
<b>Internal Volume</b>	6.5 cc
<b>Approximate Weight</b>	2.19 lbs. (0.993 kg)

Operating Conditions	
Maximum Inlet	5,000 psig @70°F (345 barg @ 21°C)
For Oxygen	3,000 psig (206.9 barg)
Outlet Options	10 - 800 psig (0-2 barg) 20 - 1,500 psig (1.4-103 barg) 50 - 2,500 psig (3.4-172 barg)
<b>Temperature</b>	-40°F to 150°F (-40°C to 66°C)

Material of Construction	
Wetted	
Body Options	316L Stainless Steel
Diaphragm	316L Stainless Steel, PTFE Lined
Gasket	PCTFE
<b>Nozzel Assembly</b>	
Nozzel Body Options	316L Stainless Steel
Filter	316L Stainless Steel
Poppet Options	316L Stainless Steel
Poppet Spring	Inconel® 600
Seat	PCTFE
Retaining Ring	15-7 PH
Non-Wetted	
Spring Housing Options	Nickel Plated Brass
Bushing	Nickel Plated Brass
Stem Handle Tee Options	Nickel Plated Brass

For additional information on materials of construction, functional performance and operating conditions, please contact factory.

Inconel® and Monel® are registered trademarks of Special Metals Corporation.

# HPR800 Series

## Flow Curve:

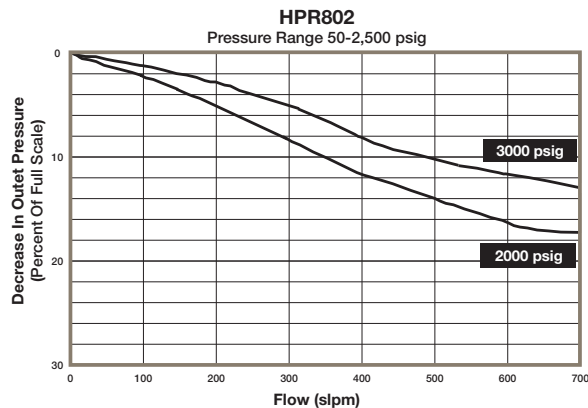
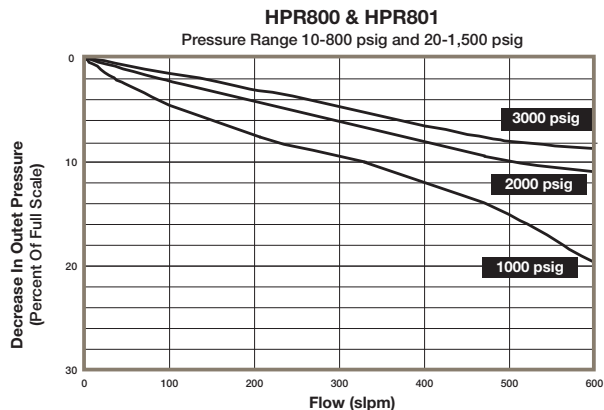

## Dimensional Drawing:

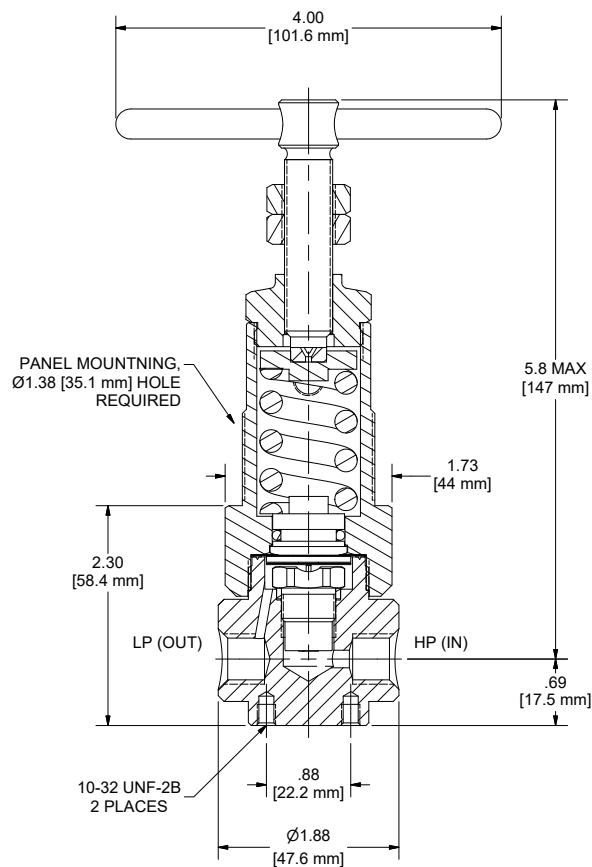

Pressure  
Regulators

# HPR800 Series

## Ordering Information:

Building a Part Number: *Example: HPR801S3P104*

Example Part Number:	<b>HPR80</b>	<b>1</b>	<b>S</b>	<b>3P</b>	<b>10</b>		<b>4</b>	
Ordering Parameters/Options:	Series	Range	Body Material	Porting	Outlet Gauge	Inlet Gauge	Port Style	Optional Features
Table Reference: (see below)	<b>A</b>	<b>B</b>	<b>C</b>	<b>D</b>	<b>E</b>	<b>F</b>	<b>G</b>	<b>I</b>

### A - Series

HPR800	HPR800 Series Regulator
--------	-------------------------

### B - Range

0	10-800 psig
1	20-1,500 psig
2	50-2,500 psig

### C - Body Material

S	316L Stainless Steel (Consult factory for Alloy Material options and availability)
---	--

### D - Porting

2P	2 Ports (No X required for gauges, inlet and outlet ports only)
3P	3 Ports (One X for gauge ports)
4P	4 Ports (Two X for gauge ports)
5P	5 Ports (Two X for gauge ports)

### E - Outlet Gauge

10	0-1,000 psig
20	0-2,000 psig
30	0-3,000 psig
X	No Gauge

### F - Inlet Gauge

30	0-3,000 psig
40	0-4,000 psig
60	0-6,000 psig
X	No Gauge

### G - Port Style

4	1/4" NPT Female (All Gauges ports are 1/4" NPT Female)
---	--

### I - Optional Features (This section can have multiple options)

PM	Panel Mount
----	-------------

Note:

Parker Instrumentation Products Division reserves the right to plug NPT ports

# HFR900 Series

## Single-Stage, High Flow Pressure Regulator

Stainless Steel



### Value Proposition:

The HFR900 Series is designed for high flow rates requiring a compact pressure regulator for control. It can be used with corrosive and non-corrosive gases. Meets most high flow requirements with less than 500 psig supply pressure.

### Product Features:

- Self-contained, replaceable valve seat assembly
- Over 20 years of proven reliability
- Available in 316L Stainless Steel
- 1/8" NPT captured vent port is standard
- Large orifice for high flow (up to 500 LPM)
- Large diaphragm for higher sensitivity
- Panel Mount option available
- Oxygen cleaned in accordance to ASTM G93 Level C

### Specifications:

Functional Performance	
<b>Design</b>	
Burst Pressure	1,500 psig (103 barg)
Proof Pressure	750 psig (52 barg)
<b>Flow Capacity</b>	C <sub>v</sub> 0.85
<b>Leak Rate</b>	
Internal	Bubble Tight
External	Bubble Tight
<b>Internal Volume</b>	38 cc without fittings
<b>Approximate Weight</b>	2.5 lbs. (1.2 kg)

Operating Conditions	
Maximum Inlet	Based upon seat option
Fluorocarbon	500 psig (35 barg)
Perfluoroelastomer	200 psig (14 barg)
Outlet Options	1 - 30 psig (0-2 barg) 2 - 75 psig (0.1-5 barg) 5 - 150 psig (0.3-10 barg)
<b>Temperature</b>	-40°F to 150°F (-40°C to 66°C)

Material of Construction	
Wetted	
Body	316L Stainless Steel
Diaphragm	316L Stainless Steel, PTFE Lined
<b>Nozzel Assembly</b>	
Nozzel Body Options	316L Stainless Steel
Seat Options	(K) Perfluoroelastomer (FFKM) or (V) Fluorocarbon (FKM)
Screen	316L Stainless Steel
Retaining Ring	15-7 PH
Gasket	PTFE
Washer	316L Stainless Steel
Spring	316 Stainless Steel
Non-Wetted	
Cap Options	Nickel Plated Brass
Knob	ABS

For additional information on materials of construction, functional performance and operating conditions, please contact factory.

Specialty Regulators

# HFR900 Series

## Flow Curve:

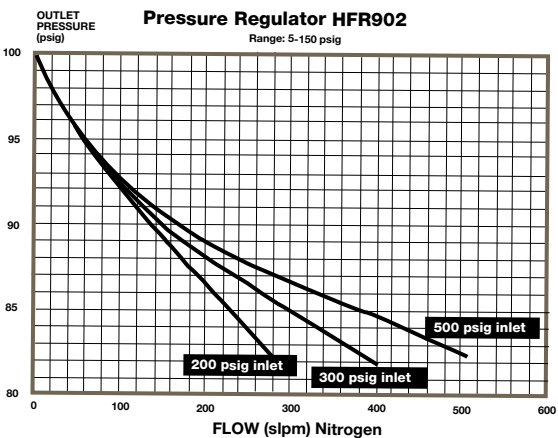
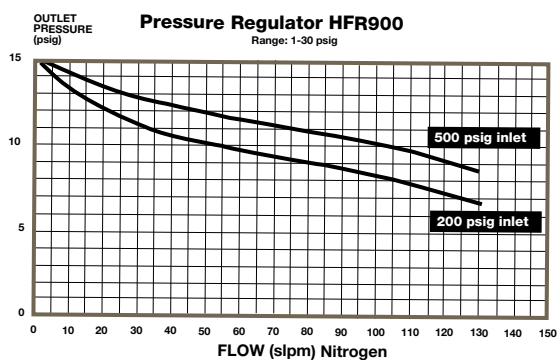
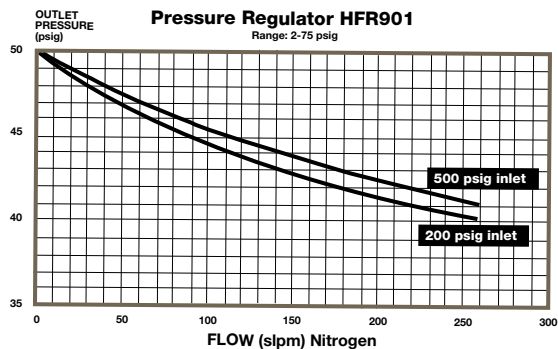
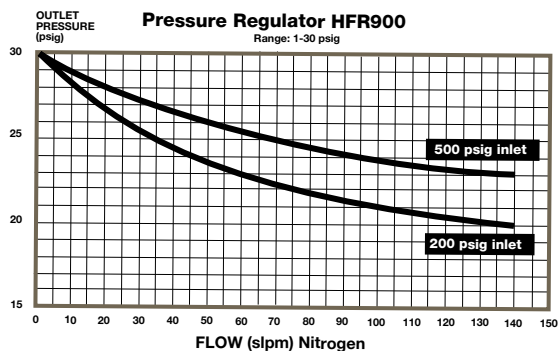

Specialty Regulators

## Dimensional Drawing:

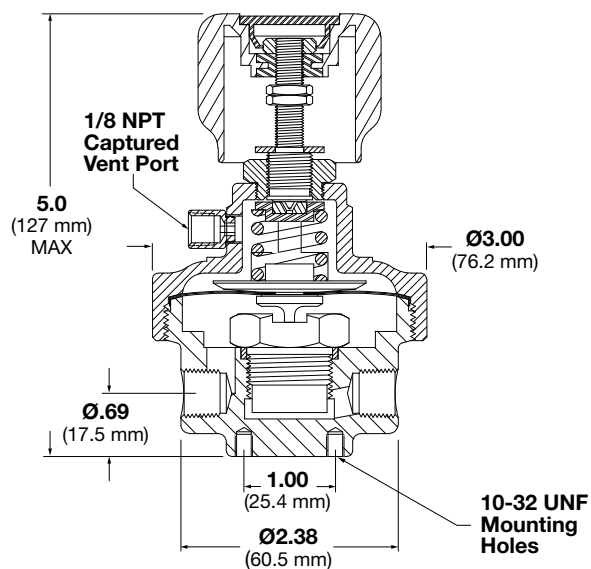

# HFR900 Series

## Ordering Information:

Building a Part Number: <i>Example: HFR900S4P0346K</i>									
Example Part Number:	HFR90	0	S	4P	03	4	6	K	
Ordering Parameters/Options:	Series	Range	Body Material	Porting	Outlet Gauge	Inlet Gauge	Port Style	Seat Material	Optional Features
Table Reference: (see below)	A	B	C	D	E	F	G	H	I

A - Series	
HFR90	HFR900 Series Regulator

B - Range	
0	0-30 psig
1	2-75 psig
2	5-150 psig

C - Body Material	
S	316L Stainless Steel

D - Porting	
2P	2 Ports (No X required for gauges, inlet and outlet ports only)
3P	3 Ports (One X for gauge ports)
4P	4 Ports (Two X for gauge ports)
4PB	4 Ports (One X for gauge ports)

Note: Ports may be plugged for NPT threaded product.

E - Outlet Gauge / Basic Series	
03	0-30 psig
OL	0-60 psig
01	0-100 psig
2	0-200 psig
X	No Gauge

F - Inlet Gauge	
4	0-400 psig
6	0-600 psig
X	No Gauge

G - Port Style	
4	1/4" NPT Female (All Gauge ports are 1/4" NPT Female)
6	3/8" NPT Female (All Gauge ports are 1/4" NPT Female)
8	1/2" NPT Female (All Gauge ports are 1/4" NPT Female)

H - Seat Material	
K	Perfluoroelastomer (FFKM) (200 psig maximum)
V	Fluorocarbon (FKM) (500 psig maximum)

I - Optional Features (This section can have multiple options)	
PM	Panel Mount (Captured Vent Not Available)

Parker Instrumentation Products Division reserves the right to plug NPT ports

Specialty Regulators

# 735 Series

## Two-Stage, Tied Diaphragm Regulator

High Pressure • Stainless Steel



### Value Proposition:

The two-stage, tied diaphragm design of Parker's 735 Series regulator provides constant outlet pressure regardless of inlet pressure fluctuations. Corrosive or hazardous gases are shut off in the event a leak across the seat occurs. Unique compression member loading eliminates threads in the wetted area, thus reducing particle entrapment.

### Product Features:

- Tied Diaphragm for added safety
- Unique compression member loads the seal to body eliminating threads in the wetted area
- Metal-to-metal diaphragm-to-body seal assures high leak integrity

### Specifications:

Specialty Regulators

Functional Performance	
<b>Design</b>	
Burst Pressure	10,500 psig (724 barg)
Proof Pressure	5,250 psig (362 barg)
<b>Flow Capacity</b>	
C <sub>v</sub> Options	C <sub>v</sub> 0.04
<b>Leak Rate</b>	
Internal	Bubble Tight
External	Bubble Tight
<b>Supply Pressure Effect</b>	
0.04 C <sub>v</sub>	0.2 psig/100 psig (0.01 barg/7 barg)
<b>Internal Volume</b>	10.10 cc without fittings
<b>Approximate Weight</b>	3.5 lbs. (1.6 kg)

Operating Conditions	
Maximum Inlet	3,500 psig (240 barg)
Outlet Options	1 - 30 psig (2 barg) 3 - 100 psig (7 barg)
<b>Temperature</b>	-40°F to 150°F (-40°C to 66°C)

Material of Construction	
Wetted (see Note 3 on Page 3)	
Body Options	316L Stainless Steel (std)
Compression Member	316L Stainless Steel
Diaphragm Options	316L Stainless Steel and Hastelloy C-22®
Poppet Options	316L Stainless Steel
Poppet Spring Options	Inconel X750®
Poppet Screen	316L Stainless Steel
Seat Options	PCTFE (std) or Vespel®
Carrier Options	316L Stainless Steel (std) or Hastelloy C-22®
Inlet Screen	316 Stainless Steel
Non-Wetted	
Cap Options	Nickel Plated Brass
Nut	316L Stainless Steel
Knob	ABS

For additional information on materials of construction, functional performance and operating conditions, please contact factory.

A-LOK® is a registered trademark of Parker Hannifin Corporation.  
Hastelloy C-22® and Hastelloy C-276® are registered trademarks of Haynes International, Inc.  
PEEK™ is a trademark of Victrex plc.  
Inconel® and Monel® are registered trademarks of Special Metals Corporation.  
Vespel® is a registered trademark of DuPont Performance Elastomers L.L.C.

# 735 Series

## Flow Curve:

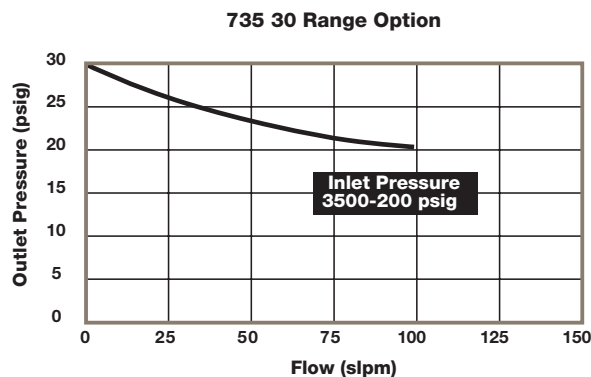
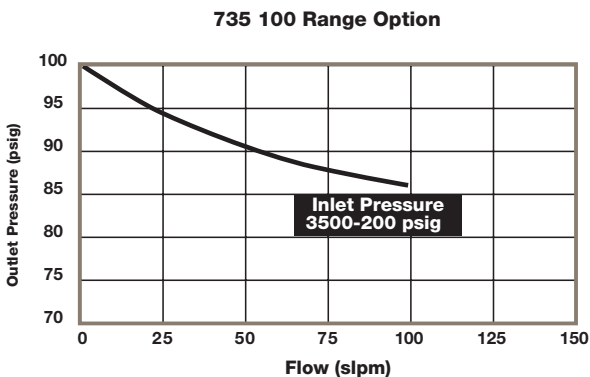

*These tests were performed using Nitrogen at ambient conditions.*

## Dimensional Drawing:

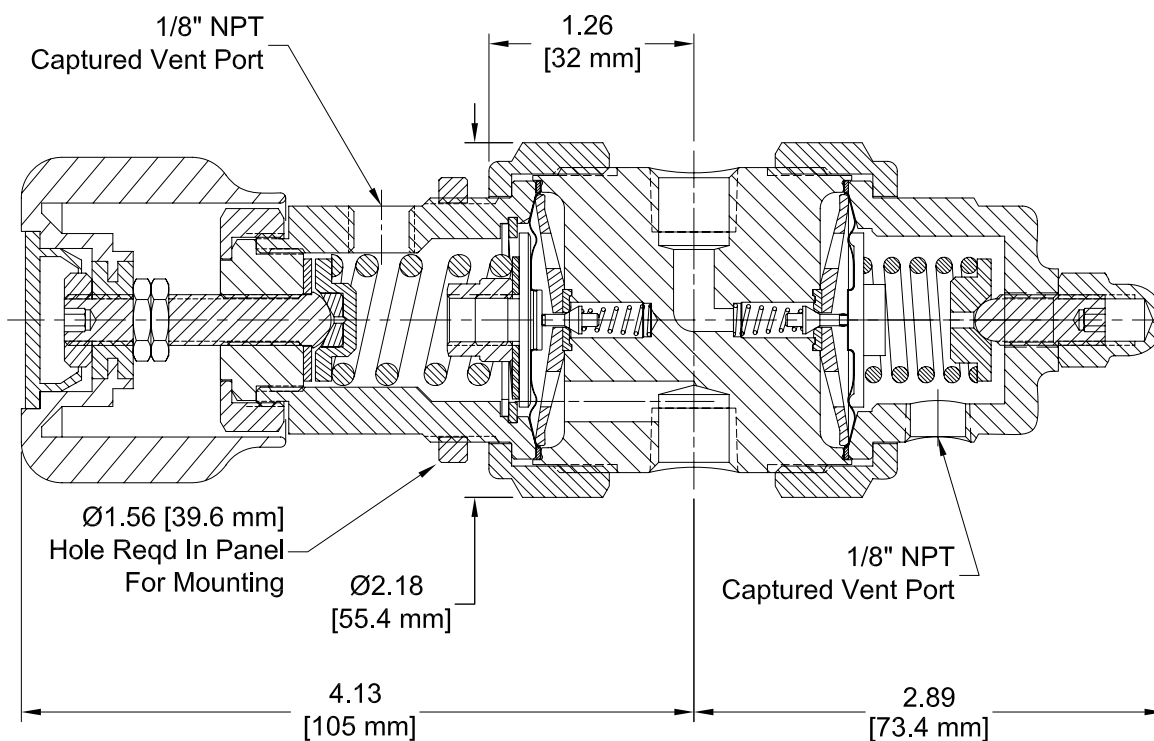

Specialty Regulators

# 735 Series

## Ordering Information:

Building a Part Number: <i>Example: 73530S4POL304PM</i>								
Example Part Number:	735	30	S	4P	OL	30	4	PM
Ordering Parameters/Options:	Regulator	Range	Body Material	Porting	Outlet Gauge	Inlet Gauge	Port Style	Optional Features
Table Reference: (see below)	A	B	C	D	E	F	G	H

A - Regulator	
735	735 Series Regulator

B - Range	
30	1-30 psig
100	3-100 psig

C - Body Material (1)	
S	316L Stainless Steel (consult factory for Alloy Material options and availability)

D - Porting	
2P	2 Ports (No X required for gauges, inlet and outlet ports only)
3P	3 Ports (One X for gauge ports)
4P	4 Ports (Two X for gauge ports)
5P	5 Ports (One X for gauge ports)
7P	7 Ports (Two X for gauge ports)
See Regulator Porting Guide for additional options and port layouts	

E - Outlet Gauge / Basic Series	
03	0-30 psig
OL	0-60 psig
01	0-100 psig
X	No Gauge

F - Inlet Gauge	
X	No Gauge
30	3,000 psig
4	400 psig
40	4,000 psig

G - Port Style	
4	1/4" NPT Female (All Gauges ports are 1/4" NPT Female)

H - Optional Features (This section can have multiple options)	
PM	Panel Mount
VESP	Vespe <sup>l</sup> ® Seat (Recommended for N <sub>2</sub> O service)

For additional information on materials of construction, functional performance and operating conditions, please contact factory.

Hastelloy<sup>®</sup> C-22 and Hastelloy<sup>®</sup> C-276 are registered trademarks of Haynes International, Inc. Vespe<sup>l</sup>® is a registered trademark of DuPont Performance Elastomers L.L.C.

**Parker Instrumentation Products Division reserves the right to plug NPT ports**

Specialty Regulators

# NPR4100 Series Negative Pressure Regulator

Stainless Steel



## Value Proposition:

The NPR4100 Series regulator offers negative delivery pressures with the use of low pressure gas sources. This regulator is specifically designed to regulate negative pressures down to -26 in. Hg vacuum (100 Torr). Close tolerances and tight alignment of moving components minimize hysteresis and improve cycle life. Convolved, Hastelloy C-22® diaphragm provides high corrosion resistance and increases cycle life.

## Product Features:

- Unique compression member loads the seal to the body without requiring a threaded nozzle or additional seals
- Internally threadless design reduces particle generation The low internal volume reduces purge times.
- The low internal volume reduces purge times
- Positive upward and downward stops increase cycle life by preventing over stroking of the diaphragm
- Selection of seat materials for media compatibility and temperature applications
- Unique carrier design disperses gas uniformly through the regulator to improve purging
- Oxygen cleaned in accordance with ASTM G93 Level C

## Specifications:

Functional Performance	
<b>Design</b>	
Burst Pressure	750 psig (52 barg)
Proof Pressure	375 psig (26 barg)
<b>Flow Capacity</b>	
C <sub>v</sub> Options	C <sub>v</sub> 0.06 (std.), C <sub>v</sub> 0.02, C <sub>v</sub> 0.15
<b>Leak Rate: Internal</b>	Bubble Tight
<b>Leak Rate: External</b>	Bubble Tight
<b>Internal Volume</b>	4.0 cc without fittings
<b>Approximate Weight</b>	1.5 lbs. (0.7 kg)

Operating Conditions	
Maximum Inlet	250 psig (17 barg)
Outlet Options	100 torr to 10 psig (-26 in Hg to .7 barg)
Temperature	Metal Knob required for temperature above 150 °F
PCTFE	-40°F to 150°F (-40°C to 66°C)
PEEK™	-40°F to 275°F (-40°C to 135°C)
Vespe®	-40°F to 500°F (-40°C to 260°C)

Material of Construction	
Wetted	
Body	316L Stainless Steel (std.)
Compression Member	Inconel® 625
Diaphragm	Hastelloy® C-22
Diaphragm Pin	Hastelloy® C-22
Poppet	Hastelloy® C-276
Poppet Spring	Inconel® X750
Seat Options	PCTFE (std.), PEEK™ or Vespe®
Washer Backup Options	316 Stainless Steel (std.)
O-Ring Backup Options	FKM (std.) or PTFE
Inlet Screen / Filter	316 Stainless Steel (std.) (60µm mesh screen, 10µm Filter)
Non-Wetted	
Cap	Nickel Plated Brass (std.) or Stainless Steel
Nut	316L Stainless Steel
Knob Options	ABS (std - ambient temperature) or Aluminum

Hastelloy® C-22 and Hastelloy® C-276 are registered trademarks of Haynes International, Inc. Vespe® is a registered trademark of DuPont Performance Elastomers L.L.C. Inconel® and Monel® are registered trademarks of Special Metals Corporation. PEEK™ is a trademark of Victrex plc.

Specialty  
Regulators

# NPR4100 Series

## Flow Curve:

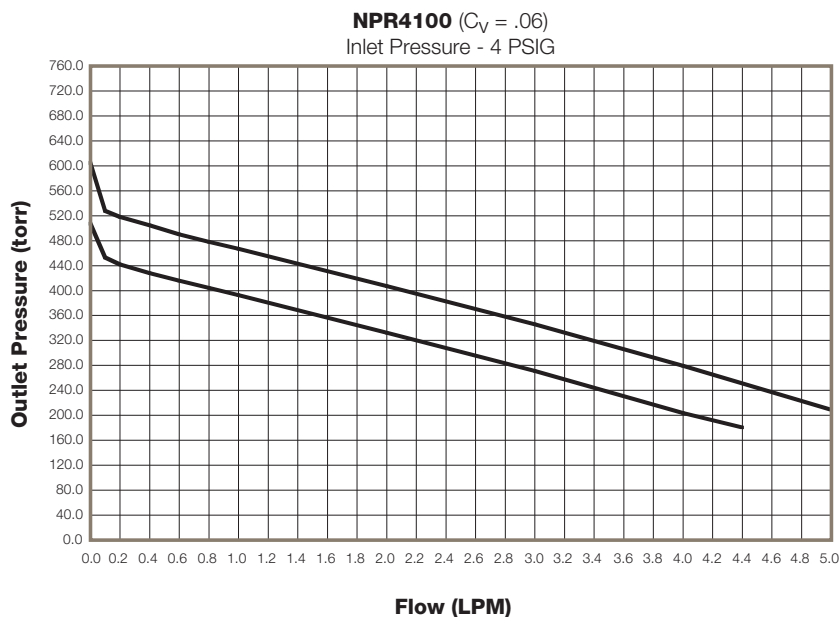

## Dimensional Drawing:

Specialty Regulators

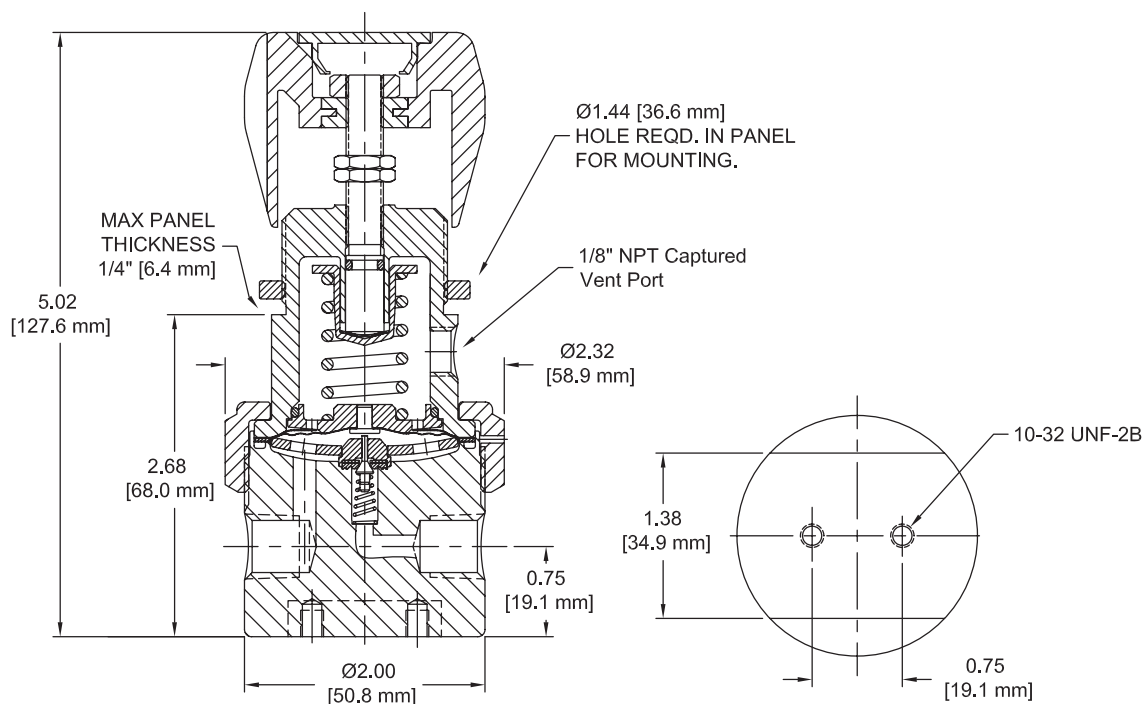

# NPR4100 Series

## Ordering Information:

Building a Part Number: *Example: NPR4100SK4PV3V14BC*

Example Part Number:	NPR410	0	S		K	4P	V3	V1	4	B	C
Ordering Parameters/Options:	Series	Pressure Range	Body Material	Flow Capacity	Seat Material	Porting	Outlet Gauge	Inlet Gauge	Port Style	Port Mounting	Optional Features
Table Reference: (see below)	A	B	C	D	E	F	G	H	I	J	K

A - Series	
NPR410	NPR410 Series Regulator

B - Pressure Range	
0	-26 in. Hg, 0-10 psig

C - Body Material	
S	316L Stainless Steel

D - Flow Capacity	
omit	0.06 C <sub>v</sub> (std.)
1	0.02 C <sub>v</sub>
2	0.15 C <sub>v</sub>

E - Seat Material	
K	PCTFE
P	PEEK™
V	VespeI® (Recommended for Nitrous Oxide (N <sub>2</sub> O) service)

F - Porting	
2P	2 Ports (No X required for gauges, inlet & outlet ports only)
3P	3 Ports (One X for gauge port)
4P	4 Ports (Two X's for gauge ports)
4PB	4 Ports (One X for gauge ports)

G - Outlet Gauge	
V3	-30 in. Hg, 0-30 psig
X	No Gauge (Gauges may be provided by local Parker Distributor)

H - Inlet Gauge (Gauges may be provided by local Parker Distributor)	
V3	-30 in. Hg, 0-30 psig
V1	-30 in. Hg, 0-100 psig
2	0-200 psig
4	0-400 psig
X	No Gauge

I - Port Style	
4	1/4" NPT Female (All Gauges are 1/4" NPT Female)

J - Port Mounting	
B	0.75 port height with 0.75 mounting hole pattern

K - Optional Features (This section may have multiple options)	
C	Corrosion Resistant External (Stainless Steel Cap)
G	Tamper Proof (Not available with M option)
L	PTFE Backup O-ring (PCTFE and PEEK™ Seats Only)
M	Metal Knob

**Note:**  
**Panel Mount Option:** Order Panel Mount Nut Ring (PN: IR4-Panel-Nut-B-NP) as separate line item  
**Vent Muffler Option:** Vent Muffler (PN: Muffler-2F-Bronze) as separate line item.

Parker Instrumentation Products Division reserves the right to plug NPT ports

Specialty Regulators

# SC423XL Series Gas Flow Controller

Low Flow, Vacuum Applications, Stainless Steel

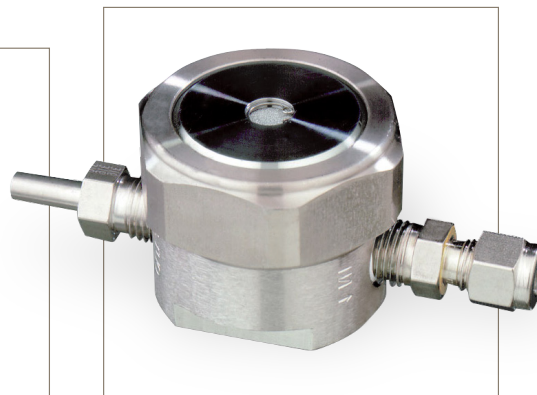

## Value Proposition:

The SC423XL Series Flow Controller is a unique device which supplies a constant flow with a self correcting action to compensate for changes in downstream pressure. The SC423XL was designed for air and analyzer sampling systems which require very low flow rates (less than 10 scc/m). Connected to a vacuum cylinder, the SC423XL provides consistent flow control despite changes in the vacuum.

## Product Features:

- Rugged Design
- Flow Control as low as 1 scc/m
- Adjustable Flows
- Hastelloy® C-22 Diaphragms
- Stable Flows as Vacuum Pressure Changes for 28 in. Hg to 5 in. Hg
- Stable Flows over Wide Temperature Band
- Color Coded Orifices
- Special CFC Free Cleaning
- Tamper Proof
- Oxygen cleaned in accordance with ASTM G93 Level C

## Specifications:

Material of Construction	
Wetted	
Body	316L Stainless Steel
Piston	316L Stainless Steel
Diaphragm	Hastelloy® C-22
Seat	FKM
Seals	FKM
Inlet Fitting	316 Stainless Steel
Outlet Fitting	316 Stainless Steel
Non-Wetted	
Cap	316 Stainless Steel
Nut	316 Stainless Steel
Filter	Sintered Hastelloy®

Functional Performance	
Leak Rate	Inboard Test Method
External	1 x 10 <sup>-6</sup> scc/sec He
Approximate Weight	1.75 lbs. (0.80 kg)

Operating Conditions	
Maximum Inlet	Atmospheric
Outlet	Vacuum
Flow (see Flow Curve)	Low as 1 scc/m
Temperature	-40°F to 200°F (-40°C to 94°C)

Hastelloy® C-22 is a registered trademark of Haynes International, Inc.

For additional information on materials of construction, functional performance and operating conditions, please contact factory.

# SC423XL Series

## Flow Curves:

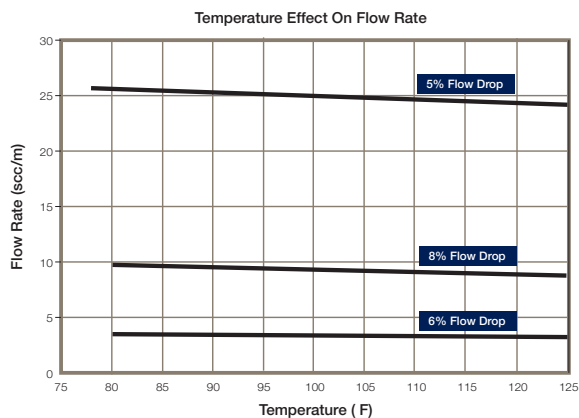
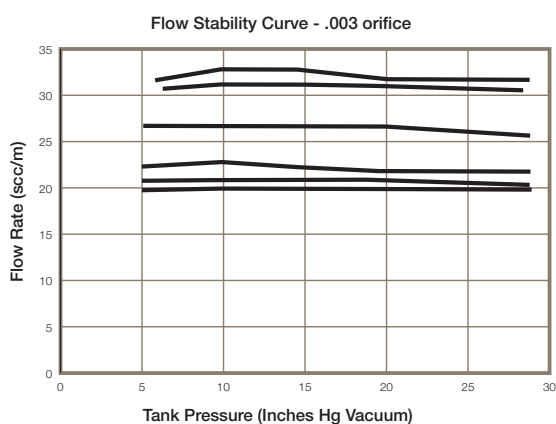
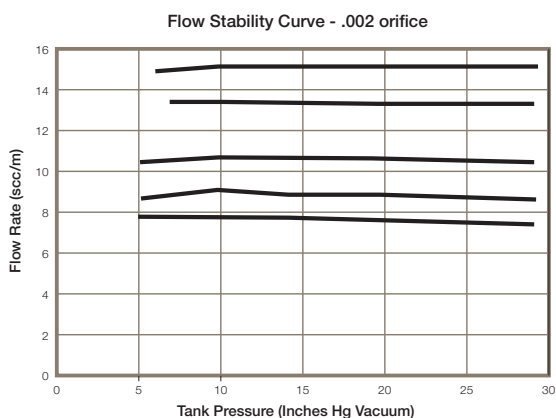
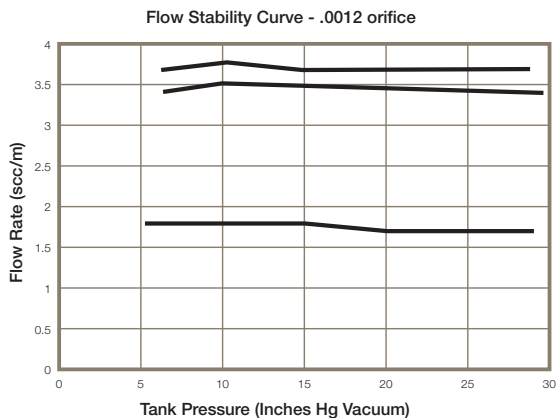
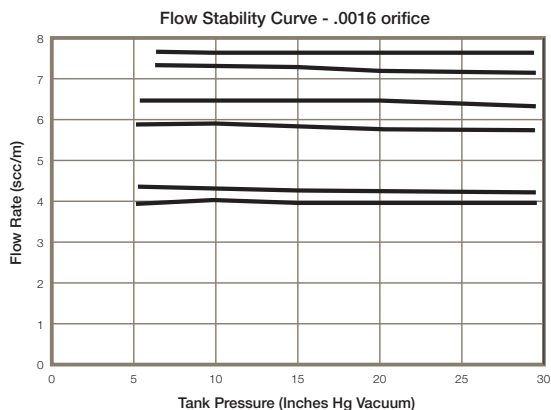

Specialty Regulators

# SC423XL Series

## Dimensional Drawing:

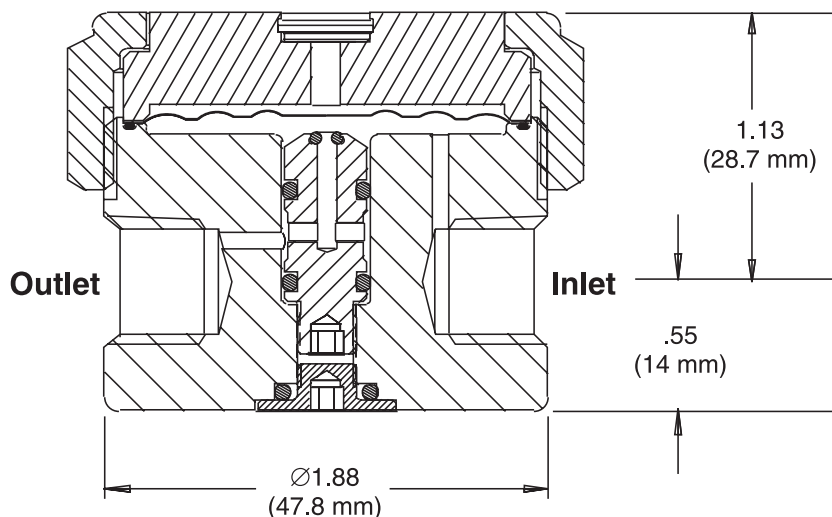

## Ordering Information:

Specialty Regulators

Building a Part Number: *Example: SC423XLS2444*

Example Part Number:	<b>SC423XL</b>	<b>S</b>	<b>24</b>	<b>4</b>	<b>4</b>
Ordering Parameters/Options:	Series	Body Material	Sample Time/Flow Rate	Inlet Connection	Outlet Connection
Table Reference: (see below)	A	B	C	D	E

### A - Series

SC423XL	Gas Flow Controller
---------	---------------------

### B - Body Material

S	316L Stainless Steel
---	----------------------

### C - Sample Time/Flow Rate

3	27.1 - 27.7 sccm (yellow)
8	10.0 - 10.4 sccm (green)
12	6.5 - 6.9 sccm (blue)
24	3.1 - 3.4 sccm (red)

### D - Inlet Connection

4	1/4" NPT Female (All Gauge Ports are 1/4" NPT Female)
---	---

### E - Outlet Connection

X	No Connections
4	1/4" NPT Female (All Gauge Ports are 1/4" NPT Female)

# COSE Series ChangeOver System

Continuous Gas Management



## Value Proposition:

The ChangeOver System (COSE) is a compact turnkey module that assists the operator with their total gas management. The COSE maintains a continuous gas delivery from two separate sources allowing for maximum cylinder gas usage from one source before automatically switching to the second source. The COSE lowers specialty gas costs by maximizing the consumption of gas from each cylinder. In addition, the gas cylinder bank(s) can be monitored remotely utilizing the optional pressure switches reducing the need for visual inspection by the operator.

## Product Features:

- Fully enclosed to protect internal components
- Removable side panels for field maintenance
- Allows change out of depleted cylinder(s) while maintaining gas flow
- Especially suited for continuous on-stream analyzers
- Alarm sensor port for systems integration allowing user to monitor gas consumption
- Regulator design integrates positive upward and downward stops which increases cycle life by preventing over stroking of the diaphragm

## Specifications:

Functional Performance	
<b>Design</b>	
Burst Pressure	9,000 psig (620 barg)
Proof Pressure	4,500 psig (310 barg)
<b>Flow Capacity</b>	C <sub>v</sub> 0.06
<b>Supply Pressure Effect</b>	
With Outlet Regulator	.01 psig/100 psig (.0007/7 barg)
Without Outlet Regulator	0.4 psig/100 psig (.03/7 barg)
<b>Leak Rate: Internal</b>	Bubble Tight
<b>Leak Rate: External</b>	Bubble Tight
<b>Inlet/Outlet Connection</b>	1/4" NPT
<b>Approximate Weight</b>	21 lbs. (9.5 kg)

Operating Conditions	
Maximum Inlet Pressure	3,000 psig (207 barg)
Outlet Pressure	Up to 250 psig (17 barg) maximum
Temperature	-40°F to 150°F (-40°C to 66°C)

Elgiloy® is a registered trademark of Elgiloy Company  
Hastelloy® is a registered trademark of Haynes International, Inc.  
Inconel® is a registered trademark of Special Metals Corporation

Material of Construction	
Wetted	
Body	316L Stainless Steel (std)
Diaphragm	Hastelloy® C-22
Poppet	Hastelloy® C-22
Poppet Spring	Inconel®
Seat Options	PCTFE
Retainer	Inconel®
Carrier	316L Stainless Steel
Washer Backup	316L Stainless Steel
O-ring Backup	Fluorocarbon
Tubing	316 Stainless Steel
Fittings	316 Stainless Steel
Regulator Non-Wetted	
Cap	Nickel Plated Brass
Nut	316 Stainless Steel
Knob	ABS Plastic (Black)
Valve Wetted	
Body	316L Stainless Steel
Diaphragm	Elgiloy® or equivalent
Seat	PCTFE
Valve Non-Wetted	
Bonnet Nut	316 Stainless Steel
Knob	ABS Plastic (Black)

Pressure Control  
Systems

# COSE Series

## Flow Curve:

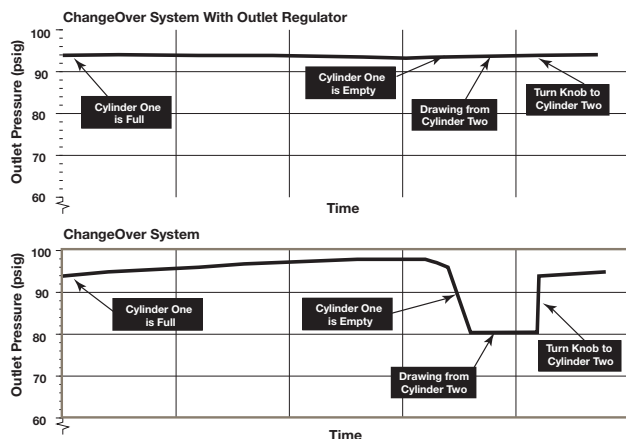

## ChangeOver System Flow Rates:

Based on 400 psig Cylinder Change	
COS Model	Maximum Recommended Flow
COS 200	70 slpm N <sub>2</sub>
COS 250	70 slpm N <sub>2</sub>
COS 150	70 slpm N <sub>2</sub>
COS 100	100 slpm N <sub>2</sub>
COS XXX OR*	70 slpm N <sub>2</sub>

\*ChangeOver System with optional outlet regulators

## Dimensional Drawing:

With Outlet Regulator

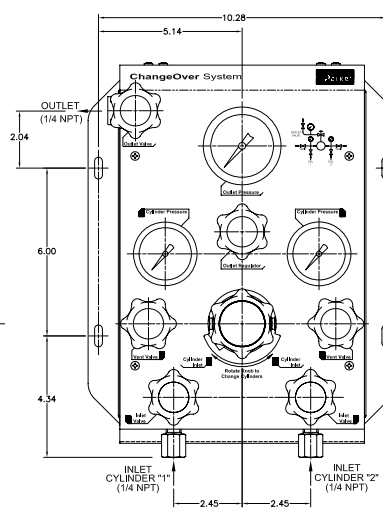
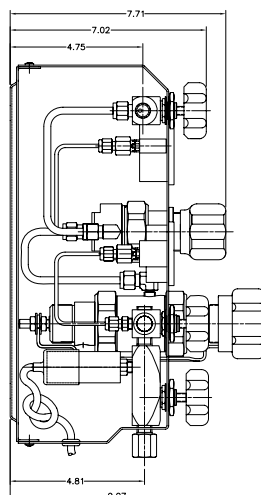

Without Outlet Regulator

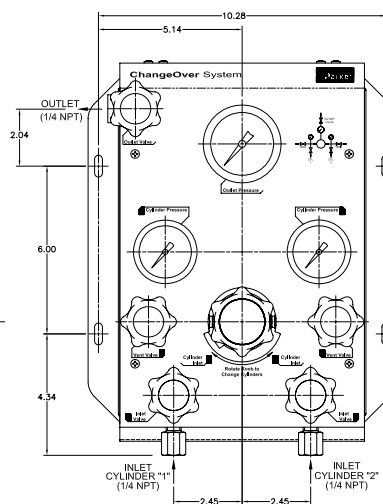
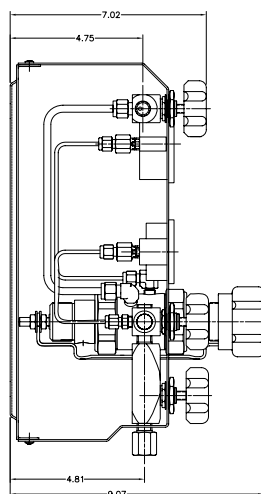

# COSE Series

## Ordering Information:

Building a Part Number: <i>Example: COSE100SOR</i>				
Example Part Number:	COSE	100	S	OR
Ordering Parameters/Options:	Series	Pressure Settings	Material	Options
Table Reference: (see below)	A	B	C	D

A - Series	
COSE	ChangeOver System (COSE)

C - Material	
S	316L Stainless Steel

B - Pressure Setting	
100	100 psig
150	150 psig
200	200 psig
250	250 psig

D - Optional Features (This section can have multiple options)	
A1	Pressure Switches (includes 2 pressure switches)
OR	Outlet Regulator
Omit	No Outlet Regulator

**Notes:**  
Inlet valves and gauges are standard on all units.

## Applications:

### Specialty Gases

All Specialty Gases used for Process and Purging Applications

### Industrial/Analyzer

- Refineries
- Test Cells
- Emission Analysis
- Laboratories
- Laser Gas Systems
- Research and Development
- Gas and Liquid Chromatography
- High Volume Gas Manufacturing Facilities

# COSM Series

## Mini ChangeOver System

Continuous Gas Management



### Value Proposition:

The Mini ChangeOver System (COSM) from Parker is a compact, turnkey module that assists operators with their total gas management. Continuous gas delivery is maintained from two separate sources, allowing for maximum cylinder gas usage from one source before automatically switching to the second source. COSM lowers specialty gas costs by maximizing the consumption of gas from each cylinder.

### Product Features:

- Allows changeout of depleted cylinder(s) while maintaining gas flow
- Especially suited for continuous on-stream analyzers
- Compact design reduces footprint
- Maximum inlet pressure of 3,000 psig with 4 delivery options (100, 150, 200 or 250 psig)
- Outlet Regulator for constant or steady line pressure during changeover
- Regulator design integrates positive upward and downward stops which increases cycle life by preventing over stroking of the diaphragm
- Available in Stainless Steel

### Specifications:

Functional Performance	
<b>Design</b>	
Burst Pressure	9,000 psig (620 barg)
Proof Pressure	4,500 psig (310 barg)
<b>Flow Capacity</b>	C <sub>v</sub> 0.06
<b>Leak Rate:</b> Internal	Bubble Tight
<b>Leak Rate:</b> External	Bubble Tight
<b>Supply Pressure Effect</b>	0.01 psig/100 psig, (0.0007 barg/7 barg)
<b>Approximate Weight</b>	8.4 lbs. (without gauges)

Operating Conditions	
Maximum Inlet	3,000 psig (207 barg)
Outlet	Up to 250 psig
<b>Temperature</b>	-40°F to 150°F (-40°C to 66°C)

Material of Construction	
Regulator Wetted	
Body	316L Stainless Steel (std)
Diaphragm	Hastelloy® C-22
Poppet	Hastelloy® C-276
Poppet Spring	Inconel® X750
Seat	PCTFE
Compression Member	Inconel® 625
Carrier	316L Stainless Steel
Washer Backup	316 Stainless Steel
O-Ring Backup	Fluorocarbon (FKM)
Fittings	316 Stainless Steel
Inlet Screen/Filter	316 Stainless Steel (60µm mesh screen, 10µm Filter)
Regulator Non-Wetted	
Cap	Nickel Plated Brass
Nut	316 Stainless Steel
Knob	ABS Plastic

Hastelloy® is a registered trademark of Haynes International, Inc.  
Inconel® is a registered trademark of Special Metals Corporation

# COSM Series

## Flow Curve:

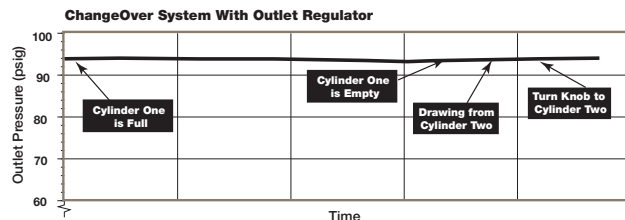

## ChangeOver System Flow Rates:

Based on 400 psig Cylinder Change	
COSM Model	Maximum Recommended Flow
COSM 100	100 slpm N <sub>2</sub>
COSM 150	70 slpm N <sub>2</sub>
COSM 200	70 slpm N <sub>2</sub>
COSM 250	70 slpm N <sub>2</sub>

## Dimensional Drawing:

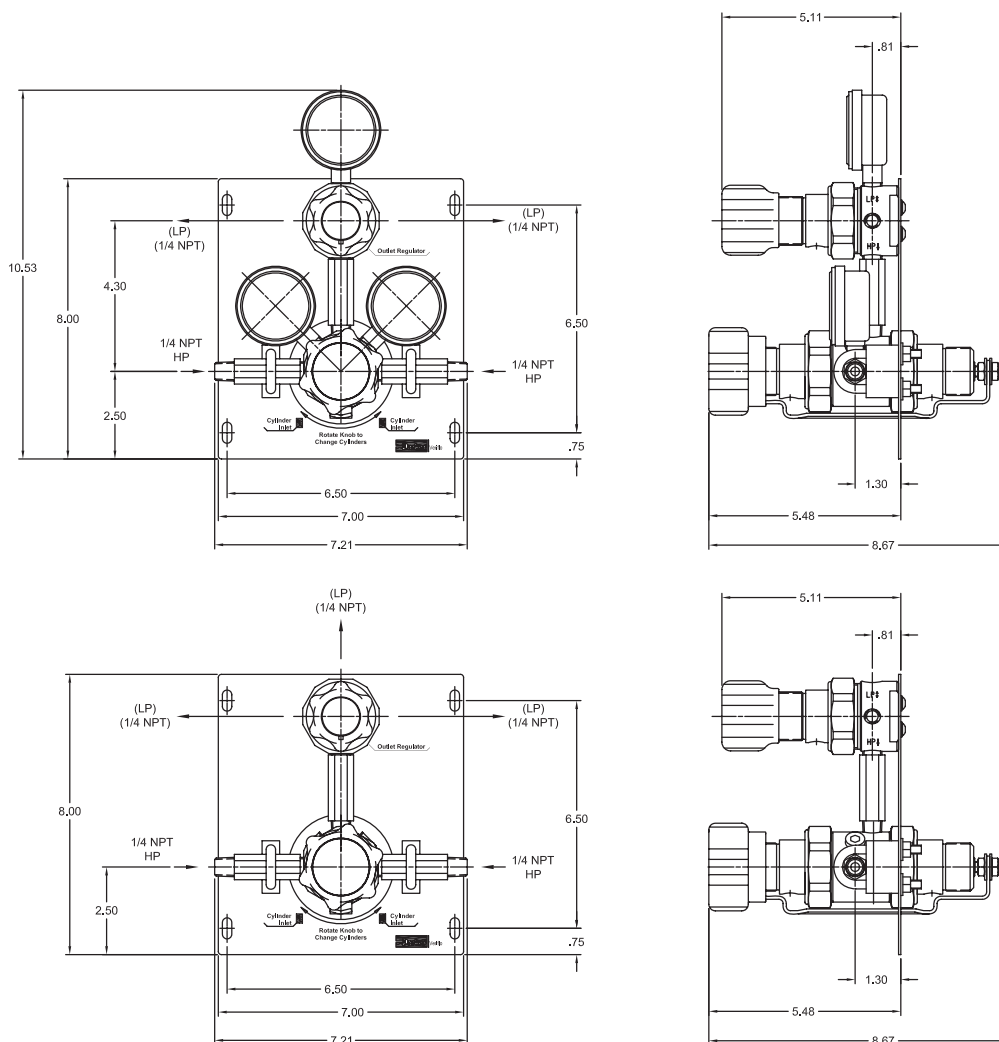

Pressure Control  
Systems

# COSM Series

## Ordering Information:

Building a Part Number: *Example: COSM100SORG*

Example Part Number:	<b>COSM</b>	<b>100</b>	<b>S</b>	<b>OR</b>	<b>G</b>
Ordering Parameters/Options:	Series	Pressure Settings	Material	Optional Regulator	Optional Material
Table Reference: (see below)	<b>A</b>	<b>B</b>	<b>C</b>	<b>D</b>	<b>E</b>

### A - Series

COSM	Mini ChangeOver System (COSM)
------	-------------------------------

### C - Material

S	316 Stainless Steel
---	---------------------

### B - Pressure Setting

100	100 psig
150	150 psig
200	200 psig
250	250 psig

### D - Outlet Regulator

OR	Outlet Regulator (Standard, no other options available)
----	---

### E - Optional Features

G	Gauges (Includes 2 inlet gauges and one outlet gauge)
---	---

# Vent Master™

## Process Analyzer Vent-Header Pressure Control System

Temperature • Flow • Pressure



### Value Proposition:

After a process sample stream is analyzed, it must be disposed of in a manner consistent with environmental regulations. Today, as in the past, it has been common practice to simply vent the sample stream to the atmosphere. As environmental regulations become more stringent, it is becoming undesirable, if not illegal, to admit these samples to the atmosphere.

For an analyzer to operate correctly, it must be calibrated and operated under the same conditions. These critical conditions are temperature, flow and pressure, with the pressure of the measurement cell being the most critical. Venting analyzer effluent to atmosphere is not only convenient, but it also provides a very stable reference pressure for the analyzer measurement cell. In other words, the measurement cell “floats” on atmospheric pressure.

Analyzer outlet sample streams are traditionally collected into a closed vent header. This vent header either flows to atmosphere or back to the process. When atmospheric venting is not allowed, the most common disposal point is the plant flare where the analyte sample stream is burned. However, the flare header is subject to pressure variations as high as 20 psig or more as process upsets create backpressure. When venting an analyzer into the flare collection system, the measurement cell “floats” on these varying pressures. If this condition is left unchecked these pressure fluctuations will result in significant analyzer measurement errors.

The primary function of the Parker Vent Master™ is to isolate the analyzer from fluctuating outlet pressures by controlling the pressure of the collection header (commonly referred to as the Vent Header) and pumping the effluent sample gases into the fluctuating return system.



Image courtesy of ABB



Pressure Control Systems

# Vent Master™

## Functional Options:

The Parker Vent Master™ can be configured to perform in several different applications as outlined in the following nomenclature summary.

- The Eductor model (EDR) is the most common and is used when disposing analyzer effluent gasses to a flare system. The -EDR model requires a bulk nitrogen source to provide the necessary motive force for the eductor.
- The Eductor Natural Gas model (EDRNB) is very similar to the -EDR but it incorporates non-bleed pneumatic circuitry that enables the use of fuel gas as the motive force for the eductor.
- The pump (PMP) model is most commonly used when returning analyzer effluent to the process, or any other point with a return pressure above 20 psig. In this case a positive displacement pump (provided by others) is utilized.
- The model with no pump or eductor (NPE) is used when an external plant vacuum system is available.

All configurations of the Parker Vent Master™ provide exceptional pressure stability in the analyzer effluent vent header regardless of upstream flow and downstream pressure fluctuations as detailed below:

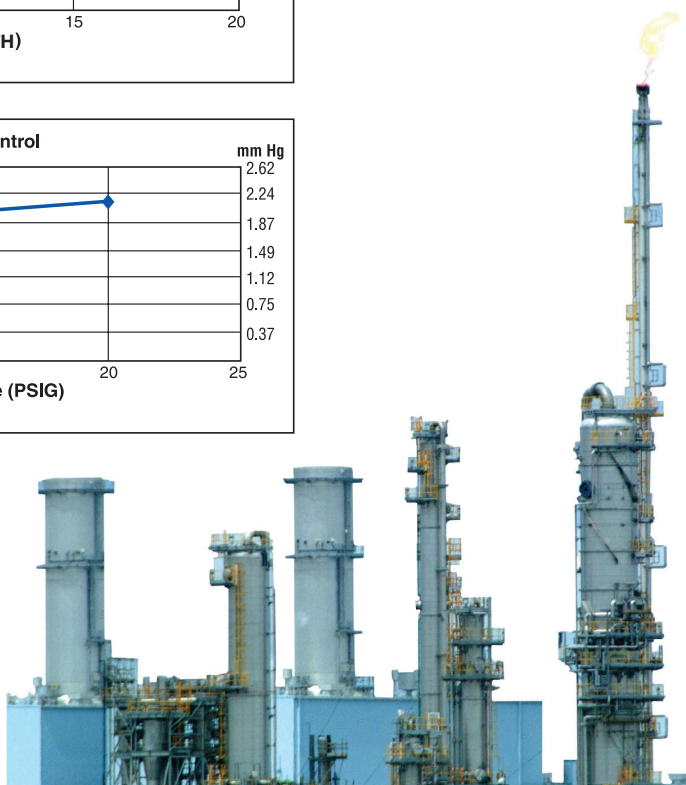
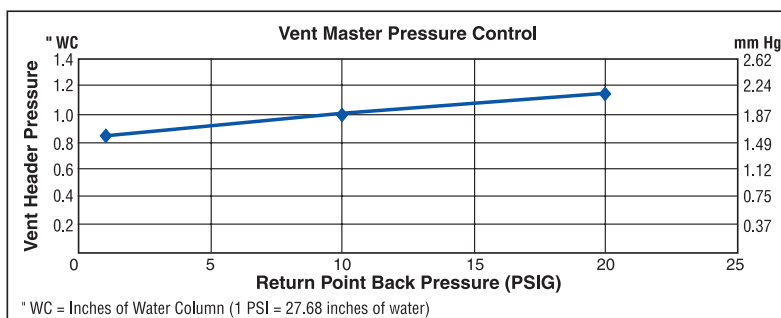
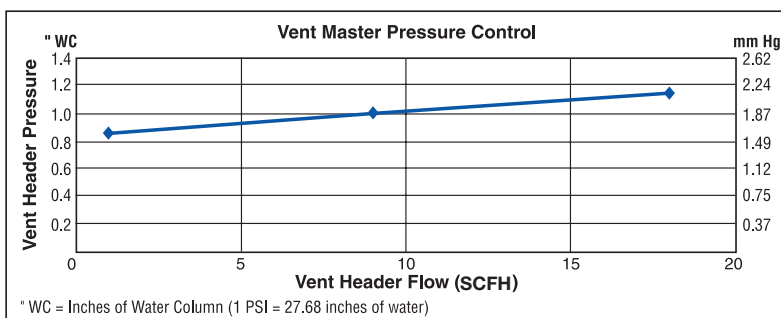

# Vent Master™

## Parker Vent Master™ Eductor (-EDR) Model Theory of Operation:

This system is comprised of regulators, gauges, a rotameter, a controller and an eductor mounted in a small enclosure for ease of operation and installation. A low-pressure regulator (PR-1) with a large sensitive diaphragm is also included with the system but is mounted directly onto the vent header as shown on the schematic below and layout drawing on page 7. The eductor flow capacity dictates the Vent Master's maximum analyzer effluent flow capacity. Parker Vent Master™ EDR models have a wide range of analyte flow, return point back pressure and motive force capabilities.

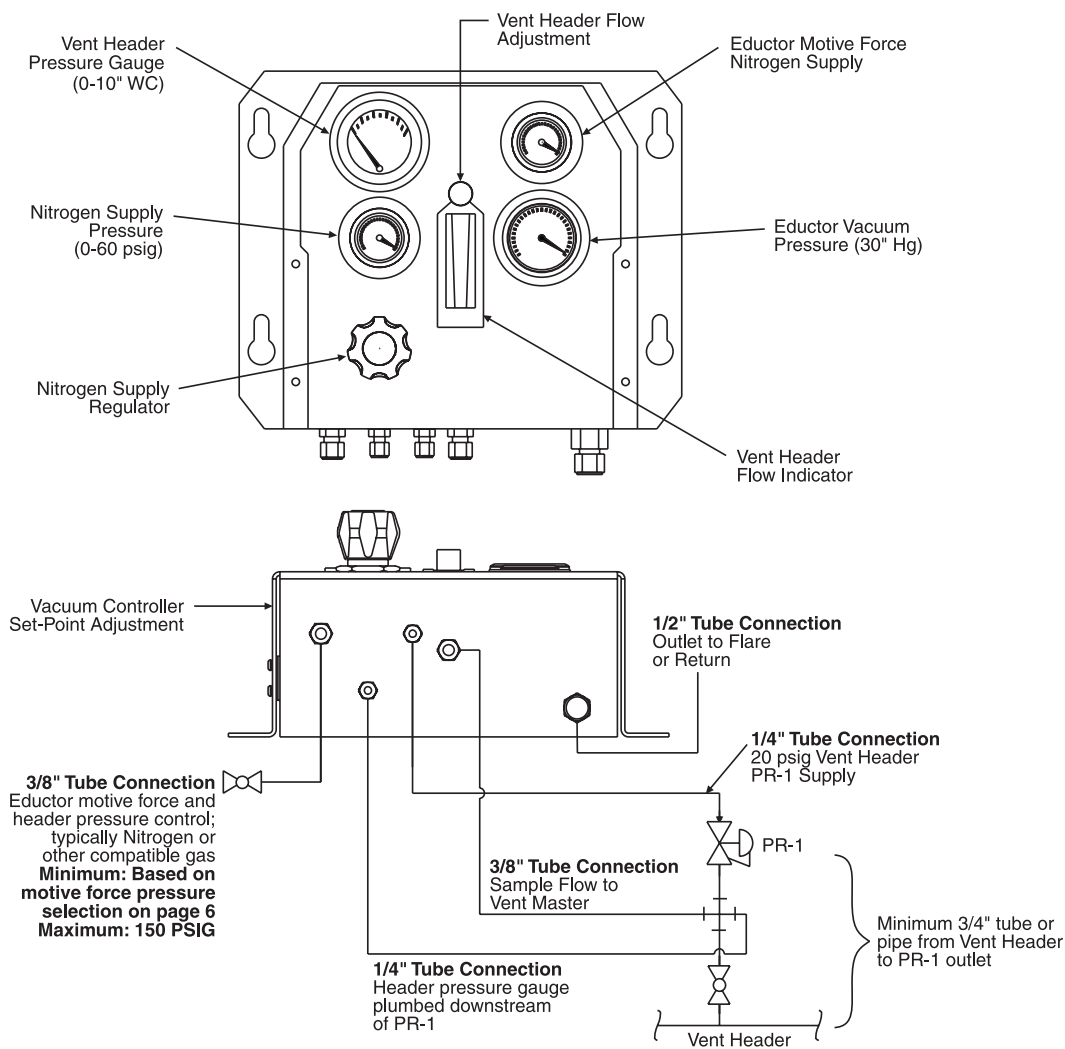

Pressure Control Systems

# Vent Master™

## Parker Vent Master™ Eductor Model Theory of Operation (Continued):

PR-1 is the vent header pressure controller. Its function is to constantly flow a Nitrogen makeup gas into the vent header, sufficient to maintain a constant pressure. While each analyzer will vent effluent gas into the vent header by varying amounts, PR-1 will sense the header pressure and provide Nitrogen to makeup the difference necessary to maintain a stable +1" WC pressure. Simultaneously, the Parker Vent Master™ eductor will pump a constant analyzer effluent and Nitrogen makeup mixture from the Vent Header.

For example, if the Vent Header Flow Adjustment (FI-1) is set at 14 SLPM and the analyzers are venting a total of 12 SLPM into the vent header, PR-1 will supply 2 SLPM of Nitrogen. The flow capacity limiting component in the Parker Vent Master™ is the eductor. The Parker Vent Master™ is available with three different eductor capacities as outlined on the performance curves on page 6. In all cases, test results show that the Vent Header pressure will be maintained to within .3" WC pressure variation over the flow capacity range of each eductor. The Parker Vent Master™ incorporates a Nitrogen Economizer Circuit which throttles the eductor's motive force flow necessary to maintain a constant 6" Hg vacuum. This circuit conserves Nitrogen use and reduces the normal motive pressure eductor supply to approximately 20 psig, with an eductor return point back pressure of 1 psig. As the eductor's back pressure increases (caused by increasing flare header pressures) the vacuum created by the eductor will be reduced.

The Economizer Circuit vacuum controller monitors the eductor's vacuum and automatically adjusts the motive force flow to the eductor accordingly to maintain a constant differential pressure necessary to facilitate a constant flow rate from the Vent Header. The motive force Nitrogen flow rate can vary from 3 to 9 SCFM depending upon the return point back pressure of the eductor as outlined in the Nitrogen Motive Force Consumption chart below.

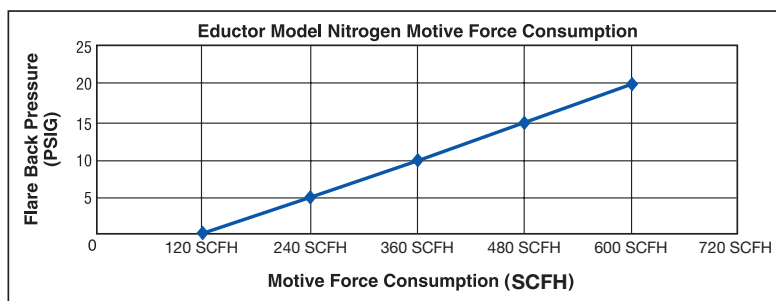

**Note:** The standard PR-1 incorporates an internal relief valve on its diaphragm. The relief valve will only open when the Vent Header pressure exceeds 7" WC. The threaded vent port on the dome of the PR-1 regulator must be vented to a safe area and MUST be maintained at atmospheric pressure. ANY pressure change in the regulators dome connection will be reflected in the Vent Header. Consult factory for a PR-1 without a relief valve.

Nitrogen is the normal makeup and motive force gas used to drive the eductor because it is inert. In cases where Nitrogen is not desirable, Natural Gas can also be used to drive the eductor into a flare system or any other gas that is compatible with the process. In this case, the -EDRNB should be specified.

# Vent Master™

## Parker Vent Master™ Eductor Motive Force / Return Point Back Pressure / Flow Curves:

The -EDR version of the Vent Master is available with three different eductor capacities. Proper eductor sizing is based on three critical system variables:

- Motive force pressure availability
- Maximum analyte flow from the Vent Header
- Maximum return point back pressure

Use the graphs at the right to determine the proper eductor size for an application. When the flow and return point back pressure are plotted as shown in the lines labeled “Example 1” the entire area below the plotted line must fall within the area of the line representing the available motive force pressure.

**Example 1:** An analyzer shelter has 8 different continuous analyzers each flowing 1 SLPM; allowing for a Nitrogen makeup cushion of 2 SLPM, the total flow is 10 SLPM. The return point is the flare header that typically runs at a pressure of 1-2 psig, but process upsets can spike this pressure as high as 22 psig. A bulk Nitrogen source with 90 psig is available for the motive force.

The red line in the graphs at right reflect the maximum flow and return point back pressure described above. In this application, the “A” eductor should be selected because it is the only graph which shows the entire dashed red line within (to the left of) the 90 psig eductor motive force value. Both the “B” and “C” eductors cannot pump against a back pressure of 22 psig at a 10 SLPM flow rate on the 90 psig motive force curve.

**Example 2:** A shelter’s Vent Header has a total analyte volume of 33 SLPM and the return is going back to the process that runs from 35-45 psig. In this case, none of the eductors have the capacity for the application and, the Parker Vent Master™ would be configured for a mechanical pump.

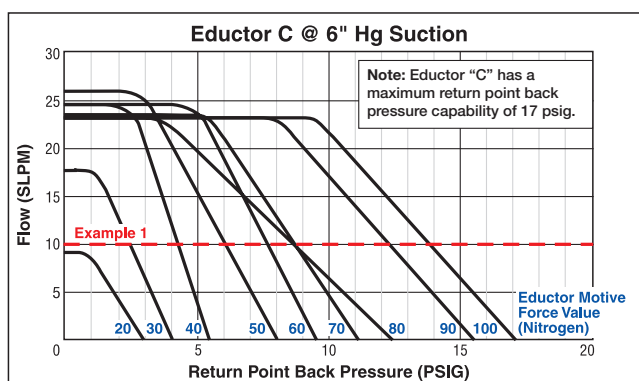
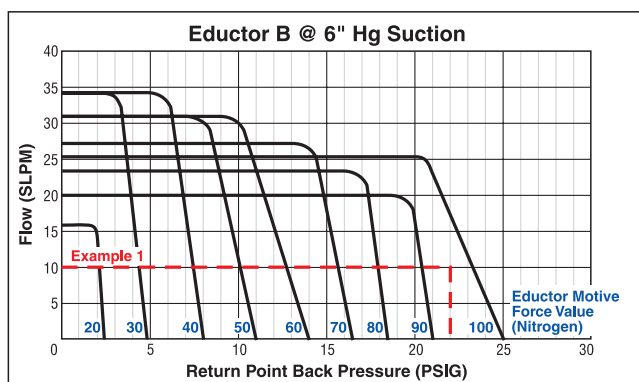
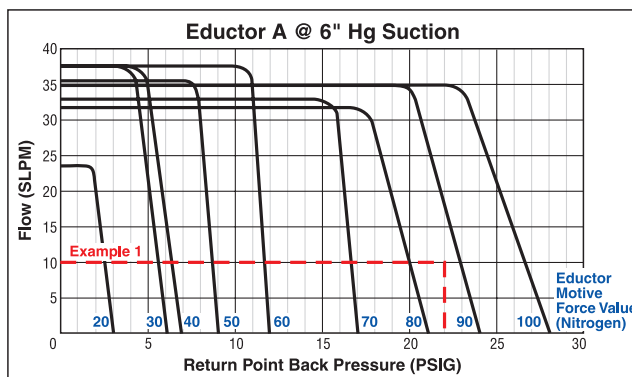

# Vent Master™

## Parker Vent Master™ Nitrogen (-EDR) Model Installation and Startup Procedures:

1. Ensure that all connections are made as per the drawing below. It is very important to maintain a minimum pressure drop from the Vent Header to the outlet of PR-1. A straight run of 3/4" tube or pipe is recommended.
2. Close V-1.
3. Ensure that the eductor outlet to the flare is not blocked. Blocking this flow will cause PR-1 to relieve to its vent and could cause damage to the system.
4. Open V-2 to initiate Nitrogen flow.
5. Adjust PR-2 to read 20 psig on PI-1.
6. PI-4 should read 6" Hg vacuum. If adjustment is required, remove the small cover on the upper left side of the case (X marks the spot below) with a 1/8" Allen Wrench, then adjust the set point until the vacuum is reading 6" Hg vacuum. Reinstall the cover. Adjustment should be made carefully. Full rotation of adjusting screw is not required. Vacuum is set at the factory so any adjustments should be minimal.
7. Adjust the FI-1 rotameter needle valve to at least 2 SLPM higher than the MAXIMUM flow from the analyzers, keeping in mind abnormal flow rates such as calibration gas introduction. Example: If your analyzers contribute 10 SLPM of flow to the vent header, adjust the rotameter to 12 SLPM or higher.
8. At this time PI-2 should read around 1" WC. The set point of PR-1 is fixed and cannot be field adjusted.
9. Open V-1.
10. The Parker Vent Master™ is now in service and will maintain the header at approximately 1" WC  $\pm$ .15". As the flare header pressure increases PI-3 (motive force pressure) will increase. PI-3 will fluctuate up and down with the flare header pressure.

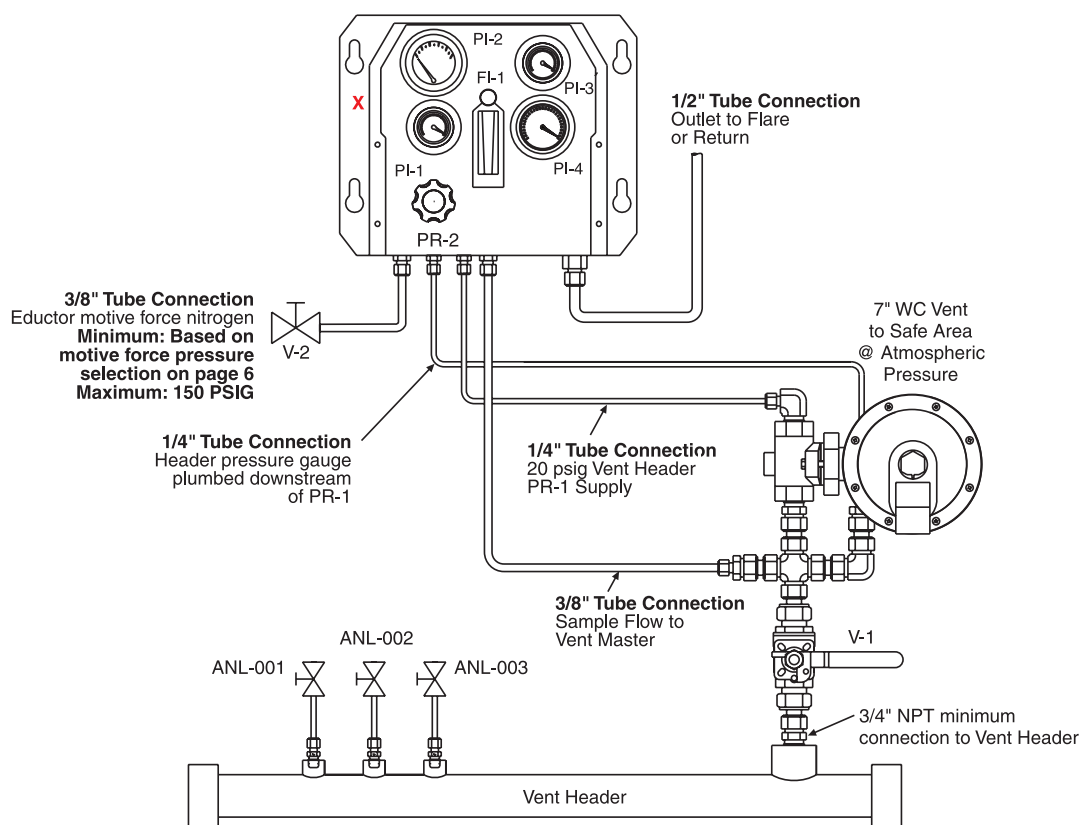

Pressure Control Systems

# Vent Master™

## Parker Vent Master™ Natural Gas (-EDRNB) Model Installation and Startup Procedures:

1. Ensure that all connections are made as per the drawing below. It is very important to maintain a minimum pressure drop from the Vent Header to the outlet of PR-1. A straight run of 3/4" tube or pipe is recommended.
2. Close V-1.
3. Ensure that the eductor outlet to the flare is not blocked. Blocking this flow will cause PR-1 to relieve to its vent and could cause damage to the system.
4. Turn on the 40 psig air supply, then open V-2 to initiate Fuel Gas flow.
5. PI-4 should read 6" Hg vacuum. If adjustment is necessary, remove the small cover on the upper left side of the case (X marks the spot below) with a 1/8" Allen Wrench, then adjust the set point until the vacuum is reading 6" Hg. Reinstall the cover. Adjustment should be made carefully. Full rotation of adjusting screw is not required. Vacuum is set at the factory so any adjustments should be minimal.
6. Adjust the FI-1 rotameter needle valve to at least 2 SLPM higher than the MAXIMUM flow from the analyzers, keeping in mind abnormal flow rates such as calibration gas introduction. Example: If your analyzers contribute 10 SLPM of flow to the vent header, adjust the FI-1 rotameter to 12 SLPM or higher.
7. At this time PI-2 should read around 1" WC. The set point of PR-1 is fixed and cannot be field adjusted.
8. Open V-1.
9. The Parker Vent Master™ is now in service and will maintain the header at approximately 1" WC  $\pm$  .15". As the flare header pressure increases, PI-3 (motive force pressure) will increase. PI-3 will fluctuate up and down with the flare header pressure.

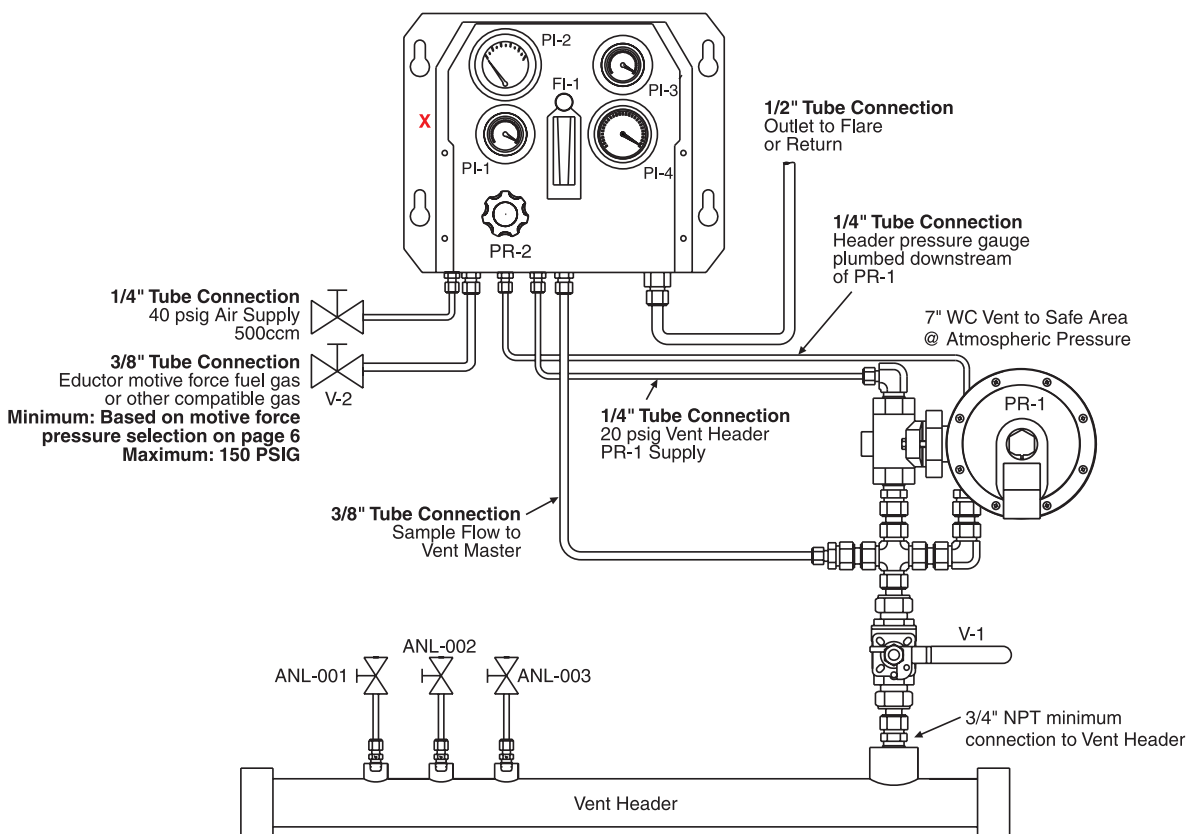

Pressure Control  
Systems

# Vent Master™

## Parker Vent Master™ Pump (-PMP) Model Theory of Operation:

In applications where the flow rate or back pressure conditions exceed the capabilities of the available eductors, or if introducing a motive gas is not practical, an alternate pumping method must be employed. This method usually employs a centrifugal or positive displacement pump (provided by others). The use of a mechanical pump has the advantage of being able to pump into much higher backpressures and not introduce motive gases into the system. The big disadvantage of course, is that they are mechanical and require considerable maintenance for reliable operation.

When a mechanical pump is used instead of an eductor, the economizer circuit is not required. Instead a vacuum regulator is used to control the suction pressure of the pump by introducing a gas, usually Nitrogen (or other gas compatible with the return point), sufficient to control the suction pressure at 6" Hg vacuum. This will control the differential pressure across the rotameter's throttling valve, which will provide a constant flow from the Vent Header. This method will provide extremely stable flow and pressure control of the Vent Header, at flow rates up to 200 SLPM.

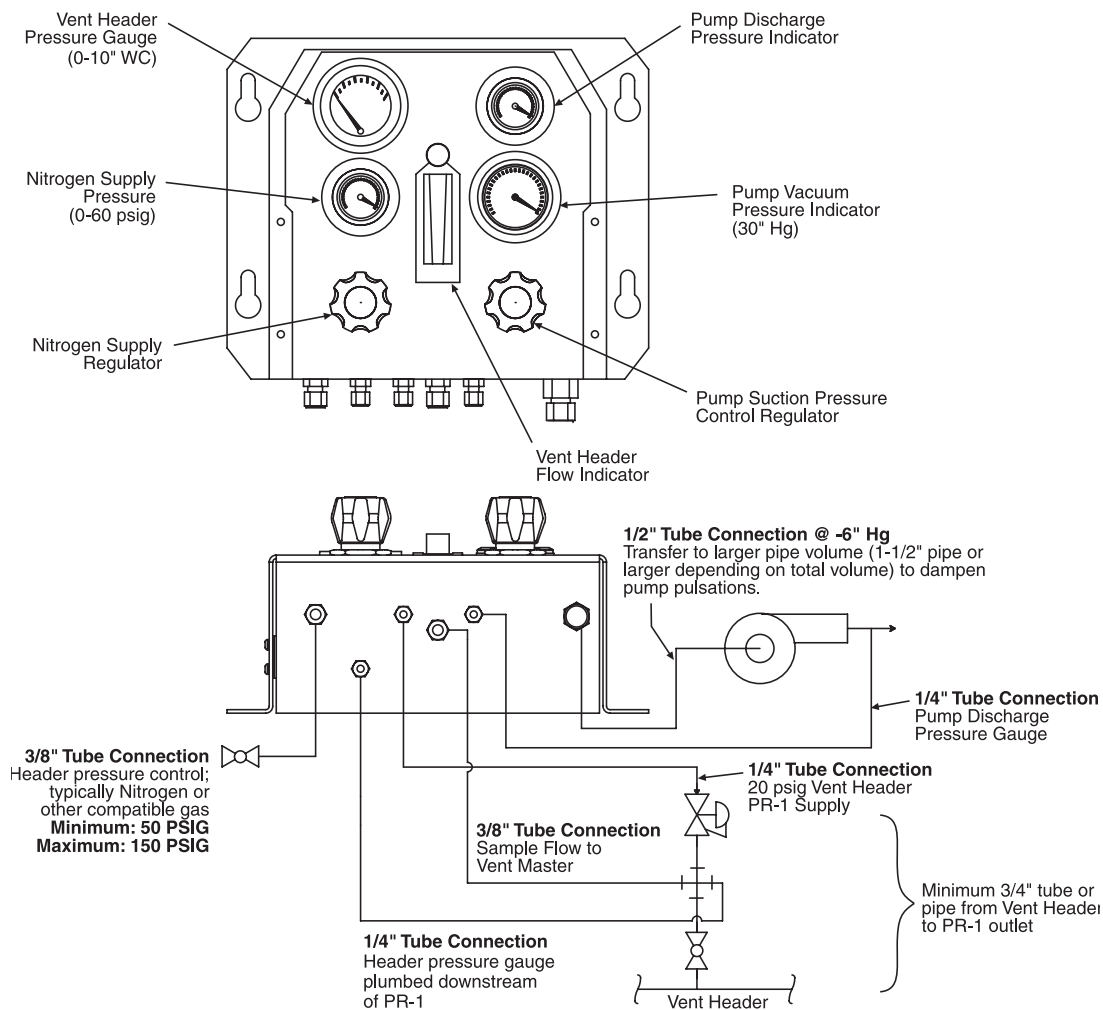

Pressure Control Systems

# Vent Master™

## Parker Vent Master™ Pump (-PMP) Model Installation and Startup Procedures:

**Specifying a Pump:** Vent Master™ -PMP applications require a mechanical pump provided by others. In order to properly specify a positive displacement pump, the manufacturer will need to know the following:

- (1) the inlet (suction) pressure which is a constant -6" Hg
- (2) the maximum analyte volume to be pumped
- (3) the maximum back pressure at the return point
- (4) hazardous area classification, voltage and other electrical requirements

Air Dimensions, Incorporated ([www.airdimensions.com](http://www.airdimensions.com)) can assist with diaphragm pump specifications.

1. Ensure that all connections are made as per the drawing below. It is very important to maintain a minimum pressure drop from the Vent Header to the outlet of PR-1. A straight run of 3/4" tube or pipe is recommended.
2. Close V-1.
3. Open V-2 to initiate Nitrogen flow.
4. Adjust PR-2 to read 20 psig on PI-1.
5. Turn on the pump.
6. Adjust PR-3 to read 6" Hg vacuum on PI-4.
7. Adjust the FI-1 rotameter needle valve to at least 2 SLPM higher than to MAXIMUM flow from the analyzers, keeping in mind abnormal flow rates such as calibration gas introduction. Example: If your analyzers will contribute 10 SLPM of flow to the vent header, adjust the rotameter to 12 SLPM or higher.
8. At this time the PI-2 should read around 1" water. This is the fixed set point of PR-1.
9. Open V-1.
10. The Parker Vent Master™ is now in service. It will maintain the header at approximately 1" WC  $\pm$ .15".

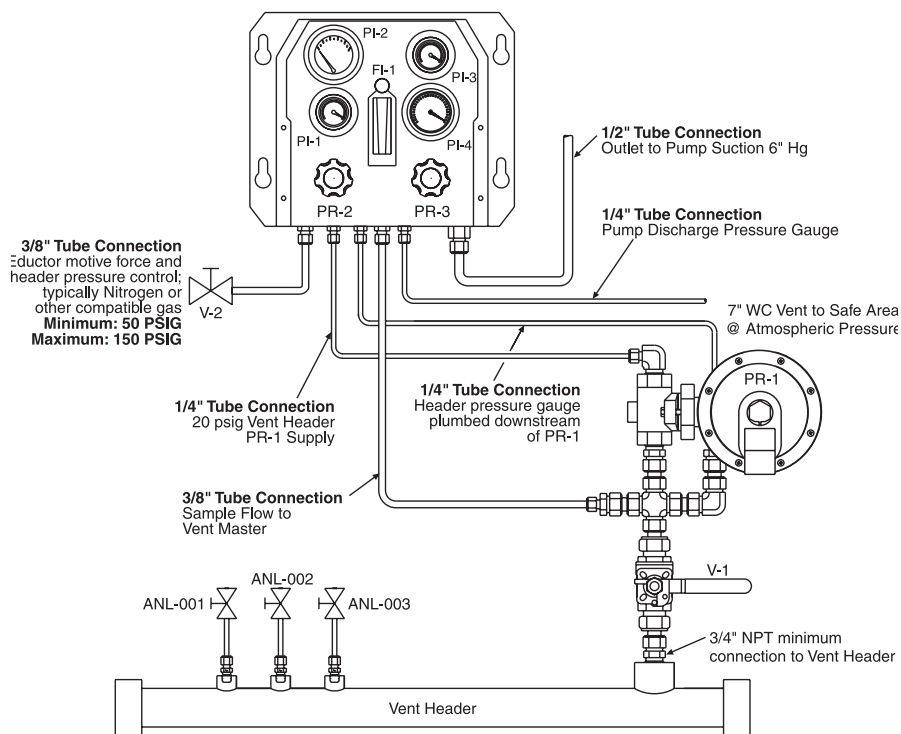

# Vent Master™

## Parker Vent Master™ No Pump or Eductor (-NPE) Model Theory of Operation:

The Parker Vent Master™ requires a lower pressure on the outlet of the rotameters throttling valve of at least -2.5 psig in order to have enough differential pressure to produce 18 SLPM of flow. This lower outlet pressure is provided by either using the standard economizer circuit with the eductor, the mechanical pump, or by an available lower pressure in the process. Using this available lower pressure is considered the best way because it requires no pumps or motive gases. The Parker Vent Master™ system uses a vacuum isolation valve in this circuit (V-1).

This isolation valve acts as a load valve, limiting the amount of vacuum exposed to the outlet of the rotameter's throttling valve. A vacuum regulator is also employed in this circuit. The load valve limits the amount of gas needed, from the vacuum regulator, to control the vacuum on the rotameters outlet valve. The vacuum regulator capacity is limited and would not be able to counter the external vacuum source therefore the load limiting valve is used to limit the total flow into the external vacuum. With the external vacuum limited, with this valve (V-1), the vacuum regulator can now control the vacuum on the rotameters outlet-throttling valve.

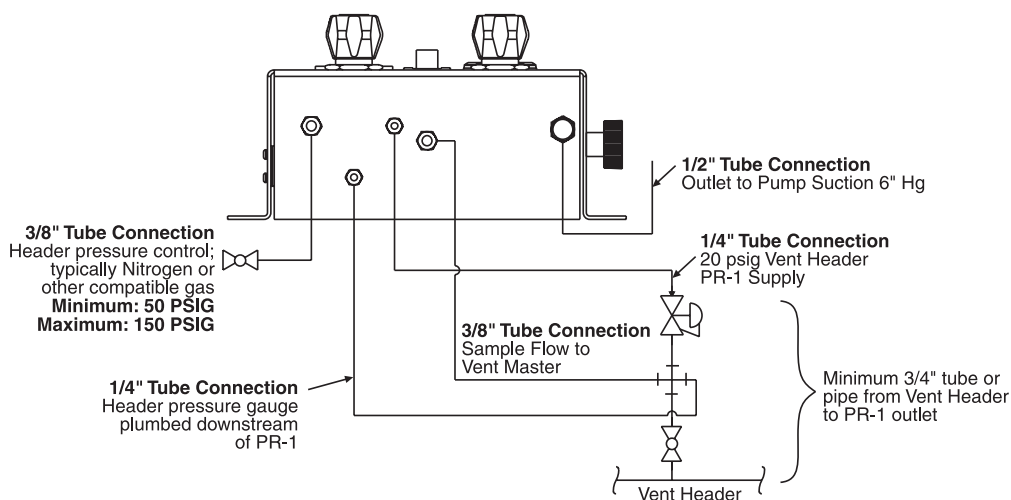
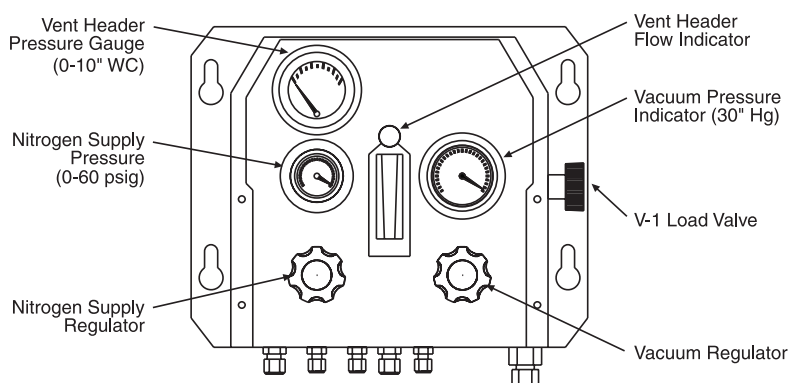

Pressure Control Systems

# Vent Master™

## Parker Vent Master™ No Pump or Eductor (-NPE) Model Installation and Startup Procedures:

1. Ensure that all connections are made as per the drawing below. It is very important to maintain a minimum pressure drop from the Vent Header to the outlet of PR-1. A straight run of 3/4" tube or pipe is recommended.
2. Close V-1.
3. Fully open FI-1 (turn counter clockwise).
4. Close V-3 completely, clockwise, and then crack it open two turns.
5. Open V-2 to initiate Nitrogen flow.
6. Adjust PR-2 to read 20 psig on PI-1.
7. Adjust PR-3 to read 6" Hg vacuum on PI-4.
8. Adjust V-3, open or close, until rotameter flow is greater than analyzer flow into the header, keeping in mind abnormal flow rates such as calibration gas. Example: If your analyzers will contribute 10 SLPM of flow to the vent header, adjust the rotameter to 12 SLPM or higher.
9. At this time PI-2 should read around 1" water. This is the fixed set point of PR-1.
10. Open V-1.
11. The Parker Vent Master™ is now in service and will maintain the header at approximately 1" WC  $\pm$ .15".

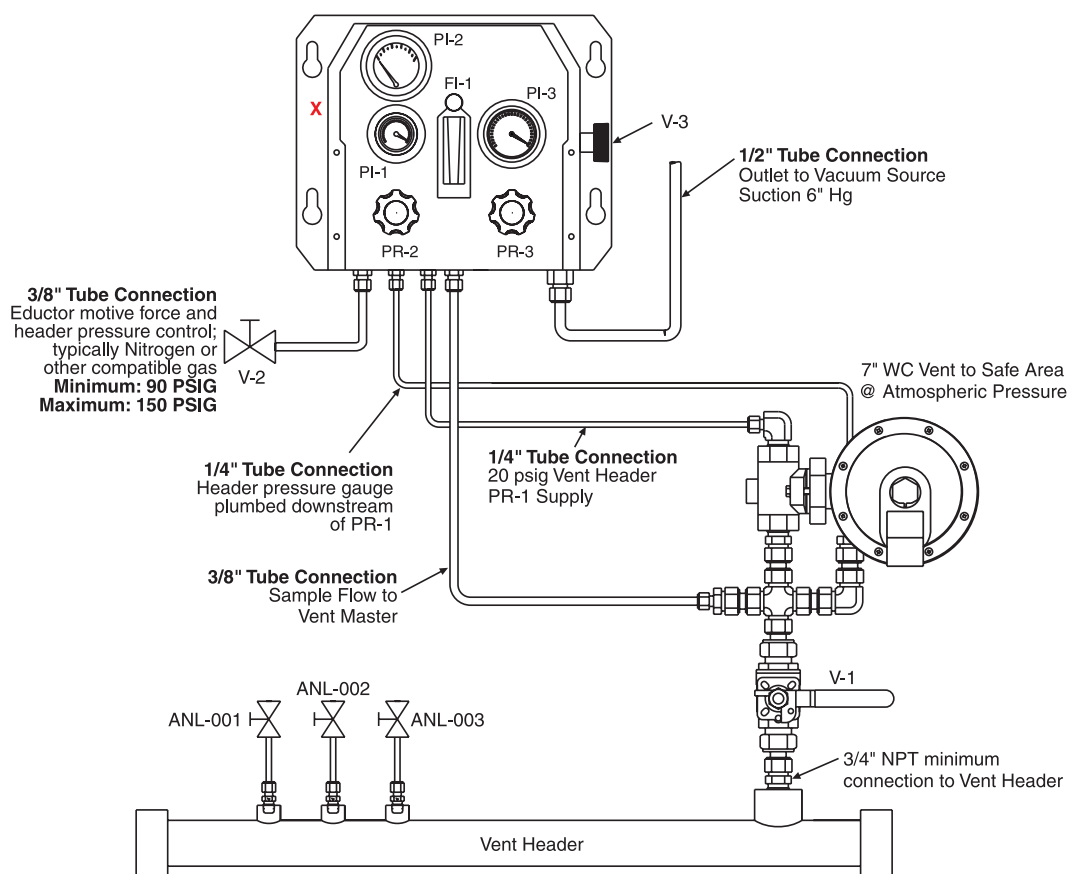

Pressure Control Systems

# Vent Master™

## Dimensions:

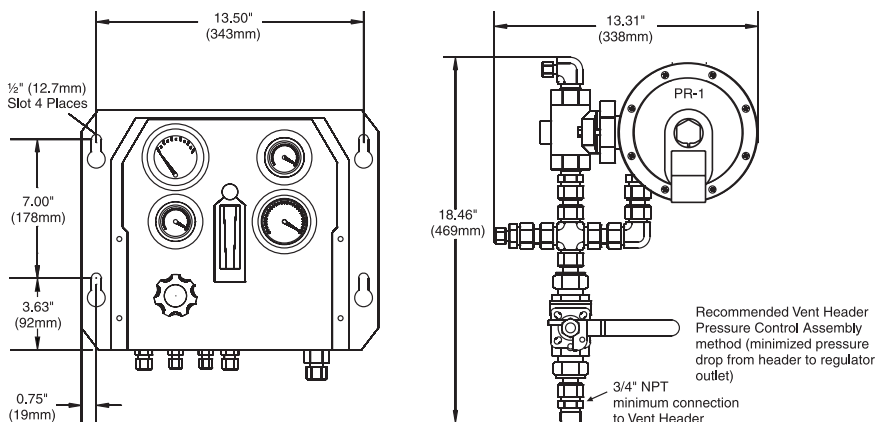

## How to Order:

The correct part number is easily derived from the following example and ordering chart. The seven product characteristics required are coded as shown in the chart.

**Example 1**, below, describes an Eductor A model with a 23 SLPM glass tube rotameter with metric CPI® tube connections on both the Vent Master control box and PR-1 subassembly.

**Example 2**, below, describes a Pump model with a 100 SLPM armored rotameter with imperial tube connections on the Vent Master control box and PR-1 shipped without connections.

### Examples:

1: VM - EDR - A - 23 - TFA - ZM  
 2: VM - PMP - - - 100 - ARM - - -

Vent Master	Model	Eductor Selection	Rotameter Range	Rotameter Options	PR-1 Options	Tube Connections
VM	EDR EDRNB PMP NPE	A B C Blank	0 to... 3, 8, 15, 23 & 30 0 to... 3, 8, 15, 23, 30, 40, 50, 100, 150, 200 (subject to fluid density)	Blank Glass Tube with Outlet Needle Valve ARM† Armored with Outlet Needle Valve	Blank Regulator Only TFA PR-1 with Tube Fitting Assembly (shown above)	Z Imperial CPI™ ZM Metric CPI™ A Imperial A-LOK® AM Metric A-LOK®

\* See page 103 for eductor sizing.

\*\* The rotameter range is determined by adding 2 SLPM to your MAXIMUM analyzer flow, keeping in mind abnormal flows such as calibration gas introduction, then rounding up to the next highest range available from the selection chart above.

† Armored rotameters are normally used only in applications where QC 3.1B certificates are required. The maximum pressure applied to the rotameter is -6" Hg.

## Specifications:

**Temperature Range:** -20°F to 140°F (-29°C to 50°C)

**Wetted Materials of Construction:** 316SS and Parker Parofluor o-rings (Highly Fluorinated Fluorocarbon Rubber)

3.1B Certificate of Conformance available

# Vent Master™

## Safety Instructions:

1. Be sure all connections are made properly.
2. On Eductor (EDR) models, make sure that the eductor outlet to the flare is not blocked. Blocking this flow will cause PR-1 to relieve to its vent and could cause damage to the system.
3. The standard PR-1 regulator incorporates an internal relief valve on its diaphragm. The relief valve will only open when the Vent Header pressure exceeds 7" WC. The threaded vent port on the top of the dome of PR-1 must be vented to a safe area and MUST be maintained at atmospheric pressure. ANY pressure change in the regulator's dome connection will be reflected in the Vent Header. The orientation of the dome vent connection should be horizontal or facing downward to prevent liquids from accumulating.

## Maintenance Instructions:

The Parker Vent Master™ is a mechanical system, but the only moving parts are the minor movements of the diaphragms in the regulators. Therefore, the Parker Vent Master™ is virtually maintenance free.

**Note:** The standard PR-1 incorporates a carbon steel regulator body. Its wetted components come in contact with only the Nitrogen stream, not any of the analyzer stream components. If PR-1 is to be located in a corrosive environment, contact the factory for additional options.

## Vent Master Operation and Notes:

### EDR Model

To determine pressure control functionality and PR-1 regulator operation, the following steps should be followed:

- After unit start-up and with sample flowing to the Vent Master, the flowmeter metering valve should be closed slowly until the sample flow into the header matches the flow indicated on the flowmeter. Once sample flow and the flow indicated on the flowmeter match, the header pressure gauge (PI-2) should begin to rise. The movement to higher pressure on the gauge is normal and indicates the Vent Master pressure regulator (PR-1) is operating properly. Note: Be careful not to exceed 7" WC pressure on the gauge as the standard PR-1 will vent to atmosphere. This test is identical with the pump and EDRNB models as well.
  - if the pressure rises before you reach sample flow level, then flow through the Vent Master may be too high and is approaching eductor or pump capacity
  - if the flowmeter indication is reduced below sample flow and there is no pressure rise, check for a leak between Vent Master and sample vent header
  - insure the regulator is positioned correctly and the outlet is pointing toward the vent header
- During initial start-up, there should be minimal back pressure on the system (10-20psig for the eductor model). If the Vent Master motive force gas pressure or pump discharge pressure gauges go to high pressure there could be a couple of issues.
  - The ½" discharge line must never be blocked, unless the sample system and Vent Master need to be taken out of service. The Vent Master discharge line must be minimum ½" tubing. Tubing that is reduced to less than ½" may negatively impact Vent Master performance and pressure control.

# Vent Master™

- There may be a process valve closed or in the wrong position (i.e. check valve).
  - With the discharge restricted or blocked the “pump” function of the Vent Master will be adversely affected and the vent header pressure may not be controlled.
- 
- The Vent Master is setup in the factory for -6”Hg vacuum operation. However, the Vent Master will operate at lower or higher vacuum setpoints. The key is to remember the vacuum setpoint is a measure of economizer efficiency and eductor capacity. Even at higher back pressures, the vacuum level may be reduced but the Vent Master pressure control should not be affected. To adjust the vacuum setpoint, the sample flow should be isolated from the Vent Master and only Nitrogen EDR) or natural gas (EDRNB) should be flowing to the Vent Master. Under these conditions, vacuum may be adjusted by using an 1/8” allen wrench. The control device is sensitive and there should be minimal movement to adjust vacuum. However, if there are no changes after slight controller adjustment, then there may be damage to the controller.
  - During initial setup in the field, the Vent Master “pump” can be tested for efficiency. The Vent Master discharge line can have artificial restriction via a valve of shut-off to create a rise in back pressure. There should be a steady rise in motive force gas pressure as the back pressure increases. Note: The motive force gas pressure gauge is an indirect measurement of back pressure. Pressures above 50psig indicate there is back pressure on the Vent Master outlet.
  - The header pressure gauge rapidly rises when the V-1 valve is opened. This could be the result of too much sample flow to the header or the header is being pressured. Note: During start-up, the last valve to open is V-1. The Vent Master should have vacuum set and system operating prior to opening this valve.

## Pump Model

- For all pump model Vent Masters, the pump discharge should not be blocked. This will damage the pump head and extended operation in this condition will require maintenance on the pump.

## EDRNB Model

- The EDRNB model requires instrument air along with standard motive force gas supply. The two gases are not mixed. The motive force gas is used just as the standard EDR model. The exception is the type of gas. It is most often natural gas but also could be process gas. Note: The gases used would need to be verified by the factory. The instrument air is used to drive a mechanical relay internal to the Vent Master.

# Vent Master™

## Troubleshooting:

Vent Header is over pressured (>2" WC pressure)

- Insure Vent Master flowmeter is set 2slpm higher than sample flow to header
- The sample discharge to the vent header should be from analyzer output
- The vent header can also be over pressured if back pressure of Vent Master overcomes capacity of eductor or pump

Vacuum Pressure is higher than -3" Hg

- The vacuum pressure is set at the factory to -6"Hg. However, high back pressure can also impact vacuum reading. If vacuum requires adjustment, this can be done by accessing flow controller from Vent Master enclosure. However, to change vacuum setpoint, the sample header must be isolated and back pressure on Vent Master discharge should be atmosphere or very low pressure. The adjustment to flow controller does not require aggressive adjustment.

Vent Header Pressure Above 1"WC but Stable (<7"WC)

- The PR-1 regulator does not have a range spring, therefore the diaphragm is positional and may not always indicate 1" WC. Also, if the header pressure is higher than 1" WC but remains stable during operation, the Vent Master is likely operating properly



Pressure Control  
Systems

# Vent Master™

## Conversions:

Pressure Conversion Table: (Units used in this manual)													
Units	psi	kPa	kg/cm2	cm of H2O	feet of H2O	inches of Hg	mm of HG	inches of H2O	ounces per sq. inch	Atm (atmospheres)	bar	mbar	Mpa
psi	1	6.89476	0.07031	70.3069	2.30672	2.03602	51.7149	27.6807	16	0.068046	0.6895	68.9476	0.00689
kPa	0.14504	1	0.0102	10.1975	0.33456	0.2953	7.50061	4.01472	2.3206	0.00966924	0.01	10	0.001
kg/cm2	14.2233	98.0669	1	1000.03	32.8093	28.959	735.559	393	227.573	0.9678416	0.98066	1013.25	0.09806
cm of H2O	0.01422	0.09806	0.001	1	0.03281	0.02896	0.73554	0.3937	0.22757	0.00096781	0.0098	0.9806	0.00098
feet of H2O	0.43352	2.96896	0.03048	30.48	1	0.88265	22.4192	12	6.93624	0.2949896	0.02969	29.689	0.00298
inches of Hg	0.49115	3.386389	0.03453	34.5325	1.13296	1	25.4	13.5955	7.85847	0.0334211	0.03386	33.8639	0.00386
mm of Hg	0.01934	0.13332	0.00136	1.35955	0.0446	0.03937	1	0.53526	0.30939	0.00131579	0.00133	1.33322	0.00013
inches of H2O	0.03613	0.24908	0.00254	2.54	0.0333	0.07355	1.86827	1	0.57802	0.00245825	0.00249	2.49089	0.00025
ounces per sq. inch	0.0625	0.43092	0.00439	4.39431	0.14417	0.12725	3.23218	1.73004	1	0.00425288	0.00431	4.309	0.00043
Atm (atmospheres)	14.696	101.325	1.03323	1033.26	33.8995	29.9213	760	406.794	235.136	1	1.01325	1013.25	0.1013
bar	14.5038	100	1.01972	1019.75	33.4833	29.53	750.063	401.86	232.064	0.986923	1	1000	0.1
mbar	0.0145	0.1	300102	1.019	0.00346	0.02953	0.75006	0.40146	0.23206	0.00099	0.001	1	0.0001
Mpa	145.038	1000	10.197	10197.5	334.56	295.299	7500.61	4014.74	2320.6	9.669	10	10000	1

Volume Conversion Table: (Units used in this manual)						
Units	Liters	cc (cubic centimeters)	ml (milliliters)	Ft³ (cubic feet)	Inch³ (cubic inches)	Gallon
Liters	1	1000	1000	0.03531467	61.02374	0.2641721
cc (cubic centimeters)	1000	1	1	3.53147-5	0.06102374	0.000264172
ml (milliliters)	1000	1	1	3.53147-5	0.06102374	0.000264172
Ft³ (cubic feet)	28.31685	28,316.85	28,316.85	1	1,728.00	7.480519
Inch³ (cubic inches)	0.01638706	16.38706	16.38706	0.000578704	1	0.004329004
Gallon	3.785412	3,785.41	3,785.41	0.1336806	231	1

# Vent Master™

Schematics:

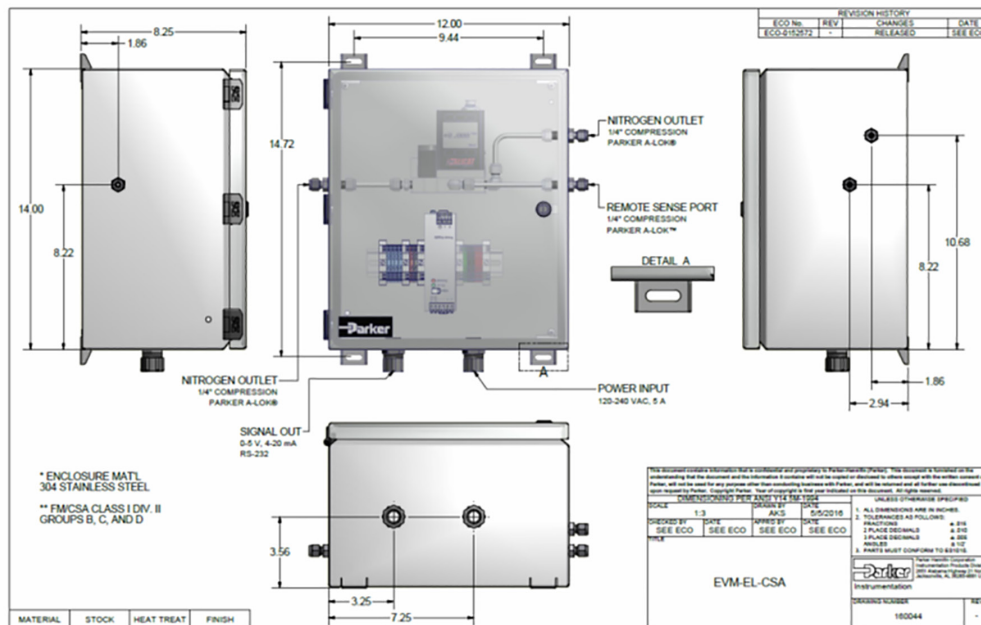

Schematics:

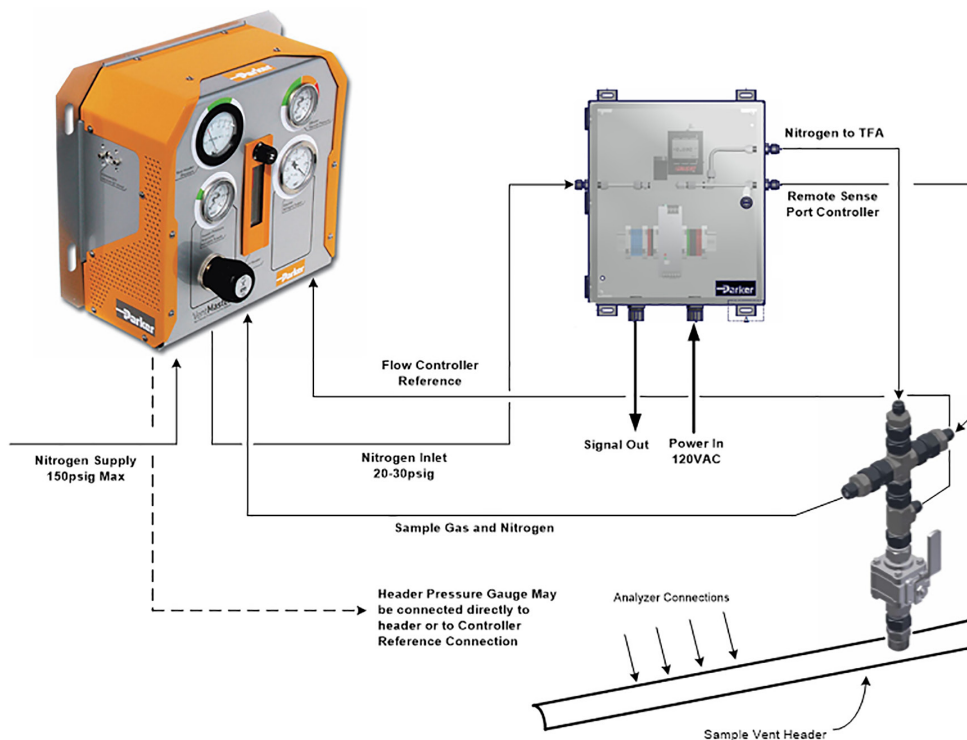

Pressure Control Systems

# Electronic Vent Master™

## Electronic Header Pressure Control System

Temperature • Flow • Pressure



### Value Proposition:

The enhanced Vent Master™ utilizes electronic pressure control that maintains the vent header at true absolute pressure eliminating errors due to barometric pressure variations.

### Features:

- Diverse package design for new and existing installations
- Rated for Hazardous area operation
- Sensor outputs available for remote monitoring of header pressure
- Designed for both corrosive and non-corrosive gas applications
- Electronic pressure controller can be mounted remotely to Vent Master™
- Pressure controller enclosure is IP65/NEMA 4X rated

### Barometric Pressure vs. Vent Header Pressure

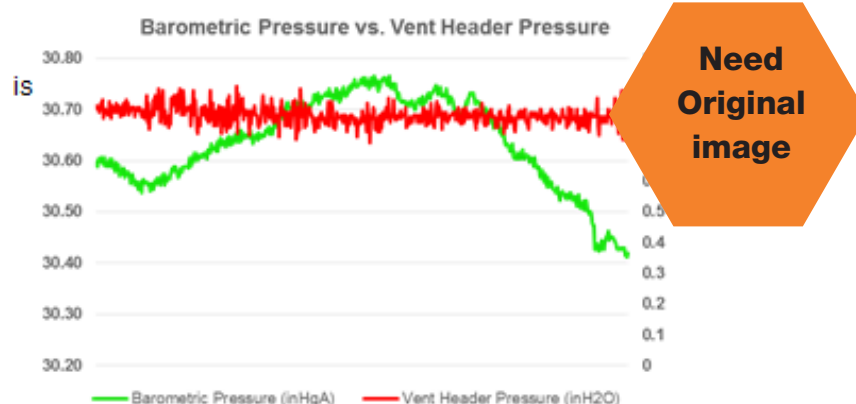

*Barometric pressure effects are eliminated*

Pressure Control Systems

# Electronic Vent Master™

Schematics:

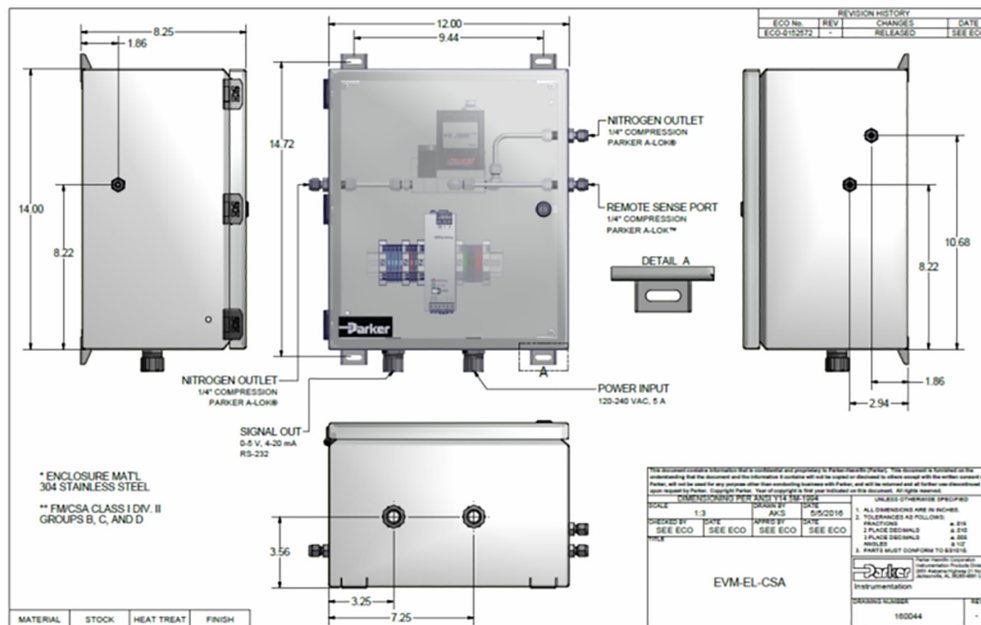

Schematics:

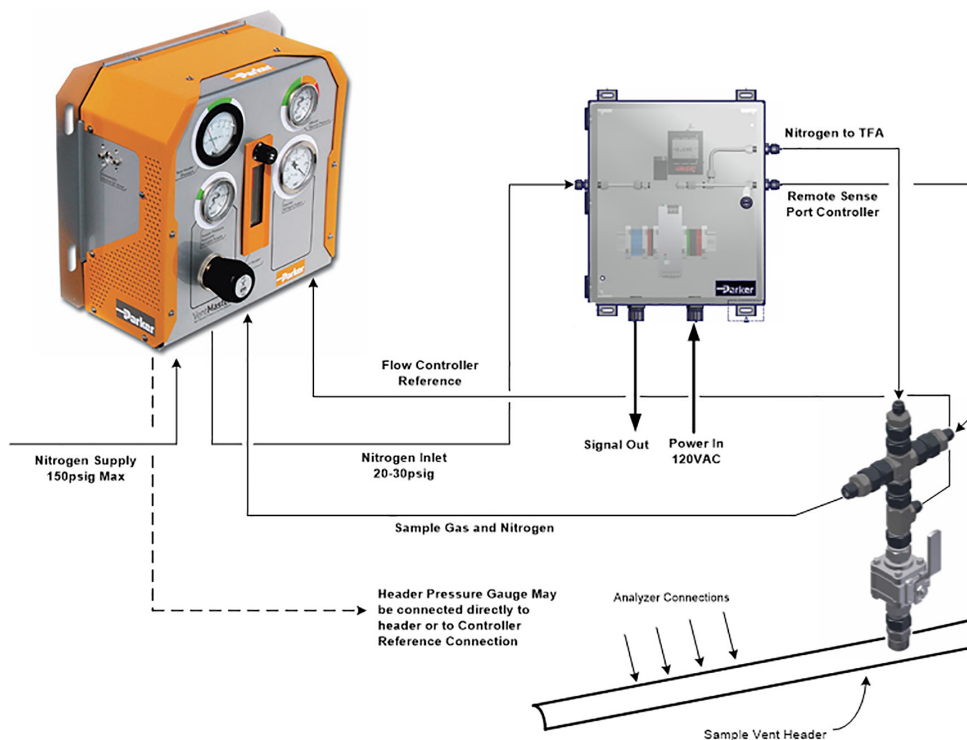

Pressure Control Systems

# Electronic Vent Master™

## Functional Start-Up:

The Parker Electronic Vent Master™ start-up is very similar to our standard mechanical model Vent Master™:

- Sample header and primary Vent Master™ isolation valves should be closed
- Nitrogen flow (pressure 50-125 psig) should be supplied and the PR-2 regulator should be set to 20-30 psig
- Power (120VAC) should be supplied to the electronics enclosure
- Vacuum should be observed on pressure gauge PI-4 (approximately 5" Hg)
- The pressure controller (inside electronics enclosure) should be adjusted (via touch panel) to pressure that is about normal atmospheric pressure expected (30-31" Hg for example)
- The vent header pressure gauge should indicate positive pressure above 0 psig but not above 1.5 psig
- Flowmeter (FI-1) should be adjusted to 2 slpm above maximum sample flow
- The electronic Vent Master™ should be in service

## Electronic Vent Master™: Operational Concept

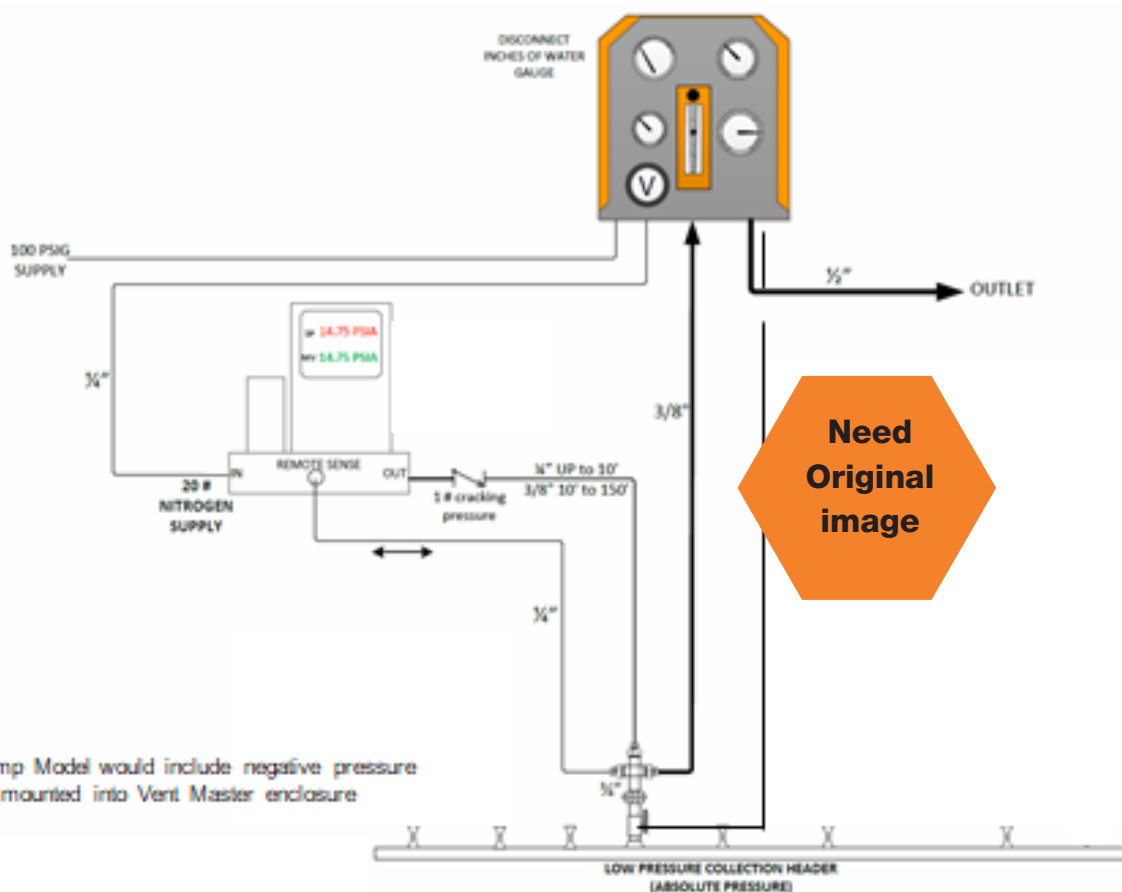

# Electronic Vent Master™

## How to Order:

The correct part number is easily derived from the following example and ordering chart. The seven product characteristics required are coded as shown in the chart.

**Example 1:** EVM-EDR-B-8-ARM-TFA-A below, describes an Electronic Vent Master™ with a “B” sized Educator, 8slpm Armored Flowmeter, Tube Fitting Assembly (TFA) and A-LOK® compression tube fittings.

**Example 2:** EVM-PMP-23-TFA-Z below, describes an Electronic Vent Master™ with a pump, 23slpm Glass Tube Flowmeter, Tube Fitting Assembly (TFA) and CPI™ compression Tube Fitting

### Examples:

1: EVM - EDR - B - 8 - ARM - TFA - A  
 2: EVM - PMP - - - 23 - - TFA - Z

		Educator Selection	Rotameter Range	Rotameter Options	PR-1 Options	Tube Connections
Vent Master	Model	Educator Selection*	Rotameter Range (SLPM)**	Rotameter Options	PR-1 Options	Tube Connections
EVM	EDR	A B C	0 to... 3, 8, 15, 23, 30 & 40	<b>Blank</b> Glass Tube with Outlet Needle Valve	<b>Blank</b> No TFA <b>TFA</b> PR-1 with Tube Fitting Assembly (shown above)	<b>Z</b> Imperial CPI™ <b>ZM</b> Metric CPI™ <b>A</b> Imperial A-LOK® <b>AM</b> Metric A-LOK®
	PMP	<b>Blank</b>	0 to... 8, 15, 23, 50 & 100	<b>ARM†</b> Armored with Outlet Needle Valve		

\* See page 103 for educator sizing.

\*\* The rotameter range is determined by adding 2 SLPM to your MAXIMUM analyzer flow, keeping in mind abnormal flows such as calibration gas introduction, then rounding up to the next highest range available from the selection chart above.

**KIT: EVM - Fitting Type (Z, ZM, A or AM):** This kit is used to retrofit existing Vent Master™ units for electronic operation

## Specifications:

**Temperature Range:** -29°F to 140°F (-34°C to 50°C)

**Wetted Materials of Construction:** 316SS and Parker Parofluor o-rings (Highly Fluorinated Fluorocarbon Rubber)

# Electronic Vent Master™

## Safety Instructions:

1. Be sure all connections are made properly.
2. On Eductor (EDR) models, make sure that the eductor outlet to the flare is not blocked. Blocking this flow will cause PR-1 to relieve to its vent and could cause damage to the system.
3. The standard PR-1 regulator incorporates an internal relief valve on its diaphragm. The relief valve will only open when the Vent Header pressure exceeds 7" WC. The threaded vent port on the top of the dome of PR-1 must be vented to a safe area and MUST be maintained at atmospheric pressure. ANY pressure change in the regulator's dome connection will be reflected in the Vent Header. The orientation of the dome vent connection should be horizontal or facing downward to prevent liquids from accumulating.

## Maintenance Instructions:

The Parker Vent Master™ is a mechanical system, but the only moving parts are the minor movements of the diaphragms in the regulators. Therefore, the Parker Vent Master™ is virtually maintenance free.

**Note:** The standard PR-1 incorporates a carbon steel regulator body. Its wetted components come in contact with only the Nitrogen stream, not any of the analyzer stream components. If PR-1 is to be located in a corrosive environment, contact the factory for additional options.

## Vent Master Operation and Notes:

### EDR Model

To determine pressure control functionality and PR-1 regulator operation, the following steps should be followed:

- After unit start-up and with sample flowing to the Vent Master, the flowmeter metering valve should be closed slowly until the sample flow into the header matches the flow indicated on the flowmeter. Once sample flow and the flow indicated on the flowmeter match, the header pressure gauge (PI-2) should begin to rise. The movement to higher pressure on the gauge is normal and indicates the Vent Master pressure regulator (PR-1) is operating properly. Note: Be careful not to exceed 7" WC pressure on the gauge as the standard PR-1 will vent to atmosphere. This test is identical with the pump and EDNRB models as well.
  - if the pressure rises before you reach sample flow level, then flow through the Vent Master may be too high and is approaching eductor or pump capacity
  - if the flowmeter indication is reduced below sample flow and there is no pressure rise, check for a leak between Vent Master and sample vent header
  - insure the regulator is positioned correctly and the outlet is pointing toward the vent header
- During initial start-up, there should be minimal back pressure on the system (10-20psig for the eductor model). If the Vent Master motive force gas pressure or pump discharge pressure gauges go to high pressure there could be a couple of issues.
  - The ½" discharge line must never be blocked, unless the sample system and Vent Master need to be taken out of service. The Vent Master discharge line must be minimum ½" tubing. Tubing that is reduced to less than ½" may negatively impact Vent Master performance and pressure control.

# Electronic Vent Master™

- There may be a process valve closed or in the wrong position (i.e. check valve).
- With the discharge restricted or blocked the “pump” function of the Vent Master will be adversely affected and the vent header pressure may not be controlled.
- The Vent Master is setup in the factory for -6”Hg vacuum operation. However, the Vent Master will operate at lower or higher vacuum setpoints. The key is to remember the vacuum setpoint is a measure of economizer efficiency and eductor capacity. Even at higher back pressures, the vacuum level may be reduced but the Vent Master pressure control should not be affected. To adjust the vacuum setpoint, the sample flow should be isolated from the Vent Master and only Nitrogen EDR) or natural gas (EDRNB) should be flowing to the Vent Master. Under these conditions, vacuum may be adjusted by using an 1/8” allen wrench. The control device is sensitive and there should be minimal movement to adjust vacuum. However, if there are no changes after slight controller adjustment, then there may be damage to the controller.
- During initial setup in the field, the Vent Master “pump” can be tested for efficiency. The Vent Master discharge line can have artificial restriction via a valve of shut-off to create a rise in back pressure. There should be a steady rise in motive force gas pressure as the back pressure increases. Note: The motive force gas pressure gauge is an indirect measurement of back pressure. Pressures above 50psig indicate there is back pressure on the Vent Master outlet.
- The header pressure gauge rapidly rises when the V-1 valve is opened. This could be the result of too much sample flow to the header or the header is being pressured. Note: During start-up, the last valve to open is V-1. The Vent Master should have vacuum set and system operating prior to opening this valve.

## Pump Model

- For all pump model Vent Masters, the pump discharge should not be blocked. This will damage the pump head and extended operation in this condition will require maintenance on the pump.

## EDRNB Model

- The EDRNB model requires instrument air along with standard motive force gas supply. The two gases are not mixed. The motive force gas is used just as the standard EDR model. The exception is the type of gas. It is most often natural gas but also could be process gas. Note: The gases used would need to be verified by the factory. The instrument air is used to drive a mechanical relay internal to the Vent Master.

# Electronic Vent Master™

## Troubleshooting:

Vent Header is over pressured (>2" WC pressure)

- Insure Vent Master flowmeter is set 2slpm higher than sample flow to header
- The sample discharge to the vent header should be from analyzer output
- The vent header can also be over pressured if back pressure of Vent Master overcomes capacity of eductor or pump

Vacuum Pressure is higher than -3" Hg

- The vacuum pressure is set at the factory to -6"Hg. However, high back pressure can also impact vacuum reading. If vacuum requires adjustment, this can be done by accessing flow controller from Vent Master enclosure. However, to change vacuum setpoint, the sample header must be isolated and back pressure on Vent Master discharge should be atmosphere or very low pressure. The adjustment to flow controller does not require aggressive adjustment.

Vent Header Pressure Above 1"WC but Stable (<7"WC)

- The PR-1 regulator does not have a range spring, therefore the diaphragm is positional and may not always indicate 1" WC. Also, if the header pressure is higher than 1" WC but remains stable during operation, the Vent Master is likely operating properly



# Electronic Vent Master™

Eductor Model (EDR) - Header with Liquids:

## EDUCTOR MODEL (EDR)

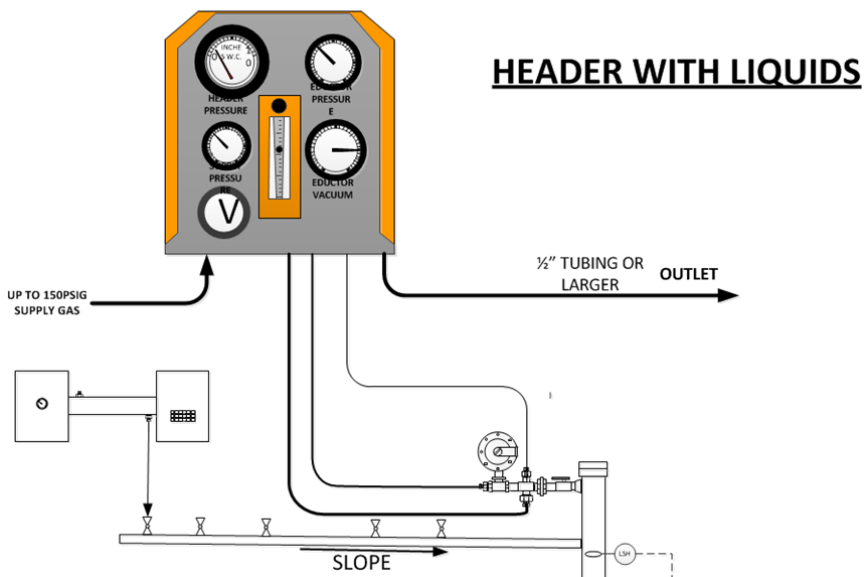

Eductor Model (EDR) - Header with Liquids:

## Negative Pressure Control

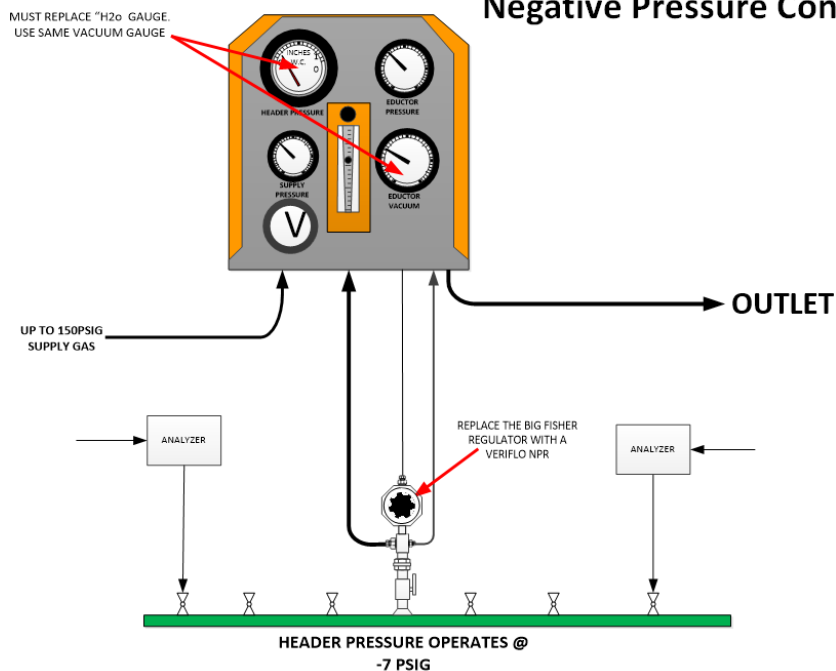

Pressure Control  
Systems

# Analyzer Pressure Regulation and Vent Recovery System

Unparalleled pressure and flow stability

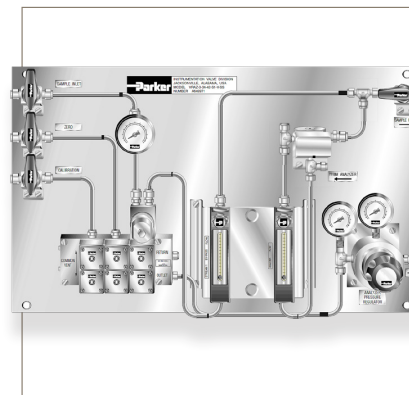

## Value Proposition:

The Parker Analyzer Pressure Regulation and Vent Recovery System automatically and continuously adjusts for variations in gas supply pressures and flows. This system has been engineered to meet the requirement of continuous analyzers designed to operate at constant pressure in order to provide accurate analyses of gases. The combination of pressure and flow regulation provides the required stability even with greatly varying inlet and outlet pressures.

## Product Features:

- Designed for a zero, a calibration, and up to two sample streams
- Capabilities
  - Stream switching
  - Sample filtering
  - Flow and pressure regulation
- Regulator controls analyzer pressure
- Metering valves control
  - Analyzer flow
  - Stream by-pass flow
- Flowmeters indicate stability of
  - Analyzer flow
  - Stream by-pass flow
- Pressure gauges indicate
  - Sample inlet pressure
  - Pressure to the analyzer
  - Pressure from the filter
- Utilizes Parker
  - R-Max™ Stream Switching System
  - MB Series Ball Valves
  - HR Series Metering Valves
  - IR5000 Pressure Regulator
  - SC Flow Controller
  - Balston® Particulate Filtration
  - CPI™ Connectors
- 100% Factory Tested
- Patent Pending
- Custom Engineered Systems Available

## Operating Conditions:

- Pressure Rating:
  - 200 psig (14 bar) maximum
- Temperature Rating:
  - Media -40 °F to 200 °F (-40 °C to 93 °C)
  - Ambient -40 °F to 140 °F (-40 °C to 60 °C)

## Function Performance:

Pressure Ratings:

IR5000 Pressure Regulator - 3500 psig (241 bar)

MB Series Ball Valve - 3000 psig (207 bar)

R-Max™ Stream Switching System - 500 psig (34 bar)

HR Series Metering Valve - 250 psig (17 bar)

Flowmeter - 200 psig (14 bar)

SC Flow Controller - 150 psig (10 bar)

# Analyzer Pressure Regulation and Vent Recovery System

## Material of Construction:\*

Wetted	
<b>R-Max™ System</b>	
Base, Body and Stems	316L Stainless Steel
Upper and Lower Seats	PCTFE
Seals	Fluorocarbon Rubber
<b>IR5000 Regulator</b>	
Body	316L Stainless Steel
Diaphragm	Hastelloy® C-22
Compression Member	Inconel®
Poppet	Elgiloy®
Poppet Spring	Inconel®
Carrier	Stainless Steel
Seat	PCTFE
Back-up O-Ring	Fluorocarbon Rubber
Inlet Screen/Filter	316L Stainless Steel
<b>MB Ball Valves</b>	
Body and Stem	316L Stainless Steel
Seat/Packing	Perfluoroalkoxy (PFA)
<b>HR Metering Valves</b>	
Cartridge Components	316 Stainless Steel
Orifice Liner	Mica Filled PTFE
Stem Seals	Fluorocarbon Rubber
<b>SC Controller</b>	
Body and Piston	316L Stainless Steel
Seat and Seals	Fluorocarbon Rubber
Diaphragm	Hastelloy® C-22
<b>Flowmeters</b>	
Body	316 Stainless Steel
Tube	Borosilicate Glass
Float	Glass
Float Stops	PTFE
<b>Gauges</b>	
Body	316 Stainless Steel
Bourdon Tube	316 Stainless Steel
<b>Fittings</b>	
	316 Stainless Steel
<b>Tubing</b>	
	316 Stainless Steel

Non-Wetted	
<b>Fittings</b>	304 Stainless Steel
<b>Brackets</b>	304 Stainless Steel
<b>Hardware</b>	Stainless Steel
<b>Operating Handles</b>	ABS Plastic, Nylon 6/6
<b>Gauges and Flowmeter Shields</b>	Polycarbonate

\* Materials of construction for stainless steel systems.

Consult factory for optional materials of construction.  
Hastelloy C-22 is a registered trademark of Haynes International, Inc.  
Inconel is a registered trademark of Inco Alloys International  
Elgiloy is a registered trademark of Elgiloy Company

## Performance Example 1 - Varying Inlet Pressure with Constant Outlet Pressure

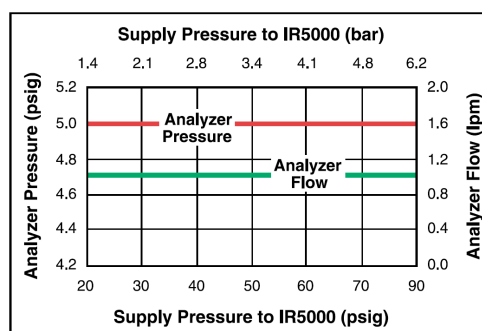

Analyzer Pressure set to 5 psig (0.3 bar);  
Supply Pressure varied from 20 to 90 psig (1.4 to 6.2 bar)

## Performance Example 2 - Varying Outlet Pressure with Constant Inlet Pressure

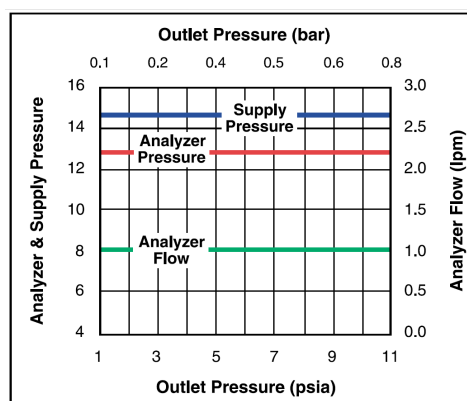

Analyzer Pressure set to 12.7 psia (0.87 bar);  
Supply Pressure set to 14.5 psia (1.01 bar);  
Outlet Pressure varied from 1 to 11 psia (0.07 to 0.76 bar)

# Analyzer Pressure Regulation and Vent Recovery System

## Typical Two Stream Vent Recovery System

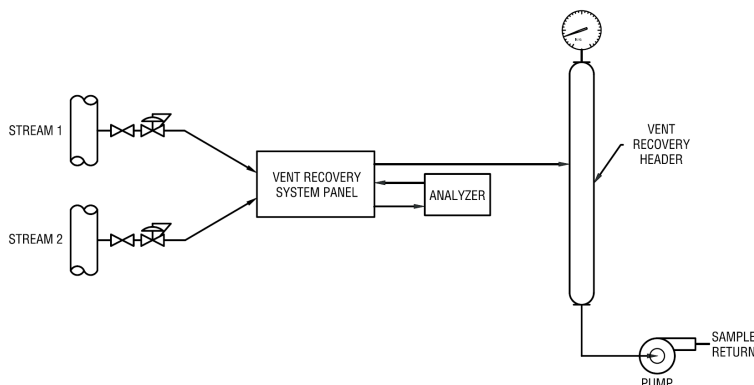

### Ordering Information:

Building a Part Number: <i>Example: VRAZ3-34-42-S1-V-SS</i>															
Example Part Number:	VRA	Z	3	-	3	4	-	4	2	-	S1	-	V	-	SS
Ordering Parameters/Options:	Series	System Options	Number of Streams		Inlet Pressure Gauge	Pressure Regulator		By-Pass Flowmeter Range (LPM)	Analyzer Flowmeter Range (LPM)		By-Pass Filter		Seal Material		Component Material
Table Reference: (see below)	A	B	C		D	E		F	G		H		H		H

A - Series	
VRA	Automatic Stream Switch
VRM	Manual Stream Switch

B - System Options	
A	Integral Aspirator
B	Filter Purge Valve
C	Aspirator & Filter Purge Valve
Z	None of the above

C - Number of Streams	
3	Three
4	Four

D - Inlet Pressure Gauge	
0	30psig
1	60 psig
2	100 psig
3	200 psig

E - Pressure Regulator	
0	2 Ports (No X required for gauges, inlet and outlet ports only)
1	3 Ports (One X for gauge port)
2	3 Ports (One X for gauge port)

F - Inlet Gauge	
05	0-15 psig
OL	0-60 psig
01	0-100 psig
X	No gauge (Gauges may be provided by local Parker Distributor)

G - Port Style	
4	1/4" NPT Female (All Gauge ports are 1/4" NPT Female)

H - Optional Features	
M	Metal Knob (Black)
06	0.06 C <sub>v</sub>
1	0.1 C <sub>v</sub>
C3	Cleaned for Oxygen Service (Oxygen Cleaning Requirements in accordance with Parker Specification ES8003)

**Note:**

**Panel Mount Option:**  
Order Panel Mount Nut Ring (PN: IR4-Panel-Nut-B-NP) as separate line item

**Vent Muffler Option:**  
Vent Muffler (PN: Muffler-2F-Bronze) as separate line item.

**Parker Instrumentation Products Division reserves the right to plug NPT ports**

# IntraFlow™

## Compliant Modular Systems, ISA/ANSI SP76.00.02

Flow Control • Maximum Flexibility

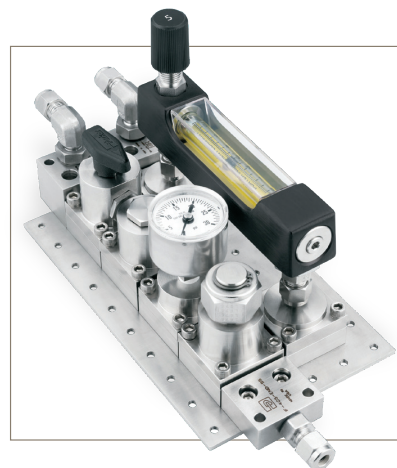

### Value Proposition:

Parker IntraFlow™ substrate fittings have been developed specifically for analytical, lab and other complex general purpose instrumentation flow control systems. ISA/ANSI SP76.00.02 compliant, Parker IntraFlow™ fittings provide maximum flexibility with minimal space requirements. All flowpaths, regardless of direction, are maintained on a single plane within the system as there are no lower level manifold blocks required. Contiguous fitting flow paths are intra-connected with slip fit pressure connectors, while a threaded pegboard provides connection force and rigidity when fittings are mounted with cap screws. System assembly couldn't be simpler: a 5/32" hex head wrench is all you need to build with Parker IntraFlow™.

### Features:

- System size is reduced as much as 75% compared with conventionally plumbed systems, drastically reducing panel space, internal volume and purge times
- Compliant with ISA/ANSI SP76.00.02 open architecture standards
- Complex system assembly was never easier! No tube benders or cutters required, and no welding. All that's needed to assemble is a 5/32" hex head wrench!
- Every component on your Parker IntraFlow™ system can be reused when upgrading with emerging NeSSI Generation 2 & 3 technologies
- All flow paths are on the same plane: Parker IntraFlow™ eliminates lower level manifolds to minimize system weight and leak potentials
- Whether mounting a fitting to the standard 1/8" pegboard or a valve to the fitting, the same 10-32 x 1/2" SHCS is the only screw required

### Specifications:

- **Pressure Rating:** Vacuum to 500 psig (34 bar) CWP
- **Temperature Ratings:**
  - Fluorocarbon Rubber  
-15°F to 400°F (-26°C to 204°C)
  - Buna-N Rubber  
-30°F to 275°F (-34°C to 135°C)
  - Ethylene Propylene Rubber  
-70°F to 275°F (-57°C to 135°C)
  - Neoprene Rubber  
-45°F to 250°F (-43°C to 121°C)
  - Highly Fluorinated Fluorocarbon Rubber  
-25°F to 200°F (-32°C to 93°C)

## Heated Systems

Conventionally fabricated heated systems typically utilize convection heaters inside an insulated enclosure. Parker IntraFlow™ systems deliver the heat through conduction directly where it's needed: within 5/32" of the actual fluid flowpath. Replacing the standard 1/8" thick pegboard with a 1/2" thick internally channeled plate, electric heat cartridges are easily inserted to heat fluid to desired temperatures. A steam heat ported pegboard is also available.

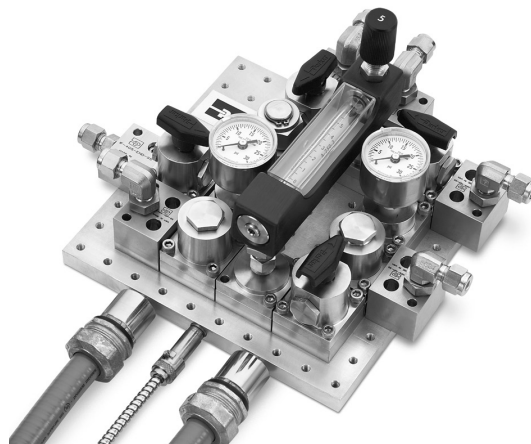

### Features:

- Heated pegboard is interchangeable with non-heated pegboard and easily converted
- Heat is applied through conduction directly to the base of the fitting, increasing heat efficiency
- Commercially available standard general purpose heater cartridges insert and connect directly into the pegboard via 1/8" FNPT connections
- Class I, Division 2 compliant cartridges are available with direct connect conduit connections
- Parker Multitube® heat traced tube bundles are available for sample delivery to IntraFlow™ systems. Multi-zone controllers are capable of integrating all control at one source
- Steam heat channeled pegboards are also available

### Electrical Specifications:

- 120 or 240 VAC, 50/60 Hz
- 40, 50, 75 watt cartridges
- General purpose 1/4" nominal cartridge with 1/8" FNPT threaded connection

### Stream Specifications:

- 1/8" FNPT supply and return connection ports
- 600 psig (41 bar) maximum steam pressure
- Maximum temperature capability determined by system o-ring selection

# IntraFlow™

## Fittings

All Parker IntraFlow™ fittings are permanently marked with the part number, flow schematic and material heat traceability code for easy identification during assembly and when servicing in the field. 1/8" diameter internal flow paths are precision machined at the intersections to minimize dead volume. Slip fit counterbores with a lead-in chamfer retain intra-connecting pressure connectors.



Interface o-rings supplied separately on page 6.

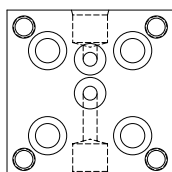

S-A1B3

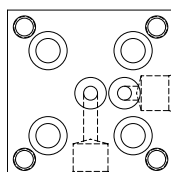

E-A1B4

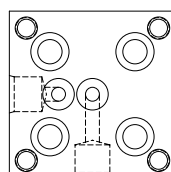

E-A1B2

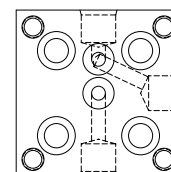

SE-A1B34

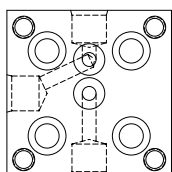

SE-A1B23

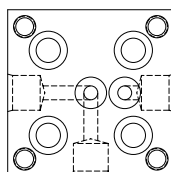

ES-A12B4

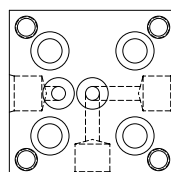

ES-A14B2

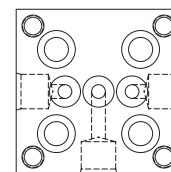

T-A1B24

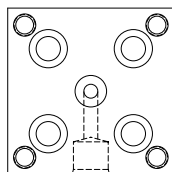

S-A1B0

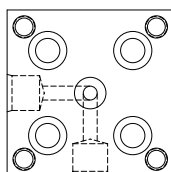

E-A12B0

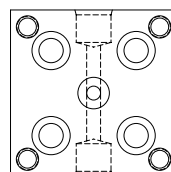

S-A13B0

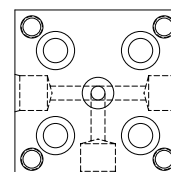

T-A134B0

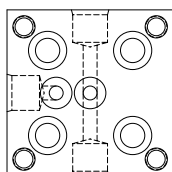

T-A13B2

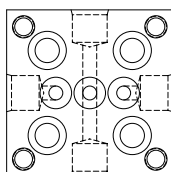

T-A13B24

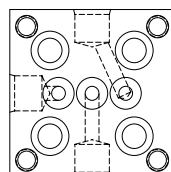

TR-A1B23

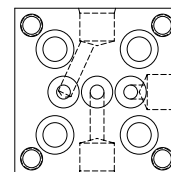

TL-A1B34

### How to Order Parker IntraFlow™ Fittings

Example	<b>IF</b>	-	<b>T-A13B2</b>	-	<b>SS</b>
	Product		Generic and Defined Flowpath		Materials
	<b>IF</b> = IntraFlow		(See Chart Above)		<b>SS</b> = 316 Stainless Steel

Example Part Number: **IF-T-A13B2-SS**

# IntraFlow™

## Field Connectors

Connecting Parker IntraFlow™ systems to pressure sources is simply accomplished with a field connector. Both top and end access connections are available in 1/8" FNPT, 1/4" SAE and 1/4" Inverted CPI™ & A-LOK®.

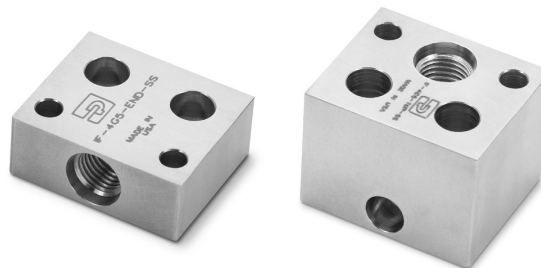

End Access

Top Access

### How to Order Field Connectors

Example	IF	-	2F	-	TOP	-	SS
	Product		Field Connection		Access		Material
	IF = IntraFlow		2F = 1/8" FNPT 4G5 = 1/4" SAE 4Z7 = 1/4" Inverted CPI™ 4A7 = 1/4" Inverted A-LOK®		TOP = (Access) END = (Access)		SS = 316 Stainless Steel

Example Part Number: IF-2F-TOP-SS

## Pressure Connectors

Slip-fit Pressure Connectors provide flowpath intra-connectivity between Parker IntraFlow™ fittings. Pressure Connectors are fully assembled with AS568B standard size 2-008 o-rings and are available in both standard and jumper lengths (for systems with flow requirements between non-contiguous fittings). Orifice is 1/8" and various elastomers are available.



### How to Order Pressure Connectors

Example	IF	-	CONNECTOR	-	V	-	SS
	Product		Component		Elastomer		Length
	IF = IntraFlow		Connector		V = Fluorocarbon Rubber EPR = Ethylene Propylene Rubber BN = Buna-N Rubber NE = Neoprene Rubber KZ = Highly Fluorinated Fluorocarbon		Blank = Standard 1-1 = Block Jumper
							SS = 316 Stainless Steel

Example Part Number: IF-CONNECTOR-V-SS

## Mounting Screws

Parker IntraFlow™ requires only a single size screw to assemble an entire system. 10-32 UNF x 1/2" SHCS kits are available in bag quantities of 100. Material is 18-8 Stainless Steel.

Part number: 10-32x1/2-SHC-SCREW-100



# IntraFlow™

## Interface O-rings

AS568B standard 2-007 o-rings are placed in the counterbores of each Parker IntraFlow™ fitting, providing a seal with the mating surface mount component. Parker's inPHorm O-Ring Material Selection Software takes the guess work out of media compatibility with o-ring compounds. Elastomer compound recommendations are output from media descriptions (single & multiple components) and temperature inputs.



### How to Order Interface O-rings

Example	IF	-	ORING	-	V	-	250
	Product		Component		Elastomer		Bag Quantity
	IF = IntraFlow		Connector		V = Fluorocarbon Rubber		50
					EPR = Ethylene Propylene Rubber		100
					BN = Buna-N Rubber		250
					NE = Neoprene Rubber		500
					KZ = Highly Fluorinated Fluorocarbon		10
							25
							50
							100

Example Part Number: IF-ORING-V-250

## Pegboards & Brackets

A wide range of heated and non-heated pegboard sizes are available to build your Parker IntraFlow™ system. Odd shaped or oversize pegboards can be created by overlapping IntraFlow™ fittings across 2 standard pegboards. Heated pegboards are machined from ASTM 6061 aluminum while non-heated pegboards are machined from ASTM 304 stainless steel. Stainless steel brackets (minimum of 4 recommended) bolted at pegboard corner locations elevate the system for mounting to a backplane. Heated pegboards have holes bored in the end of the plate for either electric heater cartridges, thermocouples or steam. In all cases, 1/8" FNPT threads provide the connection port.



### How to Order Pegboards

Example	IF	-	PEGBOARD	-	6x10	-	ELC
	Product		Component		Size (hole matrix)		Style
	IF = IntraFlow		PEGBOARD		2x2		Blank = Non-Heated
					2x4		
				2x6			
					6x10		Blank = Non-Heated ELEC = Cartridge Heated STM = Stream Heated
					8x8		
					8x10		
					8x14		
					10x10		
					12x12		

Example Part Number: IF-PEGBOARD-6x10-ELC

### Pegboard Mounting Bracket P/N's:

IF-MTGBRKT (non-heated pegboard)  
IF-MTGBRKT-HEAT (heated pegboard)  
(includes screws; 9/32" through hole for mounting to backplane).

Sample Systems

# IntraFlow™

## Adapters & Caps

Surface mount adapters to common fitting connections are available for makeup to pressure indicators, thermocouples, sensors and other commercially available devices. Adapters are available in both 1 (-1P) or 2 (-2P) flow path configurations as shown in the drawings. Any of the -2P adapters may be plugged to provide a flow-through cap over an IntraFlow™ fitting planned for a future system function.

### How to Order Adapters

Example	IF	-	2F	-	2P	-	SS
	Product		Connection		Ports		Material
	IF = IntraFlow		<b>2A</b> = 1/8" Inverted A-LOK® <b>2F</b> = 1/8" FNPT <b>2Z</b> = 1/8" Inverted CPI™ <b>4A</b> = 1/4" Inverted A-LOK® <b>4F</b> = 1/4" FNPT <b>4V</b> = 1/4" Male VacuSeal <b>4V1</b> = 1/4" Female VacuSeal <b>4Z</b> = 1/4" CPI™		<b>1P</b> = Single Port <b>2P</b> = Double Port		<b>SS</b> = 316 Stainless Steel

Example Part Number: IF-2F-2P-SS

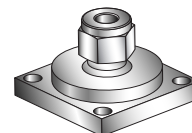

Compression Fitting



1 Port Adapter Connector



2 Port Adapter Connector

## Rotometer Adapters

SP76.00.02 specifications require a 1.53" centerline spacing between all substrate fittings. Parker Rotometer adapters have 1/4" tube stubs machined 0.045" offset of the SP76.00.02 footprint to accommodate 4-1/2" rotometer port centerlines.

Part Number: IF-4TA-1P-OFFSET045-SS

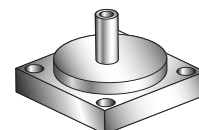

Offset Tube Stub

## Ball Valves

### How to Order B Series Ball Valves

Example	IF	-	B2L	-	J	-	V	-	SS
	Port		Series		Seat		Seal		Material
	IF = IntraFlow		<b>B2L</b> = 2 Way <b>B2X</b> = 3 Way		<b>J</b> = PTFE <b>J2</b> = PCTFE		<b>V</b> = Fluorocarbon Rubber <b>EPR</b> = Ethylene Propylene <b>BN</b> = Buna-N Rubber		<b>SS</b> = 316 Stainless Steel

Example Part Number: IF-B2L-J-V-SS

Standard handle is black mini-lever. Other handle options:

#### Colored Lever Handles:

Add the designator corresponding to the correct handle as a suffix to the part number:  
**W** – white, **B** – blue, **G** – green, **R** – red, **Y** – yellow

Example: IF-B2LJ-V-SS-G

#### Colored Round Handles:

Add the designator corresponding to the correct handle as a suffix to the part number:  
**S** – black, **S-W** – white, **S-B** – blue, **S-G** – green, **S-R** – red, **S-Y** – yellow

Example: IF-B2LJ-V-SS-S-G

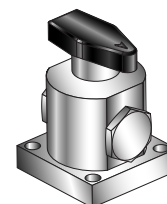

B2X Ball Valve

**B Series Ball Valve**  
 Reference Catalog 4121-B

# IntraFlow™

## 3-Way Air Actuated Valves

How to Order R-Max 3-Way Valves

IF	-	R2S	-	K	-	V	-	SS
Port		Series		Seat		Seal		Material
IF = IntraFlow		B2L = 2 Way B2X = 3 Way		K = PCTFE		V = Fluorocarbon Rubber EPR = Ethylene Propylene BN = Buna-N Rubber NE = Neoprene Rubber KZ = Highly Fluorinated Fluorocarbon		SS = 316 Stainless Steel

Example Part Number: IF-R2S-K-V-SS

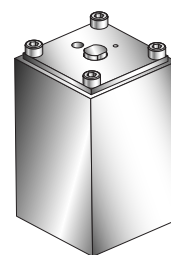

Regulator (45300792)

**R-Max Air Actuated 3-Way Valve**  
Reference Catalog 4140-R

## Inline & Fast Bypass Filters

How to Order FT4 Inline Filters

IF	-	FT4	-	10	-	V	-	SS
Port		Series		Seal		Filter Type		Material
IF = IntraFlow		FT4		K = PCTFE		V = Fluorocarbon Rubber EPR = Ethylene Propylene BN = Buna-N Rubber NE = Neoprene Rubber KZ = Highly Fluorinated Fluorocarbon		SS = 316 Stainless Steel

Example Part Number: IF-FT4-10-V-SS

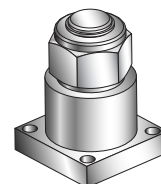

FT4 Filter

**Inline Sintered Metal Filters**  
Reference Catalog 4130-FT

How to Order Inline & Fast Bypass Filters

IF	-	FR2	-	V	-	P	93	-	SS
Port		Series		Seal		Filter Type	Balston P & C	Sintered Metal	Material
IF = IntraFlow		FR2 = Inline FR3 = Bypass		V = Fluorocarbon Rubber EPR = Ethylene Propylene BN = Buna-N Rubber NE = Neoprene Rubber KZ = Highly Fluorinated Fluorocarbon		P = Particulate C = Coalescing S = Sintered 316SS	93 = 93% Microfibre 99 = 99% Microfibre	1 = 1 µm 5 = 5 µm 10 = 10 µm 50 = 50 µm 100 = 100 µm 250 = 250 µm 450 = 450 µm	SS = 316 Stainless Steel

Example Part Number: IF-FR2-V-P93-SS

**Inline & Fast Bypass Filters**  
Reference Catalog IP-B

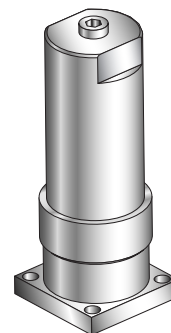

FR2 Balston Filter

Sample  
Systems

# IntraFlow™

## Check Valves

How to Order CO Series Check Valves

IF	-	CO4	-	5	-	V	-	SS
Port		Series		Crack Pressure		Seal		Material
IF = IntraFlow		CO4		1/3 psi 1 psi 5 psi 10 psi 25 psi 50 psi 75 psi 100 psi		V = Fluorocarbon Rubber EPR = Ethylene Propylene BN = Buna-N Rubber KZ = Highly Fluorinated Fluorocarbon		SS = 316 Stainless Steel

Example Part Number: IF-CO4-5-V-SS

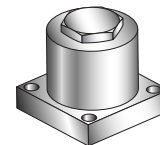

FT4 FILTER

**CO SERIES Check Valve**  
Reference Catalog 4130-CO

## Needle Valves

How to Order H Series Needle Valves

IF	-	H4L	-	K	-	V	-	SS
Port		Series		Seat		Seal		Material
IF = IntraFlow		H4L		R = Blunt (30°) N = Needle (2-1/2°) K = PCTFE		Blank = PTFE EPR = Ethylene Propylene BN = Buna-N Rubber V = Fluorocarbon Rubber		SS = 316 Stainless Steel

Example Part Number: IF-H4LK-V-SS

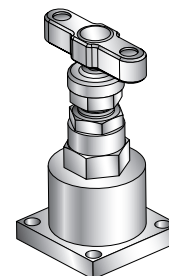

**H SERIES Needle Valve**  
Reference Catalog 4190-HV

## VQ Series Toggle Needle Valves

How to Order VQ Series Toggle Valves

IF	-	V4LO	-	K	-	V	-	SS
Port		Series		Seat		Seal		Material
IF = IntraFlow		V4LO		Blank = PTFE K = PCTFE		Blank = PTFE EPR = Ethylene Propylene BN = Buna-N Rubber V = Fluorocarbon Rubber		SS = 316 Stainless Steel

Example Part Number: IF-V4LOK-V-SS

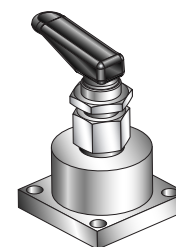

**VQ SERIES Toggle Valve**  
Reference Catalog 4110-VQ

# IntraFlow™

## HR Series Metering Needle Valves

How to Order HR Series Metering Valves

IF	-	H3L	-	V	-	SS	-	NS
Port		Series	Max. Cv	Seal		Material		Handle Type
IF = IntraFlow		H0L H1L H2L <b>H3L</b> H4L H5L H6L	.0004 .0070 .0140 .200 .300 .470 .1180	<b>Blank</b> = PTFE <b>EPR</b> = Ethylene Propylene <b>BN</b> = Buna-N Rubber <b>V</b> = Fluorocarbon Rubber <b>KZ</b> = Highly Fluorinated Fluorocarbon		<b>SS</b> = 316 Stainless Steel		<b>K</b> = Knurled <b>TC</b> = Turns Counter <b>NS</b> = No Handle (slotted stem)

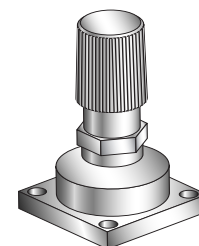

**HR SERIES Metering Valve**  
Reference Catalog 4170-HR

Example Part Number: IF-H3LV-SS-NS

## Relief Valves

How to Order RL Series Relief Valves

IF	-	RL4	-	V	-	T	-	SS	-	MN	-	KA
Port		Series		Seal		Backup Rings		Material		Actuation		Spring
IF = IntraFlow		<b>RL4</b>		<b>NE</b> = Neoprene Rubber <b>EPR</b> = Ethylene Propylene <b>BN</b> = Buna-N Rubber <b>V</b> = Fluorocarbon Rubber <b>KZ</b> = Highly Fluorinated Fluorocarbon		<b>T</b> = PTFE		<b>SS</b> = 316 Stainless Steel		<b>Blank</b> = Standard  <b>MN</b> = Manual Override		<b>KA</b> = 10-25 psig <b>KB</b> = 25-50 psig <b>KC</b> = 50-100 psig <b>KD</b> = 100-150 psig <b>KE</b> = 150-225 psig <b>KF</b> = 10-225 psig <b>KG</b> = 225-400 psig

Example Part Number: IF-RL4V-T-SS-MN-KA

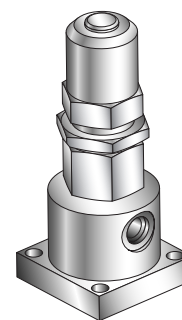

**RL SERIES Relief Valve**  
Reference Catalog 4131-RL

Sample Systems

# IntraFlow™

## Quick Disconnects

How to Order FS Series Non-Spill Couplers

IF	-	FS	-	251	-	V	-	SS	-	1060
Port		Series		Seat		Seal		Material		Key/Color Code (Optional)
IF = IntraFlow		FS		251 = Coupler 252 = Nipple		V = Fluorocarbon Rubber EPR = Ethylene Propylene BN = Buna-N Rubber KZ = Highly Fluorinated Fluorocarbon		SS = 316 Stainless Steel		Blank = Non-Keyed/Color Coded Brown = 1060 Black = 0045 Red = 2075 Orange = 3090 Yellow = 4105 Green = 5120

Example Part Number: IF-FS-251-V-SS-1060

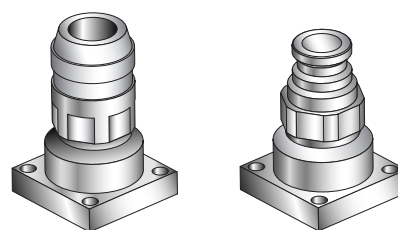

Female QC

Male QC

**FS SERIES Non-Spill Coupler**  
Reference Catalog 4220-USA

## Pressure Reducing Regulators

How to Order SMSQMICO Regulators

SMSQMICO	30	10	SS	RING
Port	Outlet Pressure Range	Flowpath	Material	Suffix
SMSQMICO	30 = 0-30 psig 60 = 0-60 psig HF30 = 0-30 psig HF60 = 0-60 psig 130E30 = 0-30 psig 130E60 = 0-60 psig	10	Blank = No Options SS = 316 Stainless Steel TH = Hastelloy C-22 Trim VESP = Vespel Seat	Ring

Example Part Number: SMSQMICO3010SSRING

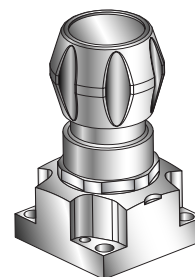

**SMAQMICO**  
**Pressure Reducing Regulators**  
Reference Catalog 25000143

# IntraFlow™

## Diaphragm Valves

How to Order SM930 Series Diaphragm Valves

SM930	LPNC	S	10	BK	RING
Port	Operator Type	Material	Flowpath	Optional Features	Suffix
SM930	<b>G</b> = Toggle <b>M</b> = Mini-Lever <b>LPNC</b> = Air Operated Normally Closed <b>LPNO</b> = Air Operated Normally Open	<b>S</b> = 316 Stainless Steel	<b>10</b>	<b>LK</b> = Lockout/Tagout (G Operator) <b>LOTO</b> = Lockout/Tagout (M Operator)	<b>RING</b>

Example Part Number: SM930LPNCS10BKRING

SM930  
Reference Catalog 25000146

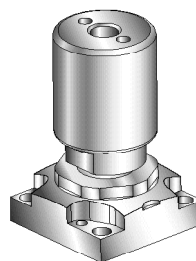

Diaphragm Actuated  
(54012129)

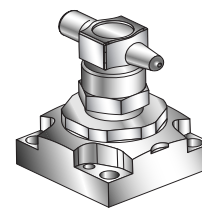

Diaphragm Manual  
(45700205)

## Functional Systems

Parker IntraFlow™ systems are easily standardized to provide common functionality for analyzer sample systems. Standardized functions simplify field maintenance for technicians with “plug & play” system changeout. Parker design engineers have developed numerous standardized systems that are available factory built and tested. Custom designs are also available as kitted components, or factory assembled and tested units. Consult with your local Authorized Parker Instrumentation Distributor or contact the factory for more details.

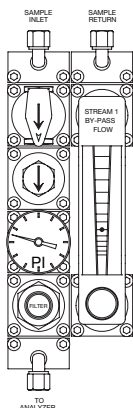

Basic Fast Loop System

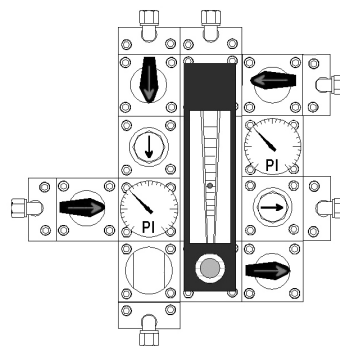
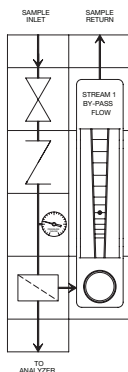

Enhanced Fast Loop System

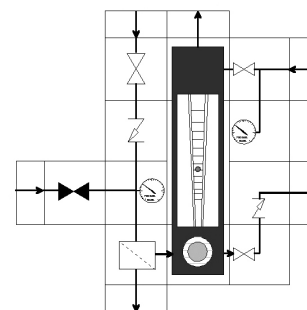

Sample Systems

# Intraflow™

## Enhanced Functionalities

New Vaporizing Regulator and SP76  
Compliant Volumetric Flow Controller



### Value Proposition:

Do you need to vaporize a liquid stream or accurately control low level flow rates?

Parker now offers an IntraFlow™ compatible vaporizing regulator system and volumetric flow controller that adds new functionalities to the IntraFlow™ ANSI/ISA SP76.00.02-2002 compliant modular system platform.

### Product Features:

- Close coupled vaporizing regulator with up to 500W power supply
- PID controlled heat source with external temperature sensor located adjacent to the regulator orifice
- Volumetric flow control maintains very stable conditions regardless of downstream pressure fluctuation
- Volumetric flow control vs. Mass Flow control

### Product Benefits:

- Higher energy capabilities in a small area enable efficient liquid vaporization
- More precise temperature control at optimal location
- Stabilizes continuous analyzer cell pressures
- No electrical hazardous area concerns

# IntraFlow™ : Enhanced Functionalities

## Vaporizing Regulators

The Parker Helical Vaporizer, DM4000 series regulator and Intertec Smart Blocktherm System combine to provide a vaporizing regulator solution for IntraFlow™ systems.

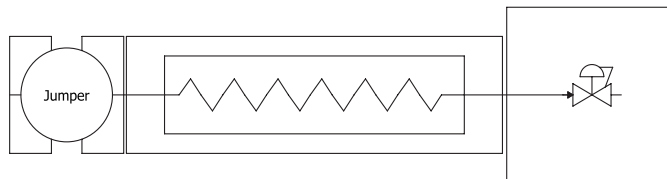

While the helical vaporizer and its holder are not specifically SP76 compliant devices, they seamlessly connect to SP76 components through the IntraFlow™ connector and substrate system. The vaporizing regulator consists of an inlet “jumper” (that allows for easy removal of the vaporizer for cleaning), the helical vaporizer block sub-assembly, the DM4000 regulator and a special 2.25” substrate. The Intertec heater mounts to the bottom of the IntraFlow™ pegboard and conductively heats the helical vaporizer as shown below. The heater is available with CSA Class 1, Division 1, Groups A,B,C,D as well as IEC Ex IIC T3/T4/T6 and IECEx PTB 08.0022X certifications for the heater block and PID Controller, respectively. Both versions offer optional 100, 200 and 500 watt heater capacities. Each Smart Blocktherm System includes an external temperature sensor that is optimally located within .039” (1mm) of the regulator’s inlet. The maximum temperature of the heater is managed electronically and an internal temperature sensitive fuse ensures that the maximum T-rating is never exceeded.

Computational Fluid Dynamic (CFD) analysis indicates that the system is capable of boiling water with a 25psig (1.72 barg) inlet pressure, a 5psig (.34 barg) outlet pressure and a heater set point of 274°F (190°C). The vaporization takes place between 75-85% of the length of the vaporizer sub-assembly.

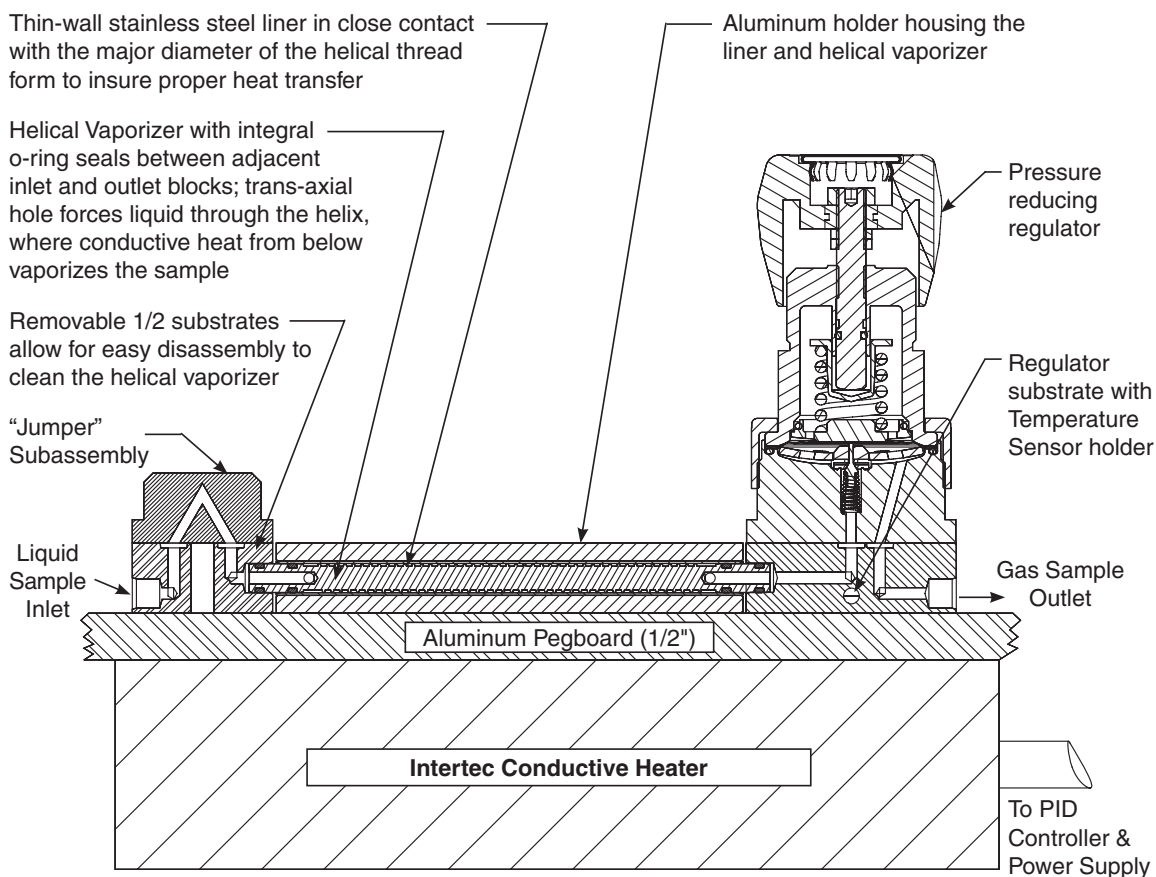

Sample Systems

# IntraFlow™: Enhanced Functionalities

## Vaporizing Regulators

Helical Vaporizer system components can be purchased individually, provided in a kit, or integrated into an assembled IntraFlow™ system. Individual component part numbers follow below:

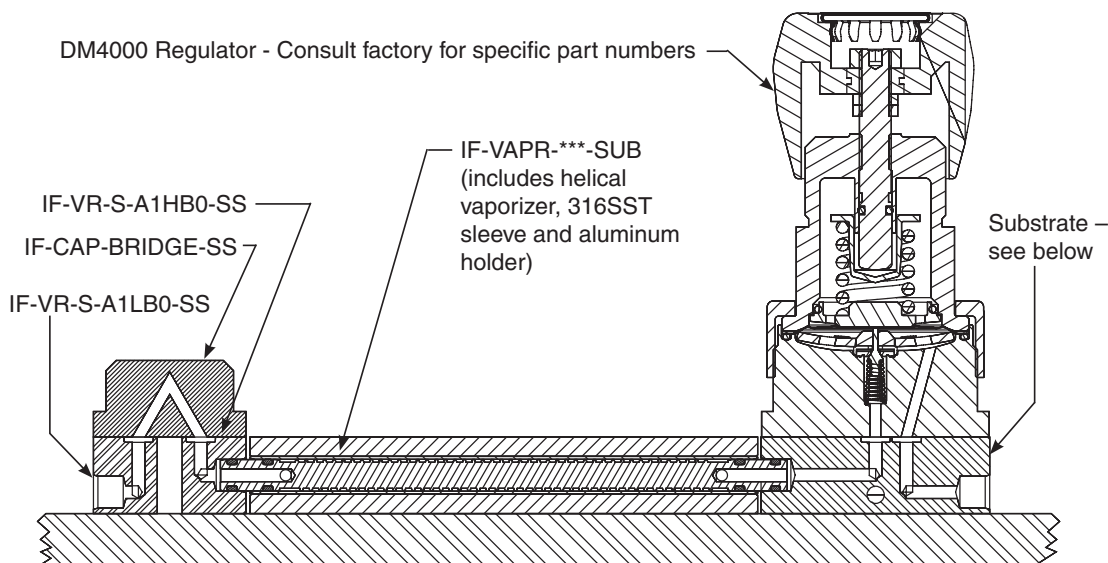

Intertec Temperature Sensor inserts here (2 location options for each substrate)

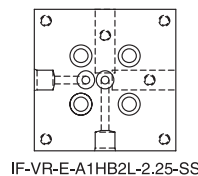
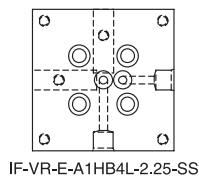
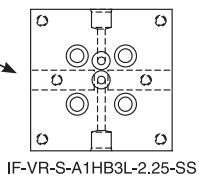

The helical vaporizer sub-assembly has non-standard centerlines. As such, the “jumper” 1/2 substrates have a standard IntraFlow™ inlet centerline and non-standard outlet centerline. Conversely, DM4000 regulator substrates have non-standard IntraFlow™ inlet centerlines and standard outlet centerlines. Regulator substrates also have 2 optional locations for the Intertec external temperature sensor, secured by a 10-32UNC set screw from the top of the substrate.

\*\*\* Character(s) indicate the elastomeric seal compound installed on the helical vaporizer. Specify the compound per the chart to the right.

When ordering a kitted set of components, specify part number KIT-IF-VAPR-\*\*\*-SS where the \*\*\* character(s) are replaced by the o-ring designators shown to the right. Kit includes everything listed in the drawing above with the exception of the regulator and substrate which must be configured and ordered separately.

### O-Ring Material

Seal Material	Seal Temperature Ratings
<b>BN:</b> Nitrile Rubber	-50°F to 300°F (-46°C to 149°C)
<b>EPR:</b> Ethylene Propylene Rubber	-50°F to 300°F (-46°C to 149°C)
<b>NE:</b> Neoprene Rubber	-50°F to 300°F (-46°C to 149°C)
<b>V:</b> Fluorocarbon Rubber	-25°F to 400°F (-32°C to 204°C)
<b>KZ:</b> Highly Fluorinated Fluorocarbon Rubber	-25°F to 200°F (-32°C to 93°C)

# IntraFlow™ : Enhanced Functionalities

## Vaporizer

The vaporizer assembly itself is a very efficient sample heater as a stand-alone sub-system. Following is a list of component part numbers required to for such an application. Note that the tube fitting adapter blocks are designed to accept 1/4" SAE straight thread tube fitting connectors with an o-ring seal. Connections are available out the end of the block or the top depending on tube-run orientations.

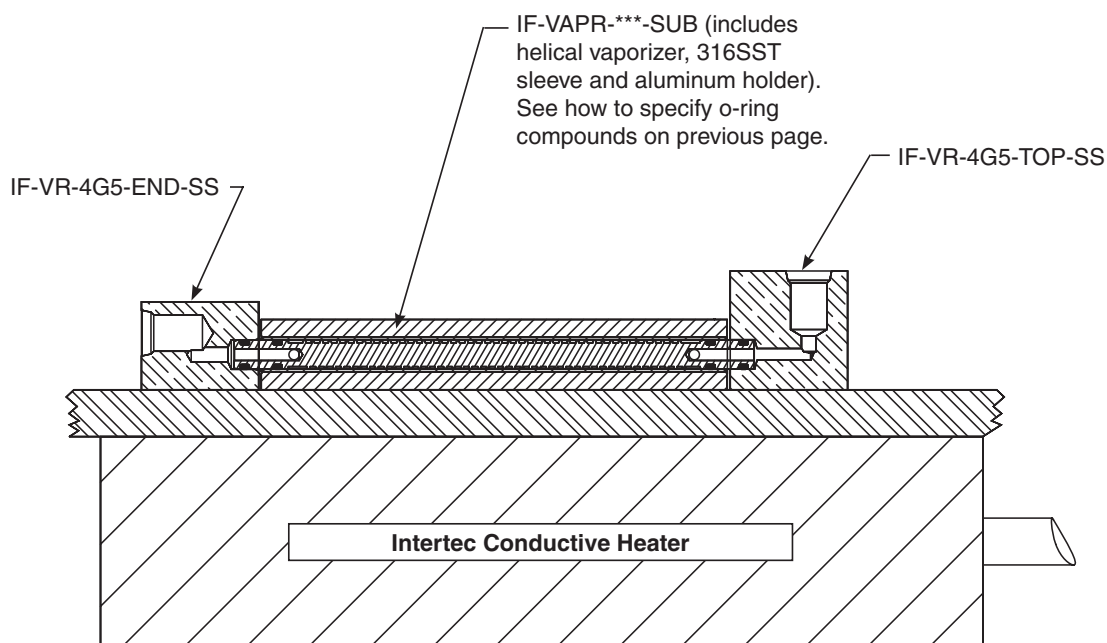
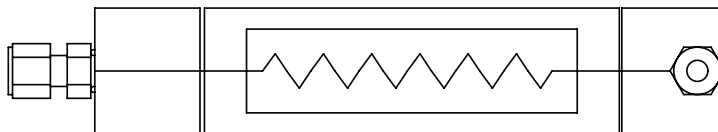

For more information on the CSA version, visit [www.intertec.info/common/pdf/cdn/HD127c.pdf](http://www.intertec.info/common/pdf/cdn/HD127c.pdf)

For more information on the ATEX version, visit [www.intertec.info/common/pdf/en/HD126e.pdf](http://www.intertec.info/common/pdf/en/HD126e.pdf)

Intertec products for IntraFlow applications can be supplied through Parker Distribution channels or Intertec Distribution Channels. To locate an Intertec Distributor, visit [www.intertec.info](http://www.intertec.info)

# IntraFlow™: Enhanced Functionalities

## Volumetric Flow Controller

The Parker VFC Flow Controller is precision engineered to control low gas flows at constant volumetric flow rates regardless of changes in downstream pressure. The VFC maintains a preset pressure differential across a metering valve. Setting the desired flow rate is accomplished by turning the fine-pitched adjusting stem, which varies the valve opening.

This design yields extremely linear flow output in relation to stem position. The metering valve is available with several different flow capacities ranging from 5sccm up to 3000sccm. The controlled differential can be adjusted from 2 to 5 psid (.137mbd to .344mbd) via a set screw on the side of the body with a 1/8" allen key. Optimal performance is with a differential pressure of 2psid (.137mbd).

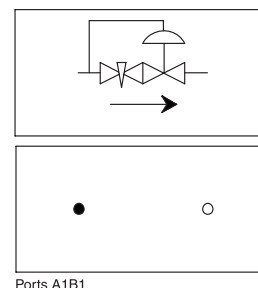

**Maximum Inlet Pressure:** 50psig (17.3 barg)  
 Temperature ratings based on o-ring compounds selected; see How to Order.

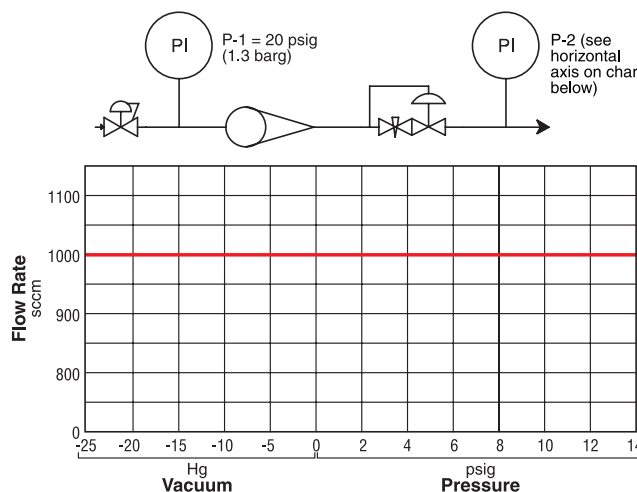
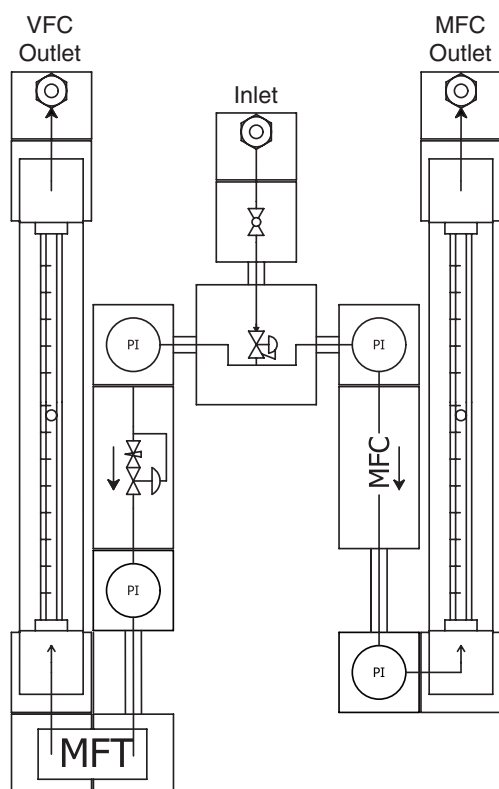

Comparison testing of the Volumetric Flow Controller (VFC) and a conventional Mass Flow Controller (MFC) indicate that each technology performs equally as well. When both sides of the system represented on the left are balanced with equal flow rates on each rotameter, the Mass Flow Transmitter downstream of the VFC has virtually the same output as the MFC. In the case of the VFC, the flow will remain at the setpoint if any back pressure develops downstream of the rotameter, as long as the inlet pressure is at least 2psig higher than the outlet pressure.

While both VFC (measured in volume per unit time) and MFC (measured in weight per unit time) technologies are proven measurement solutions, the VFC is a mechanical device that easily suits electrical hazardous area applications.

Sample Systems

# IntraFlow™ : Enhanced Functionalities

## Volumetric Flow Controllers

The VFC utilizes the HR series metering valve which is designed with a range 6 different lower stem tapers that dictate the maximum CV for each stem selection. The HR metering valve incorporates a special fine pitch thread with 15 turn resolution. To specify the correct HR valve stem for your VFC application, select the maximum CV control range from the flow curves below.

### C<sub>v</sub> vs. Turn Open

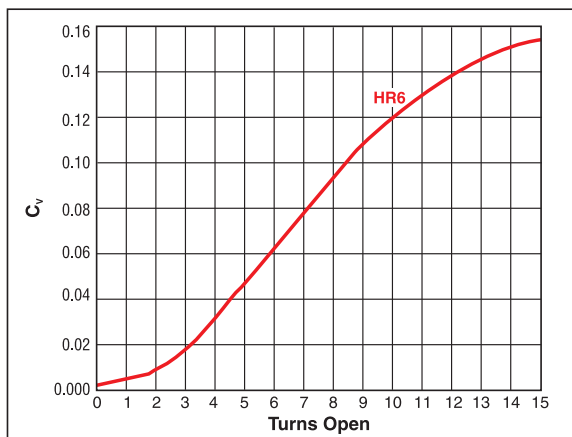
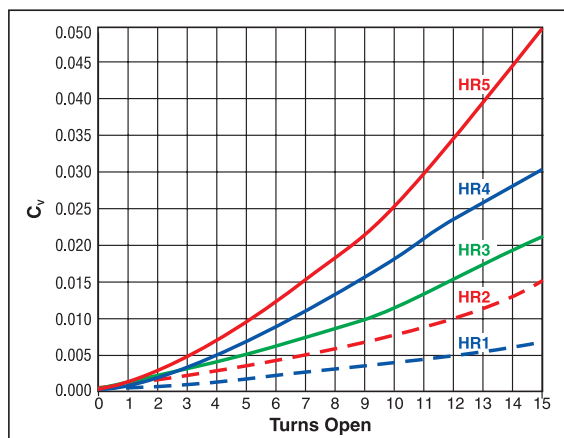
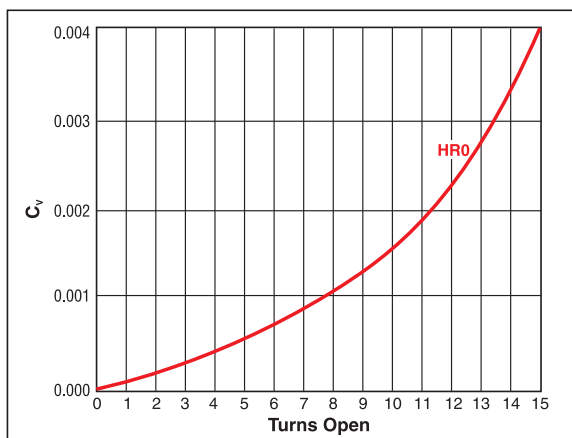

Sample Systems

# IntraFlow™: Enhanced Functionalities

## Volumetric Flow Controller: How to Order

Building a Part Number: *Example: IF-VFC-HR6-V-SS-K*

Example Part Number:	IF	–	VFC	–	HR	6	–	V	–	SS	–	K
Ordering Parameters/Options:	Prefix		Series		Valve Cartridge	Stem Taper		Seal Material	Seal Temperature Ratings	Body Material		Handle Type
Table Reference: (see below)	A		B		C	D		E	F	G		H

A - Prefix	
IF	IntraFlow

B - Series	
VFC	Volumetric Flow Controller

C - Valve Cartridge	
HR	HR Metering Valve

D - Stem Taper	
1	1 Taper - Orifice Size: 0.000083 in <sup>2</sup>
2	2 Taper - Orifice Size: 0.000168 in <sup>2</sup>
3	3 Taper - Orifice Size: 0.000241 in <sup>2</sup>
4	4 Taper - Orifice Size: 0.000674 in <sup>2</sup>
5	5 Taper - Orifice Size: 0.002325 in <sup>2</sup>
6	6 Taper - Orifice Size: 0.006227 in <sup>2</sup>

E - Seal Material		Seal Temperature Rating
BN	Nitrile Rubber	-50°F to 300°F (-46°C to 149°C)
EPR	Ethylene Propylene Rubber	-50°F to 300°F (-46°C to 149°C)
NE	Neoprene Rubber	-50°F to 300°F (-46°C to 149°C)
V	Fluorocarbon Rubber	25°F to 400°F (-32°C to 204°C)
KZ	Highly Fluorinated Fluorocarbon Rubber	-25°F to 200°F (-32°C to 93°C)

F - Body Material	
SS	316 Stainless Steel

G - Valve Cartridge	
K	Knurled
TC	Knurled With Slot
NS	No Handle (Slotted Stem)

# Appendix

Schematic: NEED TITLE DESCRIPTION

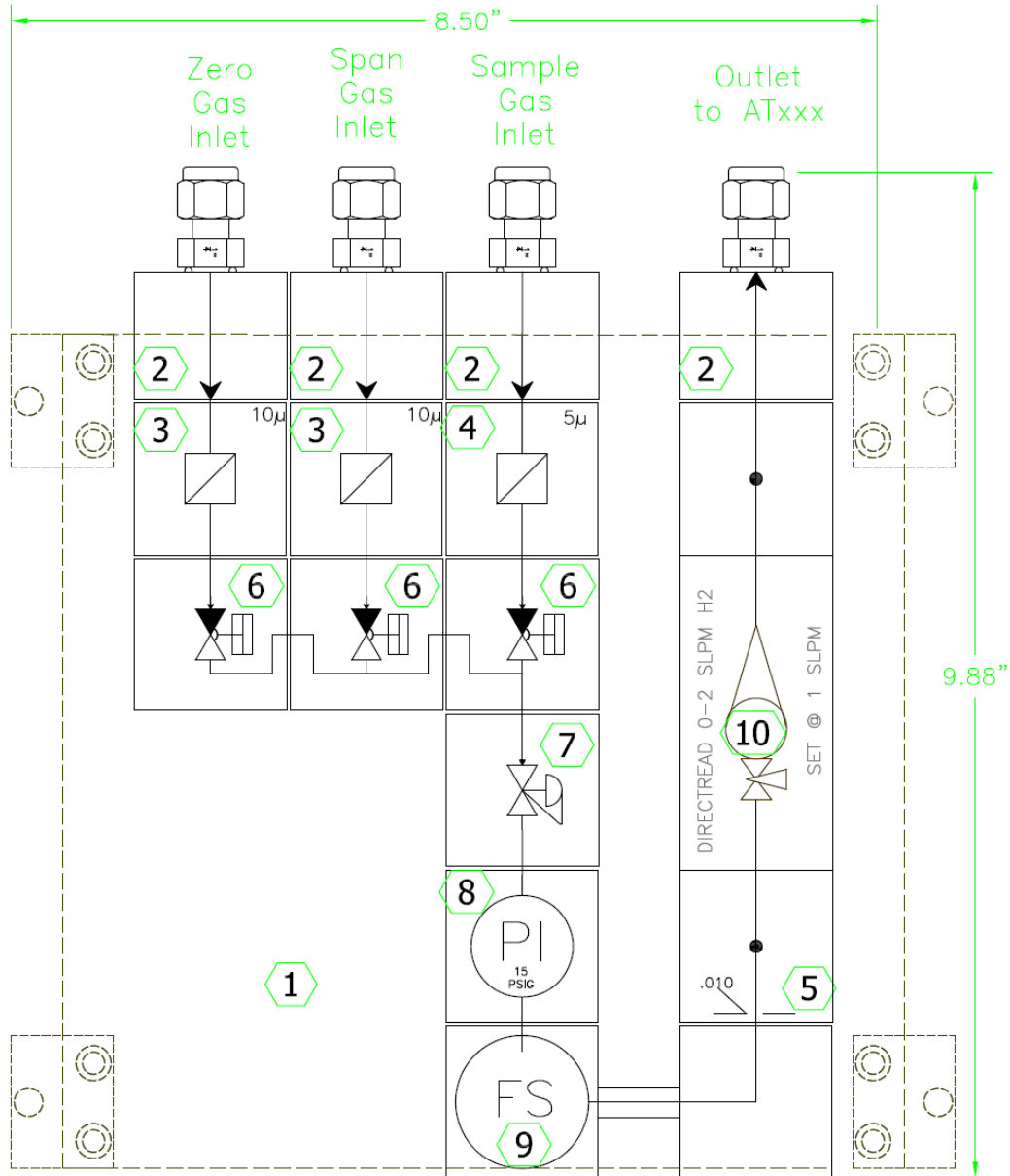

Parts List					
ITEM	QTY	NAME	ITEM	QTY	NAME
1	1	IF-PEGBOARD-11X11-SS	5	1	SS-2-VCR-2-250-ID
2	4	4-4 ZHBA-SS	6	3	DM930LPNCS10
3	2	IF-FT4-10-SS	7	1	DM3001S10
4	1	IF-FT4-5-SS	8	1	GAUGE-50025228
			9	1	FS10A-2A403E002
			10	1	P430A4113810-IFS060-001

# Appendix

Schematic: NEED TITLE DESCRIPTION

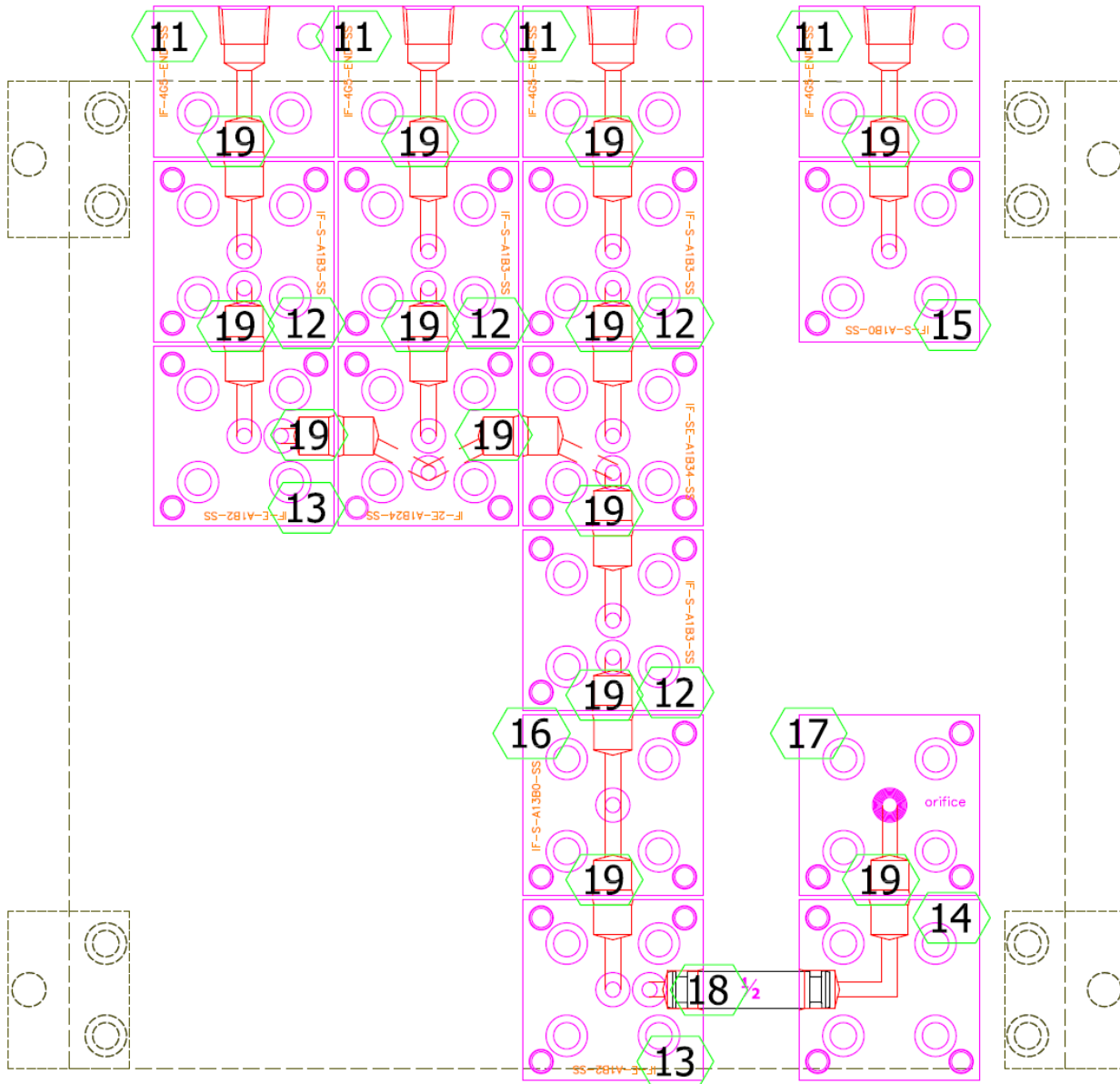

# Appendix

## Schematic: NEED TITLE DESCRIPTION

ITEM	QTY	NAME	DESCRIPTION
1	1	IF-PEGBOARD-12X21-SS	STAINLESS STEEL PEGBOARD
2	4	IF-2F-END-SS	1/8" FIELD CONNECTOR-END ACCESS
3	5	IF-2F-TOP-SS	1/8" FNPT FIELD CONNECTION TOP ACCESS
4	3	IF-MB2LPPA-KZ-SS	MB SERIES 2-WAY BALL VALVE, KZ
5	3	IF-RD3K-KZ-SS	GEN II DBR R-MAX
6	1	IF-H6L-KZ-SS-K	METERING VALVE
7	2	IF-R3K-KZ-SS	GEN II R-MAX SINGLE
8	1	IF-CD4L-1/3-KZ-SS	CHECK VALVE, 1/3 PSIG CRACK
9	3	GAUGE-9118101	0-60 PSIG GAUGE w/ BASE
10	1	IF-F14-S-KZ-SS	INLINE FILTER, 5µ, KZ
11	1	VG464410K800000000000003	24-240 CC/min DK32 w/o valve
12	1	DM-2000 SERIES	Flow Pressure & Temp. Sensor (Provided By Others)

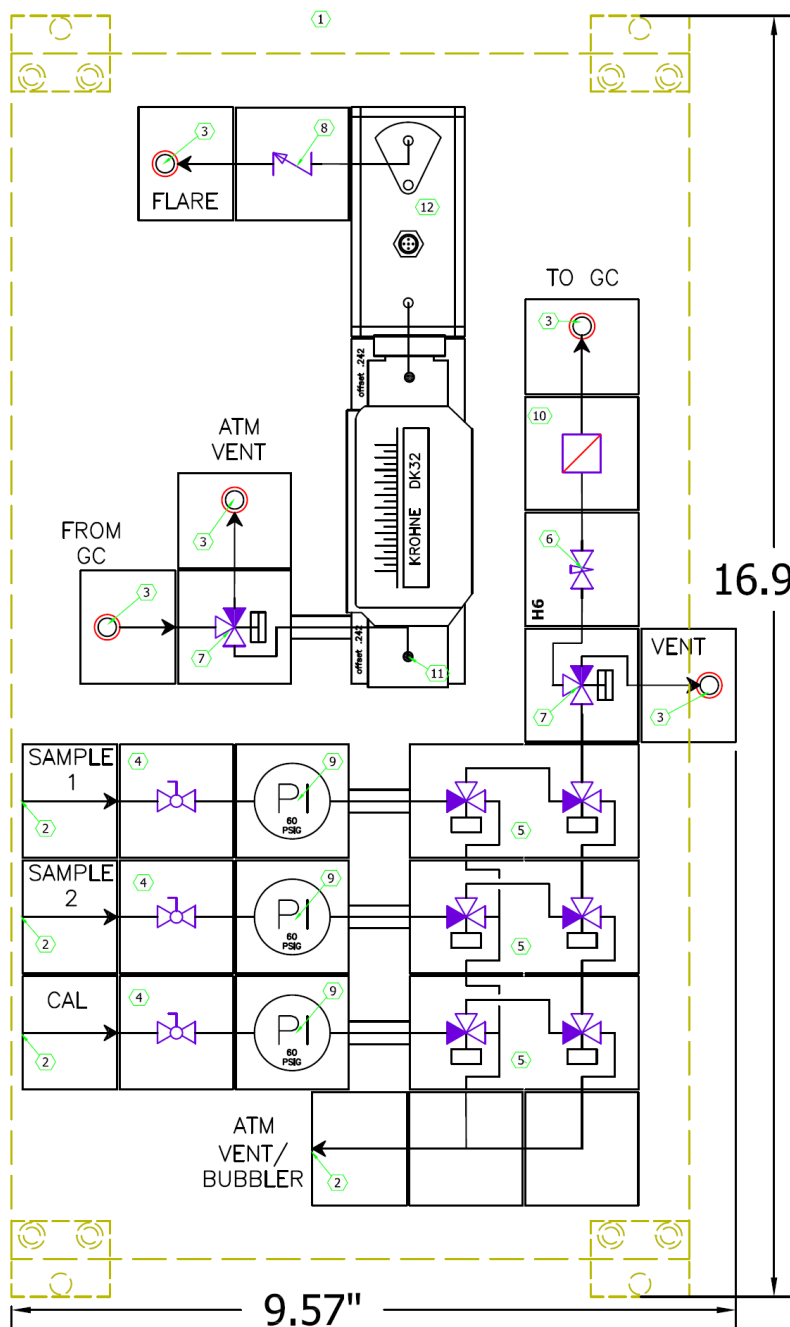

# Appendix

Schematic: NEED TITLE DESCRIPTION

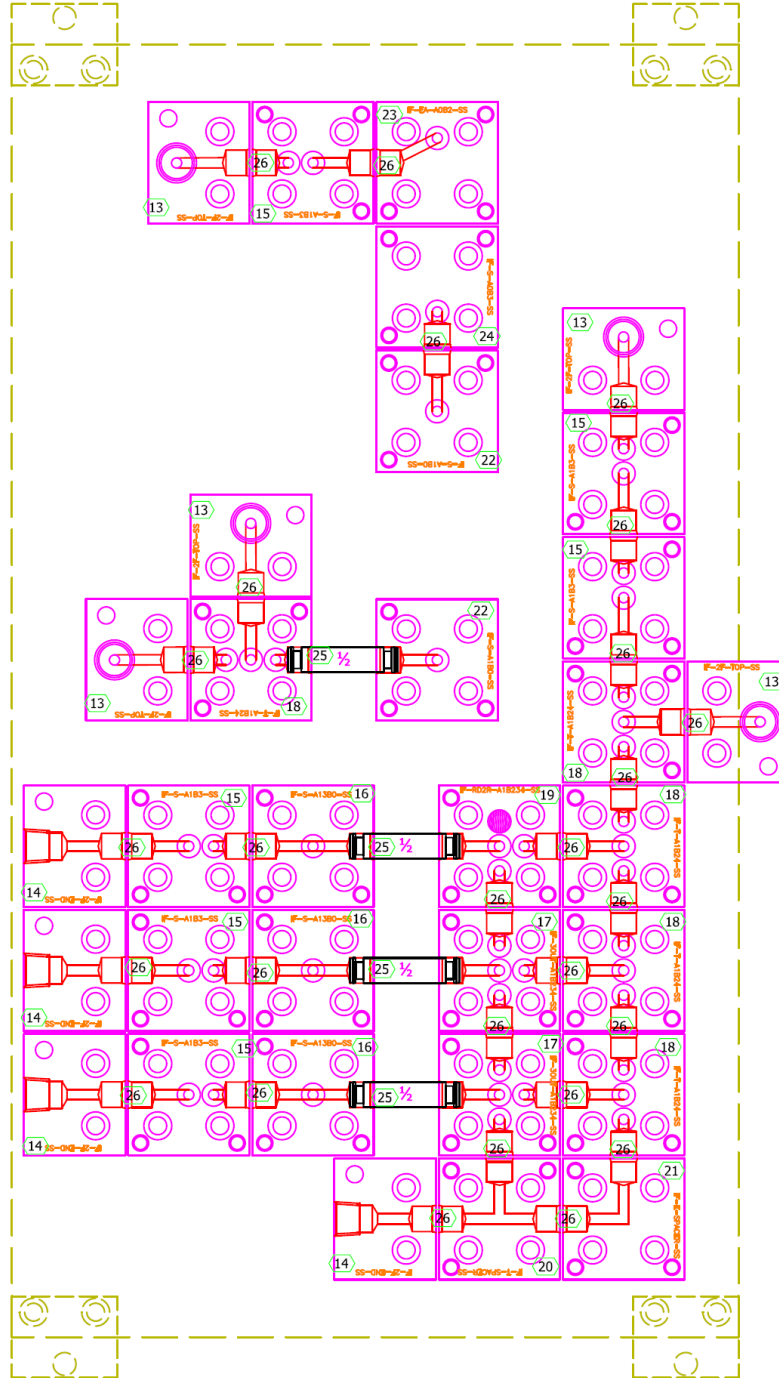

# Appendix

## Schematic: NEED TITLE DESCRIPTION

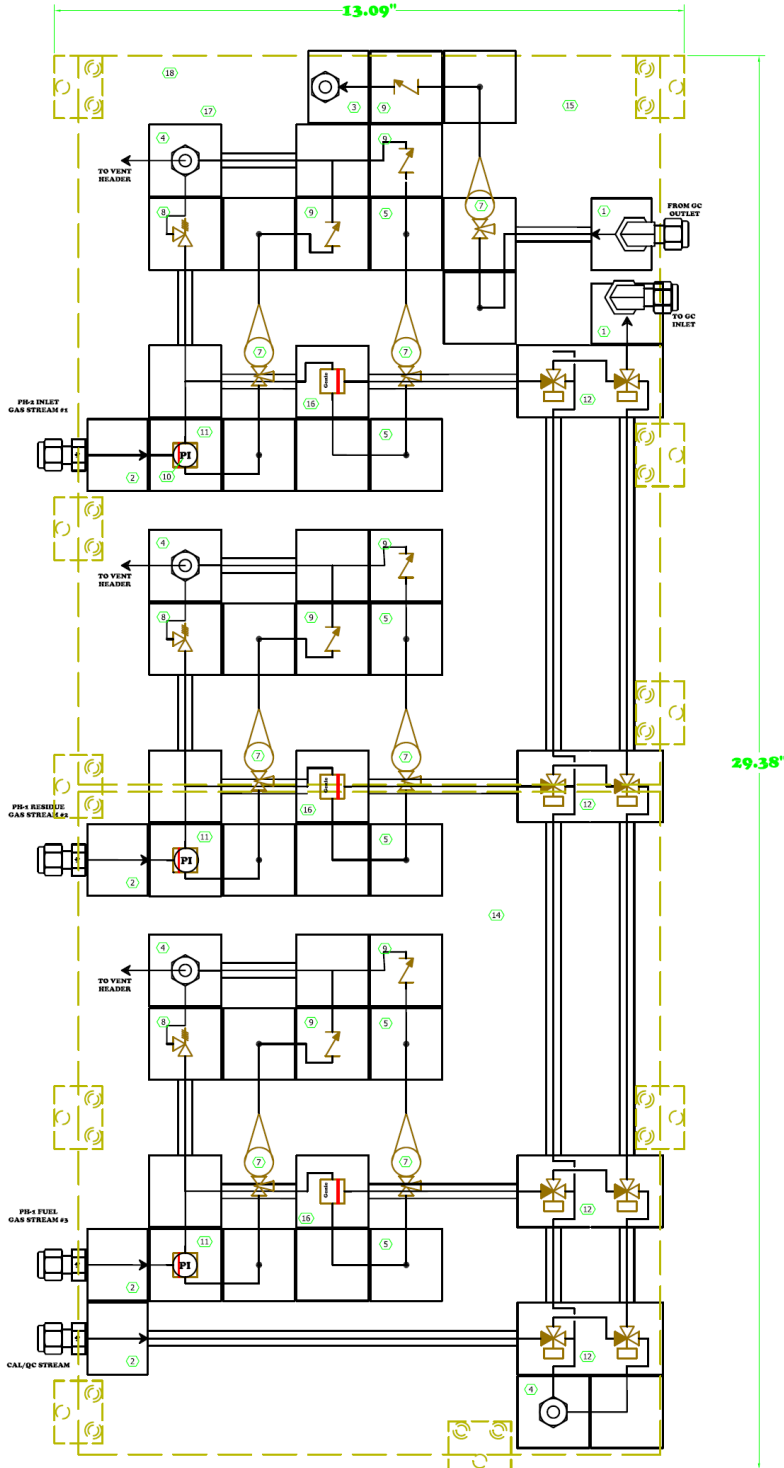

Parts List			
ITEM	QTY	NAME	DESCRIPTION
1	3	4-4 CSBZ-SS-C	TOP ACCESS FIELD CONNETION WITH 1/4" A-LOK FITTINGS
2	4	4-4 ZHBA-SS-C	END ACCESS FIELD CONNETION WITH 1/4" A-LOK FITTINGS
3	1	4-4 ZHBA-SS-C	TOP ACCESS FIELD CONNETION WITH 1/4" A-LOK FITTINGS
4	4	IF-4Z(A)-BASE-2P-SS	1/4" COMPRESSION BASE w/A-LOK
5	14	IF-4TA-OFFSET-1P-SS	ROTAMETER OFFSET ADAPTER
7	7	IF-F65SB1V-A-125-5-SAPP	GLASS TUBE ROTAMETER, INLET VALVE, VITON, 0-120 cc/min
8	3	IF-RL4A-VT-2P-SS-KA	RELIEF VALVE, VITON, 10-25 PSI CRACK
9	7	IF-CO4L-1/3-V-SS	CHECK VALVE, 1/3 PSIG CRACK, VITON
10	3	GAUGE-50025228	0-15 PSIG FILTER MOUNTED
11	3	IF-FR3-V-C93-SS	COALESCING BYPASS FILTER, VITON
12	4	IF-RD3K-V-SS-FF	GEN II DBB R-MAX
14	1	IF-PEGBOARD-16X18-SS	1/8" SS PEGBOARD
15	1	IF-PEGBOARD-16X20-SS	1/8" SS PEGBOARD
16	3	MG-3406	GENIE MEMBRANE SEPARATOR w/ TYPE S MEMBRANE (BTU)
17	5	MG-SXS	SPAIR MEMBRANE KIT TYPE S
18	1	FR2-ELEMENT-CL93	COALACING FILTER ELEMENT KIT (qty.10)

# Appendix

## Schematic: NEED TITLE DESCRIPTION

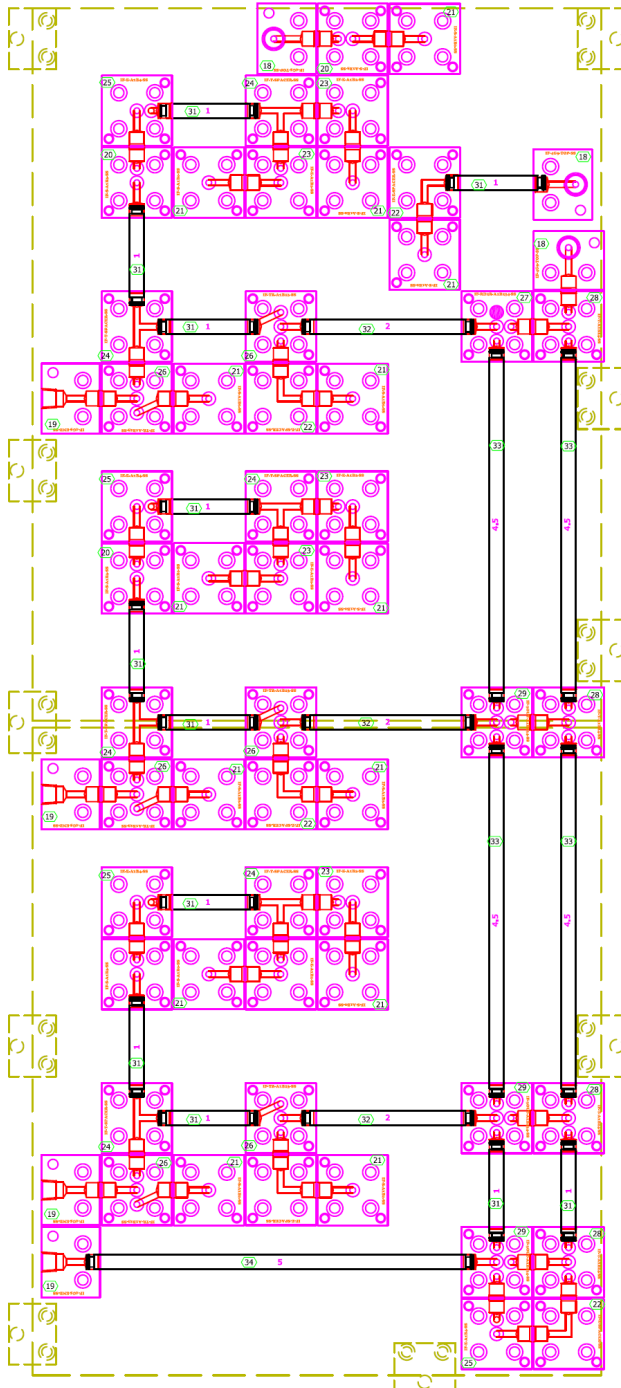

Substrate Level Parts List			
ITEM	QTY	NAME	DESCRIPTION
16	7	O-RING 3-904 V1226-75	O-RING FOR FITTING, VITON
17	88	O-RING 2-007 V1226-75	O-RING FOR TOP OF SUBSTRATES, VITON
18	3	IF-4GS-TOP-SS	FIELD CONNECTION
19	4	IF-4GS-END-SS	FIELD CONNECTION
20	4	IF-S-A1B3-SS	2 PORT
21	14	IF-S-A1B0-SS	1 PORT
22	5	IF-E-SPACER-SS	ELBOW
23	6	IF-E-A1B2-SS	2 PORT
24	6	IF-T-SPACER-SS	TEE
25	4	IF-E-A1B4-SS	2 PORT
26	6	IF-TR-A1B23-SS	3 PORT
27	1	IF-RD2R-A1B234-SS	4 PORT W/1 CAPPED
28	4	IF-T-A1B24-SS	3 PORT
29	3	IF-3OUT-A1B234-SS	4 PORT
30	41	IF-CONNECTOR-V-SS	CONNECTOR, VITON
31	12	IF-CONNECTOR-1-V-SS	CONNECTOR 1, VITON
32	3	IF-CONNECTOR-2-V-SS	CONNECTOR 2, VITON
33	4	IF-CONNECTOR-4.5-V-SS	CONNECTOR 4.5, VITON
34	1	IF-CONNECTOR-5-V-SS	CONNECTOR 5, VITON

# Appendix

## Schematic: NEED TITLE DESCRIPTION

Top Level Parts List							
ITEM	QTY	NAME	DESCRIPTION	ITEM	QTY	NAME	DESCRIPTION
1	1	IF-PEGBOARD-20X20-AL	1/2" SS PEGBOARD	9	1	IF-RD3K-KZ-SS-FF (DIVERTER)	GEN II DBB R-MAX, KZ (USED AS DIVERTER MODULE)
2	4	IF-SUPPORT-TOP-SS	TOP PEGBOARD MOUNT	10	1	7101461007A	0-11.3 SLPM, KZ, INLET VALVE
3	4	IF-SUPPORT-PGBRD-SS	BOTTOM SS PEGBOARD MOUNT	11	1	7101461005A	0-6 SLPM, KZ, INLET VALVE
4	8	4-4 ZHBA-SS-C	TOP ACCESS FIELD CONNECTION WITH 1/4" COMPRESSION FITTING	12	1	FS10A-7C4F4E001	FLOW TRANSMITTER, Class I Div. 1, W/REMOTE MOUNTED SENSOR
6	3	IF-HNV-SS	NEEDLE VALVE	13	1	HDX3-P-0035	CP BLOCKTHERM CPA T3 HI 120V 200W, C1D1
7	1	IF-FT4-S-KZ-SS	INLINE FILTER, 5µ, KZ	14	1	HFCl-6C-0059	TEMP. CONTROLLER CSA, TC C D E1 S J, C1D1
8	3	IF-RD3K-KZ-SS-FF	GEN II DBB R-MAX, KZ				

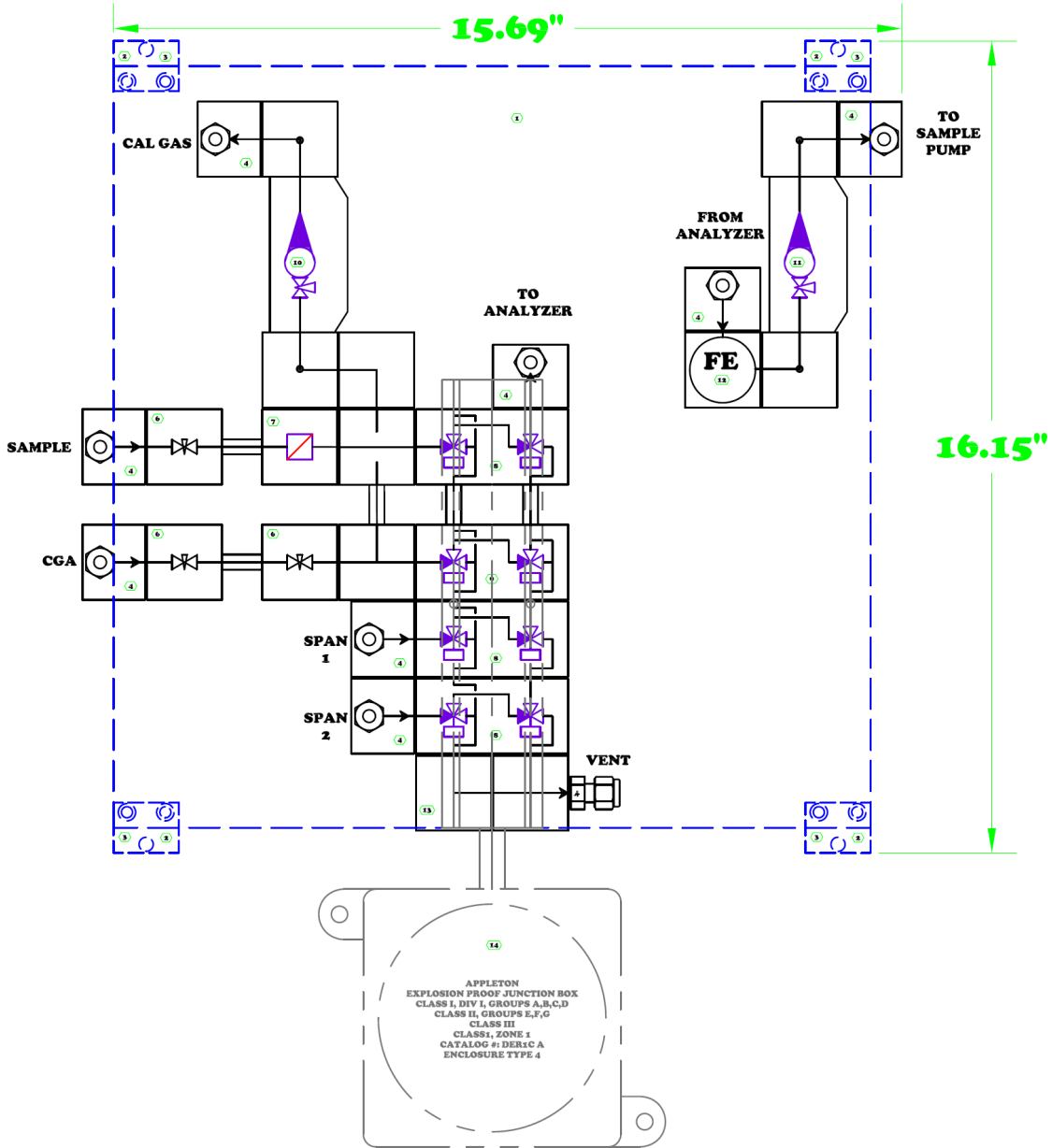

# Appendix

Substrate Parts List					
ITEM	QTY	NAME	ITEM	QTY	NAME
15	8	IF-4G5-TOP-SS	22	1	IF-JUMPER-SS
16	4	IF-S-A1B3-SS	23	3	IF-3OUT-A1B234-SS
17	4	IF-S-A1B0-SS	24	3	IF-T-A1B24-SS
18	1	IF-E-A1B2-SS	25	1	IF-RD2R-A1B234-SS
19	2	IF-E-SPACER-SS	26	1	IF-TOV-A1B24-SS
20	1	IF-4G5-END-ER-SPACER-SS	27	5	IF-CONNECTOR-1/2-KZ-SS
21	1	IF-T-SPACER-SS	28	26	IF-CONNECTOR-KZ-SS

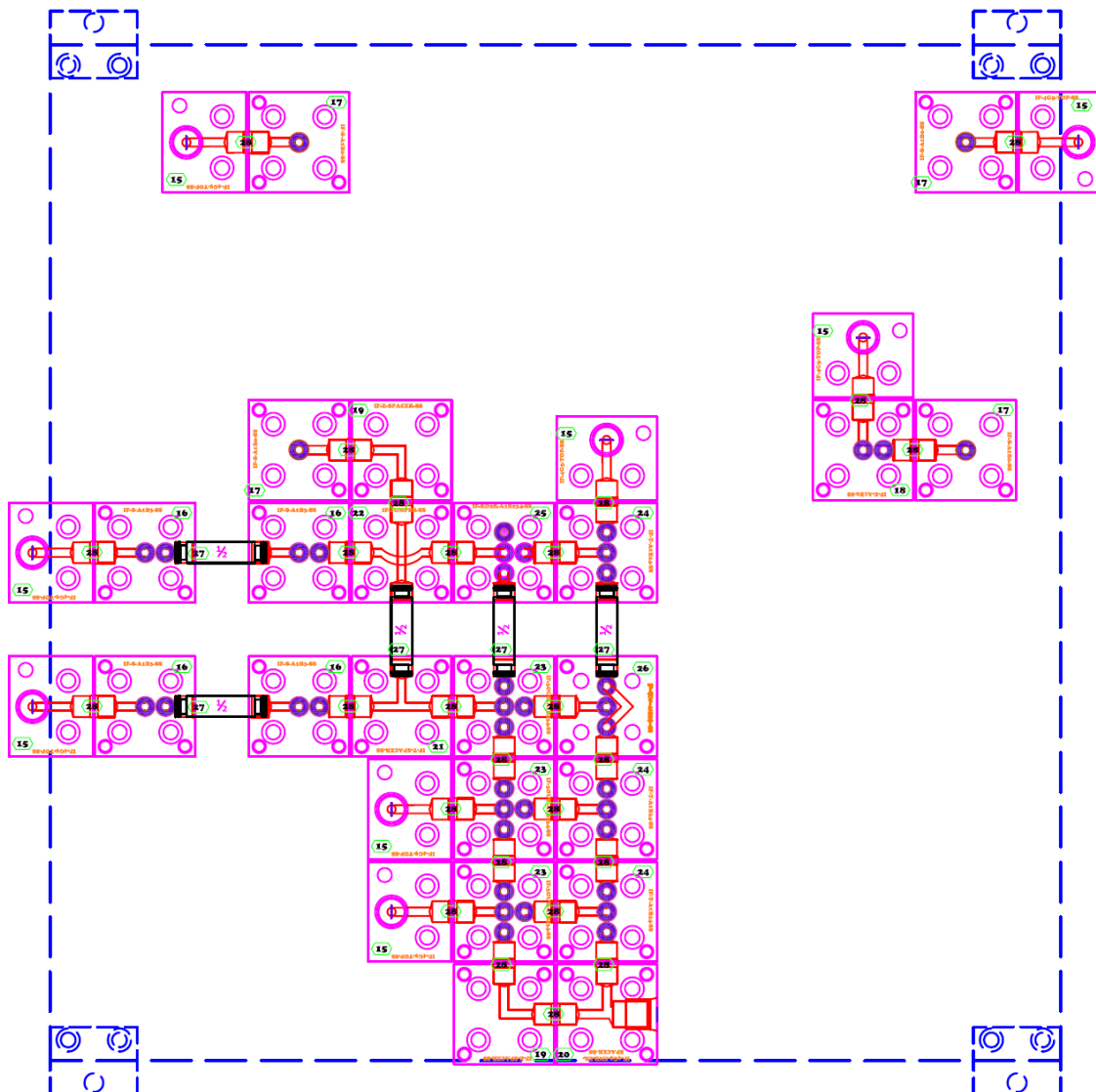

# Appendix

## Conversions:

Pressure Conversion Table: (Units used in this manual)													
Units	psi	kPa	kg/cm2	cm of H2O	feet of H2O	inches of Hg	mm of HG	inches of H2O	ounces per sq. inch	Atm (atmospheres)	bar	mbar	Mpa
psi	1	6.89476	0.07031	70.3069	2.30672	2.03602	51.7149	27.6807	16	0.068046	0.6895	68.9476	0.00689
kPa	0.14504	1	0.0102	10.1975	0.33456	0.2953	7.50061	4.01472	2.3206	0.00966924	0.01	10	0.001
kg/cm2	14.2233	98.0669	1	1000.03	32.8093	28.959	735.559	393	227.573	0.9678416	0.98066	1013.25	0.09806
cm of H2O	0.01422	0.09806	0.001	1	0.03281	0.02896	0.73554	0.3937	0.22757	0.00096781	0.0098	0.9806	0.00098
feet of H2O	0.43352	2.96896	0.03048	30.48	1	0.88265	22.4192	12	6.93624	0.2949896	0.02969	29.689	0.00298
inches of Hg	0.49115	3.386389	0.03453	34.5325	1.13296	1	25.4	13.5955	7.85847	0.0334211	0.03386	33.8639	0.00386
mm of Hg	0.01934	0.13332	0.00136	1.35955	0.0446	0.03937	1	0.53526	0.30939	0.00131579	0.00133	1.33322	0.00013
inches of H2O	0.03613	0.24908	0.00254	2.54	0.0333	0.07355	1.86827	1	0.57802	0.00245825	0.00249	2.49089	0.00025
ounces per sq. inch	0.0625	0.43092	0.00439	4.39431	0.14417	0.12725	3.23218	1.73004	1	0.00425288	0.00431	4.309	0.00043
Atm (atmospheres)	14.696	101.325	1.03323	1033.26	33.8995	29.9213	760	406.794	235.136	1	1.01325	1013.25	0.1013
bar	14.5038	100	1.01972	1019.75	33.4833	29.53	750.063	401.86	232.064	0.986923	1	1000	0.1
mbar	0.0145	0.1	300102	1.019	0.00346	0.02953	0.75006	0.40146	0.23206	0.00099	0.001	1	0.0001
Mpa	145.038	1000	10.197	10197.5	334.56	295.299	7500.61	4014.74	2320.6	9.669	10	10000	1

Volume Conversion Table: (Units used in this manual)						
Units	Liters	cc (cubic centimeters)	ml (milliliters)	ft³ (cubic feet)	Inch³ (cubic inches)	Gallon
Liters	1	1000	1000	0.03531467	61.02374	0.2641721
cc (cubic centimeters)	1000	1	1	3.53147-5	0.06102374	0.000264172
ml (milliliters)	1000	1	1	3.53147-5	0.06102374	0.000264172
ft³ (cubic feet)	28.31685	28,316.85	28,316.85	1	1,728.00	7.480519
Inch³ (cubic inches)	0.01638706	16.38706	16.38706	0.000578704	1	0.004329004
Gallon	3.785412	3,785.41	3,785.41	0.1336806	231	1



# Offer of Sale

The items described in this document and other documents and descriptions provided by Parker Hannifin Corporation, its subsidiaries and its authorized distributors ("Seller") are hereby offered for sale at prices to be established by Seller. This offer and its acceptance by any customer ("Buyer") shall be governed by all of the following Terms and Conditions. Buyer's order for any item described in its document, when communicated to Seller verbally, or in writing, shall constitute acceptance of this offer. All goods or work described will be referred to as "Products".

1. **Terms and Conditions.** Seller's willingness to offer Products, or accept an order for Products, to or from Buyer is expressly conditioned on Buyer's assent to these Terms and Conditions and to the terms and conditions found on-line at [www.parker.com/salesterms/](http://www.parker.com/salesterms/). Seller objects to any contrary or additional term or condition of Buyer's order or any other document issued by Buyer.

2. **Price Adjustments; Payments.** Prices stated on the reverse side or preceding pages of this document are valid for 30 days. After 30 days, Seller may change prices to reflect any increase in its costs resulting from state, federal or local legislation, price increases from its suppliers, or any change in the rate, charge, or classification of any carrier. The prices stated on the reverse or preceding pages of this document do not include any sales, use, or other taxes unless so stated specifically. Unless otherwise specified by Seller, all prices are F.O.B. Seller's facility, and payment is due 30 days from the date of invoice. After 30 days, Buyer shall pay interest on any unpaid invoices at the rate of 1.5% per month or the maximum allowable rate under applicable law.

3. **Delivery Dates; Title and Risk; Shipment.** All delivery dates are approximate and Seller shall not be responsible for any damages resulting from any delay. Regardless of the manner of shipment, title to any products and risk of loss or damage shall pass to Buyer upon tender to the carrier at Seller's facility (i.e., when it's on the truck, it's yours). Unless otherwise stated, Seller may exercise its judgment in choosing the carrier and means of delivery. No deferral of shipment at Buyers' request beyond the respective dates indicated will be made except on terms that will indemnify, defend and hold Seller harmless against all loss and additional expense. Buyer shall be responsible for any additional shipping charges incurred by Seller due to Buyer's changes in shipping, product specifications or in accordance with Section 13, herein.

4. **Warranty.** Seller warrants that the Products sold here-under shall be free from defects in material or workmanship for a period of twelve months from the date of delivery to Buyer or 2,000 hours of normal use, whichever occurs first. This warranty is made only to Buyer and does not extend to anyone to whom Products are sold after purchased from Seller. The prices charged for Seller's products are based upon the exclusive limited warranty stated above, and upon the following disclaimer: **DISCLAIMER OF WARRANTY: THIS WARRANTY COMPRISES THE SOLE AND ENTIRE WARRANTY PERTAINING TO PRODUCTS PROVIDED HEREUNDER. SELLER DISCLAIMS ALL OTHER WARRANTIES, EXPRESS AND IMPLIED, INCLUDING MERCHANTABILITY AND FITNESS FOR A PARTICULAR PURPOSE.**

5. **Claims; Commencement of Actions.** Buyer shall promptly inspect all Products upon delivery. No claims for shortages will be allowed unless reported to the Seller within 10 days of delivery. No other claims against Seller will be allowed unless asserted in writing within 60 days after delivery or, in the case of an alleged breach of warranty, within 30 days after the date within the warranty period on which the defect is or should have been discovered by Buyer. Any action based upon breach of this agreement or upon any other claim arising out of this sale (other than an action by Seller for any amount due to Seller from Buyer) must be commenced within thirteen months from the date of tender of delivery by Seller or, for a cause of action based upon an alleged breach of warranty, within thirteen months from the date within the warranty period on which the defect is or should have been discovered by Buyer.

6. **LIMITATION OF LIABILITY. UPON NOTIFICATION, SELLER WILL, AT ITS OPTION, REPAIR OR REPLACE A DEFECTIVE PRODUCT, OR REFUND THE PURCHASE PRICE. IN NO EVENT SHALL SELLER BE LIABLE TO BUYER FOR ANY SPECIAL, INDIRECT, INCIDENTAL OR CONSEQUENTIAL DAMAGES ARISING OUT OF, OR AS THE RESULT OF, THE SALE, DELIVERY, NON-DELIVERY, SERVICING, USE OR LOSS OF USE OF THE PRODUCTS OR ANY PART THEREOF, OR FOR ANY CHARGES OR EXPENSES OF ANY NATURE INCURRED WITHOUT SELLER'S WRITTEN CONSENT, EVEN IF SELLER HAS BEEN NEGLIGENT, WHETHER IN CONTRACT, TORT OR OTHER LEGAL THEORY. IN NO EVENT SHALL SELLER'S LIABILITY UNDER ANY CLAIM MADE BY BUYER EXCEED THE PURCHASE PRICE OF THE PRODUCTS.**

7. **Contingencies.** Seller shall not be liable for any default or delay in performance if caused by circumstances beyond the reasonable control of Seller.

8. **User Responsibility.** The user, through its own analysis and testing, is solely responsible for making the final selection of the system and Product and assuring that all performance, endurance, maintenance, safety and warning requirements of the application are met. The user must analyze all aspects of the application and follow applicable industry standards and Product information. If Seller provides Product or system options, the user is responsible for determining that such data and specifications are suitable and sufficient for all applications and reasonably foreseeable uses of the Products or systems.

9. **Loss to Buyer's Property.** Any designs, tools, patterns, materials, drawings, confidential information or equipment furnished by Buyer or any other items which become Buyer's property, may be considered obsolete and may be destroyed by Seller after two consecutive years have elapsed without Buyer placing an order for the items which are manufactured using such property. Seller shall not be responsible for any loss or damage to such property while it is in Seller's possession or control.

10. **Special Tooling.** A tooling charge may be imposed for any special tooling, including without limitation, dies, fixtures, molds and patterns, acquired to manufacture Products. Such special tooling shall be and remain Seller's property notwithstanding payment of any charges by Buyer. In no event will Buyer acquire any interest in apparatus belonging to Seller which is utilized in the manufacture of the Products, even if such apparatus has been specially converted or adapted for such manufacture and notwithstanding any charges paid by Buyer. Unless otherwise agreed, Seller shall have the right to alter, discard or otherwise dispose of any special tooling or other property in its sole discretion at any time.

11. **Buyer's Obligation; Rights of Seller.** To secure payment of all sums due or otherwise, Seller shall retain a security interest in the goods delivered and this agreement shall be deemed a Security Agreement under the Uniform Commercial Code. Buyer authorizes Seller as its attorney to execute and file on Buyer's behalf all documents Seller deems necessary to perfect its security interest. Seller shall have a security interest in, and lien upon, any property of Buyer in Seller's possession as security for the payment of any amounts owed to Seller by Buyer.

12. **Improper use and Indemnity.** Buyer shall indemnify, defend, and hold Seller harmless from any claim, liability, damages, lawsuits, and costs (including attorney fees), whether for personal injury, property damage, patent, trademark or copyright infringement or any other claim, brought by or incurred by Buyer, Buyer's employees, or any other person, arising out of: (a) improper selection, improper application or other misuse of Products purchased by Buyer from Seller; (b) any act or omission, negligent or otherwise, of Buyer; (c) Seller's use of patterns, plans, drawings, or specifications furnished by Buyer to manufacture Product; or (d) Buyer's failure to comply with these terms and conditions. Seller shall not indemnify Buyer under any circumstance except as otherwise provided.

13. **Cancellations and Changes.** Orders shall not be subject to cancellation or change by Buyer for any reason, except with Seller's written consent and upon terms that will indemnify, defend and hold Seller harmless against all direct, incidental and consequential loss or damage. Seller may change product features, specifications, designs and availability with notice to Buyer.

14. **Limitation on Assignment.** Buyer may not assign its rights or obligations under this agreement without the prior written consent of Seller.

15. **Entire Agreement.** This agreement contains the entire agreement between the Buyer and Seller and constitutes the final, complete and exclusive expression of the terms of the agreement. All prior or contemporaneous written or oral agreements or negotiations with respect to the subject matter are herein merged.

16. **Waiver and Severability.** Failure to enforce any provision of this agreement will not waive that provision nor will any such failure prejudice Seller's right to enforce that provision in the future. Invalidation of any provision of this agreement by legislation or other rule of law shall not invalidate any other provision herein. The remaining provisions of this agreement will remain in full force and effect.

17. **Termination.** This agreement may be terminated by Seller for any reason and at any time by giving Buyer thirty (30) days written notice of termination. In addition, Seller may by written notice immediately terminate this agreement for the following: (a) Buyer commits a breach of any provision of this agreement (b) the appointment of a trustee, receiver or custodian for all or any part of Buyer's property (c) the filing of a petition for relief in bankruptcy of the other Party on its own behalf, or by a third party (d) an assignment for the benefit of creditors, or (e) the dissolution or liquidation of the Buyer.

18. **Governing Law.** This agreement and the sale and delivery of all Products hereunder shall be deemed to have taken place in and shall be governed and construed in accordance with the laws of the State of Ohio, as applicable to contracts executed and wholly performed therein and without regard to conflicts of laws principles. Buyer irrevocably agrees and consents to the exclusive jurisdiction and venue of the courts of Cuyahoga County, Ohio with respect to any dispute, controversy or claim arising out of or relating to this agreement. Disputes between the parties shall not be settled by arbitration unless, after a dispute has arisen, both parties expressly agree in writing to arbitrate the dispute.

19. **Indemnity for Infringement of Intellectual Property Rights.** Seller shall have no liability for infringement of any patents, trademarks, copyrights, trade dress, trade secrets or similar rights except as provided in this Section. Seller will defend and indemnify Buyer against allegations of infringement of U.S. patents, U.S. trademarks, copyrights, trade dress and trade secrets ("Intellectual Property Rights"). Seller will defend at its expense and will pay the cost of any settlement or damages awarded in an action brought against Buyer based on an allegation that a Product sold pursuant to this Agreement infringes the Intellectual Property Rights of a third party. Seller's obligation to defend and indemnify Buyer is contingent on Buyer notifying Seller within ten (10) days after Buyer becomes aware of such allegations of infringement, and Seller having sole control over the defense of any allegations or actions including all negotiations for settlement or compromise. If a Product is subject to a claim that it infringes the Intellectual Property Rights of a third party, Seller may, at its sole expense and option, procure for Buyer the right to continue using the Product, replace or modify the Product so as to make it noninfringing, or offer to accept return of the Product and return the purchase price less a reasonable allowance for depreciation. Notwithstanding the foregoing, Seller shall have no liability for claims of infringement based on information provided by Buyer, or directed to Products delivered hereunder for which the designs are specified in whole or part by Buyer, or infringements resulting from the modification, combination or use in a system of any Product sold hereunder. The foregoing provisions of this Section shall constitute Seller's sole and exclusive liability and Buyer's sole and exclusive remedy for infringement of Intellectual Property Rights.

20. **Taxes.** Unless otherwise indicated, all prices and charges are exclusive of excise, sales, use, property, occupational or like taxes which may be imposed by any taxing authority upon the manufacture, sale or delivery of Products.

21. **Equal Opportunity Clause.** For the performance of government contracts and where dollar value of the Products exceed \$10,000, the equal employment opportunity clauses in Executive Order 11246, VEVRAA, and 41 C.F.R. §§ 60-1.4(a), 60-741.5(a), and 60-250.4, are hereby incorporated.

01/09

## Parker Worldwide

**AE** – UAE, Dubai  
Tel: +971 4 8875600  
parker.me@parker.com

**AR** – Argentina, Buenos Aires  
Tel: +54 3327 44 4129  
falecom@parker.com

**AT** – Austria, Wiener Neustadt  
Tel: +43 (0)2622 23501-0  
parker.austria@parker.com

**AT** – Eastern Europe, Wiener Neustadt  
Tel: +43 (0)2622 23501 970  
parker.easteurope@parker.com

**AU** – Australia, Dandenong  
Tel: +61 (0)3 9768 5555  
customer.service.au@parker.com

**AZ** – Azerbaijan, Baku  
Tel: +994 50 2233 458  
parker.azerbaijan@parker.com

**BE/LX** – Belgium, Nivelles  
Tel: +32 (0)67 280 900  
parker.belgium@parker.com

**BR** – Brazil, Sao Jose dos Campos  
Tel: +55 12 4009 3504  
falecom@parker.com

**BY** – Belarus, Minsk  
Tel: +375 17 209 9399  
parker.belarus@parker.com

**CA** – Canada, Grimsby, Ontario  
Tel: +1 905-945-2274  
ipd\_canada@parker.com

**CH** – Switzerland, Etoy  
Tel: +41 (0) 21 821 02 30  
parker.switzerland@parker.com

**CL** – Chile, Santiago  
Tel: +56 (0) 2 2303 9640  
falecom@parker.com

**CN** – China, Shanghai  
Tel: +86 21 2899 5000  
INGtechnical.china@parker.com

**CZ** – Czech Republic, Klecany  
Tel: +420 284 083 111  
parker.czechrepublic@parker.com

**DE** – Germany, Kaarst  
Tel: +49 (0)2131 4016 0  
parker.germany@parker.com

**DK** – Denmark, Ballerup  
Tel: +45 43 56 04 00  
parker.denmark@parker.com

**ES** – Spain, Madrid  
Tel: +34 902 33 00 01  
parker.spain@parker.com

**FI** – Finland, Vantaa  
Tel: +358 (0)20 753 2500  
parker.finland@parker.com

**FR** – France, Contamine s/Arve  
Tel: +33 (0)4 50 25 80 25  
parker.france@parker.com

**GR** – Greece, Athens  
Tel: +30 210 933 6450  
parker.greece@parker.com

**HU** – Hungary, Budapest  
Tel: +36 1 220 4155  
parker.hungary@parker.com

**ID** – Indonesia, Tangerang  
Tel: +62 (0)21 7588 1906  
parker.id@parker.com

**IE** – Ireland, Dublin  
Tel: +353 (0)1 466 6370  
parker.ireland@parker.com

**IN** – India, Mumbai  
Tel: +91 22 6513 7081-85

**IT** – Italy, Corsico (MI)  
Tel: +39 02 45 19 21  
parker.italy@parker.com

**JP** – Japan, Tokyo  
Tel: +81 3 6408 3900  
infophj@parker.com

**KR** – South Korea, Seoul  
Tel: +82 2 559 0400  
parkerkr@parker.com

**KZ** – Kazakhstan, Almaty  
Tel: +7 7272 505 800  
parker.easteurope@parker.com

**LV** – Latvia, Riga  
Tel: +371 6 745 2601  
parker.latvia@parker.com

**MX** – Mexico, Toluca  
Tel: +52 722 275 4200  
contacto@parker.com

**MY** – Malaysia, Selangor  
Tel: +603 784 90 800  
parkermy@parker.com

**NL** – The Netherlands, Oldenzaal  
Tel: +31 (0)541 585 000  
parker.nl@parker.com

**NO** – Norway, Stavanger  
Tel: +47 (0)51 826 300  
parker.norway@parker.com

**NZ** – New Zealand, Mt Wellington  
Tel: +64 9 574 1744

**PL** – Poland, Warsaw  
Tel: +48 (0)22 573 24 00  
parker.poland@parker.com

**PT** – Portugal, Leca da Palmeira  
Tel: +351 22 999 7360  
parker.portugal@parker.com

**RO** – Romania, Bucharest  
Tel: +40 21 252 1382  
parker.romania@parker.com

**RU** – Russia, Moscow  
Tel: +7 495 645-2156  
parker.russia@parker.com

**SE** – Sweden, Spånga  
Tel: +46 (0)8 59 79 50 00  
parker.sweden@parker.com

**SG** – Singapore,  
Tel: +65 6887 6300  
parkersg@parker.com

**SK** – Slovakia, Banská Bystrica  
Tel: +421 484 162 252  
parker.slovakia@parker.com

**SL** – Slovenia, Novo Mesto  
Tel: +386 7 337 6650  
parker.slovenia@parker.com

**TH** – Thailand, Bangkok  
Tel: +66 2 186 7000  
phthailand@parker.com

**TR** – Turkey, Istanbul  
Tel: +90 216 4997081  
parker.turkey@parker.com

**TW** – Taiwan, Taipei  
Tel: +886 2 2298 8987  
enquiry.taiwan@parker.com

**UA** – Ukraine, Kiev  
Tel: +380 44 494 2731  
parker.ukraine@parker.com

**UK** – United Kingdom, Warwick  
Tel: +44 (0)1926 317878  
parker.uk@parker.com

**USA** – IPD, Huntsville  
Tel: +1 256 881 2040  
ipdcct@parker.com

**USA** – Autoclave Engineers, Erie  
Tel: +1 814 860 5700  
ipdaect@parker.com

**VN** – Vietnam, Hochi Minh City  
Tel: +84 (0)8337 546 51  
parker\_viet@parker.com

**ZA** – South Africa, Kempton Park  
Tel: +27 (0)11 961 0700  
parker.southafrica@parker.com

### WARNING

**FAILURE, IMPROPER SELECTION OR IMPROPER USE OF THE PRODUCTS AND/OR SYSTEMS DESCRIBED HEREIN OR RELATED ITEMS CAN CAUSE DEATH, PERSONAL INJURY AND PROPERTY DAMAGE.**

This document and other information from Parker Hannifin Corporation, its subsidiaries and authorized distributors provide product and/or system options for further investigation by users having technical expertise. It is important that you analyze all aspects of your application and review the information concerning the product or system in the current product catalog. Due to the variety of operating conditions and applications for these products or systems, the user, through its own analysis and testing, is solely responsible for making the final selection of the products and systems and assuring that all performance, safety and warning requirements of the application are met. The products described herein, including without limitation, product features, specifications, designs, availability and pricing, are subject to change by Parker Hannifin Corporation and its subsidiaries at any time without notice.

Proposition 65 Warning: This product contains chemicals known to the state of California to cause cancer or birth defects or other reproductive harm.

### Offer of Sale

The items described in this document are available for sale by Parker Hannifin Corporation, its subsidiaries or its authorized distributors. Any sale contract entered by Parker will be governed by the provisions stated in Parker's standard terms and conditions of sale (copy available upon request).



Instrumentation Products Division  
1005 A Cleaner Way  
Huntsville, AL 35805 • USA  
Tel: 256 881 2040  
Fax: 256 881 5072

ipd.sales@parker.com  
[www.parker.com/ipd](http://www.parker.com/ipd)  
Mobile Application: m.parker.com/ipd

Process Analytical Guide



ENGINEERING YOUR SUCCESS.