



P3FA™ / P6FA™ Flange Adapter

Flange Adapter for Manifold



Parker Phoenix Precision™ Brand

Table of Contents

Overview and Dimensional Specifications 3

Typical Assemblies 4

Model Numbering System 5



P3FA™ / P6FA™ : Flange Adapter

The Parker Phoenix™ P3FA™ or P6FA™ Flange Adapter is designed to connect to a flange by flange manifold configuration. This flange adaptation can be connected to any type of metering line, butt weld, socket weld, threaded, etc. The accessories include, two 7/16-20 UNF hex head bolts, washers, and one flange seal.



P3FA™ / P6FA™ : Dimensional Specifications

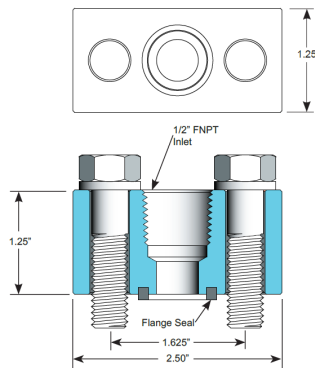

P3FA™ / P6FA™ : Typical Assemblies

Typical application of the Female NPT Flange Adapter to a Flange by Flange Manifold (exploded view)

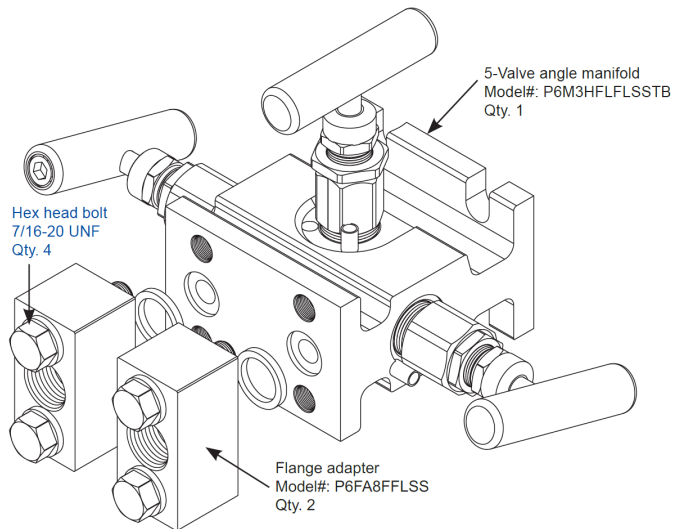

Typical application of the Female Socket Weld Flange Adapter to a Flange by Flange Manifold (assembled view)

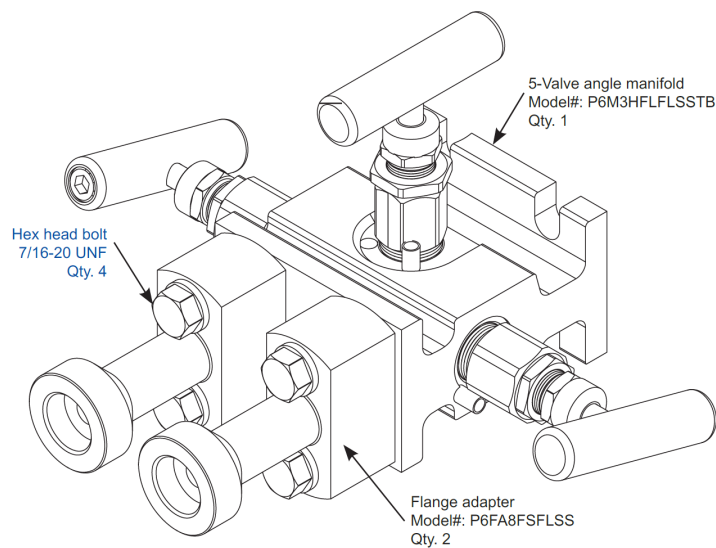

P3FA™ / P6FA™ : Model Numbering System

Phoenix	Orifice Size	Type	Inlet Size	Inlet Type	Outlet Type	Material	-	Bolt Length	Bolt Options
P	3 3/16"	FA	4 1/4"	F FNPT	FL Flange	SS ASTM A182 316/316L		175 1.75"	SS
	6 3/8"		8 1/2"	M MNPT		CS ASTM A108 CS**		200 2.0"	CS
				MS* Male Socket Weld				250 1.5"	B7M
				FS* Female Socket Weld				300 3.0"	B16
				BW Butt Weld					
EXAMPLE: P6FA8FLLSS-175SS = Flange adapter, 3/8" Bore, 1/2" FNPT Inlet, Integral Flange Outlet, 316SS, 1.75" length and stainless steel bolt									
P	6	FA	8	F	FL	SS	-	175	SS
Note: Standard Bolting Options, CS - carbon steel, Gr.8, zinc plated bolts; SS - stainless steel, 18.8 (304SS) bolts.									

Use with Confidence, Parker Phoenix Precision Products Meet the Following Specifications:

- ASME B31.1 Power Piping
- ASME B31.3 Process Piping
- ASME B16.34 Valves - Flanged, Thread, and Welding End
- API 598 Valve Inspection and Testing
- MSS SP-25 Standard Marking Systems for Valves, Fittings and Flange Unions
- MSS SP-99 Instrument Valves
- MSS SP-105 Instrument Valves for Code Applications
- NACE MR0175 for all 316SS valves and A105CS body/316SS bonnet (SC Material Code)

Parker Hannifin Corporation
Instrumentation Products Division
1005 A Cleaner Way
Huntsville, AL 35805 USA
phone 256 881 2040
fax 256 881 5072
www.parker.com/ipd

Parker Phoenix P3FA™/ P6FA™ - Flange Adapter
PPL-CAT-P3FA-P6FA-001 May 2024

© 2024 Parker Hannifin Corporation



parker.com/ipd