

AC Mn



AC servo motors



Product Manual

03-05-02-E-V2005.doc



Further descriptions, that relate to this document:

UL: 05-01-08



Planetary Gearbox PG AP - Product-manual

UL: 05-01-06



Planetary Gearbox PG AL - Product-manual

UL: 05-01-07



Planetary Gearbox PG AF - Product-manual

UL: 12-01



Plugs - Product description

UL: 12-02-01



Cables - Product description

©SSD Drives GmbH.

All rights reserved. No portion of this description may be produced or processed in any form without the consent of the company.

Changes are subject to change without notice.

SSD Drives has registered in part trademark protection and legal protection of designs. The handing over of the descriptions may not be construed as the transfer of any rights.

Made in Germany, 2005

CONTENTS

	page
The most important thing first	4
1 General	5
1.1 Description	5
1.2 Type code	6
1.2.1 Typical example.....	6
1.3 Possible options (Marking: g)	7
2 General technical data	8
3 Technical data.....	9
3.1 Torque/Speed Diagrams.....	11
3.1.1 Motor size 0	11
3.1.2 Motor size 1	12
3.1.3 Motor size 2	13
3.1.4 Motor size 3	14
4 Dimensions	15
4.1 Standard design Motor size <u>0...3</u>	15
4.1.1 Connections via connectors	15
4.2 <u>Special</u> design Motor size <u>0...3</u>	16
4.2.1 Connections via PG couplings and cables	16
4.2.2 Motor with <u>pulse encoder attachment preparation</u> for incremental encoder DG60 resp. ROD426 for motor size <u>1 - 3</u>	16
5 Connector assignment.....	17
5.1 Motor connection for standard design Pin assignment for SSD Drives motors, size <u>0...3</u>	17
5.1.1 SSD Drives-servo drives 635/DER / 637/D6R in the <u>SSD Drives Rack</u>	17
5.1.2 SSD Drives-servo drive 635/K DER in the <u>compact enclosure</u>	18
5.1.3 SSD Drives-servo drive 637/K D6R in the <u>compact enclosure</u>	19
5.1.4 SSD Drives-servo drive (old product FRR AC S) in the <u>compact enclosure</u>	20
5.2 Motor connection for <u>special</u> design (Connections via PG with cable ends)	21
5.2.1 SSD Drives-servo drives 635/DER / 637/D6R	21
5.2.2 SSD Drives-servo drive 635/K DER in the <u>compact- or low cost enclosure</u>	21
5.2.3 SSD Drives-servo drive 637/K D6R in the <u>compact enclosure</u>	22
5.2.4 SSD Drives-servo drive (old product FRR AC S) in the <u>compact enclosure</u>	22
5.3 Resolver connection	23
5.3.1 <u>Special</u> design with the cables PG-coupling	24
5.4 Cabling instructions	25
5.5 Plug designation	26
5.5.1 Mating plugs for motor- and brake connections	26
5.5.2 Mating plugs for resolver- and thermal connection	26
6 Technical data of the holding brake	27
7 Shaft loads	28
7.1 <u>radial</u> shaft load	28
7.1.1 Representation of the definition.....	28
7.1.2 technical dates of the max. radial shaft load FR (N)	28
7.2 <u>axial</u> shaft load	28
7.2.1 Representation of the definition.....	28
7.2.2 technical dates of the max. axial shaft load FA (N)	28
7.3 Use Ball bearing type.....	28
8 Nominal power dependence of the SSD Drives AC servo motors concerning the installation altitude.....	29
8.1 Short description.....	29
9 Modification Record	30



The most important thing first

Thanks for your confidence choosing our product.

These operating instructions present themselves as an overview of the technical data and features.

Please read the operating instructions before operating the product.

If you have any questions, please contact your nearest SSD Drives representative. Improper application of the product in combination with dangerous voltage can lead to injuries.

In addition, damage can also occur to motors or other products. Therefore please observe our safety precautions strictly.

Safety precautions

We assume that, as an expert, you are familiar with the relevant safety regulations, especially in accordance with VDE 0100, VDE 0113, VDE 0160, EN 50178, the accident prevention regulations of the employers liability insurance company and the DIN regulations and that you are able to use and apply them.

As well, relevant European Directives must be observed.

Depending on the kind of application, additional regulations e.g. UL, DIN are subject to be observed.

If our products are operated in connection with components from other manufacturers, their operating instructions are also subject to be observed strictly.

1 General

1.1 Description

By using high-energy magnetic materials it is possible to design small diameter disk motors. For this reason and due to a carefully optimized technical construction of the rotor, the motors have a low moment of inertia.

The stability of the magnetic material and the design of the magnetic field in the face of demagnetization allow maximum currents of up to **3- 4 times the rated current**.

The high acceleration capacity of the low-inertia three-phase AC servo drives is the result of this.

Through the excitation of the permanent magnets, no heat losses due to current occur in the rotor.

With the three-phase AC-servomotors heat losses due to current occur only in the stator, which then can be directly drawn off.

These favorable cooling conditions allow high-capacity windings.

Since all the current heat losses are drawn off directly via the surface, the motors are designed at low cost with the enclosure type providing protection in accordance with **IP xx** and they are thus very insensitive to liquids and dirt.

The resolver is built into the B-side bearing bracket.

The signals of this integrated measuring system for the actual speed value, the rotor position and the indirect position are taken at the motor over a 12-pin connector.

Synchronous three-phase AC servo drives have a series of advantages over the DC drives:

- no electromechanical parts to wear out, therefore "maintenance-free".
- a low moment of inertia of the rotor due to power density, therefore high acceleration capacity.
- no commutation limit curve, therefore high acceleration moments, also in higher speed ranges.
- no losses in the rotor of the motor, therefore favorable thermal characteristics and a high degree of protection due to the closed construction.

Three-phase AC servomotors built in the way described, are specifically more efficient (higher rated torque) than DC servomotors and also have a small inertia. Therefore the size necessary for an application will, for this reason, be smaller with three-phase AC servos than with DC servos.

Important !

- The motor series AC G is not attachment- or pin-compatible to our drives AC M or AC R.
- Motor design AC G only in standard.



General

1.2 Type code

Marking	Standard						optional	
	a	b	c	d	e	f	g	h
Type:	AC	XXX	XXXX	-X	/X	-X	XX	+ ...

Marking	Description
a	AC = three-phase
b	motor models: <u>G</u> = motor series <u>G</u> without cases <u>M</u> = motor series (old) <u>Mn</u> = motor series <u>n</u> ew <u>M2n</u> = motor series 2 nd <u>n</u> ew version <u>MHS</u> = motor series <u>H</u> iperface <u>S</u> ingleturn (under preparation) <u>MHM</u> = motor series <u>H</u> iperface <u>M</u> ultiturn <u>R</u> = motor series <u>R</u> <u>R(L)</u> = motor series <u>RL</u> with separate fan
c	xxxx = approx. rated torque in Ncm
d	-4 = 4000 rpm at motor type: "AC G; AC Mn; AC M2n; AC MHx" 1.6 = *1000 1/min at motor type: "AC R" -X = further on request (designation does not apply with motor / gearbox systems)
e	/Y..4 = motor size (designation does not apply with motor / gearbox systems)
f	-3 = 325 V DC intermediate circuit rated voltage (≅ 230 VAC) -6 = 565 V DC intermediate circuit rated voltage (≅ 400 VAC)
g	identification for options and custom features XX = see chapter 1.3
h	+ ... = with attached gear-box: (for short description for inserted gearbox models see gearbox documentation)

Note:

Up to marking "g" it is only necessary with options or custom features.

No options are possible for the AC G drive.

1.2.1 Typical example

A typical example of an order corresponding to the model key would be:

Type: AC <u>G</u> 0090-4/01-3	Type: AC <u>Mn</u> 0320-4/2-3	Type: AC <u>R</u> 0095-6/1-3
AC = three phase	AC = three phase	AC = three phase
G = motor series	Mn = motor series new	R = motor series
0090 = rated torque in Ncm	0320 = rated torque in Ncm	0068 = rated torque in Ncm
-4 = 4000 rpm	-4 = 4000 rpm	-6 = 6000 rpm
/01 = motor size	/2 = motor size	/1 = motor size
-3 = 325V DC (230 VAC)	-3 = 325V DC	-3 = 325V DC

General

1.3 Possible options (Marking: g)

Marking	Options			and Marking	Description	motor types			
	BR	GW	IP 65			A C G	A C M n	A C M 2n	A C R
GW		X			smooth motor shaft	<input type="checkbox"/>	<input checked="" type="checkbox"/>	<input checked="" type="checkbox"/>	<input checked="" type="checkbox"/>
BR	X				holding brake, 24V DC	<input type="checkbox"/>	<input checked="" type="checkbox"/>	<input checked="" type="checkbox"/>	<input checked="" type="checkbox"/>
BBR	X				holding brake type B 24V DC	<input type="checkbox"/>	<input type="checkbox"/>	<input checked="" type="checkbox"/>	<input checked="" type="checkbox"/>
65			X		degree of protection IP 65	<input type="checkbox"/>	<input checked="" type="checkbox"/>	<input checked="" type="checkbox"/>	<input checked="" type="checkbox"/>
BG	X	X				<input type="checkbox"/>	<input checked="" type="checkbox"/>	<input checked="" type="checkbox"/>	<input checked="" type="checkbox"/>
AI					absolute or incremental encoder preparation of attachment	<input type="checkbox"/>	<input checked="" type="checkbox"/>	<input checked="" type="checkbox"/>	<input checked="" type="checkbox"/>
BI	X			AI		<input type="checkbox"/>	<input checked="" type="checkbox"/>	<input checked="" type="checkbox"/>	<input type="checkbox"/>
PL					electrical connections via PG couplings and cable ends	<input type="checkbox"/>	<input checked="" type="checkbox"/>	<input checked="" type="checkbox"/>	<input checked="" type="checkbox"/>
2P					2 nd featherkey way	<input type="checkbox"/>	<input checked="" type="checkbox"/>	<input checked="" type="checkbox"/>	<input checked="" type="checkbox"/>
6P			X	2P		<input type="checkbox"/>	<input checked="" type="checkbox"/>	<input checked="" type="checkbox"/>	<input checked="" type="checkbox"/>
90					flange receptacle for motor and resolver 90° angled	<input type="checkbox"/>	<input checked="" type="checkbox"/>	<input checked="" type="checkbox"/>	<input type="checkbox"/>
GP		X		PL		<input type="checkbox"/>	<input checked="" type="checkbox"/>	<input checked="" type="checkbox"/>	<input type="checkbox"/>
G6		X	X			<input type="checkbox"/>	<input checked="" type="checkbox"/>	<input checked="" type="checkbox"/>	<input checked="" type="checkbox"/>
MS					mech. custom designs	<input type="checkbox"/>	<input checked="" type="checkbox"/>	<input checked="" type="checkbox"/>	<input checked="" type="checkbox"/>
PU				PL	unpainted motor	<input type="checkbox"/>	<input checked="" type="checkbox"/>	<input checked="" type="checkbox"/>	<input checked="" type="checkbox"/>
PS		X		PU		<input type="checkbox"/>	<input checked="" type="checkbox"/>	<input checked="" type="checkbox"/>	<input type="checkbox"/>
SL					special finish	<input type="checkbox"/>	<input checked="" type="checkbox"/>	<input checked="" type="checkbox"/>	<input checked="" type="checkbox"/>
GK		X			smooth motor shaft shortend	<input type="checkbox"/>	<input checked="" type="checkbox"/>	<input checked="" type="checkbox"/>	<input checked="" type="checkbox"/>
VA	X	X		PL		<input type="checkbox"/>	<input checked="" type="checkbox"/>	<input checked="" type="checkbox"/>	<input type="checkbox"/>
R6			X		rust-proof motor shaft	<input type="checkbox"/>	<input checked="" type="checkbox"/>	<input checked="" type="checkbox"/>	<input type="checkbox"/>
P6			X	PL		<input type="checkbox"/>	<input checked="" type="checkbox"/>	<input checked="" type="checkbox"/>	<input type="checkbox"/>
B6	X		X			<input type="checkbox"/>	<input checked="" type="checkbox"/>	<input checked="" type="checkbox"/>	<input checked="" type="checkbox"/>
F6			X		flange receptacle B-side	<input type="checkbox"/>	<input checked="" type="checkbox"/>	<input checked="" type="checkbox"/>	<input type="checkbox"/>
VI	X	X		AI		<input type="checkbox"/>	<input checked="" type="checkbox"/>	<input checked="" type="checkbox"/>	<input checked="" type="checkbox"/>
GI		X		AI		<input type="checkbox"/>	<input checked="" type="checkbox"/>	<input checked="" type="checkbox"/>	<input checked="" type="checkbox"/>
V6	X	X	X			<input type="checkbox"/>	<input checked="" type="checkbox"/>	<input checked="" type="checkbox"/>	<input checked="" type="checkbox"/>
L6		X	X	PL		<input type="checkbox"/>	<input checked="" type="checkbox"/>	<input checked="" type="checkbox"/>	<input type="checkbox"/>
BL	X		X	PL		<input type="checkbox"/>	<input checked="" type="checkbox"/>	<input checked="" type="checkbox"/>	<input type="checkbox"/>
B4	X				flange B 14	<input type="checkbox"/>	<input checked="" type="checkbox"/>	<input checked="" type="checkbox"/>	<input type="checkbox"/>
VR		X		PL+R6+AI		<input type="checkbox"/>	<input checked="" type="checkbox"/>	<input checked="" type="checkbox"/>	<input type="checkbox"/>
S6			X	PL+R6+2P		<input type="checkbox"/>	<input checked="" type="checkbox"/>	<input checked="" type="checkbox"/>	<input type="checkbox"/>
GZ		X			with Centre hole	<input type="checkbox"/>	<input checked="" type="checkbox"/>	<input checked="" type="checkbox"/>	<input type="checkbox"/>
N6		X	X		with special rotation speed about software (6000)	<input type="checkbox"/>	<input checked="" type="checkbox"/>	<input checked="" type="checkbox"/>	<input type="checkbox"/>
HW		X			with Hollow shaft	<input type="checkbox"/>	<input checked="" type="checkbox"/>	<input checked="" type="checkbox"/>	<input type="checkbox"/>
T6			X		for tropical climate	<input type="checkbox"/>	<input checked="" type="checkbox"/>	<input checked="" type="checkbox"/>	<input type="checkbox"/>
X6				F6 + 2P		<input type="checkbox"/>	<input checked="" type="checkbox"/>	<input checked="" type="checkbox"/>	<input type="checkbox"/>

* only motor size 3

- standard design
- ◐ optional
- not possible

2 General technical data

		A C	A C	A C	A C
		<u>G</u>	<u>M</u> <u>n</u>	<u>M</u> <u>2</u> <u>n</u>	<u>R</u>
Degree of protection: with mounted mating connectors and built-on motor	IP44 (with separate fan)	<input type="checkbox"/>	<input type="checkbox"/>	<input type="checkbox"/>	<input checked="" type="checkbox"/>
	IP54	<input checked="" type="checkbox"/>	<input checked="" type="checkbox"/>	<input checked="" type="checkbox"/>	<input type="checkbox"/>
	IP65	<input type="checkbox"/>	<input checked="" type="checkbox"/>	<input checked="" type="checkbox"/>	<input checked="" type="checkbox"/>
Magnetic material:	NdFeB	<input checked="" type="checkbox"/>	<input checked="" type="checkbox"/>	<input checked="" type="checkbox"/>	<input type="checkbox"/>
	SE	<input type="checkbox"/>	<input type="checkbox"/>	<input type="checkbox"/>	<input checked="" type="checkbox"/>
Electrical connections:	straight flanged sockets	<input type="checkbox"/>	<input checked="" type="checkbox"/>	<input type="checkbox"/>	<input checked="" type="checkbox"/>
	rotatable 90° angled for motor-, resolver- and thermal connection-flanged sockets	<input checked="" type="checkbox"/>	<input type="checkbox"/>	<input checked="" type="checkbox"/>	<input type="checkbox"/>
	PG couplings with cable ends	<input checked="" type="checkbox"/>	<input checked="" type="checkbox"/>	<input checked="" type="checkbox"/>	<input type="checkbox"/>
Thermal protection of motor:	thermal detector PTC	<input checked="" type="checkbox"/>	<input checked="" type="checkbox"/>	<input checked="" type="checkbox"/>	<input checked="" type="checkbox"/>
Power:	In accordance with DIN VDE 0530 installation site: 1000 ASL T = 100K, Tu 40°C measured with attached cooling surface	<input checked="" type="checkbox"/>	<input checked="" type="checkbox"/>	<input checked="" type="checkbox"/>	<input checked="" type="checkbox"/>
Voltage:	325 V DC	<input checked="" type="checkbox"/>	<input checked="" type="checkbox"/>	<input checked="" type="checkbox"/>	<input checked="" type="checkbox"/>
	565 V DC	<input type="checkbox"/>	<input checked="" type="checkbox"/>	<input checked="" type="checkbox"/>	<input checked="" type="checkbox"/>
	other windings are possible.	<input type="checkbox"/>	<input checked="" type="checkbox"/>	<input checked="" type="checkbox"/>	<input type="checkbox"/>
Cooling:	self-cooling	<input checked="" type="checkbox"/>	<input checked="" type="checkbox"/>	<input checked="" type="checkbox"/>	<input checked="" type="checkbox"/>
	separate cooling	<input type="checkbox"/>	<input type="checkbox"/>	<input type="checkbox"/>	<input checked="" type="checkbox"/>
Operating mode:	Continuous operation S1	<input checked="" type="checkbox"/>	<input checked="" type="checkbox"/>	<input checked="" type="checkbox"/>	<input checked="" type="checkbox"/>
Bearings:	Ball bearings, service life approx. 15.000 h	<input checked="" type="checkbox"/>	<input checked="" type="checkbox"/>	<input checked="" type="checkbox"/>	<input checked="" type="checkbox"/>
Motor shaft: (standard)	with fitting key in accordance with DIN 6885	<input checked="" type="checkbox"/>	<input checked="" type="checkbox"/>	<input checked="" type="checkbox"/>	<input checked="" type="checkbox"/>
Rotational accuracy:	N, in acc. with DIN ISO 2373	<input checked="" type="checkbox"/>	<input checked="" type="checkbox"/>	<input checked="" type="checkbox"/>	<input checked="" type="checkbox"/>
Number of pole pairs:	2	<input type="checkbox"/>	<input type="checkbox"/>	<input type="checkbox"/>	<input checked="" type="checkbox"/>
	3	<input checked="" type="checkbox"/>	<input checked="" type="checkbox"/>	<input checked="" type="checkbox"/>	<input checked="" type="checkbox"/>
Resolver type:	2 pole SSD Drives resolver	<input checked="" type="checkbox"/>	<input checked="" type="checkbox"/>	<input checked="" type="checkbox"/>	<input type="checkbox"/>
	2 pole standard transmitter resolver	<input type="checkbox"/>	<input type="checkbox"/>	<input type="checkbox"/>	<input checked="" type="checkbox"/>
Insulation class	F (VDE 0530) 155° C, heating 100° K	<input checked="" type="checkbox"/>	<input checked="" type="checkbox"/>	<input checked="" type="checkbox"/>	<input checked="" type="checkbox"/>
Varnish: (standard)	similar RAL 9005 (black)	<input checked="" type="checkbox"/>	<input checked="" type="checkbox"/>	<input checked="" type="checkbox"/>	<input checked="" type="checkbox"/>

- standard design
- optional
- not possible

- ★ dependent on size
- ◆ only with larger quantities

3 Technical data

Model: AC Mn

AC-Servo motor Model:	size	Technical data				Static torque	max. Static torque	Static current	Moment of inertia included Resolver
		Nominal power	Rated torque	Rated current with 325V DC 565V DC					
		PN (KW)	MN (Nm)	IN325 (A)	IN565 (A)	M0 (Nm)	Momax (Nm)	I0 (A)	JM (kgcm ²)
AC Mn0010-4/0-3	0.0	0,04	0,1	0,2	-	0,13	0,4	0,25	0,05
AC Mn0030-4/0-3	0.1	0,13	0,3	0,8	-	0,33	1	0,9	0,1
AC Mn0045-4/0-3	0.2	0,2	0,45	1,08	-	0,5	1,8	1,2	0,15
AC Mn0045-4/0-6		0,2	0,45	-	0,6	0,5	1,8	0,65	0,15
AC Mn0070-4/0-3	0.3	0,29	0,7	1,46	-	0,77	2,5	1,6	0,2
AC Mn0070-4/0-6		0,29	0,7	-	0,82	0,77	2,5	0,9	0,2
AC Mn0090-4/1-3	1.0	0,38	0,9	1,8	-	1,5	3,5	3	0,68
AC Mn0090-4/1-6		0,38	0,9	-	1,1	1,5	3,5	1,8	0,68
AC Mn0150-4/1-3	1.1	0,63	1,5	3,3	-	2,5	6	5	1
AC Mn0150-4/1-6		0,63	1,5	-	1,9	2,5	6	2,7	1
AC Mn0220-4/1-3	1.2	0,92	2,2	4,7	-	3	9	6,4	1,3
AC Mn0220-4/1-6		0,92	2,2	-	2,8	3	9	3,8	1,3
¹⁾ AC Mn0070-12/2-3	2.0	0,88	0,7	7	-	1,5		15	0,55
AC Mn0320-4/2-3	2.1	1,34	3,2	6,4	-	4	13	8,6	2,7
AC Mn0320-4/2-6		1,34	3,2	-	3,2	4	13	4,3	2,7
AC Mn0480-4/2-3	2.2	2	4,8	11,2	-	7	19	13,6	3,4
AC Mn0480-4/2-6		2	4,8	-	5,6	7	19	6,8	3,4
²⁾ AC Mn0600-1/2-3		0,75	6	6	-	7	19	6,8	3,4
AC Mn0650-4/2-3	2.3	2,72	6,5	12	-	9	26	16,4	4,5
AC Mn0650-4/2-6		2,72	6,5	-	6	9	26	8,3	4,5
AC Mn0960-4/3-3	3.1	4	9,6	19,3	-	16	38	32	6
AC Mn0960-4/3-6		4	9,6	-	12	16	38	19	6
AC Mn1200-4/3-3	3.2	5	12	25	-	21	48	42	7,5
AC Mn1200-4/3-6		5	12	-	15	21	48	25	7,5

¹⁾ Data at rated speed of 4000 rpm

¹⁾ Data at rated speed of 12000 rpm

²⁾ Data at rated speed of 1200 rpm

Note: Drives of motor size 4 see AC R type series!



Technical data

Model: **AC Mn**

AC-Servo motor Model:	size	Mass	Motor resistance	Motor inductance	Thermal time constant		Torque constant	e.m.f constant eff.
					with IN	with Imax		
		m (kg)	Rph/ph (Ω)	Lph/ph (mH)	TthN (min)	Tthmax (s)	KT (Nm/A)	KE (V/1000 min-1)
AC Mn0010-4/0-3	0.0	0,83	112	63	7	18	0,5	30
AC Mn0030-4/0-3	0.1	1,15	18,5	15	10	26	0,4	24
AC Mn0045-4/0-3	0.2	1,5	12	10	12	31	0,41	25
AC Mn0045-4/0-6		1,5	30	28	12	31	0,74	45
AC Mn0070-4/0-3	0.3	1,9	8,5	8,5	14	36	0,5	30
AC Mn0070-4/0-6		1,9	23	23	14	36	0,83	50
AC Mn0090-4/1-3	1.0	2,7	3,1	10	20	51	0,5	30
AC Mn0090-4/1-6		2,7	8,5	24	20	51	0,83	50
AC Mn0150-4/1-3	1.1	3,5	2,2	6	23	59	0,5	30
AC Mn0150-4/1-6		3,5	5	15	23	59	0,94	57
AC Mn0220-4/1-3	1.2	4,7	1,1	4,2	26	66	0,5	30
AC Mn0220-4/1-6		4,7	2,8	11	26	66	0,83	50
¹⁾ AC Mn0070-12/2-3	2.0	4,85	0,78	2,95	-	-	0,1	6
AC Mn0320-4/2-3	2.1	5,6	1,2	5,1	19	49	0,5	30
AC Mn0320-4/2-6		5,6	3,4	16	19	49	0,99	60
AC Mn0480-4/2-3	2.2	8,2	0,5	2,7	29	74	0,5	30
AC Mn0480-4/2-6		8,2	2,1	12,3	29	74	0,99	60
²⁾ AC Mn0600-1/2-3		8,2	2,1	12,3	29	74	0,99	60
AC Mn0650-4/2-3	2.3	10,6	0,6	2,6	38	97	0,55	33
AC Mn0650-4/2-6		10,6	2	10	38	97	1,09	60
AC Mn0960-4/3-3	3.1	19,0	0,32	2,9	36	92	0,5	30
AC Mn0960-4/3-6		19,0	0,75	8,7	36	92	0,83	50
AC Mn1200-4/3-3	3.2	23,0	0,14	1,5	52	133	0,5	30
AC Mn1200-4/3-6		23,0	0,38	4,1	52	133	0,83	50

Data at rated speed of 4000 rpm

¹⁾ Data at rated speed of 12000 rpm

²⁾ Data at rated speed of 1200 rpm

Note: Drives of motor size 4 see AC R type series!

Technical data

3.1 Torque/Speed Diagrams

3.1.1 Motor size 0

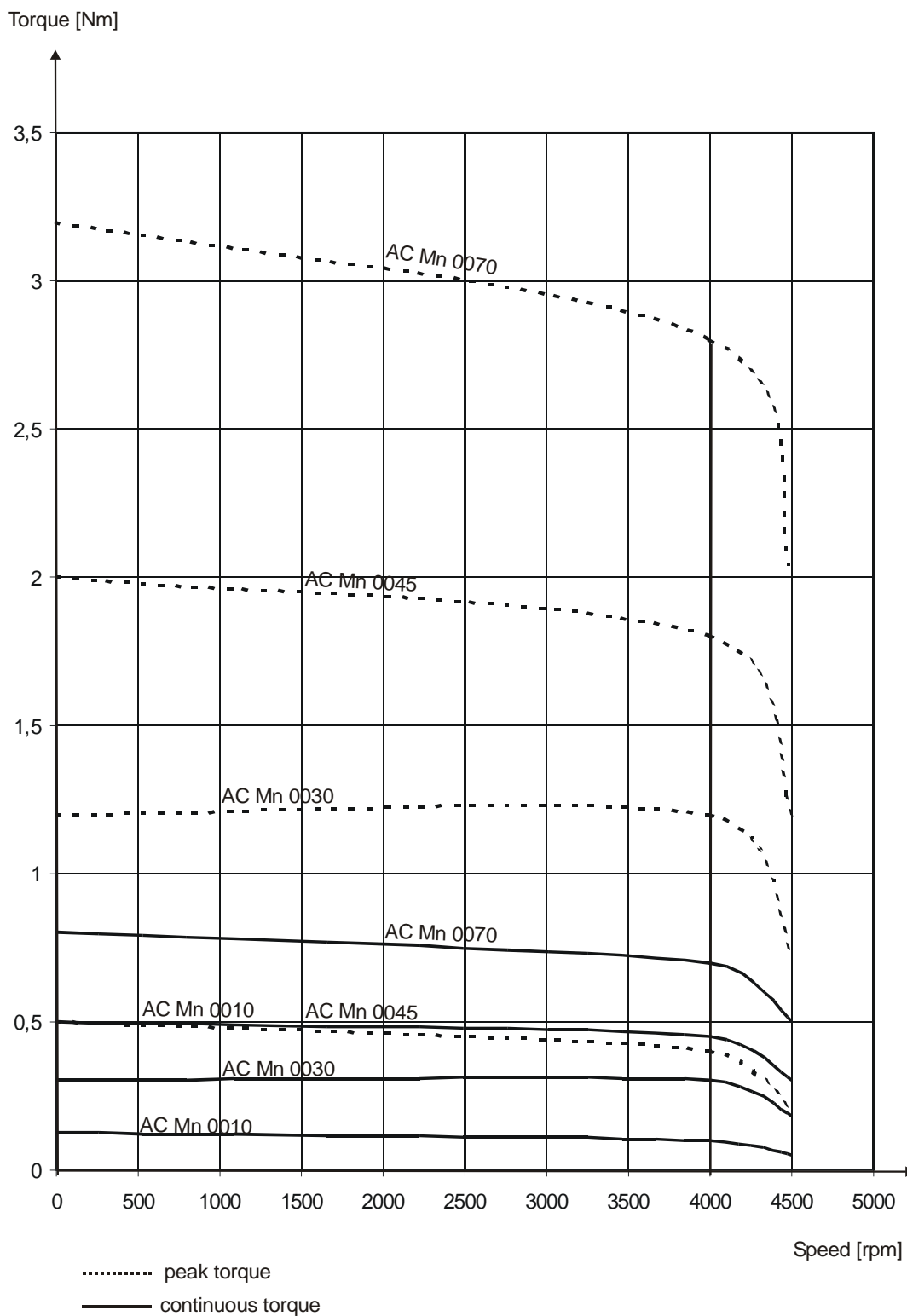



Technical data

Torque/Speed Diagrams

3.1.2 Motor size 1

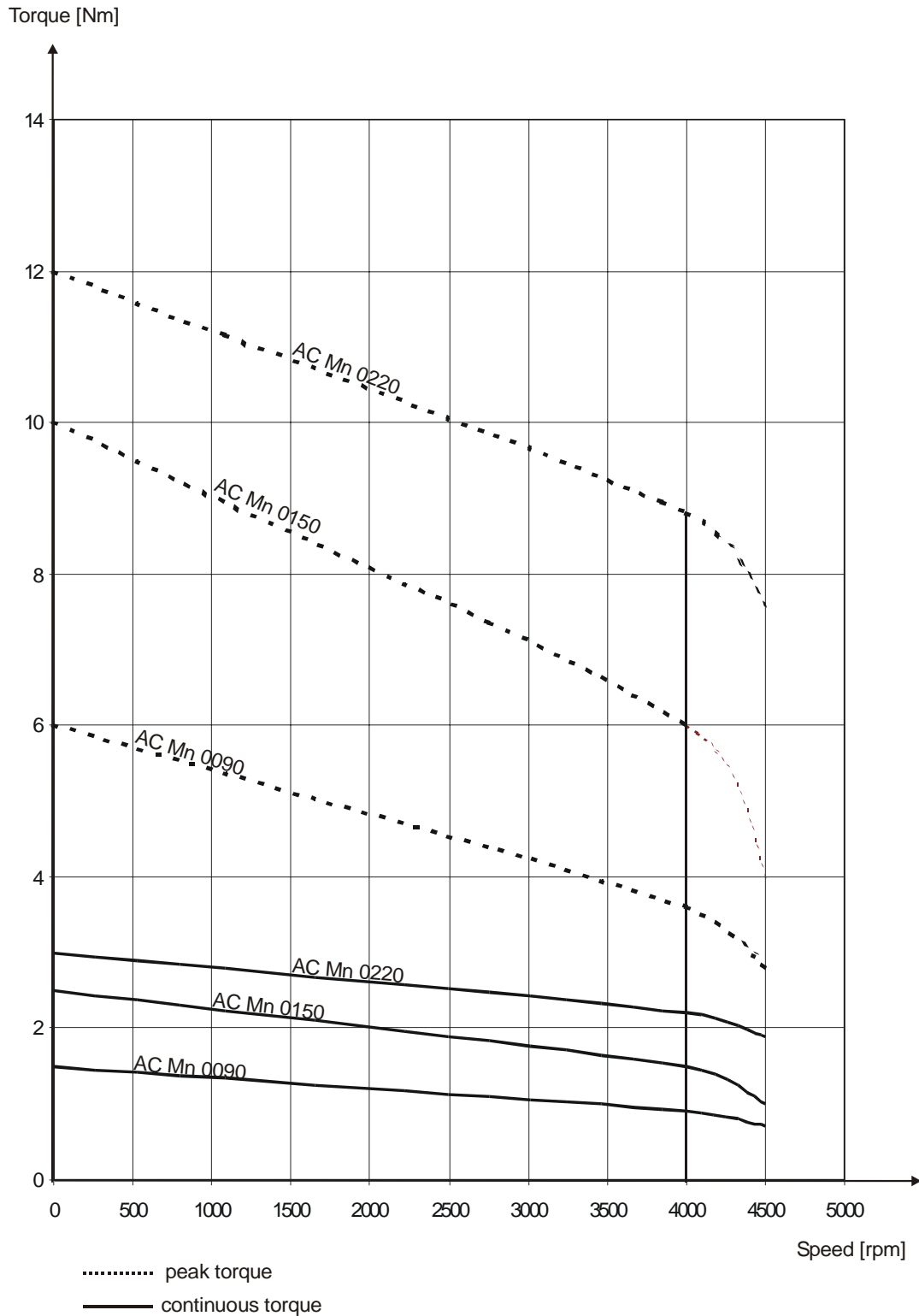

Technical data

Torque/Speed Diagrams

3.1.3 Motor size 2

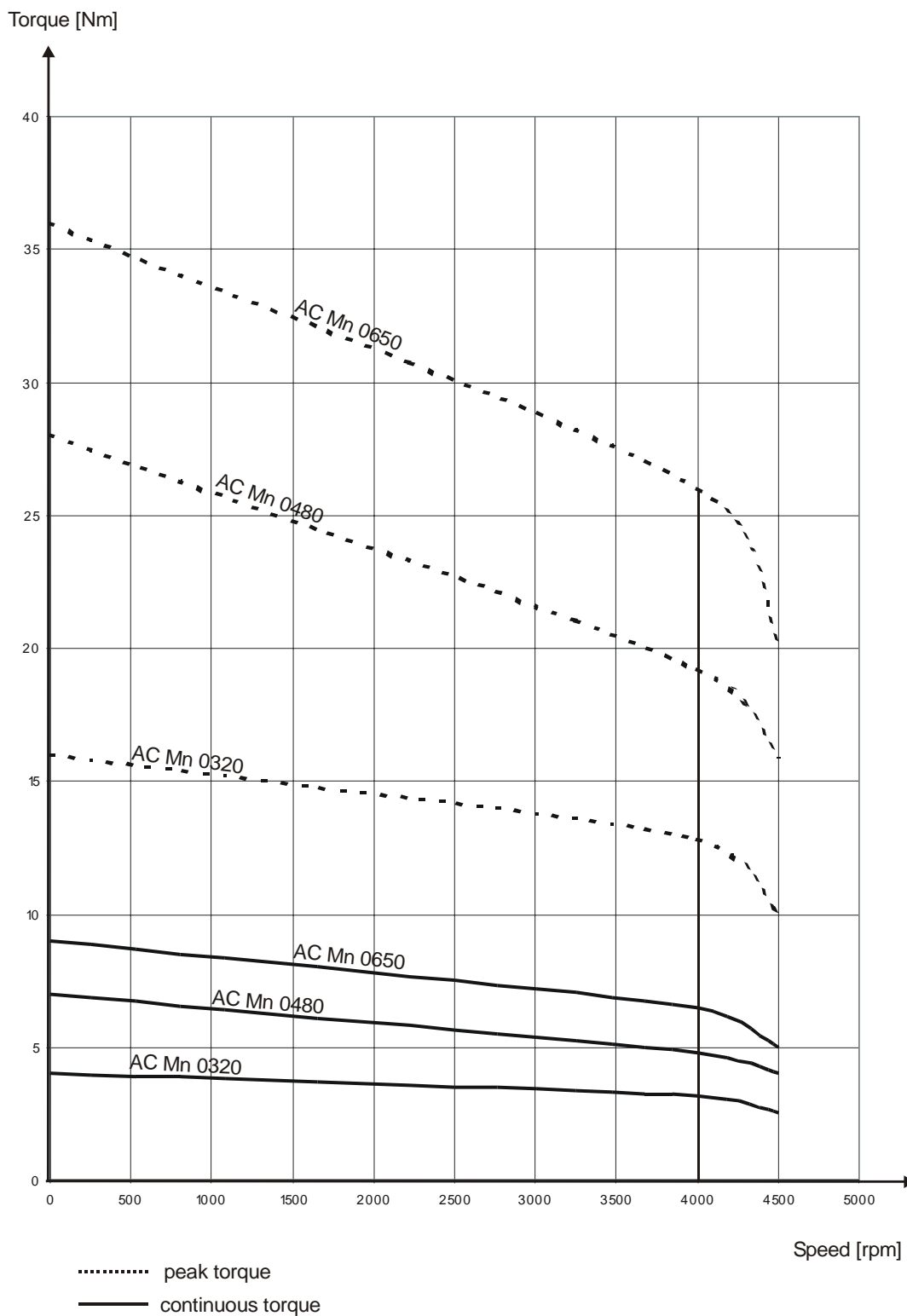



Technical data

Torque/Speed Diagrams

3.1.4 Motor size 3

Torque [Nm]

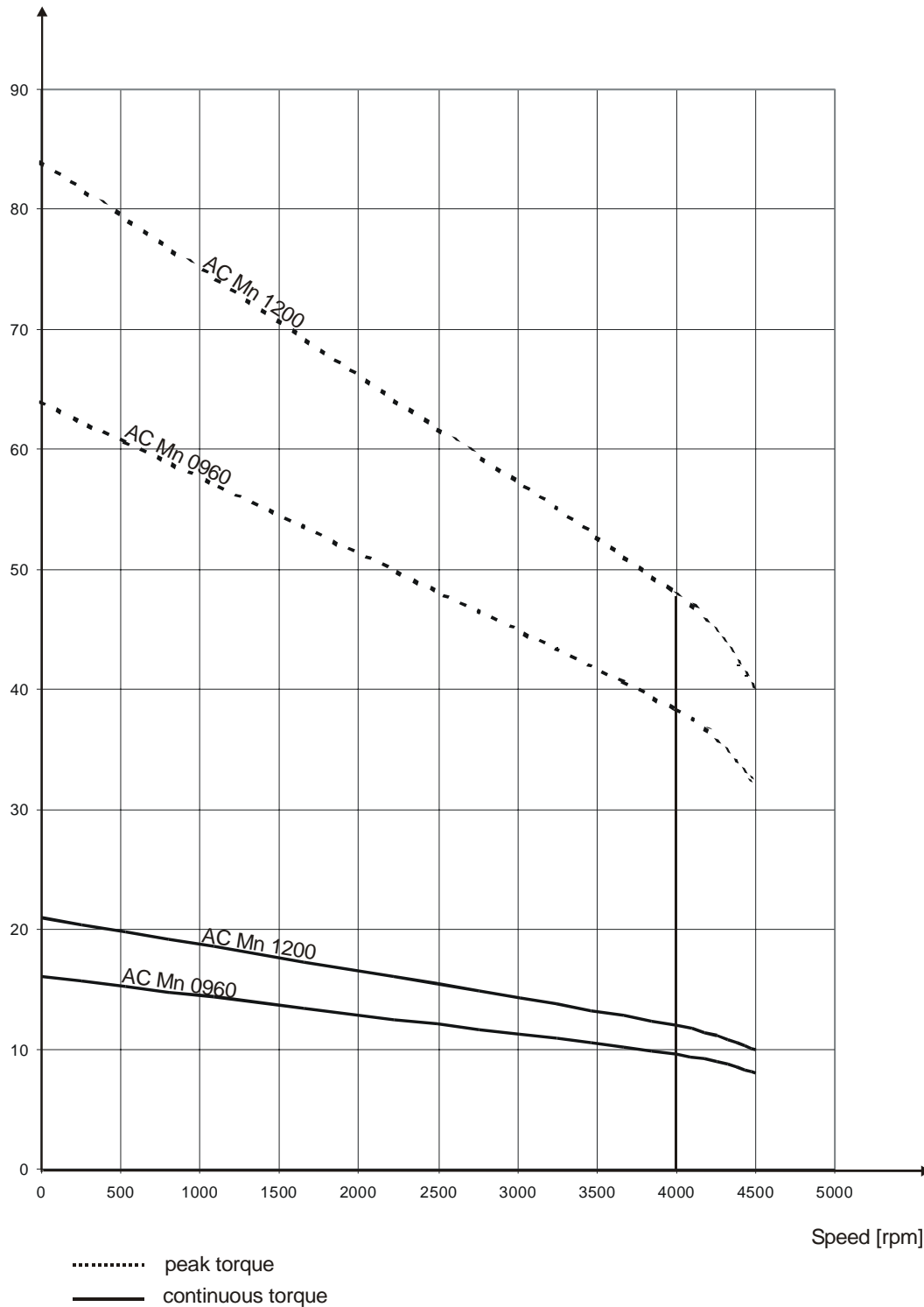

4 Dimensions

4.1 Standard design Motor size 0...3

4.1.1 Connections via connectors

Please observe the bending radius of the cable !

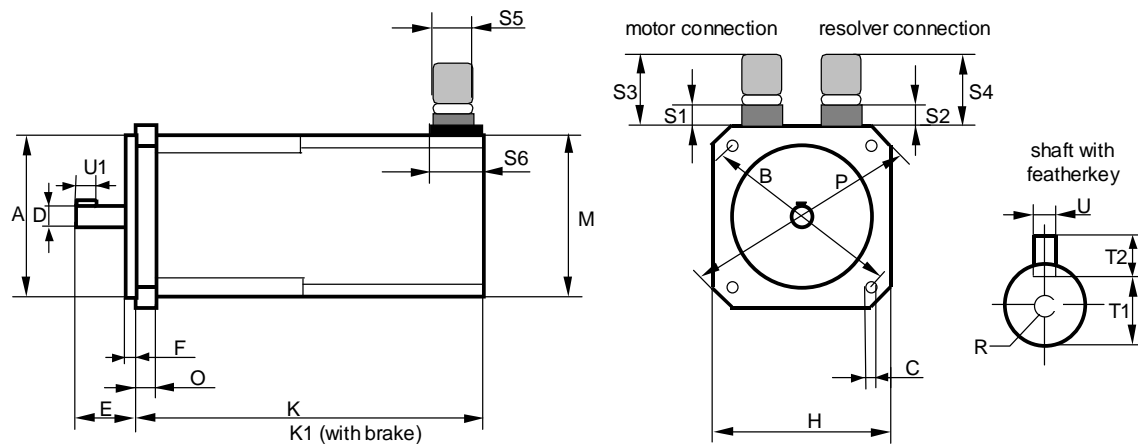

Size	Motor				Resolver			
	S1	S3	S5	S6	S2	S4	S5	S6
0	28,0	88,0	28,0	30,0	31,0 - 34,0	71,0 - 74,0	26,0	25,4
1	16,0	76,0	28,0	30,0	21,0 - 24,0	61,0 - 64,0	26,0	25,4
2	16,0	76,0	28,0	30,0	21,0 - 24,0	61,0 - 64,0	26,0	25,4
3	25,0	96,0	35,6	38,0	21,0 - 24,0	61,0 - 64,0	26,0	25,4

Model AC Mn	BG	A (j6)	B	C	D (k6)	E	F	H	K	K1	M	O	P	R	T1	T2 (h9)	U (h9)	U1
0010-4/0-3	0.0	40	63	5,8	9	24	2,5	55	94	126	55	8	74	M3-10	7,2	3	3	14
0030-4/0-3	0.1	40	63	5,8	9	24	2,5	55	116	155	55	8	74	M3-10	7,2	3	3	14
0045-4/0-x	0.2	40	63	5,8	9	24	2,5	55	138	171	55	8	74	M3-10	7,2	3	3	14
0070-4/0-x	0.3	40	63	5,8	9	24	2,5	55	158	191	55	8	74	M3-10	7,2	3	3	14
0090-4/1-x	1.0	80	100	7	14	30	3	88	132	173	82	10	115	M4-12	11,1	5	5	20
0150-4/1-x	1.1	80	100	7	14	30	3	88	151	193	82	10	115	M4-12	11,1	5	5	20
0220-4/1-x	1.2	80	100	7	14	30	3	88	171	213	82	10	115	M4-12	11,1	5	5	20
0070-12/2-3	2.0	95	115	9	19	40	3	105	160	-	105	12	134	M6-15	15,5	6	6	30
0320-4/2-x	2.1	95	115	9	19	40	3	105	200	240	105	12	134	M6-15	15,5	6	6	30
0480-4/2-x	2.2	95	115	9	19	40	3	105	230	270	105	12	134	M6-15	15,5	6	6	30
0600-4/2-x	2.	95	115	9	19	40	3	105	230	-	105	12	134	M6-15	15,5	6	6	30
0650-4/2-x	2.3	95	115	9	19	40	3	105	280	315	105	12	134	M6-15	15,5	6	6	30
0960-4/3-x	3.1	130	165	11	24	50	3,5	145	300	345	145	12	188	M8-25	19,9	8	8	40
1200-4/3-x	3.2	130	165	11	24	50	3,5	145	340	383	145	12	188	M8-25	19,9	8	8	40

all dimensions in "mm"

Dimensions

4.2 Special design Motor size 0...3

4.2.1 Connections via PG couplings and cables

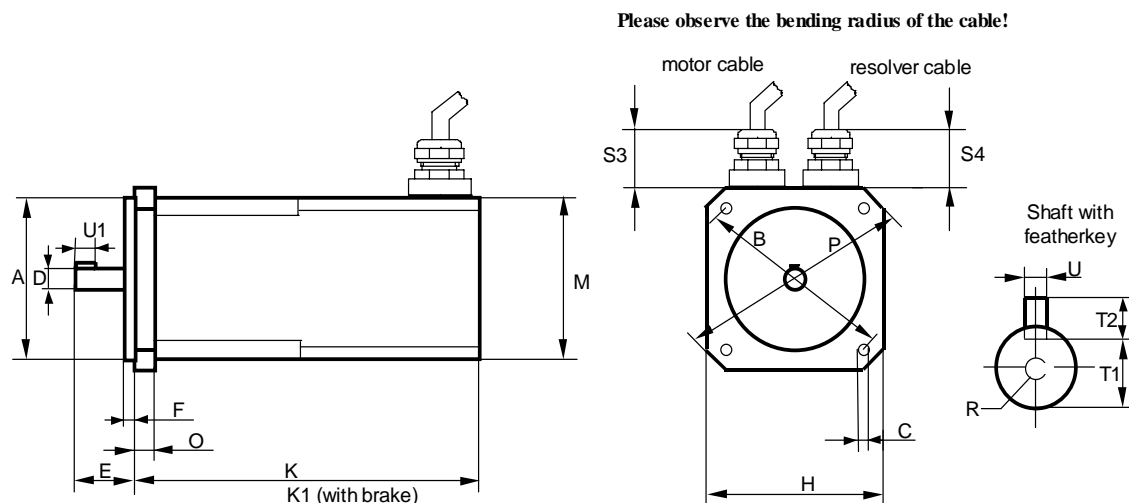

Dimensions like standard design, except:

AC Mn size	S3		S4		Motor connection via PG coupling	Resolver connection via PG coupling	Comments
	Design Skintop	EMC	Design Skintop	EMC			
0	-	-	-	-	-	-	-
1	28	21	25	20	13,5	9	-
2	28	21	25	20	13,5	9	-
3	-	-	-	-	-	-	-

Attention with S3 and S4:

Observe the bending radius of the cables !

4.2.2 Motor with pulse encoder attachment preparation for incremental encoder DG60 resp. ROD426 for motor size 1 - 3

Dimension drawing: on request !

5 Connector assignment

5.1 Motor connection for standard design Pin assignment for SSD Drives motors, size 0...3

5.1.1 SSD Drives-servo drives 635/DER / 637/D6R

(and old products FRR AC S, ESR AC S)

in the SSD Drives Rack

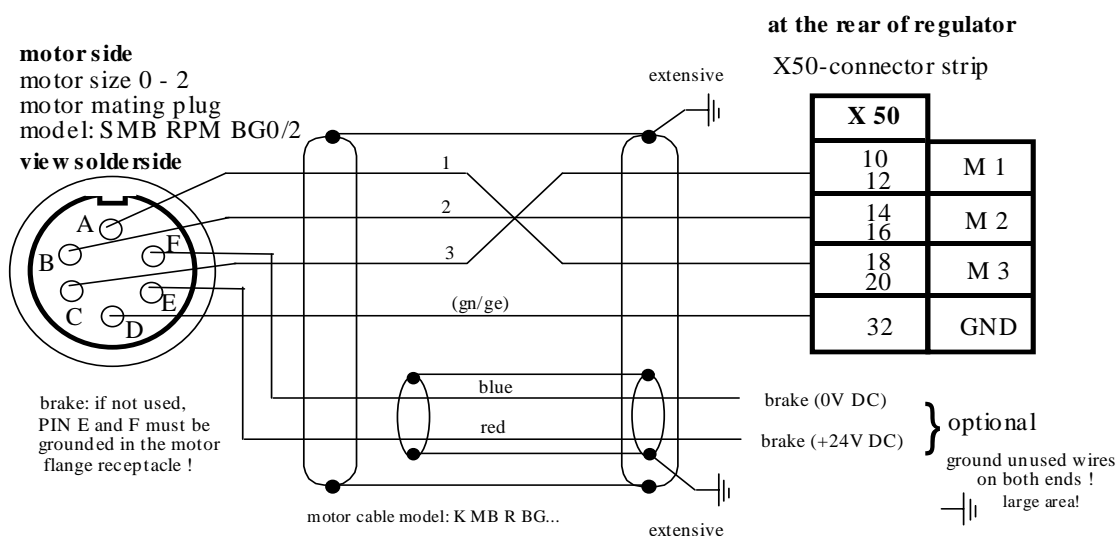

Motor-line-shield: on both ends, extensively connected!

motor size 3
motor mating plug
model: SMB R BG 3
view solderside

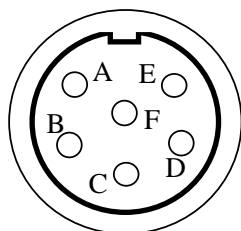

connections see above !

The mating plugs are not included in the standard delivery!



Connector assignment

Motor connection for standard design Pin assignment for SSD Drives motors, size 0...3

5.1.2 SSD Drives-servo drive 635/K DER in the compact enclosure

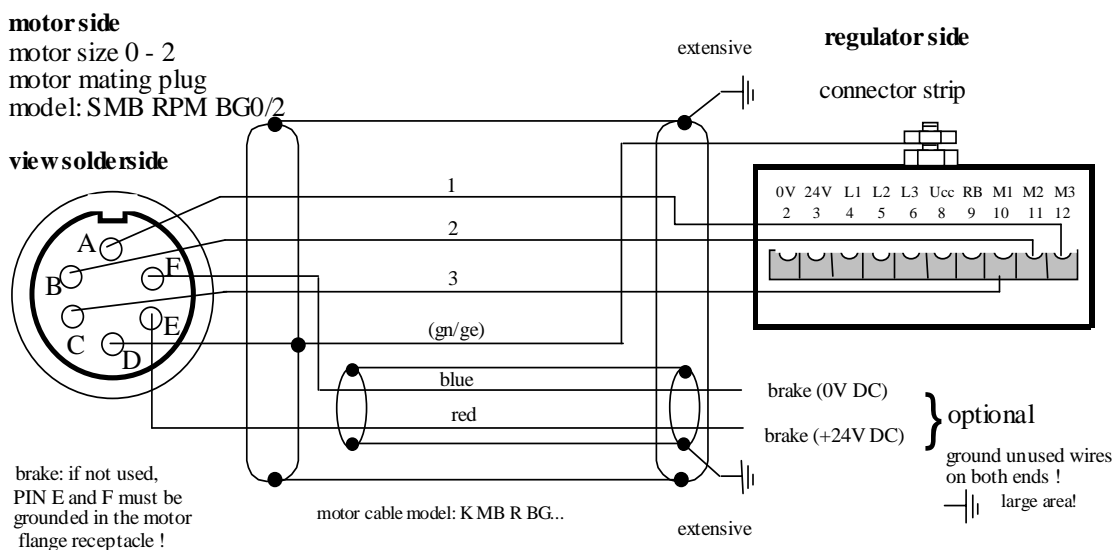

Motor-line-shield: on both ends, extensively connected!

motor size 3
motor mating plug
model: SMB R BG 3

view solderside

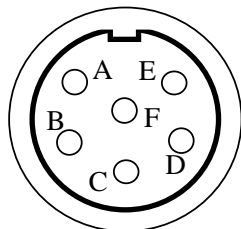

connections see above !

The mating plugs are not included in the standard delivery!

Connector assignment

Motor connection for standard design Pin assignment for SSD Drives motors, size 0...3

5.1.3 SSD Drives-servo drive 637/K D6R in the compact enclosure

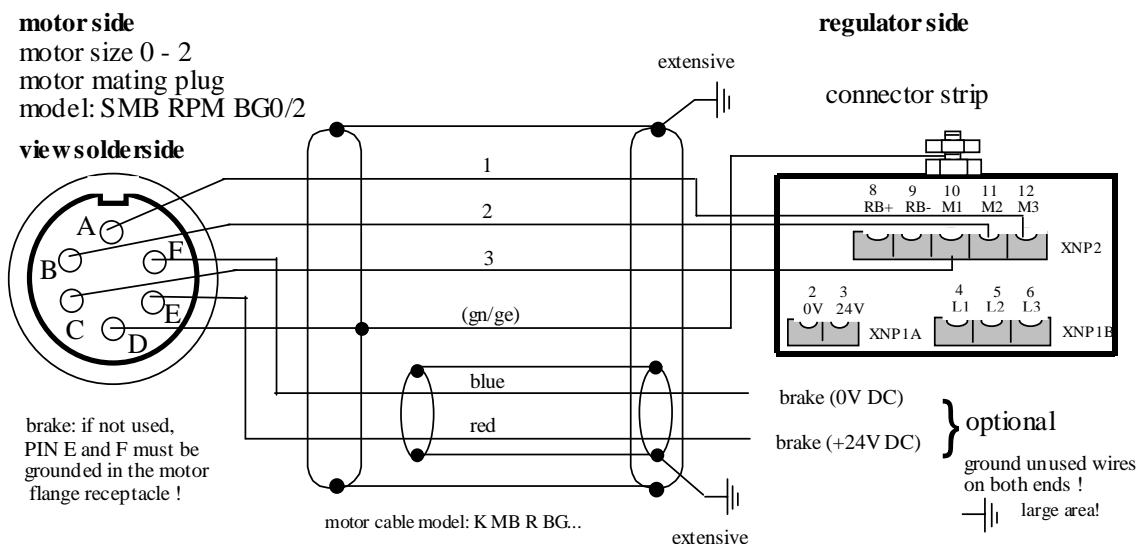

Motor-line-shield: on both ends, extensively connected!

motor size 3
motor mating plug
model: SMB R BG 3

view solder side

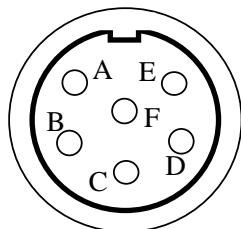

connections see above !

The mating plugs are not included in the standard delivery!

Connector assignment

Motor connection for standard design Pin assignment for SSD Drives motors, size 0...3

5.1.4 SSD Drives-servo drive (old product FRR AC S) in the compact enclosure

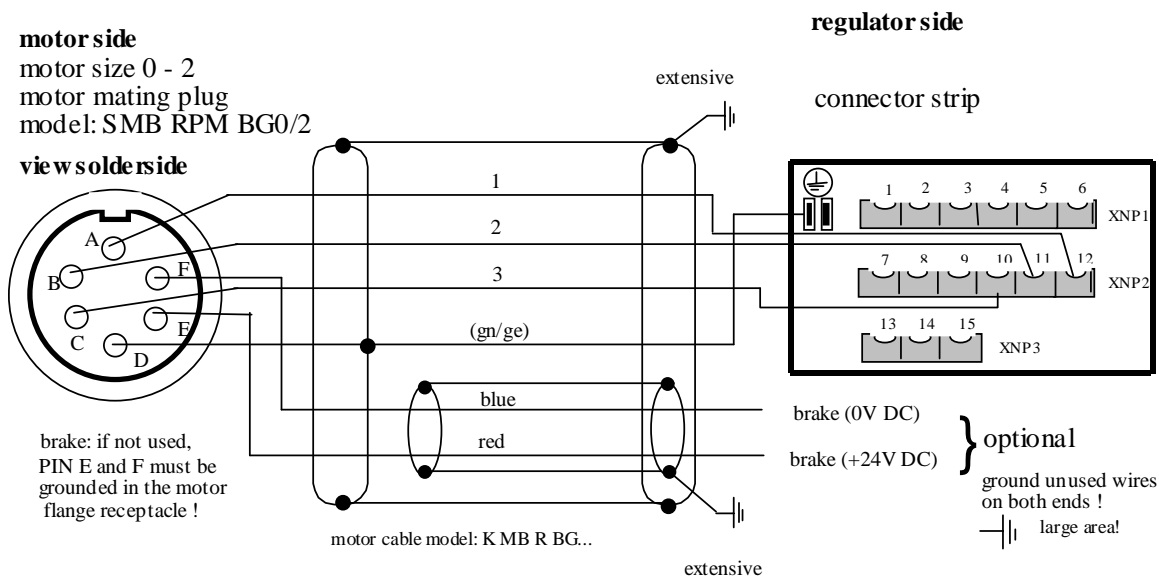

Motor-line-shield: on both ends, extensively connected!

motor size 3
motor mating plug
model: SMB R BG 3

view solder side

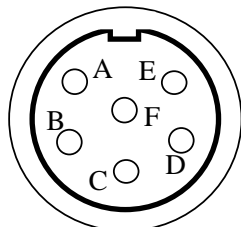

connections see above !

The mating plugs are not included in the standard delivery!

Connector assignment

5.2 Motor connection for special design (Connections via PG with cable ends) Pin assignment for SSD Drives motors, size 0...3

5.2.1 SSD Drives-servo drives 635/DER / 637/D6R

(old products ESR AC S, FRR AC S)

in the SSD Drives Rack

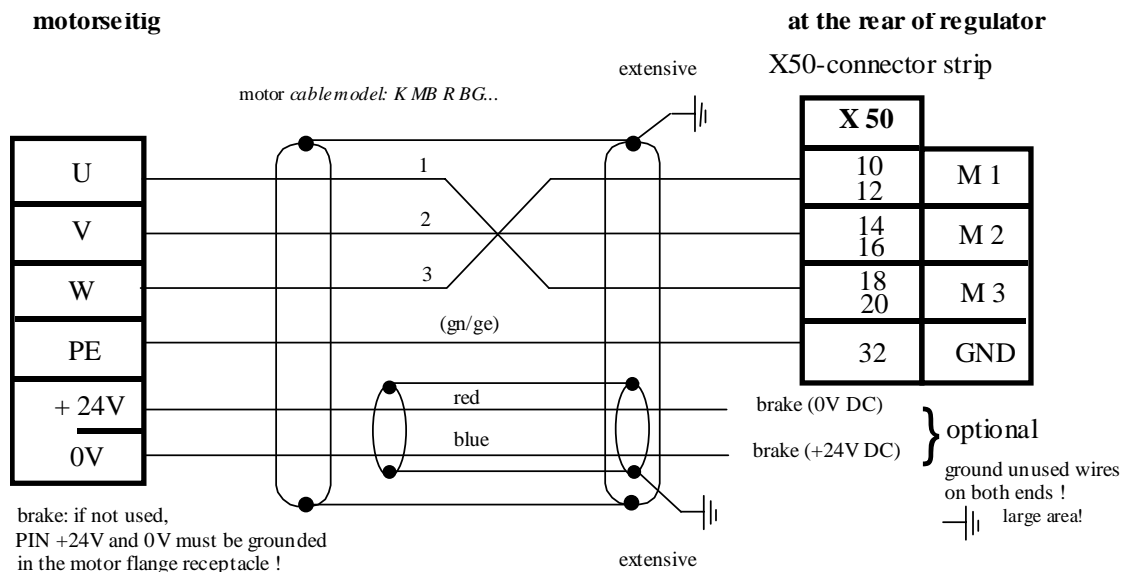

5.2.2 SSD Drives-servo drive 635/K DER in the compact- or low cost enclosure

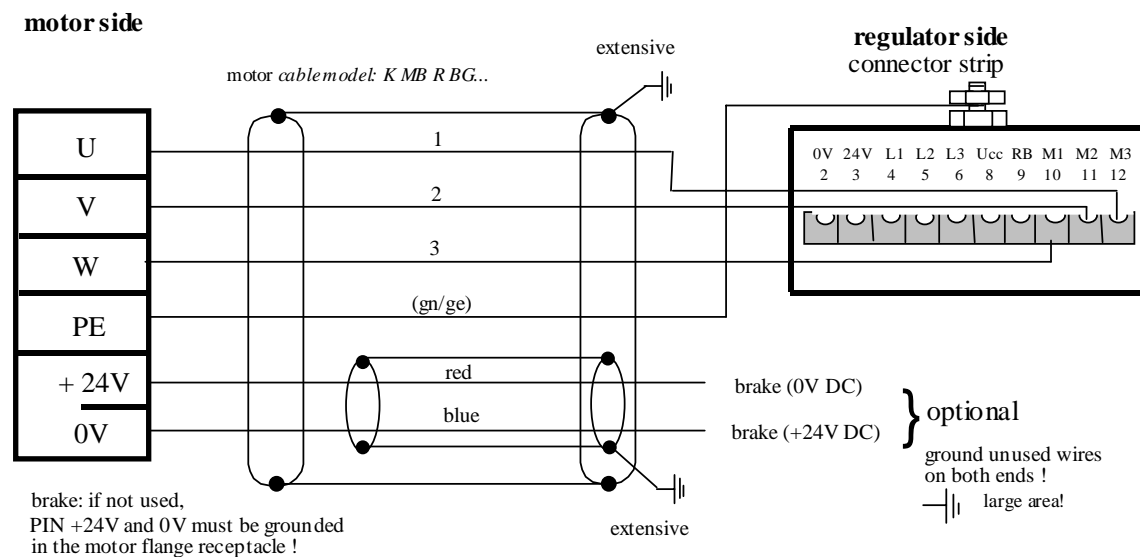

Motor-line-shield: on both ends, extensively connected!

Connector assignment

Motor connection for special design (Connections via PG with cable ends)
Pin assignment for SSD Drives motors, size 0...3 (only motor size 0 at the moment)

5.2.3 SSD Drives-servo drive 637/K D6R in thea compact enclosure

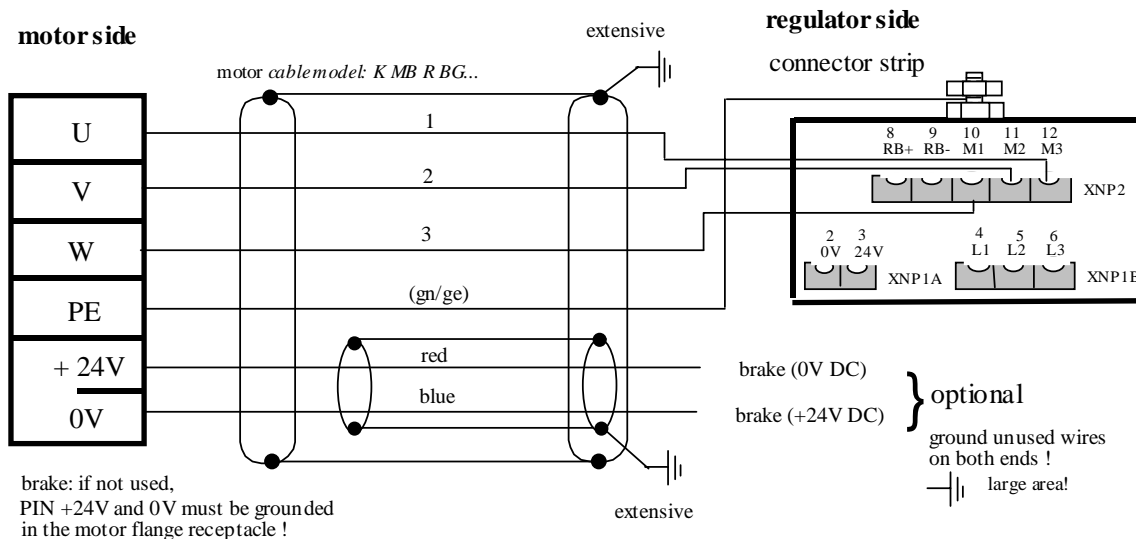

5.2.4 SSD Drives-servo drive (old product FRR AC S) in the compact enclosure

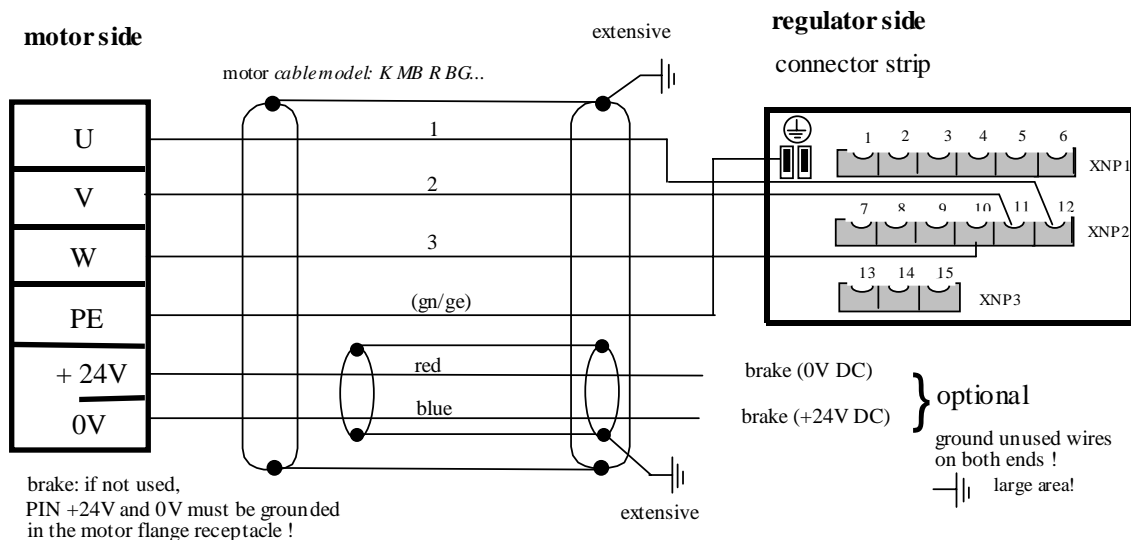

Motor-line-shield: on both ends, extensively connected!

Connector assignment

5.3 Resolver connection

for SSD Drives motor size 0...3 and on servo drive 631/635 and 637/637+

motor side

resolver mating plugs

Typ :SIR SUB D 09 male

controller side

X 30 mating plugs

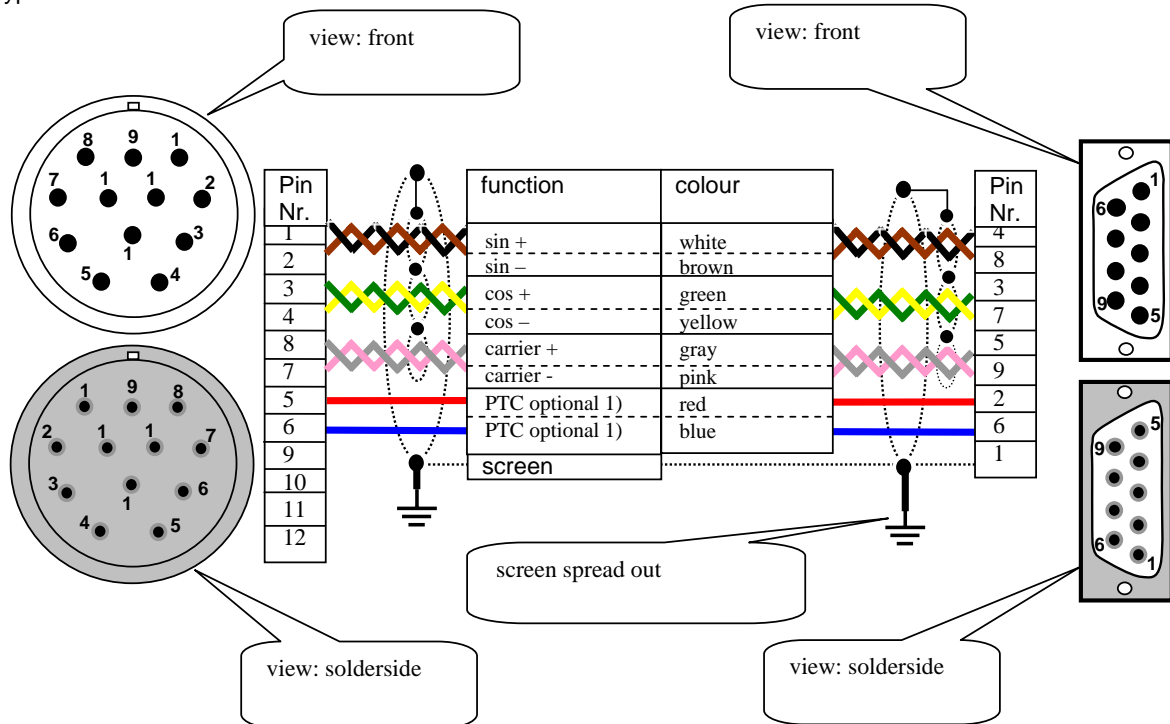

1) **Attention ! Security and insulation:**

The temperature sensor in the motor winding must be insulated for secure division (PELV).

Otherwise, the insulation class of the drive becomes reduced or the effort of an additional galvanic separation is required.

The mating plugs are not included in the standard delivery

Connector assignment

Resolver connection

5.3.1 Special design with the cables PG-coupling

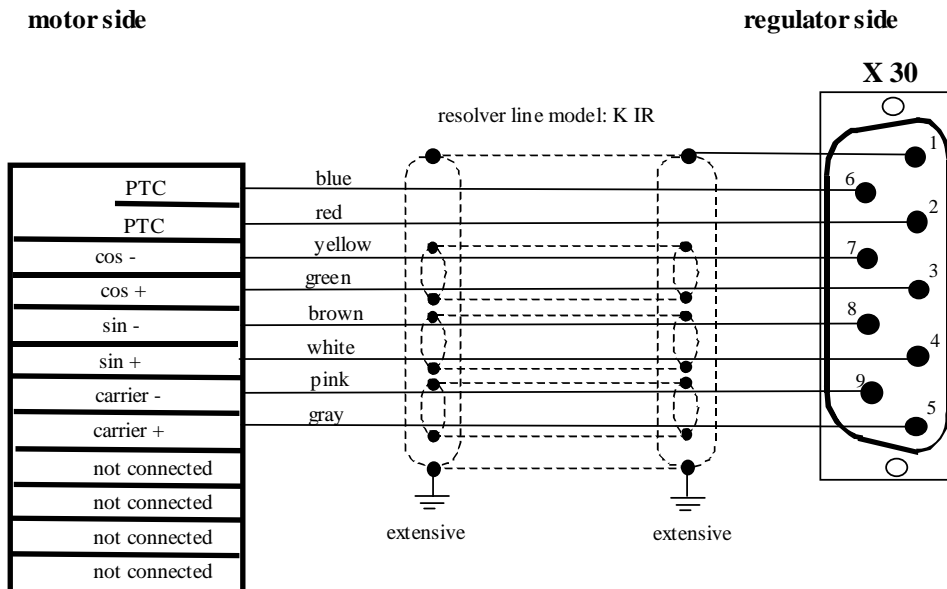

Connector assignment

5.4 Cabling instructions

Important rules when operating servo regulators and servomotors:

1. A radio interference suppression level cannot be maintained without an interference suppression filter at the line input. Moreover, line filter increase the immunity of the system to interference.
2. The cable between the power electronics and the motor must be shielded as YCY. A SY shield is not suitable. The shield support for the power cable (motor cable) must be on both ends. We recommend using SSD Drives motor cables K M BG xx – B!
3. Metal parts in the switching cabinet must be connected with each other having large areas of contact and must carry high frequencies very well. Avoid anodized, yellow-passivized and painted surfaces which can have very high resistance values based on the frequency! Make sure that the metals lie close together in the chemical circuit voltage class! Use the good conductivity and the large surface of the galvanized mounting plate as earth potential!
4. Relays, contactors and solenoid valves build into the same circuit must be connected with spark-suppressing combinations or components limiting over voltage, respectively. This applies also if these parts are not mounted in the same cabinet as the servo regulator.
5. The shield for the analog signal lines must be installed on one end and, if possible, in the switching cabinet. Ensure a connection which provides extensive contact and which is low-resistant! The shield for the digital signal lines must be installed on both ends, must have extensive contact and must be low resistance. An additional equalizer is to be laid parallel when there are potential differences. It is necessary to use plugs with metal enclosures with separable connections.
6. Avoid unnecessary extra loops on all connecting cables. All measures regarding filtering and shielding can be short circuited on them with high frequency. Connect unused litz wires in cables on both ends to the equipment ground conductor.
7. Unshielded cables of a circuit, the conductors going out and returning, should be twisted due to symmetrical interferences.
8. Separate physically "live" and "dead" wires even in the planning phase. Give special attention to the motor cables. The area of the common terminal strip-line input and motor output is especially endangered.
9. Relays, contactors and solenoid valves. The cables should be laid in the switching cabinet as close as possible to the ground; wires hanging freely in the air are preferred EMC victims as well as active and passive aeriels.
10. When operating with more than one line component in a common network, EMC problems are to be expected. From the start, the installation planer must integrate in his concept high frequency emitted interference as well as the electromagnetic susceptibility of the components to one another and take measures against it.
11. It is absolutely necessary to run cable shields completely up to the connectors. The connection of cable shields to ground must be in the near field of the servo regulator (10 - 50 cm). Sensitive measuring leads should be removed as far as possible from this area; this applies also when they are shielded!
12. It is mandatory to run the motor cables in a separate cable channel and to lay flexible cable shielding also when these are shielded. This channel must be separated by at least 30 - 40 cm from the channel for the signal lines.



Connector assignment

5.5 Plug designation

5.5.1 Mating plugs for motor- and brake connections

Size	Plug designation
0 - 2	SMB RPM BG 0/2
3	SMB R BG 3

5.5.2 Mating plugs for resolver- and thermal connection

Size	Plug designation
all	SIR

6 Technical data of the holding brake optional

holding brake	motor size	holding torque	max. current	moment of inertia	weight
Model:	BG	M_{BrH}	I_{max}	J_{Br}	m_{Br}
	(-)	(Nm)	(A)	(kg cm ²)	(g)
BR M BG0	0	1,2	0,37	0,01	190
BR M BG1	1	3,2	0,42	0,3	445
BR M BG2	2	6,0	0,55	0,63	700
BR M BG3	3	12,0	0,75	2,1	1280

Supply voltage: $U_S = 24 \text{ V DC}$, $\pm 10\%$ acc. VDE 0580

Holding brakes are integrated on A- side; therefore the motor length is changed, see dimension K1 !

The inserted brake is not characterized for the general slowing-down the drives, but is merely a standstill and/or holding brake.

Therefore, it must become guaranteed by the customer that the drive stands, before that brake comes in. Should that brake not only become employed in the case of standing drives, so it's generally the wear and therefore the holding torque of the brake depending on:

- the speed of the drive with witch the brake will be switched
- the load moment of inertia on the drive
- environmental conditions as temperature, and so forth.
- the number of braking and so forth

7 Shaft loads

7.1 radial shaft load

7.1.1 Representation of the definition

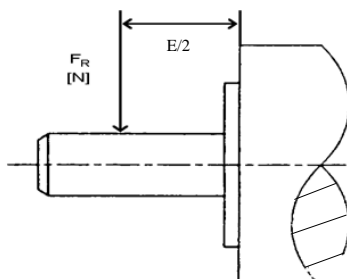

7.1.2 technical dates of the max. radial shaft load FR (N)

Motor size	rated speed	maximum radial shaft load
(-)	MN (1/min)	FR (N)
0	4000	220
1	4000	250
2	4000	300
3	4000	570

7.2 axial shaft load

7.2.1 Representation of the definition

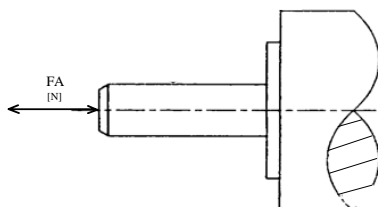

7.2.2 technical dates of the max. axial shaft load FA (N)

Motor size	rated speed	maximum axial shaft load
(-)	MN (1/min)	FR (N)
0	4000	80
1	4000	90
2	4000	100
3	4000	200

The specifications refers to 20000 hours of operation !

7.3 Use Ball bearing type

Motor-Size	Ball bearing type	
	A-seitig	B-seitig
0	6001	6001
1	6003	6001
2	6004	6002
3	6005	6003

8 Nominal power dependence of the SSD Drives AC servo motors concerning the installation altitude

8.1 Short description

When selecting an adequate motor the following is to be considered:

Workload (power), operating mode, starting, braking and by-passing processes, additional moment of inertia, moment course of the operating machine, speed control if necessary, net ratios, coolant temperature, installation altitude etc.

The nominal power is the power which is mechanically available at the shaft, if the installation site is not situated above 1000 m MSL, the air temperature does not exceed 40° C, and the net ratios are normal.

With deviating conditions concerning installation altitude and air temperature, the permissible power must be corrected corresponding to the following picture.

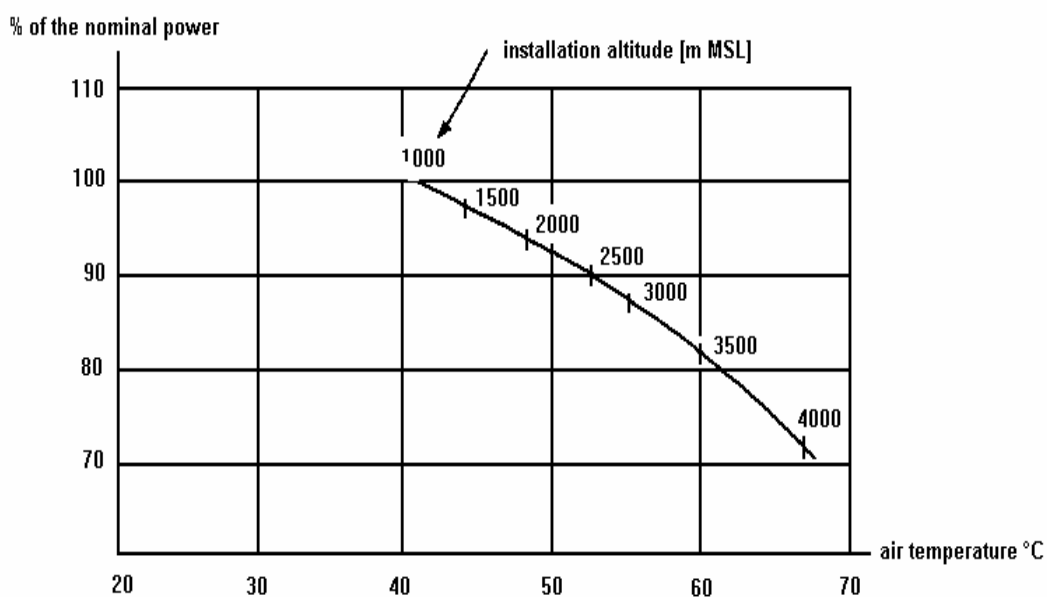

Check the air temperature and the installation altitude separately. Should there be different air temperatures and installation altitude at the same time, the factors for the permissible power must be multiplied.



9 Modification Record

Version	Modification	Chapter	Date	Name	Comment
V16.04EH99	new chapter resolver connection text addition text modification new chapter	4.2.2 5.3.1 6 7 9	03.02.1999	K. Stadler	Documentation in ET - design
V17.16EH99	text addition technical data new chapter text addition	1.3 3 3.1 6	20.04.1999	K. Stadler	
V18.43EH99	technical data dimensions technical data	2 4.1.1 5.3.1	27.10.1999	Iris Worm	
V1901	Separation German / English	all	18.01.2001	N. Dreilich	
V2005	SSD Drives	all	08.04.2005	N. Dreilich	Logos

AUSTRALIA
Eurotherm Pty Ltd
Unit 1
20-22 Foundry Road
Seven Hills
New South Wales 2147
Tel: +61 2 9838 0099
Fax: +61 2 9838 9288

CANADA
SSD Drives Inc
880 Laurentian Drive
Burlington
Ontario
Canada, L7N 3V6
Tel: +1 905 333-7787
Fax: +1 905 632-0107

CHINA
Eurotherm Pty Ltd
Apt. 1805, 8 Building Hua Wei Li
Chao Yang District,
Beijing 100021
Tel: +86 10 87785520
Fax: +86 10 87790272

DENEMARK
SSD Drives
Enghavevej 11
DK-7100 Vejle
Tel: +45 70 201311
Fax: +45 70 201312

FRANCE
SSD Drives SAS
15 Avenue de Norvège
Villebon sur Yvette
91953 Courtaboeuf Cedex / Paris
Tel: +33 1 69 185151
Fax: +33 1 69 185159

GERMANY
SSD DRIVES GmbH
Von-Humboldt-Straße 10
64646 Heppenheim
Tel: +49 6252 7982-00
Fax: +49 6252 7982-05

HONG KONG
Eurotherm Ltd
Unit D
18/F Gee Chang Hong Centre
65 Wong Chuk Hang Road
Aberdeen
Tel: +852 2873 3826
Fax: +852 2870 0148

INDIA
Eurotherm DEL India Ltd
152, Developed Plots Estate
Perungudi
Chennai 600 096, India
Tel: +91 44 2496 1129
Fax: +91 44 2496 1831

IRELAND
SSD Drives
2004/4 Orchard Ave
Citywest Business Park
Naas Rd, Dublin 24
Tel: +353 1 4691800
Fax: +353 1 4691300

ITALY
SSD Drives SpA
Via Gran Sasso 9
20030 Lentate Sul Seveso
Milano
Tel: +39 0362 557308
Fax: +39 0362 557312

JAPAN
PTI Japan Ltd
7F, Yurakucho Building
10-1, Yuakucho 1-Chome
Chiyoda-ku, Tokyo 100-0006
Tel: +81 3 32132111
Fax: +81 3 32131900

KOREA
SSD Korea Co., Ltd.
1308, Daeryung Techno Town
8th Bldg., 481-11 Gasan-Dong,
Geumcheon-Gu,
Seoul 153-803
Tel: +82 2 2163 6677
Fax: +82 2 2163 8982

NETHERLANDS
Eurotherm BV
Genielaan 4
2404CH
Alphen aan den Rijn
Tel: +31 172 411 752
Fax: +31 172 417 260

Poland
OBR-USN
ul. Batorego 107
PL 87-100 Torun
Tel: +48 56 62340-21
Fax: +48 56 62344-25

Romania
Servosisteme SRL
Sibiu 17
061535 Bukarest
Tel: +40 723348999
Fax: +40 214131290

SCHWEDEN
SSD Drives AB
Montörögatan 7
S-30260 Halmstad
Tel: +46 35 177300
Fax: +46 35 108407

SPAN
Eurotherm Espana S.A.
Pol. Ind. Alcobendas
C/ La Granja, 74
28108 Madrid
Tel: +34 91 661 60 01
Fax: +34 91 661 90 93

SWITZERLAND
Indur Antriebstechnik AG
Margarethenstraße 87
CH 4008 Basel
Tel: +41 61 27929-00
Fax: +41 61 27929-10

United Kingdom
SSD Drives Ltd
New Courtwick Lane
Littlehampton
West Sussex BN17 7RZ
Tel: +44 1903 737000
Fax: +44 1903 737100

U.S.A
SSD Drives Inc.
9225 Forsyth Park Drive
Charlotte
North Carolina 28273-3884
Tel: +1 704 588 3246
Fax: +1 704 588 3249

Local availability and service support also in:

Argentina · Austria · Bangladesh · Brazil · Chile · Colombia · Costa Rica · Cyprus · Czech Republic · Ecuador · Greece · Hungary · Indonesia · Iceland · Israel · Kuwait · Lithuania · Malaysia · Morocco · Mexico · New Zealand · Nigeria · Peru · Philippines · Portugal · Saudi Arabia · Singapore · Slovenia · Sri Lanka · South Africa · Taiwan · Thailand · Turkey · United Arab Emirates · Vietnam

SSD Drives GmbH

Head Office

Von-Humboldt-Straße 10, D-64646 Heppenheim
Telefon +49 (0)6252 7982-00, Fax +49 (0)6252 7982-05

Plant Servosystems

Im Sand 14, D-76669 Bad Schönborn
Telefon +49 (0)7253 9404-0, Fax +49 (0)7253 9404-99

www.SSDdrives.com

ssd@ssddrives.de