



# GENERAL CATALOGUE

Solenoid Valves for Fluid Control



## Who we are?

The Fluid Control Solutions Europe (FCSE) Business Unit is part of the Fluid and Climate Controls Division Europe (FCCE) of Parker Hannifin, the global leader in Motion and Control Technologies. FCSE core competences are the development and manufacturing of an extremely diverse range of fluid control products, including solenoid valves and pressure regulators.

## Where we are?

Our European headquarters are located in Gessate (Milan-Italy), this is also where our R&D, Marketing, Application Support and Product Management functions are located. Our Products are mainly manufactured in Gessate (Milan - Italy). The Parker Sales Companies and comprehensive distribution network support you, wherever you are.

## History

Parker FCSE has been a leading player in the manufacturing and development of solenoid valve technologies for over 60 years, with continuous research and development bringing innovative solutions to the marketplace, for example leading the way in the utilisation of synthetic ruby for critical water applications or the unsurpassed reliability and precision of our pressure regulators. The expertise accumulated and developed through the years is evident in the superior quality of FCSE solutions.

## Markets

Our products and solutions are typically designed for markets including Industrial Equipment, Industrial Automation, Mobile, Transportation, Life Sciences, Beverage dispensing and for Fluid and Process Control.

## Benefits

The modular concept of our products, having separate solenoid valves and electrical parts, provides the customer with increased flexibility by allowing numerous combinations. This additional flexibility can enable distributors to greater reduce valve inventory levels, whilst retaining the same number of capabilities. Parker also has unrivalled experience in developing customised product solutions complying with the highest technical, environmental, energy and service life requirements.



### WARNING - USER RESPONSIBILITY

**FAILURE OR IMPROPER SELECTION OR IMPROPER USE OF THE PRODUCTS DESCRIBED HEREIN OR RELATED ITEMS CAN CAUSE DEATH, PERSONAL INJURY AND PROPERTY DAMAGE.**

- This document and other information from Parker-Hannifin Corporation, its subsidiaries and authorized distributors provide product or system options for further investigation by users having technical expertise.
- The user, through its own analysis and testing, is solely responsible for making the final selection of the system and components and assuring that all performance, endurance, maintenance, safety and warning requirements of the application are met. The user must analyze all aspects of the application, follow applicable industry standards, and follow the information concerning the product in the current product catalog and in any other materials provided from Parker or its subsidiaries or authorized distributors.
- To the extent that Parker or its subsidiaries or authorized distributors provide component or system options based upon data or specifications provided by the user, the user is responsible for determining that such data and specifications are suitable and sufficient for all applications and reasonably foreseeable uses of the components or systems.



# ORGANIZATION OVERVIEW



**FCSE HEADQUARTER - GESSATE (MI) - ITALY**

# GENERAL CATALOGUE FCSE

## TABLE OF CONTENT

### INTRODUCTION

A complete range of solenoid valves.....	06
A modular concept.....	08
ATEX Certification.....	10
World class standards.....	11
How to use this catalogue.....	12
How to select a valve.....	14
How to order.....	16
How to use coil groups.....	18

### 2 WAY VALVES

Valves for dry or lubricated air, neutral gases and liquids.....	21
Valves for water and neutral liquids.....	61
Anti water hammer valves.....	89
Hot water and steam valves.....	101
Valves for hydraulic oil and neutral liquids (up to 100 bar).....	111
High corrosion resistant valves (303 Stainless Steel).....	127
High corrosion resistant valves (316L Stainless Steel).....	143
Oil burner valves.....	155
Fast switching valves.....	167

### 3 WAY VALVES

Valves for dry or lubricated air, neutral gases and liquids.....	171
Valves for hydraulic oil and neutral liquids (up to 75 bar).....	209
High corrosion resistant valves (303 Stainless Steel).....	213
Valves for beverage dispensing - Liquipure®.....	219

### 2 & 3 WAY VALVES FOR TRANSPORTATION

2 way.....	233
3 way.....	239



## 5 WAY DISTRIBUTORS FOR PNEUMATIC APPLICATIONS

5 way pneumatic distributors (Pipe mounting/Sub-base mounting).....	243
---	-----

## 3 & 5 WAY PNEUMATIC DISTRIBUTORS FOR ACTUATION CONTROL

3 & 5 way pneumatic valves for actuator control (Pipe mounting).....	269
3 & 5 way pneumatic valves for actuator control (NAMUR).....	301
316L Stainless Steel 3 & 5 way valves for actuator control (Pipe mounting and NAMUR) .....	343

## ELECTROPNEUMATIC PRESSURE REGULATORS

EPP4 Series - Basic, Comfort , Comfort ATEX Ranges .....	379
--	-----

## COILS, HOUSINGS & ELECTRICAL PARTS

Introduction.....	411
Coils.....	413
Explosion Proof Electrical Parts .....	443
Housings.....	473
Coil Accessories .....	478
Explosive Environments .....	480
Guidance Chart for IS-Barriers .....	490

## TECHNICAL INFORMATION ABOUT SOLENOID VALVES

Technical information about solenoid valves .....	492
---	-----

## APPENDIX

Table of sub-bases for valves .....	513
Table of voltage codes for coils and electrical parts.....	514
Index by Coil Reference .....	518
Index by Coil Group.....	520
Index by Valve reference .....	522
Index for Valves.....	524

# A COMPLETE RANGE OF SOLENOID VALVES FOR FLUID CONTROL

## 2 WAY VALVES

- For dry or lubricated air, neutral gases and liquids
- For water and neutral liquids
- Anti water hammer
- Hot water and steam
- For hydraulic oil and neutral liquids (Max. 100 bar)
- High corrosion resistant (303 Stainless Steel) (316L Stainless Steel)
- Oil burner
- Fast switching
- Liquipure® for beverage dispensing



## 3 WAY VALVES

- For dry or lubricated air
- For hydraulic oil and neutral liquids (Max. 75 bar)
- High corrosion resistant (303 Stainless Steel)
- Liquipure® for beverage dispensing

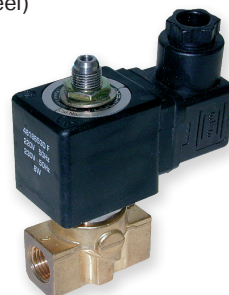

## 2 & 3 WAY VALVES FOR TRANSPORTATION

- 2 way- direct and piloted
- 3 way- direct operated



## 3&5 WAY DISTRIBUTORS FOR PNEUMATIC APPLICATIONS

- Pipe mounted/ Sub-base mounting



## 3 & 5 WAY PNEUMATIC DISTRIBUTORS FOR ACTUATION CONTROL

- Pipe mounted
- NAMUR interface
- 316L Stainless Steel (Pipe mounted and with NAMUR interface)



## COILS & ELECTRICAL PARTS

- Coils
- Housings
- Explosion-Proof Electrical Parts



## EPP4 SERIES ELECTROPNEUMATIC PRESSURE REGULATORS

- Basic
- Comfort
- Comfort ATEX



## A MODULAR CONCEPT FOR EVERY APPLICATION

CHOOSE BETWEEN:

### Actuation Modes

- Direct Operated
- Magnalift
- Pilot Operated
- Manual Reset
- Externally Operated

### Material Types

- Brass
- 303 Stainless St.
- 316L Stainless St.
- Anodized Aluminium
- Zinc Alloy
- POM

### Mounting Solutions

- Pipe
- Sub-base
- NAMUR
- Banjo
- CETOP
- ISO

### Control Functions

- Normally Closed
- Normally Open
- Universal
- Control by Electric Impulse
- Dual Solenoids
- PWM

### Internal Design

- Piston
- Poppet
- Diaphragm
- Spool

### Seals

- FKM
- NBR
- EPDM
- Ruby
- PUR
- PCTFE...

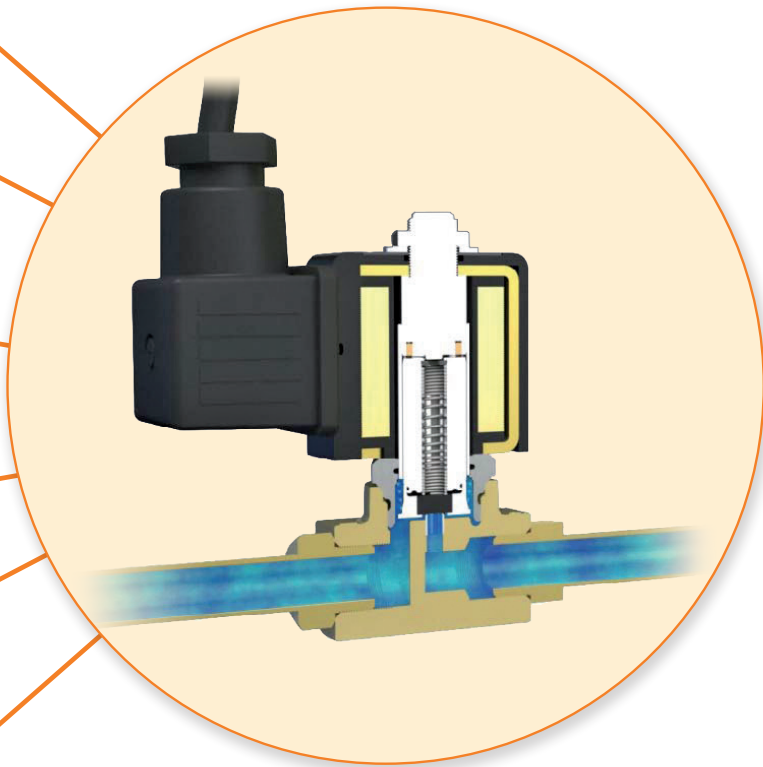

## ATEX CERTIFICATION



### ELECTRICAL PART ATEX CERTIFICATION

A selection of electrical parts conform to the terms of the 2014/34/EU directive and are made for potentially explosive environments - zone 0/20, 1/21 and 2/22.

Within the coil section, the presence of the ATEX logo  shows that the coil is ATEX approved.



### PRESSURE VESSELS ATEX CERTIFICATION

A selection of pressure vessels conform to the terms of the 2014/34/EU directive specific to non electrical equipment for use within potentially explosive environments - zones 0/20, 1/21 and 2/22.

NAMUR & piped valve ranges now include a marking which indicates mechanical ATEX approval.

Within the valve section, the presence of the ATEX logo  shows that the valve is ATEX approved.

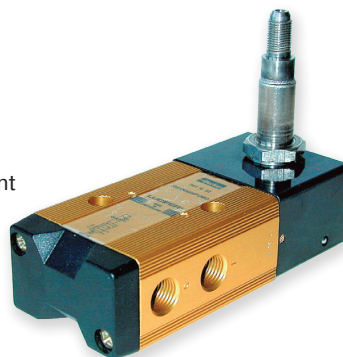

### SOLENOID VALVE CERTIFICATION

When both the electrical and mechanical part are ATEX approved, the solenoid valve can be used in explosive atmospheres.

The solenoid valve can be delivered assembled and tested.

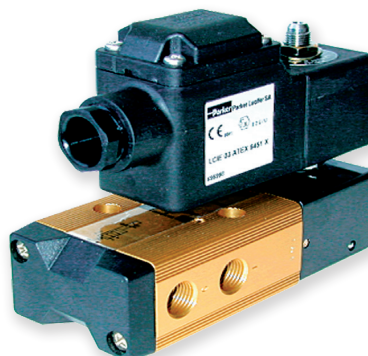

# FCSE IS MEETING WORLD CLASS STANDARDS

## QUALITY STANDARDS:

- ISO 9001
- ISO 14001
- OHSAS 18001
- ISO 45001 : 2018



## CERTIFICATIONS AND APPROVALS:

Our products have been approved and are compliant with the relevant market requirements including:

- CE
- ATEX
- RoHS
- UL
- REACH
- IECEX
- CSA
- DIN-TUV
- AGA
- CCC
- KOSHA
- IMQ
- NSF
- VDE
- JPEX
- UKCA



# HOW TO USE THIS CATALOGUE

This catalogue is a comprehensive list of Parker Solenoid Valves program. It will help to identify appropriate valves and coils and enable the user to generate ordering numbers.

This catalogue is split product range. You will find a summary page at the beginning of each valve section. For ease of use, each valve section is divided by application.

On the first page of each Application section, you will find an overview of the products within and their technical characteristics, to guide you to the relevant page (example below):

## SECTION SUMMARY PAGE

**2 WAY VALVES**

VALVES FOR DRY OR LUBRICATED AIR, NEUTRAL GASES AND LIQUIDS

**2/2**

Actuation	Body	Function	Port Size	Orifice (mm)	Flow Factor (Kv/Cv)	Mounting	Max. Fluid Temp. (°C)	Page Number	Page Count
Direct Operated	Brass/Pipe mounting	Normally Closed	1/8"	1.2 to 3	4.5	70	140	26	32
			1/4"	1.2 to 6	13	100	140	26	32
			3/8"	4 to 6	12	10	120	-	36
	Normally Open	1/2"	8.5 to 11	36	4	120	-	36	36
		1/8"	2.5	2.5	20	140	-	40	40
		1/4"	1.5 to 3	4	40	140	38	40	
Brass/Sub-base mounting	Control by Electric Input	Normally Closed	1/4"	3 to 5	11	20	300	-	40
			5 mm	1.5 to 3	4.5	100	120	-	42
			Normally Open	5 mm	1.5	1.5	20	120	-
MagniFit	Brass/Pipe mounting	Normally Closed	3/8"	13 to 15	65	20	140	46	48
			1/2"	13 to 15	65	20	140	46	48
			3/4"	15 to 20	100	20	140	46	50
			1"	15 to 20	100	20	140	46	50
Pilot Operated	Brass/Pipe mounting	Normally Closed	1/4"	8 to 12	36	40	120	-	56
			3/8"	11 to 13	50	40	120	54	58
			1/2"	11 to 15	60	40	120	54	60
			3/4"	15 to 20	135	40	120	54	62
			1"	18 to 28	270	40	120	54	64
			1 1/2"	40	405	16	120	-	66
			2"	40	540	16	120	-	66
			1/4"	8	36	40	120	-	70
			3/8"	11 to 13	50	40	120	-	68
			1/2"	13 to 15	60	40	140	68	70
		Normally Open	3/8"	15 to 20	135	40	120	66	72
			1"	25 to 40	420	16	120	68	72
			1 1/4"	28	270	16	120	-	72
			1 1/2"	40	420	12	300	-	72
			2"	40	540	12	120	-	72
			1/4"	12	36	12	300	-	74
			3/8"	12	45	12	300	-	74
			1/2"	12	50	12	300	-	74
			3/4"	18	100	12	300	-	74
			1"	18	110	12	300	-	74
Brass/Sub-base mounting	Control by Electric Input	Normally Closed	14 mm	14	45	40	140	-	74
			Normally Open	14 mm	14	45	40	120	-

**Product range**

**Application**

**Number of ways / positions**

**Actuation**

**Applicable Fluids**

**Actuation, body and function**

**Body**

**Mounting**

**Function**

**Technical features**

**Related page**

For further technical information regarding Actuation, Body and Function, please refer to the technical information section at the end of the catalogue.



Applicable Approvals within this page

Quick selection table with Min/Max values for all valves on the page

## SECTION PRODUCT PAGE

**2 WAY VALVES**

**2/2 VALVES FOR HYDRAULIC OIL AND NEUTRAL LIQUIDS (UP TO 100 BAR)**

**PILOT OPERATED**

**BRASS PIPE MOUNTING**

**NORMALLY CLOSED**

Port size	Order ID	Flow factors	Kv (l/min)	Cv (gpm)	Qn (l/min)	Operating Pressure (bar)	Min. Seal	Max. Seal	Fluid Temp. (°C)	Valve Seat	Housing Mat.	Coil Mat.	AC/DC	Coil Group	Draw. No.	
1/4"	8 36 2.16	1600	0.3	40	25	-10	100	NBR		E321911	2965	481885	9	9	2.0	3523
	8 36 2.16	1600	0.3	40	25	-10	100	NBR		E321911	4270	481885	9	9	2.0	3523
	8 36 2.16	1600	0.3	40	25	-10	100	NBR		E321911	4270	482695	14	14	2.0	3523
1/2"	8 36 2.16	-	0.3	40	25	-10	100	FPM		E321921	2965	481885	9	9	2.0	3523
	8 36 2.16	-	0.3	40	30	-10	120	FPM		E321921	4270	481885	9	9	2.0	3523
	8 36 2.16	-	0.3	40	30	-10	140	FPM		E321921	4270	482695	14	14	2.0	3523
3/8"	11 50 3	2800	0.3	40	25	-10	100	NBR		E321913	2965	481885	9	9	2.0	3524
	11 50 3	2800	0.3	40	30	-10	100	NBR		E321913	4270	481885	9	9	2.0	3524
	11 50 3	2800	0.3	40	30	-10	120	FPM		E321923	2965	481885	9	9	2.0	3524
	11 50 3	2800	0.3	40	30	-10	140	FPM		E321923	4270	481885	14	14	2.0	3524
	11 36 2.16	-	0.2	30	3	-10	100	Ruby		E321933	2965	483610	9	-	2.0	3429
	11 36 2.16	-	0.2	30	4	-10	140	Ruby		E321933	4270	483610	9	-	2.0	3429

**Notes:**  
 1 Minimum pressure differential: 0.3 bar for opening and 0 bar for closing  
 2 Pilot seat disc in synthetic Ruby

**2 WAY VALVES**

For this page	Port Size	Order ID	Kv (l/min)	MOPP (bar)	Fluid Temp (°C)
From	1/4"	8	36	3	-10
To	3/8"	11	50	40	140

Ordering information

ISO 1219 Symbol

A choice of Coil Groups compatible with the selected valve.

Dimensional 2D\* and 3D drawings

\* 2D drawing shown always corresponds to the standard coil.



## HOW TO SELECT A VALVE

Once you are in the selected range **1** and application **2** The table is designed to help you navigate to the products matching your criteria.

First decide the actuation **3**, then move across the table selecting your body material **4**, function **5** and technical requirements **6**.

After you have found products fitting within your specification, please go to the corresponding page number in the final column **7**, here you will find a selection of products that match your criteria.

**1** SELECT PRODUCT FAMILY

**2** SELECT APPLICATION

**3** SELECT ACTUATION

**4** SELECT BODY

**5** SELECT FUNCTION

**6** SELECT TECHNICAL DATA

**7** SELECT CORRESPONDING PAGE

1

2 WAY VALVES

VALVES FOR DRY OR LUBRICATED AIR, NEUTRAL GASES AND LIQUIDS

2



2/2

Actuation	Body	Function	Port Size	Orifice (mm)	Flow Factor Kv(l/min)	MOPD (bar)	Max Fluid Temp. (°C)	Page Parker Valves	Page Parker JIC/ISO Valves			
Direct Operated	Brass/Pipe mounting	Normally Closed	1/8"	1.2 to 3	4.5	70	140	28	32			
			1/4"	1.2 to 5	13	100	140	30	32			
			3/8"	4 to 6	12	10	120	-	36			
			1/2"	8.5 to 11	36	4	120	-	36			
			1/8"	2.5	3.5	30	140	-	40			
	Magnalift	Brass/Pipe mounting	Normally Closed	1/4"	1.5 to 3	4	40	140	38	40		
				Control by Electric Impulse	1/4"	3 to 5	11	20	100	-	40	
				Brass/Sub-base mounting	Normally Closed	5 mm	1.5 to 3	4.5	100	130	-	42
					Normally Open	5 mm	1.5	1.5	20	120	-	44
				Brass/Pipe mounting	Normally Closed	3/8"	13 to 15	65	20	140	46	48
1/2"		13 to 15	65			20	140	46	48			
3/4"		15 to 20	100			20	140	46	50			
1"		15 to 25	170			20	140	46	52			
Pilot Operated		Brass/Pipe mounting	Normally Closed			1/4"	8 to 12	40	40	120	-	54
				3/8"	11 to 13	50	40	120	54			
	1/2"			11 to 15	60	40	120	54				
	3/4"			15 to 20	135	40	120	54				
	1"			18 to 28	270	16	120	54	64			
	Brass/Sub-base mounting	Normally Open	1 1/2"	40	425	16	120	-	66			
			2"	40	540	16	120	-	66			
			1/4"	8	36	40	140	-	70			
			3/8"	11 to 13	50	40	140	68	70			
			1/2"	13 to 15	60	40	140	68	70			
Control by Electric Impulse	Brass/Pipe mounting	Normally Open	3/4"	15 to 20	135	40	120	68	72			
			1"	25 to 40	420	16	120	68	72			
			1 1/4"	28	270	16	120	-	72			
			1 1/2"	40	420	12	100	-	72			
			2"	40	540	12	120	-	72			
	Brass/Sub-base mounting	Normally Closed	1/4"	12	32	12	100	-	74			
			3/8"	12	45	12	100	-	74			
			1/2"	12	50	12	100	-	74			
			3/4"	18	100	12	100	-	74			
			1"	18	110	12	100	-	74			
Brass/Sub-base mounting	Normally Open	14 mm	14	45	40	140	-	76				
		14 mm	14	46	40	120	-	76				



# HOW TO ORDER PARKER SOLENOID VALVES

## A SOLENOID VALVE IS COMPOSED OF 3 ELEMENTS:

The Valve **1** + Housing **2** + Coil **3**

1. Choose the valve reference
2. Choose the housing
3. Choose the coil

### 1 Choose the Valve Reference

Valve Ref.
121K3206
121K3206
121K3206

### 2 Select the housing depending on the protection level (IP 44 to IP 67 found in the coil section)

Housing Ref.
2995
4270
4270

For a given valve, several coil types are being suggested.

For a wider choice, the selected valve is also compatible with every other coil from the same coil group.

2 WAY VALVES																	
VALVES FOR DRY OR LUBRICATED AIR, NEUTRAL GASES AND LIQUIDS DIRECT OPERATED																	
BRASS PIPE MOUNTING																	
NORMALLY CLOSED																	
Part size	Orifice Ø	Flow factors			Operating Pressure Differential Max(MDPO)		Fluid Temp.		Seat Seal	Parker LUCIFER® Valves			Power		Coil Group	Dwg. No.	
		Kv	Kv	Qn	AC	DC	Min	Max		Valve Ref.	Housing Ref.	Coil Ref.	AC W	DC W			
BSP	mm	mm	in³/min	in³/min	bar	bar	°C	°C									
3/8"	4	7.5	0.45	480	0	10	4	-10	100	FKM	121K3206	2995	481895	8	9	2.0	3551
	4	7.5	0.45	480	0	10	5	-10	120	FKM	121K3206	4270	481000	8	8	2.0	3551
	4	7.5	0.45	480	0	10	10	-10	100	FKM	121K3206	4270	486285	14	14	2.0	3551
	5	11	0.66	750	0	7	2	-10	100	FKM	121K3106	2995	481895	8	9	2.0	3551
	5	11	0.66	750	0	7	2	-10	120	FKM	121K3106	4270	481000	8	8	2.0	3551
	5	11	0.66	750	0	7	5	-10	120	FKM	121K3106	4270	486285	14	14	2.0	3551
1/2"	6	12	0.72	1100	0	5	1.1	-10	100	FKM	121K3306	2995	481895	8	9	2.0/14.2	3551
	6	12	0.72	1100	0	5	1.5	-10	120	FKM	121K3306	4270	481000	8	8	2.0/14.2	3551
	6	12	0.72	1100	0	5	3	-10	120	FKM	121K3306	4270	486285	14	14	2.0/14.2	3551
	8.5	25	1.5	1600	0	1.1	0.5	-10	100	FKM	E121K46	2995	481895	8	9	2.0	3427
	8.5	25	1.5	1600	0	2.2	0.5	-10	120	FKM	E121K46	4270	481000	8	8	2.0	3427
	8.5	25	1.5	1600	0	4	1.2	-10	120	FKM	E121K46	4270	486285	14	14	2.0	3427
1/2"	11	36	2.16	2500	0	0.7	0.3	-10	100	FKM	E121K45	2995	481895	8	9	2.0	3427
	11	36	2.16	2500	0	1.2	0.35	-10	120	FKM	E121K45	4270	481000	8	8	2.0	3427
	11	36	2.16	2500	0	2.5	0.7	-10	120	FKM	E121K45	4270	486285	14	14	2.0	3427

Notes:  
1. Valve compatible with water only up to 40°C  
2. With manual override



Parker coils are available in many different voltages.  
Choose the one you need by putting the voltage code at the end of your ordering number.

### 3 Choose the coil and voltage code

Coil Ref.  
**481865**

VAC/Hz	Code
24/50	A2
48/50	A4
110/50	A5
220-230/50	3D

Valve and coil order example:

1      2      3  
**121K3206**    **2995**    **481865A2**  
 Valve      Housing      Coil and  
 Reference                      Voltage Code

**COILS**

**COIL GROUP**  
**2.0/2.1** COILS FOR DIN PLUG CONNECTION

**COILS 32 mm**

These coils can be mounted with every Parker solenoid valves corresponding to the specified Coil Group.  
See column "Coil Group" within valve pages.  
This is an encapsulated assembly comprising a coil, integral magnetron path and snap-on plug connection.  
The synthetic material encapsulation provides an effective compact housing, offering full protection against dust, oil, water, etc.  
Ease of mounting in confined space - offers shock and corrosion protection - simplifies conversion of existing equipment to other requirements, etc.  
Coils conform to the IEC/ENEC safety standards and complies with European low-voltage directive.



Specification	Standard	Double frequency
Ref. (without DIN plug)	481865	483510
Ref. (with DIN plug)	482723	482635
Coil Group	2.0 / 2.1	
Degree of protection	IP65 according to IEC / EN 60529 standards (with DIN plug).	
Class insulation	F 155°C	
Electrical connection	The coil is connected with a 2 P + E plug according to EN 175301-803 type A	
Ambient temperature	-40°C to +50°C The application is limited also by the temperature range of the valve.	
Elect. Power	DC	9 W
	AC	12 W
P (coil) 20°C	Pa (holding)	9 W
	Attraction cold	26 VA (9 W)
Weight	130 g (without plug)	
	-10% to +10% of the Un	

VAC/Hz	Code	VDC	Code	VAC/Hz	Code
24/50	A2	24	C2	24/50, 24/60	P0
48/50	A4	48	C4	48/50, 48/60	S4
110/50	A5	110	C5	110-115/50, 120/60	S5
220-230/50	3D			220-240/50, 240/60	S6

To Order a Coil choose Coil Ref + Voltage Code, example: 481865 for 24 VDC = **481865C2**  
More voltage possibilities can be found in the table of voltage codes at the end of the coil section.

These coils must be used with suitable housings, see example below.

The coil assembly kit Ref. 2995 corresponds to the "housing" of Lucifer® valve numbering system (Valve - housing - coil/voltage).  
It is composed of a nameplate giving details of the valve type, a round washer and a nut to ensure the fixing between 32 mm coil and the valve.

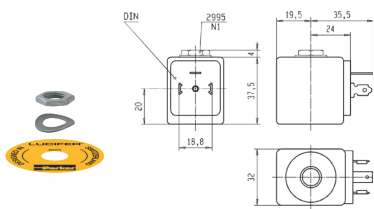

**Parker** 446

**IMPORTANT:** Valve, Housing or Coil shall be ordered separately. In case you would require configured products, please consult your Parker contact or the PH Connect to determine available configurations.

# HOW TO USE COIL GROUPS

## WITHIN A VALVE PAGE

One of Parker's strengths is the modularity, adaptability and flexibility of our products. When you select a solenoid valve, the coils displayed in the table have been chosen as they will fulfill the majority of application requirements.

Valve Ref.	Housing Ref.	Coil Ref.
121K3206	2995	481865
121K3206	4270	481000
121K3206	4270	486265

However, in some specific cases, you will need special features that will lead you to choose another coil.

Groups have been created in order to facilitate the selection of a compatible coil with the chosen valve.

Coil Group
2.0
2.0
2.0

### Example:

The valve 121K3206 is proposed with the coil 481865 but you can also choose any coil from the group 2.0.

**2 WAY VALVES**

**2/2** VALVES FOR DRY OR LUBRICATED AIR, NEUTRAL GASES AND LIQUIDS  
DIRECT OPERATED

**BRASS PIPE MOUNTING**

**NORMALLY CLOSED**

Part size	Orifice Ø	Flow factors			Operating Pressure Differential		Fluid Temp.		Seat Seal	Parker LUCIFER® Valves			Power		Coil Group	Dwg. No.		
		Kv	Kv	Qn	Min	Max	Min	Max		Valve Ref.	Housing Ref.	Coil Ref.	AC W	DC W				
3/8"	4	7.5	0.45	0	10	4	-10	100	FKM	121K3206	2995	481865	8	9	2.0	3551		
	4	7.5	0.45	480	0	10	-10	120	FKM	121K3206	4270	481000	8	8	2.0	3551		
	4	7.5	0.45	480	0	10	10	-10	FKM	121K3206	4270	486265	14	14	2.0	3551		
	5	11	0.66	750	0	7	2	-10	100	FKM	121K3106	2995	481865	8	9	2.0	3551	
	5	11	0.66	750	0	7	2.8	-10	120	FKM	121K3106	4270	481000	8	8	2.0	3551	
	5	11	0.66	750	0	7	5	-10	120	FKM	121K3106	4270	486265	14	14	2.0	3551	
	6	12	0.72	1100	0	5	1.1	-10	100	FKM	121K3306	2995	481865	9	9	2.0/14.2	3551	
	6	12	0.72	1100	0	5	1.5	-10	120	FKM	121K3306	4270	481000	8	8	2.0/14.2	3551	
	6	12	0.72	1100	0	5	3	-10	120	FKM	121K3306	4270	486265	14	14	2.0/14.2	3551	
	1/2"	8.5	25	1.5	1600	0	1.1	0.5	-10	100	FKM	E121K46	2995	481865	8	9	2.0	3427
		8.5	25	1.5	1600	0	2.2	0.5	-10	120	FKM	E121K46	4270	481000	8	8	2.0	3427
		8.5	25	1.5	1600	0	4	1.2	-10	120	FKM	E121K46	4270	486265	14	14	2.0	3427
11		36	2.16	2500	0	0.7	0.3	-10	100	FKM	E121K45	2995	481865	8	9	2.0	3427	
11		36	2.16	2500	0	1.2	0.35	-10	120	FKM	E121K45	4270	481000	8	8	2.0	3427	
11		36	2.16	2500	0	2.5	0.7	-10	120	FKM	E121K45	4270	486265	14	14	2.0	3427	

**Notes:**  
1. Valve compatible with water only up to 40°C  
2. With manual lever

**Parker**

It is also possible to choose the coil first and then select the valve using coil groups.

# HOW TO USE COIL GROUPS

## WITHIN A COIL PAGE

The coil section is at the end of the catalogue and displays the specifications of each coil, along with the reference number, class of insulation, ambient temperature, electrical power and weight.

**2.0 / 2.1**

Example: the valve 121K3206 is proposed with coil 481865 but is also compatible with the 2.0 coil group. This means the coil 482725 is also compatible with the chosen valve as it is within this group.

When referring to the coil section you will find the coil group for each coil. This allows you to discover which other coils are compatible with the valve you have chosen.

COILS

COIL GROUP

2.0/2.1

COILS FOR  
DIN PLUG CONNECTION

**COILS 32 mm**

These coils can be mounted with every Parker solenoid valves corresponding to the specified Coil Group. See column "Coil Group" within valve pages.

This is an encapsulated assembly comprising a coil, integral magnetic iron path and snap-on plug connection.

The synthetic material encapsulation provides an effective compact housing, offering full protection against dust, oil, water, etc. Ease of mounting in confined space - offers shock and corrosion protection - simplifies conversion of existing equipment to other requirements, etc.

Coils conform to the IEC/CENELEC safety standards and complies with European low-voltage directive.

Specification	Standard		Double frequency			
Ref. (without DIN plug)	481865		483510			
Ref. (with DIN plug)	482725		482635			
Coil Group	2.0 / 2.1					
Degree of protection	IP65 according to IEC / EN 60529 standards (with DIN plug).					
Class of insulation	F 155°C					
Electrical connection	The coil is connected with a 2 P + E plug according to EN 175301-803 type A					
Ambient temperature	The application is limited also by the temperature range of the valve. -40°C to +50°C					
Elect. Power	DC	Pa (hot)	9 W	-		
		P (cold) 20°C	12 W	-		
AC	Pa (hot)	8 W	9 W	9 W		
	Attraction cold	26 VA (9 W)		32 VA (10 W)		
Weight	130 g (without plug)					
Voltages "Un"	VAC/Hz	Code	VDC	Code	VAC/Hz	Code
-10% to +10% of the Un	24/50	A2	24	C2	24/50, 24/60	PO
	48/50	A4	48	C4	48/50, 48/60	S4
	110/50	A5	110	C5	110-115/50, 120/60	S5
	220-230/50	S0			220-240/50, 240/60	S6

To Order a Coil choose Coil Ref + Voltage Code, example: 481865 for 24 VDC = 481865C2  
More voltage possibilities can be found in the table of voltage codes at the end of the coil section.

These coils must be used with suitable housings, see example below:

The coil assembly kit Ref. 2995 corresponds to the "housing"

It is composed of a nameplate giving details of the valve type, a round washer and a nut to ensure the fixing between 32 mm coil and the valve.

446



## 2 WAY VALVES



VALVES FOR DRY OR LUBRICATED AIR,  
NEUTRAL GASES AND LIQUIDS



# 2/2

Actuation	Body	Function	Port Size	Orifice (mm)	Flow Factor Kv(l/min)	MOPD (bar)	Max Fluid Temp. (°C)	Page Parker Valves	
Direct Operated	Brass/Pipe Mounting	Normally Closed	1/8"	1.5 to 3	4.5	70	130	22	
			1/4"	1.2 to 5	11	100	130	22 and 24	
			3/8"	4 to 6	12	10	120	26	
			1/2"	8.5 to 11	36	4	120	26	
		Normally Open	1/8"	2.5	3.5	30	140	28	
			1/4"	1.5 to 4.5	7.8	40	140	28	
			Control by Electric Impulse	1/4"	3 to 5	11	20	100	28
		Brass/Sub-base Mounting	Normally Closed	5 mm	1.5 to 3	4.5	100	130	30
			Normally Open	5 mm	1.5	1.5	20	120	32
		Magnalift	Brass/Pipe Mounting	Normally Closed	3/8"	15	65	20	140
1/2"	15				65	20	140	34	
3/4"	15				80	20	140	36	
1"	15 to 25				170	20	120	38	
Pilot Operated	Brass/Pipe Mounting	Normally Closed	1/4"	8 to 12	36	40	120	40	
			3/8"	11 to 12	50	40	120	42	
			1/2"	11 to 15	60	40	120	44	
			3/4"	15 to 20	135	40	120	46	
			1"	18 to 25	185	16	120	48	
			1 1/4"	28	270	16	120	48	
			1 1/2"	40	425	16	120	50	
			2"	40	540	16	120	50	
			Normally Open	1/4"	8	36	40	140	52
				3/8"	11	50	40	140	52
				1/2"	15	60	40	140	52
				3/4"	15 to 20	135	40	120	54
				1"	25	180	16	120	54
				1 1/4"	28	270	16	120	54
		1 1/2"		40	420	12	100	54	
		2"		40	540	12	120	54	
		Control by Electric Impulse		1/4"	12	32	12	100	56
				3/8"	12	45	12	100	56
			1/2"	12	50	12	100	56	
			3/4"	18	100	12	100	56	
			1"	18	110	12	100	56	
			Brass/Sub-base Mounting	Normally Closed	14 mm	14	45	40	140
		Normally Open		14 mm	14	46	40	120	58

## 2 WAY VALVES

# 2/2

### VALVES FOR DRY OR LUBRICATED AIR, NEUTRAL GASES AND LIQUIDS DIRECT OPERATED

#### BRASS

#### PIPE MOUNTING

#### NORMALLY CLOSED

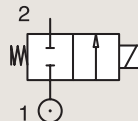

Port size (BSP)	Orifice Ø mm	Flow factors			Operating Pressure Differential			Fluid Temp. °C		Seat Seal	Valve Ref.	Housing Ref.	Coil Ref.	Power		Coil Group	Dwg. No.
		Kv l/min	KV m³/h	Qn m³/h	Min bar	Max(MOPD) AC bar	DC bar	Min °C	Max °C					AC W	DC W		
1/8"	1.5	0.9	0.05	70	0	20	12	-10	75	FKM	121M14	8993	481180	4	5	1.1	3382
	1.5	0.9	0.05	70	0	20	4	-10	75	FKM	121M14	8993	488980	2	2.5	1.1	3382
	1.5	1.5	0.09	80	0	60	25	-30	75	PCTFE	E121K14	2995	481865	8	9	2.0	3510
	1.5	1.5	0.09	80	0	70	30	-30	75	PCTFE	E121K14	4270	481000	8	8	2.0	3510
	1.5	1.5	0.09	80	0	70	55	-30	75	PCTFE	E121K14	4270	486265	14	14	2.0	3510
	2	2	0.12	125	0	10	7	-10	75	FKM	121M13	8993	481180	4	5	1.1	3382
	2	2	0.12	125	0	10	2.5	-10	75	FKM	121M13	8993	488980	2	2.5	1.1	3382
	2.5	2.8	0.17	-	0	10	10	-10	75	FKM	121Z03	2995	481865	8	9	2.0	7863
	2.5	3.5	0.21	220	0	28	10	-30	100	Ruby	E121K23	2995	481865	8	9	2.0	3510
	2.5	3.5	0.21	220	0	34	12	-30	130	Ruby	E121K23	4270	481000	8	8	2.0	3510
	2.5	3.5	0.21	220	0	50	22	-30	120	Ruby	E121K23	4270	486265	14	14	2.0	3510
	3	4.5	0.27	320	0	10	7	-10	100	FKM	121K1302	2995	481865	8	9	2.0	3510
3	4.5	0.27	320	0	10	8	-10	120	FKM	121K1302	4270	481000	8	8	2.0	3510	
3	4.5	0.27	320	0	10	10	-10	120	FKM	121K1302	4270	486265	14	14	2.0	3510	
1/4"	1.2	0.85	0.05	50	0	80	36	-30	100	Ruby	E121K65	2995	481865	8	9	2.0	3510
	1.2	0.85	0.05	50	0	100	43	-30	130	Ruby	E121K65	4270	481000	8	8	2.0	3510
	1.2	0.85	0.05	50	0	100	75	-30	120	Ruby	E121K65	4270	486265	14	14	2.0	3510
	1.5	1.5	0.09	80	0	-	8	-20	75	PUR	121K0497 <sub>1</sub>	2995	482740	-	1.6	6.0/8.0	8274
	1.5	1.5	0.09	80	0	-	8	-20	65	PUR	121K0497 <sub>1</sub>	2995	496125	-	1.6	6.0/8.0	8274
	1.5	1.5	0.09	80	0	10	10	-20	75	PUR	121K0497 <sub>1</sub>	-	495900	2.5	2	6.0/8.0	8274
	1.5	1.5	0.09	80	0	-	10	-20	75	PUR	121K0497 <sub>1</sub>	-	495910	-	0.3-1.2	6.0/8.0	8274
	1.5	1.5	0.09	80	0	60	25	-30	75	PCTFE	E121K04	2995	481865	8	9	2.0	3510
	1.5	1.5	0.09	80	0	70	30	-30	75	PCTFE	E121K04	4270	481000	8	8	2.0	3510
	1.5	1.5	0.09	80	0	70	55	-30	75	PCTFE	E121K04	4270	486265	14	14	2.0	3510
	1.5	1.5	0.09	80	0	20	20	-10	100	FKM	E121K0402	2995	481865	8	9	2.0/3.0	3510
	1.5	1.5	0.09	80	0	20	20	-10	120	FKM	E121K0402	4270	481000	8	8	2.0/3.0	3510
	1.5	1.5	0.09	80	0	60	25	-30	100	Ruby	E121K67	2995	481865	8	9	2.0	3510
	1.5	1.5	0.09	80	0	75	30	-30	130	Ruby	E121K67	4270	481000	8	8	2.0	3510
	1.5	1.5	0.09	80	0	100	55	-30	120	Ruby	E121K67	4270	486265	14	14	2.0	3510
	2.5	3.5	0.21	220	0	14	7	-10	100	FKM	121K0706	2995	481865	8	9	2.0	3510
	2.5	3.5	0.21	220	0	14	9	-10	120	FKM	121K0706	4270	481000	8	8	2.0	3510
	2.5	3.5	0.21	220	0	14	14	-10	120	FKM	121K0706	4270	486265	14	14	2.0	3510
	2.5	3.5	0.21	220	0	28	10	-30	75	PCTFE	E121K07	2995	481865	8	9	2.0	3510
	2.5	3.5	0.21	220	0	34	12	-30	75	PCTFE	E121K07	4270	481000	8	8	2.0	3510
2.5	3.5	0.21	220	0	50	22	-30	75	PCTFE	E121K07	4270	486265	14	14	2.0	3510	

Notes:

1.If fluid is water, media temperature shall not exceed 40°C



## 2 WAY VALVES



For this page	Port size	Orifice (mm)	Kv (l/min)	MOPD (bar)	Fluid Temp (°C)
From	1/8"	1.2	0.9	2.5	-30
To	1/4"	3	4.5	100	130

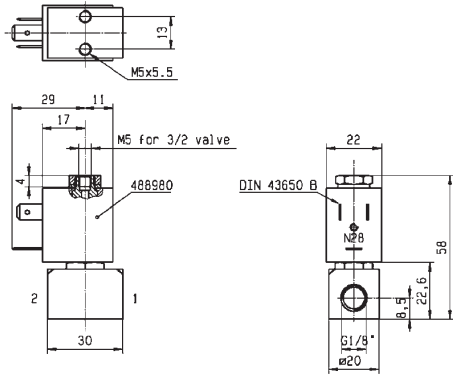

Drawing 3382

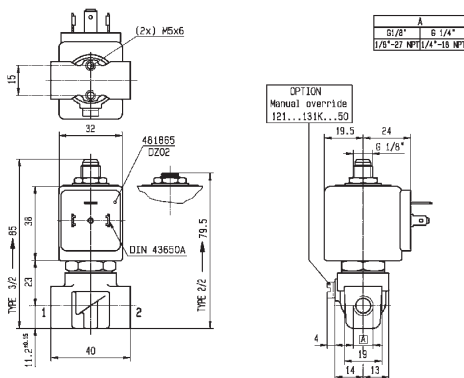

Drawing 3510

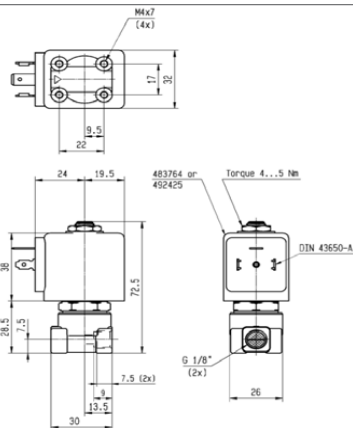

Drawing 7863

## 2 WAY VALVES

# 2/2

### VALVES FOR DRY OR LUBRICATED AIR, NEUTRAL GASES AND LIQUIDS DIRECT OPERATED

#### BRASS

#### PIPE MOUNTING

#### NORMALLY CLOSED

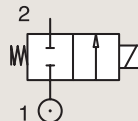

Port size (BSP)	Orifice Ø mm	Flow factors			Operating Pressure Differential			Fluid Temp. °C		Seat Seal	Valve Ref.	Housing Ref.	Coil Ref.	Power		Coil Group	Dwg. No.
		Kv l/min	KV m³/h	Qn m³/h	Min bar	AC bar	DC bar	Min °C	Max °C					AC W	DC W		
1/4"	2.5	3.5	0.21	220	0	28	10	-30	100	Ruby	E121K63	2995	481865	8	9	2.0	3510
	2.5	3.5	0.21	220	0	34	12	-30	130	Ruby	E121K63	4270	481000	8	8	2.0	3510
	2.5	3.5	0.21	220	0	50	22	-30	120	Ruby	E121K63	4270	486265	14	14	2.0	3510
	3	3.5	0.21	250	0	-	2	-20	75	PUR	121K0397 <sub>1</sub>	2995	482740	-	1.6	6.0/8.0	8274
	3	3.5	0.21	250	0	-	2	-20	65	PUR	121K0397 <sub>1</sub>	2995	496125	-	1.6	6.0/8.0	8274
	3	3.5	0.21	250	0	4.5	4	-20	75	PUR	121K0397 <sub>1</sub>	-	495900	2.5	2	6.0/8.0	8274
	3	3.5	0.21	250	0	-	4.5	-20	75	PUR	121K0397 <sub>1</sub>	-	495910	-	0.3-1.2	6.0/8.0	8274
	3	4.5	0.27	320	0	20	7	-30	75	PCTFE	E121K03	2995	481865	8	9	2.0/3.0	3510
	3	4.5	0.27	320	0	25	8.5	-30	75	PCTFE	E121K03	4270	481000	8	8	2.0/3.0	3510
	3	4.5	0.27	320	0	36	15	-30	75	PCTFE	E121K03	4270	486265	14	14	2.0/3.0	3510
	3	4.5	0.27	320	0	10	7	-10	100	FKM	E121K0302	2995	481865	8	9	2.0	3510
	3	4.5	0.27	320	0	10	8.5	-10	120	FKM	E121K0302	4270	481000	8	8	2.0	3510
	3	4.5	0.27	320	0	10	7	-10	100	FKM	E121K0302	4270	486265	14	14	2.0	3510
	3	4.5	0.27	320	0	10	7	-10	100	FKM	E121K0352 <sub>2</sub>	2995	481865	8	9	2.0	3510
	3	4.5	0.27	320	0	10	8.5	-10	120	FKM	E121K0352 <sub>2</sub>	4270	481000	8	8	2.0	3510
	3	4.5	0.27	320	0	10	10	-10	120	FKM	E121K0352 <sub>2</sub>	4270	486265	14	14	2.0	3510
	3	4.5	0.27	320	0	20	7	-30	100	Ruby	E121K64	2995	481865	8	9	2.0	3510
	3	4.5	0.27	320	0	25	8.5	-30	130	Ruby	E121K64	4270	481000	8	8	2.0	3510
	3	4.5	0.27	320	0	36	15	-30	120	Ruby	E121K64	4270	486265	14	14	2.0	3510
	4	7.5	0.45	480	0	10	4	-10	100	FKM	121K02	2995	481865	8	9	2.0	3510
	4	7.5	0.45	480	0	10	5	-10	120	FKM	121K02	4270	481000	8	8	2.0	3510
	4	7.5	0.45	480	0	10	10	-10	120	FKM	121K02	4270	486265	14	14	2.0	3510
	4	7.5	0.45	480	0	10	4	-10	100	FKM	121K0250 <sub>2</sub>	2995	481865	8	9	2.0	3510
	4	7.5	0.45	480	0	10	5	-10	120	FKM	121K0250 <sub>2</sub>	4270	481000	8	8	2.0	3510
	4	7.5	0.45	480	0	10	10	-10	120	FKM	121K0250 <sub>2</sub>	4270	486265	14	14	2.0	3510
	5	11	0.66	750	0	7	2	-10	100	FKM	121K01	2995	481865	8	9	2.0/14.2	3510
	5	11	0.66	750	0	7	2.8	-10	120	FKM	121K01	4270	481000	8	8	2.0/14.2	3510
	5	11	0.66	750	0	7	5	-10	120	FKM	121K01	4270	486265	14	14	2.0/14.2	3510
	5	11	0.66	750	0	7	2	-10	100	FKM	121K0150 <sub>2</sub>	2995	481865	8	9	2.0	3510
	5	11	0.66	750	0	7	2.8	-10	120	FKM	121K0150 <sub>2</sub>	4270	481000	8	8	2.0	3510
5	11	0.66	750	0	7	5	-10	120	FKM	121K0150 <sub>2</sub>	4270	486265	14	14	2.0	3510	
6.5	-	-	1400	0	0.5	0.5	-10	100	FKM	121K0601	2995	481865	8	9	2.0	3510	
6.5	-	-	1400	0	0.5	0.5	-10	120	FKM	121K0601	4270	481000	8	8	2.0	3510	

**Notes:**

- 1. If fluid is water, media temperature shall not exceed 40°C
- 2. With manual override



## 2 WAY VALVES



For this page	Port size	Orifice (mm)	Kv (l/min)	MOPD (bar)	Fluid Temp (°C)
From	1/4"	2.5	3.5	2	-30
To	1/4"	5	11	50	130

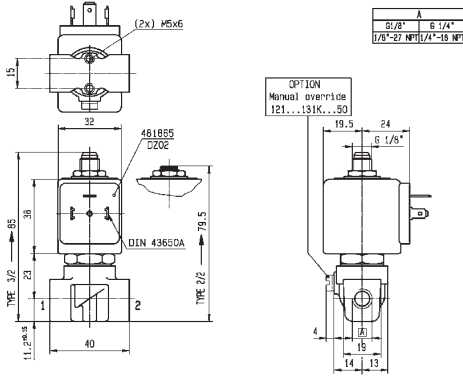

Drawing 3510

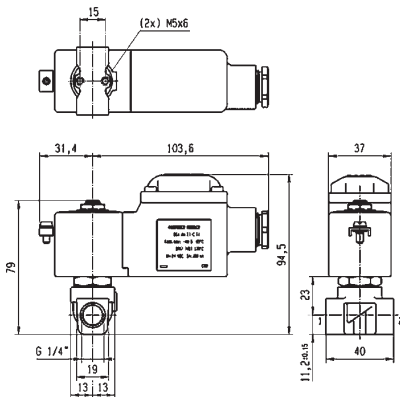

Drawing 8274

## 2 WAY VALVES

# 2/2

### VALVES FOR DRY OR LUBRICATED AIR, NEUTRAL GASES AND LIQUIDS DIRECT OPERATED

#### BRASS

#### PIPE MOUNTING

#### NORMALLY CLOSED

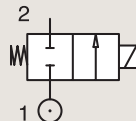

Port size (BSP)	Orifice Ø mm	Flow factors			Operating Pressure Differential			Fluid Temp.		Seat Seal	Valve Ref.	Housing Ref.	Coil Ref.	Power		Coil Group	Dwg. No.
		Kv l/min	KV m³/h	Qn m³/h	Min bar	Max(MOPD) AC bar	DC bar	Min °C	Max °C					AC W	DC W		
3/8"	4	7.5	0.45	480	0	10	4	-10	100	FKM	121K3206	2995	481865	8	9	2.0	3551
	4	7.5	0.45	480	0	10	5	-10	120	FKM	121K3206	4270	481000	8	8	2.0	3551
	4	7.5	0.45	480	0	10	10	-10	120	FKM	121K3206	4270	486265	14	14	2.0	3551
	5	11	0.66	750	0	7	2	-10	100	FKM	121K3106	2995	481865	8	9	2.0	3551
	5	11	0.66	750	0	7	2.8	-10	120	FKM	121K3106	4270	481000	8	8	2.0	3551
	5	11	0.66	750	0	7	5	-10	120	FKM	121K3106	4270	486265	14	14	2.0	3551
	6	12	0.72	1100	0	5	1.1	-10	100	FKM	121K3306	2995	481865	8	9	2.0/14.2	3551
	6	12	0.72	1100	0	5	1.5	-10	120	FKM	121K3306	4270	481000	8	8	2.0/14.2	3551
1/2"	6	12	0.72	1100	0	5	3	-10	120	FKM	121K3306	4270	486265	14	14	2.0/14.2	3551
	8.5	25	1.5	1600	0	1.1	0.5	-10	100	FKM	E121K46	2995	481865	8	9	2.0	3427
	8.5	25	1.5	1600	0	2.2	0.5	-10	120	FKM	E121K46	4270	481000	8	8	2.0	3427
	8.5	25	1.5	1600	0	4	1.2	-10	120	FKM	E121K46	4270	486265	14	14	2.0	3427
	11	36	2.16	2500	0	0.7	0.3	-10	100	FKM	E121K45	2995	481865	8	9	2.0	3427
	11	36	2.16	2500	0	1.2	0.35	-10	120	FKM	E121K45	4270	481000	8	8	2.0	3427
	11	36	2.16	2500	0	2.5	0.7	-10	120	FKM	E121K45	4270	486265	14	14	2.0	3427

## 2 WAY VALVES



For this page	Port size	Orifice (mm)	Kv (l/min)	MOPD (bar)	Fluid Temp (°C)
From	3/8"	4	7.5	0.3	-10
To	1/2"	11	36	10	120

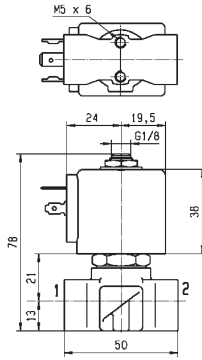

WEIGHT : 215 gr

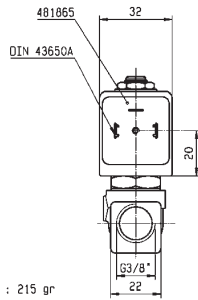

Drawing 3551

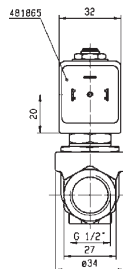
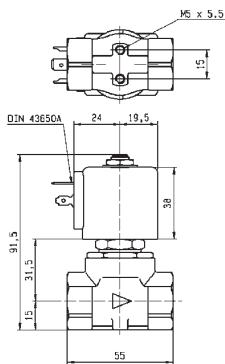

Drawing 3427

## 2 WAY VALVES

# 2/2

## VALVES FOR DRY OR LUBRICATED AIR, NEUTRAL GASES AND LIQUIDS DIRECT OPERATED

### BRASS

#### PIPE MOUNTING

#### NORMALLY OPEN

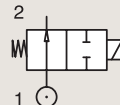

Port size	Orifice Ø	Flow factors			Operating Pressure Differential			Fluid Temp.		Seat Seal	Valve Ref.	Housing Ref.	Coil Ref.	Power		Coil Group	Dwg. No.
		Kv l/min	KV m³/h	Qn l/min	Min bar	Max(MOPD) AC bar	DC bar	Min °C	Max °C					AC W	DC W		
1/8"	2.5	3.5	0.21	-	0	30	-	-30	140	Ruby	122K9363	4270	481044	14	-	2.2	3510
	2.5	3.5	0.21	-	0	30	30	-30	140	Ruby	122K9363	4270	486265	14	14	2.2	3510
1/4"	1.5	1.5	0.09	80	0	30	30	-10	100	PCTFE	122K84	2995	481865	8	9	2.0	3510
	1.5	1.5	0.09	80	0	30	30	-10	100	PCTFE	122K84	4270	481000	8	8	2.0	3510
	1.5	1.5	0.09	80	0	30	30	-10	120	PCTFE	122K84	4270	486265	14	14	2.0	3510
	1.5	1.5	0.09	80	0	20	20	-10	100	FKM	122K8406	2995	481865	8	9	2.1	3510
	1.5	1.5	0.09	80	0	20	20	-10	120	FKM	122K8406	4270	481000	8	8	2.1	3510
	1.5	1.5	0.09	80	0	40	40	-30	100	Ruby	122K8408	2995	481865	8	9	2.0	3510
	1.5	1.5	0.09	80	0	40	40	-30	130	Ruby	122K8408	4270	481000	8	8	2.0	3510
	1.5	1.5	0.09	80	0	40	40	-30	130	Ruby	122K8408	4270	486265	14	14	2.0	3510
	2.5	3	0.18	180	0	12	12	-30	75	PCTFE	122K83	2995	481865	8	9	2.0	3510
	2.5	3	0.18	180	0	12	12	-30	75	PCTFE	122K83	4270	481000	8	8	2.0	3510
	2.5	3	0.18	180	0	12	12	-30	75	PCTFE	122K83	4270	486265	14	14	2.0	3510
	2.5	3	0.18	180	0	12	12	-10	100	FKM	122K8306	2995	481865	8	9	2.0	3510
	2.5	3	0.18	180	0	12	12	-10	120	FKM	122K8306	4270	481000	8	8	2.0	3510
	2.5	3	0.18	180	0	12	12	-10	120	FKM	122K8306	4270	486265	14	14	2.0	3510
	2.5	3.5	0.21	-	0	30	-	-30	140	Ruby	122K8363	4270	481044	14	-	2.2	3510
	2.5	3.5	0.21	-	0	30	30	-30	140	Ruby	122K8363	4270	486265	14	14	2.2	3510
4.5	7.8	0.47	-	0	4	4	-10	120	FKM	122K8606	2995	492425	14	14	-	3510	

Notes: 1. Valve compatible only with 492425 or 491514 coils

### BRASS

#### PIPE MOUNTING

#### CONTROL BY ELECTRIC IMPULSE

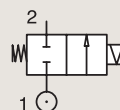

Port size	Orifice Ø	Flow factors			Operating Pressure Differential			Fluid Temp.		Seat Seal	Valve Ref.	Housing Ref.	Coil Ref.	Power		Coil Group	Dwg. No.
		Kv l/min	KV m³/h	Qn l/min	Min bar	Max(MOPD) AC bar	DC bar	Min °C	Max °C					AC W	DC W		
1/4"	3	4.5	0.27	320	0	20	-	-30	75	PCTFE	125K03	4269	484990	11	-	4.0	8296
	3	4.5	0.27	320	0	-	7	-30	75	PCTFE	125K03	4269	485400	-	13	4.0	8296
	5	11	0.66	750	0	5	-	-10	100	FKM	125K01	4269	484990	11	-	4.0	8296
	5	11	0.66	750	0	-	1.5	-10	100	FKM	125K01	4269	485400	-	13	4.0	8296



## 2 WAY VALVES



For this page	Port size	Orifice (mm)	Kv (l/min)	MOPD (bar)	Fluid Temp (°C)
From	1/8"	1.5	1.5	1.5	-30
To	1/4"	5	11	40	140

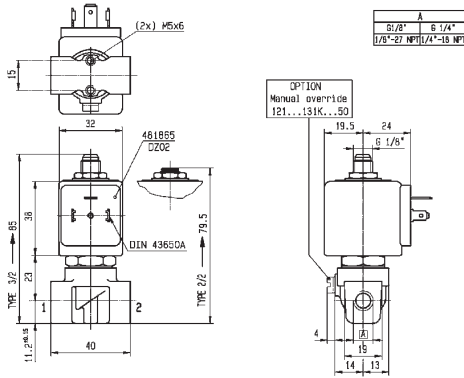

Drawing 3510

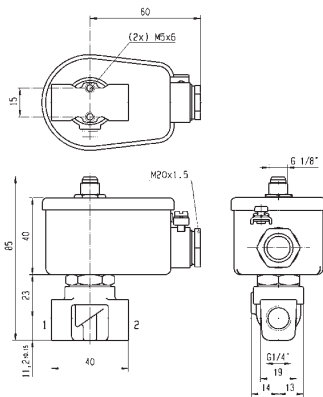

Drawing 8296

## 2 WAY VALVES

# 2/2

### VALVES FOR DRY OR LUBRICATED AIR, NEUTRAL GASES AND LIQUIDS DIRECT OPERATED

#### BRASS

#### SUB-BASE MOUNTING

#### NORMALLY CLOSED

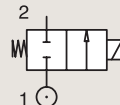

Port size	Orifice Ø mm	Flow factors			Operating Pressure Differential Max(MOPD)			Fluid Temp.		Seat Seal	Valve Ref.	Housing Ref.	Coil Ref.	Power		Coil Group	Dwg. No.
		Kv l/min	KV m³/h	Qn l/min	Min bar	AC bar	DC bar	Min °C	Max °C					AC W	DC W		
		0.09	80	0	20	-	-10	100	EPDM					121F4417	2995		
SB	1.5	1.5	0.09	80	0	60	25	-30	100	Ruby	121F67	2995	481865	8	9	2.0	3509
	1.5	1.5	0.09	80	0	75	30	-30	130	Ruby	121F67	4270	481000	8	8	2.0	3509
	1.5	1.5	0.09	80	0	100	55	-30	120	Ruby	121F67	4270	486265	14	14	2.0	3509
	1.5	1.5	0.09	80	0	60	25	-30	75	PCTFE	E121F44	2995	481865	8	9	2.0	3509
	1.5	1.5	0.09	80	0	70	30	-30	75	PCTFE	E121F44	4270	481000	8	8	2.0	3509
	1.5	1.5	0.09	80	0	70	55	-30	75	PCTFE	E121F44	4270	486265	14	14	2.0	3509
	1.5	1.5	0.09	80	0	20	20	-10	100	FKM	E121F4406	2995	481865	8	9	2.0	3509
	1.5	1.5	0.09	80	0	20	20	-10	120	FKM	E121F4406	4270	481000	8	8	2.0	3509
	1.5	1.5	0.09	80	0	20	20	-10	120	FKM	E121F4406	4270	486265	14	14	2.0	3509
	2.5	3.5	0.21	220	0	28	10	-30	75	PCTFE	121F47	2995	481865	8	9	2.0	3509
	2.5	3.5	0.21	220	0	34	12	-30	75	PCTFE	121F47	4270	481000	8	8	2.0	3509
	2.5	3.5	0.21	220	0	50	22	-30	75	PCTFE	121F47	4270	486265	14	14	2.0	3509
	2.5	3.5	0.21	220	0	14	7	-10	100	FKM	121F4706	2995	481865	8	9	2.0	3509
	2.5	3.5	0.21	220	0	14	9	-10	120	FKM	121F4706	4270	481000	8	8	2.0	3509
	2.5	3.5	0.21	220	0	14	14	-10	120	FKM	121F4706	4270	486265	14	14	2.0	3509
	2.5	3.5	0.21	220	0	28	10	-30	100	Ruby	121F63	2995	481865	8	9	2.0	3509
	2.5	3.5	0.21	220	0	34	12	-30	130	Ruby	121F63	4270	481000	8	8	2.0	3509
	2.5	3.5	0.21	220	0	50	22	-30	120	Ruby	121F63	4270	486265	14	14	2.0	3509
	3	4.5	0.27	320	0	20	7	-30	100	Ruby	121F64	2995	481865	8	9	2.0	3509
	3	4.5	0.27	320	0	25	8.5	-30	130	Ruby	121F64	4270	481000	8	8	2.0	3509
	3	4.5	0.27	320	0	36	15	-30	120	Ruby	121F64	4270	486265	14	14	2.0	3509
	3	4.5	0.27	320	0	20	7	-30	75	PCTFE	E121F43	2995	481865	8	9	2.0	3509
	3	4.5	0.27	320	0	25	8.5	-30	75	PCTFE	E121F43	4270	481000	8	8	2.0	3509
	3	4.5	0.27	320	0	36	15	-30	75	PCTFE	E121F43	4270	486265	14	14	2.0	3509
	3	4.5	0.27	320	0	10	7	-10	100	FKM	E121F4302	2995	481865	8	9	2.0/3.0	3509
	3	4.5	0.27	320	0	10	8.5	-10	120	FKM	E121F4302	4270	481000	8	8	2.0/3.0	3509
	3	4.5	0.27	320	0	10	10	-10	120	FKM	E121F4302	4270	486265	14	14	2.0/3.0	3509

## 2 WAY VALVES



For this page	Port size	Orifice (mm)	Kv (l/min)	MOPD (bar)	Fluid Temp (°C)
From	5 mm	1.5	1.5	7	-30
To	5 mm	3	4.5	100	130

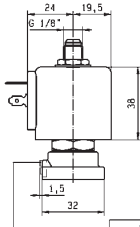
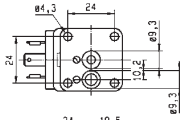

OPTION  
Manual override  
121...131F...50

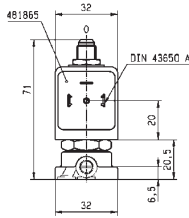

Drawing 3509

## 2 WAY VALVES

# 2/2

VALVES FOR DRY OR LUBRICATED AIR, NEUTRAL GASES AND LIQUIDS  
DIRECT OPERATED

BRASS

SUB-BASE MOUNTING

NORMALLY OPEN

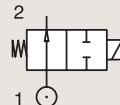

Port size	Orifice Ø mm	Flow factors			Operating Pressure Differential			Fluid Temp.		Seat Seal	Valve Ref.	Housing Ref.	Coil Ref.	Power		Coil Group	Dwg. No.
		Kv l/min	KV m³/h	Qn l/min	Min bar	Max(MOPD) AC bar	DC bar	Min °C	Max °C					AC W	DC W		
SB	1.5	1.5	0.09	80	0	20	20	-10	100	FKM	122F44	2995	481865	8	9	2.1	3509
	1.5	1.5	0.09	80	0	20	20	-10	120	FKM	122F44	4270	481000	8	8	2.1	3509

## 2 WAY VALVES



For this page	Port size	Orifice (mm)	Kv (l/min)	MOPD (bar)	Fluid Temp (°C)
From	5 mm	1.5	1.5	20	-10
To	5 mm	1.5	1.5	20	120

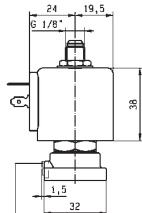
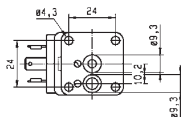

OPTION  
Manual override  
121...131F...50

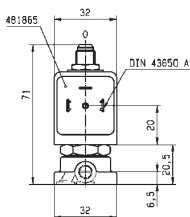

Drawing 3509

## 2 WAY VALVES

# 2/2

## VALVES FOR DRY OR LUBRICATED AIR, NEUTRAL GASES AND LIQUIDS MAGNALIFT

### BRASS

### PIPE MOUNTING

### NORMALLY CLOSED

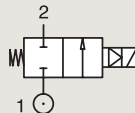

Port size	Orifice Ø	Flow factors			Operating Pressure Differential			Fluid Temp.		Seat Seal	Valve Ref.	Housing Ref.	Coil Ref.	Power		Coil Group	Dwg. No.
		Kv l/min	KV m³/h	Qn l/min	Min bar	Max(MOPD) AC bar	DC bar	Min °C	Max °C					AC W	DC W		
3/8"	15	65	3.9	4500	0	16	-	-10	100	NBR	221G13	2995	481865	8	-	2.0	3732
	15	65	3.9	4500	0	16	-	-10	100	NBR	221G13	4270	481000	8	-	2.0	3732
	15	65	3.9	4500	0	16	16	-10	100	NBR	221G13	4270	486265	14	14	2.0	3732
	15	65	3.9	4500	0	16	-	0	100	FKM	221G23 <sub>1</sub>	2995	481865	8	-	2.0	3732
	15	65	3.9	4500	0	16	-	0	120	FKM	221G23 <sub>1</sub>	4270	481000	8	-	2.0	3732
	15	65	3.9	4500	0	20	7	0	140	FKM	221G23 <sub>1</sub>	4270	486265	14	14	2.0	3732
	15	65	3.9	4500	0	-	10	-10	100	FKM	221G2330 <sub>12</sub>	2995	481865	-	9	2.1	3732
	15	65	3.9	4500	0	10	10	-10	65	FKM	221G2330 <sub>12</sub>	-	492070	9	8	2.1	3732
1/2"	15	65	3.9	4500	0	10	10	-10	75	FKM	221G2330 <sub>12</sub>	-	492190	11	9	2.1	3732
	15	65	3.9	4500	0	16	-	-10	100	NBR	221G15	2995	481865	8	-	2.0	3732
	15	65	3.9	4500	0	16	-	-10	100	NBR	221G15	4270	481000	8	-	2.0	3732
	15	65	3.9	4500	0	16	7	-10	100	NBR	221G15	4270	486265	14	14	2.0	3732
	15	65	3.9	4500	0	-	10	-10	100	NBR	221G1530 <sub>23</sub>	2995	481865	-	9	2.1	3732
	15	65	3.9	4500	0	10	10	-10	65	NBR	221G1530 <sub>23</sub>	-	492070	9	8	2.1	3732
	15	65	3.9	4500	0	10	10	-10	75	NBR	221G1530 <sub>23</sub>	-	492190	11	9	2.1	3732
	15	65	3.9	4500	0	16	-	0	100	FKM	221G25 <sub>1</sub>	2995	481865	8	-	2.0	3732
	15	65	3.9	4500	0	16	-	0	120	FKM	221G25 <sub>1</sub>	4270	481000	8	-	2.0	3732
	15	65	3.9	4500	0	20	7	0	140	FKM	221G25 <sub>1</sub>	4270	486265	14	14	2.0	3732
	15	65	3.9	4500	0	-	10	-10	100	FKM	221G2530 <sub>12</sub>	2995	481865	-	9	2.1	3732
	15	65	3.9	4500	0	10	10	-10	65	FKM	221G2530 <sub>12</sub>	-	492070	9	8	2.1	3732
15	65	3.9	4500	0	10	10	-10	75	FKM	221G2530 <sub>12</sub>	-	492190	11	9	2.1	3732	

#### Notes:

1. Valve only compatible with hydraulic oil and air/neutral gases
2. Valves with model number ending in 30 or 31 are mainly equipped with electrical parts for explosion proof applications or with standard DC coils.
3. With 4 position selector for controlled closure rate.
4. Pilot seat in FKM



## 2 WAY VALVES

UK  
CA  
IECEX certified



For this page	Port size	Orifice (mm)	Kv (l/min)	MOPD (bar)	Fluid Temp (°C)
From	3/8"	15	65	7	-10
To	1/2"	15	65	20	140

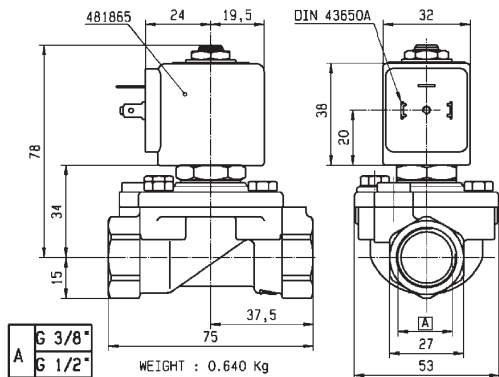

Drawing 3732

## 2 WAY VALVES

# 2/2

## VALVES FOR DRY OR LUBRICATED AIR, NEUTRAL GASES AND LIQUIDS MAGNALIFT

### BRASS

### PIPE MOUNTING

### NORMALLY CLOSED

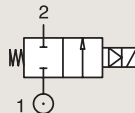

Port size	Orifice Ø	Flow factors			Operating Pressure Differential			Fluid Temp.		Seat Seal	Valve Ref.	Housing Ref.	Coil Ref.	Power		Coil Group	Dwg. No.
		Kv l/min	KV m³/h	Qn l/min	Min bar	Max(MOPD) AC bar	DC bar	Min °C	Max °C					AC W	DC W		
3/4"	15	80	4.8	6000	0	16	-	-10	100	NBR	221G16 <sub>4</sub>	2995	481865	8	-	2.0	3444
	15	80	4.8	6000	0	16	-	-10	100	NBR	221G16 <sub>4</sub>	4270	481000	8	-	2.0	3444
	15	80	4.8	6000	0	7	7	-10	100	NBR	221G16 <sub>4</sub>	4270	486265	14	14	2.0	3444
	15	80	4.8	6000	0	16	-	-10	100	NBR	221G1610 <sub>3</sub>	2995	481865	8	-	2.0	3444
	15	80	4.8	6000	0	16	-	-10	100	NBR	221G1610 <sub>3</sub>	4270	481000	8	-	2.0	3444
	15	80	4.8	6000	0	16	7	-10	100	NBR	221G1610 <sub>3</sub>	4270	486265	14	14	2.0	3444
	15	80	4.8	6000	0	10	10	-10	100	NBR	221G1630 <sub>24</sub>	2995	481865	8	9	2.1	3444
	15	80	4.8	6000	0	10	10	-25	40	NBR	221G1630 <sub>24</sub>	-	492070	9	8	2.1	3444
	15	80	4.8	6000	0	10	10	-25	40	NBR	221G1630 <sub>24</sub>	-	492190	11	9	2.1	3444
	15	80	4.8	6000	0	10	10	-10	100	NBR	221G1631 <sub>234</sub>	2995	481865	8	9	2.1	3444
	15	80	4.8	6000	0	10	10	-25	40	NBR	221G1631 <sub>234</sub>	-	492070	9	8	2.1	3444
	15	80	4.8	6000	0	10	10	-25	40	NBR	221G1631 <sub>234</sub>	-	492190	11	9	2.1	3444
	15	80	4.8	6000	0	16	-	0	100	FKM	221G26 <sub>1</sub>	2995	481865	8	-	2.0	3444
	15	80	4.8	6000	0	16	-	0	120	FKM	221G26 <sub>1</sub>	4270	481000	8	-	2.0	3444
	15	80	4.8	6000	0	20	7	0	140	FKM	221G26 <sub>1</sub>	4270	486265	14	14	2.0	3444
	15	80	4.8	6000	0	-	10	-10	100	FKM	221G2630 <sub>12</sub>	2995	481865	-	9	2.1	3444
	15	80	4.8	6000	0	10	10	-25	40	FKM	221G2630 <sub>12</sub>	-	492070	9	8	2.1	3444
	15	80	4.8	6000	0	10	10	-25	40	FKM	221G2630 <sub>12</sub>	-	492190	11	9	2.1	3444

#### Notes:

1. Valve only compatible with hydraulic oil and air/neutral gases
2. Valves with model number ending in 30 or 31 are mainly equipped with electrical parts for explosion proof applications or with standard DC coils.
3. With 4 position selector for controlled closure rate.
4. Pilot seat in FKM

## 2 WAY VALVES



For this page	Port size	Orifice (mm)	Kv (l/min)	MOPD (bar)	Fluid Temp (°C)
From	3/4"	15	80	7	-25
To	3/4"	15	80	20	140

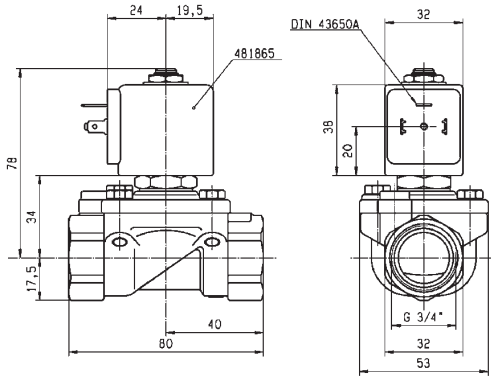

Drawing 3444

## 2 WAY VALVES

# 2/2

## VALVES FOR DRY OR LUBRICATED AIR, NEUTRAL GASES AND LIQUIDS MAGNALIFT

### BRASS

### PIPE MOUNTING

### NORMALLY CLOSED

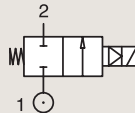

Port size	Orifice Ø	Flow factors			Operating Pressure Differential			Fluid Temp.		Seat Seal	Valve Ref.	Housing Ref.	Coil Ref.	Power		Coil Group	Dwg. No.
		Kv l/min	KV m³/h	Qn l/min	Min bar	Max(MOPD) AC bar	DC bar	Min °C	Max °C					AC W	DC W		
1"	15	80	4.8	6000	0	16	-	-10	100	NBR	221G17	2995	481865	8	-	2.0	3445
	15	80	4.8	6000	0	16	-	-10	100	NBR	221G17	4270	481000	8	-	2.0	3445
	15	80	4.8	6000	0	16	7	-10	100	NBR	221G17	4270	486265	14	14	2.0	3445
	15	80	4.8	6000	0	16	-	-10	100	NBR	221G1710 <sub>3</sub>	2995	481865	8	-	2.0	3445
	15	80	4.8	6000	0	16	-	-10	100	NBR	221G1710 <sub>3</sub>	4270	481000	8	-	2.0	3445
	15	80	4.8	6000	0	16	7	-10	100	NBR	221G1710 <sub>3</sub>	4270	486265	14	14	2.0	3445
	15	80	4.8	6000	0	-	10	-10	100	NBR	221G1730 <sub>24</sub>	2995	481865	-	9	2.1	3445
	15	80	4.8	6000	0	10	10	-10	65	NBR	221G1730 <sub>24</sub>	-	492070	9	8	2.1	3445
	15	80	4.8	6000	0	10	10	-10	75	NBR	221G1730 <sub>24</sub>	-	492190	11	9	2.1	3445
	15	80	4.8	6000	0	16	-	0	100	FKM	221G27 <sub>1</sub>	2995	481865	8	-	2.0	3445
	15	80	4.8	6000	0	16	-	0	120	FKM	221G27 <sub>1</sub>	4270	481000	8	-	2.0	3445
	15	80	4.8	6000	0	20	7	0	120	FKM	221G27 <sub>1</sub>	4270	486265	14	14	2.0	3445
	15	80	4.8	6000	0	-	10	0	100	FKM	221G2730 <sub>12</sub>	2995	481865	-	9	2.1	3445
	15	80	4.8	6000	0	10	10	-10	65	FKM	221G2730 <sub>12</sub>	-	492070	9	8	2.1	3445
	15	80	4.8	6000	0	10	10	-10	75	FKM	221G2730 <sub>12</sub>	-	492190	11	9	2.1	3445
	25	170	10.2	14000	0	16	-	-10	100	NBR	221G21	2995	481865	8	-	2.0	3448
	25	170	10.2	14000	0	16	-	-10	100	NBR	221G21	4270	481000	8	-	2.0	3448
	25	170	10.2	14000	0	16	6	-10	100	NBR	221G21	4270	486265	14	14	2.0	3448
	25	160	9.6	14000	0	16	-	0	100	FKM	221G2106 <sub>1</sub>	2995	481865	8	-	2.0	3448
	25	160	9.6	14000	0	16	-	0	120	FKM	221G2106 <sub>1</sub>	4270	481000	8	-	2.0	3448
	25	160	9.6	14000	0	16	6	0	120	FKM	221G2106 <sub>1</sub>	4270	486265	14	14	2.0	3448
	25	160	9.6	14000	0	16	-	-10	100	NBR	221G2110 <sub>3</sub>	2995	481865	8	-	2.0	3448
	25	160	9.6	14000	0	16	-	-10	100	NBR	221G2110 <sub>3</sub>	4270	481000	8	-	2.0	3448
	25	160	9.6	14000	0	16	6	-10	100	NBR	221G2110 <sub>3</sub>	4270	486265	14	14	2.0	3448
	25	170	10.2	14000	0	-	10	-10	40	NBR	221G2130 <sub>124</sub>	2995	481865	-	9	2.1	3448
	25	170	10.2	14000	0	10	10	-10	40	NBR	221G2130 <sub>124</sub>	-	492070	9	8	2.1	3448
	25	170	10.2	14000	0	10	10	-10	40	NBR	221G2130 <sub>124</sub>	-	492190	11	9	2.1	3448
	25	170	10.2	14000	0	-	10	0	100	FKM	221G2136 <sub>12</sub>	2995	481865	-	9	2.0	3448
	25	170	10.2	14000	0	-	10	0	100	FKM	221G2136 <sub>12</sub>	4270	481000	-	8	2.0	3448

#### Notes:

1. Valve only compatible with hydraulic oil and air/neutral gases
2. Valves with model number ending in 30 or 31 are mainly equipped with electrical parts for explosion proof applications or with standard DC coils.
3. With 4 position selector for controlled closure rate.
4. Pilot seat in FKM



## 2 WAY VALVES



For this page	Port size	Orifice (mm)	Kv (l/min)	MOPD (bar)	Fluid Temp (°C)
From	1"	15	80	6	-10
To	1"	25	170	20	120

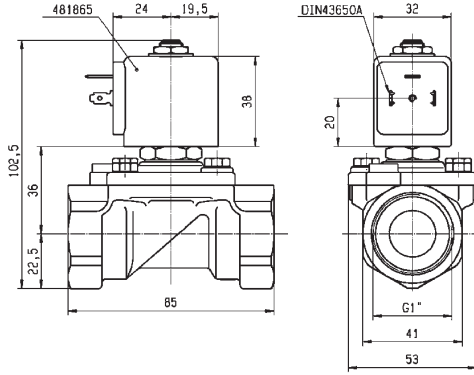

Drawing 3445

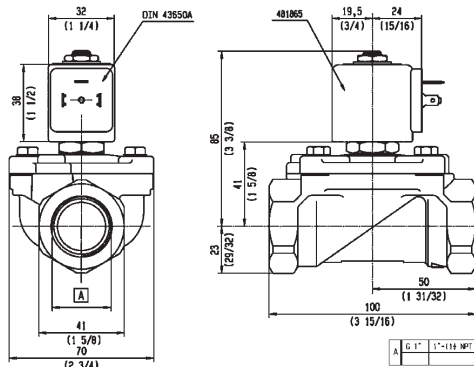

Drawing 3448

## 2 WAY VALVES

# 2/2

### VALVES FOR DRY OR LUBRICATED AIR, NEUTRAL GASES AND LIQUIDS PILOT OPERATED

#### BRASS

#### PIPE MOUNTING

#### NORMALLY CLOSED

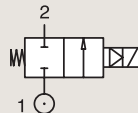

Port size (BSP)	Orifice Ø mm	Flow factors			Operating Pressure Differential			Fluid Temp.		Seat Seal	Valve Ref.	Housing Ref.	Coil Ref.	Power		Coil Group	Dwg. No.
		Kv l/min	KV m³/h	Qn m³/h	Min bar	AC bar	DC bar	Min °C	Max °C					AC W	DC W		
1/4"	8	36	2.16	1600	0.3	40	25	-10	100	NBR	E321H11 <sup>124</sup>	2995	481865	8	9	2.0	3523
	8	36	2.16	1600	0.3	40	30	-10	100	NBR	E321H11 <sup>124</sup>	4270	481000	8	8	2.0	3523
	8	36	2.16	1600	0.3	40	40	-10	100	NBR	E321H11 <sup>124</sup>	4270	486265	14	14	2.0	3523
	11	28	1.68	1800	0.2	10	3	-10	100	NBR	E321K10	2995	481865	8	9	2.0	3429
	11	28	1.68	1800	0.2	10	4	-10	100	NBR	E321K10	4270	481000	8	8	2.0	3429
	12	30	1.8	2150	0.3	10	10	-10	100	NBR	321K31	8993	481180	4	5	1.1	7093
	12	30	1.8	2150	0.3	10	7	-10	75	NBR	321K31	8993	488980	2	2.5	1.1	7093
	12	30	1.8	2150	0.3	10	10	-10	100	FKM	321K3106	8993	481180	4	5	1.1	7093
	12	30	1.8	2150	0.3	10	7	-10	75	FKM	321K3106	8993	488980	2	2.5	1.1	7093
	12	32	1.92	2150	0.3	12	12	-10	100	FKM	321K4156 <sup>3</sup>	2995	481865	8	9	2.1/3.0	7094
	12	32	1.92	2150	0.3	12	12	-10	120	FKM	321K4156 <sup>3</sup>	4270	481000	8	8	2.1/3.0	7094

#### Notes:

1. Minimum pressure differential = 0.3 bar for opening and 0 bar for closing
2. Pilot seat disc in synthetic Ruby
3. Valve with manual override
4. With 4 position selector for controlled closure rate

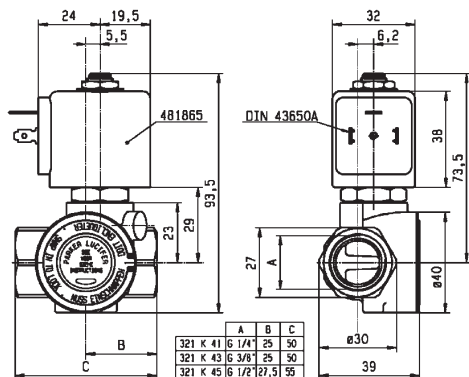

Drawing 7094



## 2 WAY VALVES



For this page	Port size	Orifice (mm)	Kv (l/min)	MOPD (bar)	Fluid Temp (°C)
From	1/4"	8	28	3	-10
To	1/4"	12	36	40	120

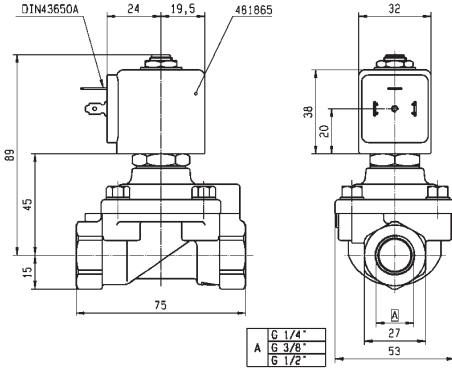

Drawing 3523

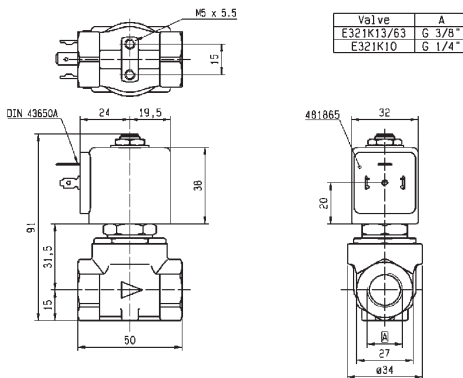

Drawing 3429

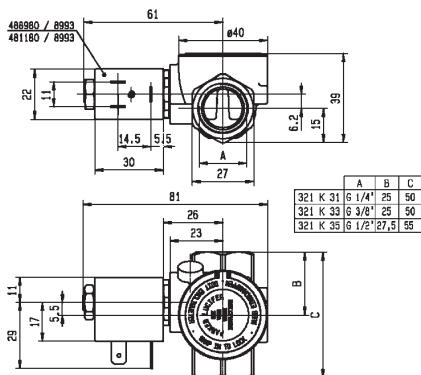

Drawing 7093



## 2 WAY VALVES

# 2/2

### VALVES FOR DRY OR LUBRICATED AIR, NEUTRAL GASES AND LIQUIDS PILOT OPERATED

#### BRASS

#### PIPE MOUNTING

#### NORMALLY CLOSED

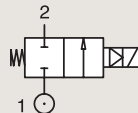

Port size (BSP)	Orifice Ø mm	Flow factors			Operating Pressure Differential			Fluid Temp.		Seat Seal	Valve Ref.	Housing Ref.	Coil Ref.	Power		Coil Group	Dwg. No.
		Kv l/min	KV m³/h	Qn m³/h	Min bar	Max(MOPD) AC bar	DC bar	Min °C	Max °C					AC W	DC W		
3/8"	11	50	3	2800	0.3	40	25	-10	100	NBR	E321H13 <sup>124</sup>	2995	481865	8	9	2.0	3521
	11	50	3	2800	0.3	40	30	-10	100	NBR	E321H13 <sup>124</sup>	4270	481000	8	8	2.0	3521
	11	50	3	2800	0.3	40	40	-10	100	NBR	E321H13 <sup>124</sup>	4270	486265	14	14	2.0	3521
	11	36	2.16	2500	0.2	10	4	-10	100	NBR	E321K13	4270	481000	8	8	2.0	3429
	11	36	2.16	2500	0.2	10	10	-10	100	NBR	E321K13	4270	486265	14	14	2.0	3429
	11	36	2.16	2500	0.2	10	-	-10	100	NBR	E321K1314	2995	483466	8-11	-	2.0	3429
	11	36	2.16	2500	0.2	10	10	-10	100	NBR	E321K1314	4270	486265	14	14	2.0	3429
	12	45	2.7	3050	0.3	10	10	-10	100	NBR	321K33	8993	481180	4	5	1.1	7093
	12	45	2.7	3050	0.3	10	7	-10	75	NBR	321K33	8993	488980	2	2.5	1.1	7093
	12	45	2.7	3050	0.3	10	10	-10	100	FKM	321K3306 <sup>1</sup>	8993	481180	4	5	1.1	7093
	12	45	2.7	3050	0.3	10	7	-10	75	FKM	321K3306 <sup>1</sup>	8993	488980	2	2.5	1.1	7093
	12	45	2.7	3050	0.3	12	12	-10	100	FKM	321K4356 <sup>3</sup>	2995	481865	8	9	2.1/3.0	7094
12	45	2.7	3050	0.3	12	12	-10	120	FKM	321K4356 <sup>3</sup>	4270	481000	8	8	2.1/3.0	7094	

#### Notes:

1. Minimum pressure differential = 0.3 bar for opening and 0 bar for closing
2. Pilot seat disc in synthetic Ruby
3. Valve with manual override
4. With 4 position selector for controlled closure rate

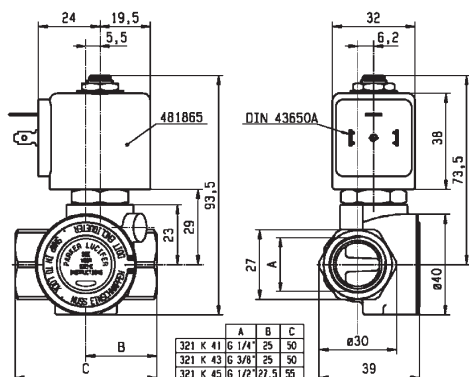

Drawing 7094



## 2 WAY VALVES



For this page	Port size	Orifice (mm)	Kv (l/min)	MOPD (bar)	Fluid Temp (°C)
From	3/8"	11	36	4	-10
To	3/8"	12	50	40	120

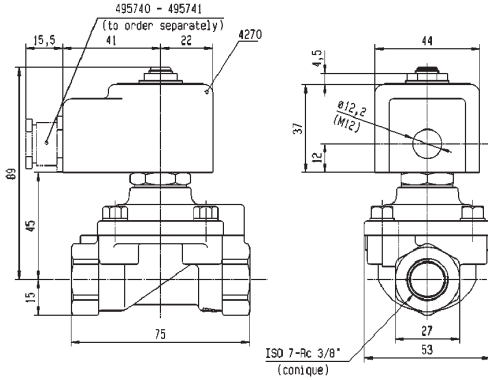

Drawing 3521

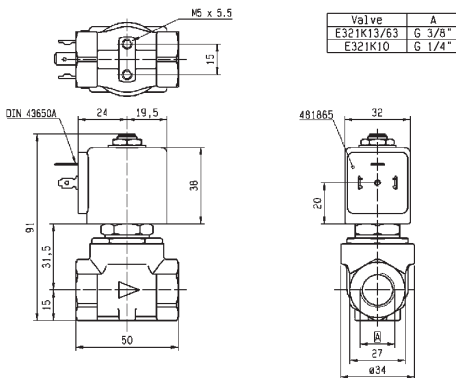

Drawing 3429

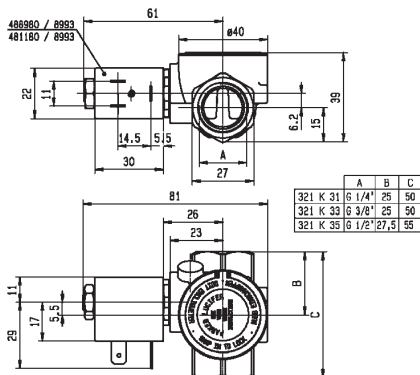

Drawing 7093



## 2 WAY VALVES

# 2/2

### VALVES FOR DRY OR LUBRICATED AIR, NEUTRAL GASES AND LIQUIDS PILOT OPERATED

#### BRASS

#### PIPE MOUNTING

#### NORMALLY CLOSED

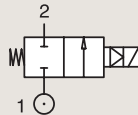

Port size (BSP)	Orifice Ø mm	Flow factors			Operating Pressure Differential			Fluid Temp. °C		Seat Seal	Valve Ref.	Housing Ref.	Coil Ref.	Power		Coil Group	Dwg. No.
		Kv l/min	KV m³/h	Qn m³/h	Min bar	AC bar	DC bar	Min °C	Max °C					AC W	DC W		
1/2"	11	36	2.16	2500	0.2	10	3	-10	100	NBR	E321K15	2995	481865	8	9	2.0	3427
	11	36	2.16	2500	0.2	10	10	-10	120	NBR	E321K15	4270	486265	14	14	2.0	3427
	11	36	2.16	2500	0.2	10	3	-10	100	FKM	E321K25	2995	481865	8	9	2.0	3427
	11	36	2.16	2500	0.2	4	4	-10	65	FKM	E321K25	-	492070	9	8	2.0	3427
	12	50	3	3400	0.3	12	12	-10	100	NBR	321K35	8993	481180	4	5	1.1	7093
	12	50	3	3400	0.3	10	7	-10	75	NBR	321K35	8993	488980	2	2.5	1.1	7093
	12	50	3	3400	0.3	12	12	-10	100	FKM	321K3506	8993	481180	4	5	1.1	7093
	12	50	3	3400	0.3	10	7	-10	75	FKM	321K3506	8993	488980	2	2.5	1.1	7093
	15	60	3.6	3150	0.3	-	10	-10	55	NBR	321H1590	2995	48358001	-	0.5-3	7.0/8.0	3978
	15	60	3.6	3150	0.3	-	10	-10	80	NBR	321H1590	-	495910	-	0.3-1.2	7.0/8.0	3978
	15	60	3.6	3150	1.5	40	40	-10	50	PUR	321H35 <sub>2</sub>	2995	481865	8	9	2.1	3522
	15	60	3.6	3150	1.5	40	40	-10	50	PUR	321H35 <sub>2</sub>	4270	481000	8	8	2.1	3522
	15	60	3.6	3150	0.3	40	25	-10	100	NBR	E321H15 <sup>124</sup>	2995	481865	8	9	2.0	3522
	15	60	3.6	3150	0.3	40	30	-10	100	NBR	E321H15 <sup>124</sup>	4270	481000	8	8	2.0	3522
	15	60	3.6	3150	0.3	40	40	-10	100	NBR	E321H15 <sup>124</sup>	4270	486265	14	14	2.0	3522

#### Notes:

1. Minimum pressure differential = 0.3 bar for opening and 0 bar for closing
2. Pilot seat disc in synthetic Ruby
3. Valve with manual override
4. With 4 position selector for controlled closure rate

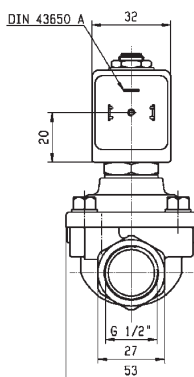
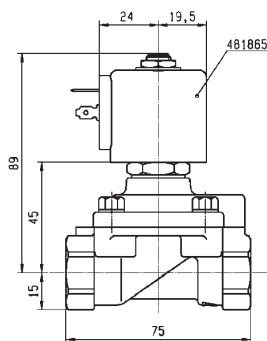

Drawing 3522



## 2 WAY VALVES



For this page	Port size	Orifice (mm)	Kv (l/min)	MOPD (bar)	Fluid Temp (°C)
From	1/2"	11	36	3	-10
To	1/2"	15	60	40	120

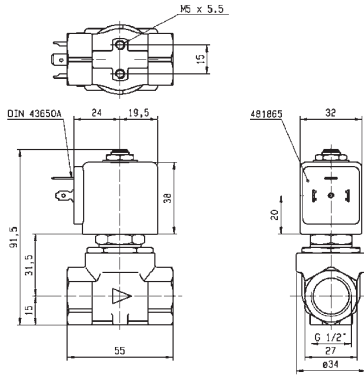

Drawing 3427

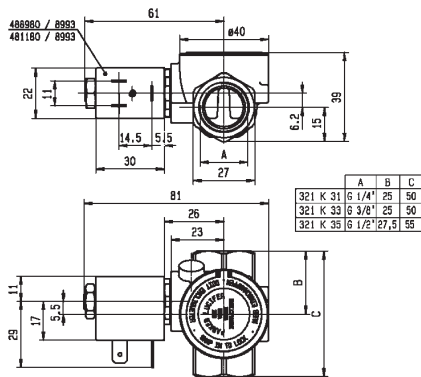

Drawing 7093

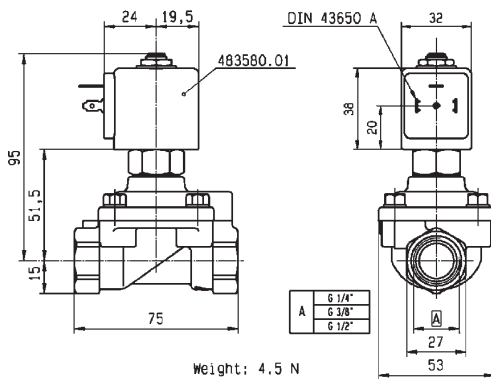

Drawing 3978

## 2 WAY VALVES

# 2/2

### VALVES FOR DRY OR LUBRICATED AIR, NEUTRAL GASES AND LIQUIDS PILOT OPERATED

#### BRASS

#### PIPE MOUNTING

#### NORMALLY CLOSED

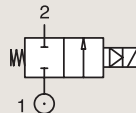

Port size (BSP)	Orifice Ø mm	Flow factors			Operating Pressure Differential			Fluid Temp.		Seat Seal	Valve Ref.	Housing Ref.	Coil Ref.	Power		Coil Group	Dwg. No.
		Kv l/min	KV m³/h	Qn m³/h	Min bar	Max(MOPD) AC bar	DC bar	Min °C	Max °C					AC W	DC W		
3/4"	15	60	3.6	3550	1.5	40	40	-10	50	PUR	321H36	2995	481865	8	9	2.1	3696
	15	60	3.6	3550	1.5	40	40	-10	50	PUR	321H36	4270	481000	8	8	2.1	3696
	18	100	6	9400	0.3	10	10	-10	100	NBR	321K36	8993	481180	4	5	1.1	7097
	18	100	6	9400	0.3	10	7	-10	75	NBR	321K36	8993	488980	2	2.5	1.1	7097
	18	100	6	9400	0.3	10	10	-10	100	FKM	321K3606	8993	481180	4	5	1.1	7097
	18	100	6	9400	0.3	10	7	-10	75	FKM	321K3606	8993	488980	2	2.5	1.1	7097
	20	135	8.1	9500	0.3	16	16	-10	100	NBR	E321G36	2995	481865	8	9	2.0	3442
	20	135	8.1	9500	0.3	16	16	-10	100	NBR	E321G36	4270	481000	8	8	2.0	3442
	20	135	8.1	9500	0.3	16	16	-10	100	FKM	E321G3606	2995	481865	8	9	2.0/14.1	3442
	20	135	8.1	9500	0.3	16	16	-10	120	FKM	E321G3606	4270	481000	8	8	2.0/14.1	3442
	20	135	8.1	9500	0.3	16	16	-10	120	FKM	E321G3606	4270	486265	14	14	2.0/14.1	3442



## 2 WAY VALVES



For this page	Port size	Orifice (mm)	Kv (l/min)	MOPD (bar)	Fluid Temp (°C)
From	3/4"	15	60	7	-10
To	3/4"	20	135	40	120

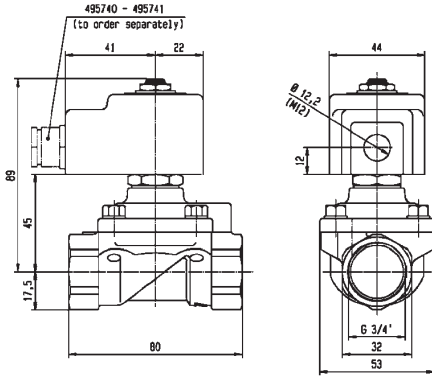

Drawing 3696

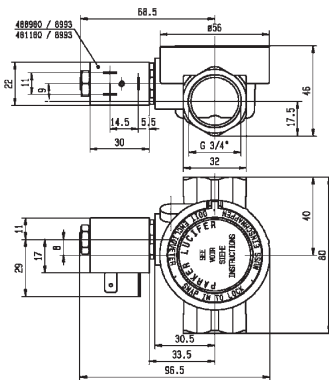

Drawing 7097

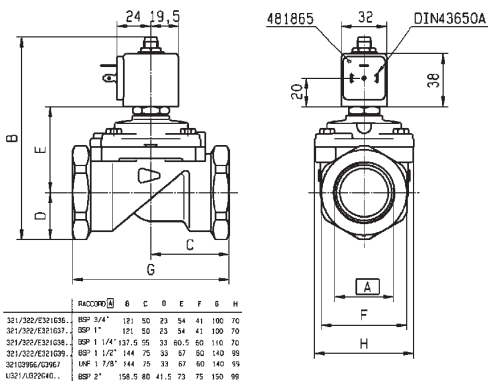

Drawing 3442

Part No.	Orifice	A	B	C	D	E	F	G	H
311/302/E321038..	3/4"	191	50	23	54	41	100	70	
311/302/E321037..	1"	121	50	23	54	41	100	70	
311/302/E321038..	3/4"	137.5	55	33	60.5	60	110	70	
311/302/E321039..	1/2"	144	75	33	67	60	140	99	
311/302/E321040..	1/2"	144	75	33	67	60	140	99	
311/302/E321041..	1/2"	144	75	33	67	60	140	99	
311/302/E321042..	1/2"	144	75	33	67	60	140	99	
311/302/E321043..	1/2"	144	75	33	67	60	140	99	
311/302/E321044..	1/2"	144	75	33	67	60	140	99	
311/302/E321045..	1/2"	144	75	33	67	60	140	99	
311/302/E321046..	1/2"	144	75	33	67	60	140	99	
311/302/E321047..	1/2"	144	75	33	67	60	140	99	
311/302/E321048..	1/2"	144	75	33	67	60	140	99	
311/302/E321049..	1/2"	144	75	33	67	60	140	99	
311/302/E321050..	1/2"	144	75	33	67	60	140	99	
311/302/E321051..	1/2"	144	75	33	67	60	140	99	
311/302/E321052..	1/2"	144	75	33	67	60	140	99	
311/302/E321053..	1/2"	144	75	33	67	60	140	99	
311/302/E321054..	1/2"	144	75	33	67	60	140	99	
311/302/E321055..	1/2"	144	75	33	67	60	140	99	
311/302/E321056..	1/2"	144	75	33	67	60	140	99	
311/302/E321057..	1/2"	144	75	33	67	60	140	99	
311/302/E321058..	1/2"	144	75	33	67	60	140	99	
311/302/E321059..	1/2"	144	75	33	67	60	140	99	
311/302/E321060..	1/2"	144	75	33	67	60	140	99	
311/302/E321061..	1/2"	144	75	33	67	60	140	99	
311/302/E321062..	1/2"	144	75	33	67	60	140	99	
311/302/E321063..	1/2"	144	75	33	67	60	140	99	
311/302/E321064..	1/2"	144	75	33	67	60	140	99	
311/302/E321065..	1/2"	144	75	33	67	60	140	99	
311/302/E321066..	1/2"	144	75	33	67	60	140	99	
311/302/E321067..	1/2"	144	75	33	67	60	140	99	
311/302/E321068..	1/2"	144	75	33	67	60	140	99	
311/302/E321069..	1/2"	144	75	33	67	60	140	99	
311/302/E321070..	1/2"	144	75	33	67	60	140	99	
311/302/E321071..	1/2"	144	75	33	67	60	140	99	
311/302/E321072..	1/2"	144	75	33	67	60	140	99	
311/302/E321073..	1/2"	144	75	33	67	60	140	99	
311/302/E321074..	1/2"	144	75	33	67	60	140	99	
311/302/E321075..	1/2"	144	75	33	67	60	140	99	
311/302/E321076..	1/2"	144	75	33	67	60	140	99	
311/302/E321077..	1/2"	144	75	33	67	60	140	99	
311/302/E321078..	1/2"	144	75	33	67	60	140	99	
311/302/E321079..	1/2"	144	75	33	67	60	140	99	
311/302/E321080..	1/2"	144	75	33	67	60	140	99	
311/302/E321081..	1/2"	144	75	33	67	60	140	99	
311/302/E321082..	1/2"	144	75	33	67	60	140	99	
311/302/E321083..	1/2"	144	75	33	67	60	140	99	
311/302/E321084..	1/2"	144	75	33	67	60	140	99	
311/302/E321085..	1/2"	144	75	33	67	60	140	99	
311/302/E321086..	1/2"	144	75	33	67	60	140	99	
311/302/E321087..	1/2"	144	75	33	67	60	140	99	
311/302/E321088..	1/2"	144	75	33	67	60	140	99	
311/302/E321089..	1/2"	144	75	33	67	60	140	99	
311/302/E321090..	1/2"	144	75	33	67	60	140	99	
311/302/E321091..	1/2"	144	75	33	67	60	140	99	
311/302/E321092..	1/2"	144	75	33	67	60	140	99	
311/302/E321093..	1/2"	144	75	33	67	60	140	99	
311/302/E321094..	1/2"	144	75	33	67	60	140	99	
311/302/E321095..	1/2"	144	75	33	67	60	140	99	
311/302/E321096..	1/2"	144	75	33	67	60	140	99	
311/302/E321097..	1/2"	144	75	33	67	60	140	99	
311/302/E321098..	1/2"	144	75	33	67	60	140	99	
311/302/E321099..	1/2"	144	75	33	67	60	140	99	
311/302/E321100..	1/2"	144	75	33	67	60	140	99	



## 2 WAY VALVES

# 2/2

### VALVES FOR DRY OR LUBRICATED AIR, NEUTRAL GASES AND LIQUIDS PILOT OPERATED

#### BRASS

#### PIPE MOUNTING

#### NORMALLY CLOSED

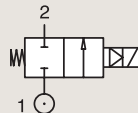

Port size (BSP)	Orifice Ø mm	Flow factors			Operating Pressure Differential Max(MOPD)			Fluid Temp.		Seat Seal	Valve Ref.	Housing Ref.	Coil Ref.	IS	Power		Coil Group	Dwg. No.
		Kv l/min	KV m³/h	Qn m³/h	Min bar	AC bar	DC bar	Min °C	Max °C						AC W	DC W		
1"	18	110	6.6	10150	0.3	10	10	-10	100	NBR	321K37	8993	481180		4	5	1.1	7098
	18	110	6.6	10150	0.3	10	7	-10	75	NBR	321K37	8993	488980		2	2.5	1.1	7098
	18	110	6.6	10150	0.3	10	10	-10	100	FKM	321K3706	8993	481180		4	5	1.1	7098
	18	110	6.6	10150	0.3	10	7	-10	75	FKM	321K3706	8993	488980		2	2.5	1.1	7098
	25	185	11.1	14100	0.3	-	10	-10	55	NBR	321G3790 <sub>1</sub>	2995	48358001	*	-	0.5-3	7.0/8.0	3442
	25	185	11.1	14100	0.3	-	10	-10	75	NBR	321G3790 <sub>1</sub>	-	495910	*	-	0.3-1.2	7.0/8.0	3442
	25	180	10.8	14000	0.3	16	16	-10	100	NBR	E321G37	2995	481865		8	9	2.0	3442
	25	180	10.8	14000	0.3	16	16	-10	100	NBR	E321G37	4270	481000		8	8	2.0	3442
	25	180	10.8	14000	0.3	16	16	-10	100	FKM	E321G3706	2995	481865		8	9	2.0/14.1	3442
	25	180	10.8	14000	0.3	16	16	-10	120	FKM	E321G3706	4270	481000		8	8	2.0/14.1	3442
1 1/4"	28	270	16.2	18000	0.3	16	16	-10	100	NBR	E321G38	2995	481865		8	9	2.0	3442
	28	270	16.2	18000	0.3	16	16	-10	100	NBR	E321G38	4270	481000		8	8	2.0	3442
	28	270	16.2	18000	0.3	16	16	-10	100	FKM	E321G3806	2995	481865		8	9	2.0	3442
	28	270	16.2	18000	0.3	16	16	-10	120	FKM	E321G3806	4270	481000		8	8	2.0	3442
	28	270	16.2	18000	0.3	16	16	-10	100	FKM	E321G3806	4270	486265		14	14	2.0	3442

Notes:

1. Pilot seat disc in FKM

## 2 WAY VALVES



For this page	Port size	Orifice (mm)	Kv (l/min)	MOPD (bar)	Fluid Temp (°C)
From	1"	18	110	7	-10
To	1 1/4"	28	270	16	120

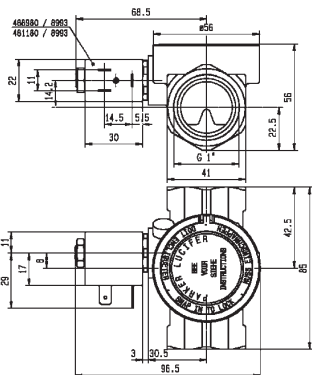

Drawing 7098

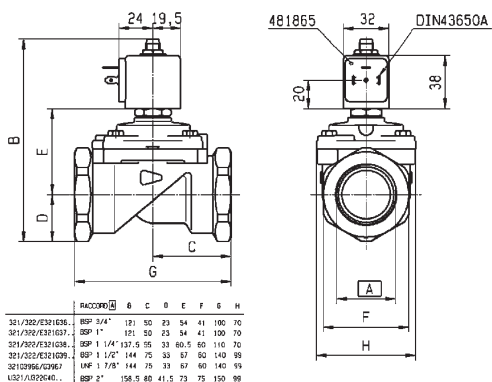

Drawing 3442

## 2 WAY VALVES

# 2/2

## VALVES FOR DRY OR LUBRICATED AIR, NEUTRAL GASES AND LIQUIDS PILOT OPERATED

### BRASS

### PIPE MOUNTING

### NORMALLY CLOSED

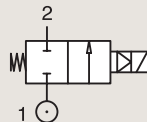

Port size (BSP)	Orifice Ø mm	Flow factors			Operating Pressure Differential			Fluid Temp.		Seat Seal	Valve Ref.	Housing Ref.	Coil Ref.	IS		Power		Coil Group	Dwg. No.
		Kv l/min	KV m³/h	Qn m³/h	Min bar	Max(MOPD) AC bar	DC bar	Min °C	Max °C					AC W	DC W				
1 1/2"	40	425	25.5	31500	0.5	-	10	-10	55	NBR	321G3990	2995	48358001	*	-	0.5-3	7.0/8.0	8113	
	40	425	25.5	31500	0.5	-	10	-10	75	NBR	321G3990	-	495910	*	-	0.3-1.2	7.0/8.0	8113	
	40	420	25.2	31500	0.3	16	7	-10	100	NBR	E321G39 <sub>1</sub>	2995	481865		8	9	2.0	3442	
	40	420	25.2	31500	0.3	16	8	-10	100	NBR	E321G39 <sub>1</sub>	4270	481000		8	8	2.0	3442	
	40	420	25.2	31500	0.3	16	16	-10	100	NBR	E321G39 <sub>1</sub>	4270	486265		14	14	2.0	3442	
	40	420	25.2	31500	0.3	16	7	-10	100	FKM	E321G3906	2995	481865		8	9	2.0	3442	
	40	420	25.2	31500	0.3	16	8	-10	120	FKM	E321G3906	4270	481000		8	8	2.0	3442	
	40	420	25.2	31500	0.3	16	16	-10	100	FKM	E321G3906	4270	486265		14	14	2.0	3442	
2"	40	540	32.4	38100	0.5	-	10	-10	55	FKM	321G4090	2995	48358001	*	-	0.5-3	7.0/8.0	8113	
	40	540	32.4	38100	0.5	-	10	-10	75	FKM	321G4090	-	495910	*	-	0.3-1.2	7.0/8.0	8113	
	40	540	32.4	40000	0.3	16	7	-10	100	NBR	E321G40 <sub>1</sub>	2995	481865		8	9	2.0	3442	
	40	540	32.4	40000	0.3	16	8	-10	100	NBR	E321G40 <sub>1</sub>	4270	481000		8	8	2.0	3442	
	40	540	32.4	40000	0.3	16	16	-10	100	NBR	E321G40 <sub>1</sub>	4270	486265		14	14	2.0	3442	
	40	540	32.4	40000	0.3	16	7	-10	100	FKM	E321G4006	2995	481865		8	9	2.0	3442	
	40	540	32.4	40000	0.3	16	8	-10	120	FKM	E321G4006	4270	481000		8	8	2.0	3442	
	40	540	32.4	40000	0.3	16	16	-10	120	FKM	E321G4006	4270	486265		14	14	2.0	3442	

#### Notes:

1. Pilot seat disc in synthetic Ruby



## 2 WAY VALVES



For this page	Port size	Orifice (mm)	Kv (l/min)	MOPD (bar)	Fluid Temp (°C)
From	1 1/2"	40	420	7	-10
To	2"	40	540	16	120

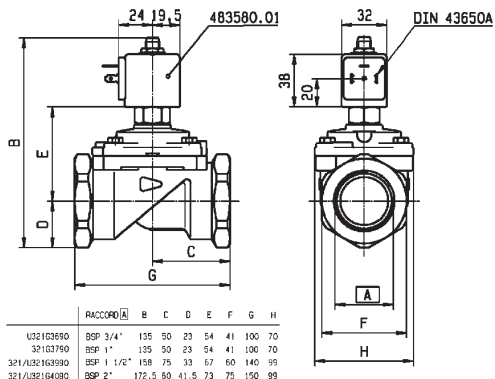

Drawing 8113

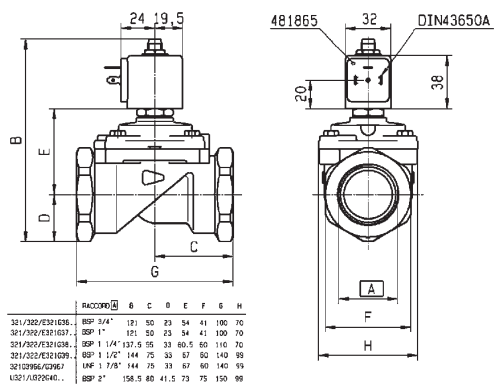

Drawing 3442

## 2 WAY VALVES

# 2/2

### VALVES FOR DRY OR LUBRICATED AIR, NEUTRAL GASES AND LIQUIDS PILOT OPERATED

#### BRASS

#### PIPE MOUNTING

#### NORMALLY OPEN

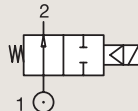

Port size (BSP)	Orifice Ø mm	Flow factors			Operating Pressure Differential			Fluid Temp. °C		Seat Seal	Valve Ref.	Housing Ref.	Coil Ref.	Power		Coil Group	Dwg. No.
		Kv l/min	KV m³/h	Qn m³/h	Min bar	Max(MOPD) AC bar	DC bar	Min °C	Max °C					AC W	DC W		
1/4"	8	36	2.16	1600	0.3	40	25	-10	100	NBR	322H71 <sub>12</sub>	2995	481865	8	9	2.0	3523
	8	36	2.16	1600	0.3	40	30	-10	100	NBR	322H71 <sub>12</sub>	4270	481000	8	8	2.0	3523
	8	36	2.16	1600	0.3	40	40	-10	100	NBR	322H71 <sub>12</sub>	4270	486265	14	14	2.0	3523
	8	36	2.16	1600	0.3	40	40	-10	100	FKM	322H7106 <sub>12</sub>	2995	481865	8	9	2.0/14.1	3523
	8	36	2.16	1600	0.3	40	40	-10	120	FKM	322H7106 <sub>12</sub>	4270	481000	8	8	2.0/14.1	3523
	8	36	2.16	1600	0.3	40	40	-10	140	FKM	322H7106 <sub>12</sub>	4270	486265	14	14	2.0/14.1	3523
3/8"	11	50	3	3240	0.3	40	40	-10	75	NBR	322H73 <sub>12</sub>	2995	481865	8	9	2.0	3523
	11	50	3	3240	0.3	40	40	-10	75	NBR	322H73 <sub>12</sub>	4270	481000	8	8	2.0	3523
	11	50	3	3240	0.3	40	40	-10	75	NBR	322H73 <sub>12</sub>	4270	486265	14	14	2.0	3523
	11	50	3	3240	0.3	40	40	-10	100	FKM	322H7306 <sub>12</sub>	2995	481865	8	9	2.0/14.1	3523
	11	50	3	3240	0.3	40	40	-10	100	FKM	322H7306 <sub>12</sub>	4270	481000	8	8	2.0/14.1	3523
	11	50	3	3240	0.3	40	40	-10	140	FKM	322H7306 <sub>12</sub>	4270	486265	14	14	2.0/14.1	3523
1/2"	15	60	3.6	3890	0.3	15	15	-10	100	NBR	322G75	2995	481865	8	9	2.1	3522
	15	60	3.6	3890	0.3	15	15	-10	100	NBR	322G75	4270	481000	8	8	2.1	3522
	15	60	3.6	3890	0.3	20	20	-10	100	FKM	322G7506 <sub>1</sub>	2995	481865	8	9	2.0	3522
	15	60	3.6	3890	0.3	20	20	-10	100	FKM	322G7506 <sub>1</sub>	4270	481000	8	8	2.0	3522
	15	60	3.6	3890	0.3	20	20	-10	100	FKM	322G7506 <sub>1</sub>	4270	486265	14	14	2.0	3522
	15	60	3.6	3150	1.5	40	40	-10	50	PUR	322H35 <sub>3</sub>	2995	481865	8	9	2.1	7569
	15	60	3.6	3150	1.5	40	40	-10	50	PUR	322H35 <sub>3</sub>	4270	481000	8	8	2.1	7569
	15	60	3.6	3890	0.3	40	40	-10	100	NBR	322H75 <sub>12</sub>	2995	481865	8	9	2.0	3522
	15	60	3.6	3890	0.3	40	40	-10	100	NBR	322H75 <sub>12</sub>	4270	481000	8	8	2.0	3522
	15	60	3.6	3890	0.3	40	40	-10	100	NBR	322H75 <sub>12</sub>	4270	486265	14	14	2.0	3522
	15	60	3.6	3890	0.3	40	40	-10	100	FKM	322H7506 <sub>12</sub>	2995	481865	8	9	2.0/14.1	3522
	15	60	3.6	3890	0.3	40	40	-10	120	FKM	322H7506 <sub>12</sub>	4270	481000	8	8	2.0/14.1	3522
	15	60	3.6	3890	0.3	40	40	-10	140	FKM	322H7506 <sub>12</sub>	4270	486265	14	14	2.0/14.1	3522

**Notes:**

1. Minimum pressure differential = 0.3 bar for opening and 0 bar for closing
2. Pilot seat disc in synthetic Ruby
3. Valve only compatible with air and neutral gases



## 2 WAY VALVES



For this page	Port size	Orifice (mm)	Kv (l/min)	MOPD (bar)	Fluid Temp (°C)
From	1/4"	8	36	15	-10
To	1/2"	15	60	40	140

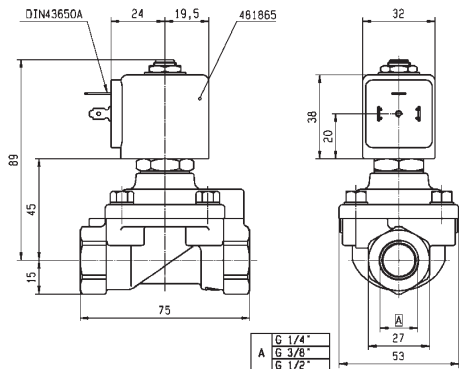

Drawing 3523

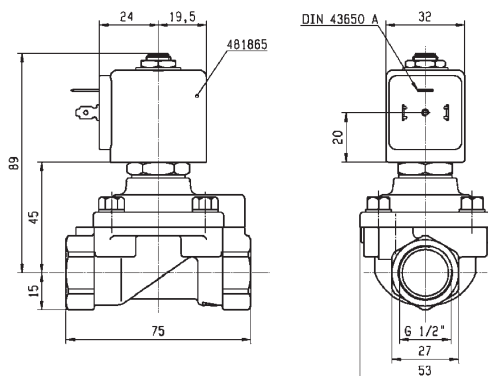

Drawing 3522

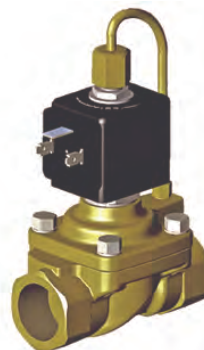
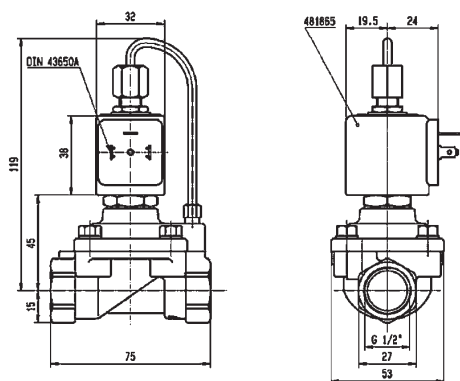

Drawing 7569

## 2 WAY VALVES

# 2/2

## VALVES FOR DRY OR LUBRICATED AIR, NEUTRAL GASES AND LIQUIDS PILOT OPERATED

### BRASS

### PIPE MOUNTING

### NORMALLY OPEN

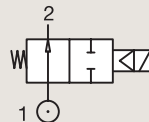

Port size (BSP)	Orifice Ø mm	Flow factors			Operating Pressure Differential			Fluid Temp.		Seat Seal	Valve Ref.	Housing Ref.	Coil Ref.	Power		Coil Group	Dwg. No.
		Kv l/min	KV m³/h	Qn m³/h	Min bar	Max(MOPD) AC bar DC bar	Min °C	Max °C	AC W					DC W			
3/4"	15	53.3	3.2	3550	1.5	40	40	-10	50	PUR	322H36 <sub>12</sub>	2995	481865	8	9	2.1	7570
	15	53.3	3.2	3550	1.5	40	40	-10	50	PUR	322H36 <sub>12</sub>	4270	481000	8	8	2.1	7570
	20	135	8.1	9500	0.3	16	16	-10	100	NBR	322G36	2995	481865	8	9	2.1	3442
	20	135	8.1	9500	0.3	16	16	-10	100	NBR	322G36	4270	481000	8	8	2.1	3442
	20	135	8.1	9500	0.3	16	16	-10	100	FKM	322G3606	2995	481865	8	9	2.1	3442
	20	135	8.1	9500	0.3	16	16	-10	120	FKM	322G3606	4270	481000	8	8	2.1	3442
1"	25	180	10.8	14000	0.3	16	16	-10	100	NBR	322G37	2995	481865	8	9	2.1	3442
	25	180	10.8	14000	0.3	16	16	-10	100	NBR	322G37	4270	481000	8	8	2.1	3442
	25	180	10.8	14000	0.3	16	16	-10	100	FKM	322G3706	2995	481865	8	9	2.1	3442
	25	180	10.8	14000	0.3	16	16	-10	120	FKM	322G3706	4270	481000	8	8	2.1	3442
1 1/4"	28	270	16.2	18000	0.3	16	16	-10	100	NBR	322G38	2995	481865	8	9	2.1	3442
	28	270	16.2	18000	0.3	16	16	-10	100	NBR	322G38	4270	481000	8	8	2.1	3442
	28	270	16.2	18000	0.3	16	16	-10	100	FKM	322G3806	2995	481865	8	9	2.1	3442
1 1/2"	28	270	16.2	18000	0.3	16	16	-10	120	FKM	322G3806	4270	481000	8	8	2.1	3442
	40	420	25.2	31500	0.3	12	12	-10	100	NBR	322G39	2995	481865	8	9	2.1	3442
	40	420	25.2	31500	0.3	12	12	-10	100	NBR	322G39	4270	481000	8	8	2.1	3442
	40	420	25.2	31500	0.3	12	12	-10	100	FKM	322G3906	2995	481865	8	9	2.1	3442
2"	40	420	25.2	31500	0.3	12	12	-10	100	FKM	322G3906	4270	481000	8	8	2.1	3442
	40	540	32.4	40000	0.3	12	12	-10	100	NBR	322G40	2995	481865	8	9	2.1	3442
	40	540	32.4	40000	0.3	12	12	-10	100	NBR	322G40	4270	481000	8	8	2.1	3442
	40	540	32.4	40000	0.3	12	12	-10	100	FKM	322G4006	2995	481865	8	9	2.1	3442
40	540	32.4	40000	0.3	12	12	-10	120	FKM	322G4006	4270	481000	8	8	2.1	3442	

#### Notes:

1. Minimum pressure differential = 1.5 bar for opening and 0.3 bar for closing
2. Valve only compatible with air and neutral gases



## 2 WAY VALVES



For this page	Port size	Orifice (mm)	Kv (l/min)	MOPD (bar)	Fluid Temp (°C)
From	3/4"	15	53.3	12	-10
To	2"	40	540	40	120

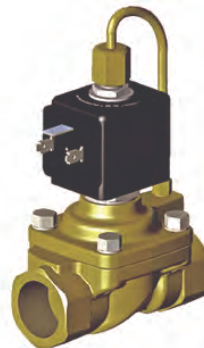
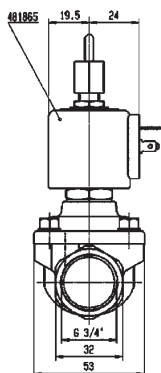
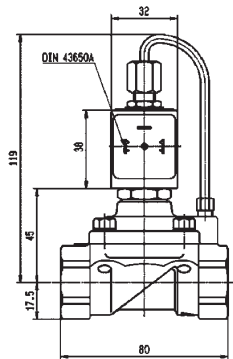

Drawing 7570

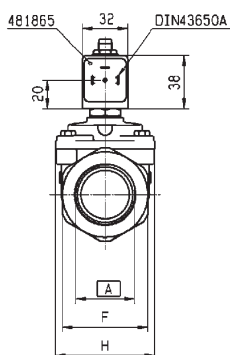
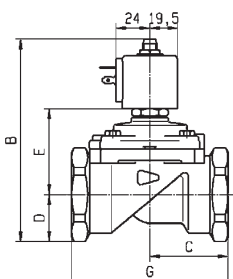

Drawing 3442

PACORP	B	C	D	E	F	G	H	
311/322/E311E36..	BSP 3/4"	121	50	23	54	41	100	70
311/332/E321G37..	BSP 1"	121	50	23	54	41	100	70
311/330/E311G38..	BSP 1 1/4"	137.5	55	33	60.5	60	110	70
321/322/E311G29..	BSP 1 1/2"	144	75	33	67	60	140	95
32102956/G2967	UNF 1 7/8"	144	75	33	67	60	140	95
U321/1020640..	BSP 2"	158.5	80	41.5	73	75	150	99

## 2 WAY VALVES

# 2/2

## VALVES FOR DRY OR LUBRICATED AIR, NEUTRAL GASES AND LIQUIDS PILOT OPERATED

### BRASS

### PIPE MOUNTING

### CONTROL BY ELECTRIC IMPULSE

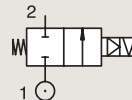

Port size	Orifice Ø	Flow factors			Operating Pressure Differential			Fluid Temp.		Seat Seal	Valve Ref.	Housing Ref.	Coil Ref.	Power		Coil Group	Dwg. No.
		Kv l/min	KV m³/h	Qn l/min	Min bar	Max(MOPD) AC bar	DC bar	Min °C	Max °C					AC W	DC W		
1/4"	12	32	1.92	2150	0.3	12	-	-10	100	FKM	325K4106	4269	484990	11	-	4.0	7094
	12	32	1.92	2150	0.3	-	12	-10	100	FKM	325K4106	4269	485400	-	13	4.0	7094
3/8"	12	45	2.7	3050	0.3	12	-	-10	100	FKM	325K4306	4269	484990	11	-	4.0	7094
	12	45	2.7	3050	0.3	-	12	-10	100	FKM	325K4306	4269	485400	-	13	4.0	7094
1/2"	12	50	3	3400	0.3	12	-	-10	100	FKM	325K4506	4269	484990	11	-	4.0	7094
	12	50	3	3400	0.3	-	12	-10	100	FKM	325K4506	4269	485400	-	13	4.0	7094
3/4"	18	100	6	9400	0.3	12	-	-10	100	FKM	325K4606	4269	484990	11	-	4.0	7099
	18	100	6	9400	0.3	-	12	-10	100	FKM	325K4606	4269	485400	-	13	4.0	7099
1"	18	110	6.6	10150	0.3	12	-	-10	100	FKM	325K4706	4269	484990	11	-	4.0	7100
	18	110	6.6	10150	0.3	-	12	-10	100	FKM	325K4706	4269	485400	-	13	4.0	7100

2 WAY VALVES



For this page	Port size	Orifice (mm)	Kv (l/min)	MOPD (bar)	Fluid Temp (°C)
From	1/4"	12	32	12	-10
To	1"	18	110	12	100

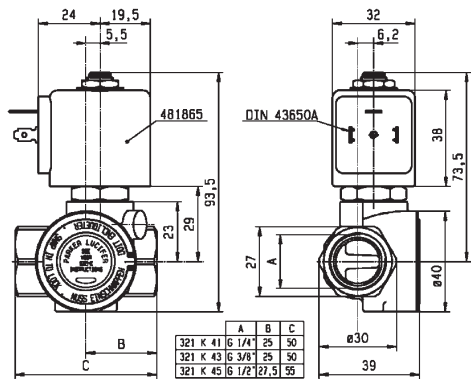

Drawing 7094

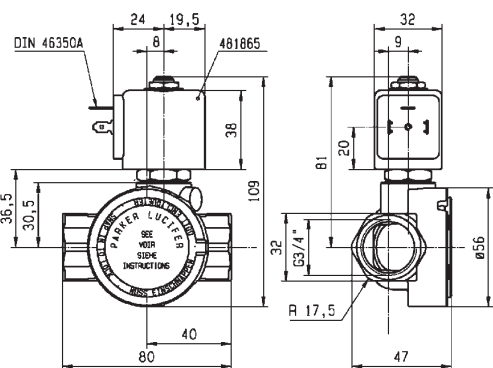

Drawing 7099

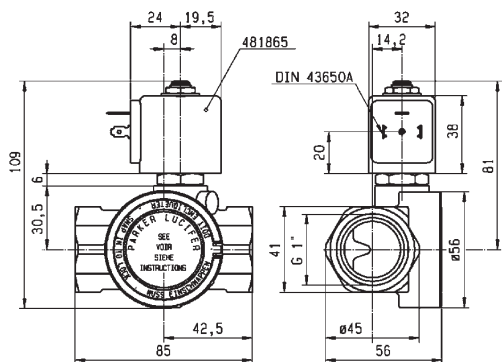

Drawing 7100



## 2 WAY VALVES

# 2/2

## VALVES FOR DRY OR LUBRICATED AIR, NEUTRAL GASES AND LIQUIDS PILOT OPERATED

### BRASS

#### SUB-BASE MOUNTING

#### NORMALLY CLOSED

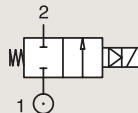

Port size	Orifice Ø mm	Flow factors			Operating Pressure Differential Max(MOPD)			Fluid Temp.		Seat Seal	Valve Ref.	Housing Ref.	Coil Ref.	Power		Coil Group	Dwg. No.
		Kv l/min	KV m³/h	Qn l/min	Min bar	AC bar	DC bar	Min °C	Max °C					AC W	DC W		
SB	14	-	-	2100	1.5	40	40	-10	50	PUR	321F35	2995	481865	8	9	2.0	3520
	14	-	-	2100	1.5	40	40	-10	50	PUR	321F35	2995	492425	14	14	2.0	3520
	14	-	-	2100	0	13	13	-10	50	PUR	421F35	2995	481865	8	9	2.1	3520
	14	45	2.7	2100	0.3	40	25	-10	100	NBR	E321F32 <sub>2</sub>	2995	481865	8	9	2.0	3520
	14	45	2.7	2100	0.3	40	30	-10	100	NBR	E321F32 <sub>2</sub>	4270	481000	8	8	2.0	3520
	14	45	2.7	2100	0.3	40	40	-10	100	NBR	E321F32 <sub>2</sub>	4270	486265	14	14	2.0	3520
	14	45	2.7	-	0.3	40	25	-10	100	FKM	E321F3202 <sub>1234</sub>	2995	481865	8	9	2.0	3520
	14	45	2.7	-	0.3	40	30	-10	120	FKM	E321F3202 <sub>1234</sub>	4270	481000	8	8	2.0	3520
	14	45	2.7	-	0.3	40	40	-10	140	FKM	E321F3202 <sub>1234</sub>	4270	486265	14	14	2.0	3520

#### Notes:

1. Minimum pressure differential = 0.3 bar for opening and 0 bar for closing
2. Pilot seat disc in synthetic Ruby
3. Valve only compatible with hydraulic oil and neutral liquids
4. With 4 position selector for controlled closure rate

### BRASS

#### SUB-BASE MOUNTING

#### NORMALLY OPEN

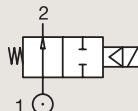

Port size	Orifice Ø mm	Flow factors			Operating Pressure Differential Max(MOPD)			Fluid Temp.		Seat Seal	Valve Ref.	Housing Ref.	Coil Ref.	Power		Coil Group	Dwg. No.
		Kv l/min	KV m³/h	Qn l/min	Min bar	AC bar	DC bar	Min °C	Max °C					AC W	DC W		
SB	14	-	-	2100	1.5	40	40	-10	50	PUR	322F35	2995	481865	8	9	2.1	7527
	14	46	2.76	-	0.3	40	40	-10	75	NBR	322F72 <sub>124</sub>	2995	481865	8	9	2.1	3520
	14	46	2.76	-	0.3	40	40	-10	75	NBR	322F72 <sub>124</sub>	4270	481000	8	8	2.1	3520
	14	45	2.7	-	0.3	40	40	0	100	FKM	322F7206 <sub>1234</sub>	2995	481865	8	9	2.1/14.1	3520
	14	45	2.7	-	0.3	40	40	0	120	FKM	322F7206 <sub>1234</sub>	4270	481000	8	8	2.1/14.1	3520

#### Notes:

1. Minimum pressure differential = 0.3 bar for opening and 0 bar for closing
2. Pilot seat disc in synthetic Ruby
3. Valve only compatible with hydraulic oil and neutral liquids
4. With 4 position selector for controlled closure rate



## 2 WAY VALVES



For this page	Port size	Orifice (mm)	Kv (l/min)	MOPD (bar)	Fluid Temp (°C)
From	14 mm	14	-	13	-10
To	14 mm	14	46	40	140

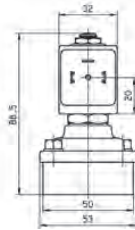
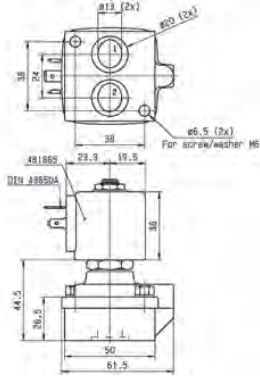

Drawing 3520

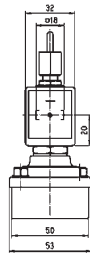
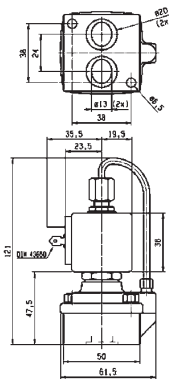

Drawing 7527



## 2 WAY VALVES



### VALVES FOR WATER AND NEUTRAL LIQUIDS



# 2/2

Actuation	Body	Function	Port Size	Orifice (mm)	Flow Factor Kv(l/min)	MOPD (bar)	Max Fluid Temp. (°C)	Page Parker Valves		
Direct Operated	Brass/Pipe Mounting	Normally Closed	1/8"	1.5 to 2	2	20	75	62		
			1/4"	1.5 to 5	11	20	120	62		
			3/8"	4 to 6	12	10	120	64		
			1/2"	8.5 to 11	36	4	120	64		
		Normally Open	1/4"	2.5	3	12	120	64		
		Control by Electric Impulse	1/4"	5	11	5	100	66		
	Brass/Sub-base Mounting	Normally Closed	5 mm	1.5 to 3	4.5	20	120	68		
Pilot Operated	Brass/Pipe Mounting	Normally Closed	1/4"	11 to 12	32	12	120	74		
			3/8"	11 to 13	50	20	140	70 and 74		
			1/2"	11 to 13	50	20	140	70 and 76		
			3/4"	18 to 20	140	20	140	70 and 78		
			1"	18 to 25	180	20	140	70 and 80		
			1 1/4"	28 to 35	420	16	140	72 and 80		
			1 1/2"	40	500	16	140	72 and 80		
			2"	40 to 50	620	16	140	72 and 80		
			Normally Open	1/4"	12	32	12	120	84	
			3/8"	12 to 13	50	20	140	82 and 84		
			1/2"	12 to 15	60	20	140	82 and 84		
			3/4"	18 to 20	140	20	140	82 and 84		
			1"	18 to 25	180	20	140	80 and 86		
			1 1/4"	35	420	10	140	82		
		1 1/2"	40	500	10	140	82 and 86			
		2"	50	620	10	140	82			
		2 1/2"	65	1100	10	90	82			
		3"	75	1334	10	90	82			
			Brass/Sub-base Mounting	Normally Closed	14 mm	14	45	40	100	86

## 2 WAY VALVES

# 2/2

## VALVES FOR WATER AND NEUTRAL LIQUIDS

### DIRECT OPERATED

#### BRASS

#### PIPE MOUNTING

#### NORMALLY CLOSED

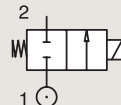

Port size	Orifice Ø	Flow factors			Operating Pressure Differential			Fluid Temp.		Seat Seal	Valve Ref.	Housing Ref.	Coil Ref.	Power		Coil Group	Dwg. No.
		Kv l/min	KV m³/h	Qn l/min	Min bar	Max(MOPD) DC bar	Min °C	Max °C	AC W					DC W			
1/8"	1.5	0.9	0.05	70	0	20	12	-10	75	FKM	121M14	8993	481180	4	5	1.1	3382
	1.5	0.9	0.05	70	0	20	4	-10	75	FKM	121M14	8993	488980	2	2.5	1.1	3382
	2	2	0.12	125	0	10	7	-10	75	FKM	121M13	8993	481180	4	5	1.1	3382
	2	2	0.12	125	0	10	2.5	-10	75	FKM	121M13	8993	488980	2	2.5	1.1	3382
1/4"	1.5	1.5	0.09	80	0	20	20	-10	100	FKM	E121K0402	2995	481865	8	9	2.0/3.0	3510
	1.5	1.5	0.09	80	0	20	20	-10	120	FKM	E121K0402	4270	481000	8	8	2.0/3.0	3510
	2.5	3.5	0.21	220	0	14	7	-10	100	FKM	121K0706	2995	481865	8	9	2.0	3510
	2.5	3.5	0.21	220	0	14	9	-10	120	FKM	121K0706	4270	481000	8	8	2.0	3510
	2.5	3.5	0.21	220	0	14	14	-10	120	FKM	121K0706	4270	486265	14	14	2.0	3510
	3	4.5	0.27	320	0	10	7	-10	100	FKM	E121K0302	2995	481865	8	9	2.0	3510
	3	4.5	0.27	320	0	10	8.5	-10	120	FKM	E121K0302	4270	481000	8	8	2.0	3510
	3	4.5	0.27	320	0	10	7	-10	100	FKM	E121K0302	4270	486265	14	14	2.0	3510
	3	4.5	0.27	320	0	10	7	-10	100	FKM	E121K0352	2995	481865	8	9	2.0	3510
	3	4.5	0.27	320	0	10	8.5	-10	120	FKM	E121K0352	4270	481000	8	8	2.0	3510
	3	4.5	0.27	320	0	10	10	-10	120	FKM	E121K0352	4270	486265	14	14	2.0	3510
	4	7.5	0.45	480	0	10	4	-10	100	FKM	121K02	2995	481865	8	9	2.0	3510
	4	7.5	0.45	480	0	10	5	-10	120	FKM	121K02	4270	481000	8	8	2.0	3510
	4	7.5	0.45	480	0	10	10	-10	120	FKM	121K02	4270	486265	14	14	2.0	3510
	4	7.5	0.45	480	0	10	4	-10	100	FKM	121K0250	2995	481865	8	9	2.0	3510
	4	7.5	0.45	480	0	10	5	-10	120	FKM	121K0250	4270	481000	8	8	2.0	3510
	4	7.5	0.45	480	0	10	10	-10	120	FKM	121K0250	4270	486265	14	14	2.0	3510
	5	11	0.66	750	0	7	2	-10	100	FKM	121K01	2995	481865	8	9	2.0/14.2	3510
	5	11	0.66	750	0	7	2.8	-10	120	FKM	121K01	4270	481000	8	8	2.0/14.2	3510
	5	11	0.66	750	0	7	5	-10	120	FKM	121K01	4270	486265	14	14	2.0/14.2	3510
	5	11	0.66	750	0	7	2	-10	100	FKM	121K0150	2995	481865	8	9	2.0	3510
	5	11	0.66	750	0	7	2.8	-10	120	FKM	121K0150	4270	481000	8	8	2.0	3510
	5	11	0.66	750	0	7	5	-10	120	FKM	121K0150	4270	486265	14	14	2.0	3510

**Notes:**

1. With manual override



## 2 WAY VALVES



For this page	Port size	Orifice (mm)	Kv (l/min)	MOPD (bar)	Fluid Temp (°C)
From	1/8"	1.5	0.9	2	-10
To	1/4"	5	11	20	120

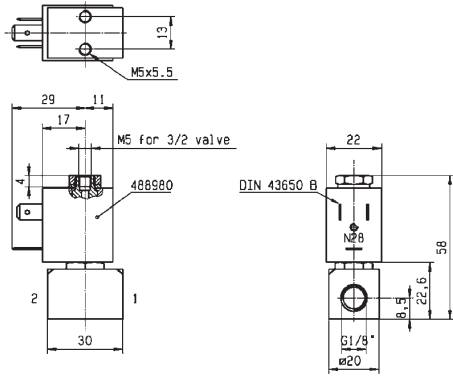

Drawing 3382

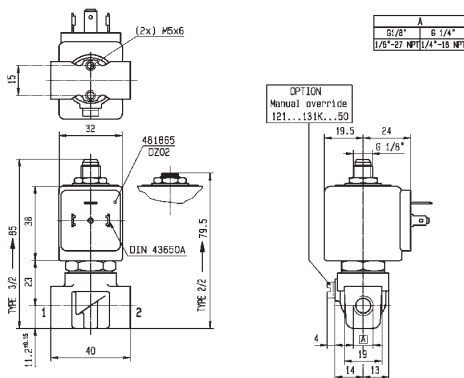

Drawing 3510

**2 WAY VALVES**

# 2/2

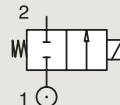
**VALVES FOR WATER AND NEUTRAL LIQUIDS**
**DIRECT OPERATED**
**BRASS**
**PIPE MOUNTING**
**NORMALLY CLOSED**

Port size	Orifice Ø	Flow factors			Operating Pressure Differential			Fluid Temp.		Seat Seal	Valve Ref.	Housing Ref.	Coil Ref.	Power		Coil Group	Dwg. No.
		Kv l/min	KV m³/h	Qn l/min	Min bar	Max(MOPD) AC bar	DC bar	Min °C	Max °C					AC W	DC W		
3/8"	4	7.5	0.45	480	0	10	4	-10	100	FKM	121K3206	2995	481865	8	9	2.0	3551
	4	7.5	0.45	480	0	10	5	-10	120	FKM	121K3206	4270	481000	8	8	2.0	3551
	4	7.5	0.45	480	0	10	10	-10	120	FKM	121K3206	4270	486265	14	14	2.0	3551
	5	11	0.66	750	0	7	2	-10	100	FKM	121K3106	2995	481865	8	9	2.0	3551
	5	11	0.66	750	0	7	2.8	-10	120	FKM	121K3106	4270	481000	8	8	2.0	3551
	5	11	0.66	750	0	7	5	-10	120	FKM	121K3106	4270	486265	14	14	2.0	3551
	6	12	0.72	1100	0	5	1.1	-10	100	FKM	121K3306	2995	481865	8	9	2.0/14.2	3551
	6	12	0.72	1100	0	5	1.5	-10	120	FKM	121K3306	4270	481000	8	8	2.0/14.2	3551
1/2"	6	12	0.72	1100	0	5	3	-10	120	FKM	121K3306	4270	486265	14	14	2.0/14.2	3551
	8.5	25	1.5	1600	0	1.1	0.5	-10	100	FKM	E121K46	2995	481865	8	9	2.0	3427
	8.5	25	1.5	1600	0	2.2	0.5	-10	120	FKM	E121K46	4270	481000	8	8	2.0	3427
	8.5	25	1.5	1600	0	4	1.2	-10	120	FKM	E121K46	4270	486265	14	14	2.0	3427
	11	36	2.16	2500	0	0.7	0.3	-10	100	FKM	E121K45	2995	481865	8	9	2.0	3427
	11	36	2.16	2500	0	1.2	0.35	-10	120	FKM	E121K45	4270	481000	8	8	2.0	3427
	11	36	2.16	2500	0	2.5	0.7	-10	120	FKM	E121K45	4270	486265	14	14	2.0	3427

**Notes:**

1. With manual override

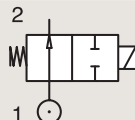
**BRASS**
**PIPE MOUNTING**
**NORMALLY OPEN**

Port size	Orifice Ø	Flow factors			Operating Pressure Differential			Fluid Temp.		Seat Seal	Valve Ref.	Housing Ref.	Coil Ref.	Power		Coil Group	Dwg. No.
		Kv l/min	KV m³/h	Qn l/min	Min bar	Max(MOPD) AC bar	DC bar	Min °C	Max °C					AC W	DC W		
1/4"	2.5	3	0.18	180	0	12	12	-10	100	FKM	122K8306	2995	481865	8	9	2.0	3510
	2.5	3	0.18	180	0	12	12	-10	120	FKM	122K8306	4270	481000	8	8	2.0	3510
	2.5	3	0.18	180	0	12	12	-10	120	FKM	122K8306	4270	486265	14	14	2.0	3510

## 2 WAY VALVES



For this page	Port size	Orifice (mm)	Kv (l/min)	MOPD (bar)	Fluid Temp (°C)
From	1/4"	2.5	3	0.3	-10
To	1/2"	11	36	12	120

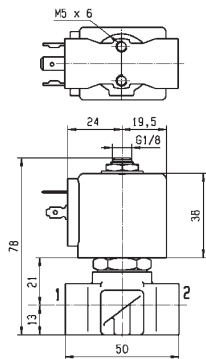

WEIGHT : 215 gr

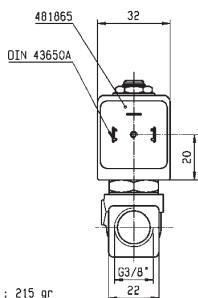

Drawing 3551

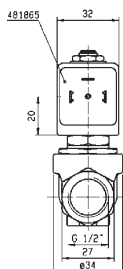
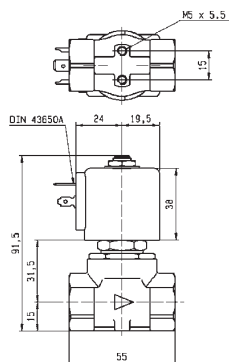

Drawing 3427

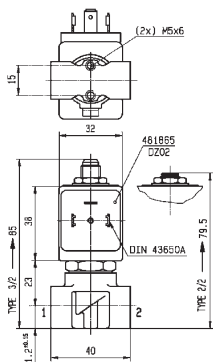

A	
G 3/8"	B 1/4"
G 1/2" - 27 NPT 1/4" - 18 NPT	

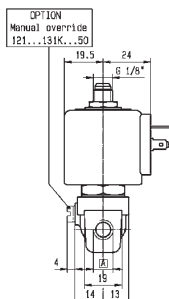

Drawing 3510

## 2 WAY VALVES

# 2/2

## VALVES FOR WATER AND NEUTRAL LIQUIDS

### DIRECT OPERATED

### BRASS

### PIPE MOUNTING

### CONTROL BY ELECTRIC IMPULSE

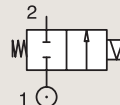

Port size	Orifice Ø	Flow factors			Operating Pressure Differential			Fluid Temp.		Seat Seal	Valve Ref.	Housing Ref.	Coil Ref.	Power		Coil Group	Dwg. No.
		Kv l/min	KV m <sup>3</sup> /h	Qn l/min	Min bar	Max(MOPD) DC bar	Min °C	Max °C	AC W					DC W			
1/4"	5	11	0.66	750	0	5	-	-10	100	FKM	125K01	4269	484990	11	-	4.0	8296
						-	1.5	-10	100	FKM	125K01	4269	485400	-	13	4.0	8296

## 2 WAY VALVES



For this page	Port size	Orifice (mm)	Kv (l/min)	MOPD (bar)	Fluid Temp (°C)
From	1/4"	5	11	1.5	-10
To	1/4"	5	11	5	100

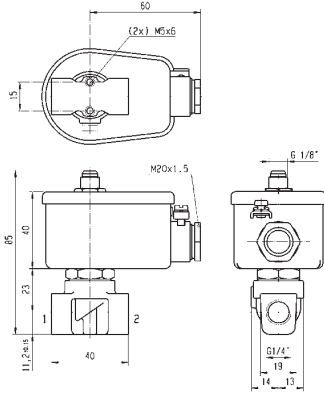

Drawing 8296

## 2 WAY VALVES

# 2/2

## VALVES FOR WATER AND NEUTRAL LIQUIDS

### DIRECT OPERATED

### BRASS

### SUB-BASE MOUNTING

### NORMALLY CLOSED

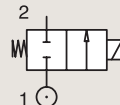

Port size	Orifice Ø mm	Flow factors			Operating Pressure Differential			Fluid Temp.		Seat Seal	Valve Ref.	Housing Ref.	Coil Ref.	Power		Coil Group	Dwg. No.
		Kv l/min	KV m³/h	Qn l/min	Min bar	Max(MOPD) bar	DC bar	Min °C	Max °C					AC W	DC W		
SB	1.5	1.5	0.09	80	0	20	20	-10	100	FKM	E121F4406	2995	481865	8	9	2.0	3509
	1.5	1.5	0.09	80	0	20	20	-10	120	FKM	E121F4406	4270	481000	8	8	2.0	3509
	1.5	1.5	0.09	80	0	20	20	-10	120	FKM	E121F4406	4270	486265	14	14	2.0	3509
	3	4.5	0.27	320	0	10	7	-10	100	FKM	E121F4302	2995	481865	8	9	2.0/3.0	3509
	3	4.5	0.27	320	0	10	8.5	-10	120	FKM	E121F4302	4270	481000	8	8	2.0/3.0	3509
	3	4.5	0.27	320	0	10	10	-10	120	FKM	E121F4302	4270	486265	14	14	2.0/3.0	3509



## 2 WAY VALVES



For this page	Port size	Orifice (mm)	Kv (l/min)	MOPD (bar)	Fluid Temp (°C)
From	5 mm	1.5	1.5	7	-10
To	5 mm	3	4.5	20	120

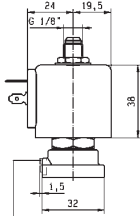
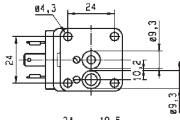

OPTION  
Manual override  
121...131F...50

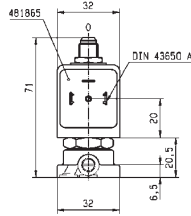

Drawing 3509

## 2 WAY VALVES

# 2/2

## VALVES FOR WATER AND NEUTRAL LIQUIDS

### PILOT OPERATED

#### BRASS

#### PIPE MOUNTING

#### NORMALLY CLOSED

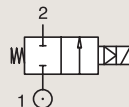

Port size	Orifice Ø	Flow factors			Operating Pressure Differential			Fluid Temp.		Seat Seal	Valve Order Number	Valve Type	Coil Type	Power		Coil Group	Dwg. No.
		Kv l/min	KV m <sup>3</sup> /h	Qn m <sup>3</sup> /h	Min bar	Max(MOPD) DC bar	Min °C	Max °C	AC W					DC W			
3/8"	13	50	3	-	0.1	10	10	-10	140	EPDM	443778W <sub>1</sub>	7321BIH00	481865	8	9	2.0	028
	13	50	3	-	0.1	20	20	-10	90	NBR	443776W	7321BIN00	481865	8	9	2.0	028
	13	50	3	-	0.1	20	20	-10	90	NBR	443777W <sub>2</sub>	7321BIN01	481865	8	9	2.0	028
	13	50	3	-	0.1	20	20	-10	140	FKM	444492W	7321BIV00	481865	8	9	2.0	028
1/2"	13	50	3	-	0.1	10	10	-10	140	EPDM	443781W <sub>1</sub>	7321BAH00	481865	8	9	2.0	028
	13	50	3	-	0.1	20	20	-10	90	NBR	443779W	7321BAN00	481865	8	9	2.0	028
	13	50	3	-	0.1	20	20	-10	90	NBR	443780W <sub>2</sub>	7321BAN01	481865	8	9	2.0	028
	13	50	3	-	0.1	20	20	-10	140	FKM	444494W	7321BAV00	481865	8	9	2.0	028
3/4"	20	140	8.4	-	0.1	10	10	-10	140	EPDM	443785W <sub>1</sub>	7321BCH00	481865	8	9	2.0	057
	20	140	8.4	-	0.1	20	20	-10	90	NBR	443782W	7321BCN00	481865	8	9	2.0	057
	20	140	8.4	-	0.1	10	10	-10	90	NBR	443783W <sub>2</sub>	7321BCN01	481865	8	9	2.0	057
	20	140	8.4	-	0.1	20	20	-10	140	FKM	444497W	7321BCV00	481865	8	9	2.0	057
1"	25	160	9.6	-	0.1	10	10	-10	140	EPDM	443789W <sub>1</sub>	7321BDH00	481865	8	9	2.0	057
	25	160	9.6	-	0.1	20	20	-10	90	NBR	443786W	7321BDN00	481865	8	9	2.0	057
	25	160	9.6	-	0.1	10	10	-10	90	NBR	443787W <sub>2</sub>	7321BDN01	481865	8	9	2.0	057
	25	160	9.6	-	0.1	20	20	-10	140	FKM	443804W	7321BDV00	481865	8	9	2.0	057

#### Notes:

1. Maximum pressure for steam: 4 Bar (140°C)

2. With manual override

Important: pressure vessels included in this page are supplied with the standard 2995 housing integrated.

## 2 WAY VALVES



For this page	Port size	Orifice (mm)	Kv (l/min)	MOPD (bar)	Fluid Temp (°C)
From	3/8"	13	50	10	-10
To	1"	25	160	20	140

G / NPT	A		B		C	
	mm	inch	mm	inch	mm	inch
3/8"	89	2.71	99.5	3.91	40	1.57
1/2"	72	2.83	101.5	3.99	40	1.57

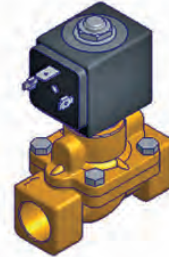
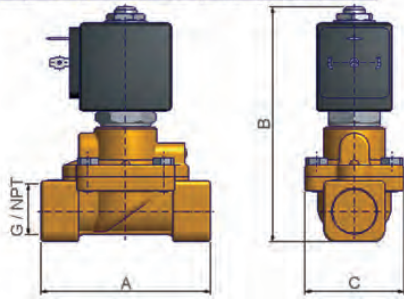

Drawing 028

G / NPT	A		B		C	
	mm	inch	mm	inch	mm	inch
3/4"	100	3.83	107	4.21	65	2.55
1"	104	4.09	112.5	4.42	65	2.55

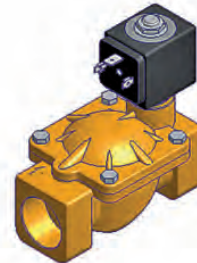
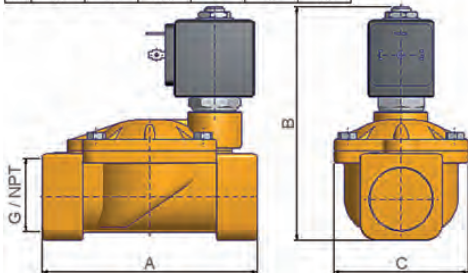

Drawing 057

## 2 WAY VALVES

# 2/2

## VALVES FOR WATER AND NEUTRAL LIQUIDS

### PILOT OPERATED

#### BRASS

#### PIPE MOUNTING

#### NORMALLY CLOSED

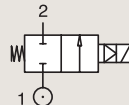

Port size	Orifice Ø	Flow factors			Operating Pressure Differential			Fluid Temp.		Seat Seal	Valve Order Number	Valve Type	Coil Type	Power		Coil Group	Dwg. No.
		Kv l/min	KV m <sup>3</sup> /h	Qn m <sup>3</sup> /h	Min bar	Max(MOPD) AC bar	DC bar	Min °C	Max °C					AC W	DC W		
1 1/4"	35	420	25.2	-	0.1	10	10	-10	140	EPDM	443793W <sub>1</sub>	7321BEH00	481865	8	9	2.0	058
	35	420	25.2	-	0.1	10	10	-10	90	NBR	443790W	7321BEN00	481865	8	9	2.0	058
	35	420	25.2	-	0.1	5	5	-10	90	NBR	443791W <sub>2</sub>	7321BEN01	481865	8	9	2.0	058
1 1/2"	40	500	30	-	0.1	10	10	-10	140	EPDM	443797W <sub>1</sub>	7321BFH00	481865	8	9	2.0	058
	40	500	30	-	0.1	10	10	-10	90	NBR	443794W	7321BFN00	481865	8	9	2.0	058
	40	500	30	-	0.1	5	5	-10	90	NBR	443795W <sub>2</sub>	7321BFN01	481865	8	9	2.0	058
2"	50	620	37.2	-	0.1	10	10	-10	140	EPDM	443801W <sub>1</sub>	7321BGH00	481865	8	9	2.0	058
	50	620	37.2	-	0.1	10	10	-10	90	NBR	443798W	7321BGN00	481865	8	9	2.0	058
	50	620	37.2	-	0.1	5	5	-10	90	NBR	443799W <sub>2</sub>	7321BGN01	481865	8	9	2.0	058

#### Notes:

1. Maximum pressure for steam: 4 Bar (140°C)

2. With manual override

Important: pressure vessels included in this page are supplied with the standard 2995 housing integrated.

## 2 WAY VALVES



For this page	Port size	Orifice (mm)	Kv (l/min)	MOPD (bar)	Fluid Temp (°C)
From	1 1/4"	35	420	5	-10
To	2"	50	620	10	140

G	A		B		C	
	mm	inch	mm	inch	mm	inch
1-1/4"	145	5.70	134	5.27	102	4.01
1-1/2"	145	5.70	134	5.27	102	4.01
2"	173	6.81	148	5.82	118	4.64

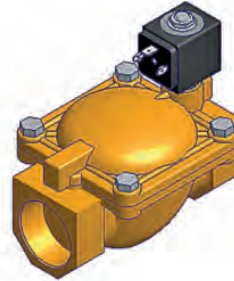
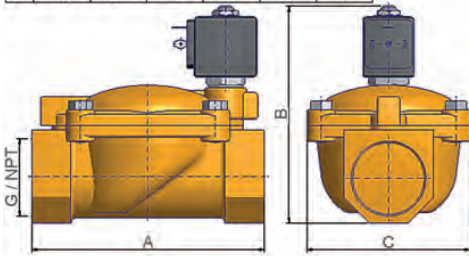

Drawing 058

## 2 WAY VALVES

# 2/2

## VALVES FOR WATER AND NEUTRAL LIQUIDS

### PILOT OPERATED

### BRASS

### PIPE MOUNTING

### NORMALLY CLOSED

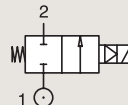

Port size (BSP)	Orifice Ø mm	Flow factors			Operating Pressure Differential			Fluid Temp.		Seat Seal	Valve Ref.	Housing Ref.	Coil Ref.	Power		Coil Group	Dwg. No.
		Kv l/min	KV m <sup>3</sup> /h	Qn m <sup>3</sup> /h	Min bar	Max(MOPD) AC bar	DC bar	Min °C	Max °C					AC W	DC W		
1/4"	11	28	1.68	1800	0.2	10	3	-10	100	NBR	E321K10	2995	481865	8	9	2.0	3429
	11	28	1.68	1800	0.2	10	4	-10	100	NBR	E321K10	4270	481000	8	8	2.0	3429
	12	30	1.8	2150	0.3	10	10	-10	100	NBR	321K31	8993	481180	4	5	1.1	7093
	12	30	1.8	2150	0.3	10	7	-10	75	NBR	321K31	8993	488980	2	2.5	1.1	7093
	12	32	1.92	2150	0.3	12	12	-10	100	FKM	321K4106	2995	481865	8	9	2.1/3.0	7094
	12	32	1.92	2150	0.3	12	12	-10	120	FKM	321K4106	4270	481000	8	8	2.1/3.0	7094
3/8"	11	36	2.16	2500	0.2	10	4	-10	100	NBR	E321K13	4270	481000	8	8	2.0	3429
	11	36	2.16	2500	0.2	10	10	-10	100	NBR	E321K13	4270	486265	14	14	2.0	3429
	12	45	2.7	3050	0.3	10	10	-10	100	NBR	321K33	8993	481180	4	5	1.1	7093
	12	45	2.7	3050	0.3	10	7	-10	75	NBR	321K33	8993	488980	2	2.5	1.1	7093
	12	45	2.7	3050	0.3	12	12	-10	100	FKM	321K4306	2995	481865	8	9	2.1/3.0	7094
	12	45	2.7	3050	0.3	12	12	-10	120	FKM	321K4306	4270	481000	8	8	2.1/3.0	7094

## 2 WAY VALVES



For this page	Port size	Orifice (mm)	Kv (l/min)	MOPD (bar)	Fluid Temp (°C)
From	1/4"	11	28	3	-10
To	3/8"	12	45	12	120

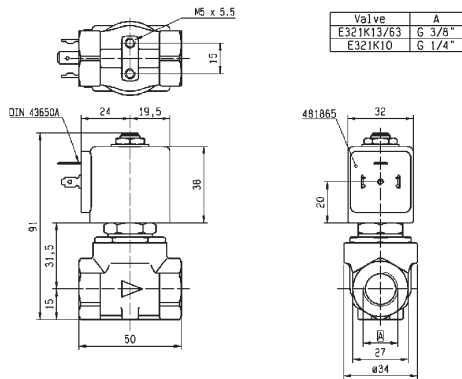

Drawing 3429

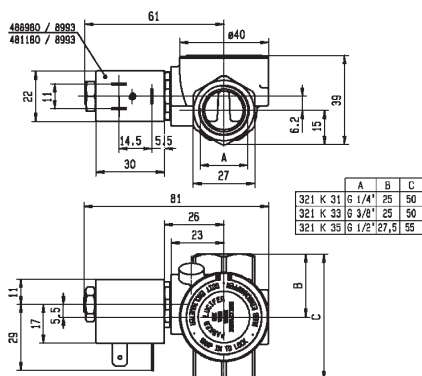

Drawing 7093

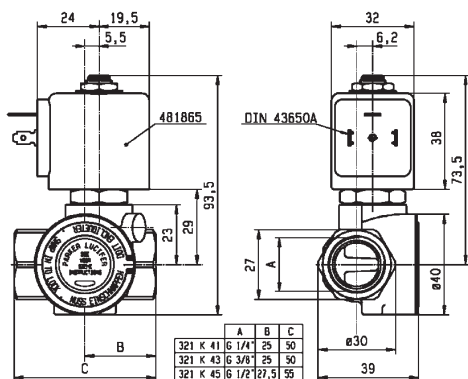

Drawing 7094

## 2 WAY VALVES

# 2/2

## VALVES FOR WATER AND NEUTRAL LIQUIDS

### PILOT OPERATED

#### BRASS

#### PIPE MOUNTING

#### NORMALLY CLOSED

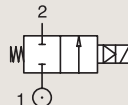

Port size (BSP)	Orifice Ø mm	Flow factors			Operating Pressure Differential			Fluid Temp.		Seat Seal	Valve Ref.	Housing Ref.	Coil Ref.	Power		Coil Group	Dwg. No.
		Kv l/min	KV m³/h	Qn m³/h	Min bar	AC bar	DC bar	Min °C	Max °C					AC W	DC W		
1/2"	11	36	2.16	2500	0.2	10	3	-10	100	NBR	E321K15	2995	481865	8	9	2.0	3427
	11	36	2.16	2500	0.2	10	10	-10	120	NBR	E321K15	4270	486265	14	14	2.0	3427
	11	36	2.16	2500	0.2	10	3	-10	100	FKM	E321K25	2995	481865	8	9	2.0	3427
	11	36	2.16	2500	0.2	4	4	-10	65	FKM	E321K25	-	492070	9	8	2.0	3427
	12	50	3	3400	0.3	10	10	-10	100	NBR	321K35	8993	481180	4	5	1.1	7093
	12	50	3	3400	0.3	10	7	-10	75	NBR	321K35	8993	488980	2	2.5	1.1	7093
	12	50	3	3400	0.3	12	12	-10	100	FKM	321K4506	2995	481865	8	9	2.1/3.0	7094
	12	50	3	3400	0.3	12	12	-10	120	FKM	321K4506	4270	481000	8	8	2.1/3.0	7094
	12	50	3	3400	0.3	12	12	-10	100	FKM	321K4556 <sub>1</sub>	2995	481865	8	9	2.1/3.0	7094
	12	50	3	3400	0.3	12	12	-10	120	FKM	321K4556 <sub>1</sub>	4270	481000	8	8	2.1/3.0	7094

**Notes:**

1. With manual override

## 2 WAY VALVES



For this page	Port size	Orifice (mm)	Kv (l/min)	MOPD (bar)	Fluid Temp (°C)
From	1/2"	11	36	3	-10
To	1/2"	12	50	12	120

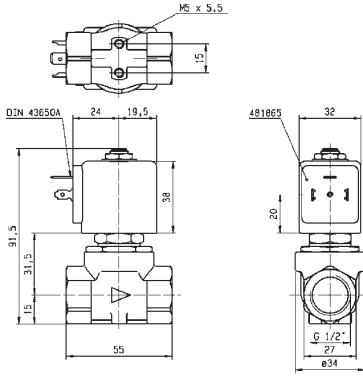

Drawing 3427

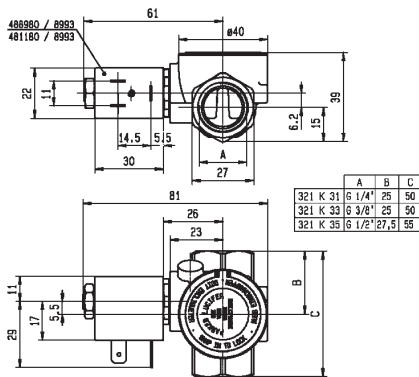

Drawing 7093

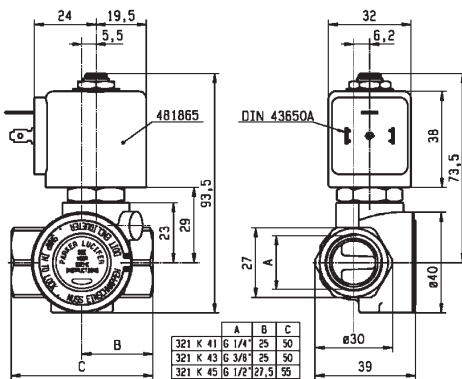

Drawing 7094

## 2 WAY VALVES

# 2/2

## VALVES FOR WATER AND NEUTRAL LIQUIDS

### PILOT OPERATED

#### BRASS

#### PIPE MOUNTING

#### NORMALLY CLOSED

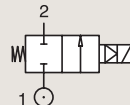

Port size (BSP)	Orifice Ø mm	Flow factors			Operating Pressure Differential			Fluid Temp.		Seat Seal	Valve Ref.	Housing Ref.	Coil Ref.	Power		Coil Group	Dwg. No.
		Kv l/min	KV m³/h	Qn m³/h	Min bar	AC bar	DC bar	Min °C	Max °C					AC W	DC W		
3/4"	18	100	6	9400	0.3	10	10	-10	100	NBR	321K36	8993	481180	4	5	1.1	7097
	18	100	6	9400	0.3	10	7	-10	75	NBR	321K36	8993	488980	2	2.5	1.1	7097
	18	100	6	9400	0.3	12	12	-10	100	FKM	321K4606	2995	481865	8	9	2.1/3.0	7099
	18	100	6	9400	0.3	12	12	-10	120	FKM	321K4606	4270	481000	8	8	2.1/3.0	7099
	18	100	6	9400	0.3	12	12	-10	100	FKM	321K4656 <sub>1</sub>	2995	481865	8	9	2.1/3.0	7099
	18	100	6	9400	0.3	12	12	-10	120	FKM	321K4656 <sub>1</sub>	4270	481000	8	8	2.1/3.0	7099
	20	135	8.1	9500	0.3	16	16	-10	100	NBR	E321G36	2995	481865	8	9	2.0	3442
	20	135	8.1	9500	0.3	16	16	-10	100	NBR	E321G36	4270	481000	8	8	2.0	3442

**Notes:**

1. With manual override

## 2 WAY VALVES



For this page	Port size	Orifice (mm)	Kv (l/min)	MOPD (bar)	Fluid Temp (°C)
From	3/4"	18	100	7	-10
To	3/4"	20	135	16	120

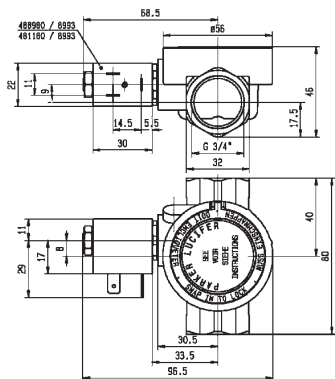

Drawing 7097

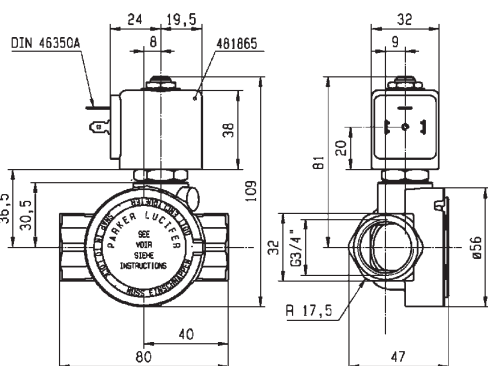

Drawing 7099

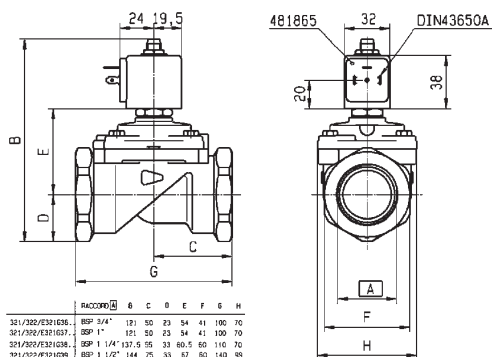

Drawing 3442

Part No.	A	B	C	D	E	F	G	H
311/322/E321036..	80P 3/4"	193	50	23	54	41	100	70
311/332/E321037..	80P 1"	121	50	23	54	41	100	70
311/332/E321038..	80P 1 1/4"	137.5	55	33	60.5	60	110	70
311/332/E321039..	80P 1 1/2"	144	75	33	67	60	140	99
321/336A/42061..	148P 1 7/8"	144	75	33	67	60	140	99
US21/A020640..	80P 2"	158.5	80	41.5	73	75	150	99



**2 WAY VALVES**

# 2/2

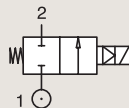
**VALVES FOR WATER AND NEUTRAL LIQUIDS**
**PILOT OPERATED**
**BRASS**
**PIPE MOUNTING**
**NORMALLY CLOSED**

Port size (BSP)	Orifice Ø mm	Flow factors			Operating Pressure Differential			Fluid Temp. °C		Seat Seal	Valve Ref.	Housing Ref.	Coil Ref.	Power		Coil Group	Dwg. No.
		Kv l/min	KV m³/h	Qn m³/h	Min bar	Max(MOPD) AC bar	DC bar	Min °C	Max °C					AC W	DC W		
1"	18	110	6.6	10150	0.3	10	10	-10	100	NBR	321K37	8993	481180	4	5	1.1	7098
	18	110	6.6	10150	0.3	10	7	-10	75	NBR	321K37	8993	488980	2	2.5	1.1	7098
	18	110	6.6	10150	0.3	12	12	-10	100	FKM	321K4706	2995	481865	8	9	2.1/3.0	7100
	18	110	6.6	10150	0.3	12	12	-10	120	FKM	321K4706	4270	481000	8	8	2.1/3.0	7100
	18	110	6.6	10150	0.3	12	12	-10	100	FKM	321K4756 <sub>2</sub>	2995	481865	8	9	2.1/3.0	7100
	18	110	6.6	10150	0.3	12	12	-10	120	FKM	321K4756 <sub>2</sub>	4270	481000	8	8	2.1/3.0	7100
1 1/4"	25	180	10.8	14000	0.3	16	16	-10	100	NBR	E321G37	2995	481865	8	9	2.0	3442
	25	180	10.8	14000	0.3	16	16	-10	100	NBR	E321G37	4270	481000	8	8	2.0	3442
1 1/4"	28	270	16.2	18000	0.3	16	16	-10	100	NBR	E321G38	2995	481865	8	9	2.0	3442
	28	270	16.2	18000	0.3	16	16	-10	100	NBR	E321G38	4270	481000	8	8	2.0	3442
1 1/2"	40	420	25.2	31500	0.3	16	7	-10	100	NBR	E321G39 <sub>1</sub>	2995	481865	8	9	2.0	3442
	40	420	25.2	31500	0.3	16	8.5	-10	100	NBR	E321G39 <sub>1</sub>	4270	481000	8	8	2.0	3442
2"	40	420	25.2	31500	0.3	16	16	-10	100	NBR	E321G39 <sub>1</sub>	4270	486265	14	14	2.0	3442
	40	540	32.4	40000	0.3	16	7	-10	100	NBR	E321G40 <sub>1</sub>	2995	481865	8	9	2.0	3442
	40	540	32.4	40000	0.3	16	8.5	-10	100	NBR	E321G40 <sub>1</sub>	4270	481000	8	8	2.0	3442
40	540	32.4	40000	0.3	16	16	-10	100	NBR	E321G40 <sub>1</sub>	4270	486265	14	14	2.0	3442	

**Notes:**

1.Pilot seat disc in synthetic Ruby

2.With manual override

## 2 WAY VALVES



For this page	Port size	Orifice (mm)	Kv (l/min)	MOPD (bar)	Fluid Temp (°C)
From	1"	18	110	7	-10
To	2"	40	540	16	120

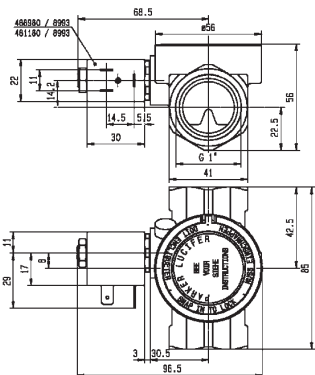

Drawing 7098

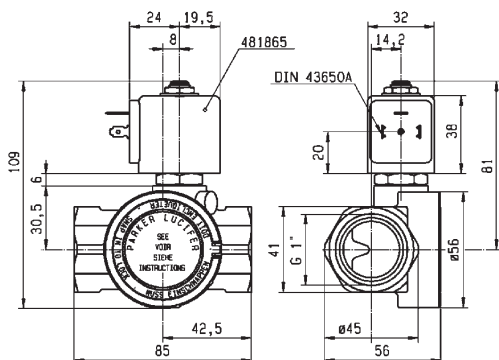

Drawing 7100

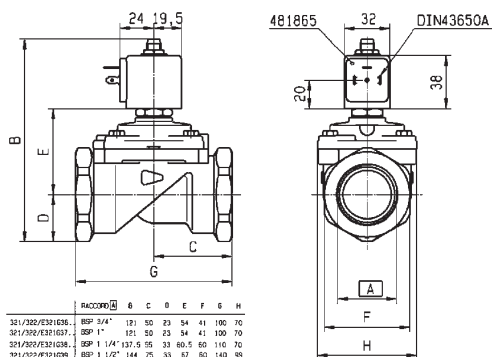

Drawing 3442

Part No.	Series	A	B	C	D	E	F	G	H
311/302/E321038..	BBP 3/4"	193	50	23	54	41	100	70	
311/302/E321037..	BBP 1"	121	50	23	54	41	100	70	
311/302/E321038..	BBP 1 1/4"	137.5	55	33	60.5	60	110	70	
311/302/E321039..	BBP 1 1/2"	144	75	33	67	60	140	99	
311/302/E321040..	BBP 2"	144	75	33	67	60	140	99	
US21/A02040..	BBP 2"	158.5	80	41.5	73	75	150	99	



## 2 WAY VALVES

# 2/2

## VALVES FOR WATER AND NEUTRAL LIQUIDS

### PILOT OPERATED

### BRASS

### PIPE MOUNTING

### NORMALLY OPEN

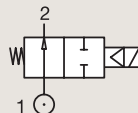

Port size	Orifice Ø	Flow factors			Operating Pressure Differential			Fluid Temp.		Seat Seal	Valve Order Number	Valve Type	Coil Type	Power		Coil Group	Dwg. No.
		Kv l/min	KV m <sup>3</sup> /h	Qn m <sup>3</sup> /h	Min bar	Max(MOPD) AC bar	DC bar	Min °C	Max °C					AC W	DC W		
3/8"	13	50	3	-	0.1	10	10	-10	140	EPDM	444600W	7322BIH00	481865	8	9	2.0	060
	13	50	3	-	0.1	20	20	-10	90	NBR	443805W	7322BIN00	481865	8	9	2.0	060
	13	50	3	-	0.1	20	20	-10	140	FKM	444499W	7322BIV00	481865	8	9	2.0	060
1/2"	13	50	3	-	0.1	10	10	-10	140	EPDM	444601W	7322BAH00	481865	8	9	2.0	060
	13	50	3	-	0.1	20	20	-10	90	NBR	443806W	7322BAN00	481865	8	9	2.0	060
	13	50	3	-	0.1	20	20	-10	140	FKM	444500W	7322BAV00	481865	8	9	2.0	060
3/4"	20	140	8.4	-	0.1	10	10	-10	140	EPDM	444602W	7322BCH00	481865	8	9	2.0	061
	20	140	8.4	-	0.1	20	20	-10	90	NBR	443807W	7322BCN00	481865	8	9	2.0	061
	20	140	8.4	-	0.1	20	20	-10	140	FKM	444501W	7322BCV00	481865	8	9	2.0	061
1"	25	160	9.6	-	0.1	10	10	-10	140	EPDM	444603W	7322BDH00	481865	8	9	2.0	061
	25	160	9.6	-	0.1	20	20	-10	90	NBR	443808W	7322BDN00	481865	8	9	2.0	061
	25	160	9.6	-	0.1	20	20	-10	140	FKM	444502W	7322BDV00	481865	8	9	2.0	061
1 1/4"	35	420	25.2	-	0.1	10	10	-10	140	EPDM	444576W	7322BEH00	481865	8	9	2.0	062
	35	420	25.2	-	0.1	10	10	-10	90	NBR	443809W	7322BEN00	481865	8	9	2.0	062
1 1/2"	40	500	30	-	0.1	10	10	-10	140	EPDM	444604W	7322BFH00	481865	8	9	2.0	062
	40	500	30	-	0.1	10	10	-10	90	NBR	443810W	7322BFN00	481865	8	9	2.0	062
2"	50	620	37.2	-	0.1	10	10	-10	140	EPDM	444605W	7322BGH00	481865	8	9	2.0	062
	50	620	37.2	-	0.1	10	10	-10	90	NBR	443811W	7322BGN00	481865	8	9	2.0	062
2 1/2"	65	1100	66	-	0.2	10	10	-10	90	NBR	444513W	7322BLN06	481865	8	9	2.0	063
3"	75	1334	80	-	0.2	10	10	-10	90	NBR	444503W	7322BMN06	481865	8	9	2.0	063

Important: pressure vessels included in this page are supplied with the standard 2995 housing integrated.

G	A		B		C	
	mm	inch	mm	inch	mm	inch
1-1/4"	143	5.70	144.5	5.68	102	4.01
1-1/2"	145	--	134	--	102	--
2"	173	--	148	--	118	--

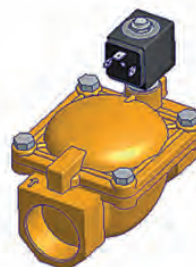
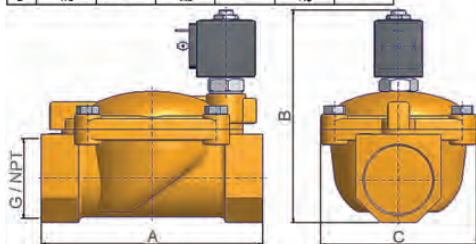

Drawing 062

## 2 WAY VALVES



For this page	Port size	Orifice (mm)	Kv (l/min)	MOPD (bar)	Fluid Temp (°C)
From	3/8"	13	50	10	-10
To	3"	75	1334	20	140

G	A		B		C	
	mm	inch	mm	inch	mm	inch
3/8"	89	2.71	110	4.33	40	1.57
1/2"	72	2.83	112	4.41	40	1.57

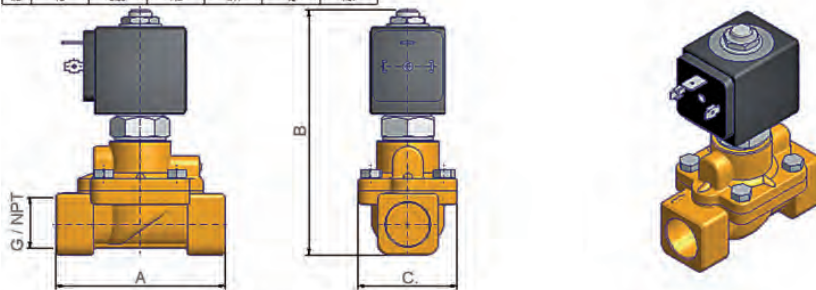

Drawing 060

G	A		B		C	
	mm	inch	mm	inch	mm	inch
3/4"	100	3.83	117.5	4.62	65	2.55
1"	104	4.09	123	4.84	65	2.55

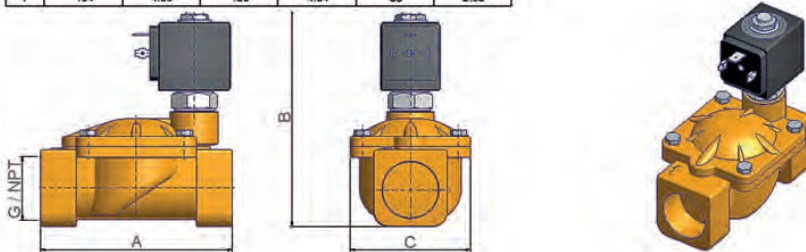

Drawing 061

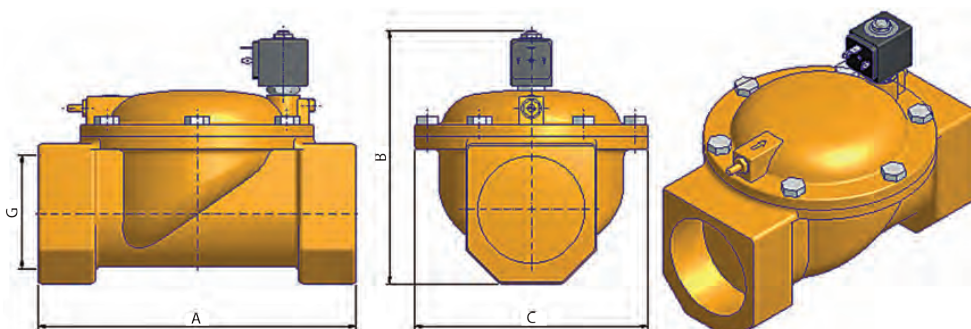

Drawing 063

## 2 WAY VALVES

# 2/2

## VALVES FOR WATER AND NEUTRAL LIQUIDS PILOT OPERATED

### BRASS

### PIPE MOUNTING

### NORMALLY OPEN

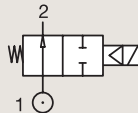

Port size	Orifice Ø	Flow factors			Operating Pressure Differential			Fluid Temp.		Seat Seal	Valve Ref.	Housing Ref.	Coil Ref.	Power		Coil Group	Dwg. No.
		Kv l/min	KV m³/h	Qn l/min	Min bar	Max(MOPD) AC bar	DC bar	Min °C	Max °C					AC W	DC W		
1/4"	12	32	1.92	2150	0.3	12	12	-10	100	FKM	322K4106	2995	481865	8	9	2.1	7094
	12	32	1.92	2150	0.3	12	12	-10	120	FKM	322K4106	4270	481000	8	8	2.1	7094
3/8"	12	45	2.7	3050	0.3	12	12	-10	100	FKM	322K4306	2995	481865	8	9	2.1	7094
	12	45	2.7	3050	0.3	12	12	-10	120	FKM	322K4306	4270	481000	8	8	2.1	7094
1/2"	12	50	3	3400	0.3	12	12	-10	100	FKM	322K4506	2995	481865	8	9	2.1	7094
	12	50	3	3400	0.3	12	12	-10	120	FKM	322K4506	4270	481000	8	8	2.1	7094
3/4"	15	60	3.6	3890	0.3	15	15	-10	100	NBR	322G75	2995	481865	8	9	2.1	3522
	15	60	3.6	3890	0.3	15	15	-10	100	NBR	322G75	4270	481000	8	8	2.1	3522
	18	100	6	9400	0.3	12	12	-10	100	FKM	322K4606	2995	481865	8	9	2.1	7099
	18	100	6	9400	0.3	12	12	-10	120	FKM	322K4606	4270	481000	8	8	2.1	7099
3/4"	20	135	8.1	9500	0.3	16	16	-10	100	NBR	322G36	2995	481865	8	9	2.1	3442
	20	135	8.1	9500	0.3	16	16	-10	100	NBR	322G36	4270	481000	8	8	2.1	3442

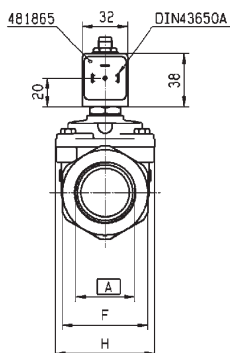
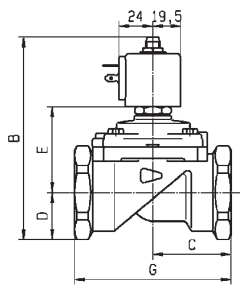

Part No.	Port Size	Orifice	Qn	Q1	Q2	Q3	Q4	Q5	Q6	Q7	Q8	Q9	Q10
321/322/E321036	BSP 1/4"	12	30	33	34	41	100	70					
321/322/E321037	BSP 1"	121	50	23	34	41	100	70					
321/322/E321038	BSP 1 1/4"	137.5	55	33	60.5	60	110	70					
321/322/E321039	BSP 1 1/2"	144	75	33	67	60	140	99					
321/322/E321040	1 1/2"	144	75	33	67	60	140	99					
US21/A020640	BSP 2"	158.5	80	41.5	73	75	150	99					

Drawing 3442



## 2 WAY VALVES



For this page	Port size	Orifice (mm)	Kv (l/min)	MOPD (bar)	Fluid Temp (°C)
From	1/4"	12	32	12	-10
To	3/4"	20	135	16	120

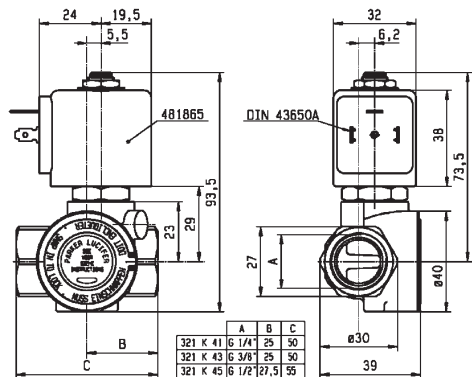

Drawing 7094

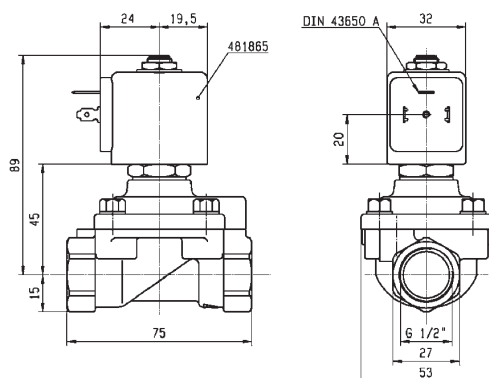

Drawing 3522

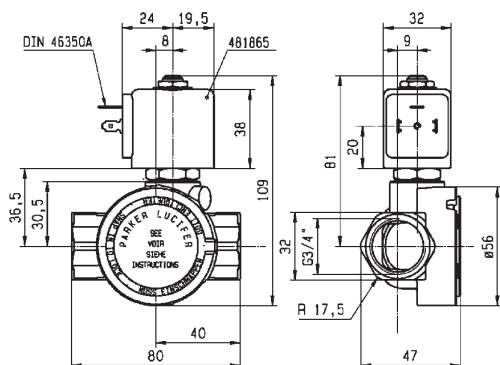

Drawing 7099



## 2 WAY VALVES

# 2/2

## VALVES FOR WATER AND NEUTRAL LIQUIDS

### PILOT OPERATED

#### BRASS

#### PIPE MOUNTING

#### NORMALLY OPEN

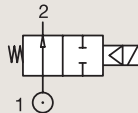

Port size	Orifice Ø	Flow factors			Operating Pressure Differential			Fluid Temp.		Seat Seal	Valve Ref.	Housing Ref.	Coil Ref.	Power		Coil Group	Dwg. No.
		Kv l/min	KV m <sup>3</sup> /h	Qn l/min	Min bar	Max(MOPD) AC bar	DC bar	Min °C	Max °C					AC W	DC W		
1"	18	110	6.6	10150	0.3	12	12	-10	100	FKM	322K4706	2995	481865	8	9	2.0	7100
	18	110	6.6	10150	0.3	12	12	-10	120	FKM	322K4706	4270	481000	8	8	2.0	7100
	25	180	10.8	14000	0.3	16	16	-10	100	NBR	322G37	2995	481865	8	9	2.1	3442
	25	180	10.8	14000	0.3	16	16	-10	100	NBR	322G37	4270	481000	8	8	2.1	3442
1 1/2"	40	420	25.2	31500	0.3	12	12	-10	100	NBR	322G39	2995	481865	8	9	2.1	3442
	40	420	25.2	31500	0.3	12	12	-10	100	NBR	322G39	4270	481000	8	8	2.1	3442

#### BRASS

#### SUB-BASE MOUNTING

#### NORMALLY CLOSED

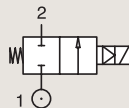

Port size	Orifice Ø	Flow factors			Operating Pressure Differential			Fluid Temp.		Seat Seal	Valve Ref.	Housing Ref.	Coil Ref.	Power		Coil Group	Dwg. No.
		Kv l/min	KV m <sup>3</sup> /h	Qn l/min	Min bar	Max(MOPD) AC bar	DC bar	Min °C	Max °C					AC W	DC W		
SB	14	45	2.7	2100	0.3	40	25	-10	100	NBR	E321F32	2995	481865	8	9	2.0	3520
	14	45	2.7	2100	0.3	40	30	-10	100	NBR	E321F32	4270	481000	8	8	2.0	3520
	14	45	2.7	2100	0.3	40	40	-10	100	NBR	E321F32	4270	486265	14	14	2.0	3520

**Notes:**

1. Pilot seat disc in synthetic Ruby



## 2 WAY VALVES



For this page	Port size	Orifice (mm)	Kv (l/min)	MOPD (bar)	Fluid Temp (°C)
From	14 mm	14	45	12	-10
To	1 1/2"	40	420	40	120

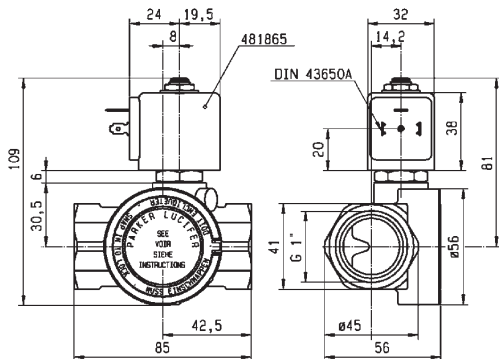

Drawing 7100

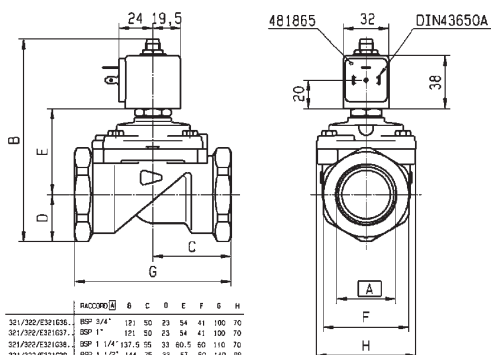

PACORD	B	C	D	E	F	G	H	
311/322/E31636..	BSP 3/4"	121	50	23	54	41	100	70
311/332/E321637..	BSP 1"	121	50	23	54	41	100	70
311/330/E31638..	BSP 1 1/4"	137.5	55	33	60.5	60	110	70
321/322/E31639..	BSP 1 1/2"	144	75	33	67	60	140	95
3210296/G2967	UNF 1 7/8"	144	75	33	67	60	140	95
U321/0292640..	BSP 2"	158.5	80	41.5	73	75	150	99



Drawing 3442

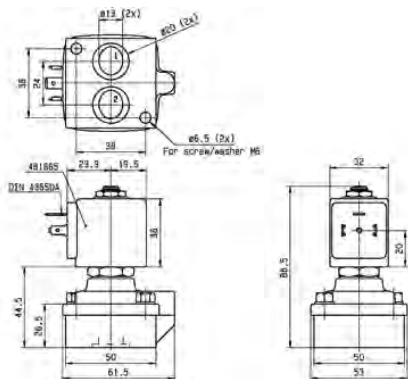

Drawing 3520





## 2 WAY VALVES

### ANTI WATER HAMMER VALVES



Water

# 2/2

Actuation	Body	Function	Port Size	Orifice (mm)	Flow Factor Kv(l/min)	MOPD (bar)	Max Fluid Temp. (°C)	Page Parker Valves	
Magnalift	Brass/Pipe Mounting	Normally Closed	1"	15 to 25	170	10	140	90	
Pilot Operated	Brass/Pipe Mounting	Normally Closed	1/4"	12	32	12	120	94	
			3/8"	12	45	12	120	94	
			1/2"	12	50	12	120	94	
			3/4"	18 to 20	135	16	120	94	
			1"	18 to 25	180	16	120	92 and 96	
			1 1/4"	28 to 35	420	16	100	92 and 96	
			1 1/2"	40	500	16	100	92 and 96	
			2"	40 to 50	620	16	100	92 and 96	
			2 1/2"	65	1100	10	90	92	
			3"	75	1334	10	90	92	
			Normally Open	3/4"	20	135	16	100	98
				1"	25	180	16	100	98
		1 1/4"		28	270	16	100	98	
			1 1/2"	40	425	12	100	98	
			2"	40	540	12	100	98	

## 2 WAY VALVES

# 2/2

## ANTI WATER HAMMER VALVES

### MAGNALIFT



Commercial Equipment

### BRASS

### PIPE MOUNTING

### NORMALLY CLOSED

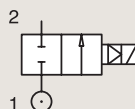

Port size	Orifice Ø	Flow factors			Operating Pressure Differential			Fluid Temp.		Seat Seal	Valve Ref.	Housing Ref.	Coil Ref.	Power		Coil Group	Dwg. No.
		Kv l/min	KV m <sup>3</sup> /h	Qn l/min	Min bar	Max(MOPD) AC bar	DC bar	Min °C	Max °C					AC W	DC W		
1"	15	80	4.8	6000	0	-	10	-10	100	NBR	221G1731 <sup>12</sup>	2995	481865	-	9	2.1	3445
	15	80	4.8	6000	0	10	10	-10	65	NBR	221G1731 <sup>12</sup>	-	492070	9	8	2.1	3445
	15	80	4.8	6000	0	10	10	-10	75	NBR	221G1731 <sup>12</sup>	-	492190	11	9	2.1	3445
	25	160	9.6	-	0	10	-	0	100	EPDM	221G2103	2995	481865	8	-	2.0	3448
	25	160	9.6	-	0	10	-	0	120	EPDM	221G2103	4270	481000	8	-	2.0	3448
	25	160	9.6	-	0	10	10	0	120	EPDM	221G2103	4270	486265	14	14	2.0	3448
	25	160	9.6	-	0	4	4	0	140	EPDM	221G2103	2995	492425	14	14	2.0	3448
	25	170	10.2	14000	0	-	10	-25	100	NBR	221G2131 <sup>12</sup>	2995	481865	-	9	2.1	3448
	25	170	10.2	14000	0	10	10	-25	40	NBR	221G2131 <sup>12</sup>	-	492070	9	8	2.1	3448
	25	170	10.2	14000	0	10	10	-25	40	NBR	221G2131 <sup>12</sup>	-	492190	11	9	2.1	3448

**Notes:**

1. Valves with model number ending in 30 or 31 are only compatible with explosion proof electrical parts shown, or with group 2.1 coils only in DC voltage.

2. With 4 position selector for controlled closure rate

## 2 WAY VALVES



For this page	Port size	Orifice (mm)	Kv (l/min)	MOPD (bar)	Fluid Temp (°C)
From	1"	15	80	4	-25
To	1"	25	170	10	140

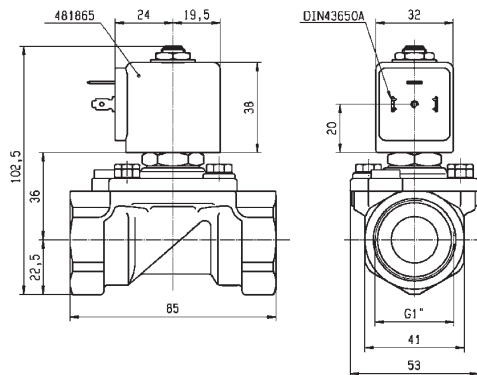

Drawing 3445

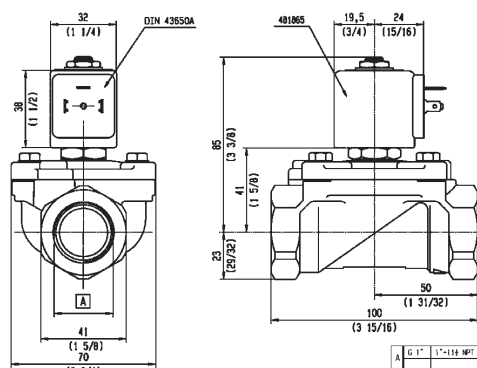

Drawing 3448

## 2 WAY VALVES

# 2/2

## ANTI WATER HAMMER VALVES

### PILOT OPERATED

### BRASS

### PIPE MOUNTING

### NORMALLY CLOSED

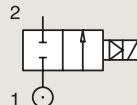

Port size	Orifice Ø	Flow factors			Operating Pressure Differential Max(MOPD)			Fluid Temp.		Seat Seal	Valve Order Number	Valve Type	Coil Type	Power		Coil Group	Dwg. No.
		Kv l/min	KV m³/h	Qn m³/h	Min bar	AC bar	DC bar	Min °C	Max °C					AC W	DC W		
3/4"	20	140	8.4	-	0.1	10	10	-10	90	NBR	443784W <sub>1</sub>	7321BCN02	481865	8	9	2.0	057
1"	25	160	9.6	-	0.1	10	10	-10	90	NBR	443788W <sub>1</sub>	7321BDN02	481865	8	9	2.0	057
1 1/4"	35	420	25.2	-	0.1	5	5	-10	90	NBR	443792W <sub>1</sub>	7321BEN02	481865	8	9	2.0	058
1 1/2"	40	500	30	-	0.1	5	5	-10	90	NBR	443796W <sub>1</sub>	7321BFN02	481865	8	9	2.0	058
2"	50	620	37.2	-	0.1	5	5	-10	90	NBR	443800W <sub>1</sub>	7321BGN02	481865	8	9	2.0	058
2 1/2"	65	1100	66	-	0.2	10	10	-10	90	NBR	443802W <sub>1</sub>	7321BLN02	481865	8	9	2.0	059
3"	75	1334	80	-	0.2	10	10	-10	90	NBR	443803W <sub>1</sub>	7321BMN02	481865	8	9	2.0	059

**Notes:**

1. With manual override

Important: pressure vessels included in this page are supplied with the standard 2995 housing integrated.

## 2 WAY VALVES



For this page	Port size	Orifice (mm)	Kv (l/min)	MOPD (bar)	Fluid Temp (°C)
From	3/4"	20	140	5	-10
To	3"	75	1334	10	90

G	A		B		C	
	mm	inch	mm	inch	mm	inch
3/4"	100	3.93	107	4.21	65	2.56
1"	104	4.09	112.5	4.42	65	2.56

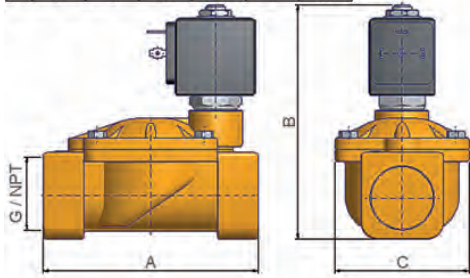

Drawing 057

G	A		B		C	
	mm	inch	mm	inch	mm	inch
1-1/4"	145	5.70	134	5.27	102	4.01
1-1/2"	145	5.70	134	5.27	102	4.01
2"	173	6.81	148	5.82	118	4.64

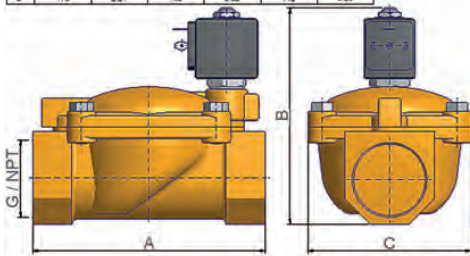

Drawing 058

G	A		B		C	
	mm	inch	mm	inch	mm	inch
2-1/2"	245	---	195	---	184	---
3"	250	---	195	---	184	---

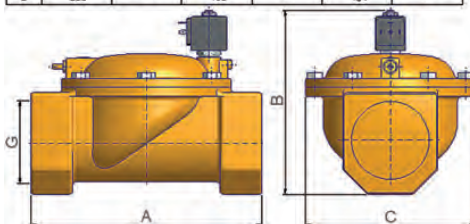

Drawing 059



## 2 WAY VALVES

# 2/2

## ANTI WATER HAMMER VALVES

### PILOT OPERATED

### BRASS

### PIPE MOUNTING

### NORMALLY CLOSED

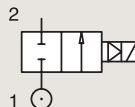

Port size	Orifice Ø	Flow factors			Operating Pressure Differential			Fluid Temp.		Seat Seal	Valve Ref.	Housing Ref.	Coil Ref.	Power		Coil Group	Dwg. No.
		Kv l/min	KV m <sup>3</sup> /h	Qn l/min	Min bar	AC bar	DC bar	Max °C	Max °C					AC W	DC W		
1/4"	12	32	1.92	2150	0.3	12	12	-10	100	FKM	321K4106	2995	481865	8	9	2.1/3.0	7094
	12	32	1.92	2150	0.3	12	12	-10	120	FKM	321K4106	4270	481000	8	8	2.1/3.0	7094
3/8"	12	45	2.7	3050	0.3	12	12	-10	100	FKM	321K4306	2995	481865	8	9	2.1/3.0	7094
	12	45	2.7	3050	0.3	12	12	-10	120	FKM	321K4306	4270	481000	8	8	2.1/3.0	7094
1/2"	12	50	3	3400	0.3	12	12	-10	100	FKM	321K4506	2995	481865	8	9	2.1/3.0	7094
	12	50	3	3400	0.3	12	12	-10	120	FKM	321K4506	4270	481000	8	8	2.1/3.0	7094
	12	50	3	3400	0.3	12	12	-10	100	FKM	321K4556 <sub>1</sub>	2995	481865	8	9	2.1/3.0	7094
	12	50	3	3400	0.3	12	12	-10	120	FKM	321K4556 <sub>1</sub>	4270	481000	8	8	2.1/3.0	7094
3/4"	18	100	6	9400	0.3	12	12	-10	100	FKM	321K4606	2995	481865	8	9	2.1/3.0	7099
	18	100	6	9400	0.3	12	12	-10	120	FKM	321K4606	4270	481000	8	8	2.1/3.0	7099
	18	100	6	9400	0.3	12	12	-10	100	FKM	321K4656 <sub>1</sub>	2995	481865	8	9	2.1/3.0	7099
	18	100	6	9400	0.3	12	12	-10	120	FKM	321K4656 <sub>1</sub>	4270	481000	8	8	2.1/3.0	7099
	20	135	8.1	9500	0.3	16	16	-10	100	NBR	E321G3610 <sub>2</sub>	2995	481865	8	9	2.0	3442
	20	135	8.1	9500	0.3	16	16	-10	100	NBR	E321G3610 <sub>2</sub>	4270	481000	8	8	2.0	3442

#### Notes:

1. With manual override

2. With manual override and 4 position selector for controlled closure rate - without manual override and without 4 position selector on request: use same reference removing suffix '10', e.g. E321G36



## 2 WAY VALVES



For this page	Port size	Orifice (mm)	Kv (l/min)	MOPD (bar)	Fluid Temp (°C)
From	1/4"	12	32	12	-10
To	3/4"	20	135	16	120

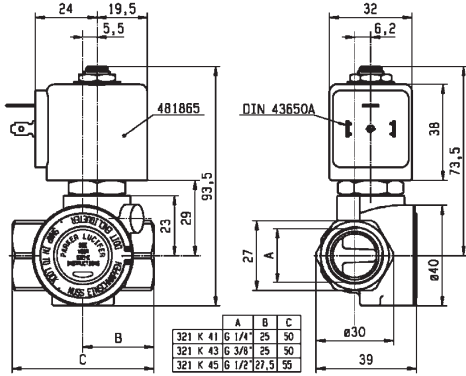

Drawing 7094

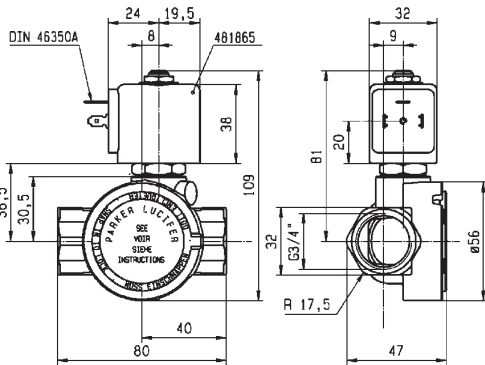

Drawing 7099

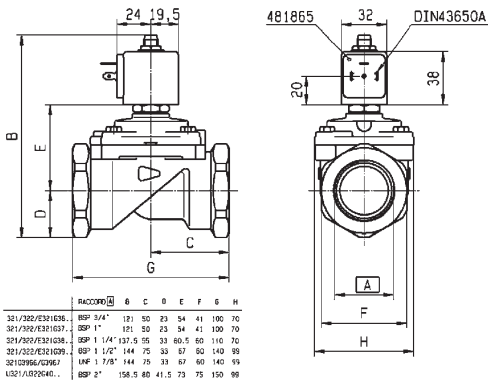

Drawing 3442



## 2 WAY VALVES

# 2/2

## ANTI WATER HAMMER VALVES

### PILOT OPERATED

### BRASS

### PIPE MOUNTING

### NORMALLY CLOSED

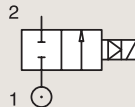

Port size	Orifice Ø	Flow factors			Operating Pressure Differential			Fluid Temp.		Seat Seal	Valve Ref.	Housing Ref.	Coil Ref.	Power		Coil Group	Dwg. No.
		Kv l/min	KV m <sup>2</sup> /h	Qn l/min	Min bar	AC bar	DC bar	Min °C	Max °C					AC W	DC W		
1"	18	110	6.6	10150	0.3	12	12	-10	100	FKM	321K4706	2995	481865	8	9	2.1/3.0	7100
	18	110	6.6	10150	0.3	12	12	-10	120	FKM	321K4706	4270	481000	8	8	2.1/3.0	7100
	18	110	6.6	10150	0.3	12	12	-10	100	FKM	321K4756 <sub>1</sub>	2995	481865	8	9	2.1/3.0	7100
	18	110	6.6	10150	0.3	12	12	-10	120	FKM	321K4756 <sub>1</sub>	4270	481000	8	8	2.1/3.0	7100
	25	180	10.8	14000	0.3	16	16	-10	100	NBR	E321G3710 <sub>2</sub>	2995	481865	8	9	2.0	3442
1 1/4"	28	280	16.8	18000	0.3	16	16	-10	100	NBR	E321G3810 <sub>2</sub>	2995	481865	8	9	2.0	3442
	28	280	16.8	18000	0.3	16	16	-10	100	NBR	E321G3810 <sub>2</sub>	4270	481000	8	8	2.0	3442
1 1/2"	40	420	25.2	31500	0.3	16	7	-10	100	FKM	E321G3910 <sub>2</sub>	2995	481865	8	9	2.0	3442
	40	420	25.2	31500	0.3	16	8.5	-10	100	FKM	E321G3910 <sub>2</sub>	4270	481000	8	8	2.0	3442
2"	40	540	32.4	40000	0.3	16	7	-10	100	FKM	E321G4010 <sub>2</sub>	2995	481865	8	9	2.0	3442
	40	540	32.4	40000	0.3	16	8.5	-10	100	FKM	E321G4010 <sub>2</sub>	4270	481000	8	8	2.0	3442

#### Notes:

1. With manual override

2. With manual override and 4 position selector for controlled closure rate - without manual override and without 4 position selector on request: use same reference removing suffix '10', e.g. E321G36

## 2 WAY VALVES



For this page	Port size	Orifice (mm)	Kv (l/min)	MOPD (bar)	Fluid Temp (°C)
From	1"	18	110	7	-10
To	2"	40	540	16	120

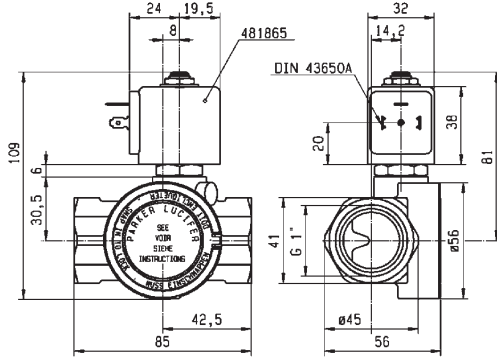

Drawing 7100

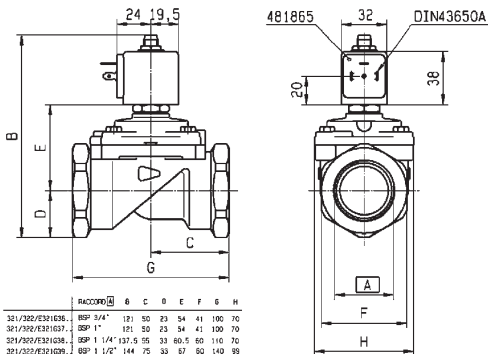

RACCORD	B	C	D	E	F	G	H
311/320/E311036..	BSP 3/4"	121	50	23	54	41	100 70
311/332/E321037..	BSP 1"	121	50	23	54	41	100 70
311/330/E311038..	BSP 1 1/4"	137.5	55	33	60.5	60	110 70
321/322/E31029..	BSP 1 1/2"	144	75	33	67	60	140 95
3210296/G296J	UNF 1 7/8"	144	75	33	67	60	140 95
U321/U320E40..	BSP 2"	158.5	80	41.5	73	75	150 99



Drawing 3442

## 2 WAY VALVES

# 2/2

## ANTI WATER HAMMER VALVES

### PILOT OPERATED

### BRASS

### PIPE MOUNTING

### NORMALLY OPEN

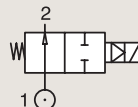

Port size	Orifice Ø	Flow factors			Operating Pressure Differential			Fluid Temp.		Seat Seal	Valve Ref.	Housing Ref.	Coil Ref.	Power		Coil Group	Dwg. No.
		Kv l/min	KV m <sup>2</sup> /h	Qn l/min	Min bar	Max(MOPD) AC bar	DC bar	Min °C	Max °C					AC W	DC W		
3/4"	20	135	8.1	9300	0.3	16	16	-10	100	NBR	322G3610	2995	481865	8	9	2.1	3442
	20	135	8.1	9300	0.3	16	16	-10	100	NBR	322G3610	4270	481000	8	8	2.1	3442
1"	25	180	10.8	14000	0.3	16	16	-10	100	NBR	322G3710	2995	481865	8	9	2.1	3442
	25	180	10.8	14000	0.3	16	16	-10	100	NBR	322G3710	4270	481000	8	8	2.1	3442
1 1/4"	28	270	16.2	18000	0.3	16	16	-10	100	NBR	322G3810	2995	481865	8	9	2.1	3442
	28	270	16.2	18000	0.3	16	16	-10	100	NBR	322G3810	4270	481000	8	8	2.1	3442
1 1/2"	40	425	25.5	31000	0.3	12	12	-10	100	NBR	322G3910	2995	481865	8	9	2.1	3442
	40	425	25.5	31000	0.3	12	12	-10	100	NBR	322G3910	4270	481000	8	8	2.1	3442
2"	40	540	32.4	40000	0.3	12	12	-10	100	NBR	322G4010	2995	481865	8	9	2.1	3442
	40	540	32.4	40000	0.3	12	12	-10	100	NBR	322G4010	4270	481000	8	8	2.1	3442

**Notes:**

1. With 4 position selector for controlled closure rate

## 2 WAY VALVES



For this page	Port size	Orifice (mm)	Kv (l/min)	MOPD (bar)	Fluid Temp (°C)
From	3/4"	20	135	12	-10
To	2"	40	540	16	100

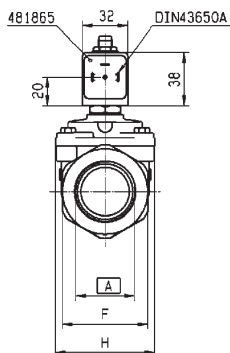
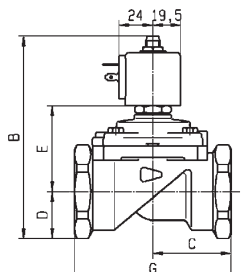

FACTOR	B	C	D	E	F	G	H
311/302/E311296	121	50	23	34	41	100	70
311/302/E311037	121	50	23	34	41	100	70
311/300/E311298	137.5	55	33	60.5	60	110	70
311/302/E311099	144	75	33	67	60	140	99
311/296/E2967	144	75	33	67	60	140	99
U321/A320640	158.5	80	41.5	73	75	150	99

Drawing 3442



## 2 WAY VALVES

### HOT WATER AND STEAM VALVES



# 2/2

Actuation	Body	Function	Port Size	Orifice (mm)	Flow Factor Kv(l/min)	MOPD (bar)	Max Fluid Temp. (°C)	Page Parker Valves
Direct Operated	Brass/Pipe Mounting	Normally Closed	1/4"	3 to 5	11	10	120	102
			3/8"	6	12	5	140	102
			1/2"	8.5 to 11	36	4	120	102
	303 Stainless St./Pipe Mounting	Normally Closed	1/4"	1.5 to 5	10	100	180	104
Magnalift	Brass/Pipe Mounting	Normally Closed	3/8"	15	65	10	140	106
			1/2"	15	65	10	140	106
			3/4"	15	80	10	140	106
			1"	15	80	10	140	106
Pilot Operated	Brass/Pipe Mounting	Normally Closed	1/2"	11 to 16	36	10	140	108

**2 WAY VALVES**

# 2/2

## HOT WATER AND STEAM VALVES

### DIRECT OPERATED

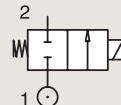
**BRASS**
**PIPE MOUNTING**
**NORMALLY CLOSED**

Port size	Orifice Ø	Flow factors			Operating Pressure Differential			Fluid Temp.		Seat Seal	Valve Ref.	Housing Ref.	Coil Ref.	Power		Coil Group	Dwg. No.
		Kv l/min	KV m³/h	Qn l/min	Min bar	Max(MOPD) AC bar	DC bar	Min °C	Max °C					AC W	DC W		
1/4"	3	4.5	0.27	-	0	10	7	0	100	EPDM	121K0323	2995	481865	8	9	2.0	3510
	3	4.5	0.27	-	0	10	8.5	0	120	EPDM	121K0323	4270	481000	8	8	2.0	3510
	3	4.5	0.27	-	0	10	10	0	120	EPDM	121K0323	4270	486265	14	14	2.0	3510
	3	4.5	0.27	-	0	10	10	0	120	EPDM	121K0323	2995	492425	14	14	2.0	3510
	5	11	0.66	750	0	7	2	0	100	EPDM	121K0103	2995	481865	8	9	2.0	3510
	5	11	0.66	750	0	7	2.8	0	120	EPDM	121K0103	4270	481000	8	8	2.0	3510
	5	11	0.66	750	0	7	5	0	120	EPDM	121K0103	4270	486265	14	14	2.0	3510
3/8"	5	11	0.66	750	0	4	3.5	0	120	EPDM	121K0103	2995	492425	14	14	2.0	3510
	6	12	0.72	1100	0	5	1.1	0	100	EPDM	121K3303	2995	481865	8	9	2.0	3551
	6	12	0.72	1100	0	5	1.5	0	120	EPDM	121K3303	4270	481000	8	8	2.0	3551
	6	12	0.72	1100	0	4	4	0	120	EPDM	121K3303	4270	486265	14	14	2.0	3551
1/2"	6	12	0.72	1100	0	4	4	0	140	EPDM	121K3303	2995	492425	14	14	2.0	3551
	8.5	25	1.5	-	0	2.2	0.5	0	120	EPDM	E121K4603	4270	481000	8	8	2.0	3427
	8.5	25	1.5	-	0	4	1.2	0	120	EPDM	E121K4603	4270	486265	14	14	2.0	3427
	8.5	25	1.5	-	0	4	1	0	120	EPDM	E121K4603	2995	492425	14	14	2.0	3427
	11	36	2.16	-	0	1.2	0.35	0	120	EPDM	E121K4503	4270	481000	8	8	2.0	3427
	11	36	2.16	-	0	2.5	0.7	0	120	EPDM	E121K4503	4270	486265	14	14	2.0	3427
	11	36	2.16	-	0	2.5	0.5	0	120	EPDM	E121K4503	2995	492425	14	14	2.0	3427



## 2 WAY VALVES



For this page	Port size	Orifice (mm)	Kv (l/min)	MOPD (bar)	Fluid Temp (°C)
From	1/4"	3	4.5	0.35	0
To	1/2"	11	36	10	140

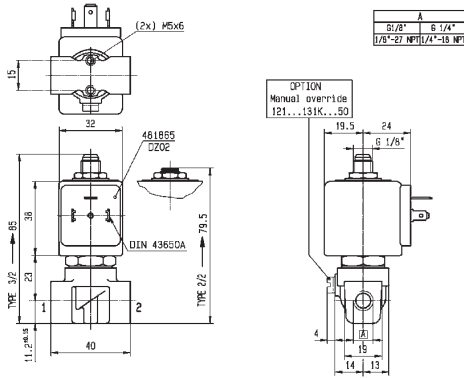

Drawing 3510

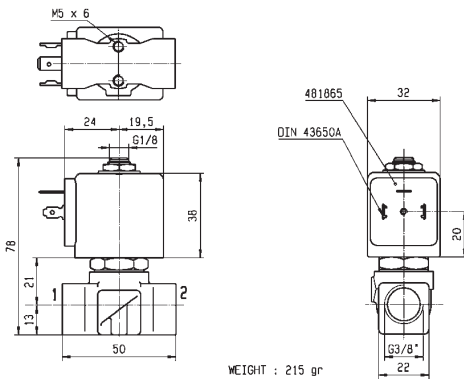

Drawing 3551

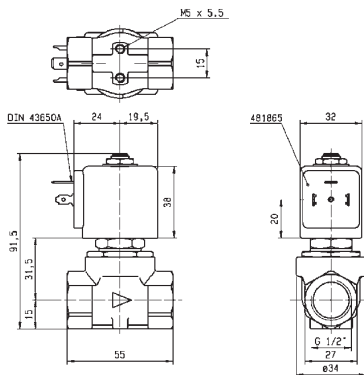

Drawing 3427

## 2 WAY VALVES

# 2/2

## HOT WATER AND STEAM VALVES

### DIRECT OPERATED

### 303 STAINLESS ST.

### PIPE MOUNTING

### NORMALLY CLOSED

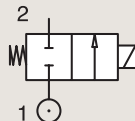

Port size (BSP)	Orifice Ø mm	Flow factors			Operating Pressure Differential Max(MOPD)			Fluid Temp.		Seat Seal	Valve Ref.	Housing Ref.	Coil Ref.	Power		Coil Group	Dwg. No.
		Kv l/min	KV m³/h	Qn m³/h	Min bar	AC bar	DC bar	Min °C	Max °C					AC W	DC W		
1/4"	1.5	1.5	0.09	80	0	60	25	0	100	Ruby	121V5463	2995	481865	8	9	2.0	8116
	1.5	1.5	0.09	80	0	75	30	0	130	Ruby	121V5463	4270	481000	8	8	2.0	8116
	1.5	1.5	0.09	80	0	100	55	0	140	Ruby	121V5463	4270	486265	14	14	2.0	8116
	2.5	3.5	0.21	220	0	28	10	0	100	Ruby	121V5763	2995	481865	8	9	2.0	8116
	2.5	3.5	0.21	220	0	34	12	0	130	Ruby	121V5763	4270	481000	8	8	2.0	8116
	2.5	3.5	0.21	220	0	50	22	0	140	Ruby	121V5763	4270	486265	14	14	2.0	8116
	3	4.5	0.27	315	0	20	7	0	100	Ruby	121V5363	2995	481865	8	9	2.0	8116
	3	4.5	0.27	315	0	25	8.5	0	130	Ruby	121V5363	4270	481000	8	8	2.0	8116
	3	4.5	0.27	315	0	36	15	0	140	Ruby	121V5363	4270	486265	14	14	2.0	8116
	4	7	0.42	450	0	12	4	0	100	Ruby	121V5263	2995	481865	8	9	2.0	8116
	4	7	0.42	450	0	15	5	0	130	Ruby	121V5263	4270	481000	8	8	2.0	8116
	4	7	0.42	450	0	22	10	0	180	Ruby	121V5263	4270	486265	14	14	2.0	8116
	5	10	0.6	750	0	8.5	2	0	100	Ruby	121V5163	2995	481865	8	9	2.0	8116
	5	10	0.6	750	0	10	3.5	0	130	Ruby	121V5163	4270	481000	8	8	2.0	8116
5	10	0.6	750	0	14	6.5	0	140	Ruby	121V5163	4270	486265	14	14	2.0	8116	
1/4" NPT	3	4.5	0.27	315	0	20	7	0	100	Ruby	U121V5363	2995	481865	8	8	2.0	8116

## 2 WAY VALVES

UK  
CA CE



For this page	Port size	Orifice (mm)	Kv (l/min)	MOPD (bar)	Fluid Temp (°C)
From	1/4"	1.5	1.5	2	0
To	1/4"	5	10	100	180

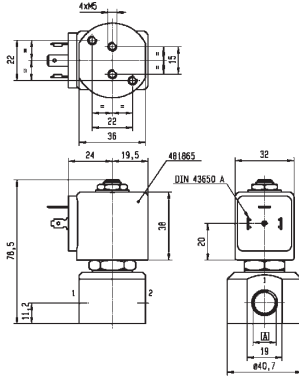

A G 1/8"  
G 1/4"



Drawing 8116

## 2 WAY VALVES

# 2/2

## HOT WATER AND STEAM VALVES

### MAGNALIFT

#### BRASS

#### PIPE MOUNTING

#### NORMALLY CLOSED

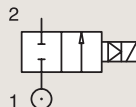

Port size	Orifice Ø	Flow factors			Operating Pressure Differential			Fluid Temp.		Seat Seal	Valve Ref.	Housing Ref.	Coil Ref.	Power		Coil Group	Dwg. No.
		Kv l/min	KV m³/h	Qn l/min	Min bar	Max(MOPD) DC bar	Min °C	Max °C	AC W					DC W			
3/8"	15	65	3.9	-	0	10	-	0	100	EPDM	221G1303	2995	481865	8	-	2.0	3732
	15	65	3.9	-	0	10	-	0	120	EPDM	221G1303	4270	481000	8	-	2.0	3732
	15	65	3.9	-	0	4	4	0	140	EPDM	221G1303	4270	486265	14	14	2.0	3732
	15	65	3.9	4500	0	10	10	-10	100	NBR	221G1330 <sub>1</sub>	2995	481865	8	9	2.1	3732
	15	65	3.9	4500	0	10	10	-10	65	NBR	221G1330 <sub>1</sub>	-	492070	9	8	2.1	3732
1/2"	15	65	3.9	-	0	10	-	0	100	EPDM	221G1503	2995	481865	8	-	2.0	3732
	15	65	3.9	-	0	10	-	0	120	EPDM	221G1503	4270	481000	8	-	2.0	3732
	15	65	3.9	-	0	10	7	0	140	EPDM	221G1503	4270	486265	14	14	2.0	3732
3/4"	15	80	4.8	-	0	10	-	0	100	EPDM	221G1603	2995	481865	8	-	2.0	3444
	15	80	4.8	-	0	10	-	0	120	EPDM	221G1603	4270	481000	8	-	2.0	3444
	15	80	4.8	-	0	4	4	0	140	EPDM	221G1603	4270	486265	14	14	2.0	3444
1"	15	80	4.8	6000	0	10	-	0	100	EPDM	221G1703	2995	481865	8	-	2.0	3445
	15	80	4.8	6000	0	10	-	0	120	EPDM	221G1703	2995	481000	8	-	2.0	3445
	15	80	4.8	6000	0	10	10	0	140	EPDM	221G1703	2995	486265	14	14	2.0	3445

#### Notes:

1. Valves with model number ending in 30 or 31 are mainly equipped with electrical parts for explosion proof applications or with standard DC coils.

## 2 WAY VALVES



For this page	Port size	Orifice (mm)	Kv (l/min)	MOPD (bar)	Fluid Temp (°C)
From	3/8"	15	65	4	-10
To	1"	15	80	10	140

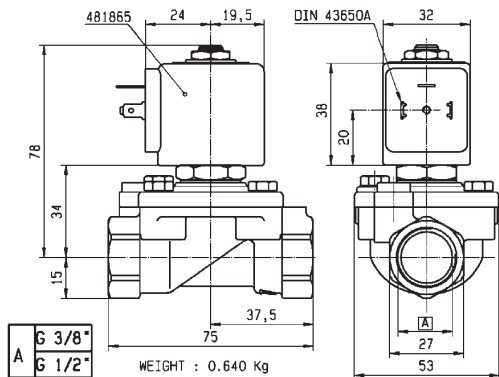

Drawing 3732

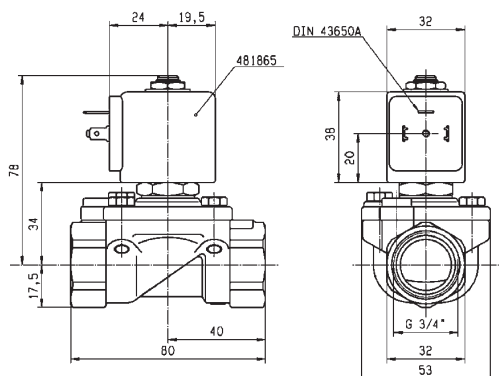

Drawing 3444

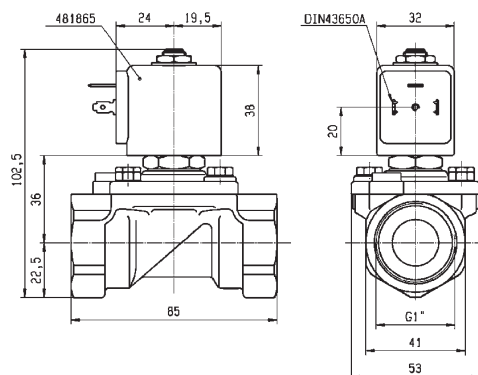

Drawing 3445



## 2 WAY VALVES

# 2/2

## HOT WATER AND STEAM VALVES

### PILOT OPERATED

BRASS

PIPE MOUNTING

**NORMALLY CLOSED**

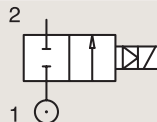

Port size (BSP)	Orifice Ø mm	Flow factors			Operating Pressure Differential			Fluid Temp.		Seat Seal	Valve Ref.	Housing Ref.	Coil Ref.	Power		Coil Group	Dwg. No.
		Kv l/min	KV m <sup>3</sup> /h	Qn m <sup>3</sup> /h	Min bar	Max(MOPD) AC bar	DC bar	Min °C	Max °C					AC W	DC W		
1/2"	11	36	2.16	2500	0.2	10	3	0	100	EPDM	E321K1503	2995	481865	8	9	2.0	3427
	11	36	2.16	2500	0.2	10	4	0	120	EPDM	E321K1503	4270	481000	8	8	2.0	3427
	11	36	2.16	2500	0.2	10	10	0	140	EPDM	E321K1503	4270	486265	14	14	2.0	3427

**Notes:**

1. Maximum pressure for steam: 4Bar (140°C)

## 2 WAY VALVES



For this page	Port size	Orifice (mm)	Kv (l/min)	MOPD (bar)	Fluid Temp (°C)
From	1/2"	11	36	3	0
To	1/2"	11	36	10	140

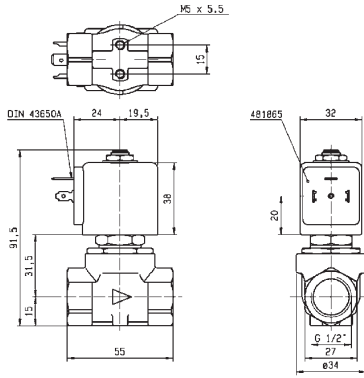

Drawing 3427



## 2 WAY VALVES



### VALVES FOR HYDRAULIC OIL AND NEUTRAL LIQUIDS (UP TO 100 BAR)



# 2/2

Actuation	Body	Function	Port Size	Orifice (mm)	Flow Factor Kv(l/min)	MOPD (bar)	Max Fluid Temp. (°C)	Page Parker Valves	
Direct Operated	Brass/Pipe Mounting	Normally Closed	1/8"	1.5 to 2.5	3.5	70	130	112	
			1/4"	1.2 to 3	4.5	100	130	112	
			3/8"	4 to 6	12	10	120	114	
		Normally Open	1/8"	2.5	3.5	30	140	114	
			1/4"	1.5 to 2.5	3.5	40	140	114	
			5 mm	1.5 to 3	4.5	100	130	116	
Pilot Operated	Brass/Pipe Mounting	Normally Closed	1/4"	8	36	40	140	118	
			3/8"	11	50	40	140	118	
			1/2"	15	60	40	140	120	
		Normally Open	1/4"	8	36	40	140	122	
			3/8"	11	50	40	140	122	
			1/2"	15	60	40	140	122	
		Brass/Sub-base Mounting	Normally Closed	14 mm	14	45	40	140	124
			Normally Open	14 mm	14	45	40	120	124

## 2 WAY VALVES

# 2/2

### VALVES FOR HYDRAULIC OIL AND NEUTRAL LIQUIDS (UP TO 100 BAR) DIRECT OPERATED

#### BRASS

#### PIPE MOUNTING

#### NORMALLY CLOSED

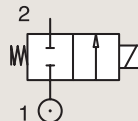

Port size (BSP)	Orifice Ø mm	Flow factors			Operating Pressure Differential			Fluid Temp.		Seat Seal	Valve Ref.	Housing Ref.	Coil Ref.	Power		Coil Group	Dwg. No.
		Kv l/min	KV m³/h	Qn m³/h	Min bar	AC bar	DC bar	Min °C	Max °C					AC W	DC W		
1/8"	1.5	1.5	0.09	80	0	60	25	-30	75	PCTFE	E121K14	2995	481865	8	9	2.0	3510
	1.5	1.5	0.09	80	0	70	30	-30	75	PCTFE	E121K14	4270	481000	8	8	2.0	3510
	1.5	1.5	0.09	80	0	70	55	-30	75	PCTFE	E121K14	4270	486265	14	14	2.0	3510
	2.5	3.5	0.21	220	0	28	10	-30	100	Ruby	E121K23	2995	481865	8	9	2.0	3510
	2.5	3.5	0.21	220	0	34	12	-30	130	Ruby	E121K23	4270	481000	8	8	2.0	3510
	2.5	3.5	0.21	220	0	50	22	-30	120	Ruby	E121K23	4270	486265	14	14	2.0	3510
1/4"	1.2	0.85	0.05	50	0	80	36	-30	100	Ruby	E121K65	2995	481865	8	9	2.0	3510
	1.2	0.85	0.05	50	0	100	43	-30	130	Ruby	E121K65	4270	481000	8	8	2.0	3510
	1.2	0.85	0.05	50	0	100	75	-30	120	Ruby	E121K65	4270	486265	14	14	2.0	3510
	1.5	1.5	0.09	80	0	60	25	-30	75	PCTFE	E121K04	2995	481865	8	9	2.0	3510
	1.5	1.5	0.09	80	0	70	30	-30	75	PCTFE	E121K04	4270	481000	8	8	2.0	3510
	1.5	1.5	0.09	80	0	70	55	-30	75	PCTFE	E121K04	4270	486265	14	14	2.0	3510
	1.5	1.5	0.09	80	0	60	25	-30	100	Ruby	E121K67	2995	481865	8	9	2.0	3510
	1.5	1.5	0.09	80	0	75	30	-30	130	Ruby	E121K67	4270	481000	8	8	2.0	3510
	1.5	1.5	0.09	80	0	100	55	-30	120	Ruby	E121K67	4270	486265	14	14	2.0	3510
	2.5	3.5	0.21	220	0	28	10	-30	100	Ruby	E121K63	2995	481865	8	9	2.0	3510
	2.5	3.5	0.21	220	0	34	12	-30	130	Ruby	E121K63	4270	481000	8	8	2.0	3510
	2.5	3.5	0.21	220	0	50	22	-30	120	Ruby	E121K63	4270	486265	14	14	2.0	3510
	3	4.5	0.27	320	0	20	7	-30	75	PCTFE	E121K03	2995	481865	8	9	2.0/3.0	3510
	3	4.5	0.27	320	0	25	8.5	-30	75	PCTFE	E121K03	4270	481000	8	8	2.0/3.0	3510
	3	4.5	0.27	320	0	36	15	-30	75	PCTFE	E121K03	4270	486265	14	14	2.0/3.0	3510
	3	4.5	0.27	320	0	20	7	-30	100	Ruby	E121K64	2995	481865	8	9	2.0	3510
	3	4.5	0.27	320	0	25	8.5	-30	130	Ruby	E121K64	4270	481000	8	8	2.0	3510
	3	4.5	0.27	320	0	36	15	-30	120	Ruby	E121K64	4270	486265	14	14	2.0	3510

## 2 WAY VALVES



For this page	Port size	Orifice (mm)	Kv (l/min)	MOPD (bar)	Fluid Temp (°C)
From	1/8"	1.2	0.85	7	-30
To	1/4"	3	4.5	100	130

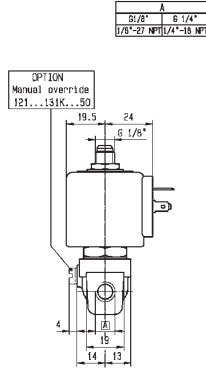
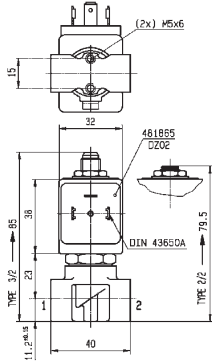

Drawing 3510

## 2 WAY VALVES

# 2/2

### VALVES FOR HYDRAULIC OIL AND NEUTRAL LIQUIDS (UP TO 100 BAR) DIRECT OPERATED

#### BRASS

#### PIPE MOUNTING

#### NORMALLY CLOSED

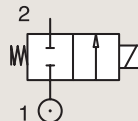

Port size (BSP)	Orifice Ø mm	Flow factors			Operating Pressure Differential			Fluid Temp. °C		Seat Seal	Valve Ref.	Housing Ref.	Coil Ref.	Power		Coil Group	Dwg. No.
		Kv l/min	KV m³/h	Qn m³/h	Min bar	Max(MOPD) AC bar	DC bar	Min °C	Max °C					AC W	DC W		
3/8"	4	7.5	0.45	480	0	10	4	-10	100	FKM	121K3206	2995	481865	8	9	2.0	3551
	4	7.5	0.45	480	0	10	5	-10	120	FKM	121K3206	4270	481000	8	8	2.0	3551
	4	7.5	0.45	480	0	10	10	-10	120	FKM	121K3206	4270	486265	14	14	2.0	3551
	5	11	0.66	750	0	7	2	-10	100	FKM	121K3106	2995	481865	8	9	2.0	3551
	5	11	0.66	750	0	7	2.8	-10	120	FKM	121K3106	4270	481000	8	8	2.0	3551
	5	11	0.66	750	0	7	5	-10	120	FKM	121K3106	4270	486265	14	14	2.0	3551
	6	12	0.72	1100	0	5	1.1	-10	100	FKM	121K3306	2995	481865	8	9	2.0/14.2	3551
	6	12	0.72	1100	0	5	1.5	-10	120	FKM	121K3306	4270	481000	8	8	2.0/14.2	3551
6	12	0.72	1100	0	5	3	-10	120	FKM	121K3306	4270	486265	14	14	2.0/14.2	3551	

#### BRASS

#### PIPE MOUNTING

#### NORMALLY OPEN

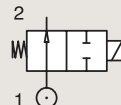

Port size (BSP)	Orifice Ø mm	Flow factors			Operating Pressure Differential			Fluid Temp. °C		Seat Seal	Valve Ref.	Housing Ref.	Coil Ref.	Power		Coil Group	Dwg. No.
		Kv l/min	KV m³/h	Qn l/min	Min bar	Max(MOPD) AC bar	DC bar	Min °C	Max °C					AC W	DC W		
1/8"	2.5	3.5	0.21	-	0	30	-	-30	140	Ruby	122K9363	4270	481044	14	-	2.2	3510
	2.5	3.5	0.21	-	0	30	30	-30	140	Ruby	122K9363	4270	486265	14	14	2.2	3510
1/4"	1.5	1.5	0.09	80	0	30	30	-10	100	PCTFE	122K84	2995	481865	8	9	2.0	3510
	1.5	1.5	0.09	80	0	30	30	-10	100	PCTFE	122K84	4270	481000	8	8	2.0	3510
	1.5	1.5	0.09	80	0	30	30	-10	120	PCTFE	122K84	4270	486265	14	14	2.0	3510
	1.5	1.5	0.09	80	0	40	40	-30	100	Ruby	122K8408	2995	481865	8	9	2.0	3510
	1.5	1.5	0.09	80	0	40	40	-30	130	Ruby	122K8408	4270	481000	8	8	2.0	3510
	1.5	1.5	0.09	80	0	40	40	-30	130	Ruby	122K8408	4270	486265	14	14	2.0	3510
	2.5	3.5	0.21	-	0	30	-	-30	140	Ruby	122K8363	4270	481044	14	-	2.2	3510
	2.5	3.5	0.21	-	0	30	30	-30	140	Ruby	122K8363	4270	486265	14	14	2.2	3510



## 2 WAY VALVES



For this page	Port size	Orifice (mm)	Kv (l/min)	MOPD (bar)	Fluid Temp (°C)
From	1/8"	1.5	1.5	1.1	-30
To	3/8"	6	12	40	140

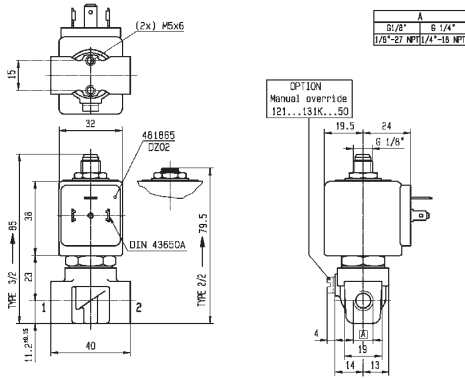

Drawing 3510

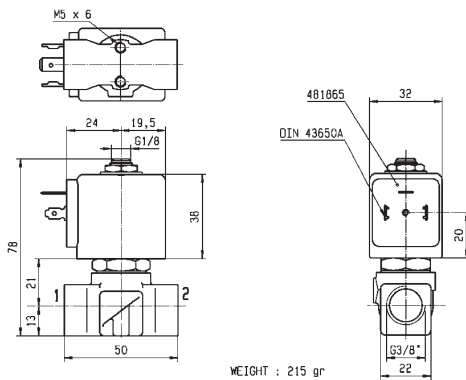

Drawing 3551

## 2 WAY VALVES

# 2/2

### VALVES FOR HYDRAULIC OIL AND NEUTRAL LIQUIDS (UP TO 100 BAR) DIRECT OPERATED

#### BRASS

#### SUB-BASE MOUNTING

#### NORMALLY CLOSED

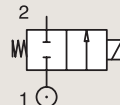

Port size	Orifice Ø mm	Flow factors			Operating Pressure Differential			Fluid Temp.		Seat Seal	Valve Ref.	Housing Ref.	Coil Ref.	Power		Coil Group	Dwg. No.
		Kv l/min	KV m³/h	Qn l/min	Min bar	Max(MOPD) DC bar	Min °C	Max °C	AC W					DC W			
SB	1.5	1.5	0.09	80	0	60	25	-30	100	Ruby	121F67	2995	481865	8	9	2.0	3509
	1.5	1.5	0.09	80	0	75	30	-30	130	Ruby	121F67	4270	481000	8	8	2.0	3509
	1.5	1.5	0.09	80	0	100	55	-30	120	Ruby	121F67	4270	486265	14	14	2.0	3509
	1.5	1.5	0.09	80	0	60	25	-30	75	PCTFE	E121F44	2995	481865	8	9	2.0	3509
	1.5	1.5	0.09	80	0	70	30	-30	75	PCTFE	E121F44	4270	481000	8	8	2.0	3509
	1.5	1.5	0.09	80	0	70	55	-30	75	PCTFE	E121F44	4270	486265	14	14	2.0	3509
	2.5	3.5	0.21	220	0	14	7	-10	100	FKM	121F4706	2995	481865	8	9	2.0	3509
	2.5	3.5	0.21	220	0	14	9	-10	120	FKM	121F4706	4270	481000	8	8	2.0	3509
	2.5	3.5	0.21	220	0	14	14	-10	120	FKM	121F4706	4270	486265	14	14	2.0	3509
	2.5	3.5	0.21	220	0	28	10	-30	100	Ruby	121F63	2995	481865	8	9	2.0	3509
	2.5	3.5	0.21	220	0	34	12	-30	130	Ruby	121F63	4270	481000	8	8	2.0	3509
	2.5	3.5	0.21	220	0	50	22	-30	120	Ruby	121F63	4270	486265	14	14	2.0	3509
	3	4.5	0.27	320	0	20	7	-30	100	Ruby	121F64	2995	481865	8	9	2.0	3509
	3	4.5	0.27	320	0	25	8.5	-30	130	Ruby	121F64	4270	481000	8	8	2.0	3509
	3	4.5	0.27	320	0	36	15	-30	120	Ruby	121F64	4270	486265	14	14	2.0	3509
	3	4.5	0.27	320	0	20	7	-30	75	PCTFE	E121F43	2995	481865	8	9	2.0	3509
	3	4.5	0.27	320	0	25	8.5	-30	75	PCTFE	E121F43	4270	481000	8	8	2.0	3509
	3	4.5	0.27	320	0	36	15	-30	75	PCTFE	E121F43	4270	486265	14	14	2.0	3509

## 2 WAY VALVES



For this page	Port size	Orifice (mm)	Kv (l/min)	MOPD (bar)	Fluid Temp (°C)
From	5 mm	1.5	1.5	7	-30
To	5 mm	3	4.5	100	130

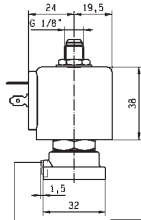
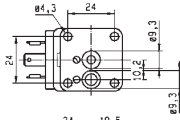

OPTION  
Manual override  
121...131F...50

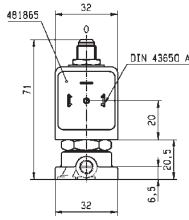

Drawing 3509

## 2 WAY VALVES

# 2/2

## VALVES FOR HYDRAULIC OIL AND NEUTRAL LIQUIDS (UP TO 100 BAR) PILOT OPERATED

### BRASS

### PIPE MOUNTING

### NORMALLY CLOSED

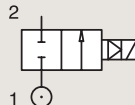

Port size	Orifice Ø	Flow factors			Operating Pressure Differential			Fluid Temp.		Seat Seal	Valve Ref.	Housing Ref.	Coil Ref.	Power		Coil Group	Dwg. No.
		Kv l/min	KV m <sup>3</sup> /h	Qn l/min	Min bar	Max(MOPD) AC bar	DC bar	Min °C	Max °C					AC W	DC W		
1/4"	8	36	2.16	1600	0.3	40	25	-10	100	NBR	E321H11 <sub>12</sub>	2995	481865	8	9	2.0	3523
	8	36	2.16	1600	0.3	40	30	-10	100	NBR	E321H11 <sub>12</sub>	4270	481000	8	8	2.0	3523
	8	36	2.16	1600	0.3	40	40	-10	100	NBR	E321H11 <sub>12</sub>	4270	486265	14	14	2.0	3523
	8	36	2.16	-	0.3	40	25	-10	100	FKM	E321H21 <sub>12</sub>	2995	481865	8	9	2.0	3523
	8	36	2.16	-	0.3	40	30	-10	120	FKM	E321H21 <sub>12</sub>	4270	481000	8	8	2.0	3523
	8	36	2.16	-	0.3	40	40	-10	140	FKM	E321H21 <sub>12</sub>	4270	486265	14	14	2.0	3523
3/8"	11	50	3	2800	0.3	40	25	-10	100	NBR	E321H13 <sub>12</sub>	2995	481865	8	9	2.0	3521
	11	50	3	2800	0.3	40	30	-10	100	NBR	E321H13 <sub>12</sub>	4270	481000	8	8	2.0	3521
	11	50	3	2800	0.3	40	40	-10	100	NBR	E321H13 <sub>12</sub>	4270	486265	14	14	2.0	3521
	11	50	3	-	0.3	40	25	-10	100	FKM	E321H23 <sub>12</sub>	2995	481865	8	9	2.0	3521
	11	50	3	-	0.3	40	30	-10	120	FKM	E321H23 <sub>12</sub>	4270	481000	8	8	2.0	3521
	11	50	3	-	0.3	40	40	-10	140	FKM	E321H23 <sub>12</sub>	4270	486265	14	14	2.0	3521
	11	36	2.16	-	0.2	20	3	-10	100	Ruby	E321K63	2995	483510	9	-	2.0	3429
	11	36	2.16	-	0.2	30	4	-10	140	Ruby	E321K63	4270	488553	9	-	2.0	3429
	11	36	2.16	-	0.2	4	4	-10	75	Ruby	E321K63	-	492190	11	9	2.0	3429

#### Notes:

1. Minimum pressure differential = 0.3 bar for opening and 0 bar for closing
2. Pilot seat disc in synthetic Ruby

## 2 WAY VALVES



For this page	Port size	Orifice (mm)	Kv (l/min)	MOPD (bar)	Fluid Temp (°C)
From	1/4"	8	36	3	-10
To	3/8"	11	50	40	140

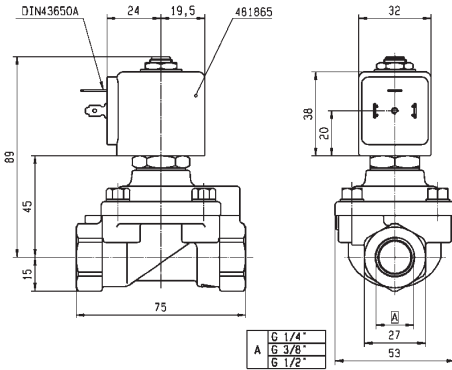

Drawing 3523

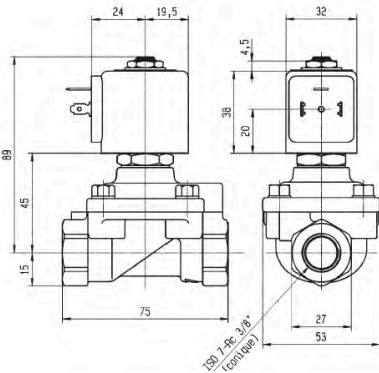

Drawing 3521

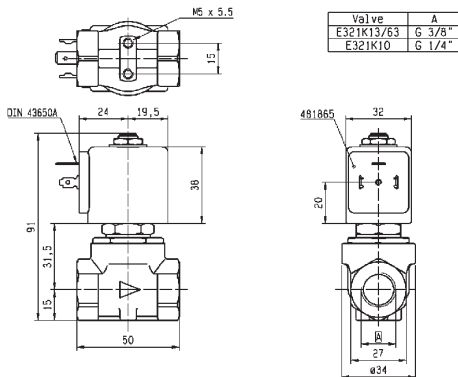

Drawing 3429

## 2 WAY VALVES

# 2/2

## VALVES FOR HYDRAULIC OIL AND NEUTRAL LIQUIDS (UP TO 100 BAR) PILOT OPERATED

### BRASS

### PIPE MOUNTING

### NORMALLY CLOSED

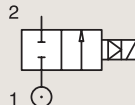

Port size	Orifice Ø	Flow factors			Operating Pressure Differential			Fluid Temp.		Seat Seal	Valve Ref.	Housing Ref.	Coil Ref.	Power		Coil Group	Dwg. No.
		Kv l/min	KV m³/h	Qn l/min	Min bar	AC bar	DC bar	Min °C	Max °C					AC W	DC W		
1/2"	15	60	3.6	3150	0.3	40	25	-10	100	NBR	E321H15 <sub>12</sub>	2995	481865	8	9	2.0	3522
	15	60	3.6	3150	0.3	40	30	-10	100	NBR	E321H15 <sub>12</sub>	4270	481000	8	8	2.0	3522
	15	60	3.6	3150	0.3	40	40	-10	100	NBR	E321H15 <sub>12</sub>	4270	486265	14	14	2.0	3522
	15	60	3.6	-	0.3	40	25	-10	100	FKM	E321H25 <sub>12</sub>	2995	481865	8	9	2.0/14.2	3522
	15	60	3.6	-	0.3	40	30	-10	65	FKM	E321H25 <sub>12</sub>	-	483371	8	8	2.0/14.2	3522
	15	60	3.6	-	0.3	40	40	-10	140	FKM	E321H25 <sub>12</sub>	4270	486265	14	14	2.0/14.2	3522

#### Notes:

1. Minimum pressure differential = 0.3 bar for opening and 0 bar for closing
2. Pilot seat disc in synthetic Ruby

## 2 WAY VALVES



For this page	Port size	Orifice (mm)	Kv (l/min)	MOPD (bar)	Fluid Temp (°C)
From	1/2"	15	60	25	-10
To	1/2"	15	60	40	140

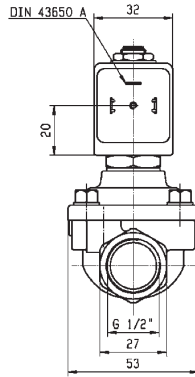
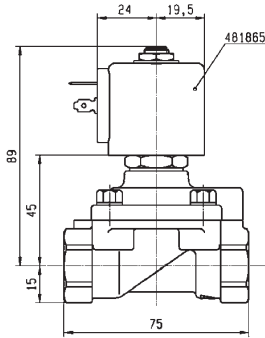

Drawing 3522

## 2 WAY VALVES

# 2/2

## VALVES FOR HYDRAULIC OIL AND NEUTRAL LIQUIDS (UP TO 100 BAR) PILOT OPERATED

### BRASS

### PIPE MOUNTING

### NORMALLY OPEN

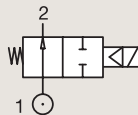

Port size	Orifice Ø	Flow factors			Operating Pressure Differential			Fluid Temp.		Seat Seal	Valve Ref.	Housing Ref.	Coil Ref.	Power		Coil Group	Dwg. No.
		Kv l/min	KV m <sup>3</sup> /h	Qn l/min	Min bar	AC bar	DC bar	Min °C	Max °C					AC W	DC W		
1/4"	8	36	2.16	1600	0.3	40	40	-10	100	FKM	322H7106 <sub>12</sub>	2995	481865	8	9	2.0/14.1	3523
	8	36	2.16	1600	0.3	40	40	-10	120	FKM	322H7106 <sub>12</sub>	4270	481000	8	8	2.0/14.1	3523
	8	36	2.16	1600	0.3	40	40	-10	140	FKM	322H7106 <sub>12</sub>	4270	486265	14	14	2.0/14.1	3523
3/8"	11	50	3	3240	0.3	40	40	-10	75	NBR	322H73 <sub>12</sub>	2995	481865	8	9	2.0	3523
	11	50	3	3240	0.3	40	40	-10	75	NBR	322H73 <sub>12</sub>	4270	481000	8	8	2.0	3523
	11	50	3	3240	0.3	40	40	-10	75	NBR	322H73 <sub>12</sub>	4270	486265	14	14	2.0	3523
	11	50	3	3240	0.3	40	40	-10	100	FKM	322H7306 <sub>12</sub>	2995	481865	8	9	2.0/14.1	3523
	11	50	3	3240	0.3	40	40	-10	100	FKM	322H7306 <sub>12</sub>	4270	481000	8	8	2.0/14.1	3523
	11	50	3	3240	0.3	40	40	-10	140	FKM	322H7306 <sub>12</sub>	4270	486265	14	14	2.0/14.1	3523
1/2"	15	60	3.6	3890	0.3	20	20	-10	100	FKM	322G7506 <sub>1</sub>	2995	481865	8	9	2.0	3522
	15	60	3.6	3890	0.3	20	20	-10	100	FKM	322G7506 <sub>1</sub>	4270	481000	8	8	2.0	3522
	15	60	3.6	3890	0.3	20	20	-10	100	FKM	322G7506 <sub>1</sub>	4270	486265	14	14	2.0	3522
	15	60	3.6	3890	0.3	40	40	-10	100	NBR	322H75 <sub>12</sub>	2995	481865	8	9	2.0	3522
	15	60	3.6	3890	0.3	40	40	-10	100	NBR	322H75 <sub>12</sub>	4270	481000	8	8	2.0	3522
	15	60	3.6	3890	0.3	40	40	-10	100	NBR	322H75 <sub>12</sub>	4270	486265	14	14	2.0	3522
	15	60	3.6	3890	0.3	40	40	-10	100	FKM	322H7506 <sub>12</sub>	2995	481865	8	9	2.0/14.1	3522
	15	60	3.6	3890	0.3	40	40	-10	120	FKM	322H7506 <sub>12</sub>	4270	481000	8	8	2.0/14.1	3522
	15	60	3.6	3890	0.3	40	40	-10	140	FKM	322H7506 <sub>12</sub>	4270	486265	14	14	2.0/14.1	3522

#### Notes:

1. Minimum pressure differential = 0.3 bar for opening and 0 bar for closing
2. Pilot seat disc in synthetic Ruby

## 2 WAY VALVES



For this page	Port size	Orifice (mm)	Kv (l/min)	MOPD (bar)	Fluid Temp (°C)
From	1/4"	8	36	20	-10
To	1/2"	15	60	40	140

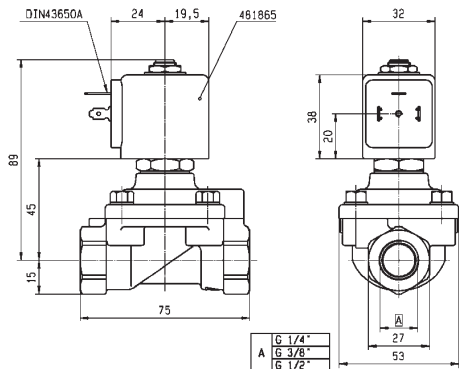

Drawing 3523

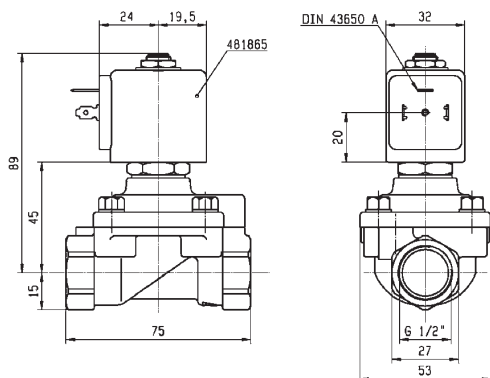

Drawing 3522



## 2 WAY VALVES

# 2/2

### VALVES FOR HYDRAULIC OIL AND NEUTRAL LIQUIDS (UP TO 100 BAR) PILOT OPERATED

#### BRASS

#### SUB-BASE MOUNTING

#### NORMALLY CLOSED

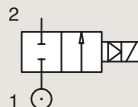

Port size	Orifice Ø	Flow factors			Operating Pressure Differential			Fluid Temp.		Seat Seal	Valve Ref.	Housing Ref.	Coil Ref.	Power		Coil Group	Dwg. No.
		Kv l/min	KV m³/h	Qn l/min	Min bar	Max(MOPD) AC bar	DC bar	Min °C	Max °C					AC W	DC W		
BSP	14	45	2.7	-	0.3	40	25	-10	100	FKM	E321F3202 <sub>12</sub>	2995	481865	8	9	2.0	3520
SB	14	45	2.7	-	0.3	40	30	-10	120	FKM	E321F3202 <sub>12</sub>	4270	481000	8	8	2.0	3520
	14	45	2.7	-	0.3	40	40	-10	140	FKM	E321F3202 <sub>12</sub>	4270	486265	14	14	2.0	3520

#### Notes:

1. Minimum pressure differential = 0.3 bar for opening and 0 bar for closing
2. Pilot seat disc in synthetic Ruby

#### BRASS

#### SUB-BASE MOUNTING

#### NORMALLY OPEN

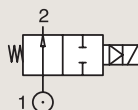

Port size	Orifice Ø	Flow factors			Operating Pressure Differential			Fluid Temp.		Seat Seal	Valve Ref.	Housing Ref.	Coil Ref.	Power		Coil Group	Dwg. No.
		Kv l/min	KV m³/h	Qn l/min	Min bar	Max(MOPD) AC bar	DC bar	Min °C	Max °C					AC W	DC W		
BSP	14	45	2.7	-	0.3	40	40	0	100	FKM	322F7206 <sub>12</sub>	2995	481865	8	9	2.1/14.1	3520
SB	14	45	2.7	-	0.3	40	40	0	120	FKM	322F7206 <sub>12</sub>	4270	481000	8	8	2.1/14.1	3520

#### Notes:

1. Minimum pressure differential = 0.3 bar for opening and 0 bar for closing
2. Pilot seat disc in synthetic Ruby

## 2 WAY VALVES

UK  
CA CE



For this page	Port size	Orifice (mm)	Kv (l/min)	MOPD (bar)	Fluid Temp (°C)
From	14 mm	14	45	25	-10
To	14 mm	14	45	40	140

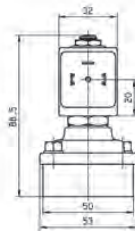
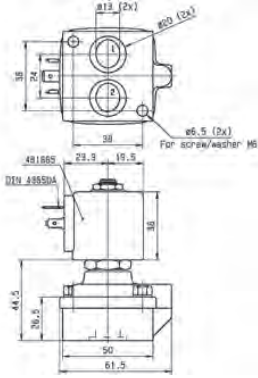

Drawing 3520



## 2 WAY VALVES



### HIGH CORROSION RESISTANT VALVES (303 STAINLESS ST.) STEEL



# 2/2

Actuation	Body	Function	Port Size	Orifice (mm)	Flow Factor Kv(l/min)	MOPD (bar)	Max Fluid Temp. (°C)	Page Parker Valves
Direct Operated	303 Stainless St./Pipe Mounting	Normally Closed	1/4"	1.5 to 5	10	100	180	128 and 130
		Normally Open	1/4"	2.5	3	12	120	132

## 2 WAY VALVES

# 2/2

## HIGH CORROSION RESISTANT VALVES (303 STAINLESS ST.) DIRECT OPERATED



Process

### 303 STAINLESS ST. PIPE MOUNTING

#### NORMALLY CLOSED

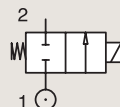

Port size	Orifice Ø	Flow factors			Operating Pressure Differential			Fluid Temp.		Seat Seal	Valve Ref.	Housing Ref.	Coil Ref.	IS	Power		Coil Group	Dwg. No.
		Kv	KV	Qn	Min	Max(MOPD)	DC	Min	Max						AC	DC		
BSP	mm	l/min	m <sup>3</sup> /h	m <sup>3</sup> /h	bar	AC bar	DC bar	°C	°C					W	W			
1/4"	1.5	1.5	0.09	80	0	20	20	-10	100	FKM	121V5406	2995	481865	8	9	2.0	8116	
	1.5	1.5	0.09	80	0	20	20	-10	120	FKM	121V5406	4270	481000	8	8	2.0	8116	
	1.5	1.5	0.09	80	0	60	25	0	100	Ruby	121V5463 <sub>1</sub>	2995	481865	8	9	2.0	8116	
	1.5	1.5	0.09	80	0	75	30	0	130	Ruby	121V5463 <sub>1</sub>	4270	481000	8	8	2.0	8116	
	1.5	1.5	0.09	80	0	100	55	0	140	Ruby	121V5463 <sub>1</sub>	4270	486265	14	14	2.0	8116	
	1.5	1.5	0.09	80	0	-	8	-20	75	PUR	121V5497 <sub>2</sub>	2995	482740	-	1.6	6.0/8.0	8116	
	1.5	1.5	0.09	80	0	10	10	-20	75	PUR	121V5497 <sub>2</sub>	-	495900	2.5	2	6.0/8.0	8024	
	1.5	1.5	0.09	80	0	-	10	-20	75	PUR	121V5497 <sub>2</sub>	-	495910	*	-	0.3-1.2	6.0/8.0	8024
	1.5	1.5	0.09	80	0	-	8	-20	65	PUR	121V5497 <sub>2</sub>	2995	496125	-	1.6	6.0/8.0	8116	
	2.5	3.5	0.21	220	0	14	7	-10	100	FKM	121V5706	2995	481865	8	9	2.0	8116	
	2.5	3.5	0.21	220	0	14	9	-10	120	FKM	121V5706	4270	481000	8	8	2.0	8116	
	2.5	3.5	0.21	220	0	14	14	-10	120	FKM	121V5706	4270	486265	14	14	2.0	8116	
	2.5	3.5	0.21	220	0	28	10	0	100	Ruby	121V5763 <sub>1</sub>	2995	481865	8	9	2.0	8116	
	2.5	3.5	0.21	220	0	34	12	0	130	Ruby	121V5763 <sub>1</sub>	4270	481000	8	8	2.0	8116	
	2.5	3.5	0.21	220	0	50	22	0	140	Ruby	121V5763 <sub>1</sub>	4270	486265	14	14	2.0	8116	
	3	4.5	0.27	315	0	10	7	-10	100	FKM	121V5306	2995	481865	8	9	2.0	8116	
	3	4.5	0.27	315	0	10	8.5	-10	120	FKM	121V5306	4270	481000	8	8	2.0	8116	
	3	4.5	0.27	315	0	10	10	-10	120	FKM	121V5306	4270	486265	14	14	2.0	8116	
	3	4.5	0.27	315	0	20	7	0	100	Ruby	121V5363 <sub>1</sub>	2995	481865	8	9	2.0	8116	
	3	4.5	0.27	315	0	25	8.5	0	130	Ruby	121V5363 <sub>1</sub>	4270	481000	8	8	2.0	8116	
3	4.5	0.27	315	0	36	15	0	140	Ruby	121V5363 <sub>1</sub>	4270	486265	14	14	2.0	8116		

**Notes:**

1. Valve only compatible with hydraulic oil and neutral liquids
2. If media is water, the fluid temperature shall not exceed 40°C.



## 2 WAY VALVES



For this page	Port size	Orifice (mm)	Kv (l/min)	MOPD (bar)	Fluid Temp (°C)
From	1/4"	1.5	1.5	7	-20
To	1/4"	3	4.5	100	140

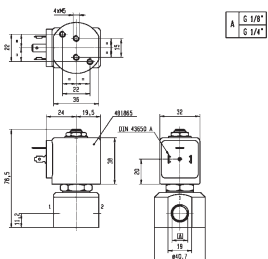

Drawing 8116

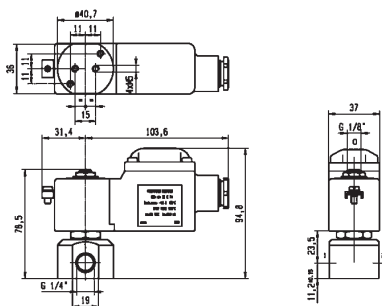

Drawing 8024

## 2 WAY VALVES

# 2/2

## HIGH CORROSION RESISTANT VALVES (303 STAINLESS ST.) DIRECT OPERATED

### 303 STAINLESS ST.

### PIPE MOUNTING

### NORMALLY CLOSED

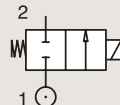

Port size	Orifice Ø	Flow factors			Operating Pressure Differential			Fluid Temp.		Seat Seal	Valve Ref.	Housing Ref.	Coil Ref.	IS		Power	Coil Group	Dwg. No.
		Kv l/min	KV m³/h	Qn m³/h	Min bar	Max(MOPD) AC bar	DC bar	Min °C	Max °C					AC W	DC W			
1/4"	3	3.5	0.21	220	0	-	2	-20	75	PUR	121V5397 <sub>2</sub>	2995	482740	-	1.6	6.0/8.0	8116	
	3	3.5	0.21	220	0	4.5	4	-20	75	PUR	121V5397 <sub>2</sub>	-	495900	2.5	2	6.0/8.0	8024	
	3	3.5	0.21	220	0	-	4.5	-20	75	PUR	121V5397 <sub>2</sub>	-	495910	*	-	0.3-1.2	6.0/8.0	8024
	3	3.5	0.21	220	0	-	2	-20	65	PUR	121V5397 <sub>2</sub>	2995	496125	-	1.6	6.0/8.0	8116	
	4	7	0.42	450	0	10	4	-10	100	FKM	121V5206	2995	481865	8	9	2.0	8116	
	4	7	0.42	450	0	10	5	-10	120	FKM	121V5206	4270	481000	8	8	2.0	8116	
	4	7	0.42	450	0	10	10	-10	120	FKM	121V5206	4270	486265	14	14	2.0	8116	
	4	7	0.42	450	0	3.5	3.5	0	100	PTFE	121V5212 <sub>1</sub>	2995	481865	8	9	2.0	8116	
	4	7	0.42	450	0	3.5	3.5	0	130	PTFE	121V5212 <sub>1</sub>	4270	481000	8	8	2.0	8116	
	4	7	0.42	450	0	3.5	3.5	0	130	PTFE	121V5212 <sub>1</sub>	4270	486265	14	14	2.0	8116	
	4	7	0.42	450	0	12	4	0	100	Ruby	121V5263 <sub>1</sub>	2995	481865	8	9	2.0	8116	
	4	7	0.42	450	0	15	5	0	130	Ruby	121V5263 <sub>1</sub>	4270	481000	8	8	2.0	8116	
	4	7	0.42	450	0	22	10	0	180	Ruby	121V5263 <sub>1</sub>	4270	486265	14	14	2.0	8116	
	5	10	0.6	750	0	7	2	-10	100	FKM	121V5106	2995	481865	8	9	2.0	8116	
	5	10	0.6	750	0	7	2.8	-10	120	FKM	121V5106	4270	481000	8	8	2.0	8116	
	5	10	0.6	750	0	7	5	-10	120	FKM	121V5106	4270	486265	14	14	2.0	8116	
	5	10	0.6	-	0	2.8	2	0	100	PTFE	121V5112 <sub>1</sub>	2995	481865	8	9	2.0	8116	
	5	10	0.6	-	0	2.8	2.8	0	130	PTFE	121V5112 <sub>1</sub>	4270	481000	8	8	2.0	8116	
5	10	0.6	-	0	2.8	2.8	0	130	PTFE	121V5112 <sub>1</sub>	4270	486265	14	14	2.0	8116		
5	10	0.6	750	0	8.5	2	0	100	Ruby	121V5163 <sub>1</sub>	2995	481865	8	9	2.0	8116		
5	10	0.6	750	0	10	3.5	0	130	Ruby	121V5163 <sub>1</sub>	4270	481000	8	8	2.0	8116		
5	10	0.6	750	0	14	6.5	0	140	Ruby	121V5163 <sub>1</sub>	4270	486265	14	14	2.0	8116		
1/4" NPT	3	4.5	0.27	315	0	10	7	-10	100	FKM	U121V5306	2995	481865	8	9	2.0	8116	
	3	4.5	0.27	315	0	20	7	0	100	Ruby	U121V5363	2995	481865	8	9	2.0	8116	

#### Notes:

1. Valve only compatible with hydraulic oil and neutral liquids
2. Valve compatible with water only up to If fluid is water, temperature shall not exceed 40°C



## 2 WAY VALVES



For this page	Port size	Orifice (mm)	Kv (l/min)	MOPD (bar)	Fluid Temp (°C)
From	1/4"	3	3.5	2	-20
To	1/4"	5	10	22	180

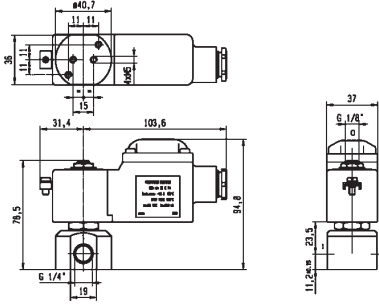

Drawing 8024

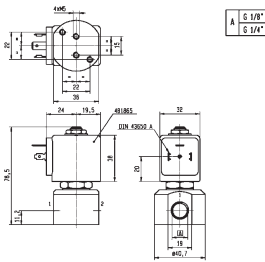

Drawing 8116

## 2 WAY VALVES

# 2/2

## HIGH CORROSION RESISTANT VALVES (303 STAINLESS ST.) DIRECT OPERATED

### 303 STAINLESS ST.

### PIPE MOUNTING

### NORMALLY OPEN

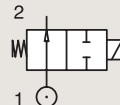

Port size	Orifice Ø	Flow factors			Operating Pressure Differential			Fluid Temp.		Seat Seal	Valve Ref.	Housing Ref.	Coil Ref.	Power		Coil Group	Dwg. No.
		Kv l/min	KV m <sup>3</sup> /h	Qn l/min	Min bar	Max(MOPD) AC bar	DC bar	Min °C	Max °C					AC W	DC W		
1/4"	2.5	3	0.18	180	0	12	12	-30	100	FKM	122V8306	2995	481865	8	9	2.1	8116
	2.5	3	0.18	180	0	12	12	-30	120	FKM	122V8306	4270	481000	8	8	2.1	8116

## 2 WAY VALVES

UK  
CA CE



For this page	Port size	Orifice (mm)	Kv (l/min)	MOPD (bar)	Fluid Temp (°C)
From	1/4"	2.5	3	12	-30
To	1/4"	2.5	3	12	120

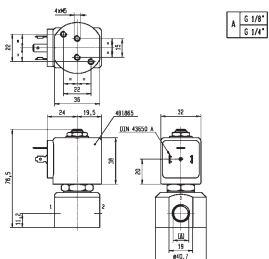

Drawing 8116



## 2 WAY VALVES



### VALVES FOR BEVERAGE DISPENSING AND LIQUIPURE®



# 2/2

Actuation	Body	Function	Port Size	Orifice (mm)	Flow Factor Kv(l/min)	MOPD (bar)	Max Fluid Temp. (°C)	Page Parker Valves
Direct Operated	LLB Brass/Pipe Mounting	Normally Closed	1/8"	1.0 to 3	0.7 a 4.5	20	140	136
	LLB Brass/Pipe Mounting	Normally Closed	1/4"	1.5 to 5	1.5 a 9.5	20	140	138
	LLB Brass/Sub-base Mounting	Normally Closed	SB	1.5 to 3	1.4 a 3.4	20	140	138
	Stainless St./Sub-base Mounting	Normally Closed	SB	1.5 to 3	4.2	20	140	140

## 2 WAY VALVES

# 2/2

# VALVES FOR BEVERAGE DISPENSING AND LIQUIPURE® DIRECT OPERATED

CW510L BRASS BODY  
PIPE MOUNTING

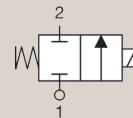

### NORMALLY CLOSED

Port Size	Orifice Ø mm	Flow Factors		Operating Pressure Differential			Fluid Temperature		Seat Seal	Parker Valves			Power		Coil Group	Dwg N°
		Kv l/min	KV m³/h	Min. Bar	Max. (MOPD) DC bar	Min. °C	Max. °C	Valve Ref.		Housing Ref.	Coil Ref.	AC W	DC W			
G1/8"	1.0	0.7	0.04	0	20	18	-10	140	FDA	121ZH1010	2995	481865	9	8	2.0, 2.1, 2.2	1
	1.5	1.5	0.09	0	20	18	-10	140	FDA	121ZH1015	2995	481865	9	8	2.0, 2.1, 2.2	
	2.0	2.6	0.16	0	20	15	-10	140	FDA	121ZH1020	2995	481865	9	8	2.0, 2.1, 2.2	
	2.5	3.5	0.21	0	19	14.5	-10	140	FDA	121ZH1025	2995	481865	9	8	2.0, 2.1, 2.2	
	3.0	4.5	0.27	0	13	8.5	-10	140	FDA	121ZH1030	2995	481865	9	8	2.0, 2.1, 2.2	
	1.0	0.7	0.04	0	20	18	-10	140	Ruby	121ZH0010	2995	481865	9	8	2.0, 2.1, 2.2	
	1.5	1.5	0.09	0	20	18	-10	140	Ruby	121ZH0015	2995	481865	9	8	2.0, 2.1, 2.2	
	2.0	2.6	0.16	0	20	15	-10	140	Ruby	121ZH0020	2995	481865	9	8	2.0, 2.1, 2.2	
	2.5	3.5	0.21	0	19	14.5	-10	140	Ruby	121ZH0025	2995	481865	9	8	2.0, 2.1, 2.2	
	3.0	4.5	0.27	0	13	8.5	-10	140	Ruby	121ZH0030	2995	481865	9	8	2.0, 2.1, 2.2	
NPT 1/8"	1.0	0.7	0.04	0	20	18	-10	140	FDA	U121ZH1010	2995	481865	9	8	2.0, 2.1, 2.2	
	1.5	1.5	0.09	0	20	18	-10	140	FDA	U121ZH1015	2995	481865	9	8	2.0, 2.1, 2.2	
	2.0	2.6	0.16	0	20	15	-10	140	FDA	U121ZH1020	2995	481865	9	8	2.0, 2.1, 2.2	
	2.5	3.5	0.21	0	19	14.5	-10	140	FDA	U121ZH1025	2995	481865	9	8	2.0, 2.1, 2.2	
	3.0	4.5	0.27	0	13	8.5	-10	140	FDA	U121ZH1030	2995	481865	9	8	2.0, 2.1, 2.2	
	1.0	0.7	0.04	0	20	18	-10	140	Ruby	U121ZH0010	2995	481865	9	8	2.0, 2.1, 2.2	
	1.5	1.5	0.09	0	20	18	-10	140	Ruby	U121ZH0015	2995	481865	9	8	2.0, 2.1, 2.2	
	2.0	2.6	0.16	0	20	15	-10	140	Ruby	U121ZH0020	2995	481865	9	8	2.0, 2.1, 2.2	
	2.5	3.5	0.21	0	19	14.5	-10	140	Ruby	U121ZH0025	2995	481865	9	8	2.0, 2.1, 2.2	
	3.0	4.5	0.27	0	13	8.5	-10	140	Ruby	U121ZH0030	2995	481865	9	8	2.0, 2.1, 2.2	

## 2 WAY VALVES



For this page	Port size	Orifice (mm)	Kv (l/min)	MOPD (bar)	Fluid Temp (°C)
From	1/8"	1.5	1.5	2	-10
To	1/4"	4	9.5	20	140
From	SB	1.5	1.4	10	-10
To	SB	3	3.4	20	140

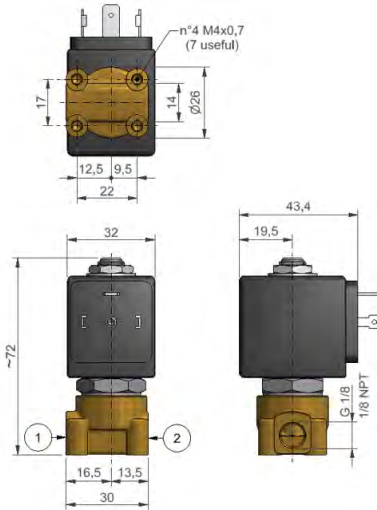

Drawing 1

## 2 WAY VALVES

# 2/2

# VALVES FOR BEVERAGE DISPENSING AND LIQUIPURE®

## DIRECT OPERATED

CW510L BRASS BODY  
PIPE MOUNTING FLANGED (SB)

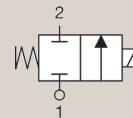

### NORMALLY CLOSED

Port Size	Orifice Ø mm	Flow Factors		Operating Pressure Differential			Fluid Temperature		Seat Seal	Parker Valves			Power		Coil Group	Dwg N°	
		Kv l/min	KV m³/h	Min. Bar	Max. (MOPD) DC bar	Min. °C	Max. °C	Valve Ref.		Housing Ref.	Coil Ref.	AC W	DC W				
G1/4"	1.5	1.5	0.09	0	20	18	-10	140	FDA FKM	121KH1015	2995	481865	9	8	2.0, 2.1, 2.2	1	
	2.0	2.6	0.16	0	20	15	-10	140	FDA FKM	121KH1020	2995	481865	9	8	2.0, 2.1, 2.2		
	2.5	3.5	0.21	0	19	14.5	-10	140	FDA FKM	121KH1025	2995	481865	9	8	2.0, 2.1, 2.2		
	3.0	4.5	0.27	0	13	8.5	-10	140	FDA FKM	121KH1030	2995	481865	9	8	2.0, 2.1, 2.2		
	4.0	5.5	0.33	0	9	6	-10	140	FDA FKM	121KH1040	2995	481865	9	8	2.0, 2.1, 2.2		
	5.0	9.5	0.57	0	2.5	2	-10	140	FDA FKM	121KH1050	2995	481865	9	8	2.0, 2.1, 2.2		
SB	1.5	1.5	0.09	0	20	18	-10	140	Ruby	121KH0015	2995	481865	9	8	2.0, 2.1, 2.2	1	
	2.0	2.6	0.16	0	20	15	-10	140	Ruby	121KH0020	2995	481865	9	8	2.0, 2.1, 2.2		
	2.5	3.5	0.21	0	19	14.5	-10	140	Ruby	121KH0025	2995	481865	9	8	2.0, 2.1, 2.2		
	3.0	4.5	0.27	0	13	8.5	-10	140	Ruby	121KH0030	2995	481865	9	8	2.0, 2.1, 2.2		
	1.5	1.4	0.08	0	20	20	-10	140	FDA FKM	121FH1015	2995	481865	9	8	2.0, 2.1, 2.2		3
	2.0	2.3	0.14	0	20	20	-10	140	FDA FKM	121FH1020	2995	481865	9	8	2.0, 2.1, 2.2		
2.5	3.0	0.18	0	20	14	-10	140	FDA FKM	121FH1025	2995	481865	9	8	2.0, 2.1, 2.2			
3.0	3.4	0.2	0	17	10	-10	140	FDA FKM	121FH1030	2995	481865	9	8	2.0, 2.1, 2.2			
1.5	1.4	0.08	0	20	20	-10	140	Ruby	121FH0015	2995	481865	9	8	2.0, 2.1, 2.2			
2.0	2.3	0.14	0	20	20	-10	140	Ruby	121FH0020	2995	481865	9	8	2.0, 2.1, 2.2			
	2.5	3.0	0.18	0	20	14	-10	140	Ruby	121FH0025	2995	481865	9	8	2.0, 2.1, 2.2		
	3.0	3.4	0.2	0	17	10	-10	140	Ruby	121FH0030	2995	481865	9	8	2.0, 2.1, 2.2		



For this page	Port size	Orifice (mm)	Kv (l/min)	MOPD (bar)	Fluid Temp (°C)
From	1/8"	1.5	1.5	2	-10
To	1/4"	4	9.5	20	140
From	SB	1.5	1.4	10	-10
To	SB	3	3.4	20	140

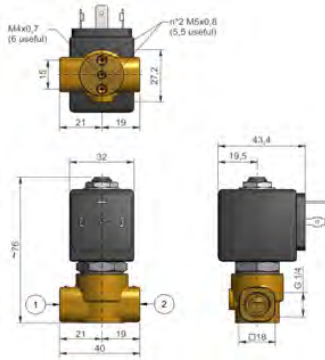

Drawing 1

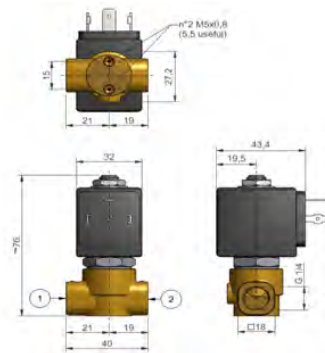

Drawing 2

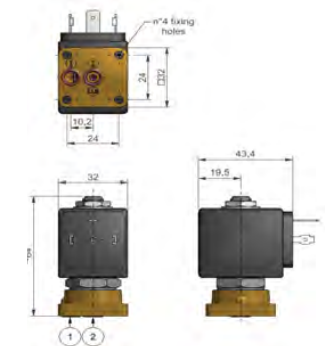

Drawing 3

## 2 WAY VALVES

# 2/2

## VALVES FOR BEVERAGE DISPENSING - LIQUIPURE® DIRECT OPERATED

STAINLESS ST.  
SUB-BASE MOUNTING

**NORMALLY CLOSED**

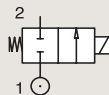

Port size	Orifice Ø mm	Flow factors			Operating Pressure Differential			Fluid Temp.		Seat Seal	Valve Ref.	Parker Valves		Power		Coil Group	Dwg. No.	Compatible adapter kit
		Kv l/min	KV m³/h	Qn l/min	Min bar	Max(MOPD) AC bar	DC bar	Min °C	Max °C			Housing Ref.	Coil Ref.	AC W	DC W			
SB	1.5	1.3	0.08	-	0	20	20	-10	140	Ruby	2019F1GRG7	-	481865	8	9	2.0	071	XGSPG1-XGSPG2
	1.5	1.3	0.08	-	0	20	20	-10	140	FKM FDA	2019F1GVG7	-	481865	8	9	2.0	071	XGSPG1-XGSPG2
	2	2.3	0.14	-	0	15	15	-10	140	Ruby	2019F1JRG7	-	481865	8	9	2.0	071	XGSPG1-XGSPG2
	2	2.3	0.14	-	0	15	15	-10	140	FKM FDA	2019F1JVG7	-	481865	8	9	2.0	071	XGSPG1-XGSPG2
	2.5	3.2	0.19	-	0	10	10	-10	140	FKM FDA	2019F1LRG7	-	481865	8	9	2.0	071	XGSPG1-XGSPG2
	2.5	3.2	0.19	-	0	10	10	-10	140	FKM FDA	2019F1LVG7	-	481865	8	9	2.0	071	XGSPG1-XGSPG2
	3	4.2	0.25	-	0	7	7	-10	140	Ruby	2019F1NRG7	-	481865	8	9	2.0	071	XGSPG1-XGSPG2
	3	4.2	0.25	-	0	7	7	-10	140	FKM FDA	2019F1NVG7	-	481865	8	9	2.0	071	XGSPG1-XGSPG2
	4	6.5	0.39	-	0	5	5	-10	140	FKM FDA	2019F1QVG7	-	481865	9	8	2.0	071	XGSPG3
	4	6.5	0.39	-	0	5	5	-10	140	EPDM	2019F1QEG7	-	481865	9	8	2.0	071	XGSPG3
5	7.2	0.43	-	0	3	3	-10	140	FKM FDA	2019F1SVG7	-	481865	9	8	2.0	071	XGSPG3	
5	7.2	0.43	-	0	3	3	-10	140	EPDM	2019F1SEG7	-	481865	9	8	2.0	071	XGSPG3	

Important: pressure vessels included in this page are supplied with the standard 2995 housing integrated.

## 2 WAY VALVES



For this page	Port size	Orifice (mm)	Kv (l/min)	MOPD (bar)	Fluid Temp (°C)
From	SB	1.5	1.3	3	-10
To	SB	5	7.2	20	140

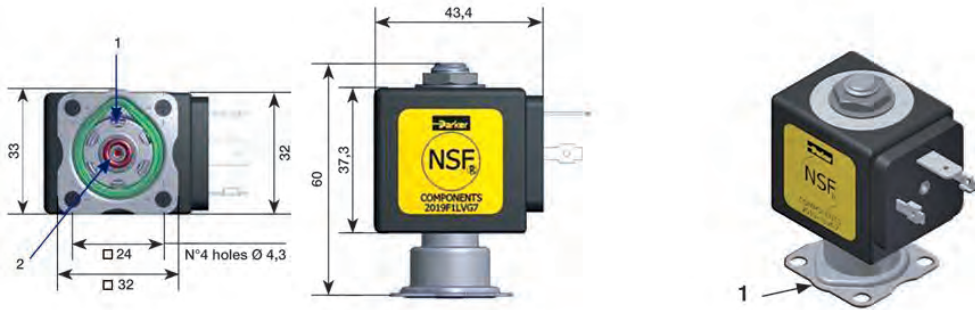

Drawing 071



## 2 WAY VALVES



### HIGH CORROSION RESISTANT VALVES (316L STAINLESS ST.)



# 2/2

Actuation	Body	Function	Port Size	Orifice (mm)	Flow Factor Kv(l/min)	MOPD (bar)	Max Fluid Temp. (°C)	Page Parker Valves
Direct Operated	316L Stainless St./Pipe Mounting	Normally Closed	1/8"	1.5 to 2.5	2.3	20	140	144
		Normally Open	1/4"	1.5 to 3	6	20	140	144
			1/2"	3	10	4	140	144
			3/8"	5 to 6.2	10	4	140	144
			1/4"	1	0.6	98	75	148
Direct Operated	316L Stainless St./Pipe Mounting	Normally Open	1/4"	3.0 to 5	8	6	140	146
		1/2"	5.0 to 6.2	10	3	140	146	
Magnalift	316L Stainless St./Pipe Mounting	Normally Closed	3/8"	15	65	20	140	150
			1/2"	15	80	20	140	150
			3/4"	15	80	20	140	152
			1"	25	160	16	120	152

## 2 WAY VALVES

# 2/2

## HIGH CORROSION RESISTANT VALVES 201LG SERIES DIRECT OPERATED

316L STAINLESS ST.  
PIPE MOUNTING

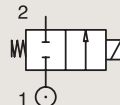

### NORMALLY CLOSED

Port size	Orifice Ø	Flow factors			Operating Pressure Differential			Fluid Temp.		Seat Seal	Valve Ref.	Housing Ref.	Coil Ref.	Power		Coil Group	Dwg. No.
		Kv l/min	KV m <sup>3</sup> /h	Qn l/min	Min bar	Max(MOPD) DC bar	Min °C	Max °C	AC W					DC W			
1/8"	1.5	1	0.06	-	0	20	15	-10	140	FKM	201LG1GVG2	-	481180	4	5	1.1/1.3	074
	2.5	2.3	0.14	-	0	10	6	-10	140	FKM	201LG1LVG2	-	481180	4	5	1.1/1.3	074
1/4"	1.5	1	0.06	-	0	20	15	-10	140	FKM	201LG2GVG2	-	481180	4	5	1.1/1.3	075
	2.5	2.3	0.14	-	0	10	6	-10	140	FKM	201LG2LVG2	-	481180	4	5	1.1/1.3	075
3/8"	3	4.5	0.27	-	0	8	5	-10	140	FKM	201LG2NVG7	-	481865	8	9	2.0	076
	5	8	0.48	-	0	3	2	-10	140	FKM	201LG3SVG7	-	481865	8	9	2.0	077
1/2"	6.2	10	0.6	-	0	1.5	0.5	-10	140	FKM	201LG3UVG7	-	481865	8	9	2.0	077
	5	8	0.48	-	0	3	2	-10	140	FKM	201LG4SVG7	-	481865	8	9	2.0	078
1/2"	6.2	10	0.6	-	0	1.5	0.5	-10	140	FKM	201LG4UVG7	-	481865	8	9	2.0	078

## 2 WAY VALVES



For this page	Port size	Orifice (mm)	Kv (l/min)	MOPD (bar)	Fluid Temp (°C)
From	1/8"	1.5	1	5	-10
To	1/2"	6.2	10	20	140

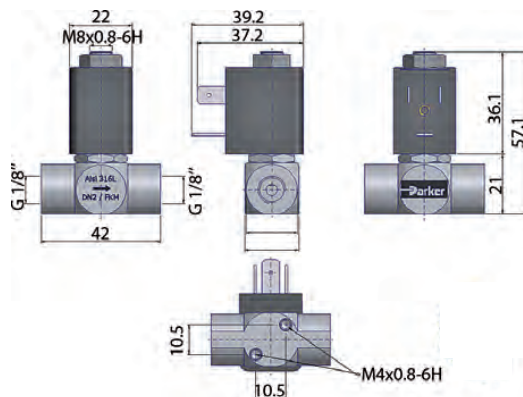

Drawing 074

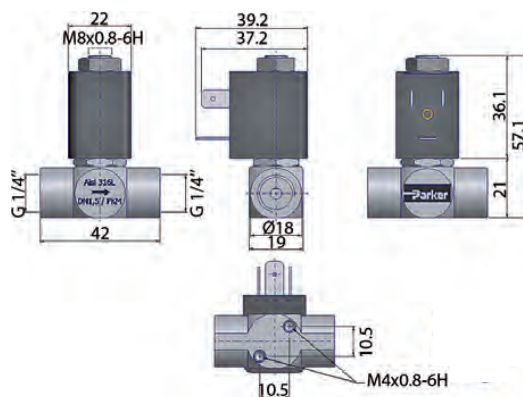

Drawing 075

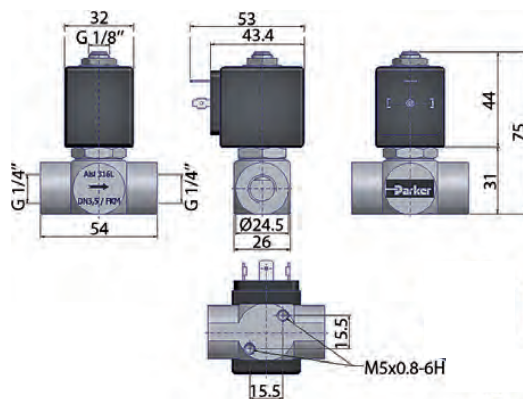

Drawing 076

## 2 WAY VALVES

# 2/2

## HIGH CORROSION RESISTANT VALVES 202LG SERIES DIRECT OPERATED

316L STAINLESS ST.  
PIPE MOUNTING

**NORMALLY OPEN**

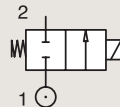

Port size	Orifice Ø	Flow factors		Operating Pressure Differential			Fluid Temp.		Seat Seal	Valve Ref.	Coil Ref.	Power		Coil Group	Dwg. No.
		Kv l/min	KV m <sup>3</sup> /h	Min bar	Max(MOPD) AC bar	DC bar	Min °C	Max °C				AC W	DC W		
1/4"	3.0	4.5	0.27	0	6	6	-10	140	FKM	202LG2N7G7	481865	8	9	24/2.0	3
	5.0	8.0	0.48	0	3	3	-10	140	FKM	202LG2S7G7	481865	8	9	24/2.0	3
1/2"	5.0	8.0	0.48	0	3	3	-10	140	FKM	202LG4S7G7	481865	8	9	24/2.0	3
	6.2	10.0	0.60	0	1	1	-10	140	FKM	202LG4U7G7	481865	8	9	24/2.0	3

## 2 WAY VALVES



For this page	Port size	Orifice (mm)	Kv (l/min)	MOPD (bar)	Fluid Temp (°C)
From	1/4"	3	4.5	1	-10
To	1/2"	6.2	10	6	140

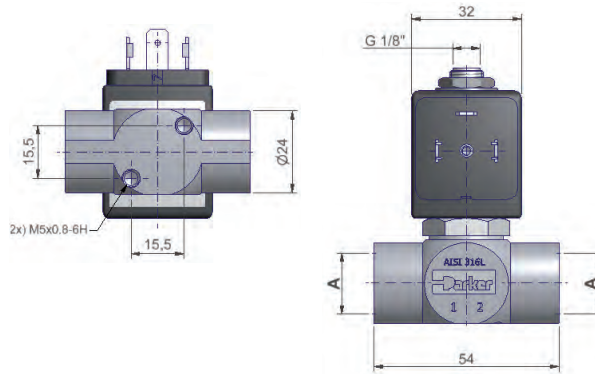

Drawing 3

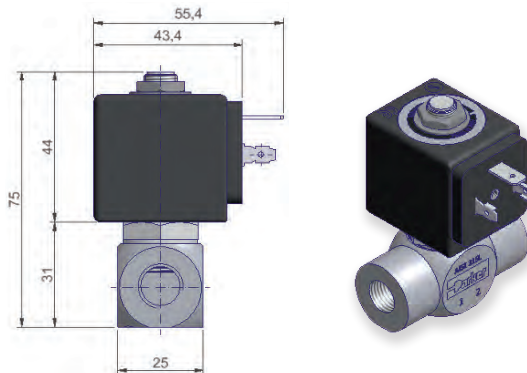

Drawing 3

## 2 WAY VALVES

# 2/2

## HIGH CORROSION RESISTANT VALVES V SERIES DIRECT OPERATED

316L STAINLESS ST.  
PIPE MOUNTING

**NORMALLY CLOSED**

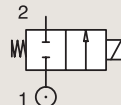

Port size	Orifice Ø mm	Flow factor			Operating Pressure Differential			Fluid Temp.		Seat Seal	Valve Ref.	Housing Ref.	Coil Ref.	ATEX Zone	Protection Mode	Power		Coil Group	Dwg. No.
		Kv l/min	KV m <sup>3</sup> /h	Qn l/min	Min bar	AC bar	DC bar	Min °C	Max °C							AC W	DC W		
1/4" NPT	0.8	-	-	20	0	-	200	-25	65	PUR	U121VS3750A <sub>1</sub>	-	496565	0-20	Ex ia IIC T4 to T6	-	0.3	9.0/10.1/10.2	8165
	0.8	-	-	20	0	-	200	-25	75	PUR	U121VS3750A <sub>1</sub>	-	492210	1-21	Ex eb mb IIC T5 to T6	-	1 to 1.8	9.0/10.1/10.2	6713
	0.8	-	-	20	0	200	200	-25	75	PUR	U121VS3750A <sub>1</sub>	-	492310	1-21	Ex mb II T4 to T5	6	6	9.0/10.1/10.2	6713
	0.8	-	-	20	0	200	200	-25	65	PUR	U121VS3750A <sub>1</sub>	-	496560	1-21	Ex db mb IIC T4	8	8	9.0/10.1/10.2	8165
	0.8	-	-	20	0	200	200	-25	65	PUR	U121VS3750A <sub>1</sub>	-	496800	1-21	Ex db mb IIC T4	8	8	9.0/10.1/10.2	8165
	1	0.6	0.04	40	0	-	98	-40	75	PUR	U121V5595 <sub>23</sub>	-	496565	0-20	Ex ia IIC T4 to T6	-	0.3	9.0/10.1/10.2	8165
	1	0.6	0.04	40	0	-	98	-40	75	PUR	U121V5595 <sub>23</sub>	-	492210	1-21	Ex eb mb IIC T5 to T6	-	1 to 1.8	9.0/10.1/10.2	6713
	1	0.6	0.04	40	0	98	98	-40	65	PUR	U121V5595 <sub>23</sub>	-	496800	1-21	Ex db mb IIC T4	8	8	9.0/10.1/10.2	8165
	1	0.6	0.04	40	0	98	98	-40	75	PUR	U121V5595 <sub>23</sub>	-	492310	1-21	Ex mb II T4 to T5	6	6	9.0/10.1/10.2	6713
	1	0.6	0.04	40	0	98	98	-40	65	PUR	U121V5595 <sub>23</sub>	-	496560	1-21	Ex db mb IIC T4	8	8	9.0/10.1/10.2	8165
	1	0.6	0.04	40	0	98	98	-40	50	PUR	U121V5595 <sub>23</sub>	-	496895	-	-	8	8	9.0/10.1/10.2	8165
	1	0.6	0.04	40	0	-	98	-40	65	PUR	U121V7595 <sub>3</sub>	-	496565	0-20	Ex ia IIC T4 to T6	-	0.3	9.0/10.1/10.2/10.3	8165
	1	0.6	0.04	40	0	98	98	-40	65	PUR	U121V7595 <sub>3</sub>	-	496800	1-21	Ex db mb IIC T4	8	8	9.0/10.1/10.2/10.3	8165
	1	0.6	0.04	40	0	98	98	-40	65	PUR	U121V7595 <sub>3</sub>	-	497105	1-21	Ex db IIC T4 to T6	8	8	9.0/10.1/10.2/10.3	8299
	1	0.6	0.04	40	0	98	98	-40	50	PUR	U121V7595 <sub>3</sub>	-	496895	-	-	8	8	9.0/10.1/10.2/10.3	8165

**Notes:**

1. Valve only compatible with neutral gases
2. Valve delivered with an individual material traceability certificate (2.2 following EN10204)
3. Valve compatible with water only up to 40°C

## 2 WAY VALVES



For this page	Port size	Orifice (mm)	Kv (l/min)	MOPD (bar)	Fluid Temp (°C)
From	1/4"	1	0.6	98	-40
To	1/4"	1	0.6	98	75

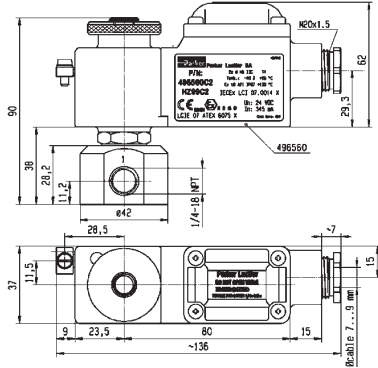

Drawing 8165

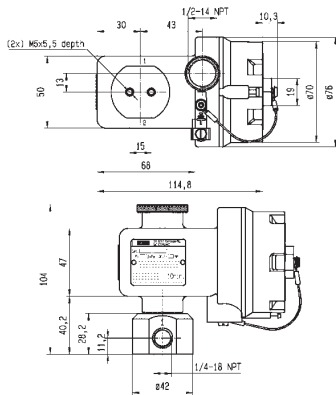

Drawing 8299

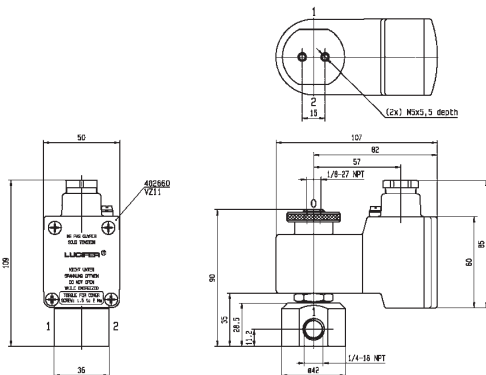

Drawing 6713

## 2 WAY VALVES

# 2/2

## HIGH CORROSION RESISTANT VALVES 221G SERIES MAGNALIFT

### 316L STAINLESS ST. - SILVER SHADIN RING PIPE MOUNTING

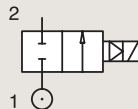

### NORMALLY CLOSED

Port Size	Orifice Ø mm	Flow Factors Kv l/min	Kv m³/h	Operating Pressure Differential Max. (MOPD)			Fluid Temperature		Seat Seal	Parker Valves			IS	ATEX Zone	Protection Mode	Power		Coil Group	Dwg N°
				Min. Bar	AC bar	DC bar	Min. °C	Max. °C		Valve Ref.	Housing Ref.	Coil Ref.				AC W	DC W		
3/8"	15	65	3.90	0	16	-	-10	100	FKM	221G6306	2995	481865	-	-	-	8	-	2.0	3732
	15	65	3.90	0	20	5	-10	100	FKM	221G6306	2995	492425	-	-	-	14	14	2.0	3732
	15	65	3.90	0	16	-	-10	65	FKM	221G6306	2995	495870	-	2-22	Ex nAc nCc IIC T3/T4	8	-	2.0	3732
	15	65	3.90	0	16	-	-10	120	FKM	221G6306	4270	481000	-	-	-	8	-	2.0	3732
	15	65	3.90	0	20	7	-10	140	FKM	221G6306	4270	486265	-	-	-	14	14	2.0	3732
	15	65	3.90	0	16	-	-10	80	FKM	221G6306	-	495905	-	1-21	Ex db mb IIC T4	8	-	2.0	3732
	15	65	3.90	0	-	10	-10	100	FKM	221G6336 <sub>1</sub>	2995	481865	-	-	-	-	9	2.1	3732
	15	65	3.90	0	-	10	-10	65	FKM	221G6336 <sub>1</sub>	2995	495870	-	2-22	Ex nAc nCc IIC T3/T4	-	9	2.1	3732
	15	65	3.90	0	10	10	-10	65	FKM	221G6336 <sub>1</sub>	-	492070	-	1-21	Ex mb IIC T4/T5	9	8	2.1	3732
	15	65	3.90	0	10	10	-10	75	FKM	221G6336 <sub>1</sub>	-	492190	-	1-21	Ex eb mb IIC T3/T4	11	9	2.1	3732
	15	65	3.90	0	-	10	-10	80	FKM	221G6336 <sub>1</sub>	-	495905	-	1-21	Ex db mb IIC T4	-	8	2.1	3732
	15	65	3.90	0	10	-	-10	100	EPDM	221G6307	2995	481865	-	-	-	8	-	2.0	3732
	15	65	3.90	0	10	-	-10	65	EPDM	221G6307	2995	495870	-	2-22	Ex nAc nCc IIC T3/T4	8	-	2.0	3732
	15	65	3.90	0	10	-	-10	120	EPDM	221G6307	4270	481000	-	-	-	8	-	2.0	3732
	15	65	3.90	0	10	7	-10	140	EPDM	221G6307 <sub>2</sub>	4270	486265	-	-	-	14	14	2.0	3732
15	65	3.90	0	10	-	-10	80	EPDM	221G6307	-	495905	-	1-21	Ex db mb IIC T4	8	-	2.0	3732	
1/2"	15	80	4.80	0	16	-	-10	100	FKM	221G6506	2995	481865	-	-	-	8	-	2.0	3732
	15	80	4.80	0	20	5	-10	100	FKM	221G6506	2995	492425	-	-	-	14	14	2.0	3732
	15	80	4.80	0	16	-	-10	65	FKM	221G6506	2995	495870	-	2-22	Ex nAc nCc IIC T3/T4	8	-	2.0	3732
	15	80	4.80	0	16	-	-10	120	FKM	221G6506	4270	481000	-	-	-	8	-	2.0	3732
	15	80	4.80	0	20	7	-10	140	FKM	221G6506	4270	486265	-	-	-	14	14	2.0	3732
	15	80	4.80	0	16	-	-10	80	FKM	221G6506	-	495905	-	1-21	Ex db mb IIC T4	8	-	2.0	3732
	15	80	4.80	0	-	10	-10	100	FKM	221G6536 <sub>1</sub>	2995	481865	-	-	-	-	9	2.1	3732
	15	80	4.80	0	-	10	-10	65	FKM	221G6536 <sub>1</sub>	2995	495870	-	2-22	Ex nAc nCc IIC T3/T4	-	9	2.1	3732
	15	80	4.80	0	10	10	-10	65	FKM	221G6536 <sub>1</sub>	-	492070	-	1-21	Ex mb IIC T4/T5	9	8	2.1	3732
	15	80	4.80	0	10	10	-10	75	FKM	221G6536 <sub>1</sub>	-	492190	-	1-21	Ex eb mb IIC T3/T4	11	9	2.1	3732
	15	80	4.80	0	-	10	-10	80	FKM	221G6536 <sub>1</sub>	-	495905	-	1-21	Ex db mb IIC T4	-	8	2.1	3732
	15	80	4.80	0	10	-	-10	100	EPDM	221G6507	2995	481865	-	-	-	8	-	2.0	3732
	15	80	4.80	0	10	-	-10	65	EPDM	221G6507	2995	495870	-	2-22	Ex nAc nCc IIC T3/T4	8	-	2.0	3732
	15	80	4.80	0	10	-	-10	120	EPDM	221G6507	4270	481000	-	-	-	8	-	2.0	3732
	15	80	4.80	0	10	7	-10	140	EPDM	221G6507 <sub>2</sub>	4270	486265	-	-	-	14	14	2.0	3732
15	80	4.80	0	10	-	-10	80	EPDM	221G6507	-	495905	-	1-21	Ex db mb IIC T4	8	-	2.0	3732	

Notes:

- Without shading ring
- Maximum pressure for steam: 4 bar (140°C)



## 2 WAY VALVES



For this page	Port size	Orifice (mm)	Kv (l/min)	MOPD (bar)	Fluid Temp (°C)
From	3/8"	15	65	6	-10
To	1/2"	15	80	20	140

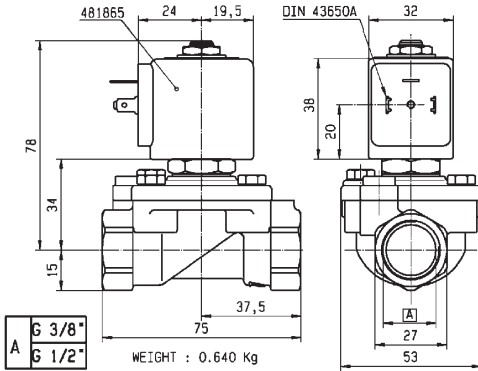

Drawing 3732

## 2 WAY VALVES

# 2/2

## HIGH CORROSION RESISTANT VALVES 221G SERIES MAGNALIFT

### 316L STAINLESS ST. - SILVER SHADIN RING

#### PIPE MOUNTING

#### NORMALLY CLOSED

Port Size	Orifice Ø mm	Flow Factors		Operating Pressure Differential Max. (MOPD)			Fluid Temperature		Seal	Parker Valves			IS	ATEX Zone	Protection Mode	Power		Coil Group	Dwg N°
		Kv l/min	KV m³/h	Min. Bar	Max. AC bar	DC bar	Min. °C	Max. °C		Valve Ref.	Housing Ref.	Coil Ref.				AC W	DC W		
3/4"	15	80	4.80	0	16	-	-10	100	FKM	221G6606	2995	481865	-	-	-	8	-	2.0	8451
	15	80	4.80	0	20	5	-10	60	FKM	221G6606	2995	492425	-	-	-	14	14	2.0	8451
	15	80	4.80	0	16	-	-10	65	FKM	221G6606	2995	495870	-	2-22	Ex nAc nCc IIC T3/T4	8	-	2.0	8451
	15	80	4.80	0	16	-	-10	120	FKM	221G6606	4270	481000	-	-	-	8	-	2.0	8451
	15	80	4.80	0	20	7	-10	140	FKM	221G6606	4270	486265	-	-	-	14	14	2.0	8451
	15	80	4.80	0	16	-	-10	80	FKM	221G6606	-	495905	-	1-21	Ex db mb IIC T4	8	-	2.0	8451
	15	80	4.80	0	-	10	-10	100	FKM	221G6636 <sub>1</sub>	2995	481865	-	-	-	-	9	2.1	8451
	15	80	4.80	0	-	10	-10	65	FKM	221G6636 <sub>1</sub>	2995	495870	-	2-22	Ex nAc nCc IIC T3/T4	-	9	2.1	8451
	15	80	4.80	0	10	10	-10	65	FKM	221G6636 <sub>1</sub>	-	492070	-	1-21	Ex mb IIC T4/T5	9	8	2.1	8451
	15	80	4.80	0	10	10	-10	75	FKM	221G6636 <sub>1</sub>	-	492190	-	1-21	Ex eb mb IIC T3/T4	11	9	2.1	8451
	15	80	4.80	0	-	10	-10	80	FKM	221G6636 <sub>1</sub>	-	495905	-	1-21	Ex db mb IIC T4	-	8	2.1	8451
	15	80	4.80	0	10	-	-10	100	EPDM	221G6607	2995	481865	-	-	-	8	-	2.0	8451
	15	80	4.80	0	10	-	-10	65	EPDM	221G6607	2995	495870	-	2-22	Ex nAc nCc IIC T3/T4	8	-	2.0	8451
	15	80	4.80	0	10	-	-10	120	EPDM	221G6607	4270	481000	-	-	-	8	-	2.0	8451
	15	80	4.80	0	10	7	-10	140	EPDM	221G6607 <sub>2</sub>	4270	486265	-	-	-	14	14	2.0	8451
15	80	4.80	0	10	-	-10	80	EPDM	221G6607	-	495905	-	1-21	Ex db mb IIC T4	8	-	2.0	8451	
1"	25	160	9.60	0	16	-	-10	100	FKM	221G6106	2995	481865	-	-	-	8	-	2.0	3448
	25	160	9.60	0	20	5	-10	60	FKM	221G6106	2995	492425	-	-	-	14	14	2.0	3448
	25	160	9.60	0	16	-	-10	65	FKM	221G6106	2995	495870	-	2-22	Ex nAc nCc IIC T3/T4	8	-	2.0	3448
	25	160	9.60	0	16	6	-10	120	FKM	221G6106	4270	486265	-	-	-	14	14	2.0	3448
	25	160	9.60	0	16	-	-10	80	FKM	221G6106	-	495905	-	1-21	Ex db mb IIC T4	8	-	2.0	3448
	25	160	9.60	0	-	10	-10	100	FKM	221G6136 <sub>1</sub>	2995	481865	-	-	-	-	9	2.0	3448
	25	160	9.60	0	-	10	-10	65	FKM	221G6136 <sub>1</sub>	2995	495870	-	2-22	Ex nAc nCc IIC T3/T4	-	9	2.0	3448
	25	160	9.60	0	-	10	-10	100	FKM	221G6136 <sub>1</sub>	4270	481000	-	-	-	-	8	2.0	3448
	25	160	9.60	0	-	10	-10	80	FKM	221G6136 <sub>1</sub>	-	495905	-	1-21	Ex db mb IIC T4	-	8	2.0	3448
	25	160	9.60	0	10	-	-10	100	EPDM	221G6107	2995	481865	-	-	-	8	---	2.0	8448
	25	160	9.60	0	10	-	-10	65	EPDM	221G6107	2995	495870	-	2-22	Ex nAc nCc IIC T3/T4	8	-	2.0	8448
	25	160	9.60	0	10	-	-10	120	EPDM	221G6107	4270	481000	-	-	-	8	---	2.0	8448
	25	160	9.60	0	10	10	-10	140	EPDM	221G6107 <sub>2</sub>	4270	486265	-	-	-	14	14	2.0	8448
	25	160	9.60	0	10	-	-10	80	EPDM	221G6107	-	495905	-	1-21	Ex db mb IIC T4	8	-	2.0	8448

Notes:

1. Without shading ring
2. Maximum pressure for steam: 4 bar (140°C)



## 2 WAY VALVES



For this page	Port size	Orifice (mm)	Kv (l/min)	MOPD (bar)	Fluid Temp (°C)
From	3/4"	15	80	6	-10
To	1"	25	160	20	140

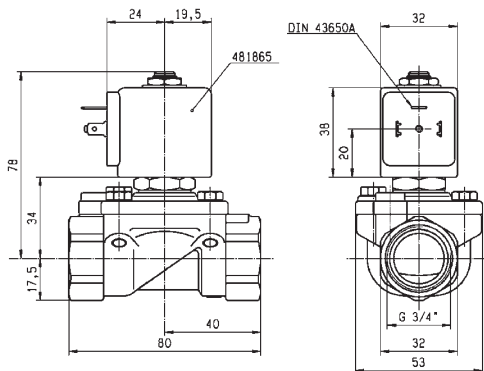

Drawing 8451

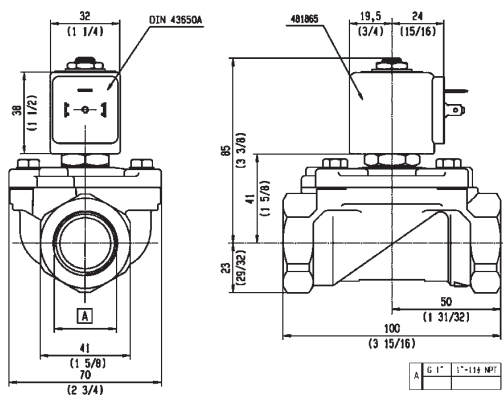

Drawing 8448



## 2 WAY VALVES

### OIL BURNER VALVES



# 2/2

Actuation	Body	Function	Port Size	Orifice (mm)	Flow Factor Kv(l/min)	MOPD (bar)	Max Fluid Temp. (°C)	Page Parker Valves
Direct Operated	Brass/Pipe Mounting	Normally Closed	1/8"	3	4	30	160	156
			1/4"	3	4	30	160	156
			3/8"	6 to 11	22	30	160	156
			1/2"	14	25	30	160	156
	Brass/Pipe Mounting	Normally Open	1/8"	2.5	3.5	30	160	158
			1/4"	2.5	3.5	30	160	158
	Brass/Sub-base Mounting	Normally Closed	SB	2.5	3.5	30	160	158
Magnalift	Brass/Pipe Mounting	Normally Closed	1/2"	15	50	5	140	160
Pilot Operated	Brass/Pipe Mounting	Normally Closed	1/4"	8	36	40	140	162
			3/8"	11	50	40	160	162
			1/2"	15	60	40	160	164
Pilot Operated	Brass/Sub-base Mounting	Normally Closed	14 mm	14	45	30	160	164

## 2 WAY VALVES

# 2/2

## OIL BURNER VALVES

### DIRECT OPERATED

BRASS

PIPE MOUNTING

**NORMALLY CLOSED**

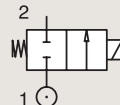

Port size	Orifice Ø	Flow factors			Operating Pressure Differential			Fluid Temp.		Seat Seal	Valve Ref.	Housing Ref.	Coil Ref.	Power		Coil Group	Dwg. No.
		Kv l/min	KV m³/h	Qn l/min	Min bar	Max(MOPD) DC bar	Min °C	Max °C	AC W					DC W			
1/8"	2.2	2.8	0.17	-	0	25	-	-10	120	Ruby	121Z2323	299522	483764	9	-	14.2	7863
	3	4	0.24	-	0	30	-	-30	160	Ruby	121K2423 <sub>1</sub>	852023	483824	19	-	14.1	3292
1/4"	3	4.5	0.27	-	0	30	-	-30	160	Ruby	121K6423 <sub>1</sub>	852023	483824	19	-	14.1	3292
	4	6.5	0.39	-	0	30	-	0	160	Ruby	121K6220 <sub>1</sub>	852023	483541	20	-	14.3	3510
3/8"	6	12	0.72	-	0	5	-	0	120	Ruby	121K3321 <sub>1</sub>	2995	492425	14	-	14.1	3551
	11	22	1.32	-	0	30	-	0	160	FKM	121G2320 <sub>12</sub>	852023	483541	20	-	14.3	3646
1/2"	14	25	1.5	-	0	30	-	0	160	FKM	121G2520 <sub>12</sub>	852023	483541	20	-	14.3	3646
	14	25	1.5	-	0	30	-	0	160	FKM	121G2523 <sub>12</sub>	852023	483824	19	-	14.1	3646

**Notes:**

- DIN-EN-ISO 23553-1:2014-09 approved for oil burners
- Max. Static pressure = 30 bar; max pressure differential = 0.2 bar

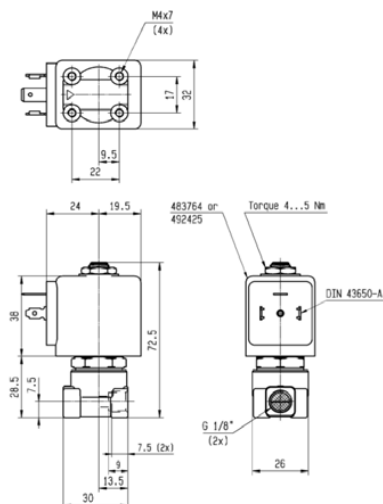

Drawing 7863



## 2 WAY VALVES



For this page	Port size	Orifice (mm)	Kv (l/min)	MOPD (bar)	Fluid Temp (°C)
From	1/8"	3	4	5	-30
To	1/2"	14	25	30	160

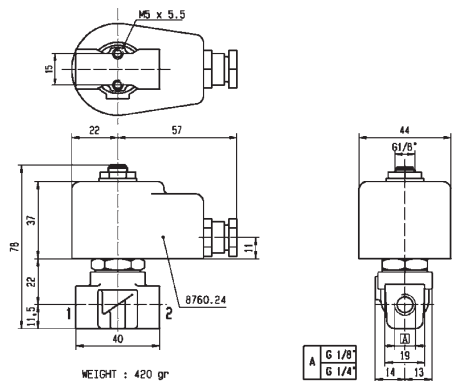

Drawing 3292

VALVE	A
321863	G 3/8"
321865	G 1/2"

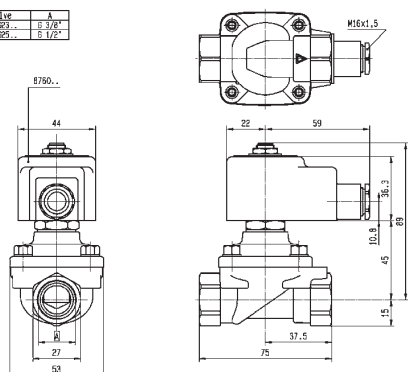

Drawing 3646

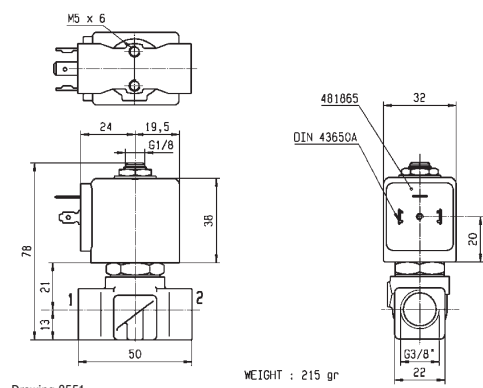

Drawing 3551

WEIGHT : 215 gr

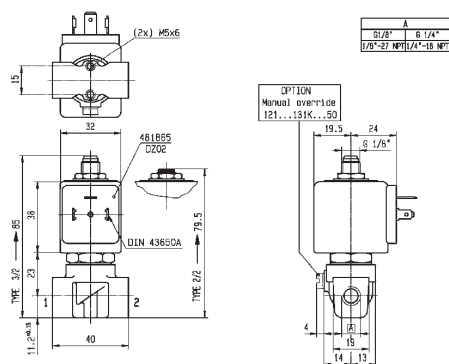

Drawing 3510



## 2 WAY VALVES

# 2/2

## OIL BURNER VALVES

### DIRECT OPERATED

#### BRASS

#### PIPE MOUNTING

#### NORMALLY OPEN

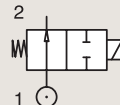

Port size	Orifice Ø	Flow factors			Operating Pressure Differential			Fluid Temp.		Seat Seal	Valve Ref.	Housing Ref.	Coil Ref.	Power		Coil Group	Dwg. No.
		Kv l/min	KV m <sup>3</sup> /h	Qn l/min	Min bar	Max(MOPD) DC bar	Min °C	Max °C	AC W					DC W			
1/8"	2.5	3.5	0.21	-	0	30	-	-30	160	Ruby	122K9321 <sub>1</sub>	852023	483824	19	-	14.1	6766
1/4"	2.5	3.5	0.21	-	0	30	-	-30	160	Ruby	122K8321 <sub>1</sub>	852023	483824	19	-	14.1	6766

**Notes:**

1.DIN-EN-ISO 23553-1:2014-09 approved for oil burners

#### BRASS

#### SUB-BASE MOUNTING

#### NORMALLY CLOSED

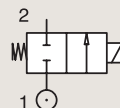

Port size	Orifice Ø	Flow factors			Operating Pressure Differential			Fluid Temp.		Seat Seal	Valve Ref.	Housing Ref.	Coil Ref.	Power		Coil Group	Dwg. No.
		Kv l/min	KV m <sup>3</sup> /h	Qn l/min	Min bar	Max(MOPD) DC bar	Min °C	Max °C	AC W					DC W			
SB	14	25	1.5	-	0	30	-	0	160	FKM	121F2523 <sub>1</sub>	852023	483824	19	-	14.1	7638

**Notes:**

1.DIN-EN-ISO 23553-1:2014-09 approved for oil burners

## 2 WAY VALVES

UK  
PAK CE

For this page	Port size	Orifice (mm)	Kv (l/min)	MOPD (bar)	Fluid Temp (°C)
From	1/8"	2.5	3.5	30	-30
To	SB	14	25	30	160

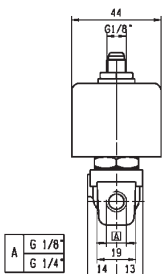
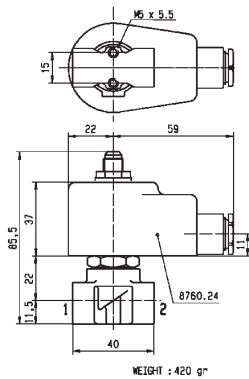

Drawing 6766

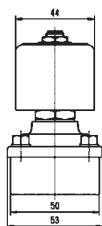
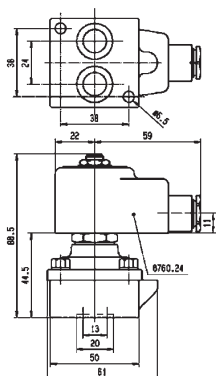

Drawing 7638

2 WAY VALVES

**2/2**

OIL BURNER VALVES  
MAGNALIFT

BRASS

PIPE MOUNTING

NORMALLY CLOSED

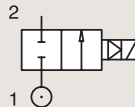

Port size	Orifice Ø	Flow factors			Operating Pressure Differential			Fluid Temp.		Seat Seal	Valve Ref.	Housing Ref.	Coil Ref.	Power		Coil Group	Dwg. No.
		Kv l/min	KV m³/h	Qn l/min	Min bar	Max(MOPD) AC bar	DC bar	Min °C	Max °C					AC W	DC W		
1/2"	15	50	3	-	0	5	-	0	140	FKM	221G2523	852023	483824	19	-	14.1	8298

Notes:

1.DIN-EN-ISO 23553-1:2014-09 approved for oil burners



## 2 WAY VALVES

UK  
CA CE



For this page	Port size	Orifice (mm)	Kv (l/min)	MOPD (bar)	Fluid Temp (°C)
From	1/2"	15	50	5	0
To	1/2"	15	50	5	140

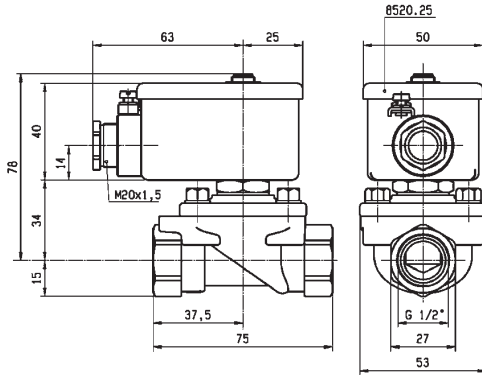

Drawing 8298

## 2 WAY VALVES

# 2/2

## OIL BURNER VALVES

### PILOT OPERATED

BRASS

PIPE MOUNTING

NORMALLY CLOSED

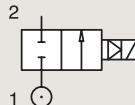

Port size	Orifice Ø	Flow factors			Operating Pressure Differential			Fluid Temp.		Seat Seal	Valve Ref.	Housing Ref.	Coil Ref.	Power		Coil Group	Dwg. No.
		Kv l/min	KV m³/h	Qn l/min	Min bar	Max(MOPD) DC bar	Min °C	Max °C	AC W					DC W			
1/4"	8	36	2.16	-	0.3	40	25	-10	100	FKM	E321H21 <sup>23</sup>	2995	481865	8	9	2.0	3523
	8	36	2.16	-	0.3	40	30	-10	120	FKM	E321H21 <sup>23</sup>	4270	481000	8	8	2.0	3523
	8	36	2.16	-	0.3	40	40	-10	140	FKM	E321H21 <sup>23</sup>	4270	486265	14	14	2.0	3523
3/8"	11	40	2.4	-	0.3	30	-	0	160	Ruby	321H2322 <sup>12</sup>	852023	483541	20	-	14.1	3633
	11	50	3	-	0.3	40	25	-10	100	FKM	E321H23 <sup>23</sup>	2995	481865	8	9	2.0	3521
	11	50	3	-	0.3	40	30	-10	120	FKM	E321H23 <sup>23</sup>	4270	481000	8	8	2.0	3521
	11	50	3	-	0.3	40	40	-10	140	FKM	E321H23 <sup>23</sup>	4270	486265	14	14	2.0	3521

**Notes:**

- DIN-EN-ISO 23553-1:2014-09 approved for oil burners
- Minimum pressure differential = 0.3 bar for opening and 0 bar for closing
- Pilot seat disc in synthetic Ruby



## 2 WAY VALVES



For this page	Port size	Orifice (mm)	Kv (l/min)	MOPD (bar)	Fluid Temp (°C)
From	1/4"	8	36	25	-10
To	3/8"	11	50	40	160

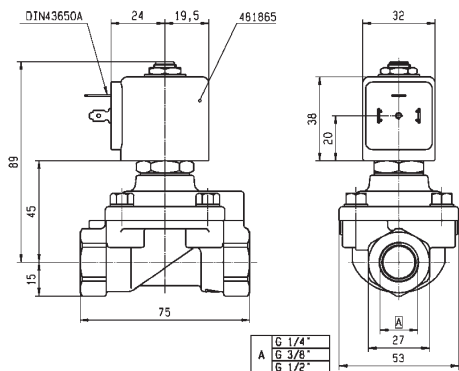

Drawing 3523

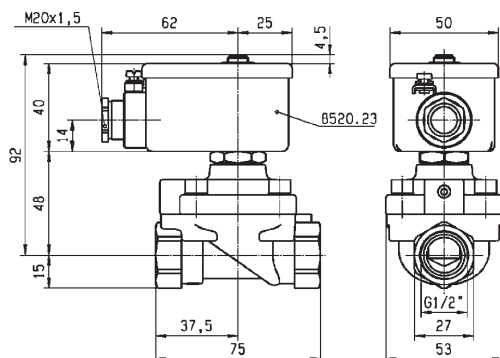

Drawing 3633

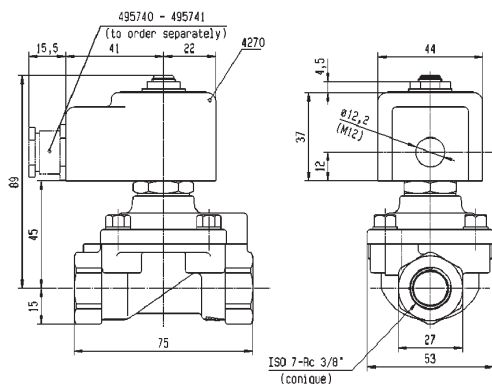

Drawing 3521



## 2 WAY VALVES

# 2/2

## OIL BURNER VALVES

### PILOT OPERATED

#### BRASS

#### PIPE MOUNTING

#### NORMALLY CLOSED

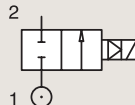

Port size	Orifice Ø	Flow factors			Operating Pressure Differential			Fluid Temp.		Seat Seal	Valve Ref.	Housing Ref.	Coil Ref.	Power		Coil Group	Dwg. No.
		Kv l/min	KV m³/h	Qn l/min	Min bar	Max(MOPD) DC bar	Min °C	Max °C	AC W					DC W			
1/2"	15	60	3.6	-	0.3	30	-	0	160	Ruby	321H2522 <sub>1</sub>	852023	483541	20	-	14.1	3633
	15	60	3.6	-	0.3	30	-	0	160	Ruby	321H2523 <sub>1</sub>	852023	483824	19	-	14.1	3633
	15	60	3.6	-	0.3	40	25	-10	100	FKM	E321H25 <sub>23</sub>	2995	481865	8	9	2.0/14.2	3522
	15	60	3.6	-	0.3	40	30	-10	65	FKM	E321H25 <sub>23</sub>	-	483371	8	8	2.0/14.2	3522
	15	60	3.6	-	0.3	40	40	-10	140	FKM	E321H25 <sub>23</sub>	4270	486265	14	14	2.0/14.2	3522

**Notes:**

- DIN-EN-ISO 23553-1:2014-09 approved for oil burners
- Minimum pressure differential = 0.3 bar for opening and 0 bar for closing
- Pilot seat disc in synthetic Ruby

#### BRASS

#### SUB-BASE MOUNTING

#### NORMALLY CLOSED

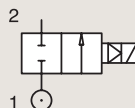

Port size	Orifice Ø	Flow factors			Operating Pressure Differential			Fluid Temp.		Seat Seal	Valve Ref.	Housing Ref.	Coil Ref.	Power		Coil Group	Dwg. No.
		Kv l/min	KV m³/h	Qn l/min	Min bar	Max(MOPD) DC bar	Min °C	Max °C	AC W					DC W			
SB	14	45	2.7	-	0	30	-	0	160	FKM	321F2523 <sub>12</sub>	852023	483824	19	-	14.1	7639

**Notes:**

- DIN-EN-ISO 23553-1:2014-09 approved for oil burners
- Minimum pressure differential = 0.3 bar for opening and 0 bar for closing

## 2 WAY VALVES



For this page	Port size	Orifice (mm)	Kv (l/min)	MOPD (bar)	Fluid Temp (°C)
From	1/2"	14	45	25	-10
To	14 mm	15	60	40	160

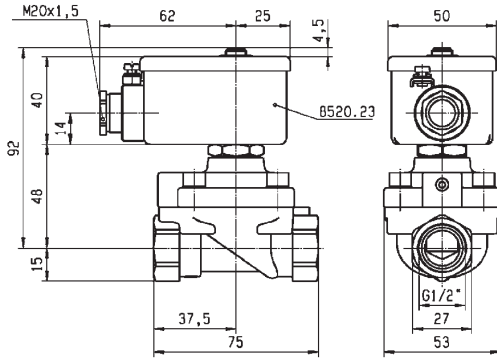

Drawing 3633

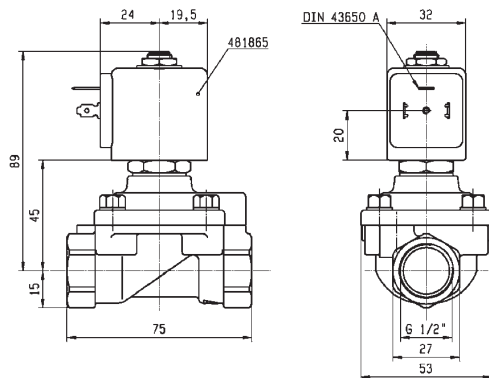

Drawing 3522

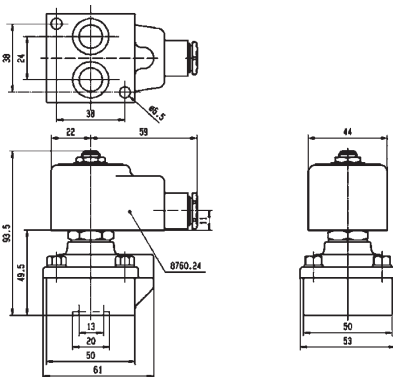

Drawing 7639





## 2 WAY VALVES

### FAST SWITCHING VALVES



# 2/2

Actuation	Body	Function	Port Size	Orifice (mm)	Flow Factor Kv(l/min)	MOPD (bar)	Max Fluid Temp. (°C)	Page Parker Valves
Magnalift	Brass/Pipe Mounting	Normally Closed	3/8"	8	0	7	40	168

## 2 WAY VALVES

# 2/2

## FAST SWITCHING VALVES

### MAGNALIFT

BRASS

PIPE MOUNTING

NORMALLY CLOSED

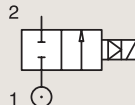

Port size	Orifice Ø	Flow factors			Operating Pressure Differential			Fluid Temp.		Seat Seal	Valve Ref.	Housing Ref.	Coil Ref.	Power		Coil Group	Dwg. No.
		Kv l/min	KV m³/h	Qn l/min	Min bar	Max(MOPD) AC bar	DC bar	Min °C	Max °C					AC W	DC W		
3/8"	8			-	0	-	7	0	40	PUR	221J3301E	29956	483816	-	14		8020

**Notes:**

1. For more details, please consult catalogue 8674UK

Flow rate (valve on 100%)

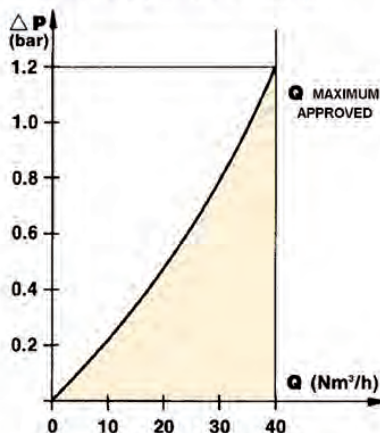

## 2 WAY VALVES

UK  
CA CE

For this page	Port size	Orifice (mm)	Kv (l/min)	MOPD (bar)	Fluid Temp (°C)
From	3/8"	8	-	7	0
To	3/8"	8	-	7	40

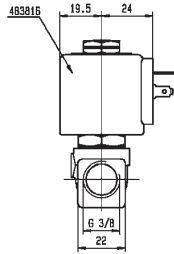
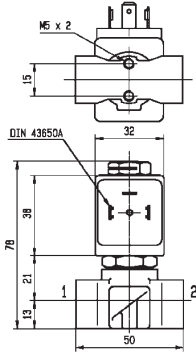

Drawing 8020



## 3 WAY VALVES



# VALVES FOR DRY OR LUBRICATED AIR, NEUTRAL GASES AND LIQUIDS



# 3/2

Actuation	Body	Function	Port Size	Orifice (mm)	Flow Factor Kv(l/min)	MOPD (bar)	Max Fluid Temp. (°C)	Page Parker Valves
Direct Operated	Brass/Pipe Mounting	Normally Closed	1/8"	1.2 to 2.5	3.5	15	120	172
			1/4"	1 to 4.5	7	15	120	172 to 178
		Normally Open	1/4"	1.5 to 3	4.5	16	120	180
			Universal	1/8"	1.5 to 2.5	3.5	10	140
		Control by Electric Impulse	1/4"	0.8 to 3	4.5	30	140	182 and 184
			1/4"	1.5	1.5	16	100	184
	Brass/Sub-base Mounting	Normally Closed	SB	1 to 2.5	3.5	15	140	186 and 188
		Normally Open	SB	1.5 to 2.5	2.2	15	120	188
		Universal	SB	1.5 to 2.5	2.5	10	120	190
	Anodized Aluminium/Banjo	Normally Closed	1/8"	1.2	-	10	50	192
			1/4"	1.2	-	10	50	192
	316L Stainless St./Sub-base Mounting	Normally Closed	SB	1.5	1.5	15	100	194
			POM/Sub-base Mounting	SB	2	2	10	50
Stainless St./Sub-base Mounting	Normally Closed	SB	1.5 to 5	7.2	14	140	198	
		Universal	SB	1.5 to 3	3.3	9.5	140	200
Pilot Operated	Anodized Aluminium/Pipe Mounting	Normally Closed	1/4"	6.5 to 8	20	15	75	202
			1/2"	14	-	15	75	204
		Normally Open	1/4"	8	20	40	75	204
			1/2"	14	-	15	75	206
	Anodized Aluminium/Sub-base Mounting/Poppet	Normally Closed	SB	15	-	10	75	206

### 3 WAY VALVES

# 3/2

## VALVES FOR DRY OR LUBRICATED AIR, NEUTRAL GASES AND LIQUIDS DIRECT OPERATED

### BRASS

### PIPE MOUNTING

### NORMALLY CLOSED

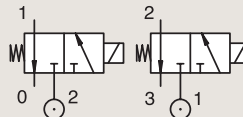

Port size	Orifice Ø		Flow factors				Operating Pressure Differential			Fluid Temp.		Seat Seal	Valve Ref.	Housing Ref.	Coil Ref.	IS Power		Coil Group	Dwg. No.	
	1	(2)	1	(2)	1	(2)	Min	Max (MOPD)	Min	Max	AC W					DC W				
BSP	mm		Kv	l/min	KV	m <sup>3</sup> /h	bar	AC bar	DC bar	°C	°C									
1/8"	1.2	1.5	0.7	0.9	0.04	0.05	0	10	10	-10	75	FKM	131M15	8993	488980	2	2.5	1.1	3382	
	1.2	1.5	0.7	0.9	0.04	0.05	0	10	10	-10	75	FKM	131M1550 <sub>1</sub>	8993	488980	2	2.5	1.1	3382	
	1.5	1.5	0.9	0.9	0.05	0.05	0	7	7	-10	75	FKM	131M14	8993	488980	2	2.5	1.1	3382	
	1.5	1.5	1.5	1.5	0.09	0.09	0	15	15	-10	120	FKM	E131K14	4270	481000	8	8	2.1	3510	
	1.5	1.5	1.5	1.5	0.09	0.09	0	15	15	-10	100	FKM	E131K14	2995	481865	8	9	2.1	3510	
	2	2.5	2.5	3.5	0.15	0.21	0	10	10	-10	120	FKM	131K16	4270	481000	8	8	2.1	3510	
	2	2.5	2.5	3.5	0.15	0.21	0	10	10	-10	100	FKM	131K16	2995	481865	8	9	2.1	3510	
	2	2.5	2.5	3.5	0.15	0.21	0	10	10	-10	120	FKM	131K1650 <sub>1</sub>	4270	481000	8	8	2.1	3510	
	2	2.5	2.5	3.5	0.15	0.21	0	10	10	-10	100	FKM	131K1650 <sub>1</sub>	2995	481865	8	9	2.1	3510	
	2	2.5	2.5	3.5	0.15	0.21	0	10	10	-10	100	FKM	131K1650 <sub>1</sub>	2995	481865	8	9	2.1	3510	
1/8"-1/4"	2.5	2.5	3.5	3.5	0.21	0.21	0	7	7	-10	120	FKM	E131K13	4270	481000	8	8	2.0	3510	
	2.5	2.5	3.5	3.5	0.21	0.21	0	7	7	-10	100	FKM	E131K13	2995	481865	8	9	2.0	3510	
	2.5	2.5	3.5	3.5	0.21	0.21	0	7	7	-10	100	FKM	E131K13	4270	486265	14	14	2.0	3510	
	2.5	2.5	3	3	0.18	0.18	0	-	2	-20	75	PUR	131K0397	2995	482740	-	1.6	6.0/8.0	8023	
1/4"	2.5	2.5	3	3	0.18	0.18	0	2	2	-20	75	PUR	131K0397	-	495900	2.5	2	6.0/8.0	8023	
	2.5	2.5	3	3	0.18	0.18	0	-	2	-20	75	PUR	131K0397	-	495910	*	-	0.3 to 3	6.0/8.0	8023
	1	1	0.6	0.6	0.03	0.03	0	-	10	-10	55	FKM	131K0490	2995	483580.01	*	-	0.5 to 3	7.0/8.0	7058
1/4"	1	1	0.6	0.6	0.03	0.03	0	-	10	-10	75	FKM	131K0490	-	48860.01	*	-	0.3 to 3	7.0/8.0	7058
	1	1	0.6	-	0.03	-	0	-	10	-10	75	FKM	131K0490	-	495910	*	-	0.3 to 3	7.0/8.0	7058

#### Notes:

1. With manual override

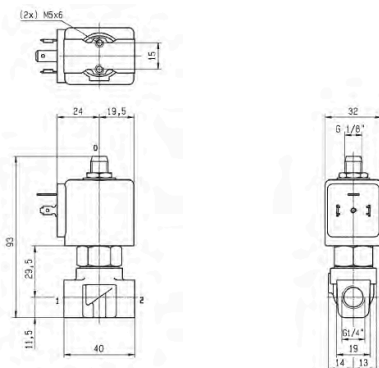

Drawing 7058



### 3 WAY VALVES



For this page	Port size	Orifice (mm)	Kv (l/min)	MOPD (bar)	Fluid Temp (°C)
From	1/8"	1.2	0.7	7	-10
To	1/8"	2.5	3.5	15	120

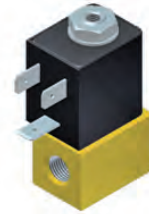
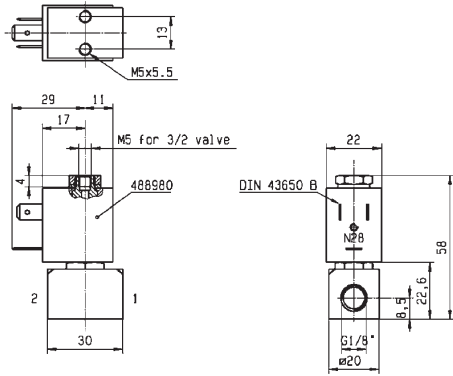

Drawing 3382

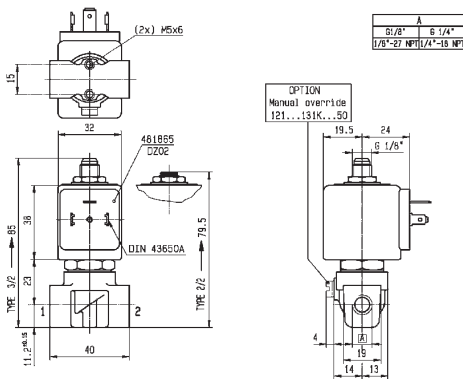

Drawing 3510

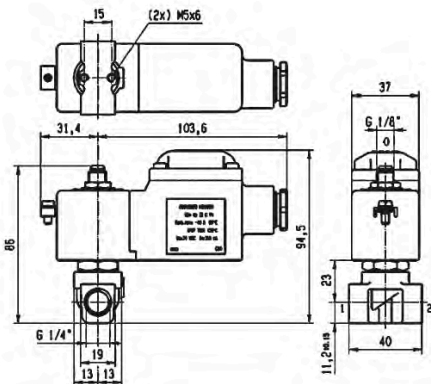

Drawing 8023



### 3 WAY VALVES

# 3/2

## VALVES FOR DRY OR LUBRICATED AIR, NEUTRAL GASES AND LIQUIDS DIRECT OPERATED

### BRASS

### PIPE MOUNTING

### NORMALLY CLOSED

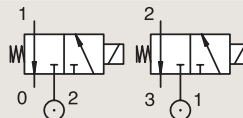

Port size	Orifice Ø		Flow factors			Operating Pressure Differential			Fluid Temp.		Seat Seal	Valve Ref.	Housing Ref.	Coil Ref.	IS		Coil Group	Dwg. No.	
	1	(2)	1	(2)	1	(2)	Min	Max (MOPD)	Min	Max					AC W	DC W			
BSP	mm		Kv l/min		KV m³/h		AC bar	DC bar	°C	°C									
1/4"	1.2	1.5	0.8	1.5	0.05	0.09	0	30	-	-30	130	Ruby	E131K64	4270	481000	8	-	2.0	3510
	1.2	1.5	0.8	1.5	0.05	0.09	0	30	30	-30	140	Ruby	E131K64	4270	486265	14	14	2.0	3510
	1.2	1.5	0.8	1.5	0.05	0.09	0	30	-	-30	130	Ruby	E131K6450	4270	481000	8	-	2.0	3510
	1.2	1.5	0.8	1.5	0.05	0.09	0	30	30	-30	140	Ruby	E131K6450	4270	486265	14	14	2.0	3510
	1.5	1.5	1.5	1.5	0.09	0.09	0	-	7	-20	75	PUR	131K0497	2995	482740	-	1.6	6.0/8.0	8023
	1.5	1.5	1.5	1.5	0.09	0.09	0	7	7	-20	75	PUR	131K0497	-	495900	2.5	2	6.0/8.0	8023
	1.5	1.5	1.5	1.5	0.09	0.09	0	-	7	-20	75	PUR	131K0497	-	495910	*	0.3-1.2	6.0/8.0	8023
	1.5	1.5	1.5	1.5	0.09	0.09	0	-	7	-20	65	PUR	131K0497	2995	496125	-	1.6	6.0/8.0	8023
	1.5	1.5	1.5	1.5	0.09	0.09	0	16	16	-10	120	FKM	E131K04	4270	481000	8	8	2.0	3510
	1.5	1.5	1.5	1.5	0.09	0.09	0	16	16	-10	100	FKM	E131K04	2995	481865	8	9	2.0	3510
	1.5	1.5	1.5	1.5	0.09	0.09	0	16	16	-10	120	FKM	E131K04	4270	486265	14	14	2.0	3510
	1.5	1.5	1.5	1.5	0.09	0.09	0	15	15	-10	120	FKM	E131K0450	4270	481000	8	8	2.1	3510
	1.5	1.5	1.5	1.5	0.09	0.09	0	15	15	-10	100	FKM	E131K0450	2995	481865	8	9	2.1	3510
	2	3	2.5	4.5	0.15	0.27	0	10	10	-10	75	FKM	131T23	4270	481000	8	8	2.0	3223
	2	3	2.5	4.5	0.15	0.27	0	10	10	-10	75	FKM	131T23	2995	481865	8	9	2.0	3223
	2	3	2.5	4.5	0.15	0.27	0	10	10	-10	75	FKM	131T23	4270	486265	14	14	2.0	3223
	2	3	2.5	4.5	0.15	0.27	0	10	10	-10	75	FKM	131T2301	4270	481000	8	8	2.0	3223
	2	3	2.5	4.5	0.15	0.27	0	10	10	-10	75	FKM	131T2301	2995	481865	8	9	2.0	3223
2	3	2.5	4.5	0.15	0.27	0	10	10	-10	75	FKM	131T2301	4270	486265	14	14	2.0	3223	

Notes:

1. With manual override



### 3 WAY VALVES



For this page	Port size	Orifice (mm)	Kv (l/min)	MOPD (bar)	Fluid Temp (°C)
From	1/4"	1	0.6	7	-30
To	1/4"	2	2.5	30	140

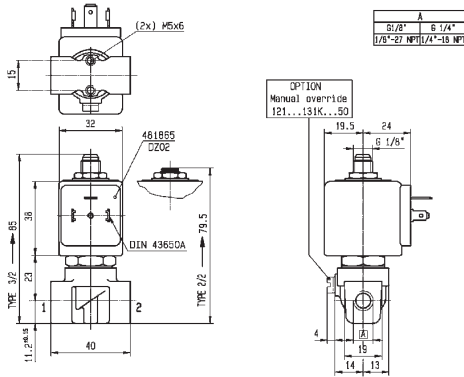

Drawing 3510

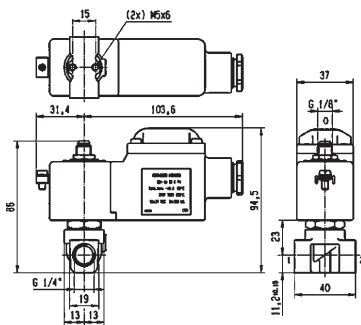

Drawing 8023

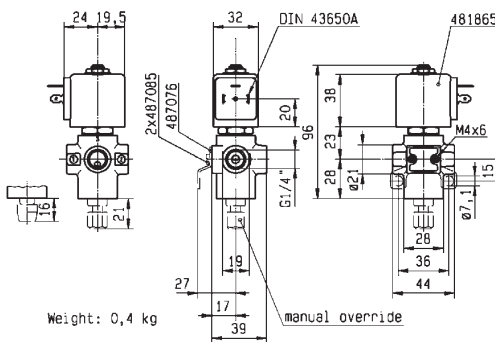

Drawing 3223

### 3 WAY VALVES

# 3/2

## VALVES FOR DRY OR LUBRICATED AIR, NEUTRAL GASES AND LIQUIDS DIRECT OPERATED

### BRASS

### PIPE MOUNTING

### NORMALLY CLOSED

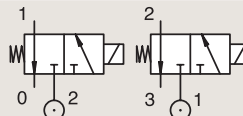

Port size	Orifice Ø		Flow factors				Operating Pressure Differential			Fluid Temp.		Seat Seal	Valve Ref.	Housing Ref.	Coil Ref.	IS		Coil Group	Dwg. No.
	1	(2)	1	(2)	1	(2)	Min	Max (MOPD)		Min	Max					AC W	DC W		
								bar	AC bar										
1/4"	2	2.5	2.5	3.5	0.15	0.21	0	10	10	-10	120	FKM	E131K06	4270	481000	8	8	2.0	8119
	2	2.5	2.5	3.5	0.15	0.21	0	10	10	-10	100	FKM	E131K06	2995	481865	8	9	2.0	8119
	2	2.5	2.5	3.5	0.15	0.21	0	10	10	-10	120	FKM	E131K06	4270	486265	14	14	2.0	8119
	2	2.5	2.5	3.5	0.15	0.21	0	10	10	-10	120	FKM	E131K0650	4270	481000	8	8	2.1	3510
	2	2.5	2.5	3.5	0.15	0.21	0	10	10	-10	100	FKM	E131K0650	2995	481865	8	9	2.1	3510
	2.5	2.5	3	3	0.18	0.18	0	-	2	-20	75	PUR	131K0397	2995	482740	-	1.6	6.0/8.0	8023
	2.5	2.5	3	3	0.18	0.18	0	-	2	-20	65	PUR	131K0397	2995	496125	-	1.6	6.0/8.0	8023
	2.5	2.5	3	3	0.18	0.18	0	2	2	-20	75	PUR	131K0397	-	495900	2.5	2	6.0/8.0	8023
	2.5	2.5	3	3	0.18	0.18	0	-	2	-20	75	PUR	131K0397	-	495910	*	0.3-1.2	6.0/8.0	8023
	2.5	2.5	3.5	3.5	0.21	0.21	0	7	7	-40	75	PUR	E131K0358	4270	481000	8	8	2.1	3510
	2.5	2.5	3.5	3.5	0.21	0.21	0	7	7	-40	75	PUR	E131K0358	2995	481865	8	9	2.1	3510
	2.5	3.5	3.5	5.5	0.21	0.33	0	7	7	-10	75	FKM	131T29	4270	481000	8	8	2.1	3223
	2.5	3.5	3.5	5.5	0.21	0.33	0	7	7	-10	75	FKM	131T29	2995	481865	8	9	2.1	3223
	2.5	3.5	3.5	5.5	0.21	0.33	0	7	7	-10	75	FKM	131T2901	4270	481000	8	8	2.1	3223
	2.5	3.5	3.5	5.5	0.21	0.33	0	7	7	-10	75	FKM	131T2901	2995	481865	8	9	2.1	3223

#### Notes:

1. With manual override

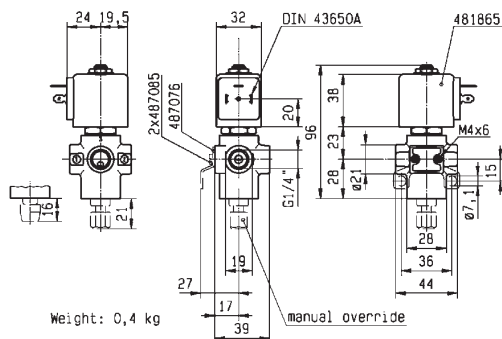

Drawing 3223



### 3 WAY VALVES



For this page	Port size	Orifice (mm)	Kv (l/min)	MOPD (bar)	Fluid Temp (°C)
From	1/4"	2	2.5	2	-40
To	1/4"	2.5	3.5	10	120

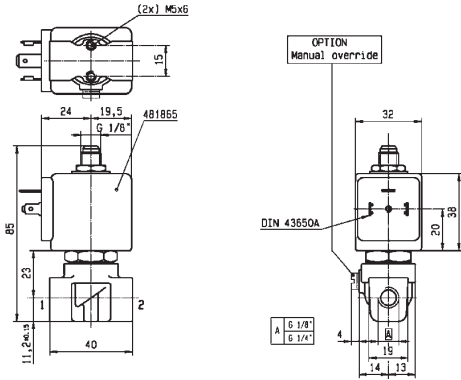

Drawing 8119

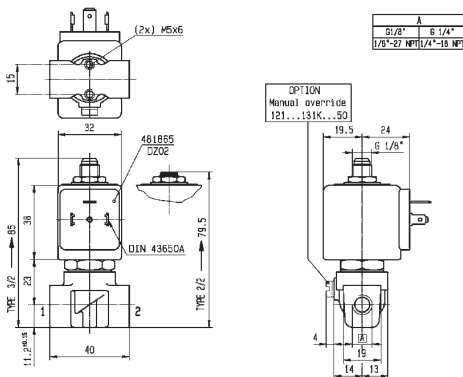

Drawing 3510

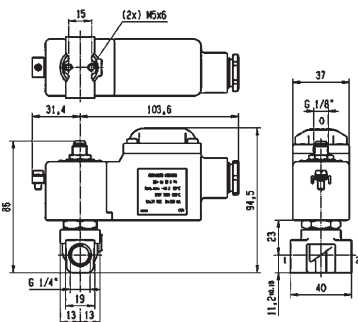

Drawing 8023



### 3 WAY VALVES

# 3/2

## VALVES FOR DRY OR LUBRICATED AIR, NEUTRAL GASES AND LIQUIDS DIRECT OPERATED

### BRASS

### PIPE MOUNTING

### NORMALLY CLOSED

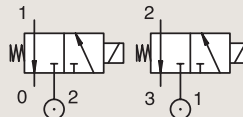

Port size	Orifice Ø		Flow factors			Operating Pressure Differential			Fluid Temp.		Seat Seal	Valve Ref.	Housing Ref.	Coil Ref.	IS		Coil Group	Dwg. No.	
	1	(2)	1	(2)	1	(2)	Min	Max (MOPD)	Min	Max					AC W	DC W			
BSP	mm		Kv l/min		KV m³/h		AC bar	DC bar	°C	°C									
1/4"	2.5	6	2.7	15	0.16	0.9	0.1	7	7	-10	75	FKM	E131E03	4270	481000	8	8	2.0	3525
	2.5	6	2.7	15	0.16	0.9	0.1	7	7	-10	75	FKM	E131E03	2995	481865	8	9	2.0	3525
	2.5	6	2.7	15	0.16	0.9	0.1	7	7	-10	75	FKM	E131E03	4270	486265	14	14	2.0	3525
	2.5	2.5	3.5	3.5	0.21	0.21	0	7	7	-10	100	FKM	E131K03	4270	481000	8	8	2.0	3510
	2.5	2.5	3.5	3.5	0.21	0.21	0	7	7	-10	100	FKM	E131K03	2995	481865	8	9	2.0	3510
	2.5	2.5	3.5	3.5	0.21	0.21	0	7	7	-40	75	PUR	E131K0308	4270	481000	8	8	2.1	3510
	2.5	2.5	3.5	3.5	0.21	0.21	0	7	7	-40	75	PUR	E131K0308	2995	481865	8	9	2.1	3510
	2.5	2.5	3.5	3.5	0.21	0.21	0	7	7	-10	120	FKM	E131K0350	4270	481000	8	8	2.1	3510
	2.5	2.5	3.5	3.5	0.21	0.21	0	7	7	-10	100	FKM	E131K0350	2995	481865	8	9	2.1	3510
	2.5	2.5	3.5	3.5	0.21	0.21	0	7	7	-30	130	Ruby	E131K63	4270	481000	8	8	2.0	3510
	2.5	2.5	3.5	3.5	0.21	0.21	0	7	7	-30	100	Ruby	E131K63	2995	481865	8	9	2.0	3510
	2.5	2.5	3.5	3.5	0.21	0.21	0	7	7	-30	130	Ruby	E131K6350	4270	481000	8	8	2.1	3510
	2.5	2.5	3.5	3.5	0.21	0.21	0	7	7	-30	100	Ruby	E131K6350	2995	481865	8	9	2.1	3510
	3	4	4.5	6	0.27	0.36	0	10	-	-10	75	FKM	131T22	4270	481044	14	-	2.2	3223
	3	4	4.5	6	0.27	0.36	0	10	-	-10	75	FKM	131T22	2995	492425	14	-	2.2	3223
	4.5	6	7	9	0.42	0.54	0	2	2	-10	75	FKM	131T21	4270	481000	8	8	2.0	3223
4.5	6	7	9	0.42	0.54	0	2	2	-10	75	FKM	131T21	2995	481865	8	9	2.0	3223	
4.5	6	7	9	0.42	0.54	0	2	2	-10	75	FKM	131T21	4270	486265	14	14	2.0	3223	

Notes:

1. With manual override



### 3 WAY VALVES



For this page	Port size	Orifice (mm)	Kv (l/min)	MOPD (bar)	Fluid Temp (°C)
From	1/4"	2.5	2.7	2	-40
To	1/4"	4.5	7	10	130

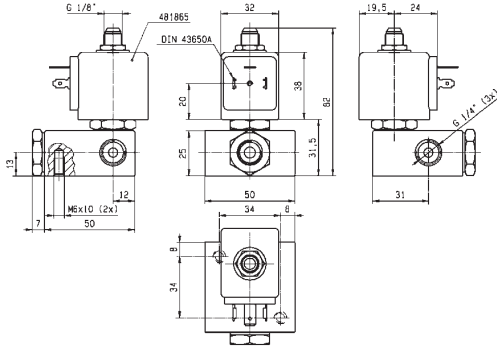

Drawing 3525

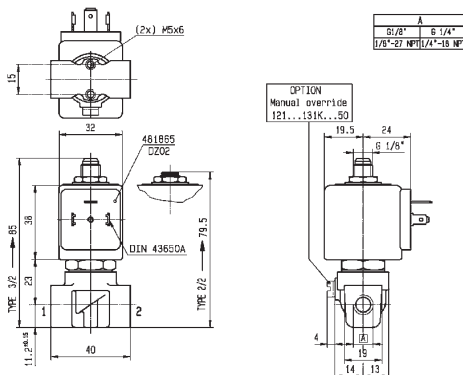

Drawing 3510

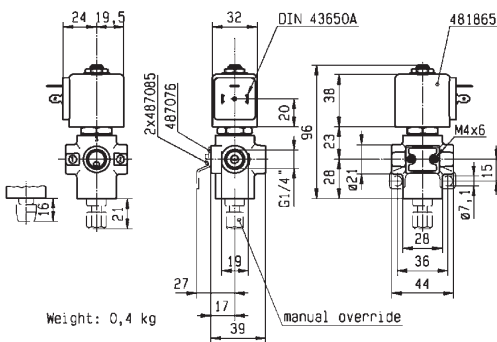

Weight: 0,4 kg



Drawing 3223

### 3 WAY VALVES

# 3/2

## VALVES FOR DRY OR LUBRICATED AIR, NEUTRAL GASES AND LIQUIDS DIRECT OPERATED

### BRASS

### PIPE MOUNTING

### NORMALLY OPEN

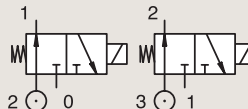

Port size	Orifice Ø		Flow factors			Operating Pressure Differential			Fluid Temp.		Seat Seal	Valve Ref.	Housing Ref.	Coil Ref.	Power		Coil Group	Dwg. No.	
	1	(2)	1	(2)	1	(2)	Min	Max (MOPD)	Min	Max					AC W	DC W			
BSP	mm		Kv l/min		KV m³/h		AC bar	DC bar	°C	°C									
1/4"	1.5	1.5	1.4	1.4	0.08	0.08	0	16	16	-10	120	FKM	132K04	4270	481000	8	8	2.1	3510
	1.5	1.5	1.4	1.4	0.08	0.08	0	16	16	-10	100	FKM	132K04	2995	481865	8	9	2.1	3510
	2	2	1.8	1.8	0.11	0.11	0	10	10	-10	120	FKM	132K06	4270	481000	8	8	2.1	3510
	2	2	1.8	1.8	0.11	0.11	0	10	10	-10	100	FKM	132K06	2995	481865	8	9	2.1	3510
	2	3	2.5	4.5	0.15	0.27	0	10	5	-10	75	FKM	132T23	4270	481000	8	8	2.0	3223
	2	3	2.5	4.5	0.15	0.27	0	10	5	-10	75	FKM	132T23	2995	481865	8	9	2.0	3223
	2	3	2.5	4.5	0.15	0.27	0	-	10	-10	75	FKM	132T23	4270	486265	-	14	2.0	3223
	2	3	2.5	4.5	0.15	0.27	0	10	5	-10	75	FKM	132T2301 <sub>1</sub>	4270	481000	8	8	2.0	3223
	2	3	2.5	4.5	0.15	0.27	0	10	5	-10	75	FKM	132T2301 <sub>1</sub>	2995	481865	8	9	2.0	3223
	2	3	2.5	4.5	0.15	0.27	0	-	10	-10	75	FKM	132T2301 <sub>1</sub>	4270	486265	-	14	2.0	3223
	2.5	2.5	2.2	2.2	0.13	0.13	0	7	7	-10	120	FKM	132K03	4270	481000	8	8	2.1	3510
	2.5	2.5	2.2	2.2	0.13	0.13	0	7	7	-10	100	FKM	132K03	2995	481865	8	9	2.1	3510
	3	4	4.5	6	0.27	0.36	0	10	-	-10	75	FKM	132T22	4270	481044	14	-	2.2	3223
	3	4	4.5	6	0.27	0.36	0	7	-	-10	75	FKM	132T22	2995	492425	14	-	2.2	3223

Notes:

1. With manual override



### 3 WAY VALVES



For this page	Port size	Orifice (mm)	Kv (l/min)	MOPD (bar)	Fluid Temp (°C)
From	1/4"	1.5	1.4	5	-10
To	1/4"	3	4.5	16	120

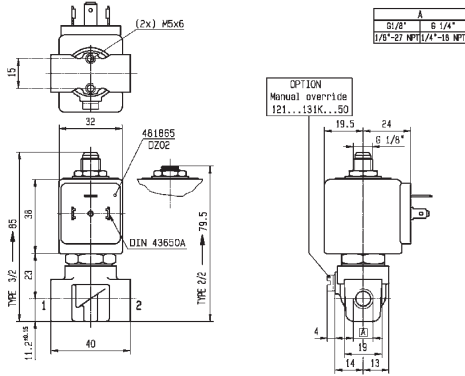

Drawing 3510

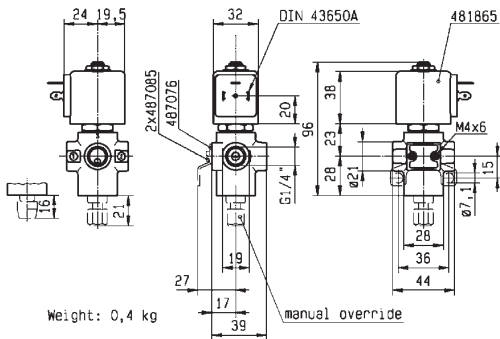

Drawing 3223

### 3 WAY VALVES

# 3/2

## VALVES FOR DRY OR LUBRICATED AIR, NEUTRAL GASES AND LIQUIDS DIRECT OPERATED

### BRASS

### PIPE MOUNTING

### UNIVERSAL

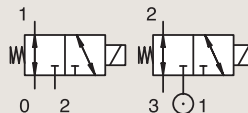

Port size	Orifice Ø		Flow factors		Operating Pressure Differential			Fluid Temp.		Seat Seal	Valve Ref.	Housing Ref.	Coil Ref.	IS	Power		Coil Group	Dwg. No.	
	1	(2)	1	(2)	Min	Max (MOPD)	Min	Max	AC W						DC W				
BSP	mm		Kv		bar	AC bar	DC bar	°C	°C										
1/8"	1.5	1.5	1.5	1.5	0.09	0.09	0	10	10	-10	100	FKM	E133K14	2995	481865	8	9	2.1	3510
	1.5	1.5	1.5	1.5	0.09	0.09	0	10	10	-10	120	FKM	E133K14	4270	481000	8	8	2.1	3510
	2	2	2.5	2.5	0.15	0.15	0	7	7	-10	100	FKM	E133K16	2995	481865	8	9	2.1	3510
	2	2	2.5	-	0.15	-	0	7	7	-10	120	FKM	E133K16	4270	481000	8	8	2.1	3510
	2.5	2.5	3.5	3.5	0.21	0.21	0	4	4	-10	100	FKM	E133K13	2995	481865	8	9	2.1	3510
	2.5	2.5	3.5	3.5	0.21	0.21	0	4	4	-10	120	FKM	E133K13	4270	481000	8	8	2.1	3510
1/4"	0.8	0.8	0.3	0.3	0.02	0.02	0	30	30	-10	100	FKM	E133K05	2995	481865	8	9	2.1	3510
	0.8	0.8	0.3	0.3	0.02	0.02	0	30	30	-10	120	FKM	E133K05	4270	481000	8	8	2.1	3510
	0.8	0.8	0.3	0.3	0.02	0.02	0	30	30	-10	120	FKM	E133K05	4270	486265	14	14	2.0	3510
	1.5	1.5	1.5	1.5	0.09	0.09	0	-	3	-20	75	PUR	133K0497	2995	482740	-	1.6	6.0/8.0	8023
	1.5	1.5	1.5	1.5	0.09	0.09	0	3	3	-20	75	PUR	133K0497	-	495900	2.5	2	6.0/8.0	8023
	1.5	1.5	1.5	1.5	0.09	0.09	0	-	3	-20	75	PUR	133K0497	-	495910	*	0.3-1.2	6.0/8.0	8023
	1.5	1.5	1.5	1.5	0.09	0.09	0	-	3	-20	65	PUR	133K0497	2995	496125	-	1.6	6.0/8.0	8023
	1.5	1.5	1.5	1.5	0.09	0.09	0	10	10	-10	100	FKM	E133K04	2995	481865	8	9	2.0	3510
	1.5	1.5	1.5	1.5	0.09	0.09	0	10	10	-10	120	FKM	E133K04	4270	481000	8	8	2.0	3510
	1.5	1.5	1.5	1.5	0.09	0.09	0	10	10	-10	120	FKM	E133K04	4270	486265	14	14	2.0	3510
	1.5	1.5	1.5	1.5	0.09	0.09	0	10	10	-10	100	FKM	E133K0450	2995	481865	8	9	2.1	3510
	1.5	1.5	1.5	1.5	0.09	0.09	0	10	10	-10	120	FKM	E133K0450	4270	481000	8	8	2.1	3510
	2	2	2.5	2.5	0.15	0.15	0	7	7	-10	75	FKM	133T23	2995	481865	8	9	2.1	3223
	2	2	2.5	2.5	0.15	0.15	0	7	7	-10	75	FKM	133T23	4270	481000	8	8	2.1	3223
	2	2	2.5	2.5	0.15	0.15	0	7	7	-10	75	FKM	133T2301	2995	481865	8	9	2.1	3223
	2	2	2.5	2.5	0.15	0.15	0	7	7	-10	75	FKM	133T2301	4270	481000	8	8	2.1	3223
	2	2	2.5	2.5	0.15	0.15	0	7	7	-10	100	FKM	E133K06	2995	481865	8	9	2.0/3.0	3510
	2	2	2.5	2.5	0.15	0.15	0	7	7	-10	120	FKM	E133K06	4270	481000	8	8	2.0/3.0	3510
2	2	2.5	2.5	0.15	0.15	0	7	7	-10	120	FKM	E133K06	4270	486265	14	14	2.0/3.0	3510	
2	2	2.5	2.5	0.15	0.15	0	7	7	-10	100	FKM	E133K0650	2995	481865	8	9	2.1	3510	
2	2	2.5	2.5	0.15	0.15	0	7	7	-10	120	FKM	E133K0650	4270	481000	8	8	2.1	3510	
2.5	2.5	3.5	3.5	0.21	0.21	0	4	4	-10	100	FKM	E133K03	2995	481865	8	9	2.0	3510	
2.5	2.5	3.5	3.5	0.21	0.21	0	4	4	-10	120	FKM	E133K03	4270	481000	8	8	2.0	3510	
2.5	2.5	3.5	3.5	0.21	0.21	0	4	4	-10	120	FKM	E133K03	4270	486265	14	14	2.0	3510	
2.5	2.5	3.5	3.5	0.21	0.21	0	4	4	-10	100	FKM	E133K0350	2995	481865	8	9	2.1	3510	
2.5	2.5	3.5	3.5	0.21	0.21	0	4	4	-10	120	FKM	E133K0350	4270	481000	8	8	2.1	3510	
3	3	4.5	4.5	0.27	0.27	0	2	2	-10	75	FKM	133T21	2995	481865	8	9	2.1	3223	
3	3	4.5	4.5	0.27	0.27	0	2	2	-10	75	FKM	133T21	4270	481000	8	8	2.1	3223	

Notes:

1. With manual override



### 3 WAY VALVES



For this page	Port size	Orifice (mm)	Kv (l/min)	MOPD (bar)	Fluid Temp (°C)
From	1/8"	0.8	0.3	2	-20
To	1/4"	3	4.5	30	120

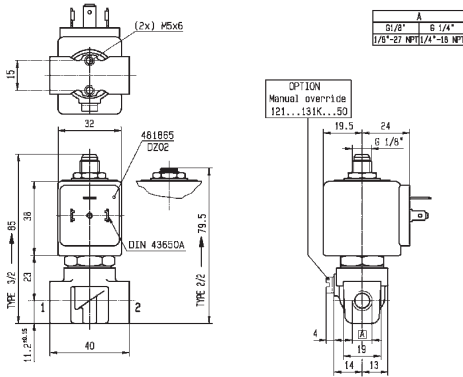

Drawing 3510

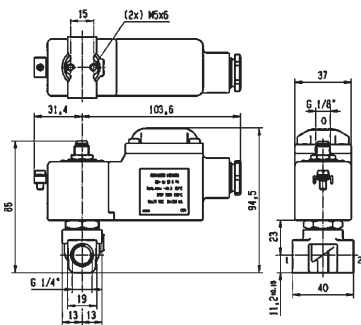

Drawing 8023

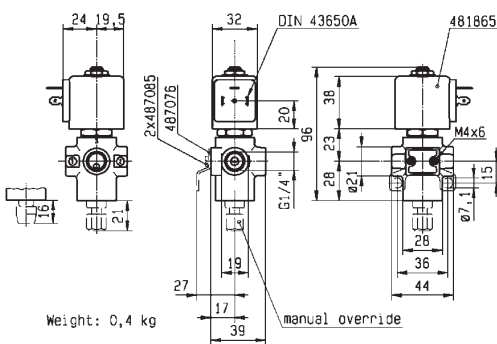

Drawing 3223



### 3 WAY VALVES

# 3/2

## VALVES FOR DRY OR LUBRICATED AIR, NEUTRAL GASES AND LIQUIDS DIRECT OPERATED

### BRASS

#### PIPE MOUNTING

#### UNIVERSAL

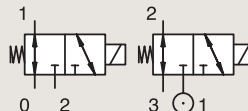

Port size	Orifice Ø		Flow factors		Operating Pressure Differential			Fluid Temp.		Seat Seal	Valve Ref.	Housing Ref.	Coil Ref.	IS	Power		Coil Group	Dwg. No.	
	1	(2)	1	(2)	1	(2)	Min	Max (MOPD)	Min						Max	AC W			DC W
BSP	mm		Kv	l/min	KV	m³/h	bar	AC bar	DC bar	°C	°C								
1/4"	3	3	4.5	4.5	0.27	0.27	0	2	2	-10	75	FKM	133T2101 <sub>1</sub>	2995	481865	8	9	2.1	3223
	3	3	4.5	4.5	0.27	0.27	0	2	2	-10	75	FKM	133T2101 <sub>1</sub>	4270	481000	8	8	2.1	3223

Notes:

1. With manual override

### BRASS

#### PIPE MOUNTING

#### CONTROL BY ELECTRIC IMPULSE

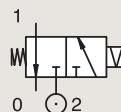

Port size	Orifice Ø		Flow factors		Operating Pressure Differential			Fluid Temp.		Seat Seal	Valve Ref.	Housing Ref.	Coil Ref.	Power		Coil Group	Dwg. No.		
	1	(2)	1	(2)	1	(2)	Min	Max (MOPD)	Min					Max	AC W			DC W	
BSP	mm		Kv	l/min	KV	m³/h	bar	AC bar	DC bar	°C	°C								
1/4"	1.5	1.5	1.5	1.5	0.09	0.09	0	-	16	-10	100	FKM	135K04	4269	485400	-	13	4.0	8104

3 WAY VALVES



For this page	Port size	Orifice (mm)	Kv (l/min)	MOPD (bar)	Fluid Temp (°C)
From	1/4"	1.5	1.5	2	-10
To	1/4"	3	4.5	16	100

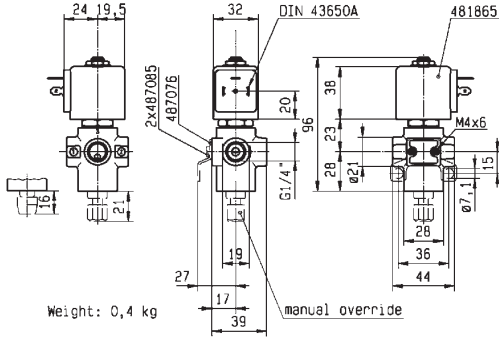

Drawing 3223

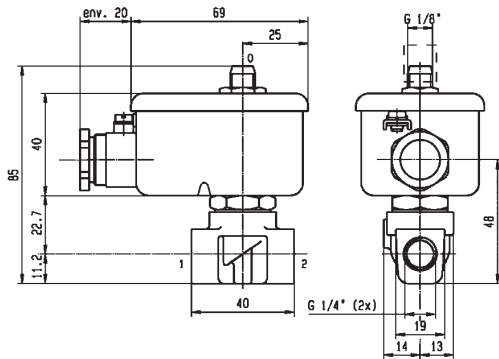

Drawing 8104

### 3 WAY VALVES

# 3/2

## VALVES FOR DRY OR LUBRICATED AIR, NEUTRAL GASES AND LIQUIDS DIRECT OPERATED

BRASS

SUB-BASE MOUNTING

NORMALLY CLOSED

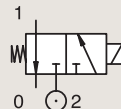

Port size	Orifice Ø		Flow factors				Operating Pressure Differential			Fluid Temp.		Seat Seal	Valve Ref.	Housing Ref.	Coil Ref.	IS	Power		Coil Group	Dwg. No.
	1	(2)	1	(2)	1	(2)	Min	Max (MOPD)	Min	Max	AC W						DC W			
	mm		Kv l/min		KV m³/h		bar	AC bar	DC bar	°C								°C		
SB	1.2	1.5	0.7	0.9	0.04	0.05	0	10	10	-10	75	FKM	131M75	8993	488980		2	2.5	1.1	3383
	1.2	1.5	0.7	0.9	0.04	0.05	0	10	10	-10	75	FKM	131M7550 <sub>1</sub>	8993	488980		2	2.5	1.1	3383
	1.5	1.5	0.9	0.9	0.05	0.05	0	7	7	-10	75	FKM	131M74	8993	488980		2	2.5	1.1	3383
	1.5	1.5	0.9	0.9	0.05	0.05	0	7	7	-10	75	FKM	131M7450 <sub>1</sub>	8993	488980		2	2.5	1.1	3383
SB	1	1	0.6	0.6	0.04	0.036	0	-	10	-10	55	FKM	131F4490	2995	48358001	*	-	0.5-3	7.0	7057
	1	1	0.6	0.6	0.04	0.036	0	-	10	-10	75	FKM	131F4490	-	495910	*	-	0.3-1.2	7.0	7057
	1.5	2	1.5	2.2	0.09	0.13	0	-	16	-10	100	FKM	131F4410	2995	481865		-	9	2.1	3509
	1.5	1.5	1.5	1.5	0.09	0.09	0	-	7	-20	75	PUR	131F4497	2995	482740		-	1.6	6.0/8.0	8022
	1.5	1.5	1.5	1.5	0.09	0.09	0	7	7	-20	75	PUR	131F4497	-	495900		2.5	2	6.0/8.0	8022
	1.5	1.5	1.5	1.5	0.09	0.09	0	-	7	-20	75	PUR	131F4497	-	495910	*	-	0.3-1.2	6.0/8.0	8022
1.5	1.5	1.5	1.5	0.09	0.09	0	-	7	-20	65	PUR	131F4497	2995	496125		-	1.6	6.0/8.0	8022	

Notes:

1. With manual override

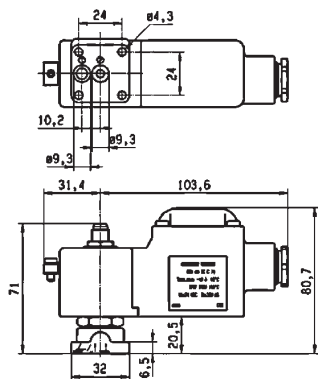

Drawing 8022



### 3 WAY VALVES



For this page	Port size	Orifice (mm)	Kv (l/min)	MOPD (bar)	Fluid Temp (°C)
From	SB	1	0.6	7	-20
To	SB	1.5	1.5	16	100

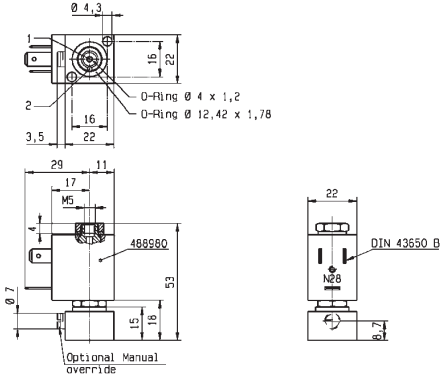

Drawing 3383

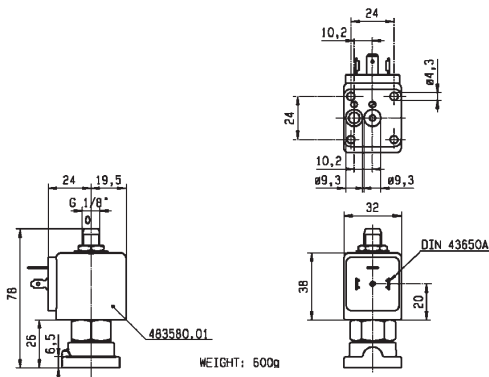

Drawing 7057

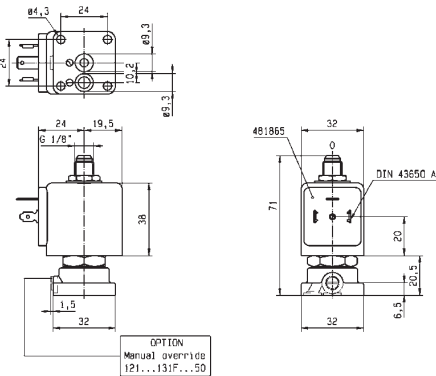

Drawing 3509



### 3 WAY VALVES

# 3/2

## VALVES FOR DRY OR LUBRICATED AIR, NEUTRAL GASES AND LIQUIDS DIRECT OPERATED

### BRASS

#### SUB-BASE MOUNTING

#### NORMALLY CLOSED

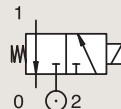

Port size	Orifice Ø		Flow factors		Operating Pressure Differential			Fluid Temp.		Seat Seal	Valve Ref.	Housing Ref.	Coil Ref.	IS	Power		Coil Group	Dwg. No.	
	1	(2)	1	(2)	Min	Max (MOPD)	Min	Max	AC W						DC W				
	mm		Kv l/min	KV m³/h	bar	AC bar	DC bar	°C								°C			
SB	1.5	1.5	1.5	1.5	0.09	0.09	0	15	15	-10	100	FKM	E131F44	2995	481865	8	9	2.1	3509
	1.5	1.5	1.5	1.5	0.09	0.09	0	15	15	-10	120	FKM	E131F44	4270	481000	8	8	2.1	3509
	1.5	1.5	1.5	1.5	0.09	0.09	0	15	15	-10	100	FKM	E131F4450 <sub>1</sub>	2995	481865	8	9	2.1	3509
	1.5	1.5	1.5	1.5	0.09	0.09	0	15	15	-10	100	FKM	E131F4450 <sub>1</sub>	4270	481000	8	8	2.1	3509
	2	2.5	2.5	3.5	0.15	0.21	0	10	10	-10	100	FKM	131F46	2995	481865	8	9	2.1	3509
	2	2.5	2.5	3.5	0.15	0.21	0	10	10	-10	120	FKM	131F46	4270	481000	8	8	2.1	3509
	2	2.5	2.5	3.5	0.15	0.21	0	10	10	-10	100	FKM	131F4650 <sub>1</sub>	2995	481865	8	9	2.1	3509
	2	2.5	2.5	3.5	0.15	0.21	0	10	10	-10	120	FKM	131F4650 <sub>1</sub>	4270	481000	8	8	2.1	3509
	2.5	2.5	3.5	3.5	0.21	0.21	0	7	7	-10	100	FKM	E131F43	2995	481865	8	9	2.1	3509
	2.5	2.5	3.5	3.5	0.21	0.21	0	7	7	-10	120	FKM	E131F43	4270	481000	8	8	2.1	3509
	2.5	2.5	3.5	3.5	0.21	0.21	0	7	7	-10	100	FKM	E131F4350 <sub>1</sub>	2995	481865	8	9	2.0	3509
	2.5	2.5	3.5	3.5	0.21	0.21	0	7	7	-10	120	FKM	E131F4350 <sub>1</sub>	4270	481000	8	8	2.0	3509
2.5	2.5	3.5	3.5	0.21	0.21	0	7	7	-10	100	FKM	E131F4350 <sub>1</sub>	4270	486265	14	14	2.0	3509	

Notes:

1. With manual override

### BRASS

#### SUB-BASE MOUNTING

#### NORMALLY OPEN

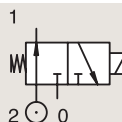

Port size	Orifice Ø		Flow factors		Operating Pressure Differential			Fluid Temp.		Seat Seal	Valve Ref.	Housing Ref.	Coil Ref.	Power	Coil Group	Dwg. No.			
	1	(2)	1	(2)	Min	Max (MOPD)	Min	Max	AC W								DC W		
	mm		Kv l/min	KV m³/h	bar	AC bar	DC bar	°C										°C	
SB	1.5	1.5	1.4	1.4	0.08	0.08	0	15	15	-10	75	FKM	132F44	4270	481000	8	8	2.1	3509
	1.5	1.5	1.4	1.4	0.08	0.08	0	15	15	-10	75	FKM	132F44	2995	481865	8	9	2.1	3509
	2	2	1.8	1.8	0.11	0.11	0	10	10	-10	120	FKM	132F46	4270	481000	8	8	2.1	3509
	2	2	1.8	1.8	0.11	0.11	0	10	10	-10	100	FKM	132F46	2995	481865	8	9	2.1	3509
	2.5	2.5	2.2	2.2	0.13	0.13	0	7	7	-10	75	FKM	132F43	4270	481000	8	8	2.0	3509
	2.5	2.5	2.2	2.2	0.13	0.13	0	7	7	-10	75	FKM	132F43	2995	481865	8	9	2.0	3509
	2.5	2.5	2.2	2.2	0.13	0.13	0	7	7	-10	75	FKM	132F43	4270	486265	14	14	2.0	3509



### 3 WAY VALVES



For this page	Port size	Orifice (mm)	Kv (l/min)	MOPD (bar)	Fluid Temp (°C)
From	SB	1.5	1.4	7	-10
To	SB	2.5	3.5	15	120

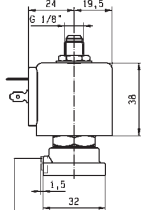
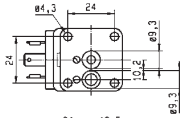

OPTION  
Manual override  
121...131F...50

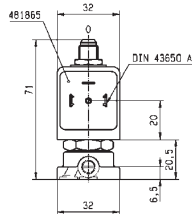

Drawing 3509

### 3 WAY VALVES

# 3/2

## VALVES FOR DRY OR LUBRICATED AIR, NEUTRAL GASES AND LIQUIDS DIRECT OPERATED

### BRASS

### SUB-BASE MOUNTING

### UNIVERSAL

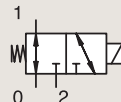

Port size	Orifice Ø		Flow factors			Operating Pressure Differential			Fluid Temp.		Seat Seal	Valve Ref.	Housing Ref.	Coil Ref.	Power		Coil Group	Dwg. No.	
	1	(2)	1	(2)	1	(2)	Min	Max (MOPD)	Min	Max					AC W	DC W			
	mm		Kv l/min		KV m³/h		bar	AC bar	DC bar	°C	°C								
SB	1.5	1.5	1.5	1.5	0.09	0.09	0	10	10	-10	100	FKM	E133F4450	4270	481000	8	8	2.1	3509
	1.5	1.5	1.5	1.5	0.09	0.09	0	10	10	-10	120	FKM	E133F4450	2995	481865	8	9	2.1	3509
	1.5	1.5	1.5	1.5	0.09	0.09	0	10	10	-10	120	FKM	E133F44	4270	481000	8	8	2.1	3509
	1.5	1.5	1.5	1.5	0.09	0.09	0	10	10	-10	100	FKM	E133F44	2995	481865	8	9	2.1	3509
	2	2	2.5	2.5	0.15	0.15	0	7	7	-10	120	FKM	133F46	4270	481000	8	8	2.1	3509
	2	2	2.5	2.5	0.15	0.15	0	7	7	-10	100	FKM	133F46	2995	481865	8	9	2.1	3509
	2.5	2.5	3.5	3.5	0.21	0.21	0	4	4	-10	120	FKM	E133F43	4270	481000	8	8	2.1	3509
	2.5	2.5	3.5	3.5	0.21	0.21	0	4	4	-10	100	FKM	E133F43	2995	481865	8	9	2.1	3509

Notes:  
1. With manual override



### 3 WAY VALVES



For this page	Port size	Orifice (mm)	Kv (l/min)	MOPD (bar)	Fluid Temp (°C)
From	SB	1.5	1.5	4	-10
To	SB	2.5	3.5	10	120

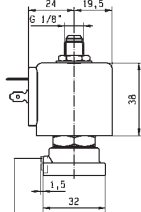
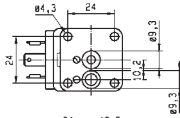

OPTION  
Manual override  
121...131F...50

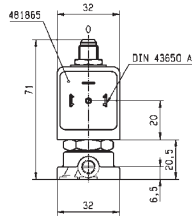

Drawing 3509

### 3 WAY VALVES

# 3/2

## VALVES FOR DRY OR LUBRICATED AIR, NEUTRAL GASES AND LIQUIDS DIRECT OPERATED

### ANODIZED ALUMINIUM

#### BANJO

#### NORMALLY CLOSED

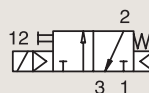

Port size	Orifice Ø	Flow factor	Operating Pressure Differential			Fluid Temp.		Seat Seal	Valve Ref.	Housing Ref.	Coil Ref.	Power		Coil Group	Dwg. No.
			Min	Max (MOPD)	DC bar	Min	Max					AC W	DC W		
BSP	1	Qn l/min	bar	AC bar	DC bar	°C	°C								
	1.2	50	0	10	10	-10	50	NBR	131B14 <sub>12</sub>	-	496131	3	3	1.2	8227
1/8"	1.2	50	0	10	10	-10	50	NBR	131B14 <sub>12</sub>	-	496482	3	3	1.2	8227
	1.2	50	0	10	10	-10	50	NBR	131B14 <sub>12</sub>	-	496637	3	3	1.2	8227

**Notes:**

- 1.Valve only compatible with air and neutral gases
- 2.With manual override

### ANODIZED ALUMINIUM

#### BANJO

#### NORMALLY CLOSED

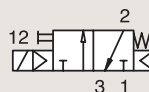

Port size	Orifice Ø	Flow factor	Operating Pressure Differential			Fluid Temp.		Seat Seal	Valve Ref.	Housing Ref.	Coil Ref.	Power		Coil Group	Dwg. No.
			Min	Max (MOPD)	DC bar	Min	Max					AC W	DC W		
BSP	1	Qn l/min	bar	AC bar	DC bar	°C	°C								
	1.2	50	0	10	10	-10	50	NBR	131B04 <sub>12</sub>	-	496131	3	3	1.2	8226
1/4"	1.2	50	0	10	10	-10	50	NBR	131B04 <sub>12</sub>	-	496482	3	3	1.2	8226
	1.2	50	0	10	10	-10	50	NBR	131B04 <sub>12</sub>	-	496637	3	3	1.2	8226

**Notes:**

- 1.Valve only compatible with air and neutral gases
- 2.With manual override



### 3 WAY VALVES



For this page	Port size	Orifice (mm)	Qn (l/min)	MOPD (bar)	Fluid Temp (°C)
From	1/8"	1.2	50	10	-10
To	1/4"	1.2	50	10	50

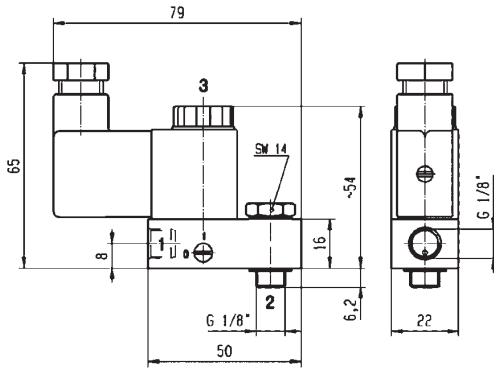

Drawing 8227

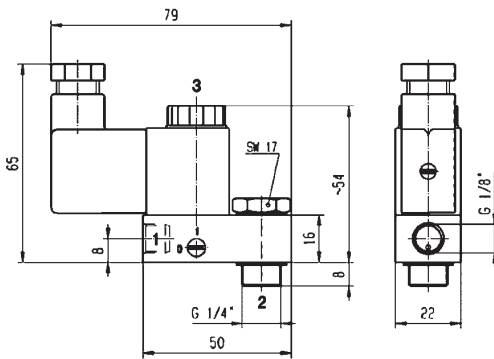

Drawing 8226

### 3 WAY VALVES

# 3/2

VALVES FOR DRY OR LUBRICATED AIR, NEUTRAL GASES AND LIQUIDS  
DIRECT OPERATED

316L STAINLESS ST.  
SUB-BASE MOUNTING

**NORMALLY CLOSED**

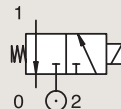

Port size	Orifice Ø		Flow factors				Operating Pressure Differential			Fluid Temp.		Seat Seal	Valve Ref.	Housing Ref.	Coil Ref.	Power		Coil Group	Dwg. No.
	1	(2)	1	(2)	1	(2)	Min	Max (MOPD)	Min	Max	AC W					DC W			
BSP	mm		Kv l/min		KV m³/h		bar	AC bar	DC bar	°C	°C								
SB	1.5	1.5	1.5	2.2	0.09	0.13	0	15	15	-10	100	FKM	131F5406	2995	481865	8	9	2.1	3509

### 3 WAY VALVES



For this page	Port size	Orifice (mm)	Kv (l/min)	MOPD (bar)	Fluid Temp (°C)
From	SB	1.5	1.5	15	-10
To	SB	1.5	1.5	15	100

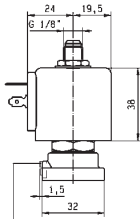
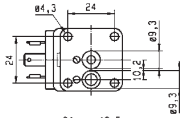

OPTION  
Manual override  
121...131F...50

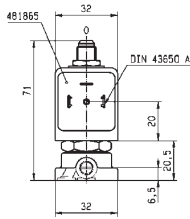

Drawing 3509

### 3 WAY VALVES

# 3/2

VALVES FOR DRY OR LUBRICATED AIR, NEUTRAL GASES AND LIQUIDS  
DIRECT OPERATED

POM

SUB-BASE MOUNTING

NORMALLY CLOSED

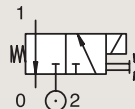

Port size	Orifice Ø		Flow factors		Operating Pressure Differential			Fluid Temp.		Seat Seal	Valve Ref.	Housing Ref.	Coil Ref.	Power		Coil Group	Dwg. No.		
	1	(2)	1	(2)	Min	Max (MOPD)	Min	Max	AC W					DC W					
	mm		Kv l/min	KV m³/h	bar	AC bar	DC bar	°C	°C										
SB	2	2	2	2	0.12	0.12	0	10	10	-10	50	FKM	E131F26 <sub>12</sub>	2995	481865	8	9	2.1/3.0	3601
	2	2	2	2	0.12	0.12	0	10	10	-10	50	FKM	E131F26 <sub>2</sub>	2995	482730	6	7	2.1/3.0	3601

**Notes:**

1.20% Switch-on - max. 2 min

2.With manual override

### 3 WAY VALVES



For this page	Port size	Orifice (mm)	Kv (l/min)	MOPD (bar)	Fluid Temp (°C)
From	SB	2	2	10	-10
To	SB	2	2	10	50

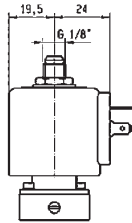
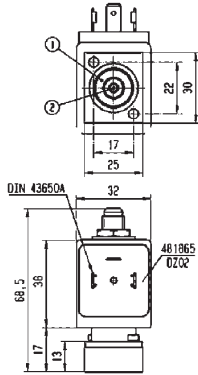

Drawing 3601

### 3 WAY VALVES

# 3/2

VALVES FOR DRY OR LUBRICATED AIR, NEUTRAL GASES AND LIQUIDS  
DIRECT OPERATED

STAINLESS ST.  
SUB-BASE MOUNTING

**NORMALLY CLOSED**

Port size	Orifice Ø		Flow factors				Operating Pressure Differential			Fluid Temp.		Seat Seal	Valve Ref.	Coil Ref.	Power		Coil Group	Compatible Adapter Kit
	1	(2)	1	(2)	1	(2)	Min	Max (MOPD)	Min	Max	AC W				DC W			
	mm		Kv l/min	KV m <sup>3</sup> /h	bar	AC bar	DC bar	°C	°C									
SB	1.5	2.5	1.4	2.9	0.08	0.17	0	14	14	-10	140	Ruby	3019F1GRG7	481865	9	8	2.0	XGSPG1-XGSPG2
	1.5	2.5	1.4	2.9	0.08	0.17	0	14	14	-10	140	FKM FDA	3019F1GVG7	481865	9	8	2.0	XGSPG1-XGSPG2
	2.0	2.5	2.1	2.9	0.13	0.17	0	10	10	-10	140	Ruby	3019F1JRG7	481865	9	8	2.0	XGSPG1-XGSPG2
	2.0	2.5	2.1	2.9	0.13	0.17	0	10	10	-10	140	FKM FDA	3019F1JVG7	481865	9	8	2.0	XGSPG1-XGSPG2
	2.5	2.5	2.9	2.9	0.17	0.17	0	6.5	6.5	-10	140	Ruby	3019F1LRG7	481865	9	8	2.0	XGSPG1-XGSPG2
	2.5	2.5	2.9	2.9	0.17	0.17	0	6.5	6.5	-10	140	FKM FDA	3019F1LVG7	481865	9	8	2.0	XGSPG1-XGSPG2
	3.0	2.5	3.3	2.9	0.20	0.17	0	4	4	-10	140	Ruby	3019F1NRG7	481865	9	8	2.0	XGSPG1-XGSPG2
	3.0	2.5	3.3	2.9	0.20	0.17	0	4	4	-10	140	FKM FDA	3019F1NVG7	481865	9	8	2.0	XGSPG1-XGSPG2
	4.0	2.5	6.5	2.9	0.39	0.17	0	3	3	-10	140	FKM FDA	3019F1QVG7	481865	9	8	2.0	XGSPG3
	4.0	2.5	6.5	2.9	0.39	0.17	0	3	3	-10	140	EPDM	3019F1QEG7	481865	9	8	2.0	XGSPG3
	5.0	2.5	7.2	0.43	0.43	0.17	0	2	2	-10	140	FKM FDA	3019F1SVG7	481865	9	8	2.0	XGSPG3
	5.0	2.5	7.2	0.43	0.43	0.17	0	2	2	-10	140	EPDM	3019F1SEG7	481865	9	8	2.0	XGSPG3

### 3 WAY VALVES



For this page	Port size	Orifice (mm)	Kv (l/min)	MOPD (bar)	Fluid Temp (°C)
From	SB	2	2	10	-10
To	SB	2	2	10	50

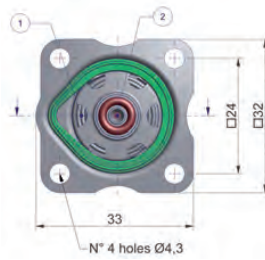
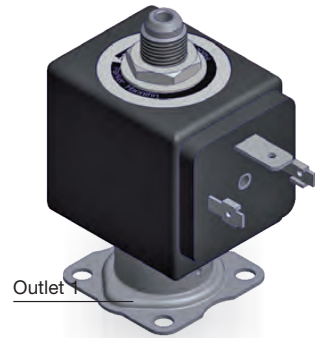
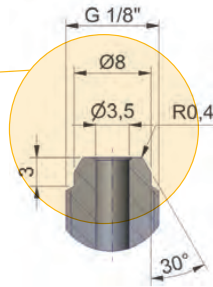
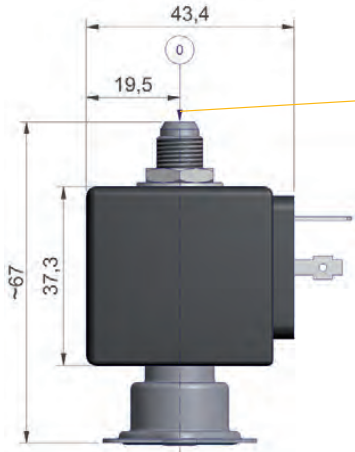

All dimensions are in mm

### 3 WAY VALVES

# 3/2

## VALVES FOR DRY OR LUBRICATED AIR, NEUTRAL GASES AND LIQUIDS DIRECT OPERATED

STAINLESS ST.  
SUB-BASE MOUNTING

UNIVERSAL



Port size	Orifice Ø		Flow factors				Operating Pressure Differential			Fluid Temp.		Seat Seal	Valve Ref.	Coil Ref.	Power		Coil Group	Compatible Adapter Kit
	1	(2)	1	(2)	1	(2)	Min	Max (MOPD)	Min	Max	AC W				DC W			
	mm		Kv l/min		KV m <sup>3</sup> /h	bar	AC bar	DC bar	°C	°C								
SB	1.5	1.5	1.4	1.3	0.08	0.8	0	9.5	9.5	-10	140	FKM FDA	3039F1GVG7	481865	9	8	2.0	XGSPG1 - XGSPG2
	1.5	1.5	1.4	1.3	0.08	0.8	0	9.5	9.5	-10	140	EPDM	3039F1GEG7	481865	9	8	2.0	XGSPG1 - XGSPG2
	2.0	2.0	2.1	2.0	0.13	0.12	0	3.5	3.5	-10	140	FKM FDA	3039F1JVG7	481865	9	8	2.0	XGSPG1 - XGSPG2
	2.0	2.0	2.1	2.0	0.13	0.12	0	3.5	3.5	-10	140	EPDM	3039F1JEG7	481865	9	8	2.0	XGSPG1 - XGSPG2
	2.5	2.5	2.8	2.8	0.17	0.17	0	2	2	-10	140	FKM FDA	3039F1LVG7	481865	9	8	2.0	XGSPG1 - XGSPG2
	2.5	2.5	2.8	2.8	0.17	0.168	0	2	2	-10	140	EPDM	3039F1LEG7	481865	9	8	2.0	XGSPG1 - XGSPG2
	3.0	2.5	3.3	2.8	0.2	0.17	0	2	2	-10	140	FKM FDA	3039F1NVG7	481865	9	8	2.0	XGSPG1 - XGSPG2
	3.0	2.5	3.3	2.8	0.2	0.168	0	2	2	-10	140	EPDM	3039F1NEG7	481865	9	8	2.0	XGSPG1 - XGSPG2

### 3 WAY VALVES



For this page	Port size	Orifice (mm)	Kv (l/min)	MOPD (bar)	Fluid Temp (°C)
From	SB	2	2	10	-10
To	SB	2	2	10	50

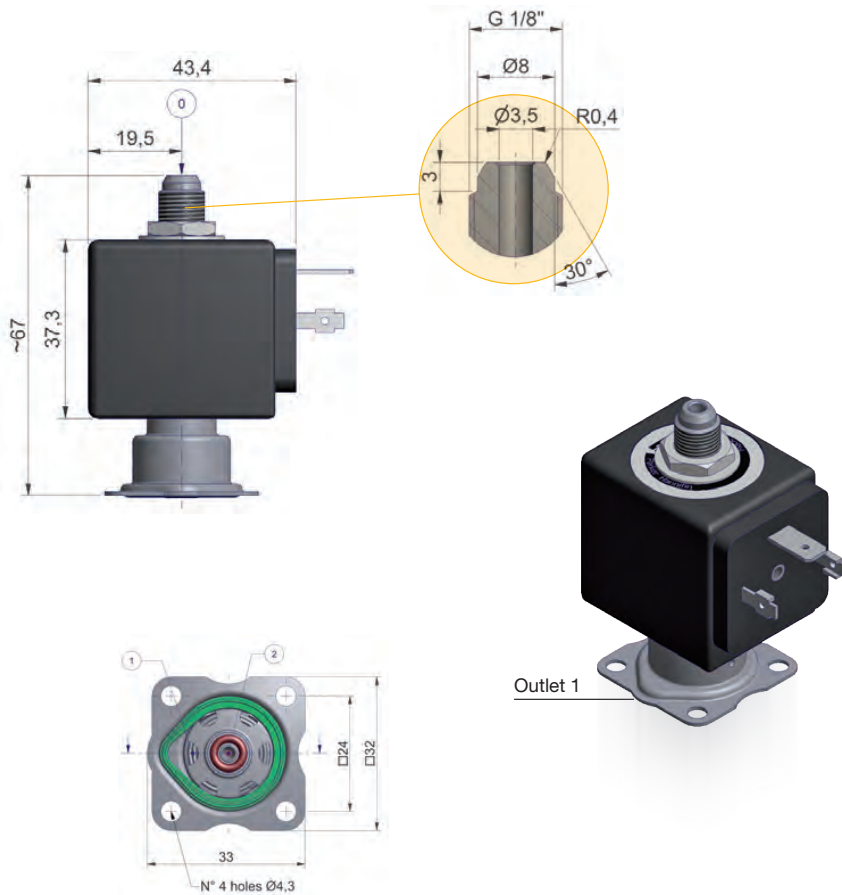

All dimensions are in mm



### 3 WAY VALVES

# 3/2

## VALVES FOR DRY OR LUBRICATED AIR, NEUTRAL GASES AND LIQUIDS PILOT OPERATED

### ANODIZED ALUMINIUM

### PIPE MOUNTING

### NORMALLY CLOSED

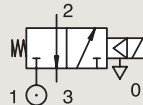

Port size	Orifice Ø		Flow factors		Operating Pressure Differential			Fluid Temp.		Seat Seal	Valve Ref.	Housing Ref.	Coil Ref.	IS	Power		Coil Group	Dwg. No.		
	1	(2)	1	(2)	Min	Max (MOPD)	Min	Max	AC W						DC W					
BSP	mm		Kv l/min	Q l/min	bar	AC bar	DC bar	°C	°C											
1/4"	6.5	6.5	10	-	645	-	1	-	10	-10	55	NBR	331B7490 <sub>1</sub>	2995	48358001	*	-	0.5-3	7.0/8.0	8270
	6.5	6.5	10	-	645	-	1	-	10	-10	75	NBR	331B7490 <sub>1</sub>	-	495910	*	-	0.3-1.2	7.0/8.0	8270
	6.5	6.5	10	-	750	-	1	10	10	-10	75	NBR	E331B74 <sub>13</sub>	2995	481865		8	9	2.1	3240
	6.5	6.5	10	-	750	-	1	10	10	-10	75	NBR	E331B74 <sub>13</sub>	4270	485100		8	8	2.1	3240
	8	8	20	20	1100	1100	1	15	15	-10	75	NBR	E331B01 <sub>2</sub>	4270	481000		8	8	2.1	3234
	8	8	20	20	1100	1100	1	15	15	-10	75	NBR	E331B01 <sub>2</sub>	2995	481865		8	9	2.1	3234
	8	8	20	20	1100	1100	1	15	15	-10	65	NBR	E331B01 <sub>2</sub>	-	483371		8	8	2.1	3234

#### Notes:

1. Valve only compatible with air and neutral gases
2. Valve only compatible with hydraulic oil and air/neutral gases
3. With manual override

### 3 WAY VALVES



For this page	Port size	Orifice (mm)	Kv (l/min)	MOPD (bar)	Fluid Temp (°C)
From	1/4"	6.5	10	10	-10
To	1/4"	8	20	15	75

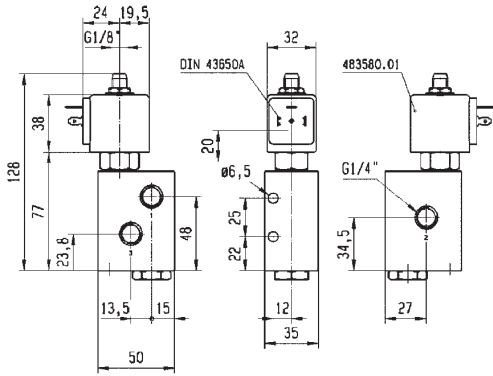

Drawing 8270

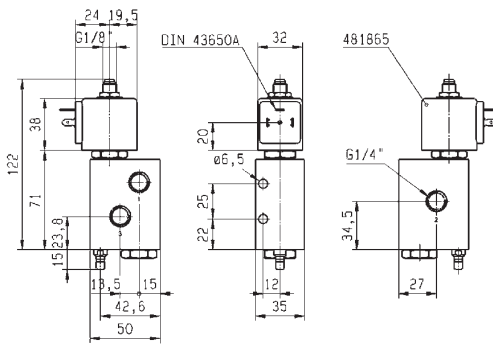

Weight: 0,51 kg

Drawing 3240

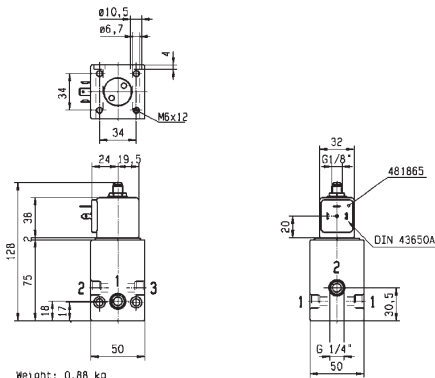

Weight: 0,88 kg

Drawing 3234



### 3 WAY VALVES

# 3/2

## VALVES FOR DRY OR LUBRICATED AIR, NEUTRAL GASES AND LIQUIDS PILOT OPERATED

### ANODIZED ALUMINIUM

#### PIPE MOUNTING

#### NORMALLY CLOSED

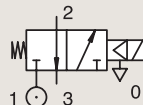

Port size	Orifice Ø		Flow factors		Operating Pressure Differential			Fluid Temp.		Seat Seal	Valve Ref.	Housing Ref.	Coil Ref.	Power		Coil Group	Dwg. No.		
	1	(2)	1	(2)	1	(2)	Min	Max (MOPD)	Min					Max	AC W			DC W	
BSP	mm		Kv	l/min	Q	l/min	bar	AC bar	DC bar	°C	°C								
1/2"	14	14	-	-	2500	2500	1	15	-	-10	75	NBR	E331B21 <sub>1</sub>	2995	482722	-	-	2.1	3238
	14	14	-	-	2500	2500	1	15	15	-10	65	NBR	E331B21 <sub>1</sub>	-	483371	8	8	2.1	3238

**Notes:**

1. Valve only compatible with air and neutral gases
2. Valve only compatible with hydraulic oil and air/neutral gases
3. With manual override

### ANODIZED ALUMINIUM

#### PIPE MOUNTING

#### NORMALLY OPEN

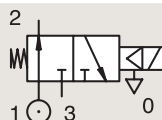

Port size	Orifice Ø		Flow factors		Operating Pressure Differential			Fluid Temp.		Seat Seal	Valve Ref.	Housing Ref.	Coil Ref.	Power		Coil Group	Dwg. No.		
	1	(2)	1	(2)	1	(2)	Min	Max (MOPD)	Min					Max	AC W			DC W	
BSP	mm		Kv	l/min	Q	l/min	bar	AC bar	DC bar	°C	°C								
1/4"	8	8	10	10	750	750	1	40	40	-10	75	NBR	332B02 <sub>23</sub>	2995	481865	8	9	2.1	8114
	8	8	10	10	750	750	1	40	40	-10	75	NBR	332B02 <sub>23</sub>	4270	481000	8	8	2.1	8114
	8	8	20	20	1100	1100	1	15	15	-10	75	NBR	E332B01 <sub>3</sub>	2995	481865	8	9	2.1	3234
	8	8	20	20	1100	1100	1	15	15	-10	75	NBR	E332B01 <sub>3</sub>	4270	481000	8	8	2.1	3234
	8	8	20	20	1100	1100	1	15	15	-10	65	NBR	E332B01 <sub>3</sub>	-	483371	8	8	2.1	3234

**Notes:**

1. Valve only compatible with air and neutral gases
2. Pilot seat discs in Kel-F (PCTFE); valve with pilot return pipe
3. Valve only compatible with hydraulic oil and air/neutral gases



### 3 WAY VALVES



For this page	Port size	Orifice (mm)	Kv (l/min)	MOPD (bar)	Fluid Temp (°C)
From	1/4"	8	10	15	-10
To	1/4"	14	20	40	75

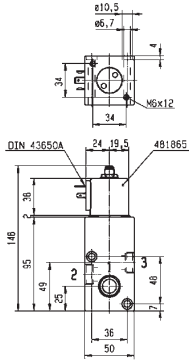

Weight: 0,96 kg



Drawing 3238

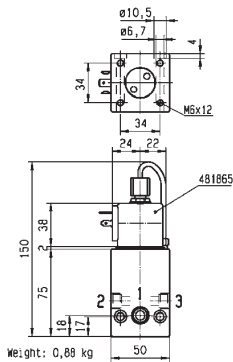

Weight: 0,88 kg

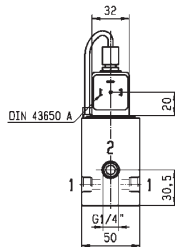

Drawing 8114

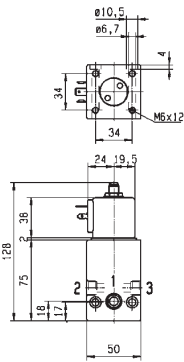

Weight: 0,88 kg

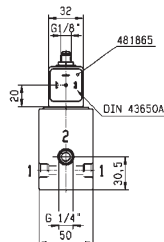

Drawing 3234



### 3 WAY VALVES

# 3/2

## VALVES FOR DRY OR LUBRICATED AIR, NEUTRAL GASES AND LIQUIDS PILOT OPERATED

### ANODIZED ALUMINIUM PIPE MOUNTING

#### NORMALLY OPEN

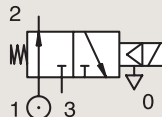

Port size	Orifice Ø		Flow factors		Operating Pressure Differential			Fluid Temp.		Seat Seal	Valve Ref.	Housing Ref.	Coil Ref.	Power		Coil Group	Dwg. No.		
	1	(2)	1	(2)	Min	Max (MOPD)		Min	Max										
						AC bar	DC bar							°C	°C				
BSP	mm		Kv	Q	bar			°C	°C				AC W	DC W					
1/2"	14	14	37.5	-	2500	2500	1	15	15	-10	75	NBR	E332B21 <sub>1</sub>	2995	481865	8	9	2.1	3238
	14	14	37.5	-	2500	2500	1	15	15	-10	75	NBR	E332B21 <sub>1</sub>	4270	481000	8	8	2.1	3238

**Notes:**

- 1. Valve only compatible with air and neutral gases
- 2. With manual override

### ANODIZED ALUMINIUM SUB-BASE MOUNTING

#### NORMALLY CLOSED

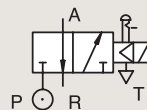

Port size	Orifice Ø	Flow factor	Operating Pressure Differential			Fluid Temp.		Seat Seal	Valve Ref.	Housing Ref.	Coil Ref.	Power		Coil Group	Dwg. No.
			Min	Max (MOPD)		Min	Max								
				AC bar	DC bar							°C	°C		
SB	mm	Qn	bar			°C	°C					AC W	DC W		
SB	15	5000	0.5	10	10	-10	75	NBR	E331L21 <sub>12</sub>	2995	481865	8	9	2.1/3.0	3130
	15	5000	0.5	10	10	-10	65	NBR	E331L21 <sub>12</sub>	-	483371	8	8	2.1/3.0	3130

**Notes:**

- 1. Valve only compatible with air and neutral gases
- 2. With manual override

### 3 WAY VALVES



For this page	Port size	Orifice (mm)	Qn (l/min)	MOPD (bar)	Fluid Temp (°C)
From	1/2"	14	-	10	-10
To	1/2"	15	5000	15	75

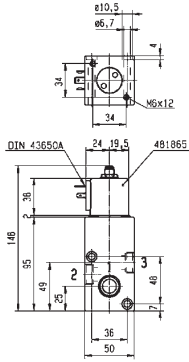

Weight: 0.98 kg



Drawing 3238

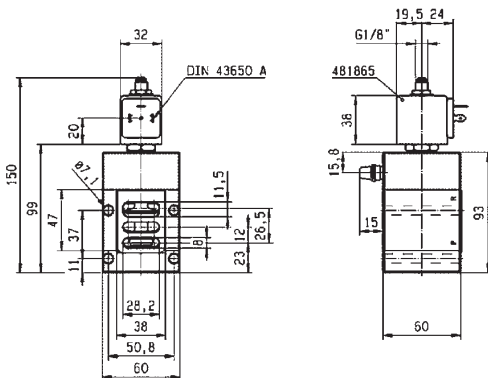

Drawing 3130



## 3 WAY VALVES



VALVES FOR HYDRAULIC OIL AND  
NEUTRAL LIQUIDS (UP TO 75 BAR)

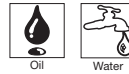

# 3/2

Actuation	Body	Function	Port Size	Orifice (mm)	Flow Factor Kv(l/min)	MOPD (bar)	Max Fluid Temp. (°C)	Page Parker Valve
Pilot Operated	Anodized Aluminium/ Pipe Mounting	Normally Closed	1/4"	8	10	40	75	210

### 3 WAY VALVES

# 3/2

## VALVES FOR HYDRAULIC OIL AND NEUTRAL LIQUIDS (UP TO 75 BAR) PILOT OPERATED

ANODIZED ALUMINIUM  
PIPE MOUNTING

**NORMALLY CLOSED**

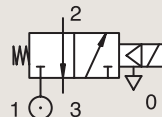

Port size	Orifice Ø		Flow factors			Operating Pressure Differential			Fluid Temp.		Seat Seal	Valve Ref.	Housing Ref.	Coil Ref.	Power		Coil Group	Dwg. No.	
	1	(2)	1	(2)	1	(2)	Min	Max (MOPD)	Min	Max					AC W	DC W			
BSP	mm		Kv l/min		KV m³/h		AC bar	DC bar	°C	°C									
1/4"	8	8	10	10	0.6	0.6	1	40	40	-10	75	NBR	331B02 <sub>12</sub>	2995	481865	8	9	2.1	8114
	8	8	10	10	0.6	0.6	1	40	40	-10	75	NBR	331B02 <sub>12</sub>	4270	481000	8	8	2.1	8114
	8	8	10	10	0.6	0.6	1	40	40	-10	75	NBR	331B0216 <sub>13</sub>	2995	481865	8	9	2.1	8114
	8	8	10	10	0.6	0.6	1	40	40	-10	75	NBR	331B0216 <sub>13</sub>	4270	481000	8	8	2.1	8114

**Notes:**

1. Pilot seat discs in Kel-F (PCTFE); valve with pilot return pipe
2. Valve only compatible with hydraulic oil
3. Pilot seat disk in PUR; valve only compatible with air/neutral gases



### 3 WAY VALVES



For this page	Port size	Orifice (mm)	Kv (l/min)	MOPD (bar)	Fluid Temp (°C)
From	1/4"	8	10	40	-10
To	1/4"	8	10	40	75

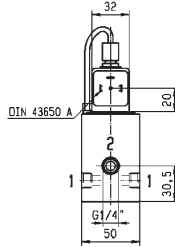
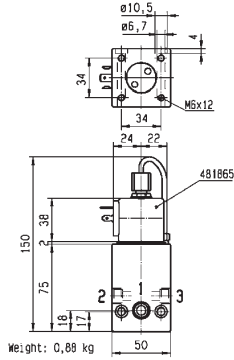

Drawing 8114



## 3 WAY VALVES



### HIGH CORROSION RESISTANT VALVES (303 STAINLESS ST.)

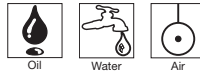

# 3/2

Actuation	Body	Function	Port Size	Orifice (mm)	Flow Factor Kv(l/min)	MOPD (bar)	Max Fluid Temp. (°C)	Page Parker Valve
Direct Operated	303 Stainless St./Pipe Mounting	Normally Closed	1/4"	1 to 2.5	3	15	180	214
		Universal	1/4"	1.5 to 2.5	3.5	10	180	216

### 3 WAY VALVES

# 3/2

## HIGH CORROSION RESISTANT VALVES (303 STAINLESS ST.) DIRECT OPERATED

### 303 STAINLESS ST.

### PIPE MOUNTING

### NORMALLY CLOSED

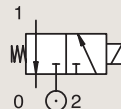

Port size	Orifice Ø		Flow factors				Operating Pressure Differential			Fluid Temp.		Seat Seal	Valve Ref.	Housing Ref.	Coil Ref.	IS	Power		Coil Group	Dwg. No.
	1	(2)	1	(2)	1	(2)	Min	Max (MOPD)	Max	Min	Max						AC W	DC W		
	mm		Kv l/min	KV m <sup>3</sup> /h	bar	AC bar	DC bar	°C	°C											
1/4"	1	1	0.6	0.6	0.04	0.04	0	-	10	-10	55	FKM	131V5490	2995	48358001	*	-	0.5-3	7.0/8.0	6740
	1	1	0.6	0.6	0.04	0.04	0	-	10	-10	75	FKM	131V5490	-	495910	*	-	0.3-1.2	7.0/8.0	6740
	1.5	1.5	1.5	1.5	0.09	0.09	0	15	15	-10	120	FKM	131V5406	4270	481000		8	8	2.1	8116
	1.5	1.5	1.5	1.5	0.09	0.09	0	15	15	-10	100	FKM	131V5406	2995	481865		8	9	2.1	8116
	1.5	1.5	1.5	1.5	0.09	0.09	0	15	15	0	130	Ruby	131V5463 <sub>1</sub>	4270	481000		8	8	2.0	8116
	1.5	1.5	1.5	1.5	0.09	0.09	0	15	15	0	100	Ruby	131V5463 <sub>1</sub>	2995	481865		8	9	2.0	8116
	1.5	1.5	1.5	1.5	0.09	0.09	0	15	15	0	180	Ruby	131V5463 <sub>1</sub>	4270	486265		14	14	2.0	8116
	1.5	1.5	1.5	1.5	0.09	0.09	0	-	7	-20	75	PUR	131V5497	2995	482740		-	1.6	6.0/8.0	8024
	1.5	1.5	1.5	1.5	0.09	0.09	0	7	7	-20	75	PUR	131V5497	-	495900		2.5	2	6.0/8.0	8024
	1.5	1.5	1.5	1.5	0.09	0.09	0	-	7	-20	75	PUR	131V5497	-	495910	*	-	0.3-1.2	6.0/8.0	8024
	1.5	1.5	1.5	1.5	0.09	0.09	0	-	7	-20	65	PUR	131V5497	2995	496125		-	1.6	6.0/8.0	8024
	2.5	2.5	3.5	3.5	0.21	0.21	0	7	7	-10	120	FKM	131V5306	4270	481000		8	8	2.1	8116
	2.5	2.5	3.5	3.5	0.21	0.21	0	7	7	-10	100	FKM	131V5306	2995	481865		8	9	2.1	8116
	2.5	2.5	3.5	3.5	0.21	0.21	0	7	7	-30	130	Ruby	131V5363 <sub>1</sub>	4270	481000		8	8	2.0	8116
	2.5	2.5	3.5	3.5	0.21	0.21	0	7	7	-30	100	Ruby	131V5363 <sub>1</sub>	2995	481865		8	9	2.0	8116
	2.5	2.5	3.5	3.5	0.21	0.21	0	7	7	-30	180	Ruby	131V5363 <sub>1</sub>	4270	486265		14	14	2.0	8116
	2.5	2.5	3	3	0.18	0.18	0	-	2	-20	75	PUR	131V5397	2995	482740		-	1.6	6.0/8.0	8024
	2.5	2.5	3	3	0.18	0.18	0	2	2	-20	75	PUR	131V5397	-	495900		2.5	2	6.0/8.0	8024
	2.5	2.5	3	3	0.18	0.18	0	-	2	-20	75	PUR	131V5397	-	495910	*	-	0.3-1.2	6.0/8.0	8024
	2.5	2.5	3	3	0.18	0.18	0	-	2	-20	65	PUR	131V5397	2995	496125		-	1.6	6.0/8.0	8024
1/4" NPT	1	1	0.6	0.6	0.04	0.04	0	-	10	-10	55	FKM	U131V5490	2995	483580.01	*	-	0.5-3	7.0/8.0	6740
	1.5	1.5	1.5	1.5	0.09	0.09	0	15	15	-10	100	FKM	U131V5406	2995	481865		8	9	2.1	8116
	1.5	1.5	1.5	1.5	0.09	0.09	0	15	15	0	100	Ruby	U131V5463	2995	481865		8	9	2.0	8116
	2.5	2.5	3.5	3.5	0.21	0.21	0	7	7	-10	100	FKM	U131V5306	2995	481865		8	9	2.1	8116
	2.5	2.5	3.5	3.5	0.21	0.21	0	7	7	-30	100	Ruby	U131V5363	2995	481865		8	9	2.0	8116

**Notes:**

1. Valve only compatible with hydraulic oil and neutral liquids



### 3 WAY VALVES



For this page	Port size	Orifice (mm)	Kv (l/min)	MOPD (bar)	Fluid Temp (°C)
From	1/4"	1	0.6	2	-30
To	1/4"	2.5	3.5	15	180

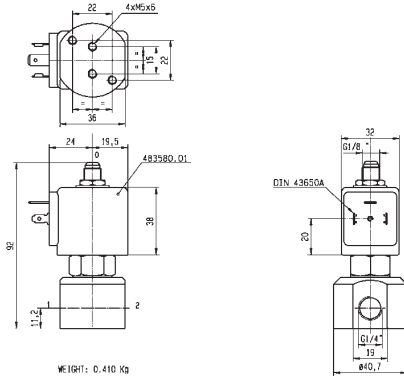

Drawing 6740

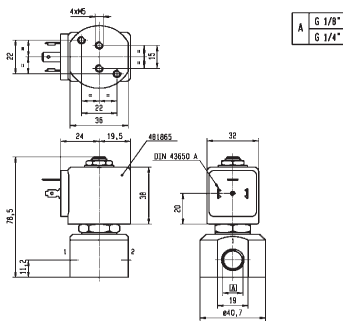

Drawing 8116

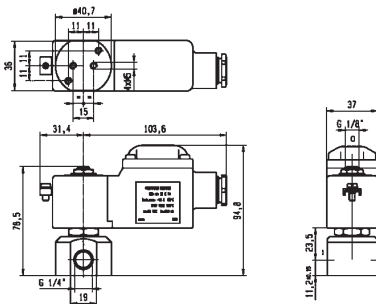

Drawing 8024



### 3 WAY VALVES

# 3/2

## HIGH CORROSION RESISTANT VALVES (303 STAINLESS ST.) DIRECT OPERATED

### 303 STAINLESS ST.

### PIPE MOUNTING

### UNIVERSAL

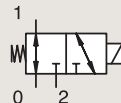

Port size	Orifice Ø		Flow factors			Operating Pressure Differential			Fluid Temp.		Seat Seal	Valve Ref.	Housing Ref.	Coil Ref.	Power		Coil Group	Dwg. No.	
	1	(2)	1	(2)	1	(2)	Min	Max (MOPD)	Min	Max					AC W	DC W			
BSP	mm		Kv l/min		KV m³/h		bar	AC bar	DC bar	°C	°C								
1/4"	1.5	1.5	1.5	1.5	0.09	0.09	0	10	10	-10	120	FKM	133V5406	4270	481000	8	8	2.1	8116
	1.5	1.5	1.5	1.5	0.09	0.09	0	10	10	-10	100	FKM	133V5406	2995	481865	8	9	2.1	8116
	1.5	1.5	1.5	1.5	0.09	0.09	0	10	10	0	130	Ruby	133V5463 <sub>1</sub>	4270	481000	8	8	2.0	8116
	1.5	1.5	1.5	1.5	0.09	0.09	0	10	10	0	100	Ruby	133V5463 <sub>1</sub>	2995	481865	8	9	2.0	8116
	1.5	1.5	1.5	1.5	0.09	0.09	0	10	10	0	180	Ruby	133V5463 <sub>1</sub>	4270	486265	14	14	2.0	8116
	2.5	2.5	3.5	3.5	0.21	0.21	0	4	4	-10	120	FKM	133V5306	4270	481000	8	8	2.1	8116
	2.5	2.5	3.5	3.5	0.21	0.21	0	4	4	0	130	Ruby	133V5363 <sub>1</sub>	4270	481000	8	8	2.0	8116
	2.5	2.5	3.5	3.5	0.21	0.21	0	4	4	0	100	Ruby	133V5363 <sub>1</sub>	2995	481865	8	9	2.0	8116
	2.5	2.5	3.5	3.5	0.21	0.21	0	4	4	0	180	Ruby	133V5363 <sub>1</sub>	4270	486265	14	14	2.0	8116
1/4" NPT	1.5	1.5	1.5	1.5	0.09	0.09	0	10	10	-10	100	FKM	U133V5406	2995	481865	8	9	2.1	8116
	1.5	1.5	1.5	1.5	0.09	0.09	0	10	10	0	100	Ruby	U133V5463	2995	481865	8	9	2.0	8116
	2.5	2.5	3.5	3.5	0.21	0.21	0	4	4	-10	100	FKM	U133V5306	2995	481865	8	9	2.1	8116
	2.5	2.5	3.5	3.5	0.21	0.21	0	4	4	0	100	Ruby	U133V5363	2995	481865	8	9	2.0	8116

**Notes:**

1. Valve only compatible with hydraulic oil and neutral liquids



### 3 WAY VALVES



For this page	Port size	Orifice (mm)	Kv (l/min)	MOPD (bar)	Fluid Temp (°C)
From	1/4"	1.5	1.5	4	-10
To	1/4"	2.5	3.5	10	180

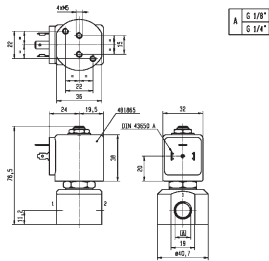

Drawing 8116



## 3 WAY VALVES



### VALVES FOR BEVERAGE DISPENSING AND LIQUIPURE®



# 3/2

Actuation	Body	Function	Port Size	Orifice (mm)	Flow Factor Kv(l/min)	MOPD (bar)	Max Fluid Temp. (°C)	Page Parker Valves
Direct Operated	Stainless St./Pipe Mounting	Normally Closed	1/8"	1.5 to 2.5	1 to 2.3	8	140	220
			1/4"	1.5 to 3	1 to 4.5	8	140	220
	LLB Brass/Pipe Mounting	Normally Closed	1/8"	1.5 to 3	1.4 to 3.7	20	140	222
			1/4"	1.5 to 5	1.4 to 4.3	20	140	224
	LLB Brass/Sub-Base Mounting	Normally Closed	SB	1.5 to 3	1.3 to 3.7	20	140	226
Stainless St./Sub-base Mounting	Normally Closed	SB	1.5 to 5	7.2	14	140	228	

## 3 WAY VALVES

# 3/2

VALVES FOR BEVERAGE DISPENSING -  
LIQUIPURE®  
DIRECT OPERATED

STAINLESS ST.

301LG SERIES - 3

**NORMALLY CLOSED**

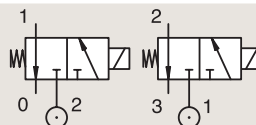

Port Size	Orifice	Flow Factors		Operating Pressure Differential			Fluid Temperature		Seat Seal	Parker Valves		Power		Coil Group	Fluid Compatibility	Class Column
		kv	Kv	Min. Bar	Max. (MOPD) AC bar	DC bar	Min. °C	Max. °C		Valve Ref.	Coil Ref.	AC W	DC W			
1/8"	1.5	1	0.06	0	8	8	-10	140	FKM	301LG1GVG2	481180	4	5	1.1/1.3	A	4
	2.5	2.3	0.14	0	3	3	-10	140	FKM	301LG1LVG2	481180	4	5	1.1/1.3	A	4
1/4"	1.5	1	0.06	0	8	8	-10	140	FKM	301LG2GVG2	481180	4	5	1.1/1.3	A	4
	2.5	2.3	0.14	0	3	3	-10	140	FKM	301LG2LVG2	481180	4	5	1.1/1.3	A	4
	1.5	1	0.06	0	12	12	-10	140	FKM	301LG2GVG7	481865	8	9	24/2.0	A	5
	3.0	4.5	0.27	0	4	4	-10	140	FKM	301LG2NVG7	481865	8	9	24/2.0	A	5



## 3 WAY VALVES



For this page	Port size	Orifice (mm)	Kv (l/min)	MOPD (bar)	Fluid Temp (°C)
From	1/8"	1.5	1	3	-10
To	1/4"	3	4.5	8	140

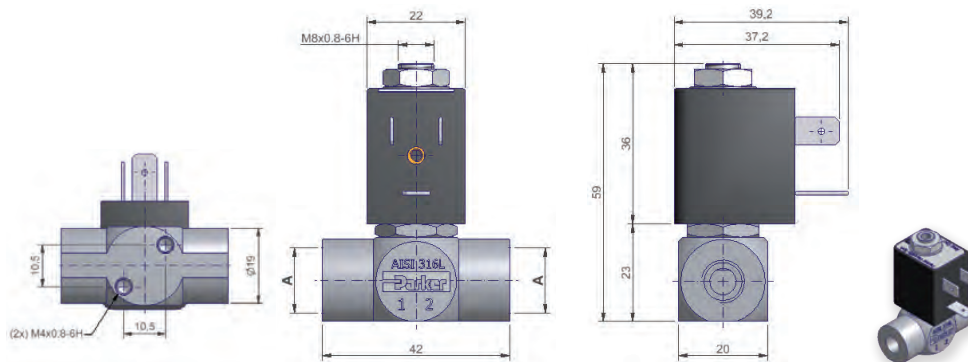

Drawing 4

All dimensions are in mm

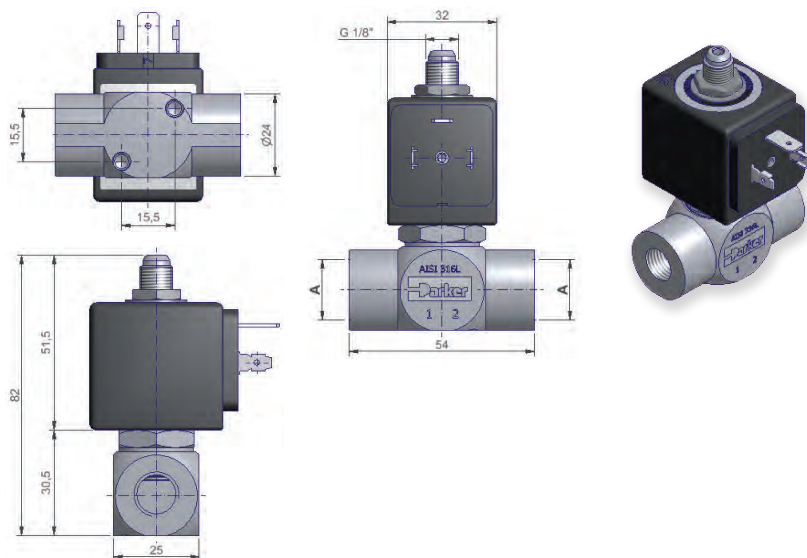

All dimensions are in mm

Drawing 5



## 3 WAY VALVES

# 3/2

## VALVES FOR BEVERAGE DISPENSING - LIQUIPURE® DIRECT OPERATED

Our Parker range of healthy solenoid valves provides you with top-class performance as a result of the entire stainless steel structure of the valve pilots.

Compact and robust at the same time, the stainless steel nozzle included in all 32mm operated range improves valve life, endurance and resistance to lime-scale build up effect. A wide range of electrical parts can be used with this valve, including IP65 VDE and UL solutions. Typical applications include cold water loading function or hot water-steam on/off control.

Valve body: forged brass, CW510L UNI EN 12165

Seals: FDA FKM, Ruby

Sleeve, plungers and nozzle: stainless steel



### CW510L BRASS BODY

### PIPE MOUNTING

### NORMALLY CLOSED

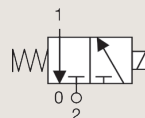

Port Size	Orifice Ø mm	Flow Factors Kv l/min	KV m³/h	Operating Pressure Differential			Fluid Temperature		Seat Seal	Parker Valves			Power		Coil Group	Dwg N°
				Min. Bar	Max. (MOPD) AC bar	DC bar	Min. °C	Max. °C		Valve Ref.	Housing Ref.	Coil Ref.	AC W	DC W		
G1/8"	1.5	1.4	0.08	0	20	20	-10	140	FDA FKM	131ZH1115	2995	481865	9	8	2.0, 2.1, 2.2	5
	2.0	2.0	0.12	0	14	14	-10	140	FDA FKM	131ZH1120	2995	481865	9	8	2.0, 2.1, 2.2	
	2.5	3.0	0.18	0	8.5	8.5	-10	140	FDA FKM	131ZH1125	2995	481865	9	8	2.0, 2.1, 2.2	
	3.0	3.7	0.22	0	6	6	-10	140	FDA FKM	131ZH1130	2995	481865	9	8	2.0, 2.1, 2.2	
	1.5	1.4	0.08	0	20	20	-10	140	Ruby	131ZH1115	2995	481865	9	8	2.0, 2.1, 2.2	
	2.0	2.0	0.12	0	14	14	-10	140	Ruby	131ZH1120	2995	492425	9	8	2.0, 2.1, 2.2	
G1/8"	2.5	3.0	0.18	0	8.5	8.5	-10	140	Ruby	131ZH0125	2995	481865	9	8	2.0, 2.1, 2.2	6
	3.0	3.7	0.22	0	6	6	-10	140	Ruby	131ZH0130	2995	481865	9	8	2.0, 2.1, 2.2	
	1.5	1.4	0.10	0	20	20	-10	140	FDA FKM	131ZH1315	2995	481865	9	8	2.0, 2.1, 2.2	
	2.0	2.0	0.10	0	14	14	-10	140	FDA FKM	131ZH1320	2995	481865	9	8	2.0, 2.1, 2.2	
	2.5	3.0	0.20	0	8.5	8.5	-10	140	FDA FKM	131ZH1325	2995	481865	9	8	2.0, 2.1, 2.2	
	3.0	3.7	0.20	0	6	6	-10	140	FDA FKM	31ZH1330	2995	481865	9	8	2.0, 2.1, 2.2	
	1.5	1.4	0.1	0	20	20	-10	140	Ruby	131ZH0315	2995	481865	9	8	2.0, 2.1, 2.2	
	2.0	2.0	0.1	0	14	14	-10	140	Ruby	131ZH0320	2995	481865	9	8	2.0, 2.1, 2.2	
	2.5	3.0	0.2	0	8.5	8.5	-10	140	Ruby	131ZH0325	2995	481865	9	8	2.0, 2.1, 2.2	
	3.0	3.7	0.2	0	6	6	-10	140	Ruby	131ZH0330	2995	481865	9	8	2.0, 2.1, 2.2	
NPT 1/8"	1.5	1.4	0.08	0	20	20	-10	140	FDA FKM	U131ZH1115	2995	481865	9	8	2.0, 2.1, 2.2	5
	2.0	2.0	0.12	0	14	14	-10	140	FDA FKM	U131ZH1120	2995	481865	9	8	2.0, 2.1, 2.2	
	2.5	3.0	0.18	0	8.5	8.5	-10	140	FDA FKM	U131ZH1125	2995	481865	9	8	2.0, 2.1, 2.2	
	3.0	3.7	0.22	0	6	6	-10	140	FDA FKM	U131ZH1130	2995	481865	9	8	2.0, 2.1, 2.2	
	1.5	1.4	0.08	0	20	20	-10	140	Ruby	U131ZH0115	2995	481865	9	8	2.0, 2.1, 2.2	
	2.0	2.0	0.12	0	14	14	-10	140	Ruby	U131ZH0120	2995	481865	9	8	2.0, 2.1, 2.2	
	2.5	3.0	0.18	0	8.5	8.5	-10	140	Ruby	U131ZH0125	2995	481865	9	8	2.0, 2.1, 2.2	
3.0	3.7	0.22	0	6	6	-10	140	Ruby	U131ZH0130	2995	481865	9	8	2.0, 2.1, 2.2		



## 3 WAY VALVES



For this page	Port size	Orifice (mm)	Kv (l/min)	MOPD (bar)	Fluid Temp (°C)
From	1/8"	1.5	1.4	6	-10
To	1/4"	3	3.7	20	140
From	SB	1.5	1.3	7.5	-10
To	SB	3	3	20	140

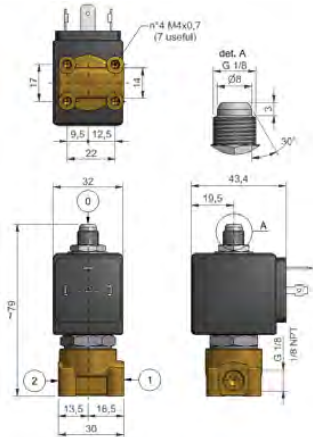

Drawing 5

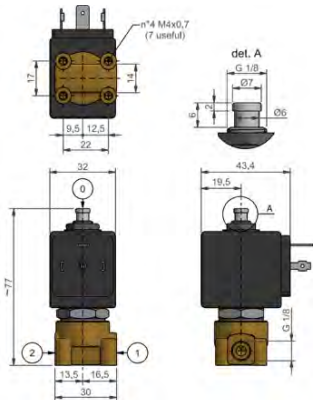

Drawing 6

## 3 WAY VALVES

# 3/2

### VALVES FOR BEVERAGE DISPENSING - LIQUIPURE® DIRECT OPERATED

Our Parker range of healthy solenoid valves provides you with top-class performance as a result of the entire stainless steel structure of the valve pilots.

Compact and robust at the same time, the stainless steel nozzle included in all 32mm operated range improves valve life, endurance and resistance to lime-scale build up effect. A wide range of electrical parts can be used with this valve, including IP65 VDE and UL solutions. Typical applications include cold water loading function or hot water-steam on/off control.

Valve body: forged brass, CW510L UNI EN 12165

Seals: FDA FKM, Ruby

Sleeve, plungers and nozzle: stainless steel



### CW510L BRASS BODY

### PIPE MOUNTING

### NORMALLY CLOSED

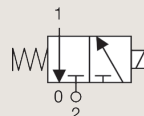

Port Size	Orifice Ø			Flow Factors			Operating Pressure Differential			Fluid Temperature		Seat Seal	Parker Valves			Power		Coil Group	Dwg N°
	mm	Kv l/min	KV m³/h	Min. Bar	Max. (MOPD) AC bar	DC bar	Min. °C	Max. °C	Valve Ref.	Housing Ref.	Coil Ref.		AC W	DC W					
G1/4"	1.5	1.4	0.08	0	20	20	-10	140	FDA FKM	131KH1115	2995	481865	9	8	2.0, 2.1, 2.2	7			
	2.0	2.0	0.12	0	14	14	-10	140	FDA FKM	131KH1120	2995	481865	9	8	2.0, 2.1, 2.2				
	2.5	3.0	0.18	0	8.5	8.5	-10	140	FDA FKM	131KH1125	2995	481865	9	8	2.0, 2.1, 2.2				
	3.0	3.7	0.22	0	6	6	-10	140	FDA FKM	131KH1130	2995	481865	9	8	2.0, 2.1, 2.2	8			
	4.0	5.2	0.31	0	3.5	3.5	-10	140	FDA FKM	131KH1140	2995	481865	9	8	2.0, 2.1, 2.2				
	5.0	9.3	0.56	0	2	2	-10	140	FDA FKM	131KH1150	2995	492425	14	14	2.0, 2.1, 2.2				
	1.5	1.4	0.08	0	20	20	-10	140	Ruby	131KH0115	2995	481865	9	8	2.0, 2.1, 2.2	7			
	2.0	2.0	0.12	0	14	14	-10	140	Ruby	131KH0120	2995	481865	9	8	2.0, 2.1, 2.2				
	2.5	3.0	0.18	0	8.5	8.5	-10	140	Ruby	131KH0125	2995	481865	9	8	2.0, 2.1, 2.2				
	30	3.7	0.22	0	6	6	-10	140	Ruby	131KH0130	2995	481865	9	8	2.0, 2.1, 2.2				

## 3 WAY VALVES



For this page	Port size	Orifice (mm)	Kv (l/min)	MOPD (bar)	Fluid Temp (°C)
From	1/8"	1.5	1.4	6	-10
To	1/4"	3	3.7	20	140
From	SB	1.5	1.3	7.5	-10
To	SB	3	3	20	140

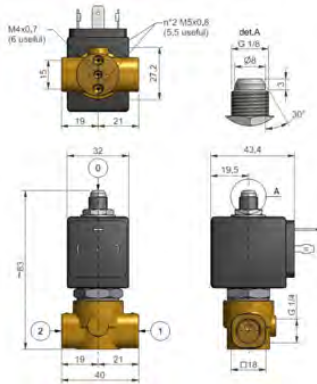

Drawing 7

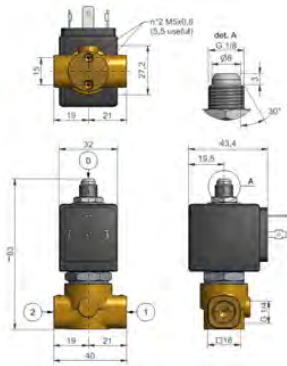

Drawing 8

## 3 WAY VALVES

# 3/2

## VALVES FOR BEVERAGE DISPENSING - LIQUIPURE® DIRECT OPERATED

Our Parker range of healthy solenoid valves provides you with top-class performance as a result of the entire stainless steel structure of the valve pilots.

Compact and robust at the same time, the stainless steel nozzle included in all 32mm operated range improves valve life, endurance and resistance to lime-scale build up effect. A wide range of electrical parts can be used with this valve, including IP65 VDE and UL solutions. Typical applications include cold water loading function or hot water-steam on/off control.

Valve body: forged brass, CW510L UNI EN 12165

Seals: FD A FKM, Ruby

Sleeve, plungers and nozzle: stainless steel



### CW510L BRASS BODY FLANGED (SB)

#### NORMALLY CLOSED

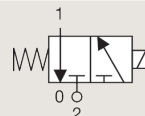

Port Size	Orifice Ø	Flow Factors		Operating Pressure Differential			Fluid Temperature		Seat Seal	Parker Valves			Power		Coil Group	Dwg N°
		Kv	KV	Min.	Max. (MOPD)	Min.	Max.	Valve Ref.		Housing Ref.	Coil Ref.	AC W	DC W			
	mm	l/min	m³/h	Bar	AC bar	DC bar	°C	°C								
SB	1.5	1.4	0.08	0	20	20	-10	140	FDA FKM	131FH1115	2995	481865	9	8	2.0, 2.1, 2.2	9
	2.0	2.0	0.12	0	15	15	-10	140	FDA FKM	131FH1120	2995	481865	9	8	2.0, 2.1, 2.2	
	2.5	3.0	0.16	0	10	10	-10	140	FDA FKM	131FH1125	2995	481865	9	8	2.0, 2.1, 2.2	
	3.0	3.7	0.18	0	7.5	7.5	-10	140	FDA FKM	131FH1130	2995	481865	9	8	2.0, 2.1, 2.2	
	1.5	1.4	0.08	0	20	20	-10	140	Ruby	131FH1115	2995	481865	9	8	2.0, 2.1, 2.2	
	2.0	2.0	0.12	0	15	15	-10	140	Ruby	131FH1120	2995	481865	9	8	2.0, 2.1, 2.2	
	2.5	3.0	0.16	0	10	10	-10	140	Ruby	131FH1125	2995	481865	9	8	2.0, 2.1, 2.2	
SB	3.0	3.7	0.18	0	7.5	7.5	-10	140	Ruby	131FH1130	2995	481865	9	8	2.0, 2.1, 2.2	10
	1.5	1.4	0.08	0	20	20	-10	140	FDA FKM	131FH1315	2995	481865	9	8	2.0, 2.1, 2.2	
	2.0	2.0	0.12	0	15	15	-10	140	FDA FKM	131FH1320	2995	481865	9	8	2.0, 2.1, 2.2	
	2.5	3.0	0.16	0	10	10	-10	140	FDA FKM	131FH1325	2995	481865	9	8	2.0, 2.1, 2.2	
	3.0	3.7	0.18	0	7.5	7.5	-10	140	FDA FKM	131FH1330	2995	481865	9	8	2.0, 2.1, 2.2	
	1.5	1.4	0.08	0	20	20	-10	140	Ruby	131FH0315	2995	481865	9	8	2.0, 2.1, 2.2	
	2.0	2.0	0.12	0	15	15	-10	140	Ruby	131FH0320	2995	481865	9	8	2.0, 2.1, 2.2	
2.5	3.0	0.16	0	10	10	-10	140	Ruby	131FH0325	2995	481865	9	8	2.0, 2.1, 2.2		
3.0	3.7	0.18	0	7.5	7.5	-10	140	Ruby	131FH0330	2995	481865	9	8	2.0, 2.1, 2.2		



## 3 WAY VALVES



For this page	Port size	Orifice (mm)	Kv (l/min)	MOPD (bar)	Fluid Temp (°C)
From	1/8"	1.5	1.4	6	-10
To	1/4"	3	3.7	20	140
From	SB	1.5	1.3	7.5	-10
To	SB	3	3	20	140

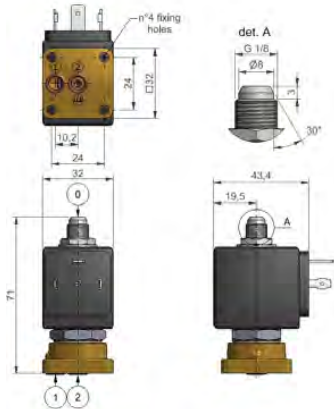

Drawing 9

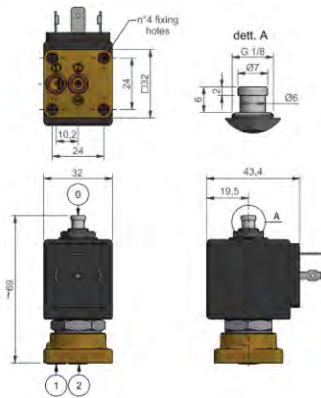

Drawing 10

### 3 WAY VALVES

# 3/2

## VALVES FOR BEVERAGE DISPENSING - LIQUIPURE® DIRECT OPERATED



Beverage Dispensing



Medical / Instrumentation

### STAINLESS ST. SUB-BASE MOUNTING NORMALLY CLOSED

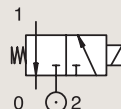

Port size	Orifice Ø		Flow factors				Operating Pressure Differential		Fluid Temp.		Seat Seal	Parker Valves			Power		Coil Group	Dwg. No.	Compatible adapter kit	
	1	(2)	1	(2)	1	(2)	Min	Max	Min	Max		Valve Ref.	Hou Ref.	Coil Ref.	AC W	DC W				
BSP	1.5	2.5	1.3	2.9	0.08	0.17	0	14	14	-10	140	Ruby	3019F1GRG7	-	481865	8	9	2.0	72	XGSPG1-XGSPG2
	1.5	2.5	1.3	2.9	0.08	0.17	0	14	14	-10	140	FKM FDA	3019F1GVG7	-	481865	8	9	2.0	72	XGSPG1-XGSPG2
	2	2.5	2.2	2.9	0.13	0.17	0	10	10	-10	140	Ruby	3019F1JRG7	-	481865	8	9	2.0	72	XGSPG1-XGSPG2
	2	2.5	2.2	2.9	0.13	0.17	0	10	10	-10	140	FKM FDA	3019F1JVG7	-	481865	8	9	2.0	72	XGSPG1-XGSPG2
	2	2.5	2.2	2.9	0.13	0.17	0	10	10	-10	140	Ruby	301XGFRTJ7	-	481865	8	9	2.0	72	XGSPG1-XGSPG2
SB	2.5	2.5	2.8	2.9	0.17	0.17	0	6.5	6.5	-10	140	Ruby	3019F1LRG7	-	481865	8	9	2.0	72	XGSPG1-XGSPG2
	2.5	2.5	2.8	2.9	0.17	0.17	0	6.5	6.5	-10	140	FKM FDA	3019F1LVG7	-	481865	8	9	2.0	72	XGSPG1-XGSPG2
	3	2.5	3.3	2.9	0.2	0.17	0	4	4	-10	140	Ruby	3019F1NRG7	-	481865	8	9	2.0	72	XGSPG1-XGSPG2
	3	2.5	3.3	2.9	0.2	0.17	0	4	4	-10	140	FKM FDA	3019F1NVG7	-	481865	8	9	2.0	72	XGSPG1-XGSPG2
	4	2.5	6.5	2.9	0.39	0.17	0	3	3	-10	140	FKM FDA	3019F1QVG7	-	481865	8	9	2.0	72	XGSPG1-XGSPG2
	4	4.0	6.5	2.9	0.39	0.17	0	3	3	-10	140	EPDM	3019F1QEG7	-	481865	8	9	2.0	72	XGSPG1-XGSPG2
	5	2.5	7.2	2.9	0.43	0.17	0	2	2	-10	140	FKM FDA	3019F1SVG7	-	481865	8	9	2.0	72	XGSPG1-XGSPG2
	5	5.0	7.2	2.9	0.43	0.17	0	2	2	-10	140	EPDM	3019F1SEG7	-	481865	8	9	2.0	72	XGSPG1-XGSPG2

Important: pressure vessels included in this page are supplied with the standard 2995 housing integrated.



### 3 WAY VALVES



For this page	Port size	Orifice (mm)	Kv (l/min)	MOPD (bar)	Fluid Temp (°C)
From	SB	1.5	1.3	10	-10
To	SB	2	2.2	14	140

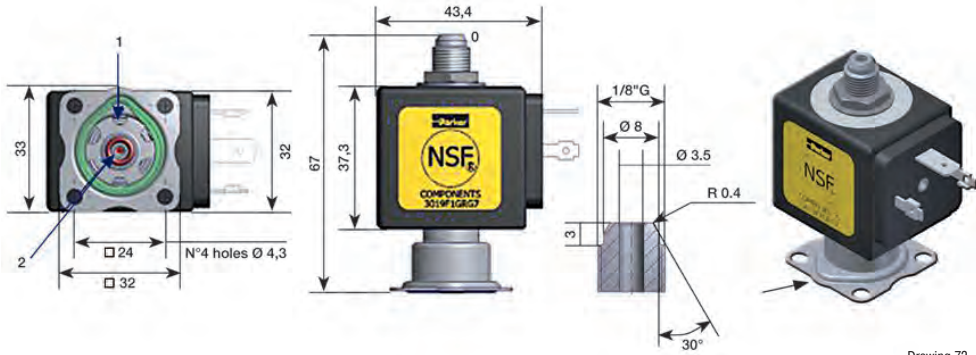

Drawing 72

**3 WAY VALVES**

# 3/2

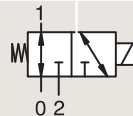
**VALVES FOR BEVERAGE DISPENSING - LIQUIPURE® DIRECT OPERATED**
**3/2 UNIVERSAL**
**1/8" G THREADED MALE EXHAUST PORT**
**NORMALLY CLOSED**

Port Size	Orifice mm		Flow Factors				Operating Pressure Differential			Fluid Temp.		Seat Seal	Reference		Power		Coil Group	Compatible Adapter Kit
			1		(2)		Min.	Max. (MOPD)	Min.	Max.	Valve Reference		Coil Ref.	AC W	DC W			
			Kv l/min	KV m³/h	Kv l/min	KV m³/h										bar		
SB	1.5	1.5	1.4	0.08	1.3	0.8	0	9.5	9.5	-10	140	FKM FDA	3039F1GVG7	481865	9	8	24.0	XGSPG1 - XGSPG2
	1.5	1.5	1.4	0.08	1.3	0.08	0	9.5	9.5	-10	140	EPDM	3039F1GEG7	481865	9	8	24.0	XGSPG1 - XGSPG2
	2.0	2.0	2.1	0.13	2.0	0.12	0	3.5	3.5	-10	140	FKM FDA	3039F1JVG7	481865	9	8	24.0	XGSPG1 - XGSPG2
	2.0	2.0	2.1	0.13	2.0	0.12	0	3.5	3.5	-10	140	EPDM	3039F1JEG7	481865	9	8	24.0	XGSPG1 - XGSPG2
	2.5	2.5	2.8	0.17	2.8	0.17	0	2	2	-10	140	FKM FDA	3039F1LVG7	481865	9	8	24.0	XGSPG1 - XGSPG2
	2.5	2.5	2.8	0.17	2.8	0.168	0	2	2	-10	140	EPDM	3039F1LEG7	481865	9	8	24.0	XGSPG1 - XGSPG2
	3.0	2.5	3.3	0.2	2.8	0.17	0	2	2	-10	140	FKM FDA	3039F1NVG7	481865	9	8	24.0	XGSPG1 - XGSPG2
	3.0	2.5	3.3	0.2	2.8	0.168	0	2	2	-10	140	EPDM	3039F1NEG7	481865	9	8	24.0	XGSPG1 - XGSPG2

Nominal Pressure = 20 bar

Notes:

1. NSF Certified



### 3 WAY VALVES



For this page	Port size	Orifice (mm)	Kv (l/min)	MOPD (bar)	Fluid Temp (°C)
From	SB	1.5	1.4	2	-10
To	SB	3	3.3	9.5	140

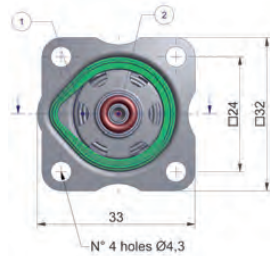
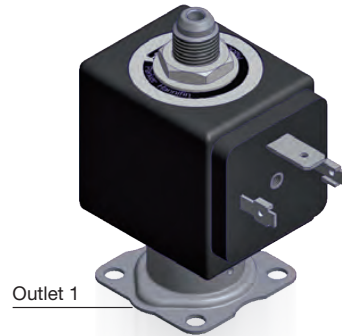
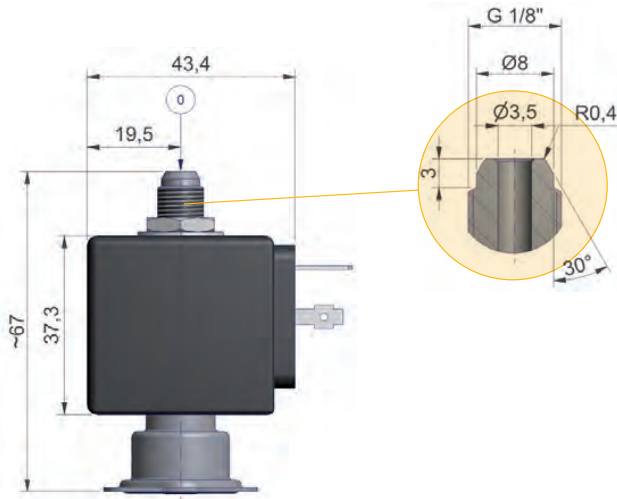

All dimensions are in mm





## 2 & 3 WAY VALVES FOR TRANSPORTATION



### 2 WAY VALVES FOR TRANSPORTATION



Water

# 2/2

Actuation	Body	Function	Port Size	Orifice (mm)	Flow Factor Kv(l/min)	MOPD (bar)	Max Fluid Temp. (°C)	Page Parker Valves
Pilot Operated	Brass/Quick Coupling	Normally Closed	10 mm	11	12	3	90	234
	Brass/Barb Fitting	Normally Closed	10 mm	11	12	3	90	234
	Brass/Pipe Mounting	Normally Closed	1/2"	11	36	3	90	236
			12.7 mm	11	33	3	90	236
			15.9 mm	11	36	3	90	236

2 & 3 WAY  
VALVES FOR  
TRANSPORTATION

# 2/2

## 2 WAY VALVES FOR TRANSPORTATION

### PILOT OPERATED



Transportation

BRASS

QUICK COUPLING

**NORMALLY CLOSED**

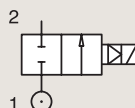

Port size	Orifice Ø mm	Flow factors			Operating Pressure Differential			Fluid Temp.		Seat Seal	Valve Ref.	Housing Ref.	Coil Ref.	Voltage	Power		Coil Group	Dwg. No.
		Kv l/min	KV m³/h	Qn l/min	Min bar	Max(MOPD) AC bar	DC bar	Min °C	Max °C						AC W	DC W		
10 mm	11	12	0.72	-	0.2	-	3	-40	90	EPDM	321K1543	2168	495294	12 VDC	-	9	13.0	8242
	11	12	0.72	-	0.2	-	3	-40	90	EPDM	321K1543	2169	495294	24 VDC	-	9	13.0	8242
	11	12	0.72	-	0.2	-	3	-40	90	EPDM	321K1543	2168	496193	12 VDC	-	9	13.0	8242
	11	12	0.72	-	0.2	-	3	-40	90	EPDM	321K1543	2169	496193	24 VDC	-	9	13.0	8242

BRASS

BARB FITTING

**NORMALLY CLOSED**

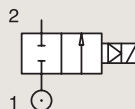

Port size	Orifice Ø mm	Flow factors			Operating Pressure Differential			Fluid Temp.		Seat Seal	Valve Ref.	Housing Ref.	Coil Ref.	Voltage	Power		Coil Group	Dwg. No.
		Kv l/min	KV m³/h	Qn l/min	Min bar	Max(MOPD) AC bar	DC bar	Min °C	Max °C						AC W	DC W		
10 mm	11	12	0.72	-	0.2	-	3	-40	90	EPDM	321K1535	2168	495294	12 VDC	-	9	13.0	8241
	11	12	0.72	-	0.2	-	3	-40	90	EPDM	321K1535	2169	495294	24 VDC	-	9	13.0	8241
	11	12	0.72	-	0.2	-	3	-40	90	EPDM	321K1535	2168	496193	12 VDC	-	9	13.0	8241
	11	12	0.72	-	0.2	-	3	-40	90	EPDM	321K1535	2169	496193	24 VDC	-	9	13.0	8241



**2 & 3 WAY  
VALVES FOR  
TRANSPORTATION**
**UK  
CA CE**

For this page	Port size	Orifice (mm)	Kv (l/min)	MOPD (bar)	Fluid Temp (°C)
From	10 mm	11	12	3	-40
To	10 mm	11	12	3	90

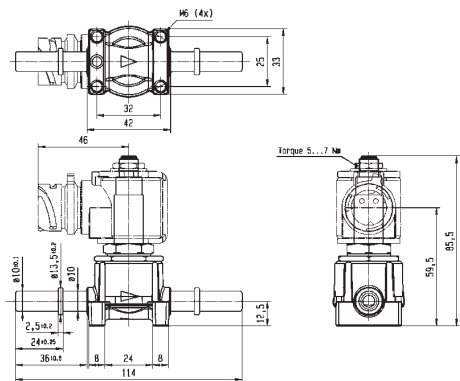

Drawing 8242

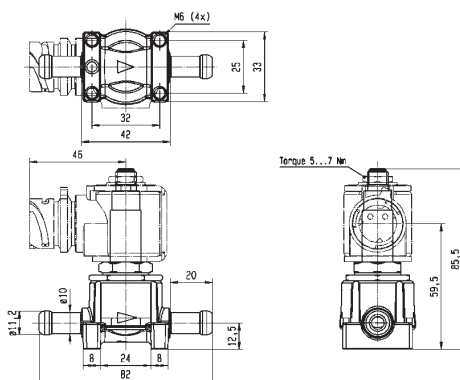

Drawing 8241

# 2/2

## 2 WAY VALVES FOR TRANSPORTATION

### PILOT OPERATED

BRASS

PIPE MOUNTING

NORMALLY CLOSED

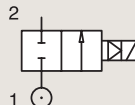

Port size	Orifice Ø mm	Flow factors			Operating Pressure Differential			Fluid Temp.		Seat Seal	Valve Ref.	Housing Ref.	Coil Ref.	Voltage	Power		Coil Group	Dwg. No.
		Kv l/min	KV m³/h	Qn l/min	Min bar	Max(MOPD) AC bar	DC bar	Min °C	Max °C						AC W	DC W		
1/2" BSP	11	36	2.16	-	0.2	-	3	-40	90	EPDM	321K1523	2168	495294	12 VDC	-	9	13.0	8238
	11	36	2.16	-	0.2	-	3	-40	90	EPDM	321K1523	2169	495294	24 VDC	-	9	13.0	8238
	11	36	2.16	-	0.2	-	3	-40	90	EPDM	321K1523	2168	496193	12 VDC	-	9	13.0	8238
	11	36	2.16	-	0.2	-	3	-40	90	EPDM	321K1523	2169	496193	24 VDC	-	9	13.0	8238
12.7 mm	11	33	1.98	-	0.2	-	3	-40	90	EPDM	321K1536	2168	495294	12 VDC	-	9	13.0	8282
	11	33	1.98	-	0.2	-	3	-40	90	EPDM	321K1536	2169	495294	24 VDC	-	9	13.0	8282
	11	33	1.98	-	0.2	-	3	-40	90	EPDM	321K1536	2168	496193	12 VDC	-	9	13.0	8282
	11	33	1.98	-	0.2	-	3	-40	90	EPDM	321K1536	2169	496193	24 VDC	-	9	13.0	8282
15.9 mm	11	36	2.16	-	0.2	-	3	-40	90	EPDM	321K1537	2168	495294	12 VDC	-	9	13.0	8281
	11	36	2.16	-	0.2	-	3	-40	90	EPDM	321K1537	2169	495294	24 VDC	-	9	13.0	8281
	11	36	2.16	-	0.2	-	3	-40	90	EPDM	321K1537	2168	496193	12 VDC	-	9	13.0	8281
	11	36	2.16	-	0.2	-	3	-40	90	EPDM	321K1537	2169	496193	24 VDC	-	9	13.0	8281



**2 & 3 WAY  
VALVES FOR  
TRANSPORTATION**
**UK  
CA CE**

For this page	Port size	Orifice (mm)	Kv (l/min)	MOPD (bar)	Fluid Temp (°C)
From	1/2"	11	33	3	-40
To	15.9 mm	11	36	3	90

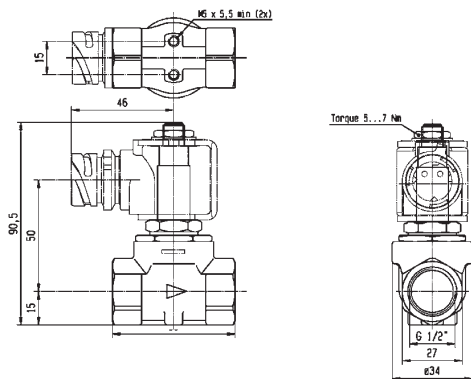

Drawing 8238

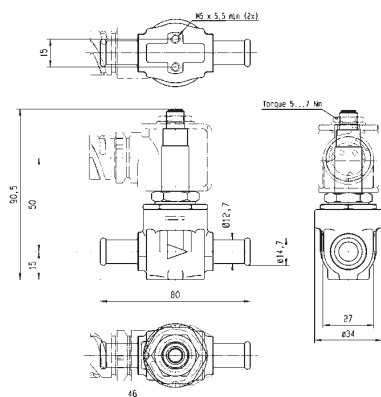

Drawing 8282

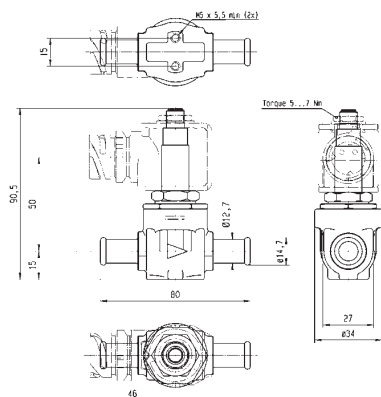

Drawing 8281



2 & 3 WAY VALVES FOR TRANSPORTATION

NOTES

Horizontal lines for taking notes.

## 2 & 3 WAY VALVES FOR TRANSPORTATION

### 3 WAY VALVES FOR TRANSPORTATION



# 3/2

Actuation	Body	Function	Port Size	Orifice (mm)	Flow Factor Kv(l/min)	MOPD (bar)	Max Fluid Temp. (°C)	Page Parker Valves	Page
Direct Operated	Brass/Quick Coupling	Normally Closed	1/8"	1.8	110	8	80	-	240

2 & 3 WAY  
VALVES FOR  
TRANSPORTATION

# 3/2

## 3 WAY VALVES FOR TRANSPORTATION

### DIRECT OPERATED



Transportation

BRASS  
QUICK COUPLING

**NORMALLY CLOSED**

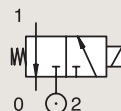

Port size	Orifice $\phi$		Flow factor Qn l/min	Operating Pressure Differential			Fluid Temp.		Seat Seal	Valve Ref.	Housing Ref.	Coil Ref.	Power		Coil Group	Dwg. No.
	1	(2)		Min	Max (MOPD)	Min	Max	AC W					DC W			
BSP	mm			bar	AC bar	DC bar	$^{\circ}$ C	$^{\circ}$ C								
1/8"	1.8	1.5	110	0	-	8	-30	80	TPE/PVDF	131K0648	2161	495294	-	9	13.0	7872
	1.8	1.5	110	0	-	8	-30	80	TPE/PVDF	131K0648	2161	496193	-	9	13.0	7872



2 & 3 WAY  
VALVES FOR  
TRANSPORTATION

UK  
CA CE

For this page	Port size	Orifice (mm)	Qn (l/min)	MOPD (bar)	Fluid Temp (°C)
From	1/8"	1.8	110	8	-30
To	1/8"	1.8	110	8	80

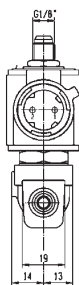
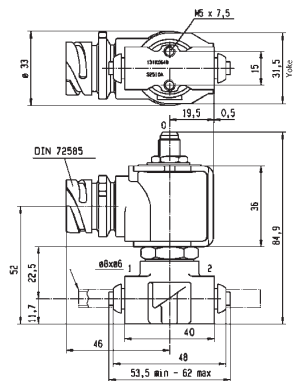

Drawing 7872



# 5 WAY DISTRIBUTORS FOR PNEUMATIC APPLICATIONS



## 5 WAY PNEUMATIC DISTRIBUTORS (PIPE MOUNTING/SUB-BASE MOUNTING)



# 5/2

Actuation	Body	Function	Port Size	Orifice (mm)	Qn (l/min)	MOPD (bar)	Max Fluid Temp. (°C)	Page Parker Valves
Pilot Operated	Anodized Aluminium/ Pipe Mounting	Normally Closed	1/8-1/4"	6	630	10	75	244
			1/4"	6 to 14	2500	40	75	244 and 246
			1/2"	14	2500	15	75	246
		Control by Electric Impulse	1/8-1/4"	6	630	10	75	248
			1/4"	8	1000	15	75	248
			1/2"	14	2500	15	75	248
	Anodized Aluminium/ Pipe Mounting/Poppet	Normally Closed	1/8"	4	400	10	75	250
			1/4"	8	1400	10	75	258
		Dual Solenoids	1/8"	4	315	10	75	258
			1/4"	8	1400	10	100	260
	Anodized Aluminium/ Sub-base Mounting	Normally Closed	SB	6	630	10	75	252
		Control by Electric Impulse	SB	6	630	10	75	252
	Anodized Aluminium/ Sub-base Mounting/ Poppet	Normally Closed	SB	4 to 15	5000	10	75	252
		Dual Solenoids	SB	4	400	10	75	254
Control by Electric Impulse		SB	15	5000	10	75	256	
Anodized Aluminium/ CETOP/Poppet POM/CETOP/Poppet	Dual Solenoids	SB	6	800	10	75	256	
	Normally Closed	SB	6	800	10	75	260	
		Control by Electric Impulse	SB	6	800	10	75	264
Externally Operated	Anodized Aluminium/ Sub-base Mounting	Normally Closed	SB	7	800	10	75	266

## 5 WAY VALVES

# 5/2

## 5 WAY PNEUMATIC DISTRIBUTORS (PIPE MOUNTING/SUB-BASE MOUNTING) PILOT OPERATED



Process



Industrial Equipment

### ANODIZED ALUMINIUM PIPE MOUNTING

#### SPRING RETURN

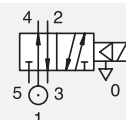
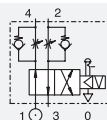

Port size BSP	Orifice Ø 1	Flow factor Qn l/min	Operating Pressure Differential			Fluid Temp.		Seat Seal	Valve Ref.	Housing Ref.	Coil Ref.	IS Power		Coil Group	Dwg. No.	
			Min bar	Max (MOPD) AC bar	DC bar	Min °C	Max °C					AC W	DC W			
1/4"	6	630	1	10	10	-10	75	NBR	341B34 <sub>3</sub>	4270	481000	8	8	2.0	3286	
	6	630	1	10	10	-10	75	NBR	341B34 <sub>3</sub>	2995	481865	8	9	2.0	3286	
	6	630	1	10	10	-10	75	NBR	341B34 <sub>3</sub>	4270	486265	14	14	2.0	3286	
	6	630	1	10	10	-10	75	NBR	341B3403 <sub>3</sub>	4270	481000	8	8	2.1	3286	
	6	630	1	10	10	-10	75	NBR	341B3403 <sub>4</sub>	2995	481865	8	9	2.1	3286	
	6	560	1	-	10	-10	55	NBR	341B3490	2995	48358001	*	-	0.5-3	6.0/7.0/8.0	3561
	6	560	1	-	10	-10	75	NBR	341B3490	-	495910	*	-	0.3-1.2	6.0/7.0/8.0	3561
	6	630	1	10	10	-25	75	PUR	341B3440 <sub>3</sub>	4270	481000	8	8	2.1	3286	
	6	630	1	10	10	-25	75	PUR	341B3440 <sub>3</sub>	2995	481865	8	9	2.1	3286	
	8	640	1	40	40	-10	75	NBR	341B02 <sub>2</sub>	4270	481000	8	8	2.1	8115	
8	640	1	40	40	-10	75	NBR	341B02 <sub>2</sub>	2995	481865	8	9	2.1	8115		

#### Notes:

1. Valve only compatible with air and neutral gases
2. Valve with pilot return pipe on exhaust port
3. With Flow regulator e manual override
4. With manual override



5 WAY VALVES



For this page	Port size	Orifice (mm)	Qn (l/min)	MOPD (bar)	Fluid Temp (°C)
From	1/8-1/4"	6	560	10	-25
To	1/4"	8	640	40	75

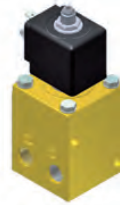
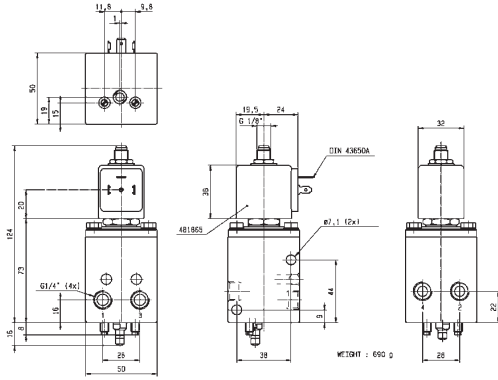

Drawing 3286

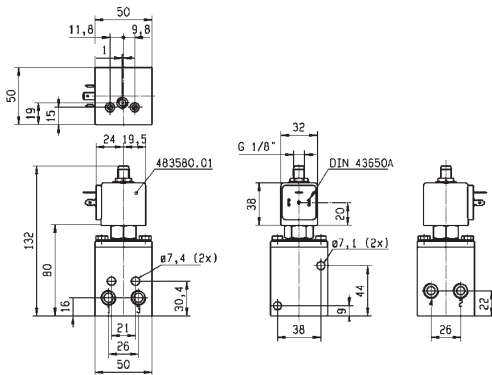

Drawing 3561

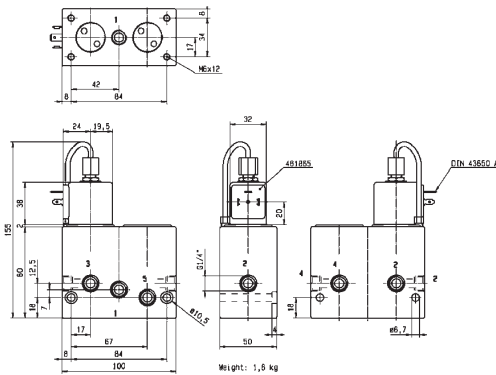

Drawing 8115



**5 WAY VALVES**

# 5/2

## 5 WAY PNEUMATIC DISTRIBUTORS (PIPE MOUNTING/SUB-BASE MOUNTING) PILOT OPERATED

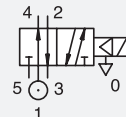
**ANODIZED ALUMINIUM**
**PIPE MOUNTING**
**SPRING RETURN**

Port size BSP	Orifice Ø 1 mm	Flow factor Qn l/min	Operating Pressure Differential			Fluid Temp.		Seat Seal	Valve Ref.	Housing Ref.	Coil Ref.	IS Power		Coil Group	Dwg. No.
			Min bar	Max (MOPD) AC bar DC bar	Min °C	Max °C	AC W					DC W			
1/4"	8	1000	1	15	15	-10	75	NBR	E341B01	2995	481865	8	9	2.1	3309
	8	1000	1	15	15	-10	75	NBR	E341B01	4270	485100	8	8	2.1	3309
	14	2500	2	15	15	-10	75	NBR	E341F21	4270	481000	8	8	2.1	3310
1/2"	14	2500	1	15	15	-10	75	NBR	E341B21 <sub>1</sub>	2995	481865	8	9	2.1	3315
	14	2500	1	15	15	-10	65	NBR	E341B21 <sub>1</sub>	-	483371	8	8	2.1	3315

**Notes:**

1. Valve only compatible with air and neutral gases
2. Valve with pilot return pipe on exhaust port
3. With Flow regulator e manual override
4. With manual override

### 5 WAY VALVES



For this page	Port size	Orifice (mm)	Qn (l/min)	MOPD (bar)	Fluid Temp (°C)
From	1/4"	8	1000	15	-10
To	1/2"	14	2500	15	75

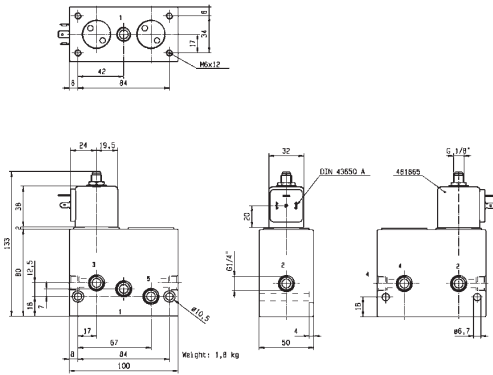

Drawing 3309

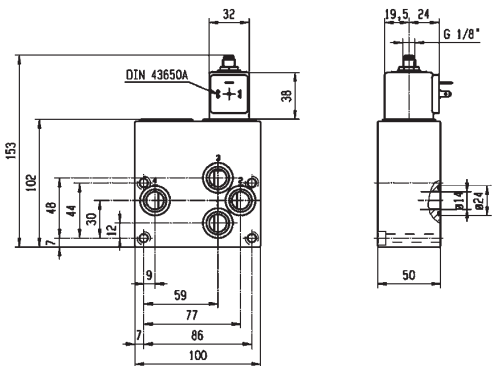

Drawing 3310

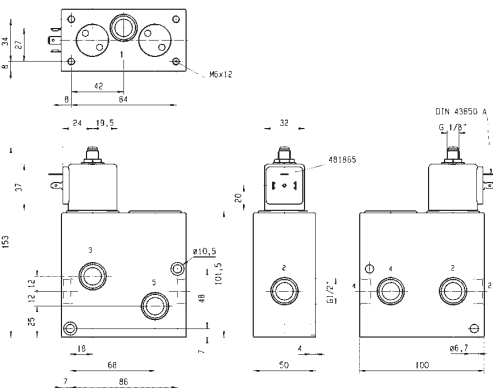

Drawing 3315



**5 WAY VALVES**

# 5/2

## 5 WAY PNEUMATIC DISTRIBUTORS (PIPE MOUNTING/SUB-BASE MOUNTING) PILOT OPERATED

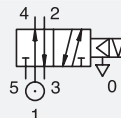
**ANODIZED ALUMINIUM  
PIPE MOUNTING**
**CONTROL BY ELECTRIC IMPULSE**

Port size BSP	Orifice Ø 1 mm	Flow factor Qn l/min	Operating Pressure Differential			Fluid Temp.		Seat Seal	Valve Ref.	Housing Ref.	Coil Ref.	Power		Coil Group	Dwg. No.
			Min bar	Max (MOPD) AC bar DC bar	Min °C	Max °C	AC W					DC W			
1/8- 1/4"	6	630	1	10	-	-10	75	NBR	345B34 <sub>12</sub>	4269	484990	11	-	4.0	3286
	6	630	1	-	10	-10	75	NBR	345B34 <sub>12</sub>	4269	485400	-	13	4.0	3286
1/4"	8	1000	1	15	-	-10	75	NBR	345B04	4269	484990	11	-	4.0	3309
	8	1000	1	-	15	-10	75	NBR	345B04	4269	485400	-	13	4.0	3309
1/2"	14	2500	1	15	-	-10	75	NBR	345B24	4269	484990	11	-	4.0	3315
	14	2500	1	-	15	-10	75	NBR	345B24	4269	485400	-	13	4.0	3315

**Notes:**

1. Valve only compatible with air and neutral gases
2. With flow regulator e manual override

## 5 WAY VALVES



For this page	Port size	Orifice (mm)	Qn (l/min)	MOPD (bar)	Fluid Temp (°C)
From	1/8-1/4"	6	630	10	-10
To	1/2"	14	2500	15	75

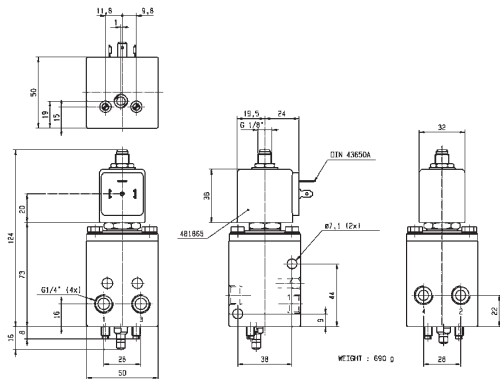

Drawing 3286

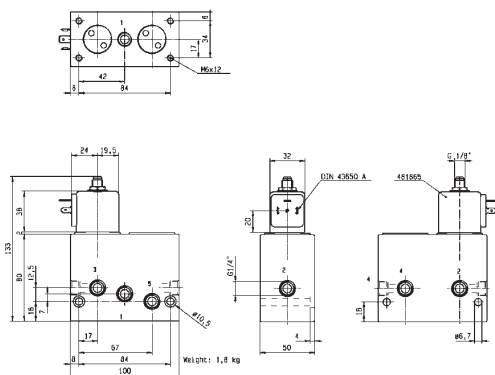

Drawing 3309

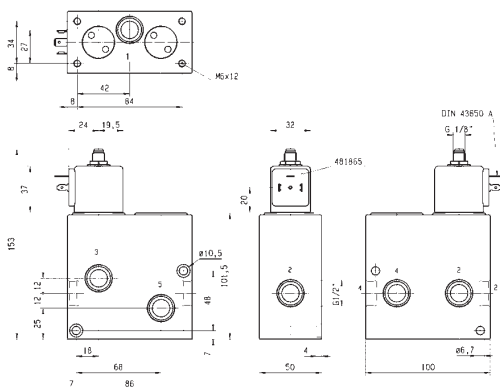

Drawing 3315



## 5 WAY VALVES

# 5/2

## 5 WAY PNEUMATIC DISTRIBUTORS (PIPE MOUNTING/SUB-BASE MOUNTING) PILOT OPERATED

### ANODIZED ALUMINIUM PIPE MOUNTING

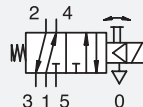

### SPRING RETURN

Port size	Orifice Ø	Flow factor	Operating Pressure Differential			Fluid Temp.		Seat Seal	Valve Ref.	Housing Ref.	Coil Ref.	Power		Coil Group	Dwg. No.
			Min	Max (MOPD)	DC	Min	Max					AC W	DC W		
1/8"	4	400	1	10	10	-10	65	NBR	341L9101 <sub>1</sub>	-	482605	4	5	1.1	3894
												2	2.5		
												2	2.5		
												2	2.5		

**Notes:**

1. With manual override

### ANODIZED ALUMINIUM PIPE MOUNTING

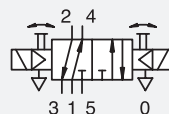

### DUAL SOLENOIDS

Port size	Orifice Ø	Flow factor	Operating Pressure Differential			Fluid Temp.		Seat Seal	Valve Ref.	Housing Ref.	Coil Ref.	Power		Coil Group	Dwg. No.
			Min	Max (MOPD)	DC	Min	Max					AC W	DC W		
1/8"	4	315	2	10	10	-10	65	NBR	347L9101 <sub>1</sub>	-	482605	4	5	1.1	3896
												2	2.5		
												2	2.5		
												2	2.5		

**Notes:**

1. With manual override

### 5 WAY VALVES



For this page	Port size	Orifice (mm)	Qn (l/min)	MOPD (bar)	Fluid Temp (°C)
From	1/8"	4	315	10	-10
To	1/8"	4	400	10	75

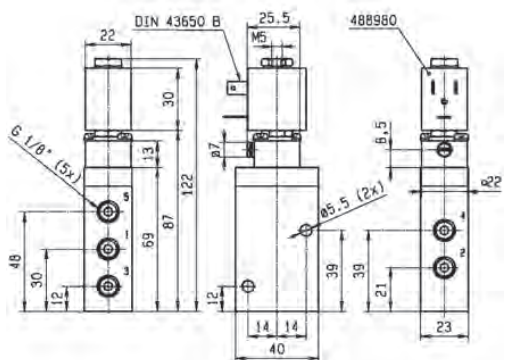

Drawing 3894

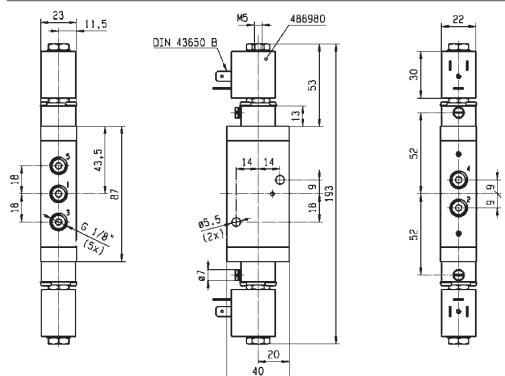

Drawing 3896



## 5 WAY VALVES

# 5/2

## 5 WAY PNEUMATIC DISTRIBUTORS (PIPE MOUNTING/SUB-BASE MOUNTING) PILOT OPERATED

### ANODIZED ALUMINIUM SUB-BASE MOUNTING

#### SPRING RETURN

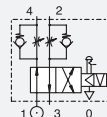

Port size	Orifice Ø 1	Flow factor Qn l/min	Operating Pressure Differential			Fluid Temp.		Seat Seal	Valve Ref.	Housing Ref.	Coil Ref.	Power		Coil Group	Dwg. No.
			Min bar	Max (MOPD) AC bar	DC bar	Min °C	Max °C					AC W	DC W		
SB	6	630	1	10	10	-10	75	NBR	341F34 <sub>12</sub>	2995	481865	8	9	2.1	3287
	6	630	1	10	10	-10	75	NBR	341F34 <sub>12</sub>	4270	481000	8	8	2.1	3287
	6	630	1	10	10	-10	75	NBR	341F3403 <sub>2</sub>	2995	481865	8	9	2.1	3287
	6	630	1	10	10	-10	75	NBR	341F3403 <sub>2</sub>	4270	481000	8	8	2.1	3287
	6	630	1	10	10	-25	75	NBR	341F3440 <sub>12</sub>	2995	481865	8	9	2.1	3287

Notes:

1. With flow regulator
2. With manual override

### ANODIZED ALUMINIUM SUB-BASE MOUNTING

#### CONTROL BY ELECTRIC IMPULSE

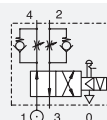

Port size	Orifice Ø 1	Flow factor Qn l/min	Operating Pressure Differential			Fluid Temp.		Seat Seal	Valve Ref.	Housing Ref.	Coil Ref.	Power		Coil Group	Dwg. No.
			Min bar	Max (MOPD) AC bar	DC bar	Min °C	Max °C					AC W	DC W		
SB	6	630	1	10	-	-10	75	NBR	345F34 <sub>1</sub>	4269	484990	11	-	4.0	3287
	6	630	1	-	10	-10	75	NBR	345F34 <sub>1</sub>	4269	485400	-	13	4.0	3287

Notes:

1. With flow regulator e manual override

## 5 WAY VALVES



For this page	Port size	Orifice (mm)	Qn (l/min)	MOPD (bar)	Fluid Temp (°C)
From	SB	6	630	10	-25
To	SB	6	630	10	75

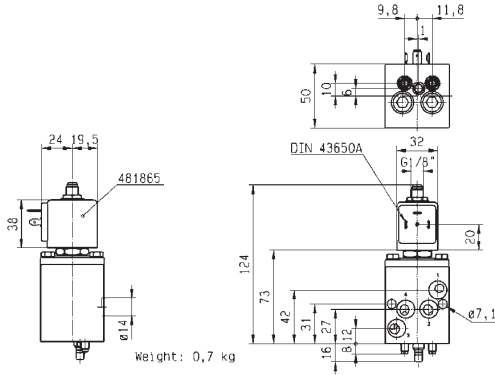

Drawing 3287

## 5 WAY VALVES

# 5/2

## 5 WAY PNEUMATIC DISTRIBUTORS (PIPE MOUNTING/SUB-BASE MOUNTING) PILOT OPERATED

### ANODIZED ALUMINIUM SUB-BASE MOUNTING

#### SPRING RETURN

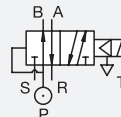

Port size	Orifice Ø 1 mm	Flow factor Qn l/min	Operating Pressure Differential			Fluid Temp.		Seat Seal	Valve Ref.	Housing Ref.	Coil Ref.	Power		Coil Group	Dwg. No.
			Min bar	Max (MOPD) AC bar	DC bar	Min °C	Max °C					AC W	DC W		
SB	15	5000	0.5	10	10	-10	75	FKM	E341L21	2995	481865	8	9	2.1/3.0	3299
	15	5000	0.5	10	10	-10	75	FKM	E341L21	-	495905	8	8	2.1/3.0	3299
SB	15	5000	0.5	-	10	-10	55	NBR	341L2190	2995	48358001	*	- 0.5-3	6.0/7.0/8.0	8271
	15	5000	0.5	-	10	-10	75	NBR	341L2190	-	495910	*	- 0.3-1.2	6.0/7.0/8.0	8271
SB	4	400	1	10	10	-10	65	NBR	341L9201	-	482605	4	5	1.1	3895
	4	400	1	10	10	-10	65	NBR	341L9201	-	482606	2	2.5	1.1	3895
	4	400	1	10	10	-10	75	NBR	341L9201	8993	488980	2	2.5	1.1	3895
	4	400	1	10	10	-10	50	NBR	341L9201	8993	495865	2	2.5	1.1	3895

### ANODIZED ALUMINIUM SUB-BASE MOUNTING

#### NORMALLY CLOSED

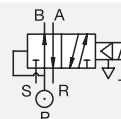

Port size	Orifice Ø 1 mm	Flow factor Qn l/min	Operating Pressure Differential			Fluid Temp.		Seat Seal	Valve Ref.	Housing Ref.	Coil Ref.	Power		Coil Group	Dwg. No.
			Min bar	Max (MOPD) AC bar	DC bar	Min °C	Max °C					AC W	DC W		
SB	4	400	1	10	10	-10	75	NBR	341L9201	-	482605	-	5	1.1	3895
	4	400	1	10	10	-10	75	NBR	341L9201	-	482606	2	2.5	1.1	3895
	4	400	1	10	10	-10	75	NBR	341L9201	8993	488980	2	2.5	1.1	3895
	4	400	1	10	10	-10	75	NBR	341L9201	8993	495865	2	2.5	1.1	3895

**Notes:**

1. With manual override

### 5 WAY VALVES



For this page	Port size	Orifice (mm)	Qn (l/min)	MOPD (bar)	Fluid Temp (°C)
From	SB	4	400	10	-10
To	SB	15	5000	10	75

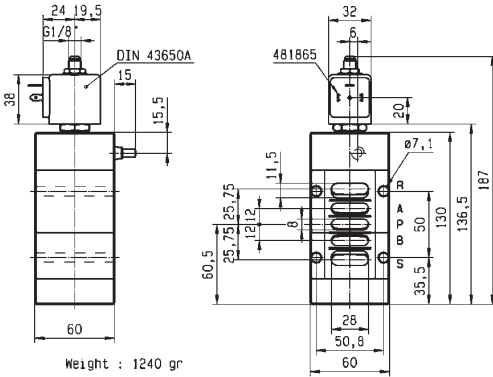

Drawing 3299

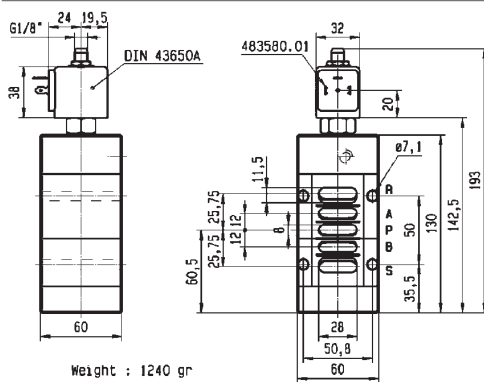

Drawing 8271

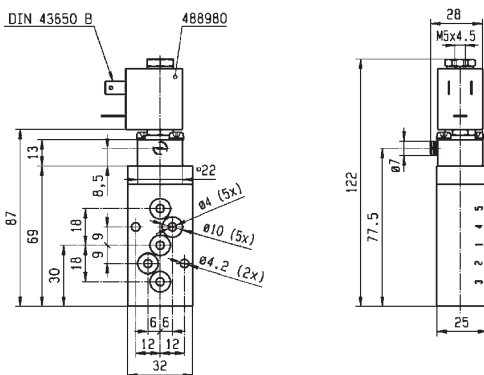

Drawing 3895



**5 WAY VALVES**

# 5/2

## 5 WAY PNEUMATIC DISTRIBUTORS (PIPE MOUNTING/SUB-BASE MOUNTING) PILOT OPERATED

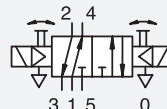
**ANODIZED ALUMINIUM  
SUB-BASE MOUNTING**
**DUAL SOLENOIDS**

Port size	Orifice Ø 1	Flow factor Qn l/min	Operating Pressure Differential			Fluid Temp.		Seat Seal	Valve Ref.	Housing Ref.	Coil Ref.	Power		Coil Group	Dwg. No.
			Min bar	Max (MOPD) AC bar	DC bar	Min °C	Max °C					AC W	DC W		
SB	4	315	2	10	10	-10	65	NBR	347L9201	-	482605	4	5	1.1	3897
	4	315	2	10	10	-10	65	NBR	347L9201	-	482606	2	2.5	1.1	3897
	4	315	2	10	10	-10	75	NBR	347L9201	8993	488980	2	2.5	1.1	3897
	4	315	2	10	10	-10	50	NBR	347L9201	8993	495865	2	2.5	1.1	3897

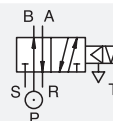
**ANODIZED ALUMINIUM  
SUB-BASE MOUNTING**
**CONTROL BY ELECTRIC IMPULSE**

Port size	Orifice Ø 1	Flow factor Qn l/min	Operating Pressure Differential			Fluid Temp.		Seat Seal	Valve Ref.	Housing Ref.	Coil Ref.	Power		Coil Group	Dwg. No.
			Min bar	Max (MOPD) AC bar	DC bar	Min °C	Max °C					AC W	DC W		
SB	15	5000	0.5	10	-	-10	75	NBR	345L21	4269	484990	11	-	4.0	3299
	15	5000	0.5	-	10	-10	75	NBR	345L21	4269	485400	-	13	4.0	3299

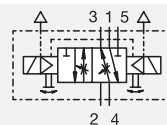
**ANODIZED ALUMINIUM  
CETOP**
**DUAL SOLENOIDS**

Port size	Orifice Ø 1	Flow factor Qn l/min	Operating Pressure Differential			Fluid Temp.		Seat Seal	Valve Ref.	Housing Ref.	Coil Ref.	Power		Coil Group	Dwg. No.
			Min bar	Max (MOPD) AC bar	DC bar	Min °C	Max °C					AC W	DC W		
SB	6	800	1	10	10	-10	75	NBR	347L04	8993	488980	2	2.5	1.1	3694



**5 WAY VALVES**

# 5/2

## 5 WAY PNEUMATIC DISTRIBUTORS (PIPE MOUNTING/SUB-BASE MOUNTING) PILOT OPERATED

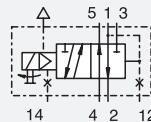
**ANODIZED ALUMINIUM  
PIPE MOUNTING**
**SPRING RETURN**

Port size	Orifice Ø	Flow factor	Operating Pressure Differential			Fluid Temp.		Seat Seal	Valve Ref.	Housing Ref.	Coil Ref.	Power		Coil Group	Dwg. No.
			Min	Max (MOPD)	DC bar	Min	Max					AC W	DC W		
BSP	mm	Qn l/min	bar	AC bar	DC bar	°C	°C								
1/4"	8	1400	1	10	10	-10	75	NBR	341L11	8993	488980	2	2.5	1.1	3434
	8	1400	1	10	10	-10	50	NBR	341L11	8993	495865	2	2.5	1.1	3434
	8	1400	1	10	10	-10	65	NBR	341L11	-	482605	4	5	1.1	3434
	8	1400	1	10	10	-10	65	NBR	341L11	-	482606	2	2.5	1.1	3434
	8	1400	1	10	10	-10	75	NBR	E341L1130	2995	481865	8	9	2.1/3.0	3539
	8	1400	1	10	10	-10	65	NBR	E341L1130	-	483371	8	8	2.1/3.0	3539
1/4" NPT	8	1400	1	10	10	-10	75	FKM	U341L1130	2995	481865	8	9	2.1	8297
	8	1400	1	10	10	-10	75	FKM	U341L1130	2995	491514	11	12	2.1	8297



## 5 WAY VALVES

IECEX certified

UK CA

For this page	Port size	Orifice (mm)	Qn (l/min)	MOPD (bar)	Fluid Temp (°C)
From	1/4"	8	1400	10	-10
To	1/4"	8	1400	10	75

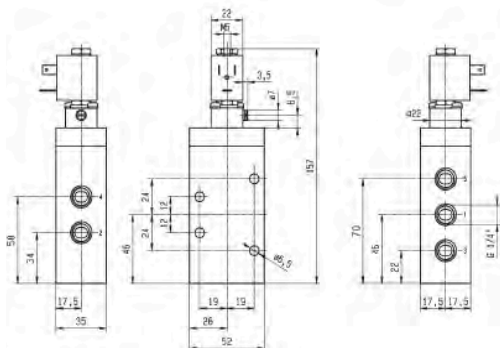

Drawing 3434

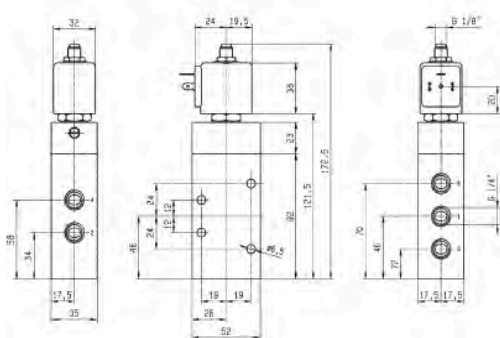

Drawing 3539

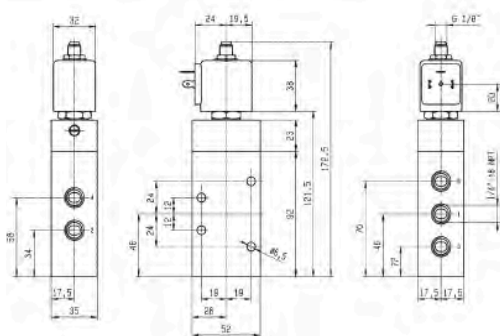

Drawing 8297



## 5 WAY VALVES

# 5/2

## 5 WAY PNEUMATIC DISTRIBUTORS (PIPE MOUNTING/SUB-BASE MOUNTING) PILOT OPERATED

### ANODIZED ALUMINIUM PIPE MOUNTING

#### DUAL SOLENOIDS

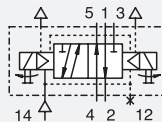

Port size	Orifice Ø	Flow factor	Operating Pressure Differential			Fluid Temp.		Seat Seal	Valve Ref.	Housing Ref.	Coil Ref.	Power		Coil Group	Dwg. No.
			Min	Max (MOPD)	DC bar	Min	Max					AC W	DC W		
1/4"	8	1400	1	10	10	-10	65	NBR	347L11 <sub>1</sub>	-	482605	4	5	1.1	3461
	8	1400	1	10	10	-10	65	NBR	347L11 <sub>1</sub>	-	482606	2	2.5	1.1	3461
	8	1400	1	10	10	-10	75	NBR	347L11 <sub>1</sub>	8993	488980	2	2.5	1.1	3461
	8	1400	1	10	10	-10	50	NBR	347L11 <sub>1</sub>	8993	495865	2	2.5	1.1	3461
	8	1400	2	10	10	-10	100	FKM	E347L1130 <sub>1</sub>	2995	481865	8	9	2.1/3.0	3541
	8	1400	2	10	10	-10	100	FKM	E347L1130 <sub>1</sub>	4270	481000	8	8	2.1/3.0	3541

Notes:

1. With manual override

### POM CETOP

#### SPRING RETURN

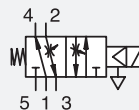

Port size	Orifice Ø	Flow factor	Operating Pressure Differential			Fluid Temp.		Seat Seal	Valve Ref.	Housing Ref.	Coil Ref.	IS	Power		Coil Group	Dwg. No.
			Min	Max (MOPD)	DC bar	Min	Max						AC W	DC W		
SB	6	800	1	10	10	-10	75	FKM	E341L02	2995	481865		8	9	2.1/3.0	3513
	6	800	1	10	10	-10	75	FKM	E341L02	4270	481000		8	8	2.1/3.0	3513

Notes:

1. Manual override and flow regulating screws standard

2. With manual override

## 5 WAY VALVES

IECEX  
certified



UK  
CA



For this page	Port size	Orifice (mm)	Qn (l/min)	MOPD (bar)	Fluid Temp (°C)
From	1/4"	6	800	10	-10
To	1/4"	8	1400	10	100

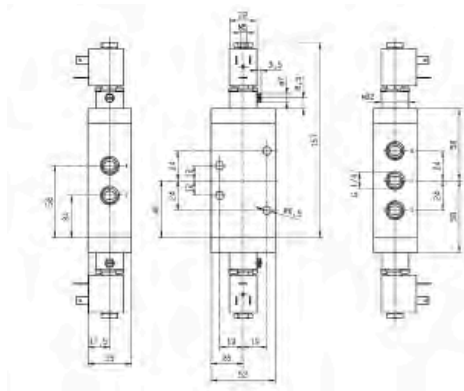

Drawing 3461

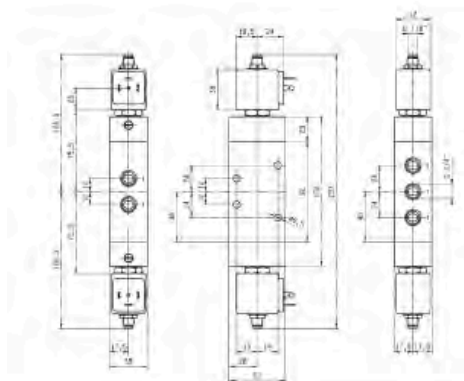

Drawing 3541

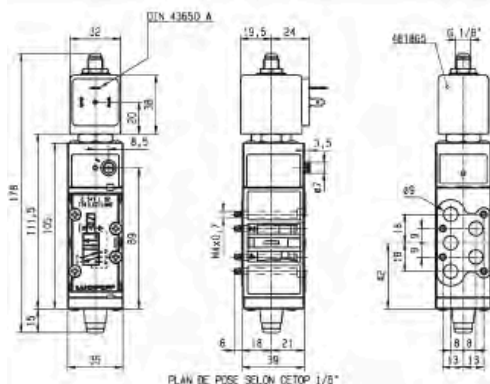

Drawing 3513

# 5 WAY VALVES

# 5/2

## 5 WAY PNEUMATIC DISTRIBUTORS (PIPE MOUNTING/SUB-BASE MOUNTING) PILOT OPERATED

POM

CETOP

SPRING RETURN

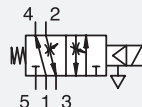

Port size	Orifice Ø	Flow factor	Operating Pressure Differential			Fluid Temp.		Seat Seal	Valve Ref.	Housing Ref.	Coil Ref.	IS Power		Coil Group	Dwg. No.
			Min	Max (MOPD)	DC bar	Min	Max					AC W	DC W		
SB	8	800	1	10	10	-10	65	FKM	341L04 <sub>1</sub>	-	482605	4	5	1.1	3437
	8	800	1	10	10	-10	65	FKM	341L04 <sub>1</sub>	-	482606	2	2.5	1.1	3437
	8	800	1	10	10	-10	75	FKM	341L04 <sub>1</sub>	8993	488980	2	2.5	1.1	3437
	8	800	1	10	10	-10	50	FKM	341L04 <sub>1</sub>	8993	495865	2	2.5	1.1	3437
SB	6	800	1	-	10	-10	75	NBR	341L0197	2995	482740	-	1.6	6.0/8.0	8021
	6	800	1	10	10	-10	75	NBR	341L0197	-	495900	2.5	2	6.0/8.0	8021
	6	800	1	-	10	-10	75	NBR	341L0197	-	495910	* -	0.3-1.2	6.0/8.0	8021
	6	800	1	-	10	-10	65	NBR	341L0197	2995	496125	-	1.6	6.0/8.0	8021
	6	800	1	10	10	-10	65	NBR	341L05 <sub>2</sub>	-	482605	4	5	1.1	3430
	6	800	1	10	10	-10	65	NBR	341L05 <sub>2</sub>	-	482606	2	2.5	1.1	3430
	6	800	1	10	10	-10	75	NBR	341L05 <sub>2</sub>	8993	488980	2	2.5	1.1	3430
	6	800	1	10	10	-10	50	NBR	341L05 <sub>2</sub>	8993	495865	2	2.5	1.1	3430
	6	800	1	10	-	-10	75	FKM	E341L01 <sub>1</sub>	2995	482722	10	-	2.1/3.0	3255
	6	800	1	10	10	-10	65	FKM	E341L01 <sub>1</sub>	-	483371	8	8	2.1/3.0	3255
	6	800	1	10	10	-10	75	FKM	E341L01 <sub>1</sub>	299533	491514	11	12	2.1/3.0	3255

**Notes:**

1. Manual override and flow regulating screws standard
2. With manual override

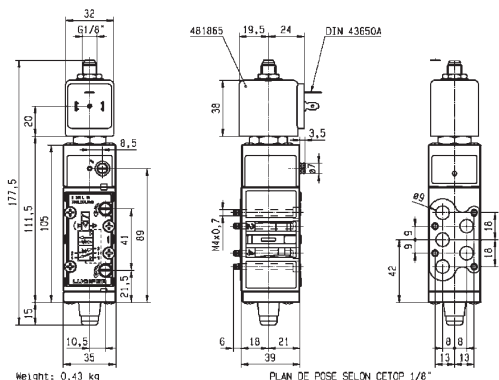

Drawing 3255



### 5 WAY VALVES



For this page	Port size	Orifice (mm)	Qn (l/min)	MOPD (bar)	Fluid Temp (°C)
From	SB	6	800	10	-10
To	SB	8	800	10	75

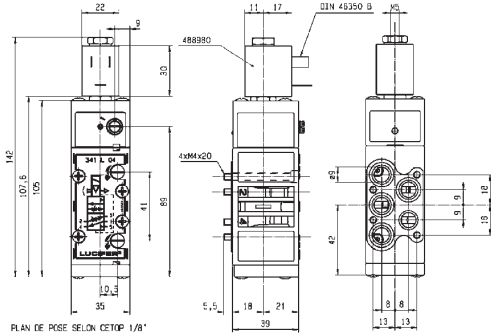

PLAN DE POSE SELON CÉTOP 1/8"



Drawing 3437

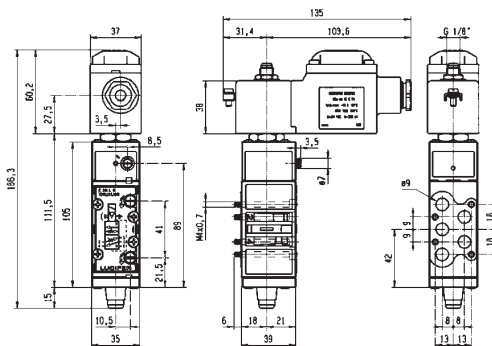

Drawing 8021

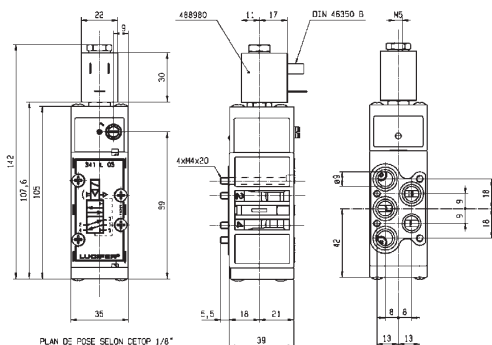

PLAN DE POSE SELON CÉTOP 1/8"



Drawing 3430



5 WAY VALVES

# 5/2

## 5 WAY PNEUMATIC DISTRIBUTORS (PIPE MOUNTING/SUB-BASE MOUNTING) PILOT OPERATED

POM

CETOP

### CONTROL BY ELECTRIC IMPULSE

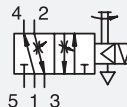

Port size BSP	Orifice Ø mm	Flow factor Qn l/min	Operating Pressure Differential			Fluid Temp.		Seat Seal	Valve Ref.	Housing Ref.	Coil Ref.	Power		Coil Group	Dwg. No.
			Min bar	Max (MOPD) AC bar DC bar	Min °C	Max °C	AC W					DC W			
SB	6	800	1	- 10	-10 75	FKM	345L01	4269	485400	- 13	4.0	3255			

Notes:

1. Manual override and flow regulating screws standard



### 5 WAY VALVES



For this page	Port size	Orifice (mm)	Qn (l/min)	MOPD (bar)	Fluid Temp (°C)
From	SB	6	800	10	-10
To	SB	6	800	10	75

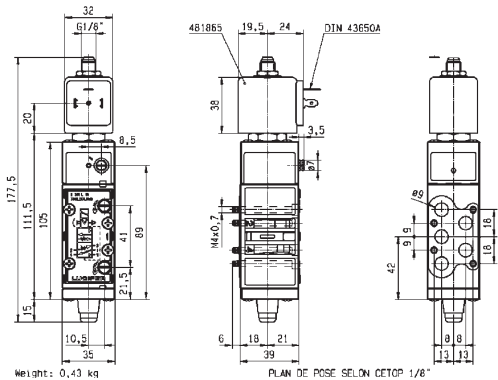

Drawing 3255



5 WAY VALVES

# 5/2

## 5 WAY PNEUMATIC DISTRIBUTORS (PIPE MOUNTING/SUB-BASE MOUNTING) EXTERNALLY OPERATED



Process



Industrial Equipment

### ANODIZED ALUMINIUM SUB-BASE MOUNTING

#### SPRING RETURN

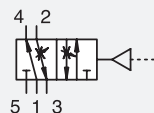

Port size	Orifice Ø mm	Flow factor Qn l/min	Operating Pressure Differential			Fluid Temp.		Seat Seal FKM/ NBR	Valve Ref.	Housing Ref.	Coil Ref.	Power		Coil Group	Dwg. No.
			Min bar	Max (MOPD) AC bar DC bar	Min °C	Max °C	AC W					DC W			
SB	7	800	1	10 10	10	-10	75	FKM/ NBR	541L01	-	-	-	-	-	3254



### 5 WAY VALVES



For this page	Port size	Orifice (mm)	Qn (l/min)	MOPD (bar)	Fluid Temp (°C)
From	SB	7	800	10	-10
To	SB	7	800	10	75

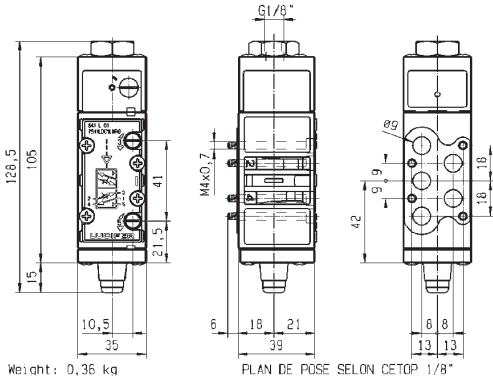

Weight: 0,36 kg

PLAN DE POSE SELON CETOP 1/8"



Drawing 3254



## 3 & 5 WAY PNEUMATIC DISTRIBUTORS FOR ACTUATION CONTROL



### 3 & 5 WAY PNEUMATIC VALVES FOR ACTUATOR CONTROL (PIPE MOUNTING)



**3/2**  
**5/2**

Actuation	Body	Function	Port Size	Orifice (mm)	Qn (l/min)	MOPD (bar)	Max Fluid Temp. (°C)	Page Parker Valves
Direct Operated	Brass/Pipe mounting	Normally Closed	1/8"	1.2 to 1.5	70	10	75	276
			1/8"-1/4"	2.5	220	7	75	276
			1/4"	1	36	10	120	276
	Brass/Sub-base mounting	Normally Open/Universal	1/4"	2.5 - 6	680	7-10	75	282
			Control by Electric Impulse	1/4"	2.5	220	7	100
		Normally Closed	5 mm	2.5	180	2	75	286
			Universal	1/8"	2	140	7	120
Anodized aluminium/ Pipe mounting	Universal	1/4"	6	680	10	75	288	
Pilot Operated	Anodized aluminium/ Pipe mounting/Spool	Normally Closed	1/8"	4 to 15	600	10	80	290
			1/4"	7 to 8	1400	10	80	292
			1/2"	12	3000	10	50	296
		Dual Solenoids	1/8"	4	400	10	80	298
			1/4"	7 to 8	1400	10	80	300
			1/2"	12	3000	10	50	302
	Control by Electric Impulse	1/8"	4	600	10	80	302	
Manual Reset	Brass/Pipe mounting	Universal	1/4"	6	680	10	65	302

### 3 & 5 WAY PNEUMATIC DISTRIBUTORS

# 3/2

## 3 & 5 WAY PNEUMATIC VALVES FOR ACTUATOR CONTROL (PIPE MOUNTING) DIRECT OPERATED

### BRASS

### PIPE MOUNTING

### NORMALLY CLOSED

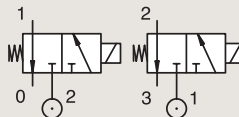

Port size	Orifice Ø	Flow factor	Operating Pressure Differential			Fluid Temp.		Seat Seal	Valve Ref.	Housing Ref.	Coil Ref.	ATEX Zone	Protection Mode	Power		Coil Group	Dwg. No.
			Min	Max (MOPD)	AC	DC	Min							Max	AC W		
1/8"	1.2	50	0	10	10	-10	75	FKM	131M15	8993	488980	-	-	2	2.5	1.1	3382
	1.2	50	0	10	10	-10	75	FKM	131M1550	8993	488980	-	-	2	2.5	1.1	3382
	1.5	70	0	7	7	-10	75	FKM	131M14	8993	488980	-	-	2	2.5	1.1	3382
1/8"-1/4"	2.5	220	0	7	7	-40	75	PUR	E131K0358	2995	481865	-	-	8	9	2.1	3510
	2.5	220	0	7	7	-40	75	PUR	E131K0358	4270	481000	-	-	8	8	2.1	3510
1/4"	1	36	0	-	10	-10	55	FKM	131K0490	2995	483580.01	0-20	Ex ia IIC T6	-	0.5 to 3	7.0	7058
	1	36	0	-	10	-10	75	FKM	131K0490	-	488660.01	0-20	Ex ia IIC T6	-	0.3 to 3	7.0	7058
	1	36	0	-	10	-10	75	FKM	131K0490	-	495910	0-20	Ex ia IIC T4 to T6	-	0.3 to 3	7.0	7058

**Notes:**

1. With manual override



### 3 & 5 WAY PNEUMATIC DISTRIBUTORS



For this page	Port size	Orifice (mm)	Qn (l/min)	MOPD (bar)	Fluid Temp (°C)
From	1/8"	1	36	7	-40
To	1/4"	2.5	220	10	75

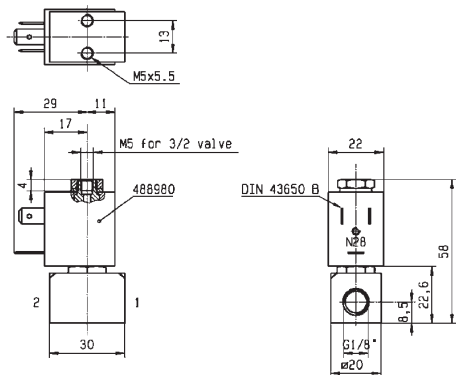

Drawing 3382

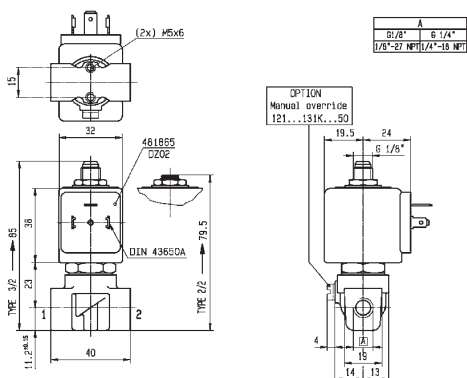

Drawing 3510

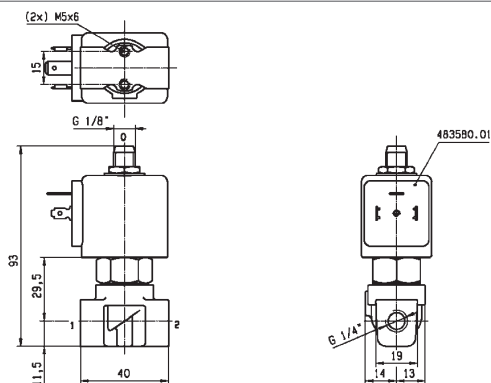

Drawing 7058



### 3 & 5 WAY PNEUMATIC DISTRIBUTORS

# 3/2

## 3 & 5 WAY PNEUMATIC VALVES FOR ACTUATOR CONTROL (PIPE MOUNTING) DIRECT OPERATED

### BRASS

### PIPE MOUNTING

### NORMALLY CLOSED

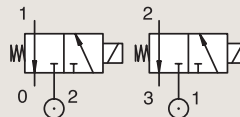

Port size	Orifice Ø	Flow factor	Operating Pressure Differential			Fluid Temp.		Seat Seal	Valve Ref.	Housing Ref.	Coil Ref.	ATEX Zone	Protection Mode	Power		Coil Group	Dwg. No.
			Min	Max (MOPD)	Max	Min	Max							AC W	DC W		
BSP	mm	Qn l/min	bar	AC bar	DC bar	°C	°C										
1/4"	1.5	80	0	-	7	-20	75	PUR	131K0497	2995	482740	-	-	-	1.6	6.0/8.0	8023
	1.5	80	0	7	7	-20	75	PUR	131K0497	-	495900	1-21	Ex d mb IIC T4 to T6	2.5	2	6.0/8.0	8023
	1.5	80	0	-	7	-20	75	PUR	131K0497	-	495910	0-20	Ex ia IIC T4 to T6	-	0.3 to 3	6.0/8.0	8023
	1.5	80	0	-	7	-20	75	PUR	131K0497	2995	496125	2-22	Ex nAC IIC T5/T6	-	1.6	6.0/8.0	8023
	1.5	80	0	16	16	-10	100	FKM	E131K04	2995	481865	-	-	8	9	2.0	3510
	1.5	80	0	16	16	-10	120	FKM	E131K04	4270	481000	-	-	8	8	2.0	3510
	1.5	80	0	16	16	-10	120	FKM	E131K04	4270	486265	-	-	14	14	2.0	3510
	1.5	80	0	15	15	-10	100	FKM	E131K0450	2995	481865	-	-	8	9	2.1	3510
	1.5	80	0	15	15	-10	120	FKM	E131K0450	4270	481000	-	-	8	8	2.1	3510
	2	140	0	10	10	-10	100	FKM	E131K06	2995	481865	-	-	8	9	2.0	8119
	2	140	0	10	10	-10	120	FKM	E131K06	4270	481000	-	-	8	8	2.0	8119
	2	140	0	10	10	-10	120	FKM	E131K06	4270	486265	-	-	14	14	2.0	8119
	2	140	0	10	10	-10	100	FKM	E131K0650	2995	481865	-	-	8	9	2.1	3510
	2	140	0	10	10	-10	120	FKM	E131K0650	4270	481000	-	-	8	8	2.1	3510

#### Notes:

1. With manual override



### 3 & 5 WAY PNEUMATIC DISTRIBUTORS



For this page	Port size	Orifice (mm)	Qn (l/min)	MOPD (bar)	Fluid Temp (°C)
From	1/4"	1.5	80	7	-20
To	1/4"	2	140	16	120

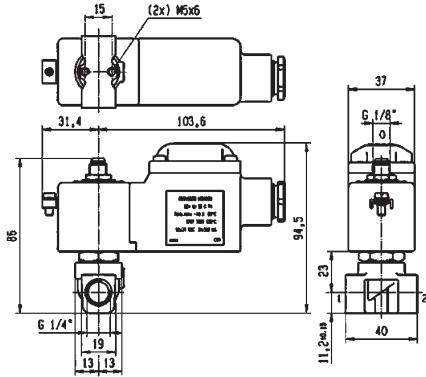

Drawing 8023

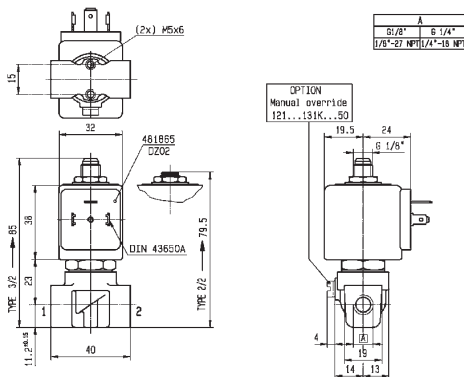

Drawing 3510

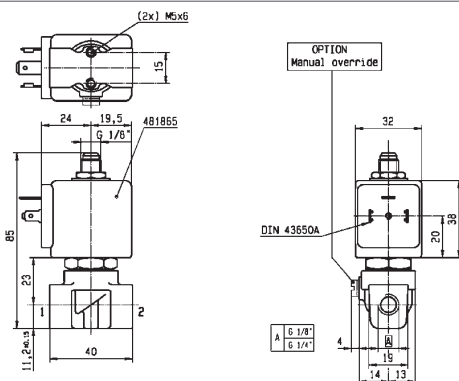

Drawing 8119

### 3 & 5 WAY PNEUMATIC DISTRIBUTORS

# 3/2

## 3 & 5 WAY PNEUMATIC VALVES FOR ACTUATOR CONTROL (PIPE MOUNTING) DIRECT OPERATED

### BRASS

### PIPE MOUNTING

### NORMALLY CLOSED

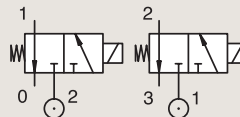

Port size	Orifice Ø	Flow factor	Operating Pressure Differential			Fluid Temp.		Seat Seal	Valve Ref.	Housing Ref.	Coil Ref.	ATEX Zone	Protection Mode	Power		Coil Group	Dwg. No.
			Min	Max (MOPD)	AC bar	DC bar	Min °C							Max °C	AC W		
1/4"	2.5	220	0.1	7	7	-10	75	FKM	E131E03	2995	481865	-	-	8	9	2.0	3525
	2.5	220	0.1	7	7	-10	75	FKM	E131E03	4270	481000	-	-	8	8	2.0	3525
	2.5	220	0.1	7	7	-10	75	FKM	E131E03	4270	486265	-	-	14	14	2.0	3525
	2.5	220	0	7	7	-40	75	PUR	E131K0308	2995	481865	-	-	8	9	2.1	3510
	2.5	220	0	7	7	-40	75	PUR	E131K0308	4270	481000	-	-	8	8	2.1	3510
	2.5	220	0	7	7	-10	100	FKM	E131K0350 <sub>1</sub>	2995	481865	-	-	8	9	2.1	3510
	2.5	220	0	7	7	-10	120	FKM	E131K0350 <sub>1</sub>	4270	481000	-	-	8	8	2.1	3510
	4.5	500	0	2	2	-10	75	FKM	131T2101 <sub>1</sub>	2995	481865	-	-	8	9	2.1	3223
4.5	500	0	2	2	-10	75	FKM	131T2101 <sub>1</sub>	4270	481000	-	-	8	8	2.1	3223	

Notes:

1. With manual override





### 3 & 5 WAY PNEUMATIC DISTRIBUTORS

# 3/2

## 3 & 5 WAY PNEUMATIC VALVES FOR ACTUATOR CONTROL (PIPE MOUNTING) DIRECT OPERATED

### BRASS

#### PIPE MOUNTING

#### NORMALLY OPEN

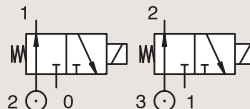

Port size	Orifice Ø	Flow factor	Operating Pressure Differential			Fluid Temp.		Seat Seal	Valve Ref.	Housing Ref.	Coil Ref.	ATEX Zone	Protection Mode	Power		Coil Group	Dwg. No.
			Min	Max (MOPD)	Min	Max	AC W							DC W			
BSP	mm	Qn l/min	bar	AC bar	DC bar	°C	°C										
	1																
	2.5	220	0	7	3.5	-10	75	FKM	132T29	2995	481865	-	-	8	9	2.0	3223
1/4"	2.5	220	0	7	3.5	-10	75	FKM	132T29	4270	481000	-	-	8	8	2.0	3223
	2.5	220	0	-	7	-10	75	FKM	132T29	4270	486265	-	-	-	14	2.0	3223

### BRASS

#### PIPE MOUNTING

#### UNIVERSAL

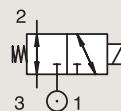

Port size	Orifice Ø	Flow factor	Operating Pressure Differential			Fluid Temp.		Seat Seal	Valve Ref.	Housing Ref.	Coil Ref.	ATEX Zone	Protection Mode	Power		Coil Group	Dwg. No.
			Min	Max (MOPD)	Min	Max	AC W							DC W			
BSP	mm	Qn l/min	bar	AC bar	DC bar	°C	°C										
	1																
1/4"	6	680	0	12	12	-25	65	NBR	U133X0111	-	492310	1-21	Ex e mb II T3 to T6	6	6	9.0/10.1/10.2	7422
NPT	6	680	0	-	12	-25	75	NBR	U133X0111	-	492965.01	0-20	Ex ia IIC T6	-	0.3 to 3	9.0/10.1/10.2	7422

Notes:

1. DC voltage only. Minimum drop off voltage is 15% of nominal voltage (former DIN 19251)



**3 & 5 WAY  
PNEUMATIC  
DISTRIBUTORS**

# 3/2

**3 & 5 WAY PNEUMATIC VALVES  
FOR ACTUATOR CONTROL (PIPE MOUNTING)  
DIRECT OPERATED**

**BRASS**

**PIPE MOUNTING**

**CONTROL BY ELECTRIC IMPULSE**

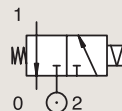

Port size	Orifice Ø	Flow factor	Operating Pressure Differential			Fluid Temp.		Seat Seal	Valve Ref.	Housing Ref.	Coil Ref.	ATEX Zone	Protection Mode	Power		Coil Group	Dwg. No.
			Min	Max (MOPD)	DC bar	Min	Max							AC W	DC W		
BSP	1	Qn l/min	bar	AC bar	DC bar	°C	°C										
1/4"	2.5	220	0	-	7	-10	100	FKM	135K03	4269	485400	-	-	-	13	4.0	3510



### 3 & 5 WAY PNEUMATIC DISTRIBUTORS



IECEX certified **Ex EAC**

For this page	Port size	Orifice (mm)	Qn (l/min)	MOPD (bar)	Fluid Temp (°C)
From	1/4"	2.5	220	7	-25
To	1/4"	2.5	220	7	100

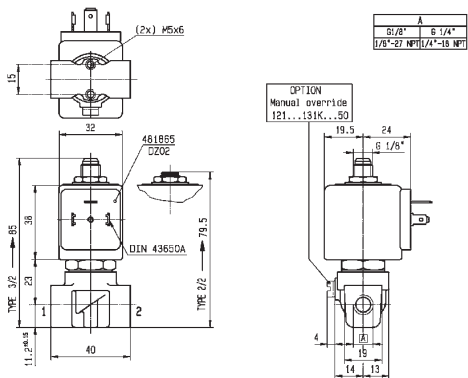

Drawing 3510

### 3 & 5 WAY PNEUMATIC DISTRIBUTORS

# 3/2

## 3 & 5 WAY PNEUMATIC VALVES FOR ACTUATOR CONTROL (PIPE MOUNTING) DIRECT OPERATED

### BRASS

#### SUB-BASE MOUNTING

#### NORMALLY CLOSED

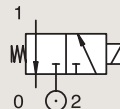

Port size	Orifice Ø 1 mm	Flow factor Qn l/min	Operating Pressure Differential			Fluid Temp.		Seat Seal	Valve Ref.	Housing Ref.	Coil Ref.	ATEX Zone	Protection Mode	Power		Coil Group	Dwg. No.
			Min	Max (MOPD) AC bar DC bar	Min	Max	AC W							DC W			
SB	2.5	180	0	-	2	-20	75	PUR	131F4397	2995	482740	-	-	-	1.6	6.0/8.0	8022
	2.5	180	0	2	2	-20	75	PUR	131F4397	-	495900	1-21	Ex d mb IIC T4 to T6	2.5	2	6.0/8.0	8022
	2.5	180	0	-	2	-20	75	PUR	131F4397	-	495910	0-20	Ex ia IIC T4 to T6	-	0.3 to 3	6.0/8.0	8022
	2.5	180	0	-	2	-20	75	PUR	131F4397	2995	496125	2-22	Ex nAC IIC T5/T6	-	1.6	6.0/8.0	8022

### BRASS

#### SUB-BASE MOUNTING

#### UNIVERSAL

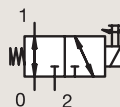

Port size	Orifice Ø 1 mm	Flow factor Qn l/min	Operating Pressure Differential			Fluid Temp.		Seat Seal	Valve Ref.	Housing Ref.	Coil Ref.	ATEX Zone	Protection Mode	Power		Coil Group	Dwg. No.
			Min	Max (MOPD) AC bar DC bar	Min	Max	AC W							DC W			
SB	2	140	0	7	7	-10	100	FKM	133F4650 <sub>1</sub>	2995	481865	-	-	8	9	2.1	3509
	2	140	0	7	7	-10	120	FKM	133F4650 <sub>1</sub>	4270	481000	-	-	8	8	2.1	3509

Notes:

1. With manual override

### 3 & 5 WAY PNEUMATIC DISTRIBUTORS



For this page	Port size	Orifice (mm)	Qn (l/min)	MOPD (bar)	Fluid Temp (°C)
From	1/8"	2	140	2	-20
To	5 mm	2.5	180	7	120

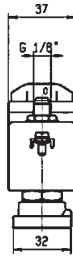
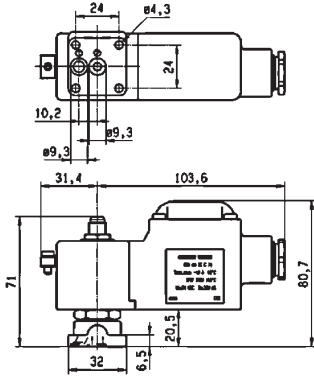

Drawing 8022

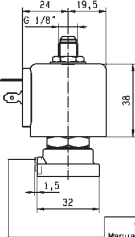
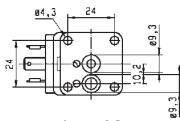

OPTION  
Manual override  
121...131F...50

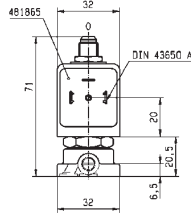

Drawing 3509

**3 & 5 WAY  
PNEUMATIC  
DISTRIBUTORS**

# 3/2

## 3 & 5 WAY PNEUMATIC VALVES FOR ACTUATOR CONTROL (PIPE MOUNTING) DIRECT OPERATED

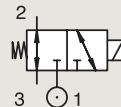
**ANODIZED ALUMINIUM  
PIPE MOUNTING**
**UNIVERSAL**

Port size	Orifice Ø	Flow factor	Operating Pressure Differential		Fluid Temp.		Seat Seal	Valve Ref.	Housing Ref.	Coil Ref.	ATEX Zone	Protection Mode	Power		Coil Group	Dwg. No.	
			Min	Max (MOPD)	Min	Max							AC W	DC W			
BSP	1	Qn	bar	AC bar	DC bar	°C	°C										
1/4"	6	680	0	12	12	-25	75	NBR	133X01	-	492310	1-21	Ex e mb II T3 to T6	6	6	9.0/10.1/10.2	6960
	6	680	0	12	12	-25	65	NBR	133X01	-	492965.01	0-20	Ex ia IIC T6	-	0.3 to 3	9.0/10.1/10.2	6960
	6	680	0	12	12	-25	65	NBR	133X01	-	496700	1-21	Ex d mb IIC T4 to T6	6	6	9.0/10.1/10.2	6960
	6	680	0	12	12	-25	65	NBR	133X01	-	496895	-	-	8	8	9.0/10.1/10.2	6960
1/4" NPT	6	680	0	12	12	-25	65	NBR	U133X01	-	496700	1-21	Ex d mb IIC T4 to T6	6	6	9.0/10.1/10.2	7422



### 3 & 5 WAY PNEUMATIC DISTRIBUTORS



For this page	Port size	Orifice (mm)	Qn (l/min)	MOPD (bar)	Fluid Temp (°C)
From	1/4"	6	680	10	-25
To	1/4"	6	680	10	75

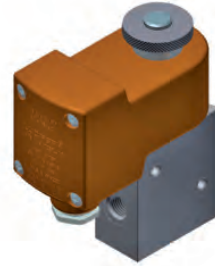
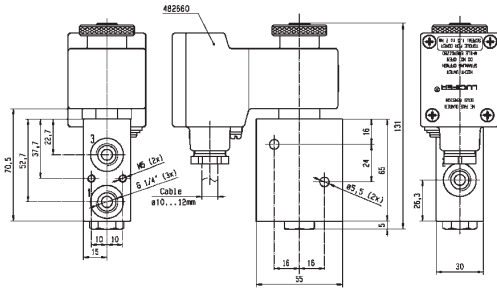

Drawing 6960

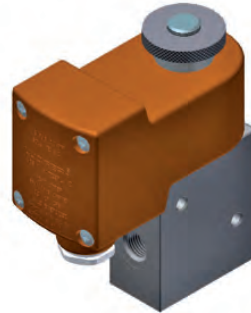
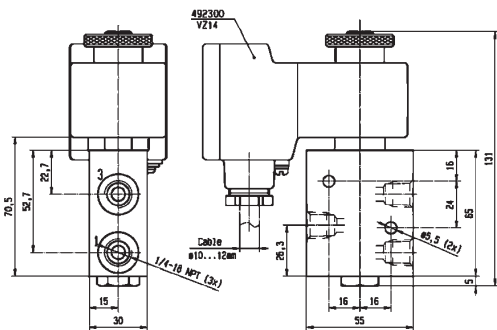

Drawing 7422



### 3 & 5 WAY PNEUMATIC DISTRIBUTORS

# 5/2

## 3 & 5 WAY PNEUMATIC VALVES FOR ACTUATOR CONTROL (PIPE MOUNTING) PILOT OPERATED

### ANODIZED ALUMINIUM

### PIPE MOUNTING

### NORMALLY CLOSED

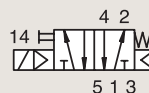

Port size	Orifice Ø	Flow factor	Operating Pressure Differential			Fluid Temp.		Seat Seal	Valve Ref.	Housing Ref.	Coil Ref.	ATEX Zone	Protection Mode	Power		Coil Group	Dwg. No.
			Min	Max (MOPD)	DC bar	Min	Max							AC W	DC W		
1/8"	4	600	2	10	10	-25	50	NBR	341P01 <sub>2</sub>	-	482606	1-21	Ex mb IIC T4/T5	2	2.5	1.1	7302
	4	600	2	10	10	-25	80	NBR	341P01 <sub>2</sub>	8993	488980	-	-	2	2.5	1.1	7302
	4	600	2	10	10	-25	80	NBR	341P21 <sub>12</sub>	2995	481865	-	-	8	9	2.1	7296
	4	600	2	10	10	-25	80	NBR	341P21 <sub>12</sub>	4270	481000	-	-	8	8	2.1	7296
	4	600	2	10	10	-40	65	PUR	341P2108 <sub>2</sub>	2995	481865	-	-	8	9	2.1	7296
	4	600	2	10	10	-40	65	PUR	341P2108 <sub>2</sub>	4270	481000	-	-	8	8	2.1	7296
	4	600	2	-	10	-20	65	NBR/ PUR	341P2197 <sub>2</sub>	2995	482740	-	-	-	1.6	6.0/8.0	8027
	4	600	2	10	10	-20	65	NBR/ PUR	341P2197 <sub>2</sub>	-	495900	1-21	Ex d mb IIC T4 to T6	2.5	2	6.0/8.0	8027
	4	600	2	-	10	-20	65	NBR/ PUR	341P2197 <sub>2</sub>	-	495910	0-20	Ex ia IIC T4 to T6	-	0.3 to 3	6.0/8.0	8027
	4	600	2	-	10	-20	65	NBR/ PUR	341P2197 <sub>2</sub>	2995	496125	2-22	Ex nAC IIC T5/T6	-	1.6	6.0/8.0	8027
	4	600	2	-	10	-20	55	NBR/ PUR	341P2197 <sub>23</sub>	2995	483580.01	0-20	Ex ia IIC T6	-	0.5 to 3	6.0/7.0/8.0	8027

**Notes:**

1. Pilot seat in FKM
2. With manual override
3. A minimum current of 65 mA is required with this coil configuration



### 3 & 5 WAY PNEUMATIC DISTRIBUTORS



For this page	Port size	Orifice (mm)	Qn (l/min)	MOPD (bar)	Fluid Temp (°C)
From	1/8"	4	600	10	-40
To	1/8"	4	600	10	80

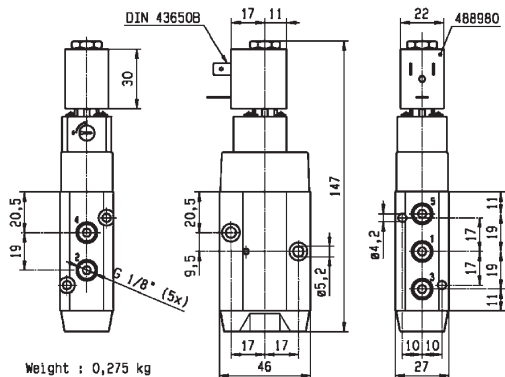

Drawing 7302

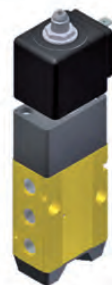
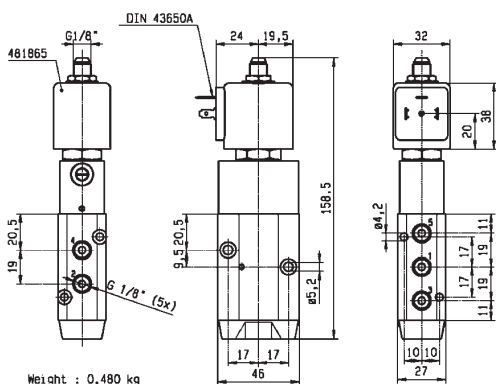

Drawing 7296

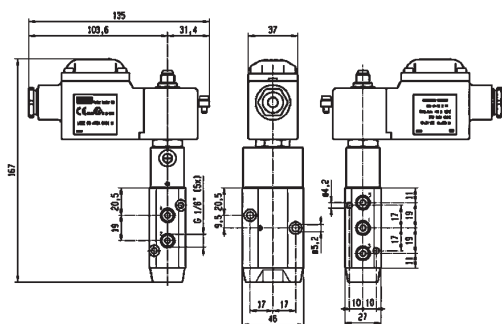

Drawing 8027



### 3 & 5 WAY PNEUMATIC DISTRIBUTORS

# 5/2

## 3 & 5 WAY PNEUMATIC VALVES FOR ACTUATOR CONTROL (PIPE MOUNTING) PILOT OPERATED

### ANODIZED ALUMINIUM PIPE MOUNTING

### NORMALLY CLOSED

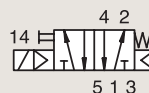

Port size	Orifice Ø	Flow factor	Operating Pressure Differential			Fluid Temp.		Seat Seal	Valve Ref.	Housing Ref.	Coil Ref.	ATEX Zone	Protection Mode	Power		Coil Group	Dwg. No.
			Min	Max (MOPD)	DC bar	Min °C	Max °C							AC W	DC W		
1/8"	15	600	2	-	10	-10	55	NBR	341P2190	2995	483580.01	0-20	Ex ia IIC T6	-	0.5 to 3	7.0	7351
														-	0.3 to 3		
														-	0.3 to 3		
1/8"	15	600	2	-	10	-10	75	NBR	341P2190	-	488660.01	0-20	Ex ia IIC T6	-	0.3 to 3	7.0	7351
														-	0.3 to 3		
														-	0.3 to 3		
1/8"	15	600	2	-	10	-10	75	NBR	341P2190	-	495910	0-20	Ex ia IIC T4 to T6	-	0.3 to 3	7.0	7351
														-	0.3 to 3		
														-	0.3 to 3		

**Notes:**

1. Pilot seat in FKM
2. With manual override
3. A minimum current of 65 mA is required with this coil configuration

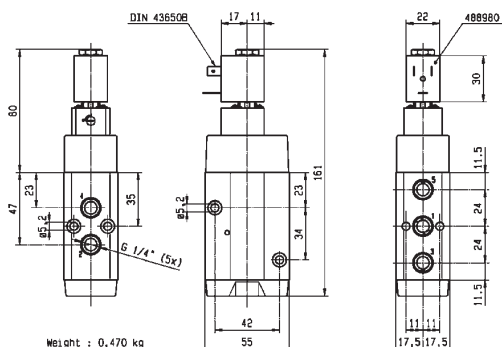

Drawing 7314



### 3 & 5 WAY PNEUMATIC DISTRIBUTORS



For this page	Port size	Orifice (mm)	Qn (l/min)	MOPD (bar)	Fluid Temp (°C)
From	1/8"	7	600	10	-25
To	1/4"	15	1400	10	80

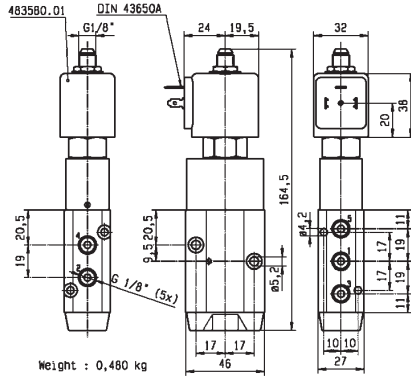

Drawing 7351

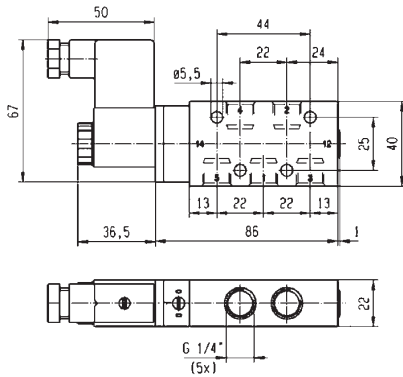

Drawing 8218

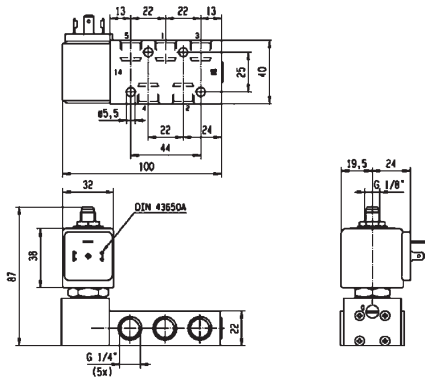

Drawing 8219



### 3 & 5 WAY PNEUMATIC DISTRIBUTORS

# 5/2

## 3 & 5 WAY PNEUMATIC VALVES FOR ACTUATOR CONTROL (PIPE MOUNTING) PILOT OPERATED

### ANODIZED ALUMINIUM PIPE MOUNTING

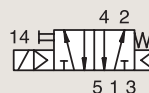

### NORMALLY CLOSED

Port size	Orifice Ø	Flow factor	Operating Pressure Differential			Fluid Temp.		Seat Seal	Valve Ref.	Housing Ref.	Coil Ref.	ATEX Zone	Protection Mode		Power		Coil Group	Dwg. No.
			Min	Max (MOPD)	DC bar	Min	Max						AC W	DC W				
BSP	1	Qn l/min	bar	AC bar	DC bar	°C	°C											
1/4"	7	1250	2.5	10	10	-10	50	NBR	341P03 <sub>2</sub>	-	496131	-	-	3	3	1.2	8218	
	7	1250	2.5	10	10	-10	50	NBR	341P03 <sub>2</sub>	-	496482	-	-	3	3	1.2	8218	
	7	1250	2.5	10	10	-10	50	NBR	341P03 <sub>2</sub>	-	496637	22	Ex tD A22 IP65 - T95°C	3	3	1.2	8218	
	7	1250	2.5	10	10	-20	50	NBR	341P33 <sub>2</sub>	2995	481865	-	-	8	9	2.1	8219	
	7	1250	2.5	10	10	-20	50	NBR	341P33 <sub>2</sub>	-	495870	2-22	Ex nAC IIC T3/T4	8	9	2.1	8219	
	7	1250	2.5	10	10	-20	50	NBR	341P33 <sub>2</sub>	-	495905	1-21	Ex d mb IIC T4	8	8	2.1	8219	
	8	1400	2	10	10	-25	80	NBR	341P02 <sub>2</sub>	-	482606	1-21	Ex mb IIC T4/T5	2	2.5	1.1	7314	
	8	1400	2	10	10	-25	80	NBR	341P02 <sub>2</sub>	8993	488980	-	-	2	2.5	1.1	7314	

**Notes:**

1. Pilot seat in FKM
2. With manual override
3. A minimum current of 65 mA is required with this coil configuration



### 3 & 5 WAY PNEUMATIC DISTRIBUTORS



For this page	Port size	Orifice (mm)	Qn (l/min)	MOPD (bar)	Fluid Temp (°C)
From	1/4"	8	1400	10	-25
To	1/4"	8	1400	10	80

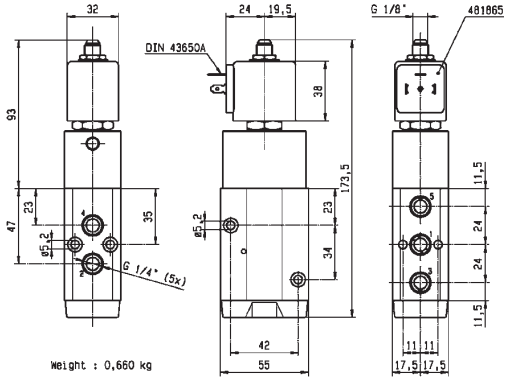

Weight : 0,660 kg



Drawing 7319

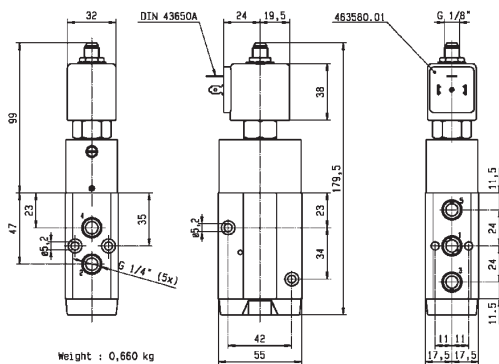

Weight : 0,660 kg



Drawing 7352

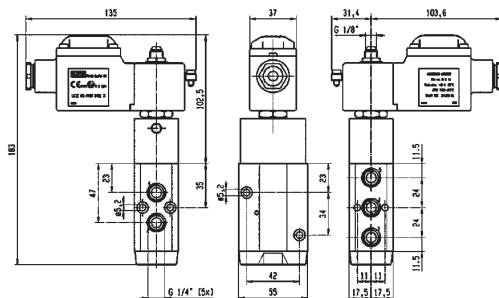

Drawing 8030



**3 & 5 WAY  
PNEUMATIC  
DISTRIBUTORS**

# 5/2

## 3 & 5 WAY PNEUMATIC VALVES FOR ACTUATOR CONTROL (PIPE MOUNTING) PILOT OPERATED

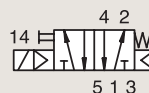
**ANODIZED ALUMINIUM  
PIPE MOUNTING**

**NORMALLY CLOSED**

Port size	Orifice Ø	Flow factor	Operating Pressure Differential			Fluid Temp.		Seat Seal	Valve Ref.	Housing Ref.	Coil Ref.	ATEX Zone	Protection Mode	Power		Coil Group	Dwg. No.
			Min	Max (MOPD)	DC bar	Min	Max							AC W	DC W		
1/4"	8	1400	2	10	10	-25	80	NBR	341P22 <sub>2</sub>	2995	481865	-	-	8	9	2.1	7319
	8	1400	2	10	10	-25	80	NBR	341P22 <sub>2</sub>	4270	481000	-	-	8	8	2.1	7319
	8	1400	2	-	10	-25	55	NBR	341P2290	2995	483580.01	0-20	Ex ia IIC T6	-	0.5 to 3	7.0	7352
	8	1400	2	-	10	-25	75	NBR	341P2290	-	488660.01	0-20	Ex ia IIC T6	-	0.3 to 3	7.0	7352
	8	1400	2	-	10	-25	75	NBR	341P2290	-	495910	0-20	Ex ia IIC T4 to T6	-	0.3 to 3	7.0	7352
	8	1400	2	-	10	-20	80	NBR/PUR	341P2297 <sub>2</sub>	2995	482740	-	-	-	1.6	6.0/8.0	8030
	8	1400	2	10	10	-20	80	NBR/PUR	341P2297 <sub>2</sub>	-	495900	1-21	Ex d mb IIC T4 to T6	2.5	2	6.0/8.0	8030
	8	1400	2	-	10	-20	80	NBR/PUR	341P2297 <sub>2</sub>	-	495910	0-20	Ex ia IIC T4 to T6	-	0.3 to 3	6.0/8.0	8030
	8	1400	2	-	10	-20	80	NBR/PUR	341P2297 <sub>2</sub>	2995	496125	2-22	Ex nAC IIC T5/T6	-	1.6	6.0/8.0	8030
	8	1400	2	-	10	-20	55	NBR/PUR	341P2297 <sub>23</sub>	2995	483580.01	0-20	Ex ia IIC T6	-	0.5 to 3	6.0/7.0/8.0	8030
1/2"	12	3000	2.5	10	10	-10	50	NBR	341P04 <sub>2</sub>	-	496131	-	-	3	3	1.2	8220
	12	3000	2.5	10	10	-10	50	NBR	341P04 <sub>2</sub>	-	496482	-	-	3	3	1.2	8220
	12	3000	2.5	10	10	-10	50	NBR	341P04 <sub>2</sub>	-	496637	22	Ex tD A22 IP65 - T95°C	3	3	1.2	8220
	12	3000	2.5	10	10	-10	50	NBR	341P34 <sub>2</sub>	2995	481865	-	-	8	9	2.1	8221
	12	3000	2.5	10	10	-10	50	NBR	341P34 <sub>2</sub>	2995	495870	2-22	Ex nAC IIC T3/T4	8	9	2.1	8221
	12	3000	2.5	10	10	-10	50	NBR	341P34 <sub>2</sub>	-	495905	1-21	Ex d mb IIC T4	8	8	2.1	8221

**Notes:**

1. Pilot seat in FKM
2. With manual override
3. A minimum current of 65 mA is required with this coil configuration



### 3 & 5 WAY PNEUMATIC DISTRIBUTORS



For this page	Port size	Orifice (mm)	Qn (l/min)	MOPD (bar)	Fluid Temp (°C)
From	1/2"	12	3000	10	-10
To	1/2"	12	3000	10	50

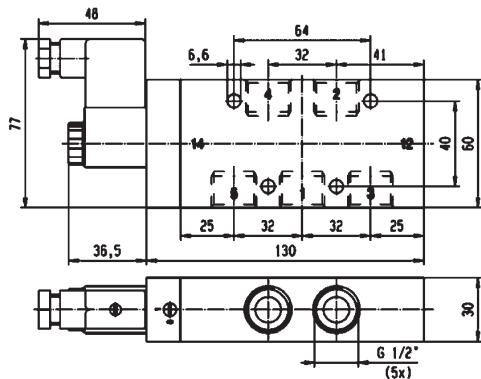

Drawing 8220

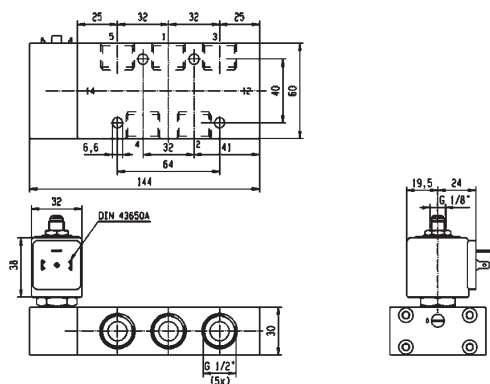

Drawing 8221

### 3 & 5 WAY PNEUMATIC DISTRIBUTORS

# 5/2

## 3 & 5 WAY PNEUMATIC VALVES FOR ACTUATOR CONTROL (PIPE MOUNTING) PILOT OPERATED

### ANODIZED ALUMINIUM PIPE MOUNTING

### DUAL SOLENOIDS

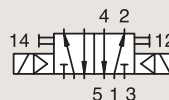

Port size	Orifice Ø	Flow factor	Operating Pressure Differential			Fluid Temp.		Seat Seal	Valve Ref.	Housing Ref.	Coil Ref.	ATEX Zone	Protection Mode	Power		Coil Group	Dwg. No.
			Min	Max	AC bar	DC bar	Min °C							Max °C	AC W		
1/8"	4	400	2	10	10	-25	80	NBR	347P01 <sub>2</sub>	-	482606	1-21	Ex mb IIC T4/T5	2	2.5	1.1	7306
	4	400	2	10	10	-25	80	NBR	347P01 <sub>2</sub>	8993	488980	-	-	2	2.5	1.1	7306
	4	400	2	10	10	-25	80	NBR	347P21 <sub>12</sub>	2995	481865	-	-	8	9	2.1	7298
	4	400	2	10	10	-25	80	NBR	347P21 <sub>12</sub>	4270	481000	-	-	8	8	2.1	7298
	4	400	2	-	10	-25	55	NBR	347P2190	2995	483580.01	0-20	Ex ia IIC T6	-	0.5 to 3	7.0	7353
	4	400	2	-	10	-25	75	NBR	347P2190	-	488660.01	0-20	Ex ia IIC T6	-	0.3 to 3	7.0	7353
	4	400	2	-	10	-25	75	NBR	347P2190	-	495910	0-20	Ex ia IIC T4 to T6	-	0.3 to 3	7.0	7353
	4	400	2	-	10	-20	65	NBR/PUR	347P2197 <sub>2</sub>	2995	482740	-	-	-	1.6	6.0/8.0	8028
	4	400	2	10	10	-20	65	NBR/PUR	347P2197 <sub>2</sub>	-	495900	1-21	Ex d mb IIC T4 to T6	2.5	2	6.0/8.0	8028
	4	400	2	-	10	-20	65	NBR/PUR	347P2197 <sub>2</sub>	-	495910	0-20	Ex ia IIC T4 to T6	-	0.3 to 3	6.0/8.0	8028
	4	400	2	-	10	-20	65	NBR/PUR	347P2197 <sub>2</sub>	2995	496125	2-22	Ex nAC IIC T5/T6	-	1.6	6.0/8.0	8028
	4	400	2	-	10	-20	55	NBR/PUR	347P2197 <sub>23</sub>	2995	483580.01	0-20	Ex ia IIC T6	-	0.5 to 3	6.0/7.0/8.0	8028

**Notes:**

1. Pilot seat in FKM
2. With manual override
3. A minimum current of 65 mA is required with this coil configuration

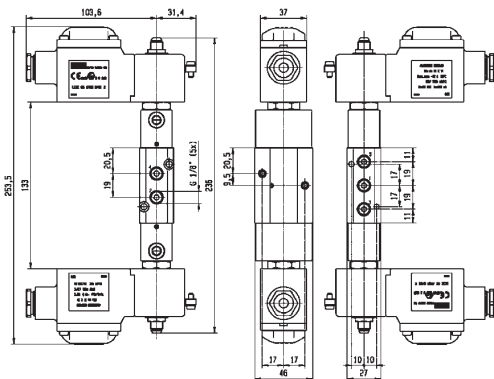

Drawing 8028



### 3 & 5 WAY PNEUMATIC DISTRIBUTORS



For this page	Port size	Orifice (mm)	Qn (l/min)	MOPD (bar)	Fluid Temp (°C)
From	1/8"	4	400	10	-25
To	1/8"	4	400	10	80

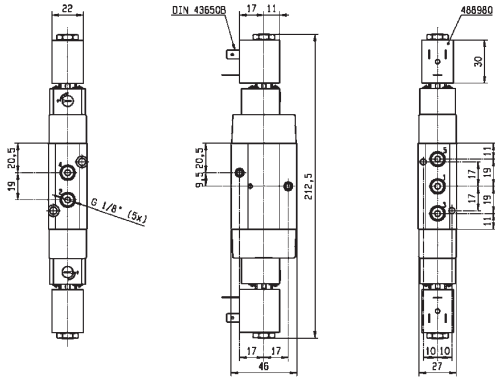

Drawing 7306

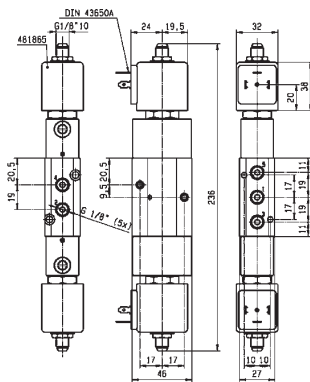

Drawing 7298

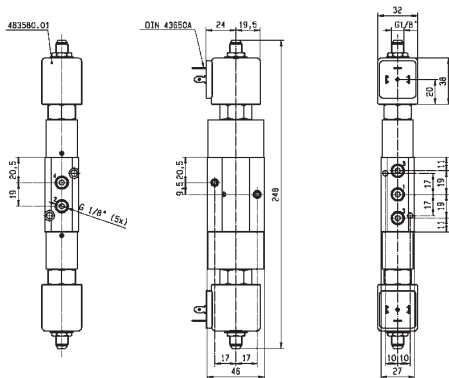

Drawing 7353



### 3 & 5 WAY PNEUMATIC DISTRIBUTORS

# 5/2

## 3 & 5 WAY PNEUMATIC VALVES FOR ACTUATOR CONTROL (PIPE MOUNTING) PILOT OPERATED

ANODIZED ALUMINIUM  
PIPE MOUNTING

DUAL SOLENOIDS

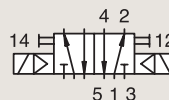

Port size	Orifice Ø	Flow factor	Operating Pressure Differential			Fluid Temp.		Seat Seal	Valve Ref.	Housing Ref.	Coil Ref.	ATEX Zone	Protection Mode		Power		Coil Group	Dwg. No.
			Min	Max (MOPD)	DC bar	Min	Max						AC W	DC W				
1/4"	7	1250	2.5	10	10	-10	50	NBR	347P03 <sub>2</sub>	-	496131	-	-	3	3	1.2	8222	
	7	1250	2.5	10	10	-10	50	NBR	347P03 <sub>2</sub>	-	496482	-	-	3	3	1.2	8222	
	7	1250	2.5	10	10	-10	50	NBR	347P03 <sub>2</sub>	-	496637	22	Ex tD A22 IP65 - T95°C	3	3	1.2	8222	
	7	1250	2.5	10	10	-10	50	NBR	347P33 <sub>2</sub>	2995	481865	-	-	8	9	2.1	8223	
	7	1250	2.5	10	10	-10	50	NBR	347P33 <sub>2</sub>	2995	495870	2-22	Ex nAC IIC T3/T4	8	9	2.1	8223	
	7	1250	2.5	10	10	-10	50	NBR	347P33 <sub>2</sub>	-	495905	1-21	Ex d mb IIC T4	8	8	2.1	8223	
	8	1400	2	10	10	-25	80	NBR	347P02 <sub>2</sub>	-	482606	1-21	Ex mb IIC T4/T5	2	2.5	1.1	7316	
	8	1400	2	10	10	-25	80	NBR	347P02 <sub>2</sub>	8993	488980	-	-	2	2.5	1.1	7316	
	8	1400	2	10	10	-25	80	NBR	347P22 <sub>2</sub>	2995	481865	-	-	8	9	2.1	7321	
	8	1400	2	10	10	-25	80	NBR	347P22 <sub>2</sub>	4270	481000	-	-	8	8	2.1	7321	

Notes:

1. Pilot seat in FKM
2. With manual override
3. A minimum current of 65 mA is required with this coil configuration

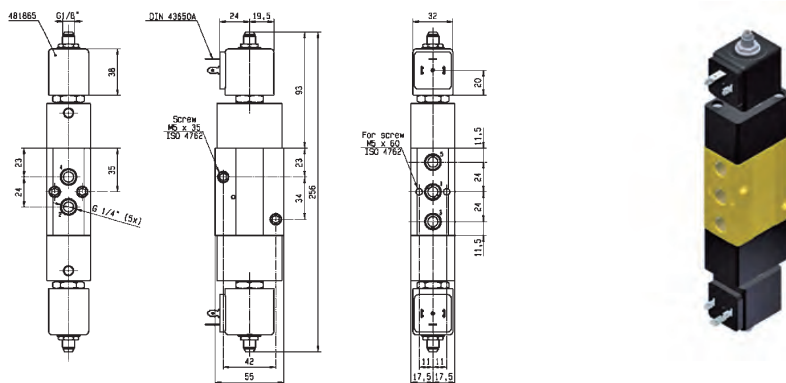

Drawing 7321



### 3 & 5 WAY PNEUMATIC DISTRIBUTORS



For this page	Port size	Orifice (mm)	Qn (l/min)	MOPD (bar)	Fluid Temp (°C)
From	1/4"	7	1250	10	-25
To	1/4"	8	1400	10	80

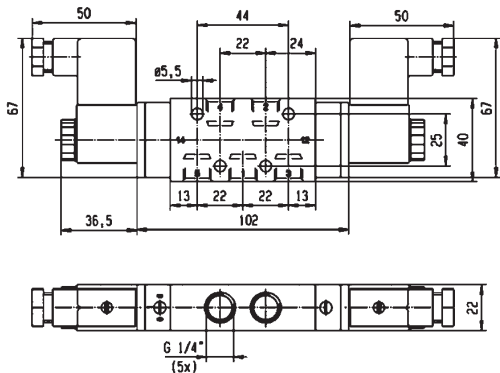

Drawing 8222

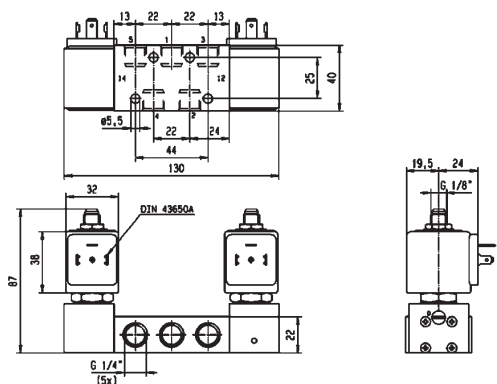

Drawing 8223

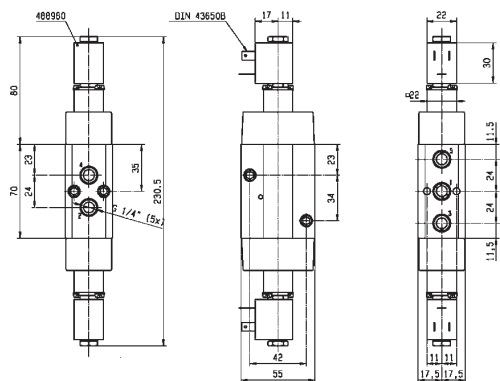

Drawing 7316



### 3 & 5 WAY PNEUMATIC DISTRIBUTORS

# 5/2

## 3 & 5 WAY PNEUMATIC VALVES FOR ACTUATOR CONTROL (PIPE MOUNTING) PILOT OPERATED

### ANODIZED ALUMINIUM

#### PIPE MOUNTING

#### DUAL SOLENOIDS

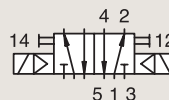

Port size	Orifice Ø	Flow factor	Operating Pressure Differential			Fluid Temp.		Seat Seal	Valve Ref.	Housing Ref.	Coil Ref.	ATEX Zone	Protection Mode	Power		Coil Group	Dwg. No.		
			Min	Max (MOPD)	DC bar	Min	Max							AC W	DC W				
1/2"	12	3000	2.5	10	10	-10	50	NBR	347P04 <sub>2</sub>	-	496131	-	-	3	3	1.2	8224		
														3	3				
														3	3				
														22	Ex tD A22 IP65 - T95°C			3	3
														8	9			2.1	8225
														8	9			2.1	8225
8	8	2.1	8225																

#### Notes:

1. Pilot seat in FKM
2. With manual override
3. A minimum current of 65 mA is required with this coil configuration

### ANODIZED ALUMINIUM

#### PIPE MOUNTING

#### CONTROL BY ELECTRIC IMPULSE

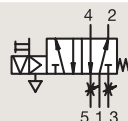

Port size	Orifice Ø	Flow factor	Operating Pressure Differential			Fluid Temp.		Seat Seal	Valve Ref.	Housing Ref.	Coil Ref.	ATEX Zone	Protection Mode	Power		Coil Group	Dwg. No.
			Min	Max (MOPD)	DC bar	Min	Max							AC W	DC W		
1/8"	4	600	2	-	10	-25	80	NBR	345P21	4269	485400	-	-	-	13	4.0	8123



3 & 5 WAY  
PNEUMATIC  
DISTRIBUTORS

UK CA IECEx certified EX CE

CS DVE EX EAC

For this page	Port size	Orifice (mm)	Qn (l/min)	MOPD (bar)	Fluid Temp (°C)
From	1/8"	4	600	10	-25
To	1/2"	12	3000	10	80

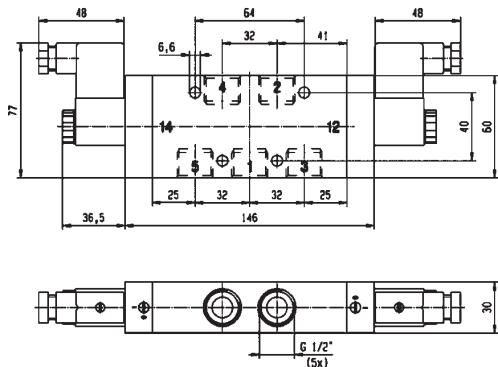

Drawing 8224

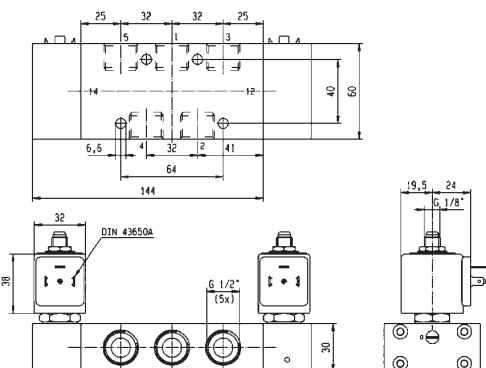

Drawing 8225

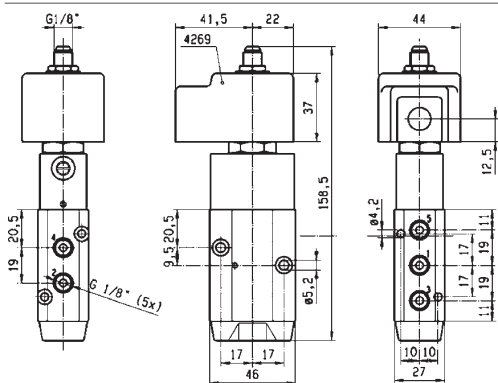

Drawing 8123



**3 & 5 WAY  
PNEUMATIC  
DISTRIBUTORS**

# 3/2

## 3 & 5 WAY PNEUMATIC VALVES FOR ACTUATOR CONTROL (PIPE MOUNTING) MANUAL RESET

**BRASS**

**PIPE MOUNTING**

**UNIVERSAL**

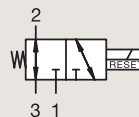

Port size	Orifice Ø	Flow factor	Operating Pressure Differential		Fluid Temp.		Seat Seal	Valve Ref.	Housing Ref.	Coil Ref.	ATEX Zone	Protection Mode	Power		Coil Group	Dwg. No.	
			Min	Max (MOPD)	Min	Max							AC W	DC W			
BSP	mm	Qn l/min	bar	AC bar	DC bar	°C	°C										
1/4"	6	680	0	12	12	-25	65	NBR	U033X0111	-	492310	1-21	Ex e mb II T3 to T6	6	6	10.1/10.2/12.0	7641
	NPT	6	680	0	12	12	-25	65	NBR	U033X0111	-	496700	1-21	Ex d mb IIC T4 to T6	6	6	10.1/10.2/12.0



### 3 & 5 WAY PNEUMATIC DISTRIBUTORS



For this page	Port size	Orifice (mm)	Qn (l/min)	MOPD (bar)	Fluid Temp (°C)
From	1/4"	6	680	10	-25
To	1/4"	6	680	10	65

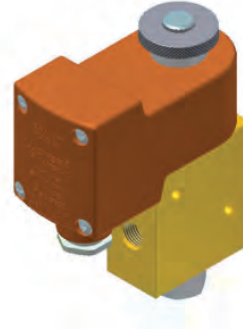
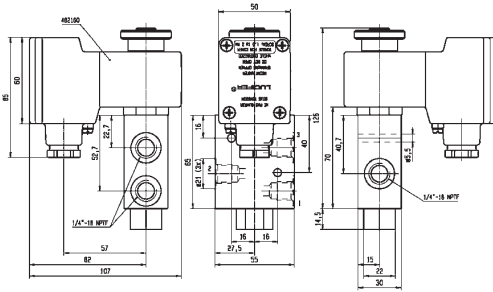

Drawing 7641



## 3 & 5 WAY PNEUMATIC DISTRIBUTORS FOR ACTUATION CONTROL



### 3 & 5 WAY PNEUMATIC VALVES FOR ACTUATOR CONTROL (NAMUR)



3/2  
5/2  
5/3

Actuation	Body	Function	Port Size	Orifice (mm)	Qn (l/min)	MOPD (bar)	Max Fluid Temp. (°C)	Page
Direct Operated	Anodized aluminium/NAMUR	Normally Closed	1/4"	6	680	10	75	302
Pilot Operated	Anodized aluminium/NAMUR/Spool	Solenoid operated - spring return	1/8"-1/4"	4 to 8	1400	10	80	308
			1/4"	7 to 8	1400	10	80	304
			1/2"	12	3000	10	50	304
		Dual Solenoids	1/8"-1/4"	4	400	10	80	320
			1/4"	7 to 8	1400	10	120	322
			1/2"	12	3000	10	120	324
		W1 closed center position	1/8"-1/4"	4	400	10	80	326
			1/4"	4 to 7	1250	10	120	326
		W3 exhausted in center position	1/4"	7	1250	10	50	328
		Control by Electric Impulse	1/8"-1/4"	4	600	10	80	330
Air Operated	Anodized aluminium/NAMUR/Poppet	Solenoid operated - spring return	1/8"-1/4"	4	355	10	75	330
	Anodized aluminium/NAMUR	Air operated - spring return	1/8"-1/4"	4	600	10	80	336
			1/4"	7	1250	10	50	336
			1/2"	12	3000	10	50	336
		Air operated and return	1/4"	7	1250	10	50	336
		W1 closed center position	1/4"	7	1250	10	50	340

### 3 & 5 WAY PNEUMATIC DISTRIBUTORS

# 3/2

## 3 & 5 WAY PNEUMATIC VALVES FOR ACTUATOR CONTROL (NAMUR) DIRECT OPERATED

### ANODIZED ALUMINIUM

### NAMUR

### NORMALLY CLOSED

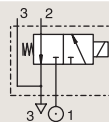

Port size	Orifice Ø	Flow factor	Operating Pressure Differential			Fluid Temp.		Seat Seal	Valve Ref.	Housing Ref.	Coil Ref.	ATEX Zone	Protection Mode	Power		Coil Group	Dwg. No.
			Min	Max (MOPD)	DC bar	Min	Max							AC W	DC W		
1/4"	6	680	0	12	12	-25	75	NBR	131X1101	-	492310	1-21	Ex e mb II T3 to T6	6	6	9.0/10.1	7336
	6	680	0	12	12	-25	75	NBR	131X1101	-	492965.01	0-20	Ex ia IIC T6	6	0.3 to 3	9.0/10.1	7336
	6	680	0	12	12	-25	75	NBR	131X1101	-	496700	1-21	Ex d mb IIC T4 to T6	6	6	9.0/10.1	7336
	6	680	0	12	12	-25	75	NBR	131X1101	-	496895	-	-	8	8	9.0/10.1	7336
	6	680	0	12	12	-25	65	NBR	131X1131 <sub>1</sub>	-	492310	1-21	Ex e mb II T3 to T6	-	6	10.1/10.2	7336
	6	680	0	12	12	-25	65	NBR	131X1131 <sub>1</sub>	-	496700	1-21	Ex d mb IIC T4 to T6	-	6	10.1/10.2	7336
1/4" NPT	6	680	0	12	12	-25	65	NBR	131X1131 <sub>1</sub>	-	496895	-	-	-	8	10.1/10.2	7336
	6	680	0	12	12	-25	75	NBR	U131X1101	-	492965.01	0-20	Ex ia IIC T6	-	0.3 to 3	10.1/10.2	7336
	6	680	0	12	12	-25	65	NBR	U131X1101	-	496700	1-21	Ex d mb IIC T4 to T6	6	6	10.1/10.2	7336
	6	680	0	12	12	-25	65	NBR	U131X1101	-	496895	-	-	8	8	10.1/10.2	7336

**Notes:**

1.DC voltage only. Minimum drop off voltage is 15% of nominal voltage (former DIN 19251)



### 3 & 5 WAY PNEUMATIC DISTRIBUTORS

IECEX  
certified



For this page	Port size	Orifice (mm)	Qn (l/min)	MOPD (bar)	Fluid Temp (°C)
From	1/4"	6	680	10	-25
To	1/4"	6	680	10	75

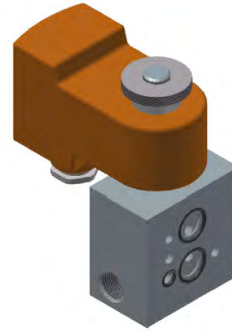
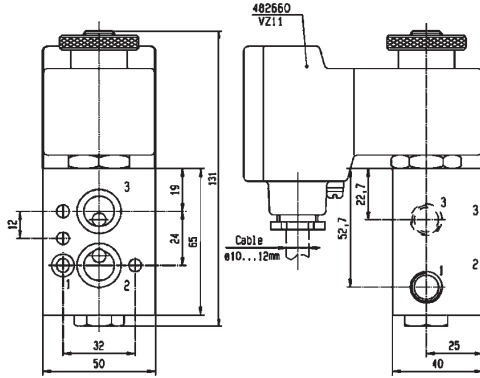

Drawing 7336

**3 & 5 WAY  
PNEUMATIC  
DISTRIBUTORS**

# 3/2

## 3 & 5 WAY PNEUMATIC VALVES FOR ACTUATOR CONTROL (NAMUR) PILOT OPERATED

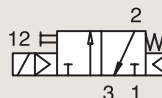
**ANODIZED ALUMINIUM**
**NAMUR**

**SOLENOID OPERATED - SPRING RETURN**

Port size	Orifice Ø 1	Flow factor Qn l/min	Operating Pressure Differential			Fluid Temp.		Seat Seal	Valve Ref.	Housing Ref.	Coil Ref.	ATEX Zone	Protection Mode	Power		Coil Group	Dwg. No.
			Min	Max (MOPD)	DC bar	Min	Max							°C	°C		
1/4"	7	1250	2.5	10	10	-10	50	NBR	331N03 <sub>3</sub>	-	496131	-	-	3	3	1.2	8056
	7	1250	2.5	10	10	-10	50	NBR	331N03 <sub>3</sub>	-	496482	-	-	3	3	1.2	8056
	7	1250	2.5	10	10	-10	50	NBR	331N03 <sub>3</sub>	-	496637	22	Ex tD A22 IP65 - T95°C	3	3	1.2	8056
1/2"	12	3000	2	10	10	-10	50	NBR	331N04 <sub>3</sub>	-	496131	-	-	3	3	1.2	8060
	12	3000	2	10	10	-10	50	NBR	331N04 <sub>3</sub>	-	496482	-	-	3	3	1.2	8060
	12	3000	2	10	10	-10	50	NBR	331N04 <sub>3</sub>	-	496637	22	Ex tD A22 IP65 - T95°C	3	3	1.2	8060

**Notes:**

1. DC voltage only. Minimum drop off voltage is 15% of nominal voltage (former DIN 19251)
2. With captured exhaust
3. With manual override

### 3 & 5 WAY PNEUMATIC DISTRIBUTORS



For this page	Port size	Orifice (mm)	Qn (l/min)	MOPD (bar)	Fluid Temp (°C)
From	1/4"	7	1250	10	-10
To	1/2"	12	3000	10	50

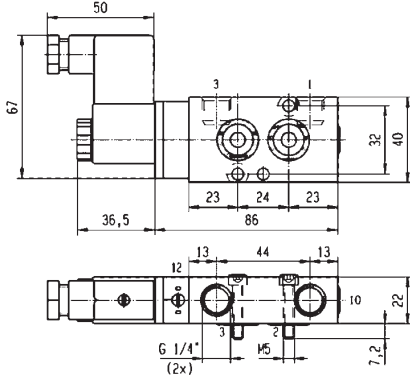

Drawing 8056

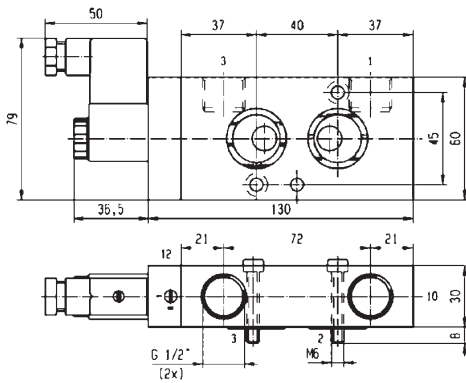

Drawing 8060

**3 & 5 WAY  
PNEUMATIC  
DISTRIBUTORS**

# 3/2

## 3 & 5 WAY PNEUMATIC VALVES FOR ACTUATOR CONTROL (NAMUR) PILOT OPERATED

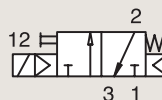
**ANODIZED ALUMINIUM**
**NAMUR**
**SOLENOID OPERATED - SPRING RETURN**

Port size	Orifice Ø	Flow factor	Operating Pressure Differential			Fluid Temp.		Seat Seal	Valve Ref.	Housing Ref.	Coil Ref.	ATEX Zone	Protection Mode	Power		Coil Group	Dwg. No.
			Min	Max (MOPD)	DC	Min	Max							AC W	DC W		
BSP	mm	Qn l/min	bar	AC bar	DC bar	°C	°C										
1/2"	12	3000	2.5	10	10	-10	50	NBR	331N34 <sub>3</sub>	2995	481865	-	-	8	9	2.1	8210
	12	3000	2.5	10	10	-10	50	NBR	331N34 <sub>3</sub>	2995	495870	2-22	Ex nAC IIC T3/T4	8	9	2.1	8210
	12	3000	2.5	10	10	-10	50	NBR	331N34 <sub>3</sub>	-	495905	1-21	Ex d mb IIC T4	8	8	2.1	8210

**Notes:**

1. DC voltage only. Minimum drop off voltage is 15% of nominal voltage (former DIN 19251)
2. With captured exhaust
3. With manual override



### 3 & 5 WAY PNEUMATIC DISTRIBUTORS



For this page	Port size	Orifice (mm)	Qn (l/min)	MOPD (bar)	Fluid Temp (°C)
From	1/2"	12	3000	10	-10
To	1/2"	12	3000	10	50

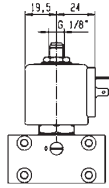
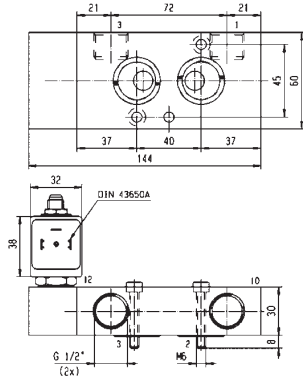

Drawing 8210

### 3 & 5 WAY PNEUMATIC DISTRIBUTORS

# 3/2-5/2

## 3 & 5 WAY PNEUMATIC VALVES FOR ACTUATOR CONTROL (NAMUR) PILOT OPERATED

ANODIZED ALUMINIUM

NAMUR

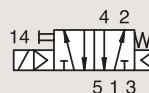

SOLENOID OPERATED - SPRING RETURN

Port size	Orifice Ø	Flow factor	Operating Pressure Differential		Fluid Temp.		Seat Seal	Valve Ref.	Housing Ref.	Coil Ref.	ATEX Zone	Protection Mode	Power		Coil Group	Dwg. No.	
			Min	Max (MOPD)	Min	Max							AC W	DC W			
1/8"- 1/4"	4	600	2	10	10	-25	80	NBR	341N01 <sub>23</sub>	8993	488980	-	-	2	2.5	1.1	7301
	4	600	2	10	10	-25	80	NBR	341N11 <sub>23</sub>	8993	488980	-	-	2	2.5	1.1	7300
	4	600	2	10	10	-25	80	NBR	341N21 <sub>3</sub>	2995	481865	-	-	8	9	2.1	7311
	4	600	2	10	10	-25	80	NBR	341N21 <sub>3</sub>	4270	481000	-	-	8	8	2.1	7311
	4	600	2	-	10	-25	55	NBR	341N2190 <sub>3</sub>	2995	483580.01	0-20	Ex ia IIC T6	-	0.5 to 3	7.0/8.0	7874
	4	600	2	-	10	-25	55	NBR	341N2190 <sub>3</sub>	-	495910	0-20	Ex ia IIC T4 to T6	-	0.3 to 3	7.0/8.0	7874

**Notes:**

- 1. DC voltage only. Minimum drop off voltage is 15% of nominal voltage (former DIN 19251)
- 2. With captured exhaust
- 3. With manual override

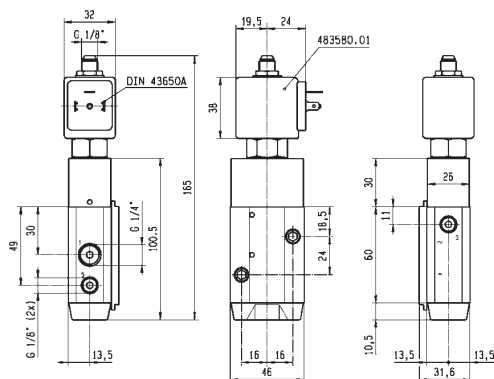

Drawing 7874



### 3 & 5 WAY PNEUMATIC DISTRIBUTORS



For this page	Port size	Orifice (mm)	Qn (l/min)	MOPD (bar)	Fluid Temp (°C)
From	1/8"-1/4"	4	600	10	-25
To	1/8"-1/4"	4	600	10	80

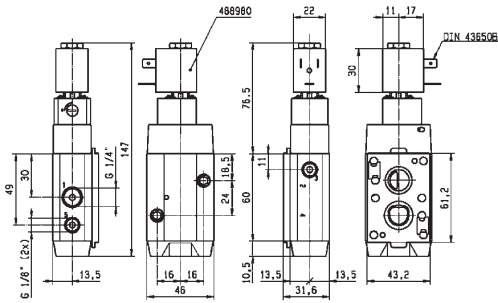

Drawing 7301

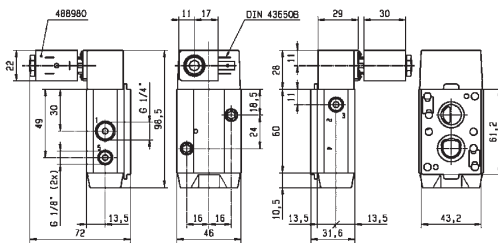

Drawing 7300

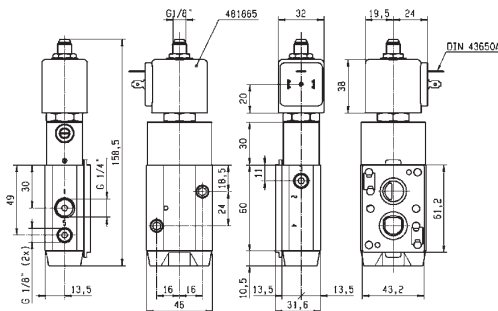

Drawing 7311

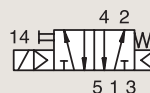

## 3 & 5 WAY PNEUMATIC VALVES FOR ACTUATOR CONTROL (NAMUR) PILOT OPERATED

**ANODIZED ALUMINIUM**
**NAMUR**

**SOLENOID OPERATED - SPRING RETURN**

Port size	Orifice Ø	Flow factor	Operating Pressure Differential		Fluid Temp.		Seat Seal	Valve Ref.	Housing Ref.	Coil Ref.	ATEX Zone	Protection Mode	Power		Coil Group	Dwg. No.	
			Min	Max (MOPD)	Min	Max							AC W	DC W			
BSP	1	Qn l/min	bar	AC bar	DC bar	°C	°C										
1/8"-1/4"	4	600	2	10	10	-25	80	NBR	341N31 <sub>3</sub>	2995	481865	-	-	8	9	2.1	7295
	4	600	2	10	10	-25	80	NBR	341N31 <sub>3</sub>	2995	495870	2-22	Ex nAC IIC T3/T4	8	9	2.1	7295
	4	600	2	10	10	-25	65	NBR	341N31 <sub>3</sub>	-	495905	1-21	Ex d mb IIC T4	8	8	2.1	7295
	4	600	2	10	10	-25	80	NBR	341N3102	2995	481865	-	-	8	9	2.1	7295
	4	600	2	10	10	-40	65	NBR	341N3108 <sub>3</sub>	2995	481865	-	-	8	9	2.1	7295
	4	600	2	10	10	-40	65	NBR	341N3108 <sub>3</sub>	4270	481000	-	-	8	8	2.1	7295
	4	600	2	10	10	-40	65	NBR	341N3128	2995	481865	-	-	8	9	2.1	7295
	4	600	2	10	10	-40	65	NBR	341N3128	4270	481865	-	-	8	9	2.1	7295
	4	600	2	-	10	-25	80	NBR	341N3130 <sub>13</sub>	2995	481865	-	-	-	9	2.1	7295
	4	600	2	-	10	-25	40	NBR	341N3130 <sub>13</sub>	-	492190	1-21	Ex e mb IIC T3/T4	-	9	2.1	7295
	4	600	2	-	10	-25	80	NBR	341N3130 <sub>13</sub>	-	495905	1-21	Ex d mb IIC T4	-	8	2.1	7295
	4	600	2	-	10	-10	55	NBR	341N3190	2995	483580.01	0-20	Ex ia IIC T6	-	0.5 to 3	7.0	7349
	4	600	2	-	10	-10	75	NBR	341N3190	-	488660.01	0-20	Ex ia IIC T6	-	0.3 to 3	7.0	7349
	4	600	2	-	10	-10	75	NBR	341N3190	-	495910	0-20	Ex ia IIC T4 to T6	-	0.3 to 3	7.0	7349
	4	600	2	-	10	-25	65	NBR	341N3196	2995	482740	-	-	-	1.6	6.0/8.0	8017
	4	600	2	10	10	-25	65	NBR	341N3196	-	495900	1-21	Ex d mb IIC T4 to T6	2.5	2	6.0/8.0	8017
	4	600	2	-	10	-25	65	NBR	341N3196	-	495910	0-20	Ex ia IIC T4 to T6	-	0.3 to 3	6.0/8.0	8017
	4	600	2	-	10	-25	55	NBR	341N3196 <sub>24</sub>	2995	483580.01	0-20	Ex ia IIC T6	-	0.5 to 3	6.0/7.0/8.0	8017
	4	600	2	-	10	-25	65	NBR	341N3196	2995	496125	2-22	Ex nAC IIC T5/T6	-	1.6	6.0/8.0	8017
	4	600	2	-	10	-25	65	NBR	341N3197 <sub>3</sub>	2995	482740	-	-	-	1.6	6.0/8.0	8017
	4	600	2	10	10	-25	65	NBR	341N3197 <sub>3</sub>	-	495900	1-21	Ex d mb IIC T4 to T6	2.5	2	6.0/8.0	8017
	4	600	2	-	10	-25	65	NBR	341N3197 <sub>3</sub>	-	495910	0-20	Ex ia IIC T4 to T6	-	0.3 to 3	6.0/8.0	8017
	4	600	2	-	10	-25	65	NBR	341N3197 <sub>3</sub>	2995	496125	2-22	Ex nAC IIC T5/T6	-	1.6	6.0/8.0	8017
	4	600	2	-	10	-25	55	NBR	341N3197 <sub>34</sub>	2995	483580.01	0-20	Ex ia IIC T6	-	0.5 to 3	6.0/7.0/8.0	8017

**Notes:**

- DC voltage only. Minimum drop off voltage is 15% of nominal voltage (former DIN 19251)
- With captured exhaust
- With manual override
- A minimum current of 65 mA is required with this coil configuration

### 3 & 5 WAY PNEUMATIC DISTRIBUTORS



For this page	Port size	Orifice (mm)	Qn (l/min)	MOPD (bar)	Fluid Temp (°C)
From	1/8"-1/4"	4	600	10	-40
To	1/8"-1/4"	4	600	10	80

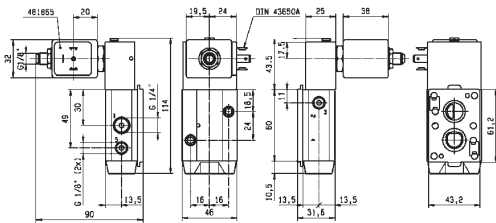

Drawing 7295

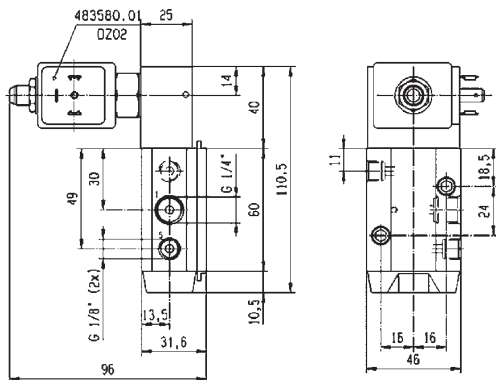

Drawing 7349

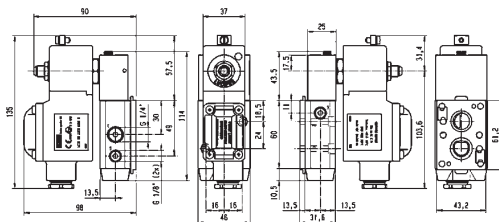

Drawing 8017



### 3 & 5 WAY PNEUMATIC DISTRIBUTORS

# 3/2-5/2

## 3 & 5 WAY PNEUMATIC VALVES FOR ACTUATOR CONTROL (NAMUR) PILOT OPERATED

### ANODIZED ALUMINIUM

### NAMUR

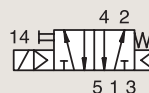

### SOLENOID OPERATED - SPRING RETURN

Port size	Orifice Ø	Flow factor	Operating Pressure Differential			Fluid Temp.		Seat Seal	Valve Ref.	Housing Ref.	Coil Ref.	ATEX Zone	Protection Mode	Power		Coil Group	Dwg. No.
			Min	Max (MOPD)	DC	Min	Max							AC W	DC W		
BSP	mm	Qn l/min	bar	AC bar	DC bar	°C	°C										
1/4"	8	1400	2	-	10	-25	55	NBR	341N3290	2995	483580.01	0-20	Ex ia IIC T6	-	0.5 to 3	7.0	7350
	8	1400	2	-	10	-25	75	NBR	341N3290	-	488660.01	0-20	Ex ia IIC T6	-	0.3 to 3	7.0	7350
	8	1400	2	-	10	-25	75	NBR	341N3290	-	495910	0-20	Ex ia IIC T4 to T6	-	0.3 to 3	7.0	7350
	8	1400	2	-	10	-25	65	NBR	341N3296	2995	482740	-	-	-	1.6	6.0/8.0	8029
	8	1400	2	10	10	-25	65	NBR	341N3296	-	495900	1-21	Ex d mb IIC T4 to T6	2.5	2	6.0/8.0	8029
	8	1400	2	-	10	-25	65	NBR	341N3296	-	495910	0-20	Ex ia IIC T4 to T6	-	0.3 to 3	6.0/8.0	8029
	8	1400	2	-	10	-20	80	NBR	341N3296	2995	496125	2-22	Ex nAC IIC T5/T6	-	1.6	6.0/8.0	8029
	8	1400	2	-	10	-20	55	NBR	341N3296 <sub>2</sub>	2995	483580.01	0-20	Ex ia IIC T6	-	0.5 to 3	6.0/7.0/8.0	8029
	8	1400	2	-	10	-25	65	NBR	341N3297 <sub>1</sub>	2995	482740	-	-	-	1.6	6.0/8.0	8029
	8	1400	2	10	10	-25	65	NBR	341N3297 <sub>1</sub>	-	495900	1-21	Ex d mb IIC T4 to T6	2.5	2	6.0/8.0	8029
	8	1400	2	-	10	-25	65	NBR	341N3297 <sub>1</sub>	-	495910	0-20	Ex ia IIC T4 to T6	-	0.3 to 3	6.0/8.0	8029
	8	1400	2	-	10	-20	80	NBR	341N3297 <sub>1</sub>	2995	496125	2-22	Ex nAC IIC T5/T6	-	1.6	6.0/8.0	8029
	8	1400	2	-	10	-20	55	NBR	341N3297 <sub>12</sub>	2995	483580.01	0-20	Ex ia IIC T6	-	0.5 to 3	6.0/7.0/8.0	8029
	7	1250	2.5	10	10	-10	50	NBR	341N05 <sub>1</sub>	-	496131	-	-	3	3	1.2	8162
	7	1250	2.5	10	10	-10	50	NBR	341N05 <sub>1</sub>	-	496482	-	-	3	3	1.2	8162
	7	1250	2.5	10	10	-10	50	NBR	341N05 <sub>1</sub>	-	496637	22	Ex tD A22 IP65 - T95°C	3	3	1.2	8162

**Notes:**

1. With manual override
2. A minimum current of 65 mA is required with this coil configuration



**3 & 5 WAY  
PNEUMATIC  
DISTRIBUTORS**



For this page	Port size	Orifice (mm)	Qn (l/min)	MOPD (bar)	Fluid Temp (°C)
From	1/8"-1/4"	7	1250	10	-25
To	1/4"	8	1400	10	80

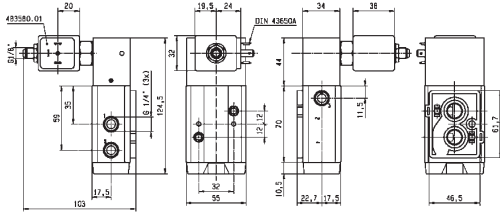

Drawing 7350

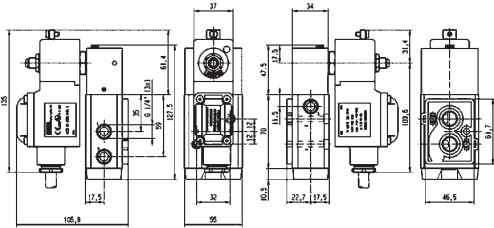

Drawing 8029

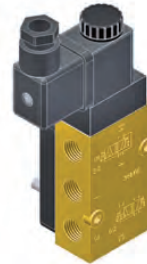
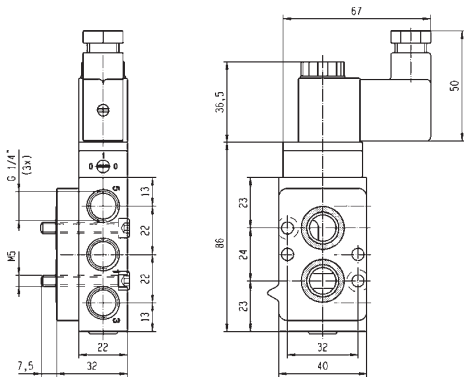

Drawing 8162



### 3 & 5 WAY PNEUMATIC DISTRIBUTORS

# 3/2-5/2

## 3 & 5 WAY PNEUMATIC VALVES FOR ACTUATOR CONTROL (NAMUR) PILOT OPERATED

### ANODIZED ALUMINIUM

### NAMUR

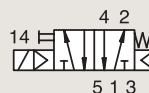

### SOLENOID OPERATED - SPRING RETURN

Port size	Orifice Ø	Flow factor	Operating Pressure Differential			Fluid Temp.		Seat Seal	Valve Ref.	Housing Ref.	Coil Ref.	ATEX Zone	Protection Mode	Power		Coil Group	Dwg. No.
			Min	Max (MOPD)	DC	Min	Max							AC W	DC W		
1/4"	7	1200	2.5	10	10	-10	50	NBR	341N0502	-	496131	-	-	3	3	1.2	8253
	7	1200	2.5	10	10	-10	50	NBR	341N0502	-	496482	-	-	3	3	1.2	8253
	7	1200	2.5	10	10	-10	50	NBR	341N35 <sub>3</sub>	2995	481865	-	-	8	9	2.1	8213
	7	1200	2.5	10	10	-10	50	NBR	341N35 <sub>3</sub>	2995	495870	2-22	Ex nAC IIC T3/T4	8	9	2.1	8213
	7	1200	2.5	10	10	-10	50	NBR	341N35 <sub>3</sub>	-	495905	1-21	Ex d mb IIC T4	8	8	2.1	8213
	7	1200	2.5	10	10	-10	50	NBR	341N3502	2995	481865	-	-	8	9	2.1	8254
	7	1200	2.5	10	10	-10	50	NBR	341N3502	4270	481000	-	-	8	8	2.1	8254
	8	1400	2	10	10	-25	80	NBR	341N02 <sub>23</sub>	8993	488980	-	-	2	2.5	1.1	7313

#### Notes:

- 1.DC voltage only. Minimum drop off voltage is 15% of nominal voltage (former DIN 19251)
- 2.With captured exhaust
- 3.With manual override

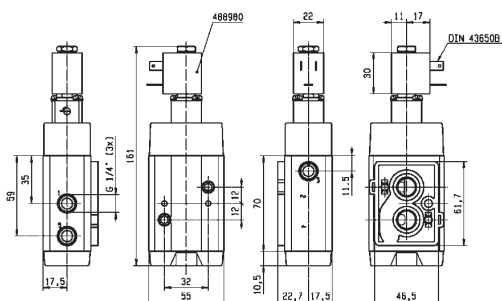

Drawing 7313



### 3 & 5 WAY PNEUMATIC DISTRIBUTORS



For this page	Port size	Orifice (mm)	Qn (l/min)	MOPD (bar)	Fluid Temp (°C)
From	1/4"	7	1200	10	-25
To	1/4"	8	1400	10	80

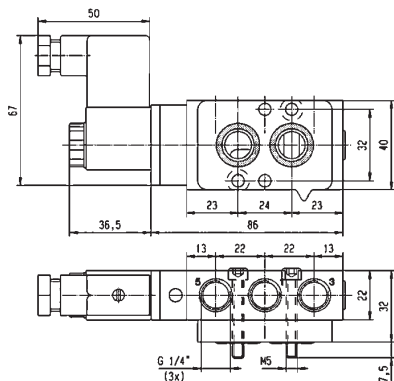

Drawing 8253

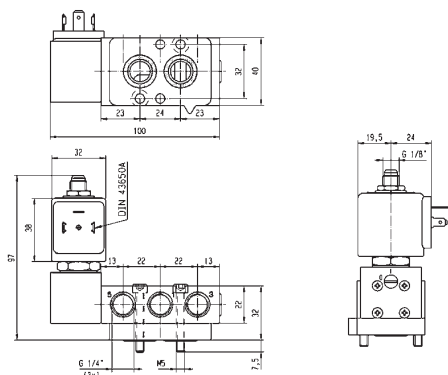

Drawing 8213

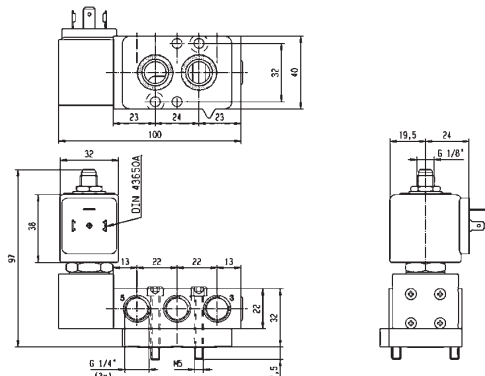

Drawing 8254



### 3 & 5 WAY PNEUMATIC DISTRIBUTORS

# 3/2-5/2

## 3 & 5 WAY PNEUMATIC VALVES FOR ACTUATOR CONTROL (NAMUR) PILOT OPERATED

### ANODIZED ALUMINIUM

### NAMUR

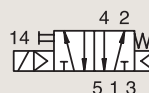

### SOLENOID OPERATED - SPRING RETURN

Port size	Orifice Ø	Flow factor	Operating Pressure Differential		Fluid Temp.		Seat Seal	Valve Ref.	Housing Ref.	Coil Ref.	ATEX Zone	Protection Mode	Power		Coil Group	Dwg. No.	
			Min	Max (MOPD)	Min	Max							AC W	DC W			
BSP	mm	Qn l/min	bar	AC bar	DC bar	°C	°C										
1/4"	8	1400	2	10	10	-25	80	NBR	341N12 <sub>23</sub>	8993	488980	-	-	2	2.5	1.1	7312
	8	1400	2	10	10	-25	80	NBR	341N22 <sub>3</sub>	2995	481865	-	-	8	9	2.1	7318
	8	1400	2	10	10	-25	80	NBR	341N22 <sub>3</sub>	4270	481000	-	-	8	8	2.1	7318
	8	1400	2	10	10	-25	80	NBR	341N32 <sub>3</sub>	2995	481865	-	-	8	9	2.1	7317
	8	1400	2	10	10	-25	80	NBR	341N32 <sub>3</sub>	2995	495870	2-22	Ex nAC IIC T3/T4	8	9	2.1	7317
	8	1400	2	10	10	-25	80	NBR	341N32 <sub>3</sub>	-	495905	1-21	Ex d mb IIC T4	8	8	2.1	7317
	8	1400	2	10	10	-25	80	NBR	341N3202	2995	481865	-	-	8	9	2.1	7317
	8	1400	2	10	10	-25	80	NBR	341N3202	2995	495870	2-22	Ex nAC IIC T3/T4	8	9	2.1	7317
8	1400	2	10	10	-25	80	NBR	341N3202	-	495905	1-21	Ex d mb IIC T4	8	8	2.1	7317	

#### Notes:

- DC voltage only. Minimum drop off voltage is 15% of nominal voltage (former DIN 19251)
- With captured exhaust
- With manual override



### 3 & 5 WAY PNEUMATIC DISTRIBUTORS



For this page	Port size	Orifice (mm)	Qn (l/min)	MOPD (bar)	Fluid Temp (°C)
From	1/4"	8	1400	10	-25
To	1/4"	8	1400	10	80

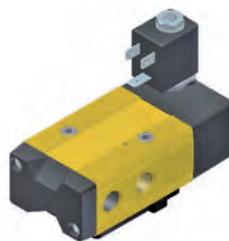
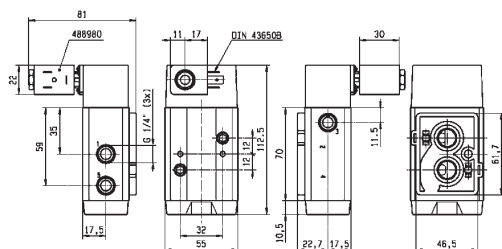

Drawing 7312

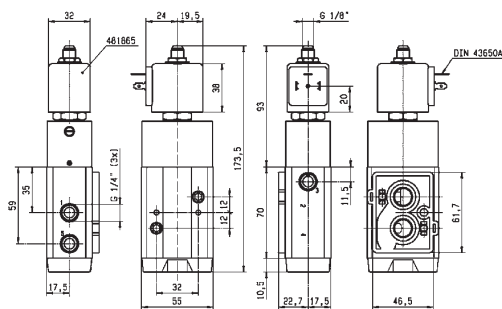

Drawing 7318

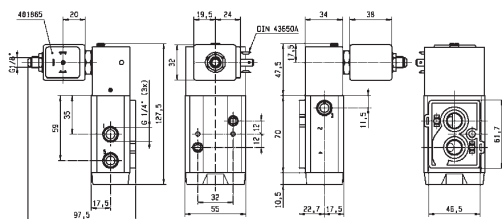

Drawing 7317



**3 & 5 WAY  
PNEUMATIC  
DISTRIBUTORS**

# 5/2

## 3 & 5 WAY PNEUMATIC VALVES FOR ACTUATOR CONTROL (NAMUR) PILOT OPERATED

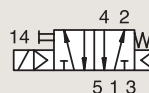
**ANODIZED ALUMINIUM**
**NAMUR**

**SOLENOID OPERATED - SPRING RETURN**

Port size	Orifice Ø	Flow factor	Operating Pressure Differential			Fluid Temp.		Seat Seal	Valve Ref.	Housing Ref.	Coil Ref.	ATEX Zone	Protection Mode	Power		Coil Group	Dwg. No.
			Min	Max (MOPD)	DC bar	Min	Max							AC W	DC W		
1/4"	7	1250	2.5	10	10	-20	50	NBR	341N03 <sub>3</sub>	-	496131	-	-	3	3	1.2	8063
	7	1250	2.5	10	10	-20	50	NBR	341N03 <sub>3</sub>	-	496482	-	-	3	3	1.2	8063
	7	1250	2.5	10	10	-20	50	NBR	341N03 <sub>3</sub>	-	496637	22	Ex tD A22 IP65 - T95°C	3	3	1.2	8063
1/2"	12	3000	2	10	10	-10	50	NBR	341N04 <sub>3</sub>	-	496131	-	-	3	3	1.2	8065
	12	3000	2	10	10	-10	50	NBR	341N04 <sub>3</sub>	-	496482	-	-	3	3	1.2	8065
	12	3000	2	10	10	-10	50	NBR	341N04 <sub>3</sub>	-	496637	22	Ex tD A22 IP65 - T95°C	3	3	1.2	8065
	12	3000	2.5	10	10	-20	50	NBR	341N34 <sub>3</sub>	2995	481865	-	-	8	9	2.1	8211
	12	3000	2.5	10	10	-20	50	NBR	341N34 <sub>3</sub>	2995	495870	2-22	Ex nAC IIC T3/T4	8	9	2.1	8211
	12	3000	2.5	10	10	-20	50	NBR	341N34 <sub>3</sub>	-	495905	1-21	Ex d mb IIC T4	8	8	2.1	8211

**Notes:**

1. DC voltage only. Minimum drop off voltage is 15% of nominal voltage (former DIN 19251)

2. With captured exhaust

3. With manual override

### 3 & 5 WAY PNEUMATIC DISTRIBUTORS



For this page	Port size	Orifice (mm)	Qn (l/min)	MOPD (bar)	Fluid Temp (°C)
From	1/4"	7	1250	10	-10
To	1/2"	12	3000	10	50

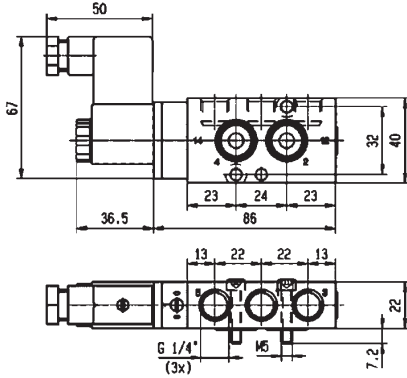

Drawing 8063

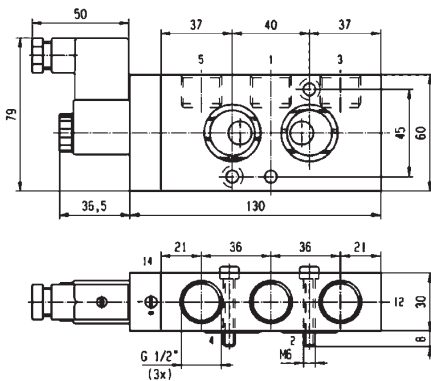

Drawing 8065

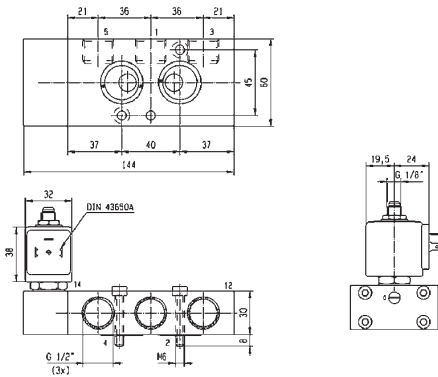

Drawing 8211



### 3 & 5 WAY PNEUMATIC DISTRIBUTORS

# 5/2

## 3 & 5 WAY PNEUMATIC VALVES FOR ACTUATOR CONTROL (NAMUR) PILOT OPERATED

### ANODIZED ALUMINIUM

### NAMUR

### DUAL SOLENOIDS

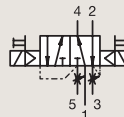

Port size	Orifice Ø	Flow factor	Operating Pressure Differential			Fluid Temp.		Seat Seal	Valve Ref.	Housing Ref.	Coil Ref.	ATEX Zone	Protection Mode	Power		Coil Group	Dwg. No.
			Min	Max	Max (MOPD)	Min	Max							AC W	DC W		
BSP	1	Qn	Min	Max	Max (MOPD)	Min	Max							AC W	DC W		
1/8"- 1/4"	4	400	2	10	10	-25	50	NBR	347N11 <sub>12</sub>	-	482606	1-21	Ex mb IIC T4/T5	2	2.5	1.1	7305
	4	400	2	10	10	-25	80	NBR	347N11 <sub>12</sub>	8993	488980	-	-	2	2.5	1.1	7305
	4	400	2	10	10	-25	80	NBR	347N31 <sub>2</sub>	2995	481865	-	-	8	9	2.1	7297
	4	400	2	10	10	-25	80	NBR	347N31 <sub>2</sub>	2995	495870	2-22	Ex nAC IIC T3/T4	8	9	2.1	7297
	4	400	2	10	10	-25	80	NBR	347N31 <sub>2</sub>	-	495905	1-21	Ex d mb IIC T4	8	8	2.1	7297
	4	400	2	-	10	-25	55	NBR	347N3190	2995	483580.01	0-20	Ex ia IIC T6	-	0.5 to 3	7.0	8141
	4	400	2	-	10	-25	65	NBR	347N3197 <sub>2</sub>	2995	482740	-	-	-	1.6	3.0/6.0/8.0	7297
	4	400	2	10	10	-25	65	NBR	347N3197 <sub>2</sub>	-	495900	1-21	Ex d mb IIC T4 to T6	2.5	2	3.0/6.0/8.0	7297
	4	400	2	-	10	-25	65	NBR	347N3197 <sub>2</sub>	-	495910	0-20	Ex ia IIC T4 to T6	-	0.3 to 3	3.0/6.0/8.0	7297
	4	400	2	-	10	-25	65	NBR	347N3197 <sub>2</sub>	2995	496125	2-22	Ex nAC IIC T5/T6	-	1.6	3.0/6.0/8.0	7297
	4	400	2	-	10	-25	55	NBR	347N3197 <sub>23</sub>	2995	483580.01	0-20	Ex ia IIC T6	-	0.5 to 3	6.0/7.0/8.0	7297

**Notes:**

1. With captured exhaust
2. With manual override
3. A minimum current of 65 mA is required with this coil configuration

### 3 & 5 WAY PNEUMATIC DISTRIBUTORS



For this page	Port size	Orifice (mm)	Qn (l/min)	MOPD (bar)	Fluid Temp (°C)
From	1/8"-1/4"	4	400	10	-25
To	1/8"-1/4"	4	400	10	80

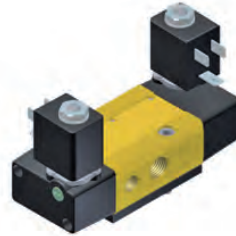
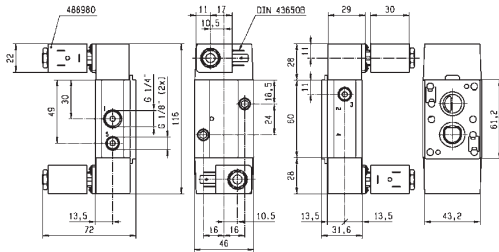

Drawing 7305

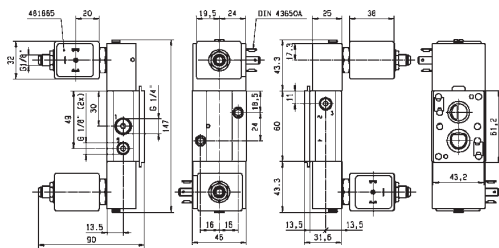

Drawing 7297

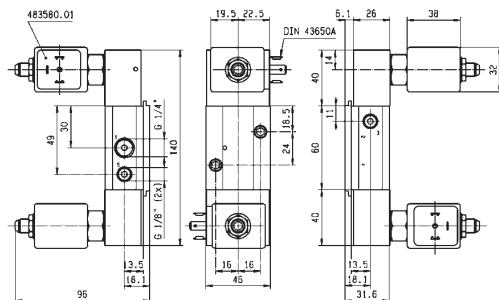

Drawing 8141



### 3 & 5 WAY PNEUMATIC DISTRIBUTORS

# 5/2

## 3 & 5 WAY PNEUMATIC VALVES FOR ACTUATOR CONTROL (NAMUR) PILOT OPERATED

### ANODIZED ALUMINIUM

### NAMUR

### DUAL SOLENOIDS

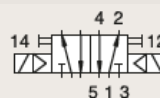

Port size	Orifice Ø	Flow factor	Operating Pressure Differential		Fluid Temp.		Seat Seal	Valve Ref.	Housing Ref.	Coil Ref.	ATEX Zone	Protection Mode	Power		Coil Group	Dwg. No.	
			Min	Max (MOPD)	Min	Max							AC W	DC W			
BSP	1	Qn	bar	bar	°C	°C	NBR										
																	mm
1/4"	7	1250	1.5	10	10	-10	50	NBR	347N03 <sub>2</sub>	-	496131	-	-	3	3	1.2	8057
	7	1250	1.5	10	10	-10	50	NBR	347N03 <sub>2</sub>	-	496482	-	-	3	3	1.2	8057
	7	1250	1.5	10	10	-10	50	NBR	347N03 <sub>2</sub>	-	496637	22	Ex tD A22 IP65 - T95°C	3	3	1.2	8057
	7	1250	2.5	10	10	-10	120	NBR	347N33 <sub>2</sub>	2995	481865	-	-	8	9	2.1	8209
	7	1250	2.5	10	10	-10	120	NBR	347N33 <sub>2</sub>	2995	495870	2-22	Ex nAC IIC T3/T4	8	9	2.1	8209
	7	1250	2.5	10	10	-10	120	NBR	347N33 <sub>2</sub>	-	495905	1-21	Ex d mb IIC T4	8	8	2.1	8209
	8	1400	2	10	10	-10	65	NBR	347N12 <sub>12</sub>	-	482606	1-21	Ex mb IIC T4/T5	2	2.5	1.1	7315
	8	1400	2	10	10	-25	80	NBR	347N12 <sub>12</sub>	8993	488980	-	-	2	2.5	1.1	7315
	8	1400	2	10	10	-25	80	NBR	347N32 <sub>2</sub>	2995	481865	-	-	8	9	2.1	7320
	8	1400	2	10	10	-25	80	NBR	347N32 <sub>2</sub>	2995	495870	2-22	Ex nAC IIC T3/T4	8	9	2.1	7320
	8	1400	2	10	10	-25	80	NBR	347N32 <sub>2</sub>	-	495905	1-21	Ex d mb IIC T4	8	8	2.1	7320

#### Notes:

1. With captured exhaust
2. With manual override
3. A minimum current of 65 mA is required with this coil configuration

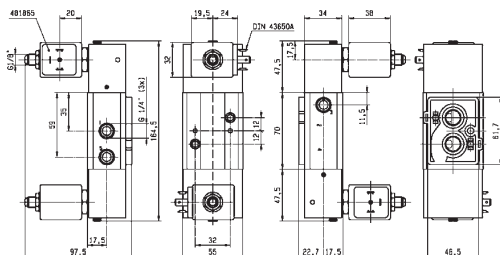

Drawing 7320



### 3 & 5 WAY PNEUMATIC DISTRIBUTORS



For this page	Port size	Orifice (mm)	Qn (l/min)	MOPD (bar)	Fluid Temp (°C)
From	1/4"	7	1250	10	-25
To	1/4"	8	1400	10	120

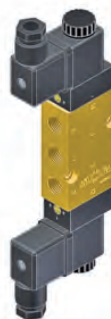
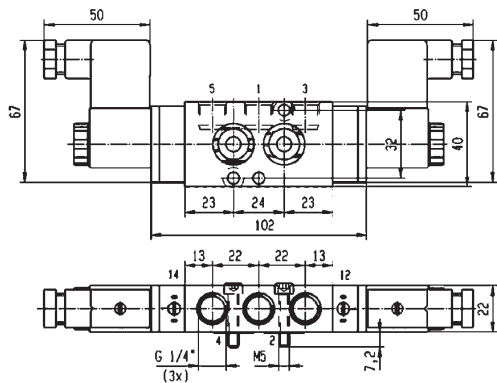

Drawing 8057

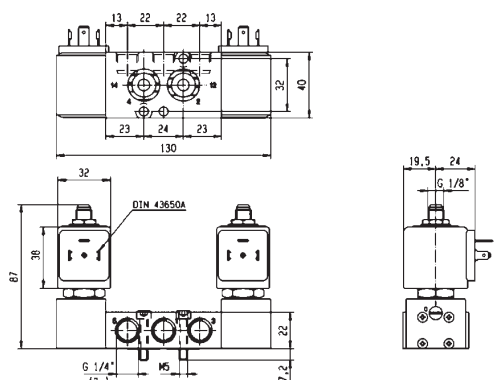

Drawing 8209

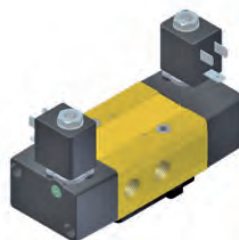
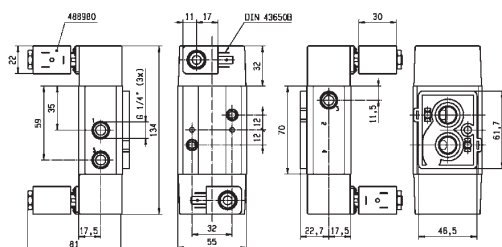

Drawing 7315



### 3 & 5 WAY PNEUMATIC DISTRIBUTORS

# 5/2

## 3 & 5 WAY PNEUMATIC VALVES FOR ACTUATOR CONTROL (NAMUR) PILOT OPERATED

### ANODIZED ALUMINIUM

### NAMUR

### DUAL SOLENOIDS

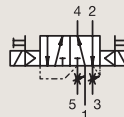

Port size	Orifice Ø	Flow factor	Operating Pressure Differential			Fluid Temp.		Seat Seal	Valve Ref.	Housing Ref.	Coil Ref.	ATEX Zone	Protection Mode	Power		Coil Group	Dwg. No.
			Min	Max (MOPD)	Max	Min	Max							AC W	DC W		
BSP	1	Qn	Min	Max (MOPD)	Max	Min	Max										
1/2"	12	3000	1.5	10	10	-10	50	NBR	347N04 <sub>2</sub>	-	496131	-	-	3	3	1.2	8154
	12	3000	1.5	10	10	-10	50	NBR	347N04 <sub>2</sub>	-	496482	-	-	3	3	1.2	8154
	12	3000	1.5	10	10	-10	50	NBR	347N04 <sub>2</sub>	-	496637	22	Ex tD A22 IP65 - T95°C	3	3	1.2	8154
	12	3000	2.5	10	10	-10	120	NBR	347N34 <sub>2</sub>	2995	481865	-	-	8	9	2.1	8212
	12	3000	2.5	10	10	-10	120	NBR	347N34 <sub>2</sub>	2995	495870	2-22	Ex nAC IIC T3/T4	8	9	2.1	8212
	12	3000	2.5	10	10	-10	120	NBR	347N34 <sub>2</sub>	-	495905	1-21	Ex d mb IIC T4	8	8	2.1	8212

#### Notes:

1. With captured exhaust
2. With manual override
3. A minimum current of 65 mA is required with this coil configuration

### 3 & 5 WAY PNEUMATIC DISTRIBUTORS



For this page	Port size	Orifice (mm)	Qn (l/min)	MOPD (bar)	Fluid Temp (°C)
From	1/2"	12	3000	10	-10
To	1/2"	12	3000	10	120

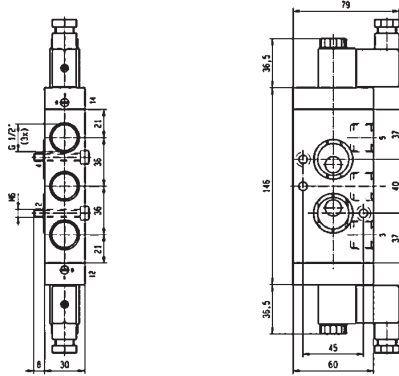

Drawing 8154

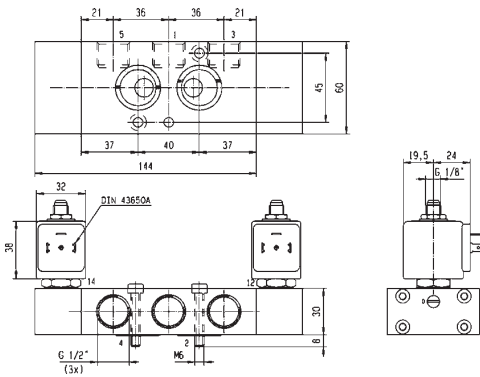

Drawing 8212

### 3 & 5 WAY PNEUMATIC DISTRIBUTORS

# 5/3

## 3 & 5 WAY PNEUMATIC VALVES FOR ACTUATOR CONTROL (NAMUR) PILOT OPERATED

### ANODIZED ALUMINIUM

### NAMUR

### W1 CLOSED CENTER POSITION

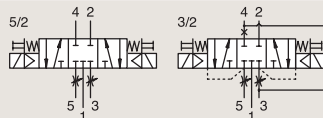

Port size	Orifice Ø	Flow factor	Operating Pressure Differential			Fluid Temp.		Seat Seal	Valve Ref.	Housing Ref.	Coil Ref.	ATEX Zone	Protection Mode	Power		Coil Group	Dwg. No.
			Min	Max (MOPD)	DC	Min	Max							AC W	DC W		
1/8"-1/4"	4	400	2	10	10	-25	80	NBR	342N11 <sub>12</sub>	-	482606	1-21	Ex mb IIC T4/T5	2	2.5	1.1	7305
	4	400	2	10	10	-25	80	NBR	342N11 <sub>12</sub>	8993	488980	-	-	2	2.5	1.1	7305
1/4"	4	400	2	-	10	-10	65	NBR	342N3197 <sub>2</sub>	-	495910	0-20	Ex ia IIC T4 to T6	-	0.3 to 3	6.0/8.0	7297
	4	400	2	-	10	-10	55	NBR	342N3197 <sub>23</sub>	2995	483580.01	0-20	Ex ia IIC T6	-	0.5 to 3	6.0/7.0/8.0	7297
	7	1250	3	10	10	-20	50	NBR	342N03 <sub>2</sub>	-	496131	-	-	3	3	1.2	8057
	7	1250	3	10	10	-20	50	NBR	342N03 <sub>2</sub>	-	496482	-	-	3	3	1.2	8057
	7	1250	3	10	10	-10	50	NBR	342N03 <sub>2</sub>	-	496637	22	Ex tD A22 IP65 - T95°C	3	3	1.2	8057
	7	1250	2.5	10	10	-20	50	NBR	342N33 <sub>2</sub>	2995	481865	-	-	8	9	2.1	8209
	7	1250	2.5	10	10	-20	50	NBR	342N33 <sub>2</sub>	2995	495870	2-22	Ex nAC IIC T3/T4	8	9	2.1	8209
7	1250	2.5	10	10	-20	50	NBR	342N33 <sub>2</sub>	-	495905	1-21	Ex d mb IIC T4	8	8	2.1	8209	

#### Notes:

1. With captured exhaust
2. With manual override
3. A minimum current of 65 mA is required with this coil configuration

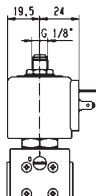
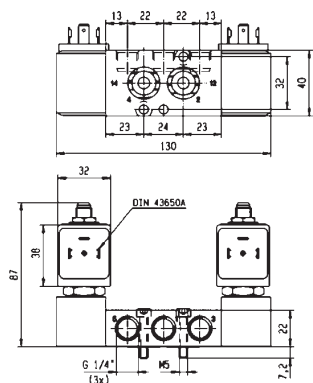

Drawing 8209



### 3 & 5 WAY PNEUMATIC DISTRIBUTORS



For this page	Port size	Orifice (mm)	Qn (l/min)	MOPD (bar)	Fluid Temp (°C)
From	1/8"-1/4"	4	400	10	-25
To	1/4"	7	1250	10	120

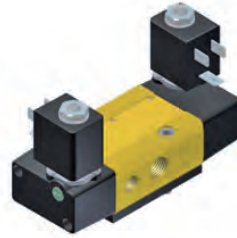
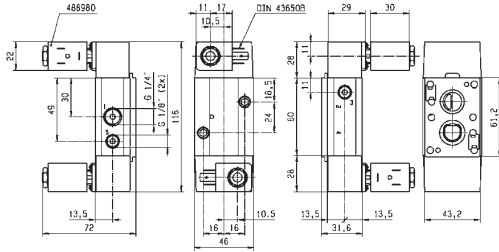

Drawing 7305

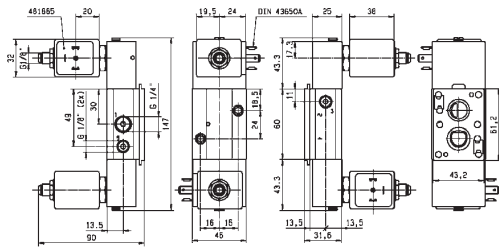

Drawing 7297

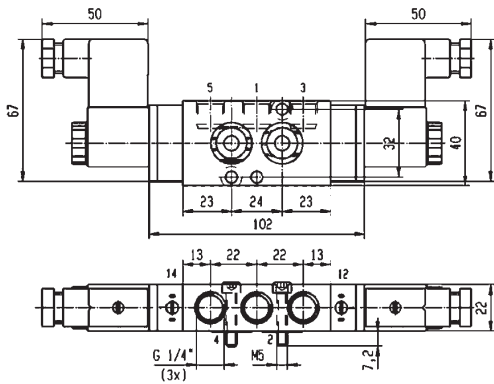

Drawing 8057



### 3 & 5 WAY PNEUMATIC DISTRIBUTORS

# 5/3

## 3 & 5 WAY PNEUMATIC VALVES FOR ACTUATOR CONTROL (NAMUR) PILOT OPERATED

ANODIZED ALUMINIUM

NAMUR

W3 EXHAUSTED IN CENTER POSITION

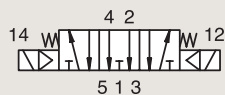

Port size	Orifice Ø	Flow factor	Operating Pressure Differential			Fluid Temp.		Seat Seal	Valve Ref.	Housing Ref.	Coil Ref.	ATEX Zone	Protection Mode	Power		Coil Group	Dwg. No.
			Min	Max (MOPD)	DC bar	Min	Max							AC W	DC W		
BSP	1	Qn l/min	bar	AC bar	DC bar	°C	°C										
	7	1250	3	10	10	-20	50	NBR	343N03 <sub>1</sub>	-	496131	-	-	3	3	1.2	8057
1/4"	7	1250	3	10	10	-20	50	NBR	343N03 <sub>1</sub>	-	496482	-	-	3	3	1.2	8057
	7	1250	3	10	10	-10	50	NBR	343N03 <sub>1</sub>	-	496637	22	Ex tD A22 IP65 - T95°C	3	3	1.2	8057

**Notes:**

1. With manual override

### 3 & 5 WAY PNEUMATIC DISTRIBUTORS



For this page	Port size	Orifice (mm)	Qn (l/min)	MOPD (bar)	Fluid Temp (°C)
From	1/4"	7	1250	10	-10
To	1/4"	7	1250	10	50

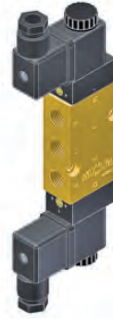
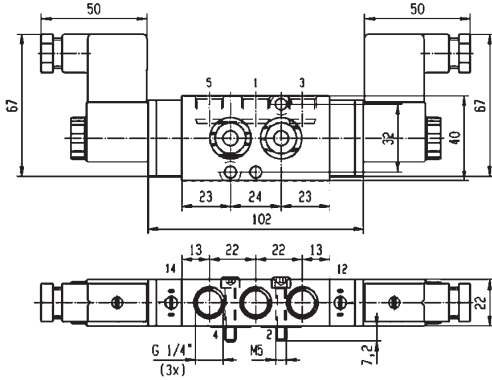

Drawing 8057

### 3 & 5 WAY PNEUMATIC DISTRIBUTORS

# 3/2-5/2

## 3 & 5 WAY PNEUMATIC VALVES FOR ACTUATOR CONTROL (NAMUR) PILOT OPERATED

ANODIZED ALUMINIUM

NAMUR

CONTROL BY ELECTRIC IMPULSE

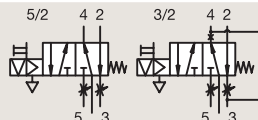

Port size	Orifice Ø	Flow factor	Operating Pressure Differential			Fluid Temp.		Seat Seal	Valve Ref.	Housing Ref.	Coil Ref.	ATEX Zone	Protection Mode	Power		Coil Group	Dwg. No.
			Min	Max (MOPD)	Min	Max	AC W							DC W			
BSP	mm	Qn l/min	bar	AC bar	DC bar	°C	°C										
1/8"-1/4"	4	600	2	-	10	-25	80	FKM/NBR	345N31 <sub>12</sub>	4269	485400	-	-	-	13	4.0	7295

Notes:

1. Pilot seat in FKM
2. With manual override

ANODIZED ALUMINIUM

NAMUR

SOLENOID OPERATED - SPRING RETURN

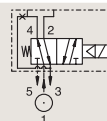

Port size	Orifice Ø	Flow factor	Operating Pressure Differential			Fluid Temp.		Seat Seal	Valve Ref.	Housing Ref.	Coil Ref.	ATEX Zone	Protection Mode	Power		Coil Group	Dwg. No.
			Min	Max (MOPD)	Min	Max	AC W							DC W			
BSP	mm	Qn l/min	bar	AC bar	DC bar	°C	°C										
1/8"-1/4"	4	355	1	10	10	-10	75	NBR	341L9504 <sub>12</sub>	-	482605	1-21	Ex mb IIC T4	4	5	1.1	7009
	4	355	1	10	10	-10	75	NBR	341L9504 <sub>12</sub>	-	482606	1-21	Ex mb IIC T4/T5	2	2.5	1.1	7009
	4	355	1	10	10	-10	75	NBR	341L9504 <sub>12</sub>	8993	488980	-	-	2	2.5	1.1	7009
	4	355	1	10	10	-10	75	NBR	341L9504 <sub>12</sub>	8993	495865	2-22	Ex nAC IIC T5	2	2.5	1.1	7009
	4	355	1	10	10	-10	75	NBR	341L9534 <sub>12</sub>	2995	481865	-	-	8	9	2.1/7.0	3990
	4	355	1	10	10	-10	75	NBR	341L9534 <sub>12</sub>	2995	495870	2-22	Ex nAC IIC T3/T4	8	9	2.1/7.0	3990
	4	355	1	10	10	-10	75	NBR	341L9534 <sub>12</sub>	-	495905	1-21	Ex d mb IIC T4	8	8	2.1/7.0	3990

Notes:

1. Pilot seat in FKM
2. With manual override



### 3 & 5 WAY PNEUMATIC DISTRIBUTORS



For this page	Port size	Orifice (mm)	Qn (l/min)	MOPD (bar)	Fluid Temp (°C)
From	1/8"-1/4"	4	355	10	-25
To	1/8"-1/4"	4	600	10	80

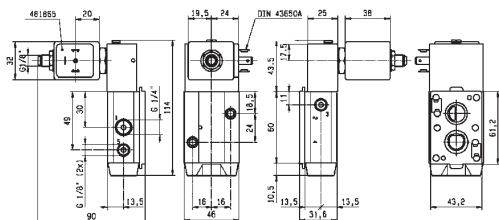

Drawing 7295

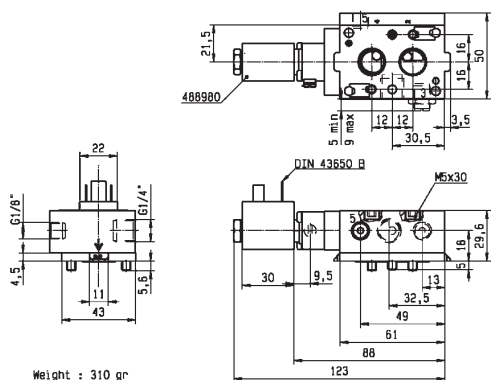

Weight : 310 gr



Drawing 7009

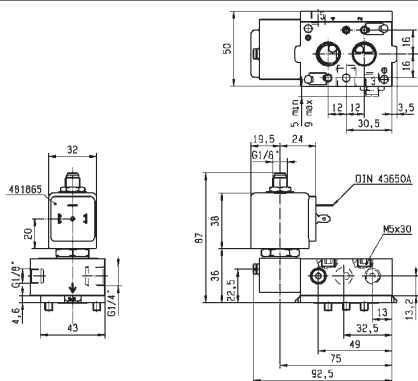

Drawing 3990



### 3 & 5 WAY PNEUMATIC DISTRIBUTORS

# 3/2-5/2

## 3 & 5 WAY PNEUMATIC VALVES FOR ACTUATOR CONTROL (NAMUR) PILOT OPERATED

### ANODIZED ALUMINIUM

### NAMUR

### SOLENOID OPERATED - SPRING RETURN

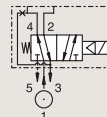

Port size BSP	Orifice Ø 1	Flow factor Qn l/min	Operating Pressure Differential			Fluid Temp.		Seat Seal	Valve Ref.	Housing Ref.	Coil Ref.	ATEX Zone	Protection Mode	Power		Coil Group	Dwg. No.
			Min	Max (MOPD) AC bar	DC bar	Min °C	Max °C							AC W	DC W		
1/8"- 1/4"	4	355	2	-	10	-10	55	NBR	341L9594 <sub>1</sub>	2995	483580.01	0-20	Ex ia IIC T6	-	0.5 to 3	7.0	3992
	4	355	1	-	10	-10	75	NBR	341L9594 <sub>1</sub>	-	495910	0-20	Ex ia IIC T4 to T6	-	0.3 to 3	7.0	3992
	4	355	2	-	10	-10	75	NBR/PUR	341L9597 <sub>2</sub>	2995	482740	-	-	-	1.6	6.0/8.0	8025
	4	355	2	10	10	-10	75	NBR/PUR	341L9597 <sub>2</sub>	-	495900	1-21	Ex d mb IIC T4 to T6	2.5	2	6.0/8.0	8025
	4	355	2	-	10	-10	75	NBR/PUR	341L9597 <sub>2</sub>	-	495910	0-20	Ex ia IIC T4 to T6	-	0.3 to 3	6.0/8.0	8025
	4	355	2	-	10	-10	75	NBR/PUR	341L9597 <sub>2</sub>	2995	496125	2-22	Ex nAC IIC T5/T6	-	1.6	6.0/8.0	8025
	4	355	2	-	10	-25	55	NBR/PUR	341L9598	2995	483580.01	0-20	Ex ia IIC T6	-	0.5 to 3	7.0	3992

**Notes:**

- 1.Pilot seat in FKM
- 2.With manual override



### 3 & 5 WAY PNEUMATIC DISTRIBUTORS

IECEX certified

UK CA

For this page	Port size	Orifice (mm)	Qn (l/min)	MOPD (bar)	Fluid Temp (°C)
From	1/8"-1/4"	4	355	10	-25
To	1/8"-1/4"	4	355	10	75

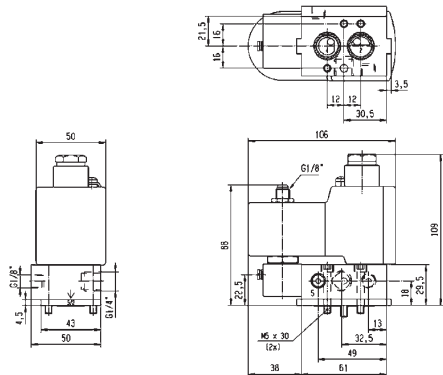

Drawing 3992

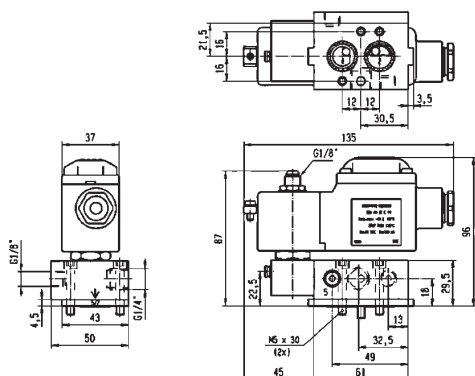

Drawing 8025

**3 & 5 WAY  
PNEUMATIC  
DISTRIBUTORS**

**3/2**

**3 & 5 WAY PNEUMATIC VALVES  
FOR ACTUATOR CONTROL (NAMUR)  
EXTERNALLY OPERATED**

**ANODIZED ALUMINIUM**

**NAMUR**

**AIR OPERATED - SPRING RETURN**

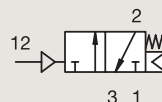

Port size	Orifice Ø	Flow factor	Operating Pressure Differential			Fluid Temp.		Seat Seal	Valve Ref.	Housing Ref.	Coil Ref.	ATEX Zone	Protection Mode	Power		Coil Group	Dwg. No.
			Min	Max (MOPD)	DC	Min	Max							AC	DC		
BSP	mm	Qn l/min	bar	AC bar	DC bar	°C	°C						W	W			
1/4"	7	1250	2.5	10	10	-10	50	NBR	531N03	-	-	-	-	-	-	-	8058
1/2"	12	3000	2.5	10	10	-10	50	NBR	531N04	-	-	-	-	-	-	-	8061



### 3 & 5 WAY PNEUMATIC DISTRIBUTORS



For this page	Port size	Orifice (mm)	Qn (l/min)	MOPD (bar)	Fluid Temp (°C)
From	1/4"	7	1250	10	-10
To	1/2"	12	3000	10	50

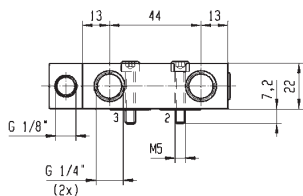
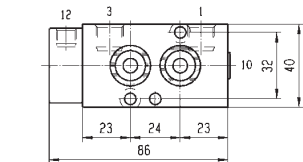

Drawing 8058

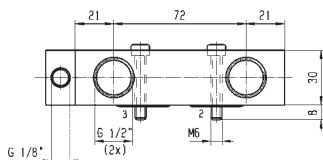
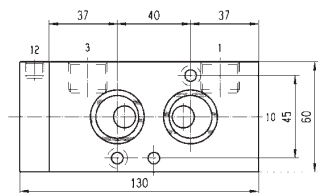

Drawing 8061

**3 & 5 WAY  
PNEUMATIC  
DISTRIBUTORS**

**3/2-5/2**

**3 & 5 WAY PNEUMATIC VALVES  
FOR ACTUATOR CONTROL (NAMUR)  
EXTERNALLY OPERATED**

**ANODIZED ALUMINIUM**

**NAMUR**

**AIR OPERATED - SPRING RETURN**

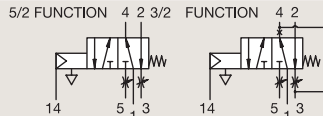

Port size	Orifice Ø	Flow factor	Operating Pressure Differential			Fluid Temp.		Seat Seal	Valve Ref.	Housing Ref.	Coil Ref.	ATEX Zone	Protection Mode	Power		Coil Group	Dwg. No.
			Min	Max (MOPD)	DC	Min	Max							AC	DC		
BSP	1	Qn l/min	bar	AC bar	DC bar	°C	°C							W	W		
1/8"- 1/4"	4	600	2	10	10	-40	50	NBR	541N0108	-	-	-	-	-	-	-	7309



### 3 & 5 WAY PNEUMATIC DISTRIBUTORS



For this page	Port size	Orifice (mm)	Qn (l/min)	MOPD (bar)	Fluid Temp (°C)
From	1/8"-1/4"	4	600	10	-40
To	1/8"-1/4"	4	600	10	80

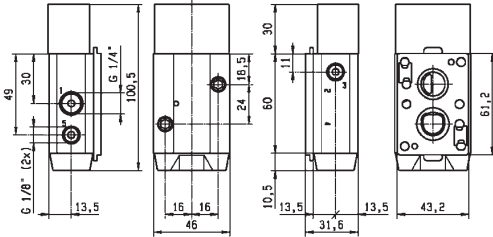

Drawing 7309

### 3 & 5 WAY PNEUMATIC DISTRIBUTORS

# 5/2

## 3 & 5 WAY PNEUMATIC VALVES FOR ACTUATOR CONTROL (NAMUR) EXTERNALLY OPERATED

### ANODIZED ALUMINIUM

#### NAMUR

#### AIR OPERATED - SPRING RETURN

5/2 FUNCTION

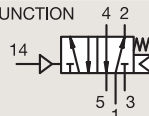

Port size	Orifice Ø	Flow factor	Operating Pressure Differential			Fluid Temp.		Seat Seal	Valve Ref.	Housing Ref.	Coil Ref.	ATEX Zone	Protection Mode	Power		Coil Group	Dwg. No.
			Min	Max (MOPD)	Min	Max	AC W							DC W			
BSP	mm	Qn l/min	bar	AC bar	DC bar	°C	°C										
1/4"	7	1250	2.5	10	10	-10	50	NBR	541N03	-	-	-	-	-	-	-	8064
1/2"	12	3000	2.5	10	10	-10	50	NBR	541N04	-	-	-	-	-	-	-	8066

### ANODIZED ALUMINIUM

#### NAMUR

#### AIR OPERATED AND RETURN

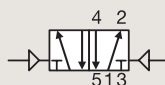

Port size	Orifice Ø	Flow factor	Operating Pressure Differential			Fluid Temp.		Seat Seal	Valve Ref.	Housing Ref.	Coil Ref.	ATEX Zone	Protection Mode	Power		Coil Group	Dwg. No.
			Min	Max (MOPD)	Min	Max	AC W							DC W			
BSP	mm	Qn l/min	bar	AC bar	DC bar	°C	°C										
1/4"	7	1250	2.5	10	10	-10	50	NBR	547N03	-	-	-	-	-	-	-	8059

### 3 & 5 WAY PNEUMATIC DISTRIBUTORS



For this page	Port size	Orifice (mm)	Qn (l/min)	MOPD (bar)	Fluid Temp (°C)
From	1/4"	7	1250	10	-10
To	1/2"	12	3000	10	50

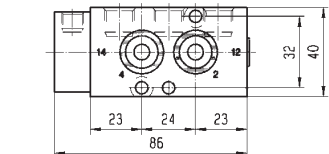

Drawing 8064

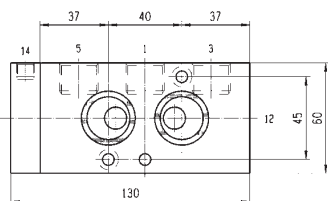
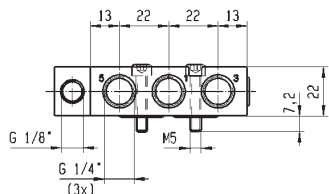

Drawing 8066

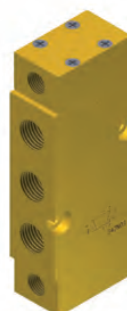
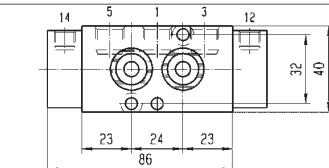
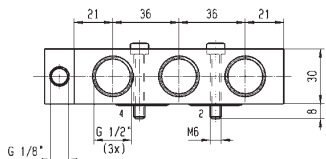

Drawing 8059

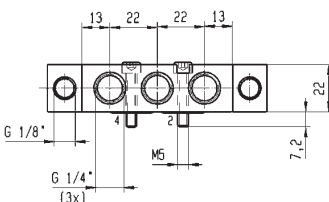

**3 & 5 WAY  
PNEUMATIC  
DISTRIBUTORS**

**5/3**

**3 & 5 WAY PNEUMATIC VALVES  
FOR ACTUATOR CONTROL (NAMUR)  
EXTERNALLY OPERATED**

**ANODIZED ALUMINIUM**

**NAMUR**

**W1 CLOSED CENTER POSITION**

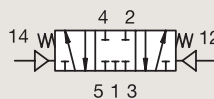

Port size	Orifice Ø	Flow factor	Operating Pressure Differential			Fluid Temp.		Seat Seal	Valve Ref.	Housing Ref.	Coil Ref.	ATEX Zone	Protection Mode	Power		Coil Group	Dwg. No.	
			Min	Max (MOPD)	DC	Min	Max							AC	DC			
BSP	mm	Qn l/min	bar	AC bar	DC bar	°C	°C							W	W			
1/4"	7	1250	2.5	10	10	-10	50	NBR	542N03	-	-	-	-	-	-	-	-	8059



### 3 & 5 WAY PNEUMATIC DISTRIBUTORS



For this page	Port size	Orifice (mm)	Qn (l/min)	MOPD (bar)	Fluid Temp (°C)
From	1/4"	7	1250	10	-10
To	1/4"	7	1250	10	50

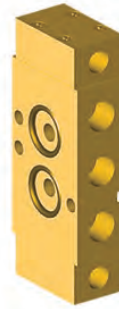
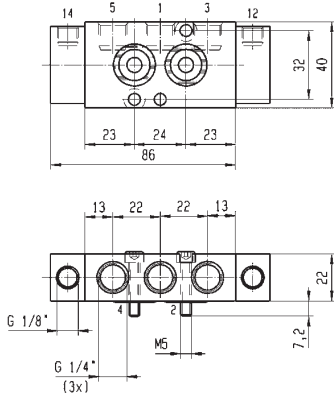

Drawing 8059



## 3 & 5 WAY PNEUMATIC DISTRIBUTORS FOR ACTUATION CONTROL



### 316L STAINLESS STEEL 3 & 5 WAY VALVES FOR ACTUATOR CONTROL (PIPE MOUNTING AND NAMUR)



**3/2**  
**5/2**

Actuation	Body	Function	Port Size	Orifice (mm)	Qn (l/min)	MOPD (bar)	Max Fluid Temp. (°C)	Page Parker Valves
Direct Operated	316L Stainless St./Pipe mounting	Universal	1/4"	2 to 6	680	12	75	350
			3/8"	6	680	10	75	358
	316L Stainless St./Sub-base mounting	Normally Closed	5 mm	2.5	220	12	14	360
		Universal	1/4"	6	680	10	65	360
Pilot Operated	316L Stainless St./NAMUR	Normally Closed	3/8"	6	680	10	75	362
	316L Stainless St./Pipe mounting	Normally Closed	3/8"	8	1400	10	80	364
		316L Stainless St./Pipe mounting/Spool	Normally Closed	3/8"	8	1400	10	80
	316L Stainless St./NAMUR/Spool	Dual Solenoids	3/8"	8	1400	10	80	368
		Normally Closed	3/8"-1/4"	8	1400	10	80	370
		Solenoid operated - spring return	3/8"-1/4"	8	1400	10	80	372
	Dual Solenoids	3/8"-1/4"	8	1400	10	80	374	
Manual Reset	316L Stainless St./Pipe mounting	Universal	1/4"	6	680	10	65	376
			3/8"	6	680	10	65	382

**3 & 5 WAY  
PNEUMATIC  
DISTRIBUTORS**

# 3/2

## 3 WAY VALVES DIRECT OPERATED

### V SERIES - STAINLESS STEEL VALVES FOR PIPE MOUNTING

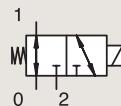
**316L STAINLESS ST.  
PIPE MOUNTING**

**UNIVERSAL**

Port size	Orifice Ø mm	Flow factor			Operating Pressure Differential Min Max(MOPD)		Fluid Temp.		Seat Seal	Valve Ref.	Housing Ref.	Coil Ref.	ATEX Zone	Protection Mode	Power		Coil Group	Dwg. No.	
		Kv l/min	KV m³/h	Qn l/min	AC bar	DC bar	Min °C	Max °C							AC W	DC W			
1/4" NPT	2	2.5	0.15	140	0	-	12	-25	65	FKM	U133V5595	-	496565	0-20	Ex ia IIC T4 to T6	-	0.3	9.0/10.1	8024
	2	2.5	0.15	140	0	12	12	-25	65	FKM	U133V5595	-	492310	1-21	Ex mb II T4 to T5	6	6	9.0/10.1	6713
	2	2.5	0.15	140	0	12	12	-25	65	FKM	U133V5595	-	496800	1-21	Ex db mb IIC T4	8	8	9.0/10.1	8024
	2	2.5	0.15	140	0	12	12	-25	65	FKM	U133V5595	-	496560	1-21	Ex db mb IIC T4	8	8	9.0/10.1	8024
	2	2.5	0.15	140	0	12	12	-25	50	FKM	U133V5595	-	496895	-	-	8	8	9.0/10.1	8024
	2	2.5	0.15	140	0	-	12	-25	65	FKM	U133V7595	-	496565	0-20	Ex ia IIC T4 to T6	-	0.3	9.0/10.1/10.3	8166
	2	2.5	0.15	140	0	12	12	-25	65	FKM	U133V7595	-	496800	1-21	Ex db mb IIC T4	8	8	9.0/10.1/10.3	8166
	2	2.5	0.15	140	0	12	12	-25	65	FKM	U133V7595	-	497105	1-21	Ex db IIC T4 to T6	8	8	9.0/10.1/10.3	8299
	2	2.5	0.15	140	0	12	12	-25	50	FKM	U133V7595	-	496895	-	-	8	8	9.0/10.1/10.3	8166
	2.5	3.5	0.21	220	0	-	8.5	-25	65	FKM	U133V5695	-	496565	0-20	Ex ia IIC T4 to T6	-	0.3	9.0/10.1	8024
	2.5	3.5	0.21	220	0	8.5	8.5	-25	75	FKM	U133V5695	-	492310	1-21	Ex mb II T4 to T5	6	6	9.0/10.1	6713
	2.5	3.5	0.21	220	0	8.5	8.5	-25	65	FKM	U133V5695	-	496800	1-21	Ex db mb IIC T4	8	8	9.0/10.1	8024
	2.5	3.5	0.21	220	0	8.5	8.5	-25	65	FKM	U133V5695	-	496560	1-21	Ex db mb IIC T4	8	8	9.0/10.1	8024
	2.5	3.5	0.21	220	0	8.5	8.5	-25	50	FKM	U133V5695	-	496895	-	-	8	8	9.0/10.1	8024
	2.5	3.5	0.21	220	0	-	8.5	-25	65	FKM	U133V7695	-	496565	0-20	Ex ia IIC T4 to T6	-	0.3	9.0/10.1/10.3	8166
	2.5	3.5	0.21	220	0	8.5	8.5	-25	65	FKM	U133V7695	-	496800	1-21	Ex db mb IIC T4	8	8	9.0/10.1/10.3	8166
2.5	3.5	0.21	220	0	8.5	8.5	-25	65	FKM	U133V7695	-	497105	1-21	Ex db IIC T4 to T6	8	8	9.0/10.1/10.3	8299	
2.5	3.5	0.21	220	0	8.5	8.5	-25	50	FKM	U133V7695	-	496895	-	-	8	8	9.0/10.1/10.3	8166	

**Notes:**

1. Valve delivered with an individual material traceability certificate (2.2 following EN10204)



### 3 & 5 WAY PNEUMATIC DISTRIBUTORS



For this page	Port size	Orifice (mm)	Qn (l/min)	MOPD (bar)	Fluid Temp (°C)
From	1/4"	2	140	8.5	-25
To	1/4"	2.5	220	12	75

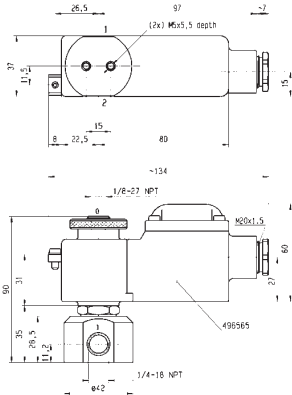

Drawing 8024

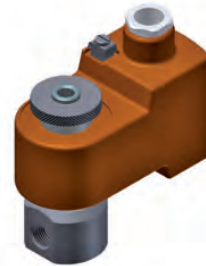
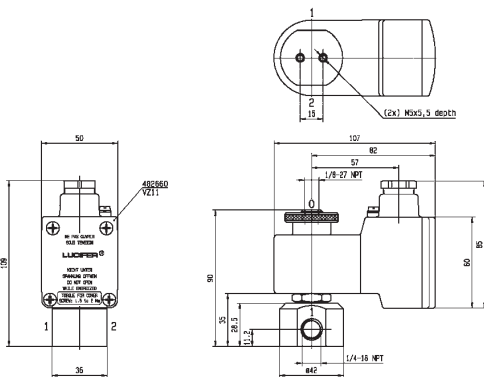

Drawing 6713

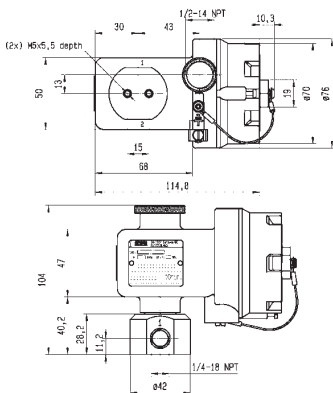

Drawing 8299



### 3 & 5 WAY PNEUMATIC DISTRIBUTORS

# 3/2

## 316L STAINLESS STEEL 3 & 5 WAY VALVES FOR ACTUATOR CONTROL (PIPE MOUNTING AND NAMUR) DIRECT OPERATED

### 316L STAINLESS ST. PIPE MOUNTING

### UNIVERSAL

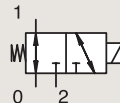

Port size	Orifice Ø	Flow factor	Operating Pressure Differential		Fluid Temp.		Seat Seal	Valve Ref.	Housing Ref.	Coil Ref.	ATEX Zone	Protection Mode	Power		Coil Group	Dwg. No.	
			Min	Max (MOPD)	Min	Max							AC W	DC W			
	1	Qn	Min	Max (MOPD)	Min	Max											
	mm	l/min	bar	AC bar	DC bar	°C	°C										
1/4" NPTF	6	680	0	12	12	-25	65	NBR	U133X5156 <sub>24</sub>	-	492965.01	0-20	Ex ia IIC T6	-	0.3 to 3	9.0/10.1/10.2	7770
	6	680	0	12	12	-25	65	NBR	U133X5156 <sub>24</sub>	-	496700	1-21	Ex d mb IIC T4 to T6	6	6	9.0/10.1/10.2	7770
	6	680	0	12	12	-25	65	NBR	U133X5196 <sub>2</sub>	-	492210	1-21	Ex e mb II T3 to T6	-	1.8	9.0/10.1/10.2	6904
	6	680	0	12	12	-25	65	NBR	U133X5196 <sub>2</sub>	-	492965.01	0-20	Ex ia IIC T6	-	0.3 to 3	9.0/10.1/10.2	6904
6	680	0	12	12	-25	65	NBR	U133X5196 <sub>2</sub>	-	496700	1-21	Ex d mb IIC T4 to T6	6	6	9.0/10.1/10.2	6904	

#### Notes:

- DC voltage only (or coil with rectifier). Minimum drop off voltage is 15% of nominal voltage (former DIN 19251)
- Valve delivered with an individual material traceability certificate (2.2 following EN10204)
- Valve only compatible with hydraulic oil and air/neutral gases
- With manual override

### 3 & 5 WAY PNEUMATIC DISTRIBUTORS



For this page	Port size	Orifice (mm)	Qn (l/min)	MOPD (bar)	Fluid Temp (°C)
From	1/4"	6	680	10	-25
To	1/4"	6	680	10	75

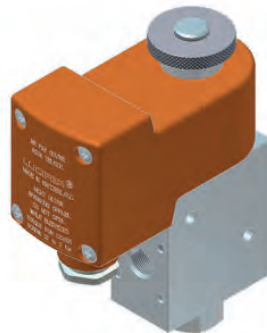
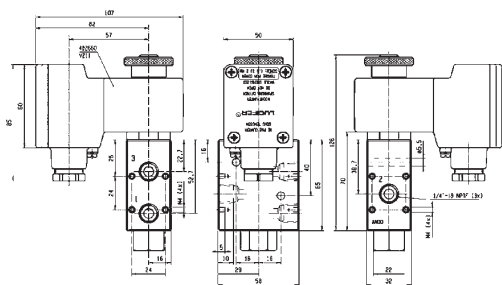

Drawing 7770

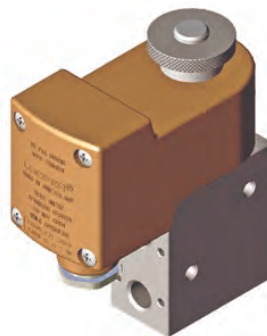
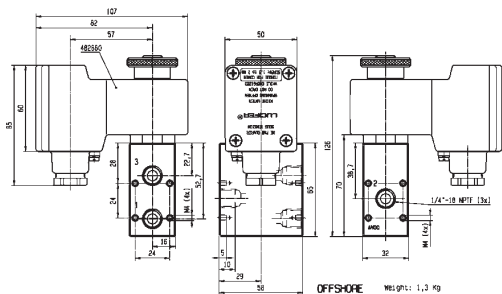

Drawing 6904

### 3 & 5 WAY PNEUMATIC DISTRIBUTORS

# 3/2

## 316L STAINLESS STEEL 3 & 5 WAY VALVES FOR ACTUATOR CONTROL (PIPE MOUNTING AND NAMUR) DIRECT OPERATED

### 316L STAINLESS ST. PIPE MOUNTING

#### UNIVERSAL

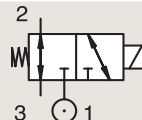

Port size	Orifice Ø	Flow factor	Operating Pressure Differential		Fluid Temp.		Seat Seal	Valve Ref.	Housing Ref.	Coil Ref.	ATEX Zone	Protection Mode	Power		Coil Group	Dwg. No.	
			Min	Max(MOPD)	Min	Max							AC W	DC W			
1/4" NPTF	6	680	0	12	-40	65	VMQ	U133X7759 <sub>1,2</sub>	-	496895	-	-	8	8	9.0/10.1/10.2/10.3	8544	
	6	680	0	-	-40	65	VMQ	U133X7759 <sub>1,2</sub>	-	496565	0-20	Ex ia IIC T4 to T6	-	0.3	9.0/10.1/10.2/10.3	8539	
	6	680	0	12	12	-40	65	VMQ	U133X7759 <sub>1,2</sub>	-	497105	1-21	Ex db IIC T4 to T6	8	8	9.0/10.1/10.2/10.3	8537
	6	680	0	12	12	-40	65	VMQ	U133X7759 <sub>1,2</sub>	-	496700	1-21	Ex db mb IIC T4 to T6	6	6	9.0/10.1/10.2/10.3	8545
	6	680	0	12	12	-40	65	VMQ	U133X7759 <sub>1,2</sub>	-	492310	1-21	Ex mb II T4 to T5	9	8	9.0/10.1/10.2/10.3	8546
	6	680	0	-	12	-40	65	VMQ	U133X7759 <sub>1,2</sub>	-	492210	1-21	Ex eb mb IIC T5 to T6	-	1.8	9.0/10.1/10.2/10.3	8546
	6	680	0	12	12	-40	65	VMQ	U133X7709 <sub>1</sub>	-	496895	-	-	8	8	9.0/10.1/10.2/10.3	8551
	6	680	0	-	12	-40	65	VMQ	U133X7709 <sub>1</sub>	-	496565	0-20	Ex ia IIC T4 to T6	-	0.3	9.0/10.1/10.2/10.3	8550
	6	680	0	12	12	-40	65	VMQ	U133X7709 <sub>1</sub>	-	497105	1-21	Ex db IIC T4 to T6	8	8	9.0/10.1/10.2/10.3	8538
	6	680	0	12	12	-40	65	VMQ	U133X7709 <sub>1</sub>	-	496700	1-21	Ex db mb IIC T4 to T6	6	6	9.0/10.1/10.2/10.3	8549
6	680	0	12	12	-40	65	VMQ	U133X7709 <sub>1</sub>	-	492310	1-21	Ex mb II T4 to T5	9	8	9.0/10.1/10.2/10.3	8548	
6	680	0	-	12	-40	65	VMQ	U133X7709 <sub>1</sub>	-	492210	1-21	Ex eb mb IIC T5 to T6	-	1.8	9.0/10.1/10.2/10.3	8548	

#### Notes:

1. Valve delivered with an individual material traceability certificate (2.2 following EN10204)
2. With manual override

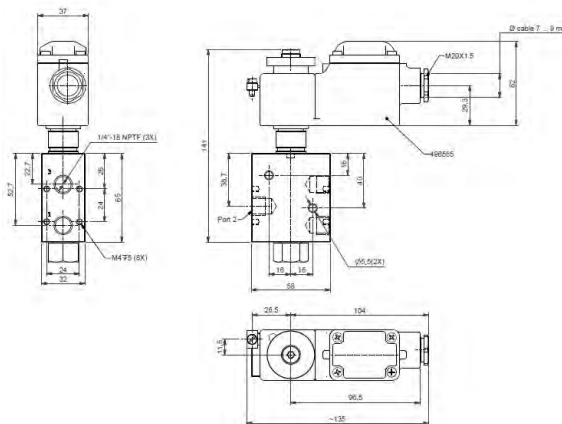

Drawing 8539

### 3 & 5 WAY PNEUMATIC DISTRIBUTORS



For this page	Port size	Orifice (mm)	Qn (l/min)	MOPD (bar)	Fluid Temp (°C)
From	1/4"	6	680	12	-25
To	1/4"	6	680	12	65

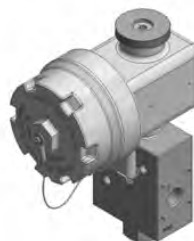
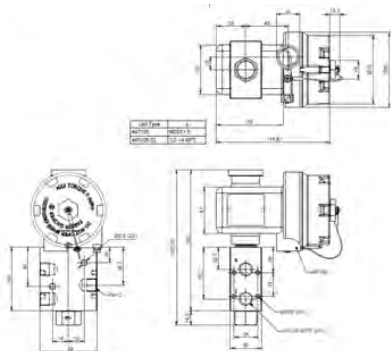

Drawing 8537

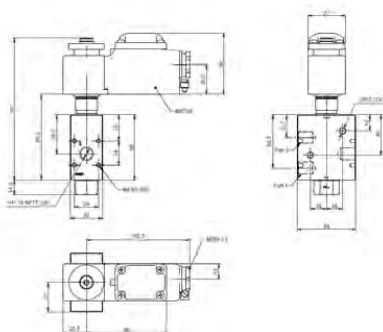

Drawing 8545

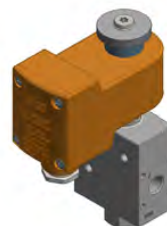
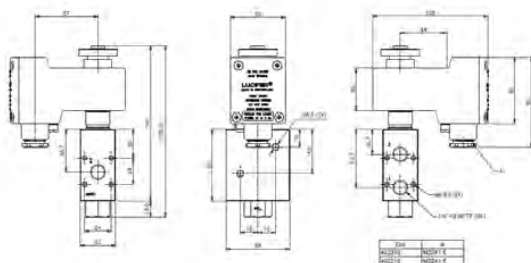

Drawing 8546



**3 & 5 WAY  
PNEUMATIC  
DISTRIBUTORS**

**3/2**

**316L STAINLESS STEEL 3 & 5 WAY VALVES  
FOR ACTUATOR CONTROL (PIPE MOUNTING AND NAMUR)**

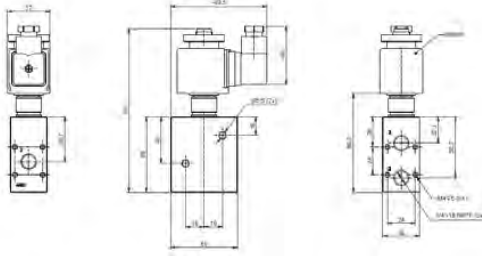

Drawing 8551

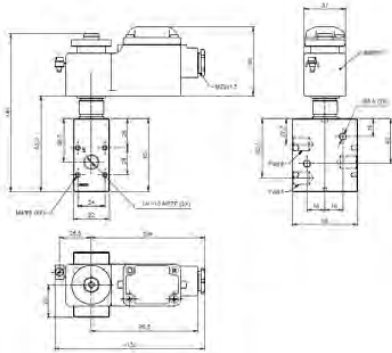

Drawing 8550

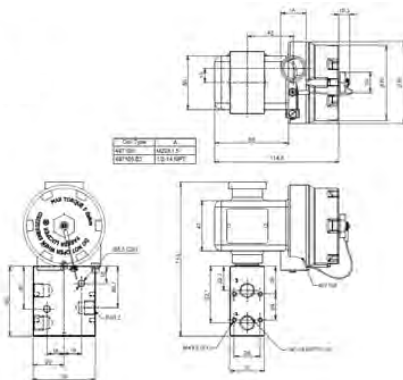

Drawing 8538



### 3 & 5 WAY PNEUMATIC DISTRIBUTORS



For this page	Port size	Orifice (mm)	Qn (l/min)	MOPD (bar)	Fluid Temp (°C)
From	1/4"	6	680	10	-25
To	1/4"	6	680	10	65

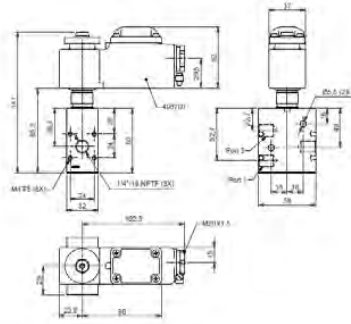

Drawing 8549

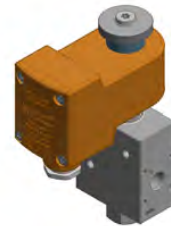
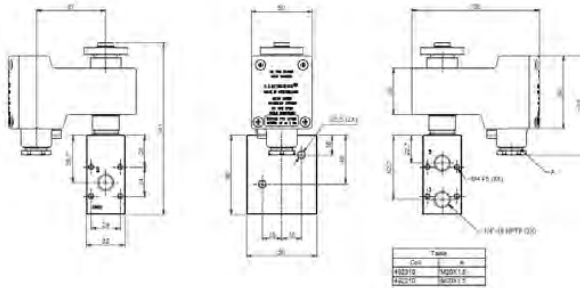

Drawing 8548

**3 & 5 WAY  
PNEUMATIC  
DISTRIBUTORS**

# 3/2

## 316L STAINLESS STEEL 3 & 5 WAY VALVES FOR ACTUATOR CONTROL (PIPE MOUNTING AND NAMUR) DIRECT OPERATED

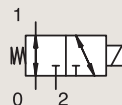
**316L STAINLESS ST.  
PIPE MOUNTING**

**UNIVERSAL**

Port size	Orifice Ø 1	Flow factor Qn l/min	Operating Pressure Differential		Fluid Temp.		Seat Seal	Valve Ref.	Housing Ref.	Coil Ref.	ATEX Zone	Protection Mode	Power		Coil Group	Dwg. No.
			Min bar	Max (MOPD) AC bar DC bar	Min °C	Max °C							AC W	DC W		
3/8" NPTF	6	680	0	12 12	-25 75	NBR	U133X5296	-	492310	1-21	Ex e mb II T3 to T6	6	6	9.0/10.1/10.2	7669	
	6	680	0	12 12	-25 65	NBR	U133X5296	-	492965.01	0-20	Ex ia IIC T6	-	0.3 to 3	9.0/10.1/10.2	7669	
	6	680	0	12 12	-25 65	NBR	U133X5296	-	496700	1-21	Ex d mb IIC T4 to T6	6	6	9.0/10.1/10.2	7669	

**Notes:**

1. Valve delivered with an individual material traceability certificate (2.2 following EN10204)

### 3 & 5 WAY PNEUMATIC DISTRIBUTORS



For this page	Port size	Orifice (mm)	Qn (l/min)	MOPD (bar)	Fluid Temp (°C)
From	3/8"	6	680	10	-25
To	3/8"	6	680	10	75

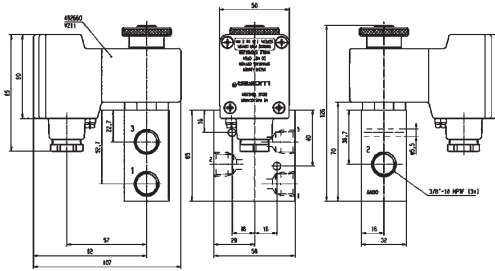

Drawing 7669

### 3 & 5 WAY PNEUMATIC DISTRIBUTORS

# 3/2

## 316L STAINLESS STEEL 3 & 5 WAY VALVES FOR ACTUATOR CONTROL (PIPE MOUNTING AND NAMUR) DIRECT OPERATED

### 316L STAINLESS ST.

#### SUB-BASE MOUNTING

#### NORMALLY CLOSED

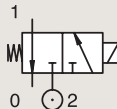

Port size	Orifice Ø mm	Flow factor		Operating Pressure Differential		Fluid Temp.		Seat Seal	Valve Ref.	Housing Ref.	Coil Ref.	ATEX Zone	Protection Mode	Power		Coil Group	Dwg. No.	
		Kv l/min	KV m³/h	Qn l/min	Min AC bar	Max DC bar	Min °C							Max °C	AC W			DC W
SB	2.5	3.5	0.21	220	0	-	12	-25 75	FKM	U131F5295	-	496565	0-20	Ex ia IIC T4 to T6	-	0.3	9.0/10.1/10.2	8174
	2.5	3.5	0.21	220	0	12	12	-25 65	FKM	U131F5295	-	496800	1-21	Ex db mb IIC T4	8	8	9.0/10.1/10.2	8174
	2.5	3.5	0.21	220	0	12	12	-25 65	FKM	U131F5295	-	496560	1-21	Ex db mb IIC T4	8	8	9.0/10.1/10.2	8174
	2.5	3.5	0.21	220	0	-	12	-25 75	FKM	U131F5295	-	492210	1-21	Ex eb mb IIC T5 to T6	-	1 to 1.8	9.0/10.1/10.2	8343
	2.5	3.5	0.21	220	0	12	12	-25 75	FKM	U131F5295	-	492310	1-21	Ex mb II T4 to T5	6	6	9.0/10.1/10.2	8343
	2.5	3.5	0.21	220	0	12	12	-25 50	FKM	U131F5295	-	496895	-	-	8	8	9.0/10.1/10.2	8174
	2.5	3.5	0.21	220	0	-	12	-25 50	FKM	U131F7695	-	496565	0-20	Ex ia IIC T4 to T6	-	0.3	9.0/10.1/10.2/10.3	8174
	2.5	3.5	0.21	220	0	12	12	-25 75	FKM	U131F7695	-	497105	1-21	Ex db IIC T4 to T6	8	8	9.0/10.1/10.2/10.3	8302
	2.5	3.5	0.21	220	0	12	12	-25 65	FKM	U131F7695	-	496800	1-21	Ex db mb IIC T4	8	8	9.0/10.1/10.2/10.3	8174
	2.5	3.5	0.21	220	0	12	12	-25 50	FKM	U131F7695	-	496895	-	-	8	8	9.0/10.1/10.2/10.3	8174

**Notes:**

1. Valve only compatible with air and neutral gases

### 316L STAINLESS ST.

#### SUB-BASE MOUNTING

#### UNIVERSAL

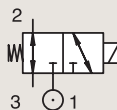

Port size	Orifice Ø mm	Flow factor		Operating Pressure Differential		Fluid Temp.		Seat Seal	Valve Ref.	Housing Ref.	Coil Ref.	ATEX Zone	Protection Mode	Power		Coil Group	Dwg. No.
		1 Qn l/min	Min bar	Max (MOPD) DC bar	Min °C	Max °C	AC W							DC W			
1/4" NPTF	6	680	0	12	12	-25	65	FKM	U133X5195	-	492310	1-21	Ex e mb II T3 to T6	6	6	9.0/10.1/10.2	3572
	6	680	0	12	12	-25	65	FKM	U133X5195	-	496700	1-21	Ex d mb IIC T4 to T6	6	6	9.0/10.1/10.2	3572

**Notes:**

1. Valve delivered with an individual material traceability certificate (2.2 following EN10204)

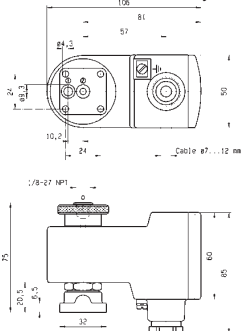

Drawing 8343



### 3 & 5 WAY PNEUMATIC DISTRIBUTORS



For this page	Port size	Orifice (mm)	Qn (l/min)	MOPD (bar)	Fluid Temp (°C)
From	SB	2.5	220	10	-25
To	SB	6	680	14	80

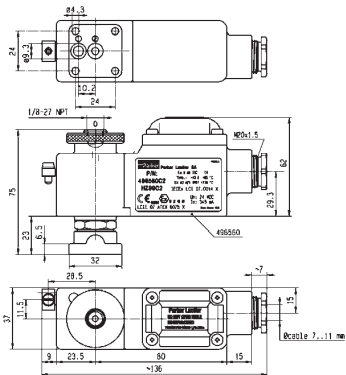

Drawing 8174

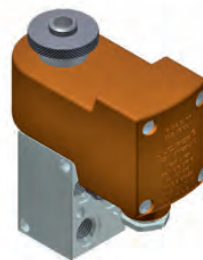
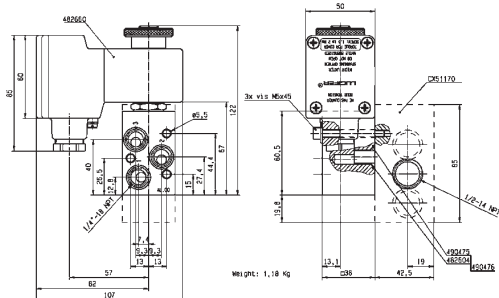

Drawing 3572

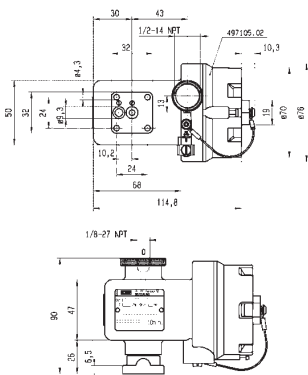

Drawing 8302



### 3 & 5 WAY PNEUMATIC DISTRIBUTORS

# 3/2

## 316L STAINLESS STEEL 3 & 5 WAY VALVES FOR ACTUATOR CONTROL (PIPE MOUNTING AND NAMUR) DIRECT OPERATED

### 316L STAINLESS ST. SUB-BASE MOUNTING

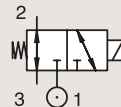

#### UNIVERSAL

Port size	Orifice Ø 1	Flow factor Qn l/min	Operating Pressure Differential		Fluid Temp.		Seat Seal	Valve Ref.	Housing Ref.	Coil Ref.	ATEX Zone	Protection Mode	Power		Coil Group	Dwg. No.	
			Min	Max (MOPD) AC bar DC bar	Min	Max							AC W	DC W			
1/4" NPTF	6	680	0	12	12	-25	65	FKM	U133X7195	-	492210	1-21	Ex e mb II T3 to T6	-	1.8	9.0/10.1/10.2	8172
	6	680	0	12	12	-25	65	FKM	U133X7195	-	492965.01	0-20	Ex ia IIC T6	-	0.3 to 3	9.0/10.1/10.2	8172
	6	680	0	12	12	-25	65	FKM	U133X7195	-	496700	1-21	Ex d mb IIC T4 to T6	6	6	9.0/10.1/10.2	8172

### 316L STAINLESS ST. NAMUR

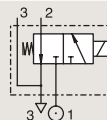

#### NORMALLY CLOSED

Port size	Orifice Ø 1	Flow factor Qn l/min	Operating Pressure Differential		Fluid Temp.		Seat Seal	Valve Ref.	Housing Ref.	Coil Ref.	ATEX Zone	Protection Mode	Power		Coil Group	Dwg. No.	
			Min	Max (MOPD) AC bar DC bar	Min	Max							AC W	DC W			
3/8" NPT	6	680	0	12	12	-25	65	NBR	U131X1201	-	492310	1-21	Ex e mb II T3 to T6	6	6	9.0/10.1/10.2	7668
	6	680	0	12	12	-25	75	NBR	U131X1201	-	492965.01	0-20	Ex ia IIC T6	-	0.3 to 3	9.0/10.1/10.2	7668
	6	680	0	12	12	-25	65	NBR	U131X1201	-	496700	1-21	Ex d mb IIC T4 to T6	6	6	9.0/10.1/10.2	7668

**Notes:**

1. Valve delivered with an individual material traceability certificate (2.2 following EN10204)



### 3 & 5 WAY PNEUMATIC DISTRIBUTORS



For this page	Port size	Orifice (mm)	Qn (l/min)	MOPD (bar)	Fluid Temp (°C)
From	1/4"	6	680	10	-25
To	3/8"	6	680	10	75

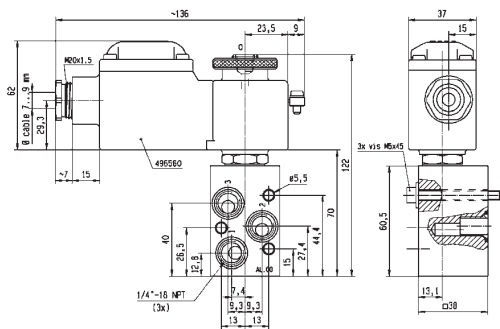

Drawing 8172

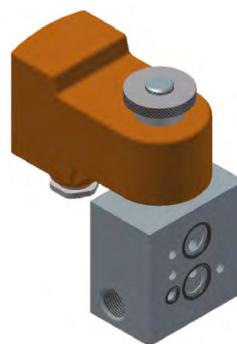
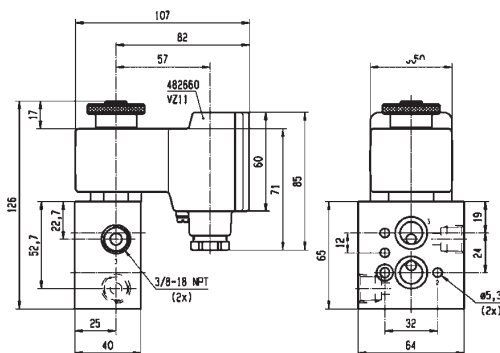

Drawing 7668



### 3 & 5 WAY PNEUMATIC DISTRIBUTORS

# 5/2

## 316L STAINLESS STEEL 3 & 5 WAY VALVES FOR ACTUATOR CONTROL (PIPE MOUNTING AND NAMUR) PILOT OPERATED



Process

### 316L STAINLESS ST. PIPE MOUNTING

#### NORMALLY CLOSED

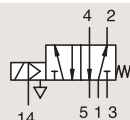

Port size	Orifice Ø 1 mm	Flow factor Qn l/min	Operating Pressure Differential		Fluid Temp.		Seat Seal	Valve Ref.	Housing Ref.	Coil Ref.	ATEX Zone	Protection Mode	Power		Coil Group	Dwg. No.
			Min	Max (MOPD) AC bar DC bar	Min	Max							AC W	DC W		
3/8" NPT	8	1400	2	10 10	-25	80	NBR	U441P3250 <sub>12</sub>	4270	481000	-	-	8	8	2.1	7565
	8	1400	2	10 10	-25	80	NBR	U441P3250 <sub>12</sub>	2995	481865	-	-	8	9	2.1	7565

Notes:

1. Pilot seat in FKM
2. Valve with external pilot pressure minimum 4 bar

### 316L STAINLESS ST. PIPE MOUNTING

#### NORMALLY CLOSED

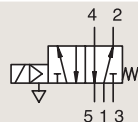

Port size	Orifice Ø 1 mm	Flow factor Qn l/min	Operating Pressure Differential		Fluid Temp.		Seat Seal	Valve Ref.	Housing Ref.	Coil Ref.	ATEX Zone	Protection Mode	Power		Coil Group	Dwg. No.
			Min	Max (MOPD) AC bar DC bar	Min	Max							AC W	DC W		
3/8" NPT	8	1400	2	10 10	-25	80	NBR	U341P0250 <sub>123</sub>	8993	481045	-	-	2	2.5	1.1	7578
	8	1400	2	10 10	-25	80	NBR	U341P0250 <sub>123</sub>	-	482606	1-21	Ex mb IIC T4/T5	2	2.5	1.1	7578
1/4" NPT	8	1400	2	10 10	-25	80	NBR	U341P3250 <sub>1</sub>	4270	481000	-	-	8	8	2.1	7558
	8	1400	2	10 10	-25	80	NBR	U341P3250 <sub>1</sub>	2995	481865	-	-	8	9	2.1	7558
	8	1400	2	10 10	-25	80	NBR	U341P3250 <sub>1</sub>	2995	492453	-	-	8	9	2.1	7558

Notes:

1. Pilot seat in FKM
2. With captured exhaust
3. With manual override



### 3 & 5 WAY PNEUMATIC DISTRIBUTORS



For this page	Port size	Orifice (mm)	Qn (l/min)	MOPD (bar)	Fluid Temp (°C)
From	3/8"	8	1400	10	-25
To	3/8"	8	1400	10	80

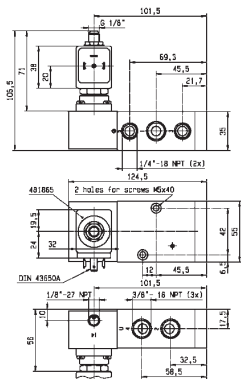

Drawing 7565

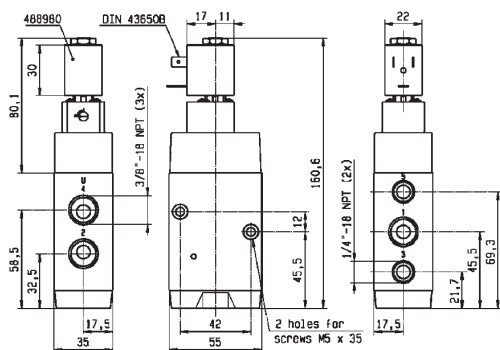

Drawing 7578

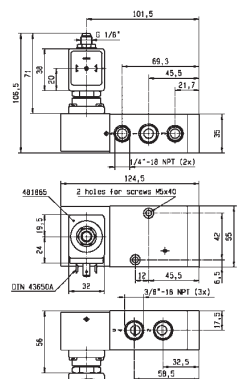

Drawing 7558



**3 & 5 WAY  
PNEUMATIC  
DISTRIBUTORS**

**5/2**

**316L STAINLESS STEEL 3 & 5 WAY VALVES  
FOR ACTUATOR CONTROL (PIPE MOUNTING AND NAMUR)  
PILOT OPERATED**

**316L STAINLESS ST.  
PIPE MOUNTING**

**NORMALLY CLOSED**

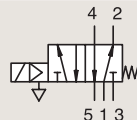

Port size	Orifice Ø 1	Flow factor Qn l/min	Operating Pressure Differential			Fluid Temp.		Seat Seal	Valve Ref.	Housing Ref.	Coil Ref.	ATEX Zone	Protection Mode	Power		Coil Group	Dwg. No.
			Min	Max (MOPD)	DC	Min	Max							AC W	DC W		
3/8" NPT	8	1400	2	-	10	-25	55	NBR	U341P3292	2995	483580.01	0-20	Ex ia IIC T6	-	0.5 to 3	7.0	7560
	8	1400	2	10	10	-25	75	NBR	U341P3295	-	492310	1-21	Ex e mb II T3 to T6	6	6	9.0/10.1	7561
	8	1400	2	-	10	-25	75	NBR	U341P3295	-	492965.01	0-20	Ex ia IIC T6	-	0.3 to 3	9.0/10.1	7561



### 3 & 5 WAY PNEUMATIC DISTRIBUTORS



For this page	Port size	Orifice (mm)	Qn (l/min)	MOPD (bar)	Fluid Temp (°C)
From	3/8"	8	1400	10	-25
To	3/8"	8	1400	10	75

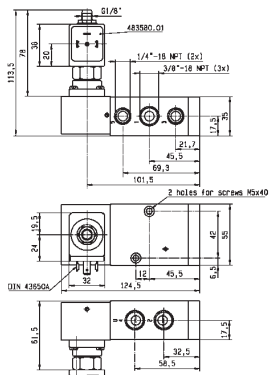

Drawing 7560

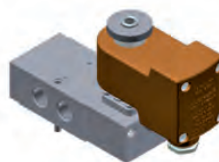
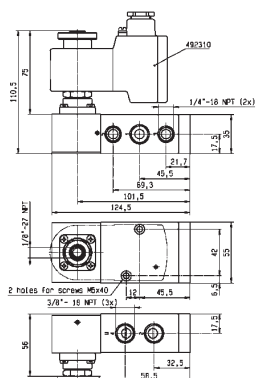

Drawing 7561

**3 & 5 WAY  
PNEUMATIC  
DISTRIBUTORS**

**5/2**

**316L STAINLESS STEEL 3 & 5 WAY VALVES  
FOR ACTUATOR CONTROL (PIPE MOUNTING AND NAMUR)  
PILOT OPERATED**

**316L STAINLESS ST.  
PIPE MOUNTING**

**DUAL SOLENOIDS**

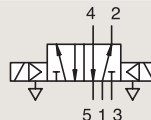

Port size	Orifice Ø 1	Flow factor Qn l/min	Operating Pressure Differential			Fluid Temp.		Seat Seal	Valve Ref.	Housing Ref.	Coil Ref.	ATEX Zone	Protection Mode	Power		Coil Group	Dwg. No.
			Min	Max (MOPD) AC bar	DC bar	Min	Max							AC W	DC W		
3/8" NPT	8	1400	2	10	10	-25	80	NBR	U347P3250	4270	481000	-	-	8	8	2.1	7563
	8	1400	2	10	10	-25	80	NBR	U347P3250	-	483371	1-21	Ex e mb IIC T4	8	8	2.1	7563
	8	1400	2	10	10	-25	75	NBR	U347P3295	-	492310	1-21	Ex e mb II T3 to T6	6	6	10.1	7564
	8	1400	2	10	10	-25	75	NBR	U347P3295	-	496800	1-21	Ex d mb IIC T4	8	8	10.1	7564

**Notes:**

1.Pilot seat in FKM



### 3 & 5 WAY PNEUMATIC DISTRIBUTORS



For this page	Port size	Orifice (mm)	Qn (l/min)	MOPD (bar)	Fluid Temp (°C)
From	3/8"	8	1400	10	-25
To	3/8"	8	1400	10	80

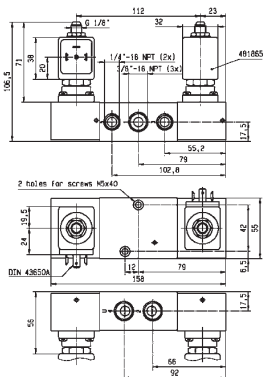

Drawing 7563

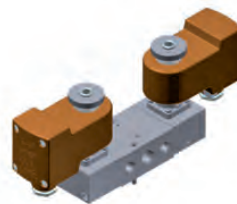
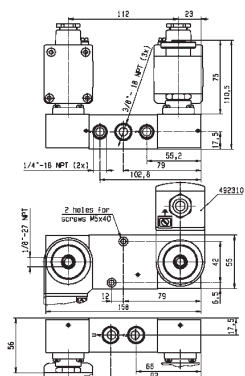

Drawing 7564

### 3 & 5 WAY PNEUMATIC DISTRIBUTORS

# 3/2-5/2

## 316L STAINLESS STEEL 3 & 5 WAY VALVES FOR ACTUATOR CONTROL (PIPE MOUNTING AND NAMUR) PILOT OPERATED

### 316L STAINLESS ST.

### NAMUR

### NORMALLY CLOSED

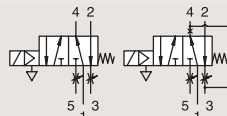

Port size	Orifice Ø	Flow factor	Operating Pressure Differential			Fluid Temp.		Seat Seal	Valve Ref.	Housing Ref.	Coil Ref.	ATEX Zone	Protection Mode		Power		Coil Group	Dwg. No.
			Min	Max (MOPD)	DC bar	Min	Max						AC W	DC W				
3/8"- 1/4" NPT	8	1400	2	10	10	-25	80	NBR	U341N3250	2995	481865	-	-	8	9	2.1	7554	
	8	1400	2	10	10	-25	80	NBR	U341N3250	-	492190	1-21	Ex e mb IIC T3/T4	11	9	2.1	7554	
	8	1400	2	-	10	-25	55	NBR	U341N3292	2995	483580.01	0-20	Ex ia IIC T6	-	0.5	7.0	7556	
	8	1400	2	10	10	-25	75	NBR	U341N3295	-	492310	1-21	Ex e mb II T3 to T6	6	6	10.1	7696	
	8	1400	2	10	10	-25	75	NBR	U341N3295	-	496800	1-21	Ex d mb IIC T4	8	8	10.1	7696	

#### Notes:

1. Pilot seat in FKM
2. With captured exhaust
3. With manual override

### 3 & 5 WAY PNEUMATIC DISTRIBUTORS



For this page	Port size	Orifice (mm)	Qn (l/min)	MOPD (bar)	Fluid Temp (°C)
From	3/8"-1/4"	8	1400	10	-25
To	3/8"-1/4"	8	1400	10	80

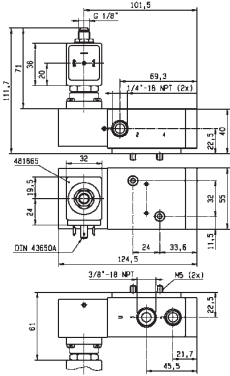

Drawing 7554

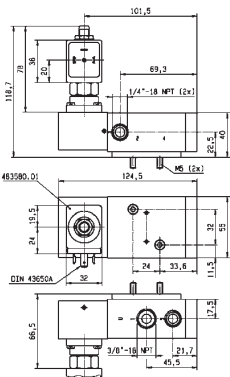

Drawing 7556

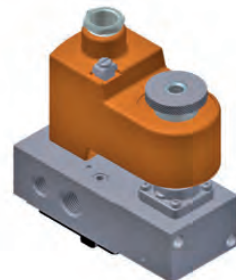
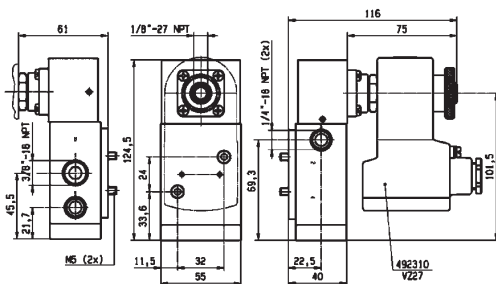

Drawing 7696



**3 & 5 WAY  
PNEUMATIC  
DISTRIBUTORS**

**3/2-5/2**

**316L STAINLESS STEEL 3 & 5 WAY VALVES  
FOR ACTUATOR CONTROL (PIPE MOUNTING AND NAMUR)  
PILOT OPERATED**

**316L STAINLESS ST.**

**NAMUR**

**SOLENOID OPERATED - SPRING RETURN**

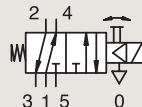

Port size	Orifice Ø 1 mm	Flow factor Qn l/min	Operating Pressure Differential			Fluid Temp.		Seat Seal	Valve Ref.	Housing Ref.	Coil Ref.	ATEX Zone	Protection Mode	Power		Coil Group	Dwg. No.
			Min	Max (MOPD) AC bar	DC bar	Min °C	Max °C							AC W	DC W		
3/8"	8	1400	2	10	10	-25	80	NBR	U341N0250 <sub>123</sub>	-	482606	1-21	Ex mb IIC T4/T5	2	2.5	1.1	7577
1/4" NPT	8	1400	2	10	10	-25	80	NBR	U341N0250 <sub>123</sub>	8993	488980	-	-	2	2.5	1.1	7577

**Notes:**

1. Pilot seat in FKM
2. With captured exhaust
3. With manual override



### 3 & 5 WAY PNEUMATIC DISTRIBUTORS



For this page	Port size	Orifice (mm)	Qn (l/min)	MOPD (bar)	Fluid Temp (°C)
From	3/8"-1/4"	8	1400	10	-25
To	3/8"-1/4"	8	1400	10	80

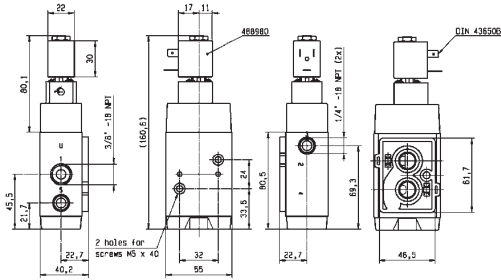

Drawing 7577



**3 & 5 WAY  
PNEUMATIC  
DISTRIBUTORS**

# 5/2

## 316L STAINLESS STEEL 3 & 5 WAY VALVES FOR ACTUATOR CONTROL (PIPE MOUNTING AND NAMUR) PILOT OPERATED

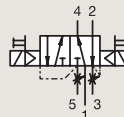
**316L STAINLESS ST.**
**NAMUR**
**DUAL SOLENOIDS**

Port size	Orifice Ø 1 mm	Flow factor Qn l/min	Operating Pressure Differential			Fluid Temp.		Seat Seal	Valve Ref.	Housing Ref.	Coil Ref.	ATEX Zone	Protection Mode	Power		Coil Group	Dwg. No.
			Min	Max (MOPD)	DC	Min	Max							AC W	DC W		
3/8"- 1/4"NPT	8	1400	2	10	10	-25	80	NBR	U347N3250	4270	481000	-	-	8	8	2.1	7557
	8	1400	2	10	10	-25	80	NBR	U347N3250	2995	481865	-	-	8	9	2.1	7557

**Notes:**

1. Pilot seat in FKM

### 3 & 5 WAY PNEUMATIC DISTRIBUTORS



For this page	Port size	Orifice (mm)	Qn (l/min)	MOPD (bar)	Fluid Temp (°C)
From	3/8"-1/4"	8	1400	10	-25
To	3/8"-1/4"	8	1400	10	80

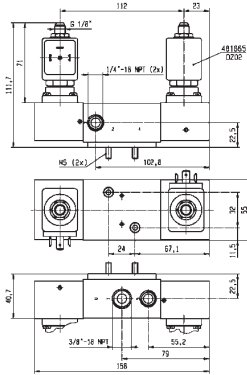

Drawing 7557

### 3 & 5 WAY PNEUMATIC DISTRIBUTORS

# 3/2

## 316L STAINLESS STEEL 3 & 5 WAY VALVES FOR ACTUATOR CONTROL (PIPE MOUNTING AND NAMUR) MANUAL RESET



Process

### 316L STAINLESS ST. PIPE MOUNTING

#### UNIVERSAL

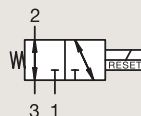

Port size	Orifice Ø	Flow factor	Operating Pressure Differential		Fluid Temp.		Seat Seal	Valve Ref.	Housing Ref.	Coil Ref.	ATEX Zone	Protection Mode	Power		Coil Group	Dwg. No.
			Min	Max (MOPD)	Min	Max							AC W	DC W		
1/4" NPTF	6	680	0	- 10	-25	65	NBR	U033X5156 <sub>1</sub>	-	482870.01	0-20	Ex ia IIC T6	-	0.3 to 3	10.1/10.2/12.0	7771
	6	680	0	10	-25	65	NBR	U033X5156 <sub>1</sub>	-	492310	1-21	Ex e mb II T3 to T6	6	6	10.1/10.2/12.0	7771
	6	680	0	- 10	-25	65	NBR	U033X5156 <sub>1</sub>	-	492335	0-20	NEMA 4-4X	-	0.3 to 3	10.1/10.2/12.0	7771
	6	680	0	10	-25	65	NBR	U033X5156 <sub>1</sub>	-	496700	1-21	Ex d mb IIC T4 to T6	6	6	10.1/10.2/12.0	7771

Notes:

1. Valve delivered with an individual material traceability certificate (2.2 following EN10204)



### 3 & 5 WAY PNEUMATIC DISTRIBUTORS



For this page	Port size	Orifice (mm)	Qn (l/min)	MOPD (bar)	Fluid Temp (°C)
From	1/4"	6	680	10	-25
To	1/4"	6	680	10	65

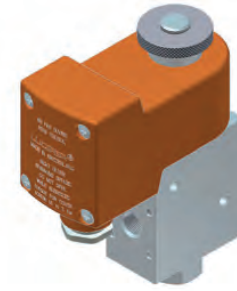
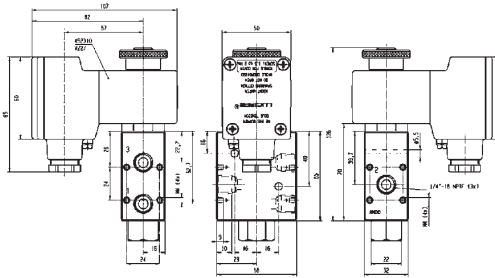

Drawing 7771

**3 & 5 WAY  
PNEUMATIC  
DISTRIBUTORS**

# 3/2

## 316L STAINLESS STEEL 3 & 5 WAY VALVES FOR ACTUATOR CONTROL (PIPE MOUNTING AND NAMUR) MANUAL RESET

### 316L STAINLESS ST. PIPE MOUNTING

### UNIVERSAL - MANUAL RESET

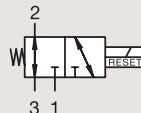

Port size	Orifice Ø 1	Flow factor Qn l/min mm	Operating Pressure Differential		Fluid Temp.		Seat Seal	Valve Ref.	Housing Ref.	Coil Ref.	ATEX Zone	Protection Mode	Power		Coil Group	Dwg. No.
			Min bar	Max (MOPD) AC DC bar	Min °C	Max °C							AC W	DC W		
1/4" NPTF	6	680	0	12 12	-40 65	VMQ	U033X7759 <sub>1</sub>	-	496895	-	-	8 8			8544	
	6	680	0	12 12	-40 65	VMQ	U033X7759 <sub>1</sub>	-	497105	1-21 Ex db IIC T4 to T6		8 8			8537	
	6	680	0	12 12	-40 65	VMQ	U033X7759 <sub>1</sub>	-	496700	1-21 Ex db mb IIC T4 to T6		6 6			8545	
	6	680	0	12 12	-40 65	VMQ	U033X7759 <sub>1</sub>	-	492310	1-21 Ex mb II T4 to T5		9 8			8546	

**Notes:**

1. Valve delivered with an individual material traceability certificate (2.2 following EN10204)

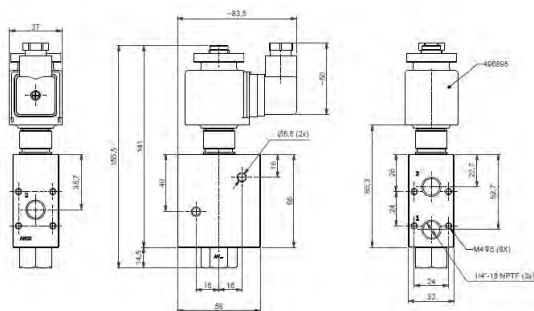

Drawing 8544

### 3 & 5 WAY PNEUMATIC DISTRIBUTORS



For this page	Port size	Orifice (mm)	Qn (l/min)	MOPD (bar)	Fluid Temp (°C)
From	1/4"	6	680	10	-40
To	1/4"	6	680	10	65

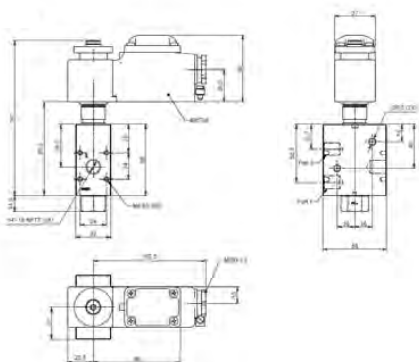

Drawing 8545

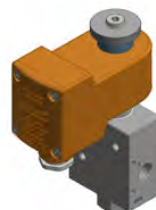
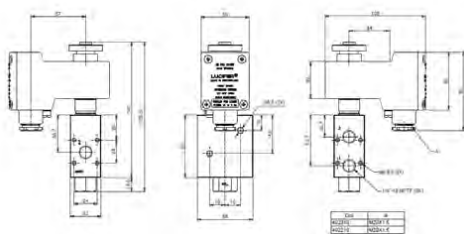

Drawing 8546

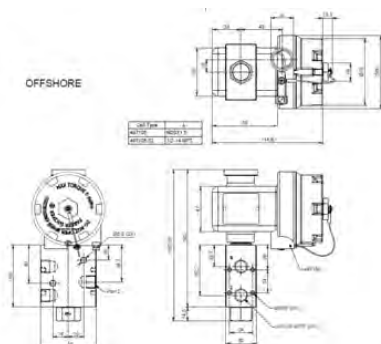

Drawing 8537



**3 & 5 WAY  
PNEUMATIC  
DISTRIBUTORS**

# 3/2

## 316L STAINLESS STEEL 3 & 5 WAY VALVES FOR ACTUATOR CONTROL (PIPE MOUNTING AND NAMUR) MANUAL RESET

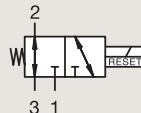
**316L STAINLESS ST.  
PIPE MOUNTING**
**UNIVERSAL**

Port size	Orifice Ø	Flow factor	Operating Pressure Differential		Fluid Temp.		Seat Seal	Valve Ref.	Housing Ref.	Coil Ref.	ATEX Zone	Protection Mode	Power		Coil Group	Dwg. No.
			Min	Max (MOPD)	Min	Max							AC W	DC W		
1/4" NPTF	6	560	0	12 12	-25	65	FKM	U033X5195	-	492310	1-21	Ex e mb II T3 to T6	6	6	10.1/10.2/12.0	3594
	6	560	0	12 12	-25	65	FKM	U033X5195	-	496700	1-21	Ex d mb IIC T4 to T6	6	6	10.1/10.2/12.0	3594

**Notes:**

1. Valve delivered with an individual material traceability certificate (2.2 following EN10204)

### 3 & 5 WAY PNEUMATIC DISTRIBUTORS



For this page	Port size	Orifice (mm)	Qn (l/min)	MOPD (bar)	Fluid Temp (°C)
From	1/4"	6	560	10	-25
To	1/4"	6	680	10	65

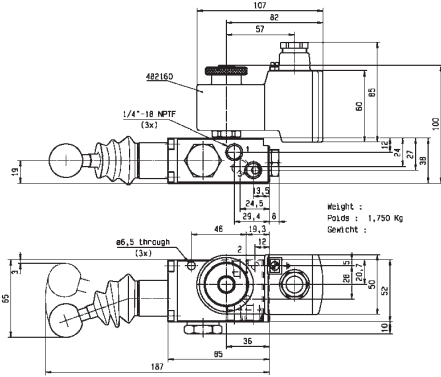

Drawing 3594

### 3 & 5 WAY PNEUMATIC DISTRIBUTORS

# 3/2

## 316L STAINLESS STEEL 3 & 5 WAY VALVES FOR ACTUATOR CONTROL (PIPE MOUNTING AND NAMUR) MANUAL RESET

### 316L STAINLESS ST. PIPE MOUNTING

#### UNIVERSAL

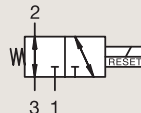

Port size	Orifice Ø 1	Flow factor Qn l/min	Operating Pressure Differential			Fluid Temp.		Seat Seal	Valve Ref.	Housing Ref.	Coil Ref.	ATEX Zone	Protection Mode	Power		Coil Group	Dwg. No.
			Min	Max (MOPD) AC bar	DC bar	Min °C	Max °C							AC W	DC W		
3/8" NPTF	6	680	0	-	10	-25	65	NBR	U033X5256 <sub>1</sub>	-	482870.01	0-20	Ex ia IIC T6	-	0.3 to 3	10.1/10.2/12.0	7671
	6	680	0	10	10	-25	65	NBR	U033X5256 <sub>1</sub>	-	492310	1-21	Ex e mb II T3 to T6	6	6	10.1/10.2/12.0	7671
	6	680	0	10	10	-25	65	NBR	U033X5256 <sub>1</sub>	-	496700	1-21	Ex d mb IIC T4 to T6	6	6	10.1/10.2/12.0	7671

#### Notes:

1. Valve delivered with an individual material traceability certificate (2.2 following EN10204)



### 3 & 5 WAY PNEUMATIC DISTRIBUTORS



For this page	Port size	Orifice (mm)	Qn (l/min)	MOPD (bar)	Fluid Temp (°C)
From	3/8"	6	680	10	-25
To	3/8"	6	680	10	65

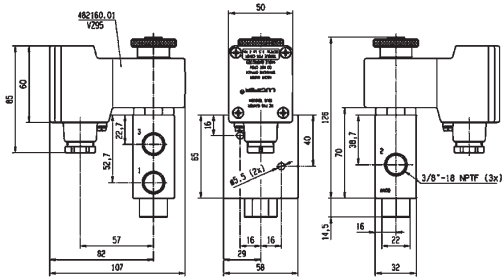

Drawing 7671





## EPP4 Series

# ELECTROPNEUMATIC PRESSURE REGULATORS



aerospace  
climate control  
electromechanical  
filtration  
fluid & gas handling  
hydraulics  
pneumatics  
process control  
sealing & shielding

<b>Basic</b>	1/4" 1/2"
<b>Comfort</b>	1/4" 1/2"
<b>Comfort</b>	1/2" HP 1" 2"
<b>Comfort ATEX</b>	1/2" 1" 2"



## EPP4 Series

# ELECTROPNEUMATIC PRESSURE REGULATORS

## EPP4 Programmable Pressure Regulator

EPP4 is an electro pneumatic pressure regulator with integrated electronic system.

A pulsed width modulated solenoid valve controls the output pressure proportionally to an analog input signal.

Very high accuracy is guaranteed thanks to a high precision closed loop signal provided by a built in pressure sensor.

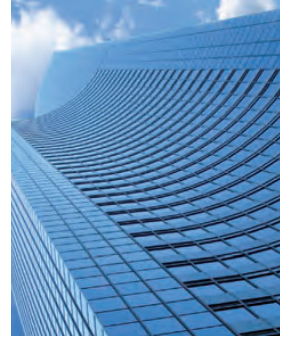

## Market

- Robotics
- Paper industry
- Machine tools
- Mobile
- Buildings
- Textile
- Instrumentation
- Semi conductor



## Description of Applications

- Welding
- Speed and brake control
- Sanding
- Cutting
- Humidification
- Tension regulation
- Painting
- Presses
- Polishing
- Adaptative suspension control



## Value Propositions for the EPP4 Range of Proportional Pressure Regulators

- All parameters fully adjustable through the PC software Calys
- Easy to use software
- Long life expectancy
- Compact and light
- Limited inventory
- Low power
- Flexible remote display positioning
- Proven expertise of Parker, a pioneer in pressure regulation technology

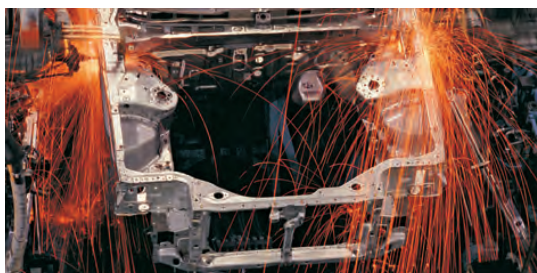

### *calys* Software for EPP Comfort

Calys is a unique software in house developed to configurate all the parameters of the EPP4 Comfort range. Calys is an option of the EPP4. To use CALYS, you need to cable reference 496449 wich permits the communication between the EPP4 and a PC.

Calys offers many capabilities:

- It enables distributors to reduce inventory by keeping a generic EPP4 in stock and adjust it to the needs of each customer application. They can switch for example from 0-10 V to 4-20 mA, or from 0-7 bar pressure range to 0-5 bar.
- Engineers designing a pneumatic system are able to monitor precisely all the important values (electrical or pneumatical) directly on their laptop.
- After sales technicians are able to receive via email all the parameters measured by the EPP4 installed on a machine wherever its location allowing remote ma intenance operation.
- PID regulation parameters can be adjusted with Calys to match required regulator response (like slow or reactive).

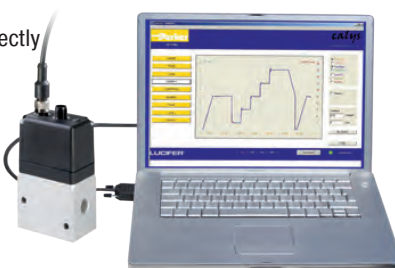
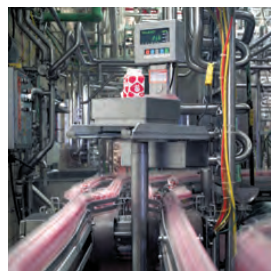

To download free Calys software click on [www.parker.com](http://www.parker.com)



EPP4 Series

# ELECTROPNEUMATIC PRESSURE REGULATORS

**TABLE OF CONTENT**



**Introduction EPP** .....page 384

**EPP4 Basic Range** .....page 386

**EPP4 Comfort Range** .....page 390

**EPP4 Comfort HP Range** .....page 394

**EPP4 Comfort Range ATEX** .....page 400

**Accessories** .....page 406

## INTRODUCTION

### Description Operation

The EPP4 Series is a family of electrically remote-controlled pneumatic pressure regulators with closed loop integrated electronic control.

It allows regulating the outlet pressure proportionally to an electrical control signal.

The EPP4 regulator comprises a traditional servo-operated pneumatic pressure regulator, where the pilot chamber is fed by one or the other of two pulse width modulated 2-way solenoid valves.

The pressure sensor measures the outlet pressure of the regulator and provides a feedback signal to the controller.

Any difference between the control signal and the feedback signal is converted to a digital signal to energise the coil of one or the other 2-way valves to correct the position of the regulator.

The control signal can be a voltage (0-10 V) or a current (4-20 mA). The inlet of the "Filling Valve" is connected directly to the main inlet P of the regulator;

when energised this valve will fill the servo-chamber for increasing the pressure at the outlet A of the regulator.

When the other "exhaust valve" is energised (reduction of pressure at the outlet A of the regulator), the pressure of the servo-chamber will be exhausted through a discharge orifice located between the cover and the body and directly fed to the atmosphere without silencer.

The exhaust of the main regulated pressure will be made through the quick exhaust R.

The use of a conventional silencer is recommended. Both solenoid valves assure the Filling or Emptying of the servo-chamber in order to increase or decrease the pressure at the outlet of the regulator.

In rest position of the valves all ports are blocked.

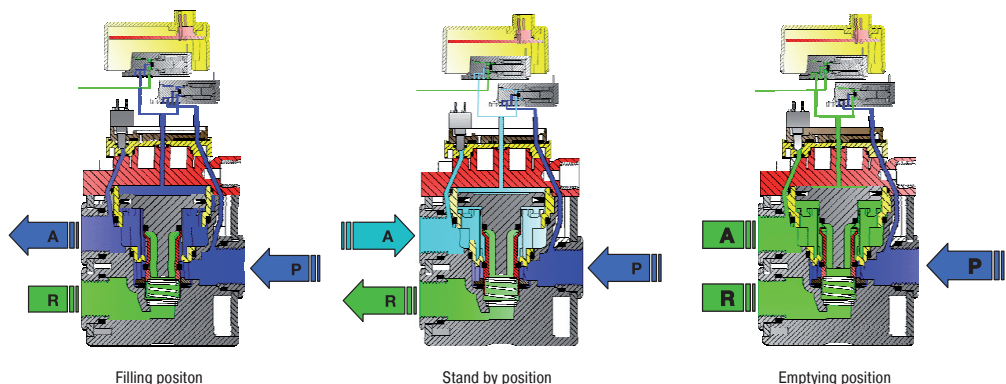

## Block Diagram

The controller receives both the control signal (set pressure) and the feedback signal from the sensor (outlet pressure).

Any difference between the two amplifier inputs results in a corresponding output which drives the appropriate 2-way pulse width modulated solenoid valve so that the pilot piston moves to correct the pressure.

The same feedback signal from the sensor is used for the output feedback in voltage and current.

The digital signal (alarm) is activated when the conditions (out of pressure or time tolerance) are met.

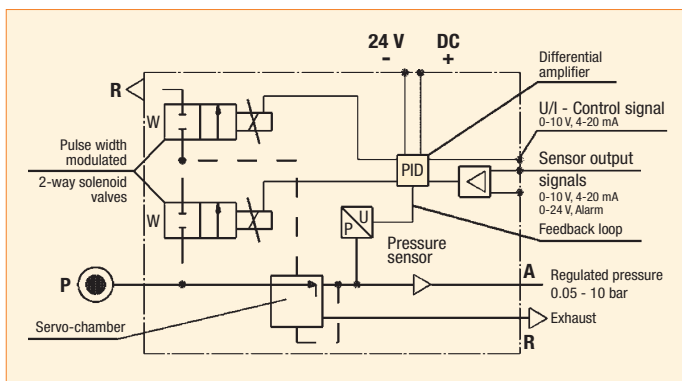

## EPP4 possible executions : Basic and Comfort

EPP4 Basic and Comfort ranges share the same reliable mechanical parts. Proportional regulation is also identical for the two different executions, giving the same characteristics for hysteresis or precision for instance.

Comfort range regulators have a second M12 connector, that can be used to connect a remote display showing the current regulated pressure, or a PC to easily set the regulation's parameters. These are the key feature options for a comfortable use.

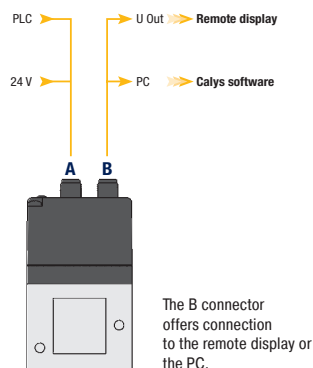

## EPP4 BASIC 1/4" & 1/2"

<b>Basic</b>	1/4" 1/2"
<b>Comfort</b>	1/4" 1/2"
<b>Comfort</b>	1/2" HP 1" 2"
<b>Comfort ATEX</b>	1/2" 1" 2"

### TECHNICAL DATA

	Basic 1/4"	Basic 1/2"
Fluids:	Lubricated or non lubricated air and neutral gases Recommended filtration: 50 µm	
Temperature range:	Ambient: 0°C to +50°C Fluid: 0°C to +50°C	
Inlet pressure range: The inlet pressure must always be at least 1 bar above the regulated pressure.	1 to 12 bar	1 to 12 bar
Outlet pressure range:	0.05 to 10 bar	
Hysteresis:	± 50 mbar (factory set up)	
Air consumption at constant control signal:	0	
Supply voltage:	24 V DC ± 15% (Max. ripple 1 V)	
Power consumption:	Max. 2.8 W with 24 V DC and constant changes of the control signal < 1.5 W without change of control signal	
Control signal:	Analog 0 - 10 V Analog 4 - 20 mA	
Max. flow: Indicative response time: With a volume of 330 cm <sup>3</sup> at the outlet of the regulator	70 m <sup>3</sup> /h	150 m <sup>3</sup> /h
Filling 2 to 4 bar:	50 msec	60 msec
Filling 2 to 8 bar:	100 msec	120 msec
Emptying 4 to 2 bar:	70 msec	90 msec
Emptying 8 to 2 bar:	130 msec	190 msec
Safety position:	In case of control signal failure or if it is less than 50mV, the regulated pressure drops automatically to 0 bar (atmospheric pressure). In case of voltage supply failure, the regulated pressure will be kept constant.	
Electrical connection:	M12 - 4 pin; 4 x 0.34 mm <sup>2</sup>	
Life expectancy:	> 50 Million changes of control signal steps	
Mounting position:	Indifferent (recommended position: upright; electronic part on top)	
Resistance to vibrations:	30 g in all directions	
Degree of protection:	IP 65	
Assembly:	Silicone free	
Electromagnetic compatibility: In accordance with:	EN 61000-6-1: 2001 EN 61000-6-2: 2001 EN 61000-6-3: 2001 EN 61000-6-4: 2001	
Installation and setting instructions:	See our "Notice 408038, 408014" and appendix supplied with the product.	

Note: Parker reserves the right to change specifications without notification.



## EPP4 BASIC 1/4" & 1/2"

### FLOW CURVES

Flow Curve Basic 1/4"

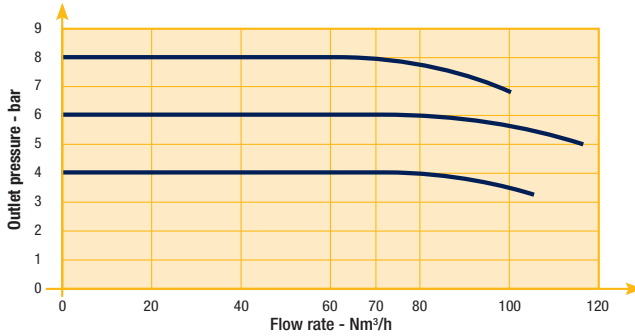

Flow Curve Basic 1/2"

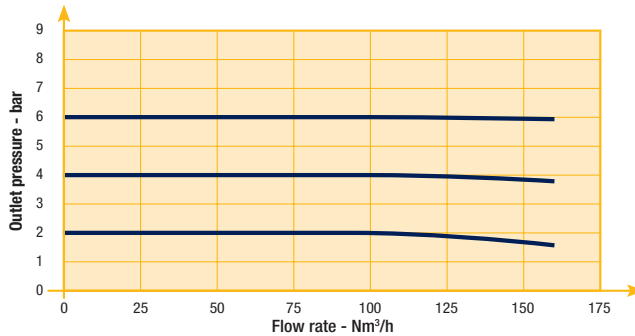

**EPP4 BASIC 1/4" & 1/2"**
**REFERENCES**

Codes	Pipe	Pressure Range (bar)	Control Signal (see options)	Drawing Number
P4BG2001A001	G 1/4"	0 4 bar	4 - 20 mA	1
P4BG2001A002	G 1/4"	0 10 bar	0 - 10 V	1
P4BG2001A003	G 1/4"	0 10 bar	4 - 20 mA	1
P4BG2001A004	G 1/4"	0 6 bar	0 - 10 V	1
P4BG2001A005	G 1/4"	0 6 bar	4 - 20 mA	1
P4BG2001A006	G 1/4"	0 5 bar	0 - 10 V	1
P4BG2001A007	G 1/4"	0 5 bar	4 - 20 mA	1
P4BG2001A008	G 1/4"	0 7 bar	0 - 10 V	1
P4BG2001A009	G 1/4"	0 7 bar	4 - 20 mA	1
P4BG2003A002 *	G 1/4"	0 10 bar	0 - 10 V	1
P4BG2003A003 *	G 1/4"	0 10 bar	4 - 20 mA	1
P4BG4001A002	G 1/2"	0 10 bar	0 - 10 V	2
P4BG4001A003	G 1/2"	0 10 bar	4 - 20 mA	2
P4BG4001A004	G 1/2"	0 6 bar	0 - 10 V	2
P4BG4001A005	G 1/2"	0 6 bar	4 - 20 mA	2
P4BG4001A006	G 1/2"	0 5 bar	0 - 10 V	2
P4BG4001A007	G 1/2"	0 5 bar	4 - 20 mA	2
P4BG4001A008	G 1/2"	0 7 bar	0 - 10 V	2
P4BG4001A009	G 1/2"	0 7 bar	4 - 20 mA	2
P4BG4004A010 ***	G 1/2"	0 4 bar	0 - 10 V	2
P4BG4051A002 **	G 1/2"	0 10 bar	4 - 20 mA	2
P4BN2001A002	NPT 1/4"	0 10 bar	0 - 10 V	2
P4BN2001A003	NPT 1/4"	0 10 bar	4 - 20 mA	2
P4BN4001A002	NPT 1/2"	0 10 bar	0 - 10 V	2
P4BN4001A003	NPT 1/2"	0 10 bar	4 - 20 mA	2

\* Integrated pilot exhaust  
 \*\* O2  
 \*\*\* External pressure supply



# EPP4 BASIC 1/4" & 1/2"

## DIMENSIONS DRAWINGS EPP4 BASIC 1/4"

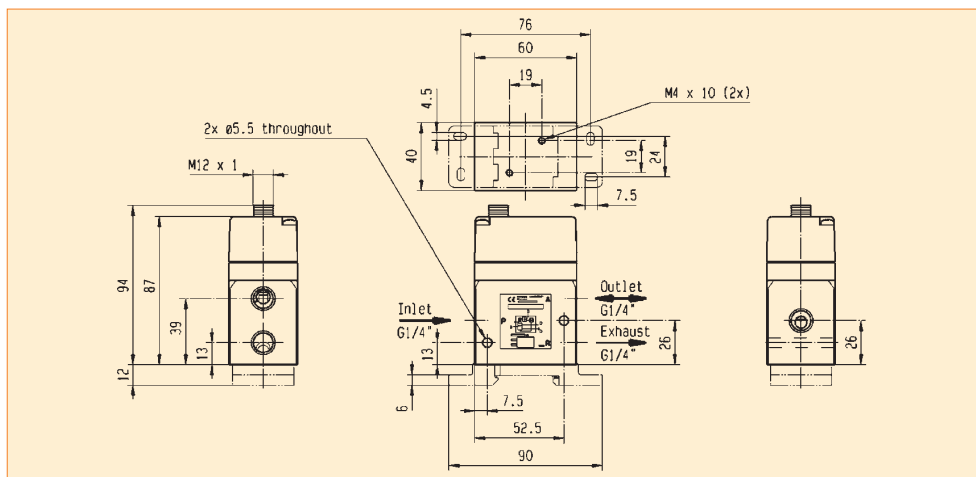

Drawing 1

## DIMENSIONS DRAWINGS EPP4 BASIC 1/2"

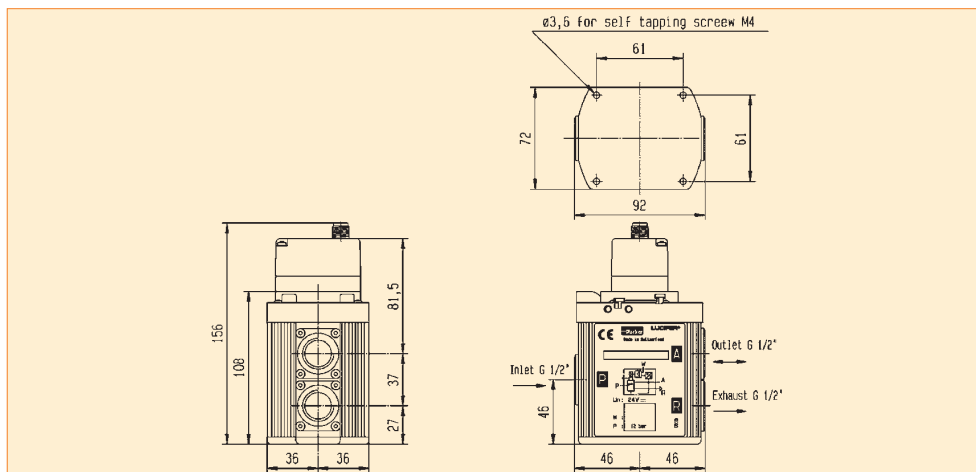

Drawing 2



## EPP4 COMFORT 1/4" & 1/2"

Basic	1/4" 1/2"
Comfort	1/4" 1/2"
Comfort	1/2" HP 1" 2"
Comfort ATEX	1/2" 1" 2"

### TECHNICAL DATA

	Comfort 1/4"	Comfort 1/2"
Fluids:	Lubricated or non lubricated air and neutral gases - Recommended filtration: 50 µm	
Temperature range:	Ambient: 0°C to +50 °C Fluid: 0°C to +50 °C	
Inlet pressure range: The inlet pressure must always be at least 1 bar above the regulated pressure.	1 to 12 bar	1 to 12 bar
Outlet pressure range:	0.05 bis 10 bar	
Hysteresis:	± 50 mbar (factory set up)	
Air consumption at constant control signal:	0	
Supply voltage:	24 V DC ± 15 % (Max. ripple 1 V)	
Power consumption:	Max. 2.8 W with 24 V DC and constant changes of the control signal < 1.5 W without change of control signal	
Control signal:	Analog 0 - 10 V Analog 4 - 20 mA	
Outlet sensor signal:	Analog 0 - 10 V Standard for 0 - 10 bar; Adjustable  Analog 4 - 20 mA Standard for 0 - 10 bar; Adjustable	Digital 0/24 V for alarm features: Adjustable pressure error (+/-) Adjustable delay ON Adjustable delay OFF Adjustable logic (+/-)
Max. flow:	70 m³/h	150 m³/h
Indicative response time:	With a volume of 330 cm³ at the outlet of the regulator	
Filling 2 to 4 bar :	50 msec	60 msec
Filling 2 to 8 bar:	100 msec	120 msec
Emptying 4 to 2 bar:	70 msec	90 msec
Emptying 8 to 2 bar:	130 msec	190 msec
Safety position:	In case of control signal failure or if it is less than 50 mV, the regulated pressure drops automatically to 0 bar (atmospheric pressure).  In case of voltage supply failure, the regulated pressure will be kept constant.	
Electrical connection:	M12 - 8 pin; male connector power supply/control signal M12 - 5 pin; male connector communication	
Life expectancy:	> 50 Million changes of control signal steps	
Mounting position:	Indifferent (recommended position: upright; electronic part on top)	
Resistance to vibrations:	30 g in all directions	
Degree of protection:	IP 65	
Assembly:	Silicone free	
Electromagnetic compatibility: In accordance with:	EN 61000-6-1: 2001 EN 61000-6-2: 2001 EN 61000-6-3: 2001 + A11 2004 edition (01/07/07) EN 61000-6-4: 2001	
Installation and setting instructions:	See our "Notice 408128, 408134" and appendix supplied with the product.	

Note: Parker reserves the right to change specifications without notification.



## EPP4 COMFORT 1/4" & 1/2"

### Flow Curves

Flow Curve 1/4"

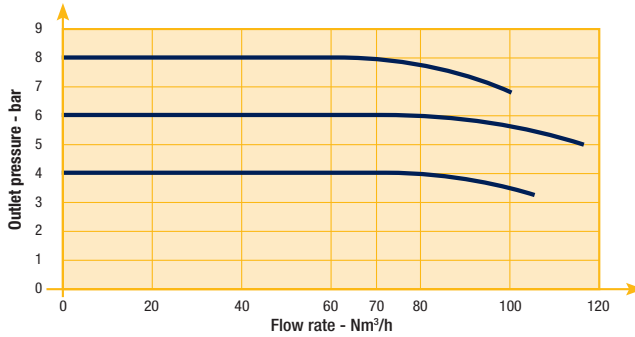

Flow Curve 1/2"

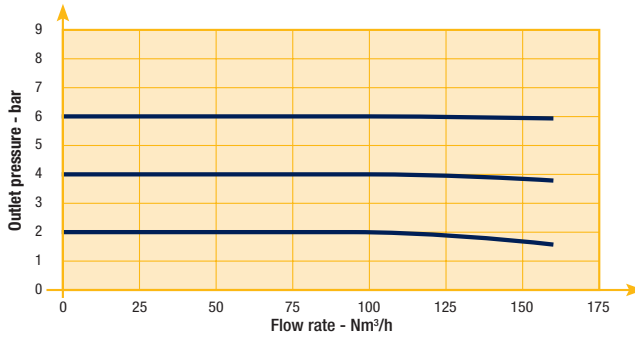

**EPP4 COMFORT 1/4" & 1/2"**
**REFERENCES**

Codes	Pipe	Pressure Range (bar)		Control Signal (see options)	Display	Drawing Number
P4CG2001C001	G 1/4	0	10	0-10 V	-	3
P4CG2001C002	G 1/4	0	10	4-20 mA	-	3
P4CG2001C005	G 1/4	0	7	0-10 V	-	3
P4CG2001C006	G 1/4	0	7	4-20 mA	-	3
P4CG2002C001	G 1/4	0	10	0-10 V	included	3
P4CG2002C002	G 1/4	0	10	4-20 mA	included	3
P4CG2003C001 *	G 1/4	0	10	0-10 V	-	3
P4CG2003C002 *	G 1/4	0	10	4-20 mA	-	3
P4CG2002C007	G 1/4	0	7	0-10 V	-	3
P4CG2002C008	G 1/4	0	7	4-20 mA	-	3
P4CN2001C001	1/4 NPT	0	10	0-10 V	-	3
P4CN2001C002	1/4 NPT	0	10	4-20 mA	-	3
P4CN2002C001	1/4 NPT	0	10	0-10 V	included	3
P4CN2002C002	1/4 NPT	0	10	4-20 mA	included	3
P4CG4001C001	G 1/2	0	10	0-10 V	-	4
P4CG4001C002	G 1/2	0	10	4-20 mA	-	4
P4CG4001C005	G 1/2	0	7	0-10 V	-	4
P4CG4001C006	G 1/2	0	7	4-20 mA	-	4
P4CG4002C001	G 1/2	0	10	0-10 V	included	4
P4CG4002C002	G 1/2	0	10	4-20 mA	included	4
P4CG4002C005	G 1/2	0	7	0-10 V	-	4
P4CG4002C006	G 1/2	0	7	4-20 mA	-	4
P4CG4051C001 **	G 1/2	0	10	0-10 V	-	4
P4CG4051C002 **	G 1/2	0	10	4-20 mA	-	4
P4CN4001C001	1/2 NPT	0	10	0-10 V	-	4
P4CN4001C002	1/2 NPT	0	10	4-20 mA	-	4
P4CN4002C001	1/2 NPT	0	10	0-10 V	included	4
P4CN4002C002	1/2 NPT	0	10	4-20 mA	included	4

\* Integrated pilot exhaust

\*\* O2



# EPP4 COMFORT 1/4" & 1/2"

## DIMENSIONS DRAWINGS EPP4 COMFORT RANGE 1/4"

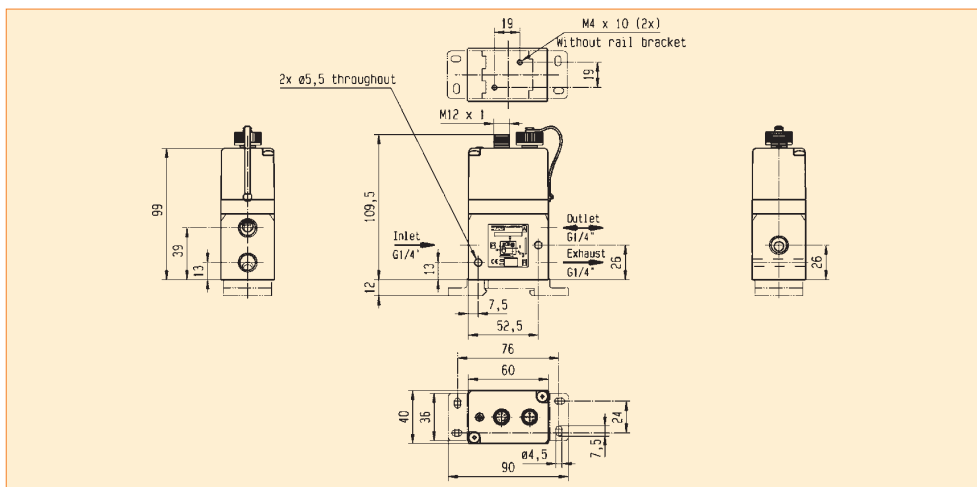

Drawing 3

## DIMENSIONS DRAWINGS EPP4 COMFORT RANGE 1/2"

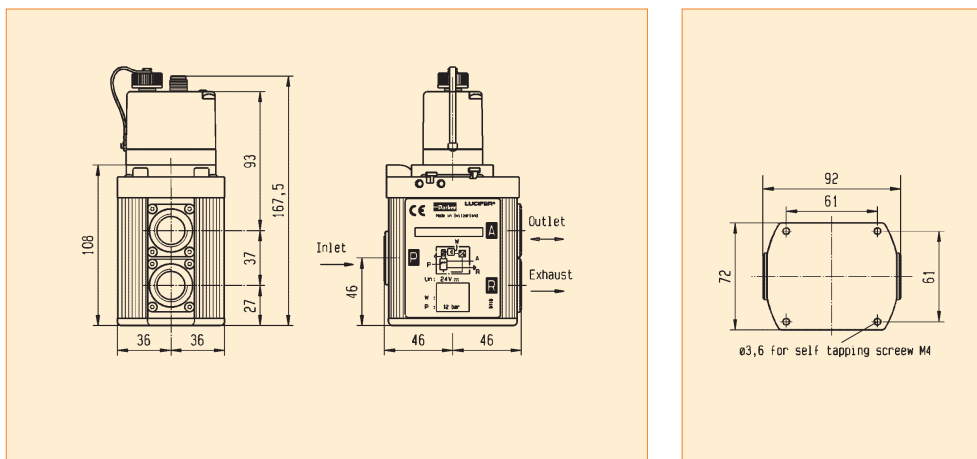

Drawing 4



## EPP4 COMFORT 1/2"HP, 1" & 2"

Basic	1/4" 1/2"
Comfort	1/4" 1/2"
<b>Comfort</b>	<b>1/2" HP</b> <b>1" 2"</b>
Comfort ATEX	1/2" 1" 2"

### TECHNICAL DATA

	Comfort 1/2" HP	Comfort 1"	Comfort 2"
Fluids:	Lubricated or non lubricated air and neutral gases - Recommended filtration: 50 µm		
Temperature range:	Ambient: 0°C to +50°C Fluid: 0°C to +50°C		
Inlet pressure range: The inlet pressure must always be at least 1 bar above the regulated pressure.	1 to 21 bar	1 to 21 bar	1 to 12 bar
Outlet pressure range:	0.05 to 20 bar	0.05 to 20 bar	0.05 to 10 bar
Hysteresis:	≤ 100 mbar if P inlet ≤ 10 bar ≤ 200 mbar if P inlet > 10 bar		
Air consumption at constant control signal:	0		
Supply voltage:	24V DC ± 15%		
Power consumption:	Max. 6 W with 24 V DC and constant changes of the control signal < 2 W without change of control signal		
Control signal:	Analog 0 - 10 V Analog 4 - 20 mA		
Outlet sensor signal:	Analog 0 - 10 V Standard for 0 - 10 bar; Adjustable	Digital 0/24 V for alarm features: Adjustable pressure error (+/-) Adjustable delay ON Adjustable delay OFF Adjustable logic (+/-)	
Max. flow:	150 m³/h	1 000 m³/h	2 700 m³/h
Indicative response time:	With a volume of 330 cm³ at the outlet of the regulator		
Filling 2 to 8 bar:	120 msec	250 msec	250 msec
Emptying 8 to 2 bar:	190 msec	400 msec	400 msec
Safety position:	In case of control signal failure or if it is less than 50 mV, the regulated pressure drops automatically to 0 bar atmospheric pressure (for pressure ranges from 0-10 bar, 100 mV for pressure range over 10 bar). In case of voltage supply failure, the regulated pressure will be kept constant.		
Electrical connection:	M12 - 8 pin; male connector power supply/control signal M12 - 5 pin; male connector communication		
Life expectancy:	> 20 Million changes of control signal steps		
Mounting position:	Indifferent (recommended position: upright; electronic part on top)		
Resistance to vibrations:	30 g in all directions		
Degree of protection:	IP 65		
Assembly:	Silicone free		
Electromagnetic compatibility: In accordance with:	EN 61000-6-1: 2001 EN 61000-6-2: 2001 EN 61000-6-3: 2001 + A11 2004 edition (01/07/07) EN 61000-6-4: 2001		
Installation and setting instructions:	See our "408 193" and appendix supplied with the product.		

Note: Parker reserves the right to change specifications without notification.

## EPP4 COMFORT 1/2"HP, 1" & 2"

### FLOW CURVES

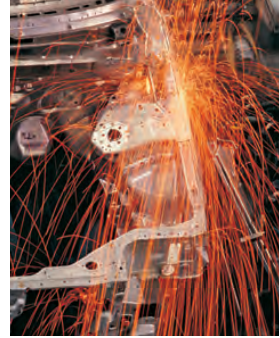

Flow Curve 1/2"HP

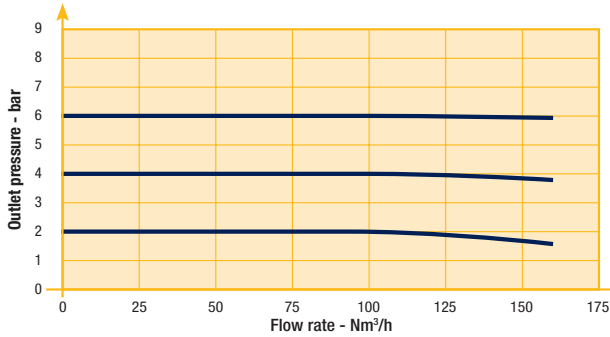

Flow Curve 1"

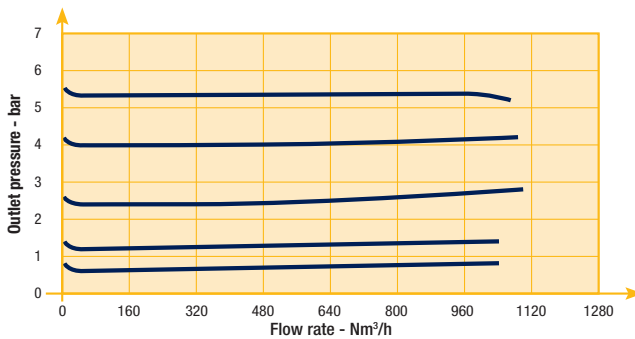

Flow Curve 2"

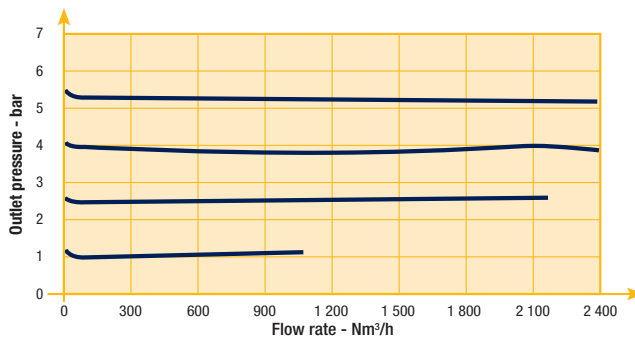

## EPP4 COMFORT 1/2"HP

### REFERENCES

Codes	Pipe	Max inlet pressure (bar)	Pressure range (bar)	Control signal (see options)	Dimensional Drawing
P4CG4101D001	G1/2	15	0 12	0-10 V	5
P4CG4201D005	G1/2	21	0 16	0-10 V	6
P4CG4201D003	G1/2	21	0 20	0-10 V	6
P4CG4201D004	G1/2	21	0 20	4-20 mA	6

Other specific settings or specialties are available, please contact us.



# EPP4 COMFORT 1/2"HP

## DIMENSIONS DRAWINGS

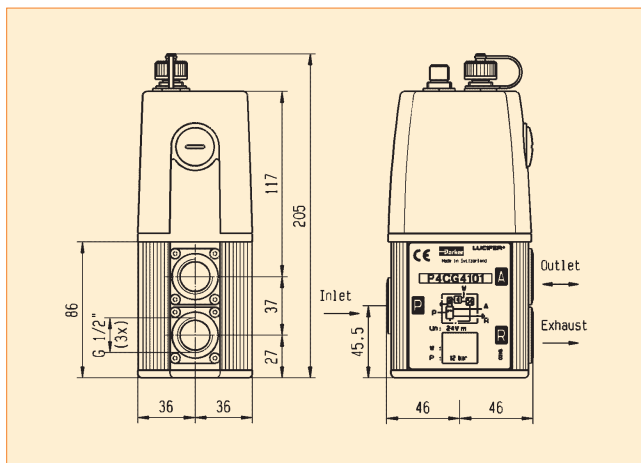

Drawing 5

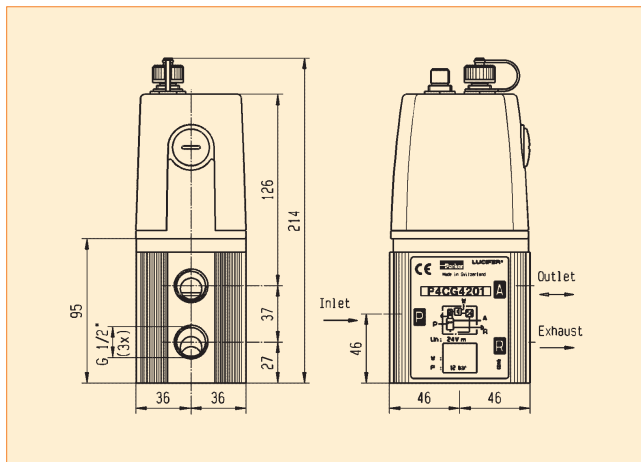
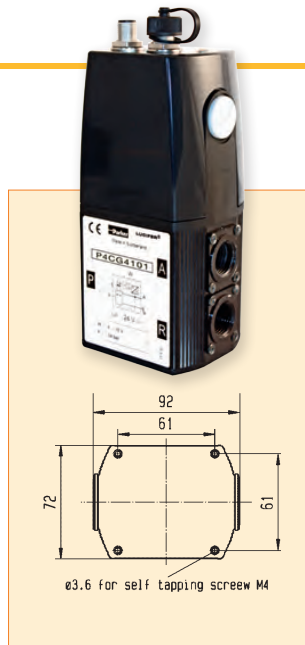

Drawing 6

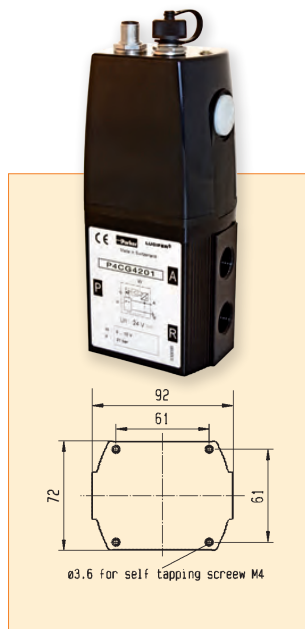

## EPP4 COMFORT 1" & 2"

### REFERENCES

Codes	Pipe	Max inlet pressure (bar)	Pressure range (bar)		Control signal (see options)	Dimensional Drawing
P4CG6101C009	G1	12	0	3.5	4-20 mA	7
P4CG6101C011	G1	12	0	5.0	0-10 V	7
P4CG6101C010	G1	12	0	6.0	4-20 mA	7
P4CG6101C001	G1	12	0	10	0-10 V	7
P4CG6101C002	G1	12	0	10	4-20 mA	7
P4CG6201D001	G1	21	0	12	0-10 V	7
P4CG6201D003	G1	21	0	20	0-10 V	7
P4CG9101C012	G2	12	0	4.0	4-20 mA	8
P4CG9101C010	G2	12	0	6.0	4-20 mA	8
P4CG9101C001	G2	12	0	10	0-10 V	8
P4CG9101C002	G2	12	0	10	4-20 mA	8

Other specific settings or specialties are available, please contact us.

## EPP4 COMFORT 1" & 2"

### DIMENSIONS DRAWINGS EPP4 COMFORT RANGE 1"

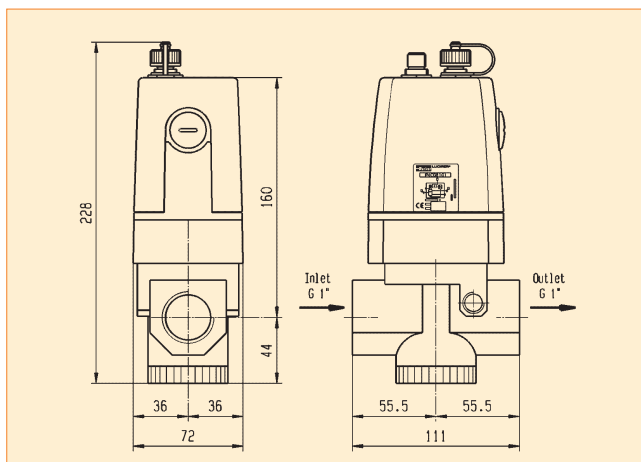

Drawing 7



### DIMENSIONS DRAWINGS EPP4 COMFORT RANGE 2"

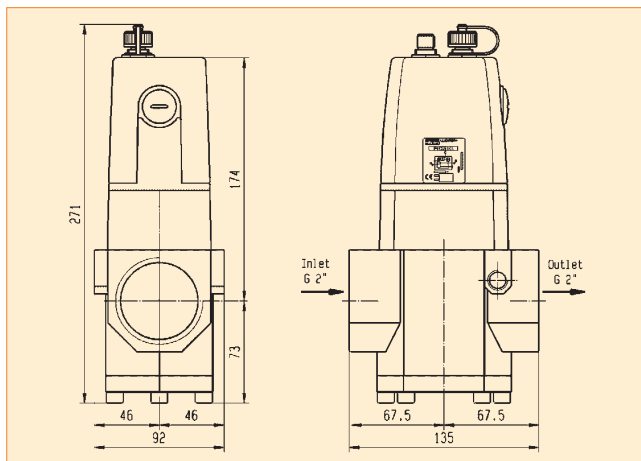

Drawing 8

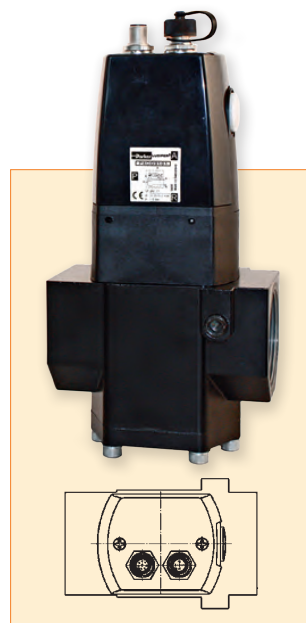

**EPP4 COMFORT 1/2", 1" & 2" ATEX**

Basic	1/4" 1/2"
Comfort	1/4" 1/2"
Comfort	1/2" HP 1" 2"
Comfort ATEX	1/2" 1" 2"

**TECHNICAL DATA**

	Comfort 1/2" ATEX	Comfort 1" ATEX	Comfort 2" ATEX
Fluids:	Lubricated or non lubricated air and neutral gases - Recommended fi filtration: 50 µm		
Temperature range:	Ambient: 0°C to +50°C Fluid: 0°C to +50°C		
Inlet pressure range: The inlet pressure must always be at least 1 bar above the regulated pressure.	Inlet pressure range: 1 to 12 bar		
Outlet pressure range:	Outlet pressure range: 0.05 to 10 bar		
Hysteresis:	≤ 100 mbar		
Air consumption at constant control signal:	0		
ATEX certification:	Ex II 3 G/D Ex nA IIC T4 Gc Ex tc IIIB T130°C Dc		
Supply voltage:	24V DC ± 15 %		
Power consumption:	Max. 6 W with 24 V DC and constant changes of the control signal < 2 W without change of control signal		
Control signal:	Analog 0 - 10 V Analog 4 - 20 mA		
Outlet sensor signal:	Analog 0 - 10 V Standard for 0 - 10 bar; Adjustable	Digital 0/24 V for alarm features: Adjustable pressure error (+/-) Adjustable delay ON Adjustable delay OFF Adjustable logic (+/-)	
	Analog 4 - 20 mA Standard for 0 - 10 bar; Adjustable		
Max. flow:	150 m³/h	1 000 m³/h	2 700 m³/h
Indicative response time:	With a volume of 330 cm³ at the outlet of the regulator		
Filling 2 to 8 bar:	120 msec	250 msec	250 msec
Emptying 8 to 2 bar:	190 msec	400 msec	400 msec
Safety position:	In case of control signal failure or if it is less than 50 mV, the regulated pressure drops automatically to 0 bar atmospheric pressure (for pressure ranges from 0-10 bar, 100 mV for pressure range over 10 bar). In case of voltage supply failure, the regulated pressure will be kept constant.		
Electrical connection:	M12 - 8 pin; male connector power supply/control signal M12 - 5 pin; male connector communication		
Life expectancy:	> 20 Million changes of control signal steps		
Mounting position:	Indifferent (recommended position: upright; electronic part on top)		
Resistance to vibrations:	30 g in all directions		
Degree of protection:	IP 54		
Assembly:	Silicone free		
Electromagnetic compatibility: In accordance with:	EN 61000-6-1: 2001 EN 61000-6-2: 2001 EN 61000-6-3: 2001 + A11 2004 edition (01/07/07) EN 61000-6-4: 2001		
Installation and setting instructions:	See our "408 283" and appendix supplied with the product.		

Note: Parker reserves the right to change specifications without notification.



# EPP4 COMFORT 1/2", 1" & 2" ATEX



## FLOW CURVES

Flow Curve 1/2"

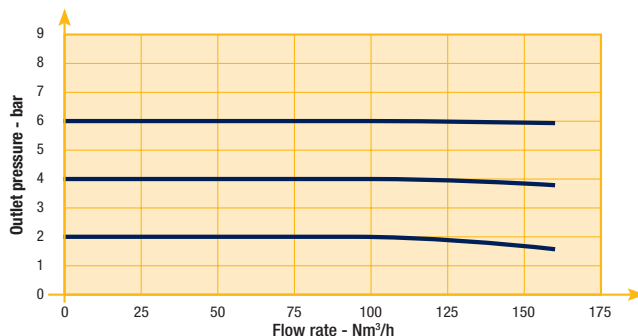

Flow Curve 1"

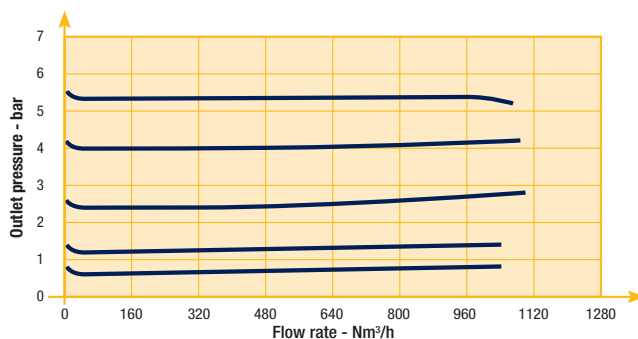

Flow Curve 2"

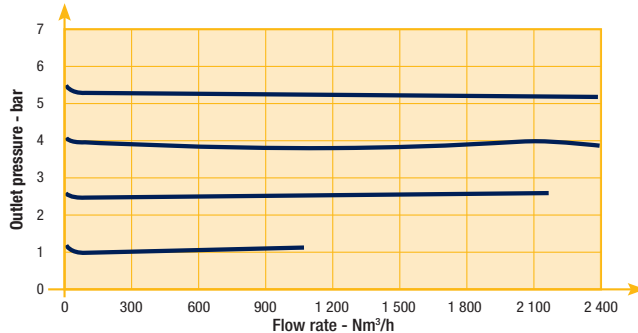

**EPP4 COMFORT 1/2" ATEX**

**REFERENCES**

Codes	Pipe	Max inlet pressure (bar)	Pressure range (bar)		Control signal (see options)	Dimensional Drawing
P4CG4461C001	G1/2	12	0	10	0-10 V	9
P4CG4461C002	G1/2	12	0	10	4-20 mA	9
P4CG4465C001 **	G1/2	12	0	10	0-10 V	9
P4CG4465C002 **	G1/2	12	0	10	4-20 mA	9

\*\* 02

Other specific settings or specialties are available, please contact us.



EPP4 COMFORT 1/2" ATEX



DIMENSIONS DRAWINGS

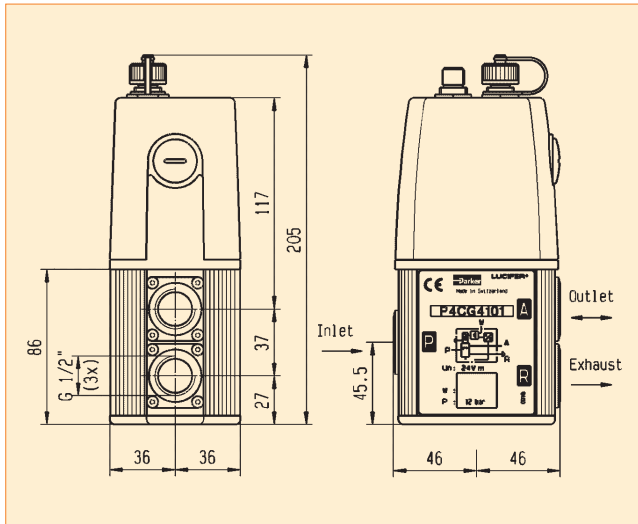

Drawing 9

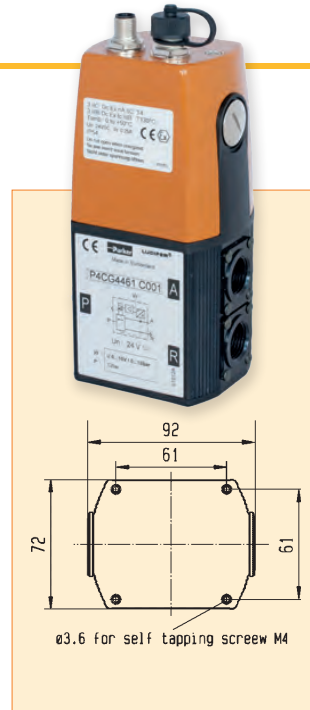

**EPP4 COMFORT 1" & 2" ATEX**

**REFERENCES**

Codes	Pipe	Max inlet pressure (bar)	Pressure range (bar)		Control signal (see options)	Dimensional Drawing
P4CG6161C001	G1	12	0	10	0-10 V	11
P4CG6161C002	G1	12	0	10	4-20 mA	11
P4CG9161C001	G2	12	0	10	0-10 V	12
P4CG9161C002	G2	12	0	10	4-20 mA	12

Other specific settings or specialties are available, please contact us.

EPP4 COMFORT 1" & 2" ATEX



**DIMENSIONS DRAWINGS EPP4 COMFORT RANGE 1"**

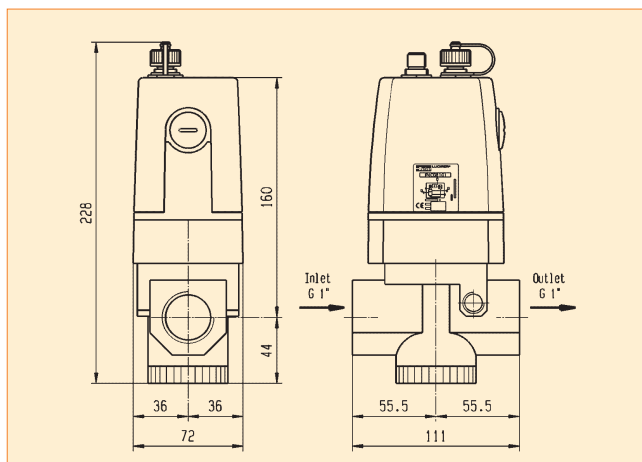

Drawing 11



**DIMENSIONS DRAWINGS EPP4 COMFORT RANGE 2"**

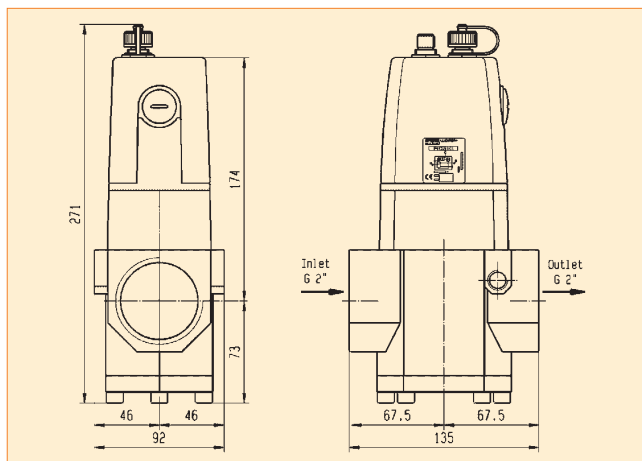

Drawing 12



## EPP4 ACCESSORIES

### MOUNTING BRACKETS FOR EPP4 1/4" BASIC / COMFORT

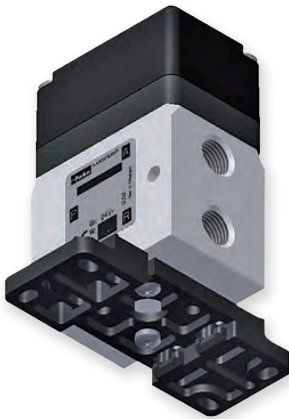

This mounting bracket is delivered as a standard with all EPP4 1/4".

## EPP4 ACCESSORIES

### MOUNTING BRACKETS FOR EPP4 1/2" BASIC / COMFORT

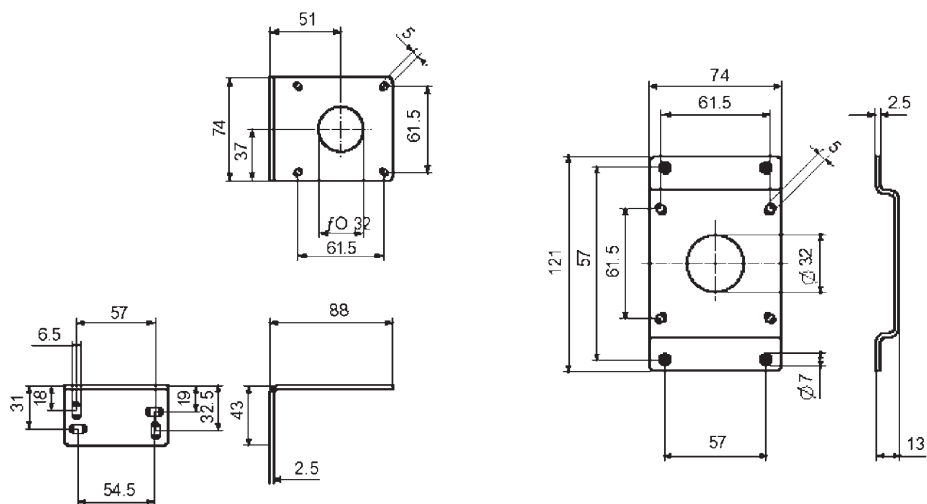

Order reference 491367



Order reference 491366



## EPP4 ACCESSORIES

### POWER SUPPLY/CONTROL SIGNAL CABLE FOR BASIC AND COMFORT VERSIONS.

Cable for Comfort EPP4

- 2 m cable with moulded straight M12-8 pole

Order Reference 496796



## EPP4 COMFORT ACCESSORIES

### calys SOFTWARE

Calys is a unique software in house developed to configure all the parameters of the EPP4 Comfort range. Calys is an option of the EPP4. A specific cable is needed for the communication between the EPP4 and a PC.

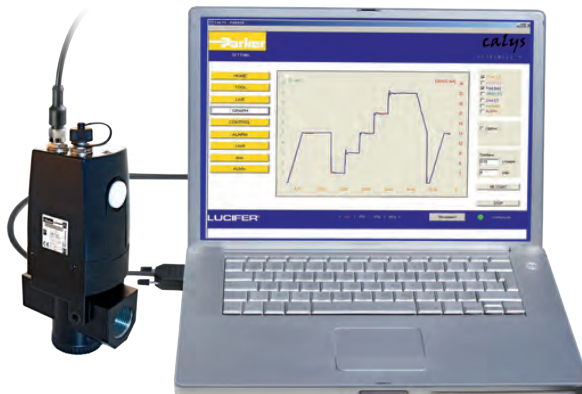

Calys offers many capabilities:

- Live monitoring (control signal, regulated pressure, supply voltage,...)
- Recording of the main parameters (control signal, regulated pressure, supply voltage,...) in an Excel file
- Free calibration for the inputs and outputs
- Adjustable alarm (positive-negative, pressure limits, delays)
- Configuration files easy to duplicate
- Complete and interactive help file

Data in 4 different pressure units

Menus in 4 languages (English, German, French and Italian)

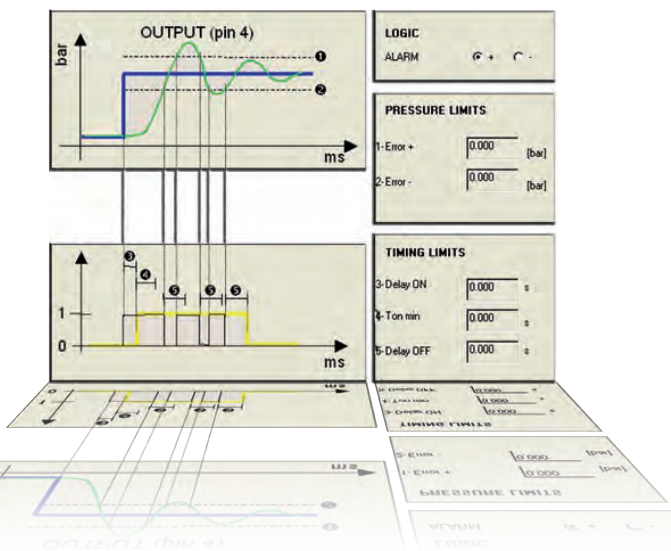

Specific communication cable PC-EPP4 with RS232 and USB connection

**Order Reference 496449**

This option is for safe area only.

EPP4 Series



# A COMPLETE RANGE OF COILS, HOUSINGS AND ELECTRICAL PARTS FOR SOLENOID VALVES



**DEFINITIONS**

**HOUSINGS OR COIL ASSEMBLY KITS,  
COILS AND ELECTRICAL PARTS**



**Housing:**

We define a **housing** as the combination of the fixing elements including the nameplate 1, the cover 2 or the subplate 6 and the envelope itself 4 or 5 which protects the coil and its electrical components. The housings may be made of metal or plastic material.

**Coil assembly kit:**

The coil assembly kit 7 or 9 is the set comprising a plate, washer and nut. Sometimes coil assembly kits consist only of a nut or a special fixing device.

**Coil:**

This consists of the winding and its plastic moulding. There are three different types of coils distinguished by their shape and dimensions: 40 mm 3, 32 mm 8 and 22 mm 10.

**Electric part:**

The electric part is the set comprising the housing, the assembly kit and the coil.

**Attention:**

Any coil or electrical part must be energised only when properly mounted on a valve.

If not, a risk of damaging the product and its surroundings (overheating, explosion, fire, etc.) can take place.



## TABLE OF CONTENT

### INTRODUCTION

Index for Explosion Proof Electrical Parts .....	414
List of Coil Groups .....	415

### COILS

Coils for DIN plug connection .....	418
Coils with flying leads .....	432
Coils with screw terminal .....	424
Coils with ISO-DIN connector .....	441

### EXPLOSION PROOF ELECTRICAL PARTS

Level of protection "nAc nCc" .....	445
Level of protection "db" .....	452
Level of protection "mb" .....	453
Level of protection "db mb" .....	457
Level of protection "eb" .....	462
Level of protection "eb mb" .....	463
Level of protection "ia" .....	466

<b>HOUSINGS</b> .....	474
-----------------------	-----

<b>COIL ACCESSORIES</b> .....	478
-------------------------------	-----

<b>EXPLOSIVE ENVIRONMENTS</b> .....	480
-------------------------------------	-----

### COIL APPENDICES

Guidance chart for IS-Barriers .....	490
--------------------------------------	-----



## INDEX FOR EXPLOSION PROOF ELECTRICAL PARTS

Coil Reference	Coil Group	Designation	Power DC Pn (W)	Power AC Pn (W)	Ambient Temperature	UL	Degree of Protection	ATEX or NEMA 4X Protection (Gas)	Page
496637	1.2	Explosion proof electrical part "nAc nCc", 22 mm, double frequency	3.0	3.0	-40°C to +50°C	-	IP65	II 3 D Ex tc IIC T 95°C	445
495880	2.0/2.2	Explosion proof electrical part "nAc nCc", 32 mm	14.0	14.0	-40°C to +50°C	-	IP65	II 3 G Ex nAc nCc IIC T3	449
496155	2.0/2.2	Explosion proof increased safety electrical part "nAc nCc", 50 mm	14.0	14.0	-40°C to +65°C	-	IP67	II 3 G Ex nAc nCc IIC T3	451
495915	4.0	Explosion proof increased safety electrical part "nAc nCc", 50 mm	13.0	11.0	-40°C to +65°C	-	IP67	II 3 G Ex nAc nCc IIC T3	450
495870	2.0/2.1	Explosion proof electrical part "nAc nCc", 32 mm	9.0	8.0	-40°C to +50°C	-	IP65	II 3 G Ex nAc nCc IIC T3/T4	446
495875	3.0	Explosion proof electrical part "nAc nCc", 32 mm	7.0	6.0	-40°C to +50°C	-	IP65	II 3 G Ex nAc nCc IIC T3/T4	448
496110	2.0/2.1	Explosion proof electrical part "nAc nCc", 32 mm	-	9.0	-40°C to +50°C	-	IP65	II 3 G Ex nAc nCc IIC T3/T4	446
495865	1.1	Explosion proof electrical part "nAc nCc", low power, 22 mm	2.5	2.0	-40°C to +50°C	-	IP65	II 3 G Ex nAc nCc IIC T5	444
496125	6.0	Explosion proof electrical part "nAc nCc", low power, 32 mm	1.6	-	-40°C to +50°C	-	IP65	II 3 G Ex nAc nCc IIC T5/T6	447
482605	1.1	Explosion proof encapsulated electrical part "mb", 32 mm	5.0	4.0	-40°C to +65°C	-	IP65	II 2 G Ex mb IIC T4/T5	453
482606	1.1	Explosion proof encapsulated electrical part "mb", low power, 32 mm	2.5	2.0	-40°C to +65°C	-	IP65	II 2 G Ex mb IIC T4/T5	453
492070	2.0/2.1	Explosion proof encapsulated electrical part "mb", with water proof metal housing, 50 mm	8.0	9.0	-40°C to +65°C	-	IP67	II 2 G Ex mb IIC T4/T5	454
HZ10	2.0/2.1	Explosion proof encapsulated electrical part "mb", double frequency	8.0	8.0	-40°C to +85°C	-	IP65	II 2 G - Ex mb IIC T3/T4/T5	455
HZ11	2.0/2.2	Explosion proof encapsulated electrical part "mb", double frequency	14.0	14	-40°C to +85°C	-	IP65	II 2 G - Ex mb IIC T3/T4/T5	456
497105	10.3	Flame proof electrical part "db", 50 mm	8.0	8.0	-50°C to +80°C	-	IP66	II 2 G Ex db IIC T4/T5/T6	452
493640	2.0/2.1	Flame proof encapsulated electrical part "db mb", double frequency	8.0	8.0	-40°C to +75°C	-	IP65	II 2 G Ex db mb IIC T4/T5	461
495905	2.0/2.1	Flame proof encapsulated electrical part "db mb", 37 mm	8.0	8.0	-40°C to +65°C	-	IP67	II 2 G Ex db mb IIC T4	458
496560	10.1	Flame proof encapsulated electrical part "db mb", 37 mm	8.0	8.0	-40°C to +80°C	-	IP67	II 2 G Ex db mb IIC T4	459
496800	10.1	Flame proof encapsulated electrical part "db mb", 37 mm	8.0	8.0	-40°C to +65°C	-	IP67	II 2 G Ex db mb IIC T4	460
495900	6.0	Flame proof encapsulated electrical part "db mb", low power, 37 mm	2.0	2.5	-40°C to +65°C	-	IP67	II 2 G Ex db mb IIC T4/T5/T6	457
496555	10.2	Flame proof encapsulated electrical part "db mb", 37 mm	6.0	6.0	-40°C to +80°C	-	IP67	II 2 G Ex db mb IIC T4/T5/T6	459
496700	10.2	Flame proof encapsulated electrical part "db mb", 37 mm	6.0	6.0	-40°C to +65°C	-	IP67	II 2 G Ex db mb IIC T4/T5/T6	460
494040	2.0/2.1	Explosion proof increased safety electrical part "eb", 50 mm	8.0	8.0	-40°C to +90°C	-	IP67	II 2 G Ex eb IIC T3/T4	462
483371	2.0/2.1	Explosion proof increased safety electrical part "eb", 50 mm	8.0	8.0	-40°C to +65°C	-	IP67	II 2 G Ex eb IIC T4	462
492190	2.0/2.1	Explosion proof increased safety and encapsulated elect. part "eb", 50 mm	9.0	11.0	-40°C to +75°C	-	IP66	II 2 G Ex eb mb IIC T3/T4	465
492310	10.1	Explosion proof increased safety and encapsulated electrical part "eb", 50 mm	6.0	6.0	-40°C to +75°C	-	IP66	II 2 G Ex eb mb IIC T4/T5	463
492210	9.0	Explosion proof increased safety and encapsulated electrical part "eb", "Booster", 50 mm	1.0 to 1.8	-	-40°C to +75°C	-	IP66	II 2 G Ex eb mb IIC T5/T6	464
495910	8.0	Explosion proof intrinsically safe electrical part "ia", "booster", 37 mm	0.3 to 1.2	-	-40°C to +80°C	-	IP67	II 1 G Ex ia IIC T4/T5/T6	467
496565	9.0	Explosion proof intrinsically safe electrical part "ia", "Booster", 37 mm	0.77 to 2.58	-	-40°C to +80°C	-	IP67	II 1 G Ex ia IIC T4/T5/T6	468
483580.01	7.0	Explosion proof intrinsically safe electrical part "ia", 32 mm	3.0	-	-40°C to +55°C	-	IP65	II 1 G Ex ia IIC T6	466
488650.01	7.0	Explosion proof intrinsically safe electrical part "ia", 50 mm	0.3 to 3.0	-	-40°C to +65°C	-	IP66	II 1 G Ex ia IIC T6	470
492965.01	9.0	Explosion proof intrinsically safe electrical part "ia", "Booster", 50 mm	0.3 to 2.3	-	-40°C to +65°C	-	IP66	II 1 G Ex ia IIC T6	469
482870.01	12.0	Explosion proof intrinsically safe electrical part "ia", 50 mm	3.0	-	-40°C to +65°C	-	IP66	II 1 G Ex ia IIC T6	471
490885	7.0	Explosion proof intrinsically safe electrical part, "NEMA", 50 mm	3.0	-	-40°C to +60°C	-	NEMA 4 - 4X	Cl. I, Div1, Gr. A, B, C, D	470

## LIST OF COIL GROUPS

Parker coils and electrical parts are classified by groups determining their compatibility with Parker solenoid valves.

Group	For application with
1.1	Standard valves or on 2000 Series with standard pilot
1.2	Standard valves or on 2000 Series for high flow
1.3	Standard valves or on 2000 Series of W coil
2.0	Standard valves or on 7000 Series with standard pilot
2.1	Standard valves or on 7000 Series, for coils 8 - 9 W
2.2	Standard valves or on 7000 Series, for coils 14 W
3.0	Standard valves or on 7000 Series with reduced power
4.0	Standard valves or on 7000 Series, for bistable (Impulse) coils or electrical parts
6.0	Special valves "97" or on 7000 Series, for Intrinsically safe coils or electrical parts
7.0	Special valves "90", for coils and intrinsically safe electrical parts
8.0	Special valves "97" or on 7000 Series, for Intrinsically safe coils or electrical parts with booster
9.0	Special valves "xx" or on 9000 Series, for Intrinsically safe coils or electrical parts with booster
10.1	Standard valves or on 9000 Series with standard pilot
10.2	Standard valves or on 9000 Series "db mb"
10.3	Special valves or on 8000 Series "d"
12.0	Standard valves or on 9000 Series with manual reset
13.0	Special valves or on 7000 Series for Transportation
14.1	Special valves or on 7000 Series for Oil Burners
14.2	Special valves or on 7000 Series for Oil Burners
14.3	Special valves or on 7000 Series for Oil Burners

**COILS**



## TABLE OF CONTENT

### INTRODUCTION

Index for Explosion Proof Electrical Parts .....	414
List of Coil Groups .....	415

### COILS

Coils for DIN plug connection .....	418
Coils with flying leads .....	432
Coils with screw terminal .....	434
Coils with ISO-DIN connector .....	441

### EXPLOSION PROOF ELECTRICAL PARTS

Level of protection "nAc nCc" .....	445
Level of protection "db" .....	452
Level of protection "mb" .....	453
Level of protection "db mb" .....	457
Level of protection "eb" .....	462
Level of protection "eb mb" .....	463
Level of protection "ia" .....	466

<b>HOUSINGS</b> .....	474
-----------------------	-----

<b>COIL ACCESSORIES</b> .....	478
-------------------------------	-----

<b>EXPLOSIVE ENVIRONMENTS</b> .....	480
-------------------------------------	-----

### COIL APPENDICES

Guidance chart for IS-Barriers .....	490
--------------------------------------	-----



# COILS

COIL GROUP

## 2.0/2.1 COILS FOR DIN PLUG CONNECTION



### COILS 32 mm

These coils can be mounted with every Parker solenoid valves corresponding to the specified Coil Group.

See column "Coil Group" within valve pages.

This is an encapsulated assembly comprising a coil, integral magnetic iron path and snap-on plug connection.

The synthetic material encapsulation provides an effective compact housing, offering full protection against dust, oil, water, etc.

Ease of mounting in confined space - offers shock and corrosion protection - simplifies conversion of existing equipment to other requirements, etc.

Coils conform to the IEC/CENELEC safety standards and complies with European low-voltage directive.



Specification		Standard			Double frequency		
Ref. (without DIN plug)		481865			483510		
Ref. (with DIN plug)							
Coil Group		2.0 / 2.1					
Degree of protection		IP65 according to IEC / EN 60529 standards (with DIN plug).					
Class of insulation		F 155°C					
Electrical connection		The coil is connected with a 2 P + E plug according to EN 175301-803 type A					
Ambient temperature		-40°C to +50°C					
		The application is limited also by the temperature range of the valve.					
Elect. Power	DC	Pn (hot)	9 W				
		P (cold) 20°C	12 W				
	AC	Pn (holding)	8 W				9 W
		Attraction cold	26 VA (9 W)				32 VA (10 W)
Weight		130 g (without plug)					
Voltages "Un"		VAC/Hz	Code	VDC	Code	VAC/Hz	Code
-10% to +10% of the Un		24/50	A2	24	C2	24/50, 24/60	PO
		48/50	A4	48	C4	48/50, 48/60	S4
		110/50	A5	110	C5	110-115/50, 120/60	S5
		220-230/50	3D			220-240/50, 240/60	S6

To Order a Coil choose Coil Ref + Voltage Code, example: 481865 for 24 VDC = 481865C2

More voltage possibilities can be found in the table of voltage codes at the end of the coil section.

These coils must be used with suitable housings, see example below:

Please use the coil assembly kit Ref. 2995.

It is composed of a nameplate giving details of the valve type, a round washer and a nut to ensure the fixing between 32 mm coil and the valve.

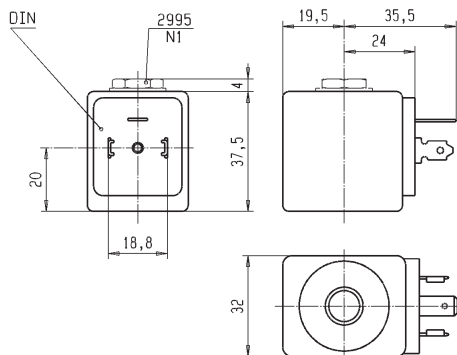

**COIL GROUP**  
**2.0/2.1**  
**2.2**

**COILS FOR**  
**DIN PLUG CONNECTION**



## HIGH TEMPERATURE COILS 32 mm

These coils can be mounted with every Parker solenoid valves corresponding to the specified Coil Group.

See column "Coil Group" within valve pages.

This is an encapsulated assembly comprising a coil, integral magnetic iron path and snap-on plug connection.

The synthetic material encapsulation provides an effective compact housing, offering full protection against dust, oil, water, etc.

Ease of mounting in confined space - offers shock and corrosion protection - simplifies conversion of existing equipment to other requirements, etc.

Coils conform to the IEC/CENELEC safety standards and complies with European low-voltage directive.



Specification		High temperature			High temp. + high power				
Ref. (without DIN plug) Ref. (with DIN plug)		492453			492425				
Coil Group		2.0 / 2.1			2.0 / 2.2				
Degree of protection		IP65 according to IEC / EN 60529 standards (with DIN plug).							
Class of insulation		H 180°C							
Electrical connection		The coil is connected with a 2 P + E plug according to EN 175301-803 type A							
Ambient temperature		-40°C to +50°C The application is limited also by the temperature range of the valve.							
Elect. Power	DC	Pn (hot)	9 W			14 W			
		P (cold) 20°C	12 W			21 W			
	AC	Pn (holding)	8 W			14 W			
		Attraction cold	26 VA (9 W)			55 VA (18 W)			
	Weight		130 g (without plug)						
Voltages "Un"		VAC/Hz	Code	VDC	Code	VAC/Hz	Code	VDC	Code
-10% to +10% of the Un		24/50	A2	24	C2	24/50	A2	24	C2
		110/50	A5			110/50	A5		
		220/50-230/50	3D	110	C5	230/50	F4		

To Order a Coil choose Coil Ref + Voltage Code, example: 492453 for 24 VDC = 492453C2

More voltage possibilities can be found in the table of voltage codes at the end of the coil section.

These coils must be used with suitable housings, see example below:

Please use the coil assembly kit Ref. 2995.

It is composed of a nameplate giving details of the valve type, a round washer and a nut to ensure the fixing between 32 mm coil and the valve.

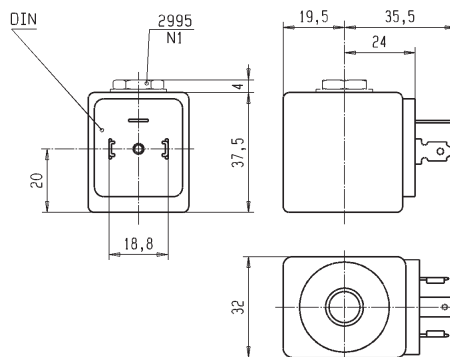

# COILS

## COIL GROUP

# 3.0

## COILS FOR DIN PLUG CONNECTION



### REDUCED POWER COIL 32 mm

These coils can be mounted with every Parker solenoid valves corresponding to the specified Coil Group.

See column "Coil Group" within valve pages.

This is an encapsulated assembly comprising a coil, integral magnetic iron path and snap-on plug connection.

The synthetic material encapsulation provides an effective compact housing, offering full protection against dust, oil, water, etc.

Ease of mounting in confined space - offers shock and corrosion protection - simplifies conversion of existing equipment to other requirements, etc.

Coils conform to the IEC/CENELEC safety standards and complies with European low-voltage directive.



Specification		Reduced power			
Ref. (without DIN plug) Ref. (with DIN plug)		482730			
Coil Group		3.0			
Degree of protection		IP65 according to IEC / EN 60529 standards (with DIN plug).			
Class of insulation		F 155°C			
Electrical connection		The coil is connected with a 2 P + E plug according to EN 175301-803 type A			
Ambient temperature		-40°C to +50°C The application is limited also by the temperature range of the valve.			
Elect. Power	DC	Pn (hot)	7 W		
		P (cold) 20°C	9 W		
	AC	Pn (holding)	6 W		
		Attraction cold	20 VA (7 W)		
Weight		130 g (without plug)			
Voltages "Un"		VAC/Hz	Code	VDC	Code
-10% to +10% of the Un		220-230/50	3D	24	C2

To Order a Coil choose Coil Ref + Voltage Code, example: 482730 for 24 VDC = 482730C2

More voltage possibilities can be found in the table of voltage codes at the end of the coil section.

These coils must be used with suitable housings, see example below:

Please use the coil assembly kit Ref. 2995.

It is composed of a nameplate giving details of the valve type, a round washer and a nut to ensure the fixing between 32 mm coil and the valve.

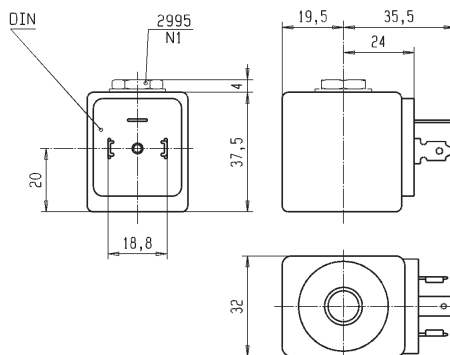

**COIL GROUP**

# 6.0

## COILS FOR DIN PLUG CONNECTION



### LOW POWER COIL 32 mm

These coils can be mounted with every Parker solenoid valves corresponding to the specified Coil Group.

See column "Coil Group" within valve pages.

This is an encapsulated assembly comprising a coil, integral magnetic iron path and snap-on plug connection.

The synthetic material encapsulation provides an effective compact housing, offering full protection against dust, oil, water, etc.

Ease of mounting in confined space - offers shock and corrosion protection - simplifies conversion of existing equipment to other requirements, etc.

Coils conform to the IEC/CENELEC safety standards and complies with European low-voltage directive.



Specification		Miniwatt	
Reference (without DIN plug) Reference (with DIN plug)		482740	
Coil Group		6.0	
Degree of protection		IP65 according to IEC / EN 60529 standards (with DIN plug).	
Class of insulation		F 155°C	
Electrical connection		The coil is connected with a 2 P + E plug according to EN 175301-803 type A	
Ambient temperature		-40°C to +50°C The application is limited also by the temperature range of the valve.	
Elect. Power	DC	Pn (hot)	1.6 W
		P (cold) 20°C	2.1 W
	AC	Pn (holding)	-
		Attraction cold	-
Weight		130 g (without plug)	
Voltages "Un" -10% to +10% of the Un		VDC 24	Code C2

To Order a Coil choose Coil Ref + Voltage Code, example: 482740 for 24 VDC = 482740C2

More voltage possibilities can be found in the table of voltage codes at the end of the coil section.

These coils must be used with suitable housings, see example below:

Please use the coil assembly kit Ref. 2995.

It is composed of a nameplate giving details of the valve type, a round washer and a nut to ensure the fixing between 32 mm coil and the valve.

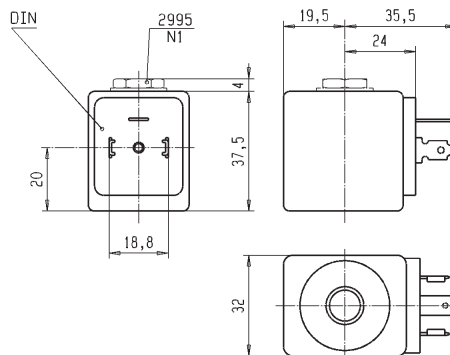

## COILS

COIL GROUP

# 2.0/2.1

### COILS FOR DIN PLUG CONNECTION



## UL COIL 32 mm

This coil can be mounted with every Parker solenoid valves corresponding to the specified Coil Group.

See column "Coil Group" within valve pages.

This is an encapsulated assembly comprising a coil, integral magnetic iron path and snap-on plug connection.

The synthetic material encapsulation provides an effective compact housing, offering full protection against dust, oil, water, etc.

Ease of mounting in confined space - offers shock and corrosion protection - simplifies conversion of existing equipment to other requirements, etc.

Coils conform to the IEC/CENELEC safety standards and complies with European low-voltage directive.

DIN plug connector to be ordered separately (see coil accessories section)



Specification		UL-recognized coil - UL File E200N - designation AMIF			
Reference (without DIN plug)		491514			
Coil Group		2.0 / 2.1			
Degree of protection		IP65 according to IEC / EN 60529 standards (with DIN plug).			
Class of insulation		F 155°C			
Electrical connection		The coil is connected with a 2 P + E plug according to EN 175301-803 type A			
Ambient temperature		-40°C to 50°C The application is limited also by the temperature range of the valve.			
Elect. Power	DC	Pn (hot)	-	12 W	
		P (cold) 20°C	-	16 W	
	AC	Pn (holding)	11 W	-	
		Attraction cold	40 VA (13 W)	-	
Weight		130 g (without plug)			
Voltages "Un"		VAC/Hz	Code	VDC	Code
- 15% to +10% of the Un		110/50-120/60 220/50-240/60	P3 Q3	24	C2

To Order a Coil choose Coil Ref + Voltage Code, example: 491514 for 24 VDC = 491514C2

More voltage possibilities can be found in the table of voltage codes at the end of the coil section.

These coils must be used with suitable housings, see example below:

Please use the coil assembly kit Ref. 2995 with non UL valve and Ref. 2995.03 with UL valve.

It is composed of a nameplate giving details of the valve type, a round washer and a nut to ensure the fixing between 32 mm coil and the valve.

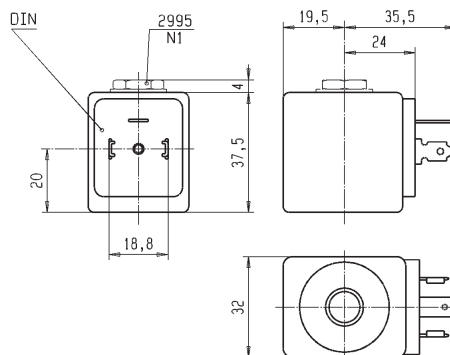

**COIL GROUP**

# 14.2

## COILS FOR DIN PLUG CONNECTION



### UL COIL 32 mm

These coils can be mounted with every Parker solenoid valves corresponding to the specified Coil Group.

See column "Coil Group" within valve pages.

This is an encapsulated assembly comprising a coil, integral magnetic iron path and snap-on plug connection.

The synthetic material encapsulation provides an effective compact housing, offering full protection against dust, oil, water, etc.

Ease of mounting in confined space - offers shock and corrosion protection - simplifies conversion of existing equipment to other requirements, etc.

Coils conform to the IEC/CENELEC safety standards and complies with European low-voltage directive.



Specification		Coil for oil burner - UL recognized	
Reference (without DIN plug)		483764	
Coil group		14.2	
Degree of protection		IP65 according to IEC / EN 60529 standards (with DIN plug).	
Class of insulation		F 155°C	
Electrical connection		With DIN 43650 A Plug	
Ambient temperature		-40°C to 50°C The application is limited also by the temperature range of the valve.	
Elect. Power	DC	Pn (hot)	-
		P (cold) 20°C	-
	AC	Pn (holding)	9 W
		Attraction cold	-
Weight		138 g	
Voltages "Un"		VAC/Hz	Code
- 15% to +10% of the Un		240/50-60	Q1
		110/50-115/60	Q9
		230/50-240/60	T1

To Order a Coil choose Coil Ref + Voltage Code, example: 483764 for 240/50-60 = 483764Q1

More voltage possibilities can be found in the table of voltage codes at the end of the coil section.

These coils must be used with suitable housings, see example below:

Please use the coil assembly kit Ref. 2995.

It is composed of a nameplate giving details of the valve type, a round washer and a nut to ensure the fixing between 32 mm coil and the valve.

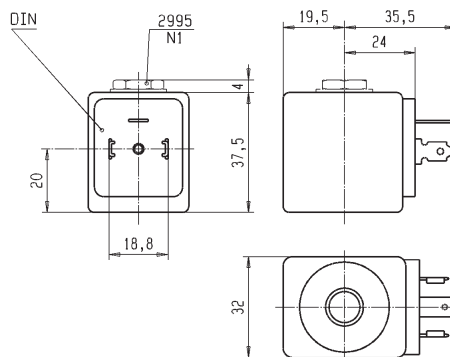

## COILS

### COIL GROUP

# 2.2

## COILS FOR DIN PLUG CONNECTION



### COIL 32 mm FOR JET VALVES

This coil can be mounted with every Parker solenoid valves corresponding to the specified Coil Group.

See column "Coil Group" within valve pages.

This is an encapsulated assembly comprising a coil, integral magnetic iron path and snap-on plug connection.

The synthetic material encapsulation provides an effective compact housing, offering full protection against dust, oil, water, etc.

Ease of mounting in confined space - offers shock and corrosion protection - simplifies conversion of existing equipment to other requirements, etc.

Coils conform to the IEC/CENELEC safety standards and complies with European low-voltage directive.

DIN plug connector to be ordered separately (see coil accessories section)



Specification		32 mm coil 14 W	
Reference		483816	
Coil Group		2.2	
Degree of protection		IP65 according to IEC / EN 60529 standards (with DIN plug).	
Class of insulation		F 155°C	
Electrical connection		The coil is connected with a 2 P + E plug according to EN 175301-803 type A	
Ambient temperature		-40°C to +50°C The application is limited also by the temperature range of the valve.	
Elect. Power	DC	Pn (hot)	14 W
		P (cold) 20°C	-
	AC	Pn (holding)	14 W
		Attraction cold	-
Weight		160 g	
Voltages "Un"		VDC	Code
-10% to +10% of the Un		24 V	C2

To Order a Coil choose Coil Ref + Voltage Code, example: 483816 for 24 VDC = 483816C2

More voltage possibilities can be found in the table of voltage codes at the end of the coil section.

These coils must be used with suitable housings, see example below:

Please use the coil assembly kit Ref. 2995.

It is composed of a nameplate giving details of the valve type, a round washer and a nut to ensure the fixing between 32 mm coil and the valve.

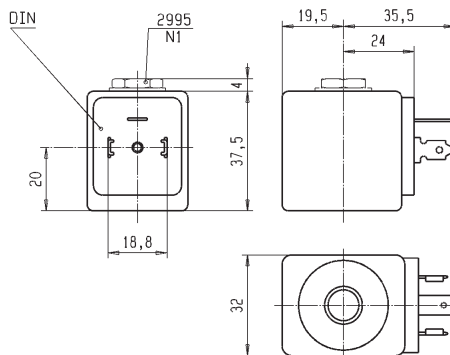

**COIL GROUP**
**1.1**
**COILS FOR  
DIN PLUG CONNECTION**

**COILS 22 mm**

This coil can be mounted with every Parker solenoid valves corresponding to the specified Coil Group.

See column "Coil Group" within valve pages.

This is an encapsulated assembly comprising a coil, integral magnetic iron path and snap-on plug connection.

The synthetic material encapsulation provides an effective compact housing, offering full protection against dust, oil, water, etc.

Ease of mounting in confined space - offers shock and corrosion protection - simplifies conversion of existing equipment to other requirements, etc.

Coils conform to the IEC/CENELEC safety standards and complies with European low-voltage directive.

DIN plug connector to be ordered separately (see coil accessories section)



Specification		Low power			High power				
Ref. (without DIN plug) Ref. (with DIN plug)		488980			481180				
Coil Group		1.1							
Degree of protection		IP65 according to IEC / EN 60529 standards (with DIN plug).							
Class of insulation		F 155°C							
Electrical connection		The coil is connected with a 2 P + E plug according to EN 175301-803 type B.							
Ambient temperature		-40°C to +50°C The application is limited also by the temperature range of the valve.							
Elect. Power	DC	Pn (hot)	2.5 W			5 W			
		P (cold) 20°C	3 W			6.5 W			
	AC	Pn (holding)	2 W			4 W			
		Attraction cold	5.7 VA (2.5 W)			8.9 VA (5 W)			
Weight		100 g with DIN Plug							
Voltages "Un"		VAC/Hz	Code	VDC	Code	VAC/Hz	Code	VDC	Code
-10% to +10% of the Un		24/50	A2	24	C2	24/50	A2	24	C2
		48/50	A4	48	C4	110/50-115/50	0A		
		110/50-115/50	0A	110	C5	220/50-230/50	3D		
		220/50-230/50	3D						

To Order a Coil choose Coil Ref + Voltage Code, example: 488980 for 24 VDC = 488980C2

More voltage possibilities can be found in the table of voltage codes at the end of the coil section.

These coils must be used with suitable housings, see example below:

Please use the coil assembly kit Ref. 8993.

It is composed of a nameplate with the details of the valve type, a washer and a nut to secure the 22 mm coil to the valve.

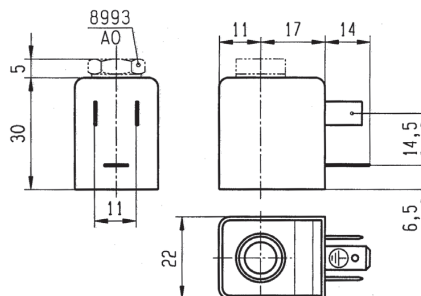
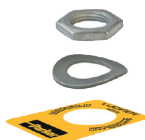

## COILS

### COIL GROUP

# 1.1

## COILS FOR DIN PLUG CONNECTION



### COIL 22 mm

These coils can be mounted with every Parker solenoid valves corresponding to the specified Coil Group.

See column "Coil Group" within valve pages.

This coil is designed for valves equipped with a miniature tube assembly (2000 series valves). This is an encapsulated assembly comprising a coil, integral magnetic iron path and snap-on plug connection.

The synthetic material encapsulation provides an effective compact housing, offering full protection against dust, oil, water, etc.

Ease of mounting in confined space - offers shock and corrosion protection - simplifies conversion of existing equipment to other requirements, etc.

Coil conforms to the IEC/CENELEC safety standards and complies with European low-voltage directive.



Specification		Standard (only if used with 321K, 121M, 131M valves)			
Reference (without DIN plug)		492912			
Reference (with DIN plug)					
Coil Group		1.1			
Degree of protection		IP65 according to IEC / EN 60529 standards (with DIN plug).			
Class of insulation		A 105°C for UL/CSA			
Electrical connection		The coil is connected with a 2 P + E plug according to EN 175301-803 type B.			
Ambient temperature		-40°C to +50°C The application is limited also by the temperature range of the valve.			
Elect. Power	DC	Pn (hot)	4 W		
		P (cold) 20°C	4.5 W		
	AC	Pn (holding)	3 W		
		Attraction cold	7.5 VA (4 W)		
Weight		100 g with DIN Plug			
Voltages "Un"		VAC/Hz	Code	VDC	Code
- 15% to +10% of the Un		115/50-120/60	P8	24	C2

To Order a Coil choose Coil Ref + Voltage Code, example: 492912 for 24 VDC = 492912C2

More voltage possibilities can be found in the table of voltage codes at the end of the coil section.

These coils must be used with suitable housings, see example below:

Please use the coil assembly kit Ref. 8993.

It is composed of a nameplate giving details of the valve type, a round washer and a nut to ensure the fixing between 22 mm coil and the valve.

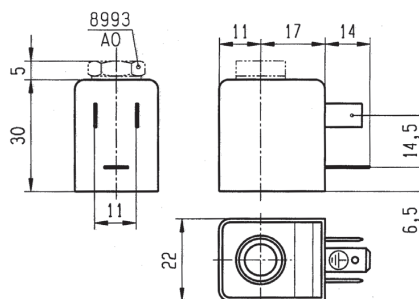
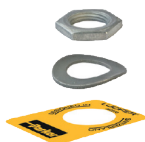

**COIL GROUP**
**1.1**
**COILS FOR  
DIN PLUG CONNECTION**

**DOUBLE FREQUENCY COIL 22 mm**

This coil can be mounted with every Parker solenoid valves corresponding to the specified Coil Group.

See column "Coil Group" within valve pages.

This coil is designed for valves equipped with a miniature tube assembly (2000 series valves). This is an encapsulated assembly comprising a coil, integral magnetic iron path and snap-on plug connection.

The synthetic material encapsulation provides an effective compact housing, offering full protection against dust, oil, water, etc.

Ease of mounting in confined space - offers shock and corrosion protection - simplifies conversion of existing equipment to other requirements, etc.

Coil conforms to the IEC/CENELEC safety standards and complies with European low-voltage directive.

DIN plug connector to be ordered separately (see coil accessories section).



Specification		Double frequency	
Reference (without DIN plug)		483590	
Coil group		1.1	
Degree of protection		IP65 according to IEC / EN 60529 standards (with DIN plug).	
Class of insulation		F 155°C	
Electrical connection		The coil is connected with a 2 P + E plug according to EN 175301-803 type B.	
Ambient temperature		-40°C to +50°C The application is limited also by the temperature range of the valve.	
Elect. Power	DC	Pn (hot)	-
		P (cold) 20°C	-
	AC	Pn (holding)	3 W
		Attraction cold	7.5 VA (4 W)
Weight		100 g with DIN Plug	
Voltages "Un"		VAC/Hz	Code
-10% to +10% of the Un		24/50-60	P0
		110-115/50, 120/60	S5
		220-240/50, 240/60	S6

To Order a Coil choose Coil Ref + Voltage Code, example: 483590 for 24/50, 24/60 = 483590P0

More voltage possibilities can be found in the table of voltage codes at the end of the coil section.

These coils must be used with suitable housings, see example below:

Please use the coil assembly kit Ref. 8993.

It is composed of a nameplate giving details of the valve type, a round washer and a nut to ensure the fixing between 22 mm coil and the valve.

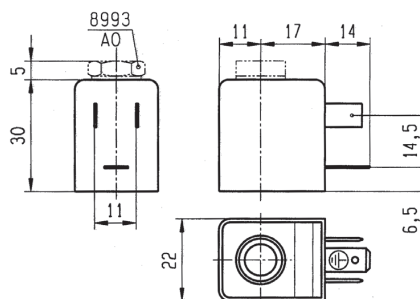
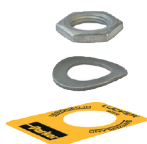

# COILS

## COIL GROUP

### 1.1

## COILS FOR DIN PLUG CONNECTION



### DOUBLE FREQUENCY COIL 22 mm

This coil can be mounted with every Parker solenoid valves corresponding to the specified Coil Group.

See column "Coil Group" within valve pages.

This coil is designed for valves equipped with a miniature tube assembly (2000 series valves). This is an encapsulated assembly comprising a coil, integral magnetic iron path and snap-on plug connection.

The synthetic material encapsulation provides an effective compact housing, offering full protection against dust, oil, water, etc.

Ease of mounting in confined space - offers shock and corrosion protection - simplifies conversion of existing equipment to other requirements, etc.

Coil conforms to the IEC/CENELEC safety standards and complies with European low-voltage directive.

DIN plug connector to be ordered separately (see coil accessories section).



Specification		Double frequency	
Reference (without DIN Plug)		488143	
Coil group		1.1	
Degree of protection		IP65 according to IEC / EN 60529 standards (with DIN plug).	
Class of insulation		F 155°C	
Electrical connection		The coil is connected with a 2 P + E plug according to EN 175301-803 type B.	
Ambient temperature		-40°C to +50°C The application is limited also by the temperature range of the valve.	
Elect. Power	DC	Pn (hot)	-
		P (cold) 20°C	-
	AC	Pn (holding)	2.5 W
		Attraction cold	-
Weight		60 g	
Voltages "Un"		VAC/Hz	Code
-10% to +10% of the Un		200/50-60	P6

To Order a Coil choose Coil Ref + Voltage Code, example: 488143 for 200/50-60 = 488143P6

More voltage possibilities can be found in the table of voltage codes at the end of the coil section.

These coils must be used with suitable housings, see example below:

Please use the coil assembly kit Ref. 8993.

It is composed of a nameplate giving details of the valve type, a round washer and a nut to ensure the fixing between 22 mm coil and the valve.

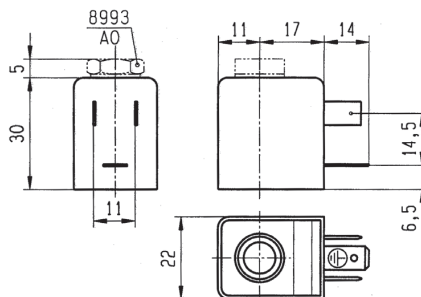
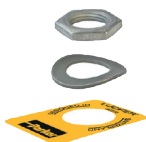

## DOUBLE FREQUENCY COIL 22 mm

This coil can be mounted with every Parker solenoid valves corresponding to the specified Coil Group.

See column "Coil Group" within valve pages.

This coil is designed for valves equipped with a miniature tube assembly (2000 series valves). This is an encapsulated assembly comprising a coil, integral magnetic iron path and snap-on plug connection.

The synthetic material encapsulation provides an effective compact housing, offering full protection against dust, oil, water, etc.

Ease of mounting in confined space - offers shock and corrosion protection - simplifies conversion of existing equipment to other requirements, etc.

Coil conforms to the IEC/CENELEC safety standards and complies with European low-voltage directive.

DIN plug connector to be ordered separately (see coil accessories section).



Specification		Double frequency			
Reference (without DIN Plug)		496131			
Coil group		1.2			
Degree of protection		IP65 according to IEC / EN 60529 standards (with DIN plug).			
Class of insulation		F 155°C			
Electrical connection		The coil is connected with a 2 P + E plug according to EN 175301-803 type B.			
Ambient temperature		-40°C to +50°C The application is limited also by the temperature range of the valve.			
Elect. Power	DC	Pn (hot)	3 W		
		P (cold) 20°C	-		
	AC	Pn (holding)	3 W		
		Attraction cold	-		
Weight		60 g			
Voltages "Un"		VAC/Hz	Code	VDC	Code
-10% to +10% of the Un		24/50-60	P0	24 V	C2
		110/50-60	P2	48 V	C4
		230/50-60	P9	110 V	C5
		48/50-60	S4		

To Order a Coil choose Coil Ref + Voltage Code, example: 496131 for 24 VDC = 496131C2

More voltage possibilities can be found in the table of voltage codes at the end of the coil section.

"The housing kit is already included in the valve reference, it is not needed to order it separately."

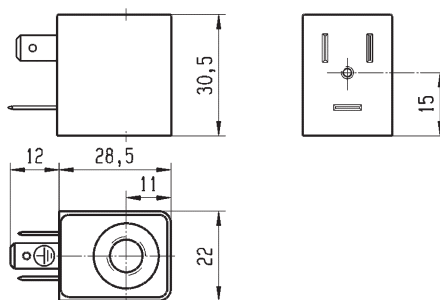

# COILS

## COIL GROUP

# 1.2

## COILS FOR DIN PLUG CONNECTION



### DOUBLE FREQUENCY COIL 22 mm

This coil can be mounted with every Parker solenoid valves corresponding to the specified Coil Group.

See column "Coil Group" within valve pages.

This coil is designed for valves equipped with a miniature tube assembly (2000 series valves). This is an encapsulated assembly comprising a coil, integral magnetic iron path and snap-on plug connection.

The synthetic material encapsulation provides an effective compact housing, offering full protection against dust, oil, water, etc.

Ease of mounting in confined space - offers shock and corrosion protection - simplifies conversion of existing equipment to other requirements, etc.

Coil conforms to the IEC/CENELEC safety standards and complies with European low-voltage directive.

DIN plug connector included.



Specification		Double frequency			
Reference		496482			
Coil group		1.2			
Degree of protection		IP65 according to IEC / EN 60529 standards (with DIN plug).			
Class of insulation		F 155°C			
Electrical connection		The coil is connected with a 2 P + E plug according to EN 175301-803 type B.			
Ambient temperature		-40°C to +50°C The application is limited also by the temperature range of the valve.			
Elect. Power	DC	Pn (hot)	3 W		
		P (cold) 20°C	-		
	AC	Pn (holding)	3 W		
		Attraction cold	-		
Weight		75 g			
Voltages "Un"		VAC/Hz	Code	VDC	Code
-10% to +10% of the Un		24/50-60	P0	24 V	C2
		110/50-60	P2	48 V	C4
		230/50-60	P9	110 V	C5
		48/50-60	S4		

To Order a Coil choose Coil Ref + Voltage Code, example: 496482 for 24 VDC = 496482C2

More voltage possibilities can be found in the table of voltage codes at the end of the coil section.

"The housing kit is already included in the valve reference, it is not needed to order it separately."

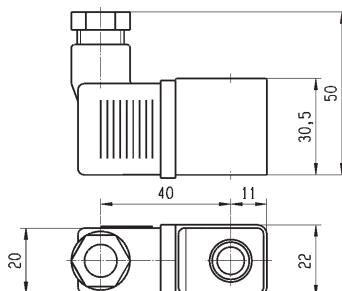

**COIL GROUP**
**10.1**
**COILS FOR  
DIN PLUG CONNECTION**

**COIL FOR OIL AND GAS 37 mm**

This coil can be mounted with every Parker solenoid valves corresponding to the specified Coil Group.

See column "Coil Group" within valve pages.

This is an encapsulated assembly comprising a coil, integral magnetic iron path and snap-on plug connection.

The synthetic material encapsulation provides an effective compact housing, offering full protection against dust, oil, water, etc.

Ease of mounting in confined space - offers shock and corrosion protection - simplifies conversion of existing equipment to other requirements, etc.

Coils conform to the IEC/CENELEC safety standards and complies with European low-voltage directive. DIN plug connector included (The AC electrical connection is delivered with a rectifier bridge).



Specification		Coil for Oil and Gas			
Reference (with DIN plug)		<b>496895</b>			
Coil group		<b>10.1</b>			
Degree of protection		IP65 according to IEC / EN 60529 standards			
Class of insulation		H 180°C			
Electrical connection		With DIN plug 492459 (AC) or 486586 (DC)			
Ambient temperature		-40°C to +50°C The application is limited also by the temperature range of the valve.			
Elect. Power	DC	Pn (hot)	8 W		
		P (cold) 20°C	-		
	AC	Pn (holding)	8 W		
		Attraction cold	-		
Weight		273 g			
Voltages "Un"		VAC/Hz	Code	VDC	Code
-10% to +10% of the Un		230/50-60	P9	24	C2
		110/50-60	P2		

**To Order a Coil choose** Coil Ref + Voltage Code, example: 496895 for 24 VDC = **496895C2**

More voltage possibilities can be found in the table of voltage codes at the end of the coil section.

The fixing nut (housing kit) is already included in the coil kit.

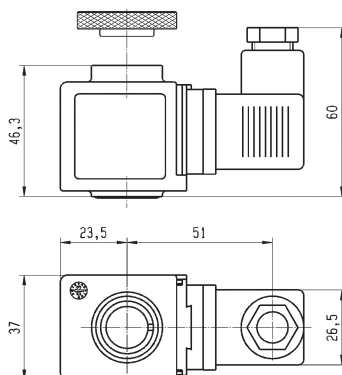

## COILS

### COIL GROUP

# 2.0/2.1

## COILS WITH FLYING LEADS



### COIL 32 mm IP67

This coil can be mounted with every Parker solenoid valves corresponding to the specified Coil Group.

See column "Coil Group" within valve pages.

This is an encapsulated assembly comprising a coil, integral magnetic iron path and snap-on plug connection.

The synthetic material encapsulation provides an effective compact housing, offering full protection against dust, oil, water, etc.

Ease of mounting in confined space - offers shock and corrosion protection - simplifies conversion of existing equipment to other requirements, etc.

Coils conform to the IEC/CENELEC safety standards and complies with European low-voltage directive.



Specification		Coil with two 500 mm flying leads			
Reference		496081			
Coil Group		2.0 / 2.1			
Degree of protection		IP67 according to IEC / EN 60529 standards			
Class of insulation		F 155°C			
Ambient temperature		-40 °C to +50°C The application is limited also by the temperature range of the valve.			
Elect. Power	DC	Pn (hot)	9 W		
		P (cold) 20°C	-		
	AC	Pn (holding)	9 W		
		Attraction cold	32 VA		
Weight		180 g			
Voltages "Un"		VAC/Hz	Code	VDC	Code
-10% to +10% of Un for AC		24/50 - 24/60	P0	24	C2
- 5 % to + 10 % for Un DC		110-115/50 - 120/60	S5	12	C1
		220-240/50 - 240/60	S6		

To Order a Coil: Coil Ref + Voltage Code, example: 496081 for 24 VDC = 496081C2

More voltage possibilities can be found in the table of voltage codes at the end of the coil section.



**COIL GROUP**
**2.0/2.1**

To assemble this coil on our solenoid valves, please order housing Ref: 2995

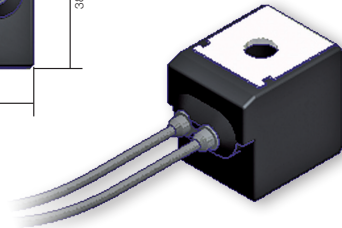
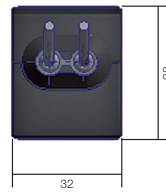
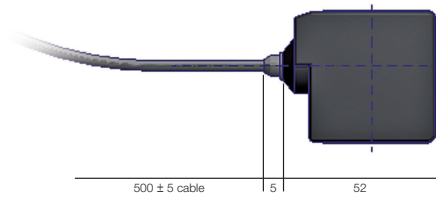

# COILS

## COIL GROUP

# 2.0/2.1

## COILS WITH SCREW TERMINALS



### STANDARD COILS 40 mm

These coils can be mounted with every Parker Solenoid Valves corresponding to the specified Coil Group.

See column "Coil Group" within valve pages.

They can be mounted with all metal housings.

The coil winding is completely encapsulated in synthetic material.

Easy mounting in confined spaces. Electrical connection with screw terminals for wire up to 1.5 mm<sup>2</sup>.

Coils conform to the IEC/CENELEC safety standards and complies with European low-voltage directive.



Specification		Standard			Double Frequency		
Reference		481000			483520		
Coil Group		2.0 / 2.1					
Class of insulation		F 155°C					
Ambient temperature		-40°C to +50°C					
		The application is limited also by the temperature range of the valve.					
Elect. Power	DC	Pn (hot)	8W		-		
		P (cold) 20°C	9W		-		
	AC	Pn (holding)	8W		9W		
		Attraction cold	32 VA (9 W)		36 VA (10 W)		
Weight		130 g			130 g		
Voltages "Un"		VAC/Hz	Code	VDC	Code	VAC/Hz	Code
-10% to +10% of the Un		24/50	A2	24	C2	24/50-60	P0
(-15 % to +5 %		48/50	A4	48	C4	220-240/50-240/60	S6
for double-frequency coil		110/50-115/50	0A	110	C5		
with voltage code		220/50-230/50	3D				
S6 if 240 V/50/Hz is used).							

To Order a Coil choose Coil Ref + Voltage Code, example: 4828 for 24 VDC = 481000C2

More voltage possibilities can be found in the table of voltage codes at the end of the coil section.

These coils must be used with suitable housings, see examples below:

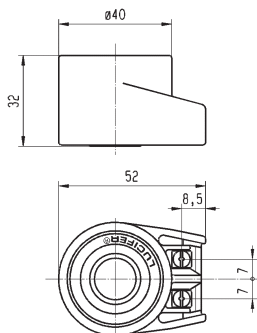

Ref. 4270 - Protection IP 44 according to IEC / EN 60529 standard (with cable gland)

Ref. 4538 - Protection IP 67 according to IEC / EN 60529 standard



**COIL GROUP**
**2.0/2.2**
**COILS WITH SCREW TERMINALS**

**HIGH POWER COILS 40 mm**

This coil can be mounted with every Parker Solenoid Valves corresponding to the specified Coil Group.

See column "Coil Group" within valve pages.

They can be mounted with all metal housings.

The coil winding is completely encapsulated in synthetic material.

Easy mounting in confined spaces. Electrical connection with screw terminals for wire up to 1.5 mm<sup>2</sup>.

Coils conform to the IEC/CENELEC safety standards and complies with European low-voltage directive.



Specification		High Power	
Reference		481044	
Coil Group		2.0 / 2.2	
Class of insulation		F 155°C	
Ambient temperature		-40°C to +50°C The application is limited also by the temperature range of the valve.	
Elect. Power	DC	Pn (hot)	-
		P (cold) 20°C	-
	AC	Pn (holding)	14 W
		Attraction cold	56 VA (20 W)
Weight		130 g	
Voltages "Un"		VAC/Hz	Code
-10% to +10% of the Un		24/50	A2
		220/50	A7
		230/50	F4

To Order a Coil choose Coil Ref + Voltage Code, example: 481044 for 24VAC/50Hz = 481044A2

More voltage possibilities can be found in the table of voltage codes at the end of the coil section.

These coils must be used with suitable housings, see examples below:

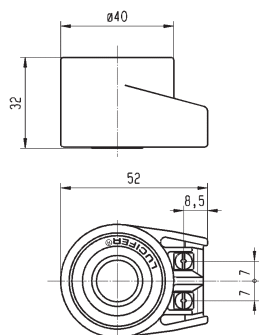

Ref. 4270 - Protection IP 44 according to IEC / EN 60529 standard (with cable gland)



Ref. 4538 - Protection IP 67 according to IEC / EN 60529 standard



## COILS

COIL GROUP  
**2.0/2.1**  
**2.2**

COILS WITH  
SCREW TERMINALS



### HIGH TEMPERATURE COILS 40 mm

These coils can be mounted with every Parker Solenoid Valves corresponding to the specified Coil Group.

See column "Coil Group" within valve pages.

They can be mounted with all metal housings.

The coil winding is completely encapsulated in synthetic material.

Easy mounting in confined spaces. Electrical connection with screw terminals for wire up to 1.5 mm<sup>2</sup>.

Coils conform to the IEC/CENELEC safety standards and complies with European low-voltage directive.



Specification		High Temperature & High Power			
Reference		486265			
Coil Group		2.0 / 2.2			
Class of insulation		H 180°C			
Ambient temperature		-40°C to +50°C The application is limited also by the temperature range of the valve.			
Elect. Power	DC	Pn (hot)	14 W		
		P (cold) 20°C	21 W		
	AC	Pn (holding)	14 W		
		Attraction cold	56 VA (20 W)		
Weight		140 g			
Voltages "Un"		VAC/Hz	Code	VDC	Code
-10% to +10% of the Un		24/50	A2	12	C1
		110/50	A5	24	C2
		220/50	A7	48	C4
		230/50	F4		

To Order a Coil choose Coil Ref + Voltage Code, example: 486265 for 24VAC/50Hz = 486265

More voltage possibilities can be found in the table of voltage codes at the end of the coil section.

These coils must be used with suitable housings, see examples below:

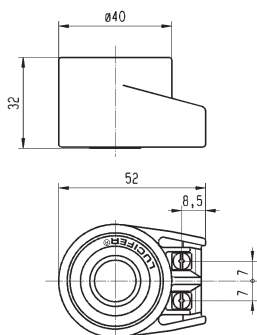

Ref. 4270 - Protection IP 44 according to IEC / EN 60529 standard (with cable gland)



Ref. 4538 - Protection IP 67 according to IEC / EN 60529 standard



**COIL GROUP**
**14.1**
**COILS WITH SCREW TERMINALS**

**HIGH TEMPERATURE & HIGH POWER COILS 40 mm OIL BURNER**

This coils can be mounted with every Parker Solenoid Valves corresponding to the specified Coil Group.

See column "Coil Group" within valve pages.

It can be mounted with all metal housings.

The coil winding is completely encapsulated in synthetic material.

Easy mounting in confined spaces. Electrical connection with screw terminals for wire up to 1.5 mm<sup>2</sup>.

Coil conform to the IEC/CENELEC safety standards and complies with European low-voltage directive.

This coil is used only in safety application according to DIN/EN/ISO 23551-1:2009-10 (Oil burners)



Specification		High Temperature & High Power	
Reference		483824	
Coil Group		14.1	
Class of insulation		H 180°C	
Ambient temperature		-40°C to +50°C The application is limited also by the temperature range of the valve.	
Elect. Power	DC	Pn (hot)	19 W
		P (cold) 20°C	19 W
	AC	Pn (holding)	19 W
		Attraction cold	56 VA (20 W)
Weight		130 g	
Voltages "Un"		VAC/Hz	Code
-10% to +10% of the Un		120/50	A6
		240/50	A8
		110/60	B5
		220/60	B7
		58/50-60/60	T6
		55/60	4J

To Order a Coil choose Coil Ref + Voltage Code, example: 483824 for 120/50 = 483824A6

More voltage possibilities can be found in the table of voltage codes at the end of the coil section.

These coils must be used with suitable housings, Ref: 8760.24 and Ref: 8520.23

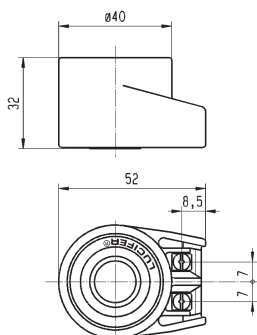

Ref. 8760.24



Ref. 8520.23



# COILS

## COIL GROUP

# 14.3

## COILS WITH SCREW TERMINALS



### HIGH TEMPERATURE & HIGH POWER COILS 40 mm OIL BURNER

This coils can be mounted with every Parker Solenoid Valves corresponding to the specified Coil Group.

See column "Coil Group" within valve pages.

It can be mounted with all metal housings.

The coil winding is completely encapsulated in synthetic material.

Easy mounting in confined spaces. Electrical connection with screw terminals for wire up to 1.5 mm<sup>2</sup>.

Coil conform to the IEC/CENELEC safety standards and complies with European low-voltage directive.

This coil is used only in safety application according to DIN/EN/ISO 23551-1:2009-10 (Oil burners)



Specification		High Temperature & High Power	
Reference		483541	
Coil Group		14.3	
Class of insulation		H 180°C	
Ambient temperature		-40°C to +50°C The application is limited also by the temperature range of the valve.	
Elect. Power	DC	Pn (hot)	20 W
		P (cold) 20°C	20 W
	AC	Pn (holding)	20 W
		Attraction cold	56 VA (20 W)
Weight		130 g	
Voltages "Un"		VAC/Hz	Code
-10% to +10% of the Un		120/50	A6
		240/50	A8
		110/60	B5
		220/60	B7
		58/50-60/60	T6
		55/60	4J

To Order a Coil choose Coil Ref + Voltage Code, example: 483541 for 120/50 = 483541A6

More voltage possibilities can be found in the table of voltage codes at the end of the coil section.

These coils must be used with suitable housings, Ref: 8760.24 and Ref: 8520.23

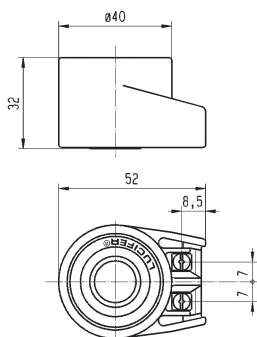

Ref. 8760.24



Ref. 8520.23



**COIL GROUP**
**2.0/2.1**
**COILS WITH SCREW TERMINALS**

**COIL DOUBLE FREQUENCY 40 mm H CLASS**

This coil can be mounted with every Parker Solenoid Valves corresponding to the specified Coil Group.

See column "Coil Group" within valve pages.

They can be mounted with all metal housings.

The coil winding is completely encapsulated in synthetic material.

Easy mounting in confined spaces. Electrical connection with screw terminals for wire up to 1.5 mm<sup>2</sup>.

Coils conform to the IEC/CENELEC safety standards and complies with European low-voltage directive.



Specification		Double Frequency 100 V - 200 V	
Reference		488553	
Coil Group		2.0/2.1	
Class of insulation		H 180°C	
Ambient temperature		-40°C to +50°C The application is limited also by the temperature range of the valve.	
Elect. Power	DC	Pn (hot)	-
		P (cold) 20°C	-
	AC	Pn (holding)	9 W
		Attraction cold	-
Weight		130 g	
Voltages "Un"		VAC/Hz	Code
-10% to +10% of the Un		100/50-60	P1
		200/50-60	P6

To Order a Coil choose Coil Ref + Voltage Code, example: 488553 for 110/50-60 = 488553P1

More voltage possibilities can be found in the table of voltage codes at the end of the coil section.

These coils must be used with suitable housings, see examples below:

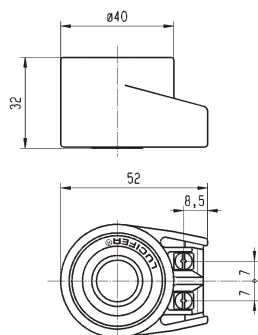

Ref. 4270 - Protection IP 44



Ref. 8520 - Protection IP 54



# COILS

## COIL GROUP

# 4.0

## COILS WITH SCREW TERMINALS



### BISTABLE COILS 40 mm FOR IMPULSE APPLICATIONS

These coils can be mounted with every Parker solenoid valves corresponding to the specified Coil Group.

See column "Coil Group" within valve pages.

These coils are specially designed for Lucifer® bistable (or impulse or magnetic latch) solenoid valves for Heating Applications.

They can be mounted only with the Lucifer® metallic housing 4269 or 4538.

The coil winding is completely encapsulated in synthetic material.

Easy mounting in confined spaces. Electrical connection with screw terminals for wire up to 1.5 mm<sup>2</sup>.

Coils conform to the IEC/CENELEC safety standards and complies with European low-voltage directive.



Specification		Bistable (Impulse)		
Reference		484990		485400
Coil Group		4.0		
Class of insulation		F 155°C		
Ambient temperature		-40°C to +50°C The application is limited also by the temperature range of the valve.		
Length of impulses		Switch on (terminals A-B): minimum 50 ms Switch off (terminals A-C): minimum 35 ms		
Electr. Power consumption	DC	Attraction (hot)	-	13 W
		Attraction (cold)	-	19 W
		Release (hot)	-	8 W
		Release (cold)	-	10 W
	AC	Attraction (hot)	11 W	-
		Attraction (cold)	17 W	-
		Release (hot)	4 W	-
		Release (cold)	7 W	-
Weight		150 g		
Voltages "Un"	VAC/Hz	Code	VDC	Code
-10% to +10% of the Un	24/50-24/60	P0	24	C2
	110-115/50-115/60	1P	48	C4
	220-230/50-60	3P	110	C5

To Order a Coil choose Coil Ref + Voltage Code, example: 485400 for 24 VDC = 485400C2

More voltage possibilities can be found in the table of voltage codes at the end of the coil section.

These coils must be used with suitable housings, see examples below:

#### DIAGRAM

##### Alternating Current

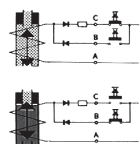

##### Direct Current

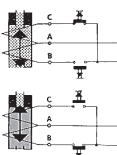

Only an electrical impulse given to terminals A-C reverses the magnetic field. This magnetic field demagnetises the reversible magnet enough to allow the return spring to bring the plunger back to its initial position and close the valve.

Ref. 4269 - Protection IP 44

Ref. 4538 - Protection IP 67



**COIL GROUP**
**13.0**
**COILS WITH ISO-DIN CONNECTORS**

**COILS 12 V - 24 V FOR TRANSPORTATION APPLICATIONS 32 mm**

These coils can be mounted with every Parker solenoid valves corresponding to the specified Coil Group.

See column "Coil Group" within valve pages.

These coils are specially designed for Lucifer® solenoid valves for Transportation Applications.

They can be mounted with the standard Lucifer® housing 2161 or customized housing.

The coil winding is completely encapsulated in epoxy. Easy mounting and dismantling in confined spaces. Bayonet twist and lock coupling for tight, vibration resistant connection.

Coils conform to the IEC/CENELEC safety standards and complies with European low-voltage directive.



Specification		Transportation			
Reference		496193 with diode		495294 without diode	
Coil Group		13.0			
Degree of protection		IP69K for DIN 400050 part 9			
Ambiant temperature		- 40°C to +120°C The application is limited also by the temperature range of the valve and duty cycle of the valve.			
Insulation Class		F 155°C			
Electrical connection		ISO 15170-A1-2.3-Sn/K2		DIN 72585-A3-2.1	
Elect. Power	DC	Pn (hot)	9 w		
		P (cold) 20°C	-		
	AC	Pn (holding)	-		
		Attraction cold	-		
Weight		147 g			
Voltages "Un"		VDC	Code	VDC	Code
- 30% to + 30% of the Un		12	C1	12	C1
		24	C2	24	C2

To Order a Coil choose Coil Ref + Voltage Code, example: 496193 for 24 VDC = 496193C2

These coils must be used with suitable housings Ref.2168 for 12Vdc and 2169 for 24 VDC.

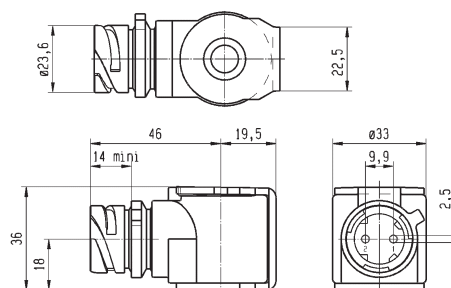
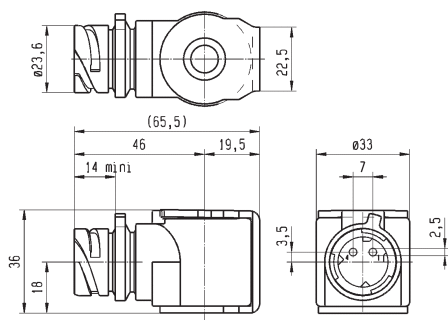

**EXPLOSION PROOF  
ELECTRICAL PARTS**



## TABLE OF CONTENT

### INTRODUCTION

Index for Explosion Proof Electrical Parts .....	414
List of Coil Groups .....	411

### COILS

Coils for DIN plug connection .....	418
Coils with flying leads .....	432
Coils with screw terminal .....	434
Coils with ISO-DIN connector .....	441

### EXPLOSION PROOF ELECTRICAL PARTS

Level of protection "nAc nCc" .....	445
Level of protection "db" .....	452
Level of protection "mb" .....	453
Level of protection "db mb" .....	457
Level of protection "eb" .....	462
Level of protection "eb mb" .....	463
Level of protection "ia" .....	466

<b>HOUSINGS</b> .....	474
-----------------------	-----

<b>COIL ACCESSORIES</b> .....	478
-------------------------------	-----

<b>EXPLOSIVE ENVIRONMENTS</b> .....	480
-------------------------------------	-----

### COIL APPENDICES

Guidance chart for IS-Barriers .....	490
--------------------------------------	-----



**EXPLOSION PROOF  
ELECTRICAL PARTS**

**COIL GROUP**

**1.1**

**ELECTRICAL PARTS  
"nAc nCc"**



**ZONE 2/22**

**ELECTRICAL PART LOW POWER 22 mm**

This coil can be mounted with every Parker ATEX solenoid valves corresponding to the specified Coil Group.

See column "Coil Group" within valve pages.

**Application:**

Control of solenoid valves in dangerous areas where explosion-proof protection Ex nAc nCc IIC T5 is required.

**Benefits:**

The synthetic material encapsulation of the coil provides an effective compact housing, offering full protection against dust, oil, water, etc. Small size for ease of mounting in confined spaces.



<b>Reference</b>		<b>495865</b>			
<b>Certificate</b>		<b>LCIE 05 ATEX 6003 X</b>			
<b>Coil Group</b>		<b>1.1</b>			
<b>Type of protection</b>	<b>Gas</b>	II 3 G Ex nAc nCc IIC T5			
	<b>Dust</b>	II 3 D - Ex tc IIIC - T 95°C			
<b>Degree of protection</b>		<b>IP65</b> (with plug) according to IEC/EN 60529 Standards			
<b>Ambiant temperature</b>		-40°C to +50°C The application is limited also by the temperature range of the valve.			
<b>Insulation Class</b>		F 155°C			
<b>Electrical connection</b>		These coils with connection 2P + G - when mounted together with the supplied Pg 9 plug (delivered with the coil),			
<b>Elect. Power</b>	<b>DC</b>	Pn (hot)	2.5 W		
		P (cold) 20°C	3 W		
	<b>AC</b>	Pn (holding)	2 W		
		Attraction cold	5.7 VA (2.5 W)		
<b>Weight</b>		120 g			
<b>Voltages "Un"</b>		<b>VAC/Hz</b>	<b>Code</b>	<b>VDC</b>	<b>Code</b>
-10% to +10% of the Un		24/50	A2	24	C2
		110/50-115/50	0A		
		220/50-230/50	3D		

To Order a Coil choose Coil Ref + Voltage Code, example: 495865 for 24 VDC = 495865C2

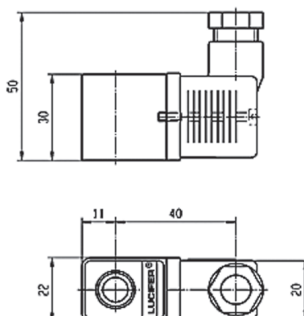

**COIL GROUP**

# 1.2

## ELECTRICAL PARTS "nAc nCc"

**ZONE 2/22**

### ELECTRICAL PART DOUBLE FREQUENCY 22 mm

This coil can be mounted with every Parker ATEX solenoid valves corresponding to the specified Coil Group.

See column "Coil Group" within valve pages.

**Application:**

Control of solenoid valves in dangerous areas where explosion-proof protection Ex nAc nCc IIC T5 is required.

**Benefits:**

The synthetic material encapsulation of the coil provides an effective compact housing, offering full protection against dust, oil, water, etc.  
Small size for ease of mounting in confined spaces.



Specification		Double Frequency			
Reference		496637			
Certificate		ATEX			
Coil group		1.2			
Type of protection	Gas	Ex nAc nCc IIC T5			
	Dust	II 3 D - Ex tc III C - T 95°C			
Degree of protection		IP65 (with plug) according to IEC/EN 60529 Sandards			
Ambiant temperature		-40°C to +50°C The application is limited also by the temperature range of the valve.			
Insulation Class		F 155°C			
Elect. Power	DC	Pn (hot)	3 W		
		P (cold) 20°C	-		
	AC	Pn (holding)	3 W		
		Attraction cold	5.7 VA (2.5 W)		
Weight		75 g			
Voltages "Un"		VAC/Hz	Code	VDC	Code
-10% to +10% of the Un		24/50-60	P0	24 V	C2
		110/50-60	P2	48 V	C4
		230/50-60	P9	110 V	C5
		48/50-60	S4		

To Order a Coil choose Coil Ref + Voltage Code, example: 496637 for 24 VDC = 496637C2

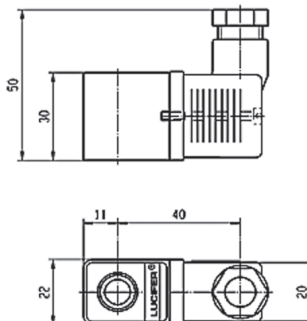

**EXPLOSION PROOF  
ELECTRICAL PARTS**

COIL GROUP

**2.0/2.1** ELECTRICAL PARTS  
"nAc nCc"



**ZONE 2/22**

**ELECTRICAL PART 32 mm**

These coils can be mounted with every Parker ATEX solenoid valves corresponding to the specified Coil Group.

See column "Coil Group" within valve pages.

Application: Control of solenoid valves in dangerous areas where explosion-proof protection Ex nAc nCc IIC T3/T4 is required.

Ease of mounting in confined space - offers shock and corrosion protection- simplifies conversion of existing equipment to other requirements, etc.

**Benefits:**

The synthetic material encapsulation of the coil provides an effective compact housing, offering full protection against dust, oil, water, etc.

Small size for ease of mounting in confined spaces.



Reference		495870				496110	
Certificate		LCIE 05 ATEX 6003 X					
Coil Group		2.0 / 2.1					
Type of protection	Gas	II 3 G Ex nAc nCc IIC T3/T4				II 3 G Ex nAc nCc IIC T3/T4	
	Dust	II 3 D - Ex tc IIIC - T195°C / T130°C				II 3 D - Ex tc IIIC - T195°C / T130°C	
Degree of protection		IP65 (with plug) according to IEC/EN 60529 Standards					
Insulation Class		F (155°C)					
Duty cycle		100%					
Ambiant temperature		-40°C to +65°C / 50°C The application is limited also by the temperature range of the valve.					
Elect. Power	DC	Pn (hot)	9 W		-		
		P (cold) 20°C	12 W		-		
	AC	Pn (holding)	8 W		9 W		
		Attraction cold	26 VA (9 W)		32 VA (10 W)		
Weight		150 g					
Voltages "Un" -10% to +10% of the Un		VAC/Hz	Code	VDC	Code	VAC/Hz	Code
		24/50	A2	24	C2	24/50-60	P0
		48/50	A4	48	C4		
		110/50	A5	110	C5	110/50-60	S5
		220-230/50	3D			220/50-60	S6

To Order a Coil choose Coil Ref + Voltage Code, example: 495870 for 24 VDC = 495870C2

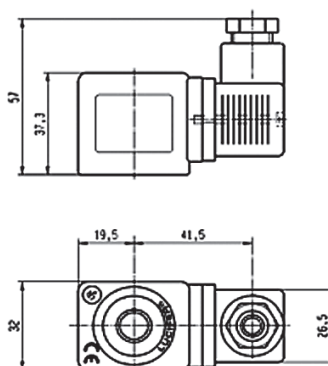

**COIL GROUP**
**6.0**
**ELECTRICAL PARTS  
"nAc nCc"**

**ZONE 2/22**
**ELECTRICAL PART LOW POWER 32 mm**

This coil can be mounted with every Parker ATEX solenoid valves corresponding to the specified Coil Group.

See column "Coil Group" within valve pages.

**Application:** Control of solenoid valves in dangerous areas where explosion-proof protection Ex nAc nCc IIC T5/T6 is required.

Ease of mounting in confined space - offers shock and corrosion protection- simplifies conversion of existing equipment to other requirements, etc.

**Benefits:**

The synthetic material encapsulation of the coil provides an effective compact housing, offering full protection against dust, oil, water, etc.

Small size for ease of mounting in confined spaces.



Reference	496125		
Certificate	LCIE 05 ATEX 6003 X		
Coil group	6.0		
Type of protection	Gas	II 3 G Ex nAc nCc IIC T5/T6	
	Dust	II 3 D Ex tc IIIc T95°C/80°C	
Degree of protection	IP65 (with plug) according to IEC/EN 60529 Standards		
Insulation Class	F (155°C)		
Duty cycle	100%		
Ambiant temperature	-40°C to +65°C / 50°C		
	The application is limited also by the temperature range of the valve.		
Elect. Power	DC	Pn (hot)	1.6 W
		P (cold) 20°C	2.1 W
	AC	Pn (holding)	-
		Attraction cold	-
Weight	150 g		
Voltages "Un"	VDC		Code
	-10% to +10% of the Un	24	C2

To Order a Coil choose Coil Ref + Voltage Code, example: 496125 for 24 VDC = 496125C2

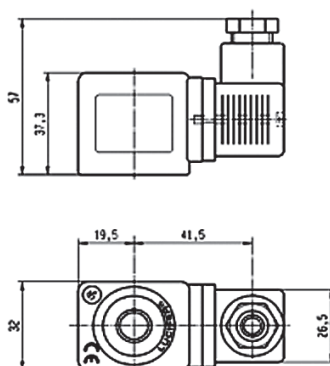

**EXPLOSION PROOF  
ELECTRICAL PARTS**

**COIL GROUP**

**3.0**

**ELECTRICAL PARTS  
"nAc nCc"**



**ZONE 2/22**

**ELECTRICAL PART 32 mm**

These coils can be mounted with every Parker ATEX solenoid valves corresponding to the specified Coil Group.

See column "Coil Group" within valve pages.

Application: Control of solenoid valves in dangerous areas where explosion-proof protection Ex nAc nCc IIC T3/T4 is required.

Ease of mounting in confined space - offers shock and corrosion protection- simplifies conversion of existing equipment to other requirements, etc.

**Benefits:**

The synthetic material encapsulation of the coil provides an effective compact housing, offering full protection against dust, oil, water, etc.

Small size for ease of mounting in confined spaces.



Specification		32 mm Coil "nAc nCc"			
Reference		495875			
Certificate		LCIE 05 ATEX 6003 X			
Coil Group		3.0			
Type of protection	Gas	II 3 G Ex nAc nCc IIC T3/T4			
	Dust	II 3 D - Ex tc IIIC - T195°C / T130°C			
Degree of protection		IP65 (with plug) according to IEC/EN 60529 Standards			
Insulation Class		F 155°C			
Duty cycle		100%			
Ambiant temperature		-40°C to +65°C / 50°C The application is limited also by the temperature range of the valve.			
Elect. Power	DC	Pn (hot)	7 W		
		P (cold) 20°C	-		
	AC	Pn (holding)	6 W		
		Attraction cold	-		
Weight		180 g			
Voltages "Un"		VAC/Hz	Code	VDC	Code
-10% to +10% of the Un		220-230/50	3D	24	C2

To Order a Coil choose Coil Ref + Voltage Code, example: 495875 for 24 VDC = 495875C2

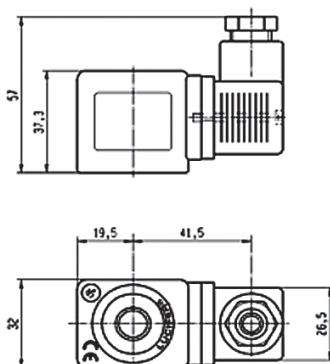

**COIL GROUP**
**2.0/2.2**
**NON ENCAPSULATED  
ELECTRICAL PARTS  
"nAc nCc"**

## ELECTRICAL PART 32 mm

This coil can be mounted with every Parker ATEX solenoid valves corresponding to the specified Coil Group.

See column "Coil Group" within valve pages.

Application: Control of solenoid valves in dangerous areas where explosion-proof protection Ex nAc nCc IIC T3 is required.

Ease of mounting in confined space - offers shock and corrosion protection - simplifies conversion of existing equipment to other requirements, etc.

### Benefits:

The synthetic material encapsulation of the coil provides an effective compact housing, offering full protection against dust, oil, water, etc.

Small size for ease of mounting in confined spaces.

**ZONE 2/22**

Specification		32 mm Coil "nAc nCc"			
Reference		495880			
Certificate		LCIE 05 ATEX 6003X			
Coil Group		2.0 / 2.2			
Type of protection	Gas	II 3 G Ex nAc nCc IIC T3			
	Dust	II 3 D - Ex tc IIIC - T195°C			
Degree of protection		IP65 (with plug) according to IEC/EN 60529 Standards			
Insulation Class		H 180°C			
Duty cycle		100%			
Ambiant temperature		-40°C to +65°C The application is limited also by the temperature range of the valve.			
Elect. Power	DC	Pn (hot)	14 W		
		P (cold) 20°C	-		
	AC	Pn (holding)	14 W		
		Attraction cold	-		
Weight		180 g			
Voltages "Un"		VAC/Hz	Code	VDC	Code
-10% to +10% of the Un		24/50	A2	24	C2
		110/50	A5		
		230/50	F4		

To Order a Coil choose Coil Ref + Voltage Code, example: 495880 for 24 VDC = 495880C2

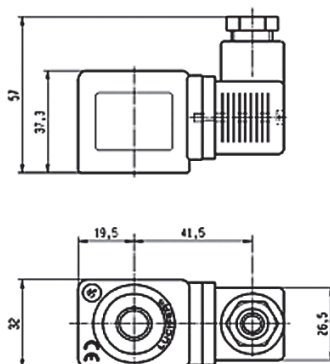

**EXPLOSION PROOF  
ELECTRICAL PARTS**

COIL GROUP

**4.0**

**INCREASED SAFETY  
ELECTRICAL PARTS  
"nAc nCc"**



**ZONE 2/22**

**495915 - ELECTRICAL PARTS 50 mm**

This coil can be mounted with every Parker ATEX solenoid valves corresponding to the specified Coil Group.

See column "Coil Group" within valve pages.

**Application:** Control of solenoid valves in dangerous areas where explosion-proof protection - Ex nAc nCc IIC T3 is required.

**Benefits:** Rotatable housing 360°, epoxy varnished steel with internal and external screw terminals for earth connection.

Small size for ease of mounting in confined space. Simplifies conversion of existing equipment to hazardous area requirements.



<b>Reference</b>		<b>495915</b>			
<b>Certificate</b>		<b>LCIE 05 ATEX 6010 X</b>			
<b>Coil group</b>		<b>4.0</b>			
<b>Type of protection</b>	<b>Gas</b>	II 3 G Ex nAc nCc IIC T3			
	<b>Dust</b>	II 3 D - Ex tc IIIC - T 195°C			
<b>Degree of protection</b>		<b>IP67</b> according to IEC/EN 60529 Standards			
<b>Ambient temperature</b>		-40°C to +65°C The application is limited also by the temperature range of the valve.			
<b>Insulation Class</b>		F 155°C			
<b>Electrical connection</b>		By special cable gland M20 x 1.5 on screw terminals for wires up to 1.5 mm <sup>2</sup> . Cable with outside diameter 6.5 mm to 13.5 mm can be simply sealed using the rubber gland with resilient sealing rings supplied			
<b>Consumation Electrique</b>	<b>AC</b>	Attraction (hot)	11 W	-	
		Attraction (cold) 20°C	17 W	-	
		Release (hot)	4 W	-	
		Release (cold) 20°C	7 W	-	
	<b>DC</b>	Attraction (hot)	-	13 W	
		Attraction (cold) 20°C	-	19 W	
		Release (hot)	-	8 W	
		Release (cold) 20°C	-	10 W	
<b>Weight</b>		320 g			
<b>Duty cycle</b>		Continuous duty solenoid (ED 100%)			
<b>Voltages "Un"</b>		<b>VAC/Hz</b>	<b>Code</b>	<b>VDC</b>	<b>Code</b>
-10% to +10% of the Un		110-115/50-60	1P	24	C2
		220-230/50-60	3P	48	C4
		48/50-60	S4		
		24/50-60	P0		

To Order a Coil choose Coil Ref + Voltage Code, example: 495915 for 24 VDC = 495915C2

Schema



As soon as an electrical impulse is given to the terminals A-B, the electromagnetical force attracts the plunger and simultaneously magnetizes a reversible permanent magnet ring. This magnet retains the plunger in place. It stays in position even without current. Only an electrical impulse given to terminals A-C reserves the magnetic field. This magnetic field demagnetises the reversible magnet enough to allow the return spring to bring the plunger back to its initial position and close the valve.

Switch: Switch on (terminals A-B): Minimum 50 ms (maximum 1 s)  
AC: Switch off (terminals A-C): Minimum 35 ms (maximum 1 s)

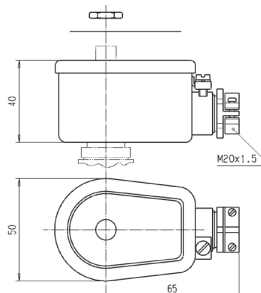

**COIL GROUP**
**2.0/2.2**
**INCREASED SAFETY  
ELECTRICAL PARTS  
"nAc nCc"**

**ZONE 2/22**

### 3.5.1 ELECTRICAL PARTS 496155

These coils can be mounted with every Parker solenoid valves corresponding to the specified Coil Group.

See column "Coil Compatibility Group" within valve pages.

**Application:** Control of solenoid valves in dangerous areas where explosion-proof protection Ex nAc nCc IIC T3 is required.

**Benefits:** Rotatable housing 360°, epoxy varnished steel with internal and external screw terminals for earth connection.

Small size for ease of mounting in confined space. Simplifies conversion of existing equipment to hazardous area requirements.



Reference		496155			
Certificate		LCIE 05 ATEX 6010 X			
Coil Group		2.0/2.2			
Type of protection	Gas	II 3 G Ex nAc nCc IIC T3			
	Dust	II 3 G D - Ex tc IIC - T 195 °C			
Degree of protection		IP67 according to IEC/EN 60529 Standards			
Ambiant temperature		-40°C to +65°C The application is limited also by the temperature range of the valve.			
Insulation Class		H 180°C			
Electrical connection		By special cable gland or M20x1.5 on screw terminals for wires up to 1.5 mm <sup>2</sup> . Cables with outside diameter 6.5 mm to 13.5 mm can be simply sealed using the rubber gland with resilient sealing rings supplied.			
Elect. Power	DC	Pn (hot)	14 W		
		P (cold) 20°C	21 W		
	AC	Pn (holding)	14 W		
		Attraction cold	56 VA (20 W)		
Weight		320 g			
Voltages "Un"		VAC/Hz	Code	VDC	Code
-10% to +10% of the Un		24/50	A2	24	C2
		230/50	F4		

To Order a Coil choose Coil Ref + Voltage Code, example: 496155 for 24VAC/50Hz = 496155A2

Fuses:

Both electrical parts have to be connected in series with a safety fuse according to IEC 60127-3.

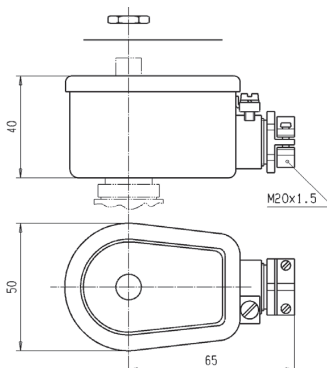

**EXPLOSION PROOF  
ELECTRICAL PARTS**

COIL GROUP

**10.3**

**FLAMEPROOF  
ELECTRICAL PARTS  
"db"**



IECEx  
certified



**ZONE 1/21**

**497105 & 497105.02 - ELECTRICAL PARTS**

These coils can be mounted with every Parker ATEX solenoid valves corresponding to the specified Coil Group.

See column "Coil Group" within valve pages.

Application: Control of solenoid valves in dangerous areas where explosion-proof protection Ex db IIC T4 / T5 / T6 is required.

Benefits: Rotatable 360°, stainless steel with internal and external screw terminals for earth connection.

Small size for ease of mounting in confined space. Simplifies conversion of existing equipment to hazardous area requirements.



Reference	497105 (M20x1.5) 497105.02 (NPT 1/2")			
Certificate	INERIS 12ATEX0041X - IECEx INE 12.0034X			
Coil Group	10.3			
Type of protection	Gas	II 2 G - Ex db IIC T4 / T5 / T6		
	Dust	II 2 D - Ex tb IIIC - 130°C / 95°C / 80°C		
Degree of protection	IP66 (with relevant cable gland) according to IEC/EN 60529 Standards			
Ambient temperature	-50°C to +80°C / +60°C / +40°C The operating temperature of the valve/coil can be limited by that of the valve			
Insulation Class	H 180°C			
Electrical connection	Electric connection is done in the connection chamber on an easily accessible connector terminals. The cable entry to the connection chamber is made through a 1/2" NPT or M20x1.5 thread in which an approved Exdb IIC cable gland must be installed.			
Electrical consumption	DC	Pn (hot)	8 W	
		P (cold) 20°C	9 W	
	AC	Pn (holding)	8 W	
		Attraction cold	9 W	
Voltage Tolerance	+/- 10% of nominal voltage			
Emergising Cuty	ED 100%			
Voltages	VAC/Hz	Code	VDC	Code
	24/50-60	P0	12	C1
	110-115 / 50-60	1P	24	C2
	220-230 / 50-60	3P	48 110	C4 C5

To Order a Coil choose Coil Ref + Voltage Code, example: 497105 for 24 VDC = 497105C2

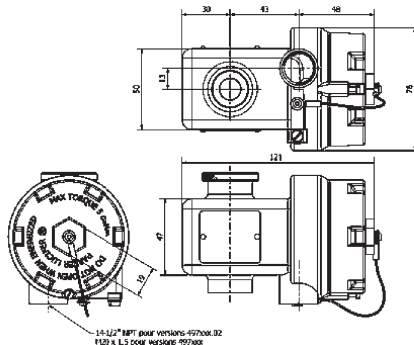

**COIL GROUP**
**1.1**
**ENCAPSULATED  
ELECTRICAL PARTS  
"mb"**

**ZONE 1/21**
**ELECTRICAL PART LOW POWER 22 mm**

These coils can be mounted with every Parker ATEX solenoid valves corresponding to the specified Coil Group.

See column "Coil Group" within valve pages.

**Application:**

Control of solenoid valves in dangerous areas where explosion-proof protection Ex mb IIC T4 / T5 is required.

**Benefits:**

Coil and magnetic circuit encapsulated in synthetic material - offering shock and corrosion protection. AC coils with integrated thermal fuse. Small size for ease of mounting in confined spaces.



Reference	482605		482606 or 482606.160*			
Certificate	LCIE 02 ATEX 6014 X - IECEx LCI 07.0026 X					
Coil Group	1.1					
Type of protection	Gas	II 2 G - Ex mb IIC T4 / T5				
	Dust	II 2 D - Ex tb IIIC - T130°C / 95°C				
Degree of protection	IP65 (with plug) according to IEC/EN 60529 Standards					
Ambiant temperature	-40°C to +65°C / +40°C			-40°C to +65°C / +35°C		
						The application is limited also by the temperature range of the valve.
Insulation Class	F 155°C					
Electrical connection	Cable connection (3 x 0.75 mm <sup>2</sup> ) encapsulated with coil, cable material according to application					
Elect. Power	DC	Pn (hot)	5 W		2.5 W	
		P (cold) 20°C	6.5 W		3 W	
	AC	Pn (holding)	4 W		2 W	
		Attraction cold	8.9 VA (5 W)		5.7 VA (2.5 W)	
Weight	150 g					
Voltages "Un"	VDC	Code	VAC/Hz	Code	VDC	Code
	-10% to +10% of the Un	12 24	C1 C2	24/50 48/50 110/50-115/50 220/50-230/50	A2 A4 0A 3D	24 48 110

To Order a Coil choose Coil Ref + Voltage Code, example: 482605 for 24 VDC = 482605C2

\* 482606.160 - 6 m cable length - available only in C2 and 3D

\* 482606 - 1.5 m cable length

**Fuses:**

Both electrical parts 482605 & 482606 have to be connected in series with a safety fuse according to CEI 60127-3. Indicating example bellow:

**482605:**

DC: 12 V, 1000 mA - 24 V, 500 mA

**482606:**

DC: 12 V, 400 mA - 24 V, 200 mA - 48 V, 100 mA - 110 V, 50 mA  
AC 50 Hz: 24 V, 250 mA - 48 V, 125 mA - 110/115 V, 63 mA - 220/230 V, 32 mA  
AC 60 Hz: 24 V, 315 mA - 110/115 V, 63 mA - 220/230 V, 32 mA

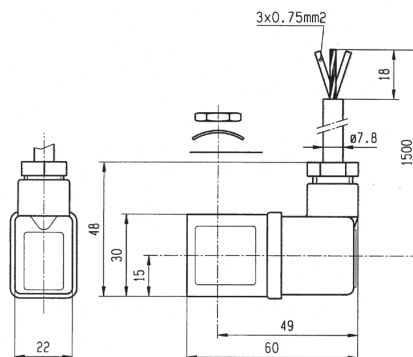

**EXPLOSION PROOF  
ELECTRICAL PARTS**

COIL GROUP

**2.0/2.1**

**ENCAPSULATED  
ELECTRICAL PARTS  
"mb"**



IECEX certified



**ZONE 1/21**

**WITH WATER PROOF METAL HOUSING 50 mm**

These coils can be mounted with every Parker ATEX solenoid valves corresponding to the specified Coil Group.

See column "Coil Group" within valve pages.

**Application:** Control of solenoid valves in dangerous areas where explosion-proof protection Ex mb IIC T4/ T5 is required.

**Benefits:** Epoxy-vernished steel housing - solenoid coil, rectifier (silicium diodes), fuse and varistor protection element are completely encapsulated in the coil housing by means of epoxy resin.

Small size for ease of mounting in confined space. Simplifies conversion of existing equipment to hazardous area requirements.



Reference	492070 ( with 3 m cable length ) 492070.60 ( with 6 m cable length )			
Certificate	LCIE 02 ATEX 6017 X - IECEX LCI 09.0024 X			
Coil Group	2.0 / 2.1			
Type of protection	Gas	II 2 G - Ex mb IIC T4/ T5		
	Dust	II 2 D - Ex tb IIIC - T130 / 95°C		
Degree of protection	IP67 according to IEC/EN 60529 standards			
Ambient temperature	-40°C to +65°C / 40°C The application is limited also by the temperature range of the valve.			
Insulation Class	H 180°C			
Electrical connection	Cable connection (3 x 1.5 mm <sup>2</sup> ) with cable gland M20 x 1.5, external earth screw connection.			
Elect. Power	DC	Pn (hot)	8 W	
		P (cold) 20°C	10 W	
	AC	Pn (holding)	9 W	
		Attraction cold	11 W	
Weight	500 g			
Voltages "Un"	VAC/Hz	Code	VDC	Code
-10% to +10% of the Un	24/50-60	P0	24	C2
	110/50-60	P2	48	C4
	220/50-60	R5	110	C5
	230/50-60	P9		
	240/50-60	Q1		

To Order a Coil choose Coil Ref + Voltage Code, example: 492070 for 24 VDC = 492070C2

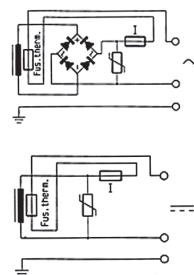
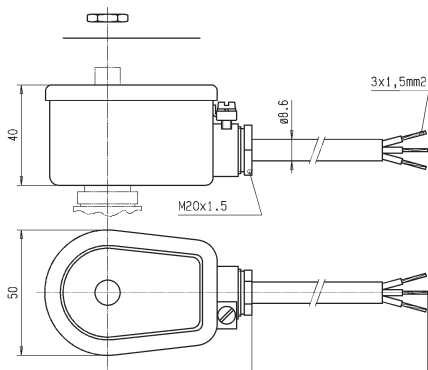

**COIL GROUP**
**2.0/2.1**
**ENCAPSULATED  
ELECTRICAL PARTS  
"mb"**

**ZONE 1/21**

## HZ10 COIL DOUBLE FREQUENCY

This coil can be mounted with every Parker ATEX solenoid valves corresponding to the specified Coil Group.  
See column "Coil Group" within valve pages.

Application: Control of solenoid valves in dangerous areas where explosion-proof protection Ex mb IIC T3/T4/T5 is required.

The coil is delivered with a 3m cable.



Specification		Double Frequency			
Reference		HZ10			
Certificate		LCIE 02 ATEX 6020 X - IECEx LCI 08.0027 X			
Coil Group		2.0 / 2.1			
Type of protection	Gas	II 2 G - Ex mb IIC T3/T4/T5			
	Dust	II 2 D - Ex tb IIIC T195°C / 130°C / 95°C			
Degree of protection		IP65 (with plug) according to IEC/EN 60529 Standards			
Ambient temperature		-40°C to +80°C / 65°C / 40°C The application is limited also by the temperature range of the valve.			
Insulation Class		H 180°C			
Duty cycle		100% continuous			
Electrical connection		Cable connection (3 x 1.5 mm <sup>2</sup> ) with cable gland M20 x 1.5, external earth screw connection.			
Elect. Power	DC	Pn (hot)	8 W		
		P (cold) 20°C	-		
	AC	Pn (holding)	8 W		
		Attraction cold	-		
Weight		299 g			
Voltages "Un"		VAC/Hz	Code	VDC	Code
-10% to +10% of the Un		24/60	B2	12	C1
		110/50-120/60	P3	24	C2
		220/50-240/60	Q3	120	C6

To Order a Coil choose Coil Ref + Voltage Code, example: HZ10 for 24 VDC = HZ10C2

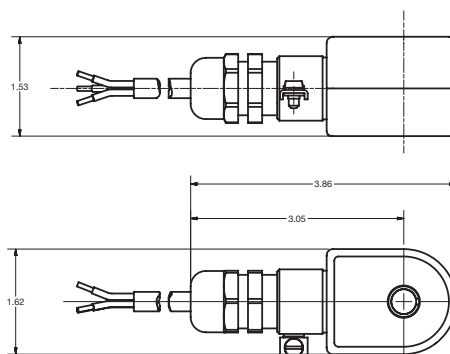

Dimensions in Inches.



**EXPLOSION PROOF  
ELECTRICAL PARTS**

**COIL GROUP  
2.0/2.2**

**ENCAPSULATED  
ELECTRICAL PARTS  
"mb"**



**ZONE 1/21**

**HZ11 COIL DOUBLE FREQUENCY**

This coil can be mounted with every Parker ATEX solenoid valves corresponding to the specified Coil Group.

See column "Coil Group" within valve pages.

Application: Control of solenoid valves in dangerous areas where explosion-proof protection Ex mb IIC T3/T4/T5 is required.

The coil is delivered with a 3m cable.



Specification		Double Frequency			
Reference		HZ11			
Certificate		LCIE 02 ATEX 6020 X - IECEx LCI 08.0027 X			
Coil Group		2.0 / 2.2			
Type of protection	Gas	II 2 G - Ex mb IIC T3/T4/T5			
	Dust	II 2 D - Ex tb IIIC T195°C / 130°C / 95°C			
Degree of protection		IP65 (with plug) according to IEC/EN 60529 Standards			
Ambient temperature		-40°C to + 65°C / 40°C The application is limited also by the temperature range of the valve..			
Insulation Class		H 180 °C			
Duty cycle		100% continuous			
Elect. Power	DC	Pn (hot)	14 W		
		P (cold) 20°C	-		
	AC	Pn (holding)	14 W		
		Attraction cold	-		
Weight		299 g			
Voltages "Un"		VAC/Hz	Code	VDC	Code
-10% to +10% of the Un		24/60	B2	12	C1
		110/50-120/60	P3	24	C2
		220/50-240/60	Q3	120	C6

To Order a Coil: Coil Ref + Voltage Code, example: HZ11 for 24 VDC = HZ11C2

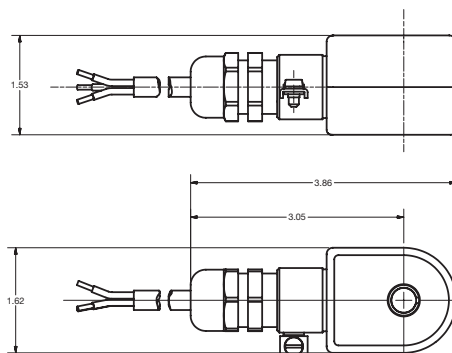

Dimensions in Inches.



**COIL GROUPS**
**6.0**
**FLAME PROOF ENCAPSULATED  
ELECTRICAL PARTS  
"db mb"**

**495900 - LOW POWER ELECTRICAL PARTS 37 mm**

This coil can be mounted with every Parker ATEX solenoid valves corresponding to the specified Coil Group.  
See column "Coil Group" within valve pages.

**Application:** Control of solenoid valves in dangerous areas where explosion-proof protection Ex db mb IIC T4 to T6 Gb is required.

**Benefits:** Rotatable 360° fibreglass-reinforced plastic housing (class H). Solenoid coil, rectifier (silicium diodes), fuses and varistor protection are completely encapsulated into the coil housing by epoxy resin for shock and corrosion protection.

The plastic housing is delivered with M20 x 1.5 cable gland certified together with the equipment. Small size for ease of mounting in confined space.

**ZONE 1/21**

Reference		495900 (VAC)	495900 (VDC)		
ATEX/IECEx Certificates		IMQ 22 ATEX 020 X - IECEx IMQ 22.0002 X			
KCs Certificates		KTL 24-KA4B0-0457X / 0458X	KTL 24-KA4B0-0459X / 0460X		
CCC Certificate		CCC 2021322307004013			
Coil Group		6.0			
Type of protection	II 2 G	Ex db mb IIC T4 / T5 / T6 Gb	Ex db mb IIC T4 / T5 / T6 Gb		
	II 2 D	Ex tb IIIC - 130°C / 95°C / 80°C Db	Ex tb IIIC - T130°C / 95°C / 80°C Db		
Degree of protection		IP66/IP67 according to IEC/EN 60529 Standards			
Ex d enclosure		The «Ex d» enclosure can withstand a maximum pressure of 58 bar			
Environmental temperature		-40°C to +80°C / 60°C / 40°C	-40°C to +80°C / 65°C / 55°C		
Insulation Class		H (180°C)			
Electrical connection		Electric connection is done in the connection box on easily accessible connector terminal. The introduction of the cable (Ø min 5 mm, Ø max 11 mm, section max. 2.5 mm², 2P+E) in the connection box passes by the built-in M20x1.5 cable gland			
Elect. Power	DC	Pn (hot)	-	2 W	
		P (cold) 20°C	-	2.5 W	
	AC	Pn (holding)	2.5 W	-	
		Attraction cold	3 W	-	
Voltages "Un"		VAC/Hz	Code	VDC	Code
Voltage tolerance: +/- 10% Un		24/50	A2	12	C1
		48/50	A4	24	C2
		115/50	E5	48	C4
		230/50	F4	110	C5
		115/60	K8		
		240/60	B8		

**To Order a Coil:** Coil Ref + Voltage Code 495900 24VDC = 495900C2

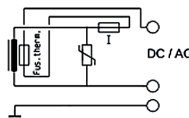
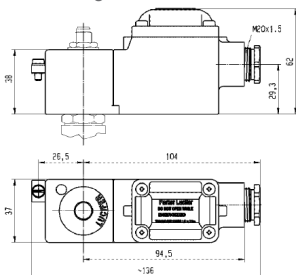

## EXPLOSION PROOF ELECTRICAL PARTS

### COIL GROUPS

# 2.0/2.1

## FLAME PROOF ENCAPSULATED ELECTRICAL PARTS "db mb"



ZONE 1/21

## 495905 - ELECTRICAL PARTS 37 mm

These coils can be mounted with every Parker ATEX solenoid valves corresponding to the specified Coil Group.  
See column "Coil Group" within valve pages.

**Application:** Control of solenoid valves in dangerous areas where explosion-proof protection Ex db mb IIC T4 Gb is required.

**Benefits:** Rotatable 360° fibreglass-reinforced plastic housing (class H). Solenoid coil, rectifier (silicium diodes), fuses and varistor protection are completely encapsulated into the coil housing by epoxy resin for shock and corrosion protection.

The plastic housing is delivered with M20 x 1.5 cable gland certified together with the equipment. Small size for ease of mounting in confined space.



<b>Reference</b>	<b>495905 (VAC)</b>		<b>495905 (VDC) &amp; 495905.05**</b>	
<b>ATEX/IECEx Certificates</b>	<b>IMQ 22 ATEX 020 X - IECEx IMQ 22.0002 X</b>			
<b>KCs Certificates</b>	<b>KTL 24-KA4B0-0457X / 0458X</b>		<b>KTL 24-KA4B0-0459X / 0460X</b>	
<b>CCC Certificate</b>	<b>CCC 2021322307004013</b>			
<b>JPEX Certificate*</b>	<b>DEK24, 0036X</b>			
<b>Coil Group</b>	<b>2.0 / 2.1</b>			
<b>Type of protection</b>	<b>II 2 G</b>	<b>Ex db mb IIC T4 Gb</b>		
	<b>II 2 D</b>	<b>Ex tb IIIC - 130°C Db</b>		
<b>Degree of protection</b>	<b>IP66/IP67</b> according to IEC/EN 60529 Standards			
<b>Ex d enclosure</b>	The «Ex d» enclosure can withstand a maximum pressure of 58 bar			
<b>Environmental temperature</b>	-40°C to +80°C The thermal class depends on the environmental temperature as shown above The application is limited also by the temperature range of the valve			
<b>Insulation Class</b>	<b>H (180°C)</b>			
<b>Electrical connection</b>	Electric connection is done in the connection box on easily accessible connector terminal. The introduction of the cable (Ø min 5 mm, Ø max 11 mm, section max. 2.5 mm², 2P+E) in the connection box passes by the built-in M20x1.5 cable gland			
<b>Elect. Power</b>	<b>DC</b>	<b>Pn (hot)</b>	<b>8 W</b>	
		<b>P (cold) 20°C</b>	<b>9 W</b>	
	<b>AC</b>	<b>Pn (holding)</b>	<b>8 W</b>	
		<b>Attraction cold</b>	<b>9 W</b>	
<b>Voltages "Un"</b>	<b>VAC/Hz</b>	<b>Code</b>	<b>VDC</b>	<b>Code</b>
	24/50	A2	24	C2
	48/50	A4	48	C4
Voltage tolerance: +/- 10% Un	115/50	E5	110	C5
	230/50	F4		
	115/60	K8		
	240/60	B8		

**To Order a Coil choose Coil Ref + Voltage Code, example: 495905 for 24VDC = 495905C2**

\*JPEX for 495905C2, C4, C5 only  
\*\* 495905.05 available only in C4

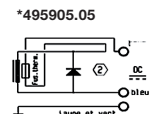
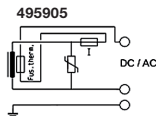
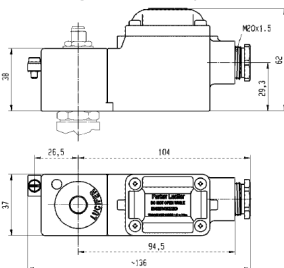

**COIL GROUP**  
**10.2/10.1** **FLAME PROOF ENCAPSULATED  
ELECTRICAL PARTS**  
"db mb"



## 496555 & 496560 - ELECTRICAL PARTS 37 mm

These coils can be mounted with every Parker ATEX solenoid valves corresponding to the specified Coil Group.  
See column "Coil Group" within valve pages.

**Application:** Control of solenoid valves in dangerous areas where explosion-proof protection Ex db mb IIC T4 to T6 Gb is required.

**Benefits:** Rotatable 360° fibreglass-reinforced plastic housing (class H). Solenoid coil, rectifier (silicium diodes), fuses and varistor protection are completely encapsulated into the coil housing by epoxy resin for shock and corrosion protection.

The plastic housing is delivered with M20 x 1.5 cable gland certified together for the equipment. Small size for ease of mounting in confined space.



ZONE 1/21

Reference		496555				496560			
ATEX/IECEX Certificates		IMQ 22 ATEX 020 X – IECEX IMQ 22.0002 X							
KCs Certificates		KTL 24-KA4B0-0465X / 0466X / 0467X / 0468X							
CCC Certificate		CCC 2021322307004013							
Coil Group		10.2				10.1			
Type of protection	II 2 G	Ex db mb IIC T4 / T5 / T6 Gb				Ex db mb IIC T4 Gb			
	II 2 D	Ex tb IIC - T130°C / 95°C / 80°C Db				Ex tb IIC - T130°C Db			
Degree of protection		IP66/IP67 according to IEC/EN 60529 Standards							
Ex d enclosure		The «Ex d» enclosure can withstand a maximum pressure of 58 bar							
Environmental temperature		-40°C to +65 / 50 / 35°C				-40°C to +65°C			
Insulation Class		H (180°C)							
Electrical connection		Electric connection is done in the connection box on easily accessible connector terminal. The introduction of the cable (Ø min 5 mm, Ø max 11 mm, section max. 2.5 mm², 2P+E) in the connection box passes by the built-in M20x1.5 cable gland							
Elect. Power	DC	Pn (hot)	-	6 W	-	-	8 W	-	10.5 W
		P (cold) 20°C	-	7.5 W	-	-	10.5 W	-	-
	AC	Pn (holding)	6 W	-	-	8 W	-	-	-
		Attraction cold	7.5 W	-	-	10.5 W	-	-	-
Voltages "Un"		VAC/Hz	Code	VDC	Code	VAC/Hz	Code	VDC	Code
-10% to +10% of the Un		230/50-60	P9	24	C2	230/50-60	P9	24	C2
		110/50-60	P2	48	C4	110/50-60	P2	48	C4
		24/50-60	P0	110	C5	24/50-60	P0	110	C5
		48/50-60	S4	-	-	48/50-60	S4	-	-

**To Order a Coil choose** Coil Ref + Voltage Code, example: 496555 for 24VDC = 496555C2

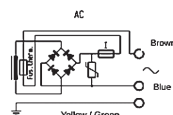
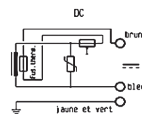
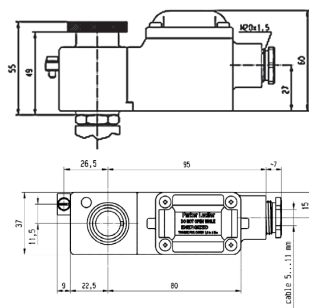

**EXPLOSION PROOF  
ELECTRICAL PARTS**

COIL GROUP

**10.2/10.1**

**FLAME PROOF ENCAPSULATED  
ELECTRICAL PARTS  
"db mb"**



**ZONE 1/21**

**496700 & 496800 - ELECTRICAL PARTS 37 mm**

These coils can be mounted with every Parker ATEX solenoid valves corresponding to the specified Coil Group.  
See column "Coil Group" within valve pages.

**Application:** Control of solenoid valves in dangerous areas where explosion-proof protection Ex db mb IIC T4 to T6 Gb is required.

**Benefits:** Rotatable 360° fibreglass-reinforced plastic housing (class H). Solenoid coil, rectifier (silicium diodes), fuses and varistor protection are completely encapsulated into the coil housing by epoxy resin for shock and corrosion protection.

The plastic housing is delivered with 1/2" NPT or M20 x 1.5 threaded hole for wide range of cable glands. Small size for ease of mounting in confined space.



Reference		496700 or 496700.02 (NPT)				496800 or 496800.02 (NPT)			
ATEX/IECEx Certificates		IMQ 22 ATEX 020 X – IECEx IMQ 22.0002 X							
KCs Certificates		KTL 24-KA4B0-0461X / 0462X / 0463X / 0464X							
CCC Certificate		CCC 2021322307004013							
Coil Group		10.2				10.1			
Type of protection	II 2 G	Ex db mb IIC T4 / T5 / T6 Gb				Ex db mb IIC T4 Gb			
	II 2 D	Ex tb IIIC - T130 / 95 / 80°C Db				Ex tb IIIC - T130°C Db			
Degree of protection		IP66/IP67 according to IEC/EN 60529 Standards							
Environmental temperature		-40°C to +35°C / +50°C / +65°C				-40°C to +65°C			
		The thermal class depends on the environmental temperature as shown above The application is limited also by the temperature range of the valve							
Insulation Class		H (180°C)							
Electrical connection		Electric connection is done in the connection box on easily accessible connector terminals. The introduction of the cable (Ø min 5 mm, Ø max 11 mm, section max. 2.5 mm², 2P+E) in the connection box passes by the M20x1.5 (or ½" NPT for .02 models) cable gland (not included).							
Elect. Power	DC	Pn (hot)	-	6 W	-	-	8 W	-	10.5 W
		P (cold) 20°C	-	7.5 W	-	-	10.5 W	-	-
	AC	Pn (holding)	6 W	-	-	8 W	-	-	-
		Attraction cold	7.5 W	-	-	10.5 W	-	-	-
Voltages "Un"		VAC/Hz	Code	VDC	Code	VAC/Hz	Code	VDC	Code
-10% to +10% of the Un		230/50-60	P9	24	C2	230/50-60	P9	24	C2
		110/50-60	P2	48	C4	110/50-60	P2	48	C4
		24/50-60	P0	110	C5	24/50-60	P0	110	C5
		48/50-60	S4	-	-	48/50-60	S4	-	-

To Order a Coil choose Coil Ref + Voltage Code, example: 496700 for 24VDC = 496700C2

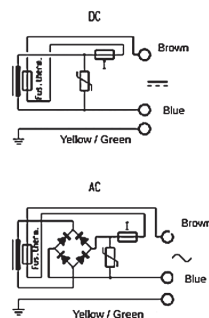
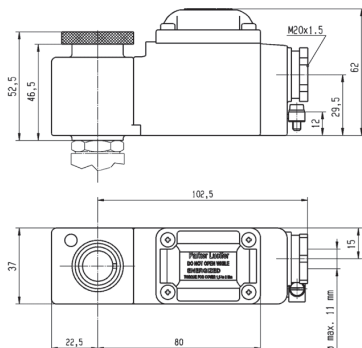

**COIL GROUP**
**2.0/2.1**
**FLAME PROOF ENCAPSULATED  
ELECTRICAL PART  
"db mb"**

## 493640 OR HZ09 - ELECTRICAL PARTS

This coil can be mounted with every Parker ATEX solenoid valves corresponding to the specified Coil Group.

See column "Coil Group" within valve pages.

Application: Control of solenoid valves in dangerous areas where explosion-proof protection Ex db mb IIC T4/T5 is required.

Benefits: Metal armature encapsulated in synthetic material provides high shock and corrosion protection.

Small size for ease of mounting in confined space.

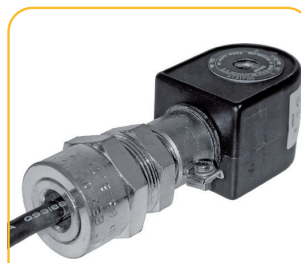
**ZONE 1/21**

Reference	493640 493640.60*			
Certificate	LCIE 02 ATEX 6009 X			
Coil Group	2.0 / 2.1			
Type of protection	Gas	II 2 G Ex db mb IIC T4/T5		
	Dust	II 2 D - Ex tb IIIC - T130°C / T95°C		
Degree of protection	IP65 according to IEC/EN 60529 Standards			
Ambiant temperature	-40°C +75°C / +40°C The application is limited also by the temperature range of the valve.			
Class of insulation	F (155 °)			
Electrical connection	Special "Ex db" cable gland, galvanized steel, with EPDM sealing. (EPR) cable, outside diameter 7.3 ± 0.5 mm and 3000 mm long.			
Elect. Power	DC	Pn (hot)	8 W	
		P (cold) 20°C	9 W	
	AC	Pn (holding)	8 W	
		Attraction cold	32 VA (9 W)	
Weight	500 g			
Voltages "Un"	VAC/Hz	Code	VDC	Code
- 15% to +10% of the Un	110/50	A5	24	C2
	110-120/50-60	P3	48	C4
	220-240/50-60	Q3	120	C6

To Order a Coil choose Coil Ref + Voltage Code, example: 493640 for 24 VDC = 493640C2

\* 493640.60 - 6 m cable length - Available only in C2

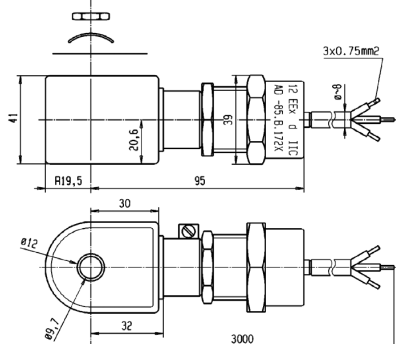

### Fuses

This electrical part is equipped with a standard thermal cut-off fuse on all models and voltages

This electrical part must be connected in series with a safety fuse according to IEC 60127-3.

DC: 24V, 400 mA

AC: 110/50-120/60, 200 mA  
220/50-240/60, 100 mA  
230/50, 95 mA



**EXPLOSION PROOF  
ELECTRICAL PARTS**

COIL GROUP

**2.0/2.1**

**INCREASED SAFETY  
ELECTRICAL PARTS  
"eb"**



**ZONE 1/21**

**483371 & 494040 - ELECTRICAL PARTS 50 MM**

This coil can be mounted with every Parker ATEX solenoid valves corresponding to the specified Coil Group.

See column "Coil Group" within valve pages.

**Application:** Control of solenoid valves in dangerous areas where explosion-proof protection Ex eb IIC T3 or T4 is required.

**Benefits:** Rotatable housing 360°, epoxy varnished steel with internal and external screw terminals for earth connection.

Small size for ease of mounting in confined space. Simplifies conversion of existing equipment to hazardous area requirements.



Reference		483371			494040				
Certificate		LCIE 02 ATEX 6011 X			LCIE 02 ATEX 6013 X				
Coil Group		2.0 / 2.1							
Type of protection	Gas	II 2 G - Ex eb IIC T4			II 2 G - Ex eb IIC T3 / T4				
	Dust	II 2 D - Ex tb IIIC - T130°C			II 2 D - Ex tb IIIC - T195°C / T130 °C				
Degree of protection		IP67 according to IEC/EN 60529 Standards							
Ambiant temperature		-40°C to +65°C The application is limited also by the temperature range of the valve.			-40°C to +90°C / to +65°C				
Class of insulation		F 155°C			H (180°)				
Electrical connection		By special cable gland or M20 x 1.5 "Ex eb" on screw terminals for wires up to 1.5 mm <sup>2</sup> . Cables with outside diameter 6.5 mm to 13.5 mm can be simply sealed using the rubber gland with resilient sealing rings supplied.							
Elect. Power	DC	Pn (hot)	8 W			8 W			
		P (cold) 20°C	9 W			9 W			
	AC	Pn (holding)	8 W			8 W			
		Attraction cold	32 VA (9 W)			32 VA (9 W)			
Weight		320 g							
Voltages "Un"		VAC/Hz	Code	VDC	Code	VAC/Hz	Code	VDC	Code
-10% to +10% of the Un		24/50	A2	24	C2	220-230/50	3D	24	C2
		48/50	A4	48	C4				
		110-115/50	0A	110	C5				
		220-230/50	3D						

To Order a Coil choose Coil Ref + Voltage Code, example: 483371 for 24 VDC = 483371C2

**Fuses:**

Both electrical parts have to be connected in series with a safety fuse according to IEC 60127-3.

**483371:**

DC: 24 V, 400 mA - 48V, 250 mA - 110 V, 100 mA  
AC 50HZ: 24 V, 630 mA - 48V, 315 mA - 110 V, 160 mA - 220/230 V, 80 mA

**494040:**

DC: 12 V, 400 mA - 24V, 200 mA - 48 V, 100 mA - 110V, 50 mA  
AC 50HZ: 24 V, 250 mA - 48V, 125 mA - 110/115 V, 63 mA - 220/230 V, 32 mA

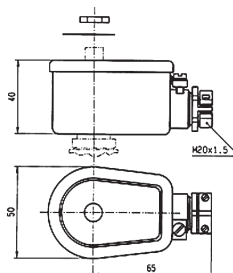

**COIL GROUP**
**10.1**
**INCREASED SAFETY  
AND ENCAPSULATED  
ELECTRICAL PARTS "eb mb"**

 IECEx  
certified

**492310 - ELECTRICAL PARTS 50 mm**

This coil can be mounted with every Parker ATEX solenoid valves corresponding to the specified Coil Group.

See column "Coil Group" within valve pages.

**Application:** Control of solenoid valves in dangerous areas where explosion-proof protection Ex eb mb II T4 to T5 is required.

**Benefits:** Rotatable 360° fibreglass-reinforced plastic housing. Solenoid coil, rectifier (silicium diodes), fuses and varistor protection are completely encapsulated into the coil housing by epoxy resin for shock and corrosion protection.

Small size for ease of mounting in confined space.

**ZONE 1/21**

Reference	492310			
Certificate	LCIE 02 ATEX 6023 X - IECEx LCI 06.0011 X			
Coil group	10.1			
Type of protection	Gas	II 2 G - Ex eb mb II T4 / T5		
	Dust	II 2 D - Ex tb IIIC - T130°C / T95°C		
Degree of protection	IP66 according to IEC/EN 60529 Standards			
Ambiant temperature	-40°C to +75°C / to +40°C The operating temperature of the valve/coil can be limited by that of the valve			
Class of insulation	H 180°C			
Electrical connection	Connection box with terminals and cable entry via gland M20 x 1.5 - Possibility for additional earth via external screw.			
Elect. Power	DC	Pn (hot)	6 W	
		P (cold) 20°C	7.5 W	
	AC	Pn (holding)	6 W	
		Attraction cold	7.5 W	
Weight	500 g			
Voltages "Un" -10% to +10% of the Un	VAC/Hz	Code	VDC	Code
	24/50-60	P0	24	C2
	48/50-60	S4	48	C4
	230/50-60	P9	110	C5

To Order a Coil choose Coil Ref + Voltage Code, example: 492310 for 24 VDC = 492310C2

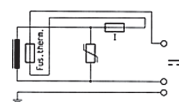
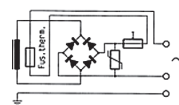
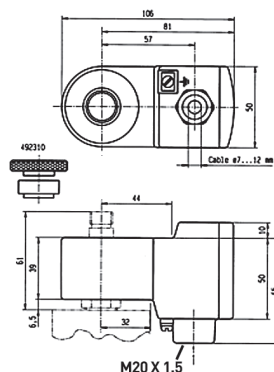

## EXPLOSION PROOF ELECTRICAL PARTS

COIL GROUP

# 9.0

### INCREASED SAFETY AND ENCAPSULATED ELECTRICAL PARTS "eb mb"



IECEX certified



ZONE 1/21

## 492210 - ELECTRICAL PARTS "BOOSTER" 50 mm

These coils can be mounted with every Parker ATEX solenoid valves corresponding to the specified Coil Group.

See column "Coil Group" within valve pages.

Application: Control of solenoid valves in dangerous areas where explosion-proof protection - Ex eb mb IIC T5/T6 is required.

Benefits: Rotatable 360° fibreglass-reinforced plastic housing. Solenoid coil, fuses and varistor protection are completely encapsulated into the coil housing by epoxy resin for shock and corrosion protection. Small size for ease of mounting in confined space. Simplifies conversion of existing equipment to hazardous area requirements.

Available only in 24 VDC (suffix code : C2)



Reference	492210	
Certificate	LCIE 02 ATEX 6023 X - IECEx LCI 06.0011 X	
Coil group	9.0	
Type of protection	Gas	II 2 G - Ex eb mb IIC T5 / T6
	Dust	II 2 D - Ex tb IIIC - T95°C / T80°C
Degree of protection	IP66 according to IEC/EN 60529 Standards	
Ambient temperature	-40°C to +75°C / +40°C The operating temperature of the valve/coil can be limited by that of the valve	
Insulation Class	H 180°C	
Electrical connection	Connection box with terminals and cable entry via gland M20 x 1.5 Possibility for additional earth via external screw	
Power consumption DC	1 to 1.8 W according to length of cable	
Attraction current	I min = 60 mA (I nominal = 75 mA)	
Voltage DC	U nominal = 24 VDC (C2), Umin = 21.6 VDC	
Resistance	23 Ω + (R = 270 Ω)	
Inductance	0 mH	
Capacitance	0 μF	
Response time	2 - 4 s	
Weight	500 g	

To Order a Coil choose Coil Ref + Voltage Code, example: 492210 for 24 VDC = 492210C2

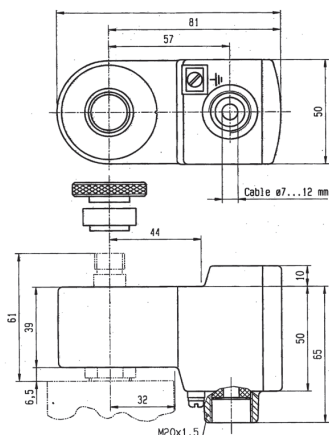

Indications:

Booster for Offshore valves

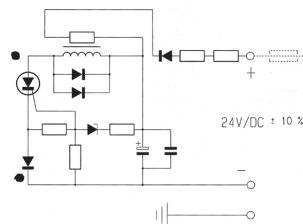

These electrical parts need an external fuse of I = 100 mA



**COIL GROUP**
**2.0/2.1**
**INCREASED SAFETY  
AND ENCAPSULATED  
ELECTRICAL PARTS "eb mb"**

IECEx certified



## 492190 - ELECTRICAL PARTS 50 mm

This coil can be mounted with every Parker ATEX solenoid valves corresponding to the specified Coil Group.

See column "Coil Group" within valve pages.

**Application:** Control of solenoid valves in dangerous areas where explosion-proof protection Ex eb mb IIC T3 to T4 is required.

**Benefits:** Rotatable 360°, fiberglass -reinforced plastic housing. Solenoid coil, rectifier (silicium diodes), fuses and varistor protection are completely encapsulated into the coil housing by epoxy resin for shock and corrosion protection.

Small size for ease of mounting in confined space.

**ZONE 1/21**

Reference	492190			
Certificate	LCIE 02 ATEX 6023 X - IECEx LCI 06.0011 X			
Coil Group	2.0 / 2.1			
Type of protection	Gas	II 2 G - Ex eb mb IIC T3 / T4		
	Dust	II 2 D - Ex tb IIIC - 195°C / 130°C		
Degree of protection	IP66 according to IEC/EN 60529 Standards			
Ambient temperature	-40°C to +75°C / +40°C The operating temperature of the valve/coil can be limited by that of the valve			
Insulation Class	H 180°C			
Electrical connection	Connection box with terminals and cable entry via gland M20 x 1.5 Possibility for additional earth via external screw			
Electrical consumption	DC	Pn (hot)	9 W	
		P (cold) 20°C	11 W	
	AC	Pn (holding)	11 W	
		Attraction cold	13 W	
Weight	320 g			
Voltages "Un" -10% to +10% of the Un	VAC/Hz	Code	VDC	Code
	24/50-60	P0	24	C2
	110/50-60	P2	48	C4
	230/50-60	P9	110	C5

To Order a Coil choose Coil Ref + Voltage Code, example: 492190 for 24 VDC = 492190C2

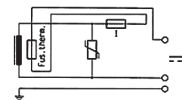
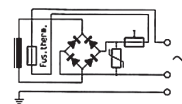
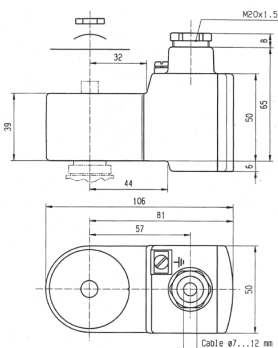

**EXPLOSION PROOF  
ELECTRICAL PARTS**

COIL GROUP

**7.0**

**INTRINSICALLY SAFE  
ELECTRICAL PARTS  
"ia"**



IECEx certified



**ZONE 0/20**

**483580 - 483960 ELECTRICAL PARTS 32 mm "IS"**

These coils can be mounted with every Parker ATEX solenoid valves corresponding to the specified Coil Group.

See column "Coil Group" within valve pages.

**Application:** Control of solenoid valves in dangerous areas where explosion-proof protection Ex ia IIC T6 is required.

**Benefits:** Fully encapsulated assembly comprising a coil, metal armature, three diodes circuit and DIN plug connection.

The encapsulation provides an effective compact housing offering full protection against dust, oil, water, etc.

Small size for ease of mounting in confined space. Available only in 28 VDC (suffix code : N7)



Reference (without plug) (with plug)	483580.01 483960.01	
Certificate	LCIE 02 ATEX 6065 X - IECEx LCI 07.0025 X	
Coil Group	7.0	
Type of protection	Gas II 1 G - Ex ia IIC - T6 Dust II 1 D - Ex ta IIIC - T80°C	
Degree of protection	IP65 with plug according to IEC/EN 60529 Standards	
Ambiant temperature	- 40°C à + 55°C The operating temperature of the valve/coil can be limited by that of the valve.	
Electrical connection	The coil is connected with a 2P + E plug according to EN 175301-803 type A Contact 1 is marked as the positive pole .	
Maximum supply voltage	28 VDC (N7) - 110 mA The minimum operating voltage at maximum 60°C is 14 VDC.	
Power	DC Minimum	500 mW
	Maximum	3 W
		Depending on applied voltage, IS barrier type and resistance of connected cable
Coil resistance at 20°C	340 Ω	
Impedance	340 Ω	
Apparent inductance	0 mH	
Apparent capacitance	0 μF	
Weight	160 g (with plug)	

To Order a Coil choose Coil Ref + Voltage Code, example: 483580 for 28 VDC = 483580N7

**Important**

The intrinsically safe supply circuit should have enough capacity in all environmental conditions to assure a minimum operating current of 35 mA through the coil.

For Valves with operator «96» and «97», a minimum current of 65 mA is required.

The minimal holding current is 20 mA.

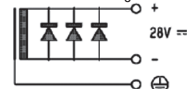

For the barrier compatibility see the corresponding table in in appendix section.

These coil must be used with suitable housing : Ref. 2995

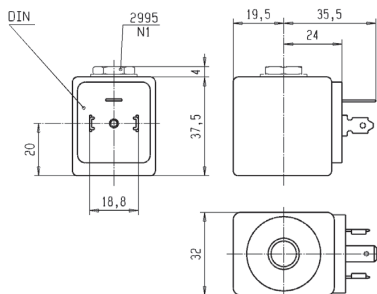

**COIL GROUP**
**8.0**
**INTRINSICALLY SAFE  
ELECTRICAL PARTS  
"ia"**

## 495910 - MINIWATT - 0.3 W ELECTRICAL PARTS "IS" "BOOSTER" 37 mm

These coils can be mounted with every Parker ATEX solenoid valves corresponding to the specified Coil Group.

See column "Coil Group" within valve pages.

Application: Control of solenoid valves in dangerous areas where explosion-proof protection Ex ia IIC T4 to T6 is required.

Benefits: Rotatable 360° fibreglass-reinforced plastic housing (class H). Solenoid coil, rectifier (silicium diodes), fuses and varistor protection are completely encapsulated into the coil housing by epoxy resin for shock and corrosion protection.

Small size for ease of mounting in confined space. Available only in 28 VDC (code: N7).

**ZONE 0/20**

Reference	495910		
Certificate	LCIE 03 ATEX 6464 X - IECEx LCI 07.0006 X		
Coil Group	8.0		
Type of protection	Gas	II 1 G - Ex ia IIC - T4 / T5 / T6	
	Dust	II 1 D - Ex ta IIIC T80 / 95 / 130°C	
Degree of protection	IP67 according to IEC/EN 60529 Standards		
Ambiant temperature	- 40°C to +80°C / 75°C / 65°C The application is limited also by the temperature range of the valve..		
Class of insulation	H 180°C		
Electrical connection	Electric connection is done in the connection box on an easily accessible connector terminals. The introduction of the cable (Ø min 7 mm, Ømax. 11 mm, section max. 2.5 mm²) in the connection box passes by the built in M20 x 1.5 cable gland		
Maximum supply voltage	28 VDC (N7) - 110 mA		
Power	DC	Minimum	0.3 W (with 13 VDC)
		Maximum	1.2 W (with 24 VDC)
	Depending on applied voltage, IS barrier type and resistance of connected cable		
Line check	4 mA or 5 VDC max		
Coil resistance at 20°C	Charge ~ 550 Ω - Holding ~ 500 Ω		
Impedance	0 mH		
Apparent inductance	0 µF		
Response time	2 - 3 s		
Weight	500 g		

To Order a Coil choose Coil Ref + Voltage Code, example: 495910 for 28 VDC = 495910N7

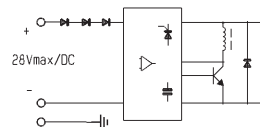
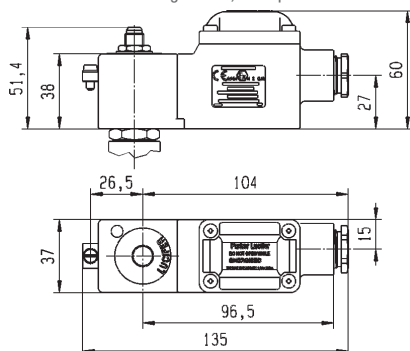

**EXPLOSION PROOF  
ELECTRICAL PARTS**

COIL GROUP

**9.0**

**INTRINSICALLY SAFE  
ELECTRICAL PARTS  
"ia"**



IECEx  
certified



**ZONE 0/20**

**496565 ELECTRICAL PARTS "BOOSTER"  
"IS" 37 mm**

This coil can be mounted with every Parker ATEX solenoid valves corresponding to the specified Coil Group.

See column "Coil Group" within valve pages.

**Application:** Control of solenoid valves in dangerous areas where explosion-proof protection Ex ia IIC T4 to T6 is required.

**Benefits:** Rotatable 360° fibreglass-reinforced plastic housing (class H). Solenoid coil, rectifier (silicium diodes), fuses and varistor protection are completely encapsulated into the coil housing by epoxy resin for shock and corrosion protection.

The plastic housing is delivered with M20 x 1.5 cable gland. Small size for ease of mounting in confined space. Available only in 28 VDC (code: N7).



Reference	496565	
Certificate	LCIE 08 ATEX 6071 X - IECEx LCI 08.0030 X	
Coil group	9.0	
Type of protection	Gas	II 1 G - Ex ia IIC - T4 / T5 / T6
	Dust	II 1 D - Ex ta IIIC - T80 / T95 / T130°C
Degree of protection	IP67 according to IEC/EN 60529 Standards	
Ambiant temperature	- 40°C to +80 / 75 / 65°C The application might also be limited by the temperature range of the valve.	
Electrical connection	Cable connection through a plastic cable gland M20 x 1.5 allowing use of cable diameter from 7 to 12 mm. Additional earth connection possible with external screw terminal.	
Class of insulation	H 180°C	
Minimum Courant of function	20 mA	
Minimum voltage of function at 60°C	28 VDC (N7)	
Safety parameters	28 V / 110 mA / 0.77 W	28 V / 280 mA / 1.96 W
Maximum acceptable values:	27 V / 120 mA / 0.81 W	27 V / 320 mA / 2.16 W
Ui (V) / Ii (mA) / Pi (W)	26 V / 135 mA / 0.88 W	26 V / 350 mA / 2.27 W
	25 V / 150 mA / 0.94 W	25 V / 390 mA / 2.43 W
	24 V / 170 mA / 1.02 W	24 V / 430 mA / 2.58 W
Line check	4 mA or 5 VDC max	
Apparent Impedance Typ.	Attraction ~ 600 Ω - Holding ~ 570 Ω	
Apparent Inductance	0 mH	
Apparent Capacitance	0 μF	
Response Time Typ.	2 - 4 s	
Weight	500 g	

To Order a Coil choose Coil Ref + Voltage Code,  
example: 496565 for 28 VDC = 496565N7

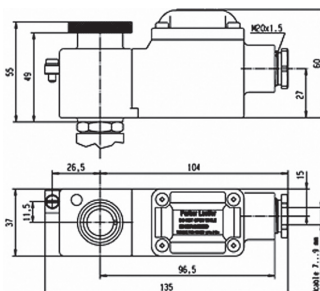

**COIL GROUP**
**9.0**
**INTRINSICALLY SAFE  
ELECTRICAL PARTS  
"ia"**

**492965 ELECTRICAL PART  
"BOOSTER" "IS" 50 mm**

This coil can be mounted with every Parker ATEX solenoid valves corresponding to the specified Coil Group.

See column "Coil Group" within valve pages.

**Application:** Control of solenoid valves in dangerous areas where explosion-proof protection Ex ia IIC - T6 is required.

**Benefits:** Rotatable 360° fibreglass-reinforced plastic housing. Solenoid coil, fuses and varistor protection are completely encapsulated into the coil housing by epoxy resin for shock and corrosion protection. Small size for ease of mounting in confined space. Simplifies conversion of existing equipment to hazardous area requirements.

Small size for ease of mounting in confined space. Available only in 28 VDC.

**ZONE 0/20**

Reference	492965.01 - (Stainless steel fixation) 492965.02 - (Plastic fixation)	
Certificate	LCIE 02 ATEX 6066 X - IECEx LCI 07.0007 X	
Coil Group	9.0	
Type of protection	Gas	II 1 G - Ex ia IIC - T6
	Dust	II 1 D - Ex ta IIIC - T80°C
Degree of protection	IP66 according to IEC/EN 60529 Standards	
Ambiant temperature	- 40°C to +65°C The application is limited also by the temperature range of the valve.	
Electrical connection	Cable connection through a plastic or stainless steel cable gland M20 x 1.5 allowing use of cable diameter from 10 to 12 mm. Additional earth connection possible with external screw terminal.	
Class of insulation	H 180°C	
Maximum supply voltage	28 VDC (N7) - 110 mA	
Power	DC	Minimum
		Maximum
		0.3 W (with 13 VDC) 2.3 W (with 24 VDC)
Line check	Depending on applied voltage, IS barrier type and resistance of connected cable 4 mA or 5 VDC max	
Coil resistance at 20°C	85 Ω	
Impedance	275 Ω (with 13 VDC) - 260 Ω (with 24 VDC)	
Apparent inductance	0 mH	
Apparent capacitance	0 μF	
Response time	2 - 4 s	
Weight	500 g	

To Order a Coil choose Coil Ref + Voltage Code, example: 492965.01 for 28 VDC = 492965.01N7

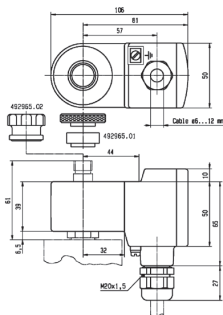
**Important**

The intrinsically safe supply circuit should have enough capacity in all environmental conditions to assure a minimum operating current of 29 mA through the coil.

The minimal holding current is 20 mA.

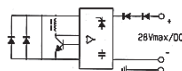

For the barrier compatibility see the corresponding table in appendix section.



## EXPLOSION PROOF ELECTRICAL PARTS

COIL GROUP

# 7.0

## INTRINSICALLY SAFE ELECTRICAL PARTS "ia"



ZONE 0/20

### 488650.01 & 490885 "NEMA" ELECTRICAL PARTS "IS" 50 mm

This coil can be mounted with every Parker ATEX solenoid valves corresponding to the specified Coil Group.

See column "Coil Group" within valve pages.

**Application:** Control of solenoid valves in dangerous areas where explosion-proof protection Ex ia IIC - T6 is required.

**Benefits:** Rotatable 360° housing, polyamid with fibreglass housing and cover. Coil, electronic circuits and other elements required for intrinsic safety are completely encapsulated in the housing with epoxy material for shock and corrosion protection.

Small size for ease of mounting in confined space.



Reference	488650.01		490885	
Certificate	LCIE 02 ATEX 6024 X		LCIE / FM / CSA	
Coil Group			7.0	
Type of protection	Gas	II 1 G - Ex ia IIC - T6	Cl. I, Div.I, Gr. A, B, C, D, Cl. II, Div.I, Gr. E, F, G	
	Dust	II 1 D - Ex ta IIC - T80°C		
Degree of protection	IP66 according to IEC/EN 60529 Standards		NEMA 4 - 4X	
Ambiant temperature	- 40°C to +65°C The operating temperature of the valve/coil can be limited by that of the valve.		60°C	
Electrical connection	Cable entry through a cable gland M20 x 1.5. Screw terminals for leads 3 x 1.5 mm² max. Additional earth connection possible with external screw terminal			
Class of insulation	H 180°C			
Maximum supply voltage	28 VDC (N7) - 110 mA The minimum operating voltage at maximum 60°C is 11.5 VDC.		30 VDC(L8) - 100 mA	
Power	DC	Minimum	300 mW	
		Maximum	3 W	
Dependent on the applied voltage, type of barrier IS and the resistance of the connected cable				
Coil resistance at 20°C			295 Ω	
Impedance			345 Ω	
Apparent inductance			0 mH	
Apparent capacitance			0 μF	
Weight			500 g	

To Order a Coil choose Coil Ref + Voltage Code, example: 490885 for 30VDC = 490885L8

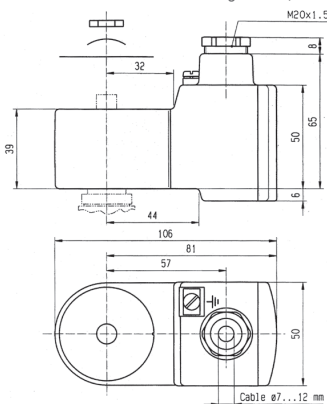

#### Important

The intrinsically safe supply circuit should have enough capacity in all environmental conditions to assure a minimum operating current of 29 mA through the coil.

The minimal holding current is 20 mA.

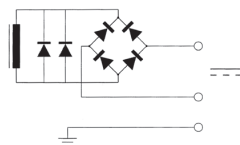

For the barrier compatibility see the corresponding table in appendix section.







## TABLE OF CONTENT

### INTRODUCTION

Index for Explosion Proof Electrical Parts ..... 414

List of Coil Groups ..... 415

### COILS

Coils for DIN plug connection ..... 418

Coils with flying leads ..... 432

Coils with screw terminal ..... 434

Coils with ISO-DIN connector ..... 441

### EXPLOSION PROOF ELECTRICAL PARTS

Level of protection "nAc nCc" ..... 445

Level of protection "db" ..... 452

Level of protection "mb" ..... 453

Level of protection "db mb" ..... 457

Level of protection "eb" ..... 462

Level of protection "eb mb" ..... 463

Level of protection "ia" ..... 466

**HOUSINGS** ..... 474

**COIL ACCESSORIES** ..... 478

**EXPLOSIVE ENVIRONMENTS** ..... 480

### COIL APPENDICES

Guidance chart for IS-Barriers ..... 490

## HOUSINGS

### HOUSING

# 4270

## COIL STANDARD HOUSING WITH SCREW TERMINALS

### Standard housing:

Reference:	4270
Material:	Epoxy varnished steel with cataphoresis traitement
Degree of protection:	IP according to IEC/EN 60529 IP 10 with armoured conduit IP 44 with cable gland
Electrical connection:	Can be made with armoured conduit or cable gland M12x1.5. Parts No. 495740 (cable gland M12x1.5) and 484093 to be ordered separately. Grounding connection by screw M3 on the inside of housing base plate.
Weight:	120 g



### Benefits:

This metal housing offers the ideal protection against shocks and corrosion - rotatable 360° - easy mounting in confined spaces - single-nut mounting - light weight - simplifies conversion of existing equipment to other requirements.

### Application:

The majority of our valves can be fitted with this standard housing, and can be mounted with several compatible coils group.

### Compatible coils:

- **481000 - Standard Coil**  
8 W Class F (155°C)
- **483520 - Double-Frequency Coil**  
9 W Class F (155°C)
- **481044 - Standard High-Power Coil**  
14 W Class F (155°C)
- **485100 - Standard High-Temperature Coil**  
8 W Class H (180°C)
- **486265 - High-Temperature and High-Power Coil**  
14 W Class H (180°C)

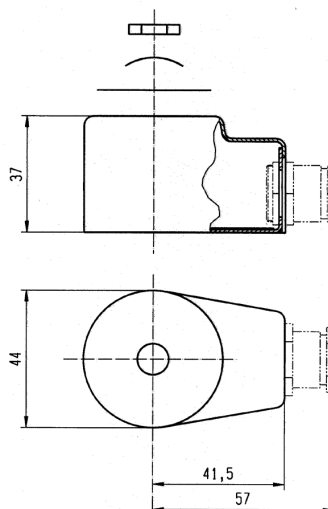

**HOUSING**
**4269**
**HOUSING FOR BISTABLE  
(IMPULSE) COILS**
**Housing for bistable coil:**

<b>Reference:</b>	<b>4269</b>
<b>Material:</b>	Epoxy varnished steel
<b>Degree of protection:</b>	IP according to IEC/EN 60529 IP 10 with armoured conduit IP 44 with cable gland
<b>Electrical connection:</b>	Can be made with armoured conduit or cable gland M12x1.5. Parts No. 484092 and 484093 to be ordered separately. Grounding connection by screw M3 on the inside of housing base plate.
<b>Weight:</b>	120 g

**Benefits:**

This metal housing offers the ideal protection against shocks and corrosion - rotatable 360° - easy mounting in confined spaces - single-nut mounting - light weight - simplifies conversion of existing equipment to other requirements.

**Application:**

This housing is specially designed for group 4.0 coils and can be mounted only with valves controlled by electrical impulses.

**Compatible coils:**

- **484990 - Impulse coil for AC**  
11 W Class F (155°C)
- **485400 - Impulse coil for DC**  
13 W Class F (155°C)

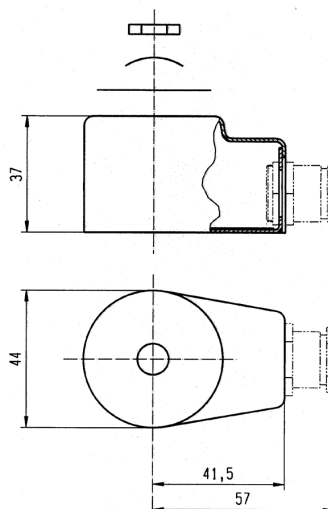

## HOUSINGS

### HOUSING

# 4538

## WATERPROOF AND DUSTPROOF HOUSING

### Waterproof housing:

<b>Reference:</b>	<b>4538</b>
<b>Material:</b>	Epoxy varnished steel
<b>Degree of protection:</b>	IP according to IEC/EN 60529 IP 67 with cable gland
<b>Electrical connection:</b>	Cable connection by cable gland M20x1.5 according to DIN 46320. Cable with outer diameter 6.5 - 13.5 mm can be simply sealed using a rubber gland with resilient sealing rings.  The enclosure is internally and externally fitted with grounding and earthing screw terminals.
<b>Weight:</b>	180 g



### Benefits:

This enclosure is dust- and waterproof. It corresponds to the degree of "International Protection" IP 67 according to IEC / EN 60529. Corrosion resistant, the metal housing offers good protection for the coil against shocks and other outside influences - rotatable 360° - easy mounting in confined spaces - easy access to the screw terminals - single-nut mounting - light weight - simple conversion of existing electrical equipment to other requirements without interruption of fluid passage in the valve.

### Application:

This housing can be equipped with several coils of our range, like the standard, double-frequency and magnetic latch coils.

### Compatible coils:

- **481000 - Standard Coil**  
8 W Class F (155°C)
- **483520 - Double-Frequency Coil**  
9 W Class F (155°C)
- **484990 - Impulse Coil for AC**  
11 W Class F (155°C)
- **485400 - Impulse Coil for DC**  
13 W Class H (180°C)

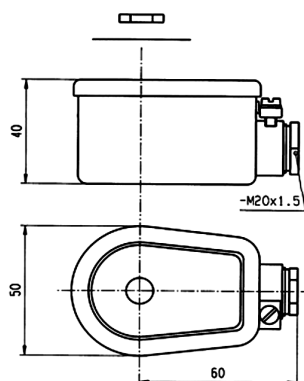

**HOUSING**
**8520**
**WATERPROOF HOUSING  
FOR HIGH-TEMPERATURE COILS**
**Waterproof housing:**

<b>Reference:</b>	<b>8520</b>
<b>Material:</b>	Epoxy varnished steel
<b>Degree of protection:</b>	IP according to IEC/EN 60529 IP 67 with cable gland
<b>Electrical connection:</b>	Cable connection by cable gland M20x1.5 according to European standards. Cable with outer diameter 6.5 - 13.5 mm can be simply sealed using a rubber gland with resilient sealing rings. The enclosure is internally and externally fitted with grounding and earthing screw terminals.
<b>Weight:</b>	180 g

**Benefits:**

This enclosure is dust- and waterproof. It corresponds to the degree of "International Protection" IP 67 according to IEC / EN 60529. Corrosion resistant, the metal housing offers good protection for the coil against shocks and other outside influences - rotatable 360° - easy mounting in confined spaces - easy access to the screw terminals - single-nut mounting - light weight - simple conversion of existing electrical equipment to other requirements without interruption of fluid passage in the valve.

**Application:**

The majority of our valves can be fitted with this housing and can be mounted with several compatible coils for high temperature (14 W, 8 W Class F or H).

**Compatible coils:**

- **481044 - Standard High-Power Coil**  
14 W Class F (155°C)
- **486265 - High-Temperature and High-Power Coil**  
14 W Class H (180°C)
- **485100 - Standard High-Temperature Coil**  
8 W Class H (180°C)

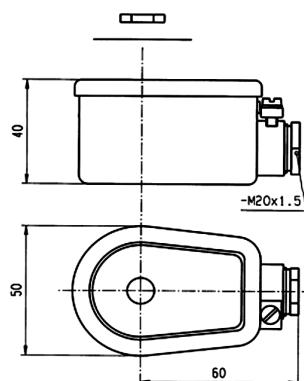

**COIL ACCESSORIES**

**22 mm**  
**32 mm**

**COIL ASSEMBLY KITS**

**COIL ASSEMBLY KIT FOR 22 mm COIL**

The coil assembly kit corresponds to the "housing" of Parker valve numbering system (Valve - housing - coil/voltage).

It is composed of a nameplate with the details of the valve type, a washer and a nut to secure the 22 mm coil to the valve.

**Caution:** This coil assembly kits for 22 mm coils are not adapted for our "Namur High Flow Range".

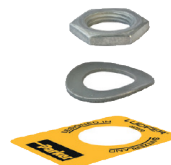

Reference	Specification	Application
8993	Standard - aluminium nameplate - passivated washer and nut - pressure indication in [bar]	Standard valves

**COIL ASSEMBLY KIT FOR 32 mm COIL**

The coil assembly kit corresponds to the "housing" of Parker valve numbering system (Valve - housing - coil/voltage).

It is composed of a nameplate giving details of the valve type, a round washer and a nut to ensure the fixing between 32 mm coil and the valve.



Reference	Specification	Application
2995	Standard - Aluminium nameplate - Passivated iron washer and nut - Pressure indication in [bar]	Standards valves



## ACCESSORIES

### DIN PLUG CONNECTOR ACCORDING TO EN 175301-803 - B

Part Number 48104340 (kit)

Electrical connection suitable for all 22 mm coils  
(e.g. 488980, 481180)



### DIN PLUG CONNECTOR ACCORDING TO EN 175301-803 - A

Part Number 48658640 (kit) or  
Part Number 49264540 (kit) for high temperature Parker version

Electrical connection suitable for all 32 mm coils  
(e.g. 481865, 492425)



### PLASTIC NUT WITH METAL INSERT

For Oil & Gaz electrical parts  
(e.g. 492965.01)



### CABLE GLAND

No. 492398 - Pg 13.5 - Ex eb II  
No. 493841 - M20x1.5 - Ex ia IIC

Electrical connection and mooring cable with 6 to 12 mm diameter, for electrical parts approved "eb mb" or "ia"  
(e.g. 492190, 492965....)



### CABLE GLAND

No. 493426 - 1/2"-14 NPT

Electrical connection and mooring cable with 6 to 12 mm diameter, for flameproof approved electrical parts  
(e.g. 493640)





# EXPLOSIVE ENVIRONMENTS

## INTRODUCTION

The current European Directive concerning equipment to be installed in potentially explosive atmospheres is **2014/34/EU**. It came into force on April 19th, **2016**. With respect to the previous version, it implies the switching from EC to EU Declarations of Conformity and Type Examination Certificates; moreover, it better defines the manufacturer's, importer's and distributor's responsibilities.

Electrical and mechanical equipment for use in potentially explosive atmospheres is certified by a notified body in accordance to the relevant European technical standards concerning each protection mode ( m, d, e, i, n, t, h ), EN 60079-0 etc. After certification project completion, and EU Type Examination Certificate is released, entitling it to carry the distinctive marking.

## EUROPEAN MEMBER COUNTRIES





## DEFINITIONS

### EXPLOSIVE ENVIRONMENTS

Mixture with air, under atmospheric conditions, of flammable substances in the form of gases, vapours, mists or dusts in which, after combustion has occurred, combustion spreads to the entire unburned mixture.

### HAZARDOUS AREAS

A hazardous area is an area in which an explosive gas environment is present, or may be expected to be present, in quantities such as to require special precautions for construction, installation and use of electrical apparatus.

### INGREDIENTS FOR AN EXPLOSION

- When combustible materials are mixed with air, an explosive mixture is produced. Danger of explosion therefore exists wherever these hazardous materials are handled: such a condition is to be found on the biggest chemical plant as well as at the smallest filling station.
- Nowadays with the use of electronic and electrical instrumentation in process control, the risk of combustion by electrical energy has increased sharply.
- To protect personnel and expensive equipment special precautions should be taken to prevent combustion of those dangerous substances. Conditions likely to ignite explosive mixtures are as follows:

Three conditions are enough to create an explosion.

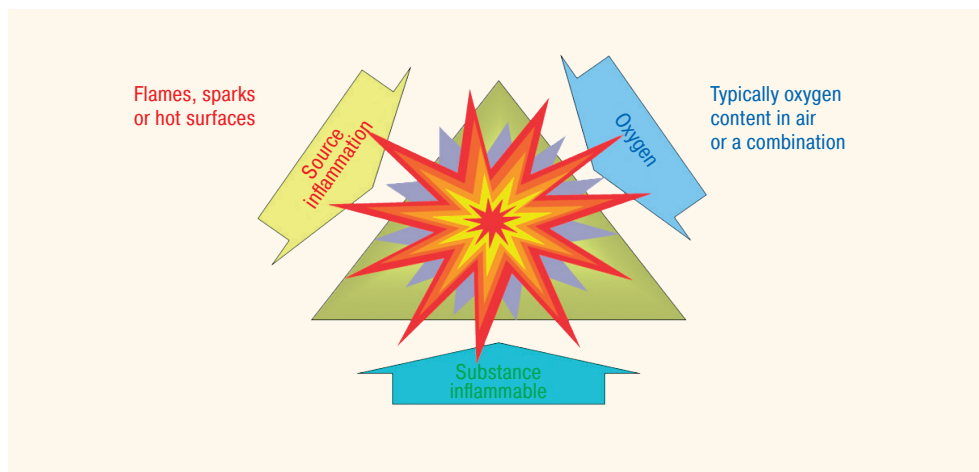



# EXPLOSIVE ENVIRONMENTS

## DEFINITIONS

### ZONES

The hazardous areas are classified in zones based on the frequency of the occurrence and the duration of an explosive gas environment as follows:

Zone 0 (20)	Zone 1 (21)	Zone 2 (22)
An area in which an explosive gas (dust) atmosphere is present CONTINUOUSLY or is present for LONG PERIODS (~1000 h/y).	An area in which an explosive gas (dust) atmosphere is present LIKELY TO OCCUR in normal operation (~10 to 999 h/y).	An area in which an explosive gas (dust) atmosphere is not LIKELY TO OCCUR and if it does occur it will exist for short period only (~1 to 10 h/y).
Mode of protection: ia - ta ...	Mode of protection: db - mb - eb - tb...	Mode of protection: ec - tc...

### HAZARDOUS LOCATION CLASSIFICATION

Explosive Environment	Continuous Presence	Intermittent Presence (normal operation conditions)	Occasional Presence (abnormal operation)
IEC	Zone 0 (gas) Zone 20 (dust)	Zone 1 (gas) Zone 21 (dust)	Zone 2 (gas) Zone 22 (dust)
Europe	Zone 0 (gas) Zone 20 (dust)	Zone 1 (gas) Zone 21 (dust)	Zone 2 (gas) Zone 22 (dust)
Canada (CEC) <sup>1</sup> USA (NEC) <sup>2</sup>	Cl. I Div. 1 (gas) Cl. II Div. 1 (dust) Cl.III Div. 1 (fibres)	Cl. I Div. 1 (gas) Cl. II Div. 1 (dust) Cl.III Div. 1 (fibres)	Cl. I Div. 2 (gas) Cl. II Div. 2 (dust) Cl.III Div. 2 (fibres)

<sup>1</sup> (CEC): Code Canadien d'Electricité / <sup>2</sup> (NEC): National Electrical Code

Example:

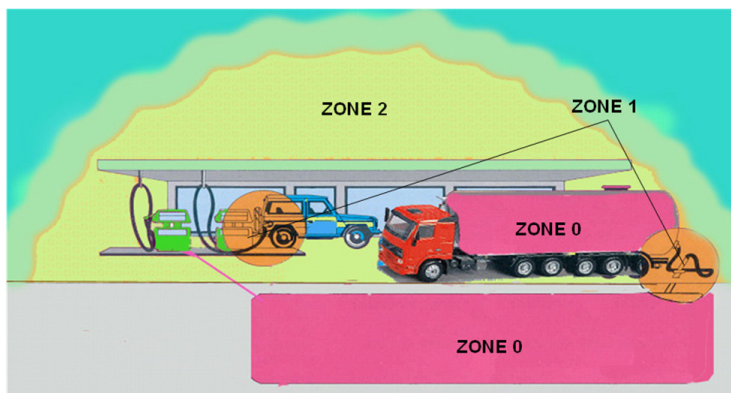



## DEFINITIONS

### HAZARDOUS LOCATION CLASSIFICATION

Category	Fault protection	Atmosphere	Zone	Example of protections
----------	------------------	------------	------	------------------------

#### EC Type examination by Notified Body annex III

<b>1</b> Very high level	2 types of protection or 2 independent faults	<b>G</b> (Gas)	<b>0</b>	"ia", "ta"...
		<b>D</b> (Dust)	<b>20</b>	

#### EC Type examination by Notified Body annex III

<b>2</b> High level	One type of protection Habitual frequent malfunction	<b>G</b> (Gas)	<b>1</b>	One type of protection "db", "mb", "tb"...
		<b>D</b> (Dust)	<b>21</b>	

#### Internal production inspection EC declaration of conformity

<b>3</b> Normal	Required level of protection	<b>G</b> (Gas)	<b>2</b>	"ec", "tc"...
		<b>D</b> (Dust)	<b>22</b>	

#### Hazardous Location Classification

Group	Gas Reference
I	Methane
IIA	Propane
IIB	Ethylene
IIC	Hydrogen / Acetylene

#### Hazardous Location Classification

Group	Dust Reference
-	-
IIA	Fibres
IIB	Non-conductive dust
IIC	Conductive dust

#### Surface Temperature Classes

Class Temperature	Max. Temperature	°C	Gas & Ignition Temperature
T1	450°C	600	560°C Hydrogen T1
T2	300°C	500	537°C Methane T1
T3	200°C	400	425°C Ethylene T2
T4	135°C	300	305°C Acetylene T2
T5	100°C	200	210°C Kerozene T3
T6	85°C	100	160°C Ethylether T4
		0	95°C Carbon disulphide T6





## EXPLOSIVE ENVIRONMENTS

### PROTECTION MODES IN PARKER FCSE PRODUCTS

Concept	Code		Zones	
	Gas	Dust	Gas	Dust
Flameproof enclosure	db	tb	1/2	21/22
Encapsulation	mb	tb	0/1/2	20/21/22
Increased Safety	eb	tb	1/2	21/22
Intrinsic Safety	ia	ta	0/1/2	20/21/22
Concept Cat.3 apparatus	nc	tc	2	22
Mechanical Part	h	h	0/1/2	20/21/22

In red, protection modes used by Parker FCSE.



## STANDARDS AND PROTECTION MODES

### ELECTRICAL EQUIPMENT FOR EXPLOSIVE GAS ATMOSPHERE EQUIPMENT GROUP II

EPL	Standards EN / IEC	Protection	Title
	60079-0	-	General requirements
Ga	60079-11	ia	Intrinsic safety
	-	-	-
	-	-	-
Gb	60079-1	db	Flameproof enclosures
	60079-7	eb	Increased safety
	60079-18	mb	Encapsulation
Gc	60079-7	ec	Increased safety
	60079-15	nc	Non sparking (C) or protected sparking ( A )
	-	-	-

EPL = Equipment Protection Level  
In red, protection modes used by Parker FCSE.



# EXPLOSIVE ENVIRONMENTS

## STANDARDS AND PROTECTION MODES



### ELECTRICAL EQUIPMENT FOR EXPLOSIVE DUST ATMOSPHERE - EQUIPMENT GROUP III

EPL	Standards EN / IEC	Protection	Title
	60079-0	-	General requirements
Da	60079-31	ta	Protection by enclosure
	60079-11	ia	Intrinsic safety
	-	-	-
Db	60079-31	tb	Protection by enclosure
	60079-18	mb	Protection by encapsulation
	-	-	-
Dc	60079-31	tc	Protection by enclosure
	-	-	-
	-	-	-

EPL = Equipment Protection Level  
In red, protection modes used by Parker FCSE.

### NON ELECTRICAL EQUIPMENT FOR USE IN POTENTIALLY EXPLOSIVE ATMOSPHERE

Standards	Protection	Title
ISO / EN ISO 80079-36	h	Basic method and requirement
ISO / EN ISO 80079-37	c, b, k	Constructional safety, control of ignition sources, liquid immersion

### ZONES AND EQUIPEMENT PROTECTION LEVEL (EPL)

Gas			Dust		
Zone	EPL		Zone	EPL	
0	Ga		20	Da	
1	Ga and Gb		21	Da and Db	
2	Ga, Gb and Gc		22	Da, Db and Dc	

### CATEGORIES AND EQUIPEMENT PROTECTION LEVEL (EPL)

Categories	Gas	Dust	Safety
1	Ga	Da	Very high
2	Gb	Db	High
3	Gc	Dc	Normal





## EXAMPLES OF MARKING

### ELECTRICAL APPARATUS FOR EXPLOSIVE GAS ATMOSPHERES EQUIPMENT GROUP II

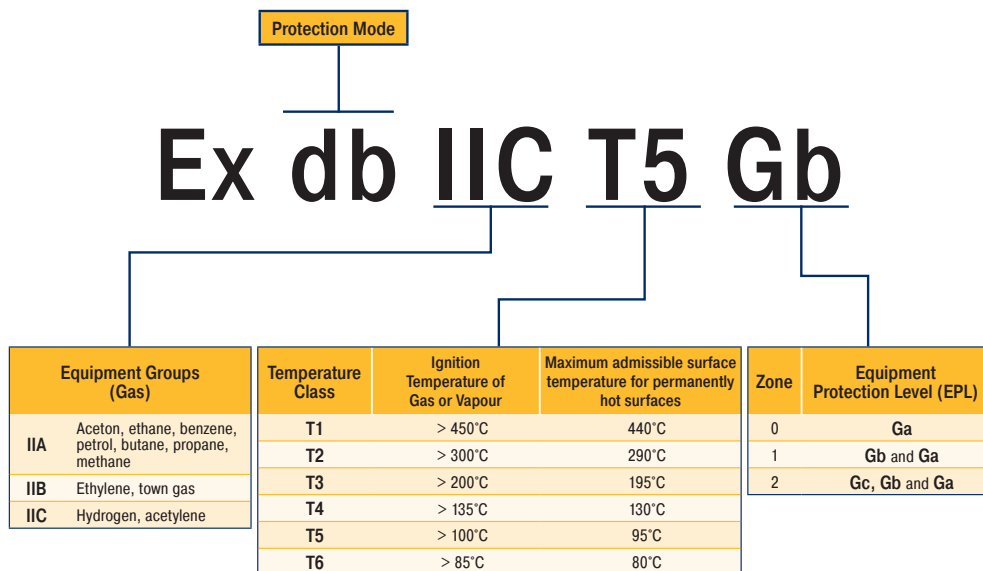

### ELECTRICAL EQUIPMENT FOR USE IN AREAS WITH COMBUSTIBLE DUST - EQUIPMENT GROUP III

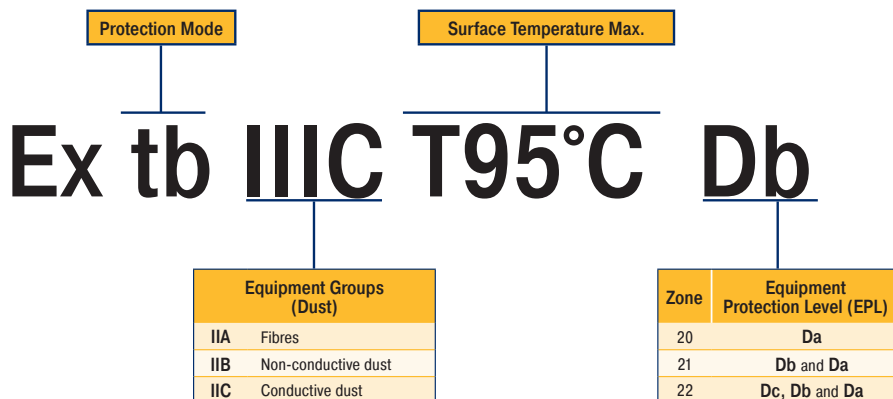



## EXPLOSIVE ENVIRONMENTS WHAT ABOUT THE DIRECTIVE ? (2014/34/EU - 19.04.16)

### ATEX 100 A DIRECTIVE - NEW APPROACH

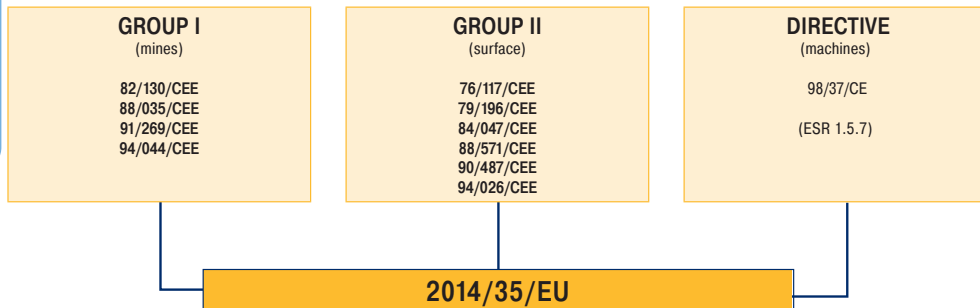

## THE FRAMEWORK OF THE DIRECTIVE

The main principles of the new directive can be summarized as follows:

- It applies to **electric** and **non-electric** equipment.
- It defines **essential health and safety requirements**.
- It takes into consideration all **potential hazards** equipment may cause, in particular at design and production level.
- **The one directive** applies to both **mines** susceptible to fire damp and **surface industries**.
- It stresses the importance of equipment being **used in accordance with its intended purpose**.
- It recognises The European Standards Committee **CEN** and the European Committee for Electrotechnical Standardisation **CENELEC** as competent bodies to fix the required harmonised standards.
- It provides for the **contribution of labour and management**.
- It defines **procedures for assessing conformity** to essential requirements, on the basis of modules which qualify equipment to carry the **CE** mark of conformity.

## APPLICATIONS

The directive applies to the industrial field and concerns the following equipment:

- **Equipment** (machines, apparatus, etc.)
- **Protective systems** (discharge devices, explosion suppression devices, etc.)
- **Components** (parts with no autonomous function, terminals, etc.)
- **Safety devices, controlling devices and regulating devices** intended for use outside potentially explosive environments but required for safety with respect to explosions (relays, barriers, pressure switches, thermostats, etc.)





## WHAT ABOUT THE DIRECTIVE ? (2014/34/EU - 19.04.16)

### EXCLUDED FROM THE SCOPE OF THE NEW DIRECTIVE

The following equipment falls outside the scope of the new directive:

- Medical devices intended for use in a medical environment.
- Equipment and protective systems relating only to the risk of explosion of unstable chemical substances (explosives, etc.)
- Equipment intended for use in domestic and non-commercial environments.
- Personal protective equipment covered by directive 89/686/EC.
- Seagoing vessels and mobile offshore units.
- Means of transport, except for vehicles intended for use in a potentially explosive environment.

### POTENTIAL IGNITION SOURCES AND OTHER HAZARDS TO BE CONTROLLED

The following all represent potential hazards:

- Various sources of ignition, such as sparks, flames, electric arcs, high surface temperature, acoustic energy, optical radiation or electromagnetic waves.
- Static electricity.
- Pressure compensation operations.
- Disturbance from external sources, such as changing environmental conditions, extraneous voltage, humidity, vibration or contamination.

Provision is also made for specific requirements governing devices used to provide additional equipment safety.

These requirements necessitate detailed analysis to assess the operational reliability of such devices and their interaction with other components connected with the equipment.

# COIL APPENDICES



## GUIDANCE CHART FOR IS-BARRIERS

Manufacturer	Reference	Ex	IS Standard Electrical Parts							IS Booster Electrical Parts			
			Ex ia IIC T6 488650.01/02 LCIE/AUS	Ex ia IIC T6 490885 (490895) LCIE/FM/CSA	Ex ia IIC T6 483580.01/03 483960.01/03 LCIE/AUS	Ex ia 490880 (493997) LCIE/FM/CSA	Ex ia IIB T6 482160.01 LCIE	Ex ia IIC T6 482870.01 LCIE	Ex ia LCIE/FM/CSA	Ex ia IIC T6 492965.01/02 LCIE	Ex ia IIC T6 496565 LCIE	Ex ia IIC T6 495910 LCIE	
A puissance 3	NAEV 22-140	ia	●	-	●	-	●	●	-	●	●	●	
	NAEV 26-100	ia	●	-	●	-	●	●	-	●	●	●	
ABB	V17132-54	ib	●	-	●	-	●	●	-	●	●	●	
	V17132-55	ib	●	-	●	-	●	●	-	●	●	●	
	V17132-61	ia	●	-	●	-	●	●	-	●	●	●	
	DO 890	ib	●	-	●	-	●	●	-	●	●	●	
	S900-DO4-EX	ib	●	-	●	-	●	●	-	●	●	●	
	BRADLEY	FEX-EX 24V	ia	●	●	●	●	●	-	●	●	●	
COOPER	LB 2101	ia	●	●	●	●	●	●	●	●	●	●	
	LB 2105	ia	●	●	●	●	●	●	●	●	●	●	
	LB 2112	ia	●	●	●	●	●	●	●	●	●	●	
ELCON	1881 / 1882	ia	●	●	●	●	●	●	●	●	●	●	
	471 / 472	ia	●	●	●	●	●	●	●	●	●	●	
	2871/2872	ia	●	●	●	●	●	●	●	●	●	●	
	2874/2875/2876	ia	●	●	●	●	●	●	●	●	●	●	
GEORGIN	AVB 122	ia	●	-	●	-	●	●	-	●	●	●	
	AVB 125	ia	●	-	●	-	●	●	-	●	●	●	
	AVB 128	ia	●	-	●	-	●	●	-	●	●	●	
Hima	F3328A	ib	●	-	●	-	●	●	-	●	●	●	
	F3335	ib	●	-	●	-	●	●	-	●	●	●	
	H4007	ib	●	-	●	-	●	●	-	●	●	●	
MTL	728P, 7128P, 7728P	ia	-	-	-	-	●	-	-	●	●	●	
	728, 7028, 7128, 7728	ia	●	●	●	●	●	●	●	●	●	●	
	3021, 4021, 4021S	ia	●	-	●	-	●	●	-	●	●	●	
	3022	ia	-	-	-	-	●	-	-	-	-	-	
	4023	ia	-	-	-	-	●	-	-	-	-	-	
	4024	ia	●	-	●	-	●	●	●	●	●	●	
	4025	ia	●	●	●	●	●	●	●	●	●	●	
	5021, 5023, 5024	ia	●	-	●	-	●	●	-	●	●	●	
	5025	ia	●	-	●	-	●	●	●	●	●	●	
	4521 / 4523 / 4524	ia	●	-	-	-	●	●	●	●	●	●	
	5521 / 5523 / 5524	ia	●	-	-	-	●	●	●	●	●	●	
	Pepperl & Fuchs	Z 728	ia	●	●	●	●	●	●	●	●	●	●
		Z 779	ia	●	●	●	●	●	●	●	●	●	●
EGA-041-3		ia	-	-	●	-	●	●	●	●	●	●	
KFD2-SD-EX1.36		ia	-	-	-	-	-	●	-	-	-	-	
KFD2-SL-EX1.36		ia	-	-	-	-	-	●	-	-	-	-	
KFD2-SD-EX1.48		ia	-	●	-	●	-	●	●	●	●	●	
KFD2-SL-EX1.48		ia	-	●	-	●	-	●	●	●	●	●	
KFD2-SL-EX1.48.90A		ia	-	-	-	-	-	-	-	●	●	●	
KFD2-SL-EX1.48.90A		ia	-	-	-	-	-	-	-	●	●	●	
KFD2-SL2-EX1.LK		ia	-	●	-	●	-	●	●	●	●	●	
KFD2-SL2-EX2		ia	-	●	-	●	-	●	●	●	●	●	
KSD2-BO-EX		ia	-	●	●	●	●	●	●	●	●	●	
RSD-BO-EX4		ib	-	●	-	●	-	●	●	●	●	●	
RSD-V0-EX8		ib	-	-	-	-	-	-	-	●	●	●	



## GUIDANCE CHART FOR IS-BARRIERS

Manufacturer	Reference	Ex	IS Standard Electrical Parts						IS Booster Electrical Parts			
			Ex ia IIC T6 488650.01/02 LCIE/AUS	Ex ia IIC T6 490885 (490895) LCIE/FM/CSA	Ex ia IIC T6 483580.01/03 483960.01/03 LCIE/AUS	Ex ia 490880 (493997) LCIE/FM/CSA	Ex ia IIB T6 482160.01 LCIE	Ex ia IIC T6 482870.01 LCIE	Ex ia LCIE/FM/CSA	Ex ia IIC T6 492965.01/02 LCIE	Ex ia IIC T6 496565 LCIE	Ex ia IIC T6 495910 LCIE
SIEMENS	5RD00-0AB0	ib	-	-	-	-	-	-	-	●	-	-
	7RD00-0AB0	ia	-	-	-	-	-	-	-	●	●	●
	7RD01-0AB0	ia	-	-	-	-	-	-	-	●	●	●
	7RD10-0AB0	ia	-	-	-	-	-	-	-	●	●	●
	7RD11-0AB0	ia	-	-	-	-	-	-	-	●	●	●
	7RD20-0AB0	ia	-	-	-	-	-	-	-	●	●	●
	7RD21-0AB0	ia	-	-	-	-	-	-	-	●	●	●
STAHL	9001/01-252-100-14	ia	●	●	27 V	27 V	●	●	●	●	●	●
	9001/01-280-100-10	ia	●	●	24 V	24 V	●	●	●	●	●	●
	9001/01-280-110-10	ia	●	-	24 V	-	●	●	-	●	●	●
	9002/13-280-100-04	ia	24 V	24 V	27 V	27 V	24 V	24 V	24 V	17 V	17 V	17 V
	9311/52-11-10	ia	-	●	●	25 V	25 V	●	●	15 V	15 V	15 V
	9111/63-11-00	ia	-	●	●	25 V	25 V	●	●	15 V	15 V	15 V
	9351/10-15-10	ia	-	●	●	-	-	●	●	●	●	●
	9351/10-16-10	ia	-	●	●	-	-	●	●	●	●	●
	9351/10-17-10	ia	-	-	-	-	-	●	-	-	-	-
	9381/10-187-050-10	ib	-	●	●	●	●	●	●	●	●	●
	9381/10-246-055-10	ib	-	●	●	●	●	●	●	●	●	●
	9381/10-246-070-10	ib	-	●	●	●	●	●	●	●	●	●
	9465/12-04-11	ib	-	●	●	-	-	●	●	●	●	●
	9475/12-04-21	ia/ib	-	●	-	●	-	●	●	●	●	●
	9475/12-04-31	ia/ib	-	-	-	-	-	-	-	●	●	●
	9475/12-08-41	ia/ib	-	-	-	-	-	-	-	-	-	-
	9475/12-08-51	ib	-	-	-	-	-	-	-	●	●	●
9475/12-08-61	ia/ib	-	-	-	-	-	-	-	-	●	●	
Turck	MK72-S01-EX	ib	-	-	-	-	●	●	-	●	●	●
	MK72-S02-EEX	ib	-	-	-	-	●	●	-	●	●	●
	MK72-S04-EEX	ib	●	-	●	-	●	●	-	●	●	●
	MK72-S05-EEX	ib	●	-	-	-	●	●	-	●	●	●
	MK72-S06-EEX	ib	●	-	●	-	●	●	-	●	●	●
	MK72-S07-EEX	ib	●	-	-	-	●	●	-	●	●	●
	MK72-S09-EEX	ia	-	-	-	-	-	-	-	-	-	-
	MK72-S12-EEX	ia	●	-	●	-	●	●	-	●	●	●
	MC72 - 41	ia	●	-	●	-	●	●	-	●	●	●
	MC72 - 43	ia	●	-	●	-	●	●	-	●	●	●
BARTEC	07-7331-2301/1000	ia	●	-	-	-	●	●	-	●	-	-
	07-7331-2301/1100	ia	●	-	●	-	●	●	-	●	-	-

If barrier reference not listed, consult factory for compatibility (FCCE.FCSE.Technical@support.parker.com)

# TECHNICAL INFORMATION ABOUT SOLENOID VALVES

## General Information

Solenoid valves are electro-mechanical devices used for interrupting or diverting the flow of fluids by opening or closing one or more orifices.

**The solenoid valve is a combination of three basic components:**

1. An electromagnet consisting of a solenoid (windings) and a magnetic yoke.
2. A pilot with a moveable plunger (which, in some cases directly opens and closes the valve).
3. A valve body with an orifice opened or closed by plunger or diaphragm to enable or prevent flow of the medium.

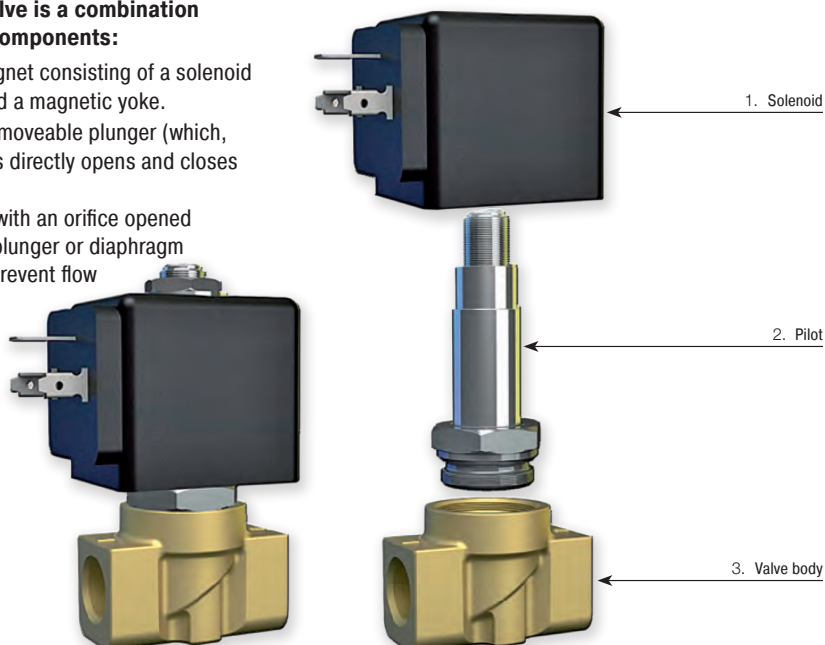

## Operating principles

The term solenoid refers to operator and coil, also known as pilot or magnetic actuator.

The coil consists of copper wire wound on a support reel. When electric current is applied into the coil, magnetic flow lines are generated which are stronger in the coil center.

This magnetic flow raises the moveable plunger in the coil until it brings it into contact with the pole piece. The valve body has an orifice through which the fluid flows when the valve is open.

The moveable plunger has an integral seat which when the solenoid coil is energised, moves off the valve (direct operated) orifice or diaphragm (pilot operated) orifice opening the valve.

When the coil is de-energised, a return spring brings the plunger back to the original closing position, thus cutting off the flow of the fluid.

## BASIC COMPONENTS OF A SOLENOID VALVE

<b>Valve body:</b>	Main part of the solenoid valve including ports, seat and orifices.
<b>Solenoid tube assembly:</b>	Cylinder, in stainless steel, hermetically sealed and closed at one extremity. It is the guide channel of the moveable plunger which is moved magnetically. The solenoid coil is fitted on the external side of the enclosing tube.
<b>Moveable plunger:</b>	Made by ferritic stainless steel, it is attracted by the solenoid magnetic field and slides inside the tube.
<b>Plunger spring (or return spring):</b>	Used to hold the moveable plunger in position and to return it when de-energized.
<b>Seat seal:</b>	Part of the moveable plunger, it is used to close a valves main orifice or pilot orifice.
<b>Electromagnet (or solenoid coil):</b>	Electrical part consisting of a copper windings (solenoid) along, with a magnetic yoke (armature), when electric current flows through, it generates a magnetic field attracting the moveable plunger.
<b>Housing:</b>	Part that contains and protects the coil.
<b>Yoke:</b>	Metalic case surrounding the coil and concentrating electro-magnetic force on the moveable plunger.

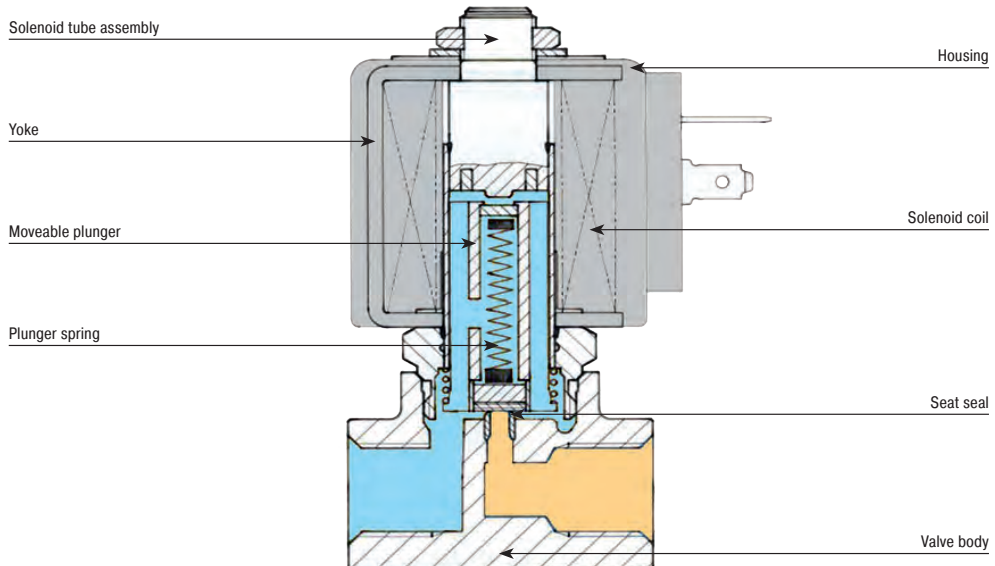

## TECHNICAL INFORMATION

# TECHNICAL VOCABULARY USED IN TABLES

Actuation	Body	Function	Port Size	Orifice (mm)	Flow Factor Kv(l/min)	MOPD (bar)	Max Fluid Temp. (°C)
-----------	------	----------	-----------	--------------	-----------------------	------------	----------------------

## NORMALLY CLOSED

Port size	Orifice Ø	Flow factors			Operating Pressure Differential			Fluid Temp.		Seat Seal	Parker Valves			Power		Coil Group	Dwg. No.
		Kv l/min	KV m³/h	Qn l/min	Min bar	Max(MOPD) AC bar	DC bar	Min °C	Max °C		Valve Ref.	Housing Ref.	Coil Ref.	AC W	DC W		

The basic technical features of each solenoid valve are indicated in the tables, the terminology used is shown and explained below. Please notice that in certain sections you will have the choice between two product ranges: Parker valves, within blue tables and the Parker valves, within orange tables.

<b>Actuation:</b>	The mechanical method used to control the flow.
<b>Body:</b>	Main part of the solenoid valve with the ports, seats and orifice needed.
<b>Function:</b>	The way the valve operates when de-energised.
<b>Port Size:</b>	Fitting dimensions are defined as threaded in inches (G), in BSP or Sub-base, when a flat interface for ports is adopted.
<b>Orifice (mm):</b>	Main orifice diameter in millimetres (nominal diameter).
<b>Flow Factors:</b>	Define the quantity of water which flows through the solenoid valve with a pressure drop of 1 bar during one minute. Expressed in l/min and m³/h.
<b>Max Fluid Temperature:</b>	Maximum fluid temperature the valve can withstand.
<b>Max Ambient Temperature:</b>	Maximum ambient temperature the valve can withstand typical value for pressure vessel is 50°C.
<b>Minimum Operating Pressure Differential:</b>	The lowest differential pressure required for operation (bar).
<b>Maximum Operating Pressure Differential (MOPD):</b>	The highest working differential pressure with 90% of the rated voltage (-10% Vn) applied to the solenoid coil (for AC) and 95% of the rated voltage (-5% Vn)(for DC).





## TECHNICAL INFORMATION

Solenoid valves are highly engineered products that can be used in many diverse applications.

In addition to operational functionality, media compatibility and suitability for the operating environment when selecting the best product for a given application.

This section provides a brief overview of the components, actuation and function modes of solenoid valves available from Parker Hannifin - FCSE.

### Different Technologies:

Solenoid valves are electrically operated devices used to control flow. The most common types of solenoid valve are:



**Magnalift Valves**



**Direct Operated  
Valves**

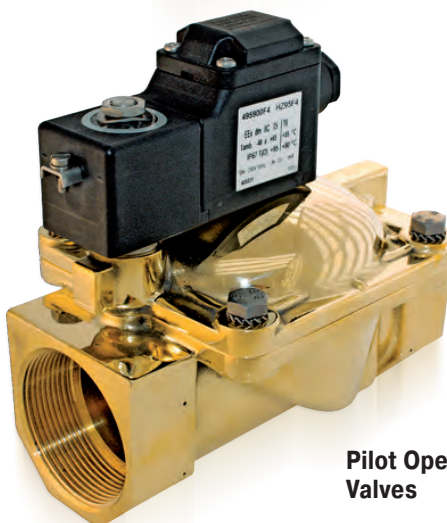

**Pilot Operated  
Valves**

# DIRECT OPERATED VALVE

Magnetic force is used directly to open or close the plunger which controls the passage of the fluid. Performances are limited by the coil, the pressure, and the valve orifice size. For direct operated valves, the minimum working pressure is 0 bar and the maximum pressure relies on the combination (valve/coil) chosen.

## Direct Operated Valve

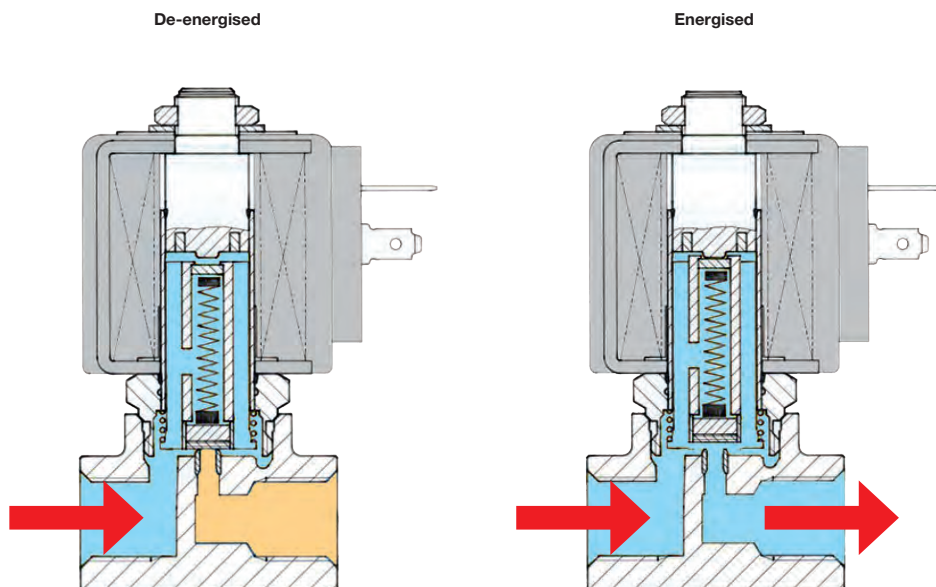

Example:  
• 121 Series

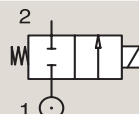

## PILOT OPERATED VALVE

To control a higher flow, it is necessary to use pilot operated valves. The supply pressure enters the direct operated "pilot stage" which directs the flow to a "pilot chamber" which, in turn, applies the pilot pressure over a large area (generally a diaphragm or piston). Therefore, a large force is generated to move the main sealing elements against higher pressure or over a large orifice.

One condition of operation is to have a minimum pressure available to shift the valve (indicated in the catalogue). In most applications, this presents no particular problems (refer to magnalift valve section). The pressure rating of the valve starts between 0.1 to 0.5 bar (depending on the valve). (NB. Pilot Operated Valves are also called Servo Operated Valves).

### Pilot Operated Valve

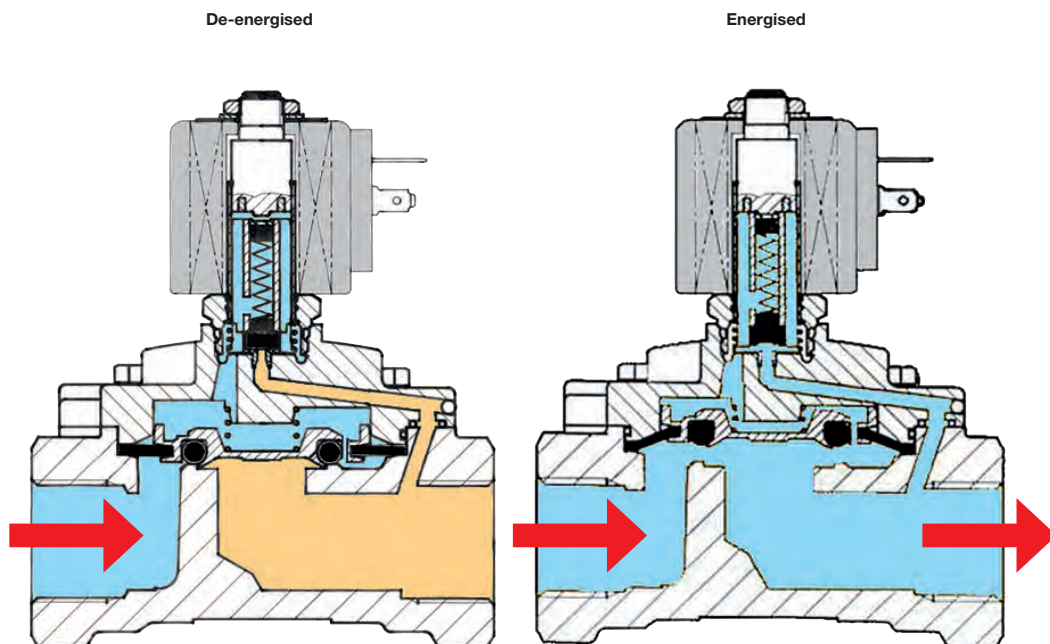

Example:

- 321 Series
- 7321B Series

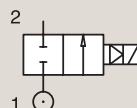

# MAGNALIFT VALVE

The magnalift valves combine the features of the direct operated and pilot operated valves. A mechanical link between the plunger and diaphragm retainer allows the valve to operate as a direct operated valve at low pressures and as a pilot operated valve at higher pressures. Magnalift valves are specially designed for applications where 0 pressure is needed to operate the valve, as well as bigger flow than a direct operated valve.

## Magnalift Operated Valve

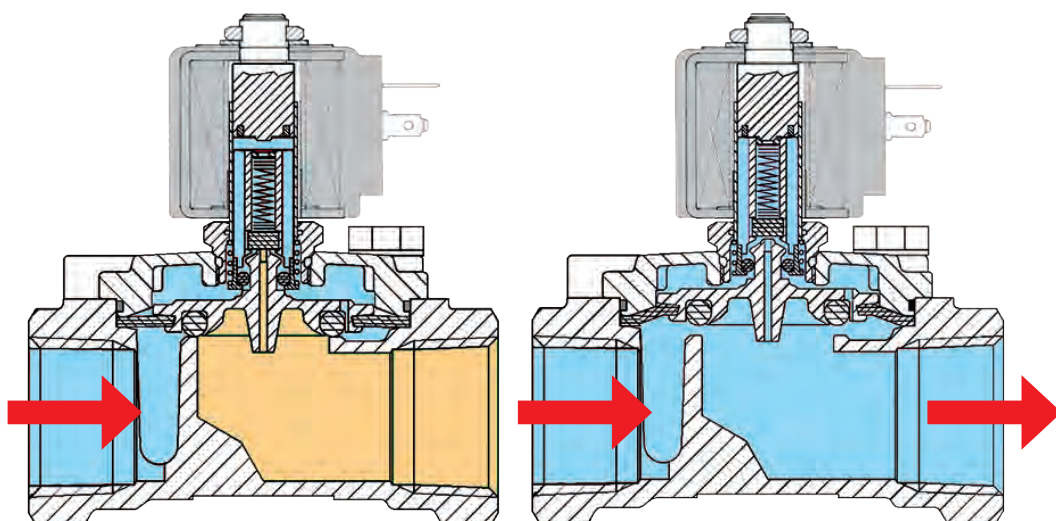
**De-energised**
**Energised**

**Example:**

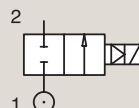
- 221 Series



## NORMALLY CLOSED VALVE

Most of our valves are available in normally closed and normally open configuration when not energized. In certain applications, you may require a normally open valve (open function in case of current failure). The differentiating factor of design of this technology, is based upon the design of the seat seal, which is reversed in comparison to a normally closed valve.

### Normally Closed Valve

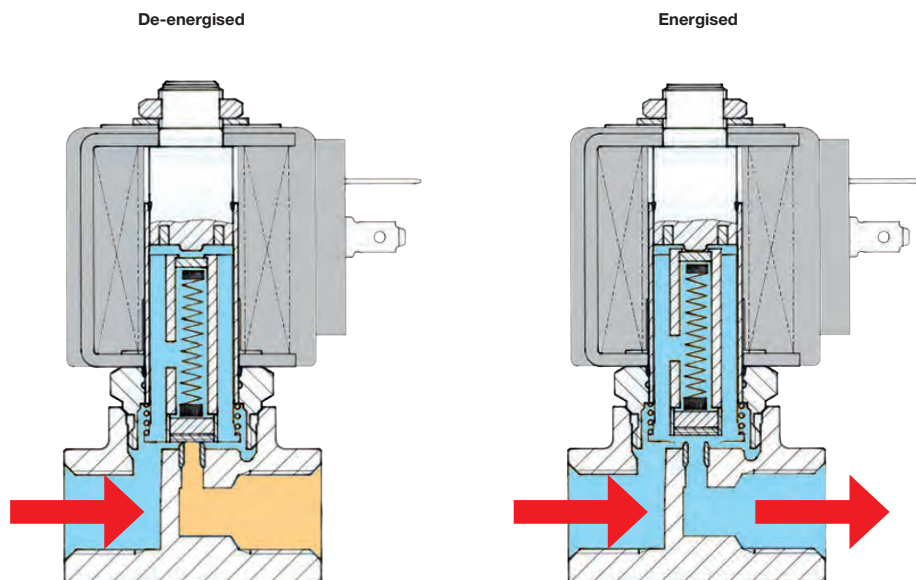

Example:  
• 121 Series

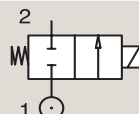

# NORMALLY OPEN VALVE

## Normally Open Valve

De-energised

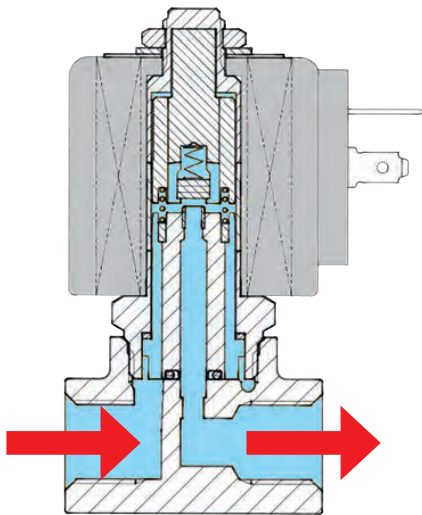

Energised

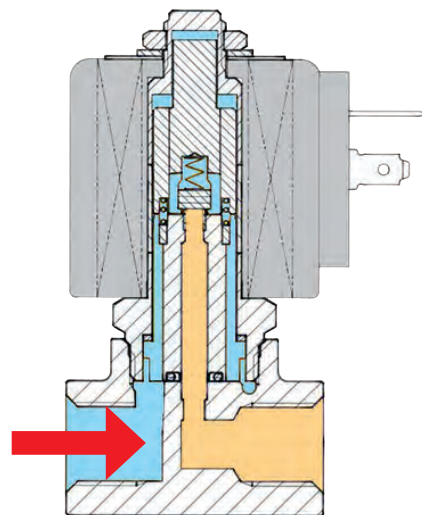

Example:  
• 122 Series

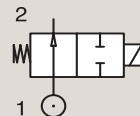

**TECHNICAL  
INFORMATION**

# FLOW AND PRESSURE RANGES

## Area of operation:

Each valve principle, as described in the previous pages, has a defined area of operation related to its pressure and flow capabilities. The following graph shows which type of valve is suitable for a certain situation.

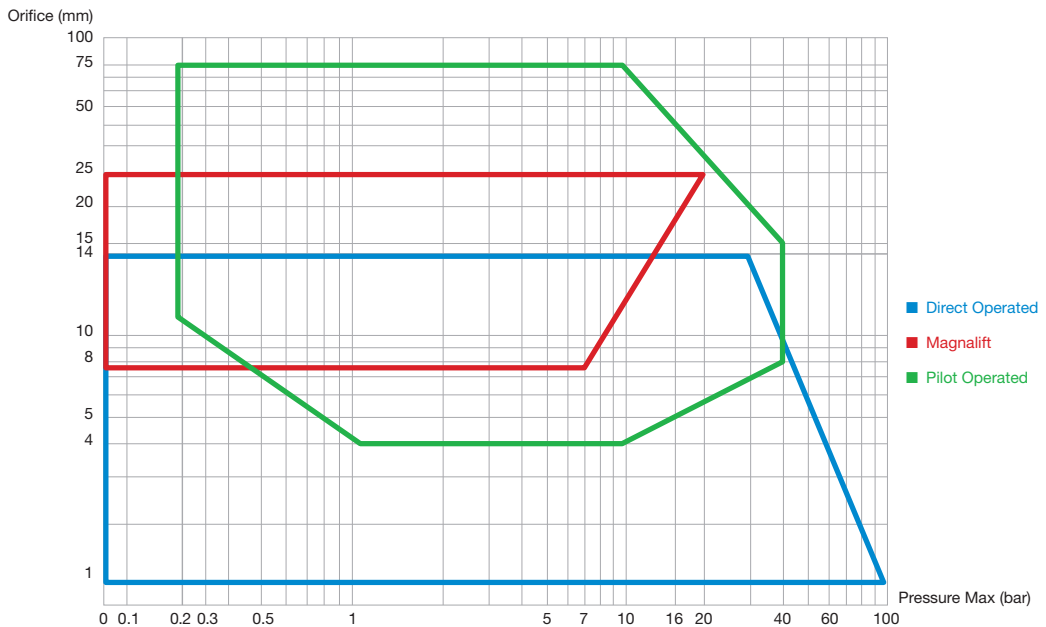

Areas of operation of Parker solenoid valves.



## SIZING SOLENOID VALVES

The correct choice of solenoid valve is essential as it determines the regulation and performance required for practical application on a system. In order to decide on the exact type of solenoid valve, various parameters have to be known.

However the calculation method, based on the flow coefficient  $K_v$ , has proved highly practical as it can be determined on the basis of:

- Required flow rate
- Type of fluid and relative viscosity
- Flow resistance
- Specific gravity and temperature

This flow coefficient  $K_v$  is determined as defined in the VDI/VDE 2173 standards.

It represents the flow of water in m<sup>3</sup>/h or L/min with a temperature from 5 to 30°C which passes through the solenoid valve with a pressure drop of 1 bar.

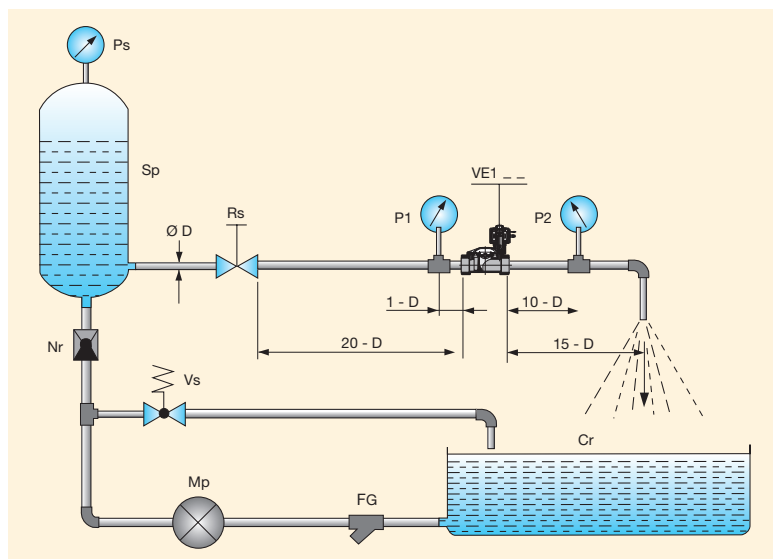

**Note:**

The flow coefficient used in the USA is known as  $C_v$  and represents the water flow rate in US gallons per minute with a pressure drop  $\Delta P$  of 1 psi.

To convert  $C_v$  in  $K_v$  and vice versa use:

$$1 K_v = 0.862 C_v$$

$$1 C_v = 1.16 K_v$$

FG = Grid Filter    Mp = Pump    Vs = Safety Valve    Nr = Check Valve    Sp = Pressure Tank    Ps = Static Pressure Manometer

After existing conditions have been converted into this factor  $K_v$ , the type of valve is found by referring to the pages in the related sections in this catalogue.

**Parameters used for selecting the solenoid valve are in the table next page.**

Consult conversion tables of the various units of measurement as defined by the ISO (International Standards Organisation) - I.S. (International System) set out in this catalogue.

## FLOW AND PRESSURE RANGES

### Pressure

symbol (P)  
unit of measurement [bar]  
Working pressure

### Pressure drop

symbol ( $\Delta P$ )  
unit of measurement [bar]  
Pressure difference between inlet ( $P_1$ ) and outlet ( $P_2$ ) of the solenoid valve when a medium is flowing through the valve ( $\Delta P = P_1 - P_2$ ).

### Flow coefficient

symbol ( $K_v$ )  
unit of measurement [l/min]

### Specific gravity of the medium

symbol ( $\gamma$ )  
unit of measurement [Kg/dm<sup>3</sup>]

### Temperature of the medium

symbol (t)  
unit of measurement [°C]

### Flow rate

- for liquids
  - symbol (Q)
  - unit of measurement [l/min]
- for gases
  - symbol ( $Q_n$ )
  - unit of measurement [Nm<sup>3</sup>/h]
- for steam
  - symbol ( $Q_v$ )
  - unit of measurement [Kg/h]

### Specific volume

symbol ( $V_s$ )  
unit of measurement [m<sup>3</sup>/Kg]

### a) Solenoid valves for liquids:

Flow rate:  $Q = K_v \cdot \sqrt{\frac{\Delta P}{\gamma}}$  where:  $Q = \text{l/min}$   
 $\Delta P = \text{bar}$   
 $\gamma = \text{Kg/dm}^3$

Flow coefficient:  
 $K_v = Q \cdot \sqrt{\frac{\gamma}{\Delta P}}$

In the case of liquids with viscosity greater than 3°E (22 cStokes) the  $K_v$  is modified according to the formula:

$$K_{v_1} = K_v + C \quad C = \frac{\delta \cdot \sqrt{K_v + 1}}{200 \cdot Q}$$

where C is the viscosity correction factor calculated by means of the formula:

where:

$\delta$  = kinematic viscosity of the fluid expressed in centistokes

$K_v$  = flow rate factor of the solenoid valve

Q = flow rate in l/min

Pressure drop:

$$\Delta P = \gamma \cdot \left(\frac{Q}{K_v}\right)^2$$

### b) Solenoid valves for gases:

If  $\Delta P \leq 1/2 P_1$  use the following formulae:

**Flow rate:**  $Q_n = 514 \cdot K_v \cdot \sqrt{\frac{\Delta P \cdot P_2}{\gamma_n \cdot (273 + t)}}$

where:  $Q_n = \text{Nm}^3/\text{h}$      $P_1 = \text{bar}$      $P_2 = \text{bar}$

**Flow coefficient:**  $K_v = \frac{Q_n}{514} \cdot \sqrt{\frac{(273+t) \cdot \gamma_n}{\Delta P \cdot P_2}}$

$t = ^\circ\text{C}$   
 $\gamma_n = \text{Kg}/\text{dm}^3$

**Pressure drop:**  $\Delta P = \frac{(273 + t) \cdot \gamma_n \cdot Q_n^2}{P_2 \cdot (514 \cdot K_v)^2}$

If  $\Delta P > 1/2 P_1$  use the following formula:

$Q_n = 757 \cdot K_v \cdot \sqrt{\frac{\Delta P \cdot P_2}{(273 + t) \cdot \gamma_n}}$

### c) Solenoid valves for steam:

If  $\Delta P \leq 1/2 P_1$  use the following formulae:

**Flow rate:**  $Q_v = 31,7 \cdot K_v \cdot \sqrt{\frac{\Delta P}{V_s}}$

where:  $Q_v = \text{Kg}/\text{h}$      $\Delta P = \text{bar}$      $V_s = \text{m}^3/\text{Kg}$

**Flow coefficient:**  $K_v = \frac{Q_v}{31,7} \cdot \sqrt{\frac{V_s}{\Delta P}}$

**Pressure drop:**  $\Delta P = V_s \cdot \frac{Q_v^2}{(31,7 \cdot K_v)^2}$

If  $\Delta P > 1/2 P_1$  use the following formula:

$Q_v = 22,4 \cdot K_v \cdot \sqrt{\frac{P_1}{V_s}}$

#### Notes:

#### 1) Should the value $\Delta P$ not be specified, use the following, which is based on experience:

- For liquids only in the case of free discharge  $\Delta P = 90\%$  of the input pressure ( $P_1$ ).
- For gases never use a  $\Delta P$  of more than 50% of the absolute inlet pressure, since the excessive pressure drop may cause an irregular flow rate. In most cases,  $\Delta P$  can be considered as 10% of the input pressure.

#### 2) Specific volume value ( $V_s$ ) for dry saturated steam, see the table in diagram 3.



## TECHNICAL INFORMATION

# FLOW RATE FOR LIQUIDS

The liquid flow through a pipe or a valve is given by:

$$Q = K_v \cdot \sqrt{\frac{\Delta P}{\gamma}}$$

- Where
- Q = Flow [l/min]
  - $\Delta P$  = Differential Pressure [bar]
  - $\gamma$  = Density of the fluid [kg/dm<sup>3</sup>]  
(water  $\gamma$  = 1 [kg/dm<sup>3</sup>])
  - $k_v$  = Flow Factor [l/min ]

### Flow factor $k_v$ :

The  $k_v$  flow factor of a valve is defined as the flow rate of water in litres per minute with a pressure drop of 1 bar across the valve. Valve manufacturers use different definitions for  $k_v$ . It may be expressed in l/h or m<sup>3</sup>/h. Care should therefore be taken when comparing values.

### Maximum flow rate $Q_{max}$ .

For particular 2-way valves the maximum flow must be limited for reasons of mechanical resistance and durability. A very high flow velocity may dislocate a popet sealing or a diaphragm. Maximum flow rates are indicated in the catalogue.

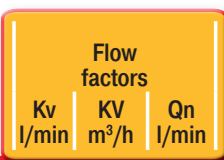

## NORMALLY CLOSED

Port size	Orifice $\varnothing$	Flow factors			Operating Pressure Differential			Fluid Temp.		Seat Seal	Parker Valves			Power		Coil Group	Dwg. No.
		$K_v$ l/min	$KV$ m <sup>3</sup> /h	$Q_n$ l/min	Min	Max(MOPD)	DC	Min	Max		Valve Ref.	Housing Ref.	Coil Ref.	AC	DC		
BSP	mm				bar	AC bar	DC bar	°C	°C					W	W		



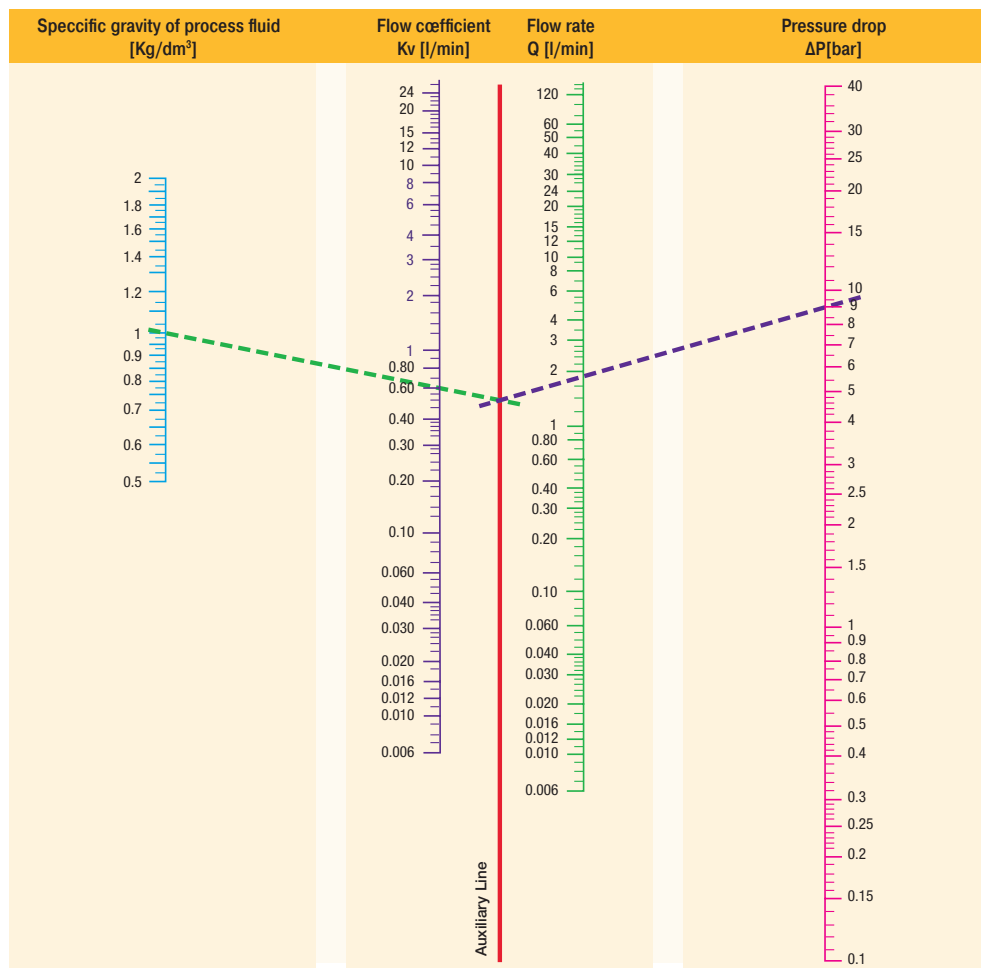

Monogram for liquid flow calculation

Specific gravity of the most common fluids ( $\rho = \text{Kg/dm}^3$ ) - ( $t = 15^\circ\text{C}$ - $P = 760 \text{ mm Hg}$ )			
Acetone	0.76	Benzenol	0.90
Water	1.00	Beer	1.02
Sea water	1.02	Hexane	0.66
Ethyl alcohol	0.79	Ethane	0.68
Methyl alcohol	0.81	Diesel oil	0.70
Petrol	0.68	Milk	1.03
		Naphtha	0.76
		Pentane	0.63
		Vegetable oil	0.92
		Hydraulic oil	0.92
		Wine	0.95

## FLOW RATE FOR GASES

The gas flow through a valve is given by:

$$Q = C \cdot P_1 \cdot k_T \cdot \omega \cdot \gamma_{\text{air}} / \gamma_{\text{gas}}$$

Where

- Q = Flow Rate [dm<sup>3</sup>/s]
- C = Conductance [dm<sup>3</sup>/s.bar]
- P<sub>1</sub> = Inlet Pressure [bar abs]
- γ = Specific Weight [Kg/dm<sup>3</sup>]
- k<sub>T</sub> = Temperature Correction Factor

$$\omega = \sqrt{1 - \frac{P_2/P_1 - b}{1 - b}}$$

$$k_T = \sqrt{\frac{293}{273 + \text{Temp. } ^\circ\text{C}}}$$

### Nominal Flow Q<sub>n</sub>:

Calculations can be made with specific flow factors based on the CETOP RP 50P standard. For practical purposes and ease of valve selection the catalogue shows the nominal flow Q<sub>n</sub>. The nominal flow Q<sub>n</sub> is defined as the flow rate (L/min) of air across the valve when the inlet pressure P<sub>1</sub> = 6 bar and the pressure drop ΔP = 1 bar.

N.B.

The values of the flow factors and flow rates mentioned in catalogues are subject to +/- 15% tolerances.

### Pneumatic application: $\gamma_{\text{air}} / \gamma_{\text{gas}} = 1$

- a) Choked flow conditions  $P_2 \leq b \cdot P_1$   
in this case  $\omega = 1 \rightarrow Q = C \cdot P_1 \cdot k_T$
- b) Free flow conditions  $P_2 > b \cdot P_1$   
in this case  $\rightarrow Q = C \cdot P_1 \cdot k_T \cdot \omega$

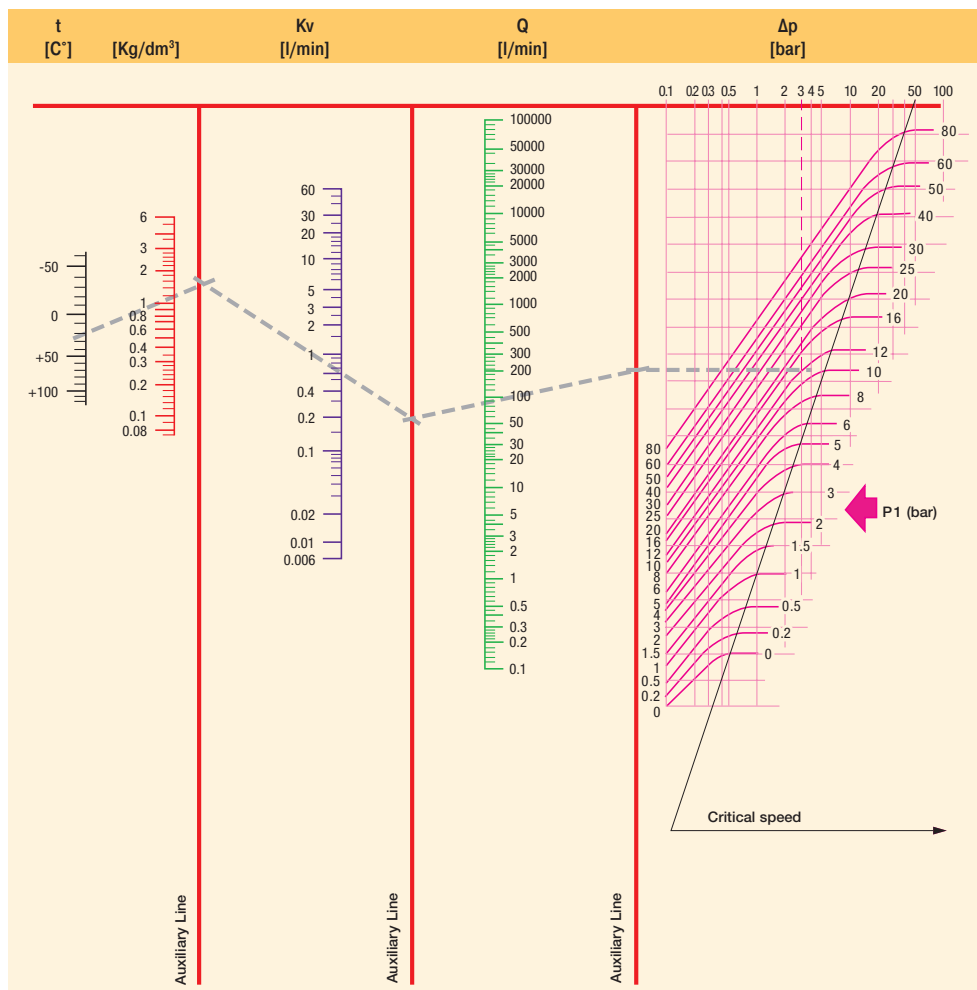

t = Fluid Temperature     $\gamma_N$  = Specific Gravity    Kv = Flow Coefficient    Qn = Flow Rate     $\Delta p$  = Pressure Drop    P<sub>1</sub> = Inlet Pressure

**Specific gravity of the most common gases ( = Kg/m<sup>3</sup> ) - ( t = 0°C - P = 760mm Hg)**

Acetylene	1.176	Helium	0.179	Natural gas	0.723
Carbon dioxide	1.965	Ethane	1.035	Methane	0.722
Air	1.293	Ethylene	1.259	Carbon monoxide	1.250
Argon	1.780	Hydrogen	0.089	Oxygen	1.429
Nitrogen	1.255			Propane	1.520
Butane	2.000			Steam	0.805

# TECHNICAL INFORMATION

## Diagram 3 for Dry Saturated Steam

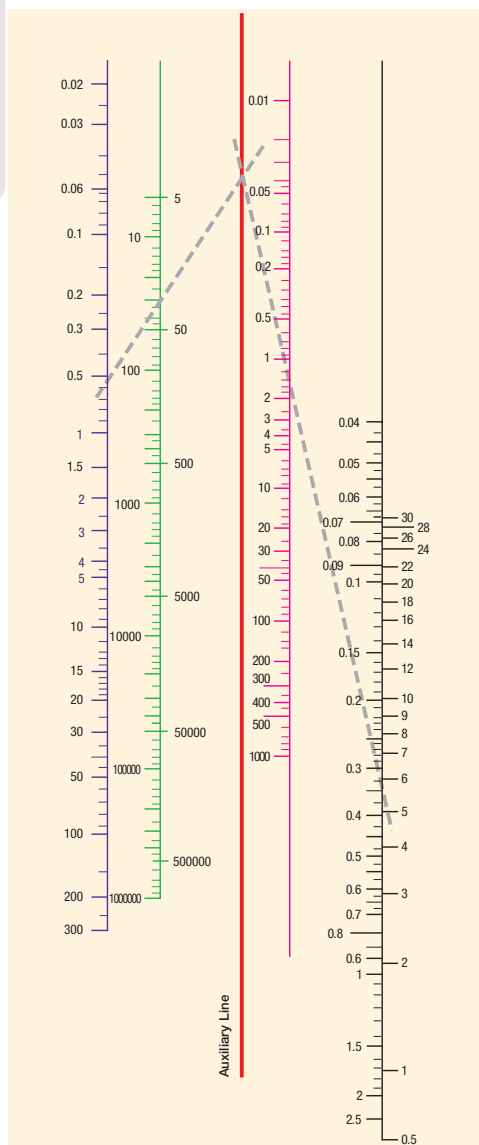

$K_v$  = Flow Coefficient

$Q_v$  = Flow Rate

$\Delta p$  = Pressure Drop

$V_s$  = Specific Volume

$P_2$  = Outlet Pressure

## Steam (Dry Saturated) Data

$P_2$ bar	Temp. °C	$V_s$ m <sup>3</sup> /Kg	$P_2$ bar	Temp. °C	$V_s$ m <sup>3</sup> /Kg
0.01	6.6	131.600	10.00	179.0	0.200
0.02	17.1	68.300	110.00	183.2	0.181
0.03	23.7	46.500	120.00	187.1	0.176
0.04	28.6	35.500	13.00	190.7	0.155
0.05	32.5	28.700	14.00	194.1	0.144
0.06	35.8	24.200	15.00	197.4	0.135
0.08	41.1	18.500	16.00	200.4	0.126
0.10	45.4	15.000	17.00	203.4	0.119
0.20	59.7	7.800	18.00	206.2	0.113
0.30	68.7	5.330	19.00	208.8	0.107
0.40	75.4	4.070	20.00	211.4	0.102
0.50	80.9	3.300	22.00	216.2	0.093
0.60	85.5	2.790	24.00	220.8	0.085
0.70	89.5	2.410	26.00	225.0	0.079
0.80	93.0	2.130	28.00	229.0	0.073
0.90	96.2	1.910	30.00	232.8	0.068
1.00	99.1	1.730	32.00	236.4	0.064
1.50	110.8	1.180	34.00	239.8	0.060
2.00	119.6	0.900	36.00	243.1	0.057
2.50	126.8	0.730	38.00	246.2	0.053
3.00	132.9	0.620	40.00	249.2	0.051
3.50	138.2	0.530	45.00	256.2	0.045
4.00	142.9	0.470	50.00	262.7	0.040
4.50	147.2	0.420	55.00	268.7	0.036
5.00	151.1	0.380	60.00	274.3	0.033
5.50	154.7	0.350	65.00	279.6	0.030
6.00	158.1	0.320	70.00	284.5	0.028
6.50	161.2	0.300	80.00	293.6	0.024
7.00	164.2	0.280	90.00	301.9	0.021
7.50	167.0	0.260	100.00	309.5	0.018
8.00	169.6	0.250	150.00	340.5	0.011
8.50	172.1	0.230	200.00	364.2	0.006
9.00	174.5	0.220	225.00	374.0	0.003
9.50	176.8	0.210			



## VISCOSITY CONVERSION TABLE

Centistokes cStokes mm <sup>2</sup> /S	°Engler °E	Saybolt Universal Second SSU	Rewood Second N°1 SRW N°1
1	1	-	-
12	2	65	55
22	3	100	90
30	4	140	120
28	5	175	155
45	6	210	185
60	8	275	245
75	10	345	305
90	12	415	370
115	15	525	465
150	20	685	610
200	26	910	810
300	39	1 385	1 215
400	53	1 820	1 620
500	66	2 275	2 025
750	97	3 365	2 995
1 500	197	6 820	6 075

## OTHER USEFUL FORMULAS

### Formulas:

$$^{\circ}\text{C} = (^{\circ}\text{F} - 32) \times 5/9$$

$$^{\circ}\text{F} = (^{\circ}\text{C} \times 9/5) + 32$$

$$\text{m}^3/\text{h} = \text{l}/\text{min} \times 0.06$$

$$\text{l}/\text{min} = \text{m}^3/\text{h} \times 16,67$$

$$\text{m}^3/\text{sec} = \text{m}^3/\text{h} \times 2,778 \times 10^{-4}$$

$$\text{m}^3/\text{sec} = \text{l}/\text{min} \times 1,667 \times 10^{-5}$$

### Examples:

$$(167^{\circ}\text{F} - 32) \times 5/9 = 75^{\circ}\text{C}$$

$$(30^{\circ}\text{C} \times 9/5) + 32 = 86^{\circ}\text{F}$$

$$100 \text{ l}/\text{min} \times 0.06 = 6 \text{ m}^3/\text{h}$$

$$9 \text{ m}^3/\text{h} \times 16,67 = 150 \text{ l}/\text{min}$$

$$18.000 \text{ m}^3/\text{h} \times 2.778 \times 10^{-4} = 5 \text{ m}^3/\text{sec}$$

$$479.904 \text{ l}/\text{min} \times 1.667 \times 10^{-5} = 8 \text{ m}^3/\text{sec}$$





**TABLE OF SUB-BASES FOR VALVES (Examples)**

Port Size	Part Number	Material	Kit Including	Compatible with Valves with
1/8" G	XGSPG1	AISI 304	fixing screws	any < 3.0 mm orifice
1/4" G	XGSPG2	AISI 304	fixing screws	any < 3.0 mm orifice
1/4" G	XGSPG3	AISI 304	fixing screws	4.0 mm to 5 mm orifice

# Liquipure® Adapter



N° 2 Fixing holes M5x0.8

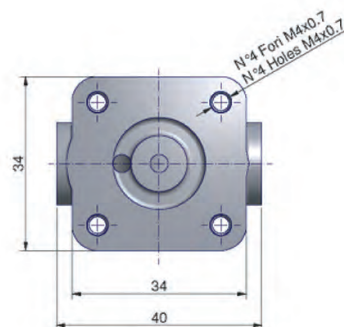
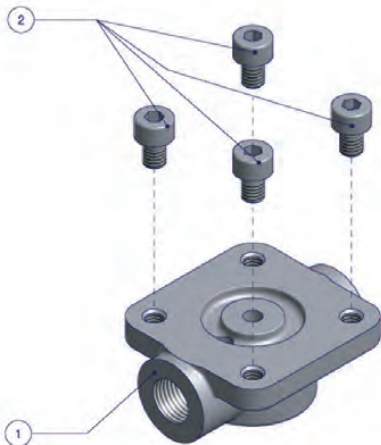
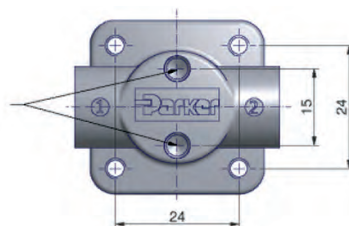

All dimensions are in mm



# APPENDIX

## TABLE OF VOLTAGE CODES FOR COILS AND ELECTRICAL PARTS

This table is showing the most commonly used voltage codes, for other voltages, please ask us.

VOLTAGE CODES			C1	C2	N7	L8	C4	C5	C7	E6	P1	A5	0A	S5	P2	1P	6J	0P	P3	K8	
Coil	Group	Sub-Group	12 DC	24 DC	28 DC	30 DC	48 DC	110 DC	196 DC	220 DC	100/50	100/50-60	110/50	110-115/50	110-115/50 120/60	110/50-60	110-115/50-60	110-115/60	100/50-115/60	110/50-120/60	115/60
481045	1.1	-	•	•			•	•						•			•				
481180	1.1	-	•	•				•						•							
481530	1.1	-	•	•				•						•							
482605	1.1	-	•	•				•						•							
482606	1.1	-	•	•			•	•		•				•				•			
483590	1.1	-	•	•				•						•							
488143	1.1	-	•	•				•						•							
488980	1.1	-	•	•			•	•						•				•			
492912	1.1	-	•	•				•						•							
492919	1.1	-	•	•				•						•							
495865	1.1	-	•	•			•	•						•				•			
496131	1.2	-	•	•			•	•						•							•
496637	1.2	-	•	•			•	•						•							•
WB4.5	1.3	-	•	•				•		•	•									•	
WB5.0	1.3	-	•	•				•													
WB8.0	1.3	-	•	•				•												•	
481000	2.0	2.1	•	•			•	•		•			•	•				•			•
481865	2.0	2.1	•	•			•	•					•								•
482635	2.0	2.1	•	•				•						•							
482725	2.0	2.1	•	•			•	•					•								•
483371	2.0	2.1	•	•			•	•		•				•				•			
483510	2.0	2.1	•	•				•						•							
483520	2.0	2.1	•	•				•						•							
485100	2.0	2.1	•	•				•		•				•							
488553	2.0	2.1	•	•				•			•										
488947	2.0	2.1	•	•				•			•										
491514	2.0	2.1	•	•		•		•											•		
492070	2.0	2.1	•	•			•	•								•					
492190	2.0	2.1	•	•			•	•		•						•					
492453	2.0	2.1	•	•			•	•					•								
492670	2.0	2.1	•	•			•	•					•								
492726	2.0	2.1	•	•				•													
493640	2.0	2.1	•	•			•	•					•							•	
494040	2.0	2.1	•	•				•		•				•							
495870	2.0	2.1	•	•			•	•					•								
495905	2.0	2.1	•	•			•	•					•								•
496081	2.0	2.1	•	•			•	•						•							
496082	2.0	2.1	•	•				•												•	
496110	2.0	2.1	•	•				•						•							
HZ10	2.0	2.1	•	•				•						•						•	
481044	2.0	2.2	•	•				•					•						•		
483816	2.0	2.2	•	•			•	•					•								
486265	2.0	2.2	•	•			•	•					•						•		
492425	2.0	2.2	•	•				•					•								
492727	2.0	2.2	•	•				•					•								
495880	2.0	2.2	•	•				•					•								
496155	2.0	2.2	•	•				•					•								
HZ11	2.0	2.2	•	•			•	•					•							•	
482730	3.0	-	•	•			•	•					•								•
482735	3.0	-	•	•			•	•					•								
495875	3.0	2.1	•	•				•													





## APPENDIX

### TABLE OF VOLTAGE CODES FOR COILS AND ELECTRICAL PARTS

This table is showing the most commonly used voltage codes, for other voltages, please ask us.

VOLTAGE CODES			C1	C2	N7	L8	C4	C5	C7	E6	P1	A5	0A	S5	P2	1P	6J	0P	P3	K8	
Coil	Group	Sub-Group	12 DC	24 DC	28 DC	30 DC	48 DC	110 DC	196 DC	220 DC	100/50	100/50-60	110/50	110-115/50	110-115/50 120/60	110/50-60	110-115/50-60	110-115/60	100/50-115/60	110/50-120/60	115/60
484990	4.0	-																			
485400	4.0	-	•	•			•	•													
495915	4.0	-		•			•											•			
482740	6.0	-		•			•	•													
482745	6.0	-		•																	
495900	6.0	-	•	•			•	•													
496125	6.0	-		•			•	•													•
483580.01	7.0	-			•																
488650.01	7.0	-			•																
488660.01	7.0	-			•																
488670.01	7.0	-			•																
490885	7.0	-				•															
490890	7.0	-			•	•															
495910	8.0	-			•																
492210	9.0	-		•																	
492965.01	9.0	-			•																
496565	9.0	-			•																
492300	10.1	-	•	•			•	•		•							•				
492310	10.1	-	•	•			•	•		•											
496560	10.1	-		•			•	•													•
496800	10.1	-		•			•	•													•
496800.02	10.1	-		•			•	•													•
496895	10.1	-		•			•	•													•
496555	10.2	-		•			•	•													•
496700	10.2	-		•			•	•													•
496700.02	10.2	-		•			•	•													•
497105	10.3	-	•	•			•	•													•
492335	12.0	-				•															
482870.01	12.0	-			•																
495294	13.0	-	•	•																	
496193	13.0	-	•	•																	
483824	14.1	-																			
483764	14.2	-																			
483541	14.3	-																			



## APPENDIX

### INDEX BY COIL REFERENCE

Coil Reference	Coil Group	Designation	Power DC Pn ( W )	Power AC Pn (W)	Ambient Temperature	UL	Degree of Protection	ATEX or NEMA 4X Protection (Gas)	Page
481000	2.0/2.1	Coil with screw terminal, 40 mm	8.0	8.0	-40°C to +50°C	-	IP 44 to 67	-	434
481044	2.0/2.2	Coil with screw terminal High power, 40 mm	-	14.0	-40°C to +50°C	-	IP 44 to 67	-	435
481180	1.1	Coil for DIN plug connection, 22 mm	5.0	4.0	-40°C to +50°C	-	IP65	-	425
481865	2.0 / 2.1	COILS FOR DIN PLUG CONNECTION 32 mm	9.0	8.0	-40°C to +50°C	-	IP65	-	418
482605	1.1	Explosion proof encapsulated electrical part "mb", 32 mm	5.0	4.0	-40°C to +65°C / +40°C	-	IP65	II 2 G Ex mb IIC T4/T5	453
482606	1.1	Explosion proof encapsulated electrical part "mb", low power, 32 mm	2.5	2.0	-40°C to +65°C/+35°C	-	IP65	II 2 G Ex mb IIC T4/T5	453
482730	3.0	COILS FOR DIN PLUG CONNECTION, REDUCED POWER, 32 mm	7.0	6.0	-40°C to +50°C	-	IP65	-	420
482740	6.0	COILS FOR DIN PLUG CONNECTION, low power, 32 mm	1.6	-	-40°C to +50°C	-	IP65	-	421
483371	2.0/2.1	Explosion proof increased safety electrical part "eb", 50 mm	8.0	8.0	-40°C to +65°C	-	IP67	II 2 G Ex eb IIC T4	462
483510	2.0 / 2.1	COILS FOR DIN PLUG CONNECTION 32 mm	-	9.0	-40°C to +50°C	-	IP65	-	418
483520	2.0/2.1	Coil with screw terminal, double frequency, 40 mm	-	9.0	-40°C to +50°C	-	IP 44 to 67	-	434
483541	14.3	Coil with screw terminal, high temperature-high power, 40 mm	20.0	20.0	-40°C to +50°C	-	IP 44 to 67	-	438
483590	1.1	Coil for DIN plug connection, double frequency, 22 mm	-	3.0	-40°C to +50°C	-	IP65	-	427
483764	14.2	Coil for DIN plug connection, UL recognized	-	9.0	-40°C to +50°C	-	IP65	-	423
483816	2.2	Coil for DIN plug connection for Jet Valves, 32 mm	14.0	14.0	-40°C to +50°C	-	IP65	-	424
483824	14.1	Coil with screw terminal, high temperature-high power, 40 mm	19.0	19.0	-40°C to +50°C	-	IP 44 to 67	-	437
484990	4.0	Coil with screw terminal, bistable, for impulse applications, 40 mm	-	11.0	-40°C to +50°C	-	IP 44 to 67	-	440
485400	4.0	Coil with screw terminal, bistable, for impulse applications, 40 mm	13.0	-	-40°C to +50°C	-	IP 44 to 67	-	440
486265	2.0/2.2	Coil with screw terminal, high temperature-high power, 40 mm	14.0	14.0	-40°C to +50°C	-	IP 44 to 67	-	436
488143	1.1	Coil for DIN plug connection, double frequency, 22 mm	-	2.5	-40°C to +50°C	-	IP65	-	428
488553	2.0/2.1	Coil with screw terminal, double frequency, H class, 40 mm	-	9.0	-40°C to +50°C	-	IP 44 to 67	-	439
488980	1.1	Coil for DIN plug connection, low power, 22 mm	2.5	2.0	-40°C to +50°C	-	IP65	-	425
490885	7.0	Explosion proof intrinsically safe electrical part, "NEMA", 50 mm	3.0	-	-40°C to +60°C	-	NEMA 4 - 4X	Cl. I, Div. I, Gr. A, B, C, D	470
491514	2.0/2.1	COILS FOR DIN PLUG CONNECTION, 32 mm, UL	-	11.0	-40°C to +50°C	-	IP65	-	422
492070	2.0/2.1	Explosion proof encapsulated electrical part "mb", with water proof metal housing, 50mm ( with 3 m cable length )	8.0	9.0	-40°C to +65°C	-	IP67	II 2 G Ex mb IIC T4/T5	454
492190	2.0/2.1	Explosion proof increased safety and encapsulated electrical part "eb", 50 mm	9.0	11.0	-40°C to +75°C	-	IP66	II 2 G Ex eb mb IIC T3/T4	465
492210	9.0	Explosion proof increased safety and encapsulated electrical part "eb", "Booster", 50 mm	1.0 to 1.8	-	-40°C to +75°C	-	IP66	II 2 G Ex eb mb IIC T5/T6	464
492310	10.1	Explosion proof increased safety and encapsulated electrical part "eb", 50 mm	6.0	6.0	-40°C to +75°C	-	IP66	II 2 G Ex eb mb IIC T4/T5	463
492425	2.0/2.2	COILS FOR DIN PLUG CONNECTION, HIGH TEMPERATURE, 32 mm	14.0	14.0	-40°C to +50°C	-	IP65	-	419
492453	2.0/2.1	COILS FOR DIN PLUG CONNECTION, HIGH TEMPERATURE, 32 mm	9.0	8.0	-40°C to +50°C	-	IP65	-	419
492912	1.1	Coil for DIN plug connection, 22 mm	4.0	3.0	-40°C to +50°C	-	IP65	-	426
493640	2.0/2.1	Flame proof encapsulated electrical part "db mb", double frequency	8.0	8.0	-40°C to +75°C	-	IP65	II 2 G Ex db mb IIC T4/T5	461
494040	2.0/2.1	Explosion proof increased safety electrical part "eb", 50 mm	8.0	8.0	-40°C to +90°C	-	IP67	II 2 G Ex eb IIC T3/T4	462
495294	13.0	Coil with ISO-DIN connector, 12-24VDC for transportation applications, 32 mm	9.0	-	-40°C to +120°C	-	IP69K	-	441
495865	1.1	Explosion proof electrical part "nAc nCc", low power, 22 mm	2.5	2.0	-40°C to +50°C	-	IP65	II 3 G Ex nAc nCc IIC T5	444
495870	2.0/2.1	Explosion proof electrical part "nAc nCc", 32 mm	9.0	8.0	-40°C to +50°C	-	IP65	II 3 G Ex nAc nCc IIC T3/T4	446
495875	3.0	Explosion proof electrical part "nAc nCc", 32 mm	7.0	6.0	-40°C to +50°C	-	IP65	II 3 G Ex nAc nCc IIC T3/T4	448
495880	2.0/2.2	Explosion proof electrical part "nAc nCc", 32 mm	14.0	14.0	-40°C to +50°C	-	IP65	II 3 G Ex nAc nCc IIC T3	449
495900	6.0	Flame proof encapsulated electrical part "db mb", low power, 37 mm	2.0	2.5	-40°C to +65°C	-	IP67	II 2 G Ex db mb IIC T4 / T5/T6	457

## INDEX BY COIL REFERENCE

Coil Reference	Coil Group	Designation	Power DC Pn (W)	Power AC Pn (W)	Ambient Temperature	UL	Degree of Protection	ATEX or NEMA 4X Protection (Gas)	Page
495905	2.0/2.1	Flame proof encapsulated electrical part "db mb", 37 mm	8.0	8.0	-40°C to +65°C	-	IP67	II 2 G Ex db mb IIC T4	458
495910	8.0	Explosion proof intrinsically safe electrical part "a", "booster", 37 mm	0.3 to 1.2	-	-40°C to +80°C	-	IP67	II 1 G Ex ia IIC T4/T5/T6	467
495915	4.0	Explosion proof increased safety electrical part "nAc nCc", 50 mm	13.0	11.0	-40°C to +65°C	-	IP67	II 3 G Ex nAc nCc IIC T3	450
496081	2.0/2.1	Coil with flying leads, IP 67, 32 mm	9.0	9.0	-40°C to +50°C	-	IP67	-	432
496110	2.0/2.1	Explosion proof electrical part "nAc nCc", 32 mm	-	9.0	-40°C to +50°C	-	IP65	II 3 G Ex nAc nCc IIC T3/T4	446
496125	6.0	Explosion proof electrical part "nAc nCc", low power, 32 mm	1.6	-	-40°C to +50°C	-	IP65	II 3 G Ex nAc nCc IIC T5/T6	447
496131	1.2	Coil for DIN plug connection, double frequency, 22 mm	3.0	3.0	-40°C to +50°C	-	IP65	-	429
496155	2.0/2.2	Explosion proof increased safety electrical part "nAc nCc", 50 mm	14.0	14.0	-40°C to +65°C	-	IP67	II 3 G Ex nAc nCc IIC T3	451
496193	13.0	Coil with ISO-DIN connector, 12-24VDC, for transportation applications, 32 mm	9.0	-	-40°C to +20°C	-	IP69K	-	441
496482	1.2	Coil for DIN plug connection, double frequency coil, 22 mm	3.0	3.0	-40°C to +50°C	-	IP65	-	430
496555	10.2	Flame proof encapsulated electrical part "db mb", 37 mm	6.0	6.0	-40°C to +65°C	-	IP67	II 2 G Ex db mb IIC T4/T5/T6	459
496560	10.1	Flame proof encapsulated electrical part "db mb", 37 mm	8.0	8.0	-40°C to +65°C	-	IP67	II 2 G Ex db mb IIC T4	459
496565	9.0	Explosion proof intrinsically safe electrical part "a", "Booster", 37 mm	0.77 to 2.58	-	-40°C to +80°C	-	IP67	II 1 G Ex ia IIC T4/T5/T6	468
496637	1.2	Explosion proof electrical part "nAc nCc", double frequency, 22 mm	3.0	3.0	-20°C to +50°C	-	IP65	II 3 D Ex TC IIIC T 95°C	445
496700	10.2	Flame proof encapsulated electrical part "db mb", 37 mm	6.0	6.0	-40°C to +65°C	-	IP67	II 2 G Ex db mb IIC T4 / T5 / T6	460
496800	10.1	Flame proof encapsulated electrical part "db mb", 37 mm	8.0	8.0	-40°C to +65°C	-	IP67	II 2 G Ex db mb IIC T4	460
496895	10.1	Coil for DIN plug connection for oil and gas, 37 mm	8.0	8.0	-40°C to +50°C	-	IP65	-	431
497105	10.3	Flame proof stainless steel electrical part "db", M20x1.5	8.0	8.0	-50°C to +80°C / +60°C / +40°C	-	IP66	II 2 G Ex db IIC T4/T5/T6	452
482606.160	1.1	Explosion proof encapsulated electrical part "mb", low power, 32 mm	2.5	2.0	-40°C to +65°C / +35°C	-	IP65	II 2 G Ex mb IIC T4/T5	453
492070.160	2.0/2.1	Explosion proof encapsulated electrical part "mb", with water proof metal housing, 50mm ( with 6 m cable length )	8.0	9.0	-40°C to +65°C	-	IP67	II 2 G Ex mb IIC T4/T5	454
483580.01	7.0	Explosion proof intrinsically safe electrical part "a", 32 mm	3.0	-	-40°C to +55°C	-	IP65	II 1 G Ex ia IIC T6	466
483960.01	7.0	Explosion proof intrinsically safe electrical part "a", 32 mm	3.0	-	-40°C to +55°C	-	IP65	II 1 G Ex ia IIC T6	466
488650.01	7.0	Explosion proof intrinsically safe electrical part "a", 50 mm	0.3 to 3.0	-	-40°C to +65°C	-	IP66	II 1 G Ex ia IIC T6	470
492965.01	9.0	Explosion proof intrinsically safe electrical part "a", "Booster", 50 mm (stainless steel fixation)	0.3 to 2.3	-	-40°C to +65°C	-	IP66	II 1 G Ex ia IIC T6	469
492965.02	9.0	Explosion proof intrinsically safe electrical part "a", "Booster", 50 mm (Plastic fixation)	0.3 to 2.3	-	-40°C to +65°C	-	IP66	II 1 G Ex ia IIC T6	469
493640.60*	2.0/2.1	Flame proof encapsulated electrical part "db mb", double frequency	8.0	8.0	-40°C to +75°C	-	IP65	II 2 G Ex db mb IIC T4/T5	461
495905.05*	2.0/2.1	Flame proof encapsulated electrical part "db mb", 37 mm	8.0	8.0	-40°C to +65°C	-	IP67	II 2 G Ex db mb IIC T4	458
496700.02	10.2	Flame proof encapsulated electrical part "db mb", 37 mm	6.0	6.0	-40°C to +65°C	-	IP67	II 2 G Ex db mb IIC T4 / T5 / T6	460
496800.02	10.1	Flame proof encapsulated electrical part "db mb", 37 mm	8.0	8.0	-40°C to +65°C	-	IP67	II 2 G Ex db mb IIC T4	460
497105.02	10.3	Flame proof stainless steel electrical part "db", NPT 1/2"	8.0	8.0	-50°C to +80°C / +60°C / +40°C	-	IP66	II 2 G Ex db IIC T4/T5/T6	452
HZ10	2.0/2.1	Explosion proof encapsulated electrical part "mb", double frequency	8.0	8.0	-40°C to +85°C	-	IP65	II 2 G Ex mb IIC T3/T4/T5	455
HZ11		Explosion proof encapsulated electrical part "mb", double frequency	14.0	14.0	-40°C to +85°C	-	IP65	II 2 G Ex mb IIC T3/T4/T5	456

# APPENDIX

## INDEX BY COIL GROUP

Coil Group	Coil Reference	Designation	Power DC Pn (W)	Power AC Pn (W)	Ambient Temperature	UL	Degree of Protection	ATEX or NEMA 4X Protection (Gas)	Page
1.1	481180	COIL FOR DIN PLUG CONNECTION, 22 MM	5.0	4.0	-40°C TO +50°C	-	IP65	-	425
1.1	483590	COIL FOR DIN PLUG CONNECTION,DOUBLE FREQUENCY, 22 MM	-	3.0	-40°C TO +50°C	-	IP65	-	427
1.1	488143	COIL FOR DIN PLUG CONNECTION,DOUBLE FREQUENCY, 22 MM	-	2.5	-40°C TO +50°C	-	IP65	-	428
1.1	495865	EXPLOSION PROOF ELECTRICAL PART "NAC NCC", LOW POWER, 22 MM	2.5	2.0	-40°C TO +50°C	-	IP65	II 3 G Ex nA c nC c IIC T5	444
1.1	482605	EXPLOSION PROOF ENCAPSULATED ELECTRICAL PART "MB", 32 MM	5.0	4.0	-40°C TO +65°C / +40°C	-	IP65	II 2 G EX MB IIC T4/T5	453
1.1	482606	EXPLOSION PROOF ENCAPSULATED ELECTRICAL PART "MB", LOW POWER, 32 MM	2.5	2.0	-40°C TO +65°C/+35°C	-	IP65	II 2 G EX MB IIC T4/T5	453
1.1	482606.160	EXPLOSION PROOF ENCAPSULATED ELECTRICAL PART "MB", LOW POWER, 32 MM	2.5	2.0	-40°C TO +65°C/+35°C	-	IP65	II 2 G EX MB IIC T4/T5	453
1.1	488980	COIL FOR DIN PLUG CONNECTION, LOW POWER, 22 MM	2.5	2.0	-40°C TO +50°C	-	IP65	-	425
1.1	492912	COIL FOR DIN PLUG CONNECTION, 22 MM	4.0	3.0	-40°C TO +50°C	-	IP65	-	426
1.2	496482	COIL FOR DIN PLUG CONNECTION, DOUBLE FREQUENCY COIL, 22 MM	3.0	3.0	-40°C TO +50°C	-	IP65	-	430
1.2	496637	EXPLOSION PROOF ELECTRICAL PART "NAC NCC", DOUBLE FREQUENCY, 22 MM	3.0	3.0	-20°C TO +50°C	-	IP65	II 3 D EX TC IIIC T 95°C	445
1.2	496131	COIL FOR DIN PLUG CONNECTION, DOUBLE FREQUENCY, 22 MM	3.0	3.0	-40°C TO +50°C	-	IP65	-	429
2.0/2.1	481865	COILS FOR DIN PLUG CONNECTION 32 MM	9.0	8.0	-40°C TO +50°C	-	IP65	-	418
2.0/2.1	483510	COILS FOR DIN PLUG CONNECTION 32 MM	-	9.0	-40°C TO +50°C	-	IP65	-	418
2.0/2.1	492453	COILS FOR DIN PLUG CONNECTION, HIGH TEMPERATURE, 32 MM	9.0	8.0	-40°C TO +50°C	-	IP65	-	419
2.0/2.1	491514	COILS FOR DIN PLUG CONNECTION, 32 MM, UL	-	11.0	-40°C TO +50°C	-	IP65	-	422
2.0/2.1	496081	COIL WITH FLYING LEADS,IP 67, 32 MM	9.0	9.0	-40°C TO +50°C	-	IP67	-	432
2.0/2.1	481000	COIL WITH SCREW TERMINAL, 40 MM	8.0	8.0	-40°C TO +50°C	-	IP 44 TO 67	-	434
2.0/2.1	483520	COIL WITH SCREW TERMINAL, DOUBLE FREQUENCY, 40 MM	-	9.0	-40°C TO +50°C	-	IP 44 TO 67	-	434
2.0/2.1	495870	EXPLOSION PROOF ELECTRICAL PART "NAC NCC", 32 MM	9.0	8.0	-40°C TO +50°C	-	IP65	II 3 G EX NAC NCC IIC T3/T4	446
2.0/2.1	496110	EXPLOSION PROOF ELECTRICAL PART "NAC NCC", 32 MM	-	9.0	-40°C TO +50°C	-	IP65	II 3 G EX NAC NCC IIC T3/T4	446
2.0/2.1	492070	EXPLOSION PROOF ENCAPSULATED ELECTRICAL PART "MB", WITH WATER PROOF METAL HOUSING, 50MM ( WITH 3 M CABLE LENGTH )	8.0	9.0	-40°C TO +65°C	-	IP67	II 2 G EX MB IIC T4/T5	454
2.0/2.1	492070.60	EXPLOSION PROOF ENCAPSULATED ELECTRICAL PART "MB", WITH WATER PROOF METAL HOUSING, 50MM ( WITH 6 M CABLE LENGTH )	8.0	9.0	-40°C TO +65°C	-	IP67	II 2 G EX MB IIC T3/T4/T5	454
2.0/2.1	HZ10	EXPLOSION PROOF ENCAPSULATED ELECTRICAL PART "MB", DOUBLE FREQUENCY	8.0	8.0	-40°C TO +85°C	-	IP65	II 2 G EX MB IIC T3/T4/T5	455
2.0/2.1	HZ11	EXPLOSION PROOF ENCAPSULATED ELECTRICAL PART "MB", DOUBLE FREQUENCY	14.0	14.0	-40°C TO +85°C	-	IP65	II 2 G EX MB IIC T3/T4/T5	456
2.0/2.1	495905	FLAME PROOF ENCAPSULATED ELECTRICAL PART "DB MB", 37 MM	8.0	8.0	-40°C TO +65°C	-	IP67	II 2 G EX DB MB IIC T4	458
2.0/2.1	495905.05*	FLAME PROOF ENCAPSULATED ELECTRICAL PART "DB MB", 37 MM	8.0	8.0	-40°C TO +65°C	-	IP67	II 2 G EX DB MB IIC T4	458
2.0/2.1	493640	FLAME PROOF ENCAPSULATED ELECTRICAL PART "DB MB", DOUBLE FREQUENCY	8.0	8.0	-40°C TO +75°C	-	IP65	II 2 G EX DB MB IIC T4/T5	461
2.0/2.1	493640.60*	FLAME PROOF ENCAPSULATED ELECTRICAL PART "DB MB", DOUBLE FREQUENCY	8.0	8.0	-40°C TO +75°C	-	IP65	II 2 G EX DB MB IIC T4/T5	461
2.0/2.1	483371	EXPLOSION PROOF INCREASED SAFETY ELECTRICAL PART "EB", 50 MM	8.0	8.0	-40°C TO +65°C	-	IP67	II 2 G EX EB IIC T4	462
2.0/2.1	494040	EXPLOSION PROOF INCREASED SAFETY ELECTRICAL PART "EB", 50 MM	8.0	8.0	-40°C TO +90°C	-	IP67	II 2 G EX EB IIC T3/T4	462
2.0/2.1	492190	EXPLOSION PROOF INCREASED SAFETY AND ENCAPSULATED ELECTRICAL PART "EB", 50 MM	9.0	11.0	-40°C TO +75°C	-	IP66	II 2 G EX EB MB IIC T3/T4	465
2.0/2.1	488553	COIL WITH SCREW TERMINAL,DOUBLE FREQUENCY, H CLASS, 40 MM	-	9.0	-40°C TO +50°C	-	IP 44 TO 67	-	439
2.0/2.2	492425	COILS FOR DIN PLUG CONNECTION, HIGH TEMPERATURE, 32 MM	14.0	14.0	-40°C TO +50°C	-	IP65	-	419
2.0/2.2	481044	COIL WITH SCREW TERMINAL HIGH POWER, 40 MM	-	14.0	-40°C TO +50°C	-	IP 44 TO 67	-	435
2.0/2.2	486265	COIL WITH SCREW TERMINAL,HIGH TEMPERATURE-HIGH POWER, 40 MM	14.0	14.0	-40°C TO +50°C	-	IP 44 TO 67	-	436
2.0/2.2	495880	EXPLOSION PROOF ELECTRICAL PART "NAC NCC", 32 MM	14.0	14.0	-40°C TO +50°C	-	IP65	II 3 G EX NAC NCC IIC T3	449
2.0/2.2	496155	EXPLOSION PROOF INCREASED SAFETY ELECTRICAL PART "NAC NCC", 50 MM	14.0	14.0	-40°C TO +65°C	-	IP67	II 3 G EX NAC NCC IIC T3	451
2.2	483816	COIL FOR DIN PLUG CONNECTION FOR JET VALVES, 32 MM	14.0	14.0	-40°C TO +50°C	-	IP65	-	424

## INDEX BY COIL GROUP

Coil Group	Coil Reference	Designation	Power DC Pn ( W )	Power AC Pn ( W )	Ambient Temperature	UL	Degree of Protection	ATEX or NEMA 4X Protection (Gas)	Page
3.0	482730	COILS FOR DIN PLUG CONNECTION, REDUCED POWER, 32 MM	7.0	6.0	-40°C TO +50°C	-	IP65	-	420
3.0	495875	EXPLOSION PROOF ELECTRICAL PART "NAC NCC", 32 MM	7.0	6.0	-40°C TO +50°C	-	IP65	II 3 G EX NAC NCC IIC T3/T4	448

## APPENDIX

### INDEX BY VALVE REFERENCE

Valve Reference	Page	Valve Reference	Page	Valve Reference	Page	Valve Reference	Page
E 131E03	178,274	E 121K0352	24,62	121KH1050	138	122K8406	28,114
U 033X0111	298	121K0397	24	121M13	22,62	122K9321	158
U 033X5156	370	E 121K04	22,112	121M14	22,62	122K9363	28,114
U 033X5195	374	E 121K0402	22,62	121V5106	130	122V8306	132
U 033X5256	376	121K0497	22	121V5112	130	125K01	28,66
U 033X7759	372	E 121K07	22	121V5163	104,130	125K03	28
121F2523	158	121K0706	22,62	121V5206	130	131B04	192
E 121F43	30,116	121K1302	22	121V5212	130	131B14	192
E 121F4302	30,68	E 121K14	22,112	121V5263	104,130	E 131F26	196
E 121F44	30,116	E 121K23	22,112	121V5306	128	E 131F43	188
E 121F4406	30,68	121K2423	156	121V5363	104,128	E 131F4350	188
121F4417	30	121K3106	26,64,114	121V5397	130	131F4397	280
121F47	30	121K3206	26,64,114	121V5406	128	E 131F44	188
121F4706	30,116	121K3303	102	121V5463	104,128	131F4410	186
121F63	30,116	121K3306	26,64,114	121V5497	128	E 131F4450	188
121F64	30,116	121K3321	156	U 121V5595	148	131F4490	186
121F67	30,116	E 121K45	26,64	121V5706	128	131F46	188
121FH0015	138	E 121K4503	102	121V5763	104,128	131F4650	188
121FH0020	138	E 121K46	26,64	U 121V7595	148	U 131F5295	354
121FH0025	138	E 121K4603	102	U 121VS3750A	148	131F5406	194
121FH0030	138	121K6220	156	121ZH0010	136	U 131F7695	354
121FH1015	138	E 121K63	24,112	121ZH0015	136	131FH0315	226
121FH1020	138	E 121K64	24,112	121ZH0020	136	131FH0320	226
121FH1025	138	121K6423	156	121ZH0025	136	131FH0325	226
121FH1030	138	E 121K65	22,112	121ZH0030	136	131FH0330	226
121G2520	156	E 121K67	22,112	121ZH1010	136	131FH1115	226
121G2523	156	121KH0015	138	121ZH1015	136	131FH1120	226
121K01	24,62	121KH0020	138	121ZH1020	136	131FH1125	226
121K0103	102	121KH0025	138	121ZH1025	136	131FH1130	226
121K0150	24,62	121KH0030	138	121ZH1030	136	131FH1315	226
121K02	24,62	121KH1015	138	122F44	32	131FH1320	226
121K0250	24,62	121KH1020	138	122K83	28	131FH1325	226
E 121K03	24,112	121KH1025	138	122K8306	28,64	131FH1330	226
E 121K0302	24,62	121KH1030	138	122K8321	156,114	E 131K03	178
121K0323	102	121KH1040	138	122K84	28,114	E 131K0308	178,274

## INDEX BY VALVE REFERENCE

Valve Reference	Page	Valve Reference	Page	Valve Reference	Page	Valve Reference	Page
E 131K0350	178,274	131T2101	274	132K04	180	U 133X5196	346
E 131K0358	176,270	131T22	178	132K06	180	U 133X5296	352
131K0397	176	131T23	174	132T22	180	U 133X7195	356
E 131K04	174,272	131T2301	174	132T23	180	U 133X7709	348
E 131K0450	174,272	131T29	176	132T2301	178	U 133X77591	348
131K0490	172,270	131T2901	176	132T29	180	135K03	278
131K0497	174,270	131V5306	214	133F4650	280	135K04	184
E 131K06	176,272	131V5363	214	E 133K03	182	2019F1GRG7	140
131K0648	240	131V5397	214	E 133K0350	182	2019F1GVG7	140
E 131K0650	176,272	131V5406	214	E 133K04	182	2019F1JRG7	140
E 131K13	172	131V5463	214	E 133K0450	182	2019F1JVG7	140
E 131K14	172	131V5490	214	133K0497	182	2019F1LRG7	140
131K16	172	131V5497	214	E 133K05	182	2019F1LVG7	140
131K1650	172	131X1101	302	E 133K06	182	2019F1NRG7	140
E 131K63	178	U 131X1101	302	E 133K0650	182	2019F1NVG7	140
E 131K6350	178	131X1131	302	E 133K13	182	2019F1QEG7	140
E 131K64	174	U 131X1201	356	E 133K14	182	2019F1QVG7	140
E 131K6450	174	131ZH0125	222	E 133K16	182	2019F1SEG7	140
131KH0115	224	131ZH0130	222	133T21	182	2019F1SVG7	140
131KH0120	224	131ZH0315	222	133T2101	184	201LG1GVG2	144
131KH0125	224	131ZH0320	222	133T23	182	201LG1JVG2	144
131KH0130	224	131ZH0325	222	133T2301	182	201LG1LVG2	144
131KH1115	224	131ZH0330	222	133V5306	216	201LG2GVG2	144
131KH1120	224	131ZH1115	222	133V5363	216	201LG2JVG2	144
131KH1125	224	131ZH1120	222	133V5406	216	201LG2LVG2	144
131KH1130	224	131ZH1125	222	133V5463	216	201LG2NVG7	144
131KH1140	224	131ZH1130	222	U 133V5595	344	201LG3SVG7	144
131KH1150	224	131ZH1315	222	U 133V5695	344	201LG3UVG7	144
131M14	172,270	131ZH1320	222	U 133V7595	344	201LG4SVG6	144
131M15	172,270	131ZH1325	222	U 133V7695	344	201LG4UVG7	144
131M74	186	131ZH1330	222	133X01	282	202LG2NVG7	146
131M7450	186	132F43	188	U 133X01	282	202LG2SVG7	146
131M75	186	132F44	188	U 133X0111	276	202LG4SVG7	146
131M7550	186	132F46	188	U 133X5156	346	202LG4UVG7	146
131T21	178	132K03	180	U 133X5195	354	221G13	34

## APPENDIX

### INDEX FOR VALVES

Valve Reference	Page	Valve Reference	Page	Valve Reference	Page	Valve Reference	Page
221G1303	106	221G6506	150	321F2523	164	E 321K13	42,74
221G1330	106	221G6536	150	E 321F32	58,86	E 321K1314	42
221G15	34	221G6606	152	E 321F3202	58,124	E 321K15	44,76
221G1503	106	221G6636	152	321F35	58	E 321K1503	108
221G1530	34	221J3301E	168	E 321G36	46,78	321K1523	236
221G16	36	3019F1GRG7	198,228	E 321G3606	46	321K1535	234
221G1603	106	3019F1GVG7	198,228	E 321G3610	94	321K1536	236
221G1610	36	3019F1JRG7	198,228	E 321G37	48,80	321K1537	236
221G1630	36	3019F1JVG7	198,228	E 321G3706	48	321K1543	234
221G1631	36	3019F1LRG7	198,228	E 321G3710	96	E 321K25	44,76
221G17	38	3019F1LVG7	198,228	321G3790	48	321K31	40,74
221G1703	106	3019F1NRG7	198,228	E 321G38	48,80	321K3106	40
221G1710	38	3019F1NVG7	198,228	E 321G3806	48	321K33	42,74
221G1730	38	3019F1QEG7	198,228	E 321G3810	96	321K3306	42
221G1731	90	3019F1QVG7	198,228	E 321G39	50,80	321K35	44,76
221G21	38	3019F1SEG7	198,228	E 321G3906	50	321K3506	44
221G2103	90	3019F1SVG7	198,228	E 321G3910	96	321K36	46,78
221G2106	38	301LG1GVG2	220	321G3990	50	321K3606	46
221G2110	38	301LG1LVG2	220	E 321G40	50,80	321K37	48,80
221G2130	38	301LG2GVG2	220	E 321G4006	50	321K3706	48
221G2131	90	301LG2GVG7	220	E 321G4010	96	321K4106	74,94
221G2136	38	301LG2LVG2	220	321G4090	50	321K4156	40
221G23	34	301LG2NVG7	220	E 321H11	40,118	321K4306	74,94
221G2330	34	301XGFRTJ7	228	E 321H13	42,118	321K4356	42
221G25	34	3039F1GEG7	198,224	E 321H15	44,120	321K4506	76,94
221G2523	160	3039F1GVG7	200	321H1590	44	321K4556	76,94
221G2530	34	3039F1JEG7	200,230	E 321H21	118,162	321K4606	78,94
221G26	36	3039F1JVG7	200,230	E 321H23	118,162	321K4656	78,94
221G2630	36	3039F1JVG7	200,230	321H2322	162	321K4706	80,96
221G27	38	3039F1LEG7	200,230	E 321H25	120,164	321K4756	80,96
221G2730	38	3039F1LVG7	200,230	321H2522	164	E 321K63	118
221G6106	152	3039F1LVG7	200,230	321H2523	164	322F35	58
221G6136	152	3039F1NEG7	200,230	321H35	44	322F72	58
221G6306	150	3039F1NVG7	200,230	321H36	46	322F7206	58,124
221G6336	150	3039F1NVG7	200,230	E 321K10	40,74	322G36	54,84

## INDEX FOR VALVES

Valve Reference	Page	Valve Reference	Page	Valve Reference	Page	Valve Reference	Page
322G3606	54	331B02	210	341L9504	330	341P02	286
322G3610	98	331B0216	210	341L9534	330	U 341P0250	358
322G37	54,86	E 331B21	204	341L9594	332	341P03	286
322G3706	54	E 331B74	202	341L9597	332	341P04	290
322G3710	98	331B7490	202	341L9598	332	341P21	284
322G38	54	E 331L21	206	341N01	308	341P2108	284
322G3806	54	331N03	304	341N02	314	341P2190	286
322G3810	98	331N04	304	U 341N0250	366	341P2197	284
322G39	54,86	331N34	306	341N04	318	341P22	288
322G3906	54	E 332B01	204	341N05	312	341P2290	288
322G3910	98	332B02	204	341N0502	314	341P2297	288
322G40	54	E 332B21	206	341N11	308	U 341P3250	358
322G4006	54	E 341B01	246	341N12	316	U 341P3292	360
322G4010	98	341B02	244	341N21	308	U 341P3295	360
322G75	52,84	E 341B21	246	341N2190	308	341P33	286
322G7506	52,122	341B34	244	341N22	316	341P34	290
322H35	52	341B3403	244	341N31	310	342N03	326
322H36	54	341B3440	244	341N3102	310	342N11	326
322H71	52	341B3490	244	341N3108	310	342N3197	326
322H7106	52,122	E 341F21	246	341N3128	310	342N33	326
322H73	52,122	341F34	252	341N3130	310	343N03	328
322H7306	52,122	341F3403	252	341N3190	310	345B04	248
322H75	52,122	341F3440	252	341N3196	310	345B34	248
322H7506	52,122	E 341L01	262	341N3197	310	345F34	252
322K4106	84	341L0197	262	341N32	316	345L01	264
322K4306	84	E 341L02	260	341N3202	316	345L21	256
322K4506	84	341L04	262	U 341N3250	364	345N31	330
322K4606	84	341L05	262	341N3290	312	345P21	296
322K4706	86	341L11	258	U 341N3292	364	347L04	256
325K4106	56	E 341L1130	258	U 341N3295	364	347L11	260
325K4306	56	U 341L1130	258	341N3297	312	E 347L1130	260
325K4506	56	E 341L21	254	341N34	318	347L9101	250
325K4606	56	341L2190	254	341N35	314	347L9201	256
325K4706	56	341L9101	250	341N3502	314	347N03	322
E 331B01	202	341L9201	254	341P01	284	347N04	324

## INDEX FOR VALVES

Valve Reference	Page	Valve Reference	Page	Valve Reference	Page
347N11	320	443788W	92	444601W	82
347N12	322	443789W	70	444602W	82
347N31	320	443790W	72	444603W	82
347N3190	320	443791W	72	444604W	82
347N3197	320	443792W	92	444605W	82
347N32	322	443793W	72	542N03	340
U 347N3250	368	443794W	72	547N03	338
347N33	322	443795W	72		
347N34	324	443796W	92		
347P01	292	443797W	72		
347P02	294	443798W	72		
347P03	294	443799W	72		
347P04	296	443800W	92		
347P21	292	443801W	72		
347P2190	292	443802W	92		
347P2197	292	443803W	92		
347P22	294	443804W	70		
U 347P3250	362	443805W	82		
U 347P3295	362	443806W	82		
347P33	294	443807W	82		
347P34	296	443808W	82		
421F35	58	443809W	82		
U 441P3250	358	443810W	82		
443776W	70	443811W	82		
443777W	70	444492W	70		
443778W	70	444494W	70		
443779W	70	444497W	70		
443780W	70	444499W	82		
443781W	70	444500W	82		
443782W	70	444501W	82		
443783W	70	444502W	82		
443784W	92	444503W	82		
443785W	70	444513W	82		
443786W	70	444576W	82		
443787W	70	444600W	82		







# Parker's Motion & Control Technologies

At Parker, we're guided by a relentless drive to help our customers become more productive and achieve higher levels of profitability by engineering the best systems for their requirements. It means looking at customer applications from many angles to find new ways to create value.

Whatever the motion and control technology need, Parker has the experience, breadth of product and global reach to consistently deliver. No company knows more about motion and control technology than Parker.

For further info call  
00800 27 27 5374



## Aerospace

### Key Markets

Aftermarket services  
Commercial  
engines  
Engines  
General & business aviation  
Helicopters  
Launch vehicles  
Military aircraft  
Missiles  
Power generation  
Regional transports  
Unmanned aerial vehicles

### Key Products

Control systems & actuation products  
Engine systems & components  
Fluid conveyance systems & components  
Fluid metering, delivery & atomization devices  
Fuel systems & components  
Fuel tank inerting systems  
Hydraulic systems & components  
Thermal management  
Wheels & brakes



## Climate Control

### Key Markets

Agriculture  
Air conditioning  
Construction Machinery  
Food & beverage  
Industrial machinery  
Life sciences  
Oil & gas  
Precision cooling  
Process  
Refrigeration  
Transportation

### Key Products

Accumulators  
Advanced actuators  
CO<sub>2</sub> controls  
Electronic controllers  
Filter driers  
Hand shut-off valves  
Heat exchangers  
Hose & fittings  
Pressure regulating valves  
Refrigerant distributors  
Safety relief valves  
Smart pumps  
Solenoid valves  
Thermostatic expansion valves



## Hydraulics

### Key Markets

Aerial lift  
Agriculture  
Alternative energy  
Construction machinery  
Forestry  
Industrial machinery  
Machine tools  
Marine  
Material handling  
Mining  
Oil & gas  
Power generation  
Refuse vehicles  
Renewable energy  
Truck hydraulics  
Turf equipment

### Key Products

Accumulators  
Cartridge valves  
Electrohydraulic actuators  
Human machine interfaces  
Hybrid drives  
Hydraulic cylinders  
Hydraulic motors & pumps  
Hydraulic systems  
Hydraulic valves & controls  
Hydrostatic steering  
Integrated hydraulic circuits  
Power take-offs  
Power units  
Rotary actuators  
Sensors



## Pneumatics

### Key Markets

Aerospace  
Conveyor & material handling  
Factory automation  
Life science & medical  
Machine tools  
Packaging machinery  
Transportation & automotive

### Key Products

Air preparation  
Brass fittings & valves  
Manifolds  
Pneumatic accessories  
Pneumatic actuators & grippers  
Pneumatic valves & controls  
Quick disconnects  
Rotary actuators  
Rubber & thermoplastic hose & couplings  
Structural extrusions  
Thermoplastic tubing & fittings  
Vacuum generators, cups & sensors



## Electromechanical

### Key Markets

Aerospace  
 Factory automation  
 Life science & medical  
 Machine tools  
 Packaging machinery  
 Paper machinery  
 Plastics machinery & converting  
 Primary metals  
 Semiconductor & electronics  
 Textile  
 Wire & cable

### Key Products

AC/DC drives & systems  
 Electric actuators, gantry robots & slides  
 Electrohydraulic actuation systems  
 Electromechanical actuation systems  
 Human machine interface  
 Linear motors  
 Stepper motors, servo motors, drives & controls  
 Structural extrusions



## Filtration

### Key Markets

Aerospace  
 Food & beverage  
 Industrial plant & equipment  
 Life sciences  
 Marine  
 Mobile equipment  
 Oil & gas  
 Power generation & renewable energy  
 Process  
 Transportation  
 Water Purification

### Key Products

Analytical gas generators  
 Compressed air filters & dryers  
 Engine air, coolant, fuel & oil filtration systems  
 Fluid condition monitoring systems  
 Hydraulic & lubrication filters  
 Hydrogen, nitrogen & zero air generators  
 Instrumentation filters  
 Membrane & fiber filters  
 Microfiltration  
 Sterile air filtration  
 Water desalination & purification filters & systems



## Fluid & Gas Handling

### Key Markets

Aerial lift  
 Agriculture  
 Bulk chemical handling  
 Construction machinery  
 Food & beverage  
 Fuel & gas delivery  
 Industrial machinery  
 Life sciences  
 Marine  
 Mining  
 Mobile  
 Oil & gas  
 Renewable energy  
 Transportation

### Key Products

Check valves  
 Connectors for low pressure fluid conveyance  
 Deep sea umbilicals  
 Diagnostic equipment  
 Hose couplings  
 Industrial hose  
 Mooring systems & power cables  
 PTFE hose & tubing  
 Quick couplings  
 Rubber & thermoplastic hose  
 Tube fittings & adapters  
 Tubing & plastic fittings



## Process Control

### Key Markets

Alternative fuels  
 Biopharmaceuticals  
 Chemical & refining  
 Food & beverage  
 Marine & shipbuilding  
 Medical & dental  
 Microelectronics  
 Nuclear Power  
 Offshore oil exploration  
 Oil & gas  
 Pharmaceuticals  
 Power generation  
 Pulp & paper  
 Steel  
 Water/wastewater

### Key Products

Analytical Instruments  
 Analytical sample conditioning products & systems  
 Chemical injection fittings & valves  
 Fluoropolymer chemical delivery fittings, valves & pumps  
 High purity gas delivery fittings, valves, regulators & digital flow controllers  
 Industrial mass flow meters/controllers  
 Permanent no-weld tube fittings  
 Precision industrial regulators & flow controllers  
 Process control double block & bleeds  
 Process control fittings, valves, regulators & manifold valves



## Sealing & Shielding

### Key Markets

Aerospace  
 Chemical processing  
 Consumer  
 Fluid power  
 General industrial  
 Information technology  
 Life sciences  
 Microelectronics  
 Military  
 Oil & gas  
 Power generation  
 Renewable energy  
 Telecommunications  
 Transportation

### Key Products

Dynamic seals  
 Elastomeric o-rings  
 Electro-medical instrument design & assembly  
 EMI shielding  
 Extruded & precision-cut, fabricated elastomeric seals  
 High temperature metal seals  
 Homogeneous & inserted elastomeric shapes  
 Medical device fabrication & assembly  
 Metal & plastic retained composite seals  
 Shielded optical windows  
 Silicone tubing & extrusions  
 Thermal management  
 Vibration dampening

ENGINEERING YOUR SUCCESS.

Parker Hannifin Corporation  
**Fluid and Climate Controls Europe**  
Via Enrico Fermi,5  
20060 Gessate - Milano - Italy  
phone +39 (0) 2 95125.1  
[www.parker.com](http://www.parker.com)

Catalogue 0112/UK 07/2025

Your Local Authorized Parker Distributor

© 2025 Parker Hannifin Corporation

