



# AIR PREPARATION SYSTEM STAINLESS STEEL FRLS

1/4 & 1/2 Body Ports



**WARNING – USER RESPONSIBILITY****FAILURE OR IMPROPER SELECTION OR IMPROPER USE OF THE PRODUCTS DESCRIBED HEREIN OR RELATED ITEMS CAN CAUSE DEATH, PERSONAL INJURY AND PROPERTY DAMAGE.**

- This document and other information from Parker-Hannifin Corporation, its subsidiaries and authorized distributors provide product or system options for further investigation by users having technical expertise.
- The user, through its own analysis and testing, is solely responsible for making the final selection of the system and components and assuring that all performance, endurance, maintenance, safety and warning requirements of the application are met. The user must analyze all aspects of the application, follow applicable industry standards, and follow the information concerning the product in the current product catalog and in any other materials provided from Parker or its subsidiaries or authorized distributors.
- To the extent that Parker or its subsidiaries or authorized distributors provide component or system options based upon data or specifications provided by the user, the user is responsible for determining that such data and specifications are suitable and sufficient for all applications and reasonably foreseeable uses of the components or systems.

**Offer of Sale**

Please contact your Parker representation for a detailed "Offer of Sale".

## Table of Contents

PF504 Filter – Miniature .....	4
PF501 Coalescing Filter – Miniature .....	6
PR354, PR364 Regulator – Miniature .....	8
PB548, PB558 Filter / Regulator – Miniature .....	10
PF10 Filter – Standard .....	12
PF11 Coalescing Filter – Standard .....	14
PR10, PR11 Regulator – Standard .....	16
PB11, PB12 Filter / Regulator – Standard .....	18
PL10 Lubricator – Standard.....	20



If you have questions about the products contained in this catalog, or their applications, please contact:  
**Parker Hannifin EMEA Sàrl European Headquarters**  
[parker.com/msgc](http://parker.com/msgc)

# PF504 FILTER – MINIATURE

## 1/4 Inch Ports

- Stainless steel construction handles most corrosive environments
- Fluorocarbon seals standard
- Meets NACE specifications MR-01-75/ISO 15156
- High flow: 1/4" - 10.85 dm<sup>3</sup>/s<sup>§</sup>
- 1/8" female threaded drain



### Symbols

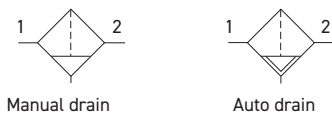

### Options

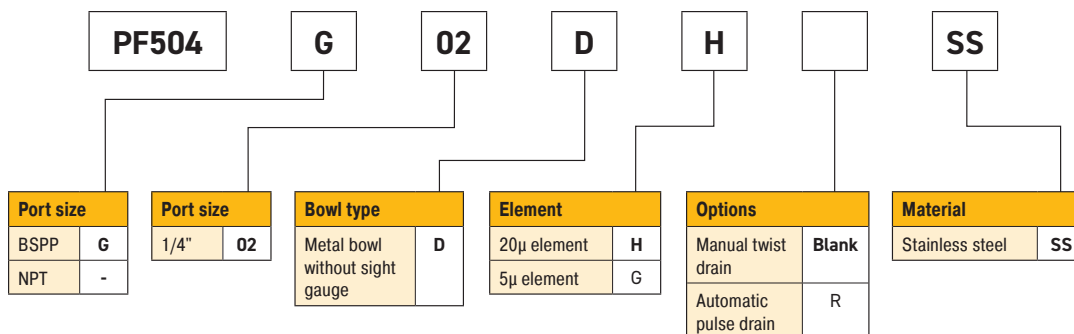

Note: Bold options are most popular

Port size	Description	Order code	Max bar	Height mm	Width mm	Depth mm
G1/4	BSPG Manual twist drain	<b>PF504G02DHSS</b>	20.7	102	40	40
1/4	NPT Manual twist drain	<b>PF504-02DHSS</b>	20.7	102	40	40
G1/4	BSPG Automatic pulse drain	<b>PF504G02DHRSS</b>	12.0	102	40	40
1/4	NPT Automatic pulse drain	<b>PF504-02DHRSS</b>	12.0	102	40	40

§ dm<sup>3</sup>/s = Flow at 6.2 bar and a 0.3 bar pressure drop

Specifications		
Bowl capacity	29 cm <sup>3</sup>	
Filter rating	20 micron	
Sump capacity	12 cm <sup>3</sup>	
Port threads	1/4	
Operating temperature	Manual twist drain	-18°C to 82°C
	Automatic pulse drain	0°C to 66°C
Max supply pressure	Manual twist drain	0 to 20.7 bar
	Automatic pulse drain	0 to 12 bar
Weight	274 g	

**Note:** Air must be dry enough to avoid ice formation at temperatures below 2°C.

Materials of Construction	
Body	316 Stainless steel
Bowl	316 Stainless steel
Deflector	Acetal
Drain	316 Stainless steel
Element holder	Acetal
Filter element	Polyethylene
Seals	Fluorocarbon

## Dimensions (mm)

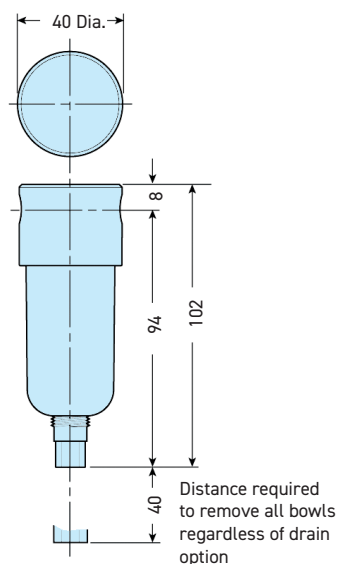

## Flow Charts

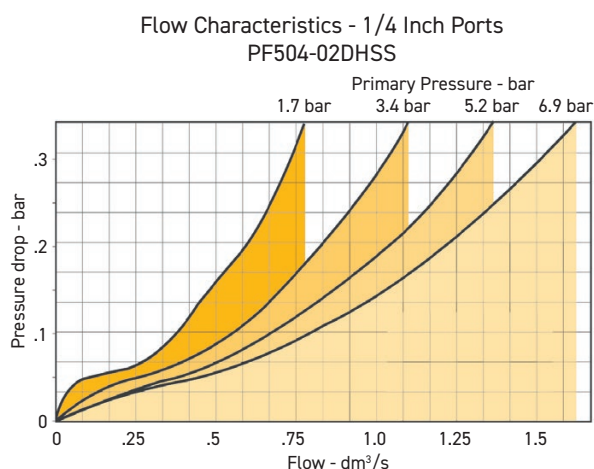

Accessories		
Filter element kits	Particulate (5 micron)	<b>EK504VY</b>
	Particulate (20 micron)	<b>EK504Y</b>
Drain kits	Automatic pulse drain	<b>RK504SY-SS</b>
Manual twist drain	Small (Old)	<b>SA600Y7-1SS</b>
	Large (New)	<b>SAP05481</b>
Pipe nipple	1/4" NPT 316 Stainless Steel	<b>616Y28-SS</b>
	1/4" BSP 316 Stainless Steel	<b>AC-2SS</b>

## Operation

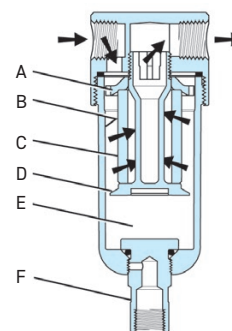

### First Stage Filtration:

Air enters at inlet port and flows through deflector plate (A) which causes a swirling action. Liquids and coarse particles are forced to the bowl interior wall (B) by the centrifugal action of the swirling air. They are then carried down the bowl wall by the force of gravity. The baffle (D) separates the lower portion of the bowl into a "quiet zone" (E) where the removed liquid and particles collect, unaffected by the swirling air, and are therefore not reentrained into the flowing air.

### Second Stage Filtration:

After liquids and large particles are removed in the first stages of filtration, the air flows through element (C) where smaller particles are filtered out. The filtered air then passes downstream. Collected liquids and particles in the "quiet zone" (E) should be drained before their level reaches a height where they would be reentrained in the flowing air. This can be accomplished by unscrewing the drain valve (F) slightly until the liquid begins to drain.

# PF501 COALESCING FILTER – MINIATURE

## 1/4 Inch Ports

- Stainless steel construction handles most corrosive environments
- Meets NACE specifications MR-01-75/ISO 15156
- High flow: 1/4" - 7,55 dm<sup>3</sup>/s<sup>§</sup>
- 1/8" female threaded drain



### Symbols



### Options

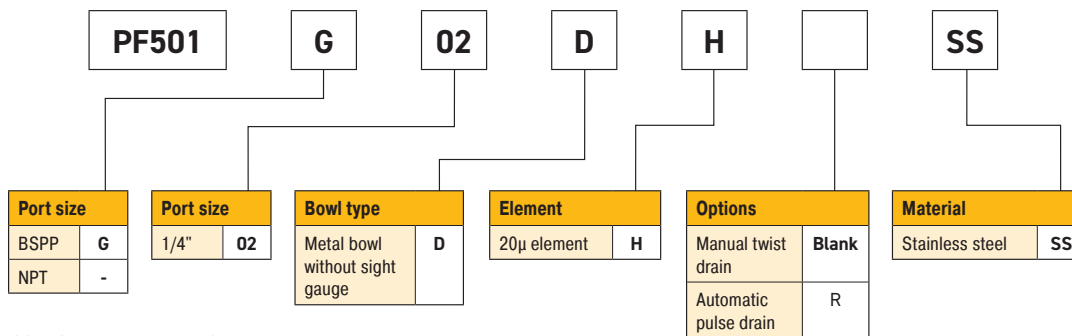

**Note:** Bold options are most popular

Port size	Description	Order code	Max bar	Height mm	Width mm	Depth mm
G1/4	BSPP Manual twist drain	<b>PF501G02DHSS</b>	20.7	102	40	40
1/4	NPT Manual twist drain	<b>PF501-02DHSS</b>	20.7	102	40	40
G1/4	BSPP Automatic pulse drain	<b>PF501G02DHRSS</b>	12.0	102	40	40
1/4	NPT Automatic pulse drain	<b>PF501-02DHRSS</b>	12.0	102	40	40

<sup>§</sup> dm<sup>3</sup>/s = Flow at 6.2 bar and a 0.3 bar pressure drop

Specifications		
Bowl capacity	29 cm <sup>3</sup>	
Filter rating	0.3 micron	
Sump capacity	12 cm <sup>3</sup>	
Port threads	1/4	
Operating temperature	Manual twist drain	-18°C to 82°C
	Automatic pulse drain	0°C to 66°C
Max supply pressure	Manual twist drain	0 to 20.7 bar
	Automatic pulse drain	0 to 12 bar
Weight	275 g	

**Note:** Air must be dry enough to avoid ice formation at temperatures below 2°C.

## Flow Charts

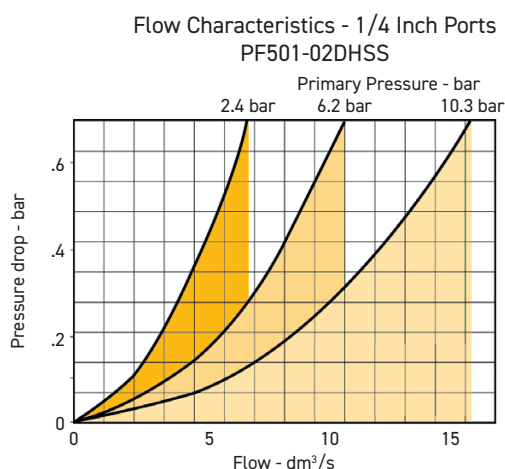

Materials of Construction	
Body	316 Stainless steel
Bowl	316 Stainless steel
Drain	316 Stainless steel
Element holder	Acetal
Filter element	Borosilicate Fiber
Seals	Flourocarbon

Accessories		
Filter element kits	0.3 micron	<b>EKF501H</b>
Drain kits	Automatic pulse drain	<b>RK504SY-SS</b>
Manual twist drain	Small (Old)	<b>SA600Y7-1SS</b>
	Large (New)	<b>SAP05481</b>
Pipe nipple	1/4" NPT 316 Stainless Steel	<b>616Y28-SS</b>
	1/4" BSP 316 Stainless Steel	<b>AC-2SS</b>

## Dimensions (mm)

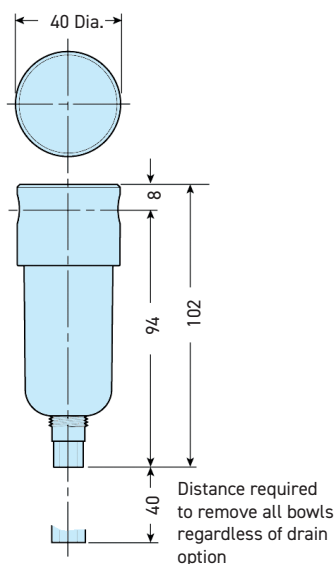

## Operation

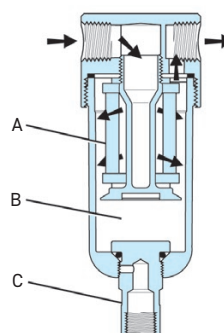

The contaminated air enters the element interior and is forced through a thick membrane (A) of "borosilicate" glass fibers coated with epoxy. Flow then passes through the element, and at this stage 99.97% of the sub-micronic particles have been removed from the air stream. The tiny droplets coalesce together and are collected from the filter element by the outer drain layer.

The clean, filtered air now passes through and out into the pneumatic system. The air line coalescing filter removes liquid aerosols and sub-micron particulate matter.

Collected liquids and particles in the "quiet zone" (B) should be drained before their level reaches a height where they would be reentrained in the flowing air. This can be accomplished by unscrewing the drain valve (C) slightly until the liquid begins to drain.

# PR354, PR364 REGULATOR – MINIATURE

## 1/4 Inch Ports

- Stainless steel construction handles most corrosive environments
- Large diaphragm to valve area ratio for precise regulation and high flow capacity
- Meets NACE specifications MR-01-75/ISO 15156
- High flow: 1/4" – 5.75 dm<sup>3</sup>/s<sup>§</sup>



PR364

PR354

### Symbols

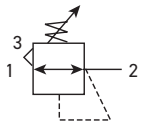

### Options

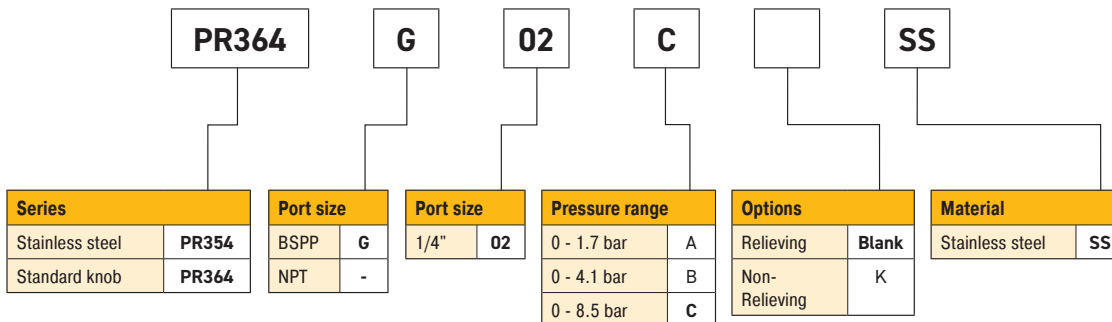

Note: Bold options are most popular

Port size	Series	Description	Order code	Max bar	Height mm	Width mm	Depth mm
G1/4	PR364	BSPP - Standard knob	<b>PR364G02CSS</b>	20.7	78	40	40
1/4	PR364	NPT - Standard knob	<b>PR364-02CSS</b>	20.7	78	40	40
G1/4	PR354	BSPP - All metal	<b>PR354G02CSS</b>	20.7	64	40	40
1/4	PR354	NPT - All metal	<b>PR354-02CSS</b>	20.7	64	40	40

<sup>§</sup> dm<sup>3</sup>/s = 7 bar inlet pressure with 5.5 bar set pressure and 1 bar pressure drop.

**⚠ Warning**

Product rupture can cause serious injury.  
Do not connect regulator to bottled gas.  
Do not exceed maximum primary pressure rating.

Specifications		
Gauge port	1/4	
Operation	Flourocarbon diaphragm	
Port threads	1/4	
Operating temperature	PR354	-18°C to 82°C
	PR364	-18°C to 66°C
Max supply pressure	PR354	0 to 20.7 bar
	PR364	0 to 20.7 bar
Weight	230 g	

**Note:** Air must be dry enough to avoid ice formation at temperatures below 2°C.

Materials of Construction	
Adjustment mechanism / Springs	316 Stainless steel
Adjustment knob (PR354)	316 Stainless steel
Adjustment knob (PR364)	Polypropylene
Body	316 Stainless steel
Bonnet (PR354)	316 Stainless steel
Bonnet (PR364)	Acetal
Bottom plug	316 Stainless steel
Poppet	316 Stainless steel
Seals	Flourocarbon

### Dimensions (mm)

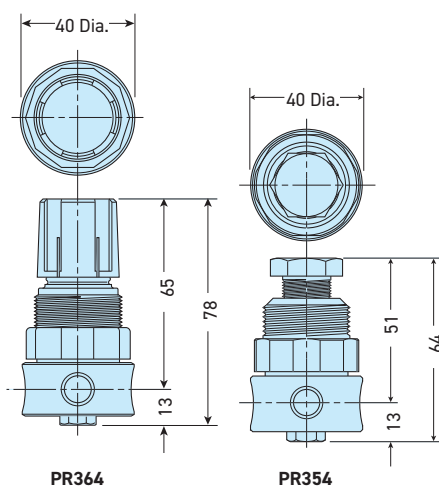

**Note:** 32mm dia. hole required for panel mounting.

Catalog PDE2504TCUK - Stainless Steel FRLs

### Flow Charts

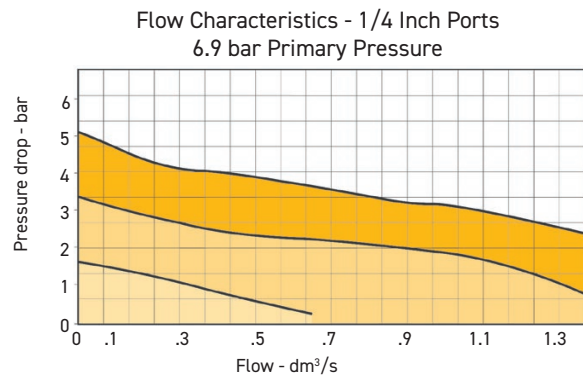

#### CAUTION: REGULATOR PRESSURE ADJUSTMENT

The working range of knob adjustment is designed to permit outlet pressures within their full range. Pressure adjustment beyond this range is also possible because the knob is not a limiting device. This is a common characteristic of most industrial regulators, and limiting devices may be obtained only by special design. For best performance, regulated pressure should always be set by increasing the pressure up to the desired setting.

Accessories		
R354 Bonnet Kit	0.3 micron	<b>CKR354YSS</b>
R364 Bonnet Kit	Knob included	<b>CKR364YSS</b>
Gauge - 0 to 10 bar	BSPP	<b>M1/4G40S-10</b>
	NPT	<b>K4520N14160SS</b>
Panel Mount Bracket (Stainless)		<b>161X57-SS</b>
Panel Mount Nut	Stainless	<b>R05X51 SS</b>
	Plastic	<b>R05X51-P</b>
Pipe Nipple	1/4" NPT 316 Stainless Steel	<b>616Y28-SS</b>
	1/4" BSPT 316 Stainless Steel	<b>AC-2SS</b>
Service Kit	Relieving	<b>RKR364YSS</b>
	Non-Relieving	<b>RKR364KYSS</b>

### Operation

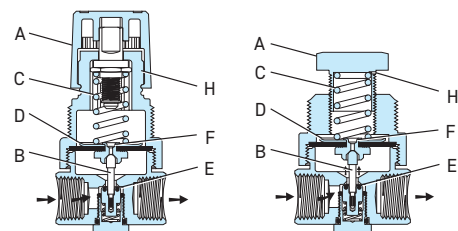

With the adjusting knob (A) turned fully counter-clockwise (no spring load), and pressure supplied to the regulator inlet port, the valve poppet assembly (B) is closed. Turning the adjusting knob clockwise applies a load to control spring (C). This load causes the diaphragm (D) and the valve poppet assembly (B) to move downward allowing flow across the seat area (E) created between the poppet assembly and the seat. Pressure in the downstream line is sensed below the diaphragm (D) and offsets the load of spring (C). As downstream pressure rises, poppet assembly (B) and diaphragm (D) move upward until the area (E) is closed and the load of the spring (C) and pressure under diaphragm (D) are in balance. A reduced outlet pressure has now been obtained, depending on spring load. Creating a demand downstream, such as opening a valve, results in a reduced pressure under the diaphragm (D). The load of control spring (C) now causes the poppet assembly to move downward opening seat area (E) allowing air to flow to meet the downstream demand. The flow of downstream air is metered by the amount of opening (E). Should downstream pressure exceed the desired regulated pressure, the excess pressure will cause the diaphragm (D) to move upward against control spring (C), open vent hole (F), and vent the excess pressure to atmosphere through the hole in the bonnet (H). (This occurs in the relieving type regulator only.)

Electric Motion and Pneumatic Division - Europe

# PB548, PB558 FILTER / REGULATOR – MINIATURE

## 1/4 Inch Ports

- Stainless steel construction handles most corrosive environments
- Large diaphragm to valve area ratio for precise regulation and high flow capacity
- Meets NACE specifications MR-01-75/ISO 15156.
- High flow: 1/4" – 5.75 dm<sup>3</sup>/s<sup>§</sup>
- 1/8" female threaded drain

### Symbols

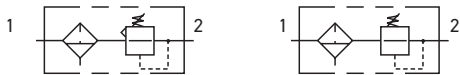

### Options

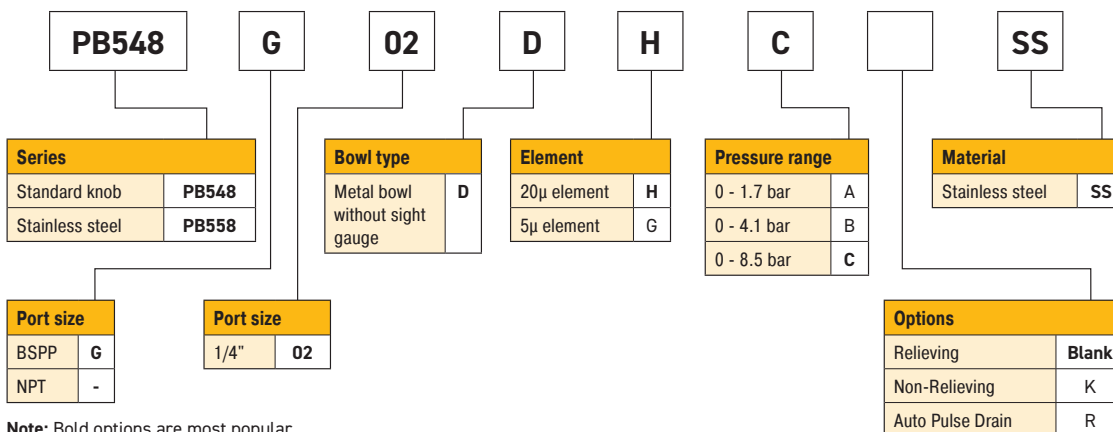

Note: Bold options are most popular

Port size	Series	Description	Order code	Max bar	Height mm	Width mm	Depth mm
G1/4	PB548	BSP - Standard knob - Manual drain	<b>PB548G02DHCSS</b>	20.7	147	40	40
G1/4	PB548	BSP - Standard knob - Auto drain	<b>PB548G02DHCSS</b>	12.0	147	40	40
1/4	PB548	NPT - Standard knob - Manual drain	<b>PB548-02DHCSS</b>	20.7	147	40	40
1/4	PB548	NPT - Standard knob - Auto drain	<b>PB548-02DHCSS</b>	12.0	147	40	40
G1/4	PB558	BSP - All metal - Manual drain	<b>PB558G02DHCSS</b>	20.7	78	40	40
G1/4	PB558	BSP - All metal - Auto drain	<b>PB558G02DHCSS</b>	12.0	78	40	40
1/4	PB558	NPT - All metal - Manual drain	<b>PB558-02DHCSS</b>	20.7	78	40	40
1/4	PB558	NPT - All metal - Auto drain	<b>PB558-02DHCSS</b>	12.0	78	40	40

§ dm<sup>3</sup>/s = 7 bar inlet pressure with 5.5 bar set pressure and 1 bar pressure drop.

**Warning**

Product rupture can cause serious injury.  
Do not connect regulator to bottled gas.  
Do not exceed maximum primary pressure rating.

Specifications		
Bowl capacity	29 cm <sup>3</sup>	
Filter rating	20 micron	
Gauge port	1/4	
Operation	Fluorocarbon diaphragm	
Port threads	1/4	
Operating temperature	PB548	-18°C to 82°C
	PB558	-18°C to 66°C
	Auto Pulse Drain	0°C to 66°C
Max supply pressure	PB548	0 to 20.7 bar
	PB558	0 to 20.7 bar
	Auto Pulse Drain	0 to 12 bar
Sump capacity	12 cm <sup>3</sup>	
Weight	270 g	

**Note:** Air must be dry enough to avoid ice formation at temperatures below 2°C.

Materials of Construction	
Adjustment mechanism / Springs	316 Stainless steel
Adjustment knob (PR364)	Polypropylene
Body	316 Stainless steel
Bonnet (PB548)	Acetal
Bonnet (PB558)	316 Stainless Steel
Bottom plug	316 Stainless steel
Poppet	316 Stainless steel

## Dimensions (mm)

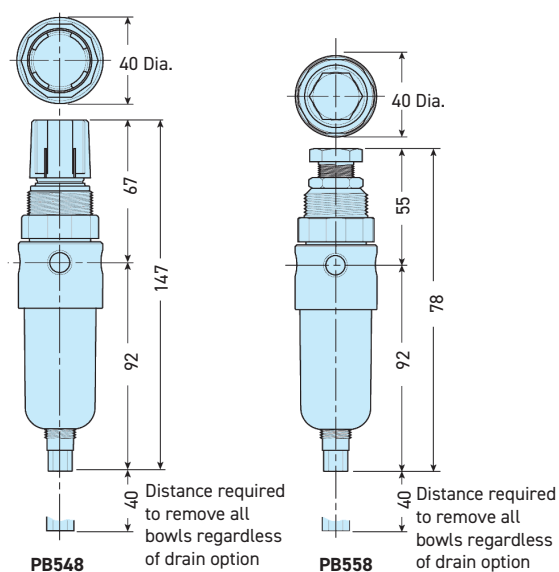

**Note:** 32mm dia. hole required for panel mounting.

Catalog PDE2504TCUK - Stainless Steel FRLs

## Flow Charts

Flow Characteristics - 1/4 Inch Ports  
6.9 bar Primary Pressure

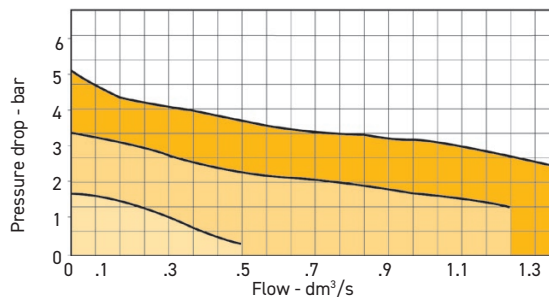

### CAUTION: REGULATOR PRESSURE ADJUSTMENT

The working range of knob adjustment is designed to permit outlet pressures within their full range. Pressure adjustment beyond this range is also possible because the knob is not a limiting device. This is a common characteristic of most industrial regulators, and limiting devices may be obtained only by special design. For best performance, regulated pressure should always be set by increasing the pressure up to the desired setting.

Accessories		
Filter Element Kits	Particulate (5 micron)	<b>EK504VY</b>
	Particulate (20 micron)	<b>EK504Y</b>
Gauge - 0 to 10 bar	BSPP	<b>M1/4G40S-10</b>
	NPT	<b>K4520N14160SS</b>
Drain Kits	Automatic Pulse Drain	<b>RK504SY-SS</b>
Manual Twist Drain	Small (Old)	<b>SA600Y7-1SS</b>
	Large (New)	<b>SAP05481</b>
Panel Mount Bracket (Stainless)		<b>161X57-SS</b>
Panel Mount Nut	Stainless	<b>R05X51SS</b>
	Plastic	<b>R05X51-P</b>
Pipe Nipple	1/4" NPT 316 Stainless Steel	<b>616Y28-SS</b>
	1/4" BSP 316 Stainless Steel	<b>AC-2SS</b>
Service Kit	Relieving	<b>RK549YSS</b>
	Non-Relieving	<b>RK548YSS</b>

## Operation

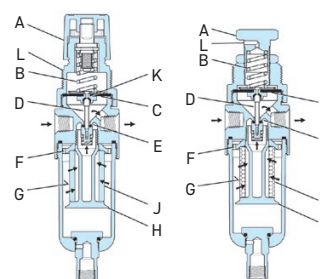

Turning the adjusting knob clockwise applies a load to control spring (B) which forces diaphragm (C) and valve poppet assembly (D) to move downward allowing filtered air to flow through the seat area (E) created between the poppet assembly and the seat. "First stage filtration". Air pressure supplied to the inlet port is directed through deflector plate (F) causing a swirling centrifugal action forcing liquids and coarse particles to the inner bowl wall (G) and down below the lower baffle (H) to the quiet zone. After liquids and large particles are removed in the first stage of filtration "second stage filtration" occurs as air flows through element (J) where smaller particles are filtered out and retained. The air flow now passes through seat area (E) to the outlet port of the unit. Pressure in the downstream line is sensed below the diaphragm (C) and offsets the load of spring (B). When downstream pressure reaches the set-point, poppet valve assembly (D) and diaphragm (C) move upward closing seat area (E). Should downstream pressure exceed the desired regulated pressure, the excess pressure will cause the diaphragm (C) to move upward opening vent hole (K) venting the excess pressure to atmosphere through the hole in the bonnet (L). (This occurs in the standard relieving type filter/regulators only.)

Electric Motion and Pneumatic Division - Europe

# PF10 FILTER – STANDARD

## 1/2 Inch Ports

- Stainless steel construction handles most corrosive environments
- Meets NACE specifications MR-01-75/ISO 15156
- High flow: 1/2" - 34 dm<sup>3</sup>/s<sup>§</sup>
- 1/8" female threaded drain



### Symbols

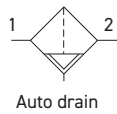
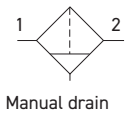

### Options

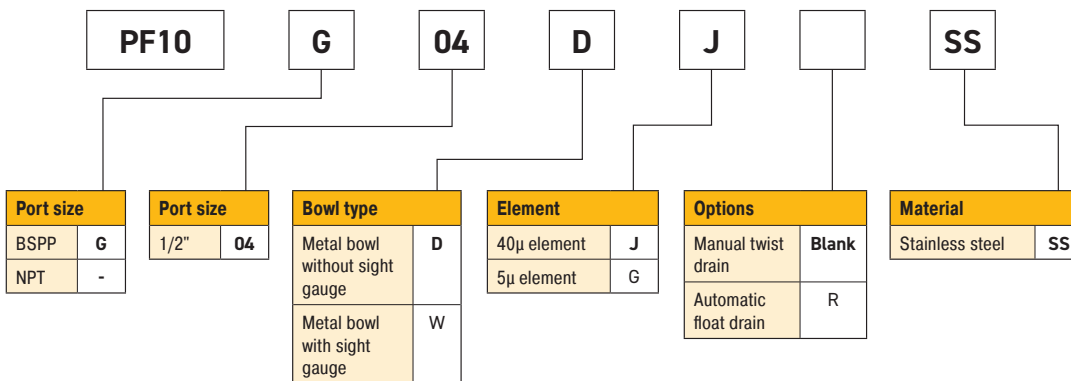

**Note:** Bold options are most popular

Port size	Description	Order code	Max bar	Height mm	Width mm	Depth mm
G1/2	BSPP Manual twist drain - Metal bowl - Without sight gauge	<b>PF10G04DJSS</b>	20.7	141	64	60
1/2	NPT Manual twist drain - Metal bowl - Without sight gauge	<b>PF10-04DJSS</b>	20.7	141	64	60
G1/2	BSPP Manual twist drain - Metal bowl - With sight gauge	<b>PF10G04WJSS</b>	17.2	141	64	60
1/2	NPT Manual twist drain - Metal bowl - With sight gauge	<b>PF10-04WJSS</b>	17.2	141	64	60
G1/2	BSPP Automatic pulse drain - Metal bowl - Without sight gauge	<b>PF10G04JRSS</b>	12.0	141	64	60
1/2	NPT Automatic pulse drain - Metal bowl - Without sight gauge	<b>PF10-04JRSS</b>	12.0	141	64	60
G1/2	BSPP Automatic pulse drain - Metal bowl - With sight gauge	<b>PF10G04WJRSS</b>	12.0	141	64	60
1/2	NPT Automatic pulse drain - Metal bowl - With sight gauge	<b>PF10-04WJRSS</b>	12.0	141	64	60

<sup>§</sup> dm<sup>3</sup>/s = Flow at 6.2 bar and a 0.3 bar pressure drop

Specifications		
Bowl capacity	118 cm <sup>3</sup>	
Filter rating	40 micron	
Sump capacity	50 cm <sup>3</sup>	
Port threads	1/2	
Operating temperature	Manual twist drain (D)	-18°C to 82°C
	Manual twist drain (W)	-18°C to 66°C
	Automatic pulse drain	0°C to 66°C
Max supply pressure	Manual twist drain (D)	0 to 20.7 bar
	Manual twist drain (W)	0 to 17.2 bar
	Automatic pulse drain	0 to 12 bar
Weight	850 g	

**Note:** Air must be dry enough to avoid ice formation at temperatures below 2°C.

Materials of Construction	
Body	316 Stainless steel
Bowl	316 Stainless steel
Deflector	Acetal
Drain	316 Stainless steel
Element holder	Acetal
Filter element	Polyethylene
Seals	Flouorocarbon
Sight gauge	Isoplast

## Dimensions (mm)

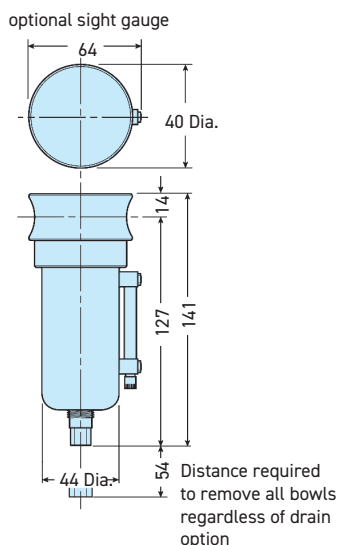

## Flow Charts

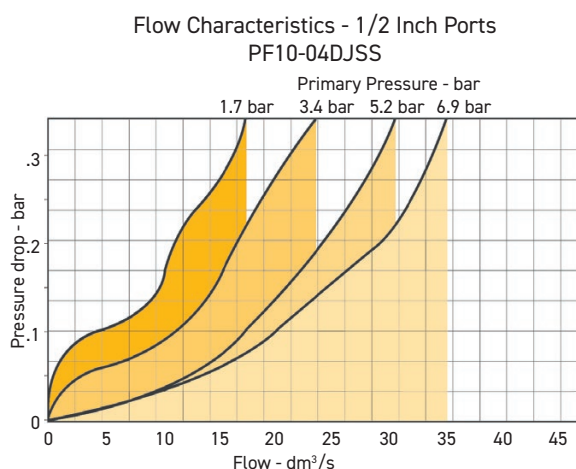

Accessories		
Filter element kits	Particulate (40 micron)	<b>EK55J</b>
	Particulate (5 micron)	<b>EK55G</b>
Drain kits	Automatic float drain	<b>SA10MDSS</b>
Manual twist drain	Small (Old)	<b>SA600Y7-1SS</b>
	Large (New)	<b>SAP05481</b>
Pipe nipple	1/2" NPT 316 Stainless Steel	<b>616A28-SS</b>
	1/2" BSP 316 Stainless Steel	<b>AC-4SS</b>

## Operation

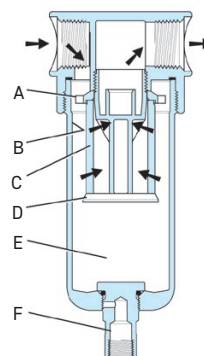

### First Stage Filtration:

Air enters at inlet port and flows through deflector plate (A) which causes a swirling action. Liquids and coarse particles are forced to the bowl interior wall (B) by the centrifugal action of the swirling air. They are then carried down the bowl wall by the force of gravity. The baffle (D) separates the lower portion of the bowl into a "quiet zone" (E) where the removed liquid and particles collect, unaffected by the swirling air, and are therefore not reentrained into the flowing air.

### Second Stage Filtration:

After liquids and large particles are removed in the first stages of filtration, the air flows through element (C) where smaller particles are filtered out. The filtered air then passes downstream. Collected liquids and particles in the "quiet zone" (E) should be drained before their level reaches a height where they would be reentrained in the flowing air. This can be accomplished by unscrewing the drain valve (F) slightly until the liquid begins to drain.

# PF11 COALESCING FILTER – STANDARD

## 1/2 Inch Ports

- Stainless steel construction handles most corrosive environments
- Meets NACE specifications MR-01-75/ISO 15156
- High flow: 1/2" - 21 dm<sup>3</sup>/s<sup>§</sup>
- 1/8" female threaded drain
- High efficiency 0.01µm filtration
- Removes liquid aerosols and sub micron particles



### Symbols

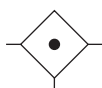

### Options

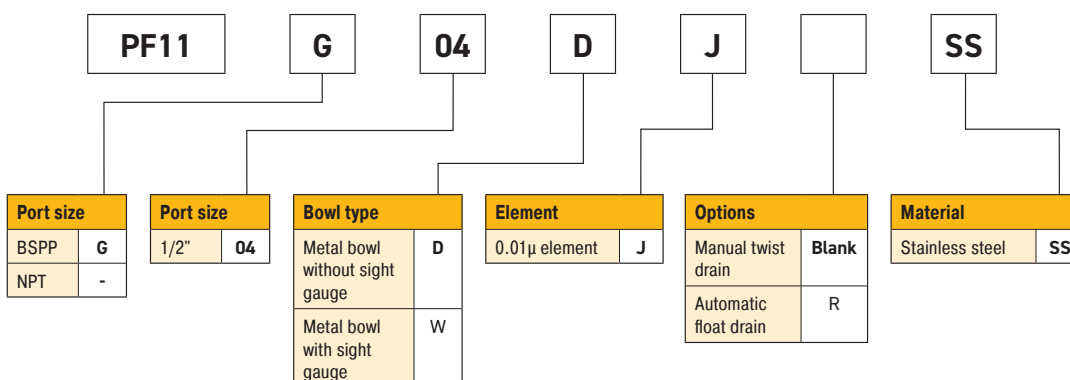

**Note:** Bold options are most popular

Port size	Description	Order code	Max bar	Height mm	Width mm	Depth mm
G1/2	BSPG Manual twist drain - Metal bowl - Without sight gauge	<b>PF11G04DJSS</b>	20.7	141	64	60
1/2	NPT Manual twist drain - Metal bowl - Without sight gauge	<b>PF11-04DJSS</b>	20.7	141	64	60
G1/2	BSPG Manual twist drain - Metal bowl - With sight gauge	<b>PF11G04WJSS</b>	17.2	141	64	60
1/2	NPT Manual twist drain - Metal bowl - With sight gauge	<b>PF11-04WJSS</b>	17.2	141	64	60
G1/2	BSPG Automatic pulse drain - Metal bowl - Without sight gauge	<b>PF11G04DJRSS</b>	12.0	141	64	60
1/2	NPT Automatic pulse drain - Metal bowl - Without sight gauge	<b>PF11-04DJRSS</b>	12.0	141	64	60
G1/2	BSPG Automatic pulse drain - Metal bowl - With sight gauge	<b>PF11G04WJRSS</b>	12.0	141	64	60
1/2	NPT Automatic pulse drain - Metal bowl - With sight gauge	<b>PF11-04WJRSS</b>	12.0	141	64	60

<sup>§</sup> dm<sup>3</sup>/s = Flow at 6.2 bar and a 0.3 bar pressure drop

Specifications		
Bowl capacity	118 cm <sup>3</sup>	
Filter rating	0.01 micron	
Sump capacity	50 cm <sup>3</sup>	
Port threads	1/2	
Operating temperature	Manual twist drain (D)	-18°C to 82°C
	Manual twist drain (W)	-18°C to 66°C
	Automatic pulse drain	0°C to 66°C
Max supply pressure	Manual twist drain (D)	0 to 20.7 bar
	Manual twist drain (W)	0 to 17.2 bar
	Automatic pulse drain	0 to 12 bar
Weight	850 g	

**Note:** Air must be dry enough to avoid ice formation at temperatures below 2°C.

Materials of Construction	
Body	316 Stainless steel
Bowl	316 Stainless steel
Drain	316 Stainless steel
Element holder	Acetal
Filter element	Borosilicate Fiber
Seals	Flourocarbon
Sight gauge	Isoplast

## Dimensions (mm)

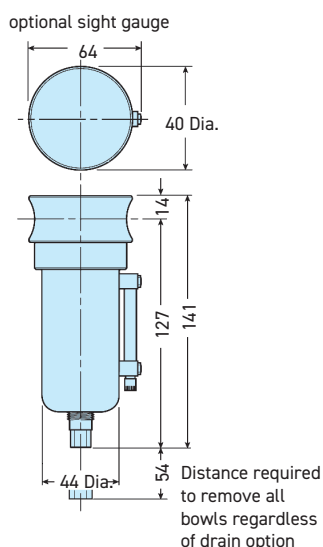

## Flow Charts

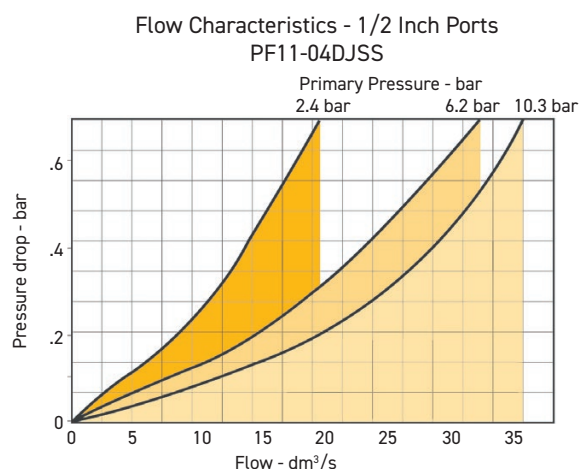

Accessories		
Filter element kits	Particulate (0.01 micron)	<b>EKF71</b>
Drain kits	Automatic float drain	<b>SA10MDSS</b>
Manual twist drain	Small (Old)	<b>SA600Y7-1SS</b>
	Large (New)	<b>SAP05481</b>
Pipe nipple	1/2" NPT 316 Stainless Steel	<b>616A28-SS</b>
	1/2" BSP 316 Stainless Steel	<b>AC-4SS</b>

## Operation

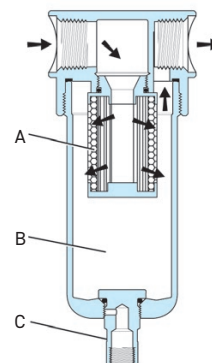

The contaminated air enters the element interior and is forced through a thick membrane (A) of "borosilicate" glass fibers coated with epoxy. Flow then passes through the element, and at this stage 99.97% of the sub-micronic particles have been removed from the air stream. The tiny droplets coalesce together and are collected from the filter element by the outer drain layer.

The clean, filtered air now passes through and out into the pneumatic system. The air line coalescing filter removes liquid aerosols and sub-micron particulate matter.

Collected liquids and particles in the "quiet zone" (B) should be drained before their level reaches a height where they would be reentrained in the flowing air. This can be accomplished by unscrewing the drain valve (C) slightly until the liquid begins to drain.

# PR10, PR11 REGULATOR – STANDARD

## 1/2 Inch Ports

- Stainless steel construction handles most corrosive environments
- Large diaphragm to valve area ratio for precise regulation and high flow capacity
- Meets NACE specifications MR-01-75/ISO 15156
- Low temperature version available
- High flow: 1/2" – 37.75 dm<sup>3</sup>/s<sup>§</sup>



### Symbols

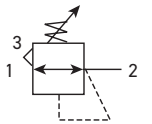

### Options

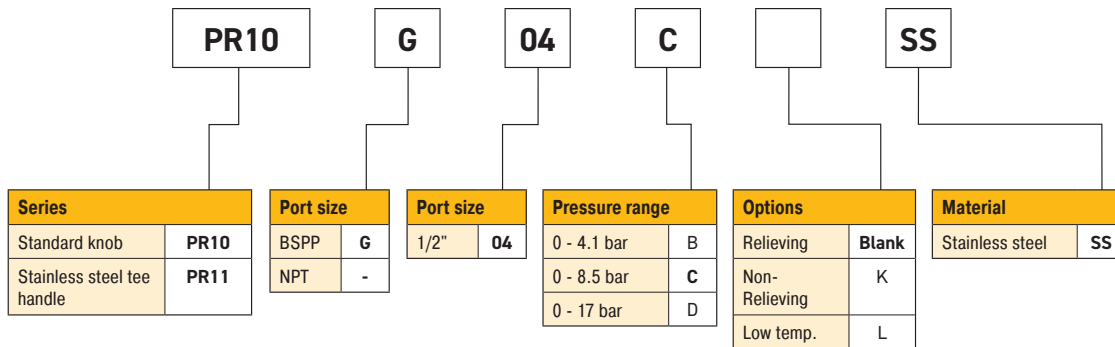

Note: Bold options are most popular

Port size	Series	Description	Order code	Max bar	Height mm	Width mm	Depth mm
G1/2	PR10	BSPP - Standard knob	<b>PR10G04CSS</b>	20.7	126	62	60
1/2	PR10	NPT - Standard knob	<b>PR10-04CSS</b>	20.7	126	62	60
G1/2	PR11	BSPP - Stainless steel tee handle	<b>PR11G04CSS</b>	20.7	154	62	60
1/2	PR11	NPT - Stainless steel tee handle	<b>PR11-04CSS</b>	20.7	154	62	60

§ dm<sup>3</sup>/s = 7 bar inlet pressure with 5.5 bar set pressure and 1 bar pressure drop.

**Warning**

Product rupture can cause serious injury.  
Do not connect regulator to bottled gas.  
Do not exceed maximum primary pressure rating.

Specifications		
Gauge port	1/4	
Operation	Flourocarbon diaphragm	
Port threads	1/2	
Operating temperature	PR10	-18°C to 66°C
	PR11	-18°C to 82°C
Option "L" minimum operating temperature	-40°C	
Max supply pressure	PR10	0 to 20.7 bar
	PR11	0 to 20.7 bar
Weight	810 g	

**Note:** Air must be dry enough to avoid ice formation at temperatures below 2°C.

**Note:** "Low Temperature" option is intended for applications where the ambient temperature may be down to -40° C/F. Air supply must be free of moisture to prevent ice formation and malfunction of units. These units contain EPDM seals. Make sure any oils in the airstream are compatible.

Materials of Construction	
Adjustment mechanism / Springs	316 Stainless steel
Body	316 Stainless steel
Bonnet / Tee handle (PR11)	316 Stainless steel
Bonnet / Knob (PR10)	Acetal
Bottom plug	316 Stainless steel
Poppet	316 Stainless steel
Seals	Flourocarbon

## Dimensions (mm)

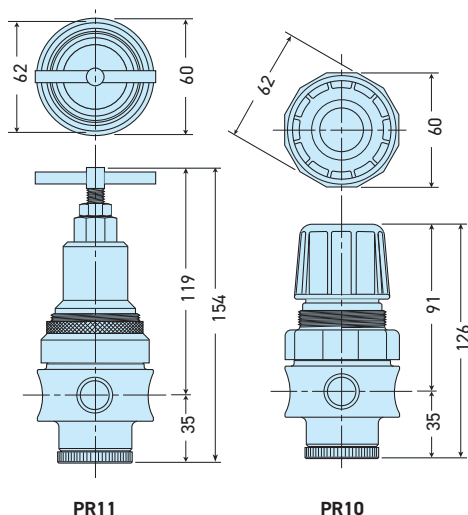

**Note:** 44mm dia. hole required for panel mounting.

Catalog PDE2504TCUK - Stainless Steel FRLs

## Flow Charts

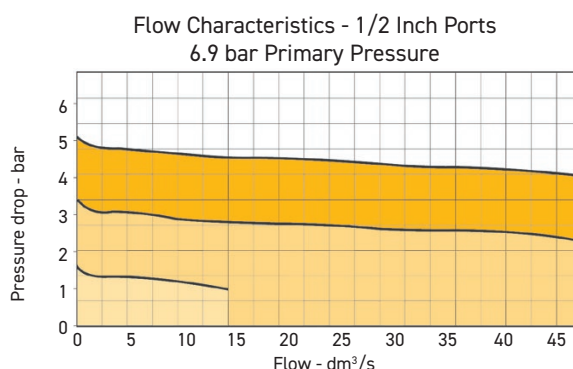

### CAUTION: REGULATOR PRESSURE ADJUSTMENT

The working range of knob adjustment is designed to permit outlet pressures within their full range. Pressure adjustment beyond this range is also possible because the knob is not a limiting device. This is a common characteristic of most industrial regulators, and limiting devices may be obtained only by special design. For best performance, regulated pressure should always be set by increasing the pressure up to the desired setting.

Accessories		
R10 Bonnet Kit	Knob included	<b>CKR10YSS</b>
R11 Bonnet Kit		<b>CKR11YSS</b>
Gauge - 0 to 10 bar	BSPP	<b>M1/4G40S-10</b>
	NPT	<b>K4520N14160SS</b>
Panel Mount Bracket (Stainless)		<b>R10Y57-SS</b>
Panel Mount Nut	Stainless	<b>R10X51SS</b>
	Plastic	<b>R10X51-P</b>
Pipe Nipple	1/2" NPT 316 Stainless Steel	<b>616A28-SS</b>
	1/2" BSPT 316 Stainless Steel	<b>AC-4SS</b>
Service Kit	Relieving	<b>RKR10YSS</b>
	Non-Relieving	<b>RKR10KYSS</b>

## Operation

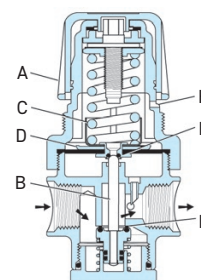

With the adjusting knob (A) turned fully counter-clockwise (no spring load), and pressure supplied to the regulator inlet port, the valve poppet assembly (B) is closed. Turning the adjusting knob clockwise applies a load to control spring (C). This load causes the diaphragm (D) and the valve poppet assembly (B) to move downward allowing flow across the seat area (E) created between the poppet assembly and the seat. Pressure in the downstream line is sensed below the diaphragm (D) and offsets the load of spring (C). As downstream pressure rises, poppet assembly (B) and diaphragm (D) move upward until the area (E) is closed and the load of the spring (C) and pressure under diaphragm (D) are in balance. A reduced outlet pressure has now been obtained, depending on spring load. Creating a demand downstream, such as opening a valve, results in a reduced pressure under the diaphragm (D). The load of control spring (C) now causes the poppet assembly to move downward opening seat area (E) allowing air to flow to meet the downstream demand. The flow of downstream air is metered by the amount of opening (E). Should downstream pressure exceed the desired regulated pressure, the excess pressure will cause the diaphragm (D) to move upward against control spring (C), open vent hole (F), and vent the excess pressure to atmosphere through the hole in the bonnet (H). (This occurs in the relieving type regulator only.)

Electric Motion and Pneumatic Division - Europe

# PB11, PB12 FILTER / REGULATOR – STANDARD

## 1/2 Inch Ports

- Stainless steel construction handles most corrosive environments
- Large diaphragm to valve area ratio for precise regulation and high flow capacity
- Meets NACE specifications MR-01-75/ISO-15156
- Low temperature version available
- High flow: 1/2" – 34 dm<sup>3</sup>/s<sup>§</sup>
- 1/8" female threaded drain

### Symbols



### Options

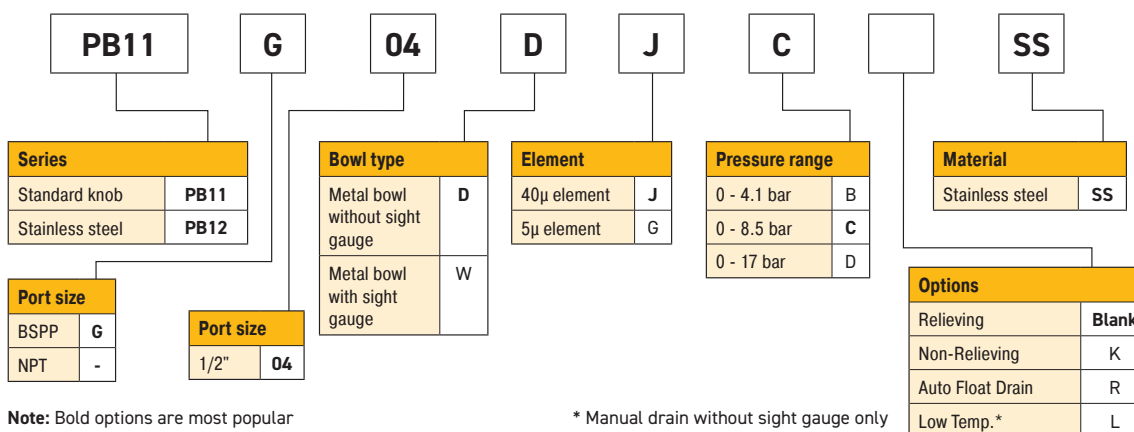

Note: Bold options are most popular

\* Manual drain without sight gauge only

Port size	Series	Description	Order code	Max bar	Height mm	Width mm	Depth mm
G1/2	PB11	BSPP - Standard knob - Manual drain	<b>PB11G04DJCSS</b>	20.7	218	64	60
G1/2	PB11	BSPP - Standard knob - Auto drain	<b>PB11G04DJCRSS</b>	12.0	218	64	60
1/2	PB11	NPT - Standard knob - Manual drain	<b>PB11-04DJCSS</b>	20.7	218	64	60
1/2	PB11	NPT - Standard knob - Auto drain	<b>PB11-04DJCRSS</b>	12.0	218	64	60
G1/2	PB12	BSPP - Tee handle - Manual drain	<b>PB12G04DJCSS</b>	20.7	246	64	60
G1/2	PB12	BSPP - Tee handle - Auto drain	<b>PB12G04DJCRSS</b>	12.0	246	64	60
1/2	PB12	NPT - Tee handle - Manual drain	<b>PB12-04DJCSS</b>	20.7	246	64	60
1/2	PB12	NPT - Tee handle - Auto drain	<b>PB12-04DJCRSS</b>	12.0	246	64	60

§ dm<sup>3</sup>/s = 7 bar inlet pressure with 5.5 bar set pressure and 1 bar pressure drop.

**Warning**

Product rupture can cause serious injury.  
Do not connect regulator to bottled gas.  
Do not exceed maximum primary pressure rating.

Specifications		
Bowl capacity		118 cm <sup>3</sup>
Filter rating		40 micron
Gauge port		1/4
Operation	Fluorocarbon diaphragm	
Port threads		1/2
Operating temperature	PB11 (Metal bowl D or W)	-18°C to 66°C
	PB12 (Metal bowl D)	-18°C to 82°C
	PB12 (Metal bowl W)	-18°C to 66°C
	Auto Float Drain	0°C to 66°C
Option "L" minimum operating temperature		-40°C
Max supply pressure	PB11 (Metal bowl D or W)	0 to 20.7 bar
	PB12 (Metal bowl D)	0 to 20.7 bar
	PB12 (Metal bowl W)	0 to 20.7 bar
	Auto Float Drain	0 to 12 bar
Sump capacity		50 cm <sup>3</sup>
Weight		1090 g

**Note:** Air must be dry enough to avoid ice formation at temperatures below 2°C.

**Note:** "Low Temperature" option is intended for applications where the ambient temperature may be down to -40° C/F. Air supply must be free of moisture to prevent ice formation and malfunction of units. These units contain EPDM seals. Make sure any oils in the airstream are compatible.

Materials of Construction	
Adjustment mechanism / Springs	316 Stainless steel
Body	316 Stainless steel
Bonnet / Tee handle (PB11)	Acetal
Bonnet / Tee handle (PB12)	316 Stainless steel
Bottom plug	316 Stainless steel
Poppet	316 Stainless steel
Seals	Fluorocarbon
Sight gauge	Isoplast

## Dimensions (mm)

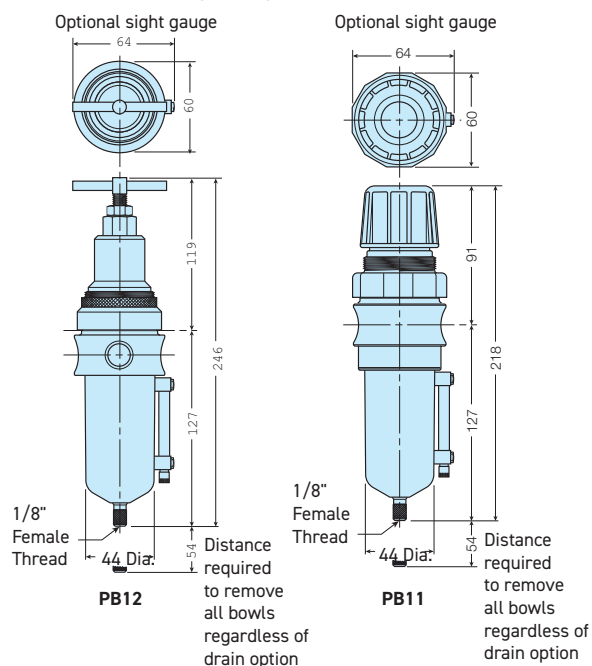

**Note:** 44mm dia. hole required for panel mounting.

Catalog PDE2504TCUK - Stainless Steel FRLs

## Flow Charts

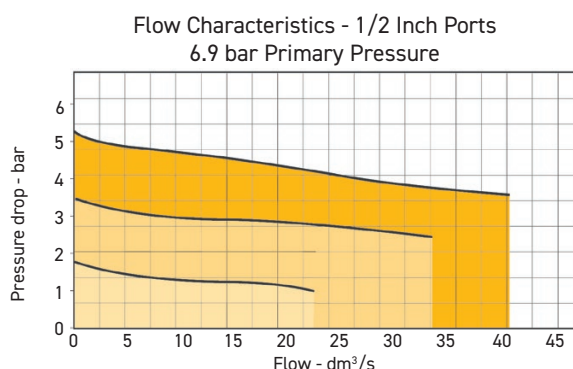

### CAUTION: REGULATOR PRESSURE ADJUSTMENT

The working range of knob adjustment is designed to permit outlet pressures within their full range. Pressure adjustment beyond this range is also possible because the knob is not a limiting device. This is a common characteristic of most industrial regulators, and limiting devices may be obtained only by special design. For best performance, regulated pressure should always be set by increasing the pressure up to the desired setting.

Accessories		
Filter Element Kits	Particulate (40 micron)	<b>EKF10Y</b>
	Particulate (5 micron)	<b>EKF10VY</b>
Gauge - 0 to 10 bar	BSP	<b>M1/4G40S-10</b>
	NPT	<b>K4520N14160SS</b>
Drain Kits	Automatic Float Drain	<b>SA10MDSS</b>
Manual Twist Drain	Small (Old)	<b>SA600Y7-1SS</b>
	Large (New)	<b>SAP05481</b>
Panel Mount Bracket (Stainless)		<b>R10Y57-SS</b>
		<b>R10X51SS</b>
Panel Mount Nut	Stainless	<b>R10X51-P</b>
	Plastic	<b>R10X51-P</b>
Pipe Nipple	1/2" NPT 316 Stainless Steel	<b>616A28-SS</b>
	1/2" BSP 316 Stainless Steel	<b>AC-4SS</b>
Service Kit	Relieving	<b>RKR10YSS</b>
	Non-Relieving	<b>RKR10KYSS</b>

## Operation

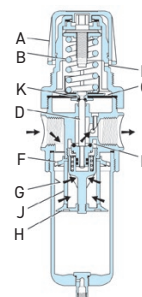

Turning the adjusting knob clockwise applies a load to control spring (B) which forces diaphragm (C) and valve poppet assembly (D) to move downward allowing filtered air to flow through the seat area (E) created between the poppet assembly and the seat. "First stage filtration". Air pressure supplied to the inlet port is directed through deflector plate (F) causing a swirling centrifugal action forcing liquids and coarse particles to the inner bowl wall (G) and down below the lower baffle (H) to the quiet zone. After liquids and large particles are removed in the first stage of filtration "second stage filtration" occurs as air flows through element (J) where smaller particles are filtered out and retained. The air flow now passes through seat area (E) to the outlet port of the unit. Pressure in the downstream line is sensed below the diaphragm (C) and offsets the load of spring (B). When downstream pressure reaches the set-point, poppet valve assembly (D) and diaphragm (C) move upward closing seat area (E). Should downstream pressure exceed the desired regulated pressure, the excess pressure will cause the diaphragm (C) to move upward opening vent hole (K) venting the excess pressure to atmosphere through the hole in the bonnet (L). (This occurs in the standard relieving type filter/regulators only.)

Electric Motion and Pneumatic Division - Europe

# PL10 LUBRICATOR – STANDARD

## 1/2 Inch Ports

- Stainless steel construction handles most corrosive environments
- Fillable under pressure
- Meets NACE specifications MR-01-75/ISO 15156
- High flow: 1/2" - 47 dm<sup>3</sup>/s§
- 1/8" female threaded drain



### Symbols

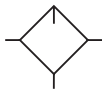

### Options

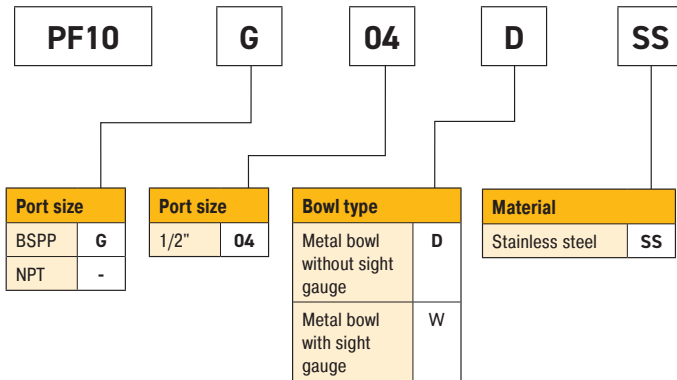

**Note:** Bold options are most popular

Port size	Description	Order code	Max bar	Height mm	Width mm	Depth mm
G1/2	BSPP Manual twist drain - Metal bowl - Without sight gauge	<b>PL10G04DSS</b>	20.7	173	64	60
1/2	NPT Manual twist drain - Metal bowl - Without sight gauge	<b>PL10-04DSS</b>	20.7	173	64	60
G1/2	BSPP Manual twist drain - Metal bowl - With sight gauge	<b>PL10G04WSS</b>	17.2	173	64	60
1/2	NPT Manual twist drain - Metal bowl - With sight gauge	<b>PL10-04WSS</b>	17.2	173	64	60

§ dm<sup>3</sup>/s = Flow at 6.2 bar and a 0.3 bar pressure drop

Specifications		
Bowl capacity	118 cm <sup>3</sup>	
Port threads	1/2	
Operating temperature	Manual twist drain (D)	-18°C to 66°C
	Manual twist drain (W)	-18°C to 66°C
Max supply pressure	Manual twist drain (D)	0 to 20.7 bar
	Manual twist drain (W)	0 to 17.2 bar
Weight	850 g	

**Note:** Air must be dry enough to avoid ice formation at temperatures below 2°C.

Materials of Construction	
Body	316 Stainless steel
Bowl	316 Stainless steel
Dip tube	316 Stainless steel
Drain	316 Stainless steel
Fill plug	316 Stainless steel
Seals	Flourocarbon
Sight dome	Nylon
Sight gauge	Isoplast

## Dimensions (mm)

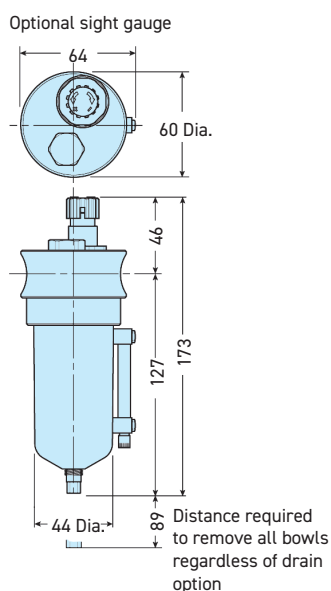

## Flow Charts

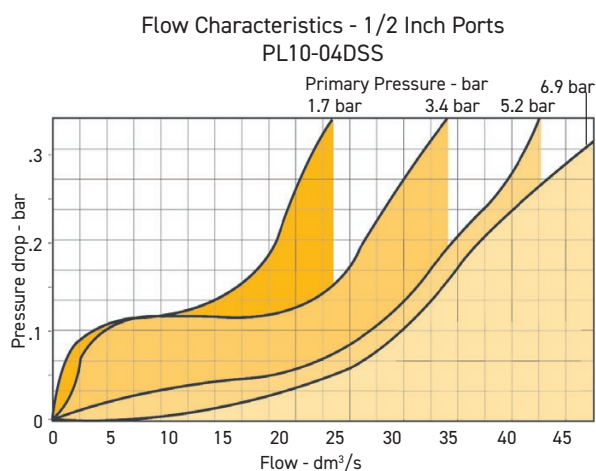

Accessories		
Manual twist drain	Small (Old)	<b>SA600Y7-1SS</b>
	Large (New)	<b>SAP05481</b>
Pipe nipple	1/2" NPT 316 Stainless Steel	<b>616A28-SS</b>
	1/2" BSP 316 Stainless Steel	<b>AC-4SS</b>
Sight dome kit		<b>RKL10SS</b>

## Operation

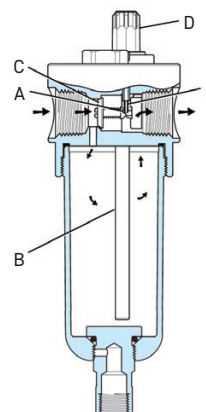

Air flowing through the unit goes through two paths. At low flow rates the majority of the air flows through the Venturi section (A). The rest of the air opens the check valve (C). The velocity of the air flowing through the Venturi section (A) creates a pressure drop. This lower pressure allows the oil to be forced from the reservoir through the pickup tube (B) and travels up to the metering screw (D). The rate of oil delivery is then controlled by adjusting the metering screw (D). Oil flows past the metering screw (D) and forms a drop in the nozzle tube (E). As the oil drops through the dome (F) and back into the Venturi section (A), it is broken up into fine particles. It is then mixed with the air flowing past the check valve (C) and is carried downstream. As the air flow increases the check valve (C) will open more fully. This additional flow will assure that the oil delivery rate will increase linearly with the increase of air flow.





Parker Hannifin Corporation  
**Parker Hannifin EMEA Sàrl**  
European Headquarters  
La Tuilière 6 Etoy  
Switzerland CH-1163  
[www.parker.com](http://www.parker.com)

PDE2504TCUK

08/2025

Your Local Authorized Parker Distributor

© 2025 Parker Hannifin Corporation

