



SPORLAN

Thermostatic Expansion Valves

With Selective Thermostatic Charges



ENGINEERING YOUR SUCCESS.

⚠ WARNING – USER RESPONSIBILITY

Failure or improper selection or improper use of the products described herein or related items can cause death, personal injury and property damage.

This document and other information from Parker Hannifin Corporation, its subsidiaries and authorized distributors provide product or system options for further investigation by users having technical expertise.

The user, through its own analysis and testing, is solely responsible for making the final selection of the system and components and assuring that all performance, endurance, maintenance, safety and warning requirements of the application are met. The user must analyze all aspects of the application, follow applicable industry standards, and follow the information concerning the product in the current product catalog and in any other materials provided from Parker or its subsidiaries or authorized distributors.

To the extent that Parker or its subsidiaries or authorized distributors provide component or system options based upon data or specifications provided by the user, the user is responsible for determining that such data and specifications are suitable and sufficient for all applications and reasonably foreseeable uses of the components or systems.

OFFER OF SALE

The items described in this document are hereby offered for sale by Parker Hannifin Corporation, its subsidiaries or its authorized distributors. This offer and its acceptance are governed by the provisions stated in the detailed "Offer of Sale" available at www.parker.com.

▼ THERMOSTATIC EXPANSION VALVES

10 Outstanding Features & Benefits of Sporlan Thermostatic Expansion Valves

- **SELECTIVE THERMOSTATIC CHARGES**
Designed to provide optimum performance for all applications — air conditioning and heat pump, medium and low temperature refrigeration.
- **THERMOSTATIC ELEMENT DESIGN**
Long lasting and field proven stainless steel diaphragm and welded element construction.
- **DIAPHRAGM DESIGN**
Large flat diaphragm permits precise valve control.
- **REPLACEABLE THERMOSTATIC ELEMENTS**
Field replaceable elements on all standard valves.
- **ACCESSIBLE INTERNAL PARTS**
Durable, leakproof body joint construction allows the valve to be disassembled, and the internal parts cleaned and inspected.
- **PIN CARRIER DESIGN (CONVENTIONAL VALVES)**
Provides precise pin and port alignment, and tighter seating.
- **BALANCED PORT DESIGN**
Provides perfect pin and port alignment, and prevents changes in pressure drop across the valve from influencing valve operation. Provides excellent control on applications with widely varying operating conditions.
- **MATERIALS OF CONSTRUCTION**
Pin and port materials offer maximum protection against corrosion and erosion.
- **SILVER SOLDERED CONNECTIONS**
For leakproof, high strength connection-to-body joints.
- **ADJUSTABLE SUPERHEAT DESIGN**
All standard valves are externally adjustable.

The thermostatic expansion valve (TEV) controls the flow of liquid refrigerant entering the direct expansion (DX) evaporator by maintaining a constant **superheat** of the refrigerant vapor at the outlet of the evaporator. The TEV controls the difference between the actual temperature and the saturation temperature of the refrigerant corresponding to the suction pressure at the sensing bulb location; this is superheat. By controlling

superheat, the TEV keeps most of the evaporator surface active, while preventing liquid refrigerant from returning to the compressor. The ability of the TEV to match refrigerant flow to the rate at which refrigerant can be vaporized in the evaporator makes the TEV the ideal expansion device for most air conditioning and refrigeration applications.

TABLE OF CONTENTS

Selection Procedure	2	BQ, EBQ, & SBQ	17-21
Valve Nomenclature / Ordering Instructions	3	G	22
Recommended Thermostatic Charges	3	EG	23
TEV Capacity Ratings for Refrigerants:		BF	24
22, 134a, 401A, 402A, 404A, 407C, 408A, 409A, 410A,		SBF & EBF	25-26
422D, and 507	3	S	27
Capacity Tables for Refrigerants:		EBS	28
22, 134a, 401A, 402A, 404A, 407C, 408A, 409A, 410A,		O	29-30
422D, and 507	4-8	H	31
TEV Quick Reference Guide	9-11	M	32
Valve Specifications		V	33
RC	12	W	34
ER	13	Materials and Details of Construction	35
F & EF	15-16	OEM Type Thermostatic Expansion Valves	36
Q, EQ, & SQ	17-21	Terms of Sale with Warranty Limitations	37

Refer to Bulletin 10-9 for a complete discussion on **The Theory of Operation and Application of Thermostatic Expansion Valves**.
Refer to Bulletin 10-11 for a complete discussion on **Installing and Servicing Thermostatic Expansion Valves**.

FOR USE ON REFRIGERATION and/or AIR CONDITIONING SYSTEMS ONLY

Bulletin 10-10, April 2011 supersedes Bulletin 10-10, October 2009 and all prior publications.

SELECTION PROCEDURE

The following procedure should be used when selecting a Sporlan TEV:

1. Determine the liquid temperature of the refrigerant entering the valve.

The TEV capacity tables on pages 4 to 8 are based on a liquid temperature of 100°F for R-22, R-134a, R-401A, R-402A, R-404A, R-407C, R-408A, R-409A, R-410A, and R-507. For other liquid temperatures, apply the correction factor given in the tables for each refrigerant. For example see Table B.

2. Determine pressure drop across valve.

The pressure drop correction factors are based on standard liquid temperature and pressure drop. The standard pressure drop is dependent on the evaporator temperature. To determine the pressure drop, subtract the saturated pressure equivalent to evaporator temperature from the condensing pressure. The condensing pressure used in this calculation should be the minimum operating condensing pressure of the system. From this value, subtract all other pressure losses to obtain the net pressure drop across the valve. Use this value to determine the pressure drop correction factor. For example see Table C. Be sure to consider all of the following possible sources of pressure drop:

1. Friction losses through refrigeration lines including the evaporator and condenser.
2. Pressure drop across liquid line accessories such as a solenoid valve and filter-drier.
3. Static pressure loss (gain) due to the vertical lift (drop) of the liquid line.
4. Pressure drop across a refrigerant distributor if used.

Refer to Bulletin 20-10 for information on refrigerant distributors.

3. Select valve from the capacity tables.

Select a valve based on the design evaporating temperature. If possible the valve capacity should be equal or slightly exceed the design rating of the system. Be sure to apply the appropriate correction factors for liquid temperature and pressure drop. Once the desired valve capacity has been located, determine the nominal capacity of the valve from the tables' second column. On multiple evaporator systems, select each valve on the basis of individual evaporator capacity. For example see Table A.

4. Determine if an external equalizer is required.

The amount of pressure drop between the valve outlet and bulb location will determine if an external equalizer is required. Refer to Bulletin 10-9 for further information on this subject.

5. Select body type.

Select the body type according to the style connections desired. For complete specifications on each TEV type including nominal ratings, refer to pages 9 to 11.

6. Select the Sporlan Selective Thermostatic Charge.

Select the charge according to the design evaporating temperature from the Table on page 3. Refer to Bulletin 10-9 for a complete discussion of the available Sporlan Selective Thermostatic Charges.

Selection Example – Refrigerant 22

Application: medium temperature refrigeration

Design evaporator temperature 20°F
 Design condenser temperature 95°F
 Refrigerant liquid temperature 70°F
 Design system capacity 1 ton

Available pressure drop across TEV:

Condensing pressure (psig) 182
 Evaporating pressure (psig) 43

 139

Liquid line and accessories loss (psi) - 4
 Distributor and tubes loss (psi) ① - 35

 100

Refrigerant liquid correction factor 1.17
 Pressure drop correction factor 0.89

Use the following formula to calculate TEV capacity:

$$\text{TEV Capacity} = \text{TEV rating} \times \text{CF liquid temperature} \times \text{CF pressure drop}$$

EGVE-1 has valve capacity of: $1.09 \times 1.17 \times 0.89 = 1.14$ Tons at 20°F evaporating temperature, 100 psi pressure drop and 70° liquid temperature.

Thermostatic charge (from table on page 3): VC ②

Selection:

EGVE-1-C 3/8" x 1/2" x 1/4" ODF x 5"

① An externally equalized valve must be used on evaporators employing a refrigerant distributor due to the pressure drop created by the distributor. In addition, an externally equalized valve should always be used with air conditioning thermostatic charges to reduce the possibility of thermostatic charge migration.

② Please note that the refrigerant charge designation in the thermostatic charge ("V" in this case) is dropped when it is incorporated into the valve model designation.

THERMOSTATIC EXPANSION VALVE CAPACITIES for REFRIGERANTS - TONS

VALVE TYPES	NOMINAL CAPACITY	REFRIGERANT 22					
		RECOMMENDED THERMOSTATIC VC, VCP100, VGA		VZ, VZP40			
		EVAPORATOR TEMPERATURE °F					
F-EF-G-EG	1/5	0.20	0.32	0.19	0.17	0.15	0.1
F-EF-G-EG	1/3	0.35	0.38	0.33	0.27	0.24	0.1
F-EF-G-EG	1/2	0.45	0.49	0.43	0.35	0.31	0.2
F-EF-G-EG	3/4	0.75	0.69	0.71	0.68	0.61	0.4
G-EG	1	1.00	1.09	0.95	0.86	0.77	0.5
F-EF-G-EG	1-1/2	1.60	1.77	1.52	1.22	1.09	0.8

The valve capacity should equal or slightly exceed the tonnage rating of the system. (For complete R-22 capacity tables, see pages 4 and 5.)

Design Evaporating Temperature

Table A

REFRIGERANT	LIQUID TEMPERATURE ENTERING TEV °F								
	0°	10°	20°	30°	40°	50°	60°	70°	80°
22	1.56	1.51	1.45	1.40	1.34	1.29	1.23	1.17	1.1
407C	1.69	1.62	1.55	1.49	1.42	1.35	1.28	1.21	1.1

Table B

EVAPORATOR TEMPERATURE °F	PRESSURE DROP ACROSS TEV (psi)						
	30	50	75	100	125	150	175
40°	0.55	0.71	0.87	1.00	1.12	1.22	1.32
20° & 0°	0.49	0.63	0.77	0.89	1.00	1.10	1.18
10° & -20°	0.45	0.58	0.71	0.82	0.91	1.00	1.08
-40°	0.41	0.53	0.65	0.76	0.85	0.93	1.00

Table C

SELECTION PROCEDURE

7. Valve Nomenclature / Ordering Instructions

Combine the letters and numbers in the following manner to obtain the complete valve designation. Also include all connection sizes and the capillary tube length.

EXAMPLE

EG	V	E	1	C	3/8" ODF SOLDER	x	1/2" ODF SOLDER	x	1/4" ODF SOLDER	x	5'
Body Type	Sporlan Code – Refrigerant Element Label Color Code F = R-12 Yellow E = R-13 Blue V = R-22 Green G = R-23 Blue M = R-124 Blue J = R-134a Blue X = R-401A Pink L = R-402A Sand S = R-404A Orange V = R-407A Green N = R-407C Lt. Brown S = R-408A Purple F = R-409A Yellow Z = R-410A Rose V = R-422D Green R = R-502 Purple W = R-503 Blue P = R-507 Teal W = R-508B Blue	"E" specifies external equalizer. Omission of letter "E" indicates valve with internal equalizer. e.g. EGV-1-C	Nominal Capacity in Tons	Thermostatic Charge	Inlet Connection Size and Style		Outlet Connection Size and Style		External Equalizer Connection Size and Style		Capillary Tubing Length Inches or Feet

RECOMMENDED THERMOSTATIC CHARGES*

SPORLAN SELECTIVE CHARGES ENGINEERED for PEAK PERFORMANCE for EACH SPECIFIC APPLICATION

APPLICATION	REFRIGERANT										ACTUAL THERMOSTATIC CHARGES
	12, 409A	22, 422D, 407A	410A	134a	401A	402A	404A, 408A	407C	502	507	
Air Conditioning	FCP60	—	—	JCP60	XCP60	—	—	—	—	—	JCP60
	—	VCP100	—	—	—	—	—	NCP100	—	—	VCP100
	—	—	ZCP180	—	—	—	—	—	—	—	ZCP180
	—	VGA	—	—	—	—	—	NGA	—	—	VGA
	—	—	—	—	—	—	SCP115	—	RCP115	—	SCP115
Commercial Refrigeration 50°F to -10°F	—	—	ZGA	—	—	—	—	—	—	—	ZGA
	FC	—	—	JC	XC	—	—	—	—	—	JC
	—	VC	—	—	—	—	—	NC	—	—	VC
	—	—	—	—	—	—	SC	—	RC	—	SC
Low Temperature Refrigeration 0°F to -40°F	—	—	—	—	—	—	—	—	—	PC	PC
	FZ	—	—	—	—	—	—	—	—	—	JZ
	FZP	—	—	—	—	—	—	—	—	—	JZP
	—	VZ	—	—	—	—	—	—	—	—	VZ
	—	VZP40	—	—	—	—	—	—	—	—	VZP40
Extreme Low Temperature Refrigeration -40°F to -100°F	—	—	—	—	—	LZ	SZ	—	RZ	PZ	SZ
	—	—	—	—	—	LZP	SZP	—	RZP	PZP	SZP
	—	VX	—	—	—	—	—	—	—	—	VX
—	—	—	—	—	LX	SX	—	RX	PX	SX	

*APPLICATION FACTORS:

- The Type ZP charges have essentially the same characteristics as the Type Z charge with one exception: they produce a pressure limit Maximum Operating Pressure (MOP). ZP charges are not intended as replacements for Z charges. Each should be selected for its own unique purpose.
- All air conditioning and heat pump charges are intended for use with externally equalized valves.
- Type L liquid charges are also available for most commonly used refrigerants in most element sizes.
- The Type X charges are not to be used with "EBS" and "O" valves.
- If in doubt as to which charge to use, review the section on thermostatic charges in Bulletin 10-9 or contact Sporlan Division of Parker, Washington, Missouri with complete system data.
- For dual temperature applications, use the "C" charge.
- The "C" charge may be used on applications down to -30°F on R-22, R-404A and R-507.

TEV CAPACITY RATINGS

FOR REFRIGERANTS: 22, 134a, 401A, 402A, 404A, 407C, 408A, 409A, 410A, 422D, 507

TEV capacity ratings for R-22, R-134a, R-401A, R-402A, R-404A, R-407C, R-408A, R-409A, R-410A, R-422D, and R-507 are based on vapor free 100°F liquid refrigerant entering the expansion valve, a maximum opening superheat of 7°F, and a standard factory air test superheat setting. A discussion of the relationship between valve capacities and superheat settings can be found in Bulletin 10-9.

The ratings for evaporator temperatures 40°F, 20°F, -10°F, -40°F in the capacity tables are in accordance with ANSI/ARI

Standard Number 750. TEVs are tested in accordance with ANSI/ASHRAE 17.

TEV models featuring the mechanical pressure limit style thermostatic elements, i.e., the Types G(PL) and C(PL) TEVs, are now obsolete. Consult Bulletin 210-10-17 for additional information on this subject and replacement valves.

For TEV capacity ratings at operating conditions not shown in the following tables, contact Sporlan Division of Parker.

▼ THERMOSTATIC EXPANSION VALVE CAPACITIES for REFRIGERANTS - TONS OF REFRIGERATION

22, 422D, 407C

AIR CONDITIONING and HEAT PUMP APPLICATIONS

VALVE TYPES	NOMINAL CAPACITY	REFRIGERANT								
		22			422D [Ⓞ]			407C		
		RECOMMENDED THERMOSTATIC CHARGE								
		VCP100, VGA [Ⓢ]								
EVAPORATOR TEMPERATURE °F										
40° 20° 0° 40° 20° 0° 40° 20° 0°										
ER, RC	1	1.0	1.1	1.0	0.71	0.76	0.66	0.9	1.0	0.9
ER, RC	1-1/2	1.8	1.9	1.7	1.25	1.32	1.15	1.6	1.7	1.5
ER, RC	2	2.3	2.5	2.2	1.64	1.74	1.51	2.1	2.3	2.0
ER, RC	3	3.2	3.5	3.1	2.28	2.42	2.10	2.9	3.2	2.8
ER, RC	4	4.2	4.6	4.1	2.99	3.17	2.75	3.9	4.1	3.6
ER, RC	5	5.0	5.5	4.9	3.56	3.78	3.27	4.6	4.9	4.3
ER, RC	6	6.0	6.5	5.3	4.28	4.53	3.54	5.5	5.9	4.7
ER	8	8.0	8.7	7.8	5.70	6.04	5.24	7.4	7.9	6.9
ER	10	10.4	11.4	10.2	7.44	7.88	6.83	9.6	10.3	9.0
ER	12	12.1	13.2	11.8	8.62	9.14	7.92	11.1	11.9	10.5

REFRIGERANT	LIQUID TEMPERATURE ENTERING TEV °F														
	0°	10°	20°	30°	40°	50°	60°	70°	80°	90°	100°	110°	120°	130°	140°
	CORRECTION FACTOR, CF LIQUID TEMPERATURE														
22	1.56	1.51	1.45	1.40	1.34	1.29	1.23	1.17	1.12	1.06	1.00	0.94	0.88	0.82	0.76
422D	1.99	1.90	1.80	1.70	1.60	1.50	1.41	1.31	1.20	1.10	1.00	0.90	0.79	0.68	0.57
407C	1.69	1.62	1.55	1.49	1.42	1.35	1.28	1.21	1.14	1.07	1.00	0.93	0.85	0.77	0.69

These factors include corrections for liquid refrigerant density and net refrigerating effect and are based on an evaporator temperature of 0°F. However, they may be used for any evaporator temperature from -40°F to 40°F since the variation in the actual factors across this range is insignificant.

EVAPORATOR TEMPERATURE °F	PRESSURE DROP ACROSS TEV (psi)											
	30	50	75	100	125	150	175	200	225	250	275	300
	CORRECTION FACTOR, CF PRESSURE DROP											
40°	0.55	0.71	0.87	1.00	1.12	1.22	1.32	1.41	1.50	1.58	1.66	1.73
20° & 0°	0.49	0.63	0.77	0.89	1.00	1.10	1.18	1.26	1.34	1.41	1.48	1.55

TEV Capacity = TEV Rating x CF Liquid Temperature x CF Pressure Drop — Example: Actual capacity of a nominal 2 ton R-22 Type S valve at 20°F evaporator, 100 psi pressure drop across the TEV, and 90°F liquid temperature entering the TEV = 2.18 (from rating chart) x 1.06 (CF liquid temperature) x 0.89 (CF pressure drop) = 2.06 tons.

Ⓞ R-422D can be used in a system with R-22 valves, but the TEV capacity will be reduced. Please verify valve capacity will handle system load.
 Ⓢ The RC valve for R-22 applications is only available with a VGA element.

▼ THERMOSTATIC EXPANSION VALVE CAPACITIES for REFRIGERANTS - TONS OF REFRIGERATION

410A

AIR CONDITIONING and HEAT PUMP APPLICATIONS

VALVE TYPES	NOMINAL CAPACITY	REFRIGERANT		
		410A		
		RECOMMENDED THERMOSTATIC CHARGE		
		ZCP180, ZGA [Ⓢ]		
EVAPORATOR TEMPERATURE °F				
40° 20° 0°				
ER, RC	1	1.2	1.3	1.2
ER, RC	1-1/2	2.1	2.3	2.0
ER, RC	2	2.7	3.0	2.7
ER, RC	3	3.8	4.1	3.7
ER, RC	4	5.0	5.4	4.9
ER, RC	5	5.9	6.5	5.8
ER, RC	6	7.1	7.8	6.3
ER	8	9.5	10.4	9.3
ER	12-1/2	12.3	13.5	12.1
ER	15	14.3	15.7	14.0

VALVE TYPES	NOMINAL CAPACITY	REFRIGERANT		
		410A		
		RECOMMENDED THERMOSTATIC CHARGE		
		ZCP180, ZGA		
EVAPORATOR TEMPERATURE °F				
40° 20° 0°				
OZE-20	20	19.7	21.6	20.4
OZE-25	25	23.7	25.9	24.5
OZE-35	35	32.6	35.6	33.6
OZE-50	50	49.3	54.0	51.0
OZE-60	60	59.2	64.8	61.2

VALVE TYPES	CARTRIDGE TYPE	80	120	160	200	240	280	320	360
BQ, EBQ, SBQ	AAA	1/3	0.4	0.5	0.4				
BQ, EBQ, SBQ	AA	3/4	0.9	1.0	0.9				
BQ, EBQ, SBQ	A	1-3/4	1.9	2.1	1.8				
BQ, EBQ, SBQ	B	3-1/2	3.4	3.7	3.2				
BQ, EBQ, SBQ	C	6	6.2	6.8	5.9				

REFRIGERANT	LIQUID TEMPERATURE ENTERING TEV °F													
	40	50	60	70	80	90	100	110	120	130	140			
	CORRECTION FACTOR, CF LIQUID TEMPERATURE													
410A	1.39	1.31	1.23	1.17	1.12	1.06	1.00	0.94	0.88	0.82	0.76			

EVAPORATOR TEMPERATURE °F	PRESSURE DROP ACROSS TEV (psi)								
	80	120	160	200	240	280	320	360	
	CORRECTION FACTOR, CF PRESSURE DROP								
40°	0.71	0.87	1.00	1.12	1.22	1.32	1.41	1.50	
20° & 0°	0.63	0.77	0.89	1.00	1.10	1.18	1.26	1.34	

Ⓢ The RC valve for R-410A applications is only available with a ZGA element.

THERMOSTATIC EXPANSION VALVE CAPACITIES for REFRIGERANTS - TONS OF REFRIGERATION

404A, 408A

COMMERCIAL and LOW TEMPERATURE REFRIGERATION APPLICATIONS

VALVE TYPES	NOMINAL CAPACITY	REFRIGERANT																					
		404A						408A															
		RECOMMENDED THERMOSTATIC CHARGE																					
		SC, SCP115			SZ, SZP			SC, SCP115			SZ, SZP												
EVAPORATOR TEMPERATURE °F																							
												40°	20°	0°	-10°	-20°	-40°	40°	20°	0°	-10°	-20°	-40°
F-EF-G-EG	1/8	0.15	0.16	0.15	0.15	0.13	0.11	0.20	0.21	0.20	0.22	0.19	0.16										
F-EF-G-EG	1/6	0.23	0.24	0.23	0.24	0.21	0.17	0.31	0.33	0.32	0.34	0.30	0.25										
F-EF-G-EG	1/4	0.29	0.31	0.29	0.31	0.27	0.22	0.39	0.42	0.41	0.43	0.38	0.32										
F-EF-G-EG	1/2	0.56	0.59	0.56	0.59	0.51	0.42	0.75	0.81	0.77	0.83	0.72	0.61										
F-EF-G-EG	1	1.02	1.10	1.04	1.10	0.94	0.79	1.37	1.50	1.44	1.54	1.34	1.14										
F-EF-G-EG	1-1/2	1.53	1.61	1.39	1.47	1.26	1.05	2.05	2.19	1.92	2.06	1.79	1.53										
F&E(Ext)-G&E(Ext)-S	2	2.04	2.14	1.84	1.96	1.68	1.40	2.74	2.92	2.54	2.74	2.38	2.04										
S	3	2.86	3.00	2.52	2.45	2.10	1.75	3.83	4.08	3.48	3.43	2.98	2.54										
S	4	4.08	4.28	3.60	3.42	2.94	2.45	5.48	5.83	4.97	4.80	4.17	3.56										
S(Ext)	6	5.61	5.12	4.27	4.52	3.84	2.97	7.53	6.97	5.90	6.34	5.45	4.32										
S(Ext)	7	7.14	6.51	5.44	5.76	4.90	3.79	9.58	8.87	7.50	8.08	6.94	5.51										
H	3	2.85	2.72	2.32	2.45	2.08	1.65	3.83	3.71	3.20	3.434	2.95	2.41										
H	4	4.08	3.89	3.15	3.42	2.91	2.32	5.48	5.30	4.34	4.80	4.13	3.37										
H	6-1/2	6.63	6.33	5.12	5.32	4.52	3.60	8.90	8.61	7.06	7.46	6.41	5.24										
H	9	9.69	9.25	7.48	6.11	5.19	4.13	13.0	12.6	10.3	8.57	7.36	6.01										
H	12	13.3	12.7	10.2	9.79	8.31	6.62	17.8	17.2	14.1	13.7	11.8	9.60										
M	15	16.1	17.1	13.1	13.8	12.4	10.0	21.6	23.3	18.0	19.3	17.5	14.5										
M	20	21.0	22.3	16.4	17.3	15.5	12.5	28.2	30.3	22.7	24.2	22.0	18.2										
M	25	26.2	27.8	20.5	20.3	18.2	14.7	35.2	37.8	28.3	28.4	25.8	21.4										
M	30	31.6	33.5	24.7	23.5	21.1	17.0	42.4	45.7	34.1	32.9	29.9	24.7										

BALANCED PORT THERMOSTATIC EXPANSION VALVES

BF-EBF-SBF	AAA	0.23	0.24	0.23	0.24	0.21	0.17	0.31	0.33	0.32	0.34	0.30	0.25
BF-EBF-SBF	AA	0.46	0.49	0.46	0.45	0.39	0.32	0.62	0.66	0.64	0.63	0.55	0.47
BF-EBF-SBF	A	1.02	1.10	1.04	1.10	0.94	0.79	1.37	1.50	1.44	1.54	1.34	1.14
BF-EBF-SBF	B	1.89	1.98	1.66	1.60	1.37	1.14	2.53	2.70	2.30	2.24	1.95	1.66
BF-EBF-SBF	C	2.86	3.00	2.50	2.45	2.10	1.75	3.83	4.08	3.48	3.43	2.98	2.54
EBS	6	5.71	5.63	4.61	4.15	3.28	2.97	7.67	7.66	6.40	5.82	4.66	4.32
EBS	7-1/2	7.75	7.64	6.26	5.28	4.18	3.78	10.4	10.4	8.68	7.41	5.93	5.49
EBS	10	9.54	9.63	7.25	6.72	5.56	4.64	12.8	13.2	10.0	9.42	7.88	6.74
EBS	13	13.6	14.0	10.2	9.54	8.00	6.15	18.3	19.0	14.2	13.4	11.4	8.94
O	9	9.69	9.24	7.24	6.11	5.31	4.43	13.0	12.6	10.1	8.57	7.53	6.44
O	12	13.3	12.6	9.91	9.74	8.46	7.06	17.8	17.2	13.8	13.6	12.0	10.3
O	21	21.4	20.4	14.3	11.7	10.1	8.46	28.8	27.8	19.8	16.4	14.4	12.3
O	30	30.8	32.3	23.0	17.5	15.2	12.7	41.4	44.0	32.0	24.5	21.5	18.4
O	35	35.7	37.4	26.7	19.0	16.5	13.8	47.9	51.0	37.0	26.6	23.4	20.0
O	45	45.9	48.1	34.3	21.9	19.0	15.9	61.6	65.6	47.6	30.7	26.9	23.1
V	38	38.7	39.4	33.6	33.2	30.5	24.1	52.0	53.7	46.6	46.6	43.2	35.1
V	50	52.0	52.9	45.1	47.4	43.5	34.4	69.8	72.1	62.6	66.5	61.7	50.0
V	70	71.4	72.6	62.7	66.4	60.9	48.1	95.8	99.0	87.0	93.1	86.4	70.0

REPLACEABLE CARTRIDGE THERMOSTATIC EXPANSION VALVES

VALVE TYPES	CARTRIDGE NO.	REPLACEABLE CARTRIDGE THERMOSTATIC EXPANSION VALVES												
Q-EQ-SQ	0	1/6	0.20	0.22	0.20	0.20	0.17	0.14	0.27	0.30	0.28	0.28	0.24	0.21
Q-EQ-SQ	1	1/4	0.46	0.49	0.46	0.45	0.39	0.32	0.62	0.66	0.64	0.63	0.55	0.47
Q-EQ-SQ	2	1/2	0.66	0.72	0.67	0.59	0.51	0.42	0.89	0.98	0.94	0.83	0.72	0.61
Q-EQ-SQ	3	1	1.02	1.07	0.89	0.85	0.73	0.61	1.37	1.46	1.24	1.19	1.03	0.88
Q-EQ-SQ	4	1-1/2	1.63	1.71	1.44	1.47	1.26	1.05	2.19	2.33	1.99	2.06	1.79	1.53
Q-EQ-SQ	5	2	2.14	2.25	1.88	1.96	1.68	1.40	2.88	3.06	2.61	2.74	2.38	2.04
Q-EQ-SQ	6	3	2.86	3.00	2.51	2.45	2.11	1.75	3.83	4.08	3.48	3.43	2.98	2.54

BQ-EBQ-SBQ Balanced port replaceable cartridges, AAA, AA, A, B and C, have the same capacities as the matching nominal capacity of the standard balanced port valves above.

REFRIGERANT	LIQUID TEMPERATURE ENTERING TEV °F														
	0°	10°	20°	30°	40°	50°	60°	70°	80°	90°	100°	110°	120°	130°	140°
404A	2.04	1.94	1.84	1.74	1.64	1.54	1.43	1.33	1.22	1.11	1.00	0.89	0.77	0.65	0.53
408A	1.66	1.60	1.54	1.47	1.40	1.34	1.27	1.21	1.14	1.07	1.00	0.93	0.86	0.79	0.71

These factors include corrections for liquid refrigerant density and net refrigerating effect and are based on an evaporator temperature of 0°F. However, they may be used for any evaporator temperature from -40°F to 40°F since the variation in the actual factors across this range is insignificant.

EVAPORATOR TEMPERATURE °F	PRESSURE DROP ACROSS TEV (psi)										
	30	50	75	100	125	150	175	200	225	250	275
40°	0.55	0.71	0.87	1.00	1.12	1.22	1.32	1.41	1.50	1.58	1.66
20° & 0°	0.49	0.63	0.77	0.89	1.00	1.10	1.18	1.26	1.34	1.41	1.48
-10° & -20°	0.45	0.58	0.71	0.82	0.91	1.00	1.08	1.15	1.22	1.29	1.35
-40°	0.41	0.53	0.65	0.76	0.85	0.93	1.00	1.07	1.13	1.20	1.25

TEV Capacity = TEV Rating x CF Liquid Temperature x CF Pressure Drop — Example: Actual capacity of a nominal 1-1/2 ton R-404A Type EG valve at -20°F evaporator, 125 psi pressure drop across the TEV, and 60°F liquid temperature entering the TEV = 1.26 (from rating chart) x 1.43 (CF liquid temperature) x 0.91 (CF pressure drop) = 1.64 tons.

THERMOSTATIC EXPANSION VALVE CAPACITIES for REFRIGERANTS - TONS OF REFRIGERATION

402A, 507

COMMERCIAL and LOW TEMPERATURE REFRIGERATION APPLICATIONS

VALVE TYPES	NOMINAL CAPACITY	REFRIGERANT												
		402A						507						
		RECOMMENDED THERMOSTATIC CHARGE												
		LC			LZ, LZP			PC			PZ, PZP			
EVAPORATOR TEMPERATURE °F														
		40°	20°	0°	-10°	-20°	-40°	40°	20°	0°	-10°	-20°	-40°	
F-EF-G-EG	1/8	0.15	0.16	0.15	0.16	0.13	0.11	0.14	0.15	0.14	0.15	0.13	0.11	
F-EF-G-EG	1/6	0.23	0.24	0.23	0.24	0.21	0.18	0.22	0.24	0.22	0.24	0.20	0.17	
F-EF-G-EG	1/4	0.29	0.31	0.29	0.31	0.27	0.23	0.29	0.30	0.29	0.30	0.26	0.22	
F-EF-G-EG	1/2	0.56	0.59	0.56	0.59	0.51	0.43	0.55	0.58	0.54	0.58	0.50	0.41	
F-EF-G-EG	1	1.02	1.10	1.04	1.11	0.95	0.80	1.00	1.08	1.01	1.08	0.93	0.77	
F-EF-G-EG	1-1/2	1.52	1.61	1.39	1.48	1.27	1.07	1.50	1.57	1.36	1.44	1.24	1.03	
F&F(Ext)-G&EG(Ext)-S	2	2.03	2.14	1.84	1.97	1.70	1.42	2.00	2.09	1.79	1.92	1.65	1.38	
S	3	2.85	3.00	2.52	2.47	2.12	1.78	2.79	2.93	2.45	2.40	2.06	1.72	
S	4	4.07	4.28	3.60	3.45	2.97	2.49	3.99	4.19	3.50	3.36	2.89	2.41	
S (Ext)	6	5.59	5.12	4.27	4.56	3.88	3.02	5.49	5.00	4.16	4.43	3.77	2.93	
S (Ext)	7	7.12	6.51	5.44	5.81	4.95	3.85	6.99	6.36	5.30	5.65	4.80	3.73	
H	3	2.85	2.72	2.32	2.46	2.10	1.68	2.79	2.66	2.26	2.40	2.04	1.63	
H	4	4.07	3.89	3.15	3.45	2.94	2.36	3.99	3.81	3.07	3.36	2.86	2.28	
H	6-1/2	6.61	6.33	5.12	5.36	4.57	3.66	6.49	6.18	4.98	5.22	4.44	3.54	
H	9	9.66	9.25	7.48	6.16	5.25	4.20	9.48	9.04	7.28	5.99	5.09	4.07	
H	12	13.2	12.7	10.2	9.86	8.40	6.73	13.0	12.4	10.0	9.59	8.16	6.52	
M	15	16.1	17.1	13.1	13.9	12.5	10.2	15.8	16.7	12.7	13.5	12.1	9.83	
M	20	20.9	22.3	16.4	17.4	15.7	12.7	20.6	21.8	16.0	16.9	15.2	12.3	
M	25	26.1	27.8	20.5	20.4	18.4	14.9	25.6	27.2	20.0	19.9	17.9	14.5	
M	30	31.5	33.5	24.7	23.6	21.3	17.3	30.9	32.8	24.1	23.0	20.7	16.7	
BALANCED PORT THERMOSTATIC EXPANSION VALVES														
BF-EBF-SBF	AAA	0.23	0.24	0.23	0.24	0.21	0.18	0.23	0.24	0.22	0.24	0.21	0.17	
BF-EBF-SBF	AA	0.46	0.49	0.46	0.45	0.39	0.33	0.45	0.48	0.45	0.44	0.38	0.32	
BF-EBF-SBF	A	1.02	1.10	1.04	1.11	0.95	0.80	1.00	1.08	1.01	1.08	0.93	0.77	
BF-EBF-SBF	B	1.88	1.98	1.66	1.61	1.39	1.16	1.85	1.94	1.62	1.57	1.35	1.12	
BF-EBF-SBF	C	2.85	3.00	2.52	2.47	2.12	1.78	2.79	2.93	2.45	2.40	2.06	1.72	
EBS	6	5.69	5.63	4.63	4.18	3.32	3.01	5.59	5.50	4.52	4.06	3.22	2.92	
EBS	7-1/2	7.73	7.64	6.29	5.32	4.23	3.84	7.59	7.47	6.13	5.18	4.10	3.72	
EBS	10	9.51	9.64	7.28	6.77	5.62	4.71	9.35	9.43	7.10	6.59	5.46	4.57	
EBS	13	13.6	14.0	10.2	9.61	8.08	6.25	13.4	13.7	9.99	9.36	7.85	6.06	
O	9	9.66	9.25	7.28	6.16	5.37	4.50	9.48	9.04	7.09	5.99	5.21	4.36	
O	12	13.2	12.7	9.96	9.81	8.55	7.17	13.0	12.4	9.71	9.54	8.30	6.95	
O	21	21.3	20.4	14.4	11.8	10.2	8.60	21.0	20.0	14.0	11.4	9.95	8.32	
O	30	30.7	32.3	23.1	17.6	15.3	12.9	30.1	31.6	22.5	17.1	14.9	12.5	
O	35	35.6	37.5	26.8	19.1	16.7	14.0	34.9	36.6	26.1	18.6	16.2	13.5	
O	45	45.7	48.2	34.5	22.0	19.2	16.1	44.9	47.1	33.6	21.4	18.6	15.6	
V	38	38.6	39.5	33.8	33.5	30.8	24.5	37.9	38.6	32.9	32.6	29.9	23.7	
V	50	51.8	52.9	45.3	47.8	44.0	34.9	50.9	51.8	44.2	46.5	42.7	33.8	
V	70	71.2	72.7	63.0	66.9	61.5	48.9	69.9	71.0	61.4	65.1	59.8	47.4	
REPLACEABLE CARTRIDGE THERMOSTATIC EXPANSION VALVES														
Q-EQ-SQ	0	1/6	0.20	0.22	0.20	0.20	0.17	0.15	0.20	0.21	0.20	0.20	0.17	0.14
Q-EQ-SQ	1	1/4	0.46	0.49	0.46	0.45	0.39	0.33	0.45	0.48	0.45	0.44	0.38	0.32
Q-EQ-SQ	2	1/2	0.66	0.72	0.67	0.59	0.51	0.43	0.65	0.70	0.66	0.58	0.50	0.42
Q-EQ-SQ	3	1	1.02	1.07	0.89	0.86	0.74	0.62	1.00	1.05	0.88	0.83	0.72	0.60
Q-EQ-SQ	4	1-1/2	1.63	1.71	1.44	1.48	1.27	1.07	1.60	1.67	1.41	1.44	1.24	1.03
Q-EQ-SQ	5	2	2.14	2.25	1.88	1.97	1.70	1.43	2.10	2.20	1.84	1.92	1.65	1.38
Q-EQ-SQ	6	3	2.86	3.00	2.51	2.47	2.13	1.77	2.79	2.93	2.46	2.40	2.07	1.72
BQ-EBQ-SBQ	Balanced port replaceable cartridges, AAA, AA, A, B and C, have the same capacities as the matching nominal capacity of the standard balanced port valves above.													

REFRIGERANT	LIQUID TEMPERATURE ENTERING TEV °F														
	0°	10°	20°	30°	40°	50°	60°	70°	80°	90°	100°	110°	120°	130°	140°
402A	2.01	1.91	1.82	1.72	1.62	1.52	1.42	1.32	1.22	1.11	1.00	0.89	0.77	0.65	0.53
507	1.99	1.89	1.79	1.69	1.59	1.50	1.40	1.30	1.20	1.10	1.00	0.89	0.78	0.66	0.51

These factors include corrections for liquid refrigerant density and net refrigerating effect and are based on an evaporator temperature of 0°F. However, they may be used for any evaporator temperature from -40°F to 40°F since the variation in the actual factors across this range is insignificant.

EVAPORATOR TEMPERATURE °F	PRESSURE DROP ACROSS TEV (psi)										
	30	50	75	100	125	150	175	200	225	250	275
40°	0.55	0.71	0.87	1.00	1.12	1.22	1.32	1.41	1.50	1.58	1.66
20° & 0°	0.49	0.63	0.77	0.89	1.00	1.10	1.18	1.26	1.34	1.41	1.48
-10° & -20°	0.45	0.58	0.71	0.82	0.91	1.00	1.08	1.15	1.22	1.29	1.35
-40°	0.41	0.53	0.65	0.76	0.85	0.93	1.00	1.07	1.13	1.20	1.25

TEV Capacity = TEV Rating x CF Liquid Temperature x CF Pressure Drop — Example: Actual capacity of a nominal 1-1/2 ton R-404A Type EG valve at -20°F evaporator, 125 psi pressure drop across the TEV, and 60°F liquid temperature entering the TEV = 1.26 (from rating chart) x 1.43 (CF liquid temperature) x 0.91 (CF pressure drop) = 1.64 tons.

THERMOSTATIC EXPANSION VALVE CAPACITIES for REFRIGERANTS - TONS OF REFRIGERATION

134a, 401A, 409A

AIR CONDITIONING, HEAT PUMP and COMMERCIAL REFRIGERATION APPLICATIONS

VALVE TYPES	NOMINAL CAPACITY	REFRIGERANT								
		134a			401A			409A		
		RECOMMENDED THERMOSTATIC CHARGE								
		JC, JCP60			XC, XCP60			FC, FCP60		
EVAPORATOR TEMPERATURE °F										
40° 20° 0° 40° 20° 0° 40° 20° 0°										
F-EF-G-EG	1/8	0.15	0.15	0.14	0.16	0.16	0.15	0.15	0.15	0.14
F-EF-G-EG	1/6	0.25	0.28	0.26	0.27	0.30	0.29	0.25	0.28	0.27
F-EF-G-EG	1/4	0.31	0.35	0.33	0.34	0.37	0.36	0.32	0.35	0.33
F-EF-G-EG	1/2	0.60	0.60	0.55	0.65	0.65	0.60	0.61	0.60	0.56
F-EF-G-EG	1	1.20	1.20	1.10	1.29	1.29	1.20	1.21	1.21	1.12
F-EF-G-EG	1-1/2	1.93	1.91	1.76	2.07	2.07	1.92	1.94	1.93	1.79
F&E(Ext)-G&E(Ext)-S	2	2.41	2.39	2.20	2.59	2.59	2.40	2.42	2.42	2.23
S	2-1/2	3.01	2.99	2.75	3.23	3.24	3.00	3.03	3.02	2.79
S	3	3.62	3.59	3.30	3.88	3.88	3.60	3.63	3.62	3.35
S (Ext)	5	6.03	4.98	4.17	6.47	5.39	4.56	6.05	5.03	4.24
S (Ext)	6	7.23	5.98	5.01	7.76	6.47	5.47	7.26	6.04	5.09
H	3	3.62	3.59	3.04	3.88	3.88	3.31	3.63	3.62	3.08
H	4	4.82	4.79	4.05	5.18	5.18	4.42	4.84	4.83	4.11
H	5	6.03	5.98	5.06	6.47	6.47	5.52	6.05	6.04	5.14
H	8	9.04	8.97	7.59	9.70	9.71	8.29	9.08	9.06	7.71
H	12	14.1	14.0	11.8	15.1	15.1	12.9	14.2	14.1	12.0
M	15	18.7	18.5	15.1	20.1	20.1	16.5	18.8	18.7	15.3
M	20	24.1	23.9	19.5	25.9	25.9	21.3	24.2	24.2	19.8
M	25	30.1	29.9	24.3	32.3	32.4	26.6	30.3	30.2	24.7

BALANCED PORT THERMOSTATIC EXPANSION VALVES										
BF-EBF-SBF	AAA	0.25	0.28	0.26	0.27	0.30	0.29	0.25	0.28	0.27
BF-EBF-SBF	AA	0.54	0.54	0.50	0.58	0.58	0.54	0.55	0.54	0.50
BF-EBF-SBF	A	1.21	1.20	1.10	1.29	1.29	1.20	1.21	1.21	1.12
BF-EBF-SBF	B	2.05	2.03	1.87	2.20	2.20	2.04	2.06	2.05	1.90
BF-EBF-SBF	C	3.62	3.59	3.30	3.88	3.88	3.60	3.63	3.62	3.35
EBS	5	6.12	5.60	4.82	6.57	6.06	5.26	6.15	5.66	4.89
EBS	7	8.44	7.72	6.64	9.06	8.36	7.25	8.47	7.80	6.74
EBS	9	11.2	9.72	7.80	12.0	10.5	8.52	11.2	9.81	7.92
EBS	12	16.0	14.0	10.9	17.2	15.1	11.9	16.1	14.1	11.1
O	9	10.8	10.8	9.33	11.6	11.7	10.2	10.9	10.9	9.48
O	12	14.1	14.0	12.1	15.1	15.1	13.2	14.2	14.1	12.3
O	16	18.7	18.5	16.1	20.1	20.1	17.6	18.8	18.7	16.3
O	23	27.7	30.0	24.7	29.8	32.4	27.0	27.8	30.2	25.1
O	32	38.6	41.7	34.4	41.4	45.1	37.6	38.7	42.1	34.9
O	40	48.2	52.1	43.0	51.8	56.4	47.0	48.4	52.6	43.7
V	35	42.2	41.9	33.2	45.3	45.3	36.3	42.4	42.3	33.7
V	45	54.2	53.8	42.7	58.2	58.3	46.6	54.5	54.3	43.3
V	55	66.3	65.8	52.2	71.2	71.2	57.0	66.6	66.4	53.0
W	80	102	102	75.3	110	110	82.2	103	103	76.4
W	110	137	—	—	148	—	—	138	—	—

VALVE TYPES	CARTRIDGE NO.	REPLACEABLE CARTRIDGE THERMOSTATIC EXPANSION VALVES								
Q-EQ-SQ	0	1/6	0.24	0.24	0.22	0.26	0.26	0.24	0.24	0.22
Q-EQ-SQ	1	1/4	0.54	0.54	0.50	0.58	0.58	0.54	0.55	0.54
Q-EQ-SQ	2	1/2	0.78	0.78	0.72	0.84	0.84	0.78	0.79	0.73
Q-EQ-SQ	3	1	1.21	1.20	1.10	1.29	1.29	1.20	1.21	1.12
Q-EQ-SQ	4	1-1/2	1.69	1.67	1.54	1.81	1.81	1.68	1.69	1.56
Q-EQ-SQ	5	2	2.41	2.39	2.20	2.59	2.59	2.40	2.42	2.23
Q-EQ-SQ	6	2-1/2	3.25	3.23	2.97	3.49	3.50	3.24	3.27	3.02

BQ-EBQ-SBQ Balanced port replaceable cartridges, AAA, AA, A, B and C, have the same capacities as the matching nominal capacity of the standard balanced port valves above.







REFRIGERANT	LIQUID TEMPERATURE ENTERING TEV °F														
	0°	10°	20°	30°	40°	50°	60°	70°	80°	90°	100°	110°	120°	130°	140°
134a	1.70	1.63	1.56	1.49	1.42	1.36	1.29	1.21	1.14	1.07	1.00	0.93	0.85	0.78	0.71
401A	1.60	1.54	1.48	1.43	1.36	1.31	1.25	1.19	1.13	1.06	1.00	0.94	0.87	0.80	0.74
409A	1.55	1.50	1.45	1.39	1.34	1.28	1.23	1.17	1.12	1.06	1.00	0.94	0.88	0.82	0.76

These factors include corrections for liquid refrigerant density and net refrigerating effect and are based on an evaporator temperature of 0°F. However, they may be used for any evaporator temperature from 0°F to 40°F since the variation in the actual factors across this range is insignificant.



EVAPORATOR TEMPERATURE °F	PRESSURE DROP ACROSS TEV (psi)							
	20	40	60	80	100	120	140	160
40°	0.58	0.82	1.00	1.15	1.29	1.41	1.53	1.63
20° & 0°	0.50	0.71	0.87	1.00	1.12	1.22	1.32	1.41

TEV Capacity = TEV Rating x CF Liquid Temperature x CF Pressure Drop — Example: Actual capacity of a nominal 1-1/2 ton R-134a Type EG valve at 20°F evaporator, 100 psi pressure drop across the TEV, and 60°F liquid temperature entering the TEV = 1.91 (from rating chart) x 1.29 (CF liquid temperature) x 1.12 (CF pressure drop) = 2.76 tons.





▼ TEV QUICK REFERENCE GUIDE

VALVE TYPE	SPECS	NOMINAL CAPACITY RANGE (Tons)				CONNECTION TYPES	VALVE DESCRIPTION AND APPLICATION
		R-22	R-134a	R-404A & R-507	R-410A		
RC 	Page 12	1 thru 6	–	–	1 thru 6	Chatleff, SAE Flare, or ODF Solder	Small brass body, externally adjustable valve available for R-22 and R-410A air conditioning and heat pump applications. This valve features a balanced port construction and contains an internal check valve to eliminate the need for an external bypass check valve on heat pump applications. Suitable for replacing OEM type TEVs with or without internal check valve on these applications. Inlet strainer is not included.
ER 	Page 13	1 thru 12	–	–	1 thru 15	ODF Solder	Small brass body, externally adjustable valve available for R-22 and R-410A air conditioning and heat pump applications. This valve features a balanced port construction and is approved for bi-directional operation. Suitable for replacing OEM type TEVs without internal check valve on these applications. A 60 x 50 mesh inlet strainer is included with 3/8" inlet.
F 	Page 15 - 16	1/5 thru 3	1/8 thru 2	1/8 thru 2	–	SAE Flare	Small brass bar body, externally adjustable valve for small capacity refrigeration systems. SAE flare inlet connection has a removable 100 mesh strainer. Typical applications: Refrigerated cases, coolers, freezers.
EF 	Page 15 - 16	1/5 thru 3	1/8 thru 2	1/8 thru 2	–	ODF Solder	Same as the Type F valve except valve features ODF solder connections. The inlet connection has a 60 x 50 mesh insert type strainer. Typical applications: Refrigerated cases, coolers, freezers.
Q/BQ 	Page 17 - 21	Q 1/3 thru 5 BQ 1/8 thru 5-1/2	Q 1/6 thru 2-1/2 BQ 1/8 thru 3	Q 1/6 thru 3 BQ 1/8 thru 3	Q – BQ 1/4 thru 6	SAE Flare	The brass body Type Q valve is externally adjustable with a removable cartridge or orifice. The valve body, cartridge and thermostatic element is supplied as independent components. This allows body, cartridge and element to be assembled and matched to specific system requirements. Inlet connection has a 100 mesh removable strainer screen. Typical applications: Refrigeration applications and external equalized versions may be used on air conditioning. Type BQ same as above, with balanced port construction.
EQ/EBQ 	Page 17 - 21	EQ 1/3 thru 5 EBQ 1/8 thru 5-1/2	EQ 1/6 thru 2-1/2 EBQ 1/8 thru 3	EQ 1/6 thru 3 EBQ 1/8 thru 3	EQ – EBQ 1/4 thru 6	Extended ODF Solder	Type EQ same as the Type Q except it features extended ODF connections. A 100 mesh insert strainer is provided with the valve. Type EBQ same as Type EQ with balanced port construction and is approved for bi-directional applications.
SQ/SBQ 	Page 17 - 21	SQ 1/3 thru 5 SBQ 1/8 thru 5-1/2	SQ 1/6 thru 2-1/2 SBQ 1/8 thru 3	SQ 1/6 thru 3 SBQ 1/8 thru 3	SQ – SBQ 1/4 thru 6	Extended ODF Solder	Type SQ same as the Type Q valve except it features ODF solder connections and a forged brass inlet fitting with a removable 100 mesh strainer screen which can be cleaned and/or replaced without removing the valve from the line. Type SBQ is the same as Type SQ with balanced port construction and is approved for bi-directional applications.

▼ TEV QUICK REFERENCE GUIDE

VALVE TYPE	SPECS	NOMINAL CAPACITY RANGE (Tons)				CONNECTION TYPES	VALVE DESCRIPTION AND APPLICATION
		R-22	R-134a	R-404A & R-507	R-410A		
G 	Page 22	1/5 thru 3	1/8 thru 2	1/8 thru 2	–	SAE Flare	Forged brass body, externally adjustable valve for small capacity refrigeration systems. Inlet connection has a removable 100 mesh strainer. Typical applications: Refrigerated cases, coolers, freezers, small capacity air conditioners.
EG 	Page 23	1/5 thru 3	1/8 thru 2	1/8 thru 2	–	ODF Solder	Same as the Type G valve except it features ODF solder connections and a forged brass inlet fitting with a removable 100 mesh strainer which can be cleaned and/or replaced without removing the valve from the line.
BF 	Page 24	1/8 thru 5-1/2	1/8 thru 3	1/8 thru 3	–	SAE Flare	Same physical size as the Type F valve with SAE flare connections except it features a balanced port construction. Inlet connection has a removable 100 mesh strainer. Typical applications: Small capacity refrigeration that operates over widely varying operating conditions.
SBF 	Page 25 - 26	1/8 thru 5-1/2	1/8 thru 3	1/8 thru 3	–	Extended ODF Solder	Same as the Type BF valve except it features ODF solder connections and a forged brass inlet fitting with a removable 100 mesh strainer which can be cleaned and/or replaced without removing the valve from the line.
EBF 	Page 25 - 26	1/8 thru 5-1/2	1/8 thru 3	1/8 thru 3	–	Extended ODF Solder	Same as the Type BF valve except it features extended ODF connections. A 100 mesh insert strainer is provided with the valve.
S 	Page 27	2 thru 10	2 thru 6	2 thru 7	–	ODF Solder	Brass bar body, externally adjustable valve. Inlet has a permanent 12 mesh strainer. General purpose valve for air conditioning and refrigeration applications.
EBS 	Page 28	8 thru 20	5 thru 12	6 thru 13	–	Extended ODF Solder	Same physical size as the Type S valve except it features extended ODF connections. This valve features a balanced port construction which, depending on its capacity, makes it suitable for bi-directional operation. See page 28 for details.

▼ TEV QUICK REFERENCE GUIDE

VALVE TYPE	SPECS	NOMINAL CAPACITY RANGE (Tons)				CONNECTION TYPES	VALVE DESCRIPTION AND APPLICATION
		R-22	R-134a	R-404A & R-507	R-410A		
O 	Page 29 - 30	15 thru 70	9 thru 40	9 thru 45	20 thru 60	ODF Solder	Brass bar body, externally adjustable valve. Inlet has a permanent 12 mesh strainer. This valve features a balanced port construction, and it is suitable for both air conditioning and refrigeration applications. Optional bi-directional feature available, please contact Sporlan Division of Parker for details.
H 	Page 31	5-1/2 thru 20	3 thru 12	3 thru 12	–	ODF Solder or FPT Flange	Brass bar body, externally adjustable valve with flange connections. Inlet flange bushing has a permanent 16 mesh strainer. The FPT flange connection requires the K-1178 adapter kit. This valve provides the smallest capacity TEVs with flange connections and it is suitable for both air conditioning and refrigeration applications.
M 	Page 32	21 thru 42	15 thru 25	15 thru 30	–	ODF Solder or FPT Flange	Cast bronze body, externally adjustable valve with flange connections. Inlet has a 12 mesh strainer. This valve type provides valve capacities greater than the Type H and it is suitable for air conditioning and refrigeration applications. Flanges for the Type M valve are interchangeable with the Type V valve.
V 	Page 33	52 thru 100	35 thru 55	38 thru 70	–	ODF Solder or FPT Flange	Cast bronze body, externally adjustable valve with flange connections. Inlet has a 12 mesh strainer. This valve type features a dual port semi-balanced design. This valve type provides valve capacities greater than the Type M and is suitable for air conditioning and refrigeration applications. Flanges for the Type V are interchangeable with the Type M.
W 	Page 34	135 & 180	80 & 110	–	–	ODF Solder Flange	Cast bronze body, externally adjustable valve with flange connections. Inlet has a 12 mesh strainer. This valve type features a dual port semi-balanced design and it is primarily for large capacity chillers. This valve type provides the largest valve capacities available for flange connection TEVs.

▼ TYPE RC

For Refrigerants 22, 410A
Chatleff, SAE Flare & ODF Solder Connections

Sporlan Type RC valve is a small brass body, externally adjustable valve with balanced port construction. The RC valves are available for replacement of types CBI and CBBI valves. These valves contain internal check valves to allow reverse flow on heat pump applications. This eliminates the need for an external check valve piped around the TEV for reverse flow. The RC valve can be used on heat pump and air conditioning (cooling only) applications. This allows you to reduce inventory by using the same valve

to replace the I, BI and BBI valves. The RC valves can even be used to replace the RI valve (non-RPB versions only).

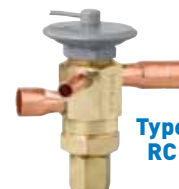

Outlet Connections
1/2" SAE, 1/2" ODF, 5/8" ODF

Mating Distributors (See Bulletin 20-10)
D260, D262, 1603, 1605, 1606, 1608, 1620, 1622, 1650(R), 1651(R)

For complete details of construction, see page 35.

SPECIFICATIONS ELEMENT SIZE NO. 43 (R-22) AND NO. 45 (R-410A), KNIFE EDGE JOINT

REFRIGERANT (Sporlan Code)	VALVE TYPE	EXTERNAL EQUALIZER ②, ③	NOMINAL CAPACITY Tons of Refrigeration	THERMOSTATIC ELEMENT SIZE NO.	THERMOSTATIC CHARGES AVAILABLE	STANDARD TUBING LENGTH	CONNECTIONS - Inches ① SAE Flare/ ④ ODF Solder <i>Blue figures are standard and will be furnished unless otherwise specified.</i>		NET WEIGHT	SHIPPING WEIGHT
							INLET	OUTLET		
22 (V) 407C (N) 407A (V) 422D (V)	RCVE-1-GA	1/4 SAE 1/4 ODF	1	43	VGA	30 in. 760 mm	3/8 SAE 3/8 ODF	1/2 SAE	1-1/4 lbs. 568 g	1-1/2 lbs. 680 g
	RCVE-1-1/2-GA		1-1/2					1/2 ODF		
	RCVE-2-GA		2					1/2 SAE		
	RCVE-3-GA		3					1/2 ODF		
	RCVE-4-GA		4					1/2 SAE		
	RCVE-5-GA		5					1/2 ODF		
RCVE-6-GA	6	5/8 ODF								
410A (Z)	RCZE-1-GA	1/4 ODF	1	45	ZGA	30 in. 760 mm	3/8 ODF	1/2 ODF	1-1/4 lbs. 568 g	1-1/2 lbs. 680 g
	RCZE-1-1/2-GA		1-1/2					1/2 ODF		
	RCZE-2-GA		2					1/2 SAE		
	RCZE-3-GA		3					1/2 ODF		
	RCZE-4-GA		4					1/2 SAE		
	RCZE-5-GA		5					1/2 ODF		
RCZE-6-GA	6	5/8 ODF								

① Valves are also available as special order with Chatleff connections.
 ② Valves with SAE inlet and outlet fittings are available only with the 1/4" SAE flare external equalizer; valves with ODF fittings are available only with the 1/4" ODF external equalizer.
 ③ Valves with Chatleff fittings are available only with the 1/8" OD X 24" long tube with flare and nut external equalizer.
 ④ ODF Solder on Type RC valves indicates a female connection on the valve of proper diameter to receive copper tubing of corresponding OD size. Thus 1/2" ODF will receive 1/2" OD tubing.

DIMENSIONS

CONNECTIONS - Inches

VALVE TYPE	FITTING SIZE	A	B	C	D
RC	3/8 SAE	1.92	-	-	1.63
	1/2 SAE	1.89	1.92	-	1.63
	3/8 ODF	1.92	1.45	0.31	1.90
	1/2 ODF	1.98	1.45	0.40	1.90
	5/8 ODF	-	1.53	0.50	1.90
RC Chatleff Fitting		1.89	1.71	-	③

BULB SIZES - Inches

STANDARD CHARGES	REFRIGERANT	
	22	410A
GA	0.75 OD x 2.00	

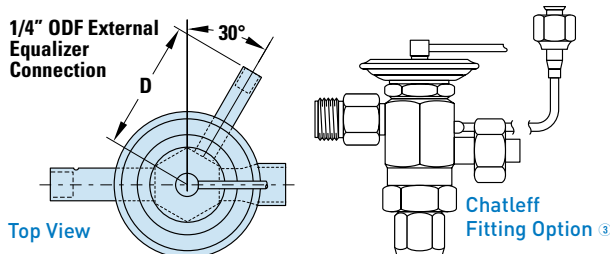
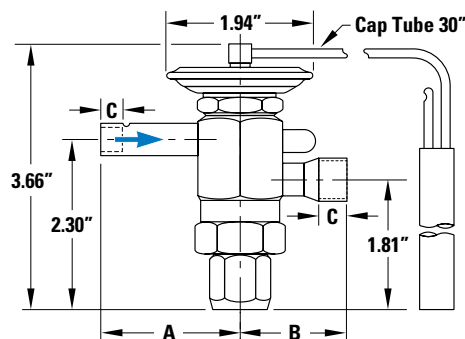

▼ TYPE ER

For Refrigerants 22, 410A
ODF Solder Connections

Sporlan Type ER valve is a small brass bar body, externally adjustable with ODF solder connections, a replaceable thermostatic element, and balanced port construction. The ER valve is designed for R-22 and R-410A air conditioning and heat pump applications and is ideal for replacing I, BI, BBI and RI (non-RPB version only) valves.

This valve type has two body styles: a small body which provides capacities up to 8 tons R-22 and R-410A, and a large body style which extends capacities to 12 tons R-22 and 15 tons R-410A.

Replacement elements available for these valves are the following: Refrigerant 22, Element Kit Number KT-43-VGA or VCP100 for the small

body style and KT-45-5-VGA or VCP100 for the large body, and Refrigerant 410A, Element Kit Number KT-45-ZGA or ZCP180 for the small body style and KT-45-5-ZGA or ZCP180 for the large body style.

This valve may also be applied in bi-directional applications.

Outlet Connections

1/2" ODF, 5/8" ODF, 7/8" ODF, 1-1/8" ODF

Mating Distributors (See Bulletin 20-10)

D260, D262, 1620, 1622, 1112, 1113, 1115, 1116, 1135, 1136, 1137, 1651(R), 1653(R), 1655(R)

For complete details of construction, see page 35.

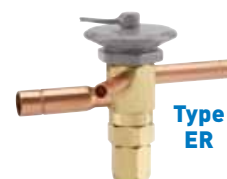

SPECIFICATIONS ELEMENT SIZE NO. 43 (R-22), NO. 45 (R-410A), AND NO. 45-5, KNIFE EDGE JOINT

REFRIGERANT (Sporlan Code)	VALVE TYPE	NOMINAL CAPACITY Tons of Refrigeration	THERMOSTATIC ELEMENT SIZE NO.	THERMOSTATIC CHARGES AVAILABLE	STANDARD TUBING LENGTH	CONNECTIONS -Inches ① ODF Solder Not all connection combinations are available.		NET WEIGHT	SHIPPING WEIGHT	
						INLET	OUTLET			
22 (V) 407C (N) 407A (V) 422D (V)	ERVE-1	1	43	VGA VCP100	60 in. 1.5 m	3/8	1/2	1 lb. 454 g	1-1/2 lbs. 680 g	
	ERVE-1-1/2	1-1/2					3/8 or 1/2			1/2 or 5/8
	ERVE-2	2								1/2, 5/8 or 7/8
	ERVE-3	3				1/2	5/8 or 7/8			
	ERVE-4	4					7/8			
	ERVE-5	5				5/8				
	ERVE-6	6	45-5	ZGA ZCP180	60 in. 1.5 m		3/8	1/2	1 lb. 454 g	1-1/2 lbs. 680 g
	ERVE-8	8				3/8 or 1/2		1/2 or 5/8		
	ERVE-10	10	1/2	1/2, 5/8 or 7/8						
	ERVE-12	12		7/8						
	410A (Z)	ERZE-1	1		45	ZGA ZCP180	60 in. 1.5 m	3/8	1/2	1 lb. 454 g
		ERZE-1-1/2	1-1/2	3/8 or 1/2					1/2 or 5/8	
ERZE-2		2	1/2, 5/8 or 7/8							
ERZE-3		3	1/2	5/8 or 7/8						
ERZE-4		4		7/8						
ERZE-5		5	5/8					45-5	ZGA ZCP180	
ERZE-6		6		3/8 or 1/2	1/2 or 5/8					
ERZE-8		8	1/2		1/2, 5/8 or 7/8					
ERZE-12-1/2		12-1/2		7/8						
ERZE-15		15	1-1/8							

① ODF Solder indicates a female connection on the valve of proper diameter to receive copper tubing of corresponding OD size. Thus 1/2" ODF will receive 1/2" OD tubing.

▼ TYPE ER

For Refrigerants 22, 410A
ODF Solder Connections

TYPE ER with NUMBER 43 and 45 ELEMENT

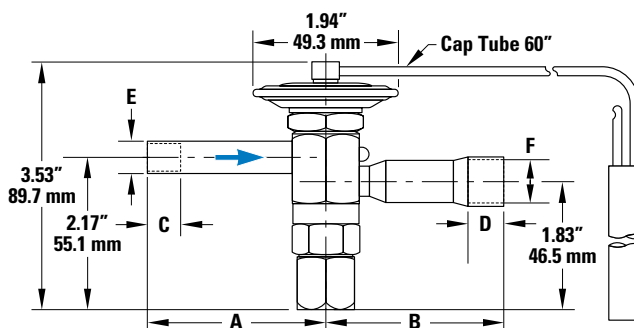
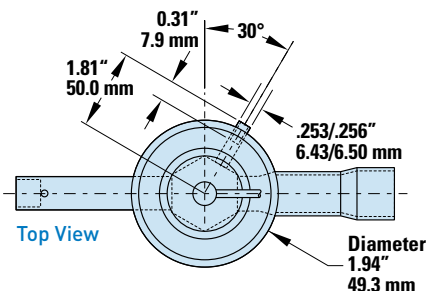

DIMENSIONS - CONNECTIONS

REFRIGERANT	NOMINAL CAPACITY	FITTING SIZE		A	B	C	D	E	F		
		INLET	OUTLET								
22 410A	1-1/2	3/8"	1/2"	2.42"	2.51"	0.31"	0.40"	.377/.381"	.502/.506"		
	2			61.5 mm	63.8 mm	7.9 mm	10.2 mm	9.58/9.68 mm	12.8/12.9 mm		
	3			1/2"	5/8"	2.35"	2.51"	0.40"	0.50"	.502/.506"	.627/.632"
	4					59.7 mm	63.8 mm		12.7 mm		15.9/16.1 mm
	5					7/8"	2.41"	61.2 mm	19.8 mm		.877/.882"
	6	5/8"	7/8"	2.35"	2.41"		0.50"	0.78"	.877/.882"		
	8			59.7 mm	61.2 mm		12.7 mm	19.8 mm	22.3/22.4 mm		
	6	5/8"	7/8"	2.35"	2.41"	0.50"	0.78"	.627/.632"	.877/.882"		
	8						19.8 mm		22.3/22.4 mm		
	8	5/8"	1-1/8"	2.35"	2.41"	0.50"	0.91"	15.9/16.1 mm	1.128/1.135"		
	8						23.1 mm		28.7/28.8 mm		

BULB SIZES

STANDARD CHARGES	REFRIGERANT	
	22	410A
VCP100, ZCP180	0.50" OD x 3.00"	12.7 mm x 76.2 mm
GA	0.75" OD x 2.00"	19.1 mm x 50.8 mm

TYPE ER with NUMBER 45-5 ELEMENT

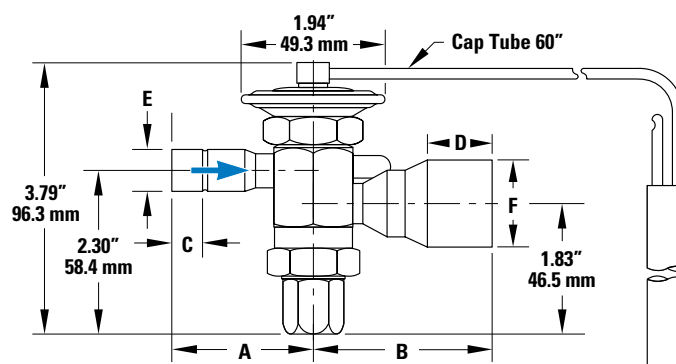
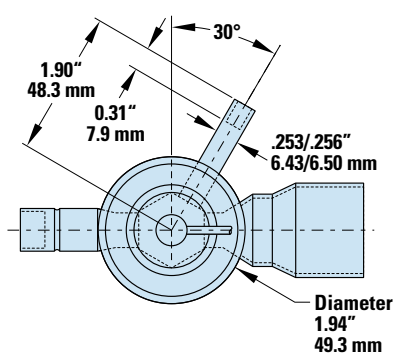

DIMENSIONS - CONNECTIONS

REFRIGERANT	NOMINAL CAPACITY	FITTING SIZE		A	B	C	D	E	F
		INLET	OUTLET						
22	10 12	5/8"	7/8"	2.48"	2.51"	0.50"	0.78"	.627/.632"	.877/.882"
410A	12-1/2 15		1-1/8"	63.0 mm	63.8 mm	12.7 mm	19.8 mm		15.9/16.1 mm
410A	12-1/2 15	5/8"	1-1/8"	63.0 mm	63.8 mm	12.7 mm	0.91"	15.9/16.1 mm	1.128/1.135"
410A	12-1/2 15		23.1 mm	28.7/28.8 mm					

▼ TYPE F & EF

For Refrigerants 22, 134a, 404A, 507
SAE Flare & ODF Solder Connections

Sporlan Type F with SAE flare connections or Type EF with ODF solder connections are small brass bar body valves with identical internal construction and replaceable thermostatic elements. The Type F valve has a removable 100 mesh strainer as a standard feature. The Type EF has a 60 x 50 mesh insert strainer. These valves are designed for small refrigeration systems such as refrigerated cases, coolers, and

freezers where space is limited and an external adjustment is desired.

Outlet Connections

3/8" SAE, 1/2" SAE, 3/8" ODF, 1/2" ODF

Mating Distributors (See Bulletin 20-10)

D260, D262, 1603, 1605, 1606, 1608, 1650(R)

For complete details of construction, see page 35.

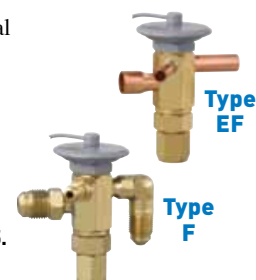

SPECIFICATIONS ELEMENT SIZE NO. 43, KNIFE EDGE JOINT

REFRIGERANT (Sporlan Code)	TYPE F		TYPE EF		NOMINAL CAPACITY Tons of Refrigeration	THERMOSTATIC CHARGES AVAILABLE	STANDARD TUBING LENGTH	CONNECTIONS - Inches SAE Flare / Ⓣ ODF Solder		NET WEIGHT	SHIPPING WEIGHT
	Internal Equalizer	External Equalizer	Internal Equalizer	External Equalizer				Blue figures are standard and will be furnished unless otherwise specified.			
								INLET	OUTLET		
22 (V) 407C (N) 407A (V) 422D (V)	FV-1/5	FVE-1/5	EFV-1/5	EFVE-1/5	1/5	C Z ZP40	30 in. 760 mm	1/4 or 3/8 Ⓣ	3/8 or 1/2	1 lb. 454 g	1-1/2 lbs. 680 g
	FV-1/3	FVE-1/3	EFV-1/3	EFVE-1/3	1/3						
	FV-1/2	FVE-1/2	EFV-1/2	EFVE-1/2	1/2						
	FV-1	FVE-1	EFV-1	EFVE-1	1						
	FV-1-1/2	FVE-1-1/2	EFV-1-1/2	EFVE-1-1/2	1-1/2						
	—	FVE-2	—	EFVE-2	2						
	FV-2-1/2	—	EFV-2-1/2	—	2-1/2						
—	—	—	EFVE-3	3							
134a (J) 12 (F) 401A (X) 409A (F)	FJ-1/8	FJE-1/8	EFJ-1/8	EFJE-1/8	1/8	C	30 in. 760 mm	1/4 or 3/8 Ⓣ	3/8 or 1/2	1 lb. 454 g	1-1/2 lbs. 680 g
	FJ-1/6	FJE-1/6	EFJ-1/6	EFJE-1/6	1/6						
	FJ-1/4	FJE-1/4	EFJ-1/4	EFJE-1/4	1/4						
	FJ-1/2	FJE-1/2	EFJ-1/2	EFJE-1/2	1/2						
	FJ-1	FJE-1	EFJ-1	EFJE-1	1						
	FJ-1-1/2	FJE-1-1/2	EFJ-1-1/2	EFJE-1-1/2	1-1/2						
	—	FJE-2	—	EFJE-2	2						
404A (S) 502 (R) 408A (R)	FS-1/8	FSE-1/8	EFS-1/8	EFSE-1/8	1/8	C Z ZP40	30 in. 760 mm	1/4 or 3/8 Ⓣ	3/8 or 1/2	1 lb. 454 g	1-1/2 lbs. 680 g
	FS-1/6	FSE-1/6	EFS-1/6	EFSE-1/6	1/6						
	FS-1/4	FSE-1/4	EFS-1/4	EFSE-1/4	1/4						
	FS-1/2	FSE-1/2	EFS-1/2	EFSE-1/2	1/2						
	FS-1	FSE-1	EFS-1	EFSE-1	1						
	FS-1-1/2	FSE-1-1/2	EFS-1-1/2	EFSE-1-1/2	1-1/2						
	—	FSE-2	—	EFSE-2	2						
507 (P) 402A (L)	FP-1/8	FPE-1/8	EFP-1/8	EFPE-1/8	1/8	C Z ZP40	30 in. 760 mm	1/4 or 3/8 Ⓣ	3/8 or 1/2	1 lb. 454 g	1-1/2 lbs. 680 g
	FP-1/6	FPE-1/6	EFP-1/6	EFPE-1/6	1/6						
	FP-1/4	FPE-1/4	EFP-1/4	EFPE-1/4	1/4						
	FP-1/2	FPE-1/2	EFP-1/2	EFPE-1/2	1/2						
	FP-1	FPE-1	EFP-1	EFPE-1	1						
	FP-1-1/2	FPE-1-1/2	EFP-1-1/2	EFPE-1-1/2	1-1/2						
	—	FPE-2	—	EFPE-2	2						

Ⓣ The 3/8" SAE inlet fitting has a long taper on the flare surface. A 3/8" x 1/4" reducing flare nut will allow 1/4" OD tubing to be attached to this fitting.

Ⓣ ODF Solder on Type EF valves indicates a female connection on the valve of proper diameter to receive copper tubing of corresponding OD size. Thus 1/2" ODF will receive 1/2" OD tubing.

Ⓣ Nominal 1 ton and larger F valves for R-134a, R-404A and R-507 type refrigerants, and nominal 1-1/2 ton and larger for R-22 refrigerant require 3/8" SAE Flare or 3/8" ODF inlet, minimum.

▼ TYPE F & EF

For Refrigerants 22, 134a, 404A, 507
SAE Flare & ODF Solder Connections

SAE FLARE

DIMENSIONS

SAE CONNECTIONS - Inches

FITTING SIZE	A	B	C
1/4 SAE Elbow	1.05	—	1.34
3/8 SAE Elbow	1.27	—	0.98
3/8 SAE	—	1.61	—
1/2 SAE	—	1.80	—

BULB SIZES - Inches

STANDARD CHARGES	REFRIGERANT			
	22	134a	404A	507
C	0.50 OD x 3.00			
Z & ZP Series	0.50 OD x 3.00	—	0.50 OD x 3.00	

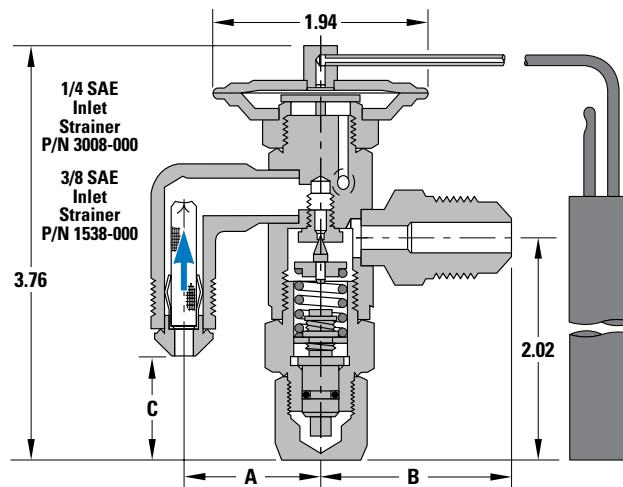
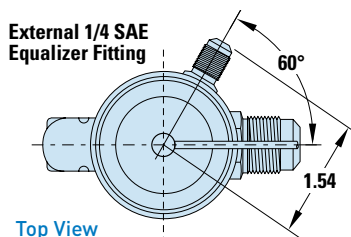

ODF SOLDER

DIMENSIONS

ODF CONNECTIONS - Inches

FITTING SIZE	A	B	C
1/4 ODF	1.69	—	0.31
3/8 ODF	1.69	1.35	0.31
1/2 ODF	—	1.35	0.40

BULB SIZES - Inches

STANDARD CHARGES	REFRIGERANT			
	22	134a	404A	507
C	0.50 OD x 3.00			
Z & ZP Series	0.50 OD x 3.00	—	0.50 OD x 3.00	

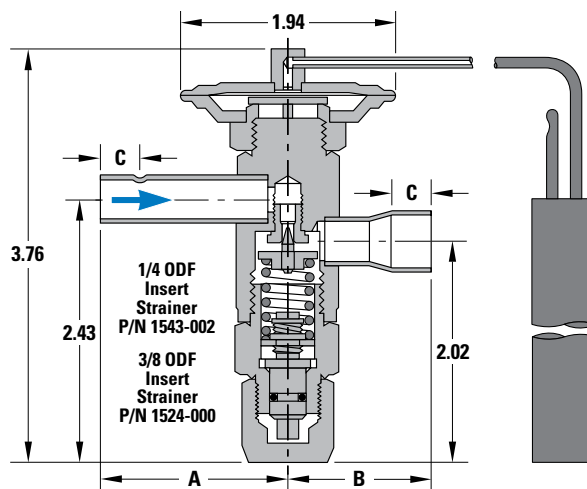
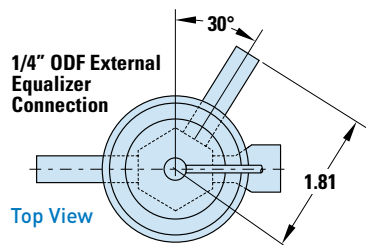

▼ TYPE Q & BQ

For Refrigerants 22, 134a, 404A, 410A*, 507
SAE Flare & Extended ODF Solder Connections

*Type Q, EQ, and SQ are not approved for R-410A applications.

The Sporlan Q & BQ series are replaceable cartridge style valves designed for small refrigeration systems, such as refrigerated cases, coolers, and freezers. The externally equalized versions of these valves are ideal for air conditioning and heat pump systems. BQ valves are balanced ported, engineered specifically for systems with a wide range of operating conditions and may be applied on bi-directional applications.

Q & BQ valves are supplied as three individual component parts: the **thermostatic element**, the **valve body**, and the **replaceable cartridge** or orifice. The interchangeable nature of the Q & BQ family make it ideal for reducing inventory, while increasing valve options — so, the right valve is always on hand.

BODY FEATURES

Q & BQ brass body type valves feature Sporlan's traditional knife edge, metal-to-metal thermostatic element to valve body construction, which ensures a leak-proof joint.

SELECTIVE CHARGES

Sporlan selective thermostatic charges are specifically designed for low temperature, medium temperature, and air conditioning applications. The elements are manufactured with a large flat diaphragm to reduce diaphragm stresses and provide precise control. And, because Q & BQ valve bodies and thermostatic elements are supplied as independent components, the installer is able to select the best possible thermostatic charge for the application.

INTERNAL PORT DESIGN

Refrigerant flow through the valve port opposes the pin movement in all type Q and BQ valves. This provides improved stability at light loads, when the pin modulates to a position close to the port. Additionally, charge migration, is reduced or eliminated by the Q & BQ valve design. By engineering the liquid flow to enter through the top of the valve body, the liquid refrigerant warms the thermostatic element and minimizes the potential for charge migration.

For complete details of construction, see page 35.

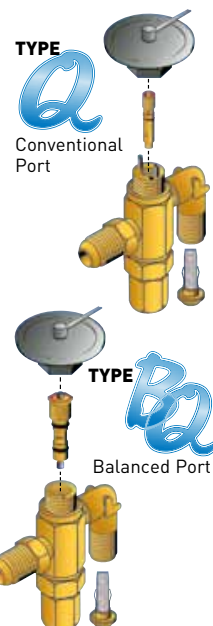

SELECTING COMPONENTS

BODY

Flare Connections

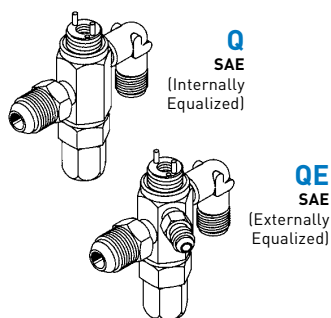

Extended Solder Connections

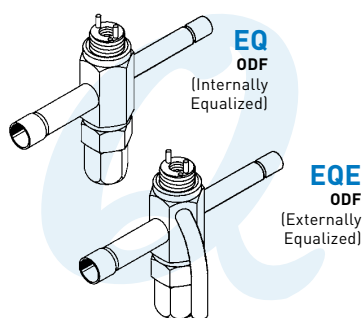

Extended Solder Connections with Forged Inlet and Replaceable Strainer

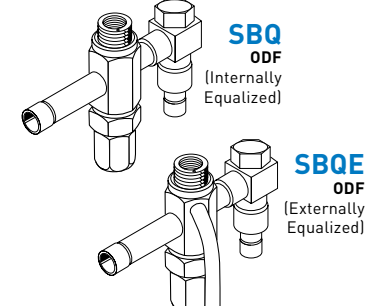
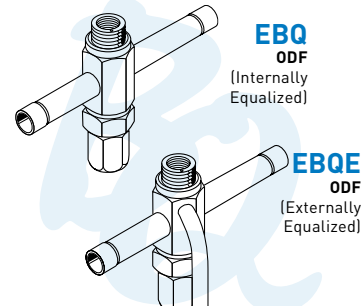
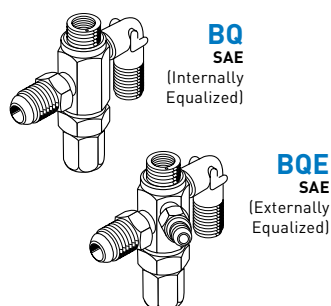
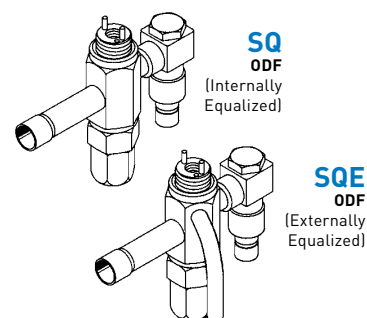

▼ TYPE Q & BQ

For Refrigerants 22, 134a, 404A, 410A*, 507
SAE Flare & Extended ODF Solder Connections

*Type Q, EQ, and SQ are not approved for R-410A applications.

CARTRIDGE

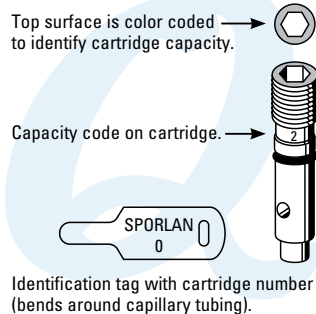

Q CARTRIDGE SERVICE KIT PART NUMBER 184000

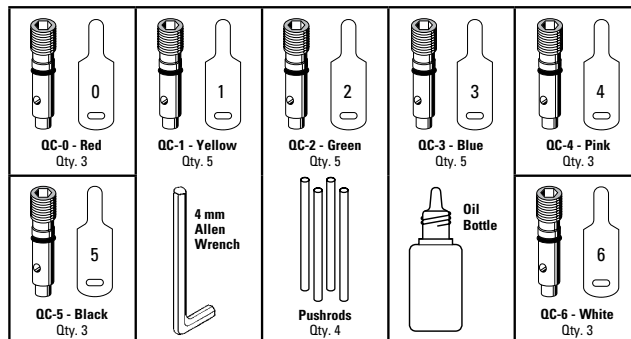

INDIVIDUAL REPLACEMENT PARTS

PART NUMBER	SIZE	COLOR CODE
CARTRIDGE and I.D. TAG		
QC-0	0	Red
QC-1	1	Yellow
QC-2	2	Green
QC-3	3	Blue
QC-4	4	Pink
QC-5	5	Black
QC-6	6	White
MISCELLANEOUS PARTS		
OB-1	Oil Bottle (With Oil)	
AW-1	4 mm Allen Wrench	
CSK-1	Q Cartridge Service Kit (Empty)	
184000	Q Cartridge Service Kit (Complete as noted above)	

CAPACITIES

NOMINAL CAPACITY (TONS) of SPORLAN VALVE TO BE REPLACED									Q VALVE CARTRIDGE	
R-12	R-22, R-422D	R-134a	R-401A	R-402A	R-404A	R-410A	R-502	R-507	SIZE	COLOR CODE
1/8	1/4	1/8	1/8	1/8	1/8	NOT APPROVED	1/8	1/8	0	Red
1/6	1/3	1/6	1/6	1/6	1/6		1/6	1/6		
1/4	1/2	1/4	1/4	1/4	1/4		1/4	1/4	1	Yellow
1/2	1	1/2	1/2	1/2	1/2		1/2	1/2	2	Green
1	1-1/2	1	1	1	1		1	1	3	Blue
1-1/2	2	1-1/2	1-1/2	1-1/2	1-1/2		1-1/2	1-1/2	4	Pink
2	3	2	2	2	2		2	2	5	Black
2-1/2	4	2-1/2	2-1/2	3	3		3	3	6	White
3	5	3	3							

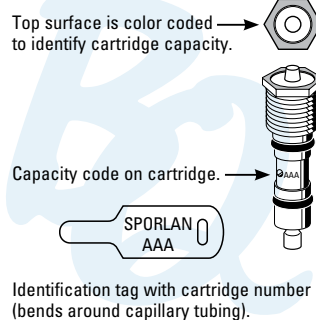

BQ CARTRIDGE SERVICE KIT PART NUMBER 184007

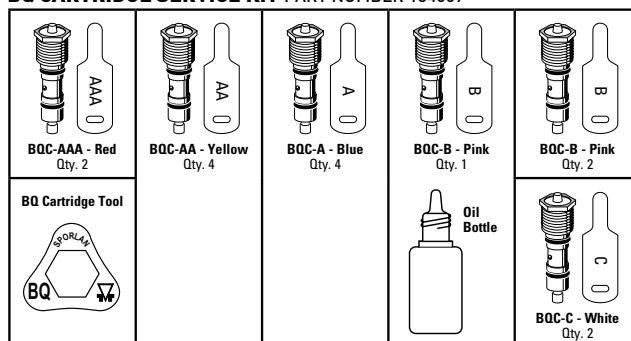

INDIVIDUAL REPLACEMENT PARTS

PART NUMBER	SIZE	COLOR CODE
CARTRIDGE and I.D. TAG*		
BQC-AAA	AAA	Red
BQC-AA	AA	Yellow
BQC-A	A	Blue
BQC-B	B	Pink
BQC-C	C	White
MISCELLANEOUS PARTS		
OB-1	Oil Bottle (With Oil)	
4444-000	BQ Cartridge Tool	
CSK-1	BQ Cartridge Service Kit (Empty)	
184007	BQ Cartridge Service Kit (Complete as noted above)	

CAPACITIES

NOMINAL CAPACITY (TONS) of SPORLAN VALVE TO BE REPLACED									BQ VALVE CARTRIDGE	
R-12	R-22, R-422D	R-134a	R-401A	R-402A	R-404A	R-410A	R-502	R-507	SIZE	COLOR CODE
1/8 thru 1/5	1/8 thru 1/3	1/8 thru 1/5	1/8 thru 1/5	1/8 thru 1/5	1/8 thru 1/5	1/4 thru 1/3	1/8 thru 1/5	1/8 thru 1/5	AAA	Red
1/4 thru 1/3	1/2 thru 2/3	1/4 thru 1/3	1/4 thru 1/3	1/4 thru 1/3	1/4 thru 1/3	1/2 thru 3/4	1/4 thru 1/3	1/4 thru 1/3	AA	Yellow
1/2 thru 1	3/4 thru 1-1/2	1/2 thru 1	1/2 thru 1	1/2 thru 1	1/2 thru 1	1 thru 1-3/4	1/2 thru 1	1/2 thru 1	A	Blue
1-1/4 thru 1-3/4	1-3/4 thru 3	1-1/4 thru 1-3/4	1-1/4 thru 1-3/4	1-1/4 thru 2	1-1/4 thru 2	2 thru 3-1/2	1-1/4 thru 2	1-1/4 thru 2	B	Pink
2 thru 3	3-1/4 thru 5-1/2	2 thru 3	2 thru 3	2-1/4 thru 3	2-1/4 thru 3	4 thru 6	2-1/4 thru 3	2-1/4 thru 3	C	White

*BQC with B15 (15% bleed port) is available.

▼ TYPE Q & BQ

For Refrigerants 22, 134a, 404A, 410A*, 507
SAE Flare & Extended ODF Solder Connections

*Type Q, EQ, and SQ are not approved for R-410A applications.

ELEMENT

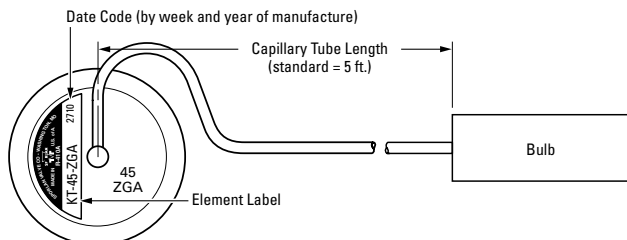

KT	45	Z	GA
Abbreviation for "Kit"	Element Size Number	Refrigerant Code Ⓞ	Thermostatic Charge

SPORLAN REFRIGERANT CODE

ELEMENT	LABEL	COLOR CODE
F	R-12	Yellow
V	R-22, R-422D	Green
J	R-134a	Blue
X	R-401A	Pink
L	R-402A	Sand
S	R-404A	Orange
V	R-407A	Green
N	R-407C	Light Brown
R	R-408A	Purple
F	R-409A	Yellow
Z	R-410A	Pink
R	R-502	Purple
P	R-507	Teal

Ⓞ While many new refrigerants and refrigerant blends have a unique letter code, many use the same thermostatic element as the traditional refrigerant they replace. Refer to the table below to select the correct thermostatic element.

RECOMMENDED THERMOSTATIC ELEMENTS**

APPLICATION	REFRIGERANT													THERMOSTATIC ELEMENT	SYSTEM MOP psig
	12	22, 422D	134a	401A	402A	404A	407A	407C	408A	409A	410A	502	507		
Air Conditioning	X	-	X	X	-	-	-	-	-	X	-	-	-	KT-43-JCP60	50
	-	X	-	-	-	-	X	X	-	-	-	-	-	KT-43-VCP100	90
	-	X	-	-	-	-	X	X	-	-	-	-	-	KT-43-VGA	-
	-	-	-	-	-	X	-	-	X	-	-	X	-	KT-43-SCP115	105
	-	-	-	-	-	-	-	-	-	-	X	-	-	KT-45-ZGA	-
Commercial Refrigeration 50°F to -10°F	X	-	X	X	-	-	-	-	-	X	-	-	-	KT-45-ZCP180	170
	-	X	-	-	-	-	X	X	-	-	-	-	-	KT-43-JC	-
	-	-	-	-	-	X	-	-	X	-	-	X	-	KT-43-VC	-
	-	-	-	-	X	-	-	-	-	-	-	-	X	KT-43-PC	-
	-	-	-	-	-	-	-	-	-	-	-	-	-	KT-43-JZ	-
Low Temperature Refrigeration 0°F to -40°F	X	-	-	-	-	-	-	-	-	-	-	-	-	KT-43-JZP	12
	-	X	-	-	-	-	-	-	-	-	-	-	-	KT-43-VZ	-
	-	X	-	-	-	-	-	-	-	-	-	-	-	KT-43-VZP40	30
	-	-	-	-	X	X	-	-	X	-	-	X	X	KT-43-SZ	-
	-	-	-	-	X	X	-	-	X	-	-	X	X	KT-43-SZP	35

**APPLICATION FACTORS:

- The Sporlan Type ZP thermostatic charges have essentially the same characteristics as the conventional Z cross charges with one exception: they produce a pressure limit or MOP. The ZP charges are not intended as replacements for the Z charges - they should only be used where a definite pressure limit is required to prevent motor overloading.
- All air conditioning and heat pump charges are intended for use with externally equalized valves.
- For dual temperature applications, use the "C" charge.
- The "C" charge may be used on applications down to -30°F on R-22, R-404A and R-507.
- R-410A elements for use with BQ, EBQ, and SBQ only.

ORDERING INSTRUCTIONS VALVE NOMENCLATURE

	BODY	CARTRIDGE	ELEMENT				
QE	3/8 x 1/2 x 1/4 SAE	QC	2	KT-43	V	C	5'
Valve Type Q, EQ, SQ Internally Equalized QE, EQE, SQE Externally Equalized	Connection Size and Style: Inlet x Outlet x External Equalizer	Cartridge Type	Cartridge Size	Element Kit KT-43	Refrigerant Code (See above)	Thermostatic Charge	Capillary Tube Length
BQE	3/8 x 1/2 x 1/4 SAE	BQC	AA	KT-43	V	C	5'
Valve Type BQ, EBQ, SBQ Internally Equalized BQE, EBQE, SBQE Externally Equalized	Connection Size and Style: Inlet x Outlet x External Equalizer	Cartridge Type	Cartridge Size	Element Kit KT-43 or KT-45 (R-410A only)	Refrigerant Code (See above)	Thermostatic Charge	Capillary Tube Length

▼ TYPE Q & BQ

For Refrigerants 22, 134a, 404A, 410A*, 507
SAE Flare & Extended ODF Solder Connections

*Type Q, EQ, and SQ are not approved for R-410A applications.

Q SPECIFICATIONS ELEMENT SIZE NO. 43, KNIFE EDGE JOINT

REFRIGERANT (Sporlan Code)	BODY TYPE - CARTRIDGE						CARTRIDGE	NOMINAL CAPACITY Tons of Refrigeration	THERMOSTATIC CHARGES AVAILABLE	STANDARD TUBING LENGTH	CONNECTIONS Inches Blue figures are standard and will be furnished unless otherwise specified.	NET WEIGHT	SHIPPING WEIGHT
	SAE Flare		Extended ODF Solder										
	Internal Equalizer ①	External Equalizer ②	Internal Equalizer ①	External Equalizer ②	Internal Equalizer ①	External Equalizer ②							
22 (V) 407C (N) 407A (V) 422D (V)	Q-0	QE-0	EQ-0	EQE-0	SQ-0	SQE-0	0	1/3	Refer to Recommended Thermostatic Elements on Page 19	5 ft. 1.5 m	Q & QE Only 1/4 x 3/8 SAE 90° Angle Inlet or 1/4 x 1/2 SAE 90° Angle Inlet or 3/8 x 1/2 SAE 90° Angle Inlet EQ Only 3/8 x 1/2 ODF Straight Thru EQE Only 3/8 x 1/2 ODF Straight Thru or 3/8 x 5/8 ODF Straight Thru or 1/2 x 5/8 ODF Straight Thru or 1/2 x 7/8 ODF Straight Thru SQ & SQE Only 3/8 x 1/2 ODF 90° Angle Inlet	1 lb. 454 g	1-1/2 lbs. 680 g
	Q-1	QE-1	EQ-1	EQE-1	SQ-1	SQE-1	1	3/4					
	Q-2	QE-2	EQ-2	EQE-2	SQ-2	SQE-2	2	1					
	Q-3	QE-3	EQ-3	EQE-3	SQ-3	SQE-3	3	1-1/2					
	Q-4	QE-4	EQ-4	EQE-4	SQ-4	SQE-4	4	2-1/2					
	Q-5	QE-5	EQ-5	EQE-5	SQ-5	SQE-5	5	3-1/2					
	Q-6	QE-6	EQ-6	EQE-6	SQ-6	SQE-6	6	5					
134a (J) 12 (F) 401A (X) 409A (F)	Q-0	QE-0	EQ-0	EQE-0	SQ-0	SQE-0	0	1/6					
	Q-1	QE-1	EQ-1	EQE-1	SQ-1	SQE-1	1	1/4					
	Q-2	QE-2	EQ-2	EQE-2	SQ-2	SQE-2	2	1/2					
	Q-3	QE-3	EQ-3	EQE-3	SQ-3	SQE-3	3	1					
	Q-4	QE-4	EQ-4	EQE-4	SQ-4	SQE-4	4	1-1/2					
	Q-5	QE-5	EQ-5	EQE-5	SQ-5	SQE-5	5	2					
	Q-6	QE-6	EQ-6	EQE-6	SQ-6	SQE-6	6	2-1/2					
404A (S) 502 (R) 408A (R)	Q-0	QE-0	EQ-0	EQE-0	SQ-0	SQE-0	0	1/6					
	Q-1	QE-1	EQ-1	EQE-1	SQ-1	SQE-1	1	1/4					
	Q-2	QE-2	EQ-2	EQE-2	SQ-2	SQE-2	2	1/2					
	Q-3	QE-3	EQ-3	EQE-3	SQ-3	SQE-3	3	1					
	Q-4	QE-4	EQ-4	EQE-4	SQ-4	SQE-4	4	1-1/2					
	Q-5	QE-5	EQ-5	EQE-5	SQ-5	SQE-5	5	2					
	Q-6	QE-6	EQ-6	EQE-6	SQ-6	SQE-6	6	3					
507 (P) 402A (L)	Q-0	QE-0	EQ-0	EQE-0	SQ-0	SQE-0	0	1/6					
	Q-1	QE-1	EQ-1	EQE-1	SQ-1	SQE-1	1	1/4					
	Q-2	QE-2	EQ-2	EQE-2	SQ-2	SQE-2	2	1/2					
	Q-3	QE-3	EQ-3	EQE-3	SQ-3	SQE-3	3	1					
	Q-4	QE-4	EQ-4	EQE-4	SQ-4	SQE-4	4	1-1/2					
	Q-5	QE-5	EQ-5	EQE-5	SQ-5	SQE-5	5	2					
	Q-6	QE-6	EQ-6	EQE-6	SQ-6	SQE-6	6	3					

BQ SPECIFICATIONS ELEMENT SIZE NO. 43 (R-22) and NO. 45 (R-410A), KNIFE EDGE JOINT

REFRIGERANT (Sporlan Code)	BODY TYPE - CARTRIDGE						CARTRIDGE	NOMINAL CAPACITY Tons of Refrigeration	THERMOSTATIC CHARGES AVAILABLE	STANDARD TUBING LENGTH	CONNECTIONS Inches Blue figures are standard and will be furnished unless otherwise specified.	NET WEIGHT	SHIPPING WEIGHT
	SAE Flare		Extended ODF Solder										
	Internal Equalizer ①	External Equalizer ②	Internal Equalizer ①	External Equalizer ②	Internal Equalizer ①	External Equalizer ②							
22 (V) 407C (N) 407A (V) 422D (V)	BQ-AAA	BQE-AAA	EBQ-AAA	EBQE-AAA	SBQ-AAA	SBQE-AAA	AAA	1/8 thru 1/3	Refer to Recommended Thermostatic Elements on Page 19	5 ft. 1.5 m	BQ & BQE 1/4 x 3/8 SAE 90° Angle Inlet or 1/4 x 1/2 SAE 90° Angle Inlet or 3/8 x 1/2 SAE ☉ 90° Angle Inlet EBQ Only 3/8 x 1/2 ODF ☉ Straight Thru EBQE Only 3/8 x 1/2 ODF ☉ Straight Thru or 3/8 x 1/2 ODF ☉ 90° Angle Inlet or 1/2 x 5/8 ODF ☉ Straight Thru or 1/2 x 7/8 ODF ☉ Straight Thru SBQ & SBQE Only 3/8 x 1/2 ODF ☉ 90° Angle Inlet	1 lb. 454 g	1-1/2 lbs. 680 g
	BQ-AA	BQE-AA	EBQ-AA	EBQE-AA	SBQ-AA	SBQE-AA	AA	1/2 thru 2/3					
	BQ-A	BQE-A	EBQ-A	EBQE-A	SBQ-A	SBQE-A	A	3/4 thru 1-1/2					
	BQ-B	BQE-B	EBQ-B	EBQE-B	SBQ-B	SBQE-B	B	1-3/4 thru 3					
	BQ-C	BQE-C	EBQ-C	EBQE-C	SBQ-C	SBQE-C	C	3-1/4 thru 5-1/2					
134a (J) 12 (F) 401A (X) 409A (F)	BQ-AAA	BQE-AAA	EBQ-AAA	EBQE-AAA	SBQ-AAA	SBQE-AAA	AAA	1/8 thru 1/5					
	BQ-AA	BQE-AA	EBQ-AA	EBQE-AA	SBQ-AA	SBQE-AA	AA	1/4 thru 1/3					
	BQ-A	BQE-A	EBQ-A	EBQE-A	SBQ-A	SBQE-A	A	1/2 thru 1					
	BQ-B	BQE-B	EBQ-B	EBQE-B	SBQ-B	SBQE-B	B	1-1/4 thru 1-3/4					
404A (S) 502 (R) 408A (R)	BQ-AAA	BQE-AAA	EBQ-AAA	EBQE-AAA	SBQ-AAA	SBQE-AAA	AAA	1/8 thru 1/5					
	BQ-AA	BQE-AA	EBQ-AA	EBQE-AA	SBQ-AA	SBQE-AA	AA	1/4 thru 1/3					
	BQ-A	BQE-A	EBQ-A	EBQE-A	SBQ-A	SBQE-A	A	1/2 thru 1					
	BQ-B	BQE-B	EBQ-B	EBQE-B	SBQ-B	SBQE-B	B	1-1/4 thru 2					
410A (Z)	BQ-AAA	BQE-AAA	EBQ-AAA	EBQE-AAA	SBQ-AAA	SBQE-AAA	AAA	1/8 thru 1/5					
	BQ-AA	BQE-AA	EBQ-AA	EBQE-AA	SBQ-AA	SBQE-AA	AA	1/2 thru 3/4					
	BQ-A	BQE-A	EBQ-A	EBQE-A	SBQ-A	SBQE-A	A	1 thru 1-3/4					
	BQ-B	BQE-B	EBQ-B	EBQE-B	SBQ-B	SBQE-B	B	2 thru 3-1/2					
507 (P) 402A (L)	BQ-AAA	BQE-AAA	EBQ-AAA	EBQE-AAA	SBQ-AAA	SBQE-AAA	AAA	1/8 thru 1/5					
	BQ-AA	BQE-AA	EBQ-AA	EBQE-AA	SBQ-AA	SBQE-AA	AA	1/4 thru 1/3					
	BQ-A	BQE-A	EBQ-A	EBQE-A	SBQ-A	SBQE-A	A	1/2 thru 1					
	BQ-B	BQE-B	EBQ-B	EBQE-B	SBQ-B	SBQE-B	B	1-1/4 thru 2					

① Valves listed in the column are NOT AVAILABLE with MOP type air conditioning charges.
 ② Standard External Equalizer 1/4" SAE (Q and BQ Body), 1/4" ODF (SQ, SBQ, EQ and EBQ Body).
 ③ The 3/8" SAE inlet fitting has a long taper on the flare surface. A 3/8" x 1/4" reducing flare nut will allow 1/4" OD tubing to be attached to this fitting.
 ④ ODF Solder indicates a female connection on the valve of proper diameter to receive copper tubing of corresponding OD size. Thus 1/2" ODF will receive 1/2" OD tubing.

▼ TYPE Q & BQ

For Refrigerants 22, 134a, 404A, 410A*, 507
SAE Flare & Extended ODF Solder Connections

*Type Q, EQ, and SQ are not approved for R-410A applications.

TYPE QE	TYPE BQE																				
<p>1/4 SAE Inlet Strainer P/N 3008-000 3/8 SAE Inlet Strainer P/N 1538-000</p>	<p>1/4 SAE Inlet Strainer P/N 3008-000 3/8 SAE Inlet Strainer P/N 1538-000</p>																				
<p>QE & BQE DIMENSIONS CONNECTIONS - Inches</p> <table border="1" style="margin: auto;"> <thead> <tr> <th>FITTING SIZE</th> <th>A</th> <th>B</th> <th>C</th> </tr> </thead> <tbody> <tr> <td>1/4 SAE, 90° Angle</td> <td>1.19</td> <td>—</td> <td>1.44</td> </tr> <tr> <td>3/8 SAE, 90° Angle</td> <td>1.35</td> <td>—</td> <td>1.08</td> </tr> <tr> <td>3/8 SAE</td> <td>—</td> <td>1.61</td> <td>—</td> </tr> <tr> <td>1/2 SAE</td> <td>—</td> <td>1.80</td> <td>—</td> </tr> </tbody> </table> <p>Top View 60° 1.54</p>		FITTING SIZE	A	B	C	1/4 SAE, 90° Angle	1.19	—	1.44	3/8 SAE, 90° Angle	1.35	—	1.08	3/8 SAE	—	1.61	—	1/2 SAE	—	1.80	—
FITTING SIZE	A	B	C																		
1/4 SAE, 90° Angle	1.19	—	1.44																		
3/8 SAE, 90° Angle	1.35	—	1.08																		
3/8 SAE	—	1.61	—																		
1/2 SAE	—	1.80	—																		

TYPE EQE	TYPE EBQE																				
<p>3/8 ODF Insert Strainer P/N 877-003 1/2 ODF Insert Strainer P/N 877-004</p>	<p>3/8 ODF Insert Strainer P/N 877-003 1/2 ODF Insert Strainer P/N 877-004</p>																				
<p>EQE & EBQE DIMENSIONS CONNECTIONS - Inches</p> <table border="1" style="margin: auto;"> <thead> <tr> <th>FITTING SIZE</th> <th>A</th> <th>B</th> <th>C</th> </tr> </thead> <tbody> <tr> <td>3/8</td> <td>2.50</td> <td>—</td> <td>0.31</td> </tr> <tr> <td>1/2</td> <td>2.42</td> <td>2.48</td> <td>0.40</td> </tr> <tr> <td>5/8</td> <td>—</td> <td>2.48</td> <td>0.50</td> </tr> <tr> <td>7/8</td> <td>—</td> <td>2.39</td> <td>0.78</td> </tr> </tbody> </table> <p>Top View 60° 1.87</p>		FITTING SIZE	A	B	C	3/8	2.50	—	0.31	1/2	2.42	2.48	0.40	5/8	—	2.48	0.50	7/8	—	2.39	0.78
FITTING SIZE	A	B	C																		
3/8	2.50	—	0.31																		
1/2	2.42	2.48	0.40																		
5/8	—	2.48	0.50																		
7/8	—	2.39	0.78																		

TYPE SQE	TYPE SBQE
<p>Removable Strainer P/N 3427-000</p>	<p>Removable Strainer P/N 3427-000</p>
<p>Top View 60° 1.87</p>	

BULB SIZES - Inches

STANDARD CHARGES	REFRIGERANT				
	22	134a	404A	410A	507
C	0.50 OD x 3.00				
Z & ZP Series	0.50 OD x 3.00	—	0.50 OD x 3.00	—	0.50 OD x 3.00
CP Series	0.50 OD x 3.00				
GA	0.75 OD x 2.00	—	—	0.75 OD x 2.00	—

▼ TYPE G

For Refrigerants 22, 134a, 404A, 507
SAE Flare Connections

Sporlan Type G valve is a forged brass body, externally adjustable valve with SAE flare connections. The thermostatic element is replaceable, and the inlet connection has a removable 100 mesh strainer. This valve is designed for small refrigeration systems such as refrigerated cases, coolers and freezers. In addition to refrigeration applications, the externally equalized Type G valve may be used for small capacity air conditioning and heat pump units.

Outlet Connections
1/2" SAE

Mating Distributors (See Bulletin 20-10)
1603, 1605, 1606, 1608, 1650(R)

For complete details of construction, see page 35.



Type G

SPECIFICATIONS ELEMENT SIZE NO. 53, KNIFE EDGE JOINT

REFRIGERANT (Sporlan Code)	VALVE TYPE		NOMINAL CAPACITY Tons of Refrigeration	THERMOSTATIC CHARGES AVAILABLE	STANDARD TUBING LENGTH	CONNECTIONS - Inches SAE Flare		NET WEIGHT	SHIPPING WEIGHT
	Internal Equalizer ①	External Equalizer 1/4" SAE Flare				Blue figures are standard and will be furnished unless otherwise specified.			
						INLET	OUTLET		
22 (V) 407C (N) 407A (V) 422D (V)	GV-1/5	GVE-1/5	1/5	Refer to Recommended Thermostatic Charges on page 3	5 ft. 1.5 m	1/4 or 3/8 ②	1/2	2 lbs. 0.90 kg	3 lbs. 1.36 kg
	GV-1/3	GVE-1/3	1/3						
	GV-1/2	GVE-1/2	1/2						
	GV-3/4	GVE-3/4	3/4						
	GV-1	GVE-1	1						
	GV-1-1/2	GVE-1-1/2	1-1/2						
	—	GVE-2	2						
	GV-2-1/2	—	2-1/2						
—	GVE-3	3							
134a (J) 12 (F) 401A (X) 409A (F)	GJ-1/8	GJE-1/8	1/8						
	GJ-1/6	GJE-1/6	1/6						
	GJ-1/4	GJE-1/4	1/4						
	GJ-1/2	GJE-1/2	1/2						
	GJ-1	GJE-1	1						
	GJ-1-1/2	GJE-1-1/2	1-1/2						
—	GJE-2	2							
404A (S) 502 (R) 408A (R)	GS-1/8	GSE-1/8	1/8						
	GS-1/6	GSE-1/6	1/6						
	GS-1/4	GSE-1/4	1/4						
	GS-1/2	GSE-1/2	1/2						
	GS-1	GSE-1	1						
	GS-1-1/2	GSE-1-1/2	1-1/2						
—	GSE-2	2							
507 (P) 402A (L)	GP-1/8	GPE-1/8	1/8						
	GP-1/6	GPE-1/6	1/6						
	GP-1/4	GPE-1/4	1/4						
	GP-1/2	GPE-1/2	1/2						
	GP-1	GPE-1	1						
	GP-1-1/2	GPE-1-1/2	1-1/2						
—	GPE-2	2							

① Valves listed in this column NOT AVAILABLE with MOP Type air conditioning charges.
② The 3/8" SAE inlet fitting has a long taper on the flare surface. A 3/8" x 1/4" reducing flare nut will allow 1/4" OD tubing to be attached to this fitting.

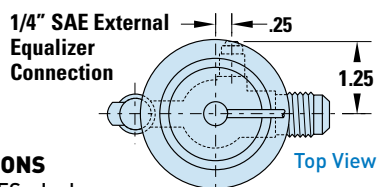

DIMENSIONS

BULB SIZES - Inches

STANDARD CHARGES	REFRIGERANT			
	22	134a	404A	507
C	0.50 OD x 3.50			
Z & ZP Series	0.50 OD x 3.50	—	0.50 OD x 3.50	—
X	0.75 OD x 4.00	—	0.75 OD x 4.00	—
CP Series	0.50 OD x 3.50			
VGA	0.75 OD x 2.00	—	—	—

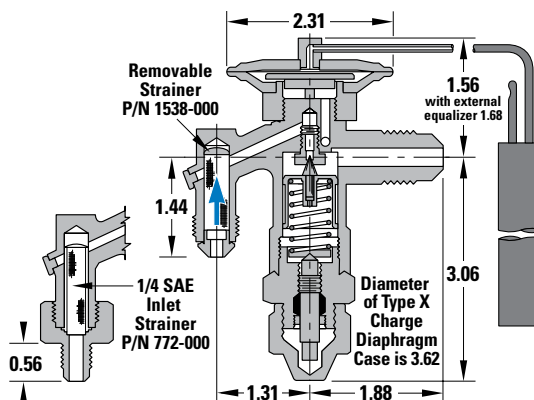

▼ TYPE EG

For Refrigerants 22, 134a, 404A, 507
ODF Solder Connections

Sporlan Type EG valve is a forged brass body, externally adjustable valve with ODF solder connections. The thermostatic element is replaceable, and the inlet connection has a removable 100 mesh strainer which can be cleaned and/or replaced without removing the valve from the line. This valve is designed for small refrigeration systems such as refrigerated cases, coolers and freezers. In addition to refrigeration applications, the externally equalized Type EG valve

may be used for small capacity air conditioning and heat pump units.

Outlet Connections

1/2" ODF

Mating Distributors (See Bulletin 20-10)

D260, D262

For complete details of construction, see page 35.



Type EG

SPECIFICATIONS ELEMENT SIZE NO. 53, KNIFE EDGE JOINT

REFRIGERANT (Sporlan Code)	VALVE TYPE		NOMINAL CAPACITY Tons of Refrigeration	THERMOSTATIC CHARGES AVAILABLE	STANDARD TUBING LENGTH	CONNECTIONS - Inches ② ODF Solder Blue figures are standard and will be furnished unless otherwise specified.		NET WEIGHT	SHIPPING WEIGHT
	Internal Equalizer ①	External Equalizer 1/4" ODF Solder				INLET	OUTLET		
22 (V) 407C (N) 407A (V) 422D (V)	EGV-1/5	EGVE-1/5	1/5	Refer to Recommended Thermostatic Charges on page 3	5 ft. 1.5 m	3/8	1/2	2 lbs. 0.90 kg	3 lbs. 1.36 kg
	EGV-1/3	EGVE-1/3	1/3						
	EGV-1/2	EGVE-1/2	1/2						
	EGV-3/4	EGVE-3/4	3/4						
	EGV-1	EGVE-1	1						
	EGV-1-1/2	EGVE-1-1/2	1-1/2						
	-	EGVE-2	2						
	EGV-2-1/2	-	2-1/2						
-	EGVE-3	3							
134a (J) 12 (F) 401A (X) 409A (F)	EGJ-1/8	EGJE-1/8	1/8						
	EGJ-1/6	EGJE-1/6	1/6						
	EGJ-1/4	EGJE-1/4	1/4						
	EGJ-1/2	EGJE-1/2	1/2						
	EGJ-1	EGJE-1	1						
	EGJ-1-1/2	EGJE-1-1/2	1-1/2						
404A (S) 502 (R) 408A (R)	EGS-1/8	EGSE-1/8	1/8						
	EGS-1/6	EGSE-1/6	1/6						
	EGS-1/4	EGSE-1/4	1/4						
	EGS-1/2	EGSE-1/2	1/2						
	EGS-1	EGSE-1	1						
	EGS-1-1/2	EGSE-1-1/2	1-1/2						
507 (P) 402A (L)	EGP-1/8	EGPE-1/8	1/8						
	EGP-1/6	EGPE-1/6	1/6						
	EGP-1/4	EGPE-1/4	1/4						
	EGP-1/2	EGPE-1/2	1/2						
	EGP-1	EGPE-1	1						
	EGP-1-1/2	EGPE-1-1/2	1-1/2						
-	EGPE-2	2							

① Valves listed in this column NOT AVAILABLE with MOP Type air conditioning charges.

② ODF Solder indicates a female connection on the valve of proper diameter to receive copper tubing of corresponding OD size. Thus 1/2" ODF will receive 1/2" OD tubing.

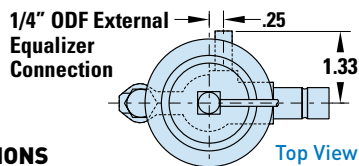

DIMENSIONS

BULB SIZES - Inches

STANDARD CHARGES	REFRIGERANT			
	22	134a	404A	507
C	0.50 OD x 3.50			
Z & ZP Series	0.50 OD x 3.50	-	0.50 OD x 3.50	-
X	0.75 OD x 4.00	-	0.75 OD x 4.00	-
CP Series	0.50 OD x 3.50		-	-
VGA	0.75 OD x 2.00	-	-	-

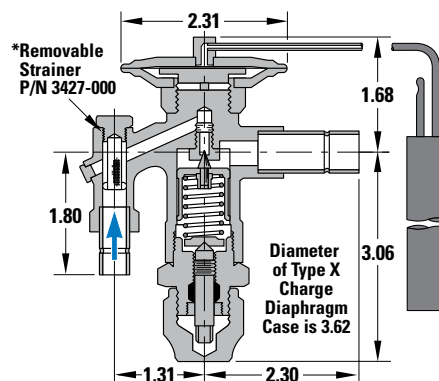

* Type EG valves manufactured prior to June 1994 use a smaller inlet strainer, P/N 1935-000, which has a 1/2" brass hex head. Current Type EG valves use inlet strainer P/N 3427-000 which has a 5/8" brass hex head. These strainers are not interchangeable. The 3427-000 is available as a replacement part. The 1935-000 is no longer available.

▼ TYPE BF

For Refrigerants 22, 134a, 404A, 507
SAE Flare Connections

Sporlan Type BF valve is a small brass bar body valve with SAE flare connections and balanced port construction. This valve has the same exterior dimensions as the Type F valve. The thermostatic element is replaceable, and the inlet connection has a removable 100 mesh strainer. The balanced port construction makes this valve ideally suited for small capacity refrigeration applications which operate over widely varying operating conditions.

Outlet Connections
1/2" SAE

Mating Distributors (See Bulletin 20-10)
1603, 1605, 1606, 1608, 1650(R)

For complete details of construction, see page 35.

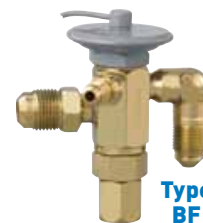

Type BF

SPECIFICATIONS ELEMENT SIZE NO. 43, KNIFE EDGE JOINT

REFRIGERANT (Sporlan Code)	VALVE TYPE		PORT SIZE	NOMINAL CAPACITY Tons of Refrigeration	THERMOSTATIC CHARGES AVAILABLE	STANDARD TUBING LENGTH	CONNECTIONS - Inches SAE Flare <i>Blue figures are standard and will be furnished unless otherwise specified.</i>			NET WEIGHT	SHIPPING WEIGHT
	SAE Flare						INLET	OUTLET	EXTERNAL EQUALIZER		
	Internal Equalizer	External Equalizer									
22 (V) 407C (N) 407A (V) 422D (V)	BFV-AAA	BFVE-AAA	AAA	1/8 thru 1/3	C Z ZP40	30 in. 760 mm	1/4 or 3/8 Elbow ①	3/8 or 1/2	1/4	1 lb. 454 g	1-1/2 lbs. 680 g
	BFV-AA	BFVE-AA	AA	1/2 thru 2/3			1/4 or 3/8 Elbow ①				
	BFV-A	BFVE-A	A	3/4 thru 1-1/2			3/8 Elbow				
	BFV-B	BFVE-B	B	1-3/4 thru 3							
134a (J) 12 (F) 401A (X) 409A (F)	BFJ-AAA	BFJE-AAA	AAA	1/8 thru 1/5	C	30 in. 760 mm	1/4 or 3/8 Elbow ①	3/8 or 1/2	1/4	1 lb. 454 g	1-1/2 lbs. 680 g
	BFJ-AA	BFJE-AA	AA	1/4 thru 1/3			1/4 or 3/8 Elbow ①				
	BFJ-A	BFJE-A	A	1/2 thru 1			3/8 Elbow				
	BFJ-B	BFJE-B	B	1-1/4 thru 1-3/4							
404A (S) 502 (R) 408A (R)	BFS-AAA	BFSE-AAA	AAA	1/8 thru 1/5	C Z ZP	30 in. 760 mm	1/4 or 3/8 Elbow ①	3/8 or 1/2	1/4	1 lb. 454 g	1-1/2 lbs. 680 g
	BFS-AA	BFSE-AA	AA	1/4 thru 1/3			1/4 or 3/8 Elbow ①				
	BFS-A	BFSE-A	A	1/2 thru 1			3/8 Elbow				
	BFS-B	BFSE-B	B	1-1/4 thru 2							
507 (P) 402A (L)	BFP-AAA	BFPE-AAA	AAA	1/8 thru 1/5	C Z ZP	30 in. 760 mm	1/4 or 3/8 Elbow ①	3/8 or 1/2	1/4	1 lb. 454 g	1-1/2 lbs. 680 g
	BFP-AA	BFPE-AA	AA	1/4 thru 1/3			1/4 or 3/8 Elbow ①				
	BFP-A	BFPE-A	A	1/2 thru 1			3/8 Elbow				
	BFP-B	BFPE-B	B	1-1/4 thru 2							
BFP-C	BFPE-C	C	2-1/4 thru 3								

① The 3/8" SAE inlet fitting has a long taper on the flare surface. A 3/8" x 1/4" reducing flare nut will allow 1/4" OD tubing to be attached to this fitting.

DIMENSIONS

CONNECTIONS - Inches

FITTING SIZE SAE Flare	A	B	C
1/4 Elbow	1.19	—	1.34
3/8 Elbow	1.35	—	0.98
3/8 SAE	—	1.61	—
1/2 SAE	—	1.80	—

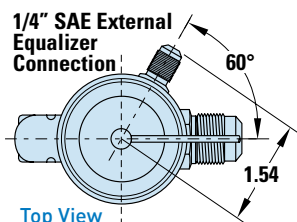

BULB SIZES - Inches

STANDARD CHARGES	REFRIGERANT			
	22	134a	404A	507
C	0.50 OD x 3.00			
Z & ZP Series	0.50 OD x 3.00	—	0.50 OD x 3.00	

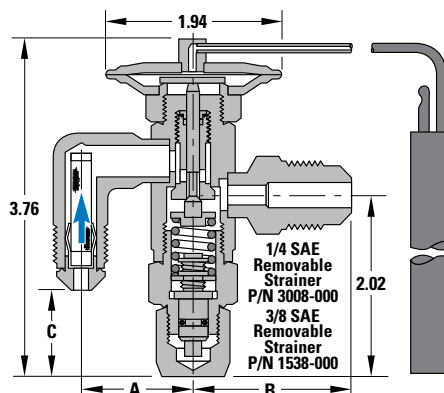

▼ TYPE SBF & EBF

For Refrigerants 22, 134a, 404A, 507
Extended Solder Connections

Sporlan Types SBF & EBF are small brass bar body valves with Extended ODF solder connections and the same balanced port construction as the Type BF valve. Both valves have replaceable thermostatic elements. The Type EBF has a 100 mesh insert strainer. The Type SBF has a 100 mesh removable strainer that can be cleaned and/or replaced while the valve is still soldered to the system tubing. The balanced port construction makes these valves ideally suited for small

capacity refrigeration applications which operate over widely varying conditions.

Outlet Connections
1/2" ODF, 5/8" ODF

Mating Distributors (See Bulletin 20-10)
D260, D262, 1620, 1622, 1651(R)

For complete details of construction, see page 35.

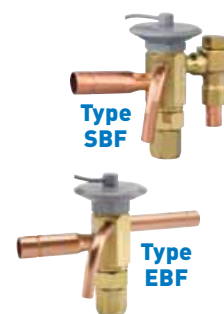

SPECIFICATIONS ELEMENT SIZE NO. 43, KNIFE EDGE JOINT

REFRIGERANT (Sporlan Code)	TYPE SBF		TYPE EBF		PORT SIZE	NOMINAL CAPACITY RANGE Tons of Refrigeration	THERMOSTATIC CHARGES AVAILABLE	STANDARD TUBING LENGTH	CONNECTIONS - Inches			NET WEIGHT	SHIPPING WEIGHT
	Extended ODF Solder with replaceable strainer		Extended ODF Solder						① Extended ODF Solder Blue figures are standard and will be furnished unless otherwise specified.				
	Internal Equalizer	External Equalizer	Internal Equalizer	External Equalizer					INLET	OUTLET	EXTERNAL EQUALIZER		
22 (V) 407C (N) 407A (V) 422D (V)	SBFV-AAA	SBFVE-AAA	EBFV-AAA	EBFVE-AAA	AAA	1/8 thru 1/3	C Z ZP40	30 in. 760 mm	3/8	1/2 or 5/8	1/4 Pointed Toward Bottom Cap or Parallel to Outlet Connection	1 lb. 454 g	1-1/2 lbs. 680 g
	SBFV-AA	SBFVE-AA	EBFV-AA	EBFVE-AA	AA	1/2 thru 2/3							
	SBFV-A	SBFVE-A	EBFV-A	EBFVE-A	A	3/4 thru 1-1/2							
	SBFV-B	SBFVE-B	EBFV-B	EBFVE-B	B	1-3/4 thru 3							
	SBFV-C	SBFVE-C	EBFV-C	EBFVE-C	C	3-1/4 thru 5-1/2							
134a (J) 12 (F) 401A (X) 409A (F)	SBFJ-AAA	SBFJE-AAA	EBFJ-AAA	EBFJE-AAA	AAA	1/8 thru 1/5	C	30 in. 760 mm	3/8	1/2 or 5/8	1/4 Pointed Toward Bottom Cap or Parallel to Outlet Connection	1 lb. 454 g	1-1/2 lbs. 680 g
	SBFJ-AA	SBFJE-AA	EBFJ-AA	EBFJE-AA	AA	1/4 thru 1/3							
	SBFJ-A	SBFJE-A	EBFJ-A	EBFJE-A	A	1/2 thru 1							
	SBFJ-B	SBFJE-B	EBFJ-B	EBFJE-B	B	1-1/4 thru 1-3/4							
	SBFJ-C	SBFJE-C	EBFJ-C	EBFJE-C	C	2 thru 3							
404A (S) 502 (R) 408A (R)	SBFS-AAA	SBFSE-AAA	EBFS-AAA	EBFSE-AAA	AAA	1/8 thru 1/5	C Z ZP	30 in. 760 mm	3/8	1/2 or 5/8	1/4 Pointed Toward Bottom Cap or Parallel to Outlet Connection	1 lb. 454 g	1-1/2 lbs. 680 g
	SBFS-AA	SBFSE-AA	EBFS-AA	EBFSE-AA	AA	1/4 thru 1/3							
	SBFS-A	SBFSE-A	EBFS-A	EBFSE-A	A	1/2 thru 1							
	SBFS-B	SBFSE-B	EBFS-B	EBFSE-B	B	1-1/4 thru 2							
	SBFS-C	SBFSE-C	EBFS-C	EBFSE-C	C	2-1/4 thru 3							
507 (P) 402A (L)	SBFP-AAA	SBFPE-AAA	EBFP-AAA	EBFPE-AAA	AAA	1/8 thru 1/5	C Z ZP	30 in. 760 mm	3/8	1/2 or 5/8	1/4 Pointed Toward Bottom Cap or Parallel to Outlet Connection	1 lb. 454 g	1-1/2 lbs. 680 g
	SBFP-AA	SBFPE-AA	EBFP-AA	EBFPE-AA	AA	1/4 thru 1/3							
	SBFP-A	SBFPE-A	EBFP-A	EBFPE-A	A	1/2 thru 1							
	SBFP-B	SBFPE-B	EBFP-B	EBFPE-B	B	1-1/4 thru 2							
	SBFP-C	SBFPE-C	EBFP-C	EBFPE-C	C	2-1/4 thru 3							

① ODF Solder indicates a female connection on the valve of proper diameter to receive copper tubing of corresponding OD size. Thus 1/2" ODF will receive 1/2" OD tubing.

▼ TYPE SBF & EBF

For Refrigerants 22, 134a, 404A, 507
Extended Solder Connections

TYPE SBF

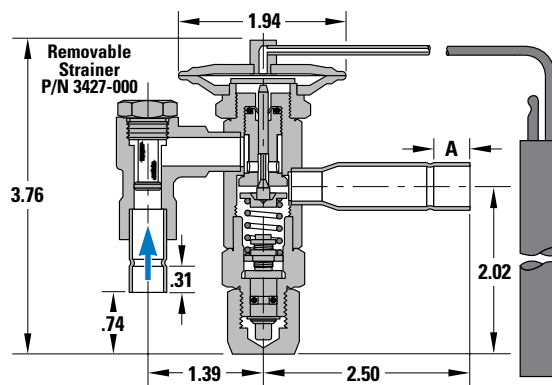
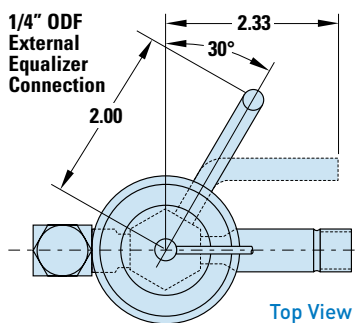

DIMENSIONS

CONNECTIONS - Inches

OUTLET FITTING SIZE	A
1/2	0.40
5/8	0.50

BULB SIZES - Inches

STANDARD CHARGES	REFRIGERANT			
	22	134a	404A	507
C	0.50 OD x 3.00			
Z & ZP Series	0.50 OD x 3.00	-	0.50 OD x 3.00	

TYPE EBF

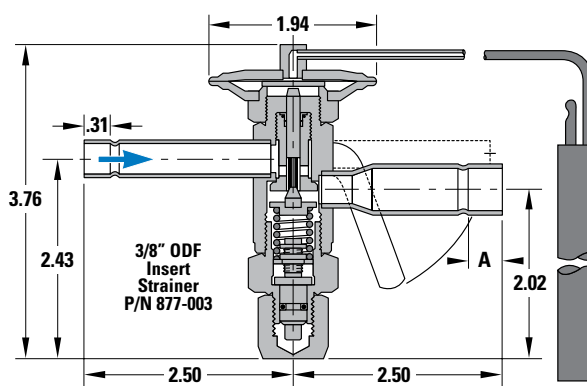
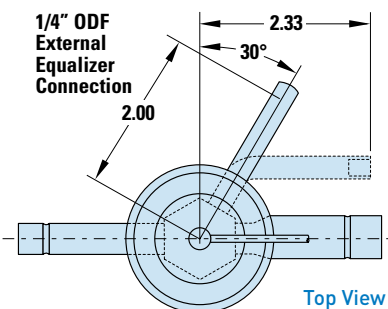

DIMENSIONS

CONNECTIONS - Inches

OUTLET FITTING SIZE	A
1/2	0.40
5/8	0.50

BULB SIZES - Inches

STANDARD CHARGES	REFRIGERANT			
	22	134a	404A	507
C	0.50 OD x 3.00			
Z & ZP Series	0.50 OD x 3.00	-	0.50 OD x 3.00	

▼ TYPE S

For Refrigerants 22, 134a, 404A, 507
ODF Solder Connections

Sporlan Type S valve is a brass bar body, externally adjustable valve with ODF solder connections. The thermostatic element is replaceable, and the inlet connection has a permanent 12 mesh strainer. This valve is designed for both air conditioning and refrigeration applications.

Outlet Connections
5/8" ODF, 7/8" ODF, 1-1/8" ODF

Mating Distributors (See Bulletin 20-10)
1112, 1113, 1115, 1116, 1620, 1622, 1651(R), 1653(R), 1655(R)

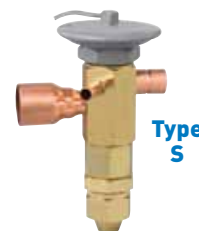

For complete details of construction, see page 35.

SPECIFICATIONS ELEMENT SIZE NO. 83, KNIFE EDGE JOINT

REFRIGERANT (Sporlan Code)	VALVE TYPE		NOMINAL CAPACITY Tons of Refrigeration	THERMOSTATIC CHARGES AVAILABLE	STANDARD TUBING LENGTH	CONNECTIONS - Inches ② ODF Solder Blue figures are standard and will be furnished unless otherwise specified.		NET WEIGHT	SHIPPING WEIGHT
	Internal Equalizer ①	External Equalizer				INLET	OUTLET		
134a (J) 12 (F) 401A (X) 409A (F)	SJ-2	SJE-2	2	3/8 or 1/2	5/8, 7/8 or 1-1/8				
	SJ-2-1/2	SJE-2-1/2	2-1/2	1/2	5/8, 7/8 or 1-1/8				
	SJ-3	SJE-3	3	5/8	7/8 or 1-1/8				
	—	SJE-5	5	3/8 or 1/2	5/8, 7/8 or 1-1/8				
404A (S) 502 (R) 408A (R)	—	SJE-6	6	1/2	5/8, 7/8 or 1-1/8				
	SS-2	SSE-2	2	5/8	7/8 or 1-1/8				
	SS-3	SSE-3	3	3/8 or 1/2	5/8, 7/8 or 1-1/8				
	SS-4	SSE-4	4	1/2	5/8, 7/8 or 1-1/8				
507 (P) 402A (L)	—	SSE-6	6	5/8	7/8 or 1-1/8				
	—	SSE-7	7	3/8 or 1/2	5/8, 7/8 or 1-1/8				
	SP-2	SPE-2	2	1/2	5/8, 7/8 or 1-1/8				
	SP-3	SPE-3	3	5/8	7/8 or 1-1/8				
	SP-4	SPE-4	4	1/2	5/8, 7/8 or 1-1/8				
—	SPE-6	6	5/8	7/8 or 1-1/8					
—	SPE-7	7							

① Valves listed in this column NOT AVAILABLE with MOP Type air conditioning charges.

② ODF Solder indicates a female connection on the valve of proper diameter to receive copper tubing of corresponding OD size. Thus 5/8" ODF will receive 5/8" OD tubing.

DIMENSIONS

CONNECTIONS - Inches

FITTING SIZE	A	B	C
3/8	1.34	—	0.31
1/2	1.29	1.36	0.40
5/8	1.50	1.57	0.50
7/8	—	2.13	0.78
1-1/8	—	2.19	0.91

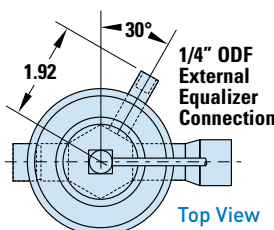

BULB SIZES - Inches

STANDARD CHARGES	REFRIGERANT			
	22	134a	404A	507
C	0.50 OD x 3.50			
Z & ZP Series	0.50 OD x 3.50	—	0.50 OD x 3.50	—
X	0.75 OD x 4.00	—	0.75 OD x 4.00	—
CP Series	0.50 OD x 3.50			
VGA	0.75 OD x 2.00	—	—	—

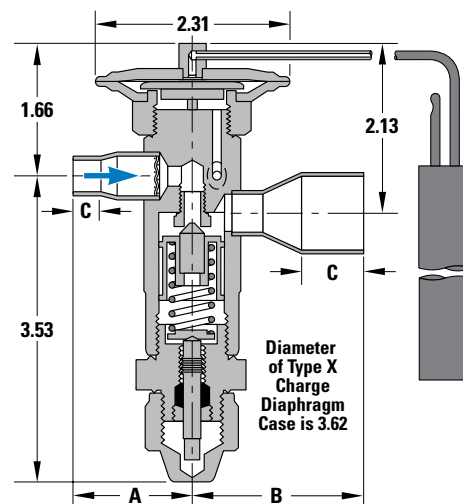

▼ TYPE EBS

For Refrigerants 22, 134a, 404A, 507
Extended ODF Solder Connections

Sporlan Type EBS valve is a brass bar body valve having the same physical size as the Type S valve except the Type EBS features a balanced port construction and extended ODF connections. The thermostatic element is replaceable, and the inlet connection has a permanent 12 mesh strainer. The balanced port construction makes this valve ideally suited for refrigeration and air conditioning applications which operate over widely varying conditions.

Outlet Connections
7/8" ODF, 1-1/8" ODF, 1-3/8" ODF

Mating Distributors (See Bulletin 20-10)
1112, 1113, 1115, 1116, 1117, 1126, 1128, 1653(R), 1655(R), 1657(R)

For complete details of construction, see page 35.

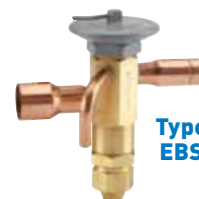

SPECIFICATIONS ELEMENT SIZE NO. 83, KNIFE EDGE JOINT

REFRIGERANT (Sporlan Code)	VALVE TYPE	NOMINAL CAPACITY Tons of Refrigeration	THERMOSTATIC CHARGES AVAILABLE	STANDARD TUBING LENGTH	CONNECTIONS - Inches ③			NET WEIGHT	SHIPPING WEIGHT
	External Equalizer				INLET	OUTLET	EXTERNAL EQUALIZER		
22 (V) 407C (N) 407A (V) 422D (V)	EBSVE-8 ②	8	*Refer to Recommended Thermostatic Charges on page 3	5 ft. 1.5 m	1/2 or 5/8	7/8 or 1-1/8	1/4 Pointed Toward Bottom Cap or Parallel to Outlet Connection	2 lbs. 0.90 kg	3 lbs. 1.36 kg
	EBSVE-11 ②	11			1/2, 5/8 or 7/8	7/8, 1-1/8 or 1-3/8			
	EBSVE-15	15			5/8 or 7/8	7/8, 1-1/8 or 1-3/8			
	EBSVE-20	20			7/8	1-1/8 or 1-3/8			
134a (J) 12 (F) 401A (X) 409A (F)	EBSJE-5 ②	5			1/2 or 5/8	7/8 or 1-1/8			
	EBSJE-7 ②	7			1/2, 5/8 or 7/8	7/8, 1-1/8 or 1-3/8			
	EBSJE-9	9			5/8 or 7/8	7/8, 1-1/8 or 1-3/8			
	EBSJE-12	12			7/8	1-1/8 or 1-3/8			
404A (S) 502 (R) 408A (R)	EBSSE-6 ②	6			1/2 or 5/8	7/8 or 1-1/8			
	EBSSE-7-1/2 ②	7-1/2			1/2, 5/8 or 7/8	7/8, 1-1/8 or 1-3/8			
	EBSSE-10	10			5/8 or 7/8	7/8, 1-1/8 or 1-3/8			
	EBSSE-13	13			7/8	1-1/8 or 1-3/8			
507 (P) 402A (L)	EBSPE-6 ②	6			1/2 or 5/8	7/8 or 1-1/8			
	EBSPE-7-1/2 ②	7-1/2	1/2, 5/8 or 7/8	7/8, 1-1/8 or 1-3/8					
	EBSPE-10	10	5/8 or 7/8	7/8, 1-1/8 or 1-3/8					
	EBSPE-13	13	7/8	1-1/8 or 1-3/8					

① ODF Solder indicates a female connection on the valve of proper diameter to receive copper tubing of corresponding OD size. Thus 5/8" ODF will receive 5/8" OD tubing.

② Approved for bi-directional applications.

③ Minimum quantities may apply to non-standard connections. Not all connection combinations are available.

* X charge not available.

DIMENSIONS

CONNECTIONS - Inches

FITTING SIZE	A	B	C
1/2	2.49	-	0.40
5/8	2.46	-	0.50
7/8	2.46	2.53	0.78
1-1/8	-	2.53	0.91
1-3/8	-	3.04	0.97

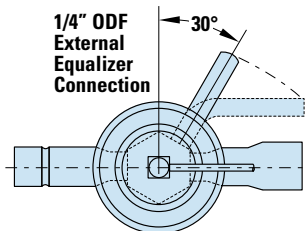

Top View

BULB SIZES - Inches

STANDARD CHARGES	REFRIGERANT			
	22	134a	404A	507
C	0.50 OD x 3.50			
Z & ZP Series	0.50 OD x 3.50	-	0.50 OD x 3.50	
CP Series	0.50 OD x 3.50			-
VGA	0.75 OD x 2.00	-	-	-

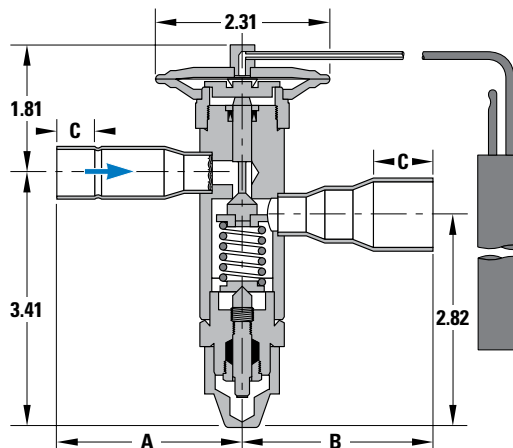

▼ TYPE O

For Refrigerants 22, 134a, 404A, 410A, 507
ODF Solder Connections

Sporlan Type O valve is a brass bar body, externally adjustable valve with ODF solder connections. The thermostatic element is replaceable, and the inlet connection has a permanent 12 mesh strainer. This valve type features a balanced port construction, and it is designed for both air conditioning and refrigeration applications. A synthetic seating surface provides tight shut-off during system off periods.

This valve type has two body styles: a small body which provides capacities up to 30 tons R-22 and

35 tons R-410A, and a large body which extends capacities to 70 tons R-22 and 60 tons R-410A.

Outlet Connections

1-1/8" ODF, 1-3/8" ODF, 1-5/8" ODF

Mating Distributors (See Bulletin 20-10)

1115, 1116, 1117, 1125, 1126, 1127, 1128, 1143, 1655(R), 1657(R), 1659(R)

For complete details of construction, see page 35.

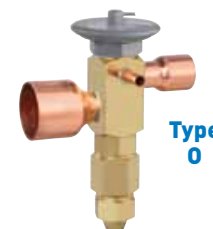

SPECIFICATIONS ELEMENT SIZE NO. 83, NO. 33, NO. 85 (R-410A), AND NO. 85-3 (R-410A), KNIFE EDGE JOINT

REFRIGERANT (Sporlan Code)	VALVE TYPE		THERMOSTATIC ELEMENT SIZE NO.	THERMOSTATIC CHARGES AVAILABLE	STANDARD TUBING LENGTH	CONNECTIONS - Inches ① ODF Solder		NET WEIGHT	SHIPPING WEIGHT		
	External Equalizer	NOMINAL CAPACITY Tons of Refrigeration				Blue figures are standard and will be furnished unless otherwise specified.					
						INLET	OUTLET				
22 (V) 407C (N) 407A (V) 422D (V)	OVE-15 ②	15	83	* Refer to Recommended Thermostatic Charges on page 3	5 feet 1.5 m	7/8	1-1/8	2 lbs. 0.90 kg	3 lbs. 1.36 kg		
	OVE-20 ②	20					1-3/8				
	OVE-30 ②	30				33	1-1/8	1-3/8 or 1-5/8	4 lbs. 1.82 kg	5 lbs. 2.27 kg	
	OVE-40	40									
	OVE-55	55	7/8				1-1/8	2 lbs. 0.90 kg	3 lbs. 1.36 kg		
OVE-70	70	1-3/8									
134a (J) 12 (F) 401A (X) 409A (F)	OJE-9	9	83			* Refer to Recommended Thermostatic Charges on page 3	5 feet 1.5 m	7/8	1-1/8	2 lbs. 0.90 kg	3 lbs. 1.36 kg
	OJE-12	12							1-3/8		
	OJE-16	16	33					1-1/8	1-3/8 or 1-5/8	4 lbs. 1.82 kg	5 lbs. 2.27 kg
	OJE-23	23									
	OJE-32	32		7/8	1-1/8			2 lbs. 0.90 kg	3 lbs. 1.36 kg		
OJE-40	40	1-3/8									
404A (S) 502 (R) 408A (R)	OSE-9	9	83	* Refer to Recommended Thermostatic Charges on page 3	5 feet 1.5 m			7/8	1-1/8	2 lbs. 0.90 kg	3 lbs. 1.36 kg
	OSE-12	12							1-3/8		
	OSE-21	21	33					1-1/8	1-3/8 or 1-5/8	4 lbs. 1.82 kg	5 lbs. 2.27 kg
	OSE-30	30									
	OSE-35	35				7/8	1-1/8	2 lbs. 0.90 kg	3 lbs. 1.36 kg		
OSE-45	45	1-3/8									
410A (Z)	OZE-20 ②	20	85			* Refer to Recommended Thermostatic Charges on page 3	5 feet 1.5 m	7/8	1-1/8	2 lbs. 0.90 kg	3 lbs. 1.36 kg
	OZE-25 ②	25							1-3/8		
	OZE-35 ②	35	85-3					1-1/8	1-3/8	4 lbs. 1.82 kg	5 lbs. 2.27 kg
	OZE-50	50									
OZE-60	60	83	7/8	1-1/8	2 lbs. 0.90 kg			3 lbs. 1.36 kg			
OPE-9	9			1-3/8							
OPE-12	12		33	1-1/8	1-3/8 or 1-5/8			4 lbs. 1.82 kg	5 lbs. 2.27 kg		
OPE-21	21										
OPE-30	30			7/8	1-1/8			2 lbs. 0.90 kg	3 lbs. 1.36 kg		
OPE-35	35	1-3/8									
OPE-45	45										

① ODF Solder indicates a female connection on the valve of proper diameter to receive copper tubing of corresponding OD size. Thus 5/8" ODF will receive 5/8" OD tubing.

② Optional bi-directional feature is available, please contact Sporlan Division of Parker for more information.

* X charge not available.

▼ TYPE 0

For Refrigerants 22, 134a, 404A, 410A, 507
ODF Solder Connections

TYPE 0 with NUMBER 83 and 85 ELEMENT

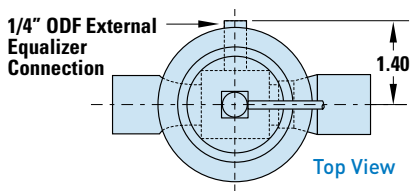

DIMENSIONS

CONNECTIONS - Inches

STRAIGHT THRU ODF SOLDER	A	B	C
7/8	2.09	2.08	0.78
1-1/8	2.21	2.23	0.91
1-3/8	-	2.39	0.97

BULB SIZES - Inches

STANDARD CHARGES	REFRIGERANT				
	22	134a	404A	410A	507
C	-	0.50 OD X 3.50	-	-	0.50 OD X 3.50
Z & ZP Series	0.50 OD X 3.50	-	0.50 OD X 3.50	-	0.50 OD X 3.50
CP Series	-	0.50 OD X 3.50	-	-	-
GA	0.75 OD X 2.00	-	-	0.75 OD X 2.00	-

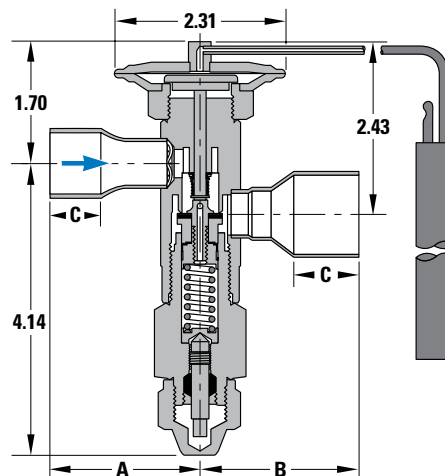

TYPE 0 with NUMBER 33 and 85-3 ELEMENT

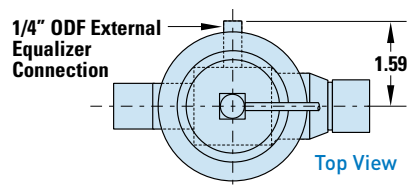

DIMENSIONS

CONNECTIONS - Inches

STRAIGHT THRU ODF SOLDER	A	B	C
1-1/8	2.69	-	0.91
1-3/8	-	2.84	0.97
1-5/8	-	3.12	1.09

BULB SIZES - Inches

STANDARD CHARGES	REFRIGERANT				
	22	134a	404A	410A	507
C	0.75 OD x 4.00	0.50 OD x 5.00	0.75 OD x 4.00	-	0.75 OD x 4.00
Z & ZP Series	0.75 OD x 4.00	-	0.75 OD x 4.00	-	0.75 OD x 4.00
CP Series	-	0.75 OD x 4.00	-	-	-
GA	0.75 OD x 4.00	-	-	0.75 OD X 2.00	-

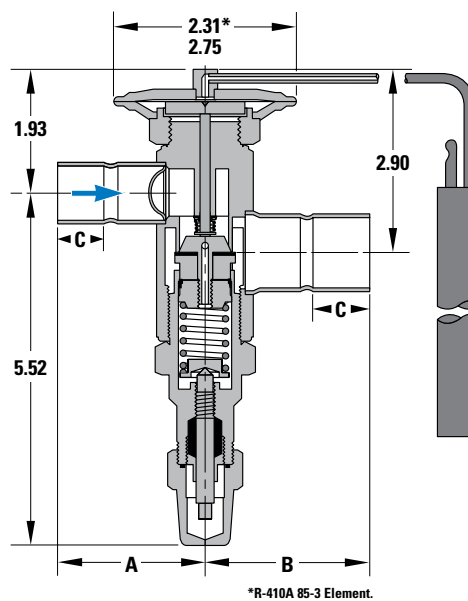

*R-410A 85-3 Element.

▼ TYPE H

For Refrigerants 22, 134a, 404A, 507
ODF Solder - Flange Connections

Sporlan Type H valve is a brass bar body, externally adjustable valve available with either ODF solder or FPT flange connections. The thermostatic element is replaceable, and the inlet connection has a permanent 16 mesh strainer. The FPT flange connection requires the Sporlan K-1178 adapter kit. This valve type provides the smallest capacity TEVs with flange connections, and it is designed for both air conditioning and refrigeration applications.

Outlet Connections
7/8" ODF, 1-1/8" ODF, "H" flange type

Mating Distributors (See Bulletin 20-10)
1109, 1110, 1112, 1113, 1115, 1116, 1124,
1192 (aluminum), 1653(R), 1655(R)

For complete details of construction, see page 35.



SPECIFICATIONS ELEMENT SIZE NO. 33, KNIFE EDGE JOINT

REFRIGERANT (Sporlan Code)	VALVE TYPE			NOMINAL CAPACITY Tons of Refrigeration	THERMOSTATIC CHARGES AVAILABLE	STANDARD TUBING LENGTH	CONNECTIONS - Inches ③ ODF Solder Blue figures are standard and will be furnished unless otherwise specified.		FLANGE RING SIZE OD x ID Inches ④	NET WEIGHT	SHIPPING WEIGHT								
	Internal Equalizer ①	External Equalizer ②										INLET	OUTLET						
22 (V) 407C (N) 407A (V) 422D (V)	HV-5-1/2	HVE-5-1/2	5-1/2	Refer to Recommended Thermostatic Charges on page 3	5 ft. 1.5 m	5/8 or 7/8	7/8 or 1-1/8	1.25 x 1.00	5 lbs. 2.27 kg	6 lbs. 2.72 kg									
	-	HVE-7	7				7/8				7/8 or 1-1/8								
	-	HVE-11	11				5/8 or 7/8				7/8 or 1-1/8								
	-	HVE-16	16																
-	HVE-20	20	5/8 or 7/8			7/8 or 1-1/8													
HJ-3	HJE-3	3																	
HJ-4	HJE-4	4																	
HJ-5	HJE-5	5																	
134a (J) 12 (F) 401A (X) 409A (F)	-	HJE-8	8			Refer to Recommended Thermostatic Charges on page 3	5 ft. 1.5 m	5/8 or 7/8			7/8 or 1-1/8	1.25 x 1.00	5 lbs. 2.27 kg	6 lbs. 2.72 kg					
	-	HJE-12	12								5/8 or 7/8				7/8 or 1-1/8				
	HS-3	HSE-3	3																
	HS-4	HSE-4	4																
404A (S) 502 (R) 408A (R)	-	HSE-6-1/2	6-1/2	Refer to Recommended Thermostatic Charges on page 3	5 ft. 1.5 m			5/8 or 7/8	7/8 or 1-1/8	1.25 x 1.00	5 lbs. 2.27 kg	6 lbs. 2.72 kg							
	-	HSE-9	9						5/8 or 7/8						7/8 or 1-1/8				
	-	HSE-12	12																
	HP-3	HPE-3	3																
507 (P) 402A (L)	HP-4	HPE-4	4					Refer to Recommended Thermostatic Charges on page 3	5 ft. 1.5 m	5/8 or 7/8					7/8 or 1-1/8	1.25 x 1.00	5 lbs. 2.27 kg	6 lbs. 2.72 kg	
	-	HPE-6-1/2	6-1/2												5/8 or 7/8				7/8 or 1-1/8
	-	HPE-9	9																
	-	HPE-12	12																

① Valves listed in this column NOT AVAILABLE with MOP Type air conditioning charges.

② Standard External Equalizer Connection 1/4" SAE Flare, 1/4" ODF Solder connection available on request.

③ ODF Solder indicates a female connection on the valve of proper diameter to receive copper tubing of corresponding OD size. Thus, 5/8" ODF will receive 5/8" OD tubing.

④ Kit K-1178 with two brass bushings is available for two purposes: 1) To allow the current Type H valve to replace obsolete Types T and H with 1.125" x 0.75" flange rings by mating with the smaller flange ring bushings and/or distributors. 2) To allow the Type H to use 1/2" FPT connections — Part number 225-002 and 1/2" socket weld connections — Part number 580-000. Order the appropriate 1/2" connections and one K-1178 per valve.

DIMENSIONS

CONNECTIONS - Inches

SOLDERING BUSHING	A	B
1/2	2.00	0.88
5/8	2.00	0.88
7/8	2.00	0.88
1-1/8	2.06	0.94

BULB SIZES - Inches

STANDARD CHARGES	REFRIGERANT			
	22	134a	404A	507
C	0.75 OD x 4.00	0.50 OD x 5.00	0.75 OD x 4.00	-
Z & ZP Series	0.75 OD x 4.00	-	0.75 OD x 4.00	-
X	0.75 OD x 4.00	-	0.75 OD x 4.00	-
CP Series	-	0.75 OD x 4.00	-	-
VGA	0.75 OD x 4.00	-	-	-

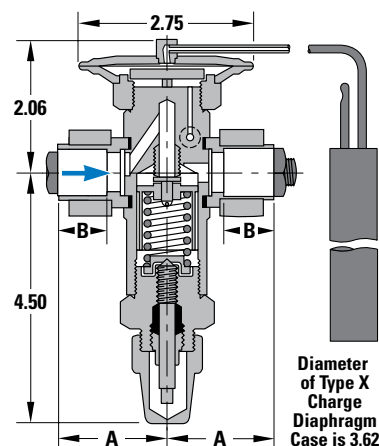

▼ TYPE M

For Refrigerants 22, 134a, 404A, 507
ODF Solder - Flange Connections

Sporlan Type M valve is a cast bronze body, externally adjustable valve with either ODF solder or FPT flange connections. The thermostatic element is replaceable, and the inlet connection has a permanent 12 mesh strainer. This valve type provides capacities greater than the Type H, and it is designed for both air conditioning and refrigeration applications. Flanges for the Type M valve are interchangeable with the Type V.

Outlet Connections

1-1/8" ODF, 1-3/8" ODF, 1-5/8" ODF, M/V flange

Mating Distributors (See Bulletin 20-10)

1115, 1116, 1117, 1119, 1121, 1125, 1126, 1127, 1128, 1143, 1193 (aluminum), 1655(R), 1657(R), 1659(R)

For complete details of construction, see page 35.



SPECIFICATIONS ELEMENT SIZE NO. 63, GASKET JOINT

REFRIGERANT (Sporlan Code)	VALVE TYPE		THERMOSTATIC CHARGES AVAILABLE	Blue figures are standard and will be furnished unless otherwise specified.			FLANGE RING SIZE OD x ID Inches	NET WEIGHT	SHIPPING WEIGHT												
	External Equalizer ①	NOMINAL CAPACITY Tons of Refrigeration		STANDARD TUBING LENGTH	② CONNECTIONS - Inches ③ ODF Solder Flange																
					INLET	OUTLET															
22 (V) 407C (N) 407A (V) 422D (V)	MVE-21	21	5 ft. 1.5 m	10 ft. 3 m	7/8 or 1-1/8	1-1/8 1-3/8 or 1-5/8	1.75 x 1.25	8 lbs. 3.63 kg	9 lbs. 4.09 kg												
	MVE-26	26																			
	MVE-34	34																			
	MVE-42	42																			
134a (J) 12 (F) 401A (X) 409A (F)	MJE-15	15			10 ft. 3 m					10 ft. 3 m	7/8 or 1-1/8	1-1/8 1-3/8 or 1-5/8	1.75 x 1.25	8 lbs. 3.63 kg	9 lbs. 4.09 kg						
	MJE-20	20																			
	MJE-25	25																			
404A (S) 502 (R) 408A (R)	MSE-15	15														10 ft. 3 m	10 ft. 3 m	7/8 or 1-1/8	1-1/8 1-3/8 or 1-5/8	1.75 x 1.25	8 lbs. 3.63 kg
	MSE-20	20																			
	MSE-25	25																			
MSE-30	30																				
507 (P) 402A (L)	MPE-15	15									10 ft. 3 m							10 ft. 3 m			
	MPE-20	20																			
	MPE-25	25																			
	MPE-30	30																			

① Standard External Equalizer Connection 1/4" SAE Flare, 1/4" ODF Solder connection available on request.
 ② FPT connections also available on request; 1/2" FPT - Part Number 360-000, 3/4" FPT - Part Number 360-001, 1" FPT - Part Number 362-000.
 ③ ODF Solder indicates a female connection on the valve of proper diameter to receive copper tubing of corresponding OD size. Thus, 7/8" ODF will receive 7/8" OD tubing.

DIMENSIONS

CONNECTIONS - Inches

SOLDERING BUSHING	A	B
7/8	2.38	0.88
1-1/8	2.75	0.94
1-3/8	2.75	0.94
1-5/8	3.22	1.22

BULB SIZES - Inches

STANDARD CHARGES	REFRIGERANT			
	22	134a	404A	507
C	0.88 OD x 6.00			
Z & ZP Series	0.88 OD x 6.00	-	0.88 OD x 6.00	-
X	0.88 OD x 6.00	-	0.88 OD x 6.00	-
CP Series	0.75 OD x 4.00			
VGA	0.75 OD x 4.00	-	-	-

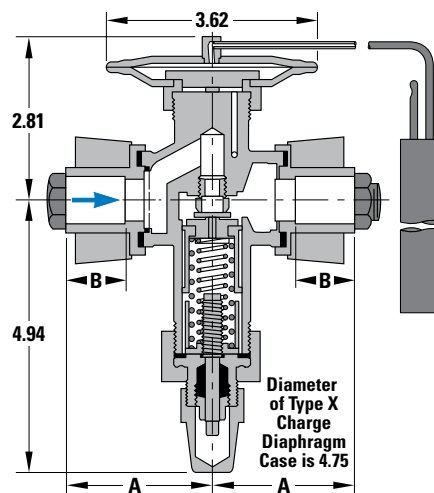

▼ TYPE V

For Refrigerants 22, 134a, 404A, 507
ODF Solder - Flange Connections

Sporlan Type V valve is a cast bronze body, externally adjustable valve available with either ODF solder or FPT flange connections. The thermostatic element is replaceable, and the inlet connection has a permanent 12 mesh strainer. This valve features a dual port semi-balanced design, and it is designed for both air conditioning and refrigeration applications. A synthetic seating surface provides tight shut-off during system off periods. This valve provides greater

capacities than the Type M. Flanges for the Type V valve are interchangeable with the Type M.

Outlet Connections

1-3/8" ODF, 1-5/8" ODF, M/V flange

Mating Distributors (See Bulletin 20-10)

1117, 1119, 1121, 1125, 1126, 1127, 1128, 1143,
1193 (aluminum), 1657(R), 1659(R)

For complete details of construction, see page 35.



SPECIFICATIONS ELEMENT SIZE NO. 63, GASKET JOINT

REFRIGERANT (Sporlan Code)	VALVE TYPE External Equalizer ①	NOMINAL CAPACITY Tons of Refrigeration	THERMOSTATIC CHARGES AVAILABLE	Blue figures are standard and will be furnished unless otherwise specified.			FLANGE RING SIZE OD x ID Inches	NET WEIGHT	SHIPPING WEIGHT
				STANDARD TUBING LENGTH	② CONNECTIONS - Inches ③ ODF Solder Flange				
					INLET	OUTLET			
22 (V) 407C (N) 407A (V) 422D (V)	VVE-52	52	Refer to Recommended Thermostatic Charges on page 3	5 ft. 1.5 m 10 ft. 3 m	1-1/8 or 1-3/8	1-1/8 1-3/8 or 1-5/8	1.75 x 1.25	9 lbs. 4.09 kg	10 lbs. 4.54 kg
	VVE-70	70							
	VVE-100	100							
134a (J) 12 (F) 401A (X) 409A (F)	VJE-35	35							
	VJE-45	45							
	VJE-55	55							
404A (S) 502 (R) 408A (R)	VSE-38	38							
	VSE-50	50							
	VSE-70	70							
507 (P) 402A (L)	VPE-38	38							
	VPE-50	50							
	VPE-70	70							

① Standard External Equalizer Connection 1/4" SAE Flare. 1/4" ODF Solder connection available on request.

② FPT connections also available on request; 1/2" FPT - Part Number 360-000, 3/4" FPT - Part Number 360-001, 1" FPT - Part Number 362-000.

③ ODF Solder indicates a female connection on the valve of proper diameter to receive copper tubing of corresponding OD size. Thus, 7/8" ODF will receive 7/8" OD tubing.

DIMENSIONS

CONNECTIONS - Inches

SOLDERING BUSHING	A	B
7/8	2.38	0.88
1-1/8	2.75	0.94
1-3/8	2.75	0.94
1-5/8	3.22	1.22

BULB SIZES - Inches

STANDARD CHARGES	REFRIGERANT			
	22	134a	404A	507
C	0.88 OD x 6.00			
Z & ZP Series	0.88 OD x 6.00	-	0.88 OD x 6.00	
X	0.88 OD x 6.00	-	0.88 OD x 6.00	
CP Series	0.75 OD x 4.00			-
VGA	0.75 OD x 4.00	-	-	-

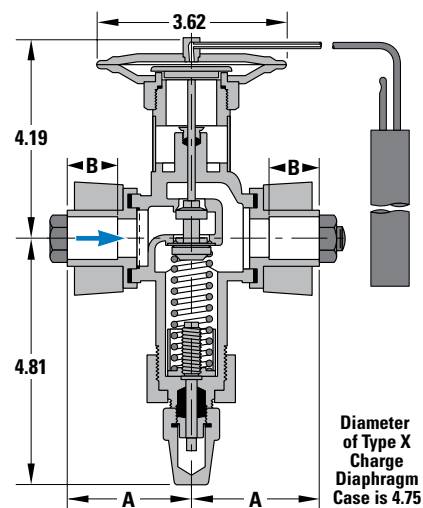

▼ TYPE W

For Refrigerants 22, 134a
ODF Solder - Flange Connections

Sporlan Type W valve is a cast bronze body, externally adjustable valve available with ODF solder flange connections. The thermostatic element is replaceable, and the inlet connection has a permanent 12 mesh strainer. This valve features a dual port semi-balanced design, and it is designed primarily for large capacity chillers. A synthetic seating surface provides tight shut-off during system off periods. This valve provides the largest capacities available for flange connection TEVs.

Outlet Connections
1-3/8" ODF, 1-5/8" ODF

Mating Distributors (See Bulletin 20-10)
1117, 1125, 1126, 1127, 1128, 1143, 1657(R), 1659(R)

For complete details of construction, see page 35.

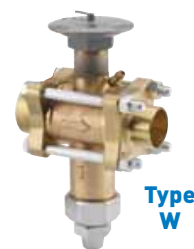

SPECIFICATIONS ELEMENT SIZE NO. 63 and 7, GASKET JOINT

REFRIGERANT (Sporlan Code)	VALVE TYPE External Equalizer ①	NOMINAL CAPACITY Tons of Refrigeration	THERMOSTATIC CHARGES AVAILABLE	ELEMENT SIZE NUMBER	Blue figures are standard and will be furnished unless otherwise specified.		FLANGE RING SIZE OD x ID Inches ④	NET WEIGHT	SHIPPING WEIGHT	
					STANDARD TUBING LENGTH	CONNECTIONS - Inches ② ODF Solder Flange				
						INLET				OUTLET
22 (V) 407C (N) 407A (V) 422D (V)	WVE-135	135	③	63	10 ft. 3 m	1-1/8	1-1/8	2.75 x 2.19	10 lbs. 4.54 kg	11 lbs. 4.99 kg
	WVE-180	180	G only	7		1-3/8	1-3/8			
134a (J) 12 (F) 401A (X) 409A (F)	WJE-80	80	③	63		1-5/8 or 2-1/8	1-5/8 or 2-1/8			
	WJE-110	110	G only	7						

① Standard External Equalizer Connection 1/4" SAE Flare, 1/4" ODF Solder connection available on request.
 ② ODF Solder indicates a female connection on the valve of proper diameter to receive copper tubing of corresponding OD size. Thus, 1-1/8" ODF will receive 1-1/8" OD tubing.
 ③ Refer to Recommended Thermostatic Charges, page 3.
 ④ For 1-1/2" NPT connections, order flanges separately for MA42 solenoid eg P/N 933-1. The customer must supply 5/8" diameter x 6" long bolts and 5/8" diameter nuts.

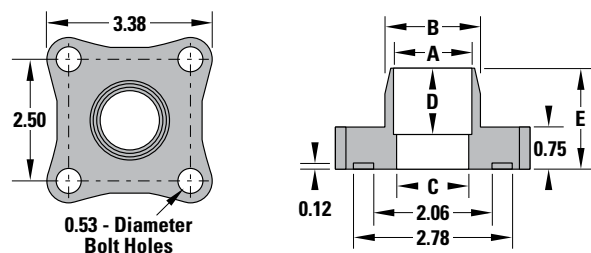

DIMENSIONS

CONNECTIONS - Inches

FITTING SIZE	A	B	C	D	E	F
1-1/8	1.12	1.27	1.06	0.91	1.56	3.09
1-3/8	1.38	1.53	1.28	0.97	1.62	3.16
1-5/8	1.62	1.78	1.50	1.09	1.75	3.28
2-1/8	2.12	2.44	1.94	1.34	1.53	3.25

BULB SIZES - Inches

STANDARD CHARGES	ELEMENT SIZE NUMBER	REFRIGERANT	
		22	134a
C	63	0.88 OD x 6.00	
Z & ZP Series		0.88 OD x 6.00	-
X		0.88 OD x 6.00	-
CP Series		0.75 OD x 4.00	
VGA	7	0.75 OD x 4.00	-
G		0.75 OD x 4.00	-

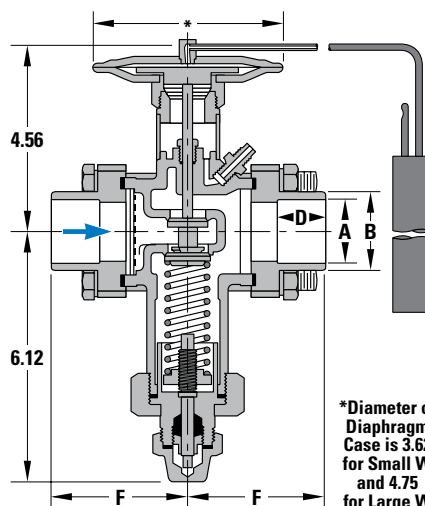







▼ MATERIALS & DETAILS OF CONSTRUCTION

VALVE TYPE	BODY	SEAT	PIN	PIN CARRIER	PUSHROD(S)	TYPE OF JOINTS	CONNECTIONS	INLET STRAINER
RC	Machined Brass Bar	Brass Port Machined in Body	Stainless Steel	–	Stainless Steel	Knife Edge to Metal	Chatleff, SAE Flare, ODF Copper Fittings Silver Soldered to Body	No Strainer
ER	Machined Brass Bar	Brass Port Machined in Body	Stainless Steel	–	Stainless Steel	Knife Edge to Metal	ODF Copper Fittings Silver Soldered to Body	No Strainer
F	Machined Brass Bar	Brass	Stainless Steel	Brass	Stainless Steel	Knife Edge to Metal	SAE Flare Fittings Silver Soldered to Body	Removable Strainer Screen
EF	Machined Brass Bar	Brass	Stainless Steel	Brass	Stainless Steel	Knife Edge to Metal	ODF Copper Fittings Silver Soldered to Body	Insert Strainer
Q/ BQ	Machined Brass Bar	Brass	Stainless Steel	Brass	Stainless Steel	Knife Edge to Metal	SAE Flare Fittings Silver Soldered to Body	Removable Strainer Screen
SQ/ SBQ	Machined Brass Bar	Brass	Stainless Steel	Brass	Stainless Steel	Knife Edge to Metal	ODF Copper Fittings Silver Soldered to Body	
EQ/ EBQ	Machined Brass Bar	Brass	Stainless Steel	Brass	Stainless Steel	Knife Edge to Metal	Extended Copper Fittings Silver Soldered to Body	Insert Strainer
G	Brass Forging	Brass	Stainless Steel	Brass	Internally Equalized: Triangular Stainless Steel Externally Equalized: Round Stainless Steel	Knife Edge to Metal	SAE Flare, Integral Part of Brass Forged Body	Removable Strainer Screen
EG	Brass Forging	Brass	Stainless Steel	Brass		Knife Edge to Metal	ODF Copper Fittings Silver Soldered to Body	
S	Machined Brass Bar	Brass	Stainless Steel	Brass		Knife Edge to Metal	ODF Copper Fittings Silver Soldered to Body	Coarse Mesh Strainer Disc
BF	Machined Brass Bar	Brass	Stainless Steel	–	Stainless Steel	Knife Edge to Metal	SAE Flare Fittings Silver Soldered to Body	Removable Strainer Screen
SBF	Machined Brass Bar	Brass	Stainless Steel	–	Stainless Steel	Knife Edge to Metal	ODF Copper Fittings Silver Soldered to Body	
EBF	Machined Brass Bar	Brass	Stainless Steel	–	Stainless Steel	Knife Edge to Metal	Extended Copper Fittings Silver Soldered to Body	Insert Strainer
EBS	Machined Brass Bar	Brass Port Machined in Body	Stainless Steel	–	Stainless Steel	Knife Edge to Metal	ODF Copper Fittings Silver Soldered to Body	Coarse Mesh Strainer Disc
SMALL O	Machined Brass Bar	Brass Port Machined in Body	Brass Piston With Synthetic Seating Surface	–	Stainless Steel	Knife Edge to Metal	ODF Copper Fittings Silver Soldered to Body	Coarse Mesh Strainer Disc
LARGE O	Machined Brass Bar	Brass Port Machined in Body		–	Stainless Steel	Knife Edge At Element and Bottom Cap Gasket At Seal Cap	ODF Copper Fittings Silver Soldered to Body	Coarse Mesh Strainer Disc
H	Machined Brass Bar	Stainless Steel or Brass	Stainless Steel	Brass	Stainless Steel	Bottom Cap Gasket At Seal Cap	Solder-Flange, Pipe Flange	Coarse Mesh Strainer Disc
M	Bronze Casting	Stainless Steel or Brass	Stainless Steel	Brass	Stainless Steel	Gasket	Solder-Flange, Pipe Flange	Coarse Mesh Strainer Disc
V	Bronze Casting	Dual Port, Seats Machined in Valve Body	Bronze Piston With Synthetic Sealing Surface	–	Stainless Steel	Gasket	Solder-Flange, Pipe Flange	Coarse Mesh Strainer Disc
W	Bronze Casting			–	Stainless Steel	Gasket	Solder-Flange, Pipe Flange	Coarse Mesh Strainer Disc

NOTE: Materials and Construction specifications listed on this page may change without notice. Contact Sporlan Division of Parker for current specifications on materials and other details of construction.

▼ OEM TYPE THERMOSTATIC EXPANSION VALVES

In addition to the standard line of Thermostatic Expansion Valves listed in this bulletin, special valve types are also available to fill manufacturers' specific requirements. Listed below are examples of valves that are supplied for quantity orders.

VALVE TYPE	CONNECTION TYPE	VALVE DESCRIPTION and APPLICATION	TYPICAL REPLACEMENT TEVs
BI*/BBI  * BI is OBSOLETE.	SAE Flare or ODF Solder	Small brass body valve available with either angle style or straight through connections. Type BI valves with straight through connections are normally supplied non-adjustable. The Type BBI is a Type BI valve modified to incorporate balanced port construction. The thermostatic element is not replaceable on valves manufactured prior to 1994. Current models use a replaceable No. 43 element. Typical applications: small capacity R-22 air conditioning and heat pump systems.	ER, RC, G, EG, S, Q, SQ, EQ, BQ, SBQ, EBQ
Y997-BI  OBSOLETE	SAE Flare or ODF Solder	Type BI valve modified to incorporate an internal check valve and bypass tube to allow for reverse flow with heat pump applications. The valve is not adjustable. The thermostatic element is not replaceable on valves manufactured prior to 1994. Current models use a replaceable No. 43 element. Typical applications: small capacity R-22 heat pump systems.	RC, G, EG, S, Q, SQ, EQ, BQ, SBQ, EBQ Note: A check valve may be required for install around the TEV to allow flow in the reverse direction.
I  OBSOLETE	SAE Flare or ODF Solder	Small brass body valve available with either angle style or straight through connections. Type I valves with straight through connections are normally supplied non-adjustable. Current models use a replaceable No. 43 element. This valve is available with the Rapid Pressure Balancer (RPB) feature for off-cycle pressure equalization. Typical applications: small capacity R-22 air conditioning and heat pump systems.	ER, RC, G, EG, S, Q, SQ, EQ, BQ, SBQ, EBQ
CBI*/CBBI  * CBI is OBSOLETE.	SAE Flare or ODF Solder	Type BI/BBI valves modified to incorporate an internal check valve to allow for reverse flow with heat pump applications. Type CBI/CBBI valves with straight through connections are normally supplied non-adjustable. The valve uses a replaceable No. 43 element. Typical applications: small capacity R-22 heat pump systems.	RC, G, EG, S, Q, SQ, EQ, BQ, SBQ, EBQ Note: A check valve may be required for install around the TEV to allow flow in the reverse direction.
FB  OBSOLETE	SAE Flare or ODF Solder	Small brass body valve available only with straight through connections and external adjustment. The thermostatic element is not replaceable on valves manufactured prior to 1994. Current models use a replaceable No. 43 element. Typical applications: small capacity air conditioning and refrigeration applications where an external adjustment is desired.	ER, RC, G, EG, S, Q, SQ, EQ, BQ, SBQ, EBQ
X  OBSOLETE	SAE Flare or ODF Solder	Brass body valve available with either angle style or straight through connections. Angle style valve is available only with SAE flare connections. Type X valves with straight through connections are normally supplied non-adjustable. The thermostatic element is a replaceable type, size number 53. This valve is available with the Rapid Pressure Balancer (RPB) feature in certain nominal capacities for off-cycle pressure equalization. Typical applications: R-22 air conditioning and heat pump systems.	ER, RC, G, EG, S, Q, SQ, EQ, BQ, SBQ, EBQ

FEATURES NOT INCLUDED IN THIS BULLETIN

Special features such as non-adjustable construction or similar modifications are also available for both standard and special valves when ordered in reasonable quantities.

Automatic (constant pressure) expansion valves are also available on special order.

If you have a special valve application, contact your Sporlan Sales Engineer or Sporlan Division, Parker Hannifin, 206 Lange Drive, Washington, Missouri 63090, 636-239-1111.

OFFER OF SALE

The items described in this document and other documents and descriptions provided by Parker Hannifin Corporation, its subsidiaries and its authorized distributors ("Seller") are hereby offered for sale at prices to be established by Seller. This offer and its acceptance by any customer ("Buyer") shall be governed by all of the following Terms and Conditions. Buyer's order for any item described in its document, when communicated to Seller verbally, or in writing, shall constitute acceptance of this offer. All goods or work described will be referred to as "Products".

- 1. Terms and Conditions.** Seller's willingness to offer Products, or accept an order for Products, to or from Buyer is expressly conditioned on Buyer's assent to these Terms and Conditions and to the terms and conditions found on-line at www.parker.com/saleterms/. Seller objects to any contrary or additional term or condition of Buyer's order or any other document issued by Buyer.
- 2. Price Adjustments; Payments.** Prices stated on the reverse side or preceding pages of this document are valid for 30 days. After 30 days, Seller may change prices to reflect any increase in its costs resulting from state, federal or local legislation, price increases from its suppliers, or any change in the rate, charge, or classification of any carrier. The prices stated on the reverse or preceding pages of this document do not include any sales, use, or other taxes unless so stated specifically. Unless otherwise specified by Seller, all prices are F.O.B. Seller's facility, and payment is due 30 days from the date of invoice. After 30 days, Buyer shall pay interest on any unpaid invoices at the rate of 1.5% per month or the maximum allowable rate under applicable law.
- 3. Delivery Dates: Title and Risk; Shipment.** All delivery dates are approximate and Seller shall not be responsible for any damages resulting from any delay. Regardless of the manner of shipment, title to any products and risk of loss or damage shall pass to Buyer upon tender to the carrier at Seller's facility (i.e., when it's on the truck, it's yours). Unless otherwise stated, Seller may exercise its judgment in choosing the carrier and means of delivery. No deferment of shipment at Buyers' request beyond the respective dates indicated will be made except on terms that will indemnify, defend and hold Seller harmless against all loss and additional expense. Buyer shall be responsible for any additional shipping charges incurred by Seller due to Buyer's changes in shipping, product specifications or in accordance with Section 13, herein.
- 4. Warranty.** Seller warrants that the Products sold hereunder shall be free from defects in material or workmanship for a period of twelve months from the date of delivery to Buyer or 2,000 hours of normal use, whichever occurs first. This warranty is made only to Buyer and does not extend to anyone to whom Products are sold after purchased from Seller. The prices charged for Seller's products are based upon the exclusive limited warranty stated above, and upon the following disclaimer: **DISCLAIMER OF WARRANTY: THIS WARRANTY COMPRISES THE SOLE AND ENTIRE WARRANTY PERTAINING TO PRODUCTS PROVIDED HEREUNDER. SELLER DISCLAIMS ALL OTHER WARRANTIES, EXPRESS AND IMPLIED, INCLUDING MERCHANTABILITY AND FITNESS FOR A PARTICULAR PURPOSE.**
- 5. Claims; Commencement of Actions.** Buyer shall promptly inspect all Products upon delivery. No claims for shortages will be allowed unless reported to the Seller within 10 days of delivery. No other claims against Seller will be allowed unless asserted in writing within 60 days after delivery or, in the case of an alleged breach of warranty, within 30 days after the date within the warranty period on which the defect is or should have been discovered by Buyer. Any action based upon breach of this agreement or upon any other claim arising out of this sale (other than an action by Seller for any amount due to Seller from Buyer) must be commenced within thirteen months from the date of tender of delivery by Seller or, for a cause of action based upon an alleged breach of warranty, within thirteen months from the date within the warranty period on which the defect is or should have been discovered by Buyer.
- 6. LIMITATION OF LIABILITY.** UPON NOTIFICATION, SELLER WILL, AT ITS OPTION, REPAIR OR REPLACE A DEFECTIVE PRODUCT, OR REFUND THE PURCHASE PRICE. **IN NO EVENT SHALL SELLER BE LIABLE TO BUYER FOR ANY SPECIAL, INDIRECT, INCIDENTAL OR CONSEQUENTIAL DAMAGES ARISING OUT OF, OR AS THE RESULT OF, THE SALE, DELIVERY, NON-DELIVERY, SERVICING, USE OR LOSS OF USE OF THE PRODUCTS OR ANY PART THEREOF, OR FOR ANY CHARGES OR EXPENSES OF ANY NATURE INCURRED WITHOUT SELLER'S WRITTEN CONSENT, EVEN**

IF SELLER HAS BEEN NEGLIGENT, WHETHER IN CONTRACT, TORT OR OTHER LEGAL THEORY. IN NO EVENT SHALL SELLER'S LIABILITY UNDER ANY CLAIM MADE BY BUYER EXCEED THE PURCHASE PRICE OF THE PRODUCTS.

- 7. Contingencies.** Seller shall not be liable for any default or delay in performance if caused by circumstances beyond the reasonable control of Seller.
- 8. User Responsibility.** The user, through its own analysis and testing, is solely responsible for making the final selection of the system and Product and assuring that all performance, endurance, maintenance, safety and warning requirements of the application are met. The user must analyze all aspects of the application and follow applicable industry standards and Product information. If Seller provides Product or system options, the user is responsible for determining that such data and specifications are suitable and sufficient for all applications and reasonably foreseeable uses of the Products or systems.
- 9. Loss to Buyer's Property.** Any designs, tools, patterns, materials, drawings, confidential information or equipment furnished by Buyer or any other items which become Buyer's property, may be considered obsolete and may be destroyed by Seller after two consecutive years have elapsed without Buyer placing an order for the items which are manufactured using such property. Seller shall not be responsible for any loss or damage to such property while it is in Seller's possession or control.
- 10. Special Tooling.** A tooling charge may be imposed for any special tooling, including without limitation, dies, fixtures, molds and patterns, acquired to manufacture Products. Such special tooling shall be and remain Seller's property notwithstanding payment of any charges by Buyer. In no event will Buyer acquire any interest in apparatus belonging to Seller which is utilized in the manufacture of the Products, even if such apparatus has been specially converted or adapted for such manufacture and notwithstanding any charges paid by Buyer. Unless otherwise agreed, Seller shall have the right to alter, discard or otherwise dispose of any special tooling or other property in its sole discretion at any time.
- 11. Buyer's Obligation; Rights of Seller.** To secure payment of all sums due or otherwise, Seller shall retain a security interest in the goods delivered and this agreement shall be deemed a Security Agreement under the Uniform Commercial Code. Buyer authorizes Seller as its attorney to execute and file on Buyer's behalf all documents Seller deems necessary to perfect its security interest. Seller shall have a security interest in, and lien upon, any property of Buyer in Seller's possession as security for the payment of any amounts owed to Seller by Buyer.
- 12. Improper use and Indemnity.** Buyer shall indemnify, defend, and hold Seller harmless from any claim, liability, damages, lawsuits, and costs (including attorney fees), whether for personal injury, property damage, patent, trademark or copyright infringement or any other claim, brought by or incurred by Buyer, Buyer's employees, or any other person, arising out of: (a) improper selection, improper application or other misuse of Products purchased by Buyer from Seller; (b) any act or omission, negligent or otherwise, of Buyer; (c) Seller's use of patterns, plans, drawings, or specifications furnished by Buyer to manufacture Product; or (d) Buyer's failure to comply with these terms and conditions. Seller shall not indemnify Buyer under any circumstance except as otherwise provided.
- 13. Cancellations and Changes.** Orders shall not be subject to cancellation or change by Buyer for any reason, except with Seller's written consent and upon terms that will indemnify, defend and hold Seller harmless against all direct, incidental and consequential loss or damage. Seller may change product features, specifications, designs and availability with notice to Buyer.
- 14. Limitation on Assignment.** Buyer may not assign its rights or obligations under this agreement without the prior written consent of Seller.
- 15. Entire Agreement.** This agreement contains the entire agreement between the Buyer and Seller and constitutes the final, complete and exclusive expression of the terms of the agreement. All prior

or contemporaneous written or oral agreements or negotiations with respect to the subject matter are herein merged.

16. Waiver and Severability. Failure to enforce any provision of this agreement will not waive that provision nor will any such failure prejudice Seller's right to enforce that provision in the future. Invalidation of any provision of this agreement by legislation or other rule of law shall not invalidate any other provision herein. The remaining provisions of this agreement will remain in full force and effect.

17. Termination. This agreement may be terminated by Seller for any reason and at any time by giving Buyer thirty (30) days written notice of termination. In addition, Seller may by written notice immediately terminate this agreement for the following: (a) Buyer commits a breach of any provision of this agreement (b) the appointment of a trustee, receiver or custodian for all or any part of Buyer's property (c) the filing of a petition for relief in bankruptcy of the other Party on its own behalf, or by a third party (d) an assignment for the benefit of creditors, or (e) the dissolution or liquidation of the Buyer.

18. Governing Law. This agreement and the sale and delivery of all Products hereunder shall be deemed to have taken place in and shall be governed and construed in accordance with the laws of the State of Ohio, as applicable to contracts executed and wholly performed therein and without regard to conflicts of laws principles. Buyer irrevocably agrees and consents to the exclusive jurisdiction and venue of the courts of Cuyahoga County, Ohio with respect to any dispute, controversy or claim arising out of or relating to this agreement. Disputes between the parties shall not be settled by arbitration unless, after a dispute has arisen, both parties expressly agree in writing to arbitrate the dispute.

19. Indemnity for Infringement of Intellectual Property Rights. Seller shall have no liability for infringement of any patents, trademarks, copyrights, trade dress, trade secrets or similar rights except as provided in this Section. Seller will defend and indemnify Buyer against allegations of infringement of U.S. patents, U.S. trademarks, copyrights, trade dress and trade secrets ("Intellectual Property Rights"). Seller will defend at its expense and will pay the cost of any settlement or damages awarded in an action brought against Buyer based on an allegation that a Product sold pursuant to this Agreement infringes the Intellectual Property Rights of a third party. Seller's obligation to defend and indemnify Buyer is contingent on Buyer notifying Seller within ten (10) days after Buyer becomes aware of such allegations of infringement, and Seller having sole control over the defense of any allegations or actions including all negotiations for settlement or compromise. If a Product is subject to a claim that it infringes the Intellectual Property Rights of a third party, Seller may, at its sole expense and option, procure for Buyer the right to continue using the Product, replace or modify the Product so as to make it noninfringing, or offer to accept return of the Product and return the purchase price less a reasonable allowance for depreciation. Notwithstanding the foregoing, Seller shall have no liability for claims of infringement based on information provided by Buyer, or directed to Products delivered hereunder for which the designs are specified in whole or part by Buyer, or infringements resulting from the modification, combination or use in a system of any Product sold hereunder. The foregoing provisions of this Section shall constitute Seller's sole and exclusive liability and Buyer's sole and exclusive remedy for infringement of Intellectual Property Rights.

20. Taxes. Unless otherwise indicated, all prices and charges are exclusive of excise, sales, use, property, occupational or like taxes which may be imposed by any taxing authority upon the manufacture, sale or delivery of Products.

21. Equal Opportunity Clause. For the performance of government contracts and where dollar value of the Products exceed \$10,000, the equal employment opportunity clauses in Executive Order 11246, VEVRRA, and 41 C.F.R. §§ 60-1.4(a), 60-741.5(a), and 60-250.4, are hereby incorporated.



Parker Hannifin Corporation
Sporlan Division
206 Lange Drive • Washington, MO 63090 USA
phone 636 239 1111 • fax 636 239 9130
www.sporlan.com