



# INDUSTRIAL HOSES

Catalogue





# Detailed table of Contents

Alphabetical Index	IV
Index by Application	V
Partnumber Index	VI

## Promotional pages

Global hose	13
Silicone Hose	14
E-Z Form	14
Barrier Hose	15
POLIAX range	16
GAMBRINUS range	17
Low Temperature Hose	

## Technical Handbook

























































Hose Selection Matrix	TH4
Hose Part Number Description	TH8
Parker Safety Guide	TH37

## Hose Technical Specification

 Oil & Fuel	A
 Automotive	B
 Gas	C
 Water	D
 Hot Water & Steam	E
 Acid & Chemicals	F
 Material Handling	G
 Beverage & Food	H
 Multipurpose & Air	I







































We reserve the right to modify whenever necessary the features and specifications of the products included in this publication without prior notice.









































# Alphabetical Index

<b>A</b>	<b>Page</b>	<b>I</b>	<b>Page</b>	<b>T</b>	<b>Page</b>
 AIRBRAKE DIN 74310	B8	 IDRO 10	D4	 TBE	B11
 APERFRUT 20	I13			 TBSE	B10
 APERFRUT 40	I13	<b>J</b>	<b>Page</b>	 THERMOPRESS 10	E7
 APERFRUT 80	I13	 JUMBO N/L	I9	<b>V</b>	<b>Page</b>
 APERSPIR	H10			 VIGOR 2 EN ISO 6134 TYPE 2/A	E8
 ASPIREX	G7	<b>L</b>	<b>Page</b>	 VINITRESS	H9
 AUTOGENE EN ISO 3821 NR/L - NB/L 20	C4	 LIBECCIO EN ISO 3861	G4		
<b>B</b>	<b>Page</b>	<b>M</b>	<b>Page</b>	<b>W</b>	<b>Page</b>
 BETON 80	G5	 MINIERA 20 MSHA	I10	 WAVEMASTER™	B13
 BEVERA 10	D5				
<b>C</b>	<b>Page</b>	<b>O</b>	<b>Page</b>		
 CARBOBLUE N/L 20	B12	 OILPRESS N/L 20	I12		
 CARBOCORD EN 12115	A6			<b>P</b>	<b>Page</b>
 CARBOPRESS N/L 10	A4			 POLIAX D EN 12115	F4
 CARBURITE 10	A5			 POLIAX D SM EN 12115	F5
 CERGOM	G6			 POLIAX F EN 12115	F8
 CERVINO EN 12115	A8			 POLIAX PHARMA	F9
 CHEMIOEL EN 12115	A7			 POLIAX UPE CON SM EN 12115	F6
				 POLIAX UPE CON SM EN 12115 OND	F7
				 PROPANPRESS EN ISO 3821 NAVL 20	C5
<b>D</b>	<b>Page</b>	 PYTHON NV/L 20	I7	 PYTHON NY/L 30	I8
 DRINKPRESS WB/L 10	H4				
<b>E</b>	<b>Page</b>			<b>R</b>	<b>Page</b>
 E-Z FORM™ GS	B5			 RADIOR 10	B4
 E-Z FORM™ HT	A9			 RADIOR 3 (COIL)	E4
 E-Z FORM™ MP	I11			 RADIOR 3 (CUT LENGTH)	E5
				 RADIOR DIN 6	B6
				 RADIOR K 1003	E6
<b>G</b>	<b>Page</b>	<b>S</b>	<b>Page</b>		
 GAMBRINUS BLUE 10	H6	 SERIES 395 SAE J 30R7	B9		
 GAMBRINUS BLUE SM 10	H7	 SERIES 6722	B7		
 GAMBRINUS RED SM 10	H8	 SM/TR 311	B14		
 GAMBRINUS UPE SM EN12115	H5	 SUPER-FLEX® FL	B15		
 GST II BLACK 15	I4	 SUPER-FLEX® FL-7	B14		
 GST II BLACK 20	I6				
 GST II RED 15	I5				



# Partnumber Index

Partnumber (IH+6 digits)	Hose	page
IH110013	 TBE	B11
IH301140	 RADIOR 10	B4
IH301165	 JUMBO N/L	I9
	 DRINKPRESS WB/L 10	H4
IH303151	 AIRBRAKE DIN 74310	B8
IH303512	 PYTHON NV/L 20	I7
	 PYTHON NY/L 30	I8
IH304127	 AUTOGENE EN ISO 3821 NR/L - NB/L 20	C4
IH304128	 AUTOGENE EN ISO 3821 NR/L - NB/L 20	C4
IH304129	 AUTOGENE EN ISO 3821 NR/L - NB/L 20	C4
IH304132	 AUTOGENE EN ISO 3821 NR/L - NB/L 20	C4
IH304134	 PROPANPRESS EN ISO 3821 NA/L 20	C5
IH305010	 CARBOPRESS N/L 10	A4
IH305020	 CARBOPRESS N/L 10	A4
IH305110	 CARBOPRESS N/L 10	A4
IH305120	 CARBOPRESS N/L 10	A4
IH305150	 CARBOBLUE N/L 20	B12
IH308313	 RADIOR K 1003	E6
IH308320	 OILPRESS N/L 20	I13
IH308361	 RADIOR DIN 6 G7	B6
IH308710	 TBSE	B10
395	 SERIES 395 SAE J 30R7	B9
IH350332	 VINITRESS	H9
IH350400	 APERFRUT 20 - 40 - 80	I13
IH350401	 APERFRUT 20 - 40 - 80	I13
IH350402	 APERFRUT 20 - 40 - 80	I13
IH355600	 ASPIREX	G7
IH355601	 ASPIREX	G7
IH355602	 ASPIREX	G7
IH355620	 ASPIREX	G7
IH355621	 ASPIREX	G7
IH356410	 APERSPIR	H10
IH356411	 APERSPIR	H10
IH362030	 IDRO 10	D4
IH362031	 IDRO 10	D4
IH362110	 BEVERA 10	D5
IH362140	 BEVERA 10	D5
IH362423	 GAMBRINUS UPE SM EN12115	H5

Partnumber (IH+6 digits)	Hose	page
IH362424	 GAMBRINUS BLUE 10	H6
	 GAMBRINUS BLUE SM 10	H7
IH362425	 GAMBRINUS RED SM 10	H8
IH363421	 MINIERA 20 MSHA	I10
IH363512	 PYTHON NV/L 20	I7
	 PYTHON NY/L 30	I8
IH365223	 CARBOCORD EN 12115	A6
IH365300	 CARBURITE 10	A5
	 CARBURITE 10	A5
IH365302	 CHEMIOEL EN 12115	A7
IH365304	 CERVINO EN 12115	A8
IH365310	 CARBURITE 10	A5
IH368000	 THERMOPRESS 10	E7
IH368017	 VIGOR 2 EN ISO 6134 TYPE 2/A	E8
	 POLIAX D EN 12115	F4
IH368101	 POLIAX D SM EN 12115	F5
	 POLIAX F EN 12115	F8
	 POLIAX PHARMA	F9
IH368115	 POLIAX UPE CON SM EN 12115	F6
	 POLIAX UPE CON SM EN 12115 OND	F7
IH368202	 LIBECCIO EN ISO 3861	G4
IH368203	 LIBECCIO EN ISO 3861	G4
IH368290	 CERGOM	G6
	 RADIOR 3 (COIL)	E4
IH368300	 RADIOR 3 (CUT LENGTH)	E5
IH368301	 RADIOR 3 (COIL)	E4
	 RADIOR 3 (COIL)	E4
IH368310	 RADIOR 3 (CUT LENGTH)	E5
	 RADIOR 3 (CUT LENGTH)	E5
IH368361	 RADIOR DIN 6	B6
389	 SUPER-FLEX® FL-7	B14
397	 SUPER-FLEX® FL	B15
6722	 SERIES 6722	B7
IH7092	 GST II RED 15	I5
	 GST II BLACK 15	I4
IH7093	 GST II BLACK 20	I6
	 WAVEMASTER™	B13
7165	 WAVEMASTER™	B13
IH7219	 E-Z FORM™ MP	I11
IH7395	 E-Z FORM™ GS	B5
7399	 E-Z FORM™ HT	A9

# Service – Helpdesk

An expert team of sales and customer service specialists are at your disposal, assuring proficient support and appropriate problem solving resources. Parker provides personal sales and technical support through local branch sales representatives as well as regional industrial hose sales specialists, product sales managers and engineers. We care about your business and seek to develop a close relationship with you.



# PARKER HANNIFIN – THE GLOBAL LEADER AND YOUR PARTNER

Parker Hannifin is the world's leading diversified manufacturer of motion and control technologies and systems, providing precision-engineered solutions for a wide variety of mobile, industrial and aerospace markets. Our products are vital to virtually everything that moves or requires control, including the manufacture and processing of raw materials, durable goods, infrastructure development and all forms of transport.

Our engineering expertise spans the core motion and control technologies – electromechanical, hydraulic and pneumatic – as well as a full complement of fluid control systems; software and electronic controls; filtration systems; and refrigeration, instrumentation and sealing technologies.

## Dry Technology

The leader in “dry technology” for the fluid power industry, Parker's Fluid Connectors Group is your single source for high-quality tube fittings, hose and hose fittings, thermoplastic tubing, brass fittings and valves, quick disconnect couplings and assembly tools.

## Markets

The Fluid Connectors Group serves customers in a broad range of markets, including Aerial Lift, Agriculture, Bulk Chemical Handling, Construction Machinery, Food & Beverage, Fuel & Gas Delivery, Industrial Machinery, Medical, Mining, Mobile, Oil & Gas and Transportation.

## Customer Services

Products are available for shipment 24 hours a day, supported by 50 manufacturing facilities throughout the world and a global distribution network. Our commitment to you is impeccable customer service. To meet your specific requirements, we offer a broad range of programs designed to reduce your overall operating costs, streamline manufacturing, improve productivity, manage inventory, enhance delivery and address safety and environmental issues. For value-added services that generate value-added solutions, team up with Parker!

# PARKER HANNIFIN – OPPORTUNITY THROUGH INNOVATION IN THE WORLD’S MOST DEMANDING MARKETS



## Worldwide availability

With more than 50 000 employees serving our valued customers in almost 50 countries, Parker is literally everywhere you need us to be. By working with us, you have access to an integrated network of 320 manufacturing plants, as well as an unrivalled global distribution network.

## Flexibility

As the world’s motion control expert, Parker offers you a complete range of proven, off-the-shelf products. These products deliver exceptional quality and durability, reducing costs and advancing performance.

## Innovation

It’s what drives us. Our mandate for continuous improvement leads us to partner with our customers to create solutions that are smaller, lighter, sustainable, more energy efficient, and highly reliable.

# Polymer Hose Division Europe

Performing solutions for every market and application wherever they are

Parker industrial hose products are the preferred choice across diverse applications, industries and markets. Whether the need is for durable rubber, lightweight and flexible composite, abrasion resistant PVC or extreme temperature silicone hose, Parker has the right hose for your job. We offer a wide variety of hose construction options, materials and performance criteria. Parker hoses are designed, built and supplied globally for long-lasting performance and superior value, and have earned a reputation for excellence in agriculture, construction, petrochemical, transportation and many other markets.

We supply a variety of hoses suitable for multiple media: standard hoses for traditional service as well as heavy duty hoses that provide superior resistance to abrasion, oils,

chemicals, heat, flame and cold. We have the ability and expertise to safely handle either hazardous media in hars environment and valuable and delicate media in protected environment.

From design, development and production to stocked inventory and shipment; we apply our know how and passion to provide our customers with solid and efficacious solutions.



## Our History of Experience

With our history of success and reputation as a world-class manufacturer of flexible rubber hose, we continue to pursue and develop technologies offering the best solution for every application. Recent activities includes: Pelican hose assembly for bunkering application in ports and docks, introduction of innovative products such as ultra-flexible E-Z Form hose, development of the breakthrough technology

such as extremely abrasion resistant CERGOM material handling hose, and special application hoses Carboblue. The latter hoses are environmentally friendly, providing the required high grade of cleanliness for the SRC technology reducing NOx emission. Our success stories include a number of global OEMs and distributors across many diverse industries. We contribute to short-and long-

term customer profitability by maximizing value through premier product quality and service.

# Capabilities

Our manufacturing process is supported by a highly qualified and experienced engineering staff and efficient production equipment. Deployment of these resources ensures precision control of the manufacturing process and materials, as well as the ability to create new design idea and implement solution. Now we have introduced into our range new materials such as silicone and PTFE to further meet customers' expectations and be more active in the industrial and chemical market segments.

Production line	ID min (mm)	ID max (mm)
Long Length	3	38
Mandrel Made	13	200
PVC	6	150
Thermoplastic	13	75
Silicone	13	51

# Quality

Parker is a company which operates in compliance with the quality system laid down by the UNI EN ISO 9001 and 14001 standard, certified by Bureau Veritas.

More and more Parker industrial hoses are certified by the main international certification bodies.



# Ecology



Caring for and ensuring the sustainability of the planet is our intention; we therefore develop and improve hoses for alternative fuels like gas, natural oils, ester oils etc. for environmentally-friendly technologies such as the new SCR one.

Parker developed nitrosamine-free compounds to improve the quality of life and of the environment.

We are doing more for our customers than ever before. Globally, we have localized service to provide fast, hassle-free responses and on-site support. We're staying close to our customers and integrating systems to help them become more profitable. We are committed to delivering our highly engineered products on-time, on-promise.

# Compounds

Our R&D team invests significant resources in the development of new and improved rubber compounds. The recipes are formulated according to the final

application of the hose, guaranteeing the utmost performance of the inner tube and cover. An efficient technical

center makes it possible to test and study

the properties and behavior of different ingredients in order to identify and solve possible critical problems. All aspects of compounds development and production – from design to testing to manufacturing – are constantly in compliance with main relevant international standards. Modern testing equipment allows us to check the product during any stage of the process.

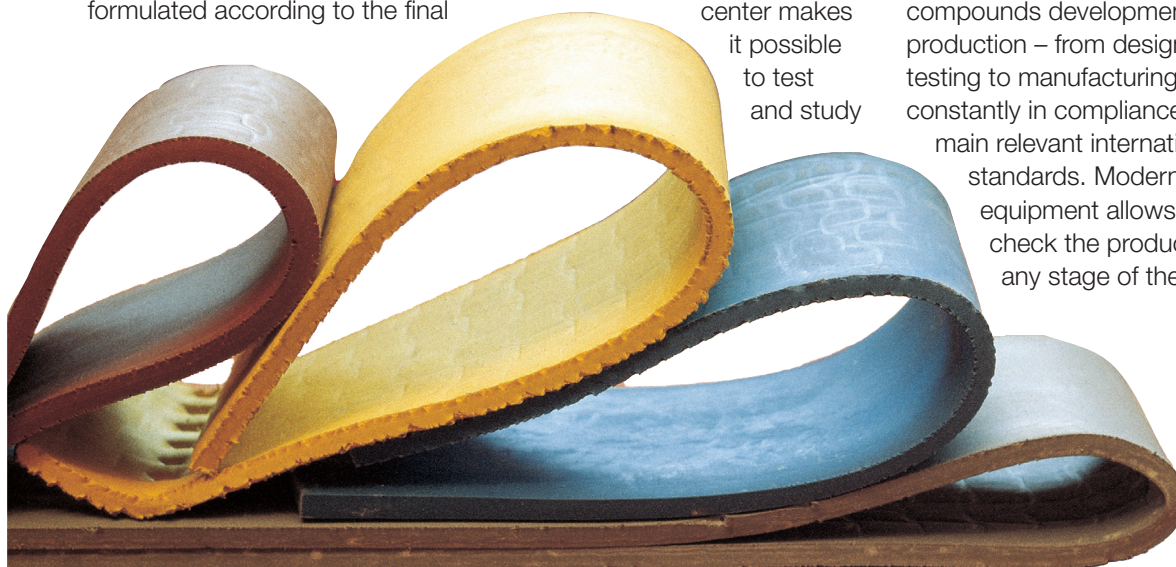

## Oil & Fuel Hose Pelican EN 1765 type S15

Pelican Hose is specially designed for bunkering operations. It is the activity for the loading, discharging and transferring of fuels between a bunker barge, a marine terminal or a marine facility from/ to a receiving ship. Bunkering operations needs to be performed diligently, safely with all necessary measures in place to prevent fuel spillage into the waters of the Port or onto the quayside. It is thus fundamental to have solid and reliable components aligned with the international industry standards. Pelican is recommended in

combination with Parker large bore crimped fittings range specifically designed for its structure and sold in customized length assemblies. Please contact our Customer Service Helpdesk in your local Parker location.

Supplied and tested with end crimped fittings enables a significant time reduction compared to traditional solution with vulcanized couplings optimizing the operability of end user. Parker Pelican hose assemblies are available conductive or discontinuous based on the individual application.

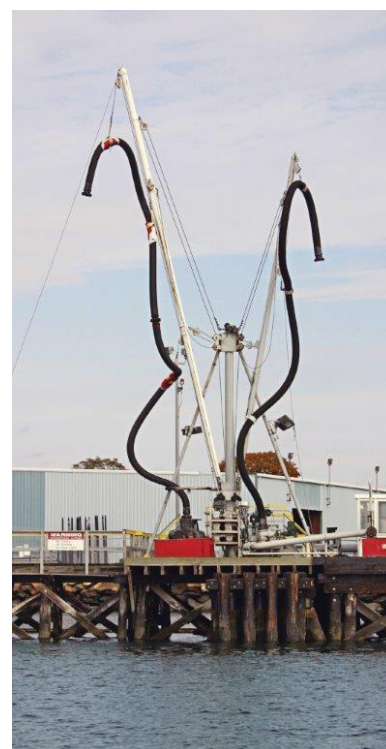

# Material Handling Transfer Hose – CERGOM

CERGOM is manufactured and patented based on a unique hose technology for pneumatic delivery and vacuum conveying systems of abrasive materials.

The hose is constructed in a combination of a new tube material with ceramic hexagonal plates. With the added benefit of the ultra high abrasion resistance, the hose has an increased service life in comparison to elastomer hoses qualities and rigid tubes and therefore the maintenance cost and machine shut downs will be reduced to a minimum. Together with the respective fitting range (swivel flanges) CERGOM is ideal for tough environments such

as steelworks, thermoelectric power plants, cement works, mining industry etc. CERGOM hose assemblies are very flexible in use with different working conditions and easier to handle than rigid elbows. Based on its construction, CERGOM hose

assemblies minimize significantly the vibration and noise during operation solving the toughest challenges for abrasive material handling.



## Global Hose

Same hose, same performance, same features, same availability everywhere

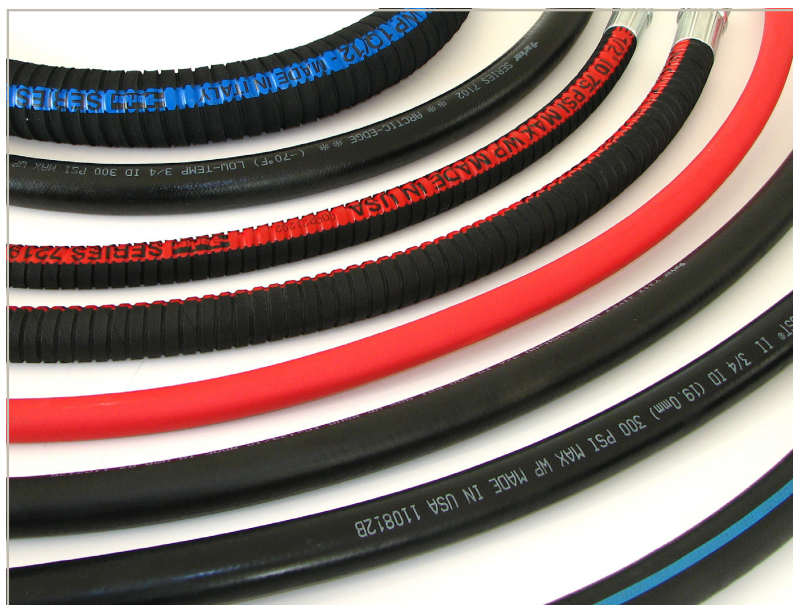

Our Global Hose Program consists of a worldwide network of Parker manufacturing facilities and distribution centers that assure consistent Parker quality while providing the flexibility to satisfy peaks of customer demand. The synergy among Industrial hose divisions around the world is one of our primary strength and an value-added support for our customers. Parker global hoses are suitable for OEMs and MRO channels, for diverse application across multiple industries and markets.

# Silicone Hose

Silicone rubber hose is the ultimate choice for those extreme-temperature application.

Silicone has a number of chemical and mechanical and offers benefits for designers and users such as: improved performance over the long haul; flexibility while retaining their shape for installation in tight envelopes or around obstructions; low permeation to reduce or eliminate emissions, odors. Last but not least, it can be truly sterilized to ensure purity of products being manufactured or processed. We offer solution either for cooling in industrial or transportation application (series 6722) and in the food, pharmaceutical and chemical industry (series Poliax Pharma).



For more information about Silicone Hose please refer to pages B7 & F9

# GAMBRINUS range

Rubber and PVC hose range specifically designed for food & beverage industry to efficiently and safely convey all foodstuff while preserving products features and consumer health.



For more information about the new GAMBRINUS range please refer to pages H5 - H8

The program includes specific alimentary hoses to withstand and preserve different typologies of foodstuff during the collecting, transport and processing phases. Produced on dedicated lines using stainless steel mandrels, our compounds are resistant to cleaning and sterilization to guarantee utmost hygienic standard. Each GAMBRINUS line is designed to fit specific products features. The appropriate manufacturing and performance standards are certified by

compliance with main European and International norms and specs such as EC 1935, BfR XXI, FDA. We also offer Stainless Steel Fittings capabilities – with permanently crimping ferrule or safety/bolt clamps – providing solutions to the most demanding applications in process plants. Our offering is supplemented with PVC hoses that offer an alternative to rubber where lighter weight is preferred.

## E-Z Form Hose

Kink-free E-Z Form™ Hose  
Eliminates the Need for Pre-formed Hose



E-Z Form hose provides extreme flexibility for easy and quick installation of coolant, water and oil suction/return lines on mobile and industrial equipment. Available in multiple incremental sizes, E-Z Form hose reduces installation time, eliminates the need for costly made-to-order pre-formed hose and provides rapid delivery from stock without requiring dedicated inventory.

The offer has been extended to a High Temperature version, designed to resist cracking and deterioration from the extreme heat generated by engine compartments of buses, cranes, trucks and mobile/heavy-duty off-road equipment. It may also be used in non-SAE power steering return line applications.

## Barrier Hose

Fuel, Vapor and Coolant/Heater Hoses

Parker offers a package of durable, flexible and lightweight hoses to handle virtually every engine-related requirement, including fuel supply, vapor emission and cooling. These can be used in multiple market segments such as agriculture, off-roads, marine and transportation. They are designed to comply with the main international standards (ISO, SAE) and offer a superior low permeability rate for a higher protection of components and users. Compatible with biodiesel, diesel, ethanol and gasoline.



# POLIAX range

Hoses manufactured with state-of-the-art compounds according to European standards to transfer chemicals, corrosive products and additives in mobile or fixed installations.

Extreme chemical transfer applications do not scare us; on the contrary it is part of our mission and a commitment. Our PoliAx product line inhibits the contamination of the environment and guarantees the integrity of the media conveyed. The hose meets or exceeds EN 12115 specifications. We have multiple construction typologies to suits as many needs as possible and the range has been extended to new materials silicone and PTFE to withstand higher temperatures and aggressive fluid

concentration. The corrugated version offers additional flexibility and it is easy to handle in case of routing constraints or manual operations. Due to many different media combinations of acids, solvents, alkalis - and aninfinite variety of possible combinations - we recommend to utilize the STAMP approach and always consult our chemical compatibility chart to select the most appropriate hose. If there are any doubts or question, contact a Parker engineer.

**For more information about the POLIAX range please refer to chapter F (Acid & Chemicals)**



# Industrial Hose Fittings

Your industrial application requires quality fittings that meet regulatory standards and outperform your expectations. Parker is up for the challenge with a variety of fittings with different end-configurations and geometry to meet all of your application needs.

We have tested and approved all offered fitting series for your application to enhance reliability and performance.

You can rely on Parker fitting series one-piece 48 and 56 series, two-piece 47 series with shell 10064 and IF series for large bore hoses.







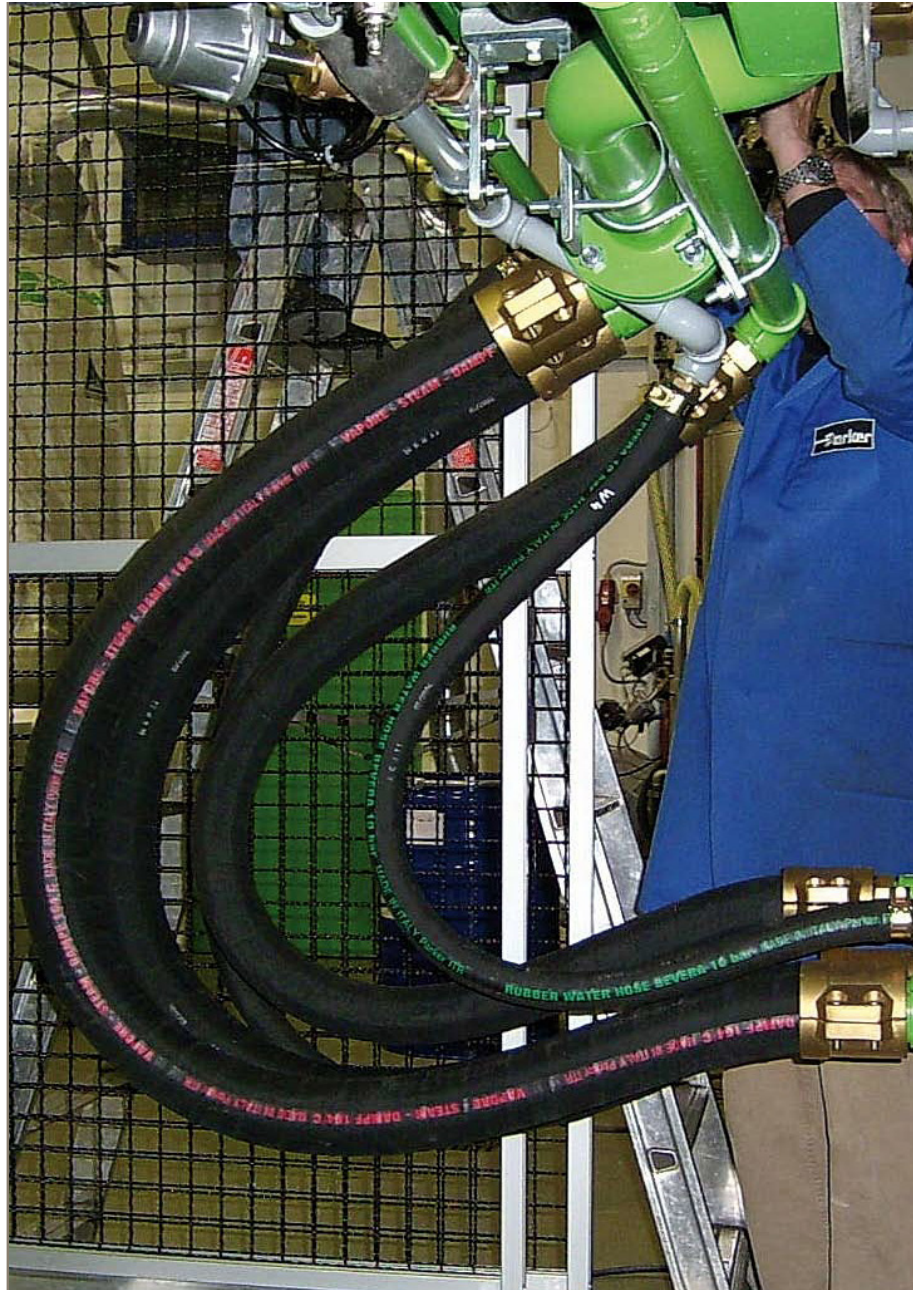
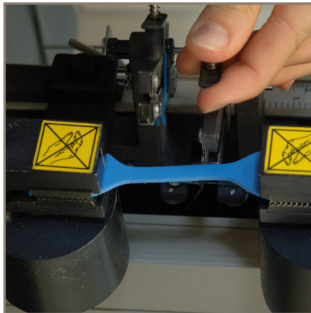

# Industrial Hoses

Technical Handbook



ENGINEERING YOUR SUCCESS.



# Technical Handbook

<b>Technical Handbook</b>	TH3
<b>Hose Selection Matrix</b>	TH4
<b>Rubber Hose Construction</b>	TH6
<b>PVC Hose Construction</b>	TH7
<b>Hose Part Number Description</b>	TH8
<b>Conversion Chart</b>	TH9
<b>Before you spec it, STAMP it.</b>	TH10 – TH11
<b>Standards</b>	TH12
<b>Guideline to Use and Cleaning of Food and Pharma Hose</b>	TH13
<b>Oil and Fuel Compatibility</b>	TH14
<b>Conductive Value Table</b>	TH15
<b>Properties of Basic Rubber Compounds</b>	TH16
<b>Chemical Resistance Table</b>	TH17 – TH32
<b>Chemical Resistance Guide for Silicone Hose</b>	TH33
<b>Rubber Hose Dimensional Tolerances</b> – According to norms	TH34
<b>PVC Hose Dimensional Tolerances</b>	TH34
<b>Parker Safety Guide</b>	TH35 – TH40
<b>Critical Applications</b>	TH39 – TH42

# Technical Handbook

## Hose Selection Matrix

Hose	ID Range (mm)	Temp. Range (°C)	Application	Tube	Reinforcement	Cover	WP (bar)	De-sign factor	Suc-tion	Industry standard	Page
<b>Oil &amp; Fuel</b>											
CARBOPRESS M/L 10	5 - 25	-25 / +80	Fuel, oil, petrol aromatics < 50 %	NBR	textile	NBR/EPDM	10	3			<?>
CARBURITE 10	19 - 150	-30 / +80	Fuel, oil, petrol aromatics < 50 %	NBR	textile	NBR/SBR	10	3	yes		<?>
CARBOCORD EN 12115	19 - 63.5	-25 / +80	Fuel, oil, petrol aromatics < 50 %	NBR	textile + copper wires	NBR/SBR	16	4		EN 12115	<?>
CHEMIOEL EN 12115	19 - 100	-25 / +80	Fuel, oil, petrol aromatics < 50 %	NBR	textile + copper wires	NBR/SBR	16	4	yes	EN 12115	<?>
CERVINO EN 12115	50 - 63.5	-40 / +80	Fuel, oil, petrol aromatics < 50 %	NBR	textile + copper wires	NBR/SBR	16	4	yes	EN 12115	<?>
E-Z FORM™ HT	12.7 - 25.4	-40 / +150	petroleum-based oil	CPE	textile	NBR	10	4	yes		A9
<b>Automotive &amp; Boat</b>											
RADIOR 10	7 - 15	-30 / +100	cooling line system	EPDM	textile	EPDM	10	3			B4
E-Z FORM™ GS	12.7 - 102	-45 / +125	high flexible hose for coolant line system	EPDM	textile	EPDM	5	4	yes	SAE J 20R2 - D1	B5
RADIOR DIN 6	10 - 50	-40 / +125	cooling line system	EPDM	textile	EPDM	6	3			B6
Series 6722	6 - 25	-54 / +177	Heater and cooling line system	SILICONE	textile	SILICONE	5.7	3		SAE J20R3 Class A	B7
AIRBRAKE DIN 74310	9 - 13	-40 / +70	breaking system	EPDM	textile	EPDM	10	4		DIN 74310	B8
Series 395 SAE J 30R7	4.8 - 12.7	-40 / +125	car & motorbike fuel system	NBR	textile	CR	2,4/5,2	5		SAE 30 R7	B9
TBSE	4 - 10	-30 / +100	car & motorbike fuel system	NBR	textile	NBR/EPDM	10	3			B10
TBE	3 - 7.5	-20 / +90	car & motorbike fuel system	NBR	textile		10	3			B11
CARBOBLUE M/L 20	6 - 25	-40 / +100	nox reducing system	EPDM	textile	EPDM	20	3			B12
WAVEMASTER™	6.3 - 19	-29 / +100	marine barrier fuel hose	NYLON	textile	NBR/PVC	7	4	light	Refer to the page	B13
SUPER-FLEX® FL-7	4.7 - 19.1	-40 / +125	low permeation fuel hose	NBR/THV	textile	CPE	6.9	5	light	SAE J30R7/J30R14T2	B15
SUPER-FLEX® FL	4.7 - 15.9	-30 / +125	low permeation fuel hose	NBR/barrier	textile	CPE	6.9	5	light	AEJ30R7/J30R14T2	B16
<b>Gas</b>											
AUTOGENE EN ISO 3821 NPL - NB/L 20	6.3 - 10	-25 / +80	welding process	EPDM/SBR	textile	EPDM	20	3		EN ISO 3821	<?>
PROPANIPRESS EN ISO 3821 NAL/L 20	6.3 - 10	-30 / +70	propan gas delivery	NBR/NR	textile	EPDM	20	3		EN ISO 3821	<?>
CARBO G NY/L 10	8 - 13	-20 / +90	household appliances	NBR	textile	EPDM	10	3		UNI OIG 7140	<?>
IDRO 10	25 - 40	-30 / +80	water, non aggressive liquids	SBR	textile	SBR	10	3			<?>
BEVERA 10	19 - 125	-30 / +80	water, non aggressive liquids	SBR	textile	SBR	10	3	yes		<?>
<b>Water</b>											
RADIOR 3	10 - 100	-40 / +100	cooling line system	EPDM	textile	EPDM	3	3			<?>
RADIOR K 1003	12 - 50	-40 / +100	cooling line system	NBR	textile	CR	5	3			<?>
THERMOPRESS 10	12 - 40	-40 / +100	cooling line and hot water	EPDM	textile	EPDM	10	4			<?>
VIGOR 2 EN ISO 6134 Type 2/A	13 - 51	-40 / +210	steam industrial application	EPDM	textile	EPDM	18	10		EN ISO 6134 Type 2/A	<?>
<b>Hot Water &amp; Steam</b>											
POLIAX D EN 12115	19 - 100	-35 / +100	chemical resistance table	EPDM	textile + copper wires	EPDM	16	4		EN 12115	<?>
POLIAX D SM EN 12115	19 - 100	-35 / +100	chemical resistance table	EPDM	textile + copper wires	EPDM	16	4	yes	EN 12115	<?>
POLIAX UPE CON SM EN 12115	19 - 100	-20 / +100	chemical resistance table	UHMWPE	textile + copper wires	EPDM	16	4	yes	EN 12115	<?>
POLIAX UPE CON SM EN 12115 OND	19 - 75	-20 / +100	chemical resistance table	UHMWPE	textile + copper wires	EPDM	16	4	yes	EN 12115	<?>
POLIAX F EN 12115	13 - 75	-40 / +150	chemical resistance table	PTFE	textile + copper wires	EPDM	16	4	yes	EN 12115	<?>
POLIAX PHARMA	13 - 51	-60 / +200	chemical resistance table	SILICONE	textile + copper wires	SILICONE	6/15	3	yes		<?>

• • ISO 7840, ABYC, CARB, CE, EPA, NIMMA, SAE J1527 A1-15, USCG A1 • •

Hose	ID Range (mm)	Temp. Range (°C)	Application	Tube	Reinforcement	Cover	WP (bar)	De-sign factor	Suc-tion	Industry standard	Page
LIBECCIO EN ISO 3861	19 - 80	-30 / +70	wet and dry sand and cement	BR/NR	textile	SBR/NBR	10	4		EN ISO 3861	<?>
BETON 80	51 - 125	-40 / +70	high pressure concrete pumping	NR/SBR	steel wire	NR/SBR	80	2.5			<?>
CERGOM	25 - 200	-30 / +70	high abrasive materials	CERAMIC	textile + copper wires	SBR/NBR	6	3	yes		<?>
ASPIREX	20 - 100	-15 / +60	suction equipment	PVC	PVC wire	PVC	-	-	yes		<?>
DRINKPRESS WB/L 10	10 - 25	-20 / +100	food & beverage, wash-down	NBR	textile	NBR/PVC	10	4		FDA - EC	<?>
GAMBRINIUS UPE SM EN12115	19 - 100	-20 / +100	food & beverage	UHMWPE	textile + copper wires	EPDM	16	4	yes	**EN 12115 - FDA - DM	<?>
GAMBRINIUS BLUE 10	19 - 80	-30 / +80	fatty food & beverage	NBR	textile	NBR/PVC	10	3		* BfR - DM - FDA - EC	<?>
GAMBRINIUS BLUE SM 10	19 - 102	-30 / +80	fatty food & beverage	NBR	textile	NBR/PVC	10	3	yes	* BfR - DM - FDA - EC	<?>
GAMBRINIUS RED SM 10	19 - 102	-40 / +120	wine and soft drinks food & beverage	EPDM	textile	EPDM	10	3	yes	* BfR - DM - FDA - EC	<?>
VINITRESS	6 - 50	-20 / +60	food & beverage	PVC	textile	PVC	20	3		EC 90/128 CLASS A-B-C	<?>
APERSPIR	12 - 150	-10 / +60	food & beverage	PVC	steel wire	PVC	15	3	yes	EC 90/128 CLASS A-B-C	<?>
GST II Black 15	5 - 38	-40 / +100	compressed air, non aggressive liquids	EPDM	textile	EPDM	15	4			<?>
GST II Red 15	6.5 - 38	-40 / +100	compressed air, non aggressive liquids	EPDM	textile	EPDM	15	4			<?>
GST II Black 20	6.5 - 25	-40 / +100	compressed air, non aggressive liquids	EPDM	textile	EPDM	20	4			<?>
PYTHON N/L 20	10 - 50	-40 / +100	multipurpose	EPDM	textile	EPDM	20	3			<?>
PYTHON N/L 30	6 - 100	-40 / +120	multipurpose	EPDM	textile	EPDM	30	3			<?>
JUMBO N/L	13 - 25	-40 / +120	multipurpose	EPDM	textile	EPDM	20	3			<?>
MIMIERA 20 MSHA	19 - 50	-30 / +80	compressed air, non aggressive liquids	SBR/NBR	textile	CR	20	3		MSHA	<?>
E-Z FORM™ MP	12.7 - 75	-34 / +120	high flexible hose for multipurpose	NBR	textile	CR/NBR	5	4	yes		<?>
OILPRESS N/L 20	6 - 25	-35 / +100	multipurpose	NBR	textile	NBR/PVC	20	3			<?>
APERFRUT 20	13 - 19	-15 / +60	agricultural spray	PVC	textile	PVC	20	4			<?>
APERFRUT 40	10	-15 / +60	agricultural spray	PVC	textile	PVC	40	3			<?>
APERFRUT 80	8 - 13	-15 / +60	agricultural spray	PVC	textile	PVC	80	2.5			<?>

# Rubber Hose Construction



## Tube

It is the innermost rubber or plastic element of the hose. Must be resistant to the materials it is intended to convey. The characteristics of the rubber or plastic compound and the thickness of the tube depend on the service in which the hose will be used.

## Reinforcement

Can be textile, plastic or metal, alone or in combination, built into the body of the hose to withstand internal pressures, external forces or combination of both.

## Cover

It is the outer element and can be made of rubber, plastic or textile materials. The function of the cover is to protect the hose from damage and environment.

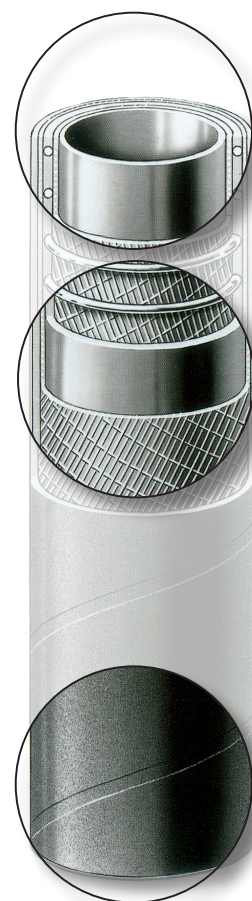

## Long Length (LL)

### Production method:

Seamless extruded hoses without or on flexible mandrel and eventually white lead vulcanization with synthetic textile yarn reinforcement for standard production up to 100 m and internal diameter up to I.D. 35 mm.

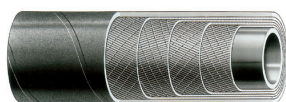

## Mandrel Made (MM)

### Production method:

Hose produced on a rigid mandrel with a reinforcement of textile fabrics or steel braids, with or without steel wire helix, for standard production length up to 40 m and internal diameter range from I.D. 19 mm to I.D. 200 mm.

# PVC Hose Construction

Flexible hose having a rigid PVC spiral or a steel wire reinforcement spiral embedded in a PVC wall.

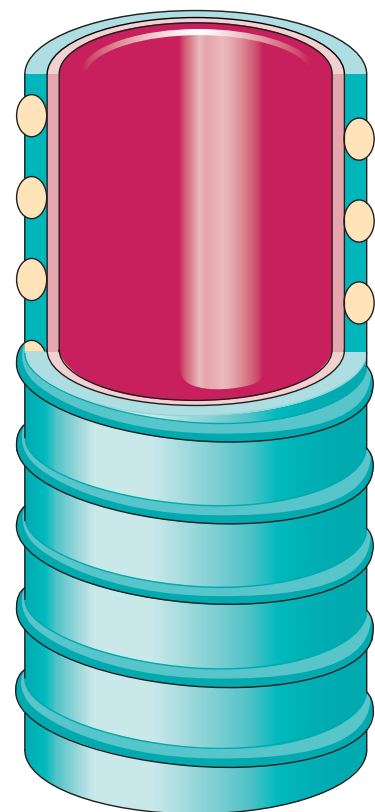
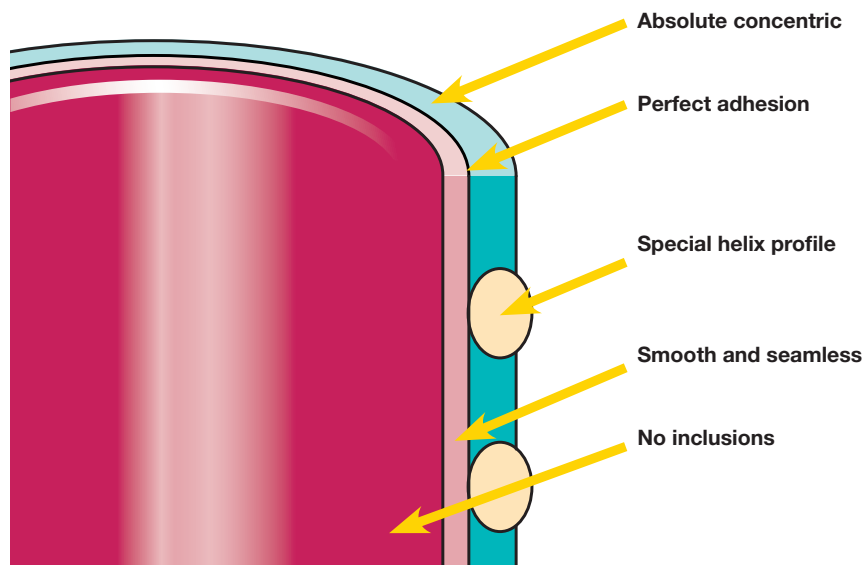

## Hose Part Number Description

IH35.... --> PVC Hose

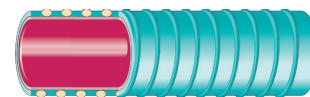

IH30.... --> Long Length Rubber Hose



IH36.... --> Mandrel made Rubber Hose



IH42.... --> Mandrel made Rubber Hose



IH7.... --> Global Hose Series

### Example

IH35562019/50 --> PVC Hose

IH35562019/50 --> PVC Hose, length 50 m

IH35562019/0 --> PVC Hose, length: variable

Hose to be ordered in coils.



# Conversion Chart

	Unit	Base Unit	Conversion Unit	Factor
Length	1 inch	in	mm	25.4
	1 millimetre	mm	in	0.03934
	1 foot	ft	m	0.3048
	1 metre	m	ft	3.28084
Area	1 square-inch	sq in	cm <sup>2</sup>	6.4516
	1 square-centimetre	cm <sup>2</sup>	sq in	0.1550
	1 gallon (UK)	gal	l	4.54596
Volume	1 litre	l	gal (UK)	0.219976
	1 gallon (US)	gal	l	3.78533
	1 litre	l	gal (US)	0.264177
Weight	1 pound	lb	kg	0.453592
	1 kilogramme	kg	lb	2.204622
Torque	1 pound foot	lb • ft	kg • m	1.488164
	1 newton metre	kg • m	lb • ft	0.671969
	1 pound per square inch	psi	bar	0.06895
	1 bar	bar	psi	14.5035
	1 pound per square inch	psi	MPa	0.006895
Pressure	1 mega pascal	MPa	psi	145.035
	1 kilo pascal	kPa	bar	0.01
	1 bar	bar	kPa	100
	1 mega pascal	MPa	bar	10
	1 bar	bar	MPa	0.1
Velocity	1 foot per second	ft / s	m / s	0.3048
	1 metre per second	m / s	ft / s	3.28084
	1 gallon per minute (UK)	gal / min.	l / min.	4.54596
Flow rate	1 litre per minute	l / min.	gal / min. (UK)	0.219976
	1 gallon per minute (US)	gal / min.	l / min.	3.78533
	1 litre per minute	l / min.	gal / min. (US)	0.264178
Temperature	Fahrenheit degree	°F	°C	5/9 • (°F-32)
	Celsius degree	°C	°F	°C • (9 / 5) +32

(UK) Unit of United Kingdom  
(US) Unit of USA

# Before you spec it, STAMP it.

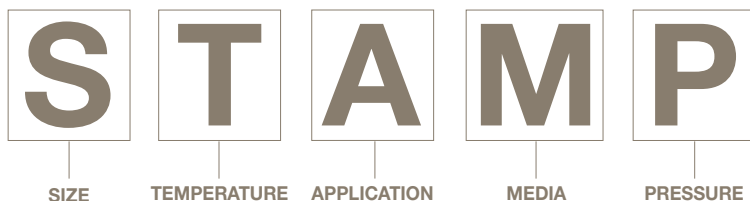

## SIZE

The hose Internal and External Diameter must be sized accurately to obtain the proper values to couple the hose with reusable or permanent fittings. The measuring system of the inside and outside diameter of the hose is universally regulated by ISO 4671 while the hose tolerances are listed in the ISO 1307 if not superseded by particular and specific other norms (i.e. EN 12115).

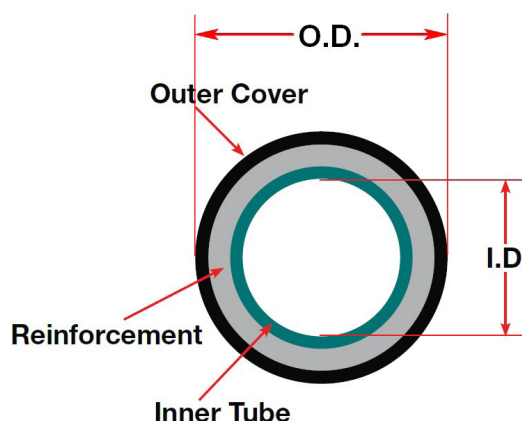

## TEMPERATURE

When specifying hose, there are two temperatures you need to identify. One is the **ambient temperature** which is the temperature that exists outside the hose in the application where it is being used; the other is the **media temperature** which is the temperature of the media conveyed through the hose. Very high or low ambient temperatures can have adverse effects on the hose cover and reinforcement materials, resulting in reduced service life. Media temperatures can have a much greater impact on hose life. For example, rubber loses flexibility if operated at high temperatures for extended periods.

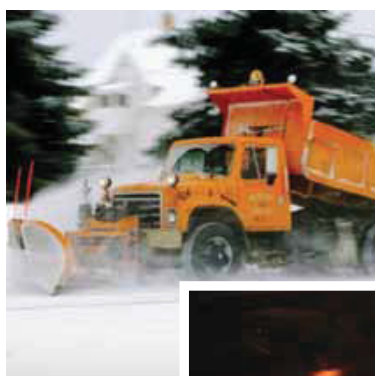



## APPLICATION

Before selecting a hose, it is important to consider how the hose will be used. Answering the following questions may help:

- Which is the media conveyed?
- What type of equipments are involved?
- Is it a static or dynamic application?
- Are there any routing constrains?
- Do you need particular cover features?
- Should the hose comply with any industry or government standards?
- Which are the electrical hose conductivity/resistance requirements?



Sometimes specific applications require hoses specific dimensions, features or performance characteristics. For example, applications where hoses will encounter rubbing or abrasive surfaces, would be best handled by our family of abrasion resistant hose. When application space is tight, bend radius is another important consideration. We offer hoses with increased flexibility and smaller outer diameters enabling faster, easier routing in small spaces, reducing both hose length and inventory requirements. Industry standards set specific requirements concerning construction type, size, tolerances, burst pressure, and media compatibility. You must select a hose that meets the legal requirements as well as the functional requirements of the application.

## MEDIA

What will the hose convey? Some applications require the use of specialized oils or chemicals. The hose you order must be compatible with the medium being conveyed. Compatibility must cover the inner tube, the cover, hose fittings, and o-rings as well. Use the Oil and Fuel and Chemical Resistance Chart you find in this section to select the correct components of the hose that will be compatible with your system's media.



## PRESSURE

Hose selection must be made so that the published maximum working pressure of the hose is equal to or greater than the maximum system pressure. Surge pressures or peak transient pressures in the system must be below the published maximum working pressure for the hose.

Each Parker hose has a pressure rating which can be found on the HOSE SELECTION MATRIX. Burst pressure ratings are not an indication that the product can be used above the published maximum working pressure. It is for this reason that the burst pressure ratings have been removed from the hose charts within the catalog. However the burst pressure is indicated by the design factor of each hose type.



# Standards

<b>ABYC</b> WAVEMASTER™	<b>EN 12115</b> CARBOCORD EN 12115 CERVINO EN 12115 CHEMIOEL EN 12115 GAMBRINUS UPE SM EN 12115 POLIAX D EN 12115 POLIAX D SM EN 12115 POLIAX F EN 12115 POLIAX UPE CON SM EN 12115 POLIAX UPE CON SM OND EN 12115	<b>NMMA</b> WAVEMASTER™
<b>BfR XXI cat. 2</b> GAMBRINUS BLUE 10 GAMBRINUS BLUE 10 SM GAMBRINUS RED 10 SM POLIAX PHARMA	<b>EN ISO 3821</b> AUTOGENE EN ISO 3821 NR/L - NB/L 20 PROPANPRESS EN ISO 3821 NA/L 20	<b>SAE J 30 R7</b> CARBOPRESS SAE J 30 R7 SUPER-FLEX® FL SUPER-FLEX® FL-7
<b>CARB</b> WAVEMASTER™	<b>EN ISO 3861</b> LIBECCIO EN ISO 3861	<b>SAE J 20 R2 - D1</b> E-Z FORM™ GS
<b>CE</b> WAVEMASTER™	<b>EN ISO 6134</b> VIGOR 2 EN ISO 6134 Type 2/A	<b>SAE J 20 R3 Class A</b> SERIES 6722
<b>DIN 73411</b> RADIOR DIN 6	<b>EN ISO 7840</b> WAVEMASTER™	<b>SAE J 30 R14T2</b> SUPER-FLEX® FL SUPER-FLEX® FL-7
<b>DIN 74310</b> AIRBRAKE DIN 74310	<b>EPA</b> WAVEMASTER™	<b>SAE J1527 A1-15</b> WAVEMASTER™
<b>DM 21/03</b> GAMBRINUS BLUE 10 GAMBRINUS BLUE 10 SM GAMBRINUS RED 10 SM GAMBRINUS UPE SM EN 12115 POLIAX PHARMA	<b>European Pharmacopoeia</b> POLIAX PHARMA	<b>USCG A1</b> WAVEMASTER™
<b>DM 220 26/04/93</b> GAMBRINUS UPE SM EN 12115	<b>MSHA</b> MINIERA 20 MSHA	<b>USP XXXII class - VI requirements</b> POLIAX PHARMA POLIAX F
<b>EC 1935:2004</b> GAMBRINUS BLUE 10 GAMBRINUS BLUE 10 SM GAMBRINUS RED 10 SM	<b>FDA</b> DRINKPRESS WB/L 10 GAMBRINUS BLUE 10 GAMBRINUS BLUE 10 SM GAMBRINUS RED 10 SM GAMBRINUS UPE SM EN 12115 POLIAX F POLIAX PHARMA	
<b>EU 10/2011</b> VINITRESS APERSPIR		

# Guidelines to the Use and Cleaning of Food and Pharma Rubber Hose

The hoses offered in our catalogue are manufactured in accordance with the best production practices, observing the international norms and specifications regulating this sector to guarantee safety, performance, quality and hygiene.

Transport, storage, handling, usage and media may contaminate the hose and affect its performance.

Therefore Parker recommends cleaning and sanitizing the hose prior to and after each use to maintain hose efficiency and prevent harmful contamination.

However our suggestions are superseded by specific local government regulations and industry standards.

## Cleaning and sanitizing steps:

- flush with hot drinking water
- Cleaning process with detergents/chemicals
- Rinse with drinking water at 20 °C for max 10 min
- Sterilization process
- Rinse with drinking water at 20 °C for max 10 min
- Check to determine that all residuals have been eliminated

The frequency depends on the type of food and liquid conveyed and environment condition.

The frequency and time of exposure to detergents/ disinfectants may compromise the service life of the hose. Thus we recommend regular inspection of the hose to evaluate its physical conditions.

Media	Compound	Concentration	Temperature
Hot Water	NBR, UPE, EPDM, SILICONE	-	Up to 90 °C
Steam	NBR	-	Up to 110 °C – max 10 min
	EPDM, UPE, PTFE	-	Up to 130 °C – max 30 min
	SILICONE	-	Up to 135 °C – max 18 min
Alkaline Solution (Caustic Soda)	NBR, SILICONE	2%	Up to 65 °C
		4%	Up to 25 °C
	EPDM, UPE, PTFE	2%	Up to 85 °C
		5%	Up to 25 °C
Nitric Acid	NBR, SILICONE	0,1%	Up to 65 °C
		2%	Up to 25 °C
	EPDM, UPE, PTFE	0,1%	Up to 85 °C
		3%	Up to 25 °C
Peracetic Acid	NBR, SILICONE	1%	Up to 25 °C
	EPDM, UPE, PTFE		Up to 40 °C

For other cleaning media and support pls contact Parker

# Oil and Fuel Compatibility

Hose series	Max Ambient temperature °C	Fuel types							
		Fuel	Diesel	LPG-CNG	B10	B20	B100	E10	E100
CARBOCORD EN 12115	100	G up to 70°	E up to 70°	⊕ up to 70°	G up to 70°	G up to 70°	⊕ up to 70°	G up to 70°	⊕ up to 70°
CARBOPRESS N/L	100	G up to 70°	E up to 70°	X	E up to 70°	E up to 70°	E up to 70°	G up to 70°	⊕ up to 70°
Series 395 SAE J 30 R7	125	E up to 70°	E up to 100°	G up to 70°	E up to 100°	E up to 70°	G up to 70°	E up to 70°	E up to 70°
CARBURITE 10	100	E up to 70°	E up to 70°	⊕ up to 70°	G up to 70°	G up to 70°	⊕ up to 70°	G up to 70°	⊕ up to 70°
CERVINO EN 12115	100	E up to 70°	E up to 70°	⊕ up to 70°	G up to 70°	G up to 70°	⊕ up to 70°	G up to 70°	G up to 70°
CHEMIOEL EN 12115	100	E up to 70°	E up to 70°	⊕ up to 70°	G up to 70°	G up to 70°	⊕ up to 70°	G up to 70°	G up to 70°
E-Z FORM™ HT	150	E up to 120°	E up to 120°	⊕ up to 120°	E up to 120°	E up to 120°	G up to 100°	G up to 70°	G up to 70°
E-Z FORM™ MP	121	E up to 100°	E up to 100°	⊕ up to 100°	E up to 100°	E up to 100°	⊕ up to 100°	G up to 70°	G up to 70°
OILPRESS N/L	120	G up to 70°	E up to 100°	G up to 70°	E up to 100°	E up to 70°	E up to 70°	G up to 70°	E up to 70°
SUPER-FLEX® FL	125	E up to 100°	E up to 100°	⊕ up to 100°	E up to 100°	E up to 100°	E up to 100°	E up to 100°	G up to 100°
SUPER-FLEX® FL-7	125	E up to 100°	E up to 100°	⊕ up to 100°	E up to 100°	E up to 100°	G up to 100°	E up to 100°	G up to 100°
TBE	90	E up to 70°	E up to 70°	⊕ up to 70°	G up to 70°	G up to 70°	X	E up to 70°	G up to 70°
TBSE	100	E up to 70°	E up to 70°	G up to 70°	G up to 70°	G up to 70°	X	E up to 70°	G up to 70°
WAVEMASTER™	100	E up to 70°	E up to 70°	⊕ up to 70°	E up to 70°	E up to 70°	E up to 70°	E up to 70°	G up to 70°

Fuel max 50 % Aromatic ( Aliphatic /Aromatic + MBTE)  
 Diesel Std mineral Diesel  
 LPG-CNG Liquefied petroleum gas or Compressed Natural gas  
 B10 Biodiesel 10 % in std diesel  
 B20 Biodiesel 20 % in std diesel  
 B100 Biodiesel 100 %  
 E10 Ethanol Alcohol 10 % in Fuel  
 E100 Ethanol Alcohol 100 %

The indicate temperature is related to the Media and not to the ambient

**E** = Excellent  
**G** = Good  
 ⊕ = Conditional  
**X** = Unsatisfactory

# Conductive Value Table

As for ISO 8031

$R < 10^6$	Conductive Compound
$10^3 < R < 10^8$	Antistatic Compound
$R > 10^8$	Insulating Compound

## Electrical Properties of Rubber Hose

### Electrical Conductivity

Industrial hoses generally fall into three categories: conductive, nonconductive, or somewhere in-between. Because of its unique properties, it is possible for rubber to be nonconductive at low voltage and conductive at high voltage. When using a hose in an application that has electrical resistance requirements (low electrical resistance for conductive applications or high electrical resistance for nonconductive applications), always select a hose that is specifically designed to meet the specific need. Since conductivity or no conductivity is not a consideration for many applications, electrical resistance ratings do not exist for many hoses.

### Conductive & Antistatic Hose

Static electricity is generated by the flow of material (even some liquids) through a hose. As the material flows, molecules collide and generate friction, which creates minute amounts of electrical charge (excess electrons). The charge accumulates potential energy at the delivery end of the hose (coupling/nozzle). The amount of charge increases with material volume and linear velocity, coarseness of the material, and length of the hose. If not properly grounded, the accumulated charge (potential energy) will seek its own ground. The charge will be attracted to external materials in proximity (such as a steel storage container); if not properly grounded, the electrons may arc (jump) to the external material, igniting volatile materials in the hose, or in proximity to the hose. Electrically conductive wires and conductive rubber components are used in hose to prevent static electricity build-up and discharge as a spark. It is essential that the user determine the need for static bonded hose based on (a) the intended use of the hose, (b) instructions from the company's safety division, (c) the insurer, and (d) the laws of the localities and states in which the hose will be used. Some types of hose include a helical or static wire(s). This wire can be used for electrical continuity provided that proper contact is made and maintained between it and the hose couplings.

### Nonconductive Hose

Nonconductive hose constructions are those that resist the flow of electrical current. In some specific applications, especially around high voltage electrical lines, it is imperative for safety that the hose be nonconductive. Unless the hose is designed particularly to be nonconductive and is so branded, do not conclude that it is nonconductive. Many black rubber compounds are inherently and inadvertently conductive. Nonconductive hose is usually made to a qualifying standard that requires it to be tested to verify the desired electrical properties. The hose is frequently (but not necessarily) non-black in colour and clearly branded to indicate it is designed for nonconductive applications.

#### WARNING!

Unless a hose is described as, or specifically and clearly branded to be conducting or nonconducting, assume that the electrical properties are uncontrolled.

# Properties of Basic Rubber Compounds

This table provides some information on the general properties of the most common rubber compounds. Most compounds used in the manufacture of rubber hose are made of different basic rubbers, each contributing to the physical properties of the finished product.

ASTM D 1418	Chemical Name	Properties
CR	<b>Chloroprene</b>	Excellent weathering and ozone resistance, flame retarding, abrasion resistance. Good resistance to compressed air and to oil.
CSM	<b>Chloro-sulfonyl-polyethylene</b>	Excellent resistance to ozone, weathering and acid, particularly of the coloured compounds. Resistant to petroleum based fluids.
EPDM	<b>Terpolymer of ethylene-propylene-diene</b>	Good resistance to heat, ageing and abrasion. Poor resistance to petroleum based fluids.
EPM	<b>Copolymers of ethylene and propylene</b>	Excellent resistance to heat, ageing, abrasion and ozone. Good resistance to many chemicals. Poor resistance to aromatics.
FKM	<b>Fluorine rubber</b>	Excellent resistance to a wide range of chemicals and to heat. Poor physical properties.
IIR	<b>Isobutene-isoprene</b>	Good resistance to chemicals, such as alcohols, ketones and esters.
NBR	<b>Acrylonitrile-butadiene</b>	Excellent oil resistance good aromatics and solvents resistance.
NR	<b>Natural rubber</b>	Good physical properties including abrasion and low temperature resistance. Poor resistance to petroleum based fluids.
SBR	<b>Styrene-butadiene</b>	Good physical properties with resistance to heat and abrasion. Poor resistance to petroleum based fluids.
NBR/PVC	<b>Acrylonitrile-butadiene-vynil-chloride</b>	Good resistance to oil and aromatics. Recommended as hose cover, when a good weathering, ozone and abrasion resistance is required.
UHMWPE	<b>Ultra high molecular weight polyethylene</b>	Excellent abrasion resistance and very low coefficient of friction. Excellent resistance to chemicals, oil and aromatic fuels. Biologically inert and suitable for foodstuffs delivery.
PTFE	<b>Polytetrafluoroethylene</b>	Excellent resistant against the majority of chemicals, also at high concentration. Superior resistance to heat. Very low friction. Great mechanical properties.
Silicone (VMQ)	<b>Polysiloxane</b>	Outstanding Heat and cold resistance. Resistance to oils, solvents and other chemicals. Electrical insulation.

## Chemical Resistance Table

# Chemical Resistance Table

The following table is essentially based upon the most updated technical data available, on information from raw material suppliers, as well as some International Standards, e.g. ISO TR 7620, EN 12115, and other publications.

Due to the big variety and amount of different chemical products, the given ratings are only partly based on our own tests. Consequently, the chart is given as a guidance only, and it cannot be assumed as a guarantee, expressed or implied, for the suitability of a product for a specific application. This is due to the widespread range of parameters which are not under our direct control like temperature (internal and external) pressure (constant or peaks) frequency of service and working environment.

For the same reasons, it is impossible to give scientifically based indications concerning service life of hoses, and to determine a generally valid replacement date. This can be verified for instance with periodical hydrostatic tests and a visual check. When in doubt please contact our technical service.

Ratings are based on room temperature.

Parker will cooperate by supplying sampling for tests, and carrying out tests with special chemical products.

**WARNING**

The service life of rubber hoses is not endless. Consequently the user must periodically check the suitability of a rubber hose for the intended application, particularly in the presence of dangerous or polluting chemical products or when using the hose at elevated pressures and/or temperatures. Continuous use at the highest allowed pressures and temperatures dramatically reduces the service life of a rubber hose.

After use hose must be emptied out and washed down.

Many chemical products can cause severe injuries to people or damage to property, or risks of environmental pollution if the hose leaks or bursts.

Trade Name	Description	ASTM Codes
Butyl	Isobutylene-Isoprene	IIR
CPE	Chlorinated Polyethylene	CM
EPDM	Ethylene-Propylene-Diene	EPDM
Hypalon	Chlorosulfonated Polyethylene	CSM
Hytrek	Thermoplastic Polyester	TPC-ET
Natural	Natural Rubber	NR
Neoprene	Polychloropren	CR
Nitrile	Acrylonitrile	NBR
Nylon	Nylon Polymer	-
SBR	Styrene-Butadiene	SBR
Teflon	Fluorocarbon Resin	PTFE
UHMWPE	Ultra-High Molecular Weight Polyethylene	-
Viton	Fluroelastomer	FKM
XLPE	Cross-Linked Polyethylene	XPE

\* compounds not in catalogue. Ask Parker for right solution

**KEY**

E = Excellent

G = Good

C = Conditional

X = Unsatisfactory

Chemical or Material Conveyed	Butyl	CPE	EPDM	CSM	TPC-ET	Natural	Neoprene	Nitrile	Nylon	SBR	TPV	PTFE	UHMWPE
1 UNDECANOL	E			E		E		E				E	
1,4-DIOXANE	G		G	X		X	X	X	E	X		E	
1-AMINO-2-PROPANOL	E			C		G		G				E	
1-AMINOBTANE	X		C	C		X	X	C		X		E	
1-AMINOPENTANE	G		X	G		G	X	C				E	
1-BROMO-2 METHYL PROPANE	X			X		X	X	X				E	
1-BROMO-3 METHYL BUTANE	X		X	X		X	X	X				E	
1-BROMOBUTANE	X			X		X		X				E	
1-CHLORO-2-METHYL PROPANE	X			X		X		X				E	
1-CHLORO-3-METHYL BUTANE	C		X	X		X	X	X	E			E	
1-DECANOL	C			E		C	X	E				E	
1-HENDACONAL		E											
2 (2AMINOETHYLAMINO) ETHANOL	E			G		G		G					
2 (2ETHOXYETHOXY) ETHANOL	E		G	G		C	C	G	E	G		E	
2 (2ETHOXYETHOXY) ETHYL ACETATE	G		X	G		X	X	C		X		E	
2,4-DI-SEC-PENTYLPHENOL		E											
2-AMINOETHANOL	E		G	G		G	G	G				E	
2-CHLORO-1-HYDROXY-BENZENE		C											
2-CHLOROPHENOL	G	G	X	C	X	X	X	X	X	X	X	E	
2-CHLOROPROPANE	X		X	X		X	X	X	X	X		E	
2-ETHOXYETHANOL	G		G	C		C	C	G		X		E	
2-ETHOXYETHYL ACETATE	G	X	G	X	X	X	X	X	G	X		E	
2-ETHYL (BUTYRALDEHYDE)	G			X		X		X				E	
2-ETHYL-1-HEXANOL	E		E	E		E	E	E		E	E	E	
2-ETHYLHEXANOIC ACID	C			G		C		C				E	
2-ETHYLHEXYL ACETATE	E			E		X		X				E	
2-OCTANONE	G			X		X		X				E	
3-BROMOPROPENE	X			X		X	X	X				E	
3-CHLORO-2-METHYL PROPANE		G											
3-CHLOROPROPENE	C		X	X		X	X	G		E		E	
4-HYDROXY-4-METHYL-2-PENTANONE	E		E	C	C	C	C	X	G	C		E	
ACETALDEHYDE	E		E	C	G		X	X	E	X	E	E	G
ACETAMIDE			E				G						E
ACETIC ACID, GLACIAL	G	E	G	C	E	X	X	G	X	C	G	E	E
ACETIC ACID 10 %	E	E	E	E	X	B	B	X	E	F	B	E	E
ACETIC ACID 30 %			E				G						E
ACETIC ACID 50 %	E	E	E	E	C	X	C	C	C	X		G	E
ACETIC ANHYDRIDE	G	E	G	E	C	C	G	X	X	X	G	E	G
ACETIC OXIDE	G		B	E		X					B	E	E
ACETONE	E	G	E	X	C	C	X	X	E	C	E	E	E
ACETONE CYANOHYDRIN	E			C		C	B	X			E	E	G
ACETONITRILE	E		E	G		B	E	C			E	E	
ACETOPHENONE	G		E	X		X	X	X		X	E	F	X
ACETYL ACETONE	E	G	E	X		X	X	X		X	E	E	E
ACETYL CHLORIDE	X	E	C		X		X	X	X	X	C	E	G
ACETYL OXIDE	E		G	X		C		X			G	E	E
ACETYLENE	E	G	E	C	G	G	E	E	E	C	E	E	E
ACETYLENE DICHLORIDE	C		C	X		X	X	X				E	
ACETYLENE TETRACHLORIDE	X		X	X		X	X	X				E	
ACROLEIN	E		E	G		G	C	C		C		E	X
ACRYLIC ACID		E											
ACRYLONITRILE	X	E	X	C		C			E	C		E	C
ADIPIC ACID			E			E	E	E				E	
AIR +149 °C (+300 °F)	G		G	G		X	G	G		X	E		X
ALK-TRI	X			X		X		X				E	
ALLYL ALCOHOL	E		E	E		E	E	E				E	E
ALLYL BROMIDE	X			X		X						E	G
ALLYL CHLORIDE		G		X		X		G		G		E	G
ALUM	E	E	E	E		E	E	E	G			E	E
ALUMINUM ACETATE (AQ)	G	E	E			E	G	G		X		E	E
ALUMINUM CHLORIDE (AQ) 40 %	G	C				E	E	G	X			E	
ALUMINUM FLUORIDE	E		E	E		E	E	E	G	E		E	E
ALUMINUM FORMATE	G			X		X						E	E
ALUMINUM HYDROXIDE	E		E	G		E	E	E	G	G		E	E
ALUMINUM NITRATE (AQ)	E	E	E	E		E	E	E		E		E	E
ALUMINIUM PHOSPATE			E				E						B

E = excellent; G = good; C = conditional; X = unsatisfactory

\* compounds not in catalogue. Ask Parker for right solution

## Chemical Resistance Table

Chemical or Material Conveyed	Butyl	CPE	EPDM	CSM	TPC-ET	Natural	Neoprene	Nitrile	Nylon	SBR	TPV	PTFE	UHMWPE
ALUMINUM SULFATE (AQ)	E	E	E	E	G	E	E	E	E	G	E	E	E
ALUMS-NH3-CR-K	E		E	E		E	E	E	C	E		E	E
AMINES – MIXED	G		G	X	G	G		X		G			
AMINO XYLENE	G		C										
AMINO BENZENE		G							C				
AMINODIMETHYLBENZENE	G	C										E	
AMINOETHANE	G		E	C		C	X	X		C		E	
AMMONIA LIQUID			E				E						G
AMMONIUM ANHYDROUS			E				E						G
AMMONIUM CARBONATE (AQ)	E		E	G		E	E	G	G	E		E	
AMMONIUM CHLORIDE (AQ)	E	G	E	G	E	E	E	G		E	E	E	E
AMMONIUM HYDROXIDE	E	E	E	E								E	E
AMMONIUM NITRATE (AQ)	E	G	E	E	G	E	E	E	G	E		E	E
AMMONIUM PHOSPHATE, DIBASIC	E	E	E	E		E	E	E	E	E		E	E
AMMONIUM SULPHATE (AQ)	E	E	E	E	G	E	E	E	G	G		E	E
AMMONIUM SULPHITE	E		E	E		E	E	E		E		E	
AMMONIUM THIOSULPHATE	E		E	E		E	E	E				E	
AMYL ACETATE	G		E	X	C	X	X	X	G	X	X	E	E
AMYL ACETONE	G			X		X						E	
AMYL ALCOHOL	E	E	E	E	E	E	E	G	E	E	E	E	E
AMYL AMINE	G			C		C		C				E	
AMYL BROMIDE												E	
AMYL CHLORIDE	X	C	X	X		X	X		E	X		E	E
AMYL ETHER				C				C				E	
ANETHOL	X	X		X		X			G			E	G
ANILINE	E	G	G	X	X	X	X	X	C	X		E	E
ANILINE DYES	G		G	G		G	C	X	X	G		E	E
ANILINE OIL	G	G	C									E	
ANIMAL FATS	C		E	C	G		G	E	E	X	E	E	E
ANTIMONY CHLORIDES	E		E	G			X	G				E	
AQUA REGIA	X		G	X		X	X	X		X		E	X
ARGON	G		E	X	E	X	X	E	E	X		E	E
AROMATIC HYDROCARBONS													C
ARSENIC ACID	E	E	E	E		G	E	E	G	E		G	E
ASPHALT	X		X	X	C	X	X	X	E	X	E	E	X
ASTM FUEL A	X	E	X	G	E	X	G	E	E	X	X	E	G
ASTM FUEL B	X	G	X	X	E	X	X	X	E	X	X	E	G
ASTM FUEL C	X	C	X	X	E	X	X		E	X	X	E	G
ASTM OIL NO. 2	X	E	X	X	E	X	G	E	E	X	X	E	E
ASTM OIL NO. 3	X		X	G	E	X	C	E	E	X	X	E	E
ASTM OIL NO. 4	X		X	X		X	X	G		X			E
ASTM OIL NO. 1	X	E	X	G	E	X	E	E	E	X	X	E	E
AUTOMATIC TRANSMISSION FLUID	X		X	C	E	X	G	E	G	X	X	E	E
BANANA OIL			G	C				X		X		E	E
BARIUM CHLORIDE (AQ)	E	G	E	E	G	E	E	E	G	E		E	E
BARIUM HYDROXIDE (AQ)	E	G	E	E	G	E	E	E	G	E		E	E
BARIUM SULFIDE (AQ)	E		E	E		E	E	E		G		E	E
BEER	E		E	E		E	G	E		E		E	E
BEET SUGAR LIQUORS	E	G	E	E	G	E	G	E	E	E		E	E
BENZAL CHLORIDE	G											E	E
BENZALDEHYDE	G		E	X	G	X	X	X	E	X	X	E	E
BENZENE	X	C	X	X	C	X	X	X	G	X	X	E	G
BENZENE CARBOXYLIC ACID	E			X			E	X				E	
BENZINE	X		X	X		X	C	C	G	X		E	
BENZOIC ACID	X					X	E	X	E	X		E	E
BENZOL		C	X		C			X	G			E	G
BENZOTRICHLORIDE												E	G
BENZYL ACETATE	E			G		X						E	E
BENZYL ALCOHOL	G		G	G	C	X	X	X	C	X	X	E	E
BENZYL CHLORIDE	X	X	X	X		X	X	X		X		E	E
BENZYL ETHER	G		C	X		X	X	X		X		E	
BIS (2-CLOROETHYL) ETHER	X			X		X		X		X		E	
BLACK SULFATE LIQUOR	G	C	G	G	G	G	G	G	C	G		E	E
BLEACH (2 – 15 %)	G		E	E	G	X	X	X	C	X		E	E
BORAX SOLUTION	E	G	E	E	E	G	E	G	G	G		E	E
BORIC ACID	E		E	E	E	E	E	E	E	G	E	E	E

E = excellent; G = good; C = conditional; X = unsatisfactory

\* compounds not in catalogue. Ask Parker for right solution



Chemical or Material Conveyed	Butyl	CPE	EPDM	CSM	TPC-ET	Natural	Neoprene	Nitrile	Nylon	SBR	TPV	PTFE	UHMWPE
BRAKE FLUID (HD-557) 12 DAYS	G	E	E	G			G	C	E	E		E	
BRINE	E	G	E	E	G	E	G	E	G			E	E
BROMACIL			E										
BROMOBENZENE	X	X	X	X		X	X	X		X		E	C
BROMOCHLOROMETHANE	X	X	G	X		X	X	X				E	
BROMOETHANE	X	X	X	X		C	X	G		X		E	
BROMOTOLUENE	X	X		X		X				X		E	
BUGDIOXANE													
BUNKER OIL	X		X	X		X	X	E		X		E	E
BUTADIENE	X		X	X		X	X	X		X		E	E
BUTANE	X		X	X	E	X	C	E	E	X		E	E
BUTANOIC ACID			G	C								E	
BUTANOL (BUTYL ALCOHOL)	G	G	G	E	G	E	E	E	G	E	G	E	E
BUTANONE	E	G	E	X	E			X	G		X	G	E
BUTOXYETHANOL	E		E	X		X	X	C				E	
BUTYL ACETATE	X	C	X	X	C	X	X	X	G	X		X	E
BUTYL ACRYLATE	X		X	X		X	X	X				E	G
BUTYL ALCOHOL	G	G	G	E	G	E	E	E	G	E	G	E	E
BUTYL ALDEHYDE	G		G	C			C				G	E	E
BUTYL BENZYL PHTHALATE	E			X		X				X		E	E
BUTYL CARBITOL	E		E	X		X	C	X		X		E	E
BUTYL CELLOSOLVE	E		G	X		X	X	C		X	E	E	E
BUTYL CHLORIDE	C			X		X						E	C
BUTYL ETHER	X		X	X		X	X	X		X		E	E
BUTYL ETHER ACETALDEHYDE	G			X		X			X			E	E
BUTYL ETHYL ETHER	X			X		X		G				E	E
BUTYL OLEATE	G		G	X		X	X	X		X		E	
BUTYL PHTHALATE	G		E	X		X				X		E	
BUTYL STEARATE	X		X	X		X	X	G		X		E	E
BUTYLENE	X		X	X	G	X	C	E	G	X		E	
BUTYRALDEHYDE	G		C			X	X	X		X			E
BUTYRIC ACID	G		G	C		X	X	X		X		E	E
BUTYRIC ANHYDRIDE	C			G		C		C				E	
CADMIUM ACETATE	E			E		X						E	E
CALCIUM ACETATE	E			C		E	G	G		X		E	E
CALCIUM ALUMINATE	E			E		E		E				E	
CALCIUM BICHROMATE	E			C								E	
CALCIUM BISULFIDE			X		G		C	E	G	G		E	
CALCIUM CHLORATE			E				E						E
CALCIUM CHLORIDE	E	G	E	E	E	E	E	E	E	E		E	E
CALCIUM HYDROXIDE	E	G	E	G	E	E	E	E	E	E		E	E
CALCIUM HYPOCHLORITE	E	G	E	E	C	X	C	X	X	X		E	C
CALCIUM NITRATE	E		E	E		E	E	E	E	E		E	E
CALCIUM SULFIDE	E	X	E	E		X	E	E	E	X		E	E
CAPRILIC ACID	C			G		C		C				E	E
CARBAMIDE	G			E		E	G	G				E	
CARBITOL	E		G	G		X	C	G	E	G		E	E
CARBOLIC ACID (PHENOL)	G	G	X	X		X	X	X	X	X	X	E	E
CARBON DIOXIDE	G		G	G		G	G	E	E	G		E	E
CARBON DISULFIDE	X		X	X		X	X	X	X	X		E	E
CARBON MONOXIDE	E	G	E	E	E	C	E	E	E	G	E	E	E
CARBON TETRACHLORIDE	X	C	X	X	X	X	X	C	X	X	X	E	G
CARBON TETRAFLUORIDE			G										B
CARBONIC ACID	E	X	E	E	X	E	G	G	G	G	X	E	
CASTOR OIL	G	G	G	E	C	E	E	E	G	E	C	E	E
CAUSTIC SODA (SEE SODIUM HYDROXIDE)	E		E		C		E		G		E	E	
CELLOSOLVE ACETATE	G		G	X		X	X	X	G	X		E	E
CELLUGUARD	E		E	X		E	E	E	G	E		E	
CELLULOSE ACETATE							X						B
CETYLIC ACID	G	G	G	C	E	E	G	E	C	B	E	E	
CHINA WOOD OIL (TUNG OIL)	X	C	X	E	G	X	E	E	G	X		E	
CHLORDANE	X		X	C	C	X	C	G	G	X			
CHLORINATED SOLVENTS	X	X	X	X		X	X	X	X	X		E	
CHLORINE GAS (DRY)							C						C
CHLORINE WATER SOLUTION (MAX. 3 %) + G108													E
CHLORO-2-PROPANONE	X		E	X		X	C	X		X		E	

E = excellent; G = good; C = conditional; X = unsatisfactory

\* compounds not in catalogue. Ask Parker for right solution

## Chemical Resistance Table

Chemical or Material Conveyed	Butyl	CPE	EPDM	CSM	TPC-ET	Natural	Neoprene	Nitrile	Nylon	SBR	TPV	PTFE	UHMWPE
CHLOROACETIC ACID	G		G	G	X	X	X	X	X	X	X	E	E
CHLOROACETONE	X		E	X	X	X	C	X		X		E	E
CHLOROBENZENE, MONO, DI, TRI	X		X	X	X	X	X	X	E	X	X	E	G
CHLOROBUTANE	C		X	X		X		X				E	G
CHLOROETHYLBENZENE	X	X	X	X		X				X		E	E
CHLOROFORM	X	X	X	X	X	X	X	X	X	X	X	E	E
CHLOROPENTANE	C			X		X				X		E	E
CHLOROPHENOL													B
CHLOROSULFONIC ACID	X	X	X	X	X	X	X	X	X	X	X	E	X
CHLOROTOLUENE	X		X	X		X	X	X		X		E	G
CHLOROXY	G		G	G		X	G	G		X		E	G
CHROME PLATING SOLUTIONS	X		X	X		X	X	X		X		E	
CHROMIC ACID	G	X	X	X	X	X	X	X	X	X	X	E	
CHROMIUM TRIOXIDE	G	X	X	X	X	X	X	X	X	X	X	E	
CINNAMENE	X		X	X	X	X	X	X		X		E	
CIS-9-OCTADECENOIC ACID	X	X	C	G	E	X	C	E	E	X		E	
CITRIC ACID	E	X	E	E	G	E	E	E	G	E		E	E
COAL OIL	X		X	C		X	G	E	E		X	E	E
COAL TAR	X		X	X	X	X	C	G		X	X	E	E
COAL TAR NAPHTHA	X		X	X		X		X		X		E	
COCONUT OIL	G		G	C		X	C	E		X		E	E
COKE OVEN GAS	X		X	X		X	X	X	E	X		C	
COOLANOL (MONSANTO)	X		X	G	X	X	G	E		X			
COPPER CHLORIDE	E	X	E	G	E	G	G	E	C	E		E	E
COPPER CYANIDE	E		E	G		E	E	E	G	E		E	E
COPPER HYDRATE	E			G		C		G				E	E
COPPER HYDROXIDE	E			G		C		G		G		E	
COPPER NITRATE			E				E						E
COPPER SULFATE	E	X	E	E	E	G	E	E	G	G		E	E
CORN OIL	G		X	G	E	X	C	E	G	X	E	E	E
COTTONSEED OIL	C	G	C	G	E	X	C	G	E	X		E	E
CREOSOTE	X		X	X		X	X	G	X	X		E	E
CRESOLS	X		X	X	X	X	X	X	X	X	X	E	E
CRESYLIC ACID	X		X	X		X	X	X		X		E	E
CROTONALDEHYDE	E		E	X		X	X	X		C		E	E
CRUDE OIL			X			X	X	G	E	X		E	E
CUMENE	X		X	X		X	X	X		X		E	E
CUPRIC CARBONATE	E			E		C	E	E				E	E
CUPRIC HYDROXIDE	E			G		C		G				E	
CUPRIC NITRATE	E		E	E		G	E	E				E	E
CUPRIC SULFATE	E		E	E		G	E	E		E		E	E
CUTTING OIL	X		X	G		X	G	E		X		E	
CYCLOHEXANE	X		X	X	E	X	X	G	G	X	X	E	E
CYCLOHEXANOL	X		X	B		X	G	G	G	X	X	E	E
CYCLOHEXANONE	X		C	X		X	X	X	G	X	X	E	E
CYCLOPENTANE	X		X	X		X	E	G				E	E
CYCLOPENTANOL	X		X	X		X		G		X			E
CYCLOPENTANONE	X			X		X		X				E	
CYCLOPENTYL ALCOHOL	X			X		X		G		X			E
DDT IN DEIONIZED KEROSENE	X		X	X		X	C	E	E	X		E	
DECAHYDRONAPHTHALENE	X		X	X		X	X	X	G	X	X	E	
DECAHYDROXYNAPHTHALENE		C											
DECALIN	X		X	X		X	X	X	G	X	X	E	X
DECYL ALCOHOL	X			E		X	X	E				E	E
DECYL ALDEHYDE	C			X		X						E	E
DECYL BUTYL PHTHALATE	E			X		X		X				E	E
DECYL CARBINOL	E			E		E		E				E	
"DETERGENT, WATER SOLUTION"	E		E		G		G	E		G		E	E
DEVELOPING FLUID (PHOTO)	G		G	E	X	E	E	E		G		E	
DEXTRON	X		X	X		X	G	E		X			
DI(2ETHYLHEXYL) ADIPATE	E		G	X		X	X	X				E	
DI(2ETHYLHEXYL) PHTHALATE	G		G	X	E	X	X	X	E	X		E	
DIACETONE ALCOHOL	E		E	X	C	X	X	X		X		E	E
DIACETYLMETHANE	E	G	E	X		X	X	X		X	E	E	
DIALLYLPHTHALATE		G											
DIAMMONIUM PHOSPHATE	E	E	E	E		E	E	E		E		E	

E = excellent; G = good; C = conditional; X = unsatisfactory

\* compounds not in catalogue. Ask Parker for right solution



Chemical or Material Conveyed	Butyl	CPE	EPDM	CSM	TPC-ET	Natural	Neoprene	Nitrile	Nylon	SBR	TPV	PTFE	UHMWPE
DIAMYL NAPHTHALENE	E			X		X						E	
DIAMYL PHENOL	X			X		X		X		X		E	
DIAMYLAMINE	E		E	C		G		G		X		E	
DIAMYLENE	X			X		X	X	C	G			E	
DIBENZYL ETHER	G		C	X		X	X	X		X		E	E
DIBROMOBENZENE	X			X		X						E	G
DIBROMOMETHANE	X		C	X		X	X	X			X	E	
DIBUTYL ETHER	X		X	X		X	X	X		X		E	E
DIBUTYL PHTHALATE	C		E	X	G	X	X	X	E	X		E	E
DIBUTYL SEBACATE	G		G	X	G	X	X	X		X		E	E
DIBUTYLAMINE	X		X	X		X	X	X		X		E	E
DICALCIUM PHOSPHATE	E			E		E		E				E	
DICHLORO DIFLUORO METHANE	X	C	C	E	E	X	G	C	G	E	X	E	
DICHLORO ETHYLENE	C		X	X	X		X		C		X	E	
DICHLOROACETIC ACID	C			X		G						E	E
DICHLOROBUTANE	X		C	X		X	X	G		X		E	E
DICHLOROETHANE	C	X	X	X	X	X	X	X	C	X	X	E	
DICHLOROETHYL ETHER	X			X		X		X		X		E	
DICHLOROFUOROMETHANE													E
DICHLOROHEXANE	X			X		X						E	E
DICHLOROMETHANE	X		C	X	X	X	G	X	C	X	X	E	E
DICHLOROPENTANE	X			X		X	X	X		X		E	E
DICHLOROPROPANE	X			X		X	X	X				E	E
DICHLOROPROPENE												E	E
DICHLOROTOLUENE		X											
DIESEL OIL	X	E	X	C	G	X	C	E	E	X	X	E	E
DIETHANOLAMINE	E		E	C	X	G			G	X		E	E
DIETHYL ETHER	X		X	X	C	X	X	X	E	X	E	E	
DIETHYL KETONE	G		E	X		X	X					E	
DIETHYL OXALATE	X		X	X		X	X	X				E	
DIETHYL PHTHALATE	E			X		X						E	E
DIETHYL SEBACATE	G		G	C	E	X	X	X		X	E	E	
DIETHYL SULFATE	G		E	X		X	E	X		E		E	
DIETHYL TRIAMINE	E			C		G		G				E	
DIETHYLAMINE	G		G	C		G	G	C		G		E	E
DIETHYLBENZENE	X		X	X		X	X	X		X		E	E
DIETHYLENE GLYCOL	E		E	E	E	E	E	E		E		E	E
DIETHYLENE OXIDE	X		E									E	
DIETHYLENE TRIAMINE	E		E	C		G				X	E	E	E
DIHYDROXY DIETHYL ETHER	E		E	E		E	E	E				E	
DIHYDROXY SUCCINIC ACID	G		G	E		E	C	G				E	
DIISOBUTYL KETONE	G		E	X		X	X	X		X		E	E
DIISOBUTYLENE	X		X	X		X	C	E		X		E	
DIISODECYL PHTHALATE	E		E	X		X	X	X		X		E	E
DIISODECYL ADIPATE	E			X		X		X		X		E	E
DIISOOCTYL PHTHALATE	E		G	X		X						E	E
DIISOPROPANOLAMINE	E			C		G		G				E	
DIISOPROPYL ETHER	X		X	C		X	X	G		X		E	
DIISOPROPYL KETONE	E		E	X		X	X	X		X		E	
DIMETHYL PHTHALATE	G		G	X	E	X	X	X		X	G	E	E
DIMETHYL SULFATE	G			X				X				E	E
DIMETHYL SULFIDE	C					X		X				E	
DIMETHYLAMINE	G		X	X		X	X	X				E	E
DIMETHYLANILINE	X	C	G	X			X	X		X		E	G
DIMETHYLBENZENE	X	C	X	X	X		X	X	G	X	X	X	E
DIMETHYLBUTANE		G											
DIMETHYLCARBINOL	E		G	E		E	E	G				E	E
DIMETHYLFORMAMIDE			G										E
DIMETHYLKETONE	E	G	E	X	C		X	X	E	C	E	E	E
DIOCTYL ADIPATE	E		G	X		X	X	X				E	E
DIOCTYL PHTHALATE	G		G	X	E	X	X	X	E	X		E	E
DIOXALANES	X		G	X		X	X	X		X		E	E
DIOXANE	G		G	X		X	X	X	E	X		E	E
DIPENTENE	X		X	X		X	X	G		X		E	
DIPENTYLAMINE	E		E	C		G		G		X		E	

E = excellent; G = good; C = conditional; X = unsatisfactory

\* compounds not in catalogue. Ask Parker for right solution

## Chemical Resistance Table

Chemical or Material Conveyed	Butyl	CPE	EPDM	CSM	TPC-ET	Natural	Neoprene	Nitrile	Nylon	SBR	TPV	PTFE	UHMWPE
DI-P-MENTHA-1,8-DIENE	X		X	X		X	X	G		X		E	
DIPROPYLAMINE	E			C		G		G				E	
DIPROPYLENE GLYCOL	E			E		E		E				E	
DISODIUM PHOSPHATE	E		E	E		E		E				E	E
DIVINYL BENZENE	X			X		X				X		E	E
DOWELL INHIBITOR		G											
DOWFAX 2A1 SOLVENT		E											
DOWFAX 2A1 TA		E											
DOWFAX 6A1 SOLVENT		G											
DOWFAX 6A1 TA		E											
"DOWTHERM, A AND E"	X	X	X	X	G	X	X	X	X	X		C	E
DRY CLEANING FLUIDS	X		X	X			X	C		X		E	
DUCGKIRIOEBAANE	X												
DURO AW16, 31			X					E	E			E	
DURO FR-HD			X					E	E			E	
EHTYL BUTYL ACETATE	E			G		X		X				E	E
EHTYL DICHLORIDE	C		C	X		X	X	X		X		E	E
EHTYLENE DIBROMIDE	X		C	X		X	X	X		X		E	G
EPICHLOROHYDRIN			C										B
ETHANOIC ACID	G	E	E	C	C	X		C	C	G	C	E	E
ETHANOL (GRAIN ALCOHOL)	E	G	E	E	E	E	E	E	X	E	E	E	E
ETHANOLAMINE	G		G	X		G	G	G		X		E	E
ETHERS	X	G	C	X	X	X	X	X	E	X		E	E
ETHYL ACETATE	G	G	E	X	C	X	X	X	E	X	E	E	E
ETHYL ACETOACETATE	G		G	X		C	X	X		C		E	E
ETHYL ACETONE	G		G	X		X	X	X		X		E	E
ETHYL ACRYLATE	G		G	X		X	X	X		X		E	E
ETHYL ALCOHOL	E	G	E	E	E	E	E	E	X	E	E	E	E
ETHYL ALDEHYDE	G		E	C		X	X	X				E	E
ETHYL ALUMINUM DICHLORIDE	X			X		X		X				E	
ETHYL BENZENE	X		X	X		X	X	X		X		E	E
ETHYL BROMIDE	X		X	X		C	X	G		X		E	E
ETHYL BUTANOL	E			E		E		E				E	E
ETHYL BUTYL KETONE	G			X		X		X				E	E
ETHYL CELLULOSE	G		G	G	G	G	G	G	C	G		E	E
ETHYL CHLORIDE	E	X	E	C	X	C	X	E	E	G	X	E	G
ETHYL DIISOBUTYLTHIO-CARBAMATE						E				E			E
ETHYL ETHER	X	G	X	X		X	X	X	E	X		E	E
ETHYL FORMATE	G		G	G		X	G	X		X		E	E
ETHYL IODIDE	C		C	X		X	X	X				E	G
ETHYL OXALATE	X		C	X		C	X	X		X		E	E
ETHYL PHTHALATE	E			X		X		X				E	E
ETHYL SILCATE	E		E	G		G	E	E		G		E	E
ETHYLAMINE	G		E	C		C	X	X		C		E	E
ETHYLENE													E
ETHYLENE BROMIDE			C										B
ETHYLENE CHLORIDE													G
ETHYLENE CHLOROHYDRIN	G		G	C		C	G	X				E	E
ETHYLENE DIAMINE	E		E	G		G	E	G		G		E	E
ETHYLENE DIBROMIDE													B
ETHYLENE DICHLORIDE	C	X	X	C	X	X	X	X	C	X	X	E	G
ETHYLENE G MONOETHYL E ACETATE	E		E	X		C	X	C				E	
ETHYLENE G. MONOBUTYL ETHER	E		E	C		X	C	C		X		E	
ETHYLENE G. MONOHEXYL ETHER													
ETHYLENE G. MONOMETHYL ETHER	E		G	G		X	E	C				E	
ETHYLENE GLYCOL	E	G	E	E	E	E	E	E	E	E	E	E	E
ETHYLENE OXIDE	X	X	C	X	E	X	X	X	G	X		E	E
FATTY ACIDS	X		X	C	G	X	G	E	E	X	X	E	E
FERRIC BROMIDE	E			E		E		E				E	E
FERRIC CHLORIDE	E	X	E	E	G	E	E	E	C	E		E	E
FERRIC NITRATE	E		E	E		E	E	E	E	E		E	E
FERRIC SULFATE	E	X	E	E	E	E	E	E	E	E		E	E
FERROUS ACETATE	E			E		X		X				E	
FERROUS CHLORIDE	G		E	G	E	E	G	E	E			E	E
FERROUS SULFATE	E		E	E	E	E	E	E	E			E	E
FLOUROSILIC ACID	E		E	E		E	E	E		G	C	E	C

E = excellent; G = good; C = conditional; X = unsatisfactory

\* compounds not in catalogue. Ask Parker for right solution



TH23

Catalogue 4401/UK

Chemical or Material Conveyed	Butyl	CPE	EPDM	CSM	TPC-ET	Natural	Neoprene	Nitrile	Nylon	SBR	TPV	PTFE	UHMWPE
FLUOBORIC ACID	G		E	E		E	E	E		E		E	C
FLUORINE	X		E	X	X	X	X	X	X			G	X
FORMALDEHYDE	E	G	E	G	C		G	C	E	C	E	E	E
FORMALIN	E	G	E	G	C		G	C	E	C	E	E	
FORMIC ACID	E	X	E	E	C	C	E	C	X	E	E	E	E
FREON 113	X		X	E	E	X	E	E	X	G	X	E	
FREON 12	C	C	C	E	E	C	E	E	G	E	X	E	
FREON 22	X	C	E	E	X	C	E	X	G	E	X	E	
FREON 502	E		E			E	E	G	E	E			
FUEL A (ASTM)	X	E	X	G	E	X	G	E	E	X	X	E	G
FUEL B (ASTM)	X	G	X	X	E	X	X	X	E	X	X	E	G
FUEL C (ASTM)			X				C						G
FUEL OIL	X	E	X	C	G	X	G	E	G	X		E	E
FURALDEHYDE	E	E	G	C	G	X	C	X	C	X	E	E	
FURAN	X		X	X		X	X	X		X		E	
FURFURAL	E	E	G	C	G	X	C	X	C	X	E	E	E
FURFURAN	X		X	X		X	X	X		X		E	
FURFURYL ALCOHOL	G		G	X	G	X	X	X	G	X	E	E	E
GALLIC ACID	G		G	G	X	E	G	G	G	G		E	E
GALLOTANNIC ACID	G		E	E		E	E	E				E	
GAS, 100 OCTANE	X		X	X	E	X	C	E	G	X	X	E	C
GAS, COAL			E		G		E	X	E				
GASOLINE	X	E	X	X	E	X	X	E	G	X		E	G
GLACIAL ACRYLIC ACID													
GLUCONIC ACID	C			G		X		C				E	E
GLUCOSE	E		E	E	G	E	G	E	G	E		E	E
GLYCERINE	E	E	E	E	E	E	E	E	G	E	X	E	A
GLYCEROL	E	E	E	E	E	E	E	E	G	E	X	E	
GLYCOGENIC ACID	C			G		X		C				E	
GLYCOLS	E		E	E	C	E	E	E	G	E	G	E	E
GLYCONIC ACID	C			G		X		C				E	E
GLYCYL ALCOHOL	E	E	E	E	E	E	E	E	G	E	X	E	
GREASE, PETROLEUM BASE	X	E	X	X	E	X	C	E	E	X	X	E	E
GREEN SULFATE LIQUOR	E		E	G	X	G	G	G	X	G		E	E
HALON 1211							E	E					
HELIUM	E		E	E		E	E	E	E	E		E	
HEPTALDEHYDE	X			X		X		E				E	
HEPTANAL	X			X		X		E				E	E
HEPTANE	X	E	X	G	G	X	G	E	E	X		E	E
HEPTANE CARBOXYLIC ACID	C			G		X		C				E	
HEPTANOIC ACID		E											
HEPTANONE		C											
HEXADECANOIC ACID	G	G	G	C	E	E	G	E	C	B	E	E	
HEXALDEHYDE	G		E	C		X	E	X		X		E	E
HEXANE	X		X	E	E	X	E	E	E	X	E	E	G
HEXANOL	C		G	G		E	G	E		E		E	E
HEXENE	X		X	G		X	G	G		X		E	
HEXYL ALCOHOL	C		G	G		E	G	G		E		E	E
HEXYL METHYL KETONE	G			X		X		X				E	
HEXYLAMINE	G			C		C		C				E	
HEXYLENE GLYCOL	E		C	E		E	E	E				E	
HISTOWAX		E											
HYDRAULIC OIL, PETROLEUM		E	X	G	E	X	G	E	E		X	E	E
HYDRAULIC FLUID (PHOSPHATE ESTER BASE)			E				X						X
HYDRAULIC FLUID (POLYALKYLENE GLICOL BASE)			C				G						E
HYDRAZINE	E		E	G	X	X	G	G	X	G		E	
HYDROBROMIC ACID	E	X	E	E		E	X	X	X	X		E	G
HYDROCHLORIC ACID	E	X	C	C	C	C	C	C	C	X	E	E	E
HYDROCYANIC ACID	G	X	E	E	X	G	G	G	X	G	E	E	E
HYDROFLUORIC ACID	G	X	C	E	X	C	C	C	X	C	X	E	E
HYDROFLUOSILICIC ACID	E	X	E	E	G	E	G	G	X	G		E	G
HYDROGEN CHLORIDE ANHYDROUS		E											
HYDROGEN DIOXIDE (10 %)	C		G	G		G	X	C				E	
HYDROGEN GAS	E	C	E	E	E	G	E	E	E	G		E	E
HYDROGEN PEROXIDE 10 %	G		G	E	X	G	X	C	G	C		E	G
HYDROGEN PEROXIDE OVER 10 %	X	X	C	G	X	X	X	X	X	X		E	E

E = excellent; G = good; C = conditional; X = unsatisfactory

\* compounds not in catalogue. Ask Parker for right solution

## Chemical Resistance Table

Chemical or Material Conveyed	Butyl	CPE	EPDM	CSM	TPC-ET	Natural	Neoprene	Nitrile	Nylon	SBR	TPV	PTFE	UHMWPE
HYDROGEN SULFIDE (WET)	E	X	E	E	E	X	E	C	X	X		E	E
HYDROXY BENZENE	G		C	C		X	X	X				E	
HYDROXYISOBUTYRONITRILE		E											
HYDROXYTOLUENE		E											
HYVAR XL			E										
IMINODI-2-PROPANOL		E											
IMINODIETHANOL		E											
IODINE	G		G	G		X	X	G	E	G		E	G
IODINE PENTAFLUORIDE	X		X	X		X	X	X		X		E	C
JODOFORM			X			X	X	E		X			
ISOBUTANAL		G											
ISOBUTANE							X						E
ISOBUTANOL (ISOBUTYL ALCOHOL)			E				E						E
ISOBUTYL ACETATE			C										B
ISOBUTYLAMINE	E			C		C		X				E	
ISOBUTYLBROMIDE	X			X		X		X				E	
ISOBUTYLCARBINOL	E		E	E		E	E	E				E	
ISOBUTYLENE													E
ISOCYANATES					G			G	G				E
ISOCTANE	X	E	X	G	E	X	G	E	E	X	X	E	E
ISOPROPANOL			E				E						E
ISOPROPYL ACETATE	G		G	X	C	X	X	X	G	X		E	E
ISOPROPYL ALCOHOL	E		E	E	E	E	G	E	E	E		E	E
ISOPROPYL ETHER	X		X	C		X	X	G		X		E	E
JET FUELS	X		X	X		X	X	E	C	X	X	E	E
JP-4 OIL	X		X	X	E	X	X	E	C	X	X	E	E
KEROSENE	X	G	X	X	E	X	C	E	E	X	X	E	E
KETONES	G	G	E	C	X	C	X	X	E	G	X	E	E
LACQUER SOLVENTS	X	C	X	X	C	X	X	X	E	X		E	G
LACTIC ACID – COLD	E	X	E	E	X	E	E	E	E	E		E	E
LACTIC ACID – HOT			X	C	C	X	X	X	X	X		E	E
LARD	C		G	G	G	X	G	E	E	X	E	E	G
LAVENDER OIL	X		X	X		X	X	G		X		E	G
LEAD ACETATE	E		E	C		E	G	G		X		E	E
LEAD NITRATE	E		E	C		E	E	E		E		E	
LEAD SULFATE	E		E	E	G	E	E	G	E	X		E	E
LIME	E		E	E	G	E	E	E	G			E	
LIME BLEACH	E		E	G		E	G	E		E		E	
LIME SULFUR, WET	E		C	G		C	E	E					E
LIMONENE	X		X	X		X	X	X				E	E
LINOLEIC ACID	X		X	X		X	C	G		X		E	
LINSEED OIL	G	G	C	G	G	X	E	E	E	X		E	E
LIQUID PETROLEUM GAS													E
LIQUID SOAP			E				E						B
LUBRICATING OILS, SAE	X	G	X	X	E	X	C	E	E	X	X	E	E
LYE SOLUTIONS	E	C	E	E	C	E	E	C	G	G	C	E	
M E X	G	C	E	X	C	X	X	X	E	X	X	E	E
MAGNESIUM ACETATE	E		E	E		X	X	X		X		E	
MAGNESIUM CARBONATE			E				E						G
MAGNESIUM CHLORIDE	E	G	E	E	G	E	E	E	E	E		E	E
MAGNESIUM HYDRATE	E		E	E		E	G	G				E	E
MAGNESIUM HYDROXIDE	E	G	E	E	C	E	E	E	E	G		E	E
MAGNESIUM SULFATE	E	G	E	E	G	G	E	E	E	G		E	E
MAGNESIUM SULFITE	E		E	E		G	E	E		G			
MALEIC ACID	X		E	X		X	X	C		X		E	E
MALEIC ANHYDRIDE	X		X	X		X	X	X		X		E	
MALIC ACID	X		X	G		E	G	E	E	G		E	E
MANGANESE SULFATE	G		E	E		G	E	E				E	E
MAPP			G				E	E		G			
MERCURY	E	G	E	E	E	E	E	E	E	E		E	E
MERCURY VAPORS	E		E	E		C	C	E		E		E	
MESITYL OXIDE	C		G	X		X	X	X		X		E	E
METHALLYL ALCOHOL	E			E		E		E				E	
METHALLYL CHLORIDE		C											
METHANE			X				G						E
METHANE CARBOXYLIC ACID								SEE ACETIC ACID					

E = excellent; G = good; C = conditional; X = unsatisfactory

\* compounds not in catalogue. Ask Parker for right solution



Chemical or Material Conveyed	Butyl	CPE	EPDM	CSM	TPC-ET	Natural	Neoprene	Nitrile	Nylon	SBR	TPV	PTFE	UHMWPE
METHANOIC ACID	E	X	E	E	C	C	E	C	X	E	E	E	
METHANOL (METHYL ALCOHOL)	E	G	E	E	E	E	E	E	G	E	E	E	E
METHANOL (WOOD ALCOHOL)	E	G	E	E	E	E	E	E	G	E	E	E	E
METHOXY ETHANOL		E											
METHOXYETHOXY ETHANOL		E											
METHYL 1-2, 4-PENTANEDIOL		E											
METHYL ACETATE	G		G	C	C	X	C	X	E	X		E	E
METHYL ACETOACETATE	G		G	X		X	X	X				E	
METHYL ACETONE	G		E	X		C	X	X				E	E
METHYL ACETYLENE PROPADIENE			G				E	E		G			
METHYL ACRYLATE			G										B
METHYL ACRYLATE STAB.			G										B
METHYL ALCOHOL	E	G	E	E	E	E	E	E	G	E	E	E	E
METHYL ALLYL ALCOHOL	E			E		E		E				E	
METHYL ALLYL CHLORIDE	F	C		X		X				X			
METHYL AMYL CARBINOL	E			E		E		E				E	
METHYL BENZENE	X	C	X	X	C	X	X	X	E	X	X	E	
METHYL BROMIDE	C		C	X	X	X	X	G	G	X	X	E	G
METHYL BUTANE	X		X	X			X	E				E	
METHYL BUTANOL	E	E	E	E	E	E	E	E	E	G	E	E	E
METHYL BUTYL KETONE	E		E	X		X	X	X		X		E	E
METHYL CARBITOL	E			E		X		C				E	
METHYL CELLOSOLVE	G		G	C		X	G	C		X		E	E
METHYL CHLORIDE	X	C	X	X	X	X	X	X	C	X	X	E	E
METHYL CYANIDE	E		E	G		G	E	C				E	E
METHYL ETHYL KETONE	E	G	E	X	E	X	X	X	G	X	C	E	E
METHYL HEXANOL	E			E		E		E				E	E
METHYL ISOAMYL KETONE		C											
METHYL ISOBUTYL KETONE (MIBK)			G										G
METHYL METHACRYLATE	C		X	X		X	X	X	C	X	C	E	G
METHYL NORMAL AMYL KETONE	G			X		X		X				E	
METHYL PROPYL ETHER	X			G		X		X				E	
METHYL SALICYLATE	G		C			X	X	X				E	
METHYL STYRENE		C											
METHYL SULFIDE	C			X		X		X				E	
METHYL TERTIARY BUTYL ETHER	G	X					X	X		X		G	G
METHYL-1-PROPANOL	E		E	E		E	E	G		E		E	
METHYL-2-BUTANOL	E	E		E		E				E			
METHYL-2-BUTANONE	G	X	C	X	X	X	X	X	E	X		E	
METHYL-2-HEXANONE	G	C		X		X				X			
METHYL-2-PENTANOL	E		E	E		G	E	G				E	
METHYL-2-PENTANONE	C	X	G	X	X	X	X	X	G	X	X	E	
METHYL-2-PROPEN-1-OL	E		E	E		G	E	G				E	
METHYL-3-PENTEN-1-ONE		C											
METHYL-4-ISOPROPYL BENZENE		C											
METHYLALLYL ACETATE	E			G		X		X				E	
METHYLAMYL ALCOHOL	E		E	E		G	E	G				E	
METHYLCYCLOHEXANE	X			X		X		X				E	
METHYLENE BROMIDE	X		X	X		X	X	X				E	G
METHYLENE CHLORIDE	X		C	X	X	X	X	X	C	X	X	E	E
METHYLETHYL KETONE	E	G	E	X	E	X	X	X	G	X	C	E	E
METHYLHEXYL KETONE	G			X		X		X				E	
METHYLISOBUTYL CARBINOL	E		E	E		G	E	G				E	
METHYLISOBUTYL KETONE	C	X	G	X	X	X	X	X	G	X	X	E	E
METHYLISOPROPYL KETONE	G	X	C	X	X	X	X	X	E	X		E	
METHYLLACTONITRILE	E			C		C	B	X			E	E	
METHYLPHENOL	X		X	C		X	X	X				E	
METHYLPROPYL CARBINOL	E			E		E		E				E	
METHYLPROPYL KETONE	G		G	X		X	X	X		X		E	
MIL-A-6091	E		E	E		E	E	G		E			
MIL-E-9500	E		E	E		E	E	E		E			
MIL-F-16884	X		X	C		X	C	E		X			
MIL-F-17111	X		X	X		X	G	E		X			
MIL-F-25558B	X		X	G		X	G	E		X			
MIL-F-25576C	X		X	C		X	C	E		X			
MIL-F-7024A	X		X	X		X	X	E		X			

E = excellent; G = good; C = conditional; X = unsatisfactory

\* compounds not in catalogue. Ask Parker for right solution

## Chemical Resistance Table

Chemical or Material Conveyed	Butyl	CPE	EPDM	CSM	TPC-ET	Natural	Neoprene	Nitrile	Nylon	SBR	TPV	PTFE	UHMWPE
MIL-G-10924B	X		X	G		X	X	E		X			
MIL-G-25013D	X		X	G		X	G	E		X			
MIL-G-25537A	X		X	G		X	G	E		X			
MIL-G-4343B	C		C	G		C	G	G		C			
MIL-G-5572	X		X	X		X	X	E		X			
MIL-G-7711A	X		X	X		X	X	E		X			
MIL-H-13910B	G		E	G		G	G	G		E			
MIL-H-19457B	E		E	X		X	X	X		X			
MIL-H-22251	E		E	G		G	G	G		G			
MIL-H-27601A	X		X	C		X	G	G		X			
MIL-H-5606B	X		C	G		X	G	E		X			
MIL-H-6083C	X		X	G		C	G	E		X			
MIL-H-8446B	X		X	C		X	G	G		X			
MIL-J-5161F	X		X	X		X	X	G		X			
MIL-J-5624G (JP-3, JP-4, JP-5)	X		X	X		X	X	E		X			
MIL-L-15016	X		X	G		X	G	E		X			
MIL-L-17331D	X		X	G		X	G	E		X			
MIL-L-2104B	X		X	C		X	G	E		X			
MIL-L-21260	X		X	G		X	G	E		X			
MIL-L-23699A	X		X	C		X	C	G		X			
MIL-L-25681C	E		E	G		G	G	G		G			
MIL-L-3150A	X		X	G		X	G	E		X			
MIL-L-3545B	X		X	C		C	G	G		X			
MIL-L-4339C	X		X	X		X	X	E		X			
MIL-L-6082C	X		X	G		X	G	E		X			
MIL-L-6085A	X		X	X		X	X	G		X			
MIL-L-7870A	X		X	X		X	G	E		X			
MIL-L-9000F	X		X	C		X	G	E		X			
MIL-L-9236B	X		X	X		X	X	G		X			
MIL-O-5606								E					
MIL-O-7808	X		X	X		X	X	G		X		E	
MIL-P-27402	E		E	G		G	G	G		G			
MIL-S-3136B TYPE 1 FUEL	X		X	G		X	G	E		X			
MIL-S-3136B TYPE 2 FUEL	X		X	X		X	X	C		X			
MIL-S-3136B TYPE 3 FUEL	X		X	X		X	X	C		X			
MIL-S-3136B TYPE 4 OIL, LOWSWELL	X		X	E		X	E	E		X			
MIL-S-3136B TYPE 5 OIL, MEDSWELL	X		X	G		X	G	E		X			
MIL-S-3136B TYPE 6 OIL, HI SWELL	X		X	X		X	X	E		X			
MIL-S-81087	E		E	E		E	E	E		E			
MINERAL OIL	X	G	X	E	E	X	E	E	E	X	X	E	E
MINERAL SPIRITS	X		X	G		X	X	E		X		E	E
MOBILE HFA			X					E	E			E	
MOLTEN SULFUR	G		E	E		G	E	G				E	X
MONOBUTYL ETHER	X		X	X		X	C	C		X		E	
MONO-CHLOROACETIC ACID	G	X	C	X	X	C	E	X	X	X	X	E	
MONOCHLOROBENZENE	X		X	X	C	X	X	X	G	X	X	E	G
MONOCHLORODIFLUOROMETHANE	X	C	E	E	X	C	E	X		E	X	E	
MONOETHANOL AMINE	G		G	C		G	G	G		G		E	E
MONOETHYL AMINE	G		E	C		C	X	X		C		E	
MONOMETHYLAMINE	C		E	C		C	C	G				E	
MONOVINYL ACETATE			G										B
MORPHOLINE			X				X	X	X			E	
MOTOR OIL			X	G	G		G	E	G			E	E
MTBE	G	X					X	X		X		G	G
MURIATIC ACID	C	X	C	C	C	C	C	C	X	X	E	E	E
NA-K			X					X				X	
NAPHTHA	X	E	X	X	E	X	X	E	E	G	X	E	E
NAPHTHALENE	X	C	X	X	C	X	X	X	G	X	C	E	E
NAPHTHENIC ACIDS		E	X	X		X	X	G		X		E	
N-BUTANAL	G		G	C		X	C	X				E	
N-BUTYLAMINE	X		C	X		X	X	X		X		E	
N-BUTYLBENZENE				X		X		X				E	
N-BUTYLBROMIDE	X			X		X		X				E	
N-BUTYLBUTYRATE	E		E	X		X	X	X		X		E	
N-BUTYLCARBINOL	E	E	E	E	E	E	E	G	E	E	E	E	
NEOHEXANE	X			X		X		E				E	

E = excellent; G = good; C = conditional; X = unsatisfactory

\* compounds not in catalogue. Ask Parker for right solution

Chemical or Material Conveyed	Butyl	CPE	EPDM	CSM	TPC-ET	Natural	Neoprene	Nitrile	Nylon	SBR	TPV	PTFE	UHMWPE
NEON GAS	E		E	E		E	E	E	E	E	E	E	
NEU-TRI	X			X		X		X				E	
NICKEL ACETATE	E		E	X		E	G	G		X		E	E
NICKEL CHLORIDE	E	X	E	E	C	E	G	E	C	E		E	E
NICKEL NITRATE	E		E	E		E	E	E				E	E
NICKEL SULFATE	E	X	E	E	C	G	E	E	C	G		E	E
NIETYLENE						E							
NITRIC ACID, 10 %	E	X	E	G	C	X	G	X	C	X	E	E	E
NITRIC ACID, 13N	X	X	X	X	X	X	X	X	X	X		E	
NITRIC ACID, 13N + 5 %	X	X	X	X	X	X	X	X	X	X		E	
NITRIC ACID, UP TO 25 %	G	X	E	G	X	X	X	X	X	X		E	E
NITRIC ACID, 25 % - 40 %	C	X	G	C	X	X	X	X	X	X		E	G
NITRIC ACID, 40 % - 60 %	X	X	X	X	X	X	X	X	X	X		E	C
NITRIC ACID, CONC (16N)	X	X	X	X	X	X	X	X	X	X	X	E	E
NITRIC ACID, RED FUMING	C	X	X	X	X	X	X	X	X	X	X	E	X
NITRILOTRIETHANOL	G		E	E	X	G	X	C		G		E	
NITROBENZENE	G	C	X	X	X	X	X	X	C	X		E	E
NITROETHANE	G		G	C		G	C	X		G	E	E	E
NITROGEN	E		E	E		E	E	E		E		E	E
NITROMETHANE	G		G	C	C	G	X	X		C		E	E
NITROPROPANE			G										E
NITROUS OXIDE GAS	E		E	E		E	G	E	C			E	E
N-NONYL ALCOHOL	E			E		E		E				E	
N-OCTANE	X		X	X		X	C	E		X		E	G
NONANOIC ACID	E			X		X		E				E	
NONANOL	E			E		E		E				E	
N-SERV (75 % XYLENE)									E			E	
NUTO H								E	E			E	
NYVAC LIGHT			E					X	E			E	
O-AMINOTOLUENE		G											
OCTANOIC ACID	C			G		C		C				E	
OCTANOL	G		E	G		G	G	G		G		E	E
OCTYL ACETATE	E			E		X		X				E	E
OCTYL ALCOHOL	G		G	G		G	G	G		G		E	E
OCTYL ALDEHYDE	C			X		X		X				E	
OCTYL AMINE	E			C		C		C				E	
OCTYL CARBINOL	E			E		E		E				E	
OCTYLENE GLYCOL	E			E		E		E				E	
OIL-PETROLEUM	X	G	X	G	E	X	G	E	G	X	C	E	E
OLEIC ACID	X	X	C	G	E	X	C	E	E	X		E	E
OLEUM (FUMING SULFURIC ACID)	X	X	X	X	X	X	X	X	X	X		E	X
OLIVE OIL	G		G	G		X	G	E	E	X		E	G
ORTHO-DICHLOROBENZENE	X		X	X	X	X	X	X	E	X	X	E	
ORTHO-DICHLOROBENZOL	X		X	X	X	X	X	X	E	X	X	E	
ORTHOXYLENE	X	C	C	X	C	X	X	X	G	X	X	E	
OXALIC ACID	E	X	E	E	X	C	G	G	G	G	E	E	E
OXYDIETHANOL		E											
OXYGEN COLD			E				E						E
OZONE	G		E	E	C	X	C	X	C	X		E	C
PAINT THINNER	X		X	X		X	X	X	G	X		E	E
PALM OIL													E
PALMITIC ACID	G	G	G	C	E	E	G	E	C	B	E	E	E
PAPERMAKERS ALUM	E			E		E	E	E				E	G
PARA METHOXYPROPENYL BENZENE	X	X		X		X			G			E	
PARA-DICHLOROBENZENE	X		X	X		X	X	X		X		E	
PARAFFIN WAX	X		X	X		X	G	E		E			E
PARALDEHYDE	E		E	X		C	C	C				E	
PARAXYLENE	X		X	X		X	X	C				E	
PCB												E	
P-CYMENE	X	X	X	X		X	X	X		X		E	E
PELARGONIC ALCOHOL	E			E		E		E				E	
PENTACHLOROETHANE	X			X		X	X	X				E	
PENTADIONE		G											
PENTAMETHYLENE	X		X	X		X	E	G				E	
PENTANE	X		X	C	G	X	C	E	G	X		E	G
PENTANOL	E		E	E		E	E	E				E	

E = excellent; G = good; C = conditional; X = unsatisfactory

\* compounds not in catalogue. Ask Parker for right solution

## Chemical Resistance Table

Chemical or Material Conveyed	Butyl	CPE	EPDM	CSM	TPC-ET	Natural	Neoprene	Nitrile	Nylon	SBR	TPV	PTFE	UHMWPE
PENTANONE	G		G	X		X	X	X				E	
PENTASOL	E		E	E		E	E	G				E	
PENTYL ACETATE	G		E	X	C	X	X	X	G	X	X	E	
PENTYL ALCOHOL	E	E	E	E	E	E	E	G	E	E	E	E	
PENTYL BROMIDE													E
PENTYL CHLORIDE	X	C	X	X		X	X		E	X		E	
PENTYL ETHER				C				C				E	
PENTYLAMINE	G		X	C		C	X	C				E	
PERCHLORIC ACID-2N	G		G	G	X	X	G	X	X	X	X	E	
PERCHLOROETHYLENE	X	C	X	X	X	X	X	C	C	X	X	E	G
PERCHLOROMETHANE	X					X	X	X				E	
PETROLEUM CRUDE	X		X	G	C	X	G	E	G	X		E	E
PETROLEUM ETHER	X		X	X		X	C	E	E	X		E	
PETROLEUM OILS	X	G	X	G	E	X	G	E	G	X	C	E	E
PHENBO													E
PHENOL	G			X	X	X	X	X	X	X	X	E	E
PHENOLSULFONIC ACID	C			X		X		X				E	G
PHENYLAMINE	E		G	X		X	X	X				E	
PHENYLBROMIDE	X		X	X		X	X	X				E	
PHENYLBUTANE		C											
PHENYLCHLORIDE	X		X	X		X	X	X				E	
PHENYLETHYLENE	X		X	X	X	X	X	X		X		E	
PHENYLMETHANE	X		X	X		X	X	X				E	
PHENYLMETHANOL	G		G	G	C	X	X	X	C	X	X	E	E
PHENYLMETHYL ACETATE	E			G		X						E	E
PHOSPAHTE ESTERS	E	G	E	X	C	X	X	X	E	X	E	E	
PHOSPHORIC ACID 10 %	G	X	E	E			E	E	E	G	E	E	E
PHOSPHORIC ACID 10 % - 85 %	G	X	E	E	X	G	E	X	C	G		E	E
PHOSPHORUS TRICHLORIDE ACID	E		E	X		X	X	X		X		E	
PHTALIC ANHYDRIDE			E				E						
PICRIC ACID, H2O SOLUTION	C	X	C	E	X	C	C	C	X	G	X	C	
PINE OIL	X		X	X		X	X	G		X		E	E
PINENE	X		X	X		X	X	G		X		E	E
POLY CHLORINATED BIPHENOL													E
POLYETHYLENE GLYCOL E-400	E	E		E		E				E			E
POLYOL ESTER					X		G		G				
POLYPROPYLENE GLYCOL	E			E		E		E				E	
POLYVINYL ACETATE EMULSION (PVA)			E				G						B
POTASSIUM ACETATE	E		E	C		E	G	G	G	X		E	E
POTASSIUM BICARBONATE			E				E					E	E
POTASSIUM BISULFATE	E		E	E		E	E	E	G	G		E	E
POTASSIUM BISULFITE	E		E	E		E	E	E	G	G		E	E
POTASSIUM CARBONATE	E		E	E	X	E	E	E	C	E		E	E
POTASSIUM CHLORIDE	E	G	E	E	G	E	E	E	E	E		E	E
POTASSIUM CHROMATE	G		E	C		G	E	E	G	G		E	G
POTASSIUM CYANIDE	E	G	E	E	G	E	G	E	E	E		E	E
POTASSIUM DICHROMATE	E	X	E	E		C	E	E	G	G		E	G
POTASSIUM HYDRATE	E		G	E		G	G	G	G	G		E	
POTASSIUM HYDROXIDE	G	X	E	E	C	G	G	G	G	G	G	E	G
POTASSIUM NITRATE	E		E	E	G	E	E	E	G	E		E	E
POTASSIUM PERMANGANATE 5 %	E		E	G	X	E	E	C	X	G		E	E
POTASSIUM SILICATE	E		E	E		E	E	E	G	E		E	
POTASSIUM SULFATE	E		E	E	G	E	E	E	E	G		E	E
POTASSIUM SULFIDE	E		E	E		G	E	E	E	G		E	E
POTASSIUM SULFITE	E		E	E		G	E	E	E	G		E	
PRESTONE ANTIFREEZE	E	G	E	E	G	E	C	E	G	E	E	E	
PRODUCER GAS	X		X	G		X	G	E		X		E	
PROPANEDIOL	C		E	E		E	C	E		E		E	
PROPANETRIOL	E	E	E	E	E	E	E	E	G	E	X	E	
PROPANOL	E		E	E		E	E	E		E	E	E	
PROPANOLAMINE		E											
PROPANONE	E	G	E	X	C	C	X	X	E	C	E	E	
PROPEN-1-OL	E		E	E		E	E	E				E	E
PROPENEDIAMENE		E											
PROPENENITRILE	X					G	X	X				E	
PROPENYL ALCOHOL	E		E	E		E	E	E				E	E

E = excellent; G = good; C = conditional; X = unsatisfactory

\* compounds not in catalogue. Ask Parker for right solution



Chemical or Material Conveyed	Butyl	CPE	EPDM	CSM	TPC-ET	Natural	Neoprene	Nitrile	Nylon	SBR	TPV	PTFE	UHMWPE
PROPENYLANISOLE	X			X		X		X				E	
PROPIONIC ACID	E		E	G		E	C	C		X		E	
PROPIONITRILE	E		E			E	G	X			X	E	
PROPYL ACETATE	G		E	X		X	X	X		X		E	E
PROPYL ALCOHOL	E		E	E		E	E	E		E	E	E	E
PROPYL ALDEHYDE	G			X		C		X				E	E
PROPYL BENZENE		C											
PROPYL CHLORIDE	C			X		X		X				E	E
PROPYL ETHER		E											
PROPYL NITRATE	G		G	X		X	X	X		X		E	
PROPYLENE	X		X	X		X	X	X		X		E	
PROPYLENE DIAMINE	E			C		G		G				E	
PROPYLENE DICHLORIDE													C
PROPYLENE GLYCOL	C		E	E		E	C	E		E		E	E
PYDRAUL, 'E' SERIES	G		G	X	G	X	X	X	G	X		E	E
PYDRAULIC 'C'	X		X	X	C	X	X	X	E	X	E	E	
PYRIDINE			G										C
PYROLIGNEOUS ACID			G										G
RESIN OIL							X						B
QUINTOLUBRIC 822 SERIES	X		X			X	X	G					
RED OIL	X	X	C	G	E	X	C	E	E	X		E	
REFRIGERANT 11	X		X	E	E	X	X	G		X		E	
REFRIGERANT 12	C	C	C	E	E	C	E	E	G	E	X	E	
REFRIGERANT 22	X	C	E	E	X	C	E	X	G	E	X	E	
RESORCINOL			G		X		X		X	G	X	E	
SAE NO. 10 OIL	X	G	X	X	E	X	C	E	E	X	X	E	
SAL AMMONIAC	E	G	E	E	E	E	E	E	C	E		E	
SEA WATER	E		E	E	E	E	G	E	E	E	E	E	E
SEWAGE	G		E	E	G	G	G	E	E	G	G	E	E
SILICATE ESTERS	C		X	G	C	X	E	G	G	X		E	
SILICATE OF SODA	E		E	E		E	E	E				E	
SILICONE GREASE	E		E	E	E	E	E	E	E	E		E	
SILICONE OIL	E		E	E	G	C	E	E	E	E		E	E
SILVER NITRATE	E		E	E	E	E	E	G	E	E		E	E
SKYDROL 500 TYPE 2	G	G	E	X	G	X	X	X	G	X	E	E	
SKYDROL 500B	G	G	E	X	E		X		E		E	E	
SKYDROL 500C	G	G		X	E		X					E	
SKYDROL 7000 TYPE 2	E	G	E	X	X	X	X	X	E	X		E	
SOAP SOLUTIONS	G	G	E	E	E	G	G	E	E	G	E	E	E
SODA ASH	E	G	E	E	G	E	E	E	G	E		E	E
SODA LIME	E		E	G		E	G	G				E	E
SODA NITER	E	G	E	E	G	G	G	G	E	G		E	
SODA, CAUSTIC	E	C	E	E	C	G	E	C	G	E	C	E	E
SODIUM ACETATE	E		E	C		E	G	G	G	X		E	E
SODIUM ALUMINATE	E		E	E		G	E	E	G	G		E	E
SODIUM BICARBONATE	E		E	E	G	E	E	E	E	E		E	E
SODIUM BISULFATE	E	X	E	E	C	E	E	G	C	G		E	E
SODIUM BISULFITE	E		E	E	G	E	E	E	E	G		E	E
SODIUM BORATE	E		E	E	G	E	E	E	E	E		E	E
SODIUM CARBONATE 10 % - 15 %	G	G	E	E	G	E	E	E	G	E		E	E
SODIUM CHLORATE			E										
SODIUM CHLORIDE	G	G	E	E	E	E	E	E	G	E	C	E	E
SODIUM CYANIDE	E	G	E	E	G	E	E	E	E	E		E	E
SODIUM DICHROMATE	E		C	G		X	C	E	G	G		E	E
SODIUM FLUORIDE			E				E						C
SODIUM HYDRATE	E		E	G		E	G	G	G	G		E	
SODIUM HYDROCHLORITE	G		G	E		C	C	C	G	G		E	
SODIUM HYDROXIDE (CAUSTIC SODA)	E	C	E	E	C	E	G	C	G	G	C	E	E
SODIUM HYPOCHLORITE	G	X	G	G	C	X	C	X	X	C	C	E	E
SODIUM METAPHOSPHATE	G		E	G		E	G	E	E	E		E	E
SODIUM NITRATE	E	G	E	E	G	G	G	G	E	G		E	E
SODIUM PERBORATE	E	X	E	G	G	G	G	G	E	G		E	E
SODIUM PEROXIDE	E	X	E	G	G	G	G	G	X	G		E	E
SODIUM PHOSPHATE	E		E	E	G	E	C	E	C	E		E	E
SODIUM SILICATE	E	G	E	E	G	E	E	E	E	E		E	E
SODIUM SULFATE	E	G	E	E	G	G	E	E	E	G		E	E

E = excellent; G = good; C = conditional; X = unsatisfactory

\* compounds not in catalogue. Ask Parker for right solution



## Chemical Resistance Table

Chemical or Material Conveyed	Butyl	CPE	EPDM	CSM	TPC-ET	Natural	Neoprene	Nitrile	Nylon	SBR	TPV	PTFE	UHM WPE
SODIUM SULFIDE	E	G	E	E	G	G	E	E	E	G		E	E
SODIUM SULFITE	E		E	E		G	E	E	E	G		E	E
SODIUM THIOSULFATE	E		E	E		E	E	E	G	G		E	E
SOYBEAN OIL	C	G	X	E	G	X	E	E	E	X		E	E
STANNIC CHLORIDE	G	X	E	C	G	G	C	E	C	E		E	E
STANNIC SULFIDE	E		E	E		E	E	E	E			E	E
STANNOUS CHLORIDE	G		C	E	G	E	E	E	C	E		E	E
STANNOUS SULFIDE	E		E	E		E	E	E	E			E	E
STEARIC ACID	G	G	G	C	G	C	G	E	E	G	E	E	E
STODDARD SOLVENT	X	G	X	X	E	X	C	E	E	X	X	E	E
STYRENE MONOMER	X		X	X	X	X	X	X		X		E	G
SULFAMIC ACID	E		X	E		G	G	C				E	
SULFUR	F		F	F		X	X	X		X		E	E
SULFUR CHLORIDE	X	G	X	C	C	X	C	C	C	X		E	E
SULFUR DIOXIDE	G		E	C	X	C	X	X	X	C		E	G
SULFUR TRIOXIDE, DRY	G		G	C	X	C	X	X		X		E	X
SULFURIC ACID 60 % +93 °C (+200 °F)	X	X	X	X	X	X	X	X	X	X		E	X
SULFURIC ACID, 25 %	G	X	E	E	E	G	E	E	X	G	E	E	E
SULFURIC ACID, 25 % - 50 %	G	X	E	G	G	G	E	E	X	G		E	E
SULFURIC ACID, 50 % - 96 %	X	X	G	C	X	X	C	C	X	X		E	E
SULFURIC ACID, CONC. 96 % - 98 %	X	X	X	X	X	X	X	X	X	X		E	E
SULFURIC ACID, FUMING	X	X	X	X	X	X	X	X	X	X		E	X
SULFUROUS ACID, 10 %	E	X	E	E	C	G	G	C	C	G		E	E
SULFUROUS ACID, 10 % - 85 %	E	X	G	E	C	G	C	C	X	C		E	E
SUTAN												E	
TALL OIL	X		X	C		X	C	E		X		E	E
TALLOW	G		E	C		C	G	E		X		E	E
TANNIC ACID	E	X	E	E	G	E	E	E	G	G	E	E	E
TAR, BITUMINOUS	X	G	X	C	G	C	C	G	G	X		E	E
TAR, CAMPHOR	X	C	X	X	C	X	X	X	G	X	C	E	X
TARTARIC ACID	G	X	C	E	G	E	E	E	E	G	E	E	E
T-BUTYL AMINE			G	X									
TELONE 2													
TERPINOL	C	E	C	X		X	X	G		X		E	G
TERTIARY BUTYL ALCOHOL	G		G	G		G	G	G		G		E	E
TERTIARY BUTYL AMINE			G	X									
TERTIARY BUTYL MERCAPTAN	X		X	X		X	X	X		X		E	
TETRACHLOROENZENE	X		X			X		X				E	
TETRACHLOROETHANE	X		X	X		X	X	X		X	C	E	C
TETRACHLOROETHYLENE	X		X	X		X	X	C	C	X		E	G
TETRACHLOROMETHANE	X		X	X		X	X	X				E	
TETRACHLORONAPHTHALENE	X		X			X		X				E	
TETRAETHYLENE GLYCOL	E			E		E		E				E	
TETRAETHYLORHTOSILICATE	E					X	X	X				E	
TETRAHYDROFURAN	G		X	X	C	X	X	X	G	X	X	E	G
THF	G		X	X	C	X	X	X	G	X	X	E	G
TIN CHLORIDES	G		E	E		E	C	E				E	E
TITANIUM TETRACHLORIDE	X		X	X		X	X	C		X		E	G
TOLUENE	X	C	X	X	C	X	X	X	E	X	X	E	E
TOLUENE DIISOCYANATE (TDI)			E										B
TOLUIDINE	X			X		X		X				E	
TOLUOL	X	C	X	X	C	X	X	X	E	X	X	E	
TRANSFORMER OIL	X		X	C		X	G	E		X		E	E
TRANSMISSION 'A' OIL	X		X	G	G	X	G	E	G	X		E	
TRI (2-HYDROXYETHYL) AMINE	G		E	E	X	G	X	C		G		E	
TRIBUTYL AMINE	E			C		G		G				E	
TRIBUTYL PHOSPHATE	G		E	X	C	C	X	X	G	X		E	E
TRICHLOROACETIC ACID	G		G	C	X	C	X	C	X	X		E	E
TRICHLOROBENZENE	X			X		X	X	X		X		E	
TRICHLOROETHANE	X		X	X		X	X	X	X	X		E	
TRICHLOROETHYLENE	X	C	X	X	X	X	X	X	C	X	X	E	G
TRICHLOROMETHANE	X	X	X	X	X	X	X	X	C	X	X	E	
TRICHLOROTOLUENE								X				E	
TRICRESYL PHOSPHATE	E		E	X	C	C	C	X	G	X		E	E
TRITHANOLAMINE	G		E	E	X	G	X	C		G		E	E
TRITHYLAMINE	C		E			G	G	E		X		E	

E = excellent; G = good; C = conditional; X = unsatisfactory

\* compounds not in catalogue. Ask Parker for right solution



TH31

Catalogue 4401/UK

Chemical or Material Conveyed	Butyl	CPE	EPDM	GSM	TPC-ET	Natural	Neoprene	Nitrile	Nylon	SBR	TPV	PTFE	UHMWPE
TRIETHYLENE GLYCOL	E			E		E		E				E	
TRIHYDROXYBENZOIC ACID	G		G	G	X	E	G	G	G	G		E	
TRIMETHYL PENTANES (MIXED)	X	E	X	C	E	X	C	E	E	X	X	E	
TRIMETHYL PENTENE		E											
TRIMETHYLAMINE		E										E	E
TRINITROTOLUENE (TNT)							G						
TRISODIUM PHOSPHATE	E		E	E	E	E	E	E	E	E		E	
TRITOYL PHOSPHATE	E		E	X	C	X	X	X	G	X		E	
TUNG OIL	X	C	X	E	G	X	E	E	G	X		E	E
TUNG OIL (CHINA OIL)	C	C	X	E	G	X	E	E	G	X		E	E
TURBINE OIL			X				C						B
TURPENTINEX	X	G	X	X		X	X	X	E	X	X	E	G
UDMH	E		E	E		E	G	G		X		E	
UNDECYL ALCOHOL	E		E	E		E	E	E				E	
UREA	E		E	E	G	E	G	G	E			E	E
URETHANE FORMULATIONS								E	E			E	
URIC ACID					X				G		E	E	
VARNISH	X	C	X	X		X	X	G	E	X		E	
VEGETABLE OILS	C		C	G		X	C	E	G	X		E	E
VERSILUBE F44	E		E	E		E	E	E	E	E		E	
VERSILUBE F55	E		X	E		E	E	E	E	E		E	
VINEGAR	E		E	E	C	G	G	G	E	G		E	X
VINEGAR ACID		G											
VINYL ACETATE	E		G	C		X	X	X		X		X	E
VINYL BENZENE	X		X	X	X	X	X	X		X		E	E
VINYL CHLORIDE (GAS)	X		G			G						E	E
VINYL CYANIDE	X	E	X	C		C	C	X	E	C	X	E	
VINYL ETHER	X			G		X		G				E	E
VINYL STYRENE	X			X		X				X		E	E
VINYL TOLUENE	X			X		X		X				E	E
VINYL TRICHLORIDE	X			X		X	X	X				E	E
VITAL, 4300, 5310			X					X	E			E	
VM&P NAPHTHA	X		X	X		X	C	C				E	
WATER	E	G	E	E	E	E	G	E	E	G	E	E	E
WATER, BOILING	E		E	E	C		G	G	X	G	G	G	X
WATER, SODA					E			E			E	E	
WEMCO C	X		X	X		X	G	E		X			
WHISKEY	E		E	E	G	E	E	E	E	E		E	X
WHITE OIL	X		X	X		X	G	E		X		E	E
WHITE PINE OIL	X		X	X		X	X	G		X			
WINES	E		E	E	G	E	E	E	E	E		E	X
WOOD ALCOHOL	E		E	E		E	E	E		E		E	E
WOOD OIL	C		X	C	G	X	G	E	G	X		E	E
XENON	E		E	E		E	E	E		E		E	
XYLENE, XYLOL	X	C	X	X	C	X	X	X	G	X	X	E	C
XYLIDINE	G		C	X		X	X	C		X		E	G
ZEOLITES	E		E	E		E	E	E		E			
ZINC ACETATE	E		E	C		E	G	G		X		E	
ZINC CARBONATE	E		E	E		E	E	E				E	E
ZINC CHLORIDE	E	X	E	E	E	E	E	E	E	E		E	E
ZINC CHROMATE	E		E	C								E	
ZINC SULFATE	E	X	E	E	C	E	E	E	X	G		E	E

E = excellent; G = good; C = conditional; X = unsatisfactory

\* compounds not in catalogue. Ask Parker for right solution

# Chemical Resistance Guide for Silicone Hose

Chemical	*	Chemical	*	Chemical	*
Acetic acid, dilute, 10%	B	Isobutyl alcohol	A	Nitrobenzene	C
Acetic acid glacial	C	Isopropyl alcohol	A	Oleic acid	X
Acetic acid anhydride	I	Isooctane	X	Oleum	I
Acetone	X	Kerosene	X	Oxalic acid	B
Acetylene	C	Lacquers	X	Oxygen	X
Air 68 °F (20 °C)	A	Lacquers solvents	X	Palmitic acid	X
Air 150 °F (65 °C)	A	Lactic acid	A	Perchlorethylene	C
Aluminum chloride 150 °F (65 °C)	A	Linseed oil	A	Petroleum oils and crude 200 °F (95 °C)	X
Aluminum fluoride 150 °F (65 °C)	B	Lubricating oil, crude	C	Phosphoric acid, crude	C
Aluminum sulfate 150 °F (65 °C)	A	Lubricating oil, refined	C	Phosphoric acid, pure 45%	C
Alums 150 °F (65 °C)	A	Magnesium chloride 150 °F (65 °C)	A	Picric acid, molten	X
Ammonia gas, anhydrous	I	Magnesium hydroxide 150 °F (65 °C)	B	Picric acid, water solution	I
Ammonia 10%water solution	A	Magnesium sulfate 150 °F (65 °C)	A	Potassium chlorite	A
Ammonia 30%water solution	C	Mercuric chloride	A	Potassium cyanide	A
Ammonium chloride	C	Mercury	A	Potassium hydroxide	C
Ammonium hydroxide	C	Methyl alcohol, methanol	A	Potassium sulfate	A
Ammonium nitrate	A	Methyl chloride	X	Propane	X
Ammonium phosphate monobasic	A	Calcium chloride	A	Sewage	B
Ammonium phosphate dibasic	A	Calcium hydroxide	A	Soap solution	A
Ammonium phosphate tribasic	A	Calcium hypochlorite	C	Soda ash, sodium carbonate	A
Ammonium sulfate	A	Caliche liquors	B	Sodium bicarbonate, baking soda	A
Amyl acetate	X	Cane sugar liquors	A	Sodium bisulfate	A
Amyl alcohol	X	Carbolic acid, phenol	X	Sodium chloride	A
Aniline, Aniline oil	X	Carbon dioxide, dry-wet	A	Sodium cyanide	A
Aniline, dyes	X	Carbon disulfide	X	Sodium hydroxide to 50% at 140 °F	A
Asphalt	I	Carbon monoxide 140 °F (60 °C)	A	Sodium hypochlorite	B
Barium chloride 150 °F (65 °C)	A	Carbon tetrachloride	X	Sodium metaphosphate	A
Barium hydroxide 150 °F (65 °C)	A	Castor oil	A	Sodium nitrate	X
Barium sulfide 150 °F (65 °C)	A	Cellosolve acetate	X	Sodium perborate	B
Beer	A	CFC-12	I	Sodium peroxide	C
Beet sugar liquors	A	China wood oil, tung oil	X	Sodium phosphate, monobasic	X
Benzene, Benzol	X	Chlorine, dry/wet	X	Sodium phosphate, dibasic	X
Benzine, petroleum ether	X	Chlorinated solvents	X	Sodium phosphate, tribasic	X
Benzine, petroleum naphtha	X	Chloroacetic acid	I	Sodium silicate	A
Black sulfate liquor	A	Chlorosulfonic acid	X	Sodium sulfate	A
Blast furnace gas	A	Chromic acid	C	Sodium sulfide	A
Borax	B	Citric acid	A	Sodium thiosulfate, hypo	I
Boric acid	A	Coke oven gas	B	Soybean oil	A
Bromine	X	Copper chloride 150 °F (65 °C)	A	Stannic chloride	B
Butane	X	Copper sulfate 150 °F (65 °C)	A	Steam 450 °F (230 °C)	I
Butyl acetate	X	Corn oil	A	Stearic acid	A
Butyl alcohol, Butanol	C	Cottonseed oil	A	Sulfur	B
Calcium bisulfate	C	Creosote, coal tar	C	Sulfur chloride	C
Formaldehyde	B	Creosote, coal tar wood	X	Sulfur dioxide, dry	B
Formic acid	C	Creosols, cresylic acid	I	Sulfur trioxide, dry	B
Fuel oil	X	Dichlorobenzene	X	Sulfuric acid, 10%	X
Furfural	X	Dichloroethylene	X	Sulfuric acid, 11% - 75%	X
Gasoline, unleaded	X	Diesel fuel	X	Sulfuric acid, 76% - 95%	X
Gasoline + MTBE	X	Diethanolamine 20%	X	Sulfuric acid, fuming	X
Gasoline Hi Test + MTBE	X	Diethylamine	B	Sulfurous acid	X
Gelatin	A	Diisopropylamine	I	Tannic acid	B
Glucose	A	Diethylphthalate	X	Tar	B
Glue	A	Ethers	X	Tartaric acid	A
Glycerine, glycerol	A	Ethyl acetate	B	Toluene, Toluol	X
Green sulfate liquor	A	Ethyl alcohol	A	Trichloroethylene	X
HFC-134	I	Ethyl cellulose	C	Turpentine	X
Hydraulic fluids: Petroleum	C	Ethyl chloride	C	Urea, water solution	A
Hydraulic fluids: Phosphate ester alkyl	X	Ethyl glycol	A	Vinegar	A
Hydraulic fluids: Phosphate ester aryl	X	Ferric chloride 150 °F (65 °C)	A	Vinyl acetate	X
Hydraulic fluids: Phosphate ester blends	X	Ferric sulfate 150 °F (65 °C)	B	Water, acid mine	A
Hydraulic fluids: Silicate ester	X	Methyl ethyl ketone	X	Water, fresh	A
Hydraulic fluids: Water glycol	A	Methyl isopropyl ketone	C	Water, distilled	A
Hydrobromic acid	X	Milk	A	Whiskey and wines	A
Hydrochloric acid	X	MTBE	I	Xylene, xylol	X
Hydrocyanic acid	B	Mineral oils	A	Zinc chloride	A
Hydrofluoric acid	X	Natural gas	C	Zinc sulfate	A
Hydrofluosilicic acid	I	Nickel chloride 150 °F (65 °C)	A		
Hydrogen gas 140 °F (60 °C)	C	Nickel sulfate 150 °F (65 °C)	A		
Hydrogen peroxide	A	Nitric acid, crude	X		
Hydrogen sulfide, dry	X	Nitric acid, diluted 10%	C		
Hydrogen sulfide, wet	X	Nitric acid, concentrated 70%	X		

**\* Resistance**

 A = Good Resistance  
 B = Fair Resistance  
 C = Poor Resistance

# Rubber Hose Dimensional Tolerances

According to norms

EN ISO 7840		EN ISO 6134		UNI 7140	
On inside diameter		On inside diameter		On inside diameter	± 0.50 mm
I.D. 5 mm	± 0.50 mm	≤ I.D. 38 mm	± 0.50 mm	Length tolerance	± 1%
I.D. 8 – 19 mm	± 0.75 mm	> I.D. 38 mm	± 0.70 mm		
I.D. 25 mm	± 1.25 mm	On outside diameter			
I.D. 38 – 50 mm	± 1.50 mm	≤ O.D. 48 mm	± 1.00 mm		
Length tolerance	± 1%	O.D. 54 mm	± 1.20 mm		
		O.D. 69 mm	± 1.40 mm		
		Length tolerance	± 1%		
EN 12115		SAE J 30 R7		UNI EN ISO 1307	
On inside diameter		On inside diameter		On inside diameter	
I.D. 19 – 38 mm	± 0.50 mm	I.D. ≤ 9.5 mm	± 0.40 mm	I.D. ≤ 5 mm	± 0.60 mm
I.D. 50 mm	± 0.70 mm	I.D. > 9.5 mm	± 0.60 mm	I.D. 6 – 20 mm	± 0.80 mm
I.D. 63.5 – 100 mm	± 0.80 mm	On outside diameter		I.D. > 20 – 25 mm	± 1.20 mm
On outside diameter		O.D. ≤ 15.9 mm	± 0.60 mm	I.D. > 25 mm	± 1.60 mm
O.D. 31 – 51 mm	± 1.00 mm	O.D. > 15.9 mm	± 0.80 mm	Length tolerance	± 1%
O.D. 66 – 91 mm	± 1.20 mm	Length tolerance	± 1%		
O.D. 116 mm	± 1.60 mm				
Length tolerance	± 1%				
				RMA steel mandrel	
				On inside diameter	
				I.D. ≤ 38 mm	± 0.79 mm
				I.D. 40 – 120 mm	± 1.59 mm
				I.D. > 120 mm	± 2.00 mm
				On outside diameter	
				O.D. ≤ 125 mm	± 1.59 mm
				O.D. > 125 mm	± 2.00 mm
				<i>Tolerances on outside diameter are valid for hoses without a built-in helix only.</i>	
				Length tolerance	± 1%

# PVC Hose Dimensional Tolerances

ASPIREX		APERSPIR		VINITRESS	
On inside diameter	± 4 %	On inside diameter	± 1 %	On inside diameter	
On wall thickness	± 0.50 mm	On wall thickness	± 0.50 mm	I.D. ≤ 15 mm	± 0.50 mm
Length tolerance	± 1 %	Length tolerance	± 1 %	I.D. 16 – 19 mm	± 0.80 mm
				I.D. > 19 mm	± 1.00 mm
				On wall thickness	± 0.50 mm
				Length tolerance	± 1 %
				APERFRUT	
				On inside diameter	
				I.D. ≤ 16 mm	± 0.50 mm
				I.D. > 16 mm	± 1.00 mm
				Length tolerance	± 2 %

All other technical data are subject to a ± 5 % tolerance

## Parker Safety Guide

**Parker safety guide for selecting and using hose, tubing, fittings and related accessories**

Parker Publication No. 4400-B.1 / Revised: September, 2015

**WARNING**

Failure or improper selection or improper use of hose, tubing, fittings, assemblies, valves, connectors, conductors or related accessories ("Products") can cause death, personal injury and property damage. Possible consequences of failure or improper selection or improper use of these Products include but are not limited to:

- Fittings thrown off at high speed.
- High velocity fluid discharge.
- Explosion or burning of the conveyed fluid.
- Electrocution from high voltage electric powerlines.
- Contact with suddenly moving or falling objects that are controlled by the conveyed fluid.
- Injections by high-pressure fluid discharge.
- Dangerously whipping Hose.
- Tube or pipe burst.
- Weld joint fracture.
- Contact with conveyed fluids that may be hot, cold, toxic or otherwise injurious.
- Sparking or explosion caused by static electricity buildup or other sources of electricity.
- Sparking or explosion while spraying paint or flammable liquids.
- Injuries resulting from inhalation, ingestion or exposure to fluids.

Before selecting or using any of these Products, it is important that you read and follow the instructions below. No product from any division in Fluid Connector Group is approved for in-flight aerospace applications. For hoses and fittings used in in-flight aerospace applications, please contact Parker Aerospace Group

**1.0 GENERAL INSTRUCTIONS**

Scope: This safety guide provides instructions for selecting and using (including assembling, installing, and maintaining) these Products. For convenience, all rubber and/or thermoplastic products commonly called "hose" or "tubing" are called "Hose" in this safety guide. Metallic tube or pipe are called "tube". All assemblies made with Hose are called "Hose Assemblies". All assemblies made with Tube are called "Tube Assemblies". All products commonly called "fittings", "couplings" or "adapters" are called "Fittings". Valves are fluid system components that control the passage of fluid. Related accessories are ancillary devices that enhance or monitor performance including crimping, flaring, flanging, presetting, bending, cutting, deburring, swaging machines, sensors, tags, lockout handles, spring guards and associated tooling. This safety guide is a supplement to and is to be used with the specific Parker publications for the specific Hose, Fittings and Related Accessories that are being considered for use. Parker publications are available at [www.parker.com](http://www.parker.com). SAE J1273 ([www.sae.org](http://www.sae.org)) and ISO 17165-2 ([www.ansi.org](http://www.ansi.org)) also provide recommended practices for hydraulic Hose Assemblies, and should be followed.

1.1 Fail-Safe: Hose, Hose Assemblies, Tube, Tube Assemblies and Fittings can and do fail without warning for many reasons. Design all systems and equipment in a fail-safe mode, so that failure of the Hose, Hose Assembly, Tube, Tube Assembly or Fitting will not endanger persons or property.

1.2 Distribution: Provide a copy of this safety guide to each person responsible for selecting or using Hose, Tube and Fitting products. Do not select or use Parker Hose, Tube or Fittings without thoroughly reading and understanding this safety guide as well as the specific Parker publications for the Products.

1.3 User Responsibility: Due to the wide variety of operating conditions and applications for Hose, Tube and Fittings. Parker does not represent or warrant that any particular Hose, Tube or Fitting is suitable for any specific end use system. This safety guide does not analyze all technical parameters that must be considered in selecting a product. The user, through its own analysis and testing, is solely responsible for:

- Making the final selection of the Products.
- Assuring that the user's requirements are met and that the application presents no health or safety hazards.
- Following the safety guide for Related Accessories and being trained to operate Related Accessories.
- Providing all appropriate health and safety warnings on the equipment on which the Products are used.
- Assuring compliance with all applicable government and industry standards.

1.4 Additional Questions: Call the appropriate Parker technical service department if you have any questions or require any additional infor-

mation. See the Parker publication for the Products being considered or used, or call 1-800-CPARKER, or go to [www.parker.com](http://www.parker.com), for telephone numbers of the appropriate technical service department.

**2.0 HOSE, TUBE AND FITTINGS SELECTION INSTRUCTIONS**

2.1 Electrical Conductivity: Certain applications require that the Hose be nonconductive to prevent electrical current flow. Other applications require the Hose and the Fittings and the Hose/Fitting interface to be sufficiently conductive to drain off static electricity. Extreme care must be exercised when selecting Hose, Tube and Fittings for these or any other applications in which electrical conductivity or nonconductivity is a factor. The electrical conductivity or nonconductivity of Hose, Tube and Fittings is dependent upon many factors and may be susceptible to change. These factors include but are not limited to the various materials used to make the Hose and the Fittings, Fitting finish (some Fitting finishes are electrically conductive while others are nonconductive), manufacturing methods (including moisture control), how the Fittings contact the Hose, age and amount of deterioration or damage or other changes, moisture content of the Hose at any particular time, and other factors. The following are considerations for electrically nonconductive and conductive Hose. For other applications consult the individual catalog pages and the appropriate industry or regulatory standards for proper selection.

2.1.1 Electrically Nonconductive Hose: Certain applications require that the Hose be nonconductive to prevent electrical current flow or to maintain electrical isolation. For applications that require Hose to be electrically nonconductive, including but not limited to applications near high voltage electric lines, only special nonconductive Hose can be used. The manufacturer of the equipment in which the nonconductive Hose is to be used must be consulted to be certain that the Hose, Tube and Fittings that are selected are proper for the application. Do not use any Parker Hose or Fittings for any such application requiring nonconductive Hose, including but not limited to applications near high voltage electric lines or dense magnetic fields, unless (i) the application is expressly approved in the Parker technical publication for the product, (ii) the Hose is marked "nonconductive", and (iii) the manufacturer of the equipment on which the Hose is to be used specifically approves the particular Parker Hose, Tube and Fittings for such use.

2.1.2 Electrically Conductive Hose: Parker manufactures special Hose for certain applications that require electrically conductive Hose. Parker manufactures special Hose for conveying paint in airless paint spraying applications. This Hose is labeled "Electrically Conductive Airless Paint Spray Hose" on its layline and packaging. This Hose must be properly connected to the appropriate Parker Fittings and properly grounded in order to dissipate dangerous static charge buildup, which occurs in all airless paint spraying applications. Do not use any other Hose for airless paint spraying, even if electrically conductive. Use of any other Hose or failure to properly connect the Hose can cause a fire or an explosion resulting in death, personal injury, and property damage. All hoses that convey fuels must be grounded. Parker manufactures a special Hose for

certain compressed natural gas ("CNG") applications where static electricity buildup may occur. Parker CNG Hose assemblies comply with the requirements of ANSI/IAS NGV 4.2; CSA 12.52, "Hoses for Natural Gas Vehicles and Dispensing Systems" (www.ansi.org). This Hose is labeled "Electrically Conductive for CNG Use" on its layline and packaging. This Hose must be properly connected to the appropriate Parker Fittings and properly grounded in order to dissipate dangerous static charge buildup, which occurs in, for example, high velocity CNG dispensing or transfer. Do not use any other Hose for CNG applications where static charge buildup may occur, even if electrically conductive. Use of other Hoses in CNG applications or failure to properly connect or ground this Hose can cause a fire or an explosion resulting in death, personal injury, and property damage. Care must also be taken to protect against CNG permeation through the Hose wall. See section 2.6, Permeation, for more information. Parker CNG Hose is intended for dispenser and vehicle use within the specified temperature range. Parker CNG Hose should not be used in confined spaces or unventilated areas or areas exceeding the specified temperature range. Final assemblies must be tested for leaks. CNG Hose Assemblies should be tested on a monthly basis for conductivity per ANSI/IAS NGV 4.2; CSA 12.52. Parker manufactures special Hose for aerospace in-flight applications. Aerospace in-flight applications employing Hose to transmit fuel, lubricating fluids and hydraulic fluids require a special Hose with a conductive inner tube. This Hose for in-flight applications is available only from Parker's Stratoflex Products Division. Do not use any other Parker Hose for in-flight applications, even if electrically conductive. Use of other Hoses for in-flight applications or failure to properly connect or ground this Hose can cause a fire or an explosion resulting in death, personal injury and property damage. These Hose assemblies for in-flight applications must meet all applicable aerospace industry, aircraft engine and aircraft requirements.

**2.2 Pressure:** Hose, Tube and Fitting selection must be made so that the published maximum working pressure of the Hose, Tube and Fittings are equal to or greater than the maximum system pressure. The maximum working pressure of a Hose, or Tube Assembly is the lower of the respective published maximum working pressures of the Hose, Tube and the Fittings used. Surge pressures or peak transient pressures in the system must be below the published maximum working pressure for the Hose, Tube and Fitting. Surge pressures and peak pressures can usually only be determined by sensitive electrical instrumentation that measures and indicates pressures at millisecond intervals. Mechanical pressure gauges indicate only average pressures and cannot be used to determine surge pressures or peak transient pressures. Published burst pressure ratings for Hose is for manufacturing test purposes only and is no indication that the Product can be used in applications at the burst pressure or otherwise above the published maximum recommended working pressure.

**2.3 Suction:** Hoses used for suction applications must be selected to insure that the Hose will withstand the vacuum and pressure of the system. Improperly selected Hose may collapse in suction application.

**2.4 Temperature:** Be certain that fluid and ambient temperatures, both steady and transient, do not exceed the limitations of the Hose, Tube, Fitting and Seals. Temperatures below and above the recommended limit can degrade Hose, Tube, Fittings and Seals to a point where a failure may occur and release fluid. Tube and Fittings performances are normally degraded at elevated temperature. Material compatibility can also change at temperatures outside of the rated range. Properly insulate and protect the Hose Assembly when routing near hot objects (e.g. manifolds). Do not use any Hose in any application where failure of the Hose could result in the conveyed fluids (or vapors or mist from the conveyed fluids) contacting any open flame, molten metal, or other potential fire ignition source that could cause burning or explosion of the conveyed fluids or vapors.

**2.5 Fluid Compatibility:** Hose, and Tube Assembly selection must assure compatibility of the Hose tube, cover, reinforcement, Tube, Plating and Seals with the fluid media used. See the fluid compatibility chart in the Parker publication for the product being considered or used. This information is offered only as a guide. Actual service life can only be determined by the end user by testing under all extreme conditions and other analysis. Hose, and Tube that is chemically compatible with a particular fluid must be assembled using Fittings and adapters containing likewise compatible seals. Flange or flare processes can change Tube material properties that may not be compatible with certain requirements such as NACE

**2.6 Permeation:** Permeation (that is, seepage through the Hose or Seal) will occur from inside the Hose or Fitting to outside when Hose

or Fitting is used with gases, liquid and gas fuels, and refrigerants (including but not limited to such materials as helium, diesel fuel, gasoline, natural gas, or LPG). This permeation may result in high concentrations of vapors which are potentially flammable, explosive, or toxic, and in loss of fluid. Dangerous explosions, fires, and other hazards can result when using the wrong Hose for such applications. The system designer must take into account the fact that this permeation will take place and must not use Hose or Fitting if this permeation could be hazardous. The system designer must take into account all legal, government, insurance, or any other special regulations which govern the use of fuels and refrigerants. Never use a Hose or Fitting even though the fluid compatibility is acceptable without considering the potential hazardous effects that can result from permeation through the Hose or Tube Assembly. Permeation of moisture from outside the Hose or Fitting to inside the Hose or Fitting will also occur in Hose or Tube assemblies, regardless of internal pressure. If this moisture permeation would have detrimental effects (particularly, but not limited to refrigeration and air conditioning systems), incorporation of sufficient drying capacity in the system or other appropriate system safeguards should be selected and used. The sudden pressure release of highly pressurized gas could also result in Explosive Decompression failure of permeated Seals and Hoses.

**2.7 Size:** Transmission of power by means of pressurized fluid varies with pressure and rate of flow. The size of the components must be adequate to keep pressure losses to a minimum and avoid damage due to heat generation or excessive fluid velocity.

**2.8 Routing:** Attention must be given to optimum routing to minimize inherent problems (kinking or flow restriction due to Hose collapse, twisting of the Hose, proximity to hot objects or heat sources). For additional routing recommendations see SAE J1273 and ISO 17165-2. Hose Assemblies have a finite life and should be installed in a manner that allows for ease of inspection and future replacement. Hose because of its relative short life, should not be used in residential and commercial buildings inside of inaccessible walls or floors, unless specifically allowed in the product literature. Always review all product literature for proper installation and routing instructions.

**2.9 Environment:** Care must be taken to insure that the Hose, Tube and Fittings are either compatible with or protected from the environment (that is, surrounding conditions) to which they are exposed. Environmental conditions including but not limited to ultraviolet radiation, sunlight, heat, ozone, moisture, water, salt water, chemicals and air pollutants can cause degradation and premature failure.

**2.10 Mechanical Loads:** External forces can significantly reduce Hose, Tube and Fitting life or cause failure. Mechanical loads which must be considered include excessive flexing, twist, kinking, tensile or side loads, bend radius, and vibration. Use of swivel type Fittings or adapters may be required to insure no twist is put into the Hose. Use of proper Hose or Tube clamps may also be required to reduce external mechanical loads. Unusual applications may require special testing prior to Hose selection.

**2.11 Physical Damage:** Care must be taken to protect Hose from wear, snagging, kinking, bending smaller than minimum bend radius and cutting, any of which can cause premature Hose failure. Any Hose that has been kinked or bent to a radius smaller than the minimum bend radius, and any Hose that has been cut or is cracked or is otherwise damaged should be removed and discarded. Fittings with damages such as scratches on sealing surfaces and deformation should be replaced.

**2.12 Proper End Fitting:** See instructions 3.2 through 3.5. These recommendations may be substantiated by testing to industry standards such as SAE J517 for hydraulic applications, or MIL-A-5070, AS1339, or AS3517 for Hoses from Parker's Stratoflex Products Division for aerospace applications.

**2.13 Length:** When determining the proper Hose or Tube length of an assembly, be aware of Hose length change due to pressure, Tube length change due to thermal expansion or contraction, and Hose or Tube and machine tolerances and movement must be considered. When routing short hose assemblies, it is recommended that the minimum free hose length is always used. Consult the hose manufacturer for their minimum free hose length recommendations. Hose assemblies should be installed in such a way that any motion or flexing occurs within the same plane.

**2.14 Specifications and Standards:** When selecting Hose, Tube and Fittings, government, industry, and Parker specifications and recommendations must be reviewed and followed as applicable.

**2.15 Hose Cleanliness:** Hose and Tube components may vary in cleanliness levels. Care must be taken to insure that the Hose and

## Parker Safety Guide

Tube Assembly selected has an adequate level of cleanliness for the application.

**2.16 Fire Resistant Fluids:** Some fire resistant fluids that are to be conveyed by Hose or Tube require use of the same type of Hose or Tube as used with petroleum base fluids. Some such fluids require a special Hose, Tube, Fitting and Seal, while a few fluids will not work with any Hose at all. See instructions 2.5 and 1.5. The wrong Hose, Tube, Fitting or Seal may fail after a very short service. In addition, all liquids but pure water may burn fiercely under certain conditions, and even pure water leakage may be hazardous.

**2.17 Radiant Heat:** Hose and Seals can be heated to destruction without contact by such nearby items as hot manifolds or molten metal. The same heat source may then initiate a fire. This can occur despite the presence of cool air around the Hose or Seal. Performance of Tube and Fitting subjected to the heat could be degraded.

**2.18 Welding or Brazing:** When using a torch or arc welder in close proximity to hydraulic lines, the hydraulic lines should be removed or shielded with appropriate fire resistant materials. Flame or weld spatter could burn through the Hose or Seal and possibly ignite escaping fluid resulting in a catastrophic failure. Heating of plated parts, including Hose Fittings and adapters, above 450°F (232°C) such as during welding, brazing or soldering may emit deadly gases. Any elastomer seal on fittings shall be removed prior to welding or brazing, any metallic surfaces shall be protected after brazing or welding when necessary. Welding and brazing filler material shall be compatible with the Tube and Fitting that are joined.

**2.19 Atomic Radiation:** Atomic radiation affects all materials used in Hose and Tube assemblies. Since the long-term effects may be unknown, do not expose Hose or Tube assemblies to atomic radiation. Nuclear applications may require special Tube and Fittings.

**2.20 Aerospace Applications:** The only Hose, Tube and Fittings that may be used for in-flight aerospace applications are those available from Parker's Stratoflex Products Division. Do not use any other Hose or Fittings for in-flight applications. Do not use any Hose or Fittings from Parker's Stratoflex Products Division with any other Hose or Fittings, unless expressly approved in writing by the engineering manager or chief engineer of Stratoflex Products Division and verified by the user's own testing and inspection to aerospace industry standards.

**2.21 Unlocking Couplings:** Ball locking couplings or other Fittings with quick disconnect ability can unintentionally disconnect if they are dragged over obstructions, or if the sleeve or other disconnect member, is bumped or moved enough to cause disconnect. Threaded Fittings should be considered where there is a potential for accidental uncoupling.

### 3.0 HOSE AND FITTINGS ASSEMBLY AND INSTALLATION INSTRUCTIONS

**3.1 Component Inspection:** Prior to assembly, a careful examination of the Hose and Fittings must be performed. All components must be checked for correct style, size, catalog number, and length. The Hose must be examined for cleanliness, obstructions, blisters, cover looseness, kinks, cracks, cuts or any other visible defects. Inspect the Fitting and sealing surfaces for burrs, nicks, corrosion or other imperfections. Do NOT use any component that displays any signs of nonconformance.

**3.2 Hose and Fitting Assembly:** Do not assemble a Parker Fitting on a Parker Hose that is not specifically listed by Parker for that Fitting, unless authorized in writing by the engineering manager or chief engineer of the appropriate Parker division. Do not assemble a Parker Fitting on another manufacturer's Hose or a Parker Hose on another manufacturer's Fitting unless (i) the engineering manager or chief engineer of the appropriate Parker division approves the Assembly in writing or that combination is expressly approved in the appropriate Parker literature for the specific Parker product, and

(ii) the user verifies the Assembly and the application through analysis and testing. For Parker Hose that does not specify a Parker Fitting, the user is solely responsible for the selection of the proper Fitting and Hose Assembly procedures. See instruction 1.4. To prevent the possibility of problems such as leakage at the Fitting or system contamination, it is important to completely remove all debris from the cutting operation before installation of the Fittings. The Parker published instructions must be followed for assembling the Fittings on the Hose. These instructions are provided in the Parker Fitting catalog for the specific Parker Fitting being used, or by calling 1-800-CPARKER, or at [www.parker.com](http://www.parker.com).

**3.3 Related Accessories:** Do not crimp or swage any Parker Hose or Fitting with anything but the listed swage or crimp machine and dies

in accordance with Parker published instructions. Do not crimp or swage another manufacturer's Fitting with a Parker crimp or swage die unless authorized in writing by the engineering manager or chief engineer of the appropriate Parker division.

**3.4 Parts:** Do not use any Parker Fitting part (including but not limited to socket, shell, nipple, or insert) except with the correct Parker mating parts, in accordance with Parker published instructions, unless authorized in writing by the engineering manager or chief engineer of the appropriate Parker division.

**3.5 Field Attachable/Permanent:** Do not reuse any field attachable Hose Fitting that has blown or pulled off a Hose. Do not reuse a Parker permanent Hose Fitting (crimped or swaged) or any part thereof. Complete Hose Assemblies may only be reused after proper inspection under section 4.0. Do not assemble Fittings to any previously used hydraulic Hose that was in service, for use in a fluid power application.

**3.6 Pre-Installation Inspection:** Prior to installation, a careful examination of the Hose Assembly must be performed. Inspect the Hose Assembly for any damage or defects. DO NOT use any Hose Assembly that displays any signs of nonconformance.

**3.7 Minimum Bend Radius:** Installation of a Hose at less than the minimum listed bend radius may significantly reduce the Hose life. Particular attention must be given to preclude sharp bending at the Hose to Fitting juncture. Any bending during installation at less than the minimum bend radius must be avoided. If any Hose is kinked during installation, the Hose must be discarded.

**3.8 Twist Angle and Orientation:** Hose Assembly installation must be such that relative motion of machine components does not produce twisting.

**3.9 Securement:** In many applications, it may be necessary to restrain, protect, or guide the Hose to protect it from damage by unnecessary flexing, pressure surges, and contact with other mechanical components. Care must be taken to insure such restraints do not introduce additional stress or wear points.

**3.10 Proper Connection of Ports:** Proper physical installation of the Hose Assembly requires a correctly installed port connection insuring that no twist or torque is transferred to the Hose when the Fittings are being tightened or otherwise during use.

**3.11 External Damage:** Proper installation is not complete without insuring that tensile loads, side loads, kinking, flattening, potential abrasion, thread damage or damage to sealing surfaces are corrected or eliminated. See instruction 2.10.

**3.12 System Checkout:** All air entrapment must be eliminated and the system pressurized to the maximum system pressure (at or below the Hose maximum working pressure) and checked for proper function and freedom from leaks. Personnel must stay out of potential hazardous areas while testing and using.

**3.13 Routing:** The Hose Assembly should be routed in such a manner so if a failure does occur, the escaping media will not cause personal injury or property damage. In addition, if fluid media comes in contact with hot surfaces, open flame or sparks, a fire or explosion may occur. See section 2.4.

**3.14 Ground Fault Equipment Protection Devices (GFEPDs):** WARNING! Fire and Shock Hazard. To minimize the danger of fire if the heating cable of a Multitube bundle is damaged or improperly installed, use a Ground Fault Equipment Protection Device. Electrical fault currents may be insufficient to trip a conventional circuit breaker. For ground fault protection, the IEEE 515: ([www.ansi.org](http://www.ansi.org)) standard for heating cables recommends the use of GFEPDs with a nominal 30 milliampere trip level for "piping systems in classified areas, those areas requiring a high degree of maintenance, or which may be exposed to physical abuse or corrosive atmospheres".

### 4.0 TUBE AND FITTINGS ASSEMBLY AND INSTALLATION INSTRUCTIONS

**4.1 Component Inspection:** Prior to assembly, a careful examination of the Tube and Fittings must be performed. All components must be checked for correct style, size, material, seal, and length. Inspect the Fitting and sealing surfaces for burrs, nicks, corrosion, missing seal or other imperfections. Do NOT use any component that displays any signs of nonconformance.

**4.2 Tube and Fitting Assembly:** Do not assemble a Parker Fitting with a Tube that is not specifically listed by Parker for that Fitting, unless authorized in writing by the engineering manager or chief engineer of the appropriate Parker division. The Tube must meet the requirements specified to the Fitting. The Parker published instructions must

be followed for assembling the Fittings to a Tube. These instructions are provided in the Parker Fitting catalog for the specific Parker Fitting being used, or by calling 1-800-CPARKER, or at [www.parker.com](http://www.parker.com).

**4.3 Related Accessories:** Do not preset or flange Parker Fitting components using another manufacturer's equipment or procedures unless authorized in writing by the engineering manager or chief engineer of the appropriate Parker division. Tube, Fitting component and tooling must be checked for correct style, size and material. Operation and maintenance of Related Accessories must be in accordance with the operation manual for the designated Accessory.

**4.4 Securement:** In many applications, it may be necessary to restrain, protect, or guide the Tube to protect it from damage by unnecessary flexing, pressure surges, vibration, and contact with other mechanical components. Care must be taken to insure such restraints do not introduce additional stress or wear points.

**4.5 Proper Connection of Ports:** Proper physical installation of the Tube Assembly requires a correctly installed port connection insuring that no torque is transferred to the Tube when the Fittings are being tightened or otherwise during use.

**4.6 External Damage:** Proper installation is not complete without insuring that tensile loads, side loads, flattening, potential abrasion, thread damage or damage to sealing surfaces are corrected or eliminated. See instruction 2.10.

**4.7 System Checkout:** All air entrapment must be eliminated and the system pressurized to the maximum system pressure (at or below the Tube Assembly maximum working pressure) and checked for proper function and freedom from leaks. Personnel must stay out of potential hazardous areas while testing and using.

**Routing:** The Tube Assembly should be routed in such a manner so if a failure does occur, the escaping media will not cause personal injury or property damage. In addition, if fluid media comes in contact with hot surfaces, open flame or sparks, a fire or explosion may occur. See section 2.4.

## 5.0 HOSE AND FITTING MAINTENANCE AND REPLACEMENT INSTRUCTIONS

**5.1** Even with proper selection and installation, Hose life may be significantly reduced without a continuing maintenance program. The severity of the application, risk potential from a possible Hose failure, and experience with any Hose failures in the application or in similar applications should determine the frequency of the inspection and the replacement for the Products so that Products are replaced before any failure occurs. Certain products require maintenance and inspection per industry requirements. Failure to adhere to these requirements may lead to premature failure. A maintenance program must be established and followed by the user and, at minimum, must include instructions 5.2 through 5.7.

**5.2 Visual Inspection Hose/Fitting:** Any of the following conditions require immediate shut down and replacement of the Hose Assembly:

- Fitting slippage on Hose;
- Damaged, cracked, cut or abraded cover (any reinforcement exposed);
- Hard, stiff, heat cracked, or charred Hose;
- Cracked, damaged, or badly corroded Fittings;
- Leaks at Fitting or in Hose;
- Kinked, crushed, flattened or twisted Hose; and
- Blistered, soft, degraded, or loose cover.

**5.3 Visual Inspection All Other:** The following items must be tightened, repaired, corrected or replaced as required:

- Leaking port conditions;
- Excess dirt buildup;
- Worn clamps, guards or shields; and
- System fluid level, fluid type, and any air entrapment.

**5.4 Functional Test:** Operate the system at maximum operating pressure and check for possible malfunctions and leaks. Personnel must avoid potential hazardous areas while testing and using the system. See section 2.2.

**5.5 Replacement Intervals:** Hose assemblies and elastomeric seals used on Hose Fittings and adapters will eventually age, harden, wear and deteriorate under thermal cycling and compression set. Hose Assemblies and elastomeric seals should be inspected and replaced at specific replacement intervals, based on previous service life, government or industry recommendations, or when failures could result in unacceptable downtime, damage, or injury risk. See section 1.2. Hose and Fittings may be subjected to internal mechanical and/or chemical wear from the conveying fluid and may fail without warning. The user must determine the product life under such circumstances by testing. Also see section 2.5.

**5.6 Hose Inspection and Failure:** Hydraulic power is accomplished by utilizing high pressure fluids to transfer energy and do work. Hoses, Fittings and Hose Assemblies all contribute to this by transmitting fluids at high pressures. Fluids under pressure can be dangerous and potentially lethal and, therefore, extreme caution must be exercised when working with fluids under pressure and handling the Hoses transporting the fluids. From time to time, Hose Assemblies will fail if they are not replaced at proper time intervals. Usually these failures are the result of some form of misapplication, abuse, wear or failure to perform proper maintenance. When Hoses fail, generally the high pressure fluids inside escape in a stream which may or may not be visible to the user. Under no circumstances should the user attempt to locate the leak by "feeling" with their hands or any other part of their body. High pressure fluids can and will penetrate the skin and cause severe tissue damage and possibly loss of limb. Even seemingly minor hydraulic fluid injection injuries must be treated immediately by a physician with knowledge of the tissue damaging properties of hydraulic fluid.

If a Hose failure occurs, immediately shut down the equipment and leave the area until pressure has been completely released from the Hose Assembly. Simply shutting down the hydraulic pump may or may not eliminate the pressure in the Hose Assembly. Many times check valves, etc., are employed in a system and can cause pressure to remain in a Hose Assembly even when pumps or equipment are not operating. Tiny holes in the Hose, commonly known as pinholes, can eject small, dangerously powerful but hard to see streams of hydraulic fluid. It may take several minutes or even hours for the pressure to be relieved so that the Hose Assembly may be examined safely. Once the pressure has been reduced to zero, the Hose Assembly may be taken off the equipment and examined. It must always be replaced if a failure has occurred. Never attempt to patch or repair a Hose Assembly that has failed. Consult the nearest Parker distributor or the appropriate Parker division for Hose Assembly replacement information. Never touch or examine a failed Hose Assembly unless it is obvious that the Hose no longer contains fluid under pressure. The high pressure fluid is extremely dangerous and can cause serious and potentially fatal injury.

**5.7 Elastomeric seals:** Elastomeric seals will eventually age, harden, wear and deteriorate under thermal cycling and compression set. Elastomeric seals should be inspected and replaced.

**5.8 Refrigerant gases:** Special care should be taken when working with refrigeration systems. Sudden escape of refrigerant gases can cause blindness if the escaping gases contact the eye and can cause freezing or other severe injuries if it contacts any other portion of the body.

**5.9 Compressed natural gas (CNG):** Parker CNG Hose Assemblies should be tested after installation and before use, and at least on a monthly basis per instructions provided on the Hose Assembly tag. The recommended procedure is to pressurize the Hose and check for leaks and to visually inspect the Hose for damage and to perform an electrical resistance test.

Caution: Matches, candles, open flame or other sources of ignition shall not be used for Hose inspection. Leak check solutions should be rinsed off after use.

## 6.0 HOSE STORAGE

**6.1 Age Control:** Hose and Hose Assemblies must be stored in a manner that facilitates age control and first-in and first-out usage based on manufacturing date of the Hose and Hose Assemblies. Unless otherwise specified by the manufacturer or defined by local laws and regulations:

**6.1.1** The shelf life of rubber hose in bulk form or hose made from two or more materials is 28 quarters (7 years) from the date of manufacture, with an extension of 12 quarters (3 years), if stored in accordance with ISO 2230;

**6.1.2** The shelf life of thermoplastic and polytetrafluoroethylene hose is considered to be unlimited;

**6.1.3** Hose assemblies that pass visual inspection and proof test shall not be stored for longer than 2 years.

**6.1.4 Storage:** Stored Hose and Hose Assemblies must not be subjected to damage that could reduce their expected service life and must be placed in a cool, dark and dry area with the ends capped. Stored Hose and Hose Assemblies must not be exposed to temperature extremes, ozone, oils, corrosive liquids or fumes, solvents, high humidity, rodents, insects, ultraviolet light, electromagnetic fields or radioactive materials.

# Critical Applications

## Safety

It is important to employ safe practices in the use of industrial hose due to the number of potentially dangerous applications encountered and products conveyed, and the number of people that may be involved or exposed. Strictly observe these simple practices to help avoid accidents.

- **Training:** Train all operators thoroughly
- **Evaluation:** Evaluate the application to determine the hose performance requirements
- **Selection:** Select the most appropriate hose and couplings for the application; ensure that the couplings are compatible with the media and hose, and securely attached to the hose
- **Service:** Regularly inspect and maintain both the hose and couplings while in service

While many industrial hose applications are potentially dangerous, some are of particular concern because their danger may not be readily apparent. This is especially true for applications involving untrained or inexperienced operators.

## Anhydrous Ammonia (NH<sub>3</sub>) Hose

Many accidents involving anhydrous ammonia occur due to selection of an incorrect hose for the application. Anhydrous ammonia hose must be specially designed and compounded to handle the media, with a perforated cover to prevent gas build-up amidst the layers of hose.

**WARNING!** Use ONLY anhydrous ammonia hose for anhydrous ammonia service. Contact with anhydrous ammonia in its liquid or gaseous (vapor) phase will burn skin, eyes and lungs, causing serious bodily injury or death.

- Do not use anhydrous ammonia hose for LPG service. It may fail suddenly and quickly. Anhydrous ammonia hose and LPG hose are frequently used in proximity and may be accidentally switched.
- Do not use with couplings containing o-rings, which may dry out, crack and fail over time. Do not use with male swivel couplings or other couplings containing hidden o-rings.

Anhydrous ammonia hose is designed to allow a limited amount of permeation of gas through the wall of the hose when in service, and staining of the hose cover in the pinpricked areas does not necessarily indicate leakage for a hose in service. However, a visible gas mist escaping through the hose is an indication of leakage. To verify the integrity of a hose in service, perform a hydrostatic test on the assembly; immediately remove from service any that fail the test.

**Note:** For non-agricultural or refrigeration applications, contact Parker.

## Chemical Hose

A chemical hose system failure could cause the release of poisonous, corrosive, or flammable material resulting in property damage, serious bodily injury or death. All reputable manufacturers of chemical hose recommend specific hose constructions to handle various chemicals.

Refer to the chemical guides in this catalog, or contact Parker for technical assistance before using or recommending a hose product.

### Handling

- Use care to prevent mishandling. Crushing or kinking of the hose can cause severe damage to the reinforcement.
- Use proper hose suspension equipment when lifting or dragging a hose to ensure that the recommended curvature is not exceeded. Avoid sharp bends at the end fittings and at manifold connections.

### Operation

- Use safety precautions such as wearing eye or face protection, rubber gloves, boots, and other types of protective clothing.

- Monitor pressures and temperatures to ensure that the hose is not exposed to conditions above specified limits.
- Do not allow chemicals to contact the exterior of the hose or allow hose to lie in a pool of chemicals since the hose cover may not have the same level of corrosion resistance as the tube. Corrosive materials that come into contact with the reinforcing material will cause reduced service life and premature hose failure.

### Temperature

Do not use chemical hose at pressures or temperatures exceeding those as specified for the product. Many chemical resistance guides are based on temperatures of 70°F (21°C). Elevated temperatures can change the chemical resistance ratings. Many chemicals will become more aggressive as temperatures increase, reducing the ability of hose compounds to withstand them. Contact Parker for chemical compatibility data at elevated temperatures. If no data exists, end users are required to perform compatibility testing at the desired temperature.

## Gasoline Dispenser Hose

Millions of consumers operate gasoline pumps every day, increasing the concern for the safe use of dispensing equipment, including the hose. Since gasoline dispenser hoses are subject to frequent abuse, hose selection must include consideration of the rigors of the application. For maximum service life, select only the highest quality.

**Note:** To avoid fuel contamination do not use gasoline dispenser or farm pump hose to fuel aircraft.

## LP Gas (Propane) Hose

Many accidents involving LP Gas occur due to selection of an incorrect hose for the application. LP Gas hose must be specially designed and compounded to handle the media, with a perforated cover to prevent gas build-up amidst the layers of the hose.

**WARNING!** Use ONLY LP Gas hose for LP Gas service. LP Gas possesses volatile characteristics that may produce fire or explosions causing property damage, serious bodily injury or death.

- Do not use LP Gas hose for anhydrous ammonia service. It may fail suddenly and quickly. Anhydrous ammonia hose and LPG hose are frequently used in proximity and may be accidentally switched.
- Do not use with couplings containing o-rings, which may dry out, crack and fail over time. Do not use with male swivel couplings or other couplings containing hidden o-rings.

LP Gas hose is designed to allow a limited amount of permeation of LP Gas through the wall of the hose when in service. The permeation is apparent when the hose is moist or in water, and bubbles may be perceived as leakage. However, a legitimate propane leak creates a frosting or icing on the surface of the hose or coupling.

To verify the integrity of a hose in service, perform a hydrostatic test on the assembly; immediately remove from service any hose that fails the test.

## Natural Gas and LP Gas Hose

The molecules of natural gas are small, enhancing their ability to permeate through standard rubber or PVC hose constructions. The permeation process is more rapid as the working pressure increases, and natural gas accumulates with potentially dangerous consequences.

- Use only in a well-ventilated environment: Outdoors, or indoors with significant continuous air movement.
- Do not use LP Gas hose to replace fixed/rigid pipe where that material is more appropriate due to reduced permeation, overall strength and durability. Use rigid pipe, non-permeable tubing or hose with barrier constructions to convey natural gas whenever possible.

## Petroleum Transfer Hose

- Do not use for oil or fuel transfer service in or on open water. Hose damage or failure may result in spillage and environmental damage. Use hose specifically designed for this application.
- Do not immerse in fuel. The hose cover compound may not be of sufficient grade to resist attack by the fuel. Use hose specifically designed for this application.

## Steam Hose

Water changes to hot water and phases of steam when subjected to heat and pressure. The greater the pressure, the higher the temperature required to achieve and maintain a steam phase. If steam escapes, dangerous quantities of heat may be released very suddenly.

**WARNING!** Hot water, low pressure steam and high pressure steam may escape explosively and will scald skin, eyes and lungs, which may lead to severe bodily injury or death.

- Many steam systems incorporate detergents or rust inhibitors which may attack steam hose. Prior to using a steam hose with detergents or rust inhibitors, refer to the chemical guides in this catalog, or contact Parker.
- Drain steam hose after each use to reduce the possibility of hose popcorning while in service.

The chart at the right represents the three forms of water when subjected to various combinations of heat and pressure. The red line represents the point at which hot water becomes saturated steam. The area below the red line is hot water; the area above the red line is superheated steam.

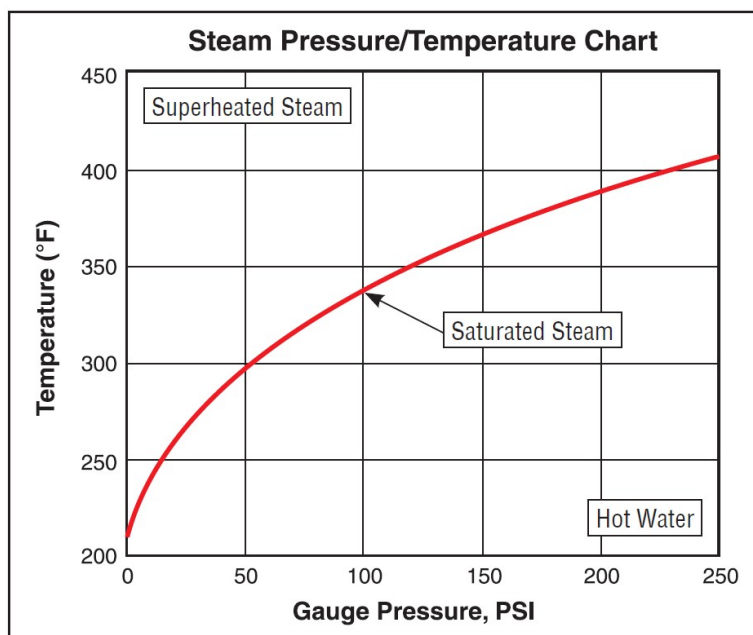

## Welding Hose

Many accidents involving welding hose occur due to selection of an incorrect hose for the application. Welding hose must be specially designed and compounded to handle the media. Due to the extreme volatility of gases, the varying compatibility of gases with the various grades of hose, and the rough environment of many welding applications, it is crucial to select the correct welding hose.

**WARNING!** Welding gases possess volatile characteristics that may produce fire or explosions causing property damage, serious bodily injury or death.

- Replace all assemblies that show signs of abrading, abuse, age, damage or fatigue. Do not attempt to recouple, repair or splice hose assemblies.
- Fabricate hose assemblies using only crimped-on ferrules at least 25 mm long to ensure coverage and support of the coupling stem inside the hose.
- Couplings attached with bands or clamps may reduce the working pressure of the hose assembly to less than the maximum rated working pressure of the hose.

## PVC / Thermoplastic Hose

Thermoplastic polymer compounds are designed to resist deterioration when exposed to a wide range of commercial chemicals and environmental conditions. The resistance to attack is based on many factors, including temperature, pressure, chemical concentration, exposure to ultraviolet light, velocity of the media and duration of exposure/ service (intermittent or constant). The user is solely responsible for making the final selection of the hose and tubing, and meeting all endurance, maintenance, performance, safety and warning requirements of the application.

**WARNING!** As temperature increases or decreases, burst pressure, safe working pressure, coupling retention properties, and other safety characteristics of the hose can significantly decrease. Failure to consider how temperature and other conditions affect hose performance may cause property damage, serious bodily injury or death.







## Oil & Fuel



ENGINEERING YOUR SUCCESS.

## A – Oil & Fuel

Hose	ID Range (mm)	Temp. Range (°C)	Application
CARBOPRESS N/L 10	5 - 25	-25 / +80	fuel, oil, petrol aromatic < 50 %
CARBURITE 10	19 - 150	-30 / +80	fuel, oil, petrol aromatic < 50 %
CARBOCORD EN 12115	19 - 63.5	-25 / +80	fuel, oil, petrol aromatic < 50 %
CHEMIOEL EN 12115	19 - 100	-25 / +80	fuel, oil, petrol aromatic < 50 %
CERVINO EN 12115	50 - 63.5	-40 / +80	fuel, oil, petrol aromatic < 50 %
E-Z FORM™ HT	12.7 - 25.4	-40 / +150	petro.-based oil suc./ret. line, power steer



	Tube	Reinforcement	Cover	WP (bar)	Design Factor	Suction	Industry standard	Page
	NBR	textile	NBR	10	3			A4
	NBR	textile	NBR/SBR	10	3	yes		A5
	NBR	textile + copper wires	NBR/SBR	16	4		EN 12115	A6
	NBR	textile + copper wires	NBR/SBR	16	4	yes	EN 12115	A7
	NBR	textile + copper wires	NBR/SBR	16	4	yes	EN 12115	A8
aring	CPE	textile	HNBR	10	4	yes		A9

# CARBOPRESS N/L 10

Suitable for fuel oils, petrol and diesel having an aromatic content not exceeded 50 % and also for grease.

## Hose Construction

- Tube:** Black, smooth, NBR rubber compound
- Reinforcement:** Synthetic textile yarns
- Cover:** Black, smooth, abrasion, oil, fuel, and weather-resistant, antistatic (R < 1 MΩ/m) special NBR rubber compound

## Temperature Range

-25 °C (-13 °F) to +80 °C (+176 °F)  
up to +100 °C (+212 °F) for oil



- Also suitable for water and air in general service applications
- Design Factor 3:1
- B100 compatible

## Tolerances

According to UNI EN ISO 1307  
Refer to Technical Handbook on page TH34

## Crimp Specifications

For currently qualified crimp specifications including coupling designation, refer to CrimpSource at [www.parker.com/crimpsource-euro](http://www.parker.com/crimpsource-euro).

Part Number			Max. Working Pressure			Weight	min. Bend Radius
	I.D. (mm)	O.D. (mm)	MPa	psi	bar	kg/m	mm
CARBOPRESS N/L 10							
IH30501001/100	5	12	1.0	150.0	10	0.12	40
IH30511003/100	6	12	1.0	150.0	10	0.11	50
IH30511002/100	6	13	1.0	150.0	10	0.14	50
IH30501002/100	8	15	1.0	150.0	10	0.17	65
IH30501003/100	10	17	1.0	150.0	10	0.20	80
IH30501004/100	13	20	1.0	150.0	10	0.24	105
IH30511004/100	16	23	1.0	150.0	10	0.29	130
IH30501006/40	19	27	1.0	150.0	10	0.39	150
IH30501007/50	25	35	1.0	150.0	10	0.63	200

Hose layline example





# CARBURITE 10

Designed for suction and delivery of mineral oils and fuels (with aromatic content not exceeding 50 %) in road and rail tankers, service stations and refineries.

## Hose Construction

**Tube:** Black, smooth, NBR rubber compound, resistant to oil and fuel with an aromatic content not exceeding 50 %

**Reinforcement:** Synthetic textile fabrics and embedded steel wire helix

**Cover:** Black, smooth, antistatic (R < 1 MΩ/m) NBR/SBR rubber compound, oil, fuel, abrasion, ageing and weather resistant

## Temperature Range

-30 °C (-22 °F) to +80 °C (+176 °F)  
up to +100 °C (+212 °F) for oil

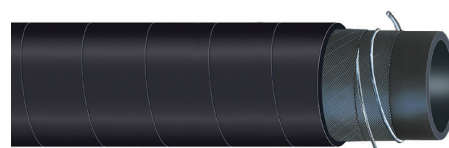

- Also suitable for water and air in general service applications
- Crimped solution with 48 series and Large Bore series
- Vacuum 0.8 bar (600 mm Hg)
- Design Factor 3:1

## Tolerances

According to RMA steel mandrel  
Refer to Technical Handbook on page TH34

## Crimp Specifications

For currently qualified crimp specifications including coupling designation, refer to CrimpSource at [www.parker.com/crimpsource-euro](http://www.parker.com/crimpsource-euro).

Part Number	I.D. (mm)	O.D. (mm)	Max. Working Pressure			Weight kg/m	min. Bend Radius mm
			MPa	psi	bar		
IH36530099/40	19	29	1.0	150.0	10	0.61	120
IH36531004/40	25	35	1.0	150.0	10	0.80	150
IH36530201/40	30	40	1.0	150.0	10	0.92	180
IH36531012/40	32	42	1.0	150.0	10	0.98	190
IH36530202/40	35	45	1.0	150.0	10	1.05	210
IH36531002/40	38	48	1.0	150.0	10	1.13	240
IH36530203/40	40	50	1.0	150.0	10	1.18	240
IH36530212/40	42	52	1.0	150.0	10	1.22	252
IH36530204/40	45	55	1.0	150.0	10	1.31	270
IH36530205/40	50	60	1.0	150.0	10	1.46	300
IH36530206/40	60	71	1.0	150.0	10	1.89	360
IH36531001/40	63.5	75,5	1.0	150.0	10	2.09	380
IH36530207/20	70	82	1.0	150.0	10	2.47	420
IH36530208/20	75	87	1.0	150.0	10	2.68	450
IH36530209/20	80	92	1.0	150.0	10	2.84	480
IH36531003/20	90	104	1.0	150.0	10	3.64	540
IH36530211/20	100	114	1.0	150.0	10	4.02	600
IH36531019/20	110	124	1.0	150.0	10	4.29	660
IH36531050/10	150	170	1.0	150.0	10	7.27	900

Hose layline example



# CARBOCORD EN 12115

According to EN 12115

*Suitable for delivery of oil and fuel with an aromatic content not exceeding 50 %.*

## Hose Construction

**Tube:** Black, smooth, NBR rubber compound, resistant to oil and fuel with an aromatic content not exceeding 50 %.

**Reinforcement:** Synthetic textile fabrics and built-in copper wires to provide electrical continuity between both ends.

**Cover:** Black, smooth, NBR/SBR rubber compound, antistatic ( $R < 1 \text{ M}\Omega/\text{m}$ ), oil, fuel, abrasion, ageing and weather resistant.

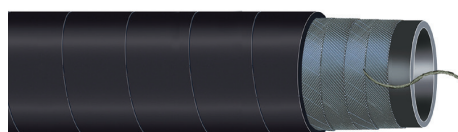

- Meets TRbF 131 Teil 2 par 5.5 (flame resistance)
- Optimal for tank truck application
- Electrical continuity guaranteed by copper wires if correctly assembled
- Design Factor 4:1

## Tolerances

According to EN 12115

Refer to Technical Handbook on page TH34

## Temperature Range

-25 °C (-13 °F) to +80 °C (+176 °F)

up to +100 °C (+212 °F) for oil

Part Number	I.D. (mm)	O.D. (mm)	Max. Working Pressure			Weight kg/m	min. Bend Radius mm
			MPa	psi	bar		
IH36522309/40	19	31	1.6	232.0	16	0.60	125
IH36522310/40	25	37	1.6	232.0	16	0.89	150
IH36522311/40	32	44	1.6	232.0	16	1.00	175
IH36522312/40	38	51	1.6	232.0	16	1.30	225
IH36522313/40	50	66	1.6	232.0	16	2.00	275
IH36522314/40	63.5	79,5	1.6	232.0	16	2.40	300

Hose layline example

CARBOCORD EN 12115 NBR 1D I.D. - PN .. - BP .. bar  $\Omega$  - TRbF 131 T2 p.5.5 - Quarter/Year



# CHEMIOEL EN 12115

According to EN 12115

*Designed for suction and delivery of mineral oils and fuels with an aromatic content not exceeding 50 %.*

## Hose Construction

**Tube:** Black, smooth, NBR rubber compound, resistant to oil and fuel with an aromatic content not exceeding 50 %

**Reinforcement:** Synthetic textile fabrics, embedded steel wire helix and built-in copper wire to facilitate the electrical connection between the hose and the end couplings

**Cover:** Black, smooth, NBR/SBR rubber compound, antistatic (R < 1 MΩ/m), oil, fuel, abrasion, ageing and weather resistant

## Temperature Range

-25 °C (-13 °F) to +80 °C (+176 °F)  
up to +100 °C (+212 °F) for oil

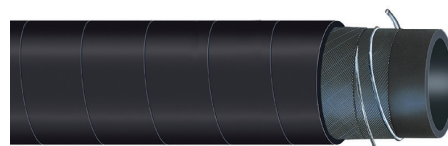

- Meets TRbF 131 Teil 2 par 5.5 (flame resistance)
- Optimal for tank truck application
- Crimped solution with 48 series and Large Bore series
- Vacuum 0.9 bar for ID up to 63.5 mm then 0.8 bar
- Design Factor 4:1

## Tolerances

According to EN 12115  
Refer to Technical Handbook on page TH34

## Crimp Specifications

For currently qualified crimp specifications including coupling designation, refer to CrimpSource at [www.parker.com/crimpsource-euro](http://www.parker.com/crimpsource-euro).

Part Number	I.D. (mm)	O.D. (mm)	Max. Working Pressure			Weight kg/m	min. Bend Radius mm
			MPa	psi	bar		
IH36530229/40	19	31	1.6	232.0	16	0.70	125
IH36530230/40	25	37	1.6	232.0	16	0.90	150
IH36530231/40	32	44	1.6	232.0	16	1.20	175
IH36530232/40	38	51	1.6	232.0	16	1.50	225
IH36530233/40	50	66	1.6	232.0	16	2.30	275
IH36530234/40	63.5	79.5	1.6	232.0	16	2.80	300
IH36530235/40	75	91	1.6	232.0	16	3.30	350
IH36530236/20	100	116	1.2	180.0	12	4.70	450

Hose layline example

CHEMIOEL EN 12115:2011 - NBR1 - SD - I.D. - WP ...bar - Ω - TRbF 131 T2p. 5.5 - Quarter/Year



# CERVINO EN 12115

According to EN 12115

*Suction and delivery of mineral oils and fuels, with an aromatic content not exceeding 50 %. The special compounds make the hose specially indicated for outdoor applications, when low temperature conditions are implicated.*

## Hose Construction

- Tube:** Black, smooth, NBR rubber compound, resistant to oil and fuel with an aromatic content not exceeding 50 %
- Reinforcement:** Synthetic textile fabrics, embedded steel wire helix and built-in copper wire to facilitate the electrical connection between the hose and the end couplings
- Cover:** Black, smooth, abrasion resistance NBR/SBR rubber compound, antistatic ( $R < 1 \text{ M}\Omega/\text{m}$ ), oil, fuel, low temperature, ageing and weather resistant

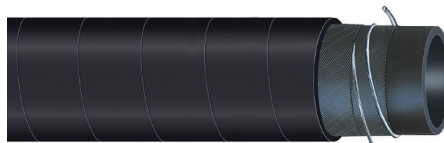

- Technology nitrogen tested for safe air applications
- Cold bend tested as per ISO 4672 without cracks
- Good result on cover abrasion test as per ISO 6945
- Crimped solution with 48 series and Large Bore series
- Vacuum 0.8 bar (600 mm Hg)
- Design Factor 4:1

## Temperature Range

-40 °C (-40 °F) to +80 °C (+176 °F) up to +100 °C (+212 °F) for oil

## Tolerances

According to EN 12115 Refer to Technical Handbook on page TH34

## Crimp Specifications

For currently qualified crimp specifications including coupling designation, refer to CrimpSource at [www.parker.com/crimpsource-euro](http://www.parker.com/crimpsource-euro).

Part Number							
	I.D. (mm)	O.D. (mm)	MPa	psi	bar	kg/m	min. Bend Radius mm
IH36530430/40	50	66	1.6	232.0	16	2.30	200
IH36530431/40	63.5	79,5	1.6	232.0	16	2.80	250

Hose layline example

CERVINO EN 12115:2011 - NBR1 - 5D - 1.0. - WP ...bar - 0 - TRbF 131 T2p. 5.5 - Quarter/Year



# E-Z FORM™ HT

Parker Global Product

*Extremely flexible, lightweight, high temperature petroleum-based oil suction/return hose designed to resist cracking and deterioration for the extreme heat generated in Tier IV engine. It may also be used in non-SAE power steering applications (as a low pressure return line only). The lightweight Greek corrugated hose construction incorporates a wire helix that provides full suction capability. The unique corrugations are tightly pitched and precision-engineered, providing extreme flexibility compared to the traditional rounded corrugation profile. The cover is resistant to high temperature oil in high temperature environments.*

## Hose Construction

**Tube:** Black CPE  
**Reinforcement:** Multiple textile braids with helix  
**Cover:** Black Hydrogenate NBR, Greek corrugated finish



- Saves time and costs thanks to easy and quick assembly
- Superior kink resistance, minimal force to bend, outstanding flexibility
- In buses, cranes, trucks and mobile/heavy duty off-road equipment
- Design Factor 4:1
- Vacuum: 0,9 bar

## Temperature Range

-40 °C (-40 °F) to +150 °C (+302 °F)

## Tolerances

According to UNI EN ISO 1307  
 Refer to Technical Handbook on page TH34

## Crimp Specifications

For currently qualified crimp specifications including coupling designation, refer to CrimpSource at [www.parker.com/crimpsource-euro](http://www.parker.com/crimpsource-euro).

Part Number							
	I.D. (mm)	O.D. (mm)	MPa	psi	bar	kg/m	min. Bend Radius mm
7399-0500025	12.7	23.8	1.0	150	10	0.43	23
7399-0625025	15.9	27.0	1.0	150	10	0.54	33
7399-0750025	19.1	30.0	1.0	150	10	0.56	36
7399-0875025	22.2	32.8	1.0	150	10	0.61	36
7399-1000025	25.4	36.0	1.0	150	10	0.66	36

coils of 7.62 m (25 feet)

Hose layline example

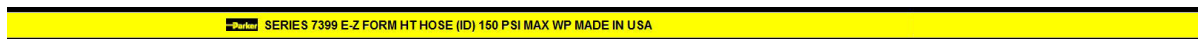



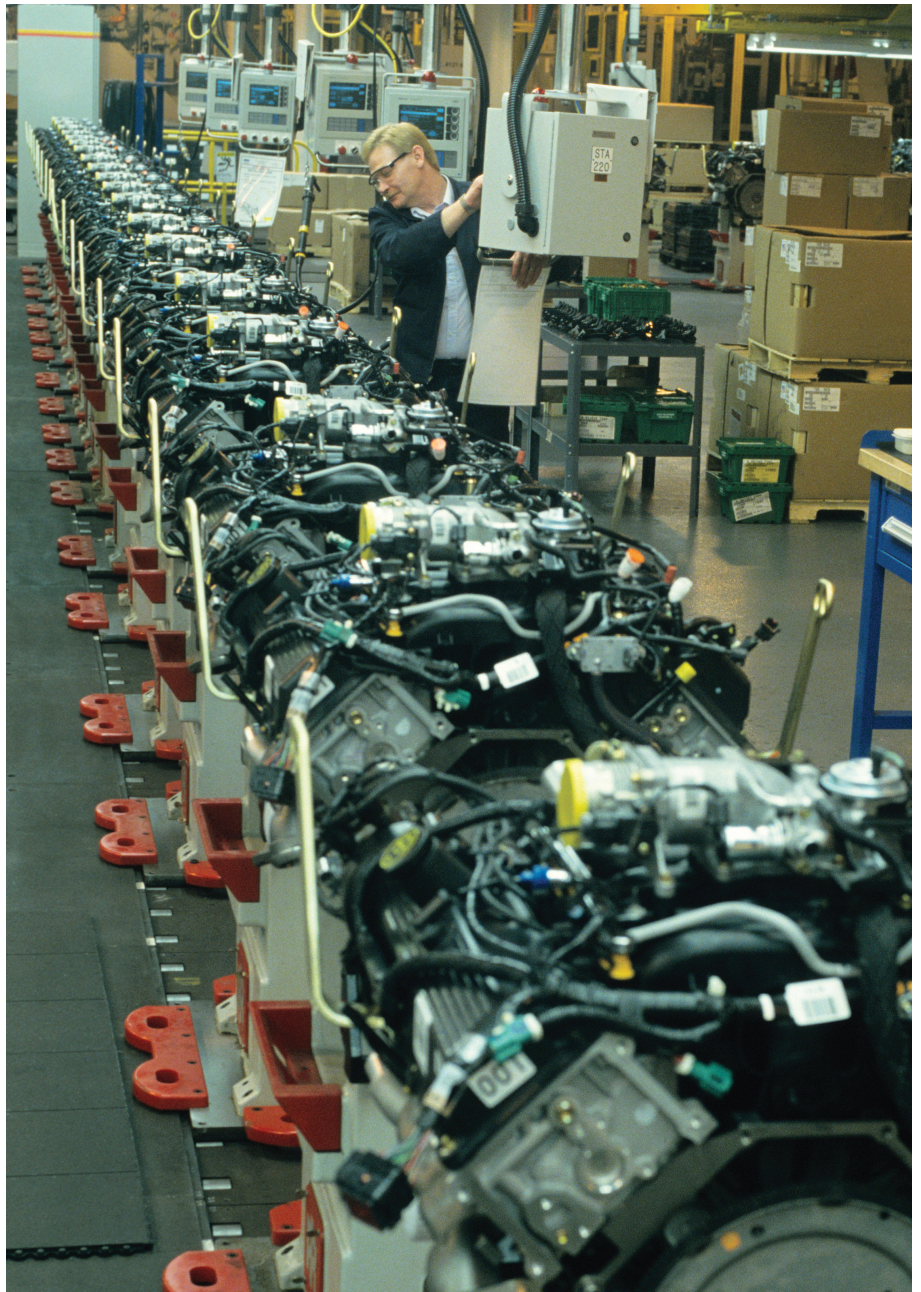

## Automotive & Boat

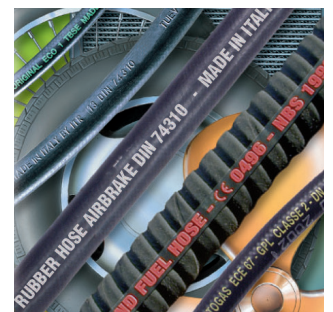

ENGINEERING YOUR SUCCESS.

## B – Automotive & Boat

Hose	ID Range (mm)	Temp. Range (°C)	Application
RADIOR 10	7 - 15	-30 / +100	cooling line system
E-Z FORM™ GS	12.7 - 102	-45 / +125	high flexible hose for coolant line system
RADIOR DIN 6	10 - 50	-40 / +125	cooling line system
Series 6722	6 - 25	-54 / +177	Heater and cooling line system
AIRBRAKE DIN 74310	9 - 13	-40 / +70	braking system
Series 395 SAE J 30R7	4.8 - 12.7	-40 / +125	car & motorbike fuel system
TBSE	4 - 10	-30 / +100	car & motorbike fuel system
TBE	3 - 7.5	-20 / +90	car & motorbike fuel system
CARBOBLUE N/L 20	6 - 25	-40 / +100	nox reducing system
WAVEMASTER™	6.3 - 19	-29 / +100	marine barrier fuel hose
SUPER-FLEX® FL-7	4.7 - 19.1	-40 / +125	low permeation fuel hose
SUPER-FLEX® FL	4.7 - 15.9	-30 / +125	low permeation fuel hose



	Tube	Reinforcement	Cover	WP (bar)	Design Factor	Suction	Industry standard	Page
	EPDM	textile	EPDM	10	3			B4
	EPDM	textile	EPDM	5	4	yes	SAE J 20R2 - D1	B5
	EPDM	textile	EPDM	6	3			B6
	SILICONE	textile	SILICONE	5.7	3		SAE J20R3 Class A	B7
	EPDM	textile	EPDM	10	4		DIN 74310	B8
	NBR	textile	CR	2.4 5.2	5		SAE 30 R7	B9
	NBR	textile	NBR	10	3			B10
	NBR	textile		10	3			B11
	EPDM	textile	EPDM	20	3			B12
	NYLON	textile	NBR/PVC	7	4	light	Refer to the page	B13
	NBR/THV	textile	CPE	6.9	5	light	SAEJ30R7/J30R14T2	B14
	NBR/ barrier	textile	CPE	6.9	5	light	AEJ30R7/J30R14T2	B15

# RADIOR 10

Flexible rubber hose for delivery of hot water in heating and cooling of automotive LPG and methane systems.

## Hose Construction

- Tube:** Black, smooth EPDM nitrosamine free rubber compound
- Reinforcement:** Synthetic textile yarns
- Cover:** Smooth, black, heat, ageing and weather-resistant EPDM nitrosamine free rubber compound

## Temperature Range

-30 °C (-22 °F) to + 100 °C (+212 °F)  
with peaks +120 °C (+248 °F)



- Specific for cooling system
- Robust structure to avoid kinking
- Design Factor 3:1

## Tolerances

According to UNI EN ISO 1307  
Refer to Technical Handbook on page TH34

## Crimp Specifications

For currently qualified crimp specifications including coupling designation, refer to CrimpSource at [www.parker.com/crimpsource-euro](http://www.parker.com/crimpsource-euro).

Part Number							
	I.D. (mm)	O.D. (mm)	MPa	psi	bar	kg/m	min. Bend Radius mm
IH30114029/100	7	13	1.0	150.0	10	0.13	50
IH30114030/100	15	23	1.0	150.0	10	0.35	90

Hose layline example





## E-Z FORM™ GS

Designed to handle air, coolant, mild chemicals and water. Extremely flexible, lightweight provides full suction capability and a path to conduct a static electrical charge to ground. The unique Greek cover corrugations provides minimal force-to-bend, superior kink resistance, and maximum flexibility for ease of handling, used where formed hose might normally be required.

### Hose Construction

- Tube:** Black EPDM, antistatic rubber compound
- Reinforcement:** Multiple textile plies with wire helix
- Cover:** Black EPDM rubber compound resistant to weathering, greek corrugated finish

### Temperature Range

-45 °C (-50 °F) to +125 °C (+257 °F)

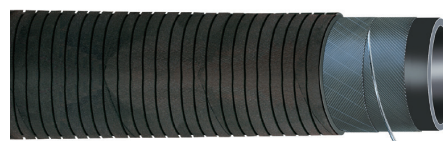

- Premium grade high temperature EPDM materials
- Saves time and costs thanks to easy and quick assembly
- Superior kink resistance, minimal force to bend, outstanding flexibility
- Performance equal to SAE J20R2-D1
- Design Factor 4:1
- Vacuum: 0.9 bar

### Tolerances

According to UNI EN ISO 1307  
Refer to Technical Handbook on page TH34

### Crimp Specifications

For currently qualified crimp specifications including coupling designation, refer to CrimpSource at [www.parker.com/crimpsource-euro](http://www.parker.com/crimpsource-euro).

Part Number	I.D. (mm)	O.D. (mm)	Max. Working Pressure			Weight kg/m	min. Bend Radius mm
			MPa	psi	bar		
IH73950500/10	12.7	23.8	1.0	150	10	0.4	23
IH73950625/10	15.9	27	1.0	150	10	0.49	33
IH73950750/10	19.1	30	1.0	150	10	0.52	36
IH73951000/10	25.4	36	1.0	150	10	0.61	36
IH73951125/10	29	38	0.5	75	5	0.62	46
IH73951250/10	32	43	0.5	75	5	0.75	56
IH73951375/10	35	46	0.5	75	5	0.79	71
IH73951500/10	38	49	0.5	75	5	0.85	74
IH73952000/10	51	63	0.5	75	5	1.44	117
IH73952250/10	57	70	0.5	75	5	1.61	165
IH73952375/10	60	73	0.5	75	5	1.64	175
IH73952500/10	63.5	76.5	0.5	75	5	1.74	183
IH73953000/10	76	90	0.5	75	5	2.23	223
IH73954000/10	102	116	0.5	75	5	3.28	340

Hose layline example



## RADIOR DIN 6 (COILS)

Designed for cooling systems of automotive engines and stationary engines and for refrigerant systems.

### Hose Construction

- Tube:** Black, smooth, antistatic, heat resistant EPDM rubber compound according to DIN 73411 - 1996\*
- Reinforcement:** Synthetic textile fabrics yarns
- Cover:** Black, smooth, wrapped finish, heat, ageing and weather-resistant EPDM rubber compound according to DIN 73411 - 1996\*

\*The tube and the cover compounds are according to DIN 73411 - 1996 in the following principal areas: tensile, strength, density, hardness, laceration, swellings, aging and dry residue.

### Temperature Range

-40 °C (-40 °F) to +125 °C (+257 °F)  
with peaks to +140 °C (+284 °F)

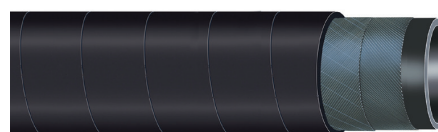

- Performances fully compliant to DIN73411
- Compounds according to DIN 73411 for: tensile, strength, density, hardness, laceration, swellings, aging and dry residue
- Specific for cooling system at high temperature
- For Automotive and general industries application
- Design Factor 3:1
- Available on request in Cut Length of 1 m

### Tolerances

I.D. ≤ 25 mm  
according to UNI EN ISO 1307

I.D. > 25 mm  
according to RMA steel mandrel

Refer to Technical Handbook on page TH34

Part Number			Max. Working Pressure			Weight	min. Bend Radius
	I.D. (mm)	O.D. (mm)	MPa	psi	bar	kg/m	mm
IH30836101/40	10	17	0.6	90.0	6.0	0.17	–
IH30836103/40	13	20	0.6	90.0	6.0	0.21	–
IH30836104/40	15	22	0.6	90.0	6.0	0.23	–
IH30836105/40	16	23	0.6	90.0	6.0	0.25	–
IH30836106/40	18	25	0.6	90.0	6.0	0.27	–
IH30836107/40	20	27	0.6	90.0	6.0	0.30	–
IH30836108/40	22	29	0.6	90.0	6.0	0.33	–
IH30836109/40	25	34	0.6	90.0	6.0	0.48	–
IH36836110/40	28	36	0.6	90.0	6.0	0.52	–
IH36836111/40	30	38	0.6	90.0	6.0	0.55	–
IH36836112/40	32	40	0.6	90.0	6.0	0.58	–
IH36836113/40	35	43	0.6	90.0	6.0	0.63	–
IH36836114/40	38	48	0.6	90.0	6.0	0.88	–
IH36836115/40	40	50	0.6	90.0	6.0	0.92	–
IH36836116/40	42	52	0.6	90.0	6.0	0.96	–
IH36836119/40	50	60	0.6	90.0	6.0	1.11	–

Hose layline example

RADIOR DIN – A – I.D. x TH – EPDM / P / EPDM – 6 bar – 125°C (yellow ink x LL and yellow embossed x MM) Y/W [with traceability code]



## SERIES 6722

Parker Global Product

*Extruded heater hose that meets or exceeds SAEJ20R3 Class A specifications. This product is utilized as standard equipment on trucks, cars and buses. Since this product is extruded it can be offered in long lengths, which saves money by reducing scrap. These hoses are resistant to coolant solutions, cracking, ozone, cold leaks, peeling and aging.*

### Hose Construction

- Tube:** Brick Red Silicone rubber compound, heat and cold resistant
- Reinforcement:** High-temperature-resistant plies
- Cover:** Blue, Silicone rubber resistant to weathering, ozone and cracking

### Temperature Range

-54 °C (-65 °F) to +177 °C (+350 °F)



- Specific for Heater and Cooling system on cars, trucks and buses
- For Automotive and general industries application
- According to SAE J20R3 Class A and SAE J2387
- Design Factor 3:1
- Peroxide curing

### Tolerances

According to UNI EN ISO 1307  
Refer to Technical Handbook on page TH34

Part Number	I.D. (mm)	O.D. (mm)	Max. Working Pressure			Weight kg/m	min. Bend Radius mm
			MPa	psi	bar		
6722-0250050	6	13	0.57	83	5.7	0.150	13
6722-0375050	10	18	0.57	83	5.7	0.196	19
6722-0500050	13	21	0.57	83	5.7	0.251	38
6722-0625050	16	24	0.57	83	5.7	0.357	44
6722-0750050	19	27	0.46	67	4.6	0.385	70
6722-1000050	25	34	0.40	58	4.0	0.506	127

coils of 15.24 m (50 feet)

Hose layline example

PARKER SILICONE SERIES 6722 -65 °F to +350 °F [DATE CODE]



# AIRBRAKE DIN 74310

According to DIN 74310  
Parker Global Product

*Widely used in automotive air brake systems.*

## Hose Construction

- Tube:** Black, smooth EPDM nitrosamine free rubber compound
- Reinforcement:** Stress-resistant, synthetic textile yarns
- Cover:** Black, abrasion, ageing and weather-resistant, smooth EPDM nitrosamine free rubber compound

## Temperature Range

-40 °C (-40 °F) to + 70 °C (+158 °F)



- Recommended DIN 74304 and DIN 74325 fittings and DIN 3017 clamps
- Automotive application
- Nitrosamine free compounds
- Design Factor 4:1



## Tolerances

According to DIN 74310  
Refer to *Technical Handbook* on page TH34

Part Number	I.D. (mm)	O.D. (mm)	Max. Working Pressure			Weight kg/m	min. Bend Radius mm
			MPa	psi	bar		
IH30315103/40	9	16	1.0	150.0	10	0.19	65
IH30315116/40	11	18	1.0	150.0	10	0.22	70
IH30315115/40	13	25	1.0	150.0	10	0.49	100

Hose layline example





## SERIES 395 SAE J30R7

Parker Global Product

Series 395 is a fuel line/vapor emission hose for refined fuels such as biodiesel (to B20 in dedicated and non-dedicated service), diesel, ethanol and gasoline. The hose is flexible for easy routing in and around small engines and small engine compartments, and the cover is resistant to abrasion, oil and weathering.

### Hose Construction

**Tube:** Black nitrile  
**Reinforcement:** Multiple textile plies  
**Cover:** Black chloroprene; smooth finish

### Temperature Range

-40 °C (-40 °F) to +125 °C (+257 °F)



- Low pressure fuel lines, vapor emission service
- B20, diesel, ethanol, gasoline
- Agricultural equipment, autos, buses, construction equipment, off-road equipment
- Design factor 5:1

### Tolerances

According to SAE J30 R7  
 Refer to Technical Handbook on page TH34

Part Number	I.D. (mm)	O.D. (mm)	Max. Working Pressure			Weight kg/m	min. Bend Radius mm
			MPa	psi	bar		
39553	4.8	10.3	0.52	75	5.2	0.100	50.8
39550	6.4	12.7	0.34	50	3.4	0.164	50.8
39551	7.9	14.3	0.34	50	3.4	0.166	76.2
39552	9.5	15.9	0.34	50	3.4	0.200	88.9
39554	12.7	19.8	0.24	35	2.4	0.260	101.6

Supplied in reels of 250 feet each (76.2 m), with max 2 lengths at least 25 feet (7.62 m) long

Hose layline example

(ID) FUEL/VAPOR LINE SAE J30R7 (DATE CODE)



B9

Catalogue 4401/UK

# TBSE

Designed for general applications in fuel systems where low permeability levels are required. Suitable for leaded and unleaded fuels and diesel.

## Hose Construction

- Tube:** Black, oil and fuel resistant, smooth, antistatic, NBR rubber compound
- Reinforcement:** Synthetic textile yarns
- Cover:** Black, oil, fuel, abrasion, weather-resistant, smooth, antistatic, NBR rubber compound



- Antistatic cover and tube compounds
- Low permeability
- Suitable for B100 and E100 up to 70 °C
- Available packaging in reels for display stand
- Design Factor 3:1

## Temperature Range

-30 °C (-22 °F) to +100 °C (+212 °F)

## Tolerances

According to UNI EN ISO 1307  
Refer to Technical Handbook on page TH34

Part Number	I.D. (mm)	O.D. (mm)	Max. Working Pressure			Weight kg/m	min. Bend Radius mm
			MPa	psi	bar		
<b>Coils</b>							
IH30871001/100	4	9	1.0	150.0	10	0.07	30
IH30871011/100	5	10	1.0	150.0	10	0.08	40
IH30871021/100	6	13	1.0	150.0	10	0.14	55
IH30871031/100	7	13	1.0	150.0	10	0.13	55
IH30871041/100	7.5	14	1.0	150.0	10	0.15	65
IH30871051/100	10	16	1.0	150.0	10	0.17	75
<b>Reels</b>							
IH30871001/15-R90*	4	9	1.0	150.0	10	0.07	30
IH30871011/15-R90*	5	10	1.0	150.0	10	0.08	40
IH30871021/15-R90*	6	13	1.0	150.0	10	0.14	55
IH30871031/15-R90*	7	13	1.0	150.0	10	0.13	55
IH30871041/15-R90*	7.5	14	1.0	150.0	10	0.15	65
IH30871051/10-R60**	10	16	1.0	150.0	10	0.17	75

\* box quantity = 6 x 15 m (reels)

\*\* box quantity = 6 x 10 m (reels)

Hose layline example

ORIGINAL ECO 1 TBSE MADE IN ITALY



B10

Catalogue 4401/UK



## TBE

*Designed for particular applications in fuel systems where textile cover is requested. Suitable for leaded and unleaded fuels and diesel.*

### Hose Construction

**Tube:** Black, oil and fuel resistant, smooth NBR rubber compound

### Reinforcement/

**Cover:** High tensile polyester textile over-braid, resistant to abrasion, fuel, oil and weathering

### Temperature Range

-20 °C (-4 °F) to +90 °C (+194 °F)

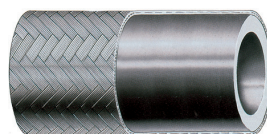

- Available in reels only
- Suitable for B20 and E100 up to 70 °C
- Designed for motorbike fuel supply
- Design Factor 3:1

### Tolerances

On inside diameter: + 0 / - 0.5 mm

Length tolerance: ± 1 %

Part Number	I.D. (mm)	O.D. (mm)	Max. Working Pressure			Weight kg/m	min. Bend Radius mm
			MPa	psi	bar		
IH11001300/15-R90*	3	7	1.0	150.0	10	0.04	30
IH11001345/15-R90*	7.5	14.5	1.0	150.0	10	0.13	65

Hose layline example

ORIGINAL TB ECO MADE IN ITALY



B11

Catalogue 4401/UK

# CARBOBLUE N/L 20

Parker Global Product

*Carboblue is specially designed for applications where there is a requirement for extracting NOx (nitrogen oxide and its mixtures that emit polluted substances into the environment during air combustion) and dramatically reducing exhaust gas from diesel engines. These objectives are included in European parameters EURO IV, EURO V and EURO VI.*

## Hose Construction

**Tube:** Black, smooth, antistatic (R < 1 MΩ/m) and sulphur free EPDM rubber compound nitrosamine free with peroxide curing.

*Extensive tests on tensile stress, cold bending, heat, and laceration resistance on compound in contact with the additive did not show alteration of its state.*

**Reinforcement:** Synthetic textile fabrics  
**Cover:** Black, smooth, antistatic (R < 1 MΩ/m), EPDM rubber compound nitrosamine free, ageing, heat and weather resistant



- Compatibility approved by Urea (AUS32) manufacturer and third part laboratory approved for ISO 22241
- Environmental friendly
- Nitrosamine free
- Design Factor 3:1



## Temperature Range

-40 °C (-40 °F) +100 °C (+212 °F) with peaks up to +120 °C (+248 °C)

## Tolerances

According to UNI EN ISO 1307  
 Refer to Technical Handbook on page TH34

## Crimp Specifications

For currently qualified crimp specifications including coupling designation, refer to CrimpSource at [www.parker.com/crimpsource-euro](http://www.parker.com/crimpsource-euro).

Part Number	I.D. (mm)	O.D. (mm)	Max. Working Pressure			Weight kg/m	min. Bend Radius mm
			MPa	psi	bar		
IH30515043/100	6	12	2.0	300.0	20	0.11	40
IH30515044/100	8	15	2.0	300.0	20	0.16	50
IH30515045/100	10	17	2.0	300.0	20	0.19	60
IH30515046/100	13	20	2.0	300.0	20	0.23	80
IH30515040/80	16	26	2.0	300.0	20	0.43	100
IH30515041/80	19	30	2.0	300.0	20	0.56	115
IH30515047/50	25	37	2.0	300.0	20	0.76	150

Hose layline example





# WAVEMASTER™

Parker Global Product

*Premium low permeation fuel tank feed and vent hose for refined fuels such as biodiesel, alcohol blended fuels, diesel, ethanol and gasoline. Specially designed for marine applications. The hose incorporates a thermoplastic barrier to resist fuel permeation and the cover is resistant to abrasion, oil and weathering.*

## Hose Construction

**Tube:** Translucent Nylon insulating  
**Reinforcement:** Multiple textile plies  
**Cover:** Black nitrile/PVC; smooth finish insulating

## Temperature Range

-29 °C (-20 °F) to +100 °C (+212 °F)

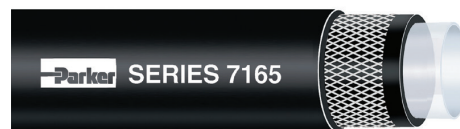

- Meets or exceeds EN ISO 7840:2013 A1, ABYC, CARB, CE, EPA, NMMA, SAE J1527 A1-15, USCG A1
- Flexible for easy routing in engine compartments
- Ideal for feed line to fuel tanks where liquid fuel is continuously in the hose under normal conditions
- Biodiesel up to B100 and E85
- Design Factor 4:1
- Vacuum: 0.35 bar

## Tolerances

According to EN ISO 7840  
 Refer to Technical Handbook on page TH34

B - Automotive & Boat

Part Number	I.D. (mm)	O.D. (mm)	Max. Working Pressure			Weight kg/m	min. Bend Radius mm
			MPa	psi	bar		
7165-25250	6.3	13.6	0.7	100	7.0	0.16	63.5
7165-31250	7.9	15.5	0.7	100	7.0	0.20	63.5
7165-38250	9.5	17.3	0.7	100	7.0	0.23	63.5
7165-50250	12.7	20.9	0.7	100	7.0	0.30	114.3
7165-63250	16.0	25.4	0.52	75	5.2	0.46	114.3
7165-75250	19.0	28.6	0.52	75	5.2	0.51	114.3

\*supplied in reels of 76.2 m (250 feet) with max 2 lengths at least 15.24 m (50 feet) long

Hose layline example

PARKER WAVEMASTER SERIES 7165 MARINE FUEL HOSE - EPA \*PKHPLINE165 - CARB RM-17-006 SAE J1527 USCG TYPE A1-15 ISO 7840 A1



B13

Catalogue 4401/UK

# SUPER-FLEX® FL-7

Parker Global Product

*Fuel line/vapor emission hose for refined fuels such as biodiesel, diesel, ethanol and gasoline. The hose incorporates a THV barrier to resist permeation, multiple aramid plies of reinforcement for coupling retention, durability and kink resistance, the cover is resistant to abrasion, oil and weathering. The hose is flexible for easy routing in and around small engines and small engine compartments. Permeation value less than 15g/m<sup>2</sup>/day.*

## Hose Construction

- Tube:** Black nitrile and translucent THV barrier, non conductive
- Reinforcement:** Multiple aramid plies
- Cover:** Black CPE, smooth finish

## Temperature Range

-40 °C (-40 °F) to +125 °C (+ 257 °F)

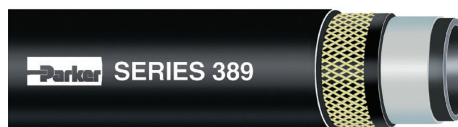

- Meets CARB 2006 SORE, EPA, SAE J30R7, SAE J30R14T2
- for blowers, grinders, mowers, offroad engines, pressure washers, saws, agricultural, buses, construction
- Biodiesel up to B20
- Design Factor 5:1
- Vacuum 0.81 bar for ID up to 9.8 mm then 0.34 bar

## Tolerances

According to UNI EN ISO 1307  
Refer to Technical Handbook on page TH34

## Crimp Specifications

For currently qualified crimp specifications including coupling designation, refer to CrimpSource at [www.parker.com/crimpsource-euro](http://www.parker.com/crimpsource-euro).

Part Number	I.D. (mm)	O.D. (mm)	Max. Working Pressure			Weight kg/m	min. Bend Radius mm
			MPa	psi	bar		
38903	4.8	10.3	0.69	100	6.9	0.10	33.0
38904	6.4	12.7	0.69	100	6.9	0.13	38.1
38905	7.9	14.3	0.69	100	6.9	0.16	50.8
38906	9.8	15.8	0.69	100	6.9	0.16	63.5
38908	12.7	19.8	0.69	100	6.9	0.26	101.6
38910	15.9	23.9	0.69	100	6.9	0.36	127.0
38912	19.1	28.6	0.69	100	6.9	0.52	152.4

Supplied in reels of 250 feet each (76.2 m), with max 2 lengths at least 25 feet (7.62 m) long

Hose layline example

**Parker** SERIES 389 SUPER-FLEX® FL-7 (ID) SAE J30R7/R14T2 FUEL LINE (x)PKHPLINE389 EPA COMPLIANT 15 g/m<sup>2</sup>/day CARB Q-08-013





# SUPER-FLEX® FL

Parker Global Product

*Fuel line/vapor emission hose for refined fuels such as diesel, ethanol and gasoline. The hose incorporates a thermoplastic barrier to resist permeation and the cover is resistant to abrasion, oil and weathering. The hose is flexible for easy routing in and around small engines and small engine compartments. Permeation value less than 15g/m<sup>2</sup>/day.*

## Hose Construction

**Tube:** Black nitrile and translucent thermoplastic barrier, non conductive

**Reinforcement:** One textile braid or multiple textile plies

**Cover:** Black CPE, smooth finish

## Temperature Range

-30 °C (-34 °F) to +125 °C (+ 257 °F)

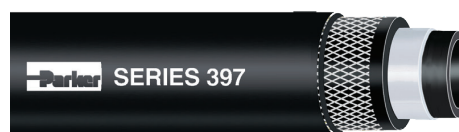

- Meets CARB 2006 SORE, EPA, SAE J30R7/J30R14T2 (Performance)
- for blowers, grinders, mowers, off-road engines, pressure washers, saws, agricultural, autos, buses
- Biodiesel up to B100
- Design Factor 5:1
- Vacuum 0.81 bar for ID up to 9.5 mm then 0.34 bar

## Tolerances

According to UNI EN ISO 1307  
Refer to Technical Handbook on page TH34

## Crimp Specifications

For currently qualified crimp specifications including coupling designation, refer to CrimpSource at [www.parker.com/crimpsource-euro](http://www.parker.com/crimpsource-euro).

Part Number	I.D. (mm)	O.D. (mm)	Max. Working Pressure			Weight kg/m	min. Bend Radius mm
			MPa	psi	bar		
39703	4.7	11.1	0.69	100	6.9	0.10	33.0
39704	6.4	12.7	0.69	100	6.9	0.13	38.1
39705	7.9	14.2	0.69	100	6.9	0.16	50.8
39706	9.5	15.9	0.69	100	6.9	0.16	63.5
39708	12.7	17.7	0.69	100	6.9	0.26	101.6
39710	15.9	23.9	0.24	35	2.4	0.33	127.0

Supplied in reels of 250 feet each (76.2 m), with max 3 lengths at least 25 feet (7.62 m) long

Hose layline example

SERIES 397 (P/N) SUPER-FLEX® FL (ID) LOW PERMEATION FUEL LINE CARB (x) PKHPLINE397 EPA COMPLIANT 15 g/m<sup>2</sup>/day C-U





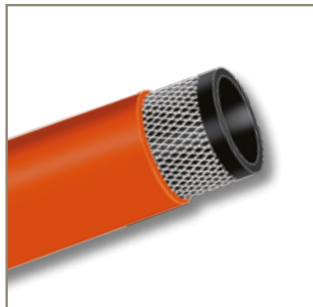

# Gas



ENGINEERING YOUR SUCCESS.

## C – Gas

Hose	ID Range (mm)	Temp. Range (°C)	Application
AUTOGENE EN ISO 3821 NR/L – NB/L 20	6.3 - 10	-25 / +80	welding process
PROPANPRESS EN ISO 3821 NA/L 20	6.3 - 10	-30 / +70	propan gas delivery



	Tube	Reinforce- ment	Cover	WP (bar)	Design Factor	Suction	Industry standard	Page
	EPDM/ SBR	textile	EPDM	20	3		EN ISO 3821	<b>C4</b>
	NBR/NR	textile	EPDM	20	3		EN ISO 3821	<b>C5</b>

# AUTOGENE EN ISO 3821 NR/L – NB/L 20

According to EN ISO 3821

*Designed for delivery of welding and allied process gases.*

## Hose Construction

**Tube:** Black, smooth EPDM rubber compound resistant to Acetylene gas (Red cover). Black, smooth EPDM/SBR rubber compound resistant to Oxygen gas (Blue cover). Not suitable for LPG, good resistance to ignition (Red and Blue)

**Reinforcement:** Synthetic textile yarns

**Cover:** Smooth and pin pricked, red (NR) or blue (NB) EPDM rubber compound resistant to abrasion, ageing hot surfaces and incandescent particles



- For welding in industrial and domestic application
- Colored cover following specs indication: Red for Acetylene and Blue for Oxygen
- Exceeds the standard on backfire test
- Excellent flexibility
- Design Factor 3:1

## Tolerances

According to EN ISO 3821  
Refer to *Technical Handbook* on page TH34

## Temperature Range

-25 °C (-13 °F) to +80 °C (+176 °F)

Part Number	I.D. (mm)	O.D. (mm)	Max. Working Pressure			Weight kg/m	min. Bend Radius mm
			MPa	psi	bar		
AUTOGENE EN ISO 3821 NR/L 20							
IH30412803/40	6.3	13.3	2.0	300.0	20	0.15	40
IH30412914/100	8	15	2.0	300.0	20	0.17	40
IH30412716/40	9	16	2.0	300.0	20	0.19	45
IH30412716/100	9	16	2.0	300.0	20	0.19	45
IH30413221/40	10	17	2.0	300.0	20	0.20	50
AUTOGENE EN ISO 3821 NB/L 20							
IH30412703/40	6.3	13.3	2.0	300.0	20	0.15	40
IH30412915/100	8	15	2.0	300.0	20	0.17	40
IH30412707/40	9	16	2.0	300.0	20	0.22	50
IH30412707/100	9	16	2.0	300.0	20	0.22	50
IH30413220/40	10	17	2.0	300.0	20	0.24	50

### IMPORTANT!

Welding applications can be hazardous. Please take all the necessary safety precautions.

Hose layline example

RUBBER HOSE – EN ISO 3821 – 2 MPa (20 bar) – I.D. (Year with traceability code)		MCXX
RUBBER HOSE – EN ISO 3821 – 2 MPa (20 bar) – I.D. (Year with traceability code)		MCXX



# PROPANPRESS EN ISO 3821 NA/L 20

According to EN ISO 3821

*Suitable for LPG in industrial applications.*

## Hose Construction

**Tube:** Black, LPG resistant smooth NBR/ NR rubber compound

**Reinforcement:** Synthetic textile yarns

**Cover:** Orange, smooth EPDM rubber compound resistant to ageing and weathering, pin-pricked cover to prevent blisters during use



- Orange cover following specs indication
- Flexible hose for easy handling
- Design Factor 3:1

## Temperature Range

-30 °C (-22 °F) to +70 °C (+158 °F)

## Tolerances

According to EN ISO 3821  
Refer to Technical Handbook on page TH34

C - Gas

Part Number	I.D. (mm)	O.D. (mm)	Max. Working Pressure			Weight kg/m	min. Bend Radius mm
			MPa	psi	bar		
IH30413456/100	6.3	13.3	2.0	300.0	20	0.16	50
IH30413457/100	8	15	2.0	300.0	20	0.18	65
IH30413459/100	8.5	16	2.0	300.0	20	0.21	70
IH30413458/100	10	17	2.0	300.0	20	0.22	80

Hose layline example

RUBBER HOSE PROPANPRESS EN ISO 3821 - 2MPa (20 bar) - I.D. (Year with the traceability code)



MCXX



C5

Catalogue 4401/UK

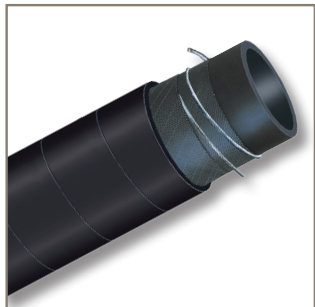
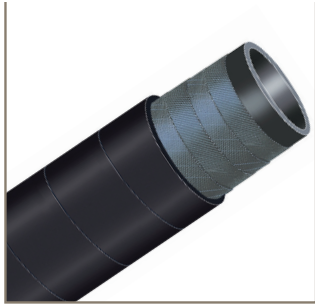

Water

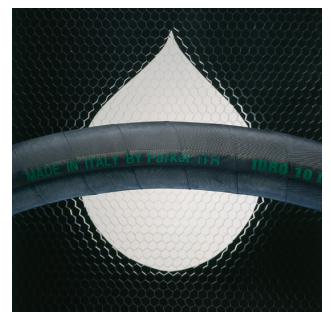

ENGINEERING YOUR SUCCESS.

## D – Water

Hose	ID Range (mm)	Temp. Range (°C)	Application
IDRO 10	25 - 60	-30 / +80	water, non aggressive liquids
BEVERA 10	19 - 125	-30 / +80	water, non aggressive liquids



	Tube	Reinforcement	Cover	WP (bar)	Design Factor	Suction	Industry standard	Page
	SBR	textile	SBR	10	3			D4
	SBR	textile	SBR	10	3	yes		D5

# IDRO 10

Suitable for discharge of water and non-aggressive liquids, for agricultural uses, also in industrial facilities and on building sites.

## Hose Construction

- Tube:** Black, smooth SBR nitrosamine free rubber compound
- Reinforcement:** Synthetic textile fabrics
- Cover:** Black: abrasion, ageing and weather-resistant SBR nitrosamine free rubber compound

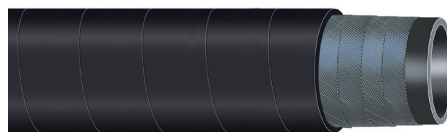

- Robust construction
- Resistant to twisting
- Nitrosamine free
- Design Factor 3:1



## Temperature Range

-30 °C (-22 °F) to +80 °C (+176 °F)

## Tolerances

According to RMA steel mandrel  
Refer to Technical Handbook on page TH34

Part Number	I.D. (mm)	O.D. (mm)	Max. Working Pressure			Weight kg/m	min. Bend Radius mm
			MPa	psi	bar		
IH36203000/40	25	34	1.0	150.0	10	0.63	250
IH36203002/40	30	41	1.0	150.0	10	0.92	300
IH36203003/40	32	44	1.0	150.0	10	1.07	320
IH36203005/40	38	52	1.0	150.0	10	1.46	380
IH36203006/40	40	54	1.0	150.0	10	1.52	400
IH36203011/40	60	82	1.0	150.0	10	3.63	600

Hose layline example





## BEVERA 10

Suction and delivery of water and non-aggressive liquids. It is recommended for loading and discharge of storage tanks, tankers, for irrigation and for all applications where a flexible and easy to handle hose is required.

### Hose Construction

- Tube:** Black, smooth SBR nitrosamine free rubber compound
- Reinforcement:** Synthetic textile fabrics and embedded steel wire helix
- Cover:** Black, abrasion, ageing and weather-resistant SBR nitrosamine free rubber compound

### Temperature Range

-30 °C (-22° F) to +80 °C (+176 °F)

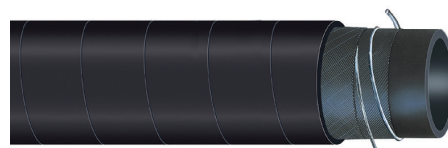

- Robust construction
- Resistant to twisting
- Nitrosamine free
- Vacuum 0.8 bar (600 mm Hg)
- Suitable for air up to 70 °C
- Design Factor 3:1



### Tolerances

According to RMA steel mandrel  
Refer to Technical Handbook on page TH34

### Crimp Specifications

For currently qualified crimp specifications including coupling designation, refer to CrimpSource at [www.parker.com/crimpsource-euro](http://www.parker.com/crimpsource-euro).

Part Number	I.D. (mm)	O.D. (mm)	Max. Working Pressure			Weight kg/m	min. Bend Radius mm
			MPa	psi	bar		
IH36214045/40	19	29	1.0	150.0	10	0.67	110
IH36214050/40	25	35	1.0	150.0	10	0.83	150
IH36214052/40	32	42	1.0	150.0	10	1.01	190
IH36214054/40	38	48	1.0	150.0	10	1.16	230
IH36214055/40	40	50	1.0	150.0	10	1.21	240
IH36214058/40	50	60	1.0	150.0	10	1.50	300
IH36214060/40	60	71	1.0	150.0	10	1.94	360
IH36214063/20	70	81.5	1.0	150.0	10	2.59	420
IH36214064/20	75	86.5	1.0	150.0	10	2.75	450
IH36214066/20	80	92.5	1.0	150.0	10	3.02	480
IH36214067/20	90	103.5	1.0	150.0	10	3.66	540
IH36214068/20	100	114	1.0	150.0	10	3.98	600
IH36211010/20	125	140	1.0	150.0	10	5.66	750

Hose layline example





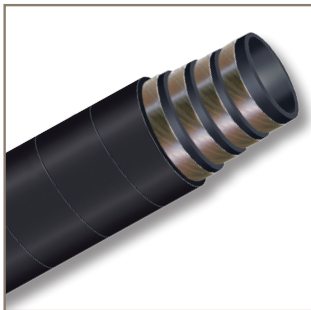

## Hot Water & Steam



ENGINEERING YOUR SUCCESS.

## E – Hot Water & Steam

Hose	ID Range (mm)	Temp. Range (°C)	Application
RADIOR 3	10 - 100	-40 / +100	cooling line system
RADIOR K 1003	12 - 50	-40 / +50	cooling line system
THERMOPRESS 10	12 - 40	-40 / +40	cooling line and hot water
VIGOR 2 EN ISO 6134 Type 2/A	13 - 51	-40 / +210	steam industrial application

### WARNING!

Steam hoses gradually decrease in performance during service life. Consequently, they need to be regularly inspected by trained personnel wearing adequate protective overalls, including eye protection. Cuts and gouges in the hose cover showing the textile reinforcement. Steam leaks. Permanent deformation of hose. Reduction of steam flow. WHEN ONE OF THESE ABNORMALITIES OCCURS, THE HOSE SHOULD BE REMOVED FROM SERVICE AND INSPECTED. If a failure occurs close to the couplings, the damaged hose can be cut, reconnected and used as before.

Use only couplings with safety clamps. Follow the coupling manufacturer's instructions for coupling procedures. Check coupling tightness each time before use. Drain after use. When not in use, store the hose on a flat surface (shelves) and never hang from a hook.



	Tube	Reinforcement	Cover	WP (bar)	Design Factor	Suction	Industry standard	Page
	EPDM	textile	EPDM	3	3			E4 - E5
	NBR	textile	CR	5	3			E6
	EPDM	textile	EPDM	10	4			E7
	EPDM	textile	EPDM	18	10		ENISO6134 Type2/A	E8

## RADIOR 3 (COIL)

Designed for cooling systems of automotive engines and stationary engines.

### Hose Construction

**Tube:** Black, smooth, heat resistant EPDM nitrosamine free rubber compound  
**Reinforcement:** Synthetic textile yarn fabric  
**Cover:** Black, smooth, heat, ageing and weather-resistant EPDM nitrosamine free rubber compound



- Light and flexible hose
- Also suitable as cable protection
- Nitrosamine free
- Design Factor 3:1



### Temperature Range

-40 °C (-40 °F) to peaks of +100 °C (+212 °F)

### Tolerances

I.D. ≤ 22 mm according to UNI EN ISO 1307  
 I.D. > 22 mm according to RMA steel mandrel  
 Refer to Technical Handbook on page TH34

Part Number							
	I.D. (mm)	O.D. (mm)	MPa	psi	bar		
IH36830095/40	10	16	0.3	43.5	3	0.16	—
IH36830096/40	12	18	0.3	43.5	3	0.19	—
IH36830097/40	15	21	0.3	43.5	3	0.23	—
IH36830101/40	18	24.5	0.3	43.5	3	0.29	—
IH36830102/40	20	26.5	0.3	43.5	3	0.32	—
IH36830103/40	22	28.5	0.3	43.5	3	0.34	—
IH36830104/40	25	32	0.3	43.5	3	0.39	—
IH36830105/40	28	36	0.3	43.5	3	0.50	—
IH36830106/40	30	38	0.3	43.5	3	0.53	—
IH36830107/40	32	40	0.3	43.5	3	0.55	—
IH36830108/40	35	43	0.3	43.5	3	0.60	—
IH36830109/40	38	47	0.3	43.5	3	0.73	—
IH36830110/40	40	49	0.3	43.5	3	0.77	—
IH36830111/40	42	51	0.3	43.5	3	0.80	—
IH36830112/40	45	54	0.3	43.5	3	0.85	—
IH36831023/40	48	57	0.3	43.5	3	0.91	—
IH36830113/40	50	60	0.3	43.5	3	1.07	—
IH36830114/40	55	65	0.3	43.5	3	1.17	—
IH36830115/40	60	70	0.3	43.5	3	1.26	—
IH36830116/20	65	76	0.3	43.5	3	1.54	—
IH36830117/20	70	81	0.3	43.5	3	1.65	—
IH36831022/20	75	86	0.3	43.5	3	1.75	—
IH36830118/20	80	92	0.3	43.5	3	2.05	—
IH36830119/20	90	102	0.3	43.5	3	2.29	—
IH36830120/20	100	113	0.3	43.5	3	2.63	—

Hose layline example





## RADIOR 3 (CUT LENGTH)

Designed for cooling systems of automotive engines and stationary engines.

### Hose Construction

**Tube:** Black, smooth, heat resistant EPDM nitrosamine free rubber compound

**Reinforcement:** Synthetic textile yarn fabric

**Cover:** Black, smooth, heat, ageing and weather-resistant EPDM nitrosamine free rubber compound

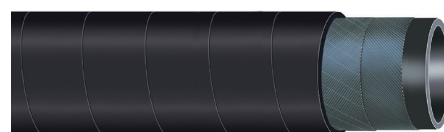

- Light and flexible hose
- In piece of 1 m length
- Straight piece without snake effect
- Nitrosamine free
- Design Factor 3:1



### Temperature Range

-40 °C (-40 °F) to peaks of +100 °C (+212 °F)

### Tolerances

I.D. ≤ 22 mm according to UNI EN ISO 1307  
 I.D. > 22 mm according to RMA steel mandrel  
 Refer to Technical Handbook on page TH34

Part Number	I.D. (mm)	O.D. (mm)	Max. Working Pressure			Weight kg/m	min. Bend Radius mm
			MPa	psi	bar		
IH36830005/1	28	36	0.3	43.5	3	0.50	–
IH36830006/1	30	38	0.3	43.5	3	0.53	–
IH36830007/1	32	40	0.3	43.5	3	0.55	–
IH36830008/1	35	43	0.3	43.5	3	0.60	–
IH36830009/1	38	47	0.3	43.5	3	0.73	–
IH36830010/1	40	49	0.3	43.5	3	0.77	–
IH36830011/1	42	51	0.3	43.5	3	0.80	–
IH36830012/1	45	54	0.3	43.5	3	0.85	–
IH36831030/1	48	57	0.3	43.5	3	0.91	–
IH36830013/1	50	60	0.3	43.5	3	1.07	–
IH36830014/1	55	65	0.3	43.5	3	1.17	–
IH36830015/1	60	70	0.3	43.5	3	1.26	–
IH36830016/1	65	76	0.3	43.5	3	1.54	–
IH36830017/1	70	81	0.3	43.5	3	1.65	–
IH36831031/1	75	86	0.3	43.5	3	1.75	–
IH36830018/1	80	92	0.3	43.5	3	2.05	–
IH36830019/1	90	102	0.3	43.5	3	2.29	–
IH36830020/1	100	113	0.3	43.5	3	2.63	–

Hose layline example



## RADIOR K 1003

Designed for heating and cooling systems, resistant to ASTM I/II/III oil up to +100 °C (+212 °F) with peaks up to +120 °C (+248 °F) and diesel fuel up to +50 °C (+122 °F).

### Hose Construction

**Tube:** Black, smooth, heat resistant NBR rubber compound  
**Reinforcement:** Synthetic textile fabrics yarns  
**Cover:** Black, smooth, wrapped finish, heat, ageing and weather-resistant CR rubber compound



- Superior Chloroprene cover compound for oil and fuel resistance paraffine
- Also suitable for B100
- Light and flexible hose
- Design Factor 3:1

### Temperature Range

-40 °C (-40 °F) to +100 °C (+212 °F)

### Tolerances

I.D. ≤ 22 mm according to UNI EN ISO 1307  
 I.D. > 22 mm according to RMA steel mandrel  
 Refer to Technical Handbook on page TH34

Part Number	I.D. (mm)	O.D. (mm)	Max. Working Pressure			Weight kg/m	min. Bend Radius mm
			MPa	psi	bar		
IH30831300/40	12	19	0.5	72.5	5	0.24	–
IH30831302/40	15	22	0.5	72.5	5	0.28	–
IH30831303/40	18	25	0.5	72.5	5	0.33	–
IH30831305/40	22	29	0.5	72.5	5	0.39	–
IH36831300/40	25	32	0.5	72.5	5	0.41	–
IH36831301/40	28	35	0.5	72.5	5	0.45	–
IH36831303/40	32	39	0.5	72.5	5	0.51	–
IH36831305/40	38	45	0.5	72.5	5	0.59	–
IH36831309/20	50	61	0.5	72.5	5	1.22	–

Hose layline example





# THERMOPRESS 10

Suitable for delivery of hot water, non-aggressive hot liquids and steam to a maximum temperature of +120 °C (+248 °F). To connect boilers to air conditioning units and for hot water cleaning systems.

## Hose Construction

- Tube:** Black, smooth, heat resistant, EPDM nitrosamine free rubber compound
- Reinforcement:** Synthetic textile fabrics or yarns
- Cover:** Black, smooth, heat, ageing and weather-resistant EPDM nitrosamine free rubber compound

## Temperature Range

-40 °C (-40 °F) to +100 °C (+212 °F), with peaks +120 °C (+248 °F)

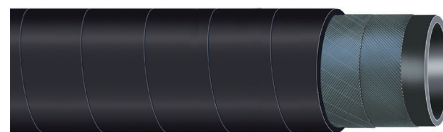

- Robust structure
- Wide temperature range
- Nitrosamine free
- Design Factor 4:1



## Tolerances

I.D. ≤ 20 mm according to UNI EN ISO 1307  
I.D. > 20 mm according to RMA steel mandrel  
Refer to Technical Handbook on page TH34

Part Number	I.D. (mm)	O.D. (mm)	Max. Working Pressure			Weight kg/m	min. Bend Radius mm
			MPa	psi	bar		
IH36800002/100	12	22.5	1.0	150.0	10	0.38	120
IH36800003/80	15	25.5	1.0	150.0	10	0.44	150
IH36800004/80	18	28.5	1.0	150.0	10	0.51	180
IH36800005/80	20	30.5	1.0	150.0	10	0.56	200
IH36800006/40	25	35	1.0	150.0	10	0.61	250
IH36800009/40	40	54	1.0	150.0	10	1.34	400

Hose layline example



## VIGOR 2 EN ISO 6134 TYPE 2/A

According to EN ISO 6134 type 2/A

*Designed for high pressure saturated steam (max 18 bar at +210 °C = 261 psi at +410 °F). Suitable for loading saturated and superheated steam in cleaning and sterilization applications, petrochemical industry and general steam service applications*

### Hose Construction

- Tube:** Black, smooth, EPDM rubber compound. Heat and saturated steam resistant
- Reinforcement:** High tensile steel cords
- Cover:** Black, smooth, EPDM rubber compound. Heat, abrasion, ozone and weather resistant.  
The cover is pinpricked to prevent blistering and bubbling.

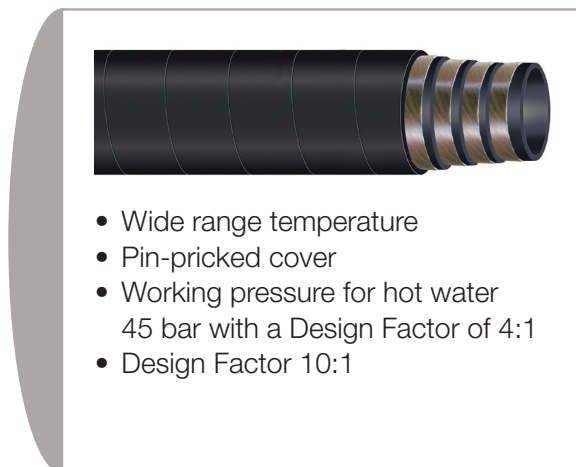

- Wide range temperature
- Pin-pricked cover
- Working pressure for hot water 45 bar with a Design Factor of 4:1
- Design Factor 10:1

### Tolerances

According to EN ISO 6134  
Refer to Technical Handbook on page TH34

### Temperature Range

-40 °C (-40 °F) to +210 °C (+410 °F)

Part Number	I.D. (mm)	O.D. (mm)	Max. Working Pressure			Weight kg/m	min. Bend Radius mm
			MPa	psi	bar		
VIGOR 2 EN ISO 6134 (black)							
IH36801700/40	13	25	1.8	261.0	18	0.50	130
IH36801701/40	16	30	1.8	261.0	18	0.70	160
IH36801702/40	19	33	1.8	261.0	18	0.77	190
IH36801703/40	25	40	1.8	261.0	18	1.06	250
IH36801704/40	32	48	1.8	261.0	18	1.39	320
IH36801705/40	38	54	1.8	261.0	18	1.60	380
IH36801706/40	51	69	1.8	261.0	18	2.56	500

Hose layline example

**WARNING!** see page E2

RUBBER HOSE VIGOR - EN ISO 6134:2005 - 2A - steam - 18 bar - 210 °C - I.D. mm - Ø - MADE IN ITALY





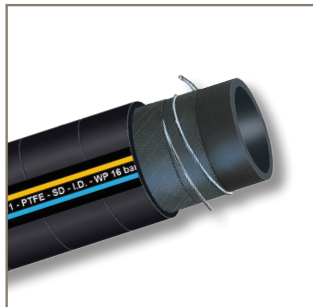

## Acid & Chemicals



ENGINEERING YOUR SUCCESS.

## F – Acid & Chemicals

Hose	ID Range (mm)	Temp. Range (°C)	Application
POLIAX D EN 12115	19 - 100	-35 / +100	chemical resistance table
POLIAX D SM EN 12115	19 - 100	-35 / +75	chemical resistance table
POLIAX UPE CON SM EN 12115	19 - 100	-20 / +100	chemical resistance table
POLIAX UPE CON SM EN 12115 OND	19 - 75	-20 / +75	chemical resistance table
POLIAX F EN 12115	13 - 75	-40 / +150	chemical resistance table
POLIAX PHARMA	13 - 51	-60 / +200	chemical resistance table

### WARNING!

If delivering chemicals over +25 °C (+77 °F), please contact us. Many chemical products can cause severe injuries to people or damage to property, and here are risks of environmental pollution in case of leakage or hose burst. All necessary measures must be taken in order to avoid accidents both during normal service operations and during hydrostatic tests, which must be carried out by trained personnel using suitable tools.



	Tube	Reinforcement	Cover	WP (bar)	Design Factor	Suction	Industry standard	Page
	EPM	textile + copper wires	EPDM	16	4		EN 12115	F4
	EPM	textile + copper wires	EPDM	16	4	yes	EN 12115	F5
	UHMWPE	textile + copper wires	EPDM	16	4	yes	EN 12115	F6
	UHMWPE	textile + copper wires	EPDM	16	4	yes	EN12115	F7
	PTFE	textile + copper wires	EPDM	16	4	yes	EN 12115	F8
	SILICONE	textile + copper wires	SILICONE	6/15	3	yes		F9

# POLIAX D EN 12115

According to EN 12115

*Suitable for delivery of highly aggressive chemicals, according to EN 12115,*

## Hose Construction

- Tube:** Black, smooth antistatic EPM nitrosamine free rubber compound
- Reinforcement:** Synthetic textile fabrics and built-in copper wires to facilitate the electrical connection between hose and end couplings
- Cover:** Black, antistatic ( $R < 1 \text{ M}\Omega/\text{m}$ ), EPDM rubber compound, heat, abrasion, ageing and weather resistant

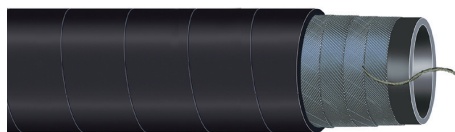

- In-plant and storage tank transfer
- Nitrosamine free
- Suitable for ATEX areas
- Meets TRbF 131 part 2 par 5.5 (flame resistance)
- Design Factor 4:1



## Tolerances

According to EN 12115  
Refer to Technical Handbook on page TH34

## Temperature Range

-35 °C (-31 °F) to +100 °C (+212 °F)

For aggressive chemicals and solvents the hose is intended to be used at room temperature. The hose can be cleaned and sterilized with usual detergents or steam – a temperature of +130 °C (+266 °F) for short periods.

Part Number			Max. Working Pressure			Weight	min. Bend Radius
	I.D. (mm)	O.D. (mm)	MPa	psi	bar	kg/m	mm
IH36810131/40	25	37	1.6	232.0	16	0.71	225
IH36810132/40	32	44	1.6	232.0	16	0.86	262.5
IH36810133/40	38	51	1.6	232.0	16	1.11	337.5
IH36810134/40	50	66	1.6	232.0	16	1.72	412.5
IH36810135/40	63.5	79,5	1.6	232.0	16	2.10	450
IH36810136/40	75	91	1.6	232.0	16	2.56	525
IH36810137/40	100	116	1.6	232.0	16	3.38	675

### WARNING!

If delivering chemicals over +25 °C (+77 °F), please contact us. Many chemical products can cause severe injuries to people or damage to property, and here are risks of environmental pollution in case of leakage or hose burst. All necessary measures must be taken in order to avoid accidents both during normal service operations and during hydrostatic tests, which must be carried out by trained personnel using suitable tools.

Hose layline example

POLIAX D EN 12115:2011 - EPDM - D - I.D. - WP ...bar - Ø - TRbF 131 T2p. 5.5 - Quarter/Year MADE IN ITALY



## POLIAX D SM EN 12115

According to EN 12115

*Suitable for suction and delivery of highly aggressive chemicals, according to EN 12115.*

### Hose Construction

- Tube:** Black, smooth antistatic EPM nitrosamine free rubber compound
- Reinforcement:** Synthetic textile fabrics, embedded steel wire helix and built-in copper wires to facilitate the electrical connection between hose and end couplings
- Cover:** Black, antistatic ( $R < 1 \text{ M}\Omega/\text{m}$ ), EPDM rubber compound, heat, abrasion, ageing and weather resistant

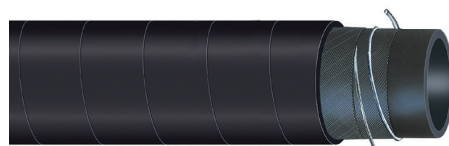

- In-plant and storage tank transfer
- Nitrosamine free
- Flexibility and kink resistance
- Suitable for ATEX areas
- Meets TRbF 131 part 2 par 5.5 (flame resistance)
- Vacuum 0.9 bar up to 63.5 mm then 0.8 bar
- Design Factor 4:1



### Tolerances

According to EN 12115  
Refer to Technical Handbook on page TH34

### Crimp Specifications

For currently qualified crimp specifications including coupling designation, refer to CrimpSource at [www.parker.com/crimpsource-euro](http://www.parker.com/crimpsource-euro).

### Temperature Range

-35 °C (-31 °F) to +100 °C (+212 °F)

For aggressive chemicals and solvents the hose is intended to be used at room temperature. The hose can be cleaned and sterilized with usual detergents or steam – a temperature of +130 °C (+266 °F) for short periods.

Part Number	I.D. (mm)	O.D. (mm)	Max. Working Pressure			Weight kg/m	min. Bend Radius mm
			MPa	psi	bar		
IH36810111/40	19	31	1.6	232.0	16	0.70	125
IH36810112/40	25	37	1.6	232.0	16	0.92	150
IH36810113/40	32	44	1.6	232.0	16	1.09	175
IH36810114/40	38	51	1.6	232.0	16	1.35	225
IH36810115/40	50	66	1.6	232.0	16	1.84	275
IH36810116/40	63.5	79.5	1.6	232.0	16	2.54	300
IH36810117/40	75	91	1.6	232.0	16	3.12	350
IH36810118/20	100	116	1.6	232.0	16	4.41	450

### WARNING!

If delivering chemicals over +25 °C (+77 °F), please contact us. Many chemical products can cause severe injuries to people or damage to property, and here are risks of environmental pollution in case of leakage or hose burst. All necessary measures must be taken in order to avoid accidents both during normal service operations and during hydrostatic tests, which must be carried out by trained personnel using suitable tools.

Hose layline example

POLIAX D EN 12115:2011 - EPDM - SD - I.D. - WP ...bar - Ø - TRbF 131 T2p. 5.5 - Quarter/Year MADE IN ITALY



# POLIAX UPE CON SM EN 12115

According to EN 12115

*POLIAX UPE CON SM EN 12115 is an heavy duty hose for suction and delivery of a wide range of highly aggressive chemicals such as most industrial acids, alkalis, oils, fuels and solvents. It can be used as a flexible connection in paint plants.*

*Refer to the Chemical Resistant Chart to determine compatibility with specific chemicals. For severe or special applications – for tighter bending radius – or if in doubt, please ask our Technical Assistance.*

## Hose Construction

- Tube:** Lucent, black, smooth, conductive, ultra high molecular weight polyethylene (UHMWPE), suitable for foodstuff contact according to FDA, EEC Directive, Italian Decrees
- Reinforcement:** Synthetic textile fabrics, embedded steel wire helix and built-in copper wires to allow the electrical connection between hose and couplings
- Cover:** Black, antistatic (R < 1 MΩ/m), EPDM rubber compound, heat, abrasion, ageing and weather resistant

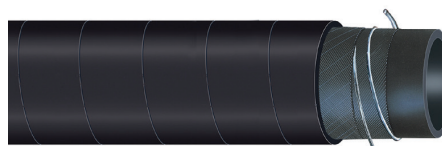

- High flexibility and kink resistance
- Fits also foodstuffs according to FDA
- Suitable for ATEX areas
- Meets TRbF 131 part 2 par 5.5 (flame resistance)
- Vacuum: 0.9 bar up to dn 63.5, 0.8 bar for larger sizes
- Design Factor 4:1

## Temperature Range

-20 °C (+5 °F) to +100 °C (+212 °F)

*For aggressive chemicals and solvents the hose is intended to be used at room temperature. The hose can be cleaned and sterilized with usual detergents or steam – a temperature of +130 °C (+266 °F) for short periods.*

## Tolerances

According to EN 12115

*Refer to Technical Handbook on page TH34*

## Crimp Specifications

For currently qualified crimp specifications including coupling designation, refer to CrimpSource at [www.parker.com/crimpsource-euro](http://www.parker.com/crimpsource-euro).

Part Number	I.D. (mm)	O.D. (mm)	Max. Working Pressure			Weight kg/m	min. Bend Radius mm
			MPa	psi	bar		
IH36811529/40	19	31	1.6	232.0	16	0.71	187.5
IH36811530/40	25	37	1.6	232.0	16	0.87	225.0
IH36811531/40	32	44	1.6	232.0	16	1.07	262.5
IH36811532/40	38	51	1.6	232.0	16	1.35	337.5
IH36811534/40	50	66	1.6	232.0	16	2.29	412.5
IH36811535/40	63.5	79,5	1.6	232.0	16	2.51	450.0
IH36811536/40	75	91	1.6	232.0	16	3.07	525.0
IH36811538/20	100	116	1.6	232.0	16	4.43	675.0

### WARNING!

If delivering chemicals over +25 °C (+77 °F), please contact us. Many chemical products can cause severe injuries to people or damage to property, and here are risks of environmental pollution in case of leakage or hose burst. All necessary measures must be taken in order to avoid accidents both during normal service operations and during hydrostatic tests, which must be carried out by trained personnel using suitable tools.

Hose layline example

POLIAX EN 12115:2011 - UPE - SD - I.D. - WP ...bar - Ω - TRbF 131 T2p. 5.5 - Quarter/Year MADE IN ITALY





# POLIAX UPE CON SM OND EN 12115

According to EN 12115

*POLIAX UPE CON SM EN 12115 OND is a very flexible hose suitable for suction and delivery of a wide range of highly aggressive chemicals such as most industrial acids, alkalis, oils, fuels and solvents. It can also be used as a flexible connections in paint plants.*

*Refer to the Chemical Resistant Chart to determine compatibility with specific chemicals. For severe or special applications – for tighter bending radius – or if in doubt, please ask our Technical Assistance.*

## Hose Construction

- Tube:** Lucent, black, smooth, conductive, ultra high molecular weight polyethylene (UHMWPE), suitable for foodstuff contact according to FDA, EEC Directive, Italian Decrees
- Reinforcement:** Synthetic textile fabrics, embedded steel wire helix and built-in copper wires to allow the electrical connection between hose and couplings
- Cover:** Black, corrugated, antistatic ( $R < 1 \text{ M}\Omega/\text{m}$ ), EPDM rubber compound, heat, abrasion, ageing and weather resistant



- Extreme flexibility, superior kink resistance, minimal force to bend
- Fits also foodstuffs according to FDA
- Suitable for ATEX areas
- Meets TRbF 131 part 2 par 5.5 (flame resistance)
- Vacuum: 0.9 bar up to dn 63.5, for larger sizes 0.8 bar
- Design Factor 4:1

## Temperature Range

-20 °C (+5 °F) to +100 °C (+212 °F)

*For aggressive chemicals and solvents the hose is intended to be used at room temperature. The hose can be cleaned and sterilized with usual detergents or steam – a temperature of +130 °C (+266 °F) for short periods.*

## Tolerances

According to EN 12115

*Refer to Technical Handbook on page TH34*

Part Number	I.D. (mm)	O.D. (mm)	Max. Working Pressure			Weight kg/m	min. Bend Radius mm
			MPa	psi	bar		
IH36811570/40	19	31	1.6	232.0	16	0.71	38
IH36811571/40	25	37	1.6	232.0	16	0.87	50
IH36811572/40	32	44	1.6	232.0	16	1.07	64
IH36811573/40	38	51	1.6	232.0	16	1.35	76
IH36811574/40	50	66	1.6	232.0	16	2.29	100
IH36811575/40	63.5	79,5	1.6	232.0	16	2.51	127
IH36811576/40	75	91	1.6	232.0	16	3.07	150

### WARNING!

If delivering chemicals over +25 °C (+77 °F), please contact us. Many chemical products can cause severe injuries to people or damage to property, and here are risks of environmental pollution in case of leakage or hose burst. All necessary measures must be taken in order to avoid accidents both during normal service operations and during hydrostatic tests, which must be carried out by trained personnel using suitable tools.

Hose layline example

POLIAX EN 12115:2011 - UPE - SD - I.D. - WP ...bar - Ω - TRbF 131 T2p. 5.5 - Quarter/Year MADE IN ITALY



# POLIAX F EN 12115

According to EN 12115

*POLIAX F EN 12115 is manufactured with high quality elastomers, with excellent chemical and mechanical properties, it results suitable for suction and delivery of a wide range of highly aggressive chemicals and solvents. Hose resistant to high temperature and designed for heavy chemical, foodstuff, pharmaceutical and cosmetic industry. Full conductive hose type  $\Omega/T$  according to EN 12115,  $R < 1M\Omega$  and  $R < 1G\Omega$  through the wall. Suitable also for ATEX area.*

*Not to be used with chlorine tri-fluoride, chlorine and fluorine gas, oxygen di-fluoride, phosgene and molten alkalis (e.g., sodium).*

## Hose Construction

**Tube:** Black, smooth, phthalates free PTFE (poly-tetrafluoroethylene). Superior resistance to high temperature, mechanical stress and to oxidation.

**Reinforcement:** High temperature resistant plies, galvanized helix wire and copper wires to discharge electricity.

**Cover:** Black, smooth, conducting ( $R < 1 M \Omega/m$ ) EPDM rubber compound, ageing, ozone and abrasion resistant.

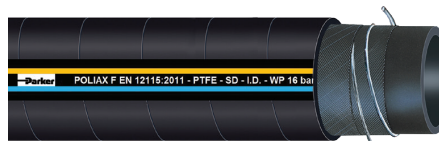

- High flexibility and kink resistance
- Fits also foodstuffs according to FDA
- Suitable for ATEX areas zone 0, 1 and 2
- Meets TRbF 131 part 2 par 5.5 (flame resistance)
- Meets USP XXXII class VI requirements
- Vacuum: 0.9 bar
- Design Factor 4:1

## Temperature Range

-40 °C (-40 °F) to +150 °C (+302 °F)

*For aggressive chemical and solvents intended to be used at high temperature please contact our Technical Assistance. For cleaning & sterilization refer to "Guidelines to the Use and Cleaning of Food and Pharma rubber hoses".*

## Tolerances

According to EN 12115

Refer to Technical Handbook on page TH34

Part Number	I.D. (mm)	O.D. (mm)	Max. Working Pressure			Weight kg/m	min. Bend Radius mm
			MPa	psi	bar		
IH36811541/0	13	25	1.6	232	16	0.54	90
IH36811542/0	19	31	1.6	232	16	0.70	130
IH36811543/0	25	37	1.6	232	16	0.86	170
IH36811544/0	32	44	1.6	232	16	1.18	215
IH36811545/0	38	51	1.6	232	16	1.43	255
IH36811546/0	50	66	1.6	232	16	2.08	330
IH36811547/0	63.5	79.5	1.6	232	16	2.96	430
IH36811548/0	75	91	1.6	232	16	3.43	510

### WARNING!

If delivering chemicals over +25 °C (+77 °F), please contact us. Many chemical products can cause severe injuries to people or damage to property, and here are risks of environmental pollution in case of leakage or hose burst.

All necessary measures must be taken in order to avoid accidents both during normal service operations and during hydrostatic tests, which must be carried out by trained personnel using suitable tools.

Hose layline example





# POLIAX PHARMA

Flexible hose suitable for suction and delivery of pharmaceutical and cosmetic products and also suitable for food transfer. Not intended for use as an implant material. This silicone hose shows a Platinum-catalyzed cure system.

*Not suitable for blood or human fluids.*

## Hose Construction

- Tube:** Translucent, smooth, phthalates free, SILICONE rubber compound insulating.
- Reinforcement:** High temperature resistant plies and stainless steel wire helix
- Cover:** Translucent, smooth, SILICONE rubber compound insulating, heat, ageing, ozone and abrasion resistant.

## Temperature Range

-60 °C (-76 °F) to +200 °C (+392 °F)

*For aggressive chemicals and solvents intended to be used at high temperature please contact our Technical Assistance. For cleaning & sterilization refer to "Guidelines to the Use and Cleaning of Food and Pharma rubber hoses"*

## Tolerances

According to UNI EN ISO 1307

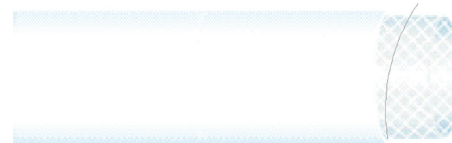

- High Flexibility and kink resistance
- Meets European Pharmacopoeia 3.1.9 Ed. VII 2011
- 3A Sanitary Standard Class II
- Japan Ministry of Health and Welfare Notice No.370,1959, No.201,2006 and revision 2012
- USP XXXII class VI requirements
- ISO 10993 Sections 5,10,11:2009
- FDA CFR 21 PART 177.2600
- DM 21/03/1973
- BfR Reccomandation XV & XXI Cat. 2
- European Reglement 1935/2004/CE
- Tested in compliance with 907/2006/CE (REACH)
- Vacuum: 0.9 bar
- Design Factor 3:1

F - Acid & Chemicals

Part Number	I.D. (mm)	O.D. (mm)	Max. Working Pressure			Weight kg/m	min. Bend Radius mm
			MPa	psi	bar		
IH36811580/0	13	24	1.5	225	15	0.46	60
IH36811581/0	16	27	1.4	210	14	0.53	70
IH36811582/0	19	30	1.3	195	13	0.6	80
IH36811583/0	25	36	1.0	150	10	0.73	100
IH36811584/0	32	43	0.8	120	8	0.89	130
IH36811585/0	38	51	0.7	105	7	1.21	155
IH36811586/0	51	64	0.6	90	6	1.56	210

### WARNING!

If delivering chemicals over +25 °C (+77 °F), please contact us. Many chemical products can cause severe injuries to people or damage to property, and here are risks of environmental pollution in case of leakage or hose burst.

All necessary measures must be taken in order to avoid accidents both during normal service operations and during hydrostatic tests, which must be carried out by trained personnel using suitable tools.

Hose layline example



F9

Catalogue 4401/UK



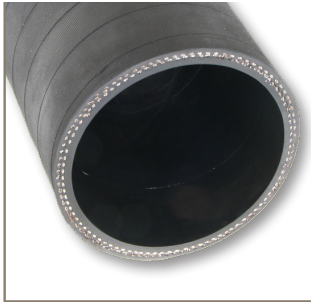

## Material Handling



ENGINEERING YOUR SUCCESS.

## G – Material Handling

Hose	ID Range (mm)	Temp. Range (°C)	Application
LIBECCIO EN ISO 3861	19 - 80	-30 / +70	wet and dry sand and cement
BETON 80	51 - 125	-40 / +70	high pressure concrete pumping
CERGOM	25 - 200	-30 / +70	high abrasive materials
ASPIREX	20 - 100	-15 / +60	suction equipment



	Tube	Reinforcement	Cover	WP (bar)	Design Factor	Suction	Industry standard	Page
	BR/NR	textile	SBR/NBR	10	4		EN ISO 3861	G4
	NR/SBR	steel wire	NR/SBR	80	2.5			G5
	CERAMIC	textile + copper wires	SBR/NBR	6	3	yes		G6
	PVC	PVC wire	PVC	-	-	yes		G7

# LIBECCIO EN ISO 3861

According to EN ISO 3861

*Suitable for conveying of wet and dry sand and grit blasting materials.*

## Hose Construction

**Tube:** Smooth, black, antistatic, abrasion resistant BR/NR rubber compound. Abrasion according to ISO 4649: max. 60 - 70 mm<sup>3</sup>

**Reinforcement:** Synthetic textile fabrics

**Cover:** Black, smooth, antistatic, weather and abrasion resistant SBR/NBR compound. The cover is pinpricked to prevent blistering and bubbling, max. resistance on finished hose: 2,0 MΩ/m



- Robust and light version available
- Construction, general industry, shipyards
- Design Factor 4:1

## Tolerances

According to RMA steel mandrel  
Refer to Technical Handbook on page TH34

## Temperature Range

-30 °C (-22 °F) to +70 °C (+158 °F)

Part Number	I.D. (mm)	O.D. (mm)	Max. Working Pressure			Weight kg/m	min. Bend Radius mm
			MPa	psi	bar		
IH36820300/40	19	33	1.0	150.0	10	0.69	190
IH36820200/40	25	40	1.0	150.0	10	0.92	250
IH36820201/40	30	45	1.0	150.0	10	1.05	300
IH36820202/40	32	48	1.0	150.0	10	1.37	320
IH36820303/40	38	55	1.0	150.0	10	1.46	380
IH36820206/40	50	72	1.0	150.0	10	2.54	500
IH36820207/40	60	82	1.0	150.0	10	2.95	600
IH36820209/20	80	105	1.0	150.0	10	4.32	800

Hose layline example

RUBBER HOSE LIBECCIO EN ISO 3861 ID mm – WP 1,0 MPa – ABRASION 60/70 mm<sup>3</sup>





## BETON 80

Suitable for placement of concrete at casting locations by concrete pumps at the ends of the machine arms.

### Hose Construction

- Tube:** Smooth, black NR/SBR compound resistant to the abrasive action of the concrete abrasion DIN 53516: max. 50±5 mm<sup>3</sup>
- Reinforcement:** Steel wire cord plies
- Cover:** Black, smooth, weather and abrasion resistant NR/SBR rubber compound

### Temperature Range

-40 °C (-40 °F) to +70 °C (+158 °F)



- Flexibility and kink resistance also for easy cleaning
- Wet abrasive materials
- High abrasion resistant tube assures longer service life
- Dedicated fitting series
- Design Factor 2.5:1

### Tolerances

On outside diameter  
According to RMA steel mandrel

On inside diameter  
According to UNI EN ISO 1307  
Refer to Technical Handbook on page TH34

Part Number	I.D. (mm)	O.D. (mm)	Max. Working Pressure			Weight kg/m	min. Bend Radius mm
			MPa	psi	bar		
IH36827051/0	51	75	8	1200	80	3.96	380
IH36827052/0	65	89	8	1200	80	4.84	400
IH36827053/0	76	100	8	1200	80	5.4	400
IH36827054/0	100	124	8	1200	80	7.04	550
IH36827055/0	125	150	8	1200	80	8.9	700

Hose layline example



# CERGOM

Parker Global Product

*Suitable for pneumatic suction and delivery of dry cement, coal, CDR (fuel by-waste material), minerals, ceramic powder, glass recovery, fibreglass, and to load tankers and storage bins or silos. Applications in the industries: steelworks, cookery, thermoelectric power plant, cement works, mining industries, ceramic works, glassworks, insulating material manufactures etc. Supplied in customized lengths.*

## Hose Construction

**Tube:** Ceramic hexagonal plates (sinterized Alumina Oxide) processed to match black BR/NR rubber compound, highly resistant to abrasion

**Reinforcement:** Synthetic textile fabrics, embedded steel wire helix and built-in copper wires to provide electrical continuity between both ends

**Cover:** Black, antistatic (R < 2.0 MΩ/m), abrasion and weather-resistant, SBR/NBR rubber compound

## Temperature Range

-30 °C (-22 °F) to +70 °C (+158 °F)

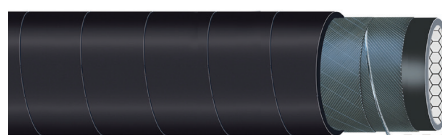

- Parker International Patent PCT-EP2007-057488
- Outstanding resistance at the abrasion
- Unique construction provides service life many times longer than traditional rubber hoses
- Reduces operations, logistics and admin costs
- Customized assemblies with built-in tech
- Design Factor 3:1

## Tolerances

Length tolerance ± 1 %

## Fittings

DIN 2817 PN 16 built-in (max length hose: from I.D. 42 to 125 mm = 20 m; other diameters = 10 m)

Part Number							
	I.D. (mm)	O.D. (mm)	MPa	psi	bar		
IH36829020/0	25	49	1.0	145.0	10	2.59	375
IH36829021/0	32	56	1.0	145.0	10	3.07	480
IH36829022/0	38	62	1.0	145.0	10	3.48	570
IH36829023/0	42	66	1.0	145.0	10	3.75	630
IH36829024/0	48	72	1.0	145.0	10	4.17	720
IH36829025/0	50	74	1.0	145.0	10	4.31	750
IH36829026/0	60	86	1.0	145.0	10	5.27	900
IH36829027/0	63.5	90	1.0	145.0	10	5.54	953
IH36829028/0	70	100	1.0	145.0	10	6.00	1050
IH36829029/0	75	105	1.0	145.0	10	6.35	1125
IH36829030/0	80	110	1.0	145.0	10	6.93	1200
IH36829031/0	100	132	1.0	145.0	10	8.56	1500
IH36829032/0	114	147	1.0	145.0	10	13.24	1710
IH36829033/0	125	158	1.0	145.0	10	14.42	1875
IH36829034/0	150	188	1.0	145.0	10	19.42	2250
IH36829035/0	200	240	1.0	145.0	10	27.68	3045

Hose layline example





## ASPIREX

Suitable for suction of air, dust, fumes, saw-dust and wood-shavings. Also suitable for centralized suction equipment in wood, textile, china and welding equipment. It is also suitable for use on agricultural machinery.

### Hose Construction

Flexible hose having a grey, rigid PVC spiral embedded in a metalized grey, flexible PVC wall. Externally corrugated, smooth inner surface. Self-extinguishing.

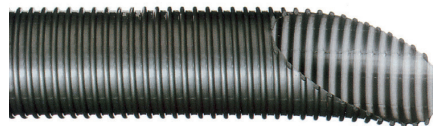

- Self-extinguishing hose
- According to UL 94 V-2
- General purpose hose
- Not to be used under pressure
- Vacuum 0.75 bar for ID up to 50 mm then 0.40 bar

### Temperature Range

-15 °C (+5 °F) to +60 °C (+140 °F)

### Tolerances

Refer to Technical Handbook on page TH34

Part Number	I.D. (mm)	Wall (mm)	Max. Working Pressure			Weight kg/m	min. Bend Radius mm
			MPa	psi	bar		
IH35560020/50	20	2.6	–	–	–	0.14	20
IH35560025/50	25	2.9	–	–	–	0.18	25
IH35560040/50	40	3.9	–	–	–	0.36	40
IH35560050/50	50	4.2	–	–	–	0.52	50
IH35560060/50	60	4.4	–	–	–	0.64	60
IH35560070/50	70	4.8	–	–	–	0.76	70
IH35560080/50	80	5.0	–	–	–	0.97	80
IH35560100/30	100	5.3	–	–	–	1.27	100

Hose layline example

ASPIREX I.D. mm - SELF-EXTINGUISHING PARKER





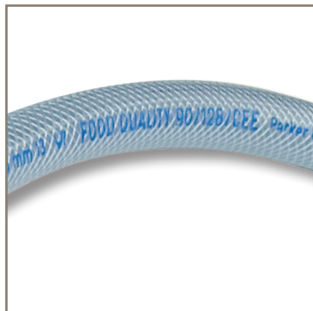
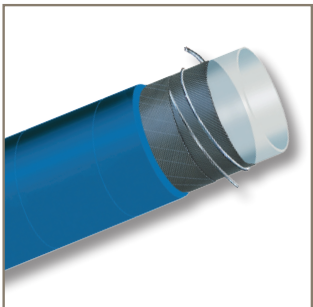

## Beverage & Food



ENGINEERING YOUR SUCCESS.

## H – Beverage & Food

Hose	ID Range (mm)	Temp. Range (°C)	Application
DRINKPRESS WB/L 10	10 - 25	-30 / +110	food & beverage, wash-down
GAMBRINUS UPE SM EN12115	19 - 100	-20 / +100	food & beverage
GAMBRINUS BLUE 10	19 - 80	-30 / +80	fatty food & beverage
GAMBRINUS BLUE SM 10	19 - 102	-30 / +80	fatty food & beverage
GAMBRINUS RED SM 10	19 - 102	-40 / +120	wine and soft drinks food & beverage
VINITRESS	6 - 40	-20 / +60	food & beverage
APERSPIR	12 - 150	-10 / +60	food & beverage

## Guidelines to the use and cleaning of food rubber hose

Refer to Technical Handbook on page TH13



	Tube	Reinforcement	Cover	WP (bar)	Design Factor	Suction	Industry standard	Page
	NBR	textile	NBR/PVC	10	4		FDA - EC	H4
	UHMWPE	textile + copper wires	EPDM	16	4	yes	**EN12115-FDA-DM	H5
	NBR	textile	NBR/PVC	10	3		* BfR - DM - FDA - EC	H6
	NBR	textile	NBR/PVC	10	3	yes	* BfR - DM - FDA - EC	H7
	EPDM	textile	EPDM	10	3	yes	* BfR - DM - FDA - EC	H8
	PVC	textile	PVC	20	3		EC 90/128 CLASS A-B-C	H9
	PVC	steel wire	PVC	15	3	yes	EC 90/128 CLASS A-B-C	H10

\* BfR Class2 - DM 21/03/73 - FDA title21 - EC 1935/2004

\*\* EN 12115 - FDA title21 - DM 21/03/73 - DM 220 26/04/93

## DRINKPRESS WB/L 10

Designed for delivery of all foodstuffs containing vegetable fats and fluids as well as beverages such as wine, fruit juices and liqueurs. Also suitable for wash-down in food processing with hot water.

### Hose Construction

**Tube:** White, smooth, NBR food quality rubber compound  
**Reinforcement:** High tensile synthetic yarns  
**Cover:** Blue, smooth, abrasion, vegetable fats, ozone and weather resistant NBR/PVC rubber compound

### Temperature Range

-30 °C (-22 °F) to +110 °C (+230 °)



- Multipurpose food grade hose
- According to FDA 21 – EC 1935/2004
- Versatility of use, food transfer, wash-down applications
- Design Factor 3:1

### Tolerances

According to UNI EN ISO 1307/97  
Refer to Technical Handbook on page TH34

### Crimp Specifications

For currently qualified crimp specifications including coupling designation, refer to CrimpSource at [www.parker.com/crimpsource-euro](http://www.parker.com/crimpsource-euro).

Part Number			Max. Working Pressure			Weight	min. Bend Radius
	I.D. (mm)	O.D. (mm)	MPa	psi	bar	kg/m	mm
IH30240022/40	10	19	1	150	10	0.31	80
IH30240020/40	13	23	1	150	10	0.42	105
IH30240025/40	16	26	1	150	10	0.49	130
IH30240030/40	19	30	1	150	10	0.71	150
IH30240035/40	25	36	1	150	10	1.05	200

Hose layline example

RUBBER HOSE DRINKPRESS FDA **Parker** MADE IN ITALY MCXX



H4

Catalogue 4401/UK



## GAMBRINUS UPE SM EN 12115

According to EN 12115

*Designed to handle all beverages such milk, mineral water, fruit juices, wine, liqueurs etc., as well as animal or vegetable fats and oils. It is also suitable for sanitary materials. UHMWPE tube does not leach into and contaminate the product conveyed. Suitable for suction and delivery.*

### Hose Construction

- Tube:** Smooth, white undercoat, ultra high molecular weight translucent polyethylene (UHMWPE), suitable for foodstuff contact
- Reinforcement:** Synthetic textile fabrics with embedded steel wire helix and copper wire to allow electrical connection between hose and couplings
- Cover:** Blue, abrasion and weather resistant EPDM rubber compound



- According to EN 12115 - FDA title21 - DM 21/03/73 - DM 220 26/04/93
- Compatibility with all liquid foodstuffs & outstanding performance in one solution
- Design Factor 4:1
- Vacuum: 0.8 bar max

### Tolerances

According to EN 12115  
Refer to Technical Handbook on page TH34

H - Beverage & Food

### Temperature Range

-20 °C (-4 °F) to +100 °C (+212 °F)  
sterilization at 130 °C for short periods

Part Number	I.D. (mm)	O.D. (mm)	Max. Working Pressure			Weight kg/m	min. Bend Radius mm
			MPa	psi	bar		
IH36242301/40	19	31	1.6	232.0	16	0.70	190
IH36242302/40	25	37	1.6	232.0	16	0.90	225
IH36242303/40	32	44	1.6	232.0	16	1.20	260
IH36242304/40	38	51	1.6	232.0	16	1.50	335
IH36242305/40	50	66	1.6	232.0	16	2.20	410
IH36242306/40	63.5	79,5	1.6	232.0	16	2.80	450
IH36242307/40	75	91	1.6	232.0	16	3.30	525
IH36242309/40	100	116	1.2	180.0	12	4.70	675

Hose layline example

GAMBRINUS UPE SD - I.D. - WP ...bar - M - FDA - D.M. 21/03/73 EN12115:2011 MADE IN ITALY



H5

Catalogue 4401/UK

# GAMBRINUS BLUE 10

Designed to handle fatty foods, milk in a variety of transfer and delivery applications, including milk collection.

## Hose Construction

**Tube:** White, smooth NBR Phthalates free rubber compound, non-toxic, odorless and taste-free. Manufactured on stainless steel mandrel for the maximum cleanliness, hygienic standards and a bacteria-free surface.

**Reinforcement:** Synthetic textile fabrics  
**Cover:** Blue NBR/PVC rubber compound, non-marking, abrasion and weather-resistant

## Temperature Range

-30 °C (-22 °F) to +80 °C (+176 °F)  
 sterilization at 110 °C for max 10 min.



- According to FDA, BfR class 2, DM 21/03/73, EC 1935/2004
- Indoors and outdoors
- ADI free
- Design Factor 3:1

## Tolerances

According to RMA steel mandrel  
 Refer to Technical Handbook on page TH34

## Crimp Specifications

For currently qualified crimp specifications including coupling designation, refer to CrimpSource at [www.parker.com/crimpsource-euro](http://www.parker.com/crimpsource-euro).

Part Number				Max. Working Pressure				
	I.D. (mm)	O.D. (mm)		MPa	psi	bar		
IH36242431/40	19	29	1.0	150.0	10	0.67	120	
IH36242432/40	25	36	1.0	150.0	10	0.80	150	
IH36242434/40	32	44	1.0	150.0	10	1.23	190	
IH36242435/40	38	50	1.0	150.0	10	1.38	240	
IH36242436/40	40	52	1.0	150.0	10	1.41	250	
IH36242437/40	45	57	1.0	150.0	10	1.62	310	
IH36242438/40	51	64	1.0	150.0	10	1.88	350	
IH36242439/40	60	73	1.0	150.0	10	2.24	410	
IH36242441/40	70	83	1.0	150.0	10	2.86	550	
IH36242443/40	80	93	1.0	150.0	10	3.17	630	

Hose layline example



H6

Catalogue 4401/UK



## GAMBRINUS BLUE 10 SM

Designed to handle fatty foods, milk in a variety of suction and delivery applications indoors and outdoors, including milk collection.

### Hose Construction

**Tube:** White, smooth NBR Phthalates free rubber compound, non-toxic, odorless and taste-free. Manufactured on stainless steel mandrel for the maximum cleanliness, hygienic standards and a bacteria-free surface.

**Reinforcement:** Synthetic textile fabrics and embedded steel wire helix

**Cover:** Blue NBR/PVC rubber compound, non-marking, abrasion and weather-resistant.

### Temperature Range

-30 °C (-22 °F) to +80 °C (+176 °F)  
sterilization at 110 °C for max 10 min.



- According to FDA, BfR class 2, DM 21/03/73, EC 1935/2004
- Excellent flexibility, kink resistance, easy handling
- ADI free
- Design Factor 3:1
- Vacuum: 0.9 bar

### Tolerances

According to RMA steel mandrel  
Refer to Technical Handbook on page TH34

### Crimp Specifications

For currently qualified crimp specifications including coupling designation, refer to CrimpSource at [www.parker.com/crimpsource-euro](http://www.parker.com/crimpsource-euro).

Part Number	I.D. (mm)	O.D. (mm)	Max. Working Pressure			Weight kg/m	min. Bend Radius mm
			MPa	psi	bar		
IH36242401/40	19	29	1.0	150.0	10	0.67	38
IH36242402/40	25	36	1.0	150.0	10	0.80	50
IH36242404/40	32	44	1.0	150.0	10	1.23	64
IH36242405/40	38	50	1.0	150.0	10	1.38	76
IH36242406/40	40	52	1.0	150.0	10	1.41	80
IH36242408/40	51	64	1.0	150.0	10	1.88	102
IH36242410/40	63.5	77	1.0	150.0	10	2.60	160
IH36242411/40	65	79	1.0	150.0	10	2.66	170
IH36242413/40	76	89	1.0	150.0	10	3.00	190
IH36242414/40	80	93	1.0	150.0	10	3.17	250
IH36242415/20	102	116	1.0	150.0	10	4.60	380

Hose layline example

RUBBER HOSE GAMBRINUS BLUE 10 bar FDA - EC 1935/2004 BfR - D.M. 21/03/73 ADI free



H7

Catalogue 4401/UK

## GAMBRINUS RED 10 SM

Recommended for wine, beer, liqueurs, fruit juice and soft drinks in process, package and transfer phase. Ideal either fixed and mobile installation. Not suitable for fatty food. Designed for suction and delivery.

### Hose Construction

**Tube:** White, smooth EPDM Phthalates free rubber compound, non-toxic, odorless and taste-free. Manufactured on stainless steel mandrel for the maximum cleanliness and hygienic standards

**Reinforcement:** Synthetic textile fabrics and embedded steel wire helix

**Cover:** Red EPDM rubber compound, non-marking, abrasion and weather-resistant

### Temperature Range

-40 °C (-40 °F) to +120 °C (+248 °F)  
sterilization at 130 °C for max 30 min.



- According to FDA, BfR class 2, DM 21/03/73, EC 1935/2004
- Up to 96 % alcoholic content
- Excellent flexibility, kink resistance, easy handling
- ADI free
- Crimped Stainless Steel Fittings available
- Design Factor 3:1
- Vacuum: 0.9 bar

### Tolerances

According to RMA steel mandrel  
Refer to Technical Handbook on page TH34

### Crimp Specifications

For currently qualified crimp specifications including coupling designation, refer to CrimpSource at [www.parker.com/crimpsource-euro](http://www.parker.com/crimpsource-euro).

Part Number							
	I.D. (mm)	O.D. (mm)	MPa	psi	bar	kg/m	min. Bend Radius mm
IH36242501/40	19	29	1.0	150.0	10	0.67	80
IH36242502/40	25	36	1.0	150.0	10	0.80	125
IH36242503/40	30	42	1.0	150.0	10	1.11	150
IH36242504/40	32	44	1.0	150.0	10	1.23	160
IH36242505/40	38	50	1.0	150.0	10	1.38	190
IH36242506/40	40	52	1.0	150.0	10	1.41	200
IH36242507/40	45	57	1.0	150.0	10	1.62	225
IH36242508/40	51	64	1.0	150.0	10	1.88	255
IH36242509/40	60	73	1.0	150.0	10	2.24	300
IH36242510/40	63.5	77	1.0	150.0	10	2.60	320
IH36242511/40	76	89	1.0	150.0	10	3.00	390
IH36242512/40	80	93	1.0	150.0	10	3.17	440
IH36242513/20	102	116	1.0	150.0	10	4.60	560

Hose layline example





## VINITRESS

For delivery of foodstuff in general industrial purposes and for agriculture applications.

### Hose Construction

Flexible, transparent PVC hose having a textile reinforcement between the walls.

### Temperature Range

-20 °C (-4 °F) TO +60 °C (140 °F)  
sterilization at 130 °C for short periods



- According to European Directive EU 10/2011 Class A, B and C
- Low duty mission profile
- Transparent structure to visually monitor the passage of media
- Design Factor 3:1

### Tolerances

Refer to Technical Handbook on page TH34

Part Number	I.D. (mm)	O.D. (mm)	Max. Working Pressure			Weight kg/m	min. Bend Radius mm
			MPa	psi	bar		
IH35033229/100	6	12	2.0	300.0	20	0.10	40
IH35033230/100	8	14	2.0	300.0	20	0.13	50
IH35033223/50	9	15	2.0	300.0	20	0.14	50
IH35033231/100	10	16	2.0	300.0	20	0.15	60
IH35033220/50	13	19	1.2	174.0	12	0.18	80
IH35033222/50	15	21	1.2	174.0	12	0.21	90
IH35033221/50	19	26	1.0	150.0	10	0.30	110
IH35033245/50	25	33	0.8	116.0	8	0.44	150
IH35033241/25	32	42	0.7	101.5	7	0.71	190
IH35033240/25	40	50	0.6	87.0	6	0.86	240

Hose layline example

VINITRESS FOOD QUALITY - MADE IN ITALY - PARKER



# APERSPIR

Suitable for suction and delivery of foodstuff in general industrial purposes and for agriculture applications.

## Hose Construction

Flexible and light hose having an harmonic steel wire helix embedded in a transparent PVC wall.

## Temperature Range

-10 °C (+14 °F) to +60 °C (+140 °F)

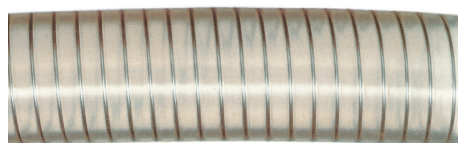

- According to European Directive EU 10/2011 Class A, B and C
- Medium and heavy duty mission profile
- Vacuum: 0.9 bar
- Design factor 3:1

## Tolerances

Refer to Technical Handbook on page TH34

Part Number	I.D. (mm)	Wall (mm)	Max. Working Pressure	Max. Working Pressure			Weight	min. Bend Radius
				MPa	psi	bar		
IH35641012/30	12	3.1	1.2	174.0	12	0.19	24	
IH35641016/50	16	3.1	1.2	174.0	12	0.26	32	
IH35641019/50	19	3	1.1	160.0	11	0.33	28	
IH35641020/50	20	3	1	145.0	10	0.34	30	
IH35641025/50	25	3.7	1	145.0	11	0.52	38	
IH35641030/50	30	3.7	0.9	130.0	9	0.63	45	
IH35641032/50	32	4	0.9	130.0	9	0.66	48	
IH35641038/50	38	4	0.9	130.0	9	0.80	57	
IH35641040/50	40	4.5	0.9	130.0	9	0.95	80	
IH35641045/50	45	4.5	0.9	130.0	9	1.15	67	
IH35641050/50	50	4.9	0.9	130.0	9	1.30	75	
IH35641060/50	60	5.5	0.9	130.0	9	1.75	120	
IH35641075/50	75	6.5	0.9	130.0	9	2.30	150	
IH35641100/30	100	7.5	0.9	130.0	9	3.65	200	
IH35641120/30	120	7.5	0.9	130.0	9	4.30	240	
IH35641125/30	125	7.8	0.9	130.0	9	4.60	250	
IH35641150/20	150	9	0.9	130.0	9	6.50	300	

Hose layline example

APERSPIR I.D. mm. FOOD QUALITY - MADE IN ITALY - PARKER



H10

Catalogue 4401/UK





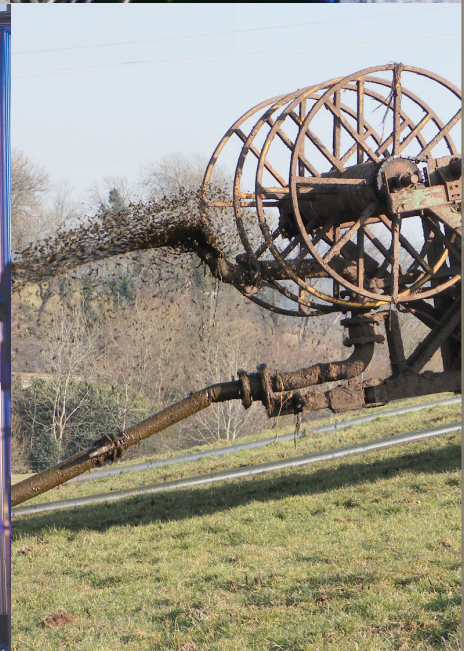
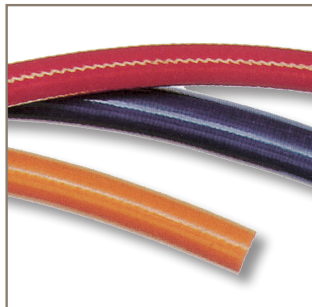

## Multipurpose & Air



ENGINEERING YOUR SUCCESS.

# I – Multipurpose & Air

Hose	ID Range (mm)	Temp. Range (°C)	Application
GST II BLACK 15	5 - 38	-40 / +100	compressed air, non aggressive liquids
GST II RED 15	6.5 - 38	-40 / +100	compressed air, non aggressive liquids
GST II BLACK 20	6.5 - 25	-40 / +100	compressed air, non aggressive liquids
PYTHON NV/L 20	10 - 50	-40 / +120	multipurpose
PYTHON NY/L 30	6 - 100	-40 / +120	multipurpose
JUMBO N/L	13 - 25	-40 / +120	multipurpose
MINIERA 20 MSHA	19 - 50	-30 / +80	compressed air, non aggressive liquids
E-Z FORM™ MP	12.7 - 75	-34 / +120	high flexible hose for multipurpose
OILPRESS N/L 20	6 - 25	-35 / +100	multipurpose
APERFRUT 20	13 - 19	-15 / +60	agricultural spray
APERFRUT 40	10	-15 / +60	agricultural spray
APERFRUT 80	8 - 13	-15 / +60	agricultural spray



	Tube	Reinforcement	Cover	WP (bar)	Design Factor	Suction	Industry standard	Page
	EPDM	textile	EPDM	15	4			I4
	EPDM	textile	EPDM	15	4			I5
	EPDM	textile	EPDM	20	4			I6
	EPDM	textile	EPDM	20	3			I7
	EPDM	textile	EPDM	30	3			I8
	EPDM	textile	EPDM	20	3			I9
	SBR/NBR	textile	CR	20	3		MSHA	I10
	NBR	textile	CR/NBR	5	4	yes		I11
	NBR	textile	NBR/PVC	20	3			I12
	PVC	textile	PVC	20	4			I13
	PVC	textile	PVC	40	3			I13
	PVC	textile	PVC	80	2.5			I13

# GST II BLACK 15

Parker Global Product

*In agriculture, construction, air tool lubricant systems and general industrial for air (including oil mist), mild chemicals and water. Suitable for MRO and OEM channel. Not to be used with oil or refined fuel.*

## Hose Construction

- Tube:** Black EPDM, antistatic rubber compound
- Reinforcement:** Synthetic textile yarns.
- Cover:** Black, smooth EPDM antistatic rubber compound resistant to abrasion, heat and ozone

## Temperature Range

-40 °C (-40 °F) to +100 °C (+212 °F)



- Nitrosamine free
- Permanent fittings capability
- EPDM compound suitable also for oil mist
- Suitable in Atex surroundings
- Design Factor 4:1



## Tolerances

According to UNI EN ISO 1307  
Refer to Technical Handbook on page TH34

## Crimp Specifications

For currently qualified crimp specifications including coupling designation, refer to CrimpSource at [www.parker.com/crimpsource-euro](http://www.parker.com/crimpsource-euro).

Part Number	I.D. (mm)	O.D. (mm)	Max. Working Pressure			Weight kg/m	min. Bend Radius mm
			MPa	psi	bar		
IH709319200/40	5	11	1.5	200.0	15	0.10	40
IH709325200/100	6.5	13	1.5	200.0	15	0.13	50
IH709325200/40	6.5	13	1.5	200.0	15	0.13	50
IH709331200/100	8	15	1.5	200.0	15	0.16	65
IH709331200/40	8	15	1.5	200.0	15	0.16	65
IH709338200/100	9.5	17	1.5	200.0	15	0.20	75
IH709338200/40	9.5	17	1.5	200.0	15	0.20	75
IH709350200/100	13	21	1.5	200.0	15	0.29	105
IH709350200/40	13	21	1.5	200.0	15	0.29	105
IH709363200/100	16	25	1.5	200.0	15	0.36	130
IH709363200/40	16	25	1.5	200.0	15	0.36	130
IH709375200/40	19	28	1.5	200.0	15	0.49	150
IH7093100200/40	25	36	1.5	200.0	15	0.69	200
IH7093125204/40	32	45	1.5	200.0	15	1.15	230
IH7093150204/40	38	52	1.5	200.0	15	2.76	250

Hose layline example





## GST II RED 15

Parker Global Product

*In agriculture, construction, air tool lubricant systems and general industrial for air (including oil mist), mild chemicals and water. Suitable for MRO and OEM channel. Not to be used with oil or refined fuel..*

### Hose Construction

**Tube:** Black EPDM, antistatic rubber compound.  
**Reinforcement:** Synthetic textile yarns  
**Cover:** Red, smooth EPDM insulating rubber compound resistant to abrasion, heat and ozone

### Temperature Range

-40 °C (-40 °F) to +100 °C (+212 °F)



- Nitrosamine free
- Permanent fittings capability
- EPDM compound suitable also for oil mist
- Design Factor 4:1



### Tolerances

According to UNI EN ISO 1307  
 Refer to Technical Handbook on page TH34

### Crimp Specifications

For currently qualified crimp specifications including coupling designation, refer to CrimpSource at [www.parker.com/crimpsource-euro](http://www.parker.com/crimpsource-euro).

Part Number	I.D. (mm)	O.D. (mm)	Max. Working Pressure			Weight kg/m	min. Bend Radius mm
			MPa	psi	bar		
IH709225200/40	6.5	13	1.5	200.0	15	0.13	50
IH709231200/40	8	15	1.5	200.0	15	0.16	65
IH709238200/40	9.5	17	1.5	200.0	15	0.20	75
IH709250200/40	13	21	1.5	200.0	15	0.29	105
IH709263200/40	16	25	1.5	200.0	15	0.36	130
IH709275200/40	19	28	1.5	200.0	15	0.49	150
IH7092100200/40	25	36	1.5	200.0	15	0.69	200
IH7092125204/40	32	45	1.5	200.0	15	1.15	230
IH7092150204/40	38	52	1.5	200.0	15	2.76	250

Hose layline example



# GST II BLACK 20

Parker Global Product

*Designed for compressed air with traces of oil in industrial application. Also suitable in agriculture, construction, and general industry for water, mild chemicals and non aggressive fluids. Not to be used with oil or refined fuel.*

## Hose Construction

- Tube:** Black EPDM, antistatic rubber compound.
- Reinforcement:** Synthetic textile yarns.
- Cover:** Black, smooth EPDM antistatic rubber compound resistant to abrasion, heat and ozone

## Temperature Range

-40 °C (-40 °F) to +100 °C (+212 °F)



- Nitrosamine free
- Permanent fittings capability
- EPDM compound suitable also for oil mist
- Suitable in Atex surroundings
- All sizes on stock
- Design Factor 4:1



## Tolerances

According to UNI EN ISO 1307  
Refer to Technical Handbook on page TH34

## Crimp Specifications

For currently qualified crimp specifications including coupling designation, refer to CrimpSource at [www.parker.com/crimpsource-euro](http://www.parker.com/crimpsource-euro).

Part Number	I.D. (mm)	O.D. (mm)	Max. Working Pressure			Weight kg/m	min. Bend Radius mm
			MPa	psi	bar		
IH709325300/100	6.5	14	2.0	300.0	20	0.16	50
IH709331300/100	8	16	2.0	300.0	20	0.20	65
H709332300/100	8	17	2.0	300.0	20	0.21	70
IH709338300/100	9.5	17.5	2.0	300.0	20	0.23	75
IH709350304/100	13	22	2.0	300.0	20	0.36	105
IH709363304/100	16	27	2.0	300.0	20	0.52	130
IH709375304/40	19	29.5	2.0	300.0	20	0.56	150
IH7093100304/40	25	36.5	2.0	300.0	20	0.75	200

Hose layline example



# PYTHON NV/L 20

Designed for air, cold and hot water and light-chemical media. Major properties of PYTHON hoses are:

- high ozone resistance
- antistatic resistance
- high temperature resistance
- low temperature resistance
- non-staining cover
- high flexibility

## Hose Construction

- Tube:** Black, antistatic, smooth EPDM nitrosamine free rubber compound, resistant to light-chemical media
- Reinforcement:** Synthetic textile yarns
- Cover:** Green, smooth EPDM nitrosamine free rubber compound

## Temperature Range

-40 °C (-40 °F) to +120 °C (+248 °F)  
with peaks to +140 °C (+284 °F)



- Unmatchable handiness
- Its versatility of use helps to keep a controlled stock
- Wide range temperature
- Nitrosamine free
- Design Factor 3:1



## Tolerances

I.D. ≤ 25 mm according to UNI EN ISO 1307  
I.D. > 25 mm according to RMA steel mandrel  
*Refer to Technical Handbook on page TH34*

## Crimp Specifications

For currently qualified crimp specifications including coupling designation, refer to CrimpSource at [www.parker.com/crimpsource-euro](http://www.parker.com/crimpsource-euro).

Part Number							
	I.D. (mm)	O.D. (mm)	MPa	psi	bar	kg/m	min. Bend Radius mm
IH30351200/40	10	17	2.0	300.0	20	0.22	60
IH30351201/40	13	20	2.0	300.0	20	0.26	80
IH30351202/40	15	22	2.0	300.0	20	0.29	90
IH30351203/40	19	27	2.0	300.0	20	0.41	110
IH30351204/40	25	34	2.0	300.0	20	0.60	150
IH36351201/40	32	44	2.0	300.0	20	0.98	320
IH36351202/40	38	51	2.0	300.0	20	1.20	380
IH36351203/40	42	56	2.0	300.0	20	1.42	420
IH36351204/40	50	66	2.0	300.0	20	1.76	500

Hose layline example





## PYTHON NY/L 30

Designed for air, cold and hot water and light-chemical media. Major properties of PYTHON hoses are:

- high ozone resistance
- antistatic resistance
- high temperature resistance
- low temperature resistance
- non-staining cover
- high flexibility

### Hose Construction

<b>Tube:</b>	Black, antistatic, smooth EPDM nitrosamine free rubber compound, resistant to light-chemical media
<b>Reinforcement:</b>	Synthetic textile yarns
<b>Cover:</b>	Yellow, smooth EPDM nitrosamine free rubber compound

### Temperature Range

-40 °C (-40 °F) to +120 °C (+248 °F)  
with peaks to +140 °C (+284 °F)



- Unmatchable handiness
- Its versatility of use helps to keep a controlled stock
- Wide range temperature
- Nitrosamine free
- Design Factor 3:1



### Tolerances

I.D. ≤ 25 mm according to UNI EN ISO 1307  
I.D. > 25 mm according to RMA steel mandrel  
Refer to Technical Handbook on page TH34

### Crimp Specifications

For currently qualified crimp specifications including coupling designation, refer to CrimpSource at [www.parker.com/crimpsource-euro](http://www.parker.com/crimpsource-euro).

Part Number	I.D. (mm)	O.D. (mm)	Max. Working Pressure			Weight kg/m	min. Bend Radius mm
			MPa	psi	bar		
IH30351251/40	8	17	3.0	450.0	30	0.25	50
IH30351252/40	10	20	3.0	450.0	30	0.34	60
IH30351253/40	13	23	3.0	450.0	30	0.40	80
IH30351254/40	16	27	3.0	450.0	30	0.52	100
IH30351255/40	19	30	3.0	450.0	30	0.60	110
IH30351256/40	25	37	3.0	450.0	30	0.88	150
IH36351250/40	32	44	3.0	450.0	30	0.95	320
IH36351251/40	38	51	3.0	450.0	30	1.20	380
IH36351252/40	42	56	3.0	450.0	30	1.45	420
IH36351253/40	50	66	3.0	450.0	30	1.93	500
IH36351254/20	65	82	3.0	450.0	30	2.50	650
IH36351255/20	76	92	3.0	450.0	30	3.08	750
IH36351256/20	100	122	3.0	450.0	30	5.05	1000

Hose layline example



# JUMBO

*Suitable for the discharge of hot and cold water, air and light-chemical media in many industrial and agricultural applications.*

## Hose Construction

- Tube:** Black, smooth EPDM antistatic nitrosamine free rubber compound
- Reinforcement:** Synthetic textile yarns
- Cover:** Black, smooth EPDM rubber compound insulating with nitrosamine free rubber compound with three red, longitudinal and different stripes, resistant to abrasion, heat and weathering

## Temperature Range

-40 °C (-40 °F) to +120 °C (+248 °F)



- Agriculture, construction and general industrial
- Long lasting embossed type branding
- Three red strips for easy hose identification
- Nitrosamine free
- Design Factor 3:1



## Tolerances

According to UNI EN ISO 1307  
Refer to Technical Handbook on page TH34

## Crimp Specifications

For currently qualified crimp specifications including coupling designation, refer to CrimpSource at [www.parker.com/crimpsource-euro](http://www.parker.com/crimpsource-euro).

Part Number	I.D. (mm)	O.D. (mm)	Max. Working Pressure			Weight kg/m	min. Bend Radius mm
			MPa	psi	bar		
IH30116500/40	13	19	2.0	300.0	20	0.21	75
IH30116501/40	15	22	2.0	300.0	20	0.31	90
IH30116502/40	19	27	2.0	300.0	20	0.60	110
IH30116504/40	25	34	2.0	300.0	20	0.74	150

Hose layline example





## MINIERA 20 MSHA

Suitable for compressed air tools in factories and designed for quarries, building and mining industries. Tube resistant to traces of oil mist for medium duty.

### Hose Construction

- Tube:** Black, oil mist resistant, smooth SBR/NBR rubber compound
- Reinforcement:** Synthetic textile fabrics
- Cover:** Black, abrasion, ageing and weather-resistant CR nitrosamine free rubber compound

### Temperature Range

-30 °C (-22 °F) to +80 °C (+176 °F)

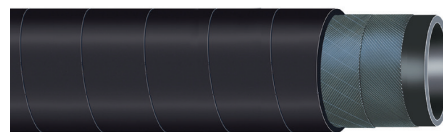

- Also suitable for water and air in general service applications
- Nitrosamine free compounds
- Design Factor 3:1
- MSHA approved cover



### Tolerances

According to RMA steel mandrel  
Refer to Technical Handbook on page TH34

Part Number	I.D. (mm)	O.D. (mm)	Max. Working Pressure			Weight kg/m	min. Bend Radius mm
			MPa	psi	bar		
IH36342161/40	19	30	2.0	300.0	20	0.62	190
IH36342162/40	25	37	2.0	300.0	20	0.81	250
IH36342163/40	30	42	2.0	300.0	20	0.98	300
IH36342164/40	32	46	2.0	300.0	20	1.24	320
IH36342165/40	38	52	2.0	300.0	20	1.43	380
IH36342168/40	50	66	2.0	300.0	20	2.08	500

Hose layline example



# E-Z FORM™ MP

Parker Global Product

*Suitable for biodiesel, diesel, ethanol and gasoline in oil suction/return lines, vehicle fuel fill connector lines, drain lines on buses, cranes, mobile off-road equipment. Extremely flexible and lightweight it reduces installation times, eliminates special design, tooling and fabrication cost. Capable of being routed through confined spaces where pre-shaped and formed hose are normally required. Do not use for fuel dispensing or drag across sharp edges or very abrasive surfaces.*

## Hose Construction

- Tube:** Black NBR, antistatic rubber compound
- Reinforcement:** Multiple textile plies with wire helix
- Cover:** Black, Greek corrugated CR rubber compound resistant to oil and weathering

## Temperature Range

ID up to 25 mm: -34 °C (-30 °F) to +121 °C (+250 °F)  
all other sizes: -29 °C (-20 °F) to +93 °C (+200 °F)

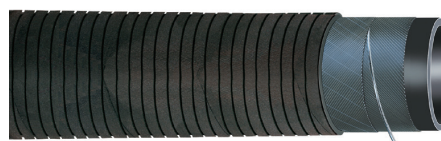

- Saves time and costs thanks to easy and quick assembly
- Superior kink resistance, minimal force to bend, outstanding flexibility
- Permanent fittings capability
- Design Factor 4:1
- Vacuum: 0.9 bar

## Tolerances

According to UNI EN ISO 1307  
Refer to Technical Handbook on page TH34

## Crimp Specifications

For currently qualified crimp specifications including coupling designation, refer to CrimpSource at [www.parker.com/crimpsource-euro](http://www.parker.com/crimpsource-euro).

Part Number							
	I.D. (mm)	O.D. (mm)	MPa	psi	bar	kg/m	min. Bend Radius mm
IH72190500/10	12.7	23.8	1.0	150	10	0.45	23
IH72190625/10	15.9	27.0	1.0	150	10	0.55	33
IH72190750/10	19.1	30.0	1.0	150	10	0.58	36
IH72191000/10	25.4	36.0	1.0	150	10	0.68	36
IH72191250/10	32.0	43.0	0.5	75	5	0.75	56
IH72191500/10	38.0	49.0	0.5	75	5	0.85	74
IH72192000/10	51.0	63.0	0.5	75	5	1.44	117
IH72192500/10	63.5	76.5	0.5	75	5	1.74	183
IH72193000/10	76.0	90.0	0.5	75	5	2.23	223
IH72193500/10	88.9	104.0	0.5	75	5	2.86	298

Hose layline example





## OILPRESS N/L 20

Suitable for multi-purpose applications requiring transfer of many types of fluids and for petroleum products with aromatic content not exceeding 50 %.

### Hose Construction

- Tube:** Smooth, black, oil and fuel resistant NBR rubber compound, suitable for petroleum products with aromatic content not exceeding 50 %
- Reinforcement:** Synthetic textile yarns
- Cover:** Smooth, black, antistatic (R < 1 MΩ/m) heat, oil, abrasion and weather resistant NBR/PVC rubber compound

### Temperature Range

-35 °C (-31 °F) to +100 °C (+212 °F), with peaks up to +120 °C (+248 °F) for oil



- Agriculture, construction and general industrial
- Suitable for many different fuels included Biodiesel B100
- Two different Working Pressure lines
- Wide range temperature
- Design Factor 3:1

### Tolerances

According to UNI EN ISO 1307  
Refer to Technical Handbook on page TH34

### Crimp Specifications

For currently qualified crimp specifications including coupling designation, refer to CrimpSource at [www.parker.com/crimpsource-euro](http://www.parker.com/crimpsource-euro).

Part Number	I.D. (mm)	O.D. (mm)	Max. Working Pressure			Weight kg/m	min. Bend Radius mm
			MPa	psi	bar		
OILPRESS N/L 20							
IH30832000/40	6	12	2.0	300.0	20	0.12	25
IH30832001/40	8	14	2.0	300.0	20	0.15	35
IH30832002/40	10	17	2.0	300.0	20	0.21	40
IH30832003/40	13	20	2.0	300.0	20	0.26	55
IH30832004/40	16	23	2.0	300.0	20	0.31	65
IH30832005/40	19	28	2.0	300.0	20	0.47	80
IH30832006/40	25	36	2.0	300.0	20	0.74	100

Hose layline example



# APERFRUT 20 - 40 - 80

For delivery of air, water and all fungicide products. Particularly suitable for spraying in agriculture. Resistant to compressor oil-mist.

## Hose Construction

- Tube:** Black, smooth, PVC compound
- Reinforcement:** Synthetic textile yarns
- Cover:** Orange (20), red (40) and blue (80), smooth, abrasion, and weather-resistant PVC compound

## Temperature Range

-15 °C (+5 °F) to +60 °C (+140 °F)

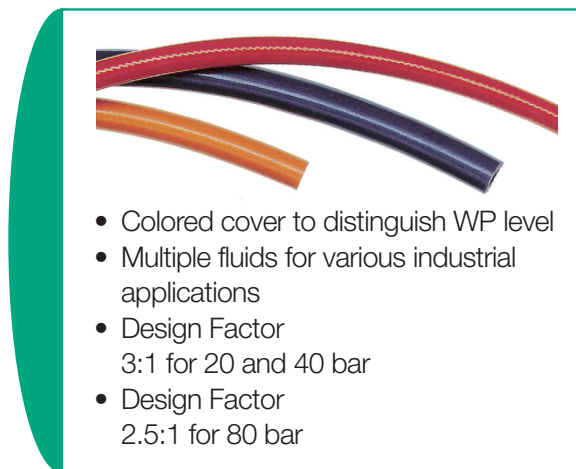

- Colored cover to distinguish WP level
- Multiple fluids for various industrial applications
- Design Factor 3:1 for 20 and 40 bar
- Design Factor 2.5:1 for 80 bar

## Tolerances

Refer to Technical Handbook on page TH34

Part Number	I.D. (mm)	O.D. (mm)	Max. Working Pressure			Weight kg/m	min. Bend Radius mm
			MPa	psi	bar		
<b>APERFRUT 20</b>							
IH35040014/100	13	19	2.0	300.0	20	0.22	70
IH35040016/100	19	26.5	2.0	300.0	20	0.38	100
<b>APERFRUT 40</b>							
IH35040261/100	10	16	4.0	600.0	40	0.19	50
<b>APERFRUT 80</b>							
IH35040268/100	8	15	8.0	1200.0	80	0.17	40
IH35040270/100	10	18	8.0	1200.0	80	0.26	50
IH35040214/100	13	21	8.0	1200.0	80	0.38	70

Hose layline example

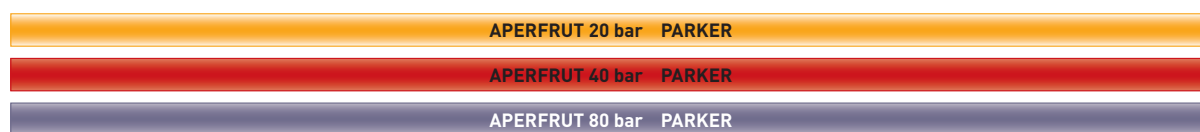



EMEA Product Information Centre  
Free phone: 00 800 27 27 5374  
(from AT, BE, CH, CZ, DE, DK, EE, ES, FI, FR, IE, IL,  
IS, IT, LU, MT, NL, NO, PL, PT, RU, SE, SK, UK, ZA)  
US Product Information Centre  
Toll-free number: 1-800-27 27 537  
[www.parker.com](http://www.parker.com)

CAT/4401/UK April 2025

Your Local Authorized Parker Distributor

© 2025 Parker Hannifin Corporation

