

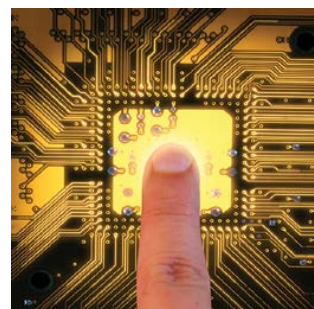

IQAN-G12 **Remote Diagnostics**

Electronic Control Systems



ENGINEERING YOUR SUCCESS.

IQAN-G12

Easy wireless access to machine at any time

Application

The IQAN-G12 is a CAN gateway using Bluetooth® wireless technology for IQAN system diagnostics on-site or remotely. It is designed to transmit diagnostic data from the IQAN system to a user's smartphone or a tablet with IQANgo app, or to a PC with IQANrun.

The IQAN-G12 gateway enables accessible communication with the IQAN master modules in machine control systems. To ensure efficient interaction, the IQAN-G12 transfers data more than four times faster than the previous model G11. Connection security is increased by device pairing and encryption (IQANdesign 6.08 or later version).

The IQAN-G12 is backwards compatible with the IQAN-G11, and works also on systems running previous IQANdesign versions.

Installation

The IQAN-G12 is designed to be easily mounted in a vehicle interior or on an exterior panel. There is 1 LED provided for status signals. The unit has a molded plastic housing and built-in, sealed connector. The rugged design of the IQAN-G12 is ideal for harsh environments and constructed to be weatherproof for outdoor use.

Connectivity

The IQAN-G12 solution, together with IQAN software tools, enables easy on-site or remote access to machines. Fast diagnostic and data transfer makes real-time measurement, parameter adjustment and updating of applications quick and easy.

The IQAN system offers exceptional added value through reduced diagnostic time, as access to the machine is possible wherever there is mobile phone coverage. Service technicians are better prepared and can resolve issues quicker, saving time and offering better service to the end user.

General

Weight	60 g
Temperature range	
- Operating, ambient	-30 to +70°C
- Storage, ambient	-40 to +85°C
Protection	Installation on mobile machinery
Voltage supply	12 or 24 Vdc nominal
Current consumption	
- 14 Vdc	60 mA
- 28 Vdc	30 mA
Start up time	< 3 seconds

Communication interfaces

CAN	1
- Bus speed	250 kbps
- Bus speed CAN FD	500 kbps/2Mbps
- Protocol	IQAN Diagnostic Protocol
Bluetooth	1
- Protocol	Bluetooth 5.2 LE
- Range	up to 30m

Connector interfaces

Power/CAN	Deutsch DT, 4 pin
-----------	-------------------

Ordering part number

IQAN-G12	20085200
Connector	5031113

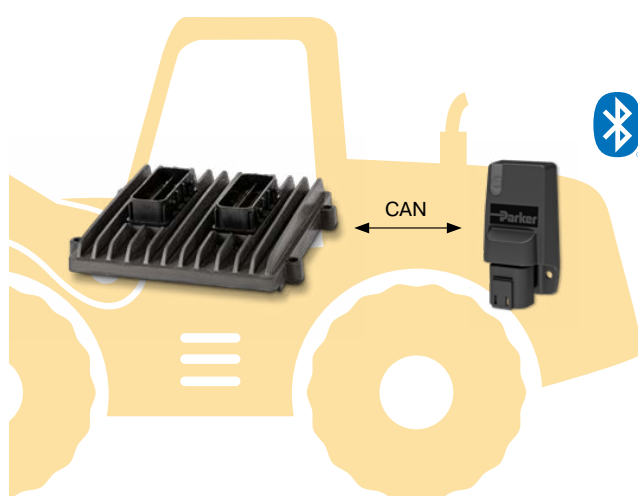

On site access



Remote access

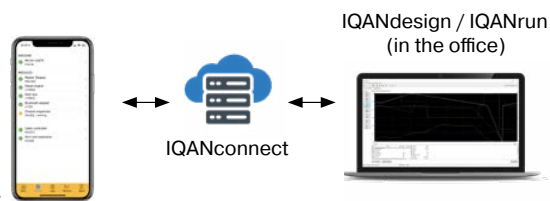

Environmental protection

EMC harmonized standards

ISO 14982:2009, EN ISO 13766-1:2018

Climate environment

ISO 20653-2013 IP6K9K (enclosure, dust, water)
 IEC 60068-2-30:2005 Db (damp heat, cyclic)
 IEC 60068-2-78:2001 Cab (damp heat, steady state)
 IEC 60068-2-2:2007 Bb (heat)
 IEC 60068-2-1:1993 Ab (cold)
 IEC 60068-2-14:1984 Nb (change of temperature)

Mechanical environment

IEC 60068-2-64:2008 Fh (random)
 IEC 60068-2-27:2008 Ea (bump)

Markings / Approvals

FCC (United States)	FCC ID: QOQ-BGM220S2
ISED (Canada)	ISED: 5123A-BGM220S2
CE (Europe)	2014/53/EU, Radio Directive (RED) 2011/65/EU, ROHS 2, 2015/863 RoHS 2 amendment
E-mark	ECE R10 rev 06
Great Britain UKCA	Radio Equipment Regulations 2017
Japan MIC	R209-J00429

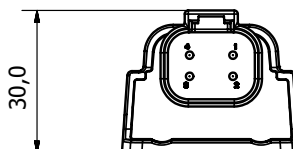

See the IQAN-G12 instruction book for further information.

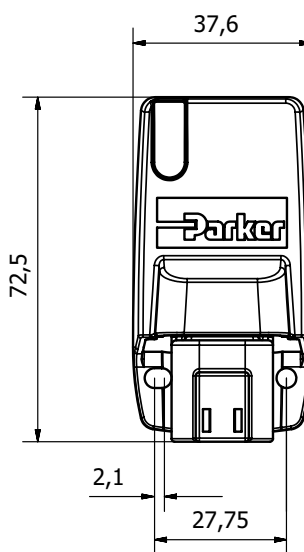
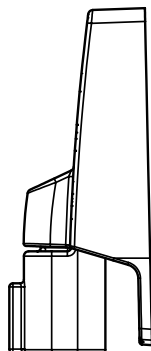

iPhone is a trademark of Apple Inc., registered in the U.S. and other countries.

The Bluetooth® word mark and logos are registered trademarks owned by Bluetooth SIG, Inc. and any use of such marks by Parker Hannifin Corporation is under license. Other trademarks and trade names are those of their respective owners.



WARNING - USER RESPONSIBILITY

FAILURE OR IMPROPER SELECTION OR IMPROPER USE OF THE PRODUCTS DESCRIBED HEREIN OR RELATED ITEMS CAN CAUSE DEATH, PERSONAL INJURY AND PROPERTY DAMAGE.

This document and other information from Parker-Hannifin Corporation, its subsidiaries and authorized distributors provide product or system options for further investigation by users having technical expertise.

The user, through its own analysis and testing, is solely responsible for making the final selection of the system and components and assuring that all performance, endurance, maintenance, safety and warning requirements of the application are met. The user must analyze all aspects of the application, follow applicable industry standards, and follow the information concerning the product in the current product catalog and in any other materials provided from Parker or its subsidiaries or authorized distributors.

To the extent that Parker or its subsidiaries or authorized distributors provide component or system options based upon data or specifications provided by the user, the user is responsible for determining that such data and specifications are suitable and sufficient for all applications and reasonably foreseeable uses of the components or systems.

Offer of Sale

Please contact your Parker representation for a detailed "Offer of Sale".

WARNING

This product can expose you to chemicals including LEAD AND LEAD COMPOUNDS which is known to the State of California to cause cancer. For more information go to www.P65Warnings.ca.gov

www.parker.com



European Headquarters
La Tuilière 6, 1163 Etoy,
Switzerland
Tel: +41 21 821 85 00

Your authorized Distributor