



## Valves

### WV Alternating valve

EO 24° cone end / EO 24° cone end / EQ 24° cone end

These valves permit the passage of flow from either inlet 1 or 2 to the outlet port whilst shutting of the inlet port not in use. The shutting off, of an inlet is achieved by a floating ball bearing which moves by the pressure of the flow.

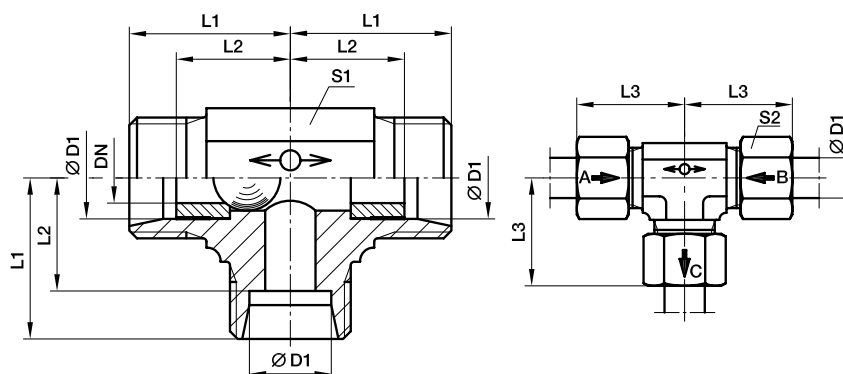

Material: steel  
Surface finish: Cr(VI)-free.

Valves are not recommended for compressed air and gases. WV-valves are not to be used in connection with weld nipples, swivel nuts etc. where there is no contact with a shoulder stop in the inner cone.

Temperature range without pressure reductions: -40°C up to +120°C.

Recommended fitting position as shown in the picture.

Leakage rate for alternating valves hydraulic test with test pressure =  $P_{max}$ : approx. 20 drops (test period of 1 minute).

Directions of flow:

$D_1 \rightarrow D_3 = D_2$  closed  
 $D_2 \rightarrow D_3 = D_1$  closed

Series	D1	T1	DN	L1	L2	L3	S1	S2	Weight g/1 piece	Order code*	PN (bar) <sup>1)</sup> CF
L <sup>3)</sup>	8	M 14×1.5	4.5	21	14	29	14	17	53	<b>WV08LOMD</b>	160
	10	M 16×1.5	6.0	22	15	30	17	19	73	<b>WV10LOMD</b>	160
	12	M 18×1.5	7.5	24	17	32	19	22	96	<b>WV12LOMD</b>	160
	15	M 22×1.5	10.0	28	21	36	19	27	134	<b>WV15LOMD</b>	160

<sup>1)</sup> Pressure shown = item deliverable

<sup>3)</sup> L = light series

$\frac{PN \text{ (bar)}}{10} = PN \text{ (MPa)}$

Delivery without nut and ring. Information on ordering complete fittings or alternative sealing materials see page P56.

\*Please add the **suffixes** below according to the material/surface required.

Order code suffixes			
Material	Suffix surface and material	Example	Standard sealing material (no additional suffix needed)
Steel, zinc plated, Cr(VI)-free	CF	WV08LOMDCF	Steel ball