

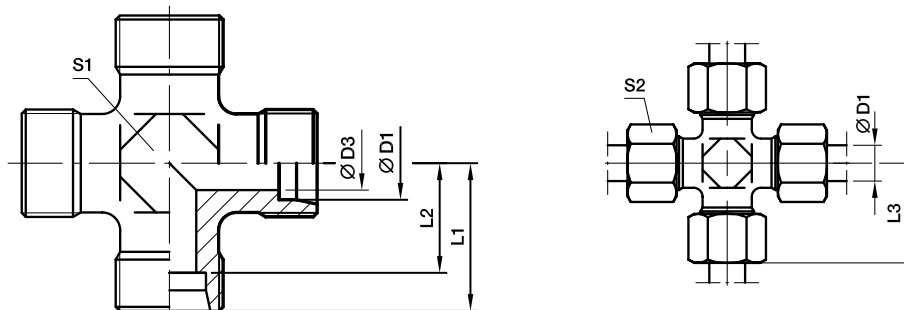

K Union cross

EO 24° cone end



Series	D1 ⊙	D3	L1	L2	L3	S1	S2	Weight g/1 piece	Order code*	PN (bar) ¹⁾		
										CF	71	MS
LL ²⁾	04	3.0	15	11.0	21	9	10	13	K04LL	100	100	63
	06	4.5	15	9.5	21	9	12	14	K06LL	100	100	63
	08	6.0	17	11.5	23	12	14	24	K08LL	100	100	63
L ³⁾	06	4.0	19	12.0	27	12	14	35	K06L	315	315	200
	08	6.0	21	14.0	29	12	17	40	K08L	315	315	200
	10	8.0	22	15.0	30	14	19	52	K10L	315	315	200
	12	10.0	24	17.0	32	17	22	69	K12L	315	315	200
	15	12.0	28	21.0	36	19	27	130	K15L	315	315	200
	18	15.0	31	23.5	40	24	32	188	K18L	315	315	200
	22	19.0	35	27.5	44	27	36	251	K22L	160	160	100
	28	24.0	38	30.5	47	36	41	392	K28L	160	160	100
	35	30.0	45	34.5	56	41	50	618	K35L	160	160	100
	42	36.0	51	40.0	63	50	60	905	K42L	160	160	100
S ⁴⁾	06	4.0	23	16.0	31	12	17	58	K06S	630	630	400
	08	5.0	24	17.0	32	14	19	82	K08S	630	630	400
	10	7.0	25	17.5	34	17	22	97	K10S	630	630	400
	12	8.0	29	21.5	38	17	24	146	K12S	630	630	400
	14	10.0	30	22.0	40	19	27	176	K14S	400	400	250
	16	12.0	33	24.5	43	24	30	220	K16S	400	400	250
	20	16.0	37	26.5	48	27	36	339	K20S	315	315	200
	25	20.0	42	30.0	54	36	46	576	K25S	315	315	200
	30	25.0	49	35.5	62	41	50	843	K30S	315	315	200
	38	32.0	57	41.0	72	50	60	1350	K38S	315	315	200

¹⁾ Pressure shown = item deliverable

²⁾ LL = very light series; ³⁾ L = light series; ⁴⁾ S = heavy series

$\frac{\text{PN (bar)}}{10} = \text{PN (MPa)}$

Delivery without nut and ring. Information on ordering complete fittings see page 17.

*Please add the **suffixes** below according to the material/surface required.

Order code suffixes		
Material	Suffix surface and material	Example
Steel, zinc plated, Cr(VI)-free	CFX	K16SCFX
Stainless Steel	71X	K16S71X
Brass	MSX	K16SMSX