

# Universal Series, Vented

## 0489 3/2 In-Line Vented Ball Valve, Female BSPP and Metric Thread

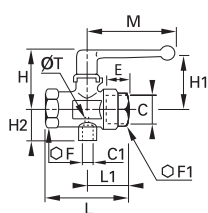

Nickel-plated brass, NBR



C	C1	DN		E	F	F1	H	H1	H2	L	L1	M	ØT	kg
G1/4	M5x0.8	7	<a href="#">0489 07 13</a>	12	24	24	46	43	17	59	31	69	2	0.270
G3/8	M5x0.8	10	<a href="#">0489 10 17</a>	12	24	24	46	43	17	59	31	69	2	0.243
G1/2	G1/8	13	<a href="#">0489 13 21</a>	15	27	27	47	44	24	67	34	69	2	0.310
G3/4	G1/4	18	<a href="#">0489 18 27</a>	16.5	32	38	63	54	33	80	39	108	2.5	0.670
G1	G1/4	23	<a href="#">0489 23 34</a>	19	41	46	67	57	37	94	47	108	3	1.050

Maximum working pressure: 40 bar

## 0449 3/2 Panel-Mountable In-Line Ball Valve, Female BSPP and Metric Thread



Nickel-plated brass, NBR

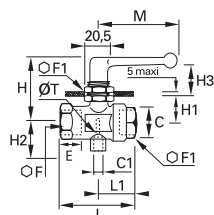

C	C1	DN		E	F	F1	H	H1	H2	H3	L	L1	M	ØT	kg
G1/4	M5x0.8	7	<a href="#">0449 07 13</a>	12	24	27	50	20	17	21	59	31	69	2.5	0.313
G3/8	M5x0.8	10	<a href="#">0449 10 17</a>	12	24	27	50	20	17	21	59	31	69	2.5	0.291
G1/2	G1/8	13	<a href="#">0449 13 21</a>	15	27	27	52	23	24	21	67	34	69	4	0.352

Maximum working pressure: 20 bar

## 0469 3/2 In-Line Vented Ball Valve, Female BSPP Thread



Nickel-plated brass, NBR

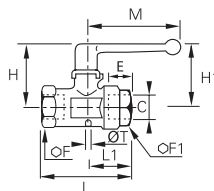

C	DN		E	F	F1	H	H1	L	L1	M	ØT	kg
G1/8	4	<a href="#">0469 04 10</a>	8	14	14	35	29	44	25	48	1.5	0.092
G1/4	7	<a href="#">0469 07 13</a>	12	24	24	46	43	59	31	70	2	0.268
G3/8	10	<a href="#">0469 10 17</a>	12	24	24	46	43	59	31	70	2	0.246
G1/2	13	<a href="#">0469 13 21</a>	15	27	27	47	44	67	34	70	2	0.294
G3/4	18	<a href="#">0469 18 27</a>	16.5	32	38	63	54	80	39	108	2.5	0.668
G1	23	<a href="#">0469 23 34</a>	19	41	46	67	57	94	47	108	3	1.026

Maximum working pressure: 40 bar

### Operation of Vented Ball Valves

With vent connected to a tube = collection of purged media

With vent connected to a silencer = noiseless discharge to atmosphere

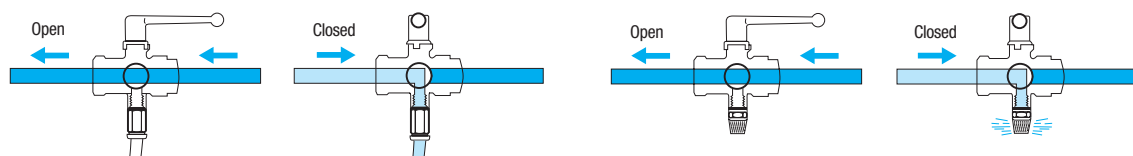

You will find our ranges of fittings, tubing and silencers in Chapters 1, 3 and 9.

# Universal Series, Vented

## 0462 3/2 Right-Angled Ball Valve with Vent, Female BSPP Thread

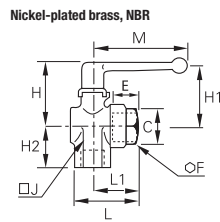

C	DN		E	F	H	H1	H2	J	L	L1	M	kg
G1/8	6	<a href="#">0462 06 10</a>	8	19	38	31	20	22	37	27	48	0.192
G1/4	6	<a href="#">0462 06 13</a>	12	19	38	31	24	22	38	28	48	0.185
G3/8	9	<a href="#">0462 09 17</a>	12	24	45	43	27	25	46	31	69	0.261
G1/2	12	<a href="#">0462 12 21</a>	15	27	47	44	33	29	49	34	69	0.312
G3/4	18	<a href="#">0462 18 27</a>	16.5	38	59	51	40	39	60	39	108	0.698
G1	23	<a href="#">0462 23 34</a>	19	46	63	55	47	48	72	47	108	1.066

Maximum working pressure: 20 bar

## 0461 3/2 Right-Angled Ball Valve with Vent, Male/Female BSPP Thread

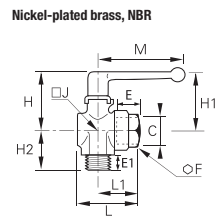

C	DN		E	E1	F	H	H1	H2	J	L	L1	M	kg
G1/8	6	<a href="#">0461 06 10</a>	8	7	19	38	31	20	22	37	27	48	0.182
G1/4	6	<a href="#">0461 06 13</a>	12	9	19	38	31	24	22	38	28	48	0.186
G3/8	9	<a href="#">0461 09 17</a>	12	11	24	45	43	27	25	46	31	69	0.257
G1/2	12	<a href="#">0461 12 21</a>	15	12	27	47	44	33	29	49	34	69	0.304
G3/4	18	<a href="#">0461 18 27</a>	16.5	12	38	59	51	40	39	60	39	108	0.648

Maximum working pressure: 20 bar

### Operation of Right-Angled Vented Ball Valves

With pin-hole vent = purge to atmosphere without silencer

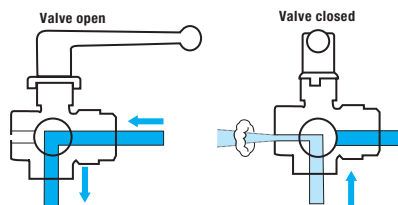

### Operation of Lockable Vented Ball Valves

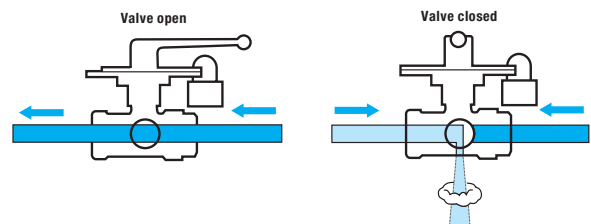

**Removable lever:** where the lever is obstructed in its movement, it can be refitted the opposite way.

### Operation of 3/2 Lockable Valves

Drilled below and square in the horizontal plane, these valves provide a connection between: either port 1 and port 2, or port 2 and port 3.

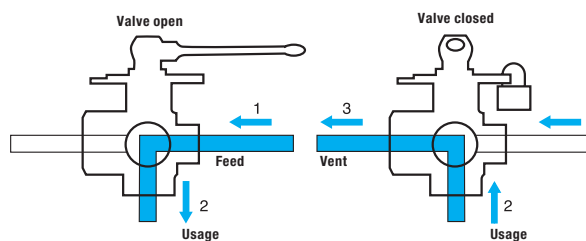

**Removable lever:** where the lever is obstructed in its movement, it can be refitted the opposite way.

# Ball Valves, Universal Series

This range of valves has patented **seal wear compensating** technology for **reliable** and **durable** sealing, **protecting** any system whether under pressure or **vacuum**.

## Product Advantages

**Durability & Reliability**

- Automatic seal wear compensation for long-term reliability
- Robust, corrosion-resistant materials
- 100% leak-tested in production
- Date coding to guarantee quality and traceability

**Versatility & Performance**

- Ideal for ensuring the performance of pneumatic circuits
- Customised valves for all special applications
- Unequalled performance under vacuum
- Smooth operation thanks to self-lubricating seals
- Large range of working pressures and temperatures
- Lever can be repositioned and replaced
- Many configurations to satisfy all system requirements



**Applications**

- Pneumatics
- Vacuum
- Transportation
- Packaging
- Textile
- Sawmill
- Rubber & Plastics

## Technical Characteristics

<b>Compatible Fluids</b>	Industrial fluids
<b>Working Pressure</b>	Vacuum to 40 bar
<b>Working Temperature</b>	-20°C to +80°C

<b>Tightening Torques</b>	Threads	G1/8	G1/4	G3/8	G1/2	G3/4	G1	
	daN.m	0.10 to 0.20	0.10 to 0.20	0.15 to 0.25	0.20 to 0.35	0.50 to 0.70	0.50 to 0.70	
	Threads	G1¼	G1½	G2				
	daN.m	0.40 to 0.60	0.80 to 1.20	0.80 to 1.20				

Reliable performance is dependent upon the type of fluid conveyed, component materials and tubing being used.  
Guaranteed for use with a vacuum of 755 mm Hg (99 % vacuum).

### Component Materials

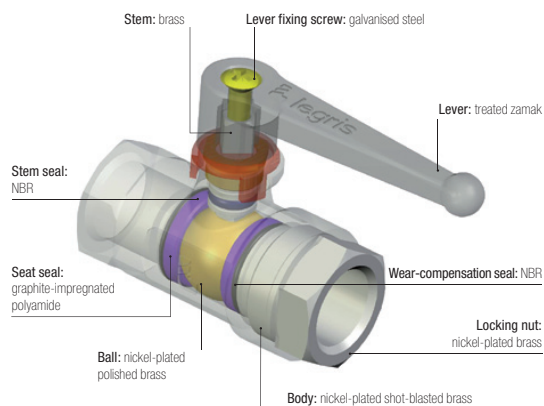

### Silicone-free

### Regulations

DI: 97/23/EC (module PED A - diameters greater than 25 mm)  
DI: 2006/42/EC (Machinery Directive)  
DI: 2002/95/EC (RoHS)  
RG: 1907/2006 (REACH)

# Universal Series

## Installation Options

### Lockable Valves

Our lockable ball valves have been developed in order to prevent potentially dangerous consequences caused by unintended operation. Lockable in different positions, this range meets international safety requirements, such as ISO 4414.

The valves are lockable:

- at one point: models 0432 and 0439
- at three points: models 0437 and 0438

### Vented Valves

To stop fluid circulation and vent the circuit, 2 venting systems are provided:

- with threaded exhaust, to allow discharge of downstream media
- with pin-hole vent, for applications with no special discharge requirement

Fluid flow direction is indicated by an arrow on the valve body.

### Mountable Valves

On steel plate:

- bulkhead fixing
- complete valve below bulkhead

On frame:

- assemble with bolts

On wooden panel:

- assemble with woodscrews

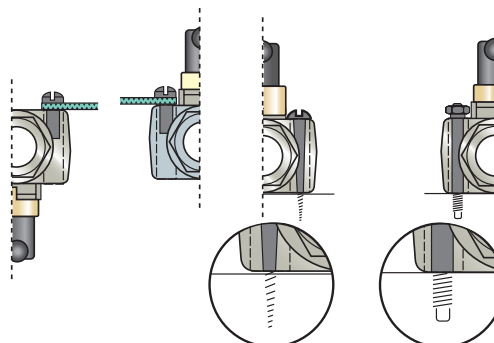

### Universal Customised Valve Series

Based on the standard components of the universal series, this range allows the valve to be adapted to specific needs. There are 6 product versions available on request.

#### Product Codes

Valve type	<b>0402 04 10 22</b>	
0400		Thread
0401		
0402	04 = 4 mm	10 = 1/8"
...	05 = 5 mm	13 = 1/4"
	...	...
	40 = 40 mm	48 = 2"
		<b>Suffix</b>
		20 = blue/red
		22 = green/blue
		26 = yellow/yellow
		27 = blue/green
		30 = white/red
		32 = white/green

#### Identification

Each series may be easily identified by a colour marking on the lever.

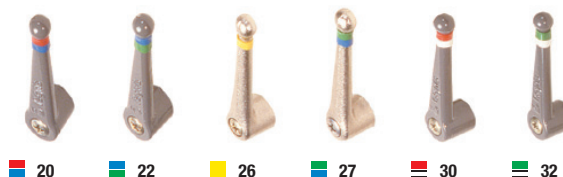

#### Suffix Specification

Identification		Body		Lever			Ball		Stem and Wear-Compensation Seals			Seat Seals			Application Examples
Suffix on the body	Colour bands on the lever	Nickel-plated brass	Chemical nickel-plated brass	Standard	Nickel-plated brass	Chemical nickel-plated brass	Nickel-plated polished brass	Chemical nickel-plated brass	EPDM	FKM	PTFE white	Rilsan: graphite-impregnated	Filled PTFE	PTFE white	
20		•		•			•			•		•			Hydrocarbons
22		•		•				•		•			•		Industrial fluids and high temperature
26*		•			•			•			•	olive		•	Corrosive liquids or high temperature
27			•			•		•		•			•		Industrial fluids and/or harsh environments
30**		•		•			•		•			•			Gaseous oxygen circuits
32		•		•				•	•				•		Water and steam circuits

\*degreased \*\*oxygen-compatible grease

A usage chart in this chapter shows which type of valve to use according to the fluid being conveyed.

# Ball Valves: Usage Chart

The chart below shows the compatibility between valves and fluids along with their pressure and temperature characteristics.

Certain models have a maximum working pressure which differs from that given in this table. In this case, the pressure is shown in the heading for the model number in question.

N.B.: Above 32 mm or 1¼" diameters, divide the maximum pressure by 2.

If the fluid you are using is not shown in this chart, please contact us.

Chemical Description	Maximum Pressure (bar)	Temperature °C		Universal and Light Series	Standard Series	DVGW series	Customised Series						
		Min.	Max.				20	22	26	27	30	32	
"Aromatic" hydrocarbons	20	-20	+60					●					
Acetone and other ketones	20	-20	+60										●
Acetophenone	20	-20	+60										●
Acetylene - Acetone	20	-20	+60										●
Acetylene (gas)	20	-20	+60	●	●	●							
Alcohol (100%)	20	-20	Boiling										●
Aluminium (liquid suspension, thick)	40	-20	+90	●	●	●							
Amyl alcohol	20	-20	Boiling										●
Animal fats, greases	20	+5	+200		●	●			●				
Antifreeze or glycol (diluted)	40	-20	+40	●	●	●							
Argon (gas) Ar	20	-20	+60	●	●	●							
Barium - Hydroxide	20	-20	+40										●
Benzaldehyde	20	-20	+60										●
Benzene	20	-20	+60					●					
Benzyl alcohol	20	-20	Boiling					●					
Borax (pastes or solutions)	20	-20	+60										●
Brake fluids (automobile)	20	-20	+90										●
Bromochlorotrifluoroethane	20	-20	+60		●	●			●				
Butadiene (hydrocarbon)	20	-20	+60								●		
Butane	20	-20	+60	●	●	●							
Butanol	20	-20	Boiling					●					
Butyl alcohol	20	-20	Boiling					●					
Butylene (hydrocarbon)	20	-20	+60					●					
Carbon dioxide gas CO <sub>2</sub>	40	-20	+60	●	●								
Castor oil	40	-20	+90	●	●								
Compressed air	20	-25	+180					●					
Creosotes	20	-20	+60								●		
Cresols	20	-20	+60								●		
Crude oil	20	-20	+40				●						
Cutting oil	40	-20	+90	●	●								
Decalin (hydrocarbon, solvent)	20	-20	+60								●		
Detergents (solutions)	20	-20	+100										●
Diacetone alcohol	20	-20	Boiling										●
Diesel oils	40	-20	+90	●	●								
Di-Esters	20	-20	+90					●					
Di-Isobutylene	20	-20	+60								●		
Di-Pentane	20	-20	+60					●					

Ball Valves  
Industrial Valves

The above recommendations are given in good faith. However, since each application is different, it is advisable to undertake tests in actual working conditions.

# Ball Valves: Usage Chart

Chemical Description	Max. Pressure (bar)	Temperature °C		Universal and Light Series	Standard Series	DVGW Series	Customised Series						
		Min.	Max.				20	22	26	27	30	32	
Di-Pentene (solvents, varnish)	20	-20	+60					●					
Di-Phenyl-Oxide (thin detergents)	20	-20	+60								●		
Distilled water	40		+90	●	●	●							
Edible fats	20	+5	+200		●					●			
Edible oils	20	+5	+200		●					●			
Erytrene (see Butadiene)	20	-20	+60								●		
Ethane (gas) CH <sub>2</sub> CH <sub>3</sub>	20	-20	+60	●	●								
Ethane (hydrocarbon gas)	20	-20	+60								●		
Ethyl alcohol	20	-20	+60										●
Ethylene glycol (antifreeze) - see Glycols	20	-20	+120										●
Fatty alcohols	20	-20	Boiling					●					
Fuel oils	40	-20	+40	●	●	●							
Fuels-Diesels	40	-20	+40	●	●								
Gaseous oxygen (ambient air)	20	-20	+40									●	
Glycerine	20	-20	+40	●	●								
Glycol (for antifreeze, lubricants)	40	-20	+40	●	●								
Graphite in suspension in water, oils and greases	40	-20	+90	●	●								
Greases (from petroleum)	40	-20	+90	●	●								
Helium (gas)	20	-20	+60									●	
Heptanal	20	-20	+50	●	●								
Hexane (solvent)	20	-20	+60									●	
Hydraulic oils (petroleum-based)	40	-20	+90	●	●								
Hydrogen (gas)	20	-20	+60									●	
Inks	20	-20	+60								●		
Insecticides	20	0	+40	●	●	●							
Iso-Butane (aliphatic hydrocarbon)	20	-20	+60								●		
Iso-Octane	20	-20	+60								●		
Isopropyl alcohol	20	-20	Boiling										●
Krypton (gas) Kr	20	-20	+60	●	●	●							
Light water	40		+80	●	●	●							
Lighting gas	20	-20	+40			●							
Methane (gas) CH <sub>4</sub>	20	-20	+60	●	●	●							
Methanol	20	-20	Boiling										●
Methyl alcohol	20	-20	Boiling										●
Methylated spirit	40	-20	+40	●	●	●							
Mineral oils	40	-20	+90	●	●								
Natural gas	20	-20	+40			●							
Natural waxes (vegetable, beeswax, carnauba, Chinese, lignite)	40	-20	+90								●		
Neatsfoot oil	40	-20	+90	●	●	●							
Neon (Gas) Ne	20	-20	+60	●	●	●							
Nitrogen (gas) N <sup>2</sup>	40	-20	+90	●	●	●							
Oil (petroleum-based) and water emulsions	40	-20	+90	●	●	●							

The above recommendations are given in good faith. However, since each application is different, it is advisable to undertake tests in actual working conditions.

