

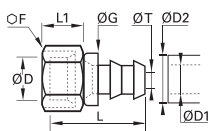



Self-Fastening Barb Connectors for NBR Hose

0132 Self-Fastening Barb Connector for Brass Compression Fitting

		ØD	ØD1	ØD2		F	G	L	L1	ØT	kg
		6	6.3	13	0132 06 56	12	16.5	32.5	12.5	4.8	0.010
		8	6.3	13	0132 08 56	14	16.5	29.5	11.5	4.8	0.015
		10	6.3	13	0132 10 56	19	16.5	30	14	4.8	0.028
		10	9.5	16	0132 10 60	19	19.5	34	14	7.5	0.030
		14	9.5	16	0132 14 60	24	19.5	35.5	15	7.5	0.050
		14	12.7	19	0132 14 62	24	23.5	39.5	15	10	0.054
		18	12.7	19	0132 18 62	30	23.5	41.5	17	10	0.090
		18	15.9	23	0132 18 66	30	27	50	17	13.5	0.090
		22	19.1	27	0132 22 69	36	30.5	56.5	17	16	0.128

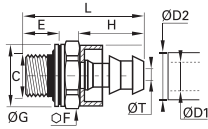

Polymer collar

0133..39 Self-Fastening Barb Connector with Bi-Material Seal, Male BSPP Thread

		ØD1	ØD2	C		E	F	G	H	L	ØT	kg
		6.3	13	G1/8	0133 56 10 39	5.5	13	14	20	31.5	4.8	0.012
		6.3	13	G1/4	0133 56 13 39	7	17	17	20	33.5	4.8	0.018
		9.5	16	G1/4	0133 60 13 39	7	17	17	24	37.5	7.5	0.022
		9.5	16	G3/8	0133 60 17 39	9.5	22	22	24	42.5	7.5	0.038
		12.7	19	G3/8	0133 62 17 39	9.5	22	22	28	46.5	10	0.045
		12.7	19	G1/2	0133 62 21 39	10.5	27	26	28	48.5	10	0.060
		15.9	23	G1/2	0133 66 21 39	10.5	27	26	36.5	57	13.5	0.064
		15.9	23	G3/4	0133 66 27 39	11.5	32	32	36.5	59	13.5	0.095
		19.1	27	G3/4	0133 69 27 39	11.5	32	32	43	65.5	16	0.111

Thread with bi-material seal and polymer collar.
Bi-material sealing washer part number 0139 can be found in Chapter 9.

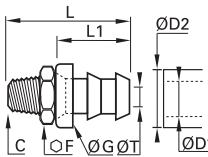
0134 Self-Fastening Barb Connector, Male BSPT Thread

		ØD1	ØD2	C		F	G	L	L1	ØT	kg
		6.3	13	R1/8	0134 56 10	14	16.5	32.5	20	4.8	0.015
		6.3	13	R1/4	0134 56 13	14	16.5	37	20	4.8	0.020
		9.5	16	R1/4	0134 60 13	14	19.5	41	24	7.5	0.022
		9.5	16	R3/8	0134 60 17	19	19.5	41.5	24	7.5	0.036
		12.7	19	R3/8	0134 62 17	19	23.5	45.5	28	10	0.038
		12.7	19	R1/2	0134 62 21	22	23.5	50	28	10	0.062
		15.9	23	R1/2	0134 66 21	22	27	58.5	36.5	13.5	0.056
		15.9	23	R3/4	0134 66 27	27	27	60.5	36.5	13.5	0.101
		19.1	27	R3/4	0134 69 27	27	30.5	67	43	16	0.108

Polymer collar

Self-fastening NBR hose is selected by nominal diameter; for example:

Barb Connector	O.D. (Tube)	Ø DN (Tube)	Self-Fastening NBR hose
0132 10 56	10	1/4	10..H 56...



Self-Fastening Barb Connectors for NBR Hose

This range of fittings is designed to meet the requirements of the automotive and robotics industries, combining as it does **optimum CNOMO manufacturing quality**, simple installation, reliable operation and a **long service life**.

Product Advantages

Perfect for Self-Fastening NBR Hose

- Quick and simple to install
- Compatible with the Parker Legris range of brass compression fittings
- Mechanical properties proven for use in industrial robotic installations
- Spark-resistant

Ergonomic and Time-Saving

- Fitting does not require lubrication or clamping, reducing assembly time
- Visual stop confirms installation is correct and improves operating safety
- Removal by cutting the tube
- The fitting can be re-used if necessary



Applications

- Welding Robots
- Pneumatics
- Compressed Air Systems
- Automotive Process
- Cooling

Technical Characteristics

Compatible Fluids	Coolants, compressed air						
Working Pressure	0 to 16 bar						
Working Temperature	0°C to +100°C (water) -20°C to +70°C (air)						
Tightening Torque, Type 0132	DN	6	8	10	14	18	22
	daN.m	0.7	1.5	1.8	3.5	6	7

Reliable performance is dependent upon the type of fluid conveyed and hose being used.

Component Materials

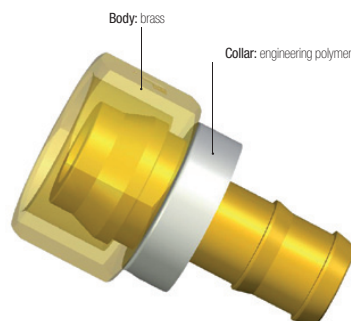

Silicone-free

Self-Fastening Hose Assembly Machine

Machine designed to assemble a barb connector and a self-fastening NBR hose.
Machine part number: **0650 00 00 05**



Tube Cutting and Positioning

Cut the hose square and position the barb connector on the mounting tool.

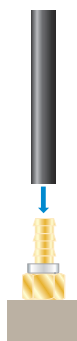

Press-Fitting the Tube

Activate the press-fit tool; connection is complete when the tube is fully home on the barb connector. This tool has been designed for use with 5 different diameters and is easy to operate.



Regulations

Industrial
 DI: 2002/95/EC (RoHS), 2011/65/EC
 DI: 97/23/EC (PED)
 RG: 1907/2006 (REACH)
 CNOMO: E07.21.115N