



ELECTRONIC, ELECTRIC, ANALOGUE AND IO-LINK SENSORS P8S SERIES



Table of Contents

P8S Sensors

Product Overview.....	4
Technical Data.....	5
Dimensions.....	6
Connection Type and Diagram.....	7
Ordering Data.....	8

P8S CPS Sensors

Product Overview.....	10 - 11
Technical Data.....	10 - 11
Ordering Data.....	10 - 11
Dimensions.....	10 - 11
Connection Type and Diagram.....	10 - 11

Mountings and Brackets.....	13
Connectors and Cables.....	14

P8S Pneumatic Sensors

Product Overview.....	15
Dimensions.....	15
Mounting and Bracket.....	15



If you have questions about the products contained in this catalog, or their applications, please contact:
Parker Hannifin EMEA Sàrl European Headquarters
parker.com/msgc

Extra care is taken in the preparation of this literature, but Parker is not responsible for any inadvertent typographical errors or omissions. Information in this catalog is only accurate as of the date of publication. For a more current information base, please consult the division web site at parker.com/msgc.

**Important**

Before attempting any external or internal work on the cylinder or any connected components, make sure the cylinder is vented and disconnect the air supply in order to ensure isolation of the air supply.

**Note**

All technical data in this catalogue are typical data only.
Air quality is essential for maximum cylinder service life (see ISO 8573).

**WARNING – USER RESPONSIBILITY**

FAILURE OR IMPROPER SELECTION OR IMPROPER USE OF THE PRODUCTS DESCRIBED HEREIN OR RELATED ITEMS CAN CAUSE DEATH, PERSONAL INJURY AND PROPERTY DAMAGE.

- This document and other information from Parker-Hannifin Corporation, its subsidiaries and authorized distributors provide product or system options for further investigation by users having technical expertise.
- The user, through its own analysis and testing, is solely responsible for making the final selection of the system and components and assuring that all performance, endurance, maintenance, safety and warning requirements of the application are met. The user must analyze all aspects of the application, follow applicable industry standards, and follow the information concerning the product in the current product catalog and in any other materials provided from Parker or its subsidiaries or authorized distributors.
- To the extent that Parker or its subsidiaries or authorized distributors provide component or system options based upon data or specifications provided by the user, the user is responsible for determining that such data and specifications are suitable and sufficient for all applications and reasonably foreseeable uses of the components or systems.

SALE CONDITIONS

The items described in this document are available for sale by Parker Hannifin Corporation, its subsidiaries or its authorized distributors. Any sale contract entered into by Parker will be governed by the provisions stated in Parker's standard terms and conditions of sale (copy available upon request).

P8S ELECTRONIC AND REED SENSORS

The P8S Series magnetic cylinder sensor enables quick, precise and contactless sensing of the piston's position in cylinders. It is easy to mount, can be used in numerous applications and offers an outstanding price-performance ratio.

Product Overview

As the term magnetic switch suggests, these are operated by magnetic fields; another description widely used is magnetic „SENSOR“. As our eyes sense change of light, our ears sense the change of sound, magnetic sensors / switches sense the change of magnetic flux in pneumatic and hydraulic cylinders. When magnetic sensors sense a magnetic field it will give a switching signal, through a control circuit, allowing sensing or control operation to be achieved.

Because of the characteristics of magnetic sensors they can sense a change of magnetic field relative to the position of the magnet, such as in a pneumatic or hydraulic cylinder, whereby the magnet is attached to a moving piston and thus the position of the moving part (ie Piston) can be detected.

The magnet is mounted on the piston of the cylinder and thus moves with the piston.

The magnetic sensor (switch) is fixed either directly to the cylinder or with an additional mounting bracket. When the piston (magnet) moves to the

position under a magnetic sensor, the switch will operate due to the change of the magnetic field and give a switching signal.

Thus the position of the piston can be identified and a resulting signal generated to continue the sequence of a circuit.

Magnetic sensors available can be classified into two different groups, they are sensors with contacts which are called mechanically operated or reed sensors and the other type is sensors without contacts and are called solid state type or electronic.

Parker P8S Series sensors are suitable for use with a large range of Sensors. They can either be inserted directly into the cylinder tube extrusion or mounted using additional brackets. For direct mounting the sensor is positioned within the cylinder sensor groove, offering mechanical protection, then securely clamped into position by a simple turn of a screw. For other cylinder versions there are a number of optional sensors brackets that clamp to the cylinder and offer other mounting



positions. To easy installation there are several cable lengths available with either M8 connector or flying lead. The electronic sensors are "Solid State", i.e. they have no moving parts. They are provided with short-circuit protection and transient protection as standard. The built-in electronics make the sensors suitable for applications with high on and off switching frequency where long service life is required.

Please note that for low temperature applications sensors are normally specified for full performance down to -30°C only. High temperature cylinders do not have a magnetic piston and therefore cannot be used with sensors.

TECHNICAL DATA

Square body design, insert straight in T-slot, screw 1/4 turn

	Electronic PNP NPN	Electric Reed
Cylinder type:	Profile with T-slot	
Cylinder type with adaptor:	Profile with S-slot (dovetail) Tie rods Round cylinders	
Installation:	Quarter turn, fixed by allen key 2.5 mm or flathead screwdriver	
Housing length:	29.5 mm 10 - 30 V DC	29.5 mm 5 - 30 V AC/DC
	24 mm NAMUR	29.5 mm 5 - 120 V AC/DC
	29.5 mm ATEX	32.5 mm 5 - 230 V AC/DC
Output Type:	PNP NPN	Reed
Switching (on/off) switching frequency:	± 1,000 Hz	± 400 Hz
Output Function:	Normally Open (NO) Normally Closed (NC) 3-wire	Normally Open (NO) Normally Closed (NC) 2-wire Normally Open (NO) 3-wire
Enclosure rating:	IP67	
Supply Voltage:	10 to 30 V DC	
	8.2 to 20 V DC (NAMUR 1GD) 10 to 26 V DC (ATEX 3GD)	5 to 30 5 to 120 5 to 230 V AC/DC 2-wire, 3-wire depending on type
Power consumption:	≤ 8 mA	
	≤ 10 mA (NAMUR, ATEX)	
Voltage drop:	≤ 2 V	
	≤ 2.2 V (NAMUR, ATEX)	≤ 3.5 V 2-wire ≤ 0.1 V 3-wire
Continuous output current I _a :	≤ 100 mA	
	≤ 60 mA (NAMUR) ≤ 50 mA (ATEX)	≤ 500 mA (DC) ≤ 300 mA (AC)
Switching capacity:	-	≤ 6 W
Protection class:	III	
		III II 2-wire depending on type III 3-wire
Response sensitivity:	2.6 to 3.3 mT	
	2.8 mT (NAMUR, ATEX)	2.1 to 3.4 mT
Overrun distance:	10 mm	
	9 mm (NAMUR, ATEX)	-
Hysteresis:	≤ 0.8 mT	
	≤ 0.5 mT (NAMUR, ATEX)	-
Repeatability:	≤ 0.1 mT	
Reverse polarity protection:	Yes	No 2-wire
	-	Yes 3-wire
Short circuit protection:	Yes	-
Power-up pulse protection:	Yes (NAMUR, ATEX)	-
Ambiant operating temperature range:	-30 to +80 °C (PUR cable) -30 to +70 °C (PVC cable)	
	-25 to +80 °C (NAMUR 1GD) -20 to +50 °C (ATEX 3GD)	
Shock and vibration resistance:	30 g 11 ms / 10 ... 55 Hz, 1 mm	
EMC:	According to EN 60947-5-2	
International standard:	CE C UL US RoHs Ex IEC IEC Ex	
Housing material:	Plastic polyamid PA12	
Screw material:	Stainless steel	
Cable material:	PUR (Polyurethane) PVC (Polyvinyl Chloride)	
Conductor cross-section:	0.14 mm ² 0, 12 mm ² depending on type 0.14 mm ² (NAMUR, ATEX)	
Indication LED colour:	Yellow, no LED reed NC	
Connector:	M8R (knurled nuts) None (Flying lead)	

DIMENSIONS in mm (inch)

PNP, NPN Output 10 to 30 V DC

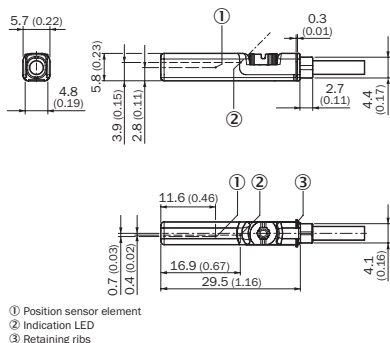

Reed Output 5 to 230 V AC/DC

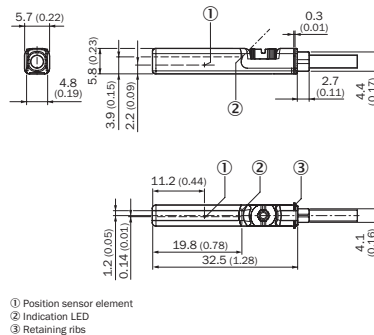

Reed Output 5 to 30 V AC/DC

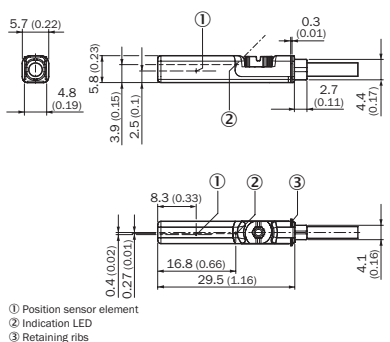

Reed Output 5 to 120 V AC/DC

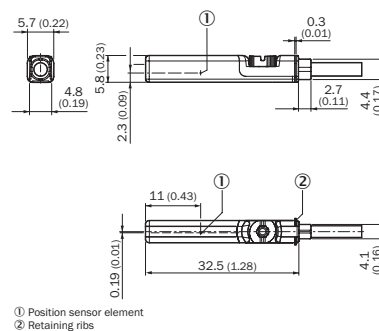

NAMUR 1G, 1D

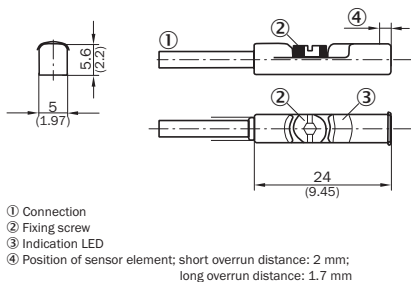

Connector M8R

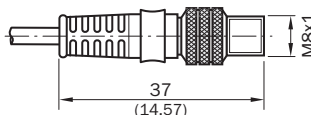

Installation

Square body design, Insert straight in T-slot, screw 1/4 turn

With Adaptor in S-Dovetail Slot

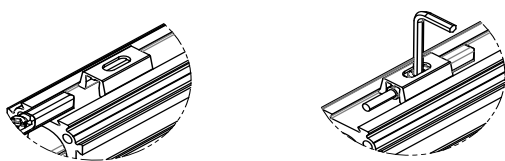

Without Adaptor directly in T-Slot

Put-in straight

Screw 1/4 turn

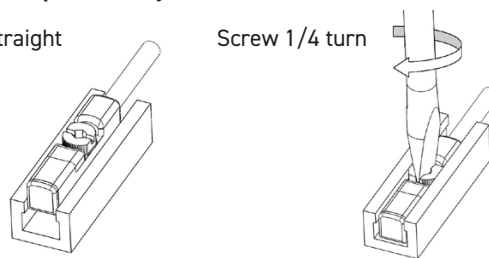

Note:
The adaptor is delivered with each sensor.

CONNECTION TYPE AND DIAGRAM

PNP NO

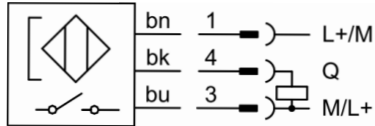

PNP NC

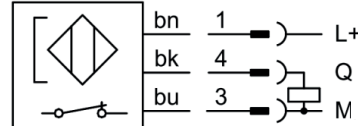

NPN NO

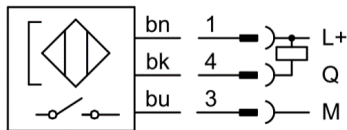

NPN NC

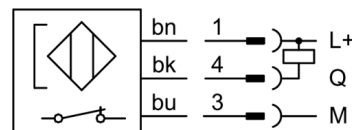

Reed NO 3-wire

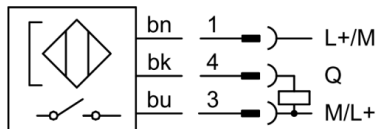

bn: brown
 bk: black
 bu: blue
 Q: load
 M: Mass
 L+: Power

Reed NO 2-wire

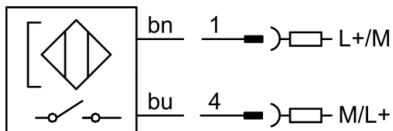

Reed NC 2-wire

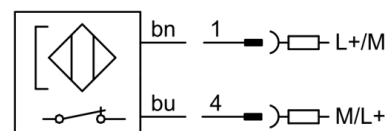

NAMUR NO ATEX 1G, 1D

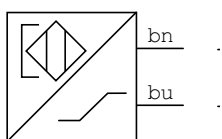

PNP NO ATEX 3G, 3D

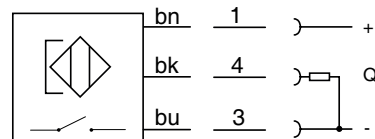

Pin assignment, M8 with knurled nut

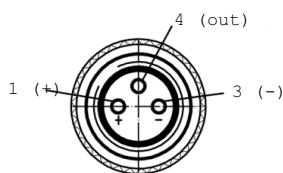

Flying leads

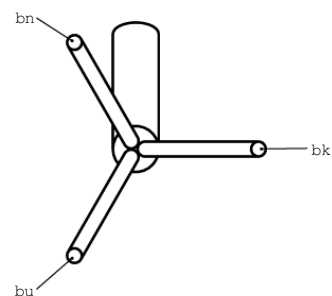

ORDERING DATA

Square body design, insert straight in T-slot, screw 1/4 turn

Output, Function, Cable & Supply Voltage	Order Code	Order Code	Order Code
With flying leads, PUR cable IP67	0,3 metre	3 metre	10 metre
Electronic PNP-NC, with LED, 3-wire, 10-30 V DC	N/A	P8SAGQFAX	P8SAGQFDX
Electronic PNP-NO, with LED, 3-wire, 10-30 V DC	N/A	P8SAGPFAX	P8SAGPFDX
Electronic NPN-NC, with LED, 3-wire, 10-30 V DC	N/A	P8SAGMFAX	P8SAGMFDX
Electronic NPN-NO, with LED, 3-wire, 10-30 V DC	N/A	P8SAGNFAX	P8SAGNFDX
Electric Reed-NO, with LED, 3-wire, 5-30 V AC/DC	N/A	P8SAGSFAX	P8SAGSFDX
Electric Reed-NO, with LED, 2-wire, 5-30 V AC/DC	N/A	P8SAGRFAFAX	N/A
Electric Reed-NO, with LED, 2-wire, 5-230 V AC/DC	N/A	N/A	P8SAGRFDX2
Electric Reed-NC, No LED, 2-wire, 5-120 V AC/DC	N/A	N/A	P8SAGEFRX1
Electric Reed-NC, No LED, 2 wire, 5-30V AC/DC	N/A	N/A	P8SSAGEFRX
<i>Weight: 35 g 3 metre, 105 g 10 metre</i>			
With flying leads, PVC cable IP67	0,3 metre	3 metre	10 metre
Electric Reed-NO, with LED, 3-wire, 5-30 V AC/DC	N/A	P8SAGSFLX	N/A
Electric Reed-NO, with LED, 2-wire, 5-120 V AC/DC	N/A	P8SAGRFLX1	N/A
Electric Reed-NO, with LED, 2-wire, 5-230 V AC/DC	N/A	P8SAGRFLX2	N/A
Electronic PNP-NC, with LED, 3-wire, 10-30 V DC	N/A	P8SAGQFLX	N/A
Electronic PNP-NO, with LED, 3-wire, 10-30 V DC	N/A	P8SAGPFLX	P8SAGPFTX
Electric Reed-NO, with LED, 2-wire, 5-120 V AC/DC	N/A	N/A	P8SAGRFTX1
Electric Reed-NO, with LED, 3-wire, 10-30 V AC/DC	N/A	N/A	P8SAGSFTX
<i>Weight: 35 g 3 metre, 105 g 10 metre</i>			
With M8 knurled screw, PUR cable IP67	0,3 metre	3 metre	10 metre
Electronic PNP-NC, with LED, 3-wire, 10-30 V DC	P8SAGQCHX	N/A	N/A
Electronic PNP-NO, with LED, 3-wire, 10-30 V DC	P8SAGPCHX	N/A	N/A
Electronic NPN-NC, with LED, 3-wire, 10-30 V DC	P8SAGMCHX	N/A	N/A
Electronic NPN-NO, with LED, 3-wire, 10-30 V DC	P8SAGNCHX	N/A	N/A
Electric Reed-NO, with LED, 3-wire, 5-30 V AC/DC	P8SAGSCHX	N/A	N/A
Electric Reed-NC, No LED, 2-wire, 5-30 V AC/DC	P8SAGECNX	N/A	N/A
Electric Reed-NO, with LED, 2-wire, 5-30 V AC/DC	P8SAGRCHX	N/A	N/A
<i>Weight: 15 g 0,3 metre</i>			
ATEX 3G, 3D, IP67	3 metre	5 metre	10 metre
Electronic PNP-NO, with LED, 3-wire, 10-26 V DC, PUR	P8SAGPFAXS	N/A	N/A
<i>Weight: 35 g 3 metre, 55g 5 metre, 105 g 10 metre</i>			
NAMUR 1G, 1D, IP67	3 metre	5 metre	10 metre
NAMUR-NO, with LED, 2-wire, 8,2-20 V DC, PVC	N/A	P8SAGDFMXW *	P8SAGDFTXW *
<i>Weight: 35 g 3 metre, 55g 5 metre, 105 g 10 metre</i>			

Note:

-30 to +80 °C (PUR cable) | -30 to + 70 °C (PVC cable) | -25 to +80 °C (NAMUR 1GD) | -20 to +50 °C (ATEX 3GD)

All sensors are with an adaptor for S-dovetail Parker type OSP grooves.

* with an aluminium adaptor



P8S CONTINUOUS POSITION SENSORS

Product Overview

P8S Continuous Position Sensors detect continuously the position of the piston of pneumatic cylinders using a direct, non-contact technology along the length of the sensors, measuring ranges from 32 to 256 mm. They can be mounted in T-slots without the need for additional accessories for cylinders built with common T-slot dimensions. Mounting on other cylinder types ie round cylinders type is possible with adaptors. The sensor settings can be adjusted during installation and during operation later on, using a teach button or, depending on the variant, using IO-Link.

The sensors continuously supply data via analogue outputs or IO-Link.

Analogue position sensors, for current or voltage, have a voltage output of 0 V ... 10 V as well as a current output of 4 mA ... 20 mA. It enables flexible machine concepts making it possible to solve tasks in areas such as quality monitoring and process control in conjunction with pneumatic cylinders. This continuous transfer of position data upgrades the functionality of the pneumatic cylinders by making them more intelligent and as a result, more versatile.



Many applications require more than just end of stroke sensing of an actuator, but traditional methods of continuous sensing are expensive to implement. Parker's CPS (Continuous Position Sensing) series of the P8S sensor family enables quick, precise and contactless continuous position sensing of a piston in standard Sensors. This offers an outstanding price/performance ratio.

Technical Data	
Cylinder type:	Profile with T-slot
Installation:	Drop in, fixed by allen key 1.5 mm
Measuring range:	32 to 256 mm depending on type ¹⁾
Housing length:	45 to 269 mm depending on type
Output Function:	Analogue IO-Link
Analogue output (voltage):	0 to 10 V -
Analogue output (current):	4 to 20 mA -
Teach-in:	Yes
Enclosure rating:	IP 67 (according to EN 60529)
Supply Voltage: ²⁾	15 to 30 V DC
Power consumption: ³⁾	<= 22 mA (analogue) <= 25 ma (IO-Link)
Max load resistance: ⁴⁾	<= 500 Ω
Min load resistance: ⁵⁾	<= 2 kΩ
Protection class:	III
Time delay before availability:	1.5 s
Required magnetic field sensitivity:	3 mT / 2 mT (Analogue) 3 mT (IO-Link)
Resolution: ⁶⁾	0.03% full scale range (max >=0.05 mm)
Linearity error: ⁷⁾	0.3 mm
Repeat accuracy: ⁸⁾	0.06% full scale range (>= 0.1 mm)
Sampling rate: ⁹⁾	1 ms
Indication LED colour:	Yellow (Analogue)
Reserve polarity protection:	Yes (Analogue)
Short circuit protection:	Yes (Analogue)
Ambiant operating temperature range:	-20 to +70 °C (PUR cable)
Shock and vibration resistance:	30 g 11 ms / 10 ... 55 Hz, 1 mm
EMC: ¹⁰⁾	According to EN 60947-5-2
International standard:	CE C UL US CCC (not applicable) RoHs IO-Link
UL file No:	On request
Housing material:	Plastic polyamid PA12
Screw material:	Stainless steel
Cable material:	PUR (Polyurethane)
Conductor cross-section:	0.08 mm ²
Connector:	M12 (IO-Link) or M8 (Analogue)

- 1) ± 1 mm
- 2) Reverse-polarity protected, operation in short-circuit protected network: max. 8 A.
- 3) Without load
- 4) Power output, at 24 V
- 5) Voltage output
- 6) FSR: Full Scale Range; max. measuring range.
- 7) At 25 °C, linearity error (maximum deviation) depending on response curve and minimal deviation function.
- 8) At 25 °C, repeatability magnet movement in one direction.
- 9) Only in standard mode, not in IO-Link mode.
- 10) The analogue measured value can deviate under transient conditions.

CONTINUOUS POSITION SENSING

Analogue signal or IO-Link communication for linear cylinders many applications require more than just end of stroke sensing of an actuator, but traditional methods of continuous sensing are expensive and difficult to implement. Parker's CPS series of the P8S sensor family enables quick, easy, precise, and contactless position sensing of a piston. This can be installed on a standard linear actuator and offers an outstanding price to performance ratio.

Product Features:

Continuous position sensing

- IO-Link communication with M12 connector
- No modification to the actuator
- Analogue version with M8 connector
- 5 sizes with sensing ranges from 32 mm to 256 mm
- IP67 design suitable for any industrial application
- Yellow teach button for easy set-up

Technical specification:

1 ms sampling rate
 0.03% full scale resolution
 0.06% full scale repeatability
 0.3 mm Linearity error

How it works:

The CPS product detects the position of an actuator via the magnet on the piston. The sensor settings can easily be adjusted during installation using the yellow teach button or during operation over the IO-Link communication. This upgrades the functionality of the pneumatic actuator by making it more intelligent and versatile in support of the Industry 4.0 initiative.

How it connects:

Analogue version has a M8 connector and a voltage output of 0-10V as well as a current output of 4-20mA. IO-Link version has a M12 connector and transmits position via 2 bytes of process input data and also allows for parameter control of measuring range and locking of the teach button. It can be controlled by Class A or Class B IO-Link Masters.



How it installs:

The Parker CPS requires the use of a magnetic piston. The product will fit T-slot cylinders without any additional mounting hardware.

Without Adaptor:

Direct drop-in T-slot
 T-slot dimensions [mm ± 0.1]

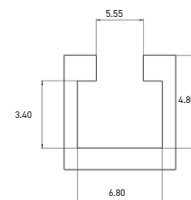

- 1) Pivot sensor into the slot
- 2) Teach the CPS unit the desired measuring range
- 3) Tighten set screws

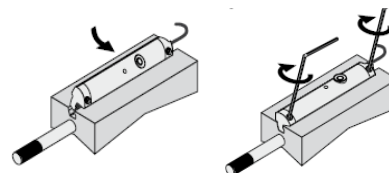

DIMENSIONS in mm (inch)

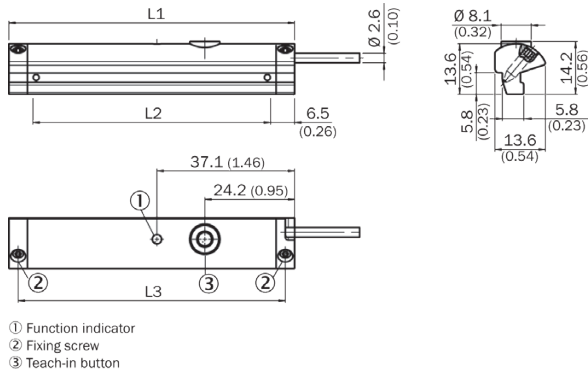

			Order Code	
L1	L2 *	L3	Analogue	IO-Link
45	32	40	P8SAGACHA	P8SAGHMHA
77	64	72	P8SAGACHB	P8SAGHMHB
141	128	136	P8SAGACHD	P8SAGHMHD
205	192	200	P8SAGACHF	P8SAGMHMF
269	256	264	P8SAGACHH	P8SAGMHMH

*L2 equal to the measuring range

Note:

PUR cable with M12 (IO-Link) or M8 (Analogue) male connector knurled nut, 4-pin, 0,3 meter length.
Please consult for measuring range 96, 160 & 224 mm.

Connection type and diagram

IO Link version

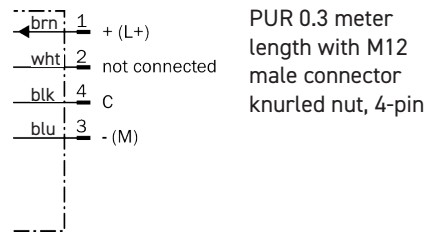

Analogue version

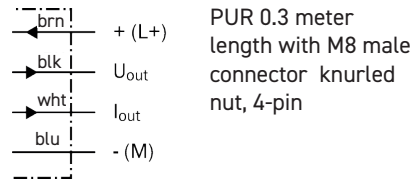

Ordering Data

Drop in in T-slot

Output	Measuring length	Configuration Option	Order Code	Weight [g]	For product series
Analogue	32 mm	Teach Button	P8SAGACHA	16	With T-slot groove *
	64 mm		P8SAGACHB	26	
	128 mm		P8SAGACHD	46	
	192 mm		P8SAGACHF	66	
	256 mm		P8SAGACHH	86	
IO-Link	32 mm	Teach Button or IO-Link parameter	P8SAG HMHA	20	With T-slot groove *
	64 mm		P8SAGHMHB	30	
	128 mm		P8SAGHMHD	50	
	192 mm		P8SAGMHMF	70	
	256 mm		P8SAGMHMH	90	

* Required magnetic field sensitivity: 3mT / -2 mT (Analogue) / 3mT (IO-Link)

Note: PUR cable with M12 (IO-Link) or M8 (Analogue) male connector knurled nut, 4-pin, 0,3 meter length.
Please consult for measuring range 96, 160 & 224 mm.

MOUNTINGS AND BRACKETS

For products series	Oder code	Weight [g]
P1F Tie rods, VRS/VRA	P8S-TMA0X	65
T-Slot OSP Ø 10	8872FIL	3
T-Slot P Series Ø 16	8865FIL	4
T-Slot P Series Ø 25-80	8866FIL	5
Round cylinder Ø10-25	P8S-TMC01	27
Round cylinder Ø 32-63	P8S-TMC02	29
S-Dovetail OSP, pack of 10	P8S-TMA09	10

Ambient temperature -30 to +80 °C

Pack of 10 consists of 10 plastic adaptors for S-Dovetail grooves.

All mountings can be moved on the cylinder body before screwing in place and then putting sensors in the slots.

Dimensions in mm (inch)

P8S-TMC01, 02

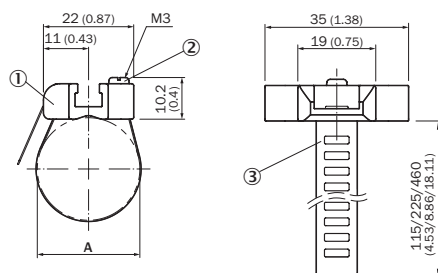

- 1 Sensor adaptor
- 2 Fixing screw
- 3 Strap

Oder code	A [mm]	
P8S-TMC01	8 to 25	Clamping ring in nickel silver, screw in stainless steel, sensor mounting zinc diecast
P8S-TMC02	32 to 63	

P8S-TMA0X

(Zinc diecast, zinc plated screws.)

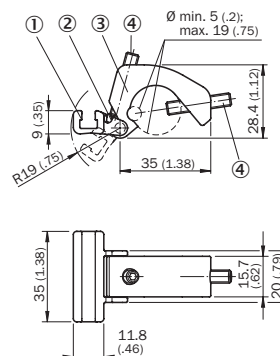

- 1 Sensor adaptor with T-Slot
- 2 Fixing for cable < Ø 3.2 mm (0.126 inch)
- 3 Cylinder adaptor
- 4 Mounting screws M5

MALE CONNECTORS FOR CONNECTING CABLES

Cable connectors for producing your own connecting cables.

The connectors can be quickly attached to the cable without special tools. Only the outer sheath of the cable is removed.

The connectors are available for M8 screw connector and meet protection class IP65.

Technical Data	
Operating voltage:	max. 32 V AC/DC
Operating current per contact:	max. 4 A
Connection cross section:	0.25... 0.5 mm ² (conductor diameter min 0.1 mm)
Protection class:	IP65 and IP67 when plugged and screwed down (EN 60529)
Temperature range:	- 25... + 85°C

Connector	Weight [kg]	Order Code
M8 screw connector		P8CS0803J
M12 screw connector	0.022	P8CS1204J



Cables to extend cable sensor lengths with M8*

Description	Order Code	Weight [g]	For Product Series
Cable flex PVC 3 meter with 8mm snap-in connector / flying leads	9126344341	70	P8S Sensors with M8
Cable flex PVC 10 meter with 8mm snap-in connector / flying leads	9126344342	210	P8S Sensors with M8
Cable PUR 3 meter with 8mm snap-in femelle connector / flying leads	9126344345	70	P8S Sensors with M8
Cable flex PUR 10 meter with 8mm snap-in connector / flying leads	9126344346	210	P8S Sensors with M8
Cable PVC 2.5 meter with M8 screw connector / flying leads	KC3102	60	P8S Sensors with knurled M8
Cable PVC 5 meter with M8 screw femelle connector / flying leads	KC3104	120	P8S Sensors with knurled M8

*Note: not applicable for P8S CPS Sensors as no cable available

PNEUMATIC SENSOR FOR TIE-RODS CYLINDERS

An ideal solution where a direct pneumatic signal is wanted from a cylinder sensor to a pneumatic control system, for example. This could be a machine or device in which only compressed air is available, and an electricity supply to normal cylinder sensors would involve serious problems or considerable expense.

Function:

Non-contacting sensing of a pneumatic cylinder, triggering an output signal (conn. 2) from the integrated 3/2 NC valve, which is activated by a magnetic field or iron core and has a return spring. If more than one sensor is used with a cylinder there must be a distance of at least 20 mm between sensors to prevent them influencing each other. To avoid interference, there must be a minimum spacing of 15 mm to steel details. The outlet (conn. 3) must not be blocked or restricted as this can impair the function of the sensor. The sensor is fastened to the cylinder using the special sensor fixing.

Technical data:

Working pressure: min 2 to max 6 bar
 Temperature: -15 to +60 °C
 Air quality: 3.4.3 to ISO 8573-1 (must be oil free)
 Function: 3/2 NC valve
 Flow: 40 Nl per minute
 Connection: for plastic pipe with 2,5-3 mm internal diameter

Activation distance: for magnet: min 9 mm
 Activation distance: for Fe: approx. 2 mm
 Repetition accuracy: +/- 0.2 mm
 Cylinder velocity: max 1 m/s (depends on magnetic field, interference from steel in environment, signal length requirement from control system....)

Distance between sensors: min 20 mm
 Distance from sensor to steel details: min 15 mm
 Fixing: with sensor fixing or with an M4 thread in case
 Sensing: non-contacting (also through a wall of non-magnetic material)

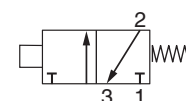

Description	Weight [kg]	Order code
Pneumatic sensor	0.02	P8S-A34X
Cylinder fixing bore Ø32 to Ø125 mm	0.01	P8S-AMA1

Dimensions (mm)

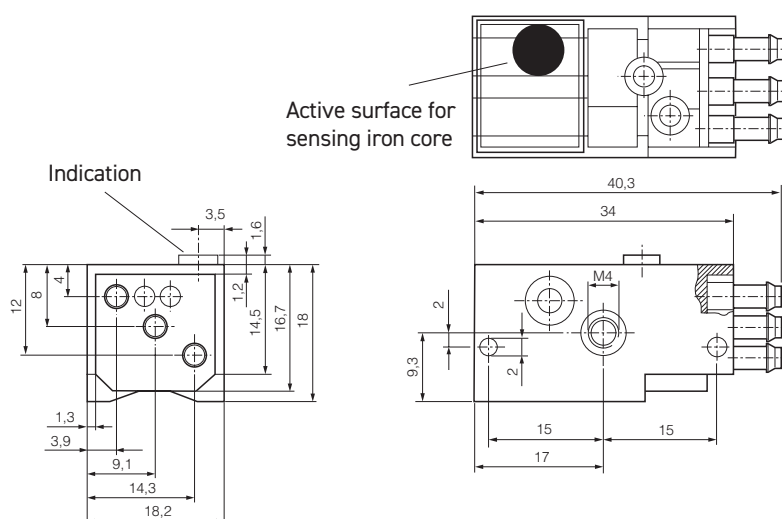

Cylinder fixing - Tie-Rods Cylinders Ø 32 to 100 mm

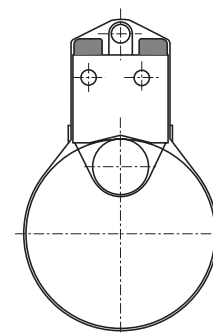

Parker Hannifin Corporation
Motion Systems Group Europe
Parker Hannifin EMEA Sàrl European Headquarters
La Tuilière 6 Etoy
Switzerland CH-1163
www.parker.com

PDE2815TCUK 05/2024

Your Local Authorized Parker Distributor

© 2024 Parker Hannifin Corporation

