

AIR PREPARATION SYSTEM LOCKOUT VALVES

with or without soft start
1/4 to 2 Body Ports



PNDE3003TCUK

Lockout Valves

Parker is protecting your most valuable assets	3
Lockout valves applications & mounting	4
LV, LVSS Series	5-7
EZ Series with soft start	8-9
Sales Guide	10-11



WARNING – USER RESPONSIBILITY

FAILURE OR IMPROPER SELECTION OR IMPROPER USE OF THE PRODUCTS DESCRIBED HEREIN OR RELATED ITEMS CAN CAUSE DEATH, PERSONAL INJURY AND PROPERTY DAMAGE.



- This document and other information from Parker-Hannifin Corporation, its subsidiaries and authorized distributors provide product or system options for further investigation by users having technical expertise.
- The user, through its own analysis and testing, is solely responsible for making the final selection of the system and components and assuring that all performance, endurance, maintenance, safety and warning requirements of the application are met. The user must analyze all aspects of the application, follow applicable industry standards, and follow the information concerning the product in the current product catalog and in any other materials provided from Parker or its subsidiaries or authorized distributors.
- To the extent that Parker or its subsidiaries or authorized distributors provide component or system options based upon data or specifications provided by the user, the user is responsible for determining that such data and specifications are suitable and sufficient for all applications and reasonably foreseeable uses of the components or systems.

SALE CONDITIONS

The items described in this document are available for sale by Parker Hannifin Corporation, its subsidiaries or its authorized distributors. Any sale contract entered into by Parker will be governed by the provisions stated in Parker's standard terms and conditions of sale (copy available upon request).



Parker is protecting your most valuable assets...

 www.osha.gov Standard 1910.147	<ul style="list-style-type: none"> • This applies to the servicing and maintenance of a machine or equipment. • Any new, replacement, repair, or renovation to a machine must include an energy isolation device that can accept a lock out device. • Lock out devices should not be used for any other purposes • Verification of energy isolation is required
 Standard Z244	<ul style="list-style-type: none"> • This applies to all machines • Lockout / tagout is the primary method of hazardous energy control • Machines shall be designed, manufactured, supplied, and installed with energy isolating devices
	<ul style="list-style-type: none"> • B11.0 applies to a broad range of machines, B11.TR6 is specific to machine tools, and B155.1 is specific to packaging and converting machines • Energy isolating device shall: <ul style="list-style-type: none"> - Be capable of being locked in the OFF position only - Be easy to operate - Have an exhaust port equal or greater than its supply port - Have a pressure indicator that is visible to an operator to verify line is relieved of pressure

...By offering the best in pneumatic safety for machine maintenance:



Traditional Ball Valve

- Not a dedicated energy isolation device** ✘
- Not a full exhaust port** ✘
- No verification of line exhaust** ✘
- Can be locked ON** ✘
- Not easily identifiable** ✘



Parker Solution

- ✓ **Dedicated energy isolation device**
- ✓ **Full exhaust port**
- ✓ **Verification of line exhaust**
- ✓ **Only lockable in OFF position**
- ✓ **Easily identifiable**

Energy Isolation Safety Function

The Lockout valve is used to block the supply and remove the downstream pressure from the circuit or machine and allow the worker to lockout the pneumatic energy for safe machine access.

Applications

Lockout valves are installed in pneumatic drop legs, or individual pneumatic control lines (see Figure 1). In accordance with OSHA procedures, EZ valves are used during maintenance and service procedures of pneumatically (air) operated equipment. Prior to servicing, the red handle is pressed inward, blocking pressure and relieving all downstream air pressure. A padlock is installed through the locking hasp, preventing accidental actuation during the maintenance procedure. Following maintenance, the padlock is removed and the red handle is pulled outward, gradually returning air pressure to the system. (For complete Lockout / Tagout procedures, consult OSHA Standard 29 CFR Part 1910 in U.S. Federal Register/Vol. 54 No. 169, Friday, September 1, 1989 / Page 36644.)

Mounting

Valves can be inline mounted or surface mounted using the two mounting holes provided in the valve body. Mount valves in plain view with the handle oriented for accessibility.

Placement of Lockout Device

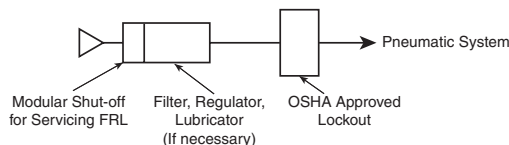
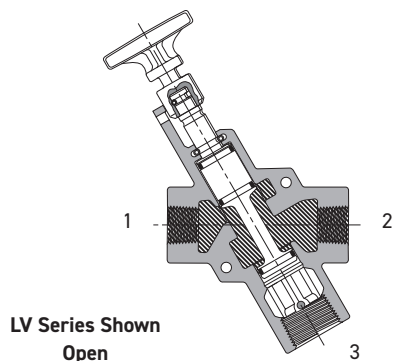

Figure 1.

LV / LVSS Operation

Normal Machine Operation - Valve Open

With the handle pulled outward. Inlet Port 1 is open to outlet Port 2. Exhaust Port 3 is blocked.



Lockout Operation - Valve Closed

With the handle pushed inward. Inlet Port 1 is blocked. Outlet Port 2 is open to Exhaust Port 3.

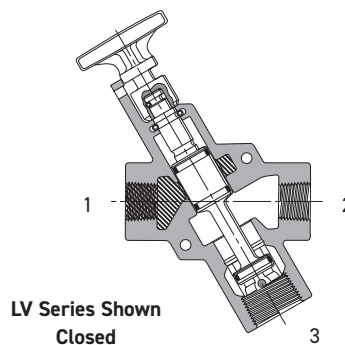

EZ Operation

Normal Machine Operation - Valve Open

When the red handle is pulled outward, the adjustable needle valve (accessed through the top of the handle) setting determines the rate of pressure buildup. When downstream pressure reaches the full flow described in the specifications below, Inlet Port 1 is open to outlet Port 2. Exhaust Port 3 is blocked.

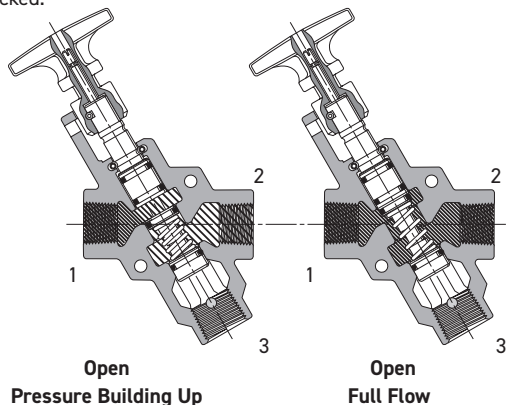

Lockout Operation - Valve Closed

When the red handle is pushed inward, the Inlet Port 1 is blocked. Downstream air is exhausted through Exhaust Port 3.

LV / LVSS Series

Lockout valves are installed in pneumatic drop legs, or individual pneumatic control lines. In accordance with OSHA procedures, lockout valves are used during maintenance and service procedures of pneumatically (air) operated equipment.

- Used for compliance with OSHA 29 CFR part 1910
- 1/4" to 2" pipe sizes BSPP, SS LV only NPT
- Yellow cast aluminum body with red handle or stainless steel (NACE MR0175 / ISO 15156)
- Inline or surface mountable
- Built in port for pressure verification to meet ANSI B11 and PMMI B155 requirements
- Fluorocarbon slipper seals for easy shifting, even after long periods of inactivity

Material specifications

Description	LV	LVSS
Body:	Cast aluminum alloy	Stainless steel
Handle:	Plastic	Stainless steel
Spool:	Aluminum	Stainless steel
Seals:	Carboxylated nitrile	Fluorocarbon
Detent spring:	Stainless steel	Stainless steel
Grease:	Magnalube G [†]	Magnalube G [†]

[†] Trademark Magnalube

Operating information

Operating pressure:	LV	LVSS
Compact	1 to 10 bar	-
Standard	1 to 20 bar	1 to 20 bar
High flow	1 to 20 bar	-
Operating temperature:	+4°C + 80°C	-1°C to +80°C
Operating media: Clean, dry, compressed air (5 micron)		

Safety Category Cat.1 PL b.

Compact

	Port In/Out	Port Exhaust	dm ³ /s In/Out	dm ³ /s Exhaust	Wt (kg)	Part Number BSPP *
	1/4	3/8	20	19	0,41	LV2B3B
	3/8	3/8	29	29	0,41	LV3B3B

Standard

	Port In/Out	Port Exhaust	dm ³ /s In/Out	dm ³ /s Exhaust	Wt (kg)	Part Number BSPP *
	3/8	3/4	51	39	0,90	LV3B6B
	1/2	3/4	77	43	0,90	LV4B6B
	3/4	3/4	89	44	0,90	LV6B6B
	3/4	1-1/4	142	97	1,45	LV6BAB
	1	1-1/4	179	103	1,45	LV8BAB
	1-1/4	1-1/4	208	105	1,45	LVABAB

High Flow

	Port In/Out	Port Exhaust	dm ³ /s In/Out	dm ³ /s Exhaust	Wt (kg)	Part Number BSPP *
	1-1/2	2	363	550	3,72	LVBBCB
	2	2	437	565	3,72	LVCBCB

Stainless Steel

	Port In/Out	Port Exhaust	dm ³ /s In/Out	dm ³ /s Exhaust	Wt (kg)	Part Number NPT *
	1/4	1/4	23	22	1,72	LV2N2BSS
	3/8	1/2	63	68	2,72	LV3N4BSS
	1/2	1/2	63	68	2,72	LV4N4BSS
	3/4	1	155	184	5,90	LV6N8BSS
	1	1	155	184	5,90	LV8N8BSS
	1-1/2	2	423	487	15,90	LVBNCBSS
	2	2	423	487	15,90	LVCNCBSS

NOTE: Exhaust flow rates calculated using inlet pressure 100 psig (6.7 bar), pressure drop 5 psi (0.34 bar), air temp 68°F (20°C), and 36% relative humidity.

* Indicator air port is NPT thread

Most popular.

LV Series, Exhaust Port - Compact, Standard, High Flow

Compact

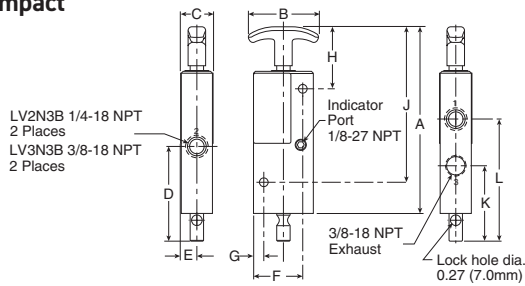

Compact LV Series, 3/8" Exhaust Port Dimensions

A	B	C	D	E	F
6.50 (165)	2.25 (57)	1.05 (27)	3.04 (77)	.51 (13)	1.58 (40)
G	H	J	K	L	
0.33 (8)	1.99 (51)	4.99 (127)	2.42 (62)	3.92 (100)	

Inches (mm)

Standard

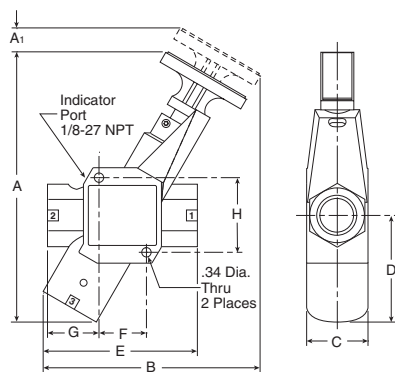

Compact LV Series, 3/4" Exhaust Port Dimensions

A	A ₁	B	C	D	E
8.32 (211)	0.64 (16)	6.60 (168)	2.00 (51)	3.06 (78)	4.24 (108)
F	G	H			
1.32 (111)	1.56 (40)	2.21 (56)			

Inches (mm)

Compact LV Series, 1-1/4" Exhaust Port Dimensions

A	A ₁	B	C	D	E
9.91 (252)	0.85 (22)	7.95 (202)	2.25 (57)	3.91 (99)	5.65 (144)
F	G	H			
1.74 (44)	1.89 (48)	2.74 (70)			

Inches (mm)

High Flow

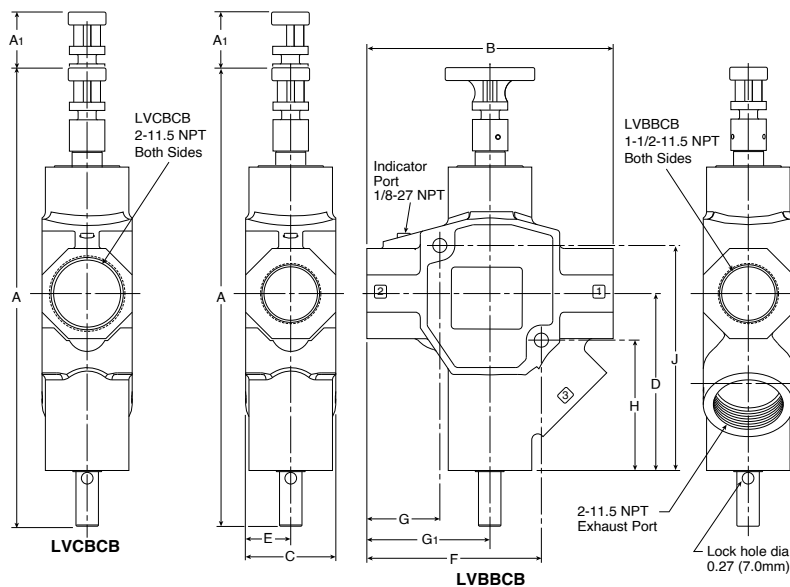

High Flow LV Series,
2" Exhaust Port Dimensions

A	A ₁	B
14.82 (376)	1.87 (47)	8.20 (208)
C	D	E
3.00 (76)	5.89 (150)	1.50 (38)
F	G	G ₁
5.81 (148)	2.43 (62)	4.10 (104)
H	J	
4.34 (110)	7.49 (190)	

Inches (mm)

LV Series, Exhaust Port - Compact, Standard, High Flow

Stainless Steel

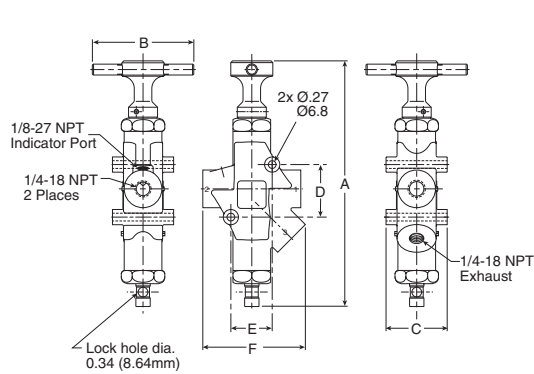

Stainless Steel LV Series, 1/4" Exhaust Port Dimensions

A	B	C	D	E	F
8.47	3.50	2.11	1.81	1.43	3.54
(215)	(89)	(54)	(46)	(36)	(90)

Inches (mm)

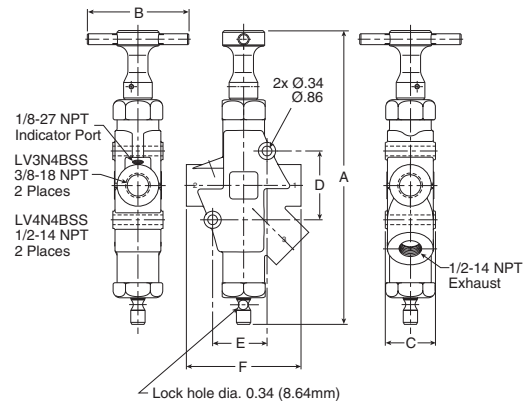

Stainless Steel LV Series, 1/2" Exhaust Port Dimensions

A	B	C	D	E	F
10.24	3.50	1.75	2.40	1.90	4.00
(260)	(89)	(45)	(61)	(48)	(102)

Inches (mm)

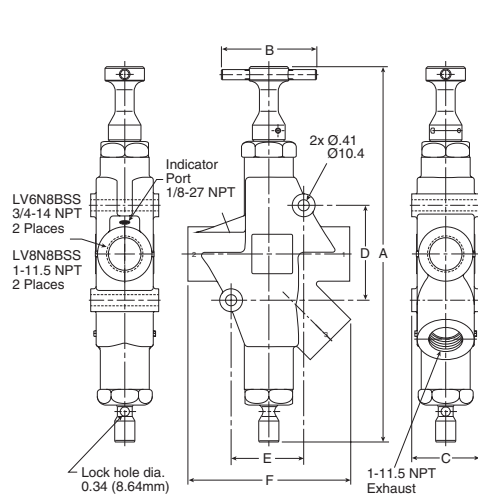

Stainless Steel LV Series, 1" Exhaust Port Dimensions

A	B	C	D	E	F
13.80	3.50	2.50	3.49	2.67	5.99
(351)	(89)	(64)	(89)	(68)	(152)

Inches (mm)

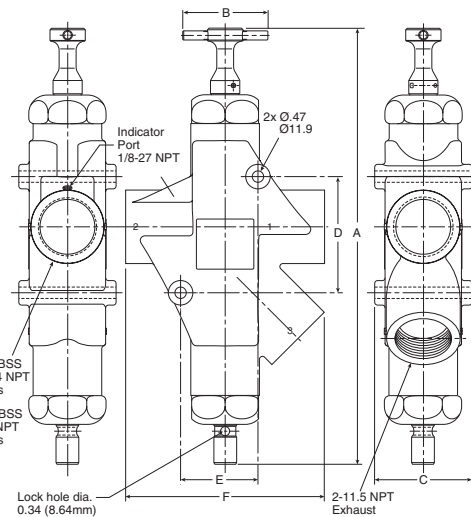

Stainless Steel LV Series, 2" Exhaust Port Dimensions

A	B	C	D	E	F
17.92	3.50	4.00	4.77	3.18	8.16
(455)	(89)	(102)	(121)	(81)	(207)

Inches (mm)

ES Series – Silencer

The silencer is designed to give superior performance in noise control with a minimum effect on air efficiency. "Trimline" design allows location in the tightest places without extra plumbing and fittings. Fits directly into the exhaust port of more than 90% of present commercial valves. Slotted body permits rapid discharge of air without undesirable back pressure. Unique nylon screen element resists dirt buildup or clogging.

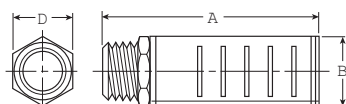

Operating information

Operating pressure: 17 bar max.
Operating temperature:* -18°C to +150°C

* Ambient temperatures below freezing require moisture-free air. Ambient temperatures below freezing and above 180° require lubricants especially selected for suitability at these temperatures. Pneumatic valves should be used with filtered and lubricated air.

ES Series – Silencer

Pipe thread	Flow scfm @ 100 psig inlet	Dimensions in mm			Part Numbers
		A	B	D	
1/8"	115	1.85	0.81	0.63	BSPT (R) ESB12MC
1/4"	129	1.85	0.81	0.63	ESB25MC
3/8"	219	3.31	1.26	1.00	ESB37MC
1/2"	549	3.31	1.26	1.00	ESB50MC
3/4"	893	4.56	2.01	1.62	ESB75MC
1"	1,013	4.56	2.01	1.62	ESB100MC
1-1/4"	1,486	5.69	2.88	—	ESB125MC
1-1/2"	1,580	5.69	2.88	—	ESB150MC

Stainless Steel Mufflers

Corrosion resistant mufflers for harsh environments



Pipe Thread	Construction	Threads	Dimensions in mm		Part Numbers
			Width	Length	
1/4	Stainless steel	Male, NPT	14.2	44.5	5500A2004
1/2	Stainless steel	Male, NPT	22.1	69.7	5500A4004
1	Stainless steel	Male, NPT	33.3	98.3	5500A6004
2	Nickel plated	Male, NPT	60.2	139.7	5500A9004*

* Nickel plated



Visual Pop-up Indicator - Part #988A30

- Visual verification of line exhaust to comply with regulations
- Can be used on all LV or EZ part numbers



Stainless - Part # 1155H30

- Can be used on SS LV series to provide visual verification of line exhaust



Pressure Switch - Part # PPS1-2C3-RHM (DIN 9.4mm)

- Signal verification of line exhaust
- Can be used on all LV, LVSS, or EZ part numbers
- Field adjustable set pressure point

Most popular.

NPT for indicator air port



Parker Hannifin Corporation
Electric Motion and Pneumatic Division - Europe

EZ Series

The EZ series meets all the same standards as the LV series with the added feature of a soft start when opened. There are still 2 detented positions for the handle (push close, pull to open), but when pulled open, an adjustable needle valve controls the rate of pressure build-up. This can protect equipment during start up after maintenance. The EZ is distinguishable from the LV series by the blue dot on the label.

Features

- Combines lockout and soft-start functions in a single unit
- Used in systems for compliance with OSHA standard 29 CFR part 1910
- 3/8 Inch to 1-1/4 inch pipe sizes
- Cv's from 3.7 to 13.7
- Exhaust port threaded for installation of silencer or line for remote exhausting
- Inline or surface mountable
- Yellow cast aluminum body with red handle. Blue dot on body indicates EZ Series valve
- Fluorocarbon slipper seals for easy shifting, even after long periods of inactivity

Operating information

Operating pressure:	Standard	15 to 300 PSIG
Operating temperature:		40°F to 175°F
Operating media:		Clean, dry, compressed air (5 micron)

Material specifications

Description	
Body:	Cast aluminum alloy
Handle:	Plastic
Spool:	Aluminum
Seals:	Carboxylated nitrile
Detent spring:	Stainless steel
Grease:	Magnalube G [†]

[†] Trademark Magnalube

EZ Series

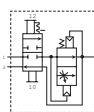

Port In/Out	Port Exhaust	dm ³ /s In/Out	dm ³ /s Exhaust	Wt (kg)	Part Number BSPP *
3/8	3/4	65	86	0,95	EZ03BB6
1/2	3/4	77	90	0,95	EZ04BB6
3/4	3/4	87	103	0,95	EZ06BB6
3/4	1-1/4	130	118	1,45	EZ06BBA
1	1-1/4	148	130	1,45	EZ08BBA
1-1/4	1-1/4	175	213991	1,45	EZ0ABBA

NOTE: Exhaust flow rates calculated using inlet pressure 100 psig (6.7 bar), pressure drop 5 psi (0.34 bar), air temp 68°F (20°C), and 36% relative humidity.

* Indicator air port is NPT thread

EZ Series, Exhaust Port - Standard Flow

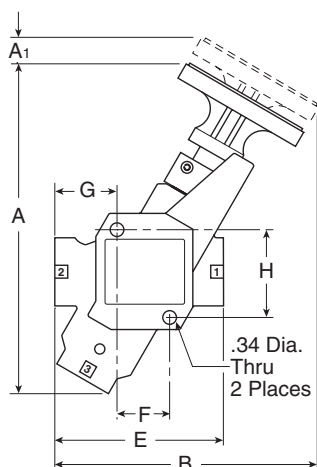

EZ 3/4" Exhaust Port Dimensions

A	A1	B	C	D
8.32 (211)	0.64 (16)	6.60 (168)	2.00 (51)	3.06 (78)

E	F	G	H
4.24 (108)	1.32 (111)	1.56 (40)	2.21 (56)

Inches (mm)

EZ 1-1/4" Exhaust Port Dimensions

A	A1	B	C	D
9.91 (252)	0.85 (22)	7.95 (202)	2.25 (57)	3.91 (99)

E	F	G	H
5.65 (144)	1.74 (44)	1.89 (48)	2.74 (70)

Inches (mm)

Most popular.



Parker Hannifin Corporation
Electric Motion and Pneumatic Division Europe
Robert-Bosch-Strasse 22
77656 Offenburg
Germany
www.parker.com

PNDE3003TCUK 03/2024

Your Local Authorized Parker Distributor

© 2024 Parker Hannifin Corporation

