



AIR PREPARATION SYSTEM HI-FLOW FRS

1/4 to 2 Body Ports



Parker Hi-Flow Filters and Regulators

Particulate Filters General Information 3
 F602 - 3/4, 14-5
 F602 - 1-1/2.....6-7

Regulators General Information.....8-9

Regulators

R119 - 1/4, 3/8, 1/210-11
 R119 - 3/4, 1 12-13

Pilot Operated Regulators

R119 - 1/4, 3/8, 1/214-15
 R119 - 3/4, 1, 1-1/216-17
 R119 - 2"18-19



WARNING – USER RESPONSIBILITY

FAILURE OR IMPROPER SELECTION OR IMPROPER USE OF THE PRODUCTS DESCRIBED HEREIN OR RELATED ITEMS CAN CAUSE DEATH, PERSONAL INJURY AND PROPERTY DAMAGE.

- This document and other information from Parker-Hannifin Corporation, its subsidiaries and authorized distributors provide product or system options for further investigation by users having technical expertise.
- The user, through its own analysis and testing, is solely responsible for making the final selection of the system and components and assuring that all performance, endurance, maintenance, safety and warning requirements of the application are met. The user must analyze all aspects of the application, follow applicable industry standards, and follow the information concerning the product in the current product catalog and in any other materials provided from Parker or its subsidiaries or authorized distributors.
- To the extent that Parker or its subsidiaries or authorized distributors provide component or system options based upon data or specifications provided by the user, the user is responsible for determining that such data and specifications are suitable and sufficient for all applications and reasonably foreseeable uses of the components or systems.

SALE CONDITIONS

The items described in this document are available for sale by Parker Hannifin Corporation, its subsidiaries or its authorized distributors. Any sale contract entered into by Parker will be governed by the provisions stated in Parker's standard terms and conditions of sale (copy available upon request).



Particulate and Coalescing Filters

Warning

The plastic material used to manufacture the plastic bowls, and the sight gauge on metal bowls, may be attacked by certain chemicals. Do not use this filter on systems with air supplied by a compressor lubricated with synthetic oils or oils containing phosphate esters or chlorinated hydrocarbons. These oils can carry over into the air lines and chemically attack and possibly rupture the bowl or sight gauge. Also, do not expose the bowl or sight gauge to materials such as carbon tetrachloride, trichlorethylene, acetone, paint thinner, cleaning fluids, or other harmful materials, for they too will cause the plastic to craze and/or rupture. For use in environments where these, or any, chemicals may be present, consult the factory for approval.

Coalescing Filters

These high-efficiency filters operate on a somewhat different principle than particulate air filters. The key difference is in the element, where a fiber network is narrowly spaced to trap smaller contaminants. The special fibers hold any liquid particle which contacts them.

Pre-filtered (A particulate filter must be used prior to a coalescing filter) air enters the cylindrical element at the center. As it flows through the element, particles are captured by three different mechanisms: direct interception as particles impinge on the fibers; inertial impaction as particles are thrown against fibers by the turbulent air stream; and diffusion as smaller particles vibrate with Brownian movement to collide with fibers and other particles. As a result, coalescing elements can capture particles smaller than the nominal size of the flow passages through the element.

Collected liquid migrates to the crossing points of the fibers where larger drops form or coalesce. Pressure differential through the element then forces these drops to the downstream surface of the element where they gravitate downward to the sump.

The filtered air then exits through the outlet port.

It is very important that the air be pre-filtered, as larger contaminants tend to block the passages between fibers, reducing the efficiency of the coalescing element.

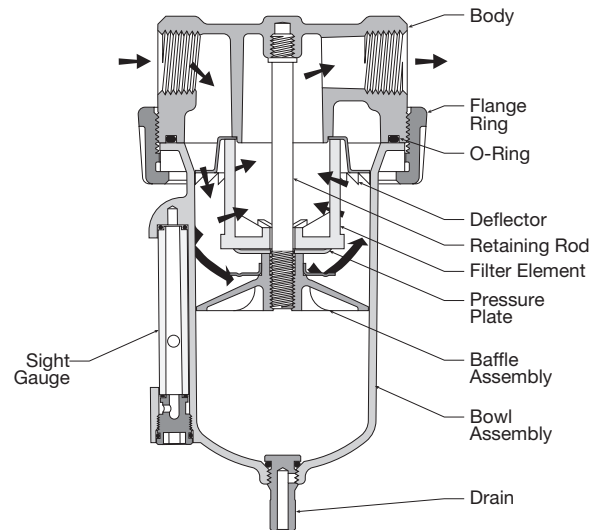

Particulate Filters

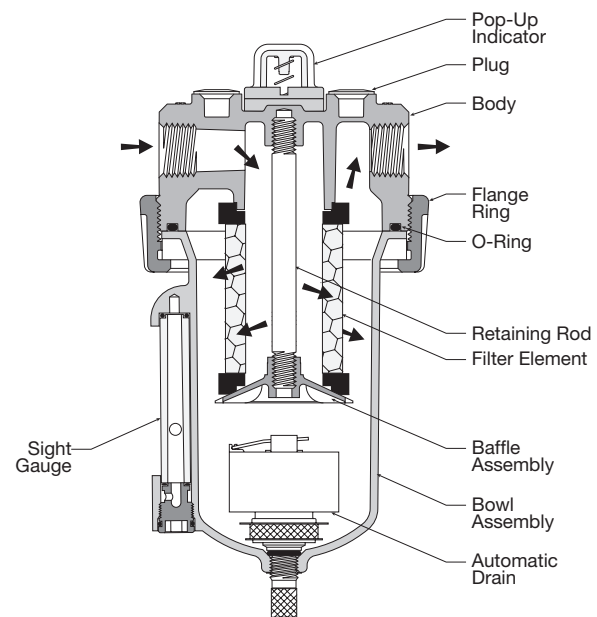

Coalescing Filters

Hi-Flow Particulate Filters - F602

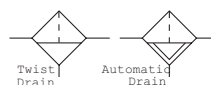
Symbols

- Excellent water removal efficiency
- For heavy duty applications with minimum pressure drop requirement
- Unique deflector plate that creates swirling of the air stream ensuring maximum water and dirt separation
- Large filter element surface guarantees low pressure drop and increased element life
- 40 micron filter element standard, 5 micron available
- Metal bowl with sight gauge standard
- Twist drain as standard, optional auto drain
- 3/4" & 1" port (BSPP, NPT)

Order Code for Ordering:

BSPP Port size	Description	Flow* dm ³ /s (scfm)	Max. bar (psig)	Height mm (inches)	Width mm (inches)	Depth mm (inches)	Weight kg (lb)	Part number
3/4"	16 oz. metal bowl / manual drain	127,4 (270)	17,2 (250)	221 (8.72)	124 (4.9)	124 (4.9)	2,86 (6.3)	F602G06WJ
3/4"	16 oz. metal bowl / auto drain	127,4 (270)	11,9 (175)	221 (8.72)	124 (4.9)	124 (4.9)	2,86 (6.3)	F602G06WJR
3/4"	32 oz. metal bowl / manual drain	127,4 (270)	20,7 (300)	303 (11.94)	124 (4.9)	124 (4.9)	2,86 (6.3)	F602G06EJ
3/4"	32 oz. metal bowl / auto drain	127,4 (270)	11,9 (175)	303 (11.94)	124 (4.9)	124 (4.9)	2,86 (6.3)	F602G06EJR
1"	16 oz. metal bowl / manual drain	141,5 (300)	17,2 (250)	221 (8.72)	124 (4.9)	124 (4.9)	3,18 (7.0)	F602G08WJ
1"	16 oz. metal bowl / auto drain	141,5 (300)	11,9 (175)	221 (8.72)	124 (4.9)	124 (4.9)	3,18 (7.0)	F602G08WJR
1"	32 oz. metal bowl / manual drain	141,5 (300)	20,7 (300)	303 (11.94)	124 (4.9)	124 (4.9)	3,18 (7.0)	F602G08EJ
1"	32 oz. metal bowl / auto drain	141,5 (300)	11,9 (175)	303 (11.94)	124 (4.9)	124 (4.9)	3,18 (7.0)	F602G08EJR

* dm³/s (scfm) = Standard cubic feet per minute at 6.2 bar (90 psig) inlet and 0,34 bar (5 psig) pressure drop.

Options:

F602						/**
Port Threads						Engineering Level
NPT	-					/** Will be entered at factory
G BSPP	G					
		Port Size				Drains and Options
		3/4 inch	06			Blank Manual twist drain
		1 inch	08			Q External heavy duty auto drain
						R Internal auto drain
						U Semi-auto drain
		Bowl				Element
		32 oz. Large capacity metal without sight gauge	E			G 5 Micron
		16 oz. Metal with sight gauge	W			J 40 Micron

Standard order code shown in bold.

PNDE3002TCUK

Parker Hi-Flow Filters and Regulators

F602 - 3/4", 1"

Specifications

Flow capacity*	3/4" 1"	127,4 dm ³ /s ANR (270 scfm) 141,5 dm ³ /s ANR (300 scfm)
Operating temperature		
Aluminum (E)		4,4°C to 65,6°C (40°F to 150°F)
Zinc with gauge (W)		4,4°C to 65,6°C (40°F to 150°F)
With internal auto drain [R]		4,4°C to 52°C (40°F to 125°F)
With external auto drain [Q]		4,4°C to 65,6°C (40°F to 150°F)
Max supply pressure		
Aluminum (E)		0 to 20,7 bar (0 to 300 psig)
Zinc with gauge (W)		0 to 17,2 bar (0 to 250 psig)
With internal auto drain [R]		1,4 to 11,9 bar (20 to 175 psig)
With external auto drain [Q]		0 to 17,2 bar (0 to 250 psig)
Bowl capacity	Zinc with gauge (W) Aluminum (E)	16 oz 32 oz
Port size		3/4, 1
Weight	16 oz 32 oz	2,86 kg (6.3 lb) 3,18 kg (7.0 lb)

* dm³/s (scfm) = Standard cubic feet per minute at 6,2 bar (90 psig) inlet, 0,34 bar (5 psig) pressure drop.
() Bowl type, [] Drain type

Dimensions mm (inches)

F602G06W, F602G08W (Hi-Flow)

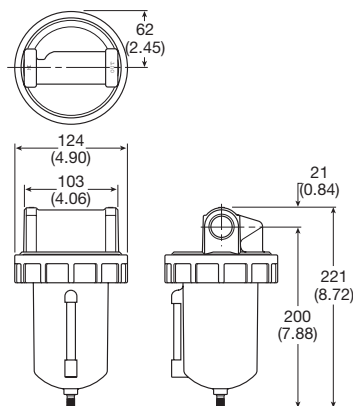

F602G06E, F602G08E (Hi-Flow)

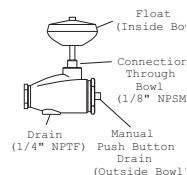
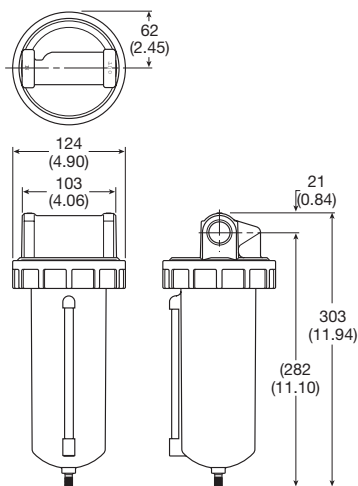

"Q" Option External Heavy Duty Auto Drain SA602D / SA603D

For heavy duty applications where the filter is being used to remove large volumes of liquid and/or particulate matter from the airstream, the external automatic drain ("Q" option) should be used.

Flow Charts

F602 3/4" Particulate Filter

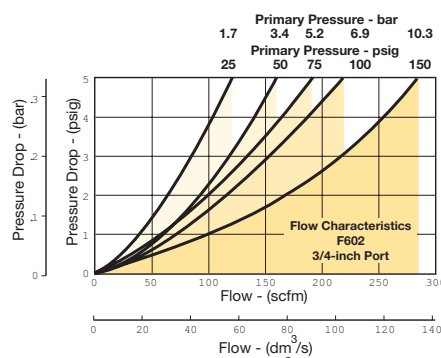

F602 1" Particulate Filter

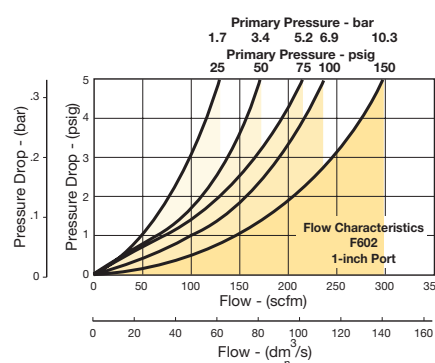

Material Specifications

Body	Zinc
Bowl (E) 32 oz. without sight gauge	Aluminum
Bowl (W) 16 oz. with sight gauge	Zinc
Manual twist drain & overnight	Brass
Drain housing "R"	Acetal
Drain housing "Q"	Brnze
Element	Polypropylene
Seals	Nitrile
Sight gauge	Nylon

Repair and Service Kits

Aluminum bowl (E) 32 oz.	BK603B
Zinc bowl with sight gauge (W) 16 oz.	BK605WB
External auto drain (E) 32 oz.	SA603D
External auto drain (W) 16 oz.	SA602D
Internal auto drain (All)	SA602MD
Manual drain (All)	SA600Y7-1
Semi-auto "overnight" drain (drains automatically under zero pressure)	SA602A7
40 micron element (All)	EK602B
5 micron element (All)	EK602VB
Mounting bracket, 3/4" Unit (pair or 2 kits pipe mounted brackets needed)	SA200AW57
Mounting bracket, 1" Unit (pair or 2 kits pipe mounted brackets needed)	SA200CW57
Deflector, baffle assembly, & retaining rod (E,W)	RK602B
External auto drain (All)	RK602D
Internal auto drain (All)	RK602MD
Sight glass repair kit (W)	RKB605WB



PNDE3002TCUK

Parker Hi-Flow Filters and Regulators

F602 - 1-1/2"

Hi-Flow Particulate Filters - F602



Symbols

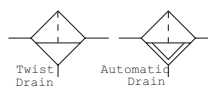

- Excellent water removal efficiency
- For heavy duty applications with minimum pressure drop requirement
- Unique deflector plate that creates swirling of the air stream ensuring maximum water and dirt separation
- Large filter element surface guarantees low pressure drop and increased element life
- 40 micron filter element standard, 5 micron available
- Metal bowl with sight gauge standard
- Twist drain as standard, optional auto drain
- Large bowl capacity
- Optional high capacity bowl(s) available
- 1-1/2" port (BSPP, NPT)

Order Code for Ordering:

Port size	Description	Flow* dm ³ /s (scfm)	Max. bar (psig)	Height mm (inches)	Width mm (inches)	Depth mm (inches)	Weight kg (lb)	Part number
1-1/2"	16 oz. metal bowl / manual drain	212,4 (450)	17,2 (250)	240 (9.46)	132 (5.19)	124 (4.9)	3,18 (7.0)	F602G12WJ
1-1/2"	16 oz. metal bowl / auto drain	212,4 (450)	11,9 (175)	240 (9.46)	132 (5.19)	124 (4.9)	3,18 (7.0)	F602G12WJR
1-1/2"	32 oz. metal bowl / manual drain	212,4 (450)	20,7 (300)	322 (12.69)	132 (5.19)	124 (4.9)	3,49 (7.7)	F602G12EJ
1-1/2"	32 oz. metal bowl / auto drain	212,4 (450)	11,9 (175)	322 (12.69)	132 (5.19)	124 (4.9)	3,49 (7.7)	F602G12EJR

* dm³/s (scfm) = Standard cubic feet per minute at 6.2 bar (90 psig) inlet and 0,34 bar (5 psig) pressure drop.

Options:

F602		12				/**
Port Threads						Engineering Level
NPT	-					/** Will be entered at factory
G BSPP	G					
	Port Size					Drains and Options
	1-1/2 inch	12				Blank Manual twist drain
						Q External heavy duty auto drain
						R Internal auto drain
						U Semi-auto drain
	Bowl					Element
	32 oz. Large capacity metal without sight gauge	E				G 5 Micron
	16 oz. Metal with sight gauge	W				J 40 Micron

Standard order code shown in bold.



Parker Hannifin Corporation
Electric Motion and Pneumatic Division - Europe

PNDE3002TCUK

Parker Hi-Flow Filters and Regulators

F602 - 1-1/2"

Specifications

Flow capacity†	1-1/2"	212,4 dm ³ /s ANR (450 scfm)
Operating temperature		
Aluminum (E)		4,4°C to 65,6°C (40°F to 150°F)
Zinc with gauge (W)		4,4°C to 65,6°C (40°F to 150°F)
With internal auto drain [R]		4,4°C to 52°C (40°F to 125°F)
With external auto drain [Q]		4,4°C to 65,6°C (40°F to 150°F)
Max supply pressure		
Aluminum (E)		0 to 20,7 bar (0 to 300 psig)
Zinc with gauge (W)		0 to 17,2 bar (0 to 250 psig)
With internal auto drain [R]		1,4 to 11,9 bar (20 to 175 psig)
With external auto drain [Q]		0 to 17,2 bar (0 to 250 psig)
Bowl capacity	Zinc with gauge (W)	16 oz
	Aluminum (E)	32 oz
Port size		1-1/2
Weight	16 oz	3,18 kg (7.0 lb)
	32 oz	3,49 kg (7.7 lb)

† dm³/s (scfm) = Standard cubic feet per minute at 6,2 bar (90 psig) inlet, 0,34 bar (5 psig) pressure drop.
() Bowl type, [] Drain type

Dimensions mm (inches)

F602G12W (Hi-Flow)

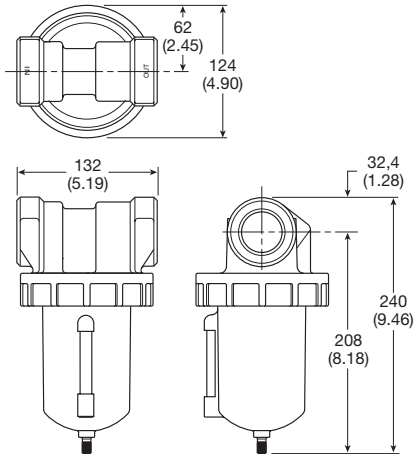

F602G12E (Hi-Flow)

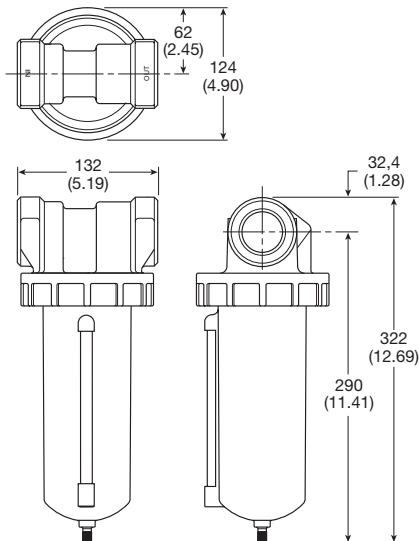

Flow Charts

F602 1-1/2" Particulate Filter

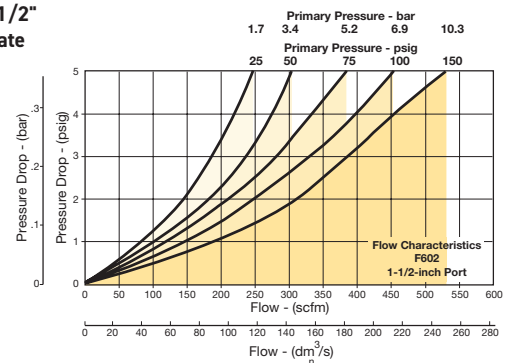

Material Specifications

Body	Zinc
Bowl (E) 32 oz. without sight gauge	Aluminum
Bowl (W) 16 oz. with sight gauge	Zinc
Manual twist drain & overnight	Brass
Drain housing "R"	Acetal
Drain housing "Q"	Bronze
Element	Polypropylene
Seals	Nitrile
Sight gauge	Nylon

Repair and Service Kits

Aluminum bowl (E) 32 oz.	BK603B
Zinc bowl with sight gauge (W) 16 oz.	BK605WB
External auto drain (E) 32 oz.	SA603D
External auto drain (W) 16 oz.	SA602D
Internal auto drain (All)	SA602MD
Manual drain (All)	SA600Y7-1
Semi-auto "overnight" drain (drains automatically under zero pressure)	SA602A7
40 micron element (All)	EK602B
5 micron element (All)	EK602VB
Deflector, baffle assembly, & retaining rod (E,W)	RK602B
External auto drain (All)	RK602D
Internal auto drain (All)	RK602MD
Sight glass repair kit (W)	RKB605WB

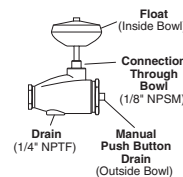

"Q" Option External Heavy Duty Auto Drain SA602D / SA603D

For heavy duty applications where the filter is being used to remove large volumes of liquid and/or particulate matter from the airstream, the external automatic drain ("Q" option) should be used.

Regulators

Regulation

An air regulator is a specialized control valve. It reduces upstream supply pressure level to a specified constant downstream pressure.

Pneumatic equipment that is operated at higher-than-recommended pressure wastes the energy to generate that pressure. It creates a potential safety hazard, and probably will wear out prematurely. Operating below specified pressure can cause the machine to fail to meet design performance specifications. Therefore, precise air pressure control is essential to efficient operation of air-powered equipment.

How to Select the Proper Regulator

While regulator bodies are generally constructed of die-cast metal, other external parts may be either metal or plastic. Remember that all-metal construction is best for tough applications, where abuse is likely to occur, but plastic construction is generally lower in cost. For normal industrial applications, either construction is suitable.

Inlet pressure rating and downstream controlled range, as well as flow capacity, must be determined before selecting a regulator. Port size should match piping size.

Required response time, relieving capability, and type of adjustment are other considerations. Highly sensitive, lightweight diaphragm sensors vs. the slower, but often more durable, piston sensors. Self-relieving vs. non-relieving regulators. T-Handles or knobs as the adjustment mechanism, or air pilot operated regulator which offer remote adjustment. Other choices to be made include gauge, panel mount and other special options.

Regulator Construction

Regulators are generally constructed using a die-cast metal body. Other external parts, such as the spring cage and bottom plug, may be either metal or plastic. All-metal construction offers more durability in tough applications where abuse is likely to occur, while the plastic construction offers lower cost. For normal industrial applications (temperature range of 40° to 120° F and supply pressure to 300 PSIG), either construction will serve well.

Lightweight diaphragm sensors offer quick response and high sensitivity to air pressure changes. Piston sensors are somewhat slower but may be more durable. Where downstream pressure requirements change rapidly enough to cause regular chatter, slower response may be an advantage.

If the self-relieving feature is not needed for an application, simpler non-relieving regulators are available.

For regulators with an adjustment spring, a -T-Handle or knob provides the external link to the spring on various models.

Pilot-operated regulators substitute air pressure in the chamber above the sensor to provide the reference force. Remote adjustment through a separate pilot regulator thus becomes possible, or the pilot signal can be fed back from a downstream location for precise control.

The balanced inner valve design exposes both sides of the inner valve to essentially the same pressure. This eliminates much of the effect that changes in inlet pressure might have on inner valve position and orifice opening.

Regulator Operation

In a typical regulator, an inner valve sets the size of an orifice which connects inlet port to outlet port. The sensing element, often a diaphragm or piston mechanically linked to the inner valve, reacts to downstream pressure and a reference force to position the inner valve. The reference force can be a spring, or an air pilot chamber.

The valve is normally open. High pressure air enters and flows through the orifice toward the outlet. Downstream pressure is connected through an aspirator tube to the bottom of the diaphragm. As downstream pressure increases, the diaphragm is forced upward, compressing the adjustment spring. When the diaphragm moves, the inner valve spring pushes the inner valve disc upward to throttle the orifice. If downstream pressure exhausts, the mechanical sequence reverses and the inner valve disc opens the orifice until the set pressure is reached again.

The arrangement of separate diaphragm chamber and aspirator tube accomplishes two purposes. First, the diaphragm is moved out of the potentially abrasive air stream. Second, and more important, if the downstream system calls for high flow, this flow generates a low pressure venturi effect at the end of the aspirator tube and into the diaphragm chamber. The diaphragm therefore reacts more quickly to open the orifice via the inner valve, thereby improving response time to high flow demands.

Some circuits may be subject to downstream-generated high pressure (from high temperatures or heavy vertical loads on cylinders, for example). This high pressure is reduced by a self-relieving feature built into the regulator. The inner valve stem normally blocks a relieving orifice in the center of the diaphragm. If excessive pressure lifts the diaphragm off the stem, air bleeds through the orifice and out the spring cage vent until the system returns to the set pressure.

Regulators

Regulator Comparison Chart

Examples →	High Precision Regulators			Precision Regulator	
	R210	R220	R230	R216	
Repeatability / Sensitivity	Regulator's ability to return to a set pressure after inducing flow	0.005 PSIG 1/8" Water Column	0.005 PSIG 1/8" Water Column	0.010 psig 1/4" Water Column	0.5 to 1.0 psig
Reduced Pressure Variation	This refers to the regulator's ability to maintain a consistent output pressure when faced with variables such as time, cycling, temperature, supply pressure, flow, etc.	Best	Best	Better	Good
Input Pressure	Unregulated air pressure going into the regulator	150 PSIG Max.	150 PSIG Max.	250 PSIG Max.	Varies
Effect of Supply Pressure Variation on Regulated Pressure	Reduced / set pressure variation when input pressure changes by 100 PSIG	0.020 PSIG	0.020 PSIG	0.100 PSIG	4 PSIG
Reduced Pressure Range	Reduced pressure ranges available	2-40 PSIG 2-120 PSIG	2-120 PSIG	0-2 PSIG 0-30 PSIG 0-60 PSIG 0-150 PSIG	Varies
Flow Capacity	Regulator's flow capacity	14 SCFM	14 SCFM	80 SCFM	Varies
Exhaust (Relief) Capacity	Regulator's exhaust/relief flow rating when backpressure is introduced from downstream	3 SCFM	11 SCFM	4 SCFM	Low
Overpressure to Relieve <i>*Key in cylinder applications</i>	Regulator's sensitivity to relieve excess downstream pressure over the set pressure	Best (0.005 PSIG)	Best (0.005 PSIG)	Better (0.010 PSIG)	Good (1 PSIG)
Constant Bleed	Does the regulator constantly bleed air to the atmosphere to maintain accuracy?	Yes	Yes	Yes	Varies
Size Constraints	Overall size of regulator	4.5" H x 2.06" W	4.5" H x 2.06" W	5.5" H x 3" W	Varies
Mounting Constraints	Mounting options	Panel, Pipe, or Bracket	Panel, Pipe, or Bracket	Panel, Pipe, or Bracket	Panel, Pipe, Bracket, or Modular
Port Size	Inlet / Outlet port size	1/4"	1/4"	1/4" or 3/8"	Varies

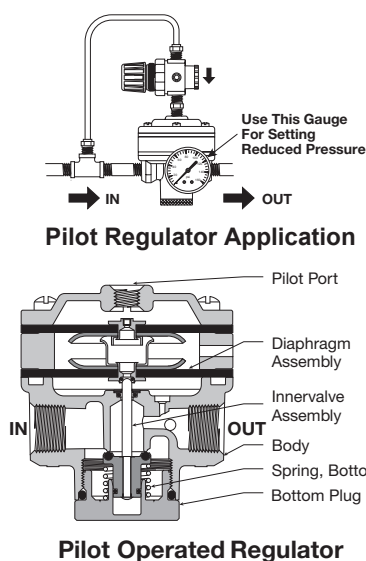
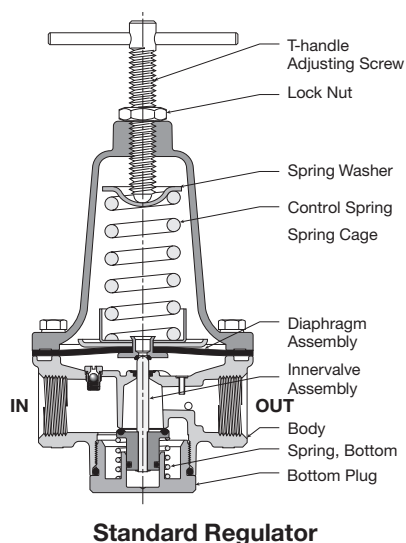

PNDE3002TCUK

Parker Hi-Flow Filters and Regulators

R119 - 1/4", 3/8", 1/2"

Standard Regulators - R119



Symbols

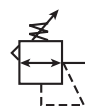

- High flow performance featuring rugged design for the most demanding applications
- Ideal for those installations calling for constant pressure with wide variation in flow
- Diaphragm operated design with balanced poppet design for quick and accurate regulation
- Secondary aspiration plus balanced poppet provides quick response and accurate pressure regulation
- Heavy duty tee handle adjustment
- Reverse flow version available
- Panel mount version available
- 1/4", 3/8", 1/2" ports (BSPP, NPT)

Order Code for Ordering:

Port size	Description (0-125 psig reduced pressure)	Flow [†] dm ³ /s (scfm)	Max. bar (psig)	Height mm (inches)	Width mm (inches)	Depth mm (inches)	Weight kg (lb)	Part number
1/4"	Without gauge, relieving	47,2 (100)	20,7 (300)	169 (6.67)	76 (3.0)	76 (3.0)	0,82 (1.8)	R119G02C
1/4"	With gauge, relieving	47,2 (100)	20,7 (300)	169 (6.67)	76 (3.0)	76 (3.0)	0,82 (1.8)	R119G02CG
3/8"	Without gauge, relieving	51,9 (110)	20,7 (300)	169 (6.67)	76 (3.0)	76 (3.0)	0,82 (1.8)	R119G03C
3/8"	With gauge, relieving	51,9 (110)	20,7 (300)	169 (6.67)	76 (3.0)	76 (3.0)	0,82 (1.8)	R119G03CG
1/2"	Without gauge, relieving	70,8 (150)	20,7 (300)	175 (6.9)	90 (3.56)	90 (3.56)	1,45 (3.2)	R119G04C
1/2"	With gauge, relieving	70,8 (150)	20,7 (300)	175 (6.9)	90 (3.56)	90 (3.56)	1,45 (3.2)	R119G04CG

[†] dm³/s (scfm) = Standard cubic feet per minute at 7 bar (100 psig) inlet and 5,2 bar (75 psig) no flow secondary setting and 1,4 bar (20 psig) pressure drop.

Options:

R119					/**
Port Threads					Engineering Level
NPT					**
G BSPP					Will be entered at Factory
	Port Size				
	1/4 inch	02			
	3/8 inch	03			
	1/2 inch	04			
	Reduced Pressure Range				
	0 to 1,7 bar (0 to 25 psig)	A			
	0 to 4,1 bar (0 to 60 psig)	B			
	0 to 8,6 bar (0 to 125 psig)	C			
	0 to 17,2 bar (0 to 250 psig)	D			
	Options				
	Blank	None			
	G	Gauge			
	K [†]	Non-relieving			
	X64**	Fluorocarbon o-rings and diaphragm			
	X80*	Reverse flow			
	X7	Brass bottom plug			

Standard order code shown in bold.

* Reverse flow for use downstream of control valves.
 ** Brass bottom plug standard with X64 option.
 † Not available with 17,2 bar (250 psig) spring.

CAUTION:

REGULATOR PRESSURE ADJUSTMENT – The working range of knob adjustment is designed to permit outlet pressures within their full range. Pressure adjustment beyond this range is also possible because the knob is not a limiting device. This is a common characteristic of most industrial regulators, and limiting devices may be obtained only by special design. For best performance, regulated pressure should always be set by increasing the pressure up to the desired setting.

WARNING
Product rupture can cause serious injury. Do not connect regulator to bottled gas. Do not exceed Maximum primary pressure rating.



Parker Hannifin Corporation
Electric Motion and Pneumatic Division - Europe

PNDE3002TCUK

Parker Hi-Flow Filters and Regulators

R119 - 1/4", 3/8", 1/2"

Specifications

Flow capacity*	1/4"	47,2 dm ³ /s, ANR (100 scfm)
	3/8"	51,9 dm ³ /s, ANR (110 scfm)
	1/2"	70,8 dm ³ /s, ANR (150 scfm)
Operating temperature	4,4°C to 52°C (40°F to 125°F)	
Max supply pressure	0 to 20,7 bar (0 to 300 psig)	
Reduced pressure range	0,14 to 8,6 bar (2 to 125 psig)	
Port size	1/4, 3/8, 1/2	
Gauge ports (2)	1/4	
Weight	1/4"	0,82 kg (1.8 lb)
	3/8"	0,82 kg (1.8 lb)
	1/2"	1,45 kg (3.2 lb)

* dm³/s (scfm) = Standard cubic feet per minute at 6,2 bar (90 psig) inlet, 5,2 bar (75 psig) no flow secondary setting and 1,4 bar (20 psig) pressure drop.

Material Specifications

Adjusting screw, springs	Steel
Body, spring cage	Zinc
Bottom plug	Nylon
Innervalve	Brass
Seats	Buna N

Dimensions mm (inches)

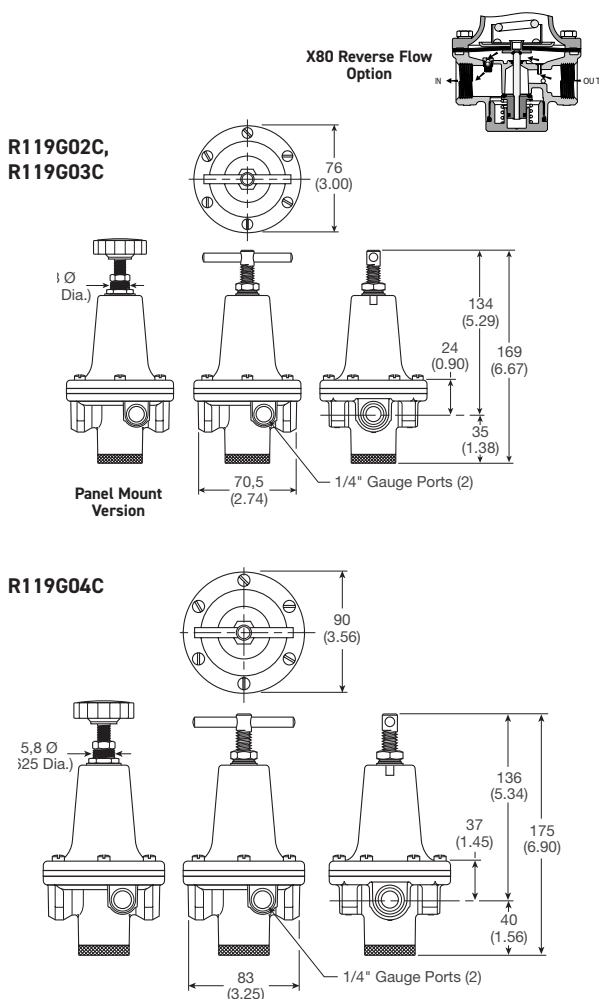

Flow Charts

R119 1/4" Regulator

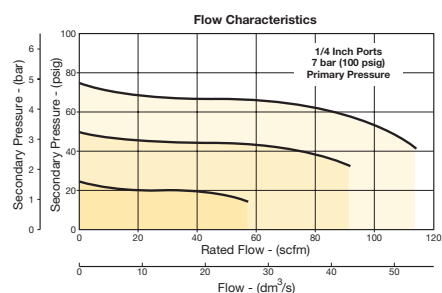

R119 3/8" Regulator

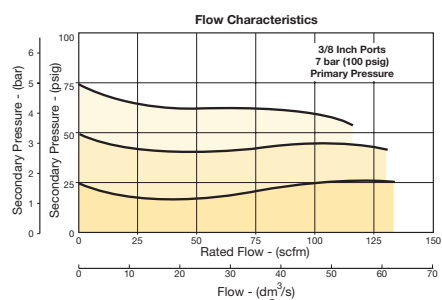

R119 1/2" Regulator

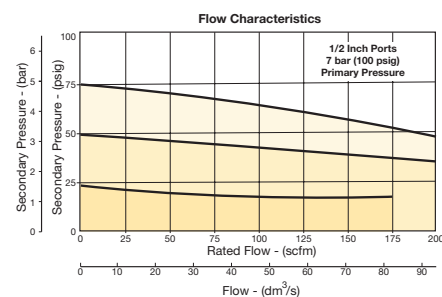

Repair and Service Kits

2" dial face 60 psig (0 to 4.1 bar), gauge	K4520N14060
2" dial face 160 psig (0 to 11.0 bar), gauge	K4520N14160
2" dial face 300 psig (0 to 20.7 bar), gauge	K4520N14300
1-3/4" digital round face 160 psig (0 to 11.0 bar), gauge	K4517N14160D
Mounting bracket, 1/4", 3/8"	SA15Y57
Mounting bracket, 1/2"	18A57
Panel mount conversion kit, 1/4", 3/8"	4202
Panel mount conversion kit, 1/2"	4204
Non-relieving diaphragm, valve assembly (1/4", 3/8"; all psig)	RK118Y
Relieving diaphragm, valve assembly (1/4", 3/8"; all psig)	RK119Y
Non-Relieving diaphragm, valve assembly (1/2"; 25, 60, 125 psig)	RK118A
Relieving diaphragm, valve assembly (1/2"; 25, 60, 125 psig)	RK119A
Relieving diaphragm, valve assembly (1/2"; 250 psig)	RK119A250
Spring cage & T-handle kit (1/4 & 3/8)	RKC119Y
Spring cage & insert only kit (1/2)	SAC18A3/BK

For fluorocarbon repair kits, add X64 to kit number suffix.



Hi-Flow Regulators - R119



Symbols

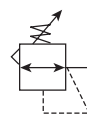

- High flow performance featuring rugged design for the most demanding applications
- Ideal for those installations calling for constant pressure with wide variation in flow
- Diaphragm operated design with balanced poppet design for quick and accurate regulation
- Secondary aspiration plus balanced poppet provides quick response and accurate pressure regulation
- Heavy duty tee handle adjustment
- Reverse flow version available
- 3/4", 1" ports (BSPP, NPT)

Order Code for Ordering:

Port size	Description (0-125 psig reduced pressure)	Flow [‡] dm ³ /s (scfm)	Max. bar (psig)	Height mm (inches)	Width mm (inches)	Depth mm (inches)	Weight kg (lb)	Part number
3/4"	Without gauge, relieving	141,6 (300)	20,7 (300)	255 (10.02)	119 (4.69)	119 (4.69)	2,81 (6.2)	R119G06C
3/4"	With gauge, relieving	141,6 (300)	20,7 (300)	255 (10.02)	119 (4.69)	119 (4.69)	2,81 (6.2)	R119G06CG
1"	Without gauge, relieving	188,8 (400)	20,7 (300)	255 (10.02)	119 (4.69)	119 (4.69)	2,81 (6.2)	R119G08C
1"	With gauge, relieving	188,8 (400)	20,7 (300)	255 (10.02)	119 (4.69)	119 (4.69)	2,81 (6.2)	R119G08CG

[‡] dm³/s (scfm) = Standard cubic feet per minute at 7 bar (100 psig) inlet and 5,2 bar (75 psig) no flow secondary setting and 1,4 bar (20 psig) pressure drop.

Options:

R119					/**
Port Threads					Engineering Level
NPT -					/** Will be entered at Factory
G BSPP G					
Port Size					Options
3/4 inch 06					Blank None
1 inch 08					G Gauge
Reduced Pressure Range					K Non-relieving
0 to 8,6 bar (0 to 125 psig) C					X64** Fluorocarbon o-rings and diaphragm
0 to 17,2 bar (0 to 250 psig) D					X80* Reverse flow
					X7 Brass Bottom Plug

Standard order code shown in bold.

* Reverse flow for use downstream of control valves.
** Brass bottom plug standard with X64 option.

CAUTION:

REGULATOR PRESSURE ADJUSTMENT – The working range of knob adjustment is designed to permit outlet pressures within their full range. Pressure adjustment beyond this range is also possible because the knob is not a limiting device. This is a common characteristic of most industrial regulators, and limiting devices may be obtained only by special design. For best performance, regulated pressure should always be set by increasing the pressure up to the desired setting.

<p>WARNING</p> <p>Product rupture can cause serious injury. Do not connect regulator to bottled gas. Do not exceed Maximum primary pressure rating.</p>



PNDE3002TCUK

Parker Hi-Flow Filters and Regulators

R119 - 3/4", 1"

Specifications

Flow capacity ‡	3/4"	141,6 dm ³ /s, ANR (300 scfm)
	1"	188,8 dm ³ /s, ANR (400 scfm)
Operating temperature	4,4°C to 52°C (40°F to 125°F)	
Max supply pressure	0 to 20,7 bar (0 to 300 psig)	
Reduced pressure range	0,14 to 8,6 bar (2 to 125 psig)	
Port size	3/4, 1, 1-1/2	
Gauge ports (2)	1/4	
Weight	3/4"	2,81 kg (6.2 lb)
	1"	2,81 kg (6.2 lb)

‡ dm³/s (scfm) = Standard cubic feet per minute at 6,2 bar (90 psig) inlet, 5,2 bar (75 psig) no flow secondary setting and 1,4 bar (20 psig) pressure drop.

Material Specifications

Adjusting screw, springs	Steel
Body, spring cage	Zinc
Bottom plug	Nylon
Innervalve	Brass
Seals	Buna N

Dimensions mm (inches)

R119G06C,
R119G08C

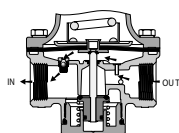
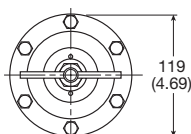

X80 Reverse Flow Option

1/4" NPT
Gauge Ports
(2)

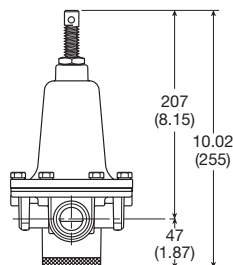
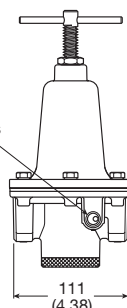

R119G12C

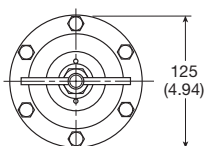

1/4" NPT
Gauge Ports
(2)

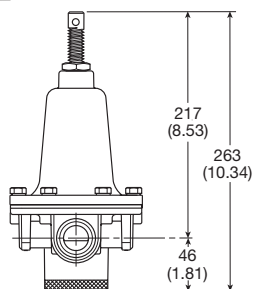
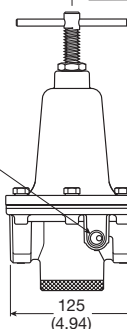

Flow Charts

R119 3/4" Regulator

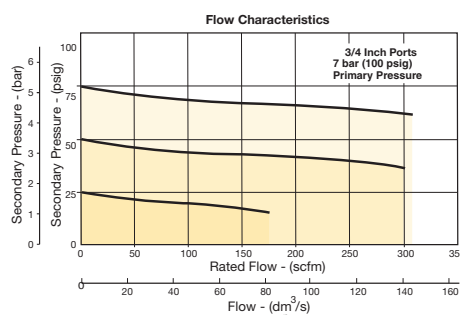

R119 1" Regulator

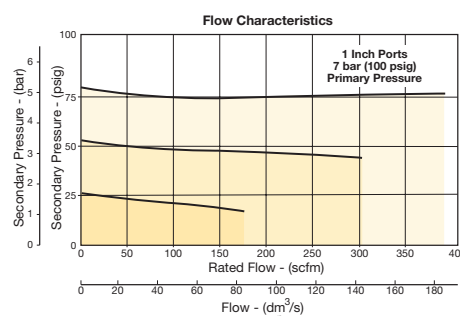

Repair and Service Kits

2" dial face 60 psig (0 to 4.1 bar), gauge **K4520N14060**

2" dial face 160 psig (0 to 11.0 bar), gauge **K4520N14160**

2" dial face 300 psig (0 to 20.7 bar), gauge **K4520N14300**

1-3/4" digital round face
160 psig (0 to 11.0 bar), gauge **K4517N14160D**

Mounting bracket kit **18B57**

Non-relieving diaphragm, valve assembly (3/4", 1") **RK118B**

Relieving diaphragm, valve assembly (3/4", 1") **RK119B**

For Fluorocarbon Repair Kits, add X64 to kit number suffix.



PNDE3002TCUK

Parker Hi-Flow Filters and Regulators

R119 - 1/4", 3/8", 1/2"

Pilot Operated Regulators - R119

Symbols

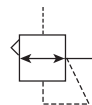

- Adapted for control by a remote or distant small pilot regulator. Ideal for maximum capacity requirements in applications where units are not readily accessible
- High flow performance featuring rugged design for the most demanding applications
- Ideal for those installations calling for constant pressure with wide variation in flow
- Diaphragm operated design with balanced poppet and constant bleed pilot for quick and accurate regulation.
- Secondary aspiration plus balanced poppet provides quick response and accurate pressure regulation
- Reverse flow available
- 1/4", 3/8", 1/2" ports (BSPP, NPT)

Order Code for Ordering:

Port size	Description (0-125 psig reduced pressure)	Flow* dm ³ /s (scfm)	Max. bar (psig)	Height mm (inches)	Width mm (inches)	Depth mm (inches)	Weight kg (lb)	Part number
1/4"	Without gauge, relieving	47,2 (100)	20,7 (300)	90 (3.55)	76 (3.0)	76 (3.0)	0.73 (1.6)	R119G02J
3/8"	Without gauge, relieving	51,9 (110)	20,7 (300)	90 (3.55)	76 (3.0)	76 (3.0)	0.73 (1.6)	R119G03J
1/2"	Without gauge, relieving	70,8 (150)	20,7 (300)	99 (3.9)	90 (3.56)	90 (3.56)	1.18 (2.6)	R119G04J

* dm³/s (scfm) = Standard cubic feet per minute at 7 bar (100 psig) inlet and 5,2 bar (75 psig) no flow secondary setting and 1,4 bar (20 psig) pressure drop.

Options:

R119			J		/**																
<table border="1"> <tr><th>Port</th></tr> <tr><td>NPT -</td></tr> <tr><td>BSPP G</td></tr> </table>	Port	NPT -	BSPP G	<table border="1"> <tr><th>Port Size</th></tr> <tr><td>1/4 inch 02</td></tr> <tr><td>3/8 inch 03</td></tr> <tr><td>1/2 inch 04</td></tr> </table>	Port Size	1/4 inch 02	3/8 inch 03	1/2 inch 04	<table border="1"> <tr><th>Reduced Pressure Range</th></tr> <tr><td>Air pilot operated J</td></tr> </table>	Reduced Pressure Range	Air pilot operated J	<table border="1"> <tr><th>Engineering Level</th></tr> <tr><td>/** Will be entered at Factory</td></tr> </table>	Engineering Level	/** Will be entered at Factory	<table border="1"> <tr><th>Options</th></tr> <tr><td>Blank None</td></tr> <tr><td>K Non-relieving</td></tr> <tr><td>X64* Fluorocarbon o-rings and diaphragm</td></tr> <tr><td>X71 Non-bleed (for use with electronic controllers)</td></tr> <tr><td>X7 Brass bottom plug</td></tr> </table>	Options	Blank None	K Non-relieving	X64* Fluorocarbon o-rings and diaphragm	X71 Non-bleed (for use with electronic controllers)	X7 Brass bottom plug
Port																					
NPT -																					
BSPP G																					
Port Size																					
1/4 inch 02																					
3/8 inch 03																					
1/2 inch 04																					
Reduced Pressure Range																					
Air pilot operated J																					
Engineering Level																					
/** Will be entered at Factory																					
Options																					
Blank None																					
K Non-relieving																					
X64* Fluorocarbon o-rings and diaphragm																					
X71 Non-bleed (for use with electronic controllers)																					
X7 Brass bottom plug																					
Standard order code shown in bold.					* Brass bottom plug standard with X64 option.																

CAUTION:

REGULATOR PRESSURE ADJUSTMENT – The working range of knob adjustment is designed to permit outlet pressures within their full range. Pressure adjustment beyond this range is also possible because the knob is not a limiting device. This is a common characteristic of most industrial regulators, and limiting devices may be obtained only by special design. For best performance, regulated pressure should always be set by increasing the pressure up to the desired setting.

WARNING
Product rupture can cause serious injury. Do not connect regulator to bottled gas. Do not exceed Maximum primary pressure rating.



PNDE3002TCUK

Parker Hi-Flow Filters and Regulators

R119 - 1/4", 3/8", 1/2"

Specifications

Flow capacity†	1/4"	141,6 dm ³ /s, ANR (300 scfm)
	3/8"	188.8 dm ³ /s, ANR (400 scfm)
	1/2"	236 dm ³ /s, ANR (500 scfm)
Operating temperature	4,4°C to 52°C (40°F to 125°F)	
Pilot pressure	1/4", 3/8" thread - 1/8" 1/2" thread - 1/4"	
Reduced pressure range	Adjustable to within 0,34 to 0,48 bar (5 to 7 psig) of supply pressure	
Max supply pressure	0 to 20,7 bar (0 to 300 psig)	
Air consumption	Constant bleed from air pilot chamber: approx. 10 scfh (0.17 scfm)	
Port size	1/4, 3/8, 1/2	
Gauge ports (2)	1/4	
Weight	1/4"	0,73 kg (1.6 lb)
	3/8"	0,73 kg (1.6 lb)
	1/2"	1,18 kg (2.6 lb)

† dm³/s (scfm) = Standard cubic feet per minute at 6,2 bar (90 psig) inlet, 5.2 bar (75 psig) no flow secondary setting and 1,4 bar (20 psig) pressure drop.

Material Specifications

Body, ring, top plate	Zinc
Bottom plug	Nylon
Innervalve	Brass
Seals	Buna N

Dimensions mm (inches)

R119G02J,
R119G03J

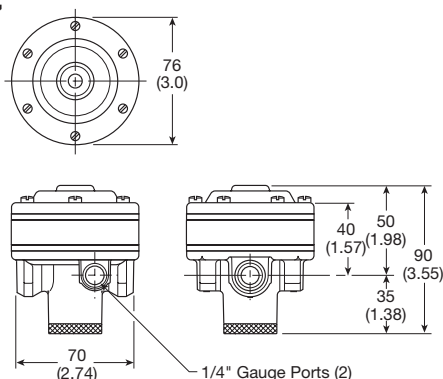

R119G04J

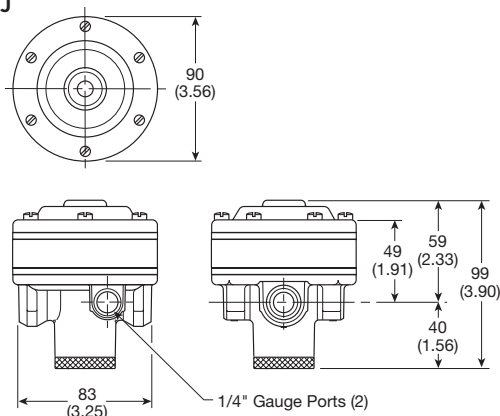

Flow Charts

R119 1/4" Regulator

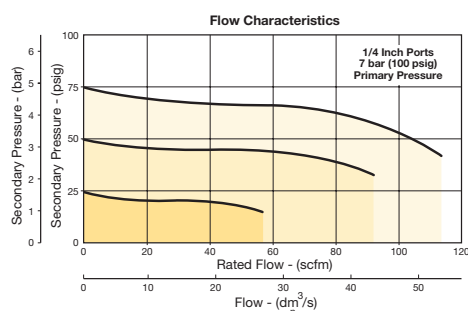

R119 3/8" Regulator

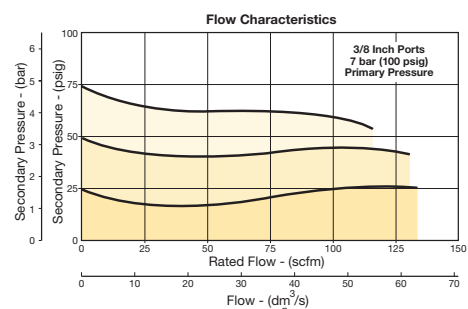

R119 1/2" Regulator

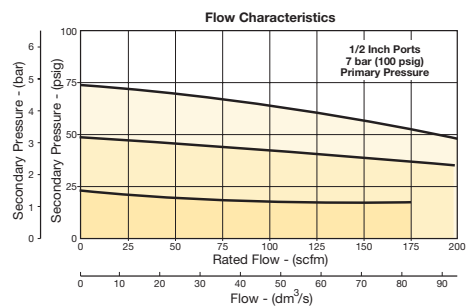

Repair and Service Kits

2" dial face 60 psig (0 to 4.1 bar), gauge	K4520N14060
2" dial face 160 psig (0 to 11.0 bar), gauge	K4520N14160
2" dial face 300 psig (0 to 20.7 bar), gauge	K4520N14300
1-3/4" digital round face 160 psig (0 to 11.0 bar), gauge	K4517N14160D
Non-relieving diaphragm, valve assembly (1/2")	RK118X20A
Non-relieving diaphragm, valve assembly (1/4", 3/8")	RK118X20Y
Relieving diaphragm, valve assembly (1/2")	RK119X20A
Relieving diaphragm, valve assembly (1/4", 3/8")	RK119X20Y

For fluorocarbon repair kits, add X64 to kit number suffix.
For non-bleed pilot repair kits, add X71 to kit number suffix.

Pilot Operated Regulators - R119

Symbols

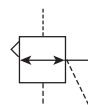

- Adapted for control by a remote or distant small pilot regulator. Ideal for maximum capacity requirements in applications where units are not readily accessible
- High flow performance featuring rugged design for the most demanding applications
- Ideal for those installations calling for constant pressure with wide variation in flow
- Diaphragm operated design with balanced poppet and constant bleed pilot for quick and accurate regulation
- Secondary aspiration plus balanced poppet provides quick response and accurate pressure regulation
- Reverse flow version available
- 3/4", 1", 1-1/2" ports (BSPP, NPT)

Order Code for Ordering:

Port size	Description (0-125 psig reduced pressure)	Flow [†] dm ³ /s (scfm)	Max. bar (psig)	Height mm (inches)	Width mm (inches)	Depth mm (inches)	Weight kg (lb)	Part number
3/4"	Without gauge, relieving,	114,6 (300)	20,7 (300)	122 (4.81)	120 (4.72)	120 (4.72)	2,36 (5.2)	R119G06J
1"	Without gauge, relieving,	114,6 (300)	20,7 (300)	122 (4.81)	120 (4.72)	120 (4.72)	2,36 (5.2)	R119G08J
1-1/2"	Without gauge, relieving,	236 (500)	20,7 (300)	130 (5.13)	125 (4.94)	125 (4.94)	2,54 (5.6)	R119G12J

[†] dm³/s (scfm) = Standard cubic feet per minute at 7 bar (100 psig) inlet and 5,2 bar (75 psig) no flow secondary setting and 1,4 bar (20 psig) pressure drop.

Options:

R119			J		/**
Port Threads				Engineering Level	
NPT	-			/** Will be entered at Factory	
BSPP	G				
Port Size				Options	
3/4 inch	06			Blank	None
1 inch	08			K	Non-relieving
1-1/2 inch	12			X64*	Fluorocarbon o-rings and diaphragm
Reduced Pressure Range				X71	Non-bleed (for use with electronic controllers)
Air pilot operated	J			X80	Reverse flow

* Brass bottom plug standard with X64 option.

Standard order code shown in bold.

CAUTION:

REGULATOR PRESSURE ADJUSTMENT – The working range of knob adjustment is designed to permit outlet pressures within their full range. Pressure adjustment beyond this range is also possible because the knob is not a limiting device. This is a common characteristic of most industrial regulators, and limiting devices may be obtained only by special design. For best performance, regulated pressure should always be set by increasing the pressure up to the desired setting.

WARNING

Product rupture can cause serious injury. Do not connect regulator to bottled gas. Do not exceed Maximum primary pressure rating.



PNDE3002TCUK

Parker Hi-Flow Filters and Regulators

R119 - 3/4", 1", 1-1/2"

Specifications

Flow capacity*	3/4"	141,6 dm ³ /s, ANR (300 scfm)
	1"	141,6 dm ³ /s, ANR (300 scfm)
	1-1/2"	236 dm ³ /s, ANR (500 scfm)
Operating temperature	4,4°C to 52°C (40°F to 125°F)	
Reduced pressure range	Adjustable to within 0,34 to 0,48 bar (5 to 7 psig) of supply pressure	
Max supply pressure	0 to 20,7 bar (0 to 300 psig)	
Air consumption	Constant bleed from air pilot chamber: approx. 10 scfh (0.17 scfm)	
Port size	3/4, 1, 1-1/2	
Gauge ports (2)	1/4	
Weight	3/4"	2,36 kg (5.2 lb)
	1"	2,36 kg (5.2 lb)
	1-1/2"	2,54 kg (5.6 lb)

(75 psig) no flow secondary setting and 1,4 bar (20 psig) pressure drop.

Material Specifications

Body, ring, top plate	Zinc
Bottom plug, innervalve	Brass
Seals	Buna N

Dimensions mm (inches)

R119G06J,
R119G08J

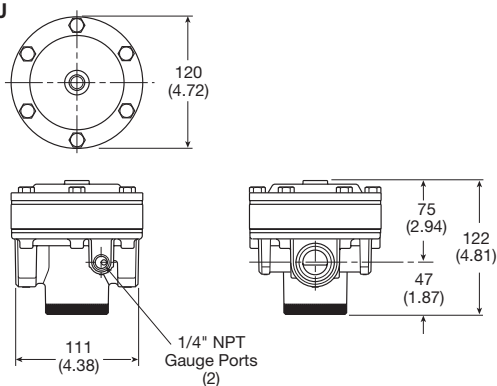

R119G12J

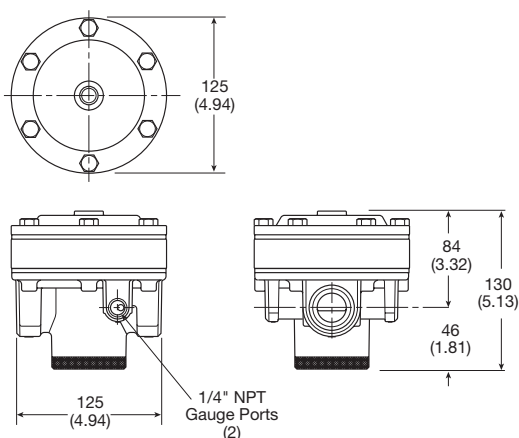

Flow Charts

R119 3/4"
Regulator

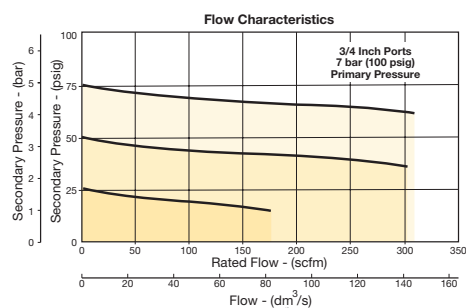

R119 1"
Regulator

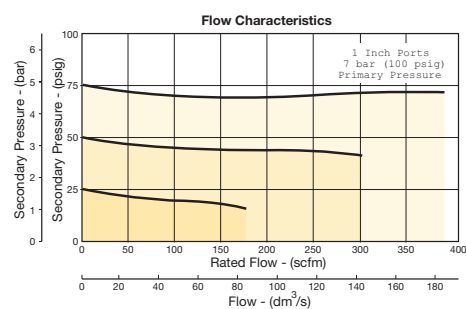

R119 1-1/2"
Regulator

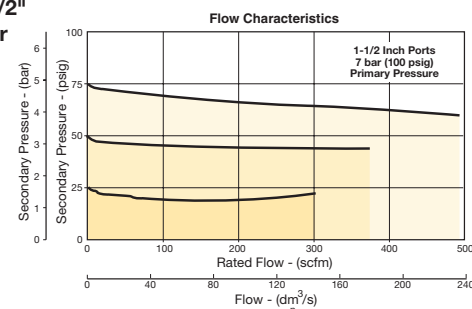

Repair and Service Kits

2" dial face 60 psig (0 to 4.1 bar), gauge	K4520N14060
2" dial face 160 psig (0 to 11.0 bar), gauge	K4520N14160
2" dial face 300 psig (0 to 20.7 bar), gauge	K4520N14300
1-3/4" digital round face 160 psig (0 to 11.0 bar), gauge	K4517N14160D
Non-relieving diaphragm, valve assembly (3/4", 1")	RK118X20B
Non-relieving diaphragm, valve assembly (1-1/4", 1-1/2")	RK118X20D
Relieving diaphragm, valve assembly (3/4", 1")	RK119X20B
Relieving diaphragm, valve assembly (1-1/4", 1-1/2")	RK119X20D

For Fluorocarbon Repair Kits, add X64 to Kit Number suffix.



Pilot Operated Regulators - R119

Symbols

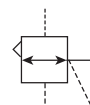

- Adapted for control by a remote or distant small pilot regulator. Ideal for maximum capacity requirements in applications where units are not readily accessible
- High flow performance featuring rugged design for the most demanding applications
- Ideal for those installations calling for constant pressure with wide variation in flow
- Piston operated design with balanced poppet and dual constant bleed for quick and accurate regulation
- 2" ports (BSPP, NPT)

Order Code for Ordering:

Port size	Description (0-125 psig reduced pressure)	Flow* dm ³ /s (scfm)	Max. bar (psig)	Height mm (inches)	Width mm (inches)	Depth mm (inches)	Weight kg (lb)	Part number
2"	Without gauge, relieving,	850 (1800)	20,7 (300)	276 (10.87)	185 (7.31)	168 (6.63)	6,8 (15)	R119G16J

* dm³/s (scfm) = Standard cubic feet per minute at 7 bar (100 psig) inlet and 5,2 bar (75 psig) no flow secondary setting and 1,4 bar (20 psig) pressure drop.

Options:

R119			J					
<table border="1"> <tr><th>Port Threads</th></tr> <tr><td>NPT -</td></tr> <tr><td>BSPP G</td></tr> </table>		Port Threads	NPT -	BSPP G	<table border="1"> <tr><th>Port Size</th></tr> <tr><td>2 inch 16</td></tr> </table>		Port Size	2 inch 16
Port Threads								
NPT -								
BSPP G								
Port Size								
2 inch 16								
<table border="1"> <tr><th>Reduced Pressure Range</th></tr> <tr><td>Air pilot operated J</td></tr> </table>		Reduced Pressure Range	Air pilot operated J					
Reduced Pressure Range								
Air pilot operated J								

NOTE: Non-relieving not available. Standard order code shown in bold.

CAUTION:

REGULATOR PRESSURE ADJUSTMENT – The working range of knob adjustment is designed to permit outlet pressures within their full range. Pressure adjustment beyond this range is also possible because the knob is not a limiting device. This is a common characteristic of most industrial regulators, and limiting devices may be obtained only by special design. For best performance, regulated pressure should always be set by increasing the pressure up to the desired setting.

WARNING
Product rupture can cause serious injury. Do not connect regulator to bottled gas. Do not exceed Maximum primary pressure rating.



PNDE3002TCUK

Parker Hi-Flow Filters and Regulators

R119 - 2"

Specifications

Flow capacity†	2"	850 dm ³ /s, ANR (1800 scfm)
Operating temperature		4,4°C to 52°C (40°F to 125°F)
Reduced pressure range		Adjustable to within 0,34 to 0,48 bar (5 to 7 psig) of supply pressure
Max supply pressure		0 to 20,7 bar (0 to 300 psig)
Air consumption		Constant bleed from air pilot chamber: approx. 10 scfh (0.17 scfm) Reduced pressure: approx. 10 scfh (0.17 scfm)
Port size		2
Gauge ports (2)		
Can be used for full flow		1/4
High pressure outlet for pilot		1/4
Weight	2"	6,8 kg (15 lb)

(75 psig) no flow secondary setting and 1,4 bar (20 psig) pressure drop.

Material Specifications

Body, piston	Aluminum
Seals	Buna N
Innervolve	Brass & stainless

Dimensions mm (inches)

R119G16J

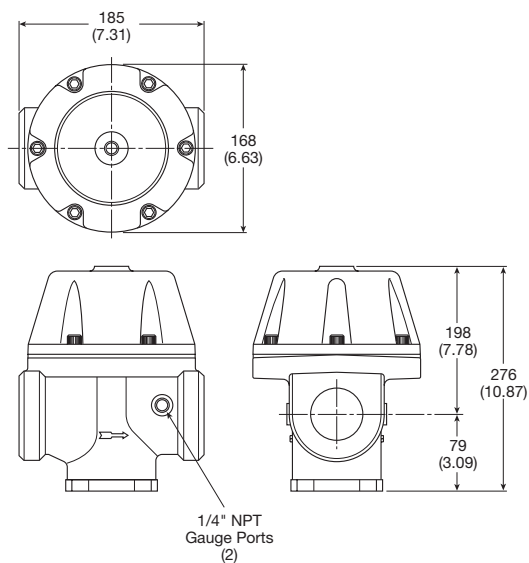

Flow Charts

R119 2" Regulator

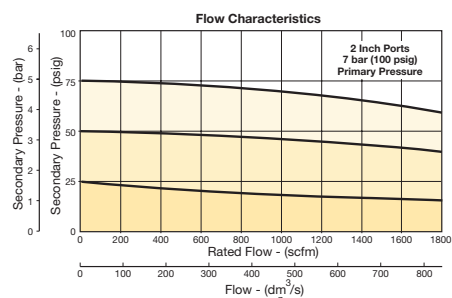

Repair and Service Kits

2" dial face 60 psig (0 to 4.1 bar), gauge	K4520N14060
2" dial face 160 psig (0 to 11.0 bar), gauge	K4520N14160
2" dial face 300 psig (0 to 20.7 bar), gauge	K4520N14300
1-3/4" digital round face 160 psig (0 to 11.0 bar), gauge	K4517N14160D
Piston type regulation (2", 2-1/2")	RK119G

Parker Hannifin Corporation
Electric Motion and Pneumatic Division Europe
Robert-Bosch-Strasse 22
77656 Offenburg
Germany
www.parker.com

PNDE3002TCUK 03/2024

Your Local Authorized Parker Distributor

© 2024 Parker Hannifin Corporation

