



Stainless Steel Valves

For Life sciences, Harsh Environments,
Food & Healthy Beverage Dispensing



ENGINEERING YOUR SUCCESS.

Parker Fluid Control Division Europe - FCDE

Parker Hannifin

Parker Hannifin is the world's leading diversified manufacturer of motion and control technologies and systems, providing precision-engineered solutions for a wide variety of commercial, mobile, industrial, life science and aerospace markets.

The company's products are vital to virtually everything that moves or requires control, including the manufacture and processing of raw materials, durable goods, infrastructure development and all forms of transport.



Fluid Control Division Europe

The Fluid Control Division in Europe (FCDE) is a division of Parker Hannifin, the global leader in motion and control technologies.

FCDE core competences are the development and manufacturing of an extremely diverse range of fluid control products, including solenoid valves and pressure regulators.

Parker Fluidic Solutions (PFS) is a global designer and manufacturer of bespoke integrated system solutions. Renowned globally for solutions in high technology, fluid and motion control utilising advanced design and manufacturing techniques. PFS is focused on incorporating the best of Parker products into solutions designed for you.

History

Parker FCDE has been a leading player in the manufacturing and development of solenoid valve technologies for over 60 years, with continuous research and development bringing innovative solutions to the marketplace, for example leading the way in the utilisation of synthetic ruby for critical water applications or the unsurpassed reliability and precision of our pressure regulators. The expertise accumulated and developed through the years is evident in the superior quality of FCDE solutions.

Markets







Our products and solutions are typically designed for markets including Industrial Equipment, Industrial Automation, Mobile, Transportation, Life Sciences, Beverage dispensing and for Fluid and Process Control.

Benefits

The modular concept of our products, having separate solenoid valves and electrical parts, provides the customer with increased flexibility by allowing numerous combinations. This additional flexibility can enable distributors to greater reduce valve inventory levels, whilst retaining the same number of capabilities. Parker also has unrivalled experience in developing customised product solutions complying with the highest technical, environmental, energy and service life requirements.



Table of content

Series	Body	Specifications	Way	Function	Port Size (inch)	Orifice (mm)	Flow Factor Kv(l/min)	MOPD (bar) Maxi	Max Fluid Temp. (°C)	Page
 201LG/202LG/301LG	316L Stainless St.	High corrosion resistance	2/2	Normally Closed	1/8 to 1/2	1.5 to 6.2	1.0 to 10.0	20	180	6-7
				Normally Open	1/4 to 1/2	3.0 to 6.2	4.5 to 10.0	6	140	8
			3/2	Normally Closed	1/8 to 1/4	1.5 to 3.0	1.0 to 4.5	3 to 12	140	9
 121V/122V/133V 131F	303 Stainless St.	Complete range with all functions and including Ruby sealing	2/2	Normally Closed	1/4	1.5 to 5.0	1.5 to 10	2 to 55	180	12
				Normally Open		2.5	3.0	12	120	14
			3/2	Normally Closed		1.0 to 2.5	0.6 to 3.5	2 to 15	180	15
				Universal		1.5 to 2.5	1.5 to 3.5	4 to 10	180	17
	3/2	316L Stainless St.	ATEX versions for piloting solutions	Normally Closed	SB	1.5	1.5	15	100	16
				Universal	1/4 NPT	2.5	3.5	8.5	75	17
 221G	316L Stainless St.	Large flow valves for pressure up to 16 bar	2/2	Normally Closed	3/8 to 1	15 to 25	65 to 170	10 to 20	140	20-21
 Liquipure®	305 Stainless St.	Include NSF certified offering	2/2	Normally Closed	SB	1.5 to 5	1.3 to 7.2	3 to 20	140	24
				Normally Closed	SB	1.5 to 5	1.3 to 7.2	2 to 14	140	25-26
			3/2	Universal	SB	1.5 to 3	1.4 to 3.3	2 to 9.5	140	27
 501C	303 Stainless St.	FKM FDA approved for healthy beverage dispensing	2/2	Normally Closed	1/8 to 1/4	1.5 to 2.5	1.1 to 2.5	12-14	140	31
 X	316L Stainless St.	Solutions for actuators piloting	3/2	Universal	1/4 NPTF	6	9	12	65	34
 PA Angle Seat valve	316L Stainless St. (304 Stainless St. or Aluminium Actuator)	Air operated valves offering high flow for slurry fluids	2/2	Normally Closed OVER Seat	3/8 to 2-1/2	13 to 65	78 to 1167	16	180	38
				Normally Open OVER Seat		13 to 45	78 to 833	16	180	40
				Normally Closed UNDER Seat	3/4 to 2	13 to 45	78 to 833	16	180	41
 Index	Coil Range for Stainless Steel Solenoid Valves									45



WARNING - USER RESPONSIBILITY

FAILURE OR IMPROPER SELECTION OR IMPROPER USE OF THE PRODUCTS DESCRIBED HEREIN OR RELATED ITEMS CAN CAUSE DEATH, PERSONAL INJURY AND PROPERTY DAMAGE.

• This document and other information from Parker-Hannifin Corporation, its subsidiaries and authorized distributors provide product or system options for further investigation by users having technical expertise.

• The user, through its own analysis and testing, is solely responsible for making the final selection of the system and components and assuring that all performance, endurance, maintenance, safety and warning requirements of the application are met. The user must analyze all aspects of the application, follow applicable industry standards, and follow the information concerning the product in the current product catalog and in any other materials provided from Parker or its subsidiaries or authorized distributors.

• To the extent that Parker or its subsidiaries or authorized distributors provide component or system options based upon data or specifications provided by the user, the user is responsible for determining that such data and specifications are suitable and sufficient for all applications and reasonably foreseeable uses of the components or systems.

201/202/301LG Series

Product Description

High grade material and corrosion resistant 201, 202, 301LG Valve Series is a complete range of 2 way and 3 way valves, direct acting, normally close and normally open.

This new range of solenoid valves, having AISI 316L grade stainless steel body, is the right answer for a wide range of applications in Food & Beverage Industry, Process industry, Wastewater treatment appliances, Marine, high temperature steam applications in aggressive environments or with aggressive media.

FFKM seal is available in order to increase mechanical, high temperature and aggressive media resistance for the most specific and demanding fluid control applications.

Thanks to the modular concept, a wide range of electrical parts can be used including ATEX, IP67, H class, reduced power, UL or VDE approved.

This selection of valves is NSF certified with mechanical ATEX approval available.



Applications

Market of interest:

- Life Sciences
- Food & Beverage Processing
- Commercial Equipment
- Industrial equipment
- Waste Water treatment

Typical applications:

- Water purification and preparation devices
- Food & Beverage processing, Healthy Beverage Dispense equipment
- Demineralized water shut off, cooling of medical and surgical devices
- Dishwasher disinfectors, Laboratory and high end hot steam sterilizers
- Compatible aggressive liquids shut-off
- Ammonia (with silver shading ring version)

Benefits

The most valuable features you will find in this product range:

- High grade corrosion resistant valve body, AISI 316L
- NSF certified references
- FFKM seal option for superior endurance in heavy duty conditions
- Modular concept: a wide range of electrical parts can be used with this family, including ATEX, low power, IP67, UL/VDE approved
- Robust and solid design



General Description

Materials in contact with the fluid

Valve Body & Seat:

AISI 316L Stainless Steel

Tube assembly:

AISI 303 Stainless Steel

Plungers:

AISI 430F Stainless Steel

Springs:

AISI 302 Stainless Steel

Seals:

FKM FDA, FFKM

Shading ring:

Copper: standard

Silver: according to notes

Installation

The valves can be mounted in any position. It is however recommended to install them with the coil in vertical position above the body.

Media

These valves have been developed to achieve the best performances with a wide range of media.

Coil

A wide range of coils can be used with this range. The complete coil range is described in pages 45 to 69.



Temperature

The ambient temperature range of the valve is -10°C to +50°C. For ATEX environments, temperature can be limited by the max ambient temperature of the coil. See coil pages.

How to Order

A complete solenoid valve is composed by 2 elements: the **valve body** and the **coil**. 201LG Series pressure vessel is supplied with the standard housing integrated. Standard housing is composed by washer, nut and nameplate.

Step 1: Select the valve body reference needed. **Example: 301LG2NVG7**

Step 2: According the coil group, select coil + voltage code from page 45. **Example: D5C**

Step 3: Define the complete assembly numbering system. **Example: 301LG2NVG7D5C**

Step 4: Please note that you can order the plug separately if not included with the coil.

Example: 600003PLUG. Please check the coil range pages for more details.



2/2

201LG Series

High corrosion resistant valves

Direct Operated - Port size from 1/8" to 1/4" and orifice from 1.5mm to 3.0mm



316L Stainless St.

Pipe Mounting

Normally Closed

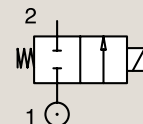

Port Size	Orifice Ø	Flow Factors		Operating Pressure Differential			Fluid Temperature		Seat Seal	Parker Valves		Power		Coil Group	Drawing N°
		Kv	KV	Min.	Max. (MOPD)	Min.	Max.	Valve Ref.		Coil Ref.	AC W	DC W			
1/8"	1.5	1.0	0.06	0	16	7	-10	140	FKM	201LG1GVG2	DF	2	2.5	1.1/1.3	1
	1.5	1.0	0.06	0	20	10	-10	140	FKM	201LG1GVG2	DG	4	5	1.1/1.3	1
	2.5	2.3	0.14	0	8	3	-10	140	FKM	201LG1LVG2	DF	2	2.5	1.1/1.3	1
1/4"	2.5	2.3	0.14	0	10	6	-10	140	FKM	201LG1LVG2	DG	4	5	1.1/1.3	1
	1.5	1.0	0.06	0	20	10	-10	140	FKM	201LG2GVG2	DG	4	5	1.1/1.3	1
	2.5	2.3	0.14	0	8	3	-10	140	FKM	201LG2LVG2	DF	2	2.5	1.1/1.3	1
	2.5	2.3	0.14	0	10	4	-10	140	FKM	201LG2LVG2	DG	4	5	1.1/1.3	1

Notes :

Nominal Pressure = 40 bar

All the references listed in this chart are NSF certified and use FDA compliant seals materials.

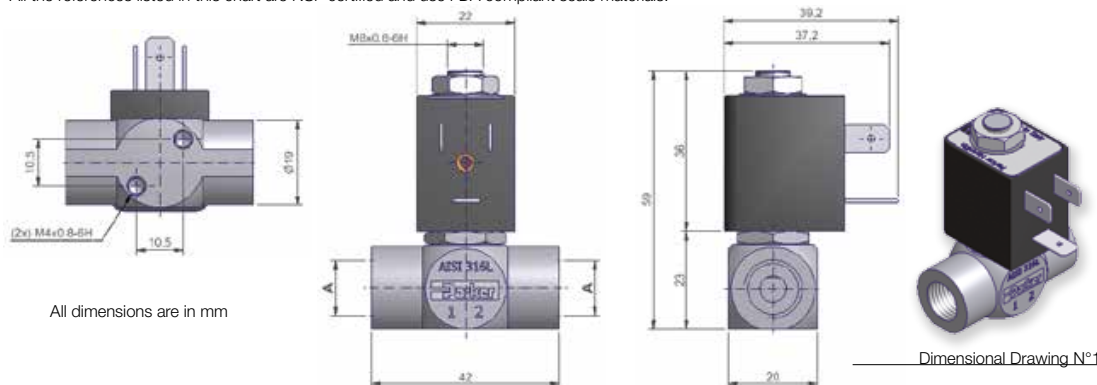

All dimensions are in mm

Dimensional Drawing N°1

	Port Size A	Orifice mm	kv L/min	MOPD bar	Fluid Temp. °C	Amb. Temp. °C
From	1/8"	1.5	1.0	6	-10	-10
To	1/4"	2.5	2.3	20	140	50

316L Stainless St.

Pipe Mounting

Normally Closed

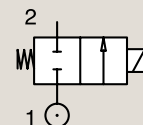

Port Size	Orifice Ø	Flow Factors		Operating Pressure Differential			Fluid Temperature		Seat Seal	Parker Valves		Power		Coil Group	Drawing N°
		Kv	KV	Min.	Max. (MOPD)	Min.	Max.	Valve Ref.		Coil Ref.	AC W	DC W			
1/4"	1.5	1.0	0.06	0	20	15	-10	180	FFKM	201LG2GKG7A	D5	8	9	2.0/24.0	2
	3.0	4.5	0.27	0	9	5	-10	180	FFKM	201LG2NKG7A	D5	8	9	2.0/24.0	2
	3.0	4.5	0.27	0	20	8	-10	180	FFKM	201LG2NKG7A	DM	14	14	2.0/24.0	2
	3.0	4.5	0.27	0	9	5	-10	140	FKM	201LG2NVG7	D5	8	9	2.0/24.0	2
	3.0	4.5	0.27	0	20	8	-10	140	FKM	201LG2NVG7	DM	14	14	2.0/24.0	2
	3.0	4.5	0.27	0	9	5	-10	140	FKM	201LG2NVG7A	D5	8	9	2.0/24.0	2

Notes :

1. With silver shading ring

Nominal Pressure = 40 bar

All the references listed in this chart are NSF certified and use FDA compliant seals materials.



2/2

201LG Series

High corrosion resistant valves

Direct Operated - Port size from 1/4" to 1/2" and orifice from 4.0mm to 6.2mm



316L Stainless St.

Pipe Mounting

Normally Closed

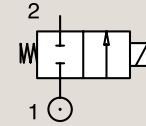

Port Size	Orifice Ø	Flow Factors		Operating Pressure Differential			Fluid Temperature		Seat Seal	Parker Valves		Power		Coil Group	Drawing N°
		Kv	KV	Min.	Max. (MOPD)		Min.	Max.		Valve Ref.	Coil Ref.	AC W	DC W		
BSP	mm	l/min	m³/h	Bar	AC bar	DC bar	°C	°C							
1/4"	4.0	7.0	0.42	0	10	4	-10	180	FFKM	201LG2QKG7A	DM	14	14	2.0/24.0	2
	4.0	7.0	0.42	0	5	3	-10	140	FKM	201LG2QVG7	D5	8	9	2.0/24.0	2
	4.0	7.0	0.42	0	10	4	-10	140	FKM	201LG2QVG7	DM	14	14	2.0/24.0	2
	4.0	7.0	0.42	0	5	3	-10	140	FKM	201LG2QVG7A	D5	8	9	2.0/24.0	2
	4.0	7.0	0.42	0	10	4	-10	140	FKM	201LG2QVG7A	DM	14	14	2.0/24.0	2
	5.0	8.0	0.48	0	3	2	-10	180	FFKM	201LG2SKG7A	D5	8	9	2.0/24.0	2
	5.0	8.0	0.48	0	8	2.5	-10	180	FFKM	201LG2SKG7A	DM	14	14	2.0/24.0	2
	5.0	8.0	0.48	0	3	2	-10	140	FKM	201LG2SVG7	D5	8	9	2.0/24.0	2
	5.0	8.0	0.48	0	8	2.5	-10	140	FKM	201LG2SVG7	DM	14	14	2.0/24.0	2
	5.0	8.0	0.48	0	3	2	-10	140	FKM	201LG2SVG7A	D5	8	9	2.0/24.0	2
3/8"	5.0	8.0	0.48	0	8	2.5	-10	140	FKM	201LG2SVG7A	DM	14	14	2.0/24.0	2
	5.0	8.0	0.48	0	3	2	-10	180	FFKM	201LG3SKG7	D5	8	9	2.0/24.0	2
	5.0	8.0	0.48	0	8	2.5	-10	180	FFKM	201LG3SKG7A	DM	14	14	2.0/24.0	2
	5.0	8.0	0.48	0	3	2	-10	140	FKM	201LG3SVG7	D5	8	9	2.0/24.0	2
	5.0	8.0	0.48	0	8	2.5	-10	140	FKM	201LG3SVG7	DM	14	14	2.0/24.0	2
	5.0	8.0	0.48	0	3	2	-10	140	FKM	201LG3SVG7A	D5	8	9	2.0/24.0	2
	5.0	8.0	0.48	0	8	2.5	-10	140	FKM	201LG3SVG7A	DM	14	14	2.0/24.0	2
	6.2	10.0	0.60	0	1.5	0.5	-10	180	FFKM	201LG3UKG7A	D5	8	9	2.0/24.0	2
	6.2	10.0	0.60	0	4	1.5	-10	180	FFKM	201LG3UKG7A	DM	14	14	2.0/24.0	2
	6.2	10.0	0.60	0	1.5	0.5	-10	140	FKM	201LG3UVG7	D5	8	9	2.0/24.0	2
1/2"	6.2	10.0	0.60	0	4	1.5	-10	140	FKM	201LG3UVG7	DM	14	14	2.0/24.0	2
	6.2	10.0	0.60	0	1.5	0.5	-10	140	FKM	201LG3UVG7A	D5	8	9	2.0/24.0	2
	6.2	10.0	0.60	0	4	1.5	-10	140	FKM	201LG3UVG7A	DM	14	14	2.0/24.0	2
	5.0	8.0	0.48	0	3	2	-10	180	FFKM	201LG4SKG7	D5	8	9	2.0/24.0	2
	5.0	8.0	0.48	0	8	2.5	-10	180	FFKM	201LG4SKG7A	DM	14	14	2.0/24.0	2
	5.0	8.0	0.48	0	3	2	-10	140	FKM	201LG4SVG7	D5	8	9	2.0/24.0	2
	5.0	8.0	0.48	0	8	2.5	-10	140	FKM	201LG4SVG7	DM	14	14	2.0/24.0	2
	5.0	8.0	0.48	0	3	2	-10	140	FKM	201LG4SVG7A	D5	8	9	2.0/24.0	2
	5.0	8.0	0.48	0	8	2.5	-10	140	FKM	201LG4SVG7A	DM	14	14	2.0/24.0	2
	6.2	10.0	0.60	0	1.5	0.5	-10	180	FFKM	201LG4UKG7A	D5	8	9	2.0/24.0	2
6.2	10.0	0.60	0	4	1.5	-10	180	FFKM	201LG4UKG7A	DM	14	14	2.0/24.0	2	
6.2	10.0	0.60	0	1.5	0.5	-10	140	FKM	201LG4UVG7	D5	8	9	2.0/24.0	2	
6.2	10.0	0.60	0	4	1.5	-10	140	FKM	201LG4UVG7	DM	14	14	2.0/24.0	2	
6.2	10.0	0.60	0	1.5	0.5	-10	140	FKM	201LG4UVG7A	D5	8	9	2.0/24.0	2	
6.2	10.0	0.60	0	4	1.5	-10	140	FKM	201LG4UVG7A	DM	14	14	2.0/24.0	2	

Notes :

- 1. With silver shading ring
- Nominal Pressure = 40 bar
- All the references listed in this chart are NSF certified and use FDA compliant seals materials.

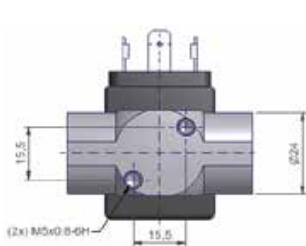

All dimensions are in mm

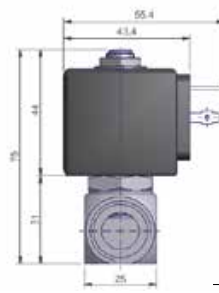
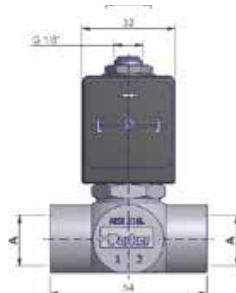

Dimensional Drawing N°2

	Port Size A	Orifice mm	kv L/min	MOPD bar	Fluid Temp. °C	Amb. Temp. °C
From	1/4"	1.5	1	2	-10	-10
To	1/2"	6.2	10	20	140	50



2/2

202LG Series

High corrosion resistant valves

Direct Operated - Port size from 1/4" to 1/2" and orifice from 3.0mm to 6.2mm



316L Stainless St.

Pipe Mounting

Normally Open

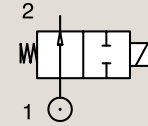

Port Size	Orifice Ø	Flow Factors		Operating Pressure Differential			Fluid Temperature		Seat Seal	Parker Valves		Power		Coil Group	Drawing N°
		Kv l/min	KV m³/h	Min. Bar	Max. (MOPD) AC bar	DC bar	Min. °C	Max. °C		Valve Ref.	Coil Ref.	AC W	DC W		
1/4"	3.0	4.5	0.27	0	6	6	-10	140	FKM	202LG2NVG7	D5	8	9	2.0/24.0	1
	5.0	8.0	0.48	0	3	3	-10	140	FKM	202LG2SVG7	D5	8	9	2.0/24.0	1
1/2"	5.0	8.0	0.48	0	3	3	-10	140	FKM	202LG4SVG7	D5	8	9	2.0/24.0	1
	6.2	10.0	0.60	0	1	1	-10	140	FKM	202LG4UVG7	D5	8	9	2.0/24.0	1

Notes :

Nominal Pressure = 40 bar

All the references listed in this chart are NSF certified and use FDA compliant seals materials.

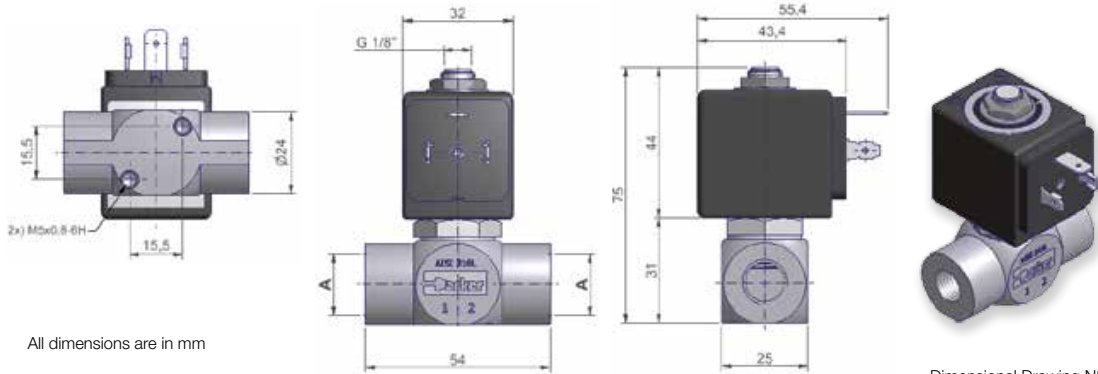

All dimensions are in mm

Dimensional Drawing N°1

	Port Size A	Orifice mm	kv L/min	MOPD bar	Fluid Temp. °C	Amb. Temp. °C
From	1/4"	3.0	4.5	1	-10	-10
To	1/2"	6.2	10	6	140	50



3/2

301LG Series

High corrosion resistant valves

Direct Operated - Port size from 1/8" to 1/4" and orifice from 1.5mm to 3.0mm



316L Stainless St.

Pipe Mounting

Normally Closed

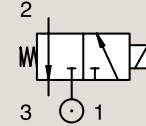

Port Size	Orifice Ø	Flow Factors		Operating Pressure Differential			Fluid Temperature		Seat Seal	Parker Valves		Power		Coil Group	Drawing N°
		Kv l/min	KV m³/h	Min. Bar	Max. (MOPD) AC bar	DC bar	Min. °C	Max. °C		Valve Ref.	Coil Ref.	AC W	DC W		
1/8"	1.5	1.0	0.06	0	8	8	-10	140	FKM	301LG1GVG2	DG	4	5	1.1/1.3	2
	2.5	2.3	0.14	0	3	3	-10	140	FKM	301LG1LVG2	DG	4	5	1.1/1.3	2
1/4"	1.5	1.0	0.06	0	8	8	-10	140	FKM	301LG2GVG2	DG	4	5	1.1/1.3	2
	1.5	1.0	0.06	0	12	12	-10	140	FKM	301LG2GVG7	D5	8	9	2.0/24.0	3
	2.5	2.3	0.14	0	3	3	-10	140	FKM	301LG2LVG2	DG	4	5	1.1/1.3	3
	3.0	4.5	0.27	0	4	4	-10	140	FKM	301LG2NVG7	D5	8	9	2.0/24.0	3

Notes :

Nominal Pressure = 40 bar

All the references listed in this chart are NSF certified and use FDA compliant seals materials.

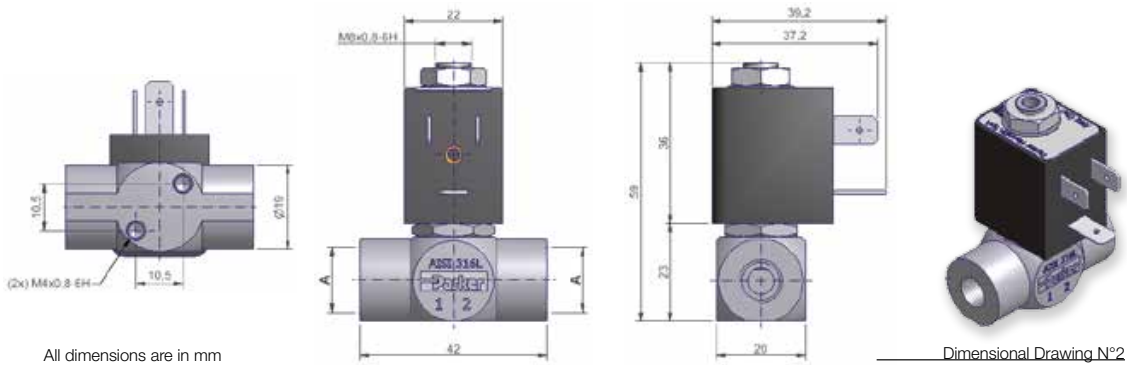

All dimensions are in mm

Dimensional Drawing N°2

	Port Size A	Orifice mm	kv L/min	MOPD bar	Fluid Temp. °C	Amb. Temp. °C
From	1/8"	1.5	1.0	3	-10	-10
To	1/4"	2.5	2.3	8	140	50

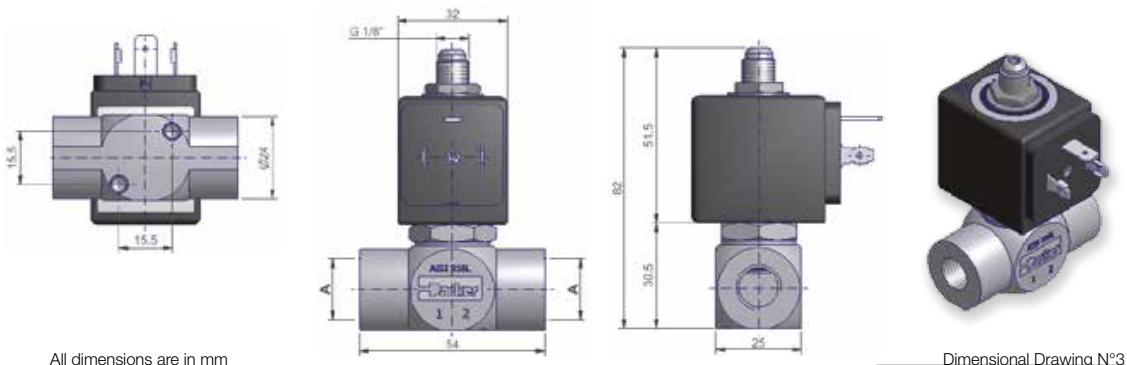

All dimensions are in mm

Dimensional Drawing N°3

	Port Size A	Orifice mm	kv L/min	MOPD bar	Fluid Temp. °C	Amb. Temp. °C
From	1/4"	1.5	1	4	-10	-10
To	1/4"	3.0	4.5	12	140	50



121V / 122V / 133V / 131F Series

Product Description

This complete range with 2 ways and 3 ways constructions offers a large choice of sealing. These valves can be combined with a wide range of electrical parts including ATEX zone 0.



Applications

Market of interest:

- Life Sciences
- Food & Beverage Processing
- Commercial Equipment
- Industrial equipment
- Waste Water treatment

Typical applications:

- Water purification and preparation devices
- Dishwasher disinfectors, Laboratory and high end hot steam sterilizers
- Compatible aggressive liquids shut-off
- Ammonia (with silver shading ring version in option)

Benefits

The most valuable features you will find in this product range:

- FFKM seal option for superior endurance in heavy duty conditions
- Modular concept: a wide range of electrical parts can be used with this family, including ATEX, low power, IP67, UL/VDE approved
- Robust and solid design
- Large choice of sealing
- Selection for ATEX zone 0 applications
- Universal 3 ways construction available



General Description

Materials in contact with the fluid

Valve Body & Seat:

AISI 303 Stainless Steel (316L for U133V)

Other parts:

Stainless steel

Plunger:

Ferritic stainless steel

Seals (according versions):

FKM, PTFE, RUBY, PUR

Shading ring:

Copper: standard

Silver: according to notes

Installation

The valves can be mounted in any position. It is however recommended to install them with the coil in vertical position above the body. Please check compability with materials.

Media

These valves have been developed to achieve the best performances with a wide range of media. Check compatibility with material.



Air



Steam



Water



Oil

Temperature

For the 121V: The ambient temperature range of the valve is -10°C to $+50^{\circ}\text{C}$.

For the 121V5x97 and 131V5x97 series: The ambient temperature range of the valve is -20°C to $+65^{\circ}\text{C}$.

For the U133Vx97: The ambient temperature range of the valve is -25°C to $+50^{\circ}\text{C}$.

For ATEX environments: temperature can be limited by the max ambient temperature of the coil. See coil pages.

Coils

A wide range of coils can be used with this range.

The complete coil range is described in pages 45 to 69.

How to Order

A complete solenoid valve is composed by 3 elements: the **valve body**, the **housing** and the **coil**.

Step 1: Select the valve body reference needed. **Example: 121V5706**

Step 2: Select the housing depending on the protection level. **Example: 2995**

Step 3: Select the coil ref. + voltage code. Find the voltage code in coil pages starting from page 45
Example: 481865C2

Step 5: The complete assembly numbering system is : **121V5706-2995-481865C2**

Step 4: Accessories

Din Plug Connector according to DIN EN 175301-803 Form A **48658640** (batch size = 25)

2/2

121V Series

High corrosion resistant valves

Direct Operated - Port size 1/4" and orifice from 1.5mm to 5.0mm



303 Stainless St.

Pipe Mounting

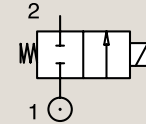

Normally Closed

Port Size	Orifice Ø mm	Flow Factors		Operating Pressure Differential			Fluid Temperature		Seat Seal	Parker Valves			IS	ATEX Zone	Protection Mode	Power		Coil Group	Dwg N°
		Kv l/min	KV m³/h	Min. Bar	Max. (MOPD) AC bar	DC bar	Min. °C	Max. °C		Valve Ref.	Housing Ref.	Coil Ref.				AC W	DC W		
1.5	1.5	0.09	0	20	20	-10	100	FKM	121V5406 ₁	2995	481865	-	-	-	8	9	2.0	8116	
1.5	1.5	0.09	0	20	20	-10	120	FKM	121V5406 ₂	4270	481000	-	-	-	8	8	2.0	8116	
1.5	1.5	0.09	0	60	25	0	100	Ruby	121V5463 ₁₂	2995	481865	-	-	-	8	9	2.0	8116	
1.5	1.5	0.09	0	75	30	0	130	Ruby	121V5463 ₁₂	4270	481000	-	-	-	8	8	2.0	8116	
1.5	1.5	0.09	0	100	55	0	140	Ruby	121V5463 ₁₂	4270	486265	-	-	-	14	14	2.0	8116	
1.5	1.5	0.09	0	-	8	-20	75	PUR	121V5497 ₁₃	2995	482740	-	-	-	-	1.6	6.0/8.0	8116	
1.5	1.5	0.09	0	-	8	-20	65	PUR	121V5497 ₁₃	2995	496125	-	2-22	Ex nAc nCc IIC T5/T6	-	1.6	6.0/8.0	8116	
1.5	1.5	0.09	0	10	10	-20	75	PUR	121V5497 ₁₃	-	495900	-	1-21	Ex db mb IIC T4 to T6	3	2	6.0/8.0	8024	
1.5	1.5	0.09	0	-	10	-20	75	PUR	121V5497 ₁₃	-	495910	√	0-20	Ex ia IIC T4 to T6	-	0.3-1.2	6.0/8.0	8024	
2.5	3.5	0.21	0	14	7	-10	100	FKM	121V5706 ₁	2995	481865	-	-	-	8	9	2.0	8116	
2.5	3.5	0.21	0	14	9	-10	120	FKM	121V5706 ₁	4270	481000	-	-	-	8	8	2.0	8116	
2.5	3.5	0.21	0	14	14	-10	120	FKM	121V5706 ₁	4270	486265	-	-	-	14	14	2.0	8116	
2.5	3.5	0.21	0	28	10	0	100	Ruby	121V5763 ₁₂	2995	481865	-	-	-	8	9	2.0	8116	
2.5	3.5	0.21	0	34	12	0	130	Ruby	121V5763 ₁₂	4270	481000	-	-	-	8	8	2.0	8116	
2.5	3.5	0.21	0	50	22	0	140	Ruby	121V5763 ₁₂	4270	486265	-	-	-	14	14	2.0	8116	
3.0	4.5	0.27	0	10	7	-10	100	FKM	121V5306 ₁	2995	481865	-	-	-	8	9	2.0	8116	
3.0	4.5	0.27	0	10	8.5	-10	120	FKM	121V5306 ₁	4270	481000	-	-	-	8	8	2.0	8116	
3.0	4.5	0.27	0	10	10	-10	120	FKM	121V5306 ₁	4270	486265	-	-	-	14	14	2.0	8116	
3.0	4.5	0.27	0	20	7	0	100	Ruby	121V5363 ₁₂	2995	481865	-	-	-	8	9	2.0	8116	
3.0	4.5	0.27	0	25	8.5	0	130	Ruby	121V5363 ₁₂	4270	481000	-	-	-	8	8	2.0	8116	
3.0	4.5	0.27	0	36	15	0	140	Ruby	121V5363 ₁₂	4270	486265	-	-	-	14	14	2.0	8116	
1/4"	3.0	3.5	0.21	0	-	2	-20	75	PUR	121V5397 ₁₃	2995	482740	-	-	-	-	1.6	6.0/8.0	8116
3.0	3.5	0.21	0	-	2	-20	65	PUR	121V5397 ₁₃	2995	496125	-	2-22	Ex nAc nCc IIC T5/T6	-	1.6	6.0/8.0	8116	
3.0	3.5	0.21	0	4.5	4	-20	75	PUR	121V5397 ₁₃	-	495900	-	1-21	Ex db mb IIC T4 to T6	3	2	6.0/8.0	8024	
3.0	3.5	0.21	0	-	4.5	-20	75	PUR	121V5397 ₁₃	-	495910	√	0-20	Ex ia IIC T4 to T6	-	0.3-1.2	6.0/8.0	8024	
4.0	7.0	0.42	0	10	4	-10	100	FKM	121V5206 ₁	2995	481865	-	-	-	8	9	2.0	8116	
4.0	7.0	0.42	0	10	5	-10	120	FKM	121V5206 ₁	4270	481000	-	-	-	8	8	2.0	8116	
4.0	7.0	0.42	0	10	10	-10	120	FKM	121V5206 ₁	4270	486265	-	-	-	14	14	2.0	8116	
4.0	7.0	0.42	0	3.5	3.5	0	100	PTFE	121V5212 ₁₂	2995	481865	-	-	-	8	9	2.0	8116	
4.0	7.0	0.42	0	3.5	3.5	0	130	PTFE	121V5212 ₁₂	4270	481000	-	-	-	8	8	2.0	8116	
4.0	7.0	0.42	0	3.5	3.5	0	130	PTFE	121V5212 ₁₂	4270	486265	-	-	-	14	14	2.0	8116	
4.0	7.0	0.42	0	12	4	0	100	Ruby	121V5263 ₁₂	2995	481865	-	-	-	8	9	2.0	8116	
4.0	7.0	0.42	0	15	5	0	130	Ruby	121V5263 ₁₂	4270	481000	-	-	-	8	8	2.0	8116	
4.0	7.0	0.42	0	22	10	0	180	Ruby	121V5263 ₁₂	4270	486265	-	-	-	14	14	2.0	8116	
5.0	10.0	0.60	0	7	2	-10	100	FKM	121V5106 ₁	2995	481865	-	-	-	8	9	2.0	8116	
5.0	10.0	0.60	0	7	2.8	-10	120	FKM	121V5106 ₁	4270	481000	-	-	-	8	8	2.0	8116	
5.0	10.0	0.60	0	7	5	-10	120	FKM	121V5106 ₁	4270	486265	-	-	-	14	14	2.0	8116	
5.0	10.0	0.60	0	2.8	2	0	100	PTFE	121V5112 ₁₂	2995	481865	-	-	-	8	9	2.0	8116	
5.0	10.0	0.60	0	2.8	2.8	0	130	PTFE	121V5112 ₁₂	4270	481000	-	-	-	8	8	2.0	8116	
5.0	10.0	0.60	0	2.8	2.8	0	130	PTFE	121V5112 ₁₂	4270	486265	-	-	-	14	14	2.0	8116	
5.0	10.0	0.60	0	8.5	2	0	100	Ruby	121V5163 ₁₂	2995	481865	-	-	-	8	9	2.0	8116	
5.0	10.0	0.60	0	10	3.5	0	130	Ruby	121V5163 ₁₂	4270	481000	-	-	-	8	8	2.0	8116	
5.0	10.0	0.60	0	14	6.5	0	140	Ruby	121V5163 ₁₂	4270	486265	-	-	-	14	14	2.0	8116	

Notes :

1. With silver shading ring
 2. Valve only compatible with hydraulic oil and neutral liquids
 3. For water, the maximum fluid temperature is +40°C
- The maximum fluid temperature is given for the lower coil class temperature. See coil pages for more details.



121V Series

High corrosion resistant valves

Direct Operated - Port size 1/4" and orifice from 1.0mm to 5.0mm

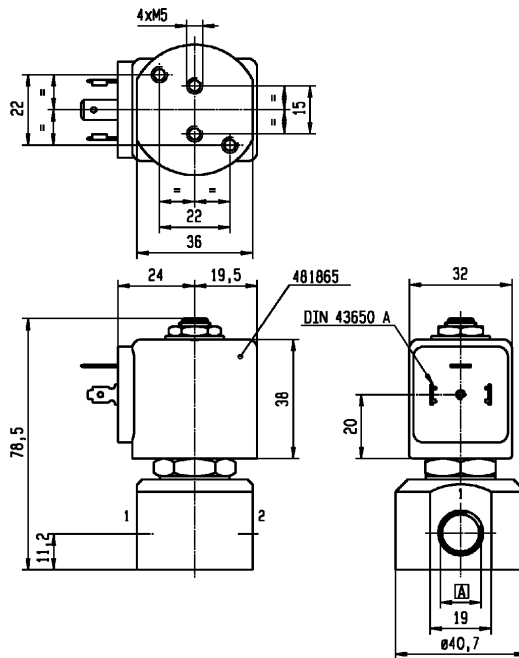

A	G 1/8"
	G 1/4"



Drawing 8116

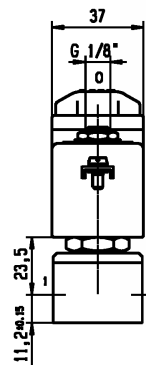
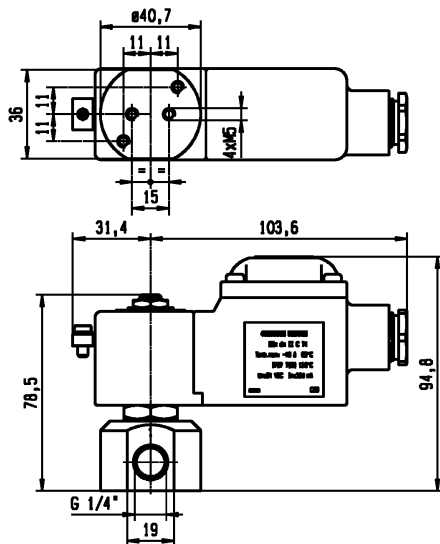

Drawing 8024

2/2

122V Series

High corrosion resistant valves

Direct Operated - Port size 1/4" and orifice 2.5 mm

SIL CE

303 Stainless St.

Pipe Mounting

Normally Open

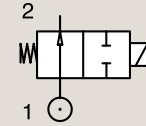

Port Size	Orifice Ø mm	Flow Factors		Operating Pressure Differential			Fluid Temperature		Seat Seal	Parker Valves			IS	ATEX Zone	Protection Mode	Power		Coil Group	Dwg N°
		Kv l/min	KV m³/h	Min. Bar	Max. (MOPD) AC bar	DC bar	Min. °C	Max. °C		Valve Ref.	Housing Ref.	Coil Ref.				AC W	DC W		
1/4"	2.5	3.0	0.18	0	12	12	-30	100	FKM	122V8306	2995	481865	-	-	-	8	9	2.1	8116
	2.5	3.0	0.18	0	12	12	-30	120	FKM	122V8306	4270	481000	-	-	-	8	8	2.1	8116

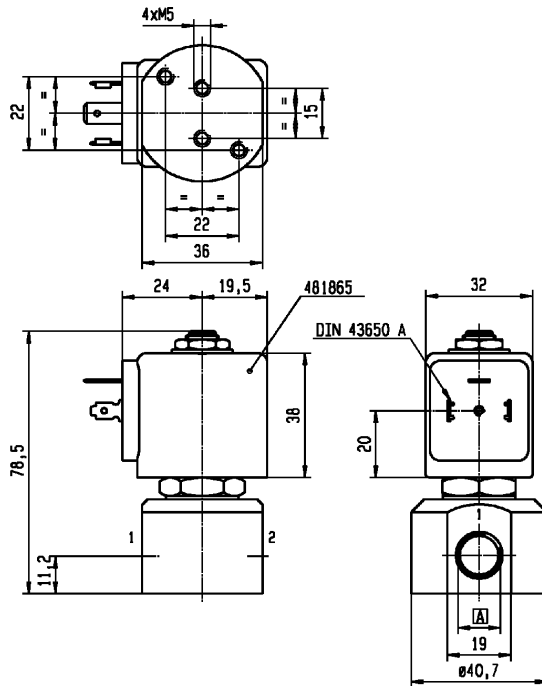

A	G 1/8"
	G 1/4"



Drawing.8116



3/2

131V Series

High corrosion resistant valves

Direct Operated - Port size 1/4" and orifice from 1.0mm to 2.5mm



303 Stainless St.

Pipe Mounting

Normally Closed

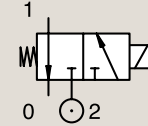

Port Size	Orifice Ø mm	Flow Factors		Operating Pressure Differential			Fluid Temperature		Seat Seal	Parker Valves			IS ATEX Zone	Protection Mode	Power		Coil Group	Dwg N°	
		Kv l/min	KV m³/h	Min. Bar	Max. (MOPD) AC bar DC bar	Min. °C	Max. °C	Valve Ref.		Housing Ref.	Coil Ref.	AC W			DC W				
1/4"	1.0	0.6	0.04	0	-	10	-10	55	FKM	131V5490 ₃	2995	48358001	✓	0-20	Ex ia IIC T6	-	0.5-3	6.0/7.0/8.0	6740
	1.0	0.6	0.04	0	-	10	-10	75	FKM	131V5490 ₃	-	495910	✓	0-20	Ex ia IIC T4 to T6	-	0.3-1.2	6.0/7.0/8.0	8024
	1.5	1.5	0.09	0	15	15	-10	100	FKM	131V5406 ₁	2995	481865	-	-	-	8	9	2.1	6740
	1.5	1.5	0.09	0	15	15	-10	120	FKM	131V5406 ₁	4270	481000	-	-	-	8	8	2.1	6740
	1.5	1.5	0.09	0	15	15	0	100	Ruby	131V5463 ₁₂	2995	481865	-	-	-	8	9	2.0	6740
	1.5	1.5	0.09	0	15	15	0	130	Ruby	131V5463 ₁₂	4270	481000	-	-	-	8	8	2.0	6740
	1.5	1.5	0.09	0	15	15	0	180	Ruby	131V5463 ₁₂	4270	486265	-	-	-	14	14	2.0	6740
	1.5	1.5	0.09	0	-	7	-20	75	PUR	131V5497 ₁	2995	482740	-	-	-	-	1.6	6.0/8.0	6740
	1.5	1.5	0.09	0	-	7	-20	65	PUR	131V5497 ₁	2995	496125	-	2-22	Ex nAc nCc IIC T5/T6	-	1.6	6.0/8.0	6740
	1.5	1.5	0.09	0	7	7	-20	75	PUR	131V5497 ₁	-	495900	-	1-21	Ex db mb IIC T4 to T6	3	2	6.0/8.0	8024
	1.5	1.5	0.09	0	-	7	-20	75	PUR	131V5497 ₁	-	495910	✓	0-20	Ex ia IIC T4 to T6	-	0.3-1.2	6.0/8.0	8024
	2.5	3.5	0.21	0	7	7	-10	120	FKM	131V5306 ₁	2995	481865	-	-	-	8	9	2.0/2.1	6740
	2.5	3.5	0.21	0	7	7	-10	120	FKM	131V5306 ₁	4270	481000	-	-	-	8	8	2.1	6740
	2.5	3.5	0.21	0	7	7	-30	100	Ruby	131V5363 ₁₂	2995	481865	-	-	-	8	9	2.0	6740
	2.5	3.5	0.21	0	7	7	-30	130	Ruby	131V5363 ₁₂	4270	481000	-	-	-	8	8	2.0	6740
	2.5	3.5	0.21	0	7	7	-30	180	Ruby	131V5363 ₁₂	4270	486265	-	-	-	14	14	2.0	6740
	2.5	3.0	0.18	0	-	2	-20	75	PUR	131V5397 ₁	2995	482740	-	-	-	-	1.6	6.0/8.0	6740
	2.5	3.0	0.18	0	-	2	-20	65	PUR	131V5397 ₁	2995	496125	-	2-22	Ex nAc nCc IIC T5/T6	-	1.6	6.0/8.0	6740
	2.5	3.0	0.18	0	2	2	-20	75	PUR	131V5397 ₁	-	495900	-	1-21	Ex db mb IIC T4 to T6	3	2	6.0/8.0	8024
	2.5	3.0	0.18	0	-	2	-20	75	PUR	131V5397 ₁	-	495910	✓	0-20	Ex ia IIC T4 to T6	-	0.3-1.2	6.0/8.0	8024

Notes :

1. With silver shading ring
2. Valve only compatible with hydraulic oil and neutral liquids
3. No shading ring for this version

In this grid the maximum fluid temperature is given for the lower coil class temperature. See coil pages for more details.

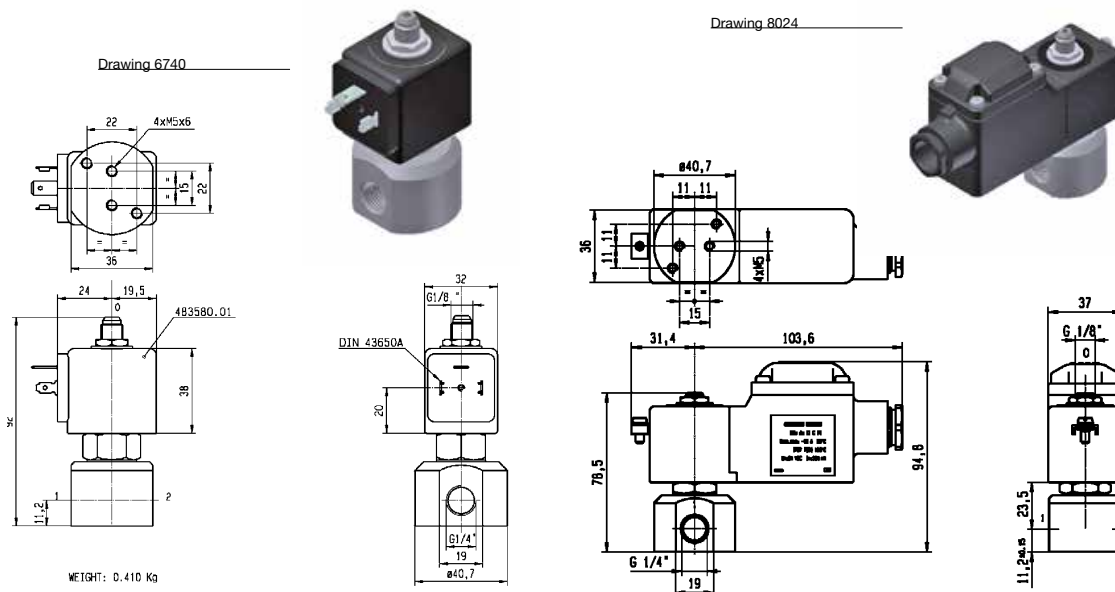

3/2

131F Series

High corrosion resistant valves

Direct Operated - Sub-base mounting and orifice from 1.5mm to 2.5mm



316L Stainless St.

Sub-base Mounting

Normally Closed

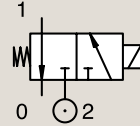

Port Size	Orifice Ø mm	Flow Factors		Operating Pressure Differential			Fluid Temperature		Seat Seal	Parker Valves			IS	ATEX Zone	Protection Mode	Power		Coil Group	Dwg N°
		Kv l/min	KV m³/h	Min. Bar	Max. (MOPD) AC bar	DC bar	Min. °C	Max. °C		Valve Ref.	Housing Ref.	Coil Ref.				AC W	DC W		
SB	1.5	1.5	0.09	0	15	15	-10	100	FKM	131F5406	2995	481865	-	-	-	8	9	2.1	3509

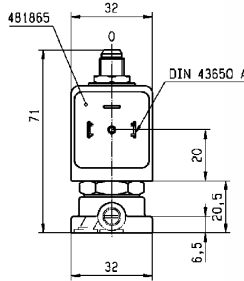
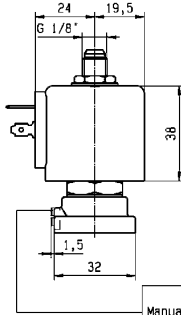
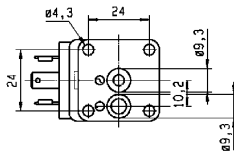

Drawing 3509

OPTION
Manual override
121...131F...50

316L Stainless St.

Sub-base Mounting

Normally Closed

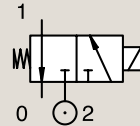

Port Size	Orifice Ø mm	Flow Factors		Operating Pressure Differential			Fluid Temperature		Seat Seal	Parker Valves			IS	ATEX Zone	Protection Mode	Power		Coil Group	Dwg N°
		Kv l/min	KV m³/h	Min. Bar	Max. (MOPD) AC bar	DC bar	Min. °C	Max. °C		Valve Ref.	Housing Ref.	Coil Ref.				AC W	DC W		
SB	2.5	3.5	0.21	0	10	10	-25	65	FKM	U131F5295	-	496560	-	1-21	Ex db mb IIC T4	8	8	9.0/10.1/10.2	8174

Notes :

1. No shading ring for this version

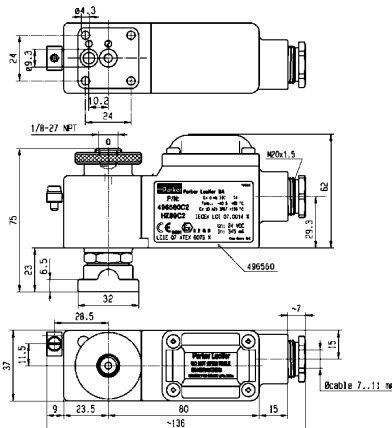

Drawing 8174



3/2

133V Series

High corrosion resistant valves

Direct Operated - Port size 1/4" and orifice from 1.5mm to 2.5mm



303 Stainless St.

Pipe Mounting

Universal

Port Size	Orifice Ø mm	Flow Factors		Operating Pressure Differential			Fluid Temperature		Seat Seal	Parker Valves			IS	ATEX Zone	Protection Mode	Power		Coil Group	Dwg N°
		Kv l/min	KV m³/h	Min. Bar	Max. (MOPD) AC bar	DC bar	Min. °C	Max. °C		Valve Ref.	Housing Ref.	Coil Ref.				AC W	DC W		
1/4"	1.5	1.5	0.09	0	10	10	-10	100	FKM	133V5406 ₁	2995	481865	-	-	-	8	9	2.1	6740
	1.5	1.5	0.09	0	10	10	-10	120	FKM	133V5406 ₁	4270	481000	-	-	-	8	8	2.1	6740
	1.5	1.5	0.09	0	4	4	0	100	Ruby	133V5463 _{1,2}	2995	481865	-	-	-	8	9	2.0	6740
	1.5	1.5	0.09	0	10	10	0	130	Ruby	133V5463 _{1,2}	4270	481000	-	-	-	8	8	2.0	6740
	1.5	1.5	0.09	0	10	10	0	180	Ruby	133V5463 _{1,2}	4270	486265	-	-	-	14	14	2.0	6710
	2.5	3.5	0.21	0	4	4	-10	100	FKM	133V5306 ₁	2995	481865	-	-	-	8	9	2.1	6740
	2.5	3.5	0.21	0	4	4	-10	120	FKM	133V5306 ₁	4270	481000	-	-	-	8	8	2.1	6740
	2.5	3.5	0.21	0	4	4	0	100	Ruby	133V5363 _{1,2}	2995	481865	-	-	-	8	9	2.0	6740
	2.5	3.5	0.21	0	4	4	0	130	Ruby	133V5363 _{1,2}	4270	481000	-	-	-	8	8	2.0	6740
	2.5	3.5	0.21	0	4	4	0	180	Ruby	133V5363 _{1,2}	4270	486265	-	-	-	14	14	2.0	6740

Notes :

1. With silver shading ring
2. Valve only compatible with hydraulic oil and neutral liquids

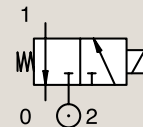

316L Stainless St.

Pipe Mounting

Universal

Port Size	Orifice Ø mm	Flow Factors		Operating Pressure Differential			Fluid Temperature		Seat Seal	Parker Valves			IS	ATEX Zone	Protection Mode	Power		Coil Group	Dwg N°
		Kv l/min	KV m³/h	Min. Bar	Max. (MOPD) AC bar	DC bar	Min. °C	Max. °C		Valve Ref.	Housing Ref.	Coil Ref.				AC W	DC W		
1/4"	2.5	3.5	0.21	0	8.5	8.5	-25	75	FKM	U133V7695	-	492310	-	1-21	Ex eb mb IIC T4/T5	6	6	9.0/10.1	8166
	2.5	3.5	0.21	0	-	8.5	-25	65	FKM	U133V7695	-	49296501	√	0-20	Ex ia IIC T6	-	0.3-2.3	9.0/10.1	8166
	2.5	3.5	0.21	0	-	8.5	-25	65	FKM	U133V7695	-	496565	√	0-20	Ex ia IIC T4 to T6	-	0.8-2.6	9.0/10.1	8166

Notes :

The maximum fluid temperature of this reference is given for the lower class temperature . See coil pages for more details.

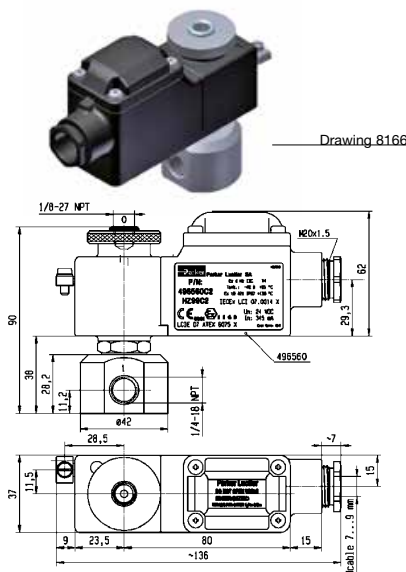
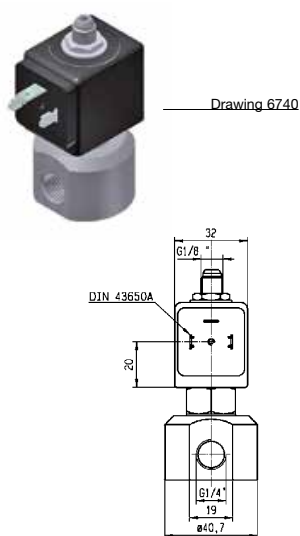
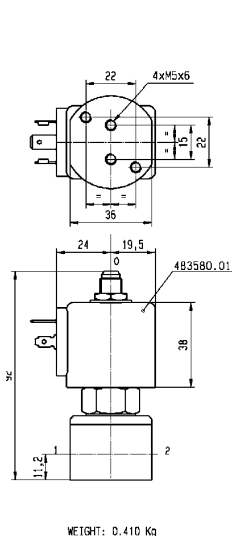
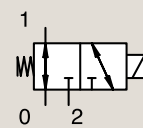

221G Series

Product Description

These 2 ways valves with 316L stainless steel body and FKM sealing offer a large possibility of applications based on a wide chemical compatibility with many fluids and environments.

This range from orifice 15mm to 25mm is suitable for pressure from 0 to 16 bar and can be associated with ATEX coils.



Applications

Market of interest:

- Industrial equipment
- Life Sciences
- Food & Beverage Processing
- Commercial Equipment
- Wastewater treatment

Typical applications:

- Food & Beverage processing
- Dishwasher disinfectors, sterilizers
- Aggressive liquids & environments

Benefits

The 221G anti-corrosive solenoid valve is the most resistant solution for fluid control in even the harshest environment

This stainless steel solenoid valves is the most resistant to corrosion and aggressive chemicals with the largest number of possible electrical connections. It delivers high performance and reliability:

- Longer lifetime (+30% in average)
- Cost efficient (-10% in cost installation)
- Compatible with explosive environment (ATEX certified)



General Description

Materials in contact with fluid

Valve Body, seat, cover & diaphragm holder:

AISI 316L Stainless Steel

Shading ring:

None in standard

Silver for all codes type 221G6x06

Plunger :

Ferritic Stainless Steel

Other parts:

Stainless Steel

CuBe2 for all codes type 221G6x36

Seals:

FKM

Installation

The valves can be mounted in any position. It is however recommended to install them with the coil in vertical position above the body.

Media

These valves have been developed to achieve a wide range of chemical compatibilities with 316L body material and FKM sealing . Check chemical compatibilities with the fluid.



Air



Water



Oil

Temperature

The ambient temperature range of the valve is -10°C to +50°C.

For ATEX environments, temperature can be limited by the max ambient temperature of the coil. See coil pages.

Coils

A wide range of coils can be used with this range.

The complete coil range is described in pages 45 to 69.



How to Order

A complete solenoid valve is composed by 3 elements: the **valve body**, the **housing** and the **coil**.

Step 1: Select the valve body reference needed. **Example: 221G6306**

Step 2: Select the housing depending on the protection level. **Example: 2995**

Step 3: Select the coil ref. + voltage code. Find the voltage code in coil pages starting from page 44
Example: 481865C2

Step 5: The complete assembly numbering system is : **221G6306-2995-481865C2**

Step 4: Accessories

Din Plug Connector according to DIN EN 175301-803 Form A **48658640** (batch size = 25)

Please note: Valve can be ordered according to desired configuration: Valve body and coil separately, Valve body and coil assembled or Valve body, pipe mounting adaptation kit and coil assembled (pipe mounting version)

2/2

221G Series

Valves for dry or lubricated air, neutral gases and liquids
Magnalift - Port size from 3/8" to 1/2" and orifice 15mm



316L Stainless St.

Pipe Mounting

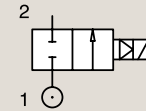

Normally Closed

Port Size	Orifice Ø mm	Flow Factors		Operating Pressure Differential			Fluid Temperature		Seat Seal	Parker Valves			IS	ATEX Zone	Protection Mode	Power		Coil Group	Dwg N°	
		Kv l/min	KV m³/h	Min. Bar	Max. (MOPD) AC bar	DC bar	Min. °C	Max. °C		Valve Ref.	Housing Ref.	Coil Ref.				AC W	DC W			
3/8"	15	65	3.90	0	16	-	0	100	FKM	221G6306	2995	481865	-	-	-	8	-	2.0	3732	
	15	65	3.90	0	-	6	0	60	FKM	221G6306 ₂	2995	492425	-	-	-	-	14	2.0	3732	
	15	65	3.90	0	16	-	0	65	FKM	221G6306	2995	495870	-	2-22	Ex nAc nCc IIC T3/T4	8	-	2.0	3732	
	15	65	3.90	0	16	-	0	120	FKM	221G6306	4538	481000	-	-	-	8	-	2.0	3732	
	15	65	3.90	0	20	7	0	140	FKM	221G6306	4538	486265	-	-	-	14	14	2.0	3732	
	15	65	3.90	0	16	-	0	80	FKM	221G6306	-	495905	-	1-21	Ex db mb IIC T4	8	-	2.0	3732	
	15	65	3.90	0	-	10	-10	100	FKM	221G6336	2995	481865	-	-	-	-	9	2.1	3732	
	15	65	3.90	0	-	10	-10	65	FKM	221G6336	2995	495870	-	2-22	Ex nAc nCc IIC T3/T4	-	9	2.1	3732	
	15	65	3.90	0	10	10	-10	65	FKM	221G6336	-	492070	-	1-21	Ex mb IIC T4/T5	9	8	2.1	3732	
	15	65	3.90	0	10	10	-10	75	FKM	221G6336	-	492190	-	1-21	Ex eb mb IIC T3/T4	11	9	2.1	3732	
	15	65	3.90	0	-	10	-10	80	FKM	221G6336	-	495905	-	1-21	Ex db mb IIC T4	-	8	2.1	3732	
	1/2"	15	65	3.90	0	16	-	0	100	FKM	221G6506	2995	481865	-	-	-	8	-	2.0	3732
		15	65	3.90	0	-	6	0	60	FKM	221G6506 ₂	2995	492425	-	-	-	-	14	2.0	3732
		15	65	3.90	0	16	-	0	65	FKM	221G6506	2995	495870	-	2-22	Ex nAc nCc IIC T3/T4	8	-	2.0	3732
		15	65	3.90	0	16	-	0	120	FKM	221G6506	4538	481000	-	-	-	8	-	2.0	3732
15		65	3.90	0	20	7	0	140	FKM	221G6506	4538	486265	-	-	-	14	14	2.0	3732	
15		65	3.90	0	16	-	0	80	FKM	221G6506	-	495905	-	1-21	Ex db mb IIC T4	8	-	2.0	3732	
15		65	3.90	0	-	10	-10	100	FKM	221G6536	2995	481865	-	-	-	-	9	2.1	3732	
15		65	3.90	0	-	10	-10	65	FKM	221G6536	2995	495870	-	2-22	Ex nAc nCc IIC T3/T4	-	9	2.1	3732	
15		65	3.90	0	10	10	-10	65	FKM	221G6536	-	492070	-	1-21	Ex mb IIC T4/T5	9	8	2.1	3732	
15		65	3.90	0	10	10	-10	75	FKM	221G6536	-	492190	-	1-21	Ex eb mb IIC T3/T4	11	9	2.1	3732	
15		65	3.90	0	-	10	-10	80	FKM	221G6536	-	495905	-	1-21	Ex db mb IIC T4	-	8	2.1	3732	

Notes:

1. With silver shading ring
2. For air, the ambient temperature is limited to +25°C, and the max fluid temperature to +40°C
The maximum fluid temperature is given for the lower coil class temperature. See coil pages for more details.

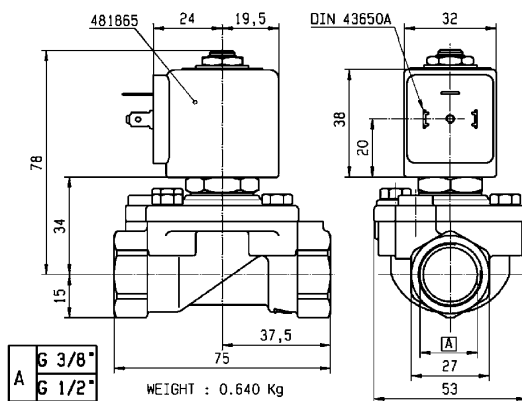

Drawing 3732



2/2

221G Series

Valves for dry or lubricated air, neutral gases and liquids
Magnalift - Port size from 3/4" to 1" and orifice from 15.0mm to 25mm



316L Stainless St.

Pipe Mounting

Normally Closed

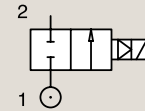

Port Size	Orifice Ø mm	Flow Factors		Operating Pressure Differential			Fluid Temperature		Seat Seal	Parker Valves			IS	ATEX Zone	Protection Mode	Power		Coil Group	Dwg N°
		Kv l/min	KV m³/h	Min. Bar	Max. (MOPD) AC bar	DC bar	Min. °C	Max. °C		Valve Ref.	Housing Ref.	Coil Ref.				AC W	DC W		
3/4"	15	80	4.80	0	16	-	0	100	FKM	221G6606 ₁	2995	481865	-	-	-	8	-	2.0	8451
	15	80	4.80	0	-	6	0	60	FKM	221G6606 ₁₂	2995	492425	-	-	-	-	14	2.0	8451
	15	80	4.80	0	16	-	0	65	FKM	221G6606 ₁	2995	495870	-	2-22	Ex nAc nCc IIC T3/T4	8	-	2.0	8451
	15	80	4.80	0	16	-	0	120	FKM	221G6606 ₁	4538	481000	-	-	-	8	-	2.0	8451
	15	80	4.80	0	20	7	0	140	FKM	221G6606 ₁	4538	486265	-	-	-	14	14	2.0	8451
	15	80	4.80	0	16	-	0	80	FKM	221G6606 ₁	-	495905	-	1-21	Ex db mb IIC T4	8	-	2.0	8451
	15	80	4.80	0	-	10	-10	100	FKM	221G6636	2995	481865	-	-	-	-	9	2.1	8451
	15	80	4.80	0	-	10	-10	65	FKM	221G6636	2995	495870	-	2-22	Ex nAc nCc IIC T3/T4	-	9	2.1	8451
	15	80	4.80	0	10	10	-10	65	FKM	221G6636	-	492070	-	1-21	Ex mb IIC T4/T5	9	8	2.1	8451
	15	80	4.80	0	10	10	-10	75	FKM	221G6636	-	492190	-	1-21	Ex eb mb IIC T3/T4	11	9	2.1	8451
1"	15	80	4.80	0	-	10	-10	80	FKM	221G6636	-	495905	-	1-21	Ex db mb IIC T4	-	8	2.1	8451
	25	160	9.60	0	16	-	0	100	FKM	221G6106 ₁	2995	481865	-	-	-	8	-	2.0	3448
	25	160	9.60	0	-	6	0	60	FKM	221G6106 ₁₂	2995	492425	-	-	-	-	14	2.0	3448
	25	160	9.60	0	16	-	0	65	FKM	221G6106 ₁	2995	495870	-	2-22	Ex nAc nCc IIC T3/T4	8	-	2.0	3448
	25	160	9.60	0	16	6	0	120	FKM	221G6106 ₁	4538	486265	-	-	-	14	14	2.0	3448
	25	160	9.60	0	16	-	0	80	FKM	221G6106 ₁	-	495905	-	1-21	Ex db mb IIC T4	8	-	2.0	3448
	25	170	10.20	0	-	10	-10	100	FKM	221G6136	2995	481865	-	-	-	-	9	2.0	3448
	25	170	10.20	0	-	10	-10	65	FKM	221G6136	2995	495870	-	2-22	Ex nAc nCc IIC T3/T4	-	9	2.0	3448
	25	170	10.20	0	-	10	-10	100	FKM	221G6136	4538	481000	-	-	-	-	8	2.0	3448
	25	170	10.20	0	-	10	-10	80	FKM	221G6136	-	495905	-	1-21	Ex db mb IIC T4	-	8	2.0	3448

Notes:

1. With silver shading ring
2. For air, the ambient temperature is limited to +25°C, and the max fluid temperature to +40°C
The maximum fluid temperature is given for the lower coil class temperature. See coil pages for more details.



Drawing 8451



Drawing 3448

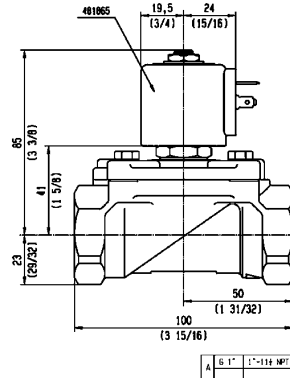
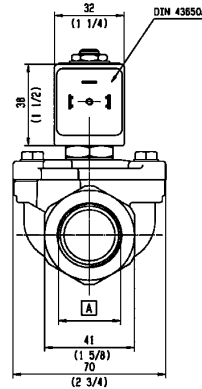
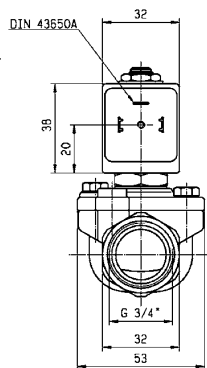
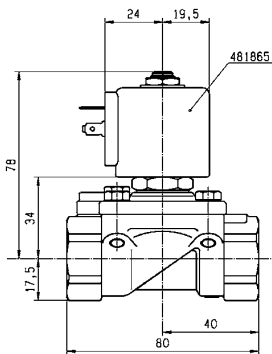

Liquipure® Series

Product Description

Parker Liquipure® Valve Series is the ultimate solution developed by Parker, marking a new standard for Beverage Dispensing and Life Sciences appliances.

For this new valve concept we have selected lead free materials in compliance with the most restrictive standards and regulations, in accordance with Market and People expectations concerning health.

A wide range of Liquipure® valves is also NSF certified. The innovative design makes the product easy to maintain. Liquipure® is interchangeable with 32 x 32 sub base mounting solutions.

Product is available in 2/2 and 3/2 configuration, normally closed. It is also available in 3/2 Universal function making the valve applicable as diverter or selector.

An adapter kit is also offered to convert the product into a pipe mounting version. A wide range of seals is also available, including FKM-FDA, Ruby and EPDM in order to optimize compatibility with the media.

Liquipure® technology is unique, protected by patent and is a registered trademark of Parker Hannifin Corporation.



Applications

Typical applications:

- Coffee Machines, professional, semi-professional and vending
- Water purification and water preparation
- Food & Beverage processing, Healthy Beverage Dispense equipment
- Demineralized water shut off
- Dishwasher disinfectors, hot steam sterilizers

Market of interest:

- Coffee machine
- Beverage dispensing

Benefits

- Healthy and foodstuffs compatible
- Full stainless steel structure
- Wide range of Liquipure® valves is NSF certified
- Increase of reliability: reduction of welding joints
- Easy to maintain: easy and quick access to internal parts for cleaning and service

General Description

Materials in contact with the fluid:

Valve body and seat support: AISI 305 Stainless Steel

Seat: AISI 303 Stainless Steel

Plungers: AISI 430F Stainless Steel

Springs: AISI 302 Stainless Steel

Tube assembly : Stainless Steel

Main seat disc: FKM-FDA, Ruby, EPDM

Exhaust seat disc (static sealing): FKM-FDA

Adapter: AISI 304 Stainless Steel

Media

These valves have been developed to achieve a wide range of chemical compatibilities

Temperature

The ambient temperature range of the valve is -10°C to +50°C.



Installation

Valves can be mounted in any position, respecting the installation scheme. Valves have been developed to achieve the best performances with water, superheated water and steam.

Maximum recommended media temperature is 140°C.

Parker wide variety of coils including IP65 & IP67 with UL & IEC/CE-NELEC & Dual Frequency.

Each valve must be mounted using 4 screws M4 x 0,7, minimum recommended length: 6.0 mm. It is mandatory to install the valve using 4 screws, for a proper use of it.

Mounting : Sub-base features (SB)

For Valves with orifice $\varnothing < 3 \text{ mm}$

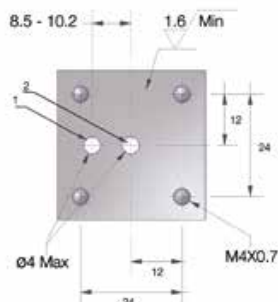

For Valves with orifice $\varnothing > 4.0 \text{ mm to } 5 \text{ mm max}$

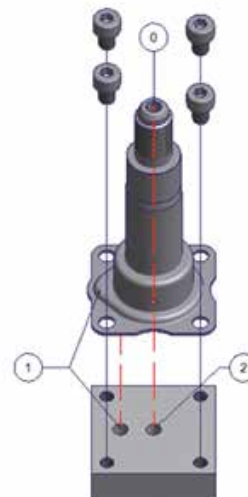
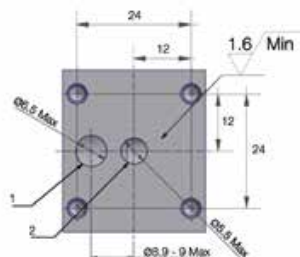

Easy Maintenance

Among the most innovative features of Liquipure® Valve Series you will find an easy and quick access to internal parts, without any specific tools.

The image on the right show how the seat support can be mounted and dismantled to get a quick access to the valve plunger in order to clean it or replace it after a long operating life.

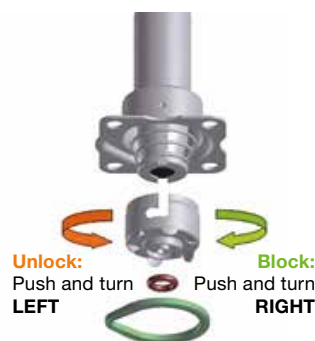

How to Order

Step 1: Select the valve body reference needed

Step 2: Select the coil and the voltage code in coil pages starting from page 45

Step 3: Define the complete assembly numbering system

Step 4: accessories

Din Plug Connector according to DIN EN 175301-803 Form A **600003PLUG** (batch size = 100)

You can now identify the complete Liquipure® designation which must be used to release your order !

Please note: Valve can be ordered according to desired configuration: Valve body and coil separately, Valve body and coil assembled or Valve body, pipe mounting adaptation kit and coil assembled (pipe mounting version)

2/2

Liquipure® Series

Valves for beverage dispensing

Direct Operated - Sub-base and orifice from 1.5mm to 5.0mm



305 Stainless St.

Sub-base Mounting

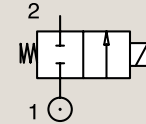

Normally Closed

Port Size	Orifice Ø	Flow Factors		Operating Pressure Differential			Fluid Temperature		Seat Seal	Parker Valves		Power		Coil Group	Adapter Kit
		Kv	KV	Min. Bar	Max. (MOPD) AC bar	DC bar	Min. °C	Max. °C		Valve Ref.	Coil Ref.	AC W	DC W		
BSP	1.5	1.3	0.08	0	20	20	-10	140	Ruby	2019F1GRG7 ₁	D5	8	9	24.0	XGSPG1-XGSPG2
	1.5	1.3	0.08	0	20	20	-10	140	FDA FKM	2019F1GVG7 ₁	D5	8	9	24.0	XGSPG1-XGSPG2
	2.0	2.3	0.14	0	15	15	-10	140	Ruby	2019F1JRG7 ₁	D5	8	9	24.0	XGSPG1-XGSPG2
	2.0	2.3	0.14	0	15	15	-10	140	FDA FKM	2019F1JVG7 ₁	D5	8	9	24.0	XGSPG1-XGSPG2
	2.5	3.2	0.19	0	10	10	-10	140	Ruby	2019F1LRG7 ₁	D5	8	9	24.0	XGSPG1-XGSPG2
SB	2.5	3.2	0.19	0	10	10	-10	140	FDA FKM	2019F1LVG7 ₁	D5	8	9	24.0	XGSPG1-XGSPG2
	3.0	4.2	0.25	0	7	7	-10	140	Ruby	2019F1NRG7 ₁	D5	8	9	24.0	XGSPG1-XGSPG2
	3.0	4.2	0.25	0	7	7	-10	140	FDA FKM	2019F1NVG7 ₁	D5	8	9	24.0	XGSPG1-XGSPG2
	4.0	6.5	0.39	0	5	5	-10	140	EPDM	2019F1QEG7 ₁	D5	8	9	24.0	XGSPG3
	4.0	6.5	0.39	0	5	5	-10	140	FDA FKM	2019F1QVG7 ₁	D5	8	9	24.0	XGSPG3
	5.0	7.2	0.43	0	3	3	-10	140	EPDM	2019F1SEG7 ₁	D5	8	9	24.0	XGSPG3
	5.0	7.2	0.43	0	3	3	-10	140	FDA FKM	2019F1SVG7 ₁	D5	8	9	24.0	XGSPG3

Notes:

- 1. NSF Certified
- Nominal Pressure = 20 bar

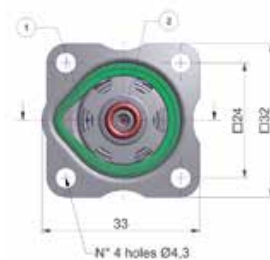
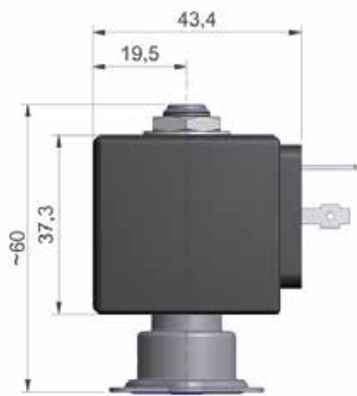

All dimensions are in mm



3/2

Liquipure® Series

Valves for beverage dispensing Hose Bib at Exhaust Port
Direct Operated - Sub-base and orifice from 1.5mm to 5.0mm

SIL NSF

305 Stainless St.

Sub-base Mounting

Normally Closed

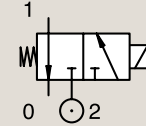

Port Size	Orifice mm		Flow Factors				Operating Pressure Differential			Fluid Temperature		Seat Seal	Parker Valves		Power		Coil Group	Adapter Kit
	1	(2)	Kv	KV	Kv	KV	Min. Bar	Max. (MOPD) AC bar	DC bar	Min. °C	Max. °C		Valve Ref.	Coil Ref.	AC W	DC W		
SB	1.5	2.5	1.3	0.08	2.9	0.17	0	14	14	-10	140	Ruby	301XGFRTG7 ₁	D5	8	9	24.0	XGSPG1-XGSPG2
	1.5	2.5	1.3	0.08	2.9	0.17	0	14	14	-10	140	FDA FKM	301XGFVTG7 ₁	D5	8	9	24.0	XGSPG1-XGSPG2
	2.0	2.5	2.2	0.13	2.9	0.17	0	10	10	-10	140	Ruby	301XGFRTJ7 ₁	D5	8	9	24.0	XGSPG1-XGSPG2
	2.0	2.5	2.2	0.13	2.9	0.17	0	10	10	-10	140	FDA FKM	301XGFVTJ7 ₁	D5	8	9	24.0	XGSPG1-XGSPG2
	2.5	2.5	2.8	0.17	2.9	0.17	0	6.5	6.5	-10	140	Ruby	301XGFRTL7 ₁	D5	8	9	24.0	XGSPG1-XGSPG2
	2.5	2.5	2.8	0.17	2.9	0.17	0	6.5	6.5	-10	140	FDA FKM	301XGFVTL7 ₁	D5	8	9	24.0	XGSPG1-XGSPG2
	3.0	2.5	4.2	0.25	2.9	0.17	0	4	4	-10	140	Ruby	301XGFRTN7 ₁	D5	8	9	24.0	XGSPG1-XGSPG2
	3.0	2.5	4.2	0.25	2.9	0.17	0	4	4	-10	140	FDA FKM	301XGFVTN7 ₁	D5	8	9	24.0	XGSPG1-XGSPG2
	4.0	2.5	6.5	0.39	2.9	0.17	0	3	3	-10	140	EPDM	301XGFETQ7	D5	8	9	24.0	XGSPG3
	4.0	2.5	6.5	0.39	2.9	0.17	0	3	3	-10	140	FDA FKM	301XGFVTQ7 ₁	D5	8	9	24.0	XGSPG3
	5.0	2.5	7.2	0.43	2.9	0.17	0	2	2	-10	140	EPDM	301XGFETS7	D5	8	9	24.0	XGSPG3
	5.0	2.5	7.2	0.43	2.9	0.17	0	2	2	-10	140	FDA FKM	301XGFVTS7 ₁	D5	8	9	24.0	XGSPG3

Notes:

1. NSF Certified
Nominal Pressure = 20 bar

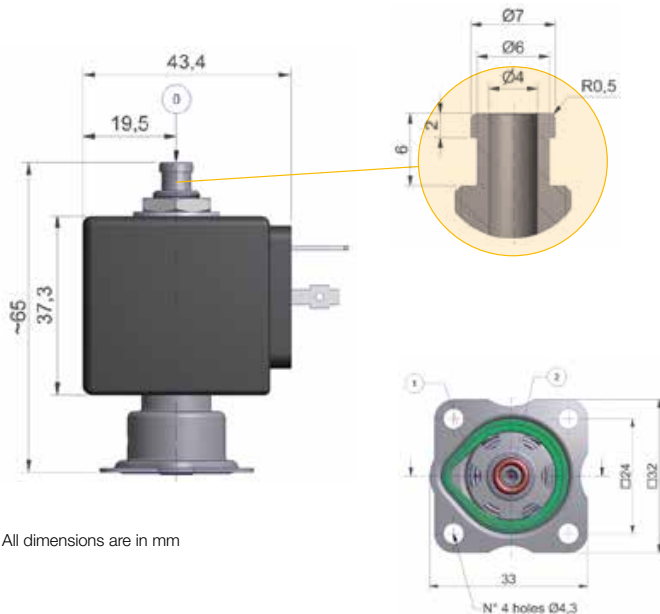

All dimensions are in mm



3/2

Liquipure® Series

Valves for beverage dispensing 1/8" G threaded Male Exhaust Port
Direct Operated - Sub-base and orifice from 1.5mm to 3.0mm

SIL

305 Stainless St.

Sub-base Mounting

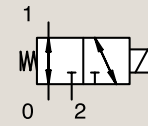

Universal

Port Size	Orifice mm		Flow Factors				Operating Pressure Differential			Fluid Temperature		Seat Seal	Parker Valves		Power		Coil Group	Adapter Kit
	1	(2)	Kv l/min	KV m³/h	Kv l/min	KV m³/h	Min. Bar	Max. (MOPD) AC bar	DC bar	Min. °C	Max. °C		Valve Ref.	Coil Ref.	AC W	DC W		
SB	1.5	1.5	1.4	0.08	1.3	0.08	0	9.5	9.5	-10	140	EPDM	3039F1GEG7	D5	8	9	24.0	XGSPG1-XGSPG2
	1.5	1.5	1.4	0.08	1.3	0.08	0	9.5	9.5	-10	140	FDA FKM	3039F1GVG7 ₁	D5	8	9	24.0	XGSPG1-XGSPG2
	2.0	2.0	2.1	0.13	2	0.12	0	3.5	3.5	-10	140	EPDM	3039F1JEG7	D5	8	9	24.0	XGSPG1-XGSPG2
	2.0	2.0	2.1	0.13	2	0.12	0	3.5	3.5	-10	140	FDA FKM	3039F1JVG7 ₁	D5	8	9	24.0	XGSPG1-XGSPG2
	2.5	2.5	2.8	0.17	2.8	0.17	0	2	2	-10	140	EPDM	3039F1LEG7	D5	8	9	24.0	XGSPG1-XGSPG2
	2.5	2.5	2.8	0.17	2.8	0.17	0	2	2	-10	140	FDA FKM	3039F1LVG7 ₁	D5	8	9	24.0	XGSPG1-XGSPG2
	3.0	2.5	3.3	0.20	2.8	0.17	0	2	2	-10	140	EPDM	3039F1NEG7	D5	8	9	24.0	XGSPG1-XGSPG2
	3.0	2.5	3.3	0.20	2.8	0.17	0	2	2	-10	140	FDA FKM	3039F1NVG7 ₁	D5	8	9	24.0	XGSPG1-XGSPG2

Notes:

1. NSF Certified
Nominal Pressure = 20 bar

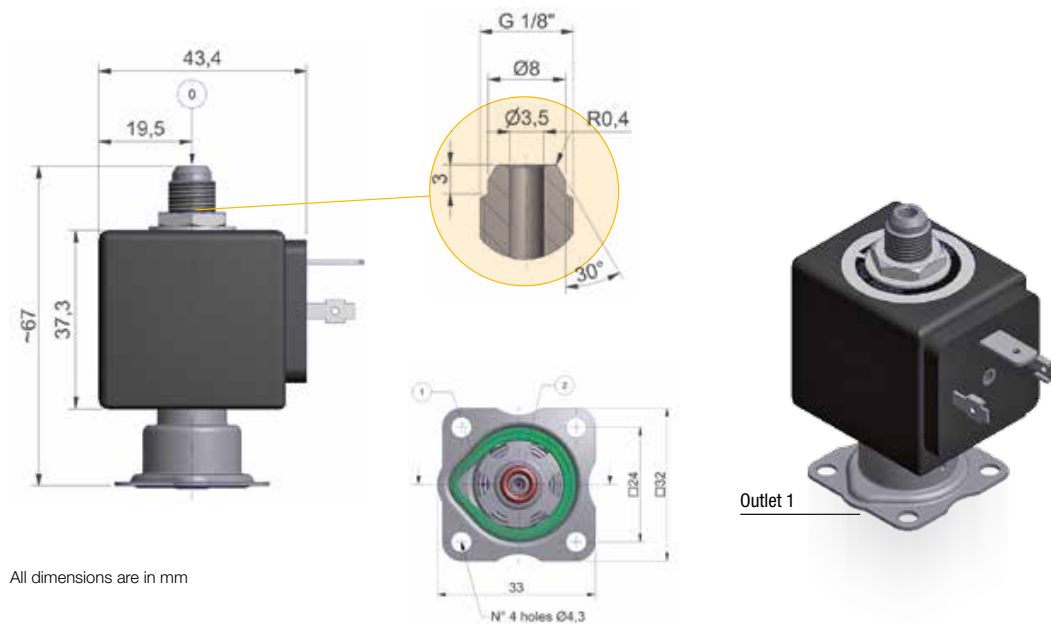

All dimensions are in mm



Liquipure® Adapter

Easy mounting for all applications

Adapter kits are available for all Liquipure® Valves in 1/8" or 1/4"G.

Port Size	Part Number	Material	Kit Including	Compatible with Valves with
1/8"G	XGSPG1	AISI 304	fixing screws	any < 3.0 mm orifice
1/4"G	XGSPG2	AISI 304	fixing screws	any < 3.0 mm orifice
1/4"G	XGSPG3	AISI 304	fixing screws	4.0 mm to 5 mm orifice

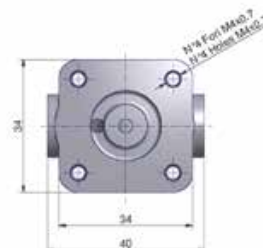
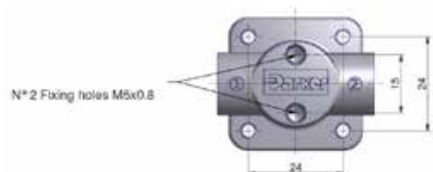

All dimensions are in mm

Spare Parts

Plunger Service Kit

Plunger Type	Main Seat Seals	Part Number	To be used with	Box Quantity
2 Ways	FKM FDA	7GRP01	2019F1 FKM FDA Seals version	50
3 Ways	FKM FDA	7GRP02	3019F1-301XG FKM FDA Seals version	50
2 Ways	Ruby	7GRP03	2019F1 Ruby Seals version	50
3 Ways	Ruby	7GRP04	3019F1-301XG Ruby Seals version	50
2 Ways	FKM FDA	7GRP05	2019F1QVG7 FKM FDA Seals version	50
3 Ways	FKM FDA	7GRP06	3019F1QVG7-301XGFVTQ7 FKM FDA Seals version	50
2 Ways	EPDM	7GRP07	2019F1SVG7 EPDM Seals version	50
3 Ways	EPDM	7GRP08	3019F1SVG7-301XG EPDM Seals version	50

Note: contains plunger only

Flange Interface Seals

Seals Type	Seals Material	Part Number	To be used with	Box Quantity
Flange Interface Seals	FKM FDA	7GRS01	any version	50



501C Series

Product Description

The new 501C Stainless Steel is the right answer to complete on healthy valve range for professional coffee machine, water dispenser and vending machines.

For this new valve, we have selected lead free materials in compliance with the most restrictive standards and regulations, in accordance with market and people expectations concerning health.

Fully made of Stainless Steel, with FKM FDA robust seals, in order to give you the best Foodstuff Compatibility. This new stainless steel product family is NSF certified.

Thanks to the modular concept, a wide range of electrical parts can be used, including F Class, IP67, H Class, reduced power and UL/VDE approved.



Applications

Market of interest:

- Life Sciences
- Food & Beverage Processing
- Commercial Equipment
- Industrial equipment
- Waste Water treatment

Typical applications:

- Water purification and preparation devices
- Food & Beverage processing, Healthy Beverage Dispense equipment
- Demineralized water shut off, cooling of medical and surgical devices
- Dishwasher disinfectors, Laboratory and high end hot steam sterilizers
- Aggressive liquids shut-off

Benefits

The most valuable features you will find in this product range:

- High grade corrosion resistant valve body
- NSF certified references available
- FFKM seal option for superior endurance in heavy duty conditions
- Modular concept: a wide range of electrical parts can be used with this family, including ATEX, low power, IP67, UL/VDE approved
- Robust and solid design

These valves have been developed to achieve a wide range of chemical compatibilities

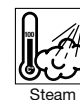

General Description

Materials in contact with the fluid

Valve Body:

AISI 303 Stainless Steel

Seat:

AISI 303 Stainless Steel

Plungers:

AISI 430F Stainless Steel

Springs:

AISI 302 Stainless Steel

Main Seat disc:

FKM, FFKM

Shading ring:

Copper

Tube assembly:

AISI 303 Stainless Steel

AISI 305 Stainless Steel

Installation

The valves can be mounted in any position. It is however recommended to install them with the coil in vertical position above the body.

Media

These valves have been developed to achieve the best performances with a wide range of media.

Temperature

The ambient temperature range of the valve is -10°C to +50°C.

Coils

A wide range of coils can be used with this range.

The complete coil range is described in pages 45 to 69.



How to Order

Step 1: Select the valve body reference needed from page 31 **Example: 501CG1GVG7**

Step 2: Select the coil and the voltage code in coil pages starting from page 45. **Example: D5B Series**

Step 3: You can now identify the complete 501C designation which must be used to release your order!
Example: 501CGV7D5B.

Step 4: Accessories

Din Plug Connector according to DIN EN 175301-803 Form A **600003PLUG** (batch size = 100)

Please note: Valve can be ordered according to desired configuration: Valve body and coil separately, Valve body and coil assembled or Valve body, pipe mounting adaptation kit and coil assembled (pipe mounting version)

2/2

501C Series

Valves for beverage dispensing

Direct Operated - Port size from 1/8" to 1/4" and orifice from 1.5mm to 2.5mm



303 Stainless St.

Pipe Mounting

Normally Closed

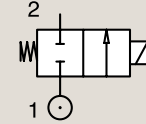

Port Size	Orifice Ø mm	Flow Factors		Operating Pressure Differential			Fluid Temperature		Seat Seal	Parker Valves		Power		Coil Group
		Kv l/min	KV m³/h	Min. Bar	Max. (MOPD) AC bar	DC bar	Min. °C	Max. °C		Valve Ref.	Coil Ref.	AC W	DC W	
1/8"	1.5	1.1	0.06	0	14	14	-10	140	FDA FKM	501CG1GVG7	D5	8	9	24.0
	2.5	2.5	0.15	0	12	12	-10	140	FDA FKM	501CG1LVG7	D5	8	9	24.0
1/4"	1.5	1.1	0.06	0	14	14	-10	140	FDA FKM	501CG2GVG7	D5	8	9	24.0
	2.5	2.5	0.15	0	12	12	-10	140	FDA FKM	501CG2LVG7	D5	8	9	24.0

Notes:
All the references listed in this chart are NSF certified.

Dimensional References:

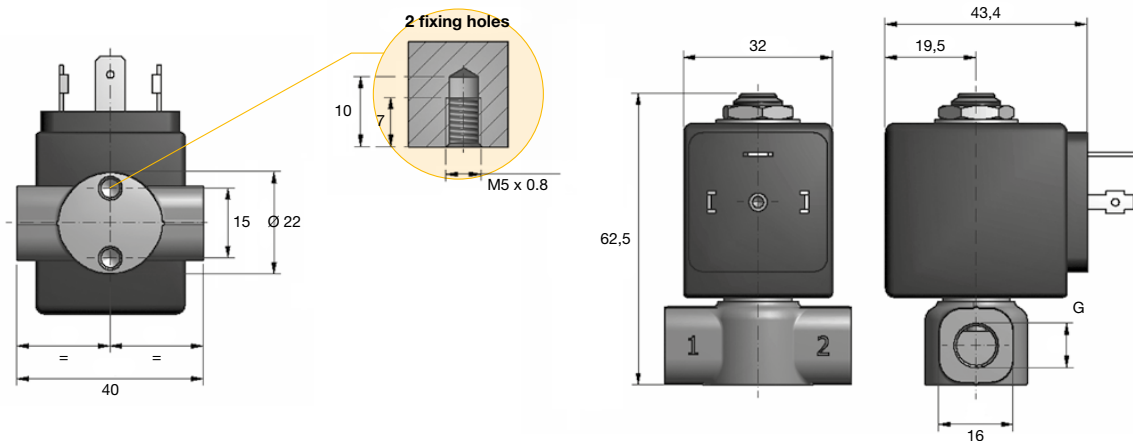

Electrical Parts Availability:

Product line is compatible with a wide range of coils including Mono and Double Frequency solutions, 2P+E connection according with DIN EN 175301-803, Form A and flying leads versions.

X Series

Product Description

Universal 3 ways valves 1/4" NPTF with 316L material body for ATEX zones from zone 0 to zone 2 or with standard coils for non ATEX applications.

Available with manual reset.



Applications

Market of interest:

- Process
- Oil & Gas

Typical applications:

- Valve actuation control

Benefits

The most valuable features you will find in this product range:

- High grade corrosion resistant valve body, AISI 316L
- Modular concept: a wide range of electrical parts can be used with this family, including ATEX, low power, IP67, UL/VDE approved
- Robust and solid design
- Compact coils
- Easy maintenance
- Quick coil removal



General Description

Material Specifications

Valve Body:

AISI 316L Stainless Steel

Seals:

NBR

Installation

The valves can be mounted in any position. It is however recommended to install them with the coil in vertical position above the body.

Media

These valves have been developed to achieve the best performances with air & neutral gas

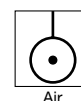

Temperature

The ambient temperature range of the valve is -25°C to +65°C.

For ATEX environments: temperature can be limited by the max ambient temperature of the coil. See coil pages.



Coils

A wide range of coils can be used with this range.

The complete coil range is described in pages 45 to 69.

How to Order

A complete solenoid valve is composed by 2 elements: the **valve body** and the **coil**.

Step 1: Select the valve body reference needed **Example: U033X7156**

Step 2: Select the coil ref. + voltage code.

Find the voltage code in coil pages starting from page 45 **Example: 496565N7**

Step 5: The complete assembly numbering system is : **Example U033X7156-496565N7**

Step 4: accessories

Din Plug Connector according to DIN EN 175301-803 Form A **48658640** (batch size = 25)

You can now identify the complete Ux33X designation which must be used to release your order !

Please note: Valve can be ordered according to desired configuration: Valve body and coil separately, Valve body and coil assembled

3/2

Ux33X Series

3 & 5 way valves for actuator control

Direct Operated - Port size 1/4" and orifice 6.0mm



316L Stainless St.

Pipe Mounting

Universal

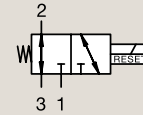

Port Size	Orifice Ø mm	Flow Factors		Operating Pressure Differential			Fluid Temperature		Seat Seal	Parker Valves			IS ATEX Zone	Protection Mode	Power		Coil Group	Dwg N°	
		Kv	m³/h	Min. Bar	Max. AC bar	Max. DC bar	Min. °C	Max. °C		Valve Ref.	Housing Ref.	Coil Ref.			AC W	DC W			
1/4"	6.0	9.0	0.54	0	-	12	-25	65	NBR	U033X7156 ₂	-	496565	√	0-20	Ex ia IIC T4 to T6	-	0.8-2.6	9.0/10.1/10.2	8168
	6.0	9.0	0.54	0	12	12	-25	65	NBR	U033X7156 ₂	-	496700	-	1-21	Ex db mb IIC T4 to T6	6	6	9.0/10.1/10.2	8168
	6.0	9.0	0.54	0	12	12	-25	65	NBR	U033X7156 ₂	-	496895	-	-	-	8	8	9.0/10.1/10.2	8168
	6.0	9.0	0.54	0	12	12	-25	65	NBR	U033X7156 ₂	-	497105	√	1-21	Ex db IIC T4 to T6	8	8	9.0/10.1/10.2	8308
	6.0	9.0	0.54	0	-	12	-25	65	NBR	U133X7156 ₁	-	496565	√	0-20	Ex ia IIC T4 to T6	-	0.8-2.6	9.0/10.1/10.2	8168
	6.0	9.0	0.54	0	12	12	-25	65	NBR	U133X7156 ₁	-	496700	-	1-21	Ex db mb IIC T4 to T6	6	6	9.0/10.1/10.2	8168
	6.0	9.0	0.54	0	12	12	-25	65	NBR	U133X7156 ₁	-	496895	-	-	-	8	8	9.0/10.1/10.2	8168
	6.0	9.0	0.54	0	12	12	-25	65	NBR	U133X7156 ₁	-	497105	√	1-21	Ex db IIC T4 to T6	8	8	9.0/10.1/10.2	8308
	6.0	9.0	0.54	0	-	12	-25	65	NBR	U133X7196	-	496565	√	0-20	Ex ia IIC T4 to T6	-	0.8-2.6	9.0/10.1/10.2	8314
	6.0	9.0	0.54	0	12	12	-25	65	NBR	U133X7196	-	496700	-	1-21	Ex db mb IIC T4 to T6	6	6	9.0/10.1/10.2	8314
	6.0	9.0	0.54	0	12	12	-25	65	NBR	U133X7196	-	496895	-	-	-	8	8	9.0/10.1/10.2	8314
	6.0	9.0	0.54	0	12	12	-25	65	NBR	U133X7196	-	497105	√	1-21	Ex db IIC T4 to T6	8	8	9.0/10.1/10.2	8314

Notes:

1. With manual override
2. With manual reset

The maximum fluid temperature is given for the lower coil class temperature. See coil pages for more details.

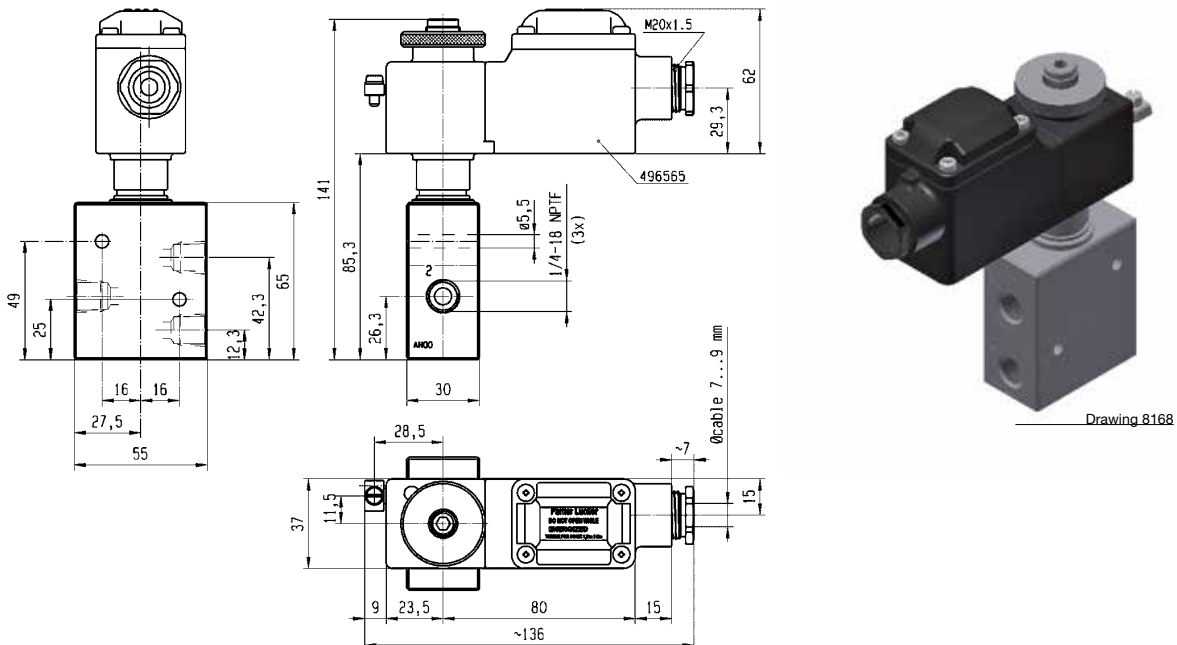

Drawing 8168



Angle Seat Valves PA Series

Product Description

An angle seat valve is actuated by a pneumatically driven piston and is capable to handle slurry solutions with particles or corrosive solutions at high temperature up to 180°C and operating pressure up to 16 Bar.



Applications

Market of interest:

- Life Sciences
- Food & Beverage Processing
- Industrial Equipment
- Commercial Equipment
- Waste Water treatment
- Textile industry

Typical applications:

- Sterilizers steam supply
- Dishwasher disinfectors, Laboratory and high end hot steam sterilizers
- Pharmaceutical, Chemical & Cosmetic industry

Benefits

The most valuable features you will find in this product range:

- **Compact** design, high flow rates
- Visual **position indicator**
- For temperatures from -10°C to **180°C**
- Working pressures up to **16 Bar**
- Fluid **Viscosity up to 600 mm²/s** (600cSt, 80° E, 2700 SSU)
- Dampened closing **anti-water hammer** design (fluid under seat)
- Stainless Steel actuator housing for exceptional durability in **steam and aggressive applications**
- Valves meeting Pressure Equipment Directive 97/23/EC
- Mountable **in any position**
- Tight shut-off and Long Service Life
- Parker Angle Seat Valves conform to the terms of the 94/9/CE directive specific to non electrical equipment for use within potentially explosive environments - **zones 1/21 and 2/22**



General Description

Material Specifications

Valve Body:

ANSI 316L Stainless Steel

Seals:

PTFE/RTFE

Nozzle:

ANSI 316L Stainless Steel

Sealings:

PTFE/RTFE for seat seal material

PTFE with carbon for packing gland (EPDM for 100°C versions)

Temperature

The ambient temperature range of the valve is -10°C to +60°C.

For ATEX environments: temperature can be limited by the max ambient temperature of the coil.

See coil pages.

Please note that for liquids use the versions with flow direction under the seat to avoid water hammer effect

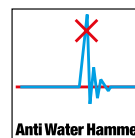

Accessories :

- 3 Way Direct Acting AC & DC Pilot Control Valves available as separate components

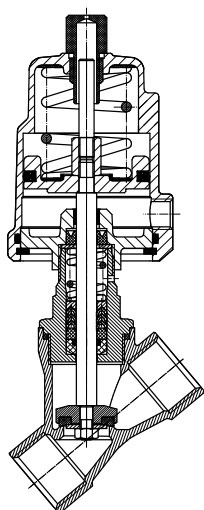

Normally Closed Valve

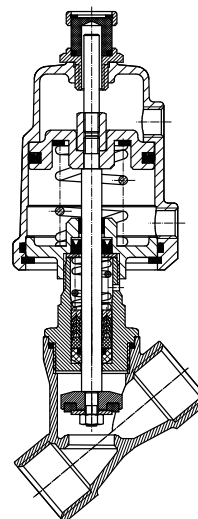

Normally Open Valve

How to Order

Select the complete valve in the tables in next pages

EXAMPLE: PA10C1G3R032S



2/2

PA Series Flow Direction Over Seat

Air Operated - Port size from 3/8" to 2-1/2" and orifice from 13.0mm to 65.0mm



316L S.Steel Body / 304 S.Steel Actuator

Pipe Mounting

Normally Closed

Size	Port Size BSP	Orifice Ø mm	Actuator mm	KV m³/h	Operating Pressure Differential bar	Minimum Pilot Control Pressure Range bar	Fluid Temperature		Parker Valves
							Min. C°	Max. C°	Valve Reference
DN10	3/8"	13	32	4.7	0-16	4.5-6	-10	180	PA10C1G3R032S
		13	32	4.7	0-16	4.5-6	-10	100	PA10C3G3R032S
		13	40	4.7	0-16	4	-10	180	PA10S1G3R040S
		13	50	4.7	0-16	3	-10	180	PA10S1G3R050S
DN15	1/2"	13	32	4.7	0-16	4.5-6	-10	180	PA15C1G4R032S
		13	32	4.7	0-16	4.5-6	-10	100	PA15C3G4R032S
		13	40	4.7	0-16	4	-10	180	PA15S1G4R040S
		13	50	4.7	0-16	3	-10	180	PA15S1G4R050S
DN20	3/4"	15	32	5.4	0-14	4.5-6	-10	180	PA20C1G5R032S
		15	32	5.4	0-14	4.5-6	-10	100	PA20C3G5R032S
		18	50	9.0	0-16	3-4	-10	180	PA20S1G5R050S
DN25	1"	24	50	16.0	0-16	3-5.5	-10	180	PA25S1G6R050S
		24	63	16.0	0-16	3-3.5	-10	180	PA25S1G6R063S
DN32	1-1/4"	31	63	24.0	0-16	3-5	-10	180	PA32S1G7R063S
DN40	1-1/2"	35	63	32.0	0-16	3-6	-10	180	PA40S1G8R063S
		45	63	50.0	0-10	3-6.5	-10	180	PA50S1G9R063S
DN50	2"	45	80	50.0	0-16	3-6.6	-10	180	PA50S1G9R080S
		45	100	50.0	0-16	3-5	-10	180	PA50S1G9R100S
DN65	2-1/2"	65	100	70.0	0-10	3-6	-10	180	PA65S1GTR100S

316L S.Steel Body / Aluminium Actuator

Pipe Mounting

Normally Closed

Size	Port Size	Orifice Ø mm	Actuator mm	KV m³/h	Operating Pressure Differential bar	Minimum Pilot Control Pressure Range bar	Fluid Temperature		Parker Valves
							Min. C°	Max. C°	Valve Reference
DN10	3/8"	13	50	4.7	0-16	3	-10	180	PA10S1G3R050A
DN15	1/2"	13	50	4.7	0-16	3	-10	180	PA15S1G4R050A
DN20	3/4"	18	50	9.0	0-16	3-4	-10	180	PA20S1G5R050A
DN25	1"	24	50	16.0	0-16	3-5.5	-10	180	PA25S1G6R050A
		24	63	16.0	0-16	3-4	-10	180	PA25S1G6R063A
DN32	1-1/4"	31	63	24.0	0-16	3-5.5	-10	180	PA32S1G7R063A
DN40	1-1/2"	35	63	32.0	0-16	3-6.5	-10	180	PA40S1G8R063A
		45	63	50.0	0-10	3-6.5	-10	180	PA50S1G9R063A
DN50	2"	45	80	50.0	0-16	3-6.6	-10	180	PA50S1G9R080A
		45	100	50.0	0-16	3-5	-10	180	PA50S1G9R100A
DN65	2-1/2"	65	100	70.0	0-10	3-6	-10	180	PA65S1GTR100A



PA Series

Flow Direction Over Seat

Air Operated - Port size from 3/8" to 2-1/2" and orifice from 13.0mm to 65.0mm



Control & Operating Pressure Charts for the normally Closed Valves with flow over seat

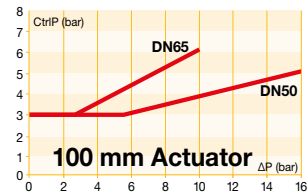
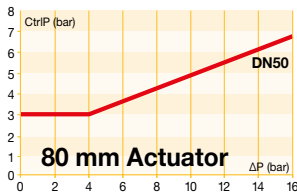
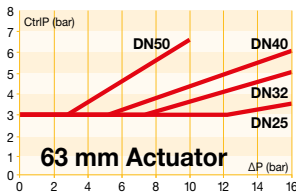
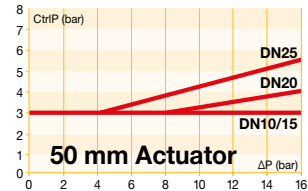
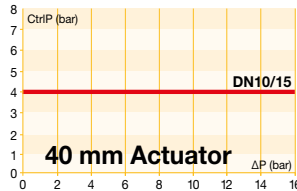
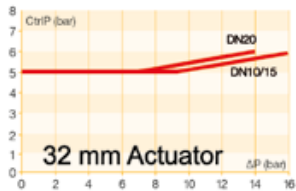

Flow Diagram Over Seat

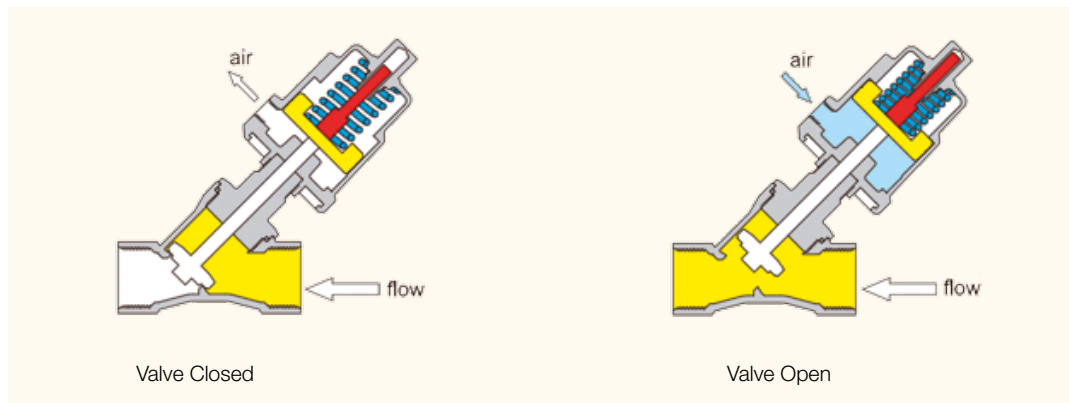

2/2

PA Series

Flow Direction Over Seat

Air Operated - Port size from 3/8" to 2" and orifice from 13.0mm to 45.0mm



316L S.Steel Body / 304 S.Steel Actuator

Pipe Mounting

Normally Open

Size	Port Size	Orifice Ø mm	Actuator mm	KV m ³ /h	Operating Pressure Differential bar	Minimum Pilot Control Pressure Range bar	Fluid Temperature		Parker Valves
							Min. C°	Max. C°	Valve Reference
DN10	3/8"	13	50	4.7	0-16	3.5	-10	180	PA10S2G3R050S
DN15	1/2"	13	50	4.7	0-16	3.5	-10	180	PA15S2G4R050S
DN20	3/4"	18	50	9.0	0-16	3.5	-10	180	PA20S2G5R050S
DN25	1"	24	63	16.0	0-16	4.5	-10	180	PA25S2G6R063S
DN32	1-1/4"	31	63	24.0	0-14	4.5	-10	180	PA32S2G7R063S
DN40	1-1/2"	35	63	32.0	0-11	4.5	-10	180	PA40S2G8R063S
DN50	2"	45	63	50.0	0-6	5	-10	180	PA50S2G9R063S
		45	80	50.0	0-12	5	-10	180	PA50S2G9R080S

Control & Operating Pressure

Please note : Charts do not apply for Normally Open Valves. A minimum pressure as noted above is all that is required, up to 10 bar Maximum.

Flow Diagram Over Seat

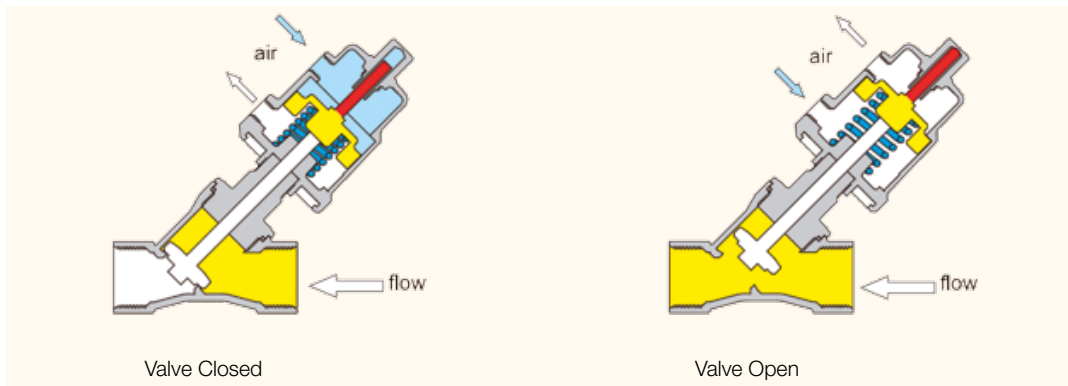

2/2

PA Series

Flow Direction Under Seat with Anti Water Hammer Construction
Air Operated - Port size from 3/8" to 2" and orifice from 13.0mm to 45.0mm



316L S.Steel Body / 304 S.Steel Actuator

Pipe Mounting

Normally Closed

Size	Port Size	Orifice Ø mm	Actuator mm	KV m³/h	Operating Pressure Differential bar	Minimum Pilot Control Pressure Range bar	Fluid Temperature		Parker Valves
							Min. C°	Max. C°	Valve Reference
DN10	3/8"	13	32	4.7	0-6	5-6	-10	180	PA10C2G3R032S
		13	32	4.7	0-6	5-6	-10	100	PA10C4G3R032S
		13	50	4.7	0-16	4.5	-10	180	PA10SAG3R050S
DN15	1/2"	13	32	4.7	0-6	5-6	-10	180	PA15C2G4R032S
		13	32	4.7	0-6	5-6	-10	100	PA15C4G4R032S
		13	50	4.7	0-16	4.5	-10	180	PA15SAG4R050S
DN20	3/4"	15	32	5.4	0-4	5-6	-10	180	PA20C2G5R032S
		15	32	5.4	0-4	5-6	-10	100	PA20C4G5R032S
		18	50	9.0	0-10	4.5	-10	180	PA20SAG5R050S
DN25	1"	24	63	16.0	0-8	4.5	-10	180	PA25SAG6R063S
DN32	1-1/4"	31	80	24.0	0-11	4	-10	180	PA32SAG7R080S
DN40	1-1/2"	35	80	32.0	0-8	4	-10	180	PA40SAG8R080S
		35	100	32.0	0-16	4	-10	180	PA40SAG8R100S
DN50	2"	45	100	50.0	0-9	4	-10	180	PA50SAG9R100S

316L S.Steel Body / Aluminium Actuator

Pipe Mounting

Normally Closed

Size	Port Size	Orifice Ø mm	Actuator mm	KV m³/h	Operating Pressure Differential bar	Minimum Pilot Control Pressure Range bar	Fluid Temperature		Parker Valves
							Min. C°	Max. C°	Valve Reference
DN10	3/8"	13	50	4.7	0-16	4.5	-10	180	PA10SAG3R050A
DN15	1/2"	13	50	4.7	0-16	4.5	-10	180	PA15SAG4R050A
DN20	3/4"	18	50	9.0	0-10	4.5	-10	180	PA20SAG5R050A
DN25	1"	24	63	16.0	0-8	4.5	-10	180	PA25SAG6R063A
DN32	1-1/4"	31	80	24.0	0-11	4	-10	180	PA32SAG7R080A
DN40	1-1/2"	35	80	32.0	0-8	4	-10	180	PA40SAG8R080A
		35	100	32.0	0-16	4	-10	180	PA40SAG8R100A
DN50	2"	45	100	50.0	0-9	4	-10	180	PA50SAG9R100A

Control & Operating Pressure

Please note : Charts do not apply for Valves with flow direction Under Seat. A minimum pressure as noted above is all that is required, up to a maximum of 10 bar.

Flow Diagram Under Seat

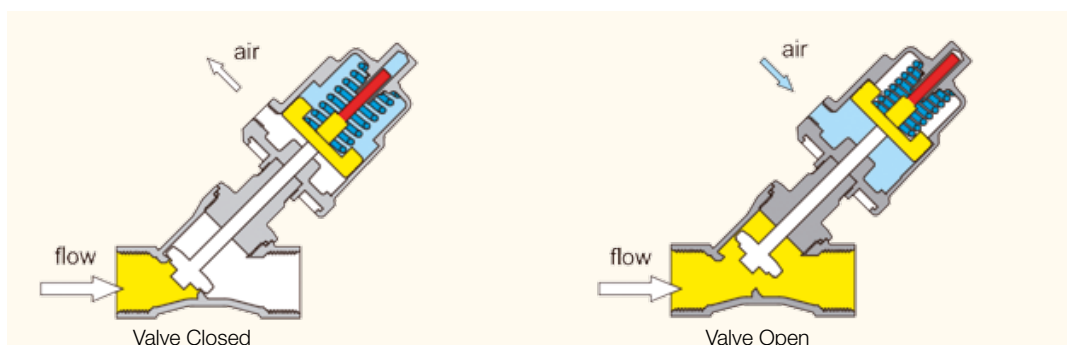

PA Series - Drawings and Dimensions

Stainless Steel Actuators Size 32 mm

Type	Actuator	Ø B	R	G1	K2		A2		G	L	T	SW
					Type C1/C2 (180°C)	Type C3/C4 (100°C)	Type C1/C2 (180°C)	Type C3/C4 (100°C)				
DN10	32	39.6	27	G1/8	107	94	117	106	G3/8	60	10	22 hexagon
DN15	32	39.6	27	G1/8	109	96	119	108	G1/2	65	11.5	25 hexagon
DN20	32	39.6	27	G1/8	112	100	126	115	G3/4	75	14	31 hexagon

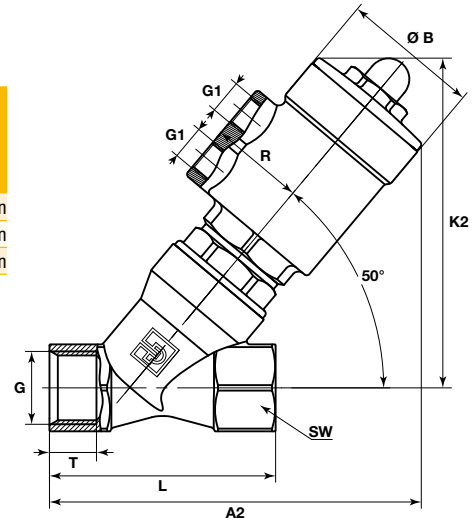

Stainless Steel Actuators Sizes 40, 50, 63, 80, 100 mm

Type	Actuator	D	R	P	K1	A1	G	L	T	SW
DN10	40	50.5	27	G1/8	116	121	G3/8	60	10	22 hexagon
	50	62	34	G1/8	130	133	G3/8	60	10	22 hexagon
DN15	40	50.5	27	G1/8	118	124	G1/2	65	11.5	25 hexagon
	50	62	34	G1/8	131	135	G1/2	65	11.5	25 hexagon
DN 20	50	62	34	G1/8	134	141	G3/4	75	14	31 hexagon
DN25	50	62	34	G1/8	141	153	G1	90	15	39 hexagon
	63	77	41.5	G1/8	164	175	G1	90	15	39 hexagon
DN32	63	77	41.5	G1/8	170	188	G1-1/4	110	18	50 octagon
	80	98	52	G1/4	184	205	G1-1/4	110	18	50 octagon
DN40	63	77	41.5	G1/8	181	201	G1-1/2	120	18	56 octagon
	80	98	52	G1/4	195	217	G1-1/2	120	18	56 octagon
DN50	100	121	63	G1/4	213	235	G1-1/2	120	18	56 octagon
	63	77	41.5	G1/8	189	216	G2	150	22	68 octagon
DN65	80	98	52	G1/4	203	233	G2	150	22	68 octagon
	100	121	63	G1/4	221	250	G2	150	22	68 octagon

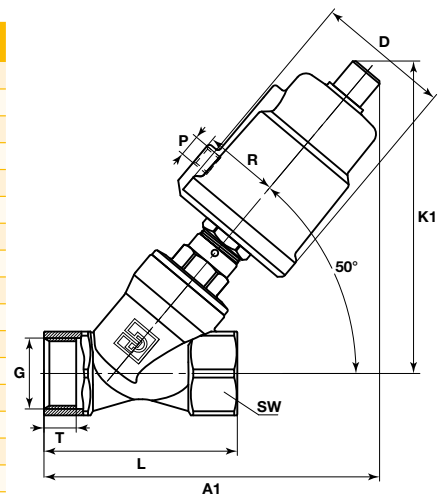

Aluminum Actuators Sizes 50, 63, 80, 100 mm

Type	Actuator	D	R	P	K1	A1	G	L	T	SW
DN10	50	61	38	G1/8	132	141	G3/8	60	10	22 hexagon
DN15	50	61	38	G1/8	133	144	G1/2	65	11.5	25 hexagon
DN20	50	61	38	G1/8	136	150	G3/4	75	14	31 hexagon
DN25	50	61	38	G1/8	144	162	G1	90	15	39 hexagon
	63	75	45	G1/8	167	183	G1	90	15	39 hexagon
DN32	63	75	45	G1/8	173	196	G1-1/4	110	18	50 octagon
	80	94	54	G1/4	192	214	G1-1/4	110	18	50 octagon
DN40	63	75	45	G1/8	184	209	G1-1/2	120	18	56 octagon
	80	94	54	G1/4	203	226	G1-1/2	120	18	56 octagon
DN50	100	115	64	G1/4	223	245	G1-1/2	120	18	56 octagon
	63	75	45	G1/8	192	224	G2	150	22	68 octagon
DN65	80	94	54	G1/4	211	242	G2	150	22	68 octagon
	100	115	64	G1/4	231	260	G2	150	22	68 octagon

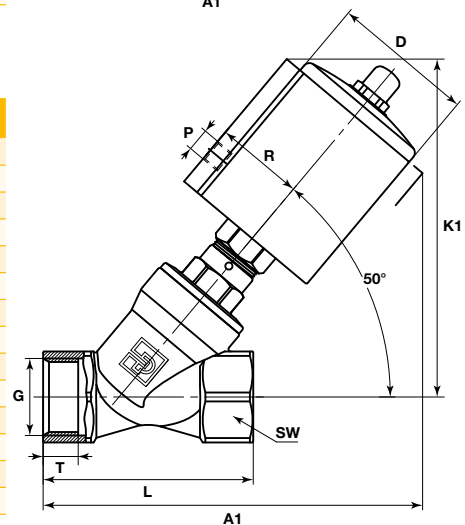

PA Series - 3 Way Direct Acting Pilot Solenoid Valves for Controlling the Angle Seat Valves



Banjo Valves G1/4" & G1/8" Series with Aluminium Body



Solenoid Operated B14-B04 Versions with 22 mm Coil

Port Size	Orifice	Q _n	Admissible differential pressure (bar) max.			Max. admissible fluid temperature (°C) Min. = -10°C Air & Neutral gases	Seat disc	Reference number			Consumption Power (Watt)		Weight (g)	Dim. Ref.
			min	DC=	AC=			Valve	Housing	Coil	DC	AC		
Banjo	G	mm	l/min											

3/2 Solenoid operated - Spring return (monostable)

1/8	1/8	1.2	50	0	10	10	50	NBR	131B14	-	496131	3	3	140	26
1/8	1/8	1.2	50	0	10	10	50	NBR	131B14	-	496482	3	3	150	26
1/8	1/8	1.2	50	0	10	10	50	NBR	131B14	-	496637	3	3	150	26
1/8	1/8	1.2	50	0	10	-	50	NBR	131B14	-	482605	5	-	170	26

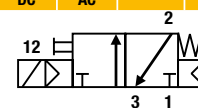

3/2 Solenoid operated - Spring return (monostable)

1/4	1/8	1.2	50	0	10	10	50	NBR	131B04	-	496131	3	3	160	27
1/4	1/8	1.2	50	0	10	10	50	NBR	131B04	-	496482	3	3	175	27
1/4	1/8	1.2	50	0	10	10	50	NBR	131B04	-	496637	3	3	175	27
1/4	1/8	1.2	50	0	10	-	50	NBR	131B04	-	482605	5	-	190	27

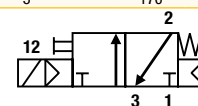

Dimensions Reference 26

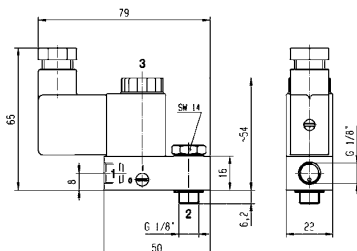

Dimensions Reference 27

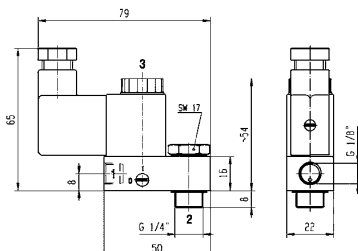

Banjo Valve Mounted to the valve

Coils 22 mm for Banjo Valves Series

These coils with connection for 2 P+G DIN 43650 B plug are encapsulated in synthetic material, conform to the IEC/CENELEC safety standards and comply with European low voltage directive 2006/95/EC. Banjo Valve bodies conform to the terms of the directive 94/9/CE specific to non electrical equipment for use within potentially explosive environments - Please select appropriate Coil for Safe Area or ATEX zones 1/21 or 2/22 in the following table.

- Power: 3 W or 5 W
- Insulation Class: F (155°C)
- Degree of Protection: IP65 (with plug)
- Duty Cycle: 100% ED

Available Voltages	Safe area without DIN plug Code	Safe area with DIN plug Code	For Zone 2/22 II 3 G-Ex nc AC IIC T5 II 3 D-Ex tc AC IIC - T 95°C code with DIN plug	For Zone 1/21 II 2 G-Ex mb II T4 II 2 D-Ex tb IIC - T 130°C code includes DIN plug and 1.5 m cable
12 VDC	496131 C1	496482 C1	496637 C1	482605 C1
24 VDC	496131 C2	496482 C2	496637 C2	482605 C2
48 VDC	496131 C4	496482 C4	496637 C4	-
110 VDC	496131 C5	496482 C5	496637 C5	-
24/50-60 VAC	496131 P0	496482 P0	496637 P0	-
48/50-60 VAC	496131 S4	496482 S4	496637 S4	-
110/50-60 VAC	496131 P2	496482 P2	496637 P2	-
115/60 VAC	496131 K8	496482 K8	496637 K8	-
230/50-60 VAC	496131 P9	496482 P9	496637 P9	-



Stainless Steel Air Preparation & Airline Accessories

Ball valves series



- Ball valves MB Series**
- One piece compact barstock design
 - Center off position for 3-way
 - 2-way, inline, angle; 3-way, 4-way and 5-way
 - Standard drop-in replacement
 - Patented seat design

- Ball valves B Series**
- 2-way, 3-way
 - Wide temperature application range
 - Widest variety of seats, seals and port connections

For more details refer to catalogue: 4121-BV

Diaphragm valve



- Diaphragm Valve NOVA Series**
- General purpose, high cycle, compact valve
 - For regular outlet valve, gas control panels and analyser sampling system applications.
 - Handwheel, lever and indicating handwheel options

For more details refer to catalogue: IPD 4515

Filter & Check valve



- Filter FT series**
- Filter elements are easily replaced without disconnecting the tube lines
 - Fast Loop bypass option enables a continuous self cleaning flow

- Check valves C series**
- Resilient, custom molded, seat design
 - Back stopped poppet to minimize spring stress
 - Cracking Pressures: 0.02 to 7 bar
 - Various port connections male and female BSP, NPT...

For more details refer to catalogue: IPD 4135-CV

Relief valve



- Professional Relief valve 20XXG series**
- Easy to adjust, precise setting variation
 - Easy to install, minimum size
 - Adjusting screw protected by user
 - Highest repeatability of cracking pressure
 - Minimized leakage preventing waste of media

For more details refer to catalogue: FCDE 5531UK

Quick-Acting Couplers



- Compact design
- Corrosion resistance
- Mainly used for applications in the areas of compressed air and liquids
- Optimally suited to use with liquid and aggressive media

For more details refer to catalogue: CAT/3800-Legris

FRLs



- Suitable for Marine & Offshore applications
- Chemical / Petroleum and process industries
- Coalescing filters are designed for removing oil and water aerosols down to 0.01µ
- Suitable for food industry applications

For more details refer to catalogue: PDE2504TCUK

Push-In Fittings



- Extreme chemical and mechanical resistance for severe conditions: food industry, chemicals, medical...
- Fittings suitable for permanent food contact
- Hygienic external design for reducing retention zones
- Proven gripping technology
- Manual connection and disconnection, no tools required
- 100 % leak-tested in production

For more details refer to catalogue: CAT/0570

Compression Fittings



- Excellent resistance to environmental conditions and corrosive fluids
- Pressure and temperature resistant
- Withstand strong vibration and water hammer

For more details refer to catalogue: CAT/0570

Coil Range for Stainless Steel Solenoid Valves

Table of Content

COILS

Coils 32mm for DIN plug connection	page 46
Coils with screw terminal.....	page 52
Coils 22mm for DIN plug connection	page 53

EXPLOSION PROOF ELECTRICAL PARTS

Level of protection "nAc nCc" "tc"	page 54
Level of protection "db" "tb"	page 64
Level of protection "mb" 22mm "tb"	page 65
Level of protection "mb" 50mm "tb"	page 61
Level of protection "db mb" "tb"	page 57
Level of protection "eb mb" "tb"	page 62
Level of protection "ia" "ta"	page 66

HOUSING 4538	page 70
--------------------	---------

Coil Range

COIL GROUP

2.0/2.1

COILS FOR
DIN PLUG CONNECTION



COILS 32 mm

These coils can be mounted with every Parker solenoid valves corresponding to the specified Coil Group. See column "Coil Group" within valve pages. This is an encapsulated assembly comprising a coil, integral magnetic iron path and snap-on plug connection.

The synthetic material encapsulation provides an effective compact housing, offering full protection against dust, oil, water, etc. Ease of mounting in confined space - offers shock and corrosion protection - simplifies conversion of existing equipment to other requirements, etc. Coils conform to the IEC/CENELEC safety standards and complies with European low-voltage directive.



Specification		Standard		Double frequency			
Ref. (without DIN plug) Ref. (with DIN plug)		481865 482725		483510 482635			
Coil Group		2.0 / 2.1					
Degree of protection		IP65 according to IEC / EN 60529 standards (with DIN plug).					
Class of insulation		F 155°C					
Electrical connection		The coil is connected with a 2 P + E plug according to EN 175301-803 type A					
Ambient temperature		-40°C to +50°C The application is limited also by the temperature range of the valve.					
Elect. Power	DC	Pn (hot)	9 W		-		
		P (cold) 20°C	12 W		-		
	AC	Pn (holding)	8 W		9 W		
		Attraction cold	26 VA (9 W)		32 VA (10 W)		
Weight		130 g (without plug)					
Voltages "Un"		VAC/Hz	Code	VDC	Code	VAC/Hz	Code
-10% to +10% of the Un		24/50	A2	12	C1	24/50, 24/60	P0
		48/50	A4	24	C2	48/50, 48/60	S4
		110/50	A5	48	C4	110-115/50, 120/60	S5
		220-230/50	3D	110	C5	220-240/50, 240/60	S6
		230/60	J3				

To Order a Coil choose Coil Ref + Voltage Code, example: 481865 for 24 VDC = 481865C2
More voltage possibilities can be found in the table of voltage codes at the end of the coil section.

These coils must be used with suitable housings, see example below:

The coil assembly kit Ref. 2995 corresponds to the "housing" of Lucifer® valve numbering system (Valve - housing - coil/voltage).

It is composed of a nameplate giving details of the valve type, a round washer and a nut to ensure the fixing between 32 mm coil and the valve.

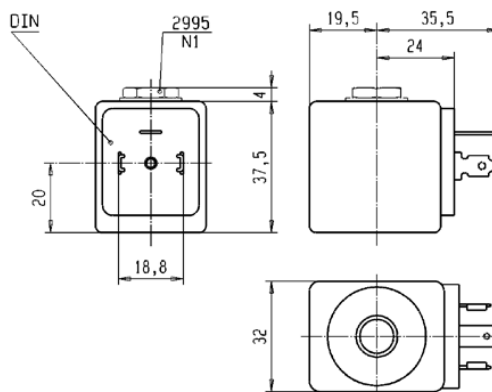

Coil Range

COIL GROUP
2.0/2.1
2.2

**COILS FOR
DIN PLUG CONNECTION**



HIGH TEMPERATURE COILS 32 mm

These coils can be mounted with every Parker solenoid valves corresponding to the specified Coil Group. See column "Coil Group" within valve pages. This is an encapsulated assembly comprising a coil, integral magnetic iron path and snap-on plug connection.

The synthetic material encapsulation provides an effective compact housing, offering full protection against dust, oil, water, etc. Ease of mounting in confined space - offers shock and corrosion protection - simplifies conversion of existing equipment to other requirements, etc. Coils conform to the IEC/CENELEC safety standards and complies with European low-voltage directive.



Specification		High temperature			High temp. + high power				
Ref. (without DIN plug)		492453			492425				
Ref. (with DIN plug)		492726			492727				
Coil Group		2.0 / 2.1			2.0 / 2.2				
Degree of protection		IP65 according to IEC / EN 60529 standards (with DIN plug).							
Class of insulation		H 180°C							
Electrical connection		The coil is connected with a 2 P + E plug according to EN 175301-803 type A							
Ambient temperature		-40°C to +50°C The application is limited also by the temperature range of the valve.							
Elect. Power	DC	Pn (hot)	9 W			14 W			
		P (cold) 20°C	12 W			21 W			
	AC	Pn (holding)	8 W			14 W			
		Attraction cold	26 VA (9 W)			55 VA (18 W)			
Weight		130 g (without plug)							
Voltages "Un"		VAC/Hz	Code	VDC	Code	VAC/Hz	Code	VDC	Code
-10% to +10% of the Un		24/50	A2	12	C1	24/50	A2	24	C2
		48/50	A4	24	C2	110/50	A5		
		110/50	A5	48	C4	230/50	F4		
		220/50-230/50	3D	110	C5				

To Order a Coil choose Coil Ref + Voltage Code, example: 492453 for 24VDC= **492453C2**
More voltage possibilities can be found in the table of voltage codes at the end of the coil section.

These coils must be used with suitable housings, see example below:

The coil assembly kit **Ref. 2995** corresponds to the "housing" of Lucifer® valve numbering system (Valve - housing - coil/voltage).

It is composed of a nameplate giving details of the valve type, a round washer and a nut to ensure the fixing between 32 mm coil and the valve.

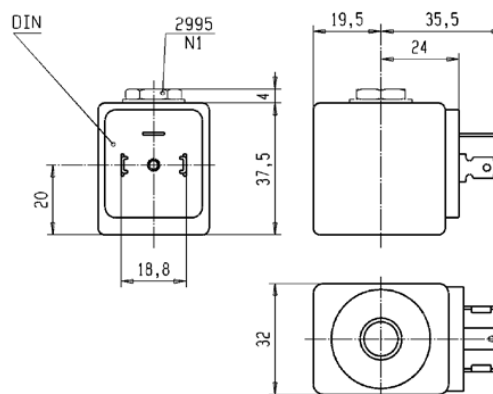

Coil Range

COIL GROUP
6.0

**COILS FOR
DIN PLUG CONNECTION**



LOW POWER COIL 32 mm

These coils can be mounted with every Parker solenoid valves corresponding to the specified Coil Group.

See column "Coil Group" within valve pages.

This is an encapsulated assembly comprising a coil, integral magnetic iron path and snap-on plug connection.

The synthetic material encapsulation provides an effective compact housing, offering full protection against dust, oil, water, etc. Ease of mounting in confined space - offers shock and corrosion protection - simplifies conversion of existing equipment to other requirements, etc. Coils conform to the IEC/CENELEC safety standards and complies with European low-voltage directive.



Specification		Miniwatt	
Reference (without DIN plug)		482740	
Reference (with DIN plug)		482745	
Coil Group		6.0	
Degree of protection		IP65 according to IEC / EN 60529 standards (with DIN plug).	
Class of insulation		F 155°C	
Electrical connection		The coil is connected with a 2 P + E plug according to EN 175301-803 type A	
Ambient temperature		-40°C to +50°C The application is limited also by the temperature range of the valve.	
Elect. Power	DC	Pn (hot)	1.6 W
		P (cold) 20°C	2.1 W
	AC	Pn (holding)	-
		Attraction cold	-
Weight		130 g (without plug)	
Voltages "Un"		VDC	Code
-10% to +10% of the Un		24	C2
		48	C4
		110	C5

To Order a Coil choose Coil Ref + Voltage Code, example: 482740 for 24 VDC = **482740C2**
More voltage possibilities can be found in the table of voltage codes at the end of the coil section.

These coils must be used with suitable housings, see example below:

The coil assembly kit **Ref. 2995** corresponds to the "housing" of Lucifer® valve numbering system (Valve - housing - coil/voltage).

It is composed of a nameplate giving details of the valve type, a round washer and a nut to ensure the fixing between 32 mm coil and the valve.

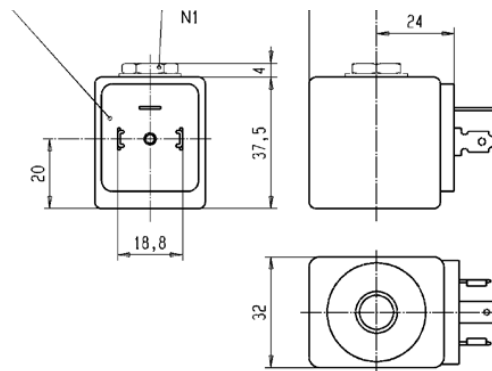

Coil Range

COIL GROUP

24.0

COILS FOR
DIN PLUG CONNECTION



D5 COIL SERIES 32 mm

Encapsulated in synthetic material, Connector for 2P+E according with DIN EN 175301-803, Form A, IP65 degree of protection to be considered with connector plug only.

This coil conforms to the IEC/GENELEC safety standards and complies with European low-voltage directive.
DIN plug connector to be ordered separately (see coil accessories section).



Specification		Mono Frequency VDE Coil			
Reference (without DIN plug)		D5 Series			
Coil group		24.0			
Degree of protection		IP65 according to IEC / EN 60529 standards (with DIN plug)			
Class of insulation		F 155°C			
Electrical connection		The coil is connected with a 2 P + E plug according to EN 175301-803 type A.			
Ambient temperature		-40°C to +50°C The application is limited also by the temperature range of the valve.			
Elect. Power	DC	Pn (hot)	9 W		
		P (cold) 20°C	-		
	AC	P (cold) 20°C	8 W		
		Attraction cold	26 VA		
Weight		130 g			
Voltages "Un"		VAC/Hz	Code	VDC	Code
-10% to +10% of Un for AC - 5 % to + 10 % for Un DC.		24/50	D5H	24	D5B
		110/50	D5XA5		
		220-230/50	D5L		
		24/60	D5E		
		230/60	D5XJ3		
		115/60	D5XK8		

To Order a Coil: Use 6 digits ordering number - example: D5 for 24 VAC/60 Hz = D5E
More voltage possibilities can be found in the table of voltage codes at the end of the coil section.

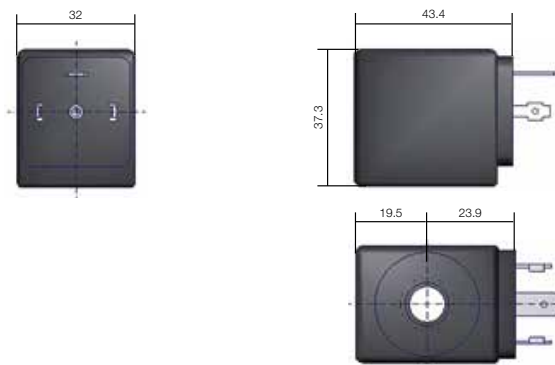

Coil Range

COIL GROUP
24.0

COILS FOR
DIN PLUG CONNECTION



HIGH TEMPERATURE COILS 32 mm

These coils can be mounted with any Parker solenoid valves whereas specified Coil Group is indicated.

See column "Coil Group" within valve pages.

The synthetic material encapsulation provides an effective compact housing, offering full protection against dust, oil, water, etc.

Ease of mounting in confined space - offers shock and corrosion protection - simplifies conversion of existing equipment to other requirements, etc.

Coils conform to the IEC/CENELEC safety standards and complies with 2006/95/EC European low-voltage directive.



Specification		High temp. + high power			
Ref. (without DIN plug)		DM			
Coil Group		24			
Degree of protection		IP65 according to IEC / EN 60529 standards (with DIN plug).			
Class of insulation		H 180°C			
Electrical connection		The coil is connected with a 2 P + E plug according to EN 175301-803 type A			
Ambient temperature		-40°C to +50°C The application is limited also by the temperature range of the valve.			
Elect. Power	DC	Pn (hot)	14 W		
		P (cold) 20°C	21 W		
	AC	Pn (holding)	14 W		
		Attraction cold	55 VA (18 W)		
Weight		130 g (without plug)			
Voltages "Un"		VAC/Hz	Code	VDC	Code
-10% to +10% of the Un		24/50 110/50 230/50	H J K	24	B

To Order a Coil : Use coil reference DM and add Voltage Code, example: DM for 24VDC= DMB

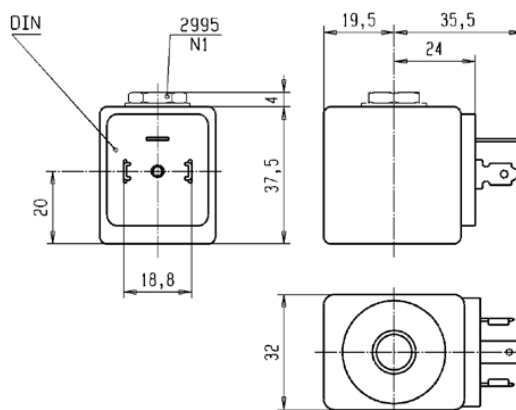

Coil Range

COIL GROUP

10.1

COILS FOR
DIN PLUG CONNECTION



COIL FOR OIL AND GAS 37 mm

This coil can be mounted with every Parker solenoid valves corresponding to the specified Coil Group.

See column "Coil Group" within valve pages.

This is an encapsulated assembly comprising a coil, integral magnetic iron path and snap-on plug connection.

The synthetic material encapsulation provides an effective compact housing, offering full protection against dust, oil, water, etc.

Ease of mounting in confined space - offers shock and corrosion protection - simplifies conversion of existing equipment to other requirements, etc.

Coils conform to the IEC/CENELEC safety standards and complies with European low-voltage directive. DIN plug connector included.



Specification		Coil for Oil and Gas			
Reference (with DIN plug)		496895			
Coil group		10.1			
Degree of protection		IP65 according to IEC / EN 60529 standards			
Class of insulation		H 180°C			
Electrical connection		With DIN plug 492459 (AC) or 486586 (DC)			
Ambient temperature		-40°C to +50°C The application is limited also by the temperature range of the valve.			
Elect. Power	DC	Pn (hot)	8 W		
		P (cold) 20°C	-		
	AC	Pn (holding)	8 W		
		Attraction cold	-		
Weight		273 g			
Voltages "Un"		VAC/Hz	Code	VDC	Code
-10% to +10% of the Un		230/50-60	P9	24	C2
		110/50-60	P2	48	C4
		24/50-60	P0	110	C5
		48/50-60	S4		

To Order a Coil choose Coil Ref + Voltage Code, example: 496895 for 24VDC = **496895C2**
More voltage possibilities can be found in the table of voltage codes at the end of the coil section.
The fixing nut (housing kit) is already included in the coil kit.

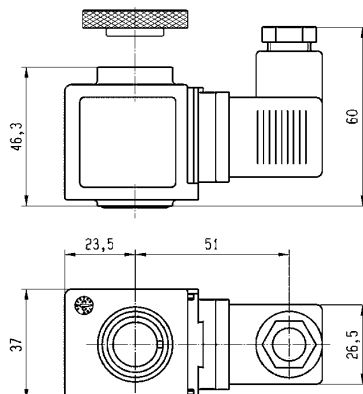

Coil Range

COIL GROUP
2.0/2.1

**COILS WITH
SCREW TERMINALS**



STANDARD COILS 40 mm

These coils can be mounted with every Parker Solenoid Valves corresponding to the specified Coil Group.

See column "Coil Group" within valve pages. They can be mounted with all metal housings.

The coil winding is completely encapsulated in synthetic material. Easy mounting in confined spaces. Electrical connection with screw terminals for wire up to 1.5 mm².

Coils conform to the IEC/GENELEC safety standards and complies with European low-voltage directive.



Specification		Standard			Double Frequency		
Reference		481000			483520		
Coil Group		2.0 / 2.1					
Class of insulation		F 155°C					
Ambient temperature		-40°C to +50°C The application is limited also by the temperature range of the valve..					
Elect. Power	DC	Pn (hot)	8W			-	
		P (cold) 20°C	9W			-	
	AC	Pn (holding)	8W			9W	
		Attraction cold	32 VA (9 W)			36 VA (10 W)	
Weight		130 g			130 g		
Voltages "Un"		VAC/Hz	Code	VDC	Code	VAC/Hz	Code
-10% to +10% of the Un		24/50	A2	24	C2	24/50-60	P0
(-15 % to +5 %		48/50	A4	48	C4	220-240/50-240/60	S6
for double-frequency coil		110/50-115/50	0A	110	C5		
with voltage code		220/50-230/50	3D				
S6 if 240 V/50/Hz is used).							

To Order a Coil choose Coil Ref + Voltage Code, example: 4828 for 24 VDC = **481000C2**
More voltage possibilities can be found in the table of voltage codes at the end of the coil section.

These coils must be used with suitable housings, see examples below:

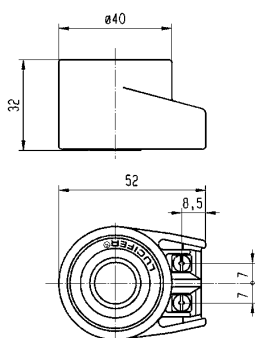

Ref. 4270 - Protection IP 44 according to IEC / EN 60529 standard (with cable gland)



Ref. 4538 - Protection IP 67 according to IEC / EN 60529 standard



Coil Range

COIL GROUP

1.1

COILS FOR
DIN PLUG CONNECTION



COILS 22 mm

These coils can be mounted with any Parker solenoid valves corresponding to the specified Coil Group. See column "Coil Group" within valve pages.

This coil is designed for valves equipped with a miniature tube assembly (2000 series valves). This is an encapsulated assembly comprising a coil, integral magnetic iron path and snap-on plug connection.

The synthetic material encapsulation provides an effective compact housing, offering full protection against dust, oil, water, etc.

Ease of mounting in confined space - offers shock and corrosion protection - simplifies conversion of existing equipment to other requirements, etc.

Coil conforms to the IEC/CENELEC safety standards and complies with 2006/95/EC European low-voltage directive.



Specification		Low power	High power						
Ref. (without DIN plug)		DF	DG						
Coil Group		1.1							
Degree of protection		IP65 according to IEC / EN 60529 standards (with DIN plug).							
Class of insulation		F 155°C							
Electrical connection		The coil is connected with a 2 P + E plug according to EN 175301-803 type B.							
Ambient temperature		-40°C to +50°C The application is limited also by the temperature range of the valve.							
Elect. Power	DC	Pn (hot)	2.5 W	5 W					
		P (cold) 20°C	3 W	6.5 W					
	AC	Pn (holding)	2 W	4 W					
		Attraction cold	5.7 VA (2.5 W)	8.9 VA (5 W)					
Weight		100 g with DIN Plug							
Voltages "Un"		VAC/Hz	Code	VDC	Code	VAC/Hz	Code	VDC	Code
-10% to +10% of the Un		24/50 220-230/50 110/50-115/50	H L J	24	B	24/50 110/50-115/50 220/50-230/50	H J L	24	B

To Order a Coil choose Coil Ref + Voltage Code, example: DG for 24VDC = DGB

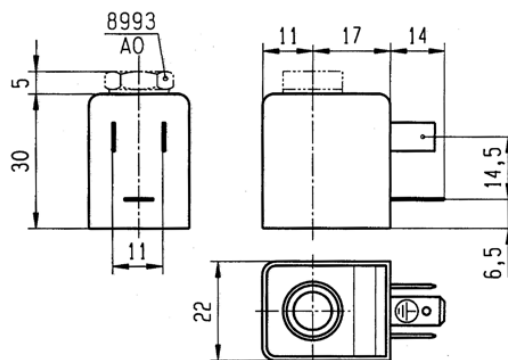

Coil Range

ZONE 2/22

COIL GROUP
2.0/2.1

EXPLOSION PROOF ELECTRICAL PARTS
NON SPARKING PROTECTION
ELECTRICAL PARTS "nAc nCc"



ELECTRICAL PART 32 mm

These coils can be mounted with every Parker ATEX solenoid valves corresponding to the specified Coil Group. See column "Coil Group" within valve pages.

Application: Control of solenoid valves in dangerous areas where explosion-proof protection Ex nAc nCc IIC T3/T4 is required. Ease of mounting in confined space - offers shock and corrosion protection-simplifies conversion of existing equipment to other requirements, etc.

Benefits:

The synthetic material encapsulation of the coil provides an effective compact housing, offering full protection against dust, oil, water, etc. Small size for ease of mounting in confined spaces.



Reference	495870				496110		
Certificate	LCIE 05 ATEX 6003 X						
Coil Group	2.0 / 2.1						
Type of protection	Gas	II 3 G Ex nAc nCc IIC T3/T4			II 3 G Ex nAc nCc IIC T3/T4		
	Dust	II 3 D - Ex tc IIIC - T195°C / T130°C			II 3 D - Ex tc IIIC - T195°C / T130°C		
Degree of protection	IP65 (with plug) according to IEC/EN 60529 Standards						
Insulation Class	F (155°C)						
Duty cycle	100%						
Ambiant temperature	-40°C to +65°C / 50°C The application is limited also by the temperature range of the valve.						
Elect. Power	DC	Pn (hot)	9 W			-	
		P (cold) 20°C	12 W			-	
	AC	Pn (holding)	8 W			9 W	
		Attraction cold	26 VA (9 W)			32 VA (10 W)	
Weight	150 g						
Voltages "Un" -10% to +10% of the Un	VAC/Hz	Code	VDC	Code	VAC/Hz	Code	
	24/50	A2	24	C2	24/50-60	P0	
	48/50	A4	48	C4	48/50-60	S4	
	110/50	A5	110	C5	110/50-60	S5	
	220-230/50	3D			220/50-60	S6	

To Order a Coil choose Coil Ref + Voltage Code, example: 495870 for 24 VDC = **495870C2**

These coils must be used with suitable housings, see example below:

The coil assembly kit **Ref. 2995** corresponds to the "housing" of Lucifer® valve numbering system (Valve - housing - coil/voltage).

It is composed of a nameplate giving details of the valve type, a round washer and a nut to ensure the fixing between 32 mm coil and the valve.

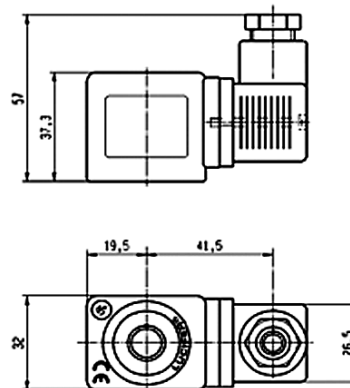

Coil Range

COIL GROUP

6.0

EXPLOSION PROOF ELECTRICAL PARTS

NON SPARKING PROTECTION
ELECTRICAL PARTS "nAc nCc"



ZONE 2/22

ELECTRICAL PART LOW POWER 32 mm

This coil can be mounted with every Parker ATEX solenoid valves corresponding to the specified Coil Group. See column "Coil Group" within valve pages.

Application: Control of solenoid valves in dangerous areas where explosion-proof protection Ex nAc nCc IIC T5/T6 is required. Ease of mounting in confined space - offers shock and corrosion protection - simplifies conversion of existing equipment to other requirements, etc.

Benefits:

The synthetic material encapsulation of the coil provides an effective compact housing, offering full protection against dust, oil, water, etc. Small size for ease of mounting in confined spaces.



Reference	496125		
Certificate	LCIE 05 ATEX 6003 X		
Coil group	6.0		
Type of protection	Gas	II 3 G Ex nAc nCc IIC T5/T6	
	Dust	II 3 D Ex tc IIIC T95°C/80°C	
Degree of protection	IP65 (with plug) according to IEC/EN 60529 Standards		
Insulation Class	F (155°C)		
Duty cycle	100%		
Ambiant temperature	-40°C to +65°C / 50°C The application is limited also by the temperature range of the valve.		
Elect. Power	DC	Pn (hot)	1.6 W
		P (cold) 20°C	2.1 W
	AC	Pn (holding)	-
		Attraction cold	-
Weight	150 g		
Voltages "Un" -10% to +10% of the Un	VDC		Code
		24	C2
		48	C4
		110	C5

To Order a Coil choose Coil Ref + Voltage Code, example: 496125 for 24 VDC = 496125C2

These coils must be used with suitable housings, see example below:

The coil assembly kit Ref. 2995 corresponds to the "housing" of Lucifer® valve numbering system (Valve - housing - coil/voltage).

It is composed of a nameplate giving details of the valve type, a round washer and a nut to ensure the fixing between 32 mm coil and the valve.

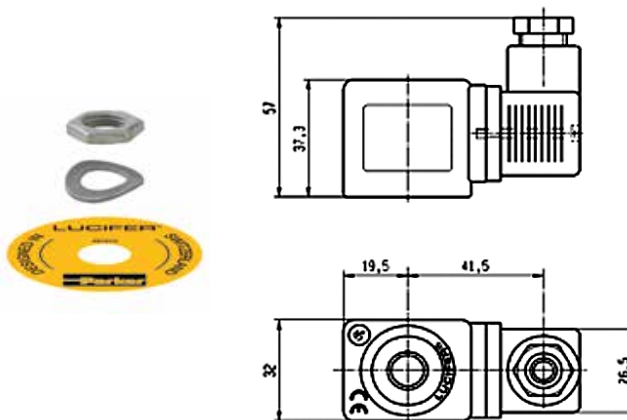

Coil Range

ZONE 2/22

COIL GROUP
1.2

EXPLOSION PROOF ELECTRICAL PARTS
NON SPARKING PROTECTION
ELECTRICAL PARTS "nAc nCc"



ELECTRICAL PART DOUBLE FREQUENCY 22 mm

This coil can be mounted with every Parker ATEX solenoid valves corresponding to the specified Coil Group.

See column "Coil Group" within valve pages.

Application:

Control of solenoid valves in dangerous areas where explosion-proof protection Ex nAc nCc IIC T5 is required.

Benefits:

The synthetic material encapsulation of the coil provides an effective compact housing, offering full protection against dust, oil, water, etc. Small size for ease of mounting in confined spaces.



Specification		Double Frequency			
Reference		496637			
Certificate		ATEX			
Coil group		1.2			
Type of protection	Gas	Ex nAc nCc IIC T5			
	Dust	II 3 D - Ex tc IIIC - T 95°C			
Degree of protection		IP65 (with plug) according to IEC/EN 60529 Standards			
Ambiant temperature		-20°C to +50°C The application is limited also by the temperature range of the valve.			
Insulation Class		F 155°C			
Elect. Power	DC	Pn (hot)	3 W		
		P (cold) 20°C	-		
	AC	Pn (holding)	3 W		
		Attraction cold	5.7 VA (2.5 W)		
Weight		75 g			
Voltages "Un"		VAC/Hz	Code	VDC	Code
-10% to +10% of the Un		24/50-60	P0	24 V	C2
		110/50-60	P2	48 V	C4
		230/50-60	P9	110 V	C5
		48/50-60	S4		

To Order a Coil choose Coil Ref + Voltage Code, example: 496637 for 24 VDC = 496637C2

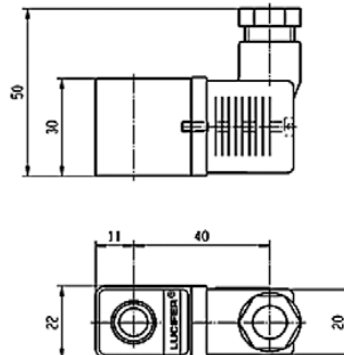

Coil Range

COIL GROUP

2.0/2.1

EXPLOSION PROOF ELECTRICAL PARTS

FLAME PROOF ENCAPSULATED ELECTRICAL PARTS "db mb"

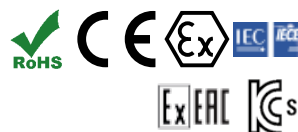

ZONE 1/21

495905 - ELECTRICAL PARTS 37 mm

These coils can be mounted with every Parker ATEX solenoid valves corresponding to the specified Coil Group.

See column "Coil Group" within valve pages.

Application: Control of solenoid valves in dangerous areas where explosion-proof protection Ex db mb IIC T4 is required.

Benefits: Rotatable 360° fibreglass-reinforced plastic housing (class H). Solenoid coil, rectifier (silicium diodes), fuses and varistor protection are completely encapsulated into the coil housing by epoxy resin for shock and corrosion protection. The plastic housing is delivered with M20 x 1.5 cable gland certified for use "db" protection. Small size for ease of mounting in confined space.



Reference	495905		49590505*	
Certificate	LCIE 03 ATEX 6451 X - IECEx LCI 06.0004 X			
Coil Group	2.0 / 2.1			
Type of protection	Gas	II 2 G - Ex db mb IIC T4		
	Dust	II 2 D - Ex tb IIIC - 130°C		
Degree of protection	IP67 according to IEC/EN 60529 Standards			
Ambient temperature	-40°C to +80°C The application is limited also by the temperature range of the valve.			
Class of insulation	H (180 °)			
Electrical connection	Electric connection is done in the connection box on an easily accessible connector terminals. The introduction of the cable (Ø min 5 mm, Ømax. 11 mm, section max. 2.5 mm²) in the connection box passes by the built in M20 x 1.5 cable gland.			
Elect. Power	DC	Pn (hot)	8 W	
		P (cold) 20°C	9 W	
	AC	Pn (holding)	8 W	
		Attraction cold	9 W	
Voltages "Un"	VAC/Hz	Code	VDC	Code
-10% to +10% of Un for AC	24/50	A2	24	C2
-10% to +10% for Un DC	48/50	A4	48	C4
	115/50	E5	110	C5
	230/50	F4		

To Order a Coil choose Coil Ref + Voltage Code, example: 495905 for 24 VDC = 495905C2

* 49590505 available only in C4

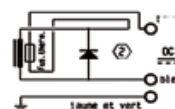
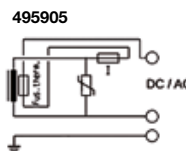
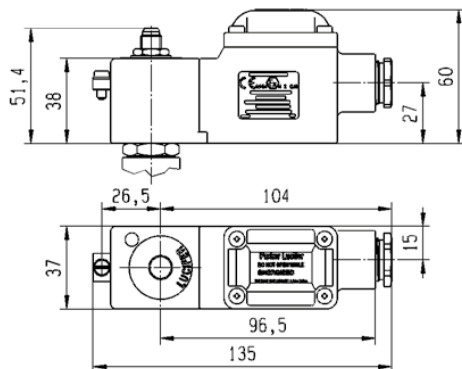

Coil Range

ZONE 1/21

COIL GROUP
6.0

EXPLOSION PROOF ELECTRICAL PARTS
FLAME PROOF ENCAPSULATED
ELECTRICAL PARTS "db mb"



495900 - LOW POWER ELECTRICAL PARTS 37 mm

This coil can be mounted with every Parker ATEX solenoid valves corresponding to the specified Coil Group. See column "Coil Group" within valve pages.

Application: Control of solenoid valves in dangerous areas where explosion-proof protection Ex db mb IIC T4 to T6 is required.

Benefits: Rotatable 360° fibreglass-reinforced plastic housing (class H). Solenoid coil, rectifier (silicium diodes), fuses and varistor protection are completely encapsulated into the coil housing by epoxy resin for shock and corrosion protection. The plastic housing is delivered with M20 x 1.5 cable gland certified for use "db" protection. Small size for ease of mounting in confined space.



Reference		495900 (VAC)		495900 (VDC)	
Certificate		LCIE 03 ATEX 6451 X - IECEx LCI 06.0004 X			
Coil Group		6.0			
Type of protection	Gas	II 2 G - Ex db mb IIC T4 / T5 / T6		II 2 G - Ex db mb IIC T4 / T5 / T6	
	Dust	II 2 D Ex tb IIIC - 130°C / 95°C / 80°C		II 2 D Ex tb IIIC - T130°C / 95°C / 80°C	
Degree of protection		IP67 according to IEC/EN 60529 Standards			
Ambient temperature		-40°C to +80°C / 55°C / 40°C		-40°C to +80°C / 65°C / 55°C	
		The application is limited also by the temperature range of the valve.			
Class of insulation		H (180 °)			
Electrical connection		Electric connection is done in the connection box on an easily accessible connector terminals. The introduction of the cable (Ø min 5 mm, Ømax. 11 mm, section max. 2.5 mm²) in the connection box passes by the built in M20 x 1.5 cable gland			
Elect. Power	DC	Pn (hot)	-	2 W	
		P (cold) 20°C	-	2.5 W	
	AC	Pn (holding)	2.5 W	-	
		Attraction cold	3 W	-	
Voltages "Un"		VAC/Hz	Code	VDC	Code
-10% to +10% of Un for AC		24/50	A2	24	C2
- 10 % to + 10 % for Un DC.		48/50	A4	48	C4
		115/50	E5	110	C5
		230/50	F4		

To Order a Coil: Coil Ref + Voltage Code, example: 495900 for 24 VDC = **495900C2**

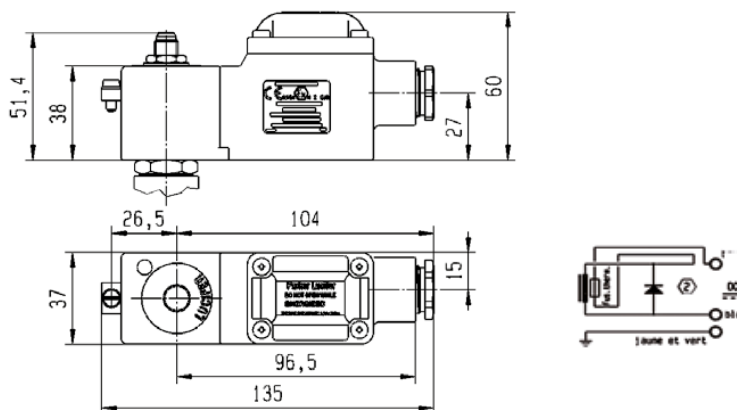

Coil Range

COIL GROUP
10.1/10.2

EXPLOSION PROOF ELECTRICAL PARTS
FLAME PROOF ENCAPSULATED ELECTRICAL PARTS "db mb"

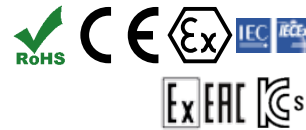

ZONE 1/21

496700 & 496800 - ELECTRICAL PARTS 37 mm

These coils can be mounted with every Parker ATEX solenoid valves corresponding to the specified Coil Group.
See column "Coil Group" within valve pages.

Application: Control of solenoid valves in dangerous areas where explosion-proof protection Ex db mb IIC T4 to T6 is required.

Benefits: Rotatable 360° fibreglass-reinforced plastic housing (class H). Solenoid coil, rectifier (silicium diodes), fuses and varistor protection are completely encapsulated into the coil housing by epoxy resin for shock and corrosion protection. The plastic housing is delivered with 1/2" NPT or M20 x 1.5 threaded hole for wide range of cable glands. Small size for ease of mounting in confined space.



Reference		496700 or 496700.02 (NPT)			496800 or 496800.02 (NPT)				
Certificate		LCIE 10 ATEX 3059 X - IECEx LCI 10.0023X							
Coil Group		10.2			10.1				
Type of protection	Gas	II 2 G - Ex db mb IIC T4 / T5 / T6			II 2 G - Ex db mb IIC T4				
	Dust	II 2 D - Ex tb III C - T130 / 95 / 80°C			II 2 D - Ex tb III C - T130°C				
Degree of protection		IP67 according to IEC/EN 60529 Standards							
Ambiant temperature		-40°C to +35°C / +50°C / +65°C			-40°C to +65°C				
Class of insulation		The application is limited also by the temperature range of the valve. H (180°)							
Electrical connection		Electric connection is done in the connection box passes through a 1/2 NPT or M20x1.5 thread in which a certified Ex dBIIC cable gland must be installed							
Elect. Power	DC	Pn (hot)	-	6 W	-	-	8 W		
		P (cold) 20°C	-	7.5 W	-	-	10.5 W		
	AC	Pn (holding)	6 W	-	-	8 W	-		
		Attraction cold	7.5 W	-	-	10.5 W	-		
Voltages "Un"		VAC/Hz	Code	VDC	Code	VAC/Hz	Code	VDC	Code
-10% to +10% of the Un		230/50-60	P9	24	C2	230/50-60	P9	24	C2
		110/50-60	P2	48	C4	110/50-60	P2	48	C4
		24/50-60	P0	110	C5	24/50-60	P0	110	C5
		48/50-60	S4	-	-	48/50-60	S4	-	-

To Order a Coil choose Coil Ref + Voltage Code, example: 496700 for 24 VDC = **496700C2**

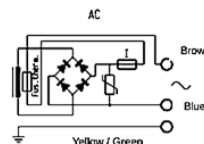
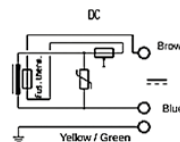
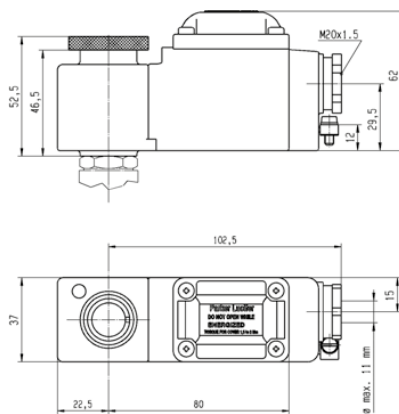

Coil Range

ZONE 1/21

COIL GROUP
10.2/10.1

EXPLOSION PROOF ELECTRICAL PARTS
FLAME PROOF ENCAPSULATED ELECTRICAL PARTS "db mb"



496555 & 496560 - ELECTRICAL PARTS 37 mm

These coils can be mounted with every Parker ATEX solenoid valves corresponding to the specified Coil Group.
See column "Coil Group" within valve pages.

Application: Control of solenoid valves in dangerous areas where explosion-proof protection Ex db mb IIC T4 to T6 is required.

Benefits: Rotatable 360° fibreglass-reinforced plastic housing (class H). Solenoid coil, rectifier (silicium diodes), fuses and varistor protection are completely encapsulated into the coil housing by epoxy resin for shock and corrosion protection. The plastic housing is delivered with M20 x 1.5 cable gland certified for use "db" protection. Small size for ease of mounting in confined space.



Reference	496555				496560				
Certificate	LCIE 07 ATEX 6075 X - IECEx LCI 07.0014X								
Coil Group	10.2				10.1				
Type of protection	Gas	II 2 G - Ex db mb IIC T4 / T5 / T6				II 2 G - Ex db mb IIC T4			
	Dust	II 2 D - Ex tb IIC - T130°C / 95°C / 80°C				II 2 D - Ex tb IIC - T130°C			
Degree of protection	IP 67 according to IEC/EN 60529 Standards								
Ambiant temperature	-40°C to +65 / 50 / 35°C				-40°C to +65°C				
The application is limited also by the temperature range of the valve.									
Class of insulation	H (180 °)								
Electrical connection	Electric connection is done in the connection box on an easily accessible connector terminals. The introduction of the cable (Ø min 5 mm, Ømax. 11 mm, section max. 2.5 mm²) in the connection box passes by the built in M20 x 1.5 cable gland.								
Elect. Power	DC	Pn (hot)	-	6 W	-	8 W			
		P (cold) 20°C	-	7.5 W	-	10.5 W			
	AC	Pn (holding)	6 W	-	8 W	-	-		
		Attraction cold	7.5 W	-	10.5 W	-	-		
Voltages "Un"		VAC/Hz	Code	VDC	Code	VAC/Hz	Code	VDC	Code
-10% to +10% of the Un		230/50-60	P9	24	C2	230/50-60	P9	24	C2
		110/50-60	P2	48	C4	110/50-60	P2	48	C4
		24/50-60	P0	110	C5	24/50-60	P0	110	C5
		48/50-60	S4			48/50-60	S4		

To Order a Coil choose Coil Ref + Voltage Code, example: 496555 for 24 VDC = **496555C2**

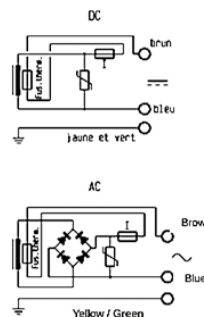
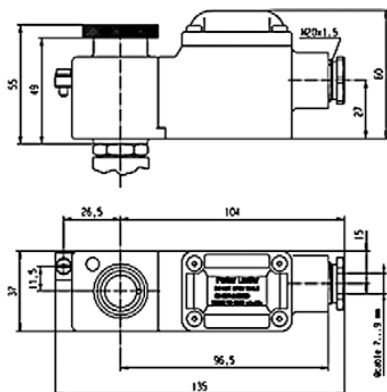

Coil Range

COIL GROUP

2.0/2.1

EXPLOSION PROOF ELECTRICAL PARTS



ENCAPSULATED ELECTRICAL PARTS "mb"

ZONE 1/21

WITH WATER PROOF METAL HOUSING 50 mm

These coils can be mounted with every Parker ATEX solenoid valves corresponding to the specified Coil Group.

See column "Coil Group" within valve pages.

Application: Control of solenoid valves in dangerous areas where explosion-proof protection Ex mb IIC T4/ T5 is required.

Benefits: Epoxy-vernished steel housing - solenoid coil, rectifier (silicium diodes), fuse and varistor protection element are completely encapsulated in the coil housing by means of epoxy resin. Small size for ease of mounting in confined space. Simplifies conversion of existing equipment to hazardous area requirements.



Reference	492070 (with 3 m cable length) 492070160 (with 6 m cable length)			
Certificate	LCIE 02 ATEX 6017 X - IECEx LCI 09.0024 X			
Coil Group	2.0 / 2.1			
Type of protection	Gas	II 2 G - Ex mb IIC T4/ T5		
	Dust	II 2 D - Ex tb IIIC - T130 / 95°C		
Degree of protection	IP67 according to IEC/EN 60529 standards			
Ambient temperature	-40°C to +65°C / 40°C The application is limited also by the temperature range of the valve.			
Insulation Class	F 155°C			
Electrical connection	Cable connection (3 x 1.5 mm ²) with cable gland M20 x 1.5, external earth screw connection.			
Elect. Power	DC	Pn (hot)	8 W	
		P (cold) 20°C	10 W	
	AC	Pn (holding)	9 W	
		Attraction cold	11 W	
Weight	500 g			
Voltages "Un" -10% to +10% of the Un	VAC/Hz	Code	VDC	Code
	24/50-60	P0	24	C2
	110/50-60	P2	48	C4
	220/50-60	R5	110	C5
	230/50-60	P9		
	240/50-60	Q1		

To Order a Coil choose Coil Ref + Voltage Code, example: 492070 for 24 VDC = 492070C2

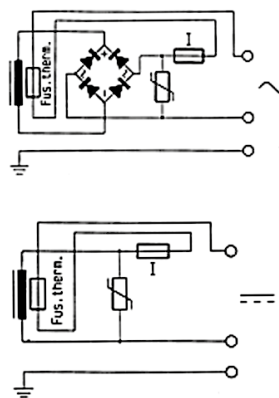
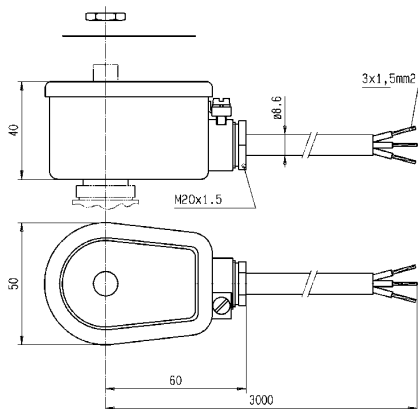

Coil Range

COIL GROUP

2.0/2.1

EXPLOSION PROOF ELECTRICAL PARTS



INCREASED SAFETY AND ENCAPSULATED ELECTRICAL PARTS "eb mb"

ZONE 1/21

492190 - ELECTRICAL PARTS 50 mm

This coil can be mounted with every Parker ATEX solenoid valves corresponding to the specified Coil Group.

See column "Coil Group" within valve pages.

Application: Control of solenoid valves in dangerous areas where explosion-proof protection Ex eb mb IIC T3 to T4 is required.

Benefits: Rotatable 360°, fiberglass -reinforced plastic housing. Solenoid coil, rectifier (silicium diodes), fuses and varistor protection are completely encapsulated into the coil housing by epoxy resin for shock and corrosion protection. Small size for ease of mounting in confined space.



Reference	492190			
Certificate	LCIE 02 ATEX 6023 X - IECEx LCI 06.0011 X			
Coil Group	2.0 / 2.1			
Type of protection	Gas	II 2 G - Ex eb mb IIC T3 / T4		
	Dust	II 2 D - Ex tb IIC - 195°C / 130°C		
Degree of protection	IP66 according to IEC/EN 60529 Standards			
Ambient temperature	-40°C to +75°C / +40°C The operating temperature of the valve/coil can be limited by that of the valve			
Insulation Class	F 155°C			
Electrical connection	Connection box with terminals and cable entry via gland M20 x 1.5 Possibility for additional earth via external screw			
Electrical consumption	DC	Pn (hot)	9 W	
		P (cold) 20°C	11 W	
	AC	Pn (holding)	11 W	
		Attraction cold	13 W	
Weight	320 g			
Voltages "Un"	VAC/Hz	Code	VDC	Code
-10% to +10% of the Un	24/50-60	P0	24	C2
	110/50-60	P2	48	C4
	230/50-60	P9	110	C5

To Order a Coil choose Coil Ref + Voltage Code, example: 492190 for 24 VDC = 492190C2

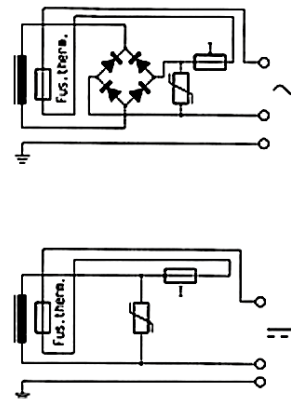
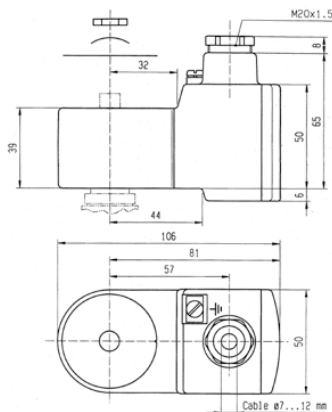

Coil Range

COIL GROUP

10.1

EXPLOSION PROOF ELECTRICAL PARTS



INCREASED SAFETY AND ENCAPSULATED ELECTRICAL PARTS "eb mb"

ZONE 1/21

492310 - ELECTRICAL PARTS 50 mm

This coil can be mounted with every Parker ATEX solenoid valves corresponding to the specified Coil Group.

See column "Coil Group" within valve pages.

Application: Control of solenoid valves in dangerous areas where explosion-proof protection Ex eb mb II T4 to T5 is required.

Benefits: Rotatable 360° fibreglass-reinforced plastic housing. Solenoid coil, rectifier (silicium diodes), fuses and varistor protection are completely encapsulated into the coil housing by epoxy resin for shock and corrosion protection. Small size for ease of mounting in confined space.



Reference	492310			
Certificate	LCIE 02 ATEX 6023 X - IECEx LCI 06.0011 X			
Coil group	10.1			
Type of protection	Gas	II 2 G - Ex eb mb II T4 / T5		
	Dust	II 2 D - Ex tb IIIC - T130°C / T95°C		
Degree of protection	IP66 according to IEC/EN 60529 Standards			
Ambiant temperature	-40°C to +75°C / to +40°C The operating temperature of the valve/coil can be limited by that of the valve			
Class of insulation	F 155°C			
Electrical connection	Connection box with terminals and cable entry via gland M20 x 1.5 - Possibility for additional earth via external screw.			
Elect. Power	DC	Pn (hot)	6 W	
		P (cold) 20°C	7.5 W	
	AC	Pn (holding)	6 W	
		Attraction cold	7.5 W	
Weight	500 g			
Voltages "Un" -10% to +10% of the Un	VAC/Hz	Code	VDC	Code
	24/50-60	P0	24	C2
	48/50-60	S4	48	C4
	230/50-60	P9	110	C5

To Order a Coil choose Coil Ref + Voltage Code, example: 492310 for 24 VDC = 492310C2

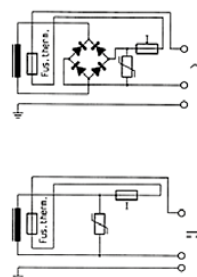
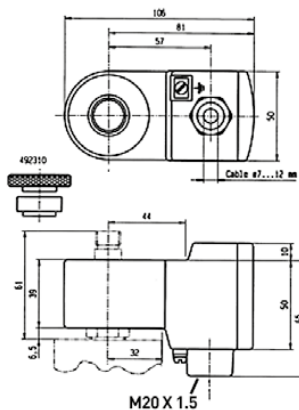

Coil Range

ZONE 1/21

COIL GROUP
10.3

EXPLOSION PROOF ELECTRICAL PARTS
FLAMEPROOF
ELECTRICAL PARTS "db"



497105 & 497105.02 - ELECTRICAL PARTS

These coils can be mounted with every Parker ATEX solenoid valves corresponding to the specified Coil Group. See column "Coil Group" within valve pages.

Application: Control of solenoid valves in dangerous areas where explosion-proof protection Ex db IIC T4 / T5 / T6 is required.

Benefits: Rotatable 360°, stainless steel with internal and external screw terminals for earth connection. Small size for ease of mounting in confined space. Simplifies conversion of existing equipment to hazardous area requirements.



Reference	497105 (M20x1.5) 49710502 (NPT 1/2")			
Certificate	INERIS 12ATEX0041X - IECEx IINE 12.0034X			
Coil Group	10.3			
Type of protection	Gas	II 2 G - Ex db IIC T4 / T5 / T6		
	Dust	II 2 D - Ex tb IIIC - 130°C / 95°C / 80°C		
Degree of protection	IP66 (with relevant cable gland) according to IEC/EN 60529 Standards			
Ambient temperature	-50°C to +80°C / +60°C / +40°C The operating temperature of the valve/coil can be limited by that of the valve			
Insulation Class	H 180°C			
Electrical connection	Electric connection is done in the connection chamber on an easily accessible connector terminals. The cable entry to the connection chamber is made through a 1/2" NPT or M20x1.5 thread in which an approved Exdb IIC cable gland must be installed.			
Electrical consumption	DC	Pn (hot)	8 W	
		P (cold) 20°C	9 W	
	AC	Pn (holding)	8 W	
		Attraction cold	9 W	
Voltage Tolerance	+/- 10% of nominal voltage			
Emerging Cuty	ED 100%			
Voltages	VAC/Hz	Code	VDC	Code
	24/50-60	P0	12	C1
	110-115 / 50-60	1P	24	C2
	220-230 / 50-60	3P	48 110	C4 C5

To Order a Coil choose Coil Ref + Voltage Code, example: 497105 for 24 VDC = 497105C2

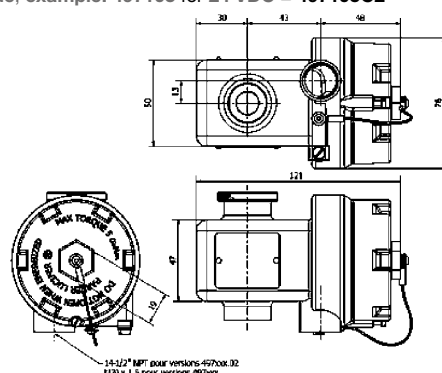

Coil Range

COIL GROUP

1.1

EXPLOSION PROOF ELECTRICAL PARTS

ENCAPSULATED ELECTRICAL PARTS "mb"



ZONE 1/21

ELECTRICAL PART LOW POWER 22 mm

These coils can be mounted with every Parker ATEX solenoid valves corresponding to the specified Coil Group.

See column "Coil Group" within valve pages.

Application:

Control of solenoid valves in dangerous areas where explosion-proof protection Ex mb IIC T4 / T5 is required.

Benefits:

Coil and magnetic circuit encapsulated in synthetic material - offering shock and corrosion protection. AC coils with integrated thermal fuse. Small size for ease of mounting in confined spaces.



Reference	482605		482606 or 482606.160*				
Certificate	LCIE 02 ATEX 6014 X - IECEx LCI 07.0026 X						
Coil Group	1.1						
Type of protection	Gas	II 2 G - Ex mb IIC T4 / T5					
	Dust	II 2 D - Ex tb IIIC - T130°C / 95°C					
Degree of protection	IP65 (with plug) according to IEC/EN 60529 Standards						
Ambiant temperature	-40°C to +65°C / +40°C			-40°C to +65°C / +35°C			
						The application is limited also by the temperature range of the valve.	
Insulation Class	F 155°C						
Electrical connection	Cable connection (3 x 0.75 mm ²) encapsulated with coil, cable material according to application						
Elect. Power	DC	Pn (hot)	5 W	2.5 W			
		P (cold) 20°C	6.5 W	3 W			
	AC	Pn (holding)	4 W	2 W			
		Attraction cold	8.9 VA (5 W)	5.7 VA (2.5 W)			
Weight	150 g						
Voltages "Un"	-10% to +10% of the Un	VDC	Code	VAC/Hz	Code	VDC	Code
		12	C1	24/50	A2	24	C2
		24	C2	48/50	A4	48	C4
				110/50-115/50	0A	110	C5
				220/50-230/50	3D		

To Order a Coil choose Coil Ref + Voltage Code, example: 482605 for 24 VDC = **482605C2**

* 482606.160 - 6 m cable length - available only in C2 and 3D

* 482606 - 1.5 m cable length

Fuses:

Both electrical parts 482605 & 482606 have to be connected in series with a safety fuse according to CEI 60127-3. Indicating example below:

482605:

DC: 12 V, 1000 mA - 24 V, 500 mA - 48 V, 200 mA - 110 V, 100 mA
 AC 50 Hz: 24 V, 500 mA - 48 V, 250 mA - 110/115 V, 100 mA - 220/230 V, 3 mA
 AC 60 Hz: 24 V, 630 mA - 110/115 V, 125 mA - 220/230 V, 63 mA

482606:

DC: 12 V, 400 mA - 24 V, 200 mA - 48 V, 100 mA - 110 V, 50 mA
 AC 50 Hz: 24 V, 250 mA - 48 V, 125 mA - 110/115 V, 63 mA - 220/230 V, 32 mA
 AC 60 Hz: 24 V, 315 mA - 110/115 V, 63 mA - 220/230 V, 32 mA

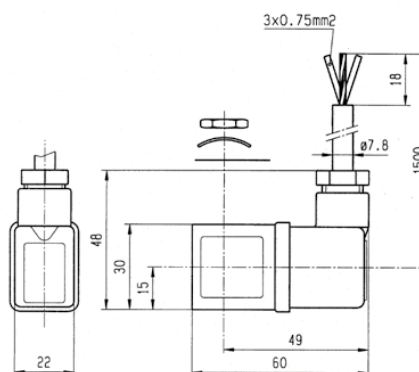

Coil Range

ZONE 0/20

COIL GROUP
7.0

EXPLOSION PROOF ELECTRICAL PARTS
INTRINSICALLY SAFE ELECTRICAL PARTS "ia"



483580 - 483960 ELECTRICAL PARTS 32 mm "IS"

These coils can be mounted with every Parker ATEX solenoid valves corresponding to the specified Coil Group.
See column "Coil Group" within valve pages.

Application: Control of solenoid valves in dangerous areas where explosion-proof protection Ex ia IIC T6 is required.

Benefits: Fully encapsulated assembly comprising a coil, metal armature, three diodes circuit and DIN plug connection.
The encapsulation provides an effective compact housing offering full protection against dust, oil, water, etc. Small size for ease of mounting in confined space. Available only in 28 VDC (suffix code : N7)



Reference (without plug) (with plug)	48358001 48396001	
Certificate	LCIE 02 ATEX 6065 X - IECEx LCI 07.0025 X	
Coil Group	7.0	
Type of protection	Gas: II 1 G - Ex ia IIC - T6 Dust: II 1 D - Ex ta IIC - T80°C	
Degree of protection	IP65 with plug according to IEC/EN 60529 Standards	
Ambiant temperature	- 40°C à + 55°C The operating temperature of the valve/coil can be limited by that of the valve.	
Electrical connection	The coil is connected with a 2P + E plug according to EN 175301-803 type A Contact 1 is marked as the positive pole ⊕.	
Maximum supply voltage	28 VDC (N7) - 110 mA The minimum operating voltage at maximum 60°C is 14 VDC.	
Power	DC Minimum	500 mW
	DC Maximum	3 W
		Depending on applied voltage, IS barrier type and resistance of connected cable
Coil resistance at 20°C	340 Ω	
Impedance	340 Ω	
Apparent inductance	0 mH	
Apparent capacitance	0 μF	
Weight	160 g (with plug)	

To Order a Coil choose Coil Ref + Voltage Code, example: 483580 for 28 VDC = **483580N7**

These coils must be used with suitable housings, see example below:

The coil assembly kit **Ref. 2995** corresponds to the "housing" of Lucifer® valve numbering system (Valve - housing - coil/voltage). It is composed of a nameplate giving details of the valve type, a round washer and a nut to ensure the fixing between 32 mm coil and the valve.

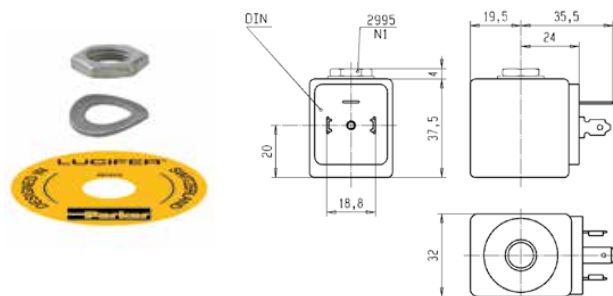

Important

The intrinsically safe supply circuit should have enough capacity in all environmental conditions to assure a **minimum operating current of 35 mA** through the coil.

The minimal holding current is 20 mA.

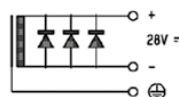

For the barrier compatibility see the corresponding table in in appendix section.

These coil must be used with suitable housing : **Ref. 2995**



Coil Range

COIL GROUP

8.0

EXPLOSION PROOF ELECTRICAL PARTS



INTRINSICALLY SAFE
ELECTRICAL PARTS "ia"

ZONE 0/20

495910 - MINIWATT - 0.3 W ELECTRICAL PARTS "IS" "BOOSTER" 37 mm

These coils can be mounted with every Parker ATEX solenoid valves corresponding to the specified Coil Group.

See column "Coil Group" within valve pages.

Application: Control of solenoid valves in dangerous areas where explosion-proof protection Ex ia IIC T4 to T6 is required.

Benefits: Rotatable 360° fibreglass-reinforced plastic housing (class H). Solenoid coil, rectifier (silicium diodes), fuses and varistor protection are completely encapsulated into the coil housing by epoxy resin for shock and corrosion protection. Small size for ease of mounting in confined space. Available only in 28 VDC (code: N7).



Reference	495910	
Certificate	LCIE 03 ATEX 6464 X - IECEx LCI 07.0006 X	
Coil Group	8.0	
Type of protection	Gas	II 1 G - Ex ia IIC - T4 / T5 / T6
	Dust	II 1 D - Ex ta IIIC T80 / 95 / 130°C
Degree of protection	IP67 according to IEC/EN 60529 Standards	
Ambiant temperature	- 40°C to +80°C / 75°C / 65°C The application is limited also by the temperature range of the valve..	
Class of insulation	H 180°C	
Electrical connection	Electric connection is done in the connection box on an easily accessible connector terminals. The introduction of the cable (Ø min 7 mm, Ømax. 11 mm, section max. 2.5 mm ²) in the connection box passes by the built in M20 x 1.5 cable gland	
Maximum supply voltage	28 VDC (N7) - 110 mA	
Power	DC	Minimum
		Maximum
		0.3 W (with 13 VDC)
		1.2 W (with 24 VDC)
Depending on applied voltage, IS barrier type and resistance of connected cable		
Line check	4 mA or 5 VDC max	
Coil resistance at 20°C	Charge ~ 550 Ω - Holding ~ 500 Ω	
Impedance	0 mH	
Apparent inductance	0 µF	
Apparent capacitance		
Response time	2 - 3 s	
Weight	500 g	

To Order a Coil choose Coil Ref + Voltage Code, example: 495910 for 28 VDC = **495910N7**

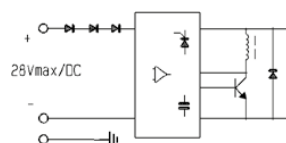
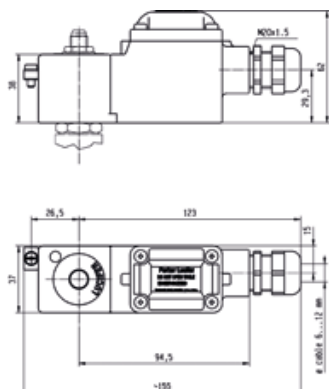

Coil Range

ZONE 0/20

COIL GROUP
9.0

EXPLOSION PROOF ELECTRICAL PARTS
INTRINSICALLY SAFE
ELECTRICAL PARTS "ia"



496565 ELECTRICAL PARTS "BOOSTER" "IS" 37 mm

This coil can be mounted with every Parker ATEX solenoid valves corresponding to the specified Coil Group. See column "Coil Group" within valve pages.

Application: Control of solenoid valves in dangerous areas where explosion-proof protection Ex ia IIC T4 to T6 is required.

Benefits: Rotatable 360° fibreglass-reinforced plastic housing (class H). Solenoid coil, rectifier (silicium diodes), fuses and varistor protection are completely encapsulated into the coil housing by epoxy resin for shock and corrosion protection. The plastic housing is delivered with M20 x 1.5 cable gland. Small size for ease of mounting in confined space. Available only in 28 VDC (code: N7).



Reference	496565	
Certificate	LCIE 08 ATEX 6071 X - IECEx LCI 08.0030 X	
Coil group	9.0	
Type of protection	Gas	II 1 G - Ex ia IIC - T4 / T5 / T6
	Dust	II 1 D - Ex ta IIIC - T80 / T95 / T130°C
Degree of protection	IP67 according to IEC/EN 60529 Standards	
Ambiant temperature	- 40°C to +80 / 75 / 65°C The application might also be limited by the temperature range of the valve.	
Electrical connection	Cable connection through a plastic cable gland M20 x 1.5 allowing use of cable diameter from 7 to 12 mm. Additional earth connection possible with external screw terminal.	
Class of insulation	H180°C	
Minimum Courant of function	20 mA	
Minimum voltage of function at 60°C	28 VDC (N7)	
Safety parameters	28 V / 110 mA / 0.77 W	28 V / 280 mA / 1.96 W
Maximum acceptable values:	27 V / 120 mA / 0.81 W	27 V / 320 mA / 2.16 W
Ui (V) / Ii (mA) / Pi (W)	26 V / 135 mA / 0.88 W	26 V / 350 mA / 2.27 W
	25 V / 150 mA / 0.94 W	25 V / 390 mA / 2.43 W
	24 V / 170 mA / 1.02 W	24 V / 430 mA / 2.58 W
Line check	4 mA or 5 VDC max	
Apparent Impedance Typ.	Attraction ~ 600 Ω - Holding ~ 570 Ω	
Apparent Inductance	0 mH	
Apparent Capacitance	0 μF	
Response Time Typ.	2 - 4 s	
Weight	500 g	

To Order a Coil choose Coil Ref + Voltage Code, example: 496565 for 28 VDC = **496565N7**

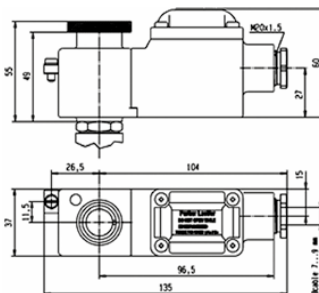

Housing

COIL GROUP

4538

WATERPROOF AND DUSTPROOF HOUSING

Waterproof housing:

Reference:	4538
Material:	Epoxy varnished steel
Degree of protection:	IP according to IEC/EN 60529 IP 67 with cable gland
Electrical connection:	Cable connection by cable gland M20x1.5 according to DIN 46320. Cable with outer diameter 6.5 - 13.5 mm can be simply sealed using a rubber gland with resilient sealing rings. The enclosure is internally and externally fitted with grounding and earthing screw terminals.
Weight:	180 g



Benefits:

This enclosure is dust- and waterproof. It corresponds to the degree of "International Protection" IP 67 according to IEC / EN 60529. Corrosion resistant, the metal housing offers good protection for the coil against shocks and other outside influences - rotatable 360° - easy mounting in confined spaces - easy access to the screw terminals - single-nut mounting - light weight - simple conversion of existing electrical equipment to other requirements without interruption of fluid passage in the valve.

Application:

This housing can be equipped with several coils of our range, like the standard, high temperature, double-frequency and magnetic latch coils.

Compatible coils:

- **481000 - Standard Coil**
8 W Class F (155°C)
- **483520 - Double-Frequency Coil**
9 W Class F (155°C)
- **486265 - High Temperature & High Power**
14 W Class H (180°C)

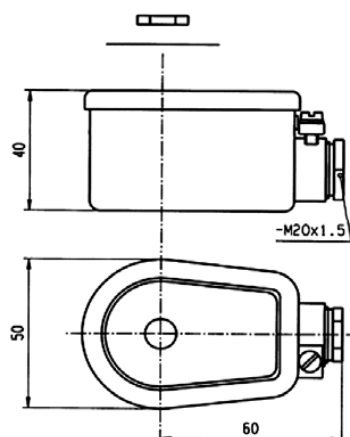



Parker's Motion & Control Technologies

At Parker, we're guided by a relentless drive to help our customers become more productive and achieve higher levels of profitability by engineering the best systems for their requirements. It means looking at customer applications from many angles to find new ways to create value. Whatever the motion and control technology need, Parker has the experience, breadth of product and global reach to consistently deliver. No company knows more about motion and control technology than Parker. For further info call 00800 27 27 5374



Aerospace

Key Markets

- Aftermarket services
- Commercial transports
- Engines
- General & business aviation
- Helicopters
- Launch vehicles
- Military aircraft
- Missiles
- Power generation
- Regional transports
- Unmanned aerial vehicles

Key Products

- Control systems & actuation products
- Engine systems & components
- Fluid conveyance systems & components
- Fluid metering, delivery & atomization devices
- Fuel systems & components
- Fuel tank inerting systems
- Hydraulic systems & components
- Thermal management
- Wheels & brakes



Climate Control

Key Markets

- Agriculture
- Air conditioning
- Construction Machinery
- Food & beverage
- Industrial machinery
- Life sciences
- Oil & gas
- Precision cooling
- Process
- Refrigeration
- Transportation

Key Products

- Accumulators
- Advanced actuators
- CO₂ controls
- Electronic controllers
- Filter driers
- Hand shut-off valves
- Heat exchangers
- Hose & fittings
- Pressure regulating valves
- Refrigerant distributors
- Safety relief valves
- Smart pumps
- Solenoid valves
- Thermostatic expansion valves



Electromechanical

Key Markets

- Aerospace
- Factory automation
- Life science & medical
- Machine tools
- Packaging machinery
- Paper machinery
- Plastics machinery & converting
- Primary metals
- Semiconductor & electronics
- Textile
- Wire & cable

Key Products

- AC/DC drives & systems
- Electric actuators, gantry robots & slides
- Electrohydraulic actuation systems
- Electromechanical actuation systems
- Human machine interface
- Linear motors
- Stepper motors, servo motors, drives & controls
- Structural extrusions



Filtration

Key Markets

- Aerospace
- Food & beverage
- Industrial plant & equipment
- Life sciences
- Marine
- Mobile equipment
- Oil & gas
- Power generation & renewable energy
- Process
- Transportation
- Water Purification

Key Products

- Analytical gas generators
- Compressed air filters & dryers
- Engine air, coolant, fuel & oil filtration systems
- Fluid condition monitoring systems
- Hydraulic & lubrication filters
- Hydrogen, nitrogen & zero air generators
- Instrumentation filters
- Membrane & fiber filters
- Microfiltration
- Sterile air filtration
- Water desalination & purification filters & system



Fluid & Gas Handling

Key Markets

- Aerial lift
- Agriculture
- Bulk chemical handling
- Construction machinery
- Food & beverage
- Fuel & gas delivery
- Industrial machinery
- Life sciences
- Marine
- Mining
- Mobile
- Oil & gas
- Renewable energy
- Transportation

Key Products

- Check valves
- Connectors for low pressure fluid conveyance
- Deep sea umbilicals
- Diagnostic equipment
- Hose couplings
- Industrial hose
- Mooring systems & power cables
- PTFE hose & tubing
- Quick couplings
- Rubber & thermoplastic hose
- Tube fittings & adapters
- Tubing & plastic fittings



Hydraulics

Key Markets

- Aerial lift
- Agriculture
- Alternative energy
- Construction machinery
- Forestry
- Industrial machinery
- Machine tools
- Marine
- Material handling
- Mining
- Oil & gas
- Power generation
- Refuse vehicles
- Renewable energy
- Truck hydraulics
- Turf equipment

Key Products

- Accumulators
- Cartridge valves
- Electrohydraulic actuators
- Human machine interfaces
- Hybrid drives
- Hydraulic cylinders
- Hydraulic motors & pumps
- Hydraulic systems
- Hydraulic valves & controls
- Hydrostatic steering
- Integrated hydraulic circuits
- Power take-offs
- Power units
- Rotary actuators
- Sensors



Pneumatics

Key Markets

- Aerospace
- Conveyor & material handling
- Factory automation
- Life science & medical
- Machine tools
- Packaging machinery
- Transportation & automotive

Key Products

- Air preparation
- Brass fittings & valves
- Manifolds
- Pneumatic accessories
- Pneumatic actuators & grippers
- Pneumatic valves & controls
- Quick disconnects
- Rotary actuators
- Rubber & thermoplastic hose & couplings
- Structural extrusions
- Thermoplastic tubing & fittings
- Vacuum generators, cups & sensors



Process Control

Key Markets

- Alternative fuels
- Biopharmaceuticals
- Chemical & refining
- Food & beverage
- Marine & shipbuilding
- Medical & dental
- Microelectronics
- Nuclear Power
- Offshore oil exploration
- Oil & gas
- Pharmaceuticals
- Power generation
- Pulp & paper
- Steel
- Water/wastewater

Key Products

- Analytical Instruments
- Analytical sample conditioning products & systems
- Chemical injection fittings & valves
- Fluoropolymer chemical delivery fittings, valves & pumps
- High purity gas delivery fittings, valves, regulators & digital flow controllers
- Industrial mass flow meters/controllers
- Permanent no-weld tube fittings
- Precision industrial regulators & flow controllers
- Process control double block & bleed
- Process control fittings, valves, regulators & manifold valves



Sealing & Shielding

Key Markets

- Aerospace
- Chemical processing
- Consumer
- Fluid power
- General industrial
- Information technology
- Life sciences
- Microelectronics
- Military
- Oil & gas
- Power generation
- Renewable energy
- Telecommunications
- Transportation

Key Products

- Dynamic seals
- Elastomeric o-rings
- Electro-medical instrument design & assembly
- EMI shielding
- Extruded & precision-cut, fabricated elastomeric seals
- High temperature metal seals
- Homogeneous & inserted elastomeric shapes
- Medical device fabrication & assembly
- Metal & plastic retained composite seals
- Shielded optical windows
- Silicone tubing & extrusions
- Thermal management
- Vibration dampening

ENGINEERING YOUR SUCCESS.



Parker Worldwide

AE – UAE, Dubai
Tel: +971 4 8127100
parker.me@parker.com

AR – Argentina, Buenos Aires
Tel: +54 3327 44 4129

AT – Austria, Wiener Neustadt
Tel: +43 (0)2622 23501-0
parker.austria@parker.com

AT – Eastern Europe,
Wiener Neustadt
Tel: +43 (0)2622 23501 900
parker.easteurope@parker.com

AU – Australia, Castle Hill
Tel: +61 (0)2-9634 7777

AZ – Azerbaijan, Baku
Tel: +994 50 2233 458
parker.azerbaijan@parker.com

BE/LU – Belgium, Nivelles
Tel: +32 (0)67 280 900
parker.belgium@parker.com

BR – Brazil, Cachoeirinha RS
Tel: +55 51 3470 9144

BY – Belarus, Minsk
Tel: +375 17 209 9399
parker.belarus@parker.com

CA – Canada, Milton, Ontario
Tel: +1 905 693 3000

CH – Switzerland, Etoy
Tel: +41 (0)21 821 87 00
parker.switzerland@parker.com

CL – Chile, Santiago
Tel: +56 2 623 1216

CN – China, Shanghai
Tel: +86 21 2899 5000

CZ – Czech Republic, Klecany
Tel: +420 284 083 111
parker.czechrepublic@parker.com

DE – Germany, Kaarst
Tel: +49 (0)2131 4016 0
parker.germany@parker.com

DK – Denmark, Ballerup
Tel: +45 43 56 04 00
parker.denmark@parker.com

ES – Spain, Madrid
Tel: +34 902 330 001
parker.spain@parker.com

FI – Finland, Vantaa
Tel: +358 (0)20 753 2500
parker.finland@parker.com

FR – France, Contamine s/Arve
Tel: +33 (0)4 50 25 80 25
parker.france@parker.com

GR – Greece, Athens
Tel: +30 210 933 6450
parker.greece@parker.com

HK – Hong Kong
Tel: +852 2428 8008

HU – Hungary, Budapest
Tel: +36 1 220 4155
parker.hungary@parker.com

IE – Ireland, Dublin
Tel: +353 (0)1 466 6370
parker.ireland@parker.com

IN – India, Mumbai
Tel: +91 22 6513 7081-85

IT – Italy, Corsico (MI)
Tel: +39 02 45 19 21
parker.italy@parker.com

JP – Japan, Tokyo
Tel: +81 (0)3 6408 3901

KR – South Korea, Seoul
Tel: +82 2 559 0400

KZ – Kazakhstan, Almaty
Tel: +7 7272 505 800
parker.easteurope@parker.com

MX – Mexico, Apodaca
Tel: +52 81 8156 6000

MY – Malaysia, Shah Alam
Tel: +60 3 7849 0800

NL – The Netherlands,
Oldenzaal
Tel: +31 (0)541 585 000
parker.nl@parker.com

NO – Norway, Asker
Tel: +47 66 75 34 00
parker.norway@parker.com

NZ – New Zealand, Mt Wellington
Tel: +64 9 574 1744

PL – Poland, Warsaw
Tel: +48 (0)22 573 24 00
parker.poland@parker.com

PT – Portugal, Leca da Palmeira
Tel: +351 22 999 7360
parker.portugal@parker.com

RO – Romania, Bucharest
Tel: +40 21 252 1382
parker.romania@parker.com

RU – Russia, Moscow
Tel: +7 495 645-2156
parker.russia@parker.com

SE – Sweden, Spånga
Tel: +46 (0)8 59 79 50 00
parker.sweden@parker.com

SG – Singapore
Tel: +65 6887 6300

SK – Slovakia, Banská Bystrica
Tel: +421 484 162 252
parker.slovakia@parker.com

SL – Slovenia, Novo Mesto
Tel: +386 7 337 6650
parker.slovenia@parker.com

TH – Thailand, Bangkok
Tel: +662 717 8140

TR – Turkey, Istanbul
Tel: +90 216 4997081
parker.turkey@parker.com

TW – Taiwan, Taipei
Tel: +886 2 2298 8987

UA – Ukraine, Kiev
Tel: +380 44 494 2731
parker.ukraine@parker.com

UK – United Kingdom,
Warwick
Tel: +44 (0)1926 317 878
parker.uk@parker.com

US – USA, Cleveland
Tel: +1 216 896 3000

VE – Venezuela, Caracas
Tel: +58 212 238 5422

ZA – South Africa,
Kempton Park
Tel: +27 (0)11 961 0700
parker.southafrica@parker.com

Ed.: 2016-04

European Product Information Centre

Free phone: 00 800 27 27 5374
(from AT, BE, CH, CZ, DE, EE, ES, FI, FR, IE, IL, IS,
IT, LU, MT, NL, NO, PT, SE, SK, UK)

US Product Information Centre

Free phone: 1-800-27 27 537
www.parker.com

