

► Engineering Reference

Linear & Rotary Positioning Stages

Table of Contents

1. Linear Positioning Stages	269	2.2 Loading	
1.1 Precision		Axial Load	
Linear		Perpendicular Load	
Accuracy		3. Motion Control Components	275
Repeatability		3.1 Motors	
Resolution		Brushless Servo	
Straightness		Linear Servo	
Flatness		Piezo Ceramic	
Angular		3.2 Encoders	
Pitch		Rotary	
Yaw		Linear	
Roll		3.3 Controller/Amplifier	
Abbe Error		4. Positioning System Analysis	279
Dynamic		4.1 System Modeling	
Constant Velocity		Physical Model	
Settling Time		Schematic Diagram	
1.2 Loading		Block Diagram	
Dynamic Loading		Transfer Functions	
Moment Loading		System Variables & Parameters	
Maximum Axial Force		4.2 Frequency Response (Stability Analysis)	
1.3 Assembly		Components	
Configurations		Controller - PID	
Single Axis		Servo Amplifier	
Compound XY		Motor / Stage	
Compound XYZ		Structure	
Split XYZ		Complete System	
Gantry		Closed Loop Bandwidth	
Stage Components		Gain Margin	
Bearing		Phase Margin	
Motor / Actuator		4.3 Simulation (System Design)	
Encoder		Kinematics	
2. Rotary Positioning Stages	274	Dynamics & Settling	
2.1 Precision		Linear Motor & Amplifier Sizing	
Axial Runout		3-D Precision Analysis	
Radial Runout		Glossary	288
Backlash			
Wobble			

1. Linear Positioning Stages

1.1 Precision

LINEAR

Accuracy - The difference between a commanded position and an actual position of a positioning stage. Accuracy is typically specified in microns that represent specified number of standard deviation "Sigma" (see definition below), per given travel, at a specified height above the stage mounting plate. For example: a

± 3 micron accuracy, 3 Sigma, per 500 mm travel means that if the controller commands the positioning stage to move to a location 500mm away from a known "home" position in space, then, in 99.8% of the times that this move will be made, the actual position of the stage, at 25mm above the mounting surface, will end up being between 499.997 and 500.003mm.

Repeatability - Repeatability represents the maximum deviation between actual position values, obtained in repetitive moves of a positioning stage, to a desired position. Repeatability, like accuracy, corresponds to a specified number of "Sigma", per specified travel, at a specified height above the mounting surface of the stage.

Resolution (Motion) - The smallest positioning movement that can be achieved by a positioning stage.

Resolution (Encoder) - The smallest increment of the position feedback signal that can be measured by a feedback device (e.g., encoder).

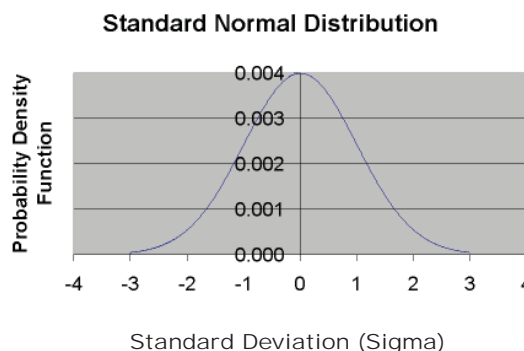

Standard Deviation ("sigma") - The average deviation of a Random Variable (a variable such as position error, whose outcome is of a statistical nature) from its average value ("mean"). The chart below represents a Standard Normal distribution of a random variable with zero mean and sigma of 1. The X Axis represents the random variable in units of "sigma", and the Y Axis represents the Probability Density function of the random variable. The density function is used to calculate the probability that the random variable will occur between two values on the X Axis. More specifically, the probability of a random variable occurring between two values on the X Axis equals to the area under the Probability Density Function between these two values. The total area under the curve equals 1. Some important areas are as follows: the area between ± 1 sigma is 0.68, between ± 2 sigma it is 0.954 and between ± 3 sigma it is 0.997. This means, for example, that the probability of a random variable occurring between ± 3 Sigma is 99.8%.

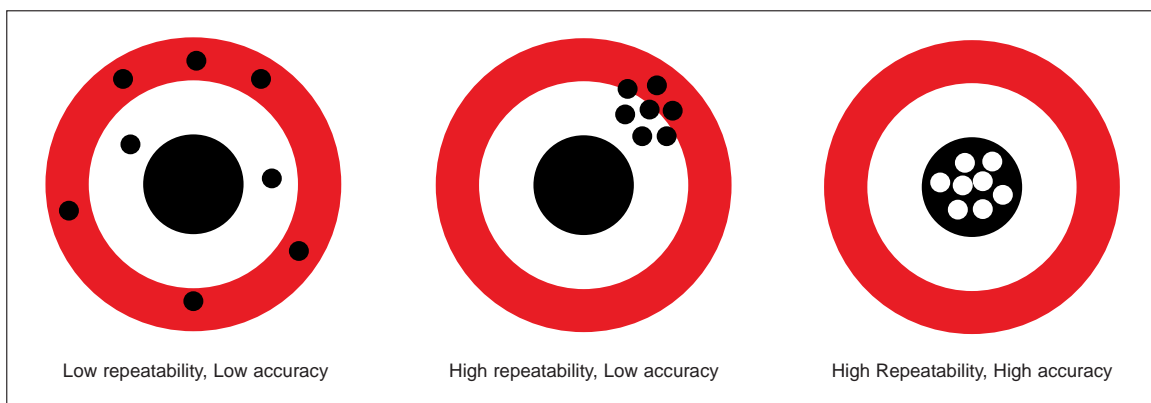

Engineering Reference

Linear & Rotary Positioning Stages

Flatness - The maximum boundaries of positioning path of motion projected on the vertical plane.

Straightness - The maximum boundaries of positioning path of motion projected on a horizontal plane.

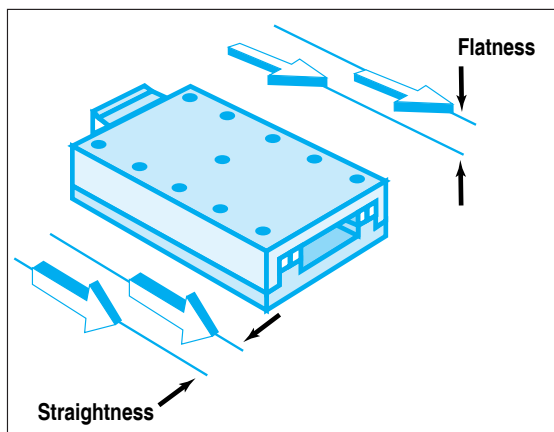

Abbe Error - A linear positioning error caused by a combination of an angular error in the bearing of the positioning stage, and an offset between the bearing and the actual point of interest. (See also 3-D Precision Analysis in Section 4.3.)

DYNAMIC

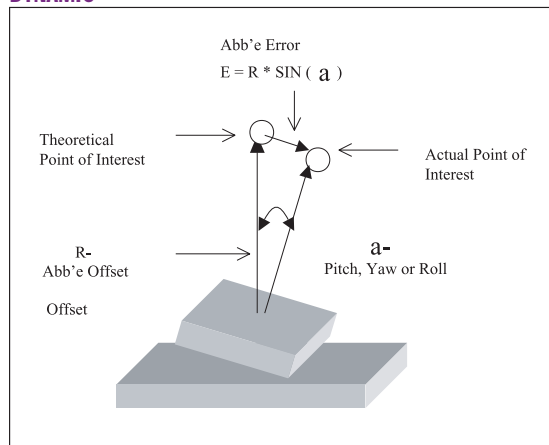

(See also Dynamics and Settling in section 4.3.)

ANGULAR

Pitch - An angular deviation possible in positioning systems, in which the table leading edge rises or falls as the table translates along the direction of travel. This represents rotation around a horizontal axis, perpendicular to the axis of travel.

Yaw - An angular deviation from ideal straight line motion, in which the positioning table rotates around the Z (vertical) Axis as it translates along its travel axis.

Roll - An angular deviation from ideal straight line motion, in which the positioning table rotates around its axis of travel as it translates along that axis.

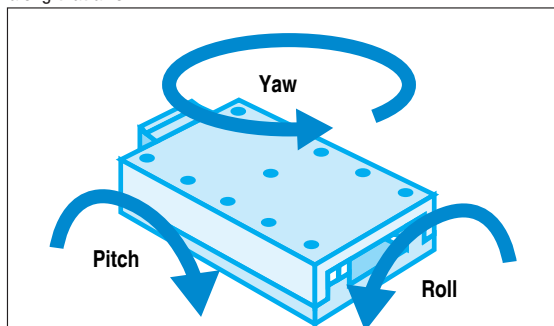

Constant Velocity - A measure of smoothness of motion of a positioning stage. Typically measured in percent variation from a nominal value at a given sampling interval. High smoothness of motion can be achieved by using crossed roller or air bearing stages with ironless linear motors.

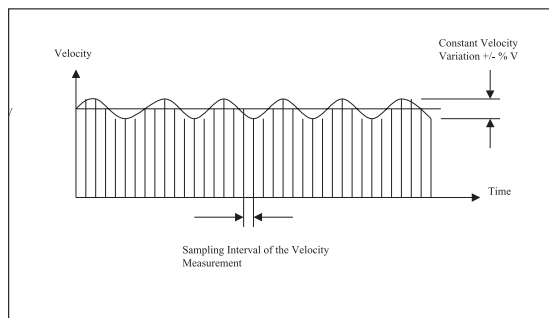

Settling time - The time required for a step response of a system parameter to stop oscillating or ringing and reach its final value. For example, the time it takes for a velocity profile to settle to a specified value of constant velocity after the acceleration ramp phase. Also, the time it takes for a displacement profile to settle to specified accuracy after the deceleration phase at the end of a positioning move. Settling time is greatly affected by the shock, jerk, structural damping and resonance frequencies. Improved settling time in positioning systems can be achieved by high structural stiffness, low moving mass, high natural frequency of the structure, structural damping, high closed loop band width at the overall positioning system and good servo tuning.

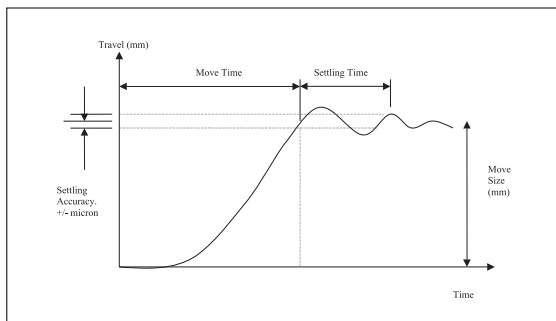
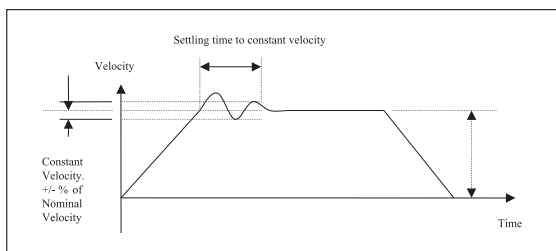

1.2 Loading

Dynamic Loading - Dynamic loading of a stage is the maximum load that may be applied for a bearing life of 254,000m (10 Million inches) of travel with no evidence of fatigue appearing in 90% of the bearing. This assumes that the load is constant in magnitude and direction and that all forces are perpendicular to the motion of the stage.

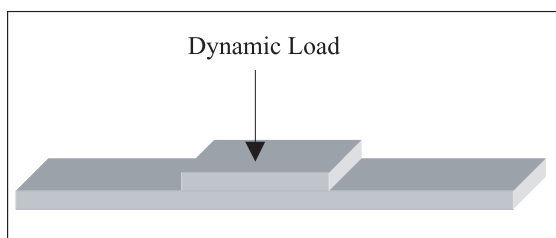

Moment Loading - A moment loading defines a twisting load about the bearings. The impact of a moment load is that it is not distributed about all of the bearings uniformly. A moment load can be created in a variety of orientations:

Mx - When a load is cantilevered off the end of an axis, parallel to the direction of travel

My - When the load is cantilevered off the sides of an axis, perpendicular to the direction of travel

Mz - When a force causes a rotational moment about the center of an axis.

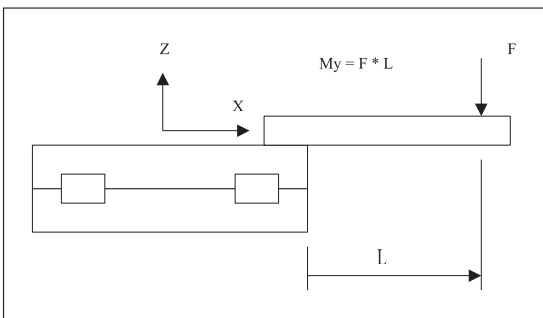
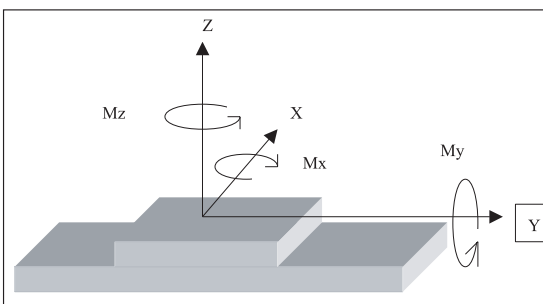

Maximum Axial Force - The maximum thrust force that the stage can generate in the direction of travel. This force is used to overcome friction, damping, tool resistance and acceleration.

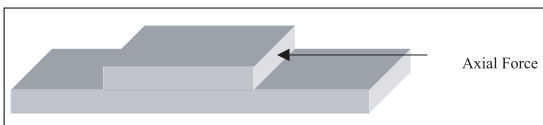

Linear & Rotary Positioning Stages

Engineering Reference

Linear & Rotary Positioning Stages

1.3 Assembly

CONFIGURATIONS

Single Axis - The simplest form of positioning stage. Sometimes referred to as "Table", "Slide", "Actuator" or "Stage". It typically consists of slide, base, bearing, motor, encoder, limits, home, cable carrier and hard stops. The base can be mounted to a rigid structure or to the slides of other stages in various configurations as shown below. The slide, which is the moving part, can be used to move another stage, or any object such as a tool, work, test and measuring devices.

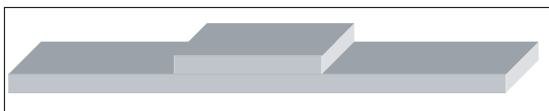

Compound XY - This configuration provides the simplest form of 2 linear degrees of freedom of a positioning system where the base of the top axis is bolted to the slide of the lower axis. For a high-performance positioning application, a "monolithic" design can be used where the base of the top axis and the slide of the bottom axis are rigidly made as a single part. In a compound XY configuration care should be given in consideration to the Abbe Error of the top axis due to cantilever "diving board" effect. (see sections 1.1 for the definition of Abbe Error, and 4.3 for 3D accuracy analysis.)

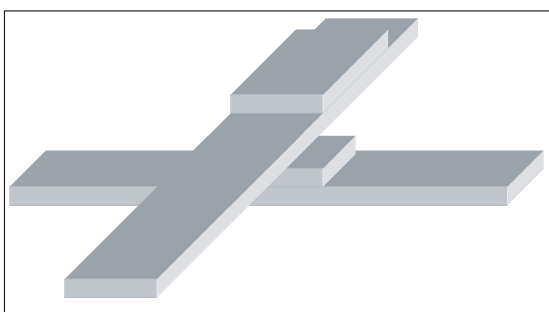

Compound XYZ - This configuration provides the simplest form of 3 linear degrees of freedom of a positioning system with the smallest footprint. In using this configuration care must be given to calculate the three dimensional accuracy. In particular the Abbe error. (Due to large offset between the bearing of the lowest stage and the point of interest at the top of the vertical stage.) (See sections 1.1 for the definition of Abbe Error, and 4.3 for 3 D accuracy analysis)

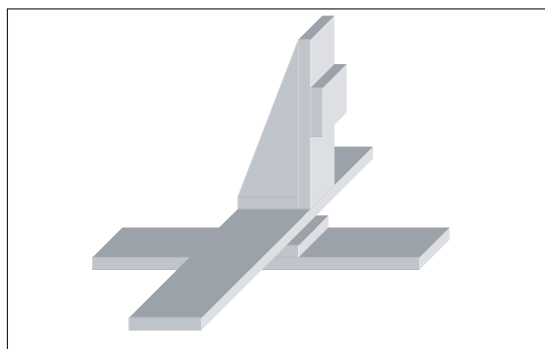

Split XYZ Axes - A split axes positioning stage typically provides higher precision and higher stiffness than a compound configuration of the same number of axes. The reason is that at least 2 axes are mounted to a flat, rigid, stationary base with a fewer number of stages that ride on other stages. The result is smaller Abbe Errors and less cantilever effects at the expense of a larger footprint. Note that although this structure looks similar to a Gantry configuration, as shown below, the Z Axis is rigidly mounted to a stationary bridge, and the X Axis is mounted to a stationary Base.

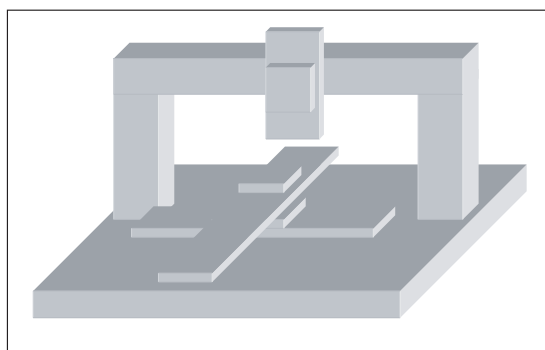

Gantry - This configuration has the best accessibility to the space around it per footprint of the machine. It is commonly used as single cell or in process application where several machines are operating over a conveyor. Gantry configuration, driven by linear motors and designed for high natural frequency (typically 150 Hz), can provide an excellent solution that combines high precision, high speed and low settling time. Gantry can further be classified according to the following options:

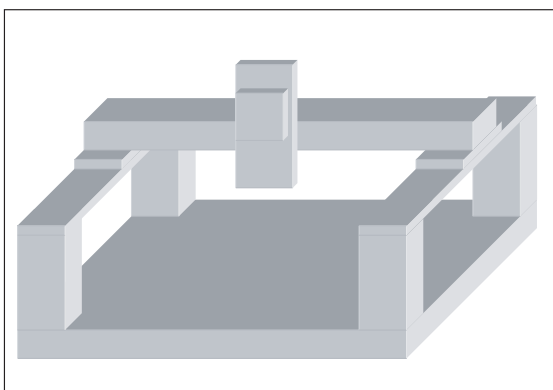

- ▶ Single-sided motor drive typically used for small-size applications
- ▶ Double-sided motor, driven together by a single amplifier with 1 sided encoder typically used in large system, with low accuracy requirements
- ▶ Double-sided motor, driven as two independent axes X1, X2 operating as master slave with two sided encoder typically used for large machines that require high precision. Flexure slides may be needed on the X Axes to prevent cleavage (motion resistance at the bearing of the X Axis due to skewed movement of the Y Axis.)

STAGE COMPONENTS

Bearings

Recirculation Bearing - Typically used for highest stiffness and high speed (Pitch, Yaw and Roll on the order of 10 arc sec).

Crossed Roller Bearing - Typically used for a combination of high stiffness and high smoothness of motion (Pitch, Yaw, Roll on the order of 5 arc sec).

Air Bearing - Typically used for highest precision (sub micron) and highest smoothness of motion. (Pitch, Yaw Roll on the order of 1 arc sec).

Motors - (See section 3.1 for more details.)

Rotary Motor / Gear Box / Ball Screw - Typically used for high acceleration, high force.

Rotary Motor / Gear Box / Lead Screw - Typically used for high smoothness of motion.

Linear Motor (Ironless) - Typically used for very high smoothness of motion at low or high velocity.

Linear Motor (Iron Core) - Typically used for achieving a combined high force (up to 20,000 N), long travel (unlimited) and high speed (up to 10 m / sec).

Piezo Ceramic Motor - Typically used for submicron positioning applications.

Lead Screw: A device for translating rotary motion into linear motion, consisting of an externally threaded screw and an internally threaded carriage (nut).

Ball Screw: A lead screw which has its threads formed as a ball bearing race; the carriage contains a circulating supply of balls for increased efficiency.

Encoders - (see section 3.2 for more details)

Rotary Encoder - Typically mounted to the back of a rotary motor and used for lower precision at lower cost.

Linear Encoder - Typically used for higher precision at higher cost.

Engineering Reference

Linear & Rotary Positioning Stages

2. Rotary Positioning Stages

2.1 Precision

Axial Runout Error - The total indicated reading (TIR) of axis movement along the axis of rotation

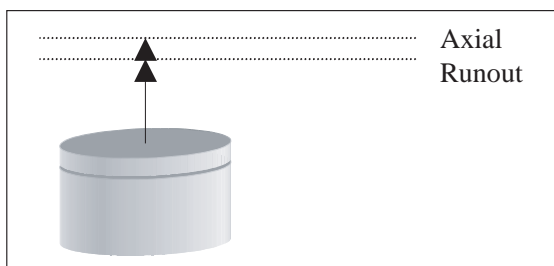

Radial Runout Error - The total indicated reading of the horizontal movement of the rotary table.

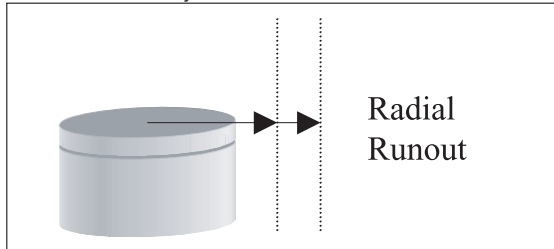

Backlash Error - The error in rotational position due to clearance between a worm and a gear as a result of changing direction of motion. Backlash has an effect on two directional repeatability since the motion of worm is lost while reversing direction and traveling through the gap it has with the gear.

Wobble Error - The angular error between the actual axis of rotation and the theoretical axis of rotation.

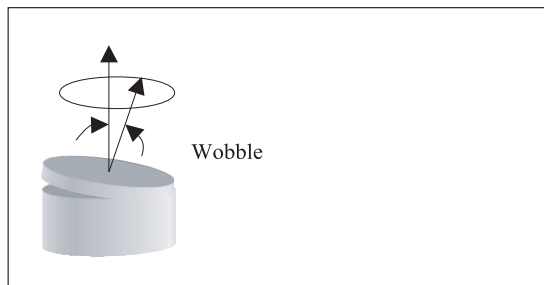

2.2 Loading

Axial Load Capacity - The maximum allowable force acting along the axis of rotation of the rotary stage.

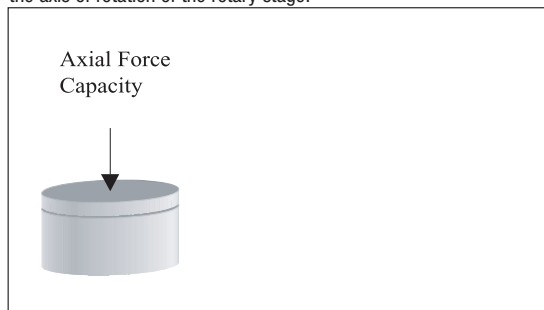

Perpendicular Load Capacity - The maximum load perpendicular to the positioning stage top surface, applied at a specified radius from the axis of rotation of the table.

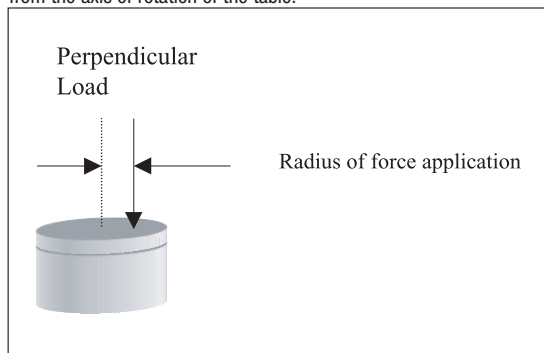

3. Motion Control Components

3.1 Motors

Brushless Rotary Motor & Brushless Direct Drive



Linear Motor

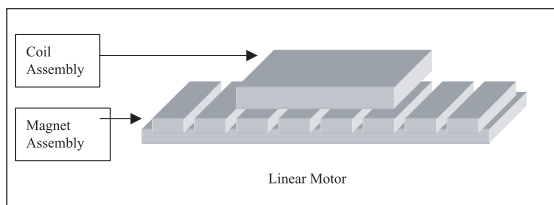

Piezo - Ceramic Motor

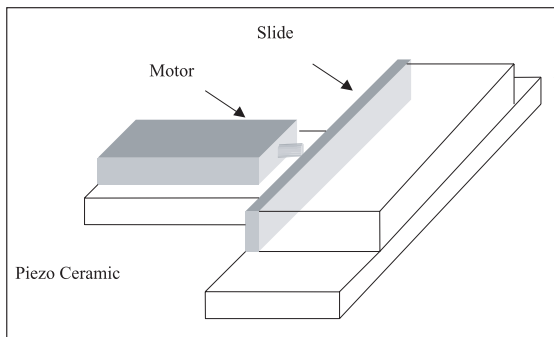

Various Types of Motors Used in Positioning Systems

Servomotor - A device that converts electrical current to mechanical energy where the current is varied by a servo amplifier in a closed loop control system.

DC Motor - A device that converts electrical direct current into mechanical energy. It requires a commutating device, either brushes or electronic. Usually requires source of DC power.

AC Motor - A device that converts electrical alternating current into mechanical energy. Requires no commutation devices such as brushes. Normally operated off commercial AC power. Can be single or multiple phase.

Synchronous Motor - Another term for a Brushless DC motor.

Permanent Magnet Motor - A motor utilizing permanent magnets to produce a magnetic field. Has linear torque / speed or force / speed characteristic.

Brushless Motor - A type of direct current motor that utilizes electronic commutation rather than brushless to transfer current.

Iron Core Linear Motor - A permanent magnet motor consisting of laminated ferrous coil assembly and a single-sided secondary magnet assembly.

Ironless Linear Motor - A permanent magnet motor consisting of a non laminated coil assembly and a u-channel secondary magnet assembly

Piezo Ceramic Motor - A motor made of a small ceramic plate, oscillating at high frequency (e.g. 40Khz), causing its tip to form circular motion. As the tip comes in contact with a longer ceramic plate, attached to the slide of a positioning stage, it applies friction forces on the plate and causes it to move in the direction of the tip circular rotation.

Linear & Rotary Positioning Stages

Engineering Reference

Linear & Rotary Positioning Stages

3.2 Encoders

The encoder motion component as shown below is a position feedback device, which converts mechanical motion into electrical signals to indicate actuator actual position.

The basic configuration of an encoder can be linear or rotary, incremental or absolute. A rotary encoder is typically attached to the rotary motor and measures the motor shaft rotation. Therefore, any windage effect at the ball screw or lost motion due to backlash and friction will not be seen at the encoder. The linear encoder, on the other hand, reads the actual position closer to the point it takes place and therefore the resulting precision is higher.



Linear Encoder

Absolute Encoder - A digital position transducer in which the output is representative of the absolute position of the input shaft within one (or more) revolutions. Output is usually a parallel digital word.

Incremental Encoder - A position transducer in which the output represents incremental changes in position.

Linear Encoder - A digital position transducer that directly measures linear position.

Quadrature Encoder - This is a special incremental encoder with two channels A and B, sometimes referred to as A Quad B. The two channels are 90 degrees out of phase. This configuration allows detection of direction as well as increasing the resolution by a factor of four.

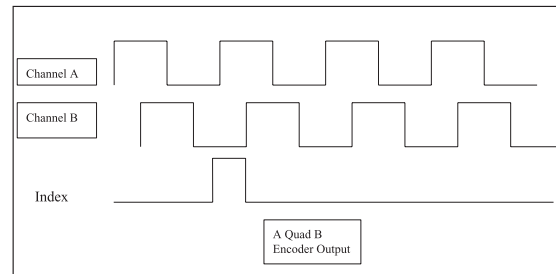

3.3 Controller/Amplifier

Motion Controllers

Motion Controller is an electronic device that communicates with a host computer and has the capability to store a desired motion profile as a function of time or any other reference signal, read the actual position feedback, calculate the error, and send out a command signal to the servo amplifier as a complex function of the error and its derivatives. It can also monitor various I/O signals and control several axes in a coordinated moves.



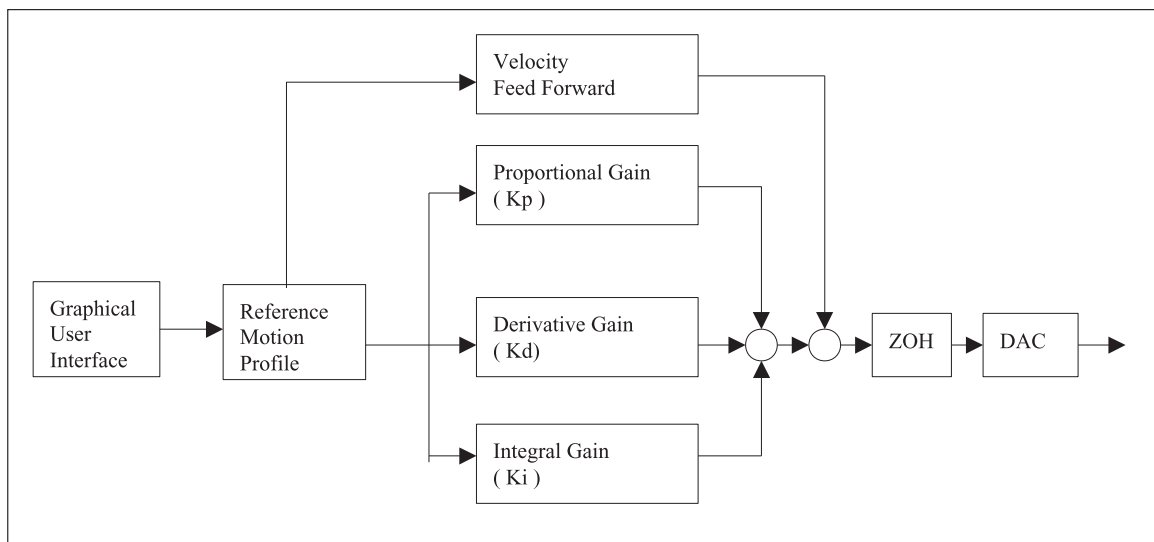

PID controller block diagram with Feed Forward and ZOH

Linear & Rotary Positioning Stages

ZOH - Zero Order Hold represents the controller time delay in processing the input signals before the output to the amplifier is updated.

DAC- Digital to Analog Converter component that receives a digital signal from the controller filter and outputs an Analog signal to the Amplifier.

Compensation: The corrective or control action in a feedback loop system that is used to improve system performance characteristics such as accuracy and response time.

Compensation, Feedforward: A control action that depends on the command only and not the error to improve system response time.

Compensation, Integral: A control action that is proportional to the integral or accumulative time error value product of the feedback loop error signal. It is usually used to reduce static error.

Compensation, Lag: A control action that causes the lag at low frequencies and tends to increase the delay between the input and output of a system while decreasing static error.

Compensation, Lead: A control action that causes the phase to lead at high frequencies and tends to decrease the delay between the input and output of a system.

Compensation, Lead Lag: A control action that combines the characteristics of lead and lag compensations.

Compensation, Proportional: A control action that is directly proportional to the error signal of a feedback loop. It is used to improve system accuracy and response time.

Compensation, Derivative: A control action that is directly proportional to the rate of change of the error signal of the feedback loop. It is used to improve system damping to provide smooth motion and reduce settling time.

Engineering Reference

Linear & Rotary Positioning Stages



Servo Amplifier - An Amplifier that utilizes internal servo feedback loops for accurate control of motor current and or velocity.

Analog Amplifier - An Amplifier that has an analog signal as an input.

Digital Amplifier - An Amplifier in which tuning and parameter setting is done digitally. Input can be an analog or digital signal.

Linear Amplifier - An Amplifier that has output directly proportional to either voltage or current input. Normally both input and output signals are analog.

PWM Amplifier - An Amplifier utilizing Pulse Width Modulation techniques to control power to the motor. Typically a high-efficiency drive that can be used for high response applications.

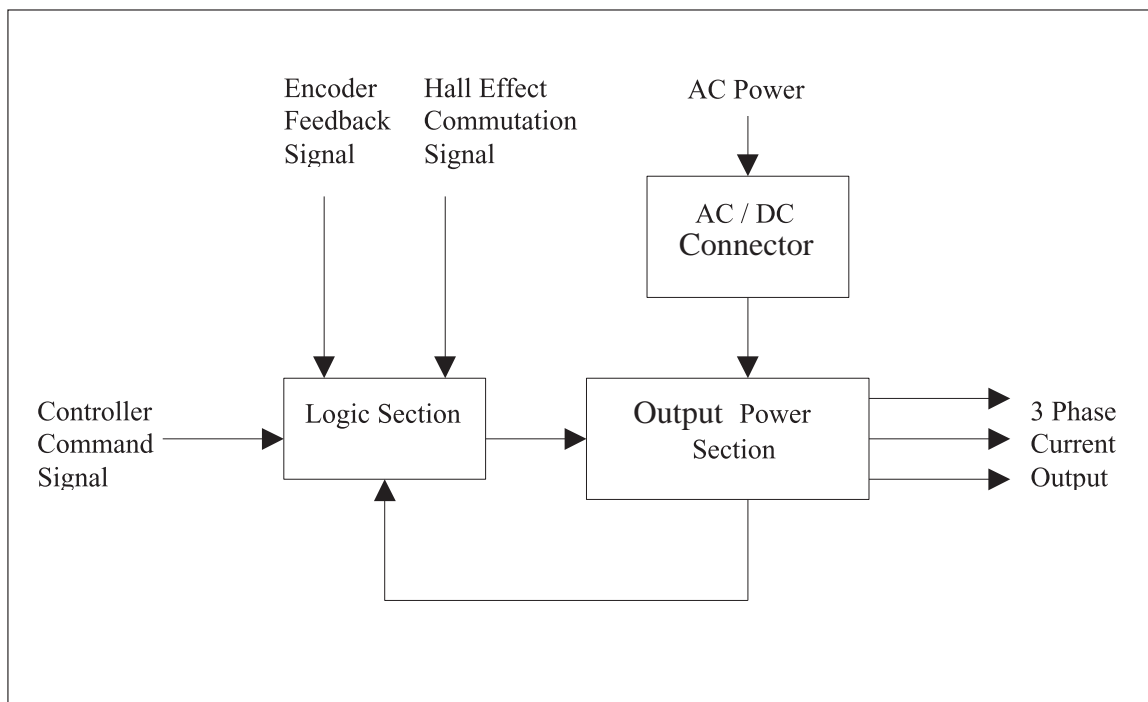

Block Diagram of a Typical Servo Amplifier

4. Positioning System Analysis

4.1 System Modeling

Physical Model

System modeling is important for developing a better understanding of the effects that various design variables, operating conditions and selected motion control components have on the overall positioning system performance. Modeling starts with a physical system to be modeled. For example, the picture shows a positioning system in a compound X,Y,Z configuration. In the following sections we will model and analyze a typical axis of similar machines.

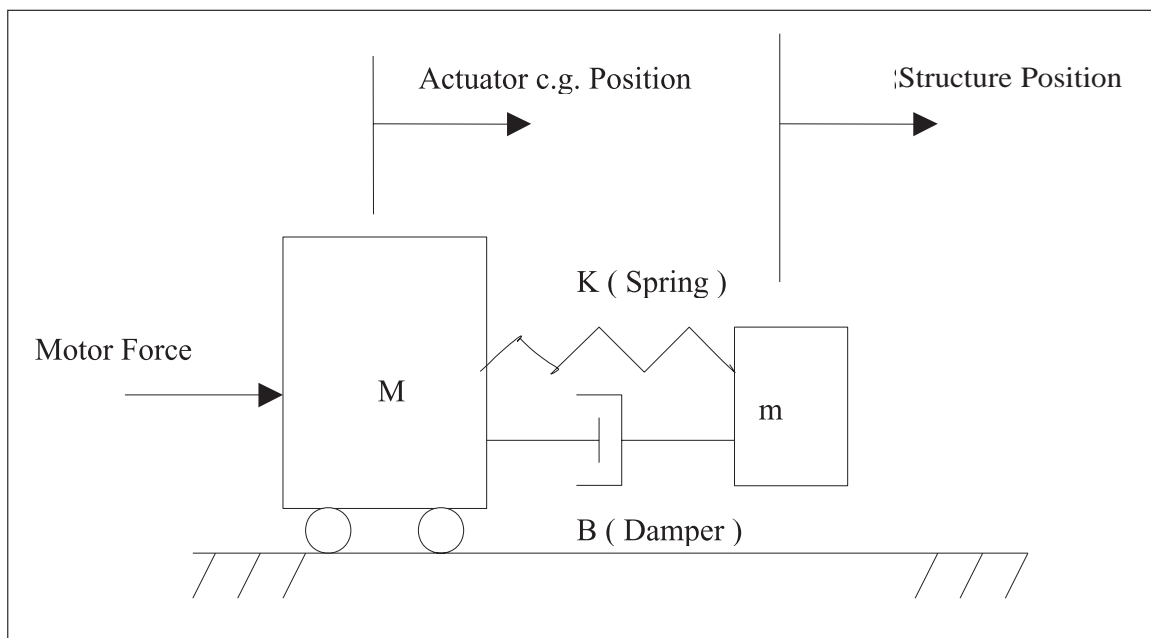

Schematic Diagram

Once the physical model is defined, a schematic diagram shows the main mechanical components, which are included in the theoretical model, and the way they interact. The diagram shows for example a model of a positioning stage with mass M , driven by a motor

force and carrying a flexible structure with mass m , stiffness K and Damping B . The schematic diagram is then used for writing the equations of motion of the theoretical model.

Engineering Reference

Linear & Rotary Positioning Stages

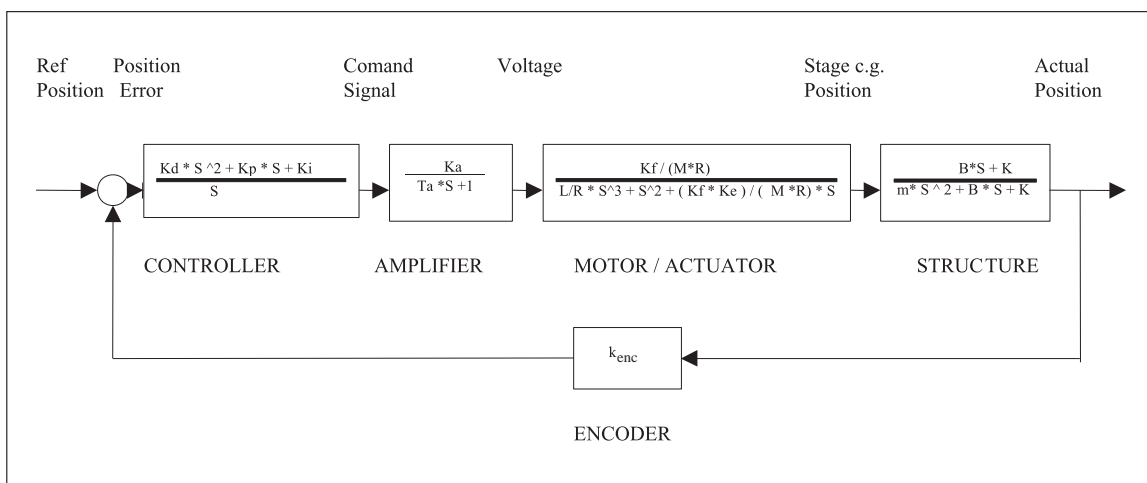

Block Diagram & Transfer Functions

(See section 4.2 for Parameter definitions.)

The block diagram represents the motion control process within the system with all of its modeled components. The arrows represent the flow of signals within the system from one component to another. The blocks themselves contain expressions that are called Transfer Functions. Transfer Functions include operators (e.g., "S" designating differentiation and "1 / S" designating Integration) and parameters that together describe the equations of motion of each block, which relate the output variable of a block to its input

variable. Transfer functions are used to determine the ratio between the magnitude of the output variable to the magnitude of the input variable. This ratio is called "gain" and it is measured in units of dB, where dB is defined as $20 \cdot \text{Log}(\text{output} / \text{Input})$. Furthermore, Transfer Functions are used to calculate the "phase angle" which is the lag or lead of the output signal vs. the input signal measured in degrees. The plot that shows the gain and the phase angle as a function of input frequency is called "Bode Plot".

System Variables and Parameters

The following diagram represents a product tree of a modeled positioning system. The upper section represents various System Variables, which describe the STATIC, SERVO and DYNAMIC

specifications of the machine. These variables are modeled as a function of system parameters as shown below.

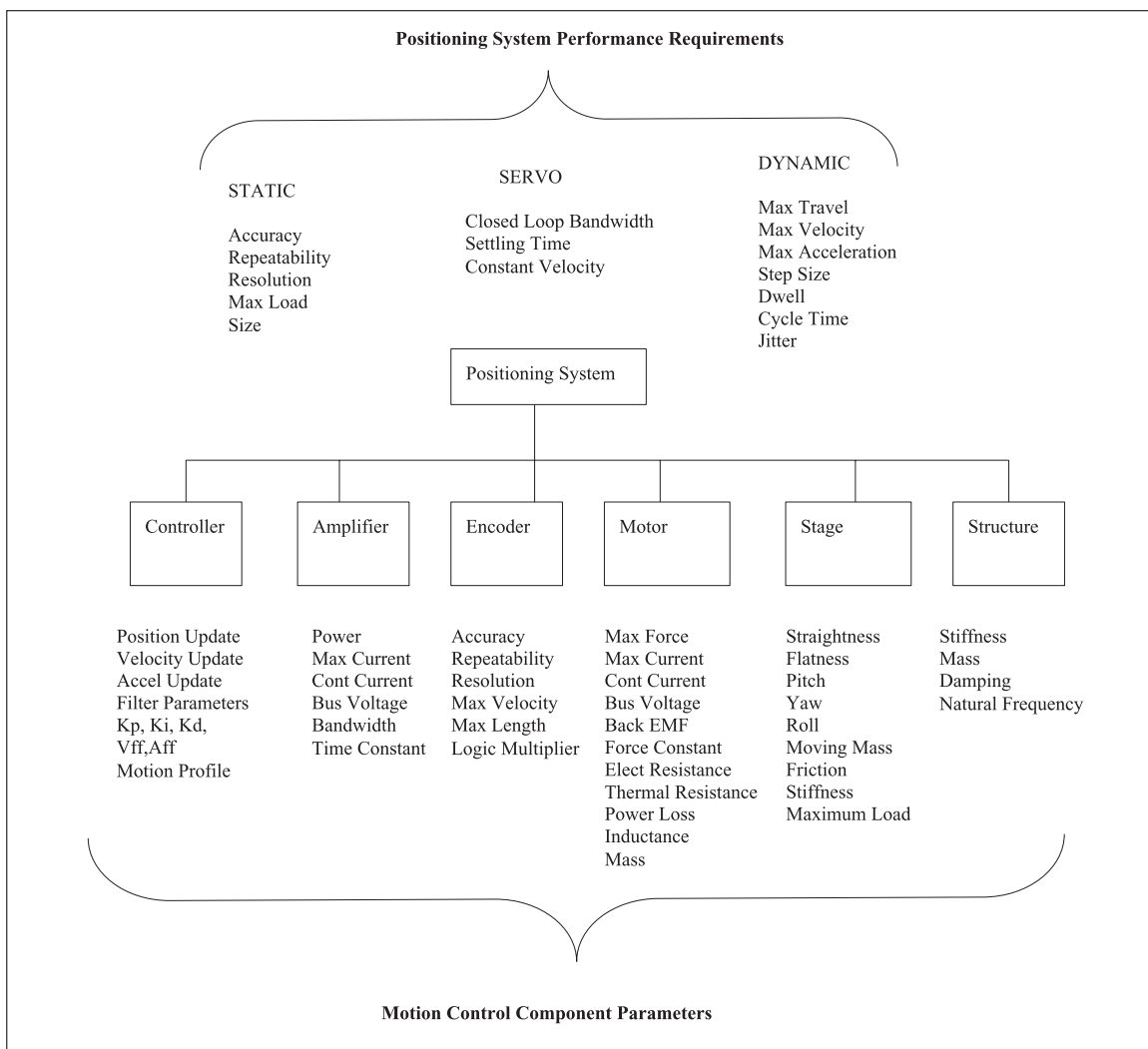

Linear & Rotary
Positioning Stages

The bottom section of the diagram represents system parameters that characterize the various motion control components of the positioning system. These parameters are needed to be selected for various reasons including structural design, component sizing, and

servo tuning. The model relates these parameters to the performance variables as shown above. It can therefore be used to assist in the selection of these parameters to result in a cost-effective solution.

Engineering Reference

Linear & Rotary Positioning Stages

4.2 Frequency Response

The purpose of Frequency Response Analysis, as shown below, is to help in understanding the motion characteristic of each component in the positioning system, as well as the characteristics of the system as a whole. The plots display the "gain" in units of db, ($20 \cdot \log(\text{output} / \text{input})$) and "phase angle" in degrees for each block in the Block Diagram (see section 4.1). Both plots are shown as a function of the frequency of the input variable and referred to as Bode Plots. The frequency in the plots is displayed in logarithmic scale. For example 1 represents 10^1 rad / sec, 2 represents $10^2 = 100$ rad / sec etc. The analysis is important in determining the Closed Loop Bandwidth of the system, as well as its stability.

Components

Controller - PID

The PID transfer function, as shown in section 4.1, has the "positioning error" signal as an input and the "Controller command" signal to the amplifier as an output. It shows high gain (ratio of output signal to input signal) in low frequencies, acting as a low pass filter. It also has high gain at high frequencies, acting as a high pass filter. And finally it has lower gain in some intermediate frequencies, reducing the effects of various vibration causes such as structural resonance, bearing jitter, cogging, and tool vibrations. The low pass filter, caused by the integrator term, K_i , amplifies small errors, such as those caused by friction, and reduces them over time. The high-pass filter, caused by the derivative gain, K_d , allows the system to lead its reaction to high frequency errors. The phase angle of the output signal versus the input signal starts at -90 degrees Lag and ends up at 90 degrees lead. The purpose of the PID transfer function is to shape the overall transfer function of the positioning system, by choosing the right set of PID parameters, K_p , K_i , K_d , to obtain a fast responding, stable, system with high closed-loop bandwidth.

Servo Amplifier

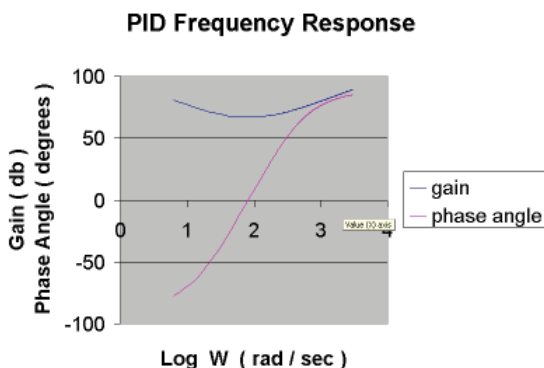

The amplifier transfer function, as shown in section 4.1, has "controller command" signal as an input and "motor voltage" as an output. As shown, the output signal follows the input signal at low frequencies with a constant gain, as determined by the parameter, K_a , of the amplifier. At a certain frequency, called the cutoff frequency, the gain starts to attenuate as frequency increases. The phase angle shows zero lag until the frequency reached the cutoff value, then the output starts to lag to a maximum of -90 degrees at very high frequencies. The cutoff frequency is the inverse of the amplifier time constant T_a , as shown in the transfer function. A time constant is the time it takes for the output signal to reach the level of 63% of a step in the input signal.

Motor/Stage

Amplifier Frequency Response

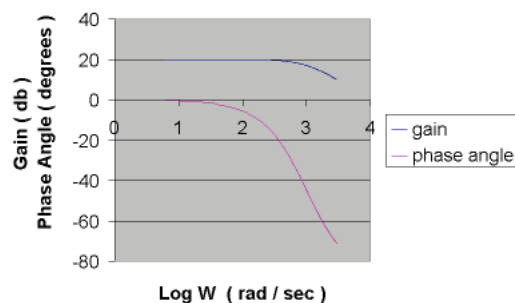

The combined Motor / Stage transfer function, as shown in section 4.1, has "motor voltage" as an input and "stage position" as an output. The gain shows a characteristic of reducing magnitude at a rate of 20 db/decade (decade is a multiple of 10 in frequency change) until a resonant frequency is reached. Then the gain attenuation becomes steeper and reduces at a rate of 60 db/decade. The phase angle starts out at a -90 degrees until the resonance frequency and then it drops an additional 180 degrees to a total of -270. The transfer function of this block has two time constants. One is the electrical time constant of the motor (L/R) and the other is the mechanical time constant of the stage ($M \cdot R / K_f \cdot K_E$). Where,

- L = Motor Coil Inductance
- R = Motor Coil Resistance
- K_f = Motor Force Constant
- K_E = Motor Back EMF
- M = Stage Moving Weight

Structure

Motor / Stage Frequency Response

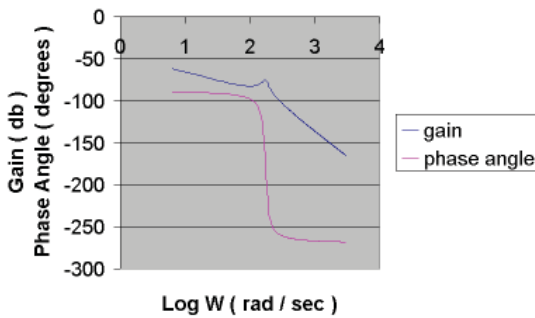

The structure transfer function, as shown in section 4.1 has the "stage position" as an input and the actual "structure position" of a point of interest on the structure (e.g. Encoder location) as the output. This is a classical transfer function of a mass, spring, damper system with a positive position excitation of the base. The gain starts at 1 (zero dB) with low frequencies and gradually increases and reaches a peak at the natural frequency of the structure. Then the gain drops at a rate of 40 dB / decade at higher frequencies. The phase angle starts out as zero, at low frequency, and drops 180 degrees around the natural frequency. Finally it gains additional 90 degrees to a total of -90 degrees at very high frequencies. The parameters that characterize this system are as follows:

- m- Structural Mass
- K- Structural Stiffness
- B- Structural Damping.

Where the natural frequency of the structure $\omega_n = \sqrt{K / m}$

Complete System

Overall Positioning System Bode Plot

Structure Frequency response

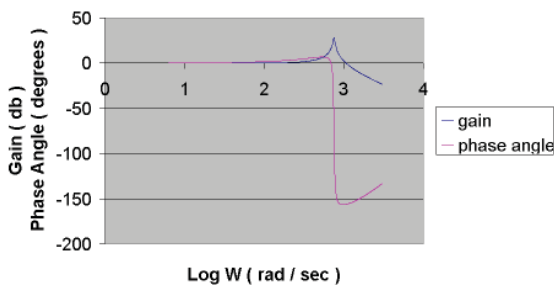

The overall transfer function of the positioning system model, as

shown in the Bode Plot, is made as the superposition of all transfer functions of the individual components. The most important features of this plot are the closed loop bandwidth of the system and the two stability criteria: Phase Margin and Gain Margin. The closed loop bandwidth is determined by the frequency where the gain of the overall transfer function (known as open loop transfer function) crosses the 0 dB line, also referred to as a cross over frequency. The difference between the phase angle at the cross over frequency and -180 degrees is called Phase Margin. For a stable system the Phase margin must be greater than zero. The difference between the gain of zero db and the gain at -180 degrees is called the Gain Margin. For a stable system the gain margin must be greater than zero. The closed loop bandwidth in the example at the chart is about 48 Hz (300 rad / sec, between 10^2 and 10^3 in the chart). The phase margin is about 30 degrees and the gain margin is a few dB, indicating a marginally stable system. The signatures of the PID, Motor / Amplifier and structure are clearly noticeable in the overall plot.

Complete System Frequency Response

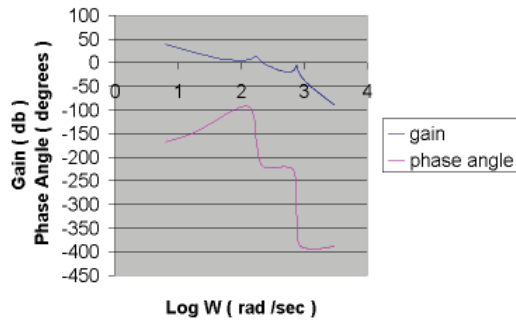

Engineering Reference

Linear & Rotary Positioning Stages

4.3 Simulation

While Frequency Response Analysis, as shown in section 4.2, is used to study the effects of system parameters on the closed loop bandwidth and stability, in the frequency domain, Simulations are frequently used in analyzing system performance in real-time domains. The following analysis will demonstrate the usage of simulation for analyzing motion profiles, settling time, smoothness of motion, motor sizing, dynamic braking and 3D accuracy. These tools are useful in understanding the overall system performance as function of component parameters, operating conditions and design constraints. The Positioning stage model used in the simulation analysis is a PID model with a Motor / Stage Structure. For calculation of the required natural frequency, the gain is assumed to drop at a rate of 60 dB per

decade at the resonant frequency. Furthermore the Gain Margin at the structural resonance is assumed to be zero. (see section 4.2)

Kinematics

Kinematics Analysis assists in selecting the best desired motion profile for a positioning application.

There are infinite possibilities to achieve a desired cycle time with a given travel requirement and various constraints on maximum velocity, maximum acceleration or Jerk. The following is an example of such an analysis. Several iterative runs may be needed to achieve optimal results.

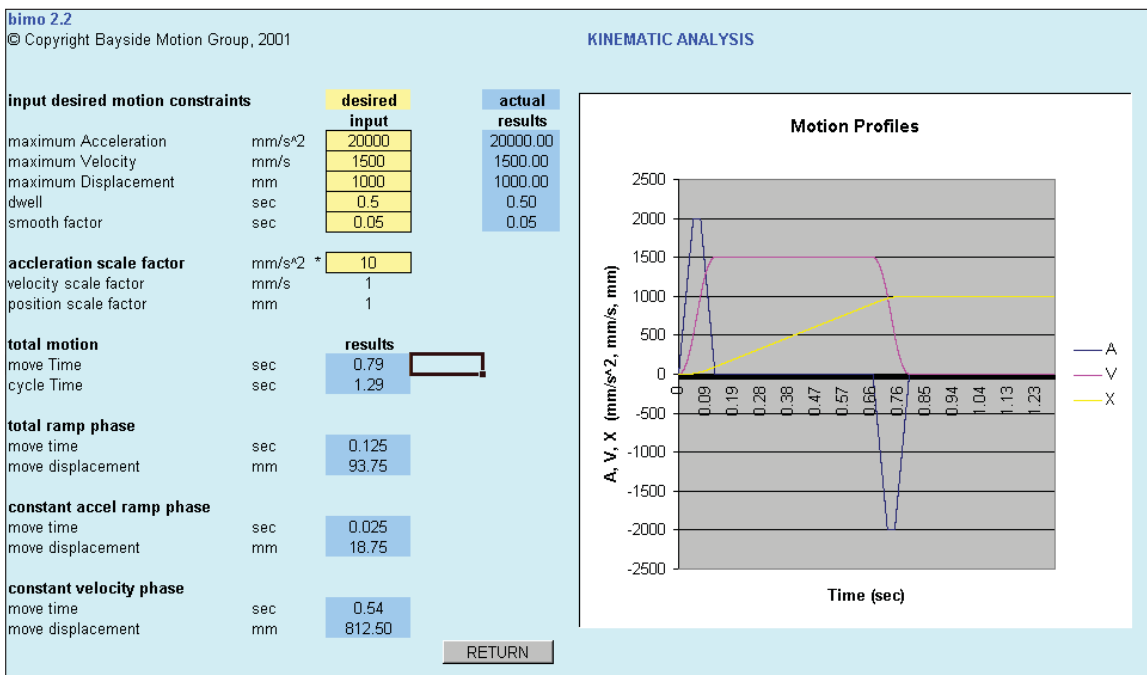

Dynamics & Settling

The Dynamics analysis assists in finding the required motor forces needed to drive the stage in a motion profile, which was determined at the Kinematics Analysis phase. It also determines the Settling time and the Settling distance, at the end of the acceleration phase, to reach the desired constant velocity, as well as the Settling time to reach the desired accuracy at the end of the deceleration phase, during dwell (see section 1.1 dynamics).

The dynamic analysis shown, also determines effects of structural damping, system bandwidth, and system damping on the performance. Finally, recommended structural natural frequency and stiffness, which are required to meet the desired settling time and smoothness of motion, are provided by the model. These values can be used as a basis for a Finite Element Analysis design of the machine structure.

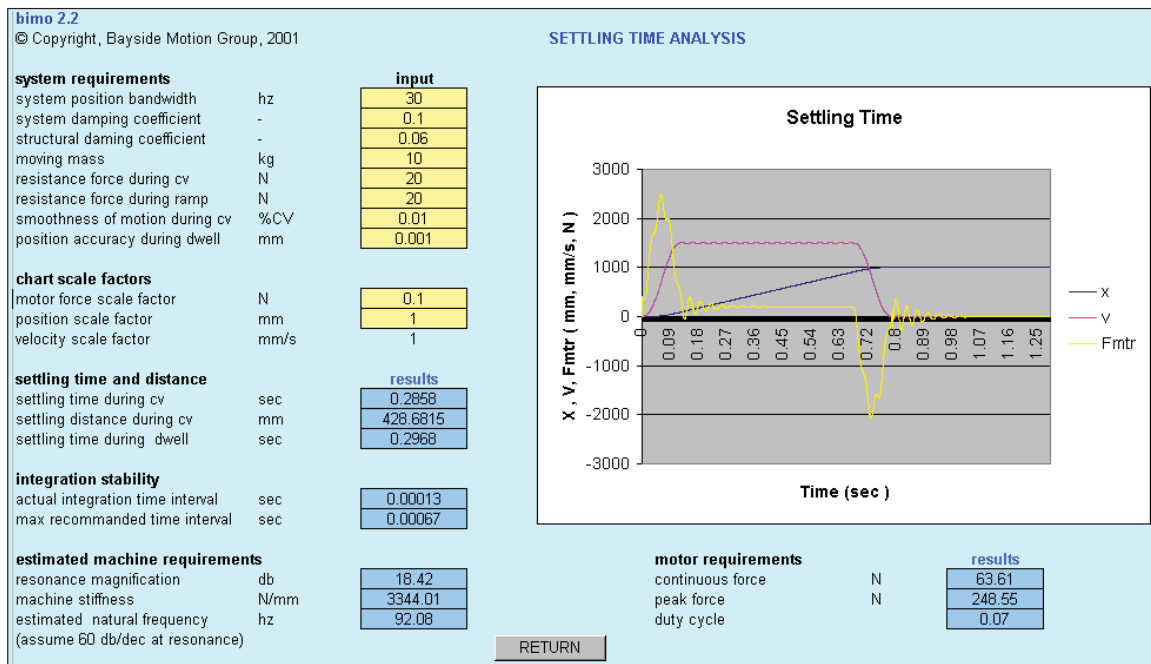

Linear & Rotary Positioning Stages

Engineering Reference

Linear & Rotary Positioning Stages

Linear Motor and Amplifier Sizing

Linear Motor and Amplifier sizing is illustrated at the chart. Force requirements are taken from the results obtained by the dynamic analysis. A motor vendor is then selected. The lowest force motors, which meet the force requirements, are listed automatically for the selected vendor. A choice of motor is made and the specifications are automatically listed. Results display motor temperature, safety margins on forces and required amplifier current and voltage. The graph shows the decaying velocity at the end of constant velocity phase under dynamic

braking conditions. Dynamic braking is typically used when the amplifier fails and the stage continues to travel under inertia forces. During dynamic braking motor coils are put in short circuit. The result is that the back emf voltage of the motor generates current in the coil that develops a force opposite to the direction of velocity. The graph shows the residual velocity that is needed to be absorbed by the hard stops of the stage in this crash conditions, when the state reaches end of travel and hits the hard stops.

bimo 2.2
© Copyright, Bayside Motion Group, 2001

MOTOR / AMPLIFIER SIZING

force requirements

motor continuous force	N	63.61
motor peak force	N	248.55

(note: without coil mass and attraction)

input company / motor selection

company	KOLLMORGEN	select model	IL-12-030-A4
	TRILOGY		IL-12-050-A1

first 13 motors out of: 270

motor specifications

catalog	specifications	KOLLMORGEN valid options
company / motor model	KOLLMORGEN IL-12-030-A4	IL-06-075-A1
continuous force	N 76	IL-06-075-A4
peak force (1 sec)	N 240	IL-06-100-A1
force constant (3 phases)	N/Arms 8	IL-06-100-A4
back emf constant (ptn/rms)	V/m/sec 4	IL-12-050-A1
resistance @ 25C (ptn)	Ohm 0.4	IL-12-050-A2
electrical time constant	msec 0.21	IL-12-050-A4
slider mass	kgm 0.42	IL-12-075-A1
magnet pitch	mm 16	IL-12-075-A2
magnetic attraction	N 0	IL-12-075-A4
thermal resistance	°C/Watt 0.80	IL-12-100-A2
power loss (ptn / 125C)	Watt 131	IL-12-100-A4
maximum coil temperature	°C 130	IL-18-030-A1

motor temperature

coil temperature (above ambient)	C	76.11
----------------------------------	---	-------

safety margins

continuous force	%	19.48
peak force	%	-3.44
coil temperature	%	41.45

company : KOLLMORGEN initial velocity: 1500 mm/sec

motor : IL-12-030-A4 crash velocity: 54.01226 mm/sec

energy to be absorbed: 0.014587 joule

Dynamic Braking

amplifier requirements

continuous current	Arms	7.57
peak current	Arms	29.59
DC bus voltage	V	40.78

3D Precision Analysis

3-Dimensional Precision Analysis is needed to determine effects of various stage parameters, assembly configuration and Abbe offsets on the overall accuracy of the machine. As shown in the example, although each stage has considerably high precision (5 microns) the overall contribution of pitch, yaw and roll and various Abbe offsets of the various stages, this results in an order of magnitude lower 3D accuracy for the assembled system (42 micron).

The analysis further shows that most of the System error is in the global Y direction, and that Stage A has the highest error contribution. It can be therefore concluded that an effective way to improve the error of the entire system, in this case, is by reducing the pitch of Stage A by using, for example, different bearing. (See section 1.3.)

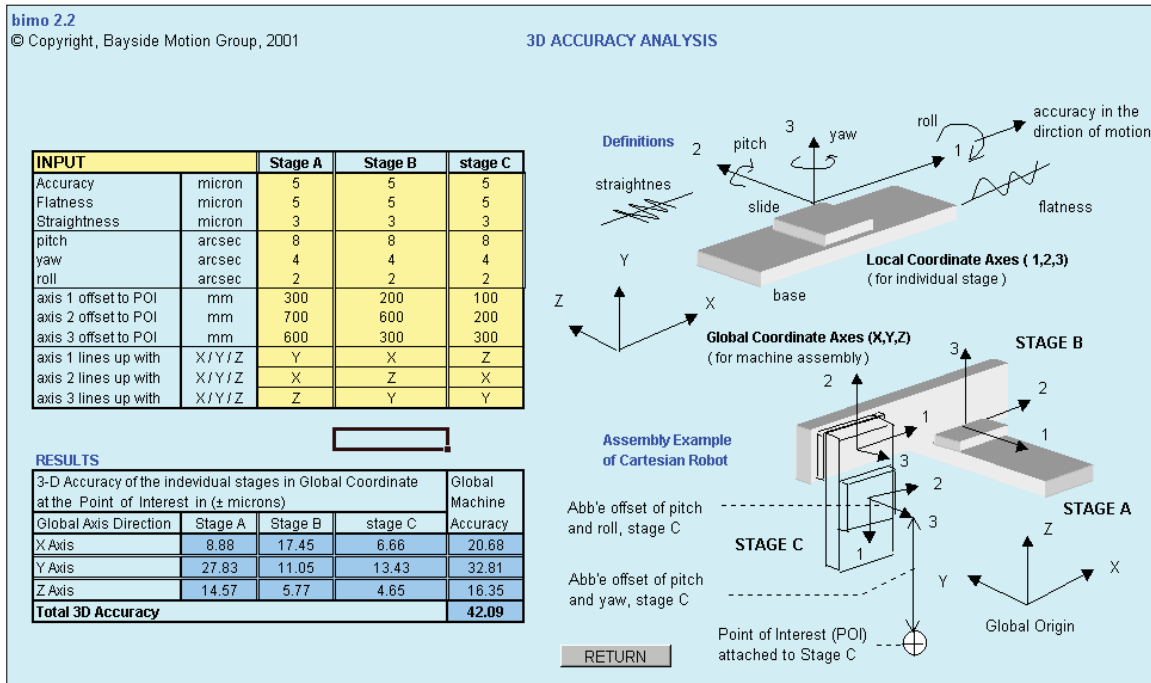

Linear & Rotary Positioning Stages

Engineering Reference

Linear & Rotary Positioning Stages

Absolute Position: Position referenced to a fixed zero position.

Absolute Positioning: Refers to a motion control system employing position feedback devices (absolute encoders) to maintain a given mechanical location.

AC Adjustable-Speed Drive: All equipment required to adjust the speed or torque of AC electric motor(s) by controlling both frequency and voltage applied to the motor(s).

AC Servo Drive: A servo drive used to control either or both synchronous or induction AC motors.

Acceleration: The change in velocity as a function of time. Acceleration usually refers to increasing velocity and Deceleration describes decreasing velocity.

Accuracy: The difference between the expected The maximum deviation between a commanded position and an actual position of a positioning stage. Accuracy is typically specified for ± 3 sigma deviation per given travel.

Actuator: A device which creates mechanical motion by converting various forms of energy to mechanical energy.

Adaptive Control: A technique to allow the control to automatically compensate for changes in system parameters such as load variations.

Abbe Error: A linear positioning error caused by a combination of an angular error in the ways, and an offset between the precision determining element (lead screw, feedback device, etc.) and the actual point of interest.

Ambient Temperature: The temperature of the cooling medium, usually air, immediately surrounding the device such as a motor.

Amplifier: Electronics which convert low level command signals to high power voltages and currents to operate a servomotor.

Bandwidth: Frequency range in which a servo system operates.

Back EMF: The electromagnetic force (voltage) generated as coil windings move through the magnetic field of the permanent magnets in a brushless servomotor. This voltage is proportional to motor speed and is present regardless of whether the motor windings are energized or unenergized.

Ball Screw: A lead screw which has its threads formed as a ball bearing race; the carriage contains a circulating supply of balls for increased efficiency.

Baud Rate: The number of binary bits transmitted per second on a serial communication link (such as RS-232).

Bit (Binary Digit): A unit of information equal to 1 binary decimal or having only a value 0 or 1.

Block Diagram: A simplified representation of a system, with each component represented as a block, and each block positioned in order of signal flow through the system.

Bode Plot: A plot of the magnitude of system gain in dB and the phase of system gain in degrees versus the sinusoidal input signal frequency in logarithmic scale.

Brush: Conducting material which passes current from the DC motor terminals to the rotating commutator.

Brushless Servo Drive: A servo drive used to control a permanent magnet synchronous AC motor. (may also be referred to as AC Servo Drive.)

Bus: A group of parallel connections carrying preassigned digital signals. Buses usually consist of address and data information and miscellaneous control signals for the interconnection of microprocessors, memories, and other computing elements.

Closed Loop: A broadly applied term relating to any system where the output is measured and compared to the input. The output is then adjusted to reach the desired condition. In motion control the term is used to describe a system wherein a velocity or position (or both) transducer is used to generate correction signals by comparison to desired parameters.

Coefficient of Friction: This is defined as the ratio of the force required to move a given load to the magnitude of that load. Typical values for the ball and crossed roller slides are 0.001 to 0.005.

Cogging: A term used to describe non-uniform angular velocity. Cogging appears as a jerkiness especially at low speeds.

Command Position: The desired angular or linear position of an actuator.

Commutation: A term which refers to the action of steering currents or voltage to the proper motor phases so as to produce optimum motor torque. In brush type motors, commutation is done electro mechanically via brushes and commutator. In brushless motors, commutation is done by the switching electronics using rotor position information typically obtained by hall sensors, a resolver or an encoder.

Commutator: A mechanical cylinder consisting of alternating segments of conductive and insulating material. This cylinder used in DC motors passes currents from the brushes into the rotor windings and performs motor commutation as the motor rotates.

Compensation: The corrective or control action in a feedback loop system which is used to improve system performance characteristics such as accuracy and response time.

Compensation, Feedforward: A control action which depends on the command only and not the error to improve system response time.

Compensation, Integral: A control action which is proportional to the integral or accumulative time error value product of the feedback loop error signal. It is usually used to reduce static error.

Compensation, Lag: A control action which causes the lag at low frequencies and tends to increase the delay between the input and output of a system while decreasing static error.

Compensation, Lead: A control action which causes the phase to lead at high frequencies and tends to decrease the delay between the input and output of a system.

Compensation, Lead Lag: A control action which combines the characteristics of lead and lag compensations.

Compensation, Proportional: A control action which is directly proportional to the error signal of a feedback loop. It is used to improve system accuracy and response time.

Compliance: The amount of displacement per unit of applied force.

Coordinated Motion: Multi-axis motion where the position of each axis is dependent on the other axis such that the path and velocity of a move can be accurately controlled (requires coordination between axes).

Critical Damping: A system is critically damped when the response to a step change in desired velocity or position is achieved in the minimum possible time with little or no overshoot.

Damping: An indication of the rate of decay of a signal to its steady state value.

DC Adjustable-Speed Drive: All equipment required to adjust the speed or torque of DC motor(s) by controlling the voltages applied to the armature and/or field of the motors.

DC Drive: An electronic control unit for running DC motors. The DC drive converts AC line current to a variable DC current to control a DC motor. The DC drive has a signal input that controls the torque and speed of the rotor.

Dead Band: A range of input signals for which there is no system response.

Decibel (dB): A logarithmic measurement of gain. If G is a systems gain (ratio of output to input) then $20\log G = \text{gain in decibels (dB)}$.

Detent Torque: The maximum torque that can be applied to an un-energized stepping motor without causing continuous rotating motion.

Drive, Analog: Usually referring to any type of motor drive in which the input is an analog signal.

Drive, Digital: Usually referring to any type of motor drive in which the tuning or compensation is done digitally. Input may be an analog or digital signal.

Drive, Linear: A motor drive in which the output is directly proportional to either a voltage or current input. Normally both inputs and outputs are analog signals.

Drive, PWM: A motor drive utilizing Pulse-Width Modulation techniques to control power to the motor. Typically a high – efficiency drive that can be used for high response applications.

Drive, Servo: A motor drive which utilizes internal feedback loops for accurate control of motor current and/or velocity.

Drive, Stepper: Electronics which convert step and direction inputs to high power currents and voltages to drive a stepping motor. (The stepping motor drive is analogous to the servomotor amplifier).

Duty Cycle: For a repetitive cycle, the ratio of on time to total cycle time: $\text{Duty Cycle} = \text{On Time}/(\text{On Time} + \text{Off Time}) \times 100\%$

Dynamic Braking: A passive technique for stopping a permanent magnet brush or brushless motor. The motor windings are shorted together through a resistor which results in motor braking with an exponential decrease in speed.

Efficiency: The ratio of output power to input power.

Electrical Time Constant: The ratio of armature inductance to armature resistance. The time it takes for a step current input to the coil to reach 63% of its value by overcoming the resistance and the inductance of the coil.

Engineering Reference

Linear & Rotary Positioning Stages

Encoder: A type of feed back device which converts mechanical motion into electrical signals to indicate actuator position. Typical encoders are designed with a printed disc and a light source. As the disc turns with the actuator shaft, the light source shines through the printed pattern onto a sensor. The light transmission is interrupted by the patterns of the disc. These interruptions are sensed and converted to electrical pulses. By counting these pulses, actuator shaft position is determined.

Encoder, Absolute: A digital position transducer in which the output is representative of the absolute position of the input shaft within one (or more) revolutions. Output is usually a parallel digital word.

Encoder, Incremental: A position encoding device in which the output represents incremental changes in position.

Encoder, Linear: A digital position transducer which directly measures linear position.

Encoder Marker: A once-per-revolution signal provided by some incremental encoders to specify a reference point within that revolution.

Encoder Resolution: A measure of the smallest positional change which can be detected by the encoder.

Explosion-proof: A motor classification that indicates a motor is capable of withstanding internal explosions without bursting or allowing ignition to reach beyond the confines of the motor frame.

Feedback: A signal which is transferred from the output back to the input for use in a closed loop system.

Filter (Control Systems): A transfer function used to modify the frequency or time response of a control system.

Flatness of Travel: Deviation from ideal straight line travel in a vertical plane, also referred to as vertical runout.

Following Error: The positional error during motion resulting from use of a position control loop with proportional gain only.

Friction: A resistance to motion caused by surfaces rubbing together. Friction can be constant with varying speed (coulomb friction) or proportional to speed (viscous friction) or present at rest (static friction).

Full Load Current: The armature current of a motor operated at its full load torque and speed with rated voltage applied.

Full Load Speed: The speed of a motor operated with rated voltage and full load torque.

Gain: The ratio of system output signal to system input signal. The control loop parameter that determines system performance characteristics.

Hall Sensors: A feedback device which is used in a brushless servo system to provide information for the amplifier to electronically commutate the motor. The device uses a magnetized wheel and hall-effect sensors to generate the commutation signals.

Holding Torque: Sometimes called static torque, it specifies the maximum external force or torque that can be applied to a stopped, energized motor without causing the rotor to rotate continuously.

Home Position: A reference position for all absolute positioning movements. Usually defined by a home limit switch and/or encoder marker. Normally set at power up and retained for as long as the control system is operational.

Horsepower (HP): One horsepower is equal to 746 watts. Since $\text{Power} = \text{Torque} \times \text{Speed}$, horsepower is a measure of a motor's torque and speed capability (e.g. a 1 HP motor will produce 35 in-lb. at 1,800 RPM).

Host Computer: An auxiliary computer system which is connected to a controller or controllers. The host computer in distributed control systems is frequently involved with controlling many remote and distributed motion control devices. It may also be used for off-line

Hunting: The oscillation of the system response about a theoretical steady-state value.

Hybrid Stepping Motor: A motor designed to move in discrete increments or steps. The motor has a permanent magnet rotor and wound stator. These motors are brushless and phase currents are commutated as a function of time to produce motion.

Hysteresis: For a system with an analog input and digital output, the output value is dependent on both the input value and output state such that there is an input range over which the output can be high or low.

I/O: Input/Output: The reception and transmission of information between control devices. In modern control systems, I/O has two distinct forms: switches, relays, etc. which are in either an on or off state, or analog signals that are continuous in nature such as speed, temperature, flow, etc.

Idle Current Reduction: A stepping motor driver feature that reduces the phase current to the motor when no motor motion (idle) is commanded for a specified period of time. This reduces motor heating and allows high machine throughput to be obtained from a given motor.

Incremental Motion: A motion control term that is used to describe a device that produces one step of motion for each step command (usually a pulse) received.

Indexer: Electronics which convert high level motion commands from a host computer, programmable controller, or operator panel into step and direction pulse streams for use by the stepping motor driver.

Inductance: The tendency of a motor coil to store energy in a magnetic field. High speed stepping motor performance is inversely proportional to motor inductance.

Inertia: The property of an object to resist changes in velocity unless acted upon by an outside force. Higher inertia objects require larger torques to accelerate and decelerate. Inertia is dependent upon the mass and shape of the object.

Inertial Match: An inertial match between motor and load is obtained by selecting the coupling ratio such that the load moment of inertia referred to the motor shaft is equal to the motor moment of inertia.

Lead Screw: A device for translating rotary motion into linear motion, consisting of an externally threaded screw and an internally threaded carriage (nut).

Limits: Motion control systems may have sensors called limits that alert the control electronics that the physical end of travel is being approached and that motion should stop.

Linear Coordinated Move: A coordinated move where the path between endpoints is a line.

Linearity: For a speed control system it is the maximum deviation between actual and set speed expressed as a percentage of set speed.

Loop, Feedback Control: A control method that compares the input from a measuring device, such as an encoder or tachometer, to a desired parameter, such as position or velocity and causes action to correct any detected error. Several types of loops can be used in combination (i.e. velocity and position together) for high performance requirements.

Loop Gain, Open: The product of the forward path and feedback path gains.

Loop, PID: Proportional, Integral, and Derivative Loop: Specialized very high performance control loop which gives superior response.

Loop, Position: A feedback control loop in which the controlled parameter is motor position.

Loop, Velocity: A feedback control loop in which the controlled parameter is mechanical velocity.

Master Slave Motion Control: A type of coordinated motion control where the master axis position is used to generate one or more slave axis position commands.

Mechanical Time Constant: The time for an unloaded motor to reach 63.2% of its final velocity after the application of a DC armature voltage.

Microstepping: An electronic control technique that proportions the current in a step motor's windings to provide additional intermediate positions between poles. Produces smooth rotation over a wide speed range and high positional resolution.

Mid-Range Instability: A phenomenon in which a stepping motor can fall out of synchronism due to loss of torque at mid-range speeds. The loss of torque is due to interaction between the motor's electrical characteristics and the driver electronics. Some drivers have circuitry to eliminate or reduce this phenomenon.

Motor, AC: A device that converts electrical alternating current into mechanical energy. Requires no commutation devices such as brushes. Normally operated off commercial AC power. Can be single or multiple phase.

Motor, AC Asynchronous or Induction: An AC motor in which speed is proportional to the frequency of the applied AC. Requires no magnets or field coil. Usually used for non-precise constant speed applications.

Motor, AC Synchronous: Another term for brushless DC motor.

Motor Constant: The ratio of the motor torque to motor input power.

Motor, DC: A device that converts electrical direct current into mechanical energy. It requires a commutating device, either brushes or electronic. Usually requires a source of DC power.

Motor, DC Brushless: A type of direct current motor that utilizes electronic commutation rather than brushes to transfer current.

Motor, DC Permanent Magnet: A motor utilizing permanent magnets to produce a magnetic field. Has linear torque speed characteristics.

Motor, Stepping: A specialized AC motor that allows discrete positioning without feedback. Normally used for non-critical, low-power applications, since positional information is easily lost if acceleration or velocity limits are exceeded. Load variations can also cause loss of position. If encoders are used, these limitations can be overcome.

Engineering Reference

Linear & Rotary Positioning Stages

NC, Numerical Control: Usually refers to any type of automated equipment or process used for contouring or positioning.

No Load Speed: Motor speed with no external load.

Open-Loop System: A system where the command signal results in actuator movement but, because the movement is not sensed, there is no way to correct for error. Open loop means no feedback.

Operator Interface: A device that allows the operator to communicate with a machine. This device typically has a keyboard or thumbwheel to enter instructions into the machine. It also has a display device that allows the machine to display messages.

Optical Encoder: A linear or angular position feedback device, typically providing incremental two channel information in quadrature format (sine or square waves with a 90-degree phase shift between each channel). Such two channel information allows simple counter circuits to function as absolute position indicators.

Optically Isolated: A system or circuit that transmits signals with no direct electrical connection. Used to protectively isolate electrically noisy machine signals from low-level control logic.

Orthogonality: The degree of perpendicularity, or squareness, between the two axes in an X-Y or X-Z table. This parameter is usually measured in arc-seconds or microradians.

Oscillation: An effect that varies periodically between two values.

Overshoot: The amount that the parameter being controlled exceeds the desired value for a step input.

Phase-Locked Servo System: A hybrid control system in which the output of an optical tachometer is compared to a reference square wave signal to generate a system error signal proportional to both shaft velocity and position errors.

Pitch: An angular deviation possible in positioning systems, in which the table's leading edge rises or falls as the table translates along its direction of travel. This represents rotation around a horizontal axis, perpendicular to the direction of travel.

Programmable Logic Controller (PLC): This device is used for machine control and sequencing.

Proportional-Integral-Derivative (PID): An acronym that describes the compensation structure that can be used in a closed-loop system.

Point-to-Point Move: A multi-axis move from one point to another where each axis is controlled independently. (No coordination between axes is required).

Position Error: The difference between the present actuator (feedback) value and the desired position command for a position loop.

Position Feedback: Present actuator position as measured by a position transducer.

Power: The rate at which work is done. In motion control, $\text{Power} = \text{Torque} \times \text{Speed}$.

Process Control: A term used to describe the control of machine or manufacturing processes, especially in continuous production environments.

PWM Pulse Width Modulation: An acronym which describes a switch-mode control technique used in amplifiers and drivers to control motor voltage and current. This control technique is used in contrast to linear control and offers the advantages of greatly improved efficiency.

Pulse Rate: The frequency of the step pulses applied to a stepper motor driver. The pulse rate divided by the resolution of the motor / drive combination (in steps per revolution) yields the rotational speed in revolutions per second.

Quadrature: Refers to signal characteristics of interfaces to positioning devices such as encoders or resolvers. Specifically, that property of position transducers that allows them to detect direction of motion using the phase relationship of two signal channels. (A type of incremental encoder output in which the two square wave outputs are offset by 90 degrees).

Rated Torque: The torque producing capacity of a motor at a given speed. This is the maximum continuous torque the motor can deliver to a load and is usually specified with a torque/speed curve.

Repeatability: The degree to which the positioning accuracy for a given move performed repetitively can be duplicated.

Resolution: The smallest positioning increment that can be achieved. Frequently defined as the number of steps or feedback units required for a motor's shaft to rotate one complete revolution.

Resolver: A position transducer utilizing magnetic coupling to measure absolute shaft position over one resolution.

Resonance: The effect of a periodic driving force that causes large amplitude increases at a particular frequency. (Resonance frequency).

RFI: Radio Frequency Interference

Robot: A reprogrammable multifunctional manipulator designed to move material, parts, tools or specialized devices through variable programmed motions for the performance of a variety of tasks.

Robot Control: A computer-based motion control device to control the servo-axis motion of a robot.

Roll: An angular deviation from ideal straight line motion, in which the positioning table rotates around its axis of travel as it translates along that axis.

Root Mean Square Current (RMS Current): In an intermittent duty cycle application, the RMS current is equal to the value of steady state current which would produce the equivalent resistive heating over a long period of time.

Root Mean Square Torque (RMS Torque): For an intermittent duty cycle application, the RMS torque is equal to the steady state torque which would produce the same amount of motor heating over long periods of time.

Rotor: The rotating part of a magnetic structure. In a motor, the rotor is connected to the motor shaft.

Serial Port: A digital data communication port configured with a minimum number of signal lines. This is achieved by passing binary information signals as a time series of "1"s and "0"s on a single line.

Servo Amplifier/Servo Drive: An electronic device which produces the winding current for a servomotor. The amplifier converts a low-level control signal into high voltage and current levels to produce torque in the motor.

Servo System: An automatic feedback control system for mechanical motion in which the controlled or output quantity is position, velocity, or acceleration. Servo systems are closed loop systems.

Settling Time: The time required for a step response of a system parameter to stop oscillating or ringing and reach its final value.

Slew: In motion control, the portion of a move made at a constant non-zero velocity.

Slew Speed: The maximum velocity at which an encoder will be required to perform.

Stall Torque: The torque available from a motor at stall or zero rpm.

Stator: The non-rotating part of a magnetic structure. In a motor, the stator usually contains the mounting surface, bearings, and non-rotating windings or permanent magnets.

Stiffness: Ratio of an applied force or torque to change in position for a mechanical system. Ability of an object to resist deformation.

Straightness of Travel: Deviation from straight line motion in a horizontal plane. Also referred to as horizontal runout. This error is usually traceable to an underlying angular error of the ways.

Tachometer: An electromagnetic feedback transducer which produces an analog voltage signal proportional to rotational velocity. Tachometers can be either brush or brushless.

T.I.R.: This stands for Total Indicator Reading, which reflects the total absolute deviation from a mean value (versus a + value which indicates the deviation from a nominal value).

Torque: The rotary equivalent to force. Equal to the product of the force perpendicular to the radius of motion and distance from the center of rotation to the point where the force is applied.

Torque Constant: A number representing the relationship between motor input current and motor output torque. Typically expressed in units of torque / amp.

Torque Ripple: The cyclical variation of generated torque given by product of motor angular velocity and number of commutator segments.

Torque-to-Inertia Ratio: Defined as a motor's torque divided by the inertia of its rotor, the higher the ratio the higher the acceleration will be.

Transducer: Any device that translates a physical parameter into an electrical parameter. Tachometers and encoders are examples of transducers.

Trapezoidal Profile: A motion profile in which the velocity vs. time profile resembles a trapezoid. Characterized by constant acceleration, constant velocity, and constant deceleration.

TTL: Transistor-Transistor Logic.

Velocity: The change in position as a function of time. Velocity has both a magnitude and a direction.

Velocity Ripple: Disturbances in the programmed velocity profile due to changes in magnetic flux and commutation switching.

Voltage Constant: (or Back EMF Constant) A number representing the relationship between Back EMF voltage and angular velocity. Typically expressed as V / kRPM.

Yaw: An angular deviation from ideal straight line motion, in which the positioning table rotates around the Z (vertical) Axis as it translates along its travel axis.