



XL, XLT & XLi Series stepping motor drives

*192-100612 N2 / UK
October, 2004*



A product specifically for the OEM & system builder



XL, XLT & XLi Series stepper motor drives

The XL family of stepper motor drives and power supplies from Parker Hannifin's Electromechanical Division bring new standards of economy for the systems builder and original equipment manufacturer. Derived from the successful L series modular drives, the XL range represents exceptional value without compromising on performance.

Parker has taken the core of the L series plug-in drive and housed it in a robust, 'no-frills' aluchrome aluminium casing. Equipped with screw terminals and D-type connectors, the resulting package is suitable for direct panel mounting in the equipment cabinet. Installation is particularly straightforward - cooling is either by natural convection or by an internal fan, depending on the current rating, so no cold plate is needed as with many competitive products.

The XL range comprises three basic drive types. The XL single axis step-direction version permits operation from an independent controller, while the three-axis XLT step-direction version permits space saving in multi-axis systems. The intelligent XLi indexer version, with an optional CANopen interface, provides a stand-alone drive/controller package capable of solving a wide range of automation applications.

Common features on all XL series stepper drives include programmable motor current down to 50% of the maximum value, automatic current reduction at standby, a choice of four resolutions between 400 and 4000 steps/rev and full protection against short circuits, overvoltage and excessive temperature rise. The drives comply fully with European LVD and EMC requirements when installed according to the information in the User Guide.

All drive types are available in three current ratings, giving an output of either 2.5A, 5A or 8A peak per phase.

An advanced indexer with CANbus option

XLi Series intelligent drives incorporate a powerful indexer based on Parker's proven EASI control language. In addition to all standard motion control functions, the indexer can perform accurate registration moves for applications such as packaging and labelling. The use of pre-defined move profiles and labelled program blocks allows for more efficient programming and improves the response of the indexer by reducing execution time. The indexer operating system is held in Flash-ROM to allow for straightforward field upgrades and enhancements. Optimum noise immunity is assured by the use of PLC-compatible 24V input and output levels.

An optional CANopen interface in the XLCAN model allows indexer commands to be sent using some of the objects specified in the CANopen standards DS301 and DS402. Additional objects allow the user to take advantage of the more advanced indexer features, such as registration.

All XLi intelligent drives are shipped with a copy of EASI-Tools, a Windows™-based software package designed to get your system up and running in the minimum time. As well as performing the functions of a terminal emulator, EASI-Tools allows you to configure the drive and to create, edit and save all your motion programs. It will run under Windows™ 95/98, ME, 2000 or NT4.

Power supplies & motors

The XL-PSU and PL1100 power supplies offer a convenient way of powering XL Series drives. The XL-PSU module has been designed to operate up to six XL stepper drives (depending on shaft loading) and operates directly from any AC voltage between 95V and 264V. For more demanding applications the transformer-fed PL1100 power supply module is capable of delivering up to 14A at 80VDC.

Parker SY stepper motors are particularly suitable for use with XL Series drives. They offer excellent performance in relation to price and are available in a range of flange sizes and stack lengths. The smaller flange sizes may be supplied either with screw terminals or flying leads, and additional variants are available including double shaft, enhanced IP rating and alternative windings. Mechanical details, dimensions and performance curves will be found at the end of this brochure.

Drive specifications

Main specifications, all versions

Output current per phase	XL25/25i/25CAN & XLT25: 2.5A peak (1.8A RMS) ±10% XL50/50i/50CAN & XLT50: 5.0A peak (3.5A RMS) ±10% XL80/80i/80CAN & XLT80: 8.0A peak (5.6A RMS) ±10%
Output current adjustment	By bit switch (XL & XLT) or by software (XLi/XLCAN)
Current adjustment range	50% - 100% of drive peak current rating
Automatic standby reduction	50% or 70% of programmed current
Standby reduction time	30mS from last step pulse
Drive resolution	400, 800, 2000 or 4000 steps/rev
Minimum motor inductance	0.5mH
Recommended inductance range	0.8mH - 10mH
Motor supply voltage	2.5A/phase models: 24 - 80VDC nominal (20 - 84V abs. limits) 5.0A & 8.0A/phase models: 48 - 80VDC nominal (40 - 84V abs. limits)
Recommended PSU capacitance	2.5A/phase models: 2200µF/axis 5.0A & 8.0A/phase models: 3300µF/axis
Logic supply voltage	24V DC +10% -15% (not required on XLT25/XLT50)
Logic supply current	XL25/50 and XLT80: 100mA; XL80 150mA XL25i/50i: 200mA (no outputs loaded), 600mA max. with all outputs loaded XL80i: 250mA (no outputs loaded), 650mA max. with all outputs loaded
Protection	Motor overcurrent/short circuit, over & under voltage, logic supply fault, *over temperature (*not on XLT25/XLT50)
Ambient temperature range	0° - 50°C; cooling by natural convection, fan-assisted on 8.0A/phase models
Humidity	0% - 95%, non-condensing
Weight	0.4 - 0.6kg

XL & XLT step-direction drives

Command input	Step/direction or step-up/-down, configurable in hardware; differential TTL levels
Step-pulse generator (XL drives only):	
Fast speed range	0 - 50rps (at 4000 steps/rev)
Slow speed range	0 - 8rps
Acceleration/deceleration time	45mS/30mS, may be increased by external capacitor

XLi & XLCAN intelligent drives

Communication	RS232, 9600 baud, 8 data bits, 1 start bit, 1 stop bit, no parity
CANopen interface (XLCAN only)	Communications profile based on DS301; device profile based on DS402 PDO : 2 Tx/2 Rx; SDO : 1 Tx/1 Rx; communication rates up to 1MHz
Addressing	1 - 255, selected by software
Digital I/O	8 configurable I/O ports, 24V DC operation
Max. load per output	200mA
Max. total output load	400mA
Positioning range	±2,147,483,647 steps
Velocity range	0.01 to 50 revs/sec
Acceleration range	0.1 to 1024 revs/sec ²
Positioning modes	Incremental, absolute, registration, continuous run

XL Series Power Supplies

XL Series drives are powered by an external DC supply in the range 48-80VDC for the motor supply, plus a 24VDC logic supply where required. Parker can offer a choice of two power supply systems which are suitable for use with the XL Series drives.

The XL-PSU power supply module offers a convenient way of powering up to six XL series stepper drives. Operating directly from all AC supplies between 95V and 264V, it has a continuous rated output of 250W at 230VAC input with a 1-second peak rating of 600W. The XL-PSU supplies both the main 80VDC supply rail and the 24VDC logic voltage - no external EMC filters are required unless the motor leads are exceptionally long (greater than 30m).

The transformer-fed PL1100 supply has a 1.1kW rating and is suitable for powering up to twenty-four XL series stepper drives in applications with typical duty cycles. Separate mains transformers may be used for the main 80VDC rail and the 24V logic supply, allowing communication to be retained during shutdown. To minimise cost, EMC filters are not included so that where appropriate a common filter system may be used. To power the PL1100 power supply, Parker offers the TO255 1kVA high-voltage toroidal transformer for the motor supply and the TO256 120VA low-voltage toroidal transformer for the logic supply. Both transformers can be wired to permit operation from either 115 or 230VAC mains supplies.

As a guide, the XL-PSU can supply up to six 2.5A axes, three 5A axes or two 8A axes, assuming typical duty cycles, whilst the PL1100 can supply up to twenty-four 2.5A axes, twelve 5A axes or eight 8A axes, again with typical duty cycles.

PL1100 power supply specification

AC input voltage, nominal	55V AC, 1 ϕ or 3 ϕ
absolute maximum	61V AC
Main DC output, nominal	75V DC, 12A max. (on 1 ϕ) 14A max. (on 3 ϕ)
Logic supply output	24V DC, 3A max.
Rated output power	950W (on 1 ϕ), 1.1kW (on 3 ϕ)
Power factor at full load	0.9
Power dump resistor (if required)	5R, 100W
Main EMC filter*	Corcom 12FC10 (for 1 ϕ), Corcom 12FCD10 (for 3 ϕ)
24V EMC filter	Corcom 3VK1
Dimensions (h \times w \times d)	145 x 119 x 143mm
Weight	1.25kg

*For motor leads up to 30m long

XL-PSU power supply performance

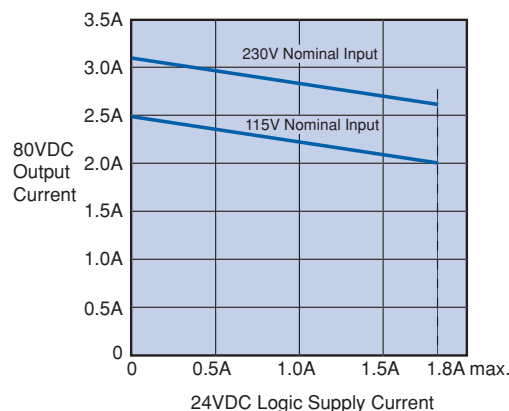

XL-PSU specification

AC input voltage, nominal	115V to 230V AC, 1 ϕ
absolute limits	95 to 264V AC
Main DC output	80V DC, 3.1A max. cont.*
Logic supply output	24V DC, 1.8A max.
Rated total output power	250W cont. @ 230VAC in
Peak power (1-sec rating)	600W
Power factor at full load	0.9
Power dump resistor (if required)	10R, 100W
Weight	1kg

*Dependent on supply voltage and 24V power drawn, as shown in performance graph above

TO255/TO256 specifications

Primary input	115 or 230VAC, 1 ϕ +15% / -10%
TO255 Motor Supply Transformer	
Secondary Voltage	2x 50VAC _{RMS} full load voltage
Secondary Current	2x 10A _{RMS}
Power Rating	1000VA
Regulation	3.5%
Dimensions (DIA \times H)	165 x 75mm
Weight	6.5kg
TO256 Logic Supply Transformer	
Secondary Voltage	2x 18VAC _{RMS} full load voltage
Secondary Current	2x 3.3A _{RMS}
Power Rating	120VA
Regulation	5.5%
Dimensions (DIA \times H)	104 x 52mm
Weight	1.2kg

Drive & power supply dimensions

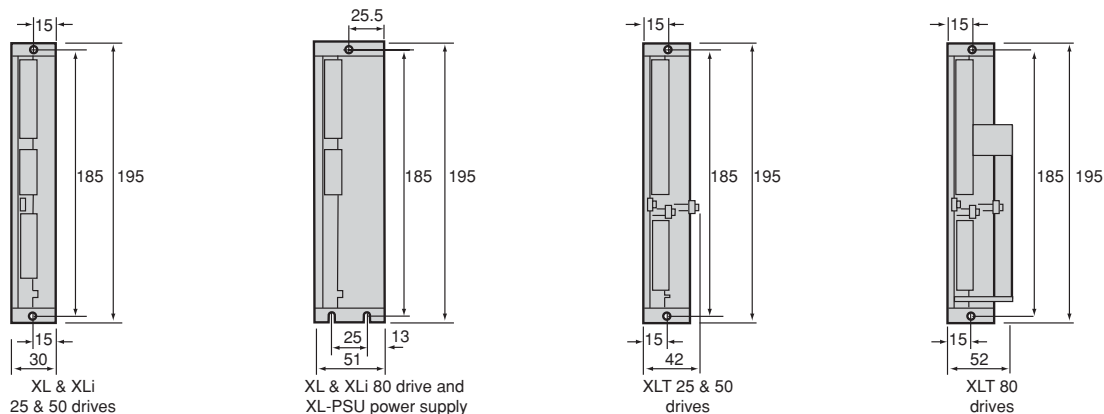

All mounting holes 4.5mm diameter

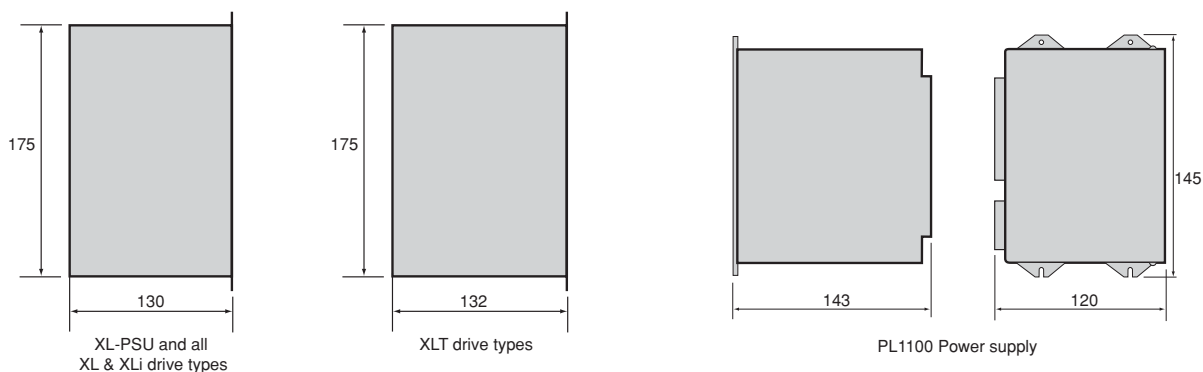

Product ordering codes

XL25 2.5A/phase, Step/Direction Drive
 XL50 5.0A/phase, Step/Direction Drive
 XL80 8.0A/phase, Step/Direction Drive

XLT25 2.5A/phase, 3-Axes, Step/Direction Drive
 XLT50 5.0A/phase, 3-Axes, Step/Direction Drive
 XLT80 8.0A/phase, 3-Axes, Step/Direction Drive

XL25i 2.5A/phase, Intelligent Drive
 XL50i 5.0A/phase, Intelligent Drive
 XL80i 8.0A/phase, Intelligent Drive

XL25CAN 2.5A/phase, Intelligent Drive with CANopen
 XL50CAN 5.0A/phase, Intelligent Drive with CANopen
 XL80CAN 8.0A/phase, Intelligent Drive with CANopen

XL-PSU 250W DOL Power Supply Module
 XL-DUMP 10R, 100W dump resistor for XL-PSU
 XL-CONNECT Interconnect kit (single axis XL)

PL1100 1.1kW Linear Power Supply Module
 PL1100-DUMP 5R, 200W dump resistor for PL1100
 TO255 1000VA Motor Supply Transformer
 TO256 120VA Logic Supply Transformer

STC20-0300 Motor cable, M20x1.5 gland, 3m length
 STC20-0500 Motor cable, M20x1.5 gland, 5m length
 STC20-1500 Motor cable, M20x1.5 gland, 15m length

192-100612 N2 / UK
XL, XLT & XLi Series

Motor dimensions

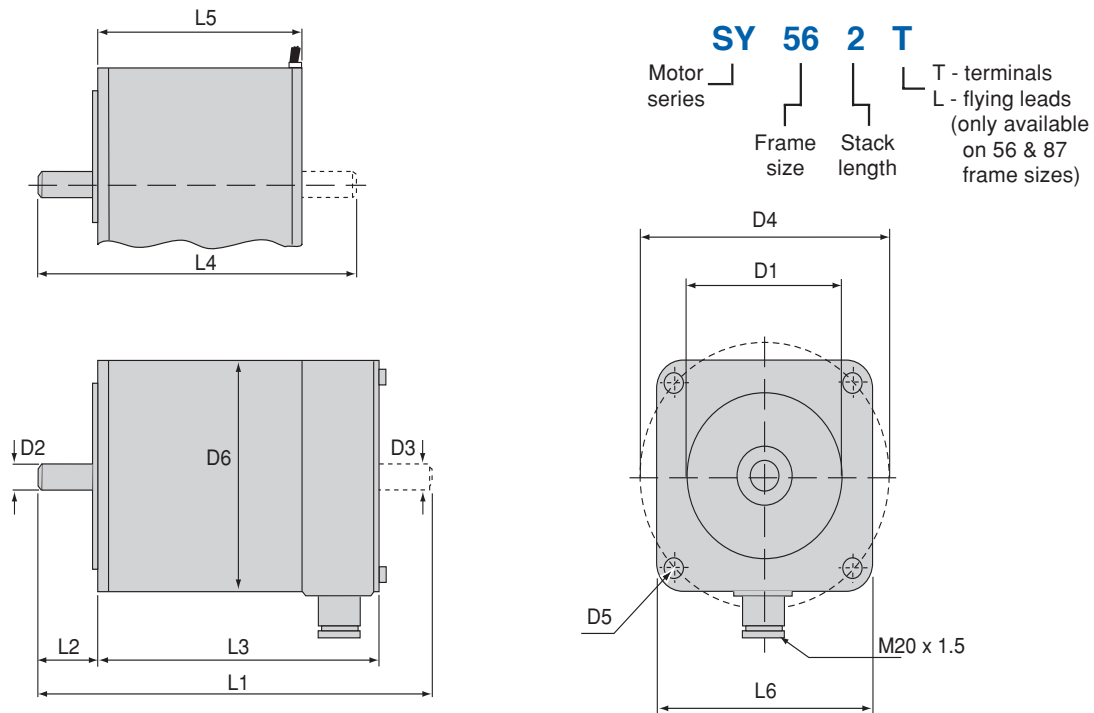

Dimensions (mm)

Series	Type	D1	D2	D3	D4	D5	D6	L1	L2	L3	L4	L5	L6
56	SY561	38.1	6.35	6.35	66.5	5.3	56.5	108	21	76	90	50	56.5
	SY562	38.1	6.35	6.35	66.5	5.3	56.5	134	21	102	116	76	56.5
	SY563	38.1	6.35	6.35	66.5	5.3	56.5	162	21	130	144	104	56.5
87	SY871	73	9.52	9.52	99	6.5	86	137	31.5	85.5	137	60.5	86
	SY872	73	9.52	9.52	99	6.5	86	169	31.5	117.5	169	92.5	86
	SY873	73	9.52	9.52	99	6.5	86	201	31.5	149.5	201	124.5	86
107	SY1072	55.54	15.87	12.7	125.5	8.5	108	238	50	161	N/A	N/A	108
	SY1073	55.54	15.87	12.7	125.5	8.5	108	288	50	211	N/A	N/A	108

Electrical & mechanical data

Part number	Maximum Holding Torque Nm	Current per phase (parallel) A (RMS)	Inductance per phase mH	Rotor inertia kgcm ²	Weight kg	Axial bearing loading N	Radial bearing loading N
SY561	0.45	4.2	1	0.125	0.6	80	150
SY562	0.85	4.2	2.6	0.25	1	80	150
SY563	1.25	6.5	1.2	0.375	1.35	80	150
SY871	1.8	4.2	1.6	0.65	1.7	180	280
SY872	3.6	6.5	1.5	1.3	2.65	180	280
SY873	5.4	8.4	1.7	1.95	3.65	180	280
SY1072	9	8	2.4	8	7.2	400	650
SY1073	13	10	2.7	12	9.8	400	650

Standard IP ratings are IP55 for screw terminal version (T) and IP41 for flying leads (L). Information on additional variants including double shaft, encoder, brake, higher IP rating and alternative windings is available on request.

Torque speed curves - XL series drives with SY motors

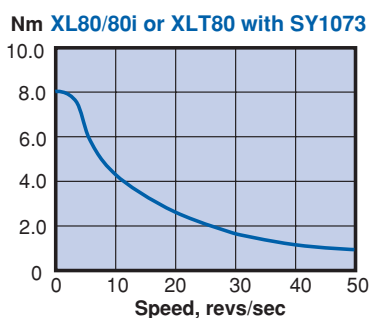
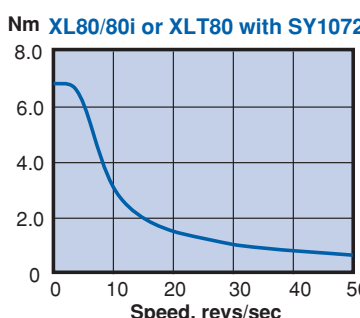
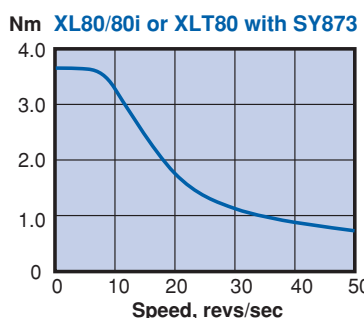
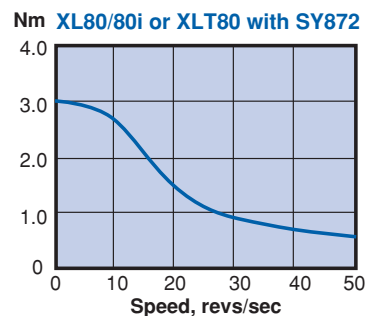
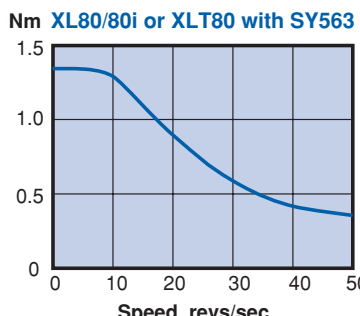
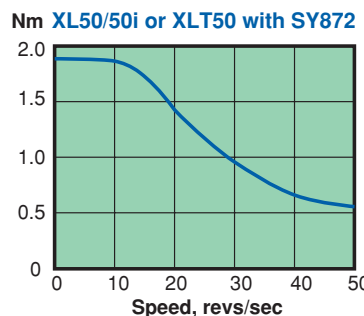
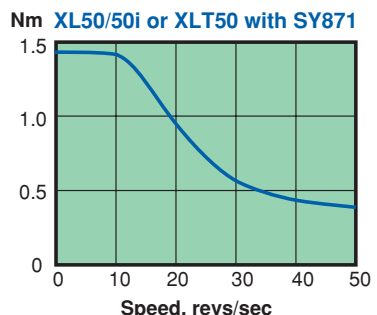
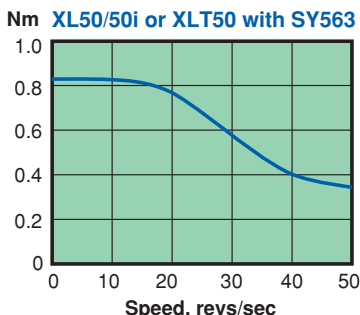
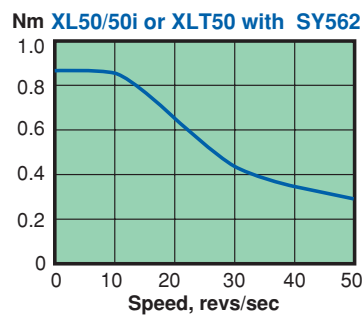
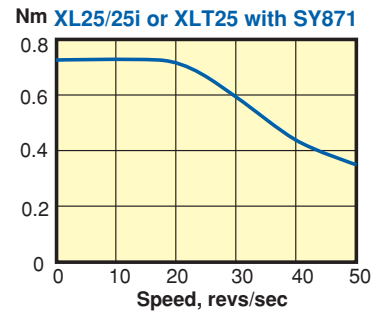
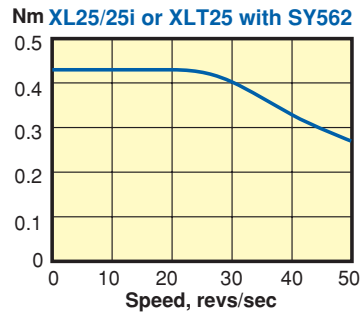
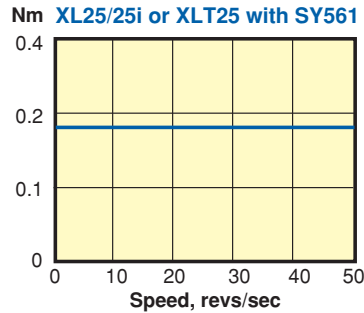

All performance measurements taken with windings in parallel

- Your partner for automation

Would you like more information?
We would be happy to send you our brochures and catalogs!
Or call us and set up a meeting.

Our product program:



Visualisation



Distributed Automation



Control Technology



Drive Technology
Servo Drives / Stepper Drives



Motors / Gears



Direct Drive Technology
Linear motors / Torque motors



Handling Actuators
Cylinders / Actuators



Precision Actuators
Screw Driven / Linear Motor Driven



Parker
Electromechanical Automation

We reserve the right to make technical changes.
The information contained in this manual corresponds to the current status at the time of printing.



Parker Hannifin GmbH & Co.KG
Electromechanical Automation
Robert-Bosch-Str. 22
D-77656 Offenburg,
Germany
☎ +49 (0)781 509 0
☎ +49 (0)781 509 98176
Website: www.parker-eme.com
e-mail: sales.hauser@parker.com

Parker Hannifin S. p. A
Electromechanical Automation
Via Gounod 1
I-20092 Cinisello Balsamo (MI),
Italy
☎ +39 0266012459
☎ +39 0266012808
Website: www.parker-eme.com
e-mail: sales.sbc@parker.com

Parker Hannifin plc
Electromechanical Automation
Arena Business Centre
Holy Rood Close, Poole, Dorset.
BH17 7BA UK
☎ +44 (0)1202 606300
☎ +44 (0)1202 606301
Website: www.parker-eme.com
e-mail: sales.digiplan@parker.com