

## 506 / 507 / 508

### DC Controller

HA389427 Issue 14  
Technical Manual

aerospace  
climate control  
electromechanical  
filtration  
fluid & gas handling  
hydraulics  
pneumatics  
process control  
sealing & shielding



ENGINEERING YOUR SUCCESS.



---

# 506/507/508

## Product Manual

HA389427 Issue 14

© Copyright 2016 Parker Hannifin Manufacturing Ltd.

All rights strictly reserved. No part of this document may be stored in a retrieval system, or transmitted in any form or by any means to persons not employed by a Parker Hannifin Manufacturing Limited without written permission from Parker Hannifin Manufacturing Ltd . Although every effort has been taken to ensure the accuracy of this document it may be necessary, without notice, to make amendments or correct omissions. Parker Hannifin Manufacturing Limited cannot accept responsibility for damage, injury, or expenses resulting therefrom.

### WARRANTY

The general terms and conditions of sale of goods and/or services of Parker Hannifin Europe Sarl, Luxembourg, Switzerland Branch, Etoy apply to this product unless otherwise agreed. The terms and conditions are available on our website [www.parker.com/termsandconditions/switzerland](http://www.parker.com/termsandconditions/switzerland)

**FAILURE OR IMPROPER SELECTION OR IMPROPER USE OF THE PRODUCTS DESCRIBED HEREIN OR RELATED ITEMS CAN CAUSE DEATH, PERSONAL INJURY AND PROPERTY DAMAGE.**

This document and other information from Parker-Hannifin Corporation, its subsidiaries and authorized distributors provide product or system options for further investigation by users having technical expertise.

The user, through its own analysis and testing, is solely responsible for making the final selection of the system and components and assuring that all performance, endurance, maintenance, safety and warning requirements of the application are met. The user must analyze all aspects of the application, follow applicable industry standards, and follow the information concerning the product in the current product catalog and in any other materials provided from Parker or its subsidiaries or authorized distributors.

To the extent that Parker or its subsidiaries or authorized distributors provide component or system options based upon data or specifications provided by the user, the user is responsible for determining that such data and specifications are suitable and sufficient for all applications and reasonably foreseeable uses of the components or systems.

*Cont-2*

# Safety Information



## Requirements

**IMPORTANT:** Please read this information **BEFORE** installing the equipment.

### Intended Users

This manual is to be made available to all persons who are required to install, configure or service equipment described herein, or any other associated operation.

The information given is intended to highlight safety issues, EMC considerations, and to enable the user to obtain maximum benefit from the equipment.

Complete the following table for future reference detailing how the unit is to be installed and used.

INSTALLATION DETAILS	
<b>Model Number</b> <i>(see product label)</i>	
<b>Where installed</b> <i>(for your own information)</i>	
<b>Unit used as a:</b> <i>(refer to Certification for the Inverter)</i>	<ul style="list-style-type: none"> <li>◆ Component</li> <li>◆ Relevant Apparatus</li> </ul>
<b>Unit fitted:</b>	<ul style="list-style-type: none"> <li>◆ Wall-mounted</li> <li>◆ Enclosure</li> </ul>



### Application Area

The equipment described is intended for industrial motor speed control utilising DC induction or DC synchronous machines.

### Personnel

Installation, operation and maintenance of the equipment should be carried out by qualified personnel. A qualified person is someone who is technically competent and familiar with all safety information and established safety practices; with the installation process, operation and maintenance of this equipment; and with all the hazards involved.

### Product Warnings

	<b>Caution</b> Risk of electric shock		<b>Caution</b> Refer to documentation		<b>Earth/Ground</b> Protective Conductor Terminal
---	--	---	--	---	--

Cont-3

## Safety Information



### Hazards

#### **DANGER! - Ignoring the following may result in injury**

1. This equipment can endanger life by exposure to rotating machinery and high voltages.
2. The equipment must be permanently earthed due to the high earth leakage current, and the drive motor must be connected to an appropriate safety earth.
3. Ensure all incoming supplies are isolated before working on the equipment. Be aware that there may be more than one supply connection to the drive.
4. There may still be dangerous voltages present at power terminals (motor output, supply input phases, DC bus and the brake, where fitted) when the motor is at standstill or is stopped.
5. For measurements use only a meter to IEC 61010 (CAT III or higher). Always begin using the highest range. CAT I and CAT II meters must not be used on this product.
6. Allow at least 5 minutes for the drive's capacitors to discharge to safe voltage levels (<50V). Use the specified meter capable of measuring up to 1000V dc & ac rms to confirm that less than 50V is present between all power terminals and earth.
7. Unless otherwise stated, this product must NOT be dismantled. In the event of a fault the drive must be returned. Refer to "Routine Maintenance and Repair".

## Safety Information



#### **WARNING! - Ignoring the following may result in injury or damage to equipment**

##### SAFETY

**Where there is conflict between EMC and Safety requirements, personnel safety shall always take precedence.**

- Never perform high voltage resistance checks on the wiring without first disconnecting the drive from the circuit being tested.
- Whilst ensuring ventilation is sufficient, provide guarding and /or additional safety systems to prevent injury or damage to equipment.
- All control and signal terminals are SELV, i.e. protected by double insulation. Ensure all external wiring is rated for the highest system voltage.
- Thermal sensors contained within the motor must have at least basic insulation.

*Cont-4*

- When replacing a drive in an application and before returning to use, it is essential that all user defined parameters for the product's operation are correctly installed.
- All exposed metalwork in the Inverter is protected by basic insulation and bonded to a safety earth.
- RCDs are not recommended for use with this product but, where their use is mandatory, only Type B RCDs should be used.

#### EMC

- In a domestic environment this product may cause radio interference in which case supplementary mitigation measures may be required.
- This equipment contains electrostatic discharge (ESD) sensitive parts. Observe static control precautions when handling, installing and servicing this product.
- This is a product of the restricted sales distribution class according to IEC 61800-3. It is designated as "professional equipment" as defined in EN61000-3-2. Permission of the supply authority shall be obtained before connection to the low voltage supply.

## Safety Information



### CAUTION!

#### APPLICATION RISK

- The specifications, processes and circuitry described herein are for guidance only and may need to be adapted to the user's specific application. We can not guarantee the suitability of the equipment described in this Manual for individual applications.

#### RISK ASSESSMENT

Under fault conditions, power loss or unintended operating conditions, the drive may not operate as intended.

In particular:

- Stored energy might not discharge to safe levels as quickly as suggested, and can still be present even though the drive appears to be switched off
- The motor's direction of rotation might not be controlled
- The motor speed might not be controlled
- The motor might be energised

A drive is a component within a drive system that may influence its operation or effects under a fault condition.

Consideration must be given to:

- Stored energy
- Supply disconnects
- Sequencing logic
- Unintended operation

Cont-5

# Contents

<i>Contents</i>	<i>Page</i>
<b>CHAPTER 1 PRODUCT OVERVIEW</b>	<b>1-1</b>
Description .....	1-1
Product Range .....	1-1
<b>CHAPTER 2 OVERVIEW OF THE 506/507/508</b>	<b>2-1</b>
<b>CHAPTER 3 TERMINAL DESCRIPTION</b>	<b>3-1</b>
Control Terminals .....	3-1
Power Terminals .....	3-2
Auxiliary Terminals .....	3-2
Switches .....	3-3
Potentiometers .....	3-3
LEDS .....	3-3
<b>CHAPTER 4 INSTALLING THE 506/507/508</b>	<b>4-1</b>
Installation .....	4-1
Speed Control .....	4-1
Current Control .....	4-1
Wire Sizes .....	4-2
Requirements for UL Compliance .....	4-3
Motor Overload Protection .....	4-3
Short Circuit Protection Requirements .....	4-3
Short Circuit Rating .....	4-3
Operating Ambient Temperature .....	4-3
Field Wiring Temperature Rating .....	4-3
Field Wiring Terminal Markings .....	4-3
Power Wiring Terminals .....	4-3
Block Diagram .....	4-4
Terminal Tightening Torque .....	4-6
Field Grounding Terminals .....	4-6
Fitting .....	4-6
Removing the Cover .....	4-7
Filter .....	4-8
EMC Connections .....	4-9
Installation and Set-Up .....	4-9
Warning .....	4-9
Switch Selection .....	4-9
Potentiometer .....	4-10
Motor .....	4-10
Wiring .....	4-10

Cont-6

# Contents

<i>Contents</i>	<i>Page</i>
Applying Power .....	4-10
Fault Finding .....	4-12
<b>CHAPTER 5 ROUTINE MAINTENANCE AND REPAIR</b>	<b>5-1</b>
Routine Maintenance .....	5-1
Repair .....	5-1
Returning the Unit to Parker Hannifin Manufacturing Limited .....	5-1
<b>CHAPTER 6 EMC CERTIFICATION FOR 506/507/508</b>	<b>6-1</b>
Certificates .....	6-1
<b>CHAPTER 7 TECHNICAL SPECIFICATIONS</b>	<b>7-1</b>
Input Supply .....	7-1
Speed Control .....	7-1
Current (Torque) Control .....	7-1
Adjustment Range .....	7-2
Environmental Requirements .....	7-2
EMC Technical Ratings .....	7-3
Electrical Ratings .....	7-4
Output Ratings with typical armature voltage, $V_a$ , 80/90V (160/180V) .....	7-4
Adjustment Ranges .....	7-4
Product Code .....	7-5

*Cont-7*

## Chapter 1 **PRODUCT OVERVIEW**

### Description

The 506/507/508 series controllers are compact, non-isolated motor speed controllers specifically designed for dc shunt wound and permanent magnet motors. The controllers are intended to operate from a single phase AC mains supply in the ranges 110/120V AC or 220/240V AC 50/60Hz.

The controllers are intended to be mounted on a length of DIN rail in an enclosure.

Control of the associated DC motor is achieved by using a linear closed loop feedback signal based on the motor's own DC armature voltage. This enables constant motor speed to be maintained throughout variable motor loads. Improved speed measurement can be obtained by using a tacho-generator, connected to the motor's shaft, to provide the feedback signal.

A current loop within the speed feedback path ensures that safe current levels are always provided to the armature of the motor up to the level set by the maximum current potentiometer (Imax). This adjustment is linear and switchable to a lower range of half the controller current.

If the controlled motor is stalled (e.g. due to either a faulty field circuit or an excessive load), then a stall timer will remove current from the motor after approximately 15 seconds. Severe armature current overloads, are protected against by an instantaneous over-current trip.

The controllers may also be used in a linear motor torque mode by using an adjustable setpoint. In this mode of operation over-speed limiting is a standard feature.

### Product Range

Product	Rating	Adjustment Standard	Switched
506	3A DC Full Load Current	0.5 to 3A	0.25 to 1.5A
507	6A DC Full Load Current	1 to 6A	0.5 to 3A
508	12A DC Full Load Current	2 to 12A	1 to 6A

*506/507/508 - HA389427*

## Chapter 2 OVERVIEW OF THE 506/507/508

Figure 2.1 Recognition Drawing

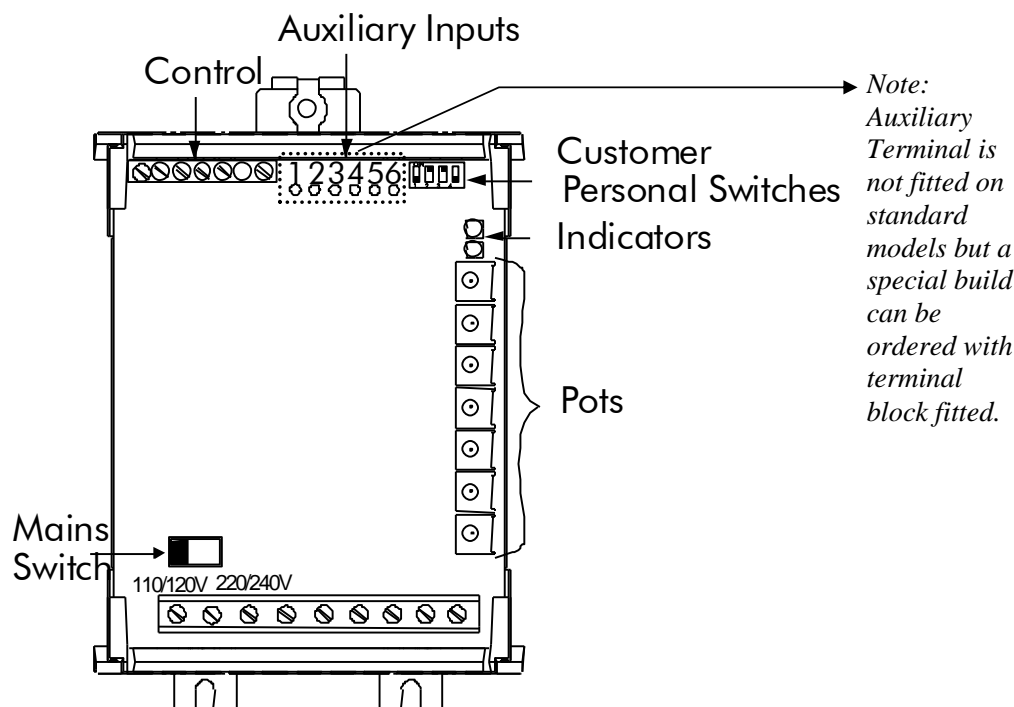

### User Supplied Safety Components

Speed /

Torque Potentiometer 10K Isolated spindle and insulating knob

Switch Rated for input supply voltage.

**Note:** Safety Components provide Isolation for the User. These components should be selected to provide a double insulated (or reinforced) isolation boards for the user suitable for the input supply voltage used. The product is designed for use in a pollution degree 2 environment, overvoltage category III, enclosure mounted. (Refer to EN61010, IEC664 or EN50178 for more information regarding the correct selection of these components).

### Optional Ancillary Components

EMC Filter 18A ac(12A dc) CO389115

506/507/508 - HA389427

### 3-1 Terminal Description

## Chapter 3 TERMINAL DESCRIPTION



Control Terminals			
Terminal	Function	Description	Notes
1	Tacho Feedback	Motor Mounted Tachogenerator Input Terminal.	200V dc Max.
2	0V-Signal Common	Control Signal Reference.	Must NOT be Earthed (Grounded).
3	Run	Digital Input to Enable Controller. Connect to 0V to Run in Speed. Connect to + 10V to Run in Current.	Input Impedance -> 20k Ohm
4	Speed Setpoint	Analogue Input, 0v to +10V = 0 to 100% Speed.	Input Impedance - 66k Ohm
5	+10V Reference	Analogue Output, +10V Reference for Speed and Current Setpoints.	Load - 2mA
6	Current Limit	Analogue Input, 0 to +10V=0 to 100% Current	Input Impedance - 100k Ohm

*Note: Auxiliary Terminal is not fitted on standard models but a special build can be ordered with terminal block fitted.*

#### WARNING!

This is a non-isolated product. The control connections are not isolated from the AC supply. Any connection to earth or use of earth (ground) referenced components either deliberately or unintentionally will cause permanent damage to the controller.

506/507/508 - HA389427

Power Terminals			
The product may be connected phase - to - phase provided the resultant voltage does not exceed the maximum supply voltage specified.			
Terminal	Function	Description	Notes
L1 (L)	AC Input Live	AC Supply Terminal Line 1 or Live	
L2 (N)	AC Input Neutral	AC Supply Terminal Line 2 or Neutral	
F+	Field Positive	Field Output Positive	
F-	Field Negative	Field Output Negative	
A-	Armature Negative	Armature Output Negative	
A+	Armature Positive	Armature Output Positive	
Grd 	Protective Earth (Ground)	Drive Module Protective Earth (Ground)	
Grd 	Protective Earth (Ground)	Motor Protective Earth (Ground)	

Auxiliary Terminals			
* The power must be supplied from an independent power supply which is not earth (ground) referenced.			
Terminal	Function	Description	Notes
A1	Auxiliary Supply	Auxiliary Relay Supply	+16V at 10mA
A2	0V - Signal Common	Signal Reference	Must not be earthed (grounded)
A3	Zero Speed	Zero Speed Output	24V at 50mA open Collector *
A4	Health	Health Output	24V at 50mA open Collector *
A5	Zero Speed Level	Zero Speed Output Level Trim	For other levels see Table 3.1
A6	Auxiliary Setpoint	Auxiliary Direct Speed Setpoint	+10V @ 100K Full Speed Input

506/507/508 - HA389427

### 3-3 Terminal Description

Table 3.1

External Resistor	Terminal Volts at Zero Speed	180Va	90Va
--	10.75V	6%	12%
4k7	5.5V	3%	6%
2k2	2.5V	2%	4%
1k	2V	1%	2%

The zero speed detector operates from the Controller Output voltage, the default level is set to 6% of 180V dc.

Switches		
Switch	Off	On
SW1	Imax. 506 - 0.25 to 1.5A Imax. 507 - 0.5 to 3.0A Imax. 508 - 1.0 to 6.0A	Imax. 506 - 0.5 to 3.0A Imax. 507 - 1.0 to 6.0A Imax. 508 - 2.0 to 12.0A
SW2	½ Speed Demand	Full Speed Demand
SW3	¼ Speed Feedback	Full Speed Feedback
SW4	Tacho Feedback	Armature Feedback

Potentiometers		
P1	RAMP UP	Setpoint ramp adjustment clockwise to increase time.
P2	RAMP DOWN	Setpoint ramp adjustment clockwise to increase time.
P3	SPEED STABILITY	Speed loop stability clockwise increase response.
P4	CURRENT CALIBRATION	Output current calibration clockwise to increase output.
P5	IR COMPENSATION	Speed droop compensation armature voltage feedback.
P6	MINIMUM SPEED	Clockwise to increase compensation. Minimum speed at zero setpoint. (Can also be used as zero speed trim anticlockwise to reduce speed at zero setpoint).
P7	MAXIMUM SPEED	Maximum speed calibration clockwise to increase speed.

LEDS	
POWER-ON	Indicates power supply is present on terminals. (Note:- This LED does not indicate that the <u>CORRECT</u> voltage is applied).
HEALTH	When illuminated the controller is unhealthy due to either an overcurrent trip or a stall trip condition. Should normally be "OFF".

506/507/508 - HA389427

## Chapter 4 INSTALLING THE 506/507/508

### Installation

#### Speed Control

Figure 4.1 Wiring Diagram Speed Control

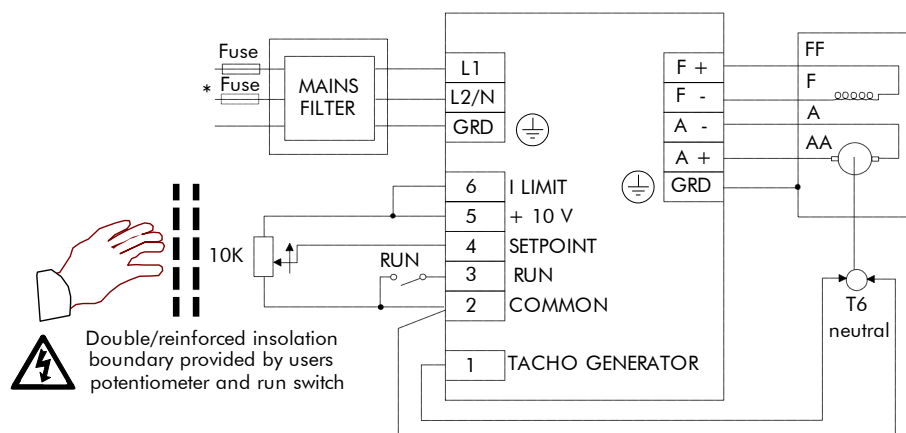

- \* Additional line fuse recommended for applications where live connections are made rather than live and neutral.

'Run' connects to Common to 'Enable' Speed Control.

#### Current Control

Figure 4.2 Wiring Diagram Current Control

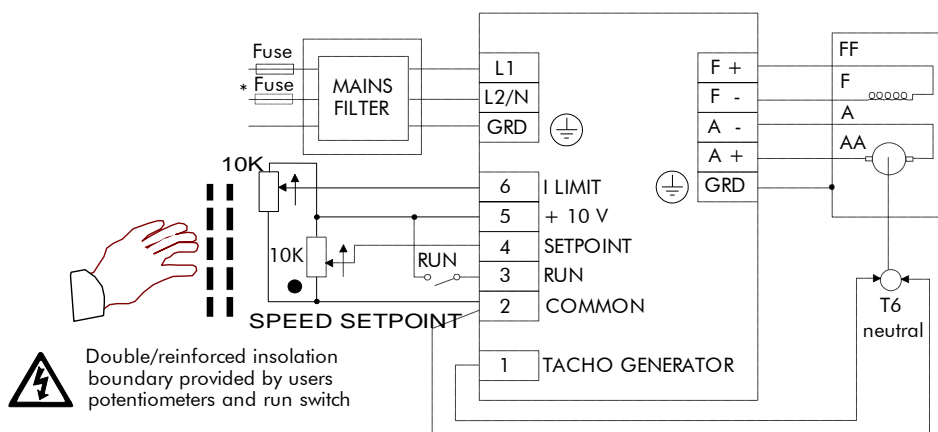

- Optional Speed Setpoint potentiometer to limit overspeed, connect setpoint direct to +10V if not required.
- \* Additional line fuse recommended for applications where live connections are made rather than live and neutral

'Run' connected to +10V to 'Enable' Current Control and 'Override' Stall detection.

506/507/508 - HA389427

## 4-2 *Installing the 506/507/508*

**WARNING!**

Ensure that all wiring is electrically isolated and cannot be made "live" unintentionally by other personnel.

### Wire Sizes

\* Contains semiconductor fuses as recommended below.

Model	Maximum Output Rating	Function	Cable (Wire) Size	AC Supply Fuse Rating	Parker Fuse Isolator Kit Part Numbers *
506	3A	DC Armature, AC Supply, Ground	1.5mm <sup>2</sup> / 16AWG	10A	LA054664
507	6A	AC Supply, Ground DC Armature	2.5mm <sup>2</sup> / 14AWG 1.5mm <sup>2</sup> / 16AWG	10A	LA054664
508	12A	AC Supply  DC Armature, Ground	6.0mm <sup>2</sup> / 10AWG 4.0mm <sup>2</sup> / 12AWG	20A	LA050062

### Terminal Tightening Torques

Terminal	Torque Setting
Power	0.8 Nm    7 lbf-in
Control	0.56 Nm    5 lbf-in

### Ferraz Semiconductor Fuses

Fuse Rating	Ferraz Type No.	Parker Part No.
10A, 250V	250VFA10A6X32	CH230014
20A, 250V	250VFA20A6X32	CH230024

506/507/508 - HA389427

## Requirements for UL Compliance

---

For installations requiring compliance with UL Standards.

### Motor Overload Protection

An external motor overload protective device must be provided by the installer. This device can comprise of a thermal sensor within the motor winding monitored by an external relay but this combination cannot be evaluated by UL. Hence, it is the responsibility of the installer/local inspector to determine whether the combination is in compliance with the National Electrical Code or local code requirements.

Motor over temperature sensing is required. Motors used in conjunction with the drive controller shall be provided with PTC sensor(s) or relays suitable for use with the variable speed drive. Technical details can be found in Chapter 4 Installing the Drive.

### Short Circuit Protection Requirements

UL Recognized semiconductor fuses must be installed upstream of the controllers. Refer to the semiconductor fuses table on the previous page for recommended semiconductor fuse manufacturer and type number.

### Short Circuit Rating

The 506 and 507 controllers are suitable for use on a circuit capable of delivering not more than 1000 RMS symmetrical amperes, 240V maximum; whilst the 508 controller is suitable for use on a circuit capable of delivering not more than 5000 rms symmetrical amperes, 240V maximum.

### Operating Ambient Temperature

The maximum operating ambient temperature rating is 40°C.

### Field Wiring Temperature Rating

Use 75°C copper conductors only.

### Field Wiring Terminal Markings

For correct field wiring connections that are to be made to each terminal, refer to Chapter 3: “Terminal Description” - Power Terminals and Control Terminals.

### Power Wiring Terminals

The power wiring terminals accept a maximum conductor size of No. 10 AWG (5.3mm<sup>2</sup>).

506/507/508 - HA389427

## Block Diagram

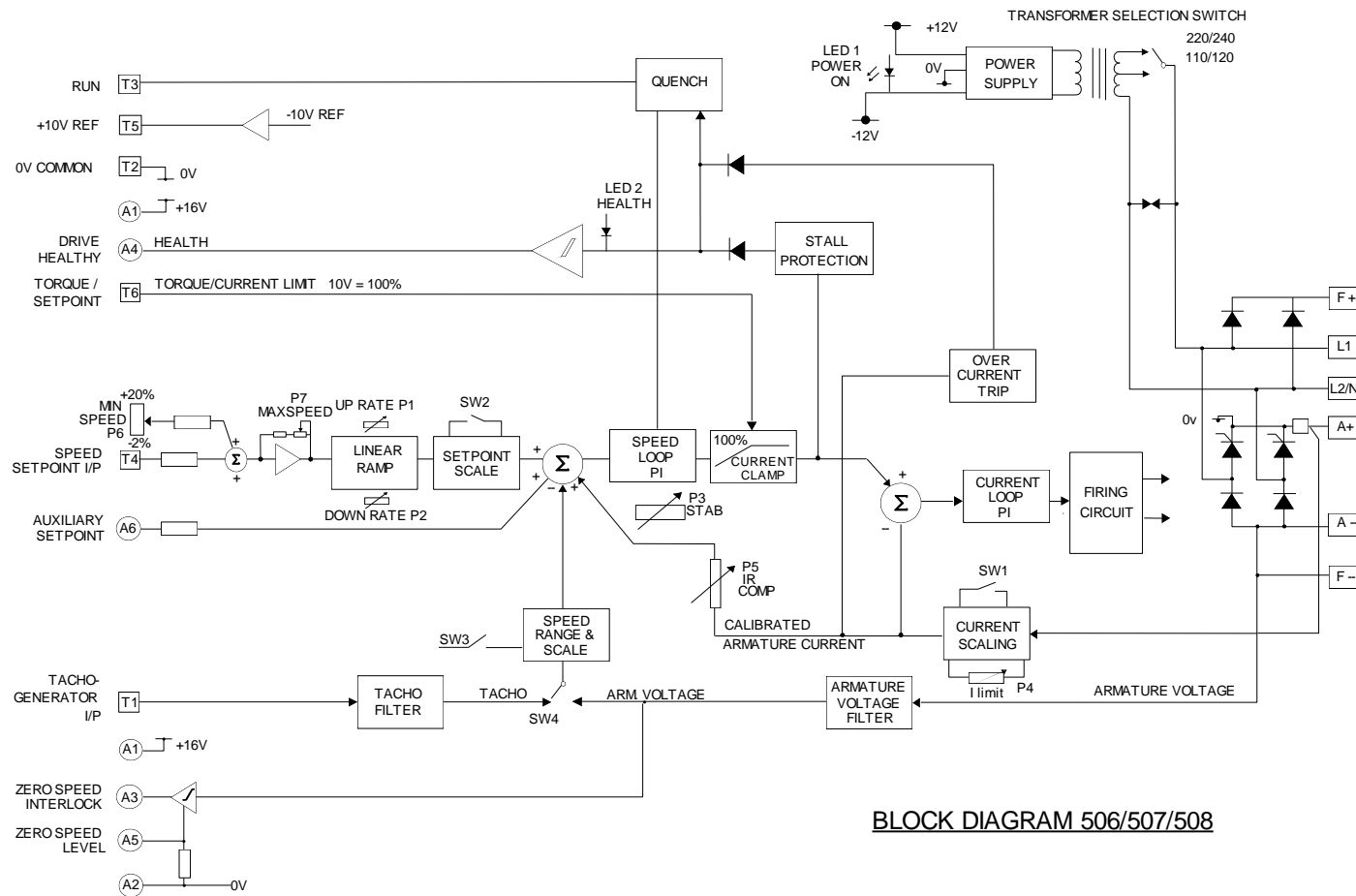

**BLOCK DIAGRAM 506/507/508**

506/507/508 - HA389427

## 4-6 *Installing the 506/507/508*

### Terminal Tightening Torque

Refer to the Terminal Tightening torque table shown on page 4-2 for both the Power and Control Terminals.

### Field Grounding Terminals

The field grounding terminals are identified with the International Grounding Symbol  $\text{⏏}$  (IEC Publication 417, Symbol 5019).

## Fitting

*Figure 4.3 Product Mechanical Arrangement*

Allow 50mm above and below product for cooling. Allow 8cm access to one side of the unit. Mount the unit with the cover in place.

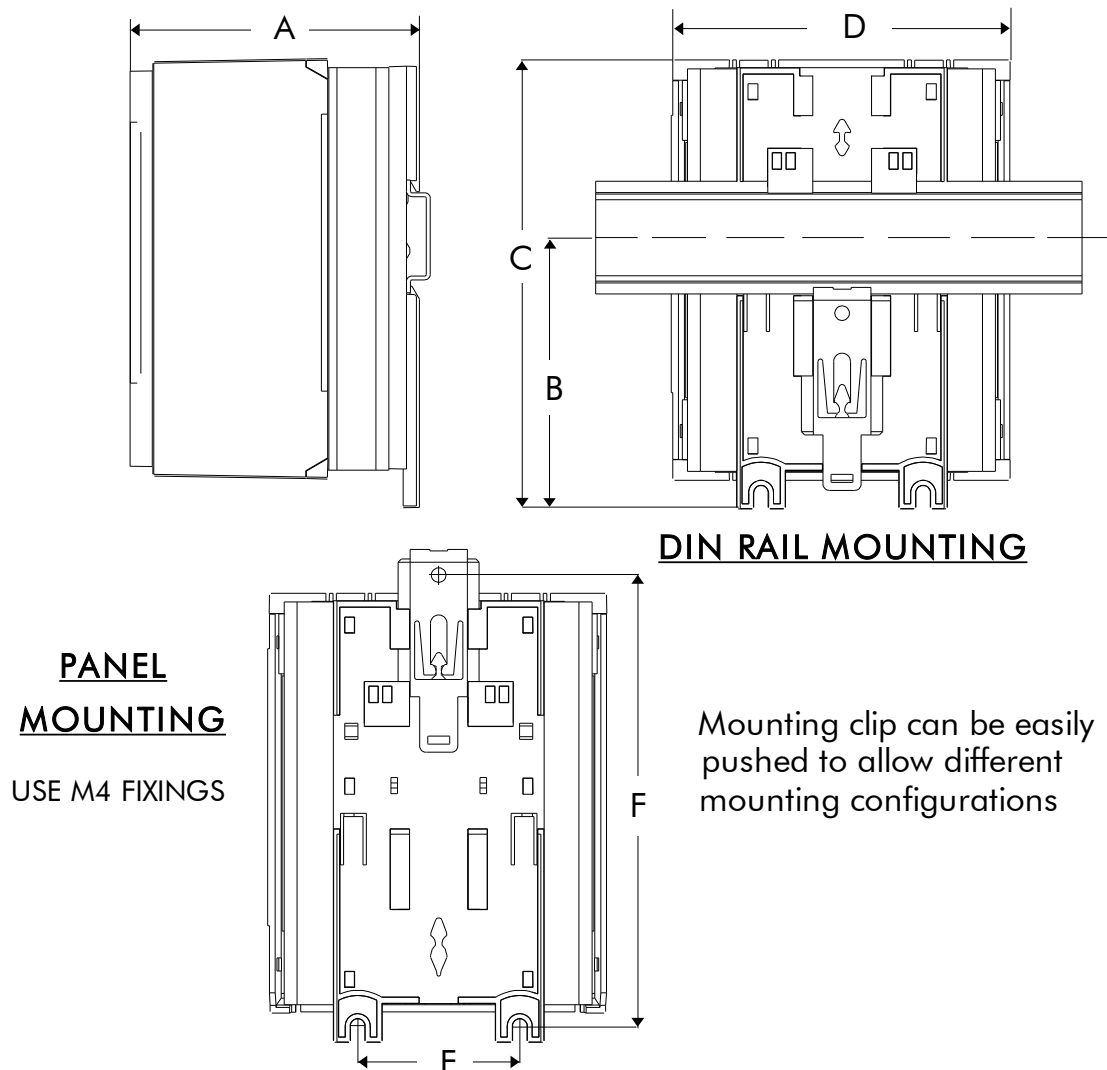

506/507/508 - HA389427

DIM	IP20		
	506	507	508
A	80 mm	80 mm	90 mm
B	84 mm	84 mm	84 mm
C	140 mm	140 mm	140 mm
D	105 mm	105 mm	105 mm
E	50 mm	50 mm	50 mm
F	140 mm	140 mm	140 mm

## Removing the Cover

**WARNING!**

Isolate the controller before fitting or removing the cover.

Remove the cover to access the terminals and switches.

It is removed easily when the unit is mounted on the backplate. There are no screw fixings. It snaps back on to the front of the drive.

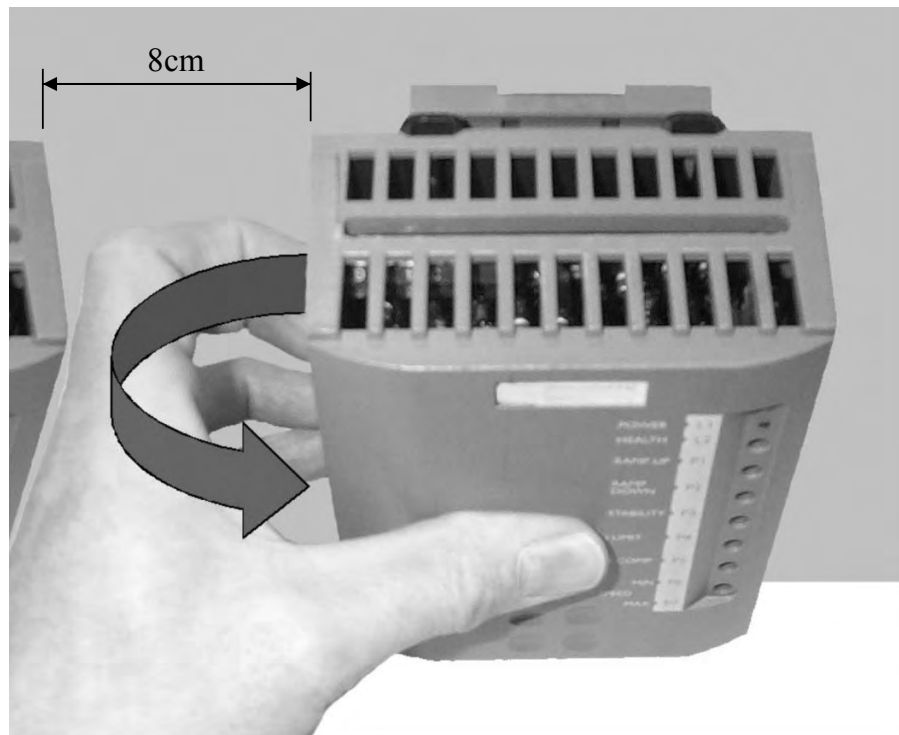

506/507/508 - HA389427

## 4-8 *Installing the 506/507/508*

### Filter

Figure 4.4 Filter Mechanical Arrangement

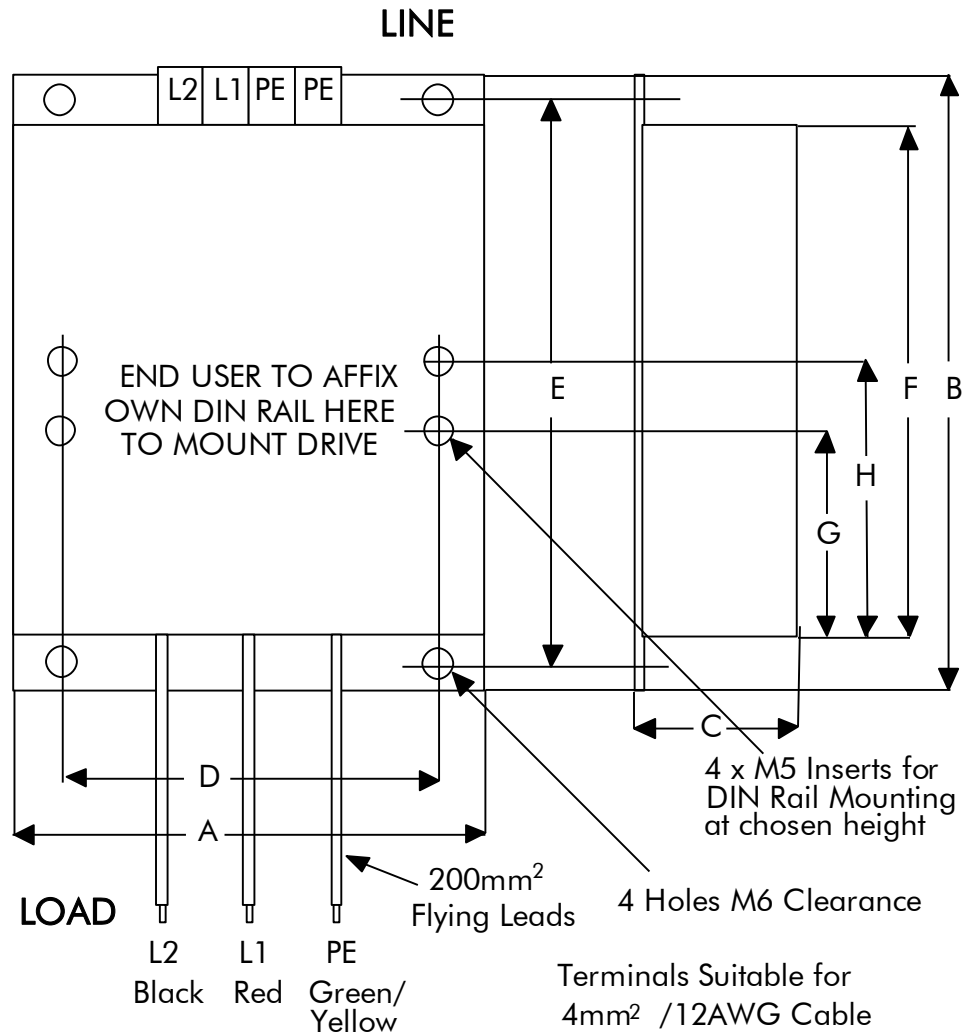

506/507/508									
Filter	Watt Loss*	Overall Dimensions			Fixing Centres				
		A	B	C	D	E	F	G	H
CO389115	9.5W	100	159	55	84	147	135	63	78

**Note:** \* Note:- Watt Loss value is at a current output of 12 Amps dc.

506/507/508 - HA389427

## EMC Connections

Figure 4.5 Wiring Diagram Mains Filter

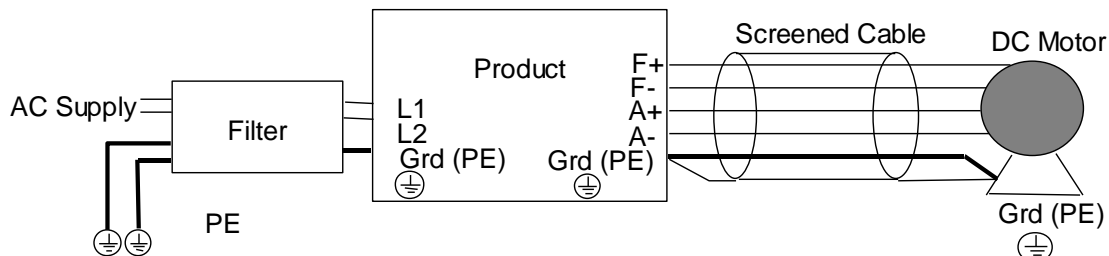

## Installation and Set-Up

### Warning

Before applying power check:-

### Switch Selection

- Mains switch set to intended supply voltage, **Left** 110/120, **Right** 220/240
- Personality switches.

SW1	OFF	ON
506	0.25 to 3A	0.5 to 3A
507	0.5 to 3A	1 to 6A
508	1 to 6A	2 to 12A

Speed	Range	Maximum Feedback Voltage Range
SW2	SW3	Armature or Tacho
OFF	OFF	15 to 30
ON	OFF	30 to 60
OFF	ON	60 to 120
ON	ON	120 to 180

SW4	OFF	ON
FEEDBACK	TACH	ARMATURE

## 4-10 *Installing the 506/507/508*

**Note:** *Even when intending to utilise tachogenerator feedback it may be wise to initially run under armature control. Set feedback voltage switches accordingly. Note that if this procedure is followed the tachogenerator must be temporarily disconnected as it will affect operation of the controller.*

### Potentiometer

(a) <b>Product</b>	<b>Default</b>
P1 Ramp Up	Anti-clockwise
P2 Ramp Down	Anti-clockwise
P3 Stability	Mid
P4 I Limit	Anti-clockwise
P5 IR Comp	Anti-clockwise
P6 Min Speed	Anti-clockwise
P7 Max Speed	Mid.

(b) **External**  
Speed setpoint to minimum.

### Motor

- (a) Check motor is compatible with controller and settings.
- (b) Check motor and load are free to rotate.

### Wiring

- (a) Check there is no loose wire ends on the PCB.
- (b) Check that there are no free wire ends on external controls liable to contact grounded metal or earth (ground) referenced parts.

## Applying Power

---

1. Power on LED 1 should illuminate.
2. Close “RUN” contact and apply a small speed setpoint (5%). Armature current should now flow, the motor should turn and run at a fixed speed.

If the motor runs above 5% up to top speed Open Run Contact.

If the controller is in “Armature” Control then excess speed is due to incorrect setting of SW2 and 3, the speed scaling.

506/507/508 - HA389427

If the controller is in “Tacho” control then excess speed is due to incorrect polarity of feedback. Alter wiring as follows:-

<b>Problem</b>	<b>Action</b>
Direction correct but overspeeding.	Reverse Tachogenerator polarity only.
Direction incorrect and overspeeding.	Reverse field polarity only.

If motor does not run, increase Ilimit potentiometer P4 as current may be insufficient for rotation. The Health light LED2 may light in this condition after 15 seconds indicating a Stall, remove and reapply power to reset condition.

If the motor is in control but runs in the wrong direction either:-

- (a) Armature Control - Reverse Field Polarity.
- (b) Tacho Control - Reverse Field AND Tacho Polarity.

3. Increase speed setpoint to maximum and check armature voltage does not exceed rated value, adjust maximum speed using P7. If a minimum speed setting is required reduce speed setpoint potentiometer to zero adjust minimum speed potentiometer P6 to give required value. With speed setpoint at maximum, re-adjust maximum speed with P7.
4. Adjust I Limit potentiometer to suit Motor Current Rating.

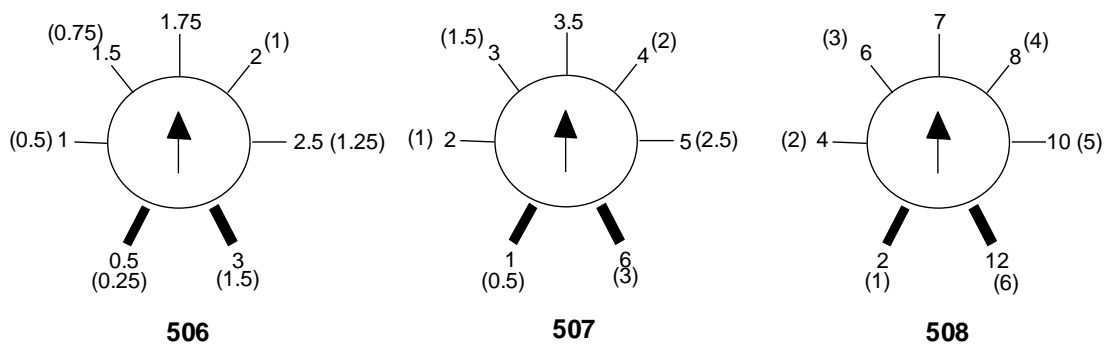

More accurate adjustment may be achieved by inserting a meter in the armature circuit.

5. Adjust Ramp Up P1 and Ramp Down P2 potentiometers as required.
6. In Armature Voltage Feedback, speed droop will occur as load is applied. Adjust IR compensation P5 to reduce this effect. Excessive adjustment may cause instability.
7. It may be necessary to adjust the Speed Stability Potentiometer P3 to improve speed response. Excessive adjustment may cause instability.

## 4-12 *Installing the 506/507/508*

### Fault Finding

Problem	Possible Cause	Remedy
Controller will not power up - no 'on' indication.	Wrong supply voltage.  Line fuses blown (if fitted).	Check setting on mains switch. It is likely that if too high a voltage has been used the Controller will be permanently damaged. Power off, check circuits and replace fuses.
Motor will not turn.	No run circuit. No setpoint.	Check run contact and wiring. Check connections to and operation of setpoint potentiometer.
Motor accelerates out of control with tacho-generator feedback and small setpoint.	Tacho polarity.  Tacho linkage. Tacho faulty.	Power off and reverse tacho connections. Check tacho coupling to motor. Remove and replace tacho.
Motor rotates in the wrong direction. Speed is controlled though.	Motor connections are wrong for required direction with: 1. Armature voltage feedback. 2. Tacho-generator feedback.	Power off and reverse armature connections. Power off and reverse <u>both</u> armature and tacho connections.
Motor will not turn and the stall light comes on after 15 seconds in speed control mode.	Motor shaft locked or jammed. No field current (not applicable for permanent magnet motors).  No armature current.  Low current limit.	Power off and check motor and load for stiffness or jamming. Check that DC voltage across motor field terminals is present. If not power off and check field circuit for continuity.  Power off and check armature circuit for continuity. Check current limit with +10V link on Controller.
Motor will only run at full speed.	Maximum speed setpoint.	Check connections to and operation of setpoint potentiometer.

506/507/508 - HA389427

Problem	Possible Cause	Remedy
Motor will not run at correct maximum speed.	Wrong speed range selection on preset switches.	Refer to Installation and Set-up chapter.
Stall light comes on after 15 seconds in current control mode.	Incorrect wiring of run contact.	Run contact should be wired between the two terminals marked 'run' and '+10V'.
Stall light comes on immediately after the 'run' contact is closed.	Faulty or incorrect load across the 'A+' and 'A-' terminals.	Check motor armature thoroughly. The Controller should not be used on motors with a low inductance.

## 5-1 *Routine Maintenance & Repair*

# Chapter 5 ROUTINE MAINTENANCE AND REPAIR

## Routine Maintenance

---

Periodically inspect the motor speed controller for build-up of dust or obstructions that may affect ventilation of the unit. Remove this using dry air.

## Repair

---

There are no user-serviceable components.

**IMPORTANT:** MAKE NO ATTEMPT TO REPAIR THE UNIT - RETURN IT TO PARKER HANNIFIN MANUFACTURING LIMITED.

## Returning the Unit to Parker Hannifin Manufacturing Limited

Please have the following information available:

- The model and serial number - see the unit's rating label
- Details of the fault

Contact your nearest Parker Hannifin Manufacturing Limited Service Centre to arrange return of the item.

You will be given a *Returned Material Authorisation*. Use this as a reference on all paperwork you return with the faulty item. Pack and despatch the item in the original packing materials; or at least an antistatic enclosure. Do not allow packaging chips to enter the unit.

506/507/508 - HA389427

# Chapter 6 EMC CERTIFICATION FOR 506/507/508

## Certificates

Issued for compliance with the EMC Directive when the unit is used as *relevant apparatus*.

This is provided to aid your justification for EMC compliance when the unit is used as a *component*.

The drive is CE marked in accordance with the low voltage directive for electrical equipment and appliances in the voltage range when installed correctly.

Since the potential hazards are mainly electrical rather than mechanical, the drive does not fall under the machinery directive. However, we do supply a manufacturer's declaration for when the drive is used (as a *component*) in machinery.

506/507/508	
<div style="display: flex; justify-content: space-between; align-items: center;"> <div style="font-size: 2em; font-weight: bold;">CE</div> <div> <h3 style="margin: 0;">EU DECLARATIONS OF CONFORMITY</h3> <p style="font-size: 0.8em; margin: 0;">Date CE marked first applied: 01.04.2000</p> </div> </div>	
<div style="text-align: center; background-color: black; color: white; padding: 5px; margin-bottom: 10px;"><b>EMC Directive</b></div> <p style="text-align: center; font-size: 0.8em;">In accordance with the EU Directive 2014/30/EU</p> <p style="font-size: 0.8em;">We Parker Hannifin Manufacturing Limited, address as below, declare under our sole responsibility that the above Electronic Products when installed and operated with reference to the instructions in the Product Manual (provided with each piece of equipment) is in accordance with the relevant clauses from the following standard:-</p> <p style="text-align: center; font-size: 0.8em;">* BSEN61800-3 (2004)</p>	<div style="text-align: center; background-color: black; color: white; padding: 5px; margin-bottom: 10px;"><b>Low Voltage Directive</b></div> <p style="text-align: center; font-size: 0.8em;">In accordance with the EU Directive 2014/35/EU</p> <p style="font-size: 0.8em;">We Parker Hannifin Manufacturing Limited, address as below, declare under our sole responsibility that the above Electronic Products when installed and operated with reference to the instructions in the Product Manual (provided with each piece of equipment), is in accordance with the relevant clauses from the following standard :-</p> <p style="text-align: center; font-size: 0.8em;">EN50178 (1998)</p>
<h3 style="margin: 0;">MANUFACTURERS DECLARATIONS</h3>	
<div style="text-align: center; background-color: black; color: white; padding: 5px; margin-bottom: 10px;"><b>EMC Declaration</b></div> <p style="font-size: 0.8em;">We Parker Hannifin Manufacturing Limited, address as below, declare under our sole responsibility that the above Electronic Products when installed and operated with reference to the instructions in the Product Manual (provided with each piece of equipment) is in accordance with the relevant clauses from the following standard:-</p> <p style="text-align: center; font-size: 0.8em;">* BSEN61800-3 (2004)</p>	<div style="text-align: center; background-color: black; color: white; padding: 5px; margin-bottom: 10px;"><b>Machinery Directive</b></div> <p style="font-size: 0.8em;">The above Electronic Products are components to be incorporated into machinery and may not be operated alone. The complete machinery or installation using this equipment may only be put into service when the safety considerations of the Directive 2006/42/EC are fully adhered to. Particular reference should be made to EN60204-1 (Safety of Machinery - Electrical Equipment of Machines). All instructions, warnings and safety information of the Product Manual must be adhered to.</p>
<div style="display: flex; justify-content: center; align-items: center; gap: 20px;">  <div> <p>Date 01 June 2016</p> <p><b>Dr Martin Payn</b> EME Division Engineering Manager</p> </div> </div> <p style="font-size: 0.8em; margin-top: 10px;">* Compliant with the immunity requirements of the Standard without specified EMC filters.</p> <p style="font-size: 0.8em; margin-top: 10px;">                     Parker Hannifin Manufacturing Limited, Automation Group,                      Electromechanical Drives Business Unit,                      NEW COURTWICK LANE, LITTLEHAMPTON, WEST SUSSEX BN17 7RZ                      TELEPHONE: +44(0)1903 737000 FAX: +44(0)1903 737100                      Registered Number: 4806503 England. Registered Office: 55 Maylands Avenue, Hemel Hempstead, Herts HP2 4SJ                 </p>	

506/507/508 - HA389427

## Chapter 7 TECHNICAL SPECIFICATIONS

Input Supply			
Parameter	Symbol	Value	Units
Frequency		50/60 ± 10%	Hz
Voltage	V <sub>s</sub>	110/120 ± 10% or 220/240 ± 10% (Earth (TN) or non-earth (IT) referenced)	V

Speed Control			
<p>(1) Range selected by built in switches.</p> <p>(2) With IR comp setting optimised.</p> <p>(3) Consideration must be given to the motor at it may overheat at low speed.</p>			
Parameter	Symbol	Value	Units
Stall detect time		15 maximum 20 typical	s
Type of controller		Variable proportional plus integral	
Feedback method <sup>(1)</sup>		V <sub>a</sub> Tacho	
0-100% load regulation		2 <sup>(2)</sup> (typically)      0.1 (typically)	
Max. torque speed range		20:1                      100:1 <sup>(3)</sup>	%

Current (Torque) Control			
<p>(1) Range selected by built in switches.</p> <p>(2) Suitable for armature time constants not less than 5ms.</p> <p>(3) <b>All control terminals are at a potential of the peak of the input supply with respect to earth (ground) <math>\oplus</math>.</b></p> <p><b>All cables should be rated for this voltage.</b></p>			
Parameter	Symbol	Value	Units
Overspeed limiting <sup>(1)</sup>		Standard <sup>(1)</sup>	
Type of controller <sup>(2)</sup>		Fixed proportional plus integral	
Feedback method		Non-isolated shunt <sup>(3)</sup>	
Linearity		2	%

506/507/508 - HA389427

<b>Adjustment Range</b>			
Parameter	Symbol	Value	Units
Armature loss comp.	IR comp	0 - 25% of $V_a$	
Maximum speed	N max	100% $\pm$ 25%	
Minimum speed	N min	0 - 25% of N max	%
Ramp up time	Ramp	1 - 15 (minimum)	s
Ramp down time	Ramp	1 - 15 (minimum)	s

<b>Environmental Requirements</b>	
Operating Temperature	0 to +40°C (Derate 1.5% / Degree above 40°C)
Max. Operating Temperature	50°C
Humidity	85% R.H. at 40°C (non condensing)
Altitude	Above 1000m derate at 1% / 100m to a maximum of 2000m
Atmosphere	Non-flammable, non-corrosive and dust free
Storage Temperature Range	-25°C to +55°C
Transport Temperature Range	-25°C to +55°C
Enclosure	IP2X suitable for cubicle mounting
Installation Category	Overvoltage Category III.
Pollution	Pollution Degree 2.

506/507/508 - HA389427

## 7-3 *Technical Specifications*

EMC Technical Ratings					
Immunity					
Port	Phenomenon	Test Standard	Level	Criterion	Generic Standard
Enclosure Port	ESD RF Field	BS EN61000-4-2(1995)	8kV AD 10V/m, 1kHz AM	Self Recovery No Change	EN50082 -1 (1992), and EN50082 -2 (1995)
Power Ports	Fast Transient Burst	BS EN61000-4-4(1995)	2kV	Self Recovery	
Signal & Control	Fast Transient Burst	BS EN61000-4-4(1995)	2kV	Self Recovery	
Power Interfaces	Fast Transient Burst	BS EN61000-4-4(1995)	2kV	Self Recovery	

Emissions				
<p>These levels of performance are achieved when installed as specified with the recommended Supply Filter.</p> <p>* Achieved with up to 50m of motor cable.</p>				
Port	Phenomenon	Test Standard	Level	Generic Standard
Enclosure Port	Radiated	EN55011	Class B	EN50081-1 (1992)
Power Port	Conducted	EN55011	Class B*	EN50081-2 (1994)

506/507/508 - HA389427

## Electrical Ratings

### Output Ratings with typical armature voltage, $V_a$ , 80/90V (160/180V)

- (1) Range selected by built in switches.
- (2) When the controller is energised the dc motor shunt field is permanently energised. It is the responsibility of the installer to ensure that this is not detrimental to the long term reliability of the dc motor.

Parameter	506		507		508	
Maximum Armature Output Current (IA) <sup>(1)</sup>	1.5A	3A	3A	6A	6A	12A
Typical Motor Horsepower (Hp)						
90V Armature (110/120V AC)	1/10	1/6	1/6	1/3	1/3	3/4
180V Armature (220/240V AC)	1/6	1/3	1/3	3/4	3/4	2
Typical Motor Power (kW)						
90V Armature (110/120V AC)	0.07	0.125	0.125	0.25	0.25	0.55
180V Armature (220/240V AC)	0.125	0.25	0.25	0.55	0.55	1.5
Controller loss (W)	5	10	10	20	20	40
Maximum AC Supply Current (Is,A rms)	3	4.5	6	9	12	18
Maximum I <sup>2</sup> t for fusing (A <sup>2</sup> s)	36	36	80	80	365	365
Maximum form factor (Is/Ia)	2	1.5	2	1.5	2	1.5
Maximum Field Current <sup>(2)</sup> (If, A dc)	2					
Field Voltage (0.9 x Vs) V dc	V					
110/120V AC	90-100					
220/240V AC	180-200					

### Adjustment Ranges

- \* Range selected by built in switches.

Parameter	506	507	508
Maximum current * (I max, A)	0.25 - 3	0.5 - 6	1 - 12

506/507/508 - HA389427

## 7-5 *Technical Specifications*

Product Code			
Block	Product	Code	Feature
1	Basic Product	506	3 Amp
		507	6 Amp
		508	12 Amp
2	Livery	00	Standard
		01 to 99	Customer
3	Cover	20	IP20 Cover
4	Special Options	00	Standard
		01 to 99	Documented Special Options

506/507/508 - HA389427

## Parker Worldwide

**AE – UAE, Dubai**

Tel: +971 4 8127100  
parker.me@parker.com

**AR – Argentina, Buenos Aires**

Tel: +54 3327 44 4129

**AT – Austria, Wiener Neustadt**

Tel: +43 (0)2622 23501-0  
parker.austria@parker.com

**AT – Eastern Europe, Wiener Neustadt**

Tel: +43 (0)2622 23501 900  
parker.eastereurope@parker.com

**AU – Australia, Castle Hill**

Tel: +61 (0)2-9634 7777

**AZ – Azerbaijan, Baku**

Tel: +994 50 2233 458  
parker.azerbaijan@parker.com

**BE/LU – Belgium, Nivelles**

Tel: +32 (0)67 280 900  
parker.belgium@parker.com

**BR – Brazil, Cachoeirinha RS**

Tel: +55 51 3470 9144

**BY – Belarus, Minsk**

Tel: +375 17 209 9399  
parker.belarus@parker.com

**CA – Canada, Milton, Ontario**

Tel: +1 905 693 3000

**CH – Switzerland, Etoy**

Tel: +41 (0)21 821 87 00  
parker.switzerland@parker.com

**CL – Chile, Santiago**

Tel: +56 2 623 1216

**CN – China, Shanghai**

Tel: +86 21 2899 5000

**CZ – Czech Republic, Klecany**

Tel: +420 284 083 111  
parker.czechrepublic@parker.com

**DE – Germany, Kaarst**

Tel: +49 (0)2131 4016 0  
parker.germany@parker.com

**DK – Denmark, Ballerup**

Tel: +45 43 56 04 00  
parker.denmark@parker.com

**ES – Spain, Madrid**

Tel: +34 902 330 001  
parker.spain@parker.com

**FI – Finland, Vantaa**

Tel: +358 (0)20 753 2500  
parker.finland@parker.com

**FR – France, Contamine s/Arve**

Tel: +33 (0)4 50 25 80 25  
parker.france@parker.com

**GR – Greece, Athens**

Tel: +30 210 933 6450  
parker.greece@parker.com

**HK – Hong Kong**

Tel: +852 2428 8008

**HU – Hungary, Budapest**

Tel: +36 1 220 4155  
parker.hungary@parker.com

**IE – Ireland, Dublin**

Tel: +353 (0)1 466 6370  
parker.ireland@parker.com

**IN – India, Mumbai**

Tel: +91 22 6513 7081-85

**IT – Italy, Corsico (MI)**

Tel: +39 02 45 19 21  
parker.italy@parker.com

**JP – Japan, Tokyo**

Tel: +81 (0)3 6408 3901

**KR – South Korea, Seoul**

Tel: +82 2 559 0400

**KZ – Kazakhstan, Almaty**

Tel: +7 7272 505 800  
parker.eastereurope@parker.com

**MX – Mexico, Apodaca**

Tel: +52 81 8156 6000

**MY – Malaysia, Shah Alam**

Tel: +60 3 7849 0800

**NL – The Netherlands, Oldenzaal**

Tel: +31 (0)541 585 000  
parker.nl@parker.com

**NO – Norway, Asker**

Tel: +47 66 75 34 00  
parker.norway@parker.com

**NZ – New Zealand, Mt Wellington**

Tel: +64 9 574 1744

**PL – Poland, Warsaw**

Tel: +48 (0)22 573 24 00  
parker.poland@parker.com

**PT – Portugal, Leca da Palmeira**

Tel: +351 22 999 7360  
parker.portugal@parker.com

**RO – Romania, Bucharest**

Tel: +40 21 252 1382  
parker.romania@parker.com

**RU – Russia, Moscow**

Tel: +7 495 645-2156  
parker.russia@parker.com

**SE – Sweden, Spånga**

Tel: +46 (0)8 59 79 50 00  
parker.sweden@parker.com

**SG – Singapore**

Tel: +65 6887 6300

**SK – Slovakia, Banská Bystrica**

Tel: +421 484 162 252  
parker.slovakia@parker.com

**SL – Slovenia, Novo Mesto**

Tel: +386 7 337 6650  
parker.slovenia@parker.com

**TH – Thailand, Bangkok**

Tel: +662 717 8140

**TR – Turkey, Istanbul**

Tel: +90 216 4997081  
parker.turkey@parker.com

**TW – Taiwan, Taipei**

Tel: +886 2 2298 8987

**UA – Ukraine, Kiev**

Tel: +380 44 494 2731  
parker.ukraine@parker.com

**UK – United Kingdom, Warwick**

Tel: +44 (0)1926 317 878  
parker.uk@parker.com

**US – USA, Cleveland**

Tel: +1 216 896 3000

**VE – Venezuela, Caracas**

Tel: +58 212 238 5422

**ZA – South Africa, Kempton Park**

Tel: +27 (0)11 961 0700  
parker.southafrica@parker.com

**European Product Information Centre**

Free phone: 00 800 27 27 5374

(from AT, BE, CH, CZ, DE, EE, ES, FI, FR, IE, IL, IS, IT, LU, MT, NL, NO, PT, SE, SK, UK)

© 2016 Parker Hannifin Corporation. All rights reserved.

Parker Hannifin Manufacturing Limited,  
Automation Group,  
Electromechanical Drives Business Unit,  
New Courtwick Lane, Littlehampton,  
West Sussex BN17 7RZ  
United Kingdom  
Tel: +44(0)1903 737000  
Fax: +44(0)1903 737100



\* H A S B R 9 4 2 7 - 1 4 \*