



Modular Electric Actuators OSP-E

ORIGA SYSTEM PLUS

aerospace
climate control
electromechanical
filtration
fluid & gas handling
hydraulics
pneumatics
process control
sealing & shielding



ENGINEERING YOUR SUCCESS.

OSP Concept

Origa System Plus

Electric Actuator OSP-E, Modular Components - Overview	4
Applications for OSP-E Actuators	8

Belt Actuator

OSP-E..BHD, Belt Actuator with Integrated Guide	11
— Ball Bearing Guide	15
— Roller Guide	20
OSP-E..BV, Vertical Belt Actuator with Integrated Ball Bearing Guide	27
OSP-E..B, Belt Actuator with Internal Plain Bearing Guide	39

Screw Actuator

OSP-E..SB, Ball Screw Actuator with Internal Plain Bearing Guide	53
OSP-E..ST, Trapezoidal Screw Actuator with Internal Plain Bearing Guide	67
OSP-E..SBR, Ball Screw Aktuator with Internal Plain Bearing Guide and Piston Rod	79
OSP-E..STR, Trapezoidal Screw Actuator with Internal Plain Bearing Guide and Piston Rod	89

Linear Guides

SLIDELINE - Plain Bearing Guide	101
POWERSLIDE - Roller Guide	103
PROLINE - Aluminium Roller Guide	107
HD - Heavy-duty Guide	111

Gears

PS/RS - Planetary / Angular Gears	115
-----------------------------------	-----

Motor and Drives

EasyDrive Packages	121
--------------------	-----

Accessories

Motor Mounting	133
End Cap Mounting	141
Profile Mounting	147
Compensation	155
Guide Mounting	161
Magnetic Sensors	165
Measuring System - SFI-plus	171
Cable Cover	175

Multi Axis Connections

Overview	178
Adapter Plate	181
Intermediate Drive Shaft	190

The right to introduce technical modifications is reserved

ORIGA SYSTEM PLUS

– One Concept

– Three Actuator Options

Based on the concept of the rodless pneumatic cylinder, well proven worldwide, Parker now offers the complete solution for actuator systems. Developed for absolute reliability, high performance, easy handling and optimized design, ORIGA SYSTEM PLUS can master even the most difficult installation requirements.

ORIGA SYSTEM PLUS

is a completely modular concept, enabling pneumatic and electric actuators to be combined with guides and control modules for all kinds of applications. The main system carriers are the actuators themselves, consisting of extruded aluminium profiles with

double dovetail slots on three sides, providing direct mounting for all modular options.



MODULAR SYSTEM

- **Electric Belt Actuator**

- For applications with higher speeds and precise movement and positioning for longer travel.

- **Electric Screw Actuator**

- For higher actuator power and precise movement and positioning.

- **Pneumatic Actuator**

- For a wide variety of applications with simple handling, combined with simple control possibilities and a broad power spectrum
- Ideal for fast, repetitive movements and simple positioning duties.

- 18 additional guide variants provide any required precision, performance and load capacity.

- Compact solutions, easy to install and simple to retrofit.

- Valves and control elements can be mounted directly on the pneumatic actuator.

























- A wide range of mounting options provides great installation flexibility.

For further information see the Pneumatic Actuators Catalogue P-A4P011GB.



ORIGA SYSTEM PLUS
– One Concept
– Three Actuator Options

* Information on Pneumatic Actuators, see catalogue P-A4P011GB

<p>Basic Linear Drive Standard Version</p> <ul style="list-style-type: none"> • Series OSP-P* • Series OSP-E Belt Drive Belt Drive with Integrated Guides Vertical Belt Drive with Recirculating Ball Bearing Guide • Series OSP-E Screw Drive (Ball Screw, Trapezoidal Screw) 	<p>Multi-Axis Systems Connecting Elements</p> <ul style="list-style-type: none"> • Adapter Plates • Intermediate Drive Shafts 
<p>Air Connection on the End-face or Both at One End</p> <ul style="list-style-type: none"> • Series OSP-P* 	<p>Duplex-Connection</p> <ul style="list-style-type: none"> • Series OSP-P* 
<p>Clean Room Cylinders certified to DIN EN ISO 146644-1</p> <ul style="list-style-type: none"> • Series OSP-P* • Series OSP-E..SB 	<p>Multiplex-Connection</p> <ul style="list-style-type: none"> • Series OSP-P* 
<p>Products in ATEX-Version</p> <ul style="list-style-type: none"> • Series OSP-P* Rodless Cylinder  	<p>Linear Guides - SLIDELINE</p> <ul style="list-style-type: none"> • Series OSP-P* • Series OSP-E Screw 
<p>Products in ATEX-Version</p> <ul style="list-style-type: none"> • Series OSP-P* Rodless Cylinders with Plain Bearing SLIDELINE  	<p>Linear Guides - POWERSLIDE</p> <ul style="list-style-type: none"> • Series OSP-P* • Series OSP-E Belt • Series OSP-E Screw 
<p>Cylinders for Synchronised Counter-Rotation of the Cylinders</p> <ul style="list-style-type: none"> • Series OSP-P* 	<p>Linear Guides - PROLINE</p> <ul style="list-style-type: none"> • Series OSP-P* • Series OSP-E Belt • Series OSP-E Screw 
<p>Integrated 3/2-Way Valves</p> <ul style="list-style-type: none"> • Series OSP-P* 	<p>Linear Guides - STARLINE</p> <ul style="list-style-type: none"> • Series OSP-P* <p>Linear Guides - KF</p> <ul style="list-style-type: none"> • Series OSP-P* 
<p>Compensation</p> <ul style="list-style-type: none"> • Series OSP-P* • Series OSP-E Belt • Series OSP-E Screw 	<p>Heavy Duty-Guides HD</p> <ul style="list-style-type: none"> • Series OSP-P* • Series OSP-E Screw 
<p>End Cap Mounting</p> <ul style="list-style-type: none"> • Series OSP-P* • Series OSP-E Belt • Series OSP-E Screw 	<p>Brakes</p> <ul style="list-style-type: none"> • Active Brakes* • Passive Brakes* 
<p>Profile Mounting</p> <ul style="list-style-type: none"> • Series OSP-P* • Series OSP-E Belt • Series OSP-E Screw 	<p>Planetary Gears PV</p> <ul style="list-style-type: none"> • Series OSP-E Belt* • Series OSP-E Screw 
<p>Inversion Mounting</p> <ul style="list-style-type: none"> • Series OSP-P* • Series OSP-E Belt • Series OSP-E Screw 	<p>Magnetic Sensor</p> <ul style="list-style-type: none"> • Series OSP-P* • Series OSP-E Belt • Series OSP-E Screw  <p>SFI-plus Displacement Measuring Systems</p> <ul style="list-style-type: none"> • Series OSP-P* • Series OSP-E Screw 

Actuators	OSP-E20 -BHD ¹⁾	OSP-E25 -BHD ^{1, 2)}	OSP-E32 -BHD ^{1, 2)}	OSP-E50 -BHD ^{1, 2)}	OSP-E20 -BV ³⁾	OSP-E25 -BV ³⁾	OSP-E25 -B ⁴⁾	OSP-E32 -B ⁴⁾	OSP-E50 -B ⁴⁾	OSP-E25 -SB ⁵⁾	OSP-E32 -SB ⁵⁾
Effective Action Force F_A [N]	450 - 550	550 - 1070	1030 - 1870	1940 - 3120	450 - 650	1050 - 1490	50	100 - 150	300 - 425	250	600
Max. Velocity v [m/s]	3.0	10.0 / 5	10.0 / 5	10.0 / 5	3.0	5.0	2.0	3.0	5.0	0.25	0.5
Integrated Magnets	□	□	□	□	-	-	□	□	□	□	□
Free Choice of Stroke Length [mm] **	1 - 5760	1 - 7000	1 - 7000	1 - 7000	1 - 1000	1 - 1500	1 - 3000	1 - 5000	1 - 5000	1 - 1100	1 - 2000
Temperature Range [°C]	-30 - +80	-30 - +80	-30 - +80	-30 - +80	-30 - +80	-30 - +80	-30 - +80	-30 - +80	-30 - +80	-20 - +80	-20 - +80
Tandem Version	0	0	0	0	0	0	0	0	0	0	0
Bi-parting Version	0	0	0	0	-	-	0	0	0	0	0
Stainless Steel Parts	X	X	X	X	X	X	0	0	0	X	X
Integrated Planetary Gearbox LPB***	-	0	0	0	-	-	-	-	-	-	-
Self Guidance											
F [N]	1600	3000 / 986	10000 / 1348	15000 / 3704	1600	3000	160	300	850	500	1200
M_x [Nm]	21	50 / 11	120 / 19	180 / 87	20	50	2	8	16	2	8
M_y [Nm]	150	500 / 64	1000 / 115	1800 / 365	100	200	12	25	80	12	25
M_z [Nm]	150	500 / 64	1400 / 115	2500 / 365	100	200	8	16	32	8	16
Slideline											
F [N]	-	-	-	-	-	-	-	-	-	675	925
M_x [Nm]	-	-	-	-	-	-	-	-	-	14	29
M_y [Nm]	-	-	-	-	-	-	-	-	-	34	60
M_z [Nm]	-	-	-	-	-	-	-	-	-	34	60
Proline											
F [N]	-	-	-	-	-	-	986	1348	3582	986	1348
M_x [Nm]	-	-	-	-	-	-	19	33	128	19	33
M_y [Nm]	-	-	-	-	-	-	44	84	287	44	84
M_z [Nm]	-	-	-	-	-	-	44	84	287	44	84
Powerslide											
F [N]	-	-	-	-	-	-	910 - 1190	1400 - 2300	3000 - 4000	910-1190	1400-2300
M_x [Nm]	-	-	-	-	-	-	14 - 20	20 - 50	90 - 140	14-20	20-50
M_y [Nm]	-	-	-	-	-	-	63 - 175	70 - 175	250 - 350	63-175	70-175
M_z [Nm]	-	-	-	-	-	-	63 - 175	70 - 175	250 - 350	63-175	70-175
HD-Guide (Heavy Duty)											
F [N]	-	-	-	-	-	-	-	-	-	6000	6000
M_x [Nm]	-	-	-	-	-	-	-	-	-	260	285
M_y [Nm]	-	-	-	-	-	-	-	-	-	320	475
M_z [Nm]	-	-	-	-	-	-	-	-	-	320	475
Accessories											
Multi-Axis-System											
Connecting Elements	0	0	0	0	0	0	0	0	0	0	0
Connecting Shaft	0	0	0	0	0	0	0	0	0	0	0
Special Actuators											
Clean Room	X	X	X	X	X	X	X	X	X	0	0
Mountings											
Compensation	X	X	X	X	X	X	0	0	0	0	0
End Cap Mounting / Midsection Support	0	0	0	0	X	X	0	0	0	0	0
Inversion Mounting	X	X	X	X	X	X	0	0	0	0	0
Adapter Profile / T-Nut Profile	0	0	0	0	X	X	0	0	0	0	0
Magnetic Sensors											
Reeds Sensors RS (NO, NC)	0	0	0	0	0	0	0	0	0	0	0
Electronic Sensors ES (PNP, NPN)	0	0	0	0	0	0	0	0	0	0	0
Measuring Systems											
SFI-plus Displacement Measuring System	X	X	X	X	X	X	X	X	X	0	0
Motor Package (Stepper / Servo)											
	0	0	0	0	0	0	0	0	0	0	0
Gearbox											
Planetary Gears	0	0	0	0	0	0	0	0	0	0	0

□ = Standard Version
 0 = Option
 X = Currently not available

* = Other Temperature Ranges on Request
 ** = exc. Safety Clearance from Mechanical End Position
 other Stroke Lengths on Request

*** = Ratio i = 3, 5, 10

¹⁾ = Actuator with Belt and Integrated Ball Bearing Guide

²⁾ = Actuator with Belt and Integrated Roller Guide

³⁾ = Vertical Actuator with Belt and Integrated Ball Bearing Guide

⁴⁾ = Actuator with Belt and Internal Plain Bearing Guide

⁵⁾ = Actuator with Ball Screw Actuator and Internal Plain Bearing Guide

⁶⁾ = Actuator with Trapezoidal Screw Actuator and Internal Plain Bearing Guide

⁷⁾ = Actuator with Ball Screw Actuator, Internal Plain Bearing Guide and Piston Rod

⁸⁾ = Actuator with Trapezoidal Screw Actuator, Internal Plain Bearing Guide and Piston Rod



P-A4P017GB

OSP-E

Actuators	OSP-E50 -SB ⁵⁾	OSP-E25 -ST ⁶⁾	OSP-E32 -ST ⁶⁾	OSP-E50 -ST ⁶⁾	OSP-E25 -SBR ⁷⁾	OSP-E32 -SBR ⁷⁾	OSP-E50 -SBR ⁷⁾	OSP-E25 -STR ⁸⁾	OSP-E32 -STR ⁸⁾	OSP-E50 -STR ⁸⁾
Effective Action Force F_A [N]	1500	600	1300	2500	260	900	1200	800	1600	3300
Max. Velocity v [m/s]	1.25	0.1	0.1	0.15	0.25	0.5	1.25	0.075	0.1	0.125
Integrated Magnets	□	□	□	□	□	□	□	□	□	□
Free Choice of Stroke Length [mm] **	1 - 3200	1 - 1100	1 - 2000	1 - 2500	1 - 500	1 - 500	1 - 500	1 - 500	1 - 500	1 - 500
Temperature Range [°C]	-20 - +80	-20 - +70	-20 - +70	-20 - +70	-20 - +80	-20 - +80	-20 - +80	-20 - +70	-20 - +70	-20 - +70
Tandem Version	0	0	0	0	-	-	-	-	-	-
Bi-parting Version										
Stainless Steel Parts	X	X	X	X	X	X	X	X	X	X
Integrated Planetary Gearbox LPB***	-	-	-	-	-	-	-	-	-	-
Self-Guidance										
F [N]	3000	500	1000	1500	-	-	-	-	-	-
M_x [Nm]	16	2	6	13	-	-	-	-	-	-
M_y [Nm]	80	24	65	155	-	-	-	-	-	-
M_z [Nm]	32	7	12	26	-	-	-	-	-	-
Slideline										
F [N]	2000	675	925	2000	-	-	-	-	-	-
M_x [Nm]	77	14	29	77	-	-	-	-	-	-
M_y [Nm]	180	34	60	180	-	-	-	-	-	-
M_z [Nm]	180	34	60	180	-	-	-	-	-	-
Proline										
F [N]	3582	986	1348	3582	-	-	-	-	-	-
M_x [Nm]	128	19	33	128	-	-	-	-	-	-
M_y [Nm]	287	44	84	287	-	-	-	-	-	-
M_z [Nm]	287	44	84	287	-	-	-	-	-	-
Powerslide										
F [N]	3000-4000	900-1190	1400-2300	3000-4000	-	-	-	-	-	-
M_x [Nm]	90-140	14-20	20-50	90-140	-	-	-	-	-	-
M_y [Nm]	250-350	63-175	70-175	250-350	-	-	-	-	-	-
M_z [Nm]	250-350	63-175	70-175	250-350	-	-	-	-	-	-
HD-Guide (Heavy Duty)										
F [N]	18000	6000	6000	18000	-	-	-	-	-	-
M_x [Nm]	1100	260	285	1100	-	-	-	-	-	-
M_y [Nm]	1400	320	475	1400	-	-	-	-	-	-
M_z [Nm]	1400	320	475	1400	-	-	-	-	-	-
Accessories										
Multi-Axis System										
Connecting Elements	0	0	0	0	0	0	0	0	0	0
Connecting Shaft	0	0	0	0	0	0	0	0	0	0
Special Actuators										
Clean Room	0	X	X	X	X	X	X	X	X	X
Mountings										
Compensation	0	0	0	0	-	-	-	-	-	-
End Cap Mounting / Midsection Support	0	0	0	0	0	0	0	0	0	0
Inversion Mounting	0	0	0	0	-	-	-	-	-	-
Adapter Profile / T-Nut Profile	0	0	0	0	0	0	0	0	0	0
Magnetic Sensors										
Reed Sensors RS (No. NC)	0	0	0	0	0	0	0	0	0	0
Electronic Sensors ES (PNP, NPN)	0	0	0	0	0	0	0	0	0	0
Measuring systems										
SFI-plus Displacement Measuring System	0	0	0	0	-	-	-	-	-	-
Motor Package (Stepper / Servo)										
Motor Package (Stepper / Servo)	0	0	0	0	0	0	0	0	0	0
Gearbox										
Planetary Gears	0	0	0	0	0	0	0	0	0	0

□ = Standard version
 0 = Option
 X = Currently not available

* = Other Temperature Ranges on Request
 ** = exc. Safety Clearance from Mechanical End Position
 Other Stroke Lengths on Request

*** = Ratio i = 3, 5, 10

¹⁾ = Actuator with Belt and Integrated Ball Bearing Guide

²⁾ = Actuator with Belt and Integrated Roller Guide

³⁾ = Vertical Actuator with Belt and Integrated Ball Bearing Guide

⁴⁾ = Actuator with Belt and Internal Plain Bearing Guide

⁵⁾ = Actuator with Ball Screw Actuator and Internal Plain Bearing Guide

⁶⁾ = Actuator with Trapezoidal Screw Actuator and Internal Plain Bearing Guide

⁷⁾ = Actuator with Ball Screw Actuator, Internal Plain Bearing Guide and Piston Rod

⁸⁾ = Actuator with Trapezoidal Screw Actuator, Internal Plain Bearing Guide and Piston Rod



Parker Hannifin Corporation
 Pneumatic Division - Europe

P-A4P017GB

OSP-E

Drive Options

ONE Complete System
– SEVEN Actuator Options for All Possible Applications

Series OSP-E..BHD

Belt Actuator with Integrated Guide

- Ball Bearing Guide
- Roller Guide



Series OSP-E..BV

Vertical Belt Actuator with Integrated Ball Bearing Guide



Series OSP-E..B

Belt Actuator with Internal Guide



Series OSP-E..SB

Ball Screw Actuator with Internal Plain Bearing Guide

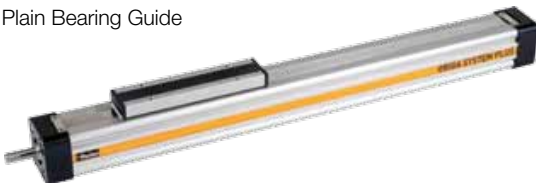

Series OSP-E..ST

Trapezoidal Screw Actuator with Internal Plain Bearing Guide



Series OSP-E..SBR

Ball Screw Actuator with Internal Plain Bearing Guide and Piston Rod



Series OSP-E..STR





Trapezoidal Screw Actuator with Internal Plain Bearing Guide and Piston Rod







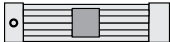

P-A4P017GB

OSP-E

Standard Versions, Options and Accessories

Description	Belt-Actuators – Basic Versions		
	Belt Actuator with Integrated Guide 	Vertical Belt Actuator with Integrated Ball Bearing Guide 	Belt Actuator with Internal Plain Bearing Guide 
Standard Versions	 – Direction of Motion – Position of the Drive Shaft	– Position of the Drive Shaft	 – Position of the Drive Shaft
Options	– Tandem – Bi-parting – Integrated Planetary Gearbox	– Tandem	– Tandem – Bi-parting – Niro
Mountings			
Compensation	–	–	○
End Cap Mounting	○	–	○
Profile Mounting	○	–	○
Inversion Mounting	–	–	○
Accessories			
Magnetic Sensors	○	○	○
Motor Mountings	○	○	○
Linear Guides	–	–	○
Multi-Axis Connection System	○	○	○

Description	Screw-Actuators - Basic Versions		
	Ball Screw Actuator with Internal Plain Bearing Guide 	Trapezoidal Screw Actuator with Internal Plain Bearing Guide 	Screw Actuator with Internal Plain Bearing Guide and Piston Rod – Ball Screw – Trapezoidal Screw 
Standard Versions	 – Spindle pitch of the Ball Screws		
Options	– Clean Room Version – Displacement Measuring System SFI-plus	– Displacement Measuring System SFI-plus	
Mountings			
Compensation	○	○	–
End Cap Mounting	○	○	○
Profile Mounting	○	○	○
Inversion Mounting	○	○	–
Accessories			
Magnetic Sensors	○	○	○
Motor Mounting	○	○	○
Flansh Mounting	–	–	○
Trunnion Mounting	–	–	○
Piston Rod Knuckle	–	–	○
Linear Guide	○	○	–
Multi-Axis Connection System	○	○	○



Parker Hannifin Corporation
Pneumatic Division - Europe

Applications for OSP-E Actuators

Auto Handling

- high speed pick and place movements

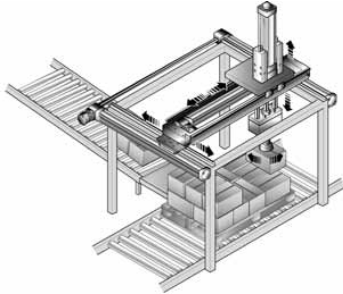

Material Handling Systems

- vertical and horizontal transfer movements

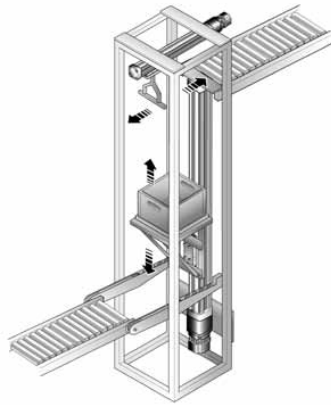

Punching Machines

- accurate feeding and positioning

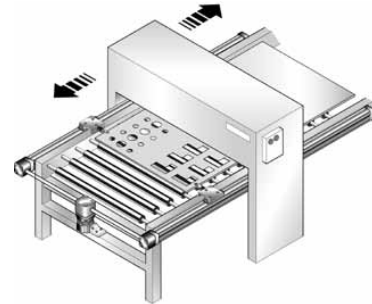

Mechanical Handling

- parallel operation of actuators on a vertical handling system

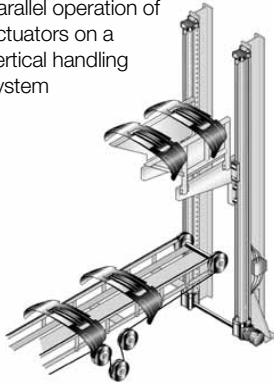

Profile Cutting Machines

- intricate profile movements of water jets and lasers

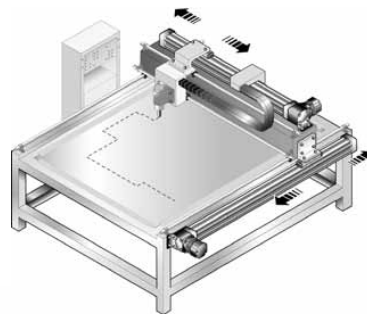

Slitting Machines

- high speed traverse applications for the slicing of papers and textiles

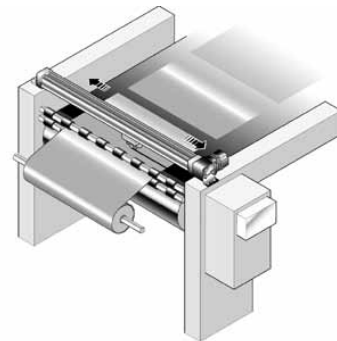

Spray Coating

- synchronized high speed bi-parting movements



Automated Filling Machines

- accurate 3-axis positioning

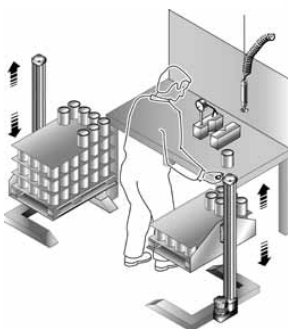
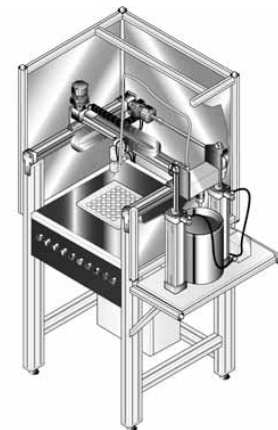

Ergonomic Workstations

- adjustment of working levels

Automatic Doors and Guards

- simple bi-parting operation



Applications for OSP-E Actuators

Robotic Installations

– traverse of robots between work stations

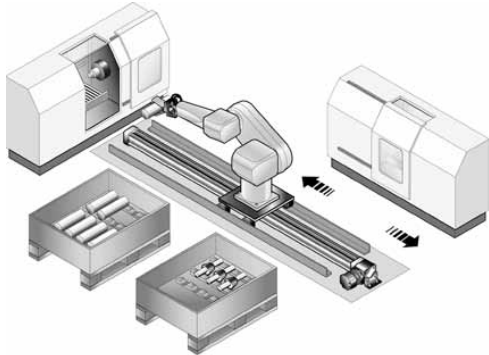

Milling Machines

– precise slow speed feeding in 2-axis

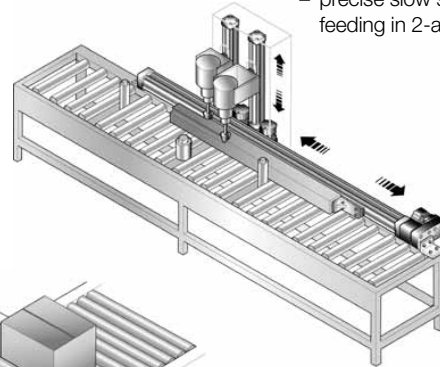

Spraying Equipment

– precision reciprocating action

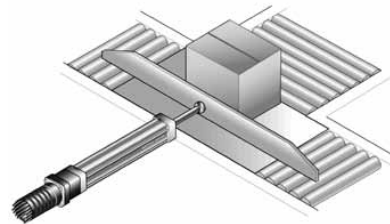
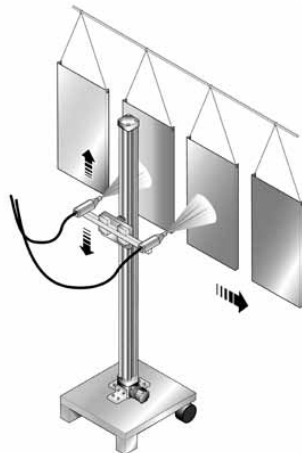

Conveyor Systems

– simple cross-transfer actuators

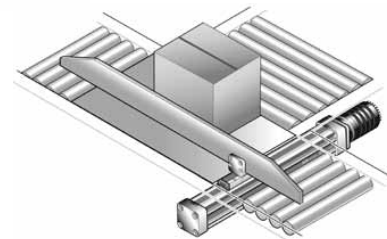

Measuring Systems

– optical curvature gauging using synchronised bi-parting actuation

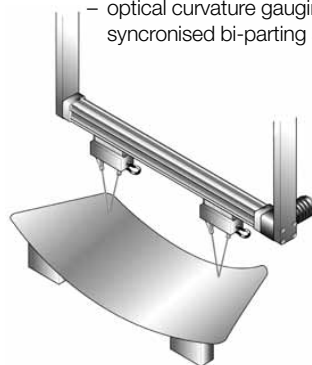

Ventilation Systems

– adjustment of air dampers

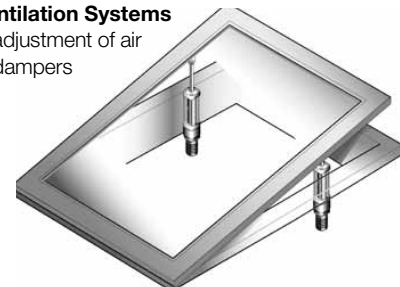

Mobile Lifting Systems

– lifting devices for industrial safety

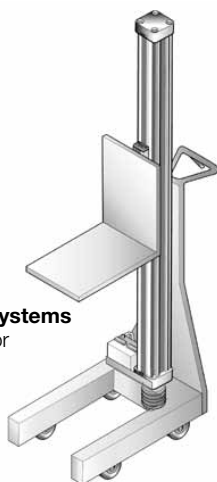

Medical Equipments

– adjustment of orthopaedic beds

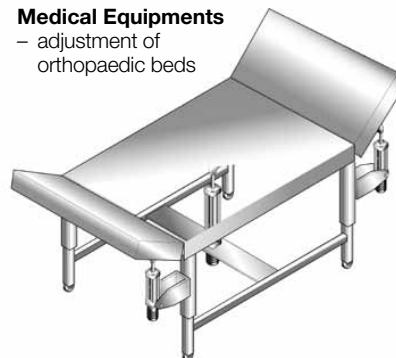

Conveyor Systems

– centring of packages on conveyor lines

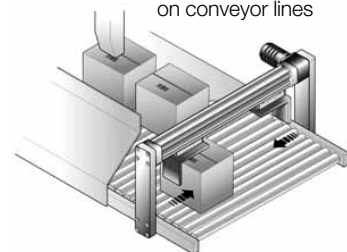

P-A4P017GB

OSP-E

P-A4P017GB
OSP-E

OSP-E..BHD Belt Actuator with Integrated Guide

Ball Bearing Guide Roller Guide



Content

Description	Page
Overview	12
Versions with Ball Bearing Guide	
Technical Data	15
Dimensions	18
Order Instructions	24
Version with Roller Guide	
Technical Data	20
Dimensions	23
Order Instructions	24

Belt Actuator with Integrated Guide for Heavy Duty Applications

The latest generation of high capacity actuators, the OSP-E..BHD series combines robustness, precision and high performance. The aesthetic design is easily integrated into any machine constructions by virtue of extremely adaptable mountings.

Belt Actuator with Integrated Guide - selective with Ball Bearing Guide or Roller Guide

Advantages:

- Accurate Path and Position Control
- High Force Output
- High Speed Operation
- High Load Capacity
- Easy Installation
- Low Maintenance
- Ideal for Multi-Axis Applications

Features:

- Integrated Ball Bearing Guide or Integrated Roller Guide
- Diverse Range of Multi-Axis Connection Elements
- Diverse Range of Accessories and Mountings
- Complete Motor and Control Packages
- Optional Integrated Planetary Gearbox
- Special Options on Request

Version with Intergrated Ball Bearing Guide

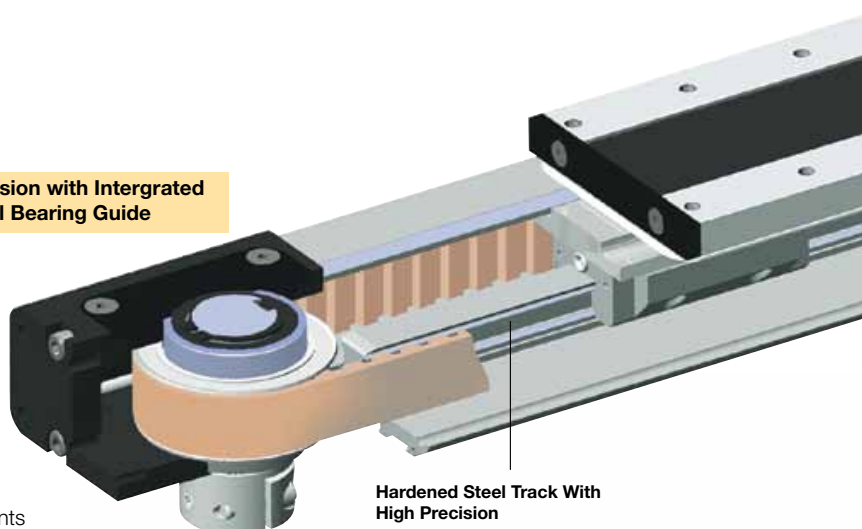

Version with Integrated Roller Guide

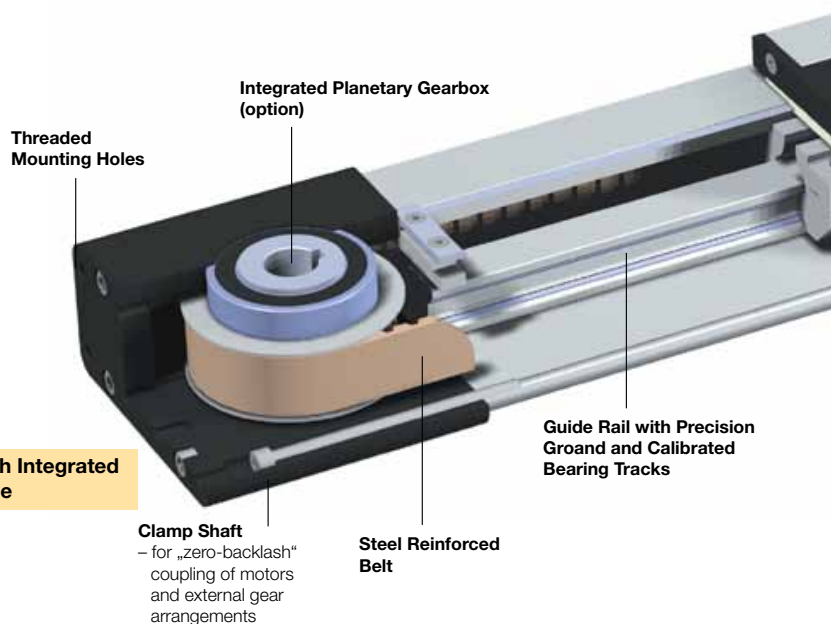

Drive Shaft Versions



Drive Shaft OPTIONS

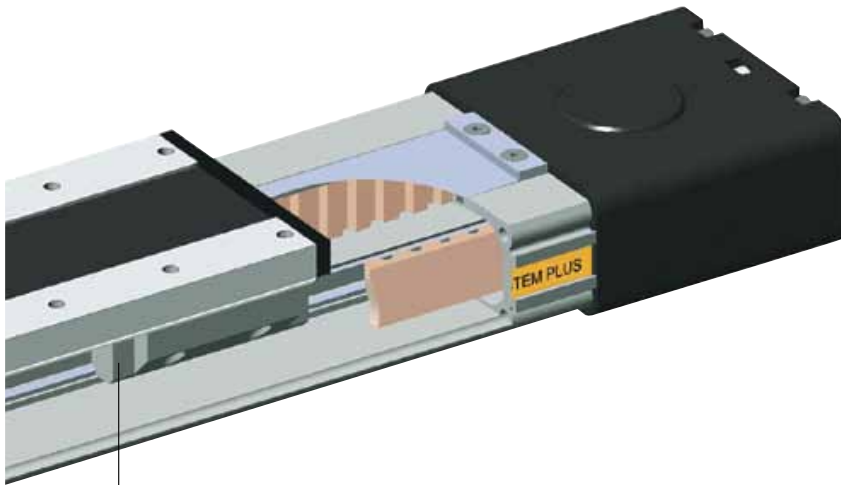

OPTION

Integrated planetary gearbox



Steel Runner Block with Integrated Scraper System and Grease Nipples

Corrosion Resistant Steel Sealing Band

Threaded Mounting Holes Compatible with Proline Series

Carriage

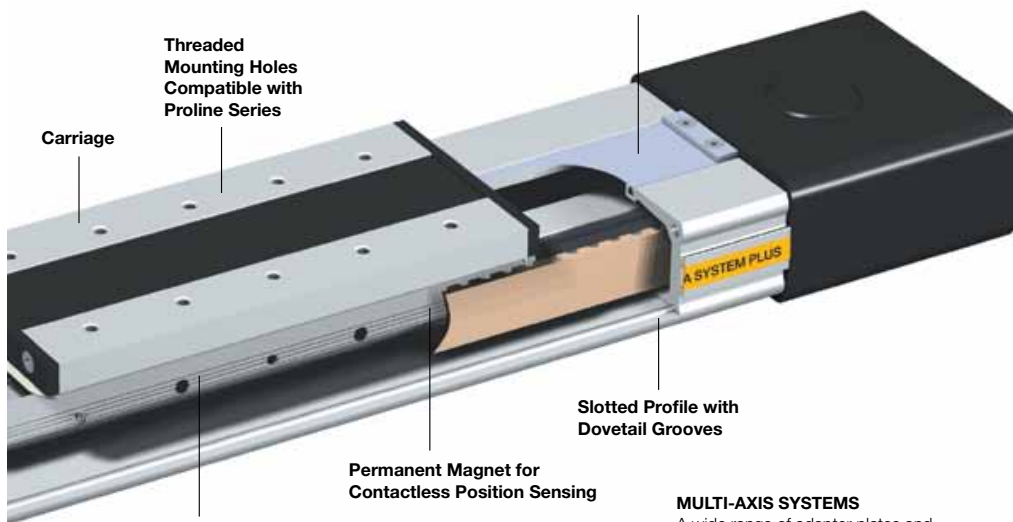

Slotted Profile with Dovetail Grooves

Permanent Magnet for Contactless Position Sensing

Rollers on Needle Bearings For Smooth Operation up to 10 m/s.

BI-PARTING Version for perfectly synchronised bi-parting movements.



MULTI-AXIS SYSTEMS

A wide range of adapter plates and intermediate drive shafts simplify engineering and installation

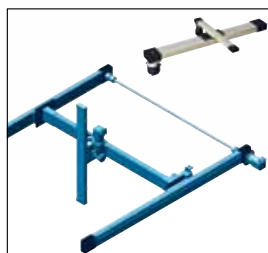

- Highly compact and rigid solution fully integrated in the drive cap housing
- Purpose designed for the BHD series
- Available with three standard ratios (3, 5 and 10)
- Very low backlash
- A wide range of available motor flanges

The dovetailed mounting rails of the new linear actuator expand its function into that of a universal system carrier. Modular system components are simply clamped on.

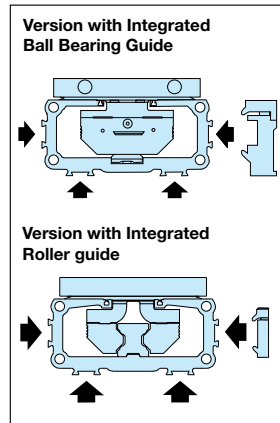

P-A4P017GB

OSP-E

Options and Accessories

OSP-E..BHD Belt Actuator with Integrated Guide

Standard Versions
OSP-E..BHD

Standard carrier with integrated guide and magnets for contactless position sensing. Dovetail profile for mounting of accessories and the actuator itself.

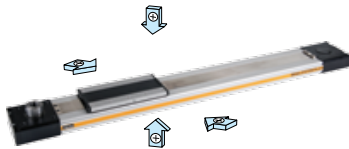

Options

Tandem
For higher moment support



Accessories

Motor Mountings



End Cap Mounting

For mounting the actuators on the end cap.

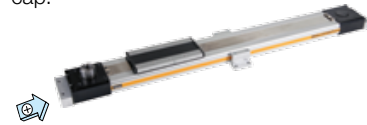

Drive Shaft with Clamp Shaft

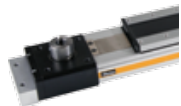

Bi-parting Version

For perfectly synchronised bi-parting movements.



Profile Mounting

For supporting long actuators or mounting the actuators on dovetail grooves



Drive Shaft with Plain Shaft



Drive Shaft with Clamp and Plain Shaft

For connections with intermediate drive shaft



Magnetic Sensors Type RS / ES

For contactless position sensing of end stop and intermediate carrier positions.

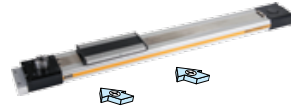

Actuating Direction

Important in parallel operations, e.g. with intermediate drive shaft

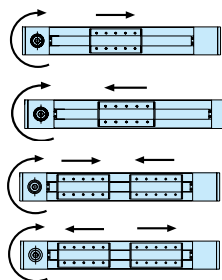

Standard

Standard -
bi-parting
Version

Hollow Shaft with Keyway

For close coupling of motors and external gears



Integrated Planetary Gearbox

For compact installation and very low backlash



Multi-Axis-Systems

For modular assembly of actuators up to multi-axis systems.

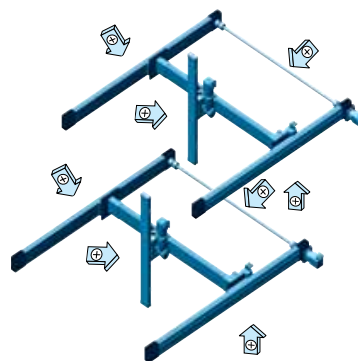

P-A4P017GB

OSP-E

OSP-E..BHD Belt Actuator with Integrated Ball Bearing Guide

Size 20 to 50

Standard Versions

- Belt Actuator with Integrated Ball Bearing Guide
- Drive Shaft with Clamp Shaft or Plain Shaft
- Choice of Motor Mounting Side
- Dovetail Profile for Mounting of Accessories and the Actuator itself

Options

- Tandem Version for Higher Moments
- Bi-parting Version for Synchronised Movements
- Integrated Planetary Gearbox
- Drive Shaft with
 - Clamp Shaft and Plain Shaft
 - Hollow Shaft with Keyway
- Special Drive Shaft Versions on Request

Characteristics

	Symbol	Unit	Description
General Features			
Series			OSP-E..BHD
Name			Belt Actuator with Integrated Ball Bearing Gear
Mounting			see drawings
Ambient Temperature Range	ϑ_{\min} ϑ_{\max}	°C °C	-30 +80
Weight (mass)		kg	see table
Installation			in any position
	Slotted profile		Extruded Anodized Aluminium
	Belt		Steel-corded Polyurethane
	Pulley		Aluminium
	Guide		Ball Bearing Guide
Material	Guide Rail		Hardened Steel Rail with High Precision, Accuracy Class N
	Guide Carrier		Steel Carrier with Integrated Wiper System, Grease Nipples, Preloaded 0.02 x C, Accuracy Class H
	Sealing Band		Hardened, Corrosion Resistant Steel
	Screws, Nuts		Zinc Plated Steel
	Mountings		Zinc Plated Steel and Aluminium
Protection Class		IP	54

Weight (mass) and Inertia

Series	Weight (mass) [kg]			Inertia [$\times 10^{-6}$ kgm ²]		
	at stroke 0 m	add per metre stroke	moving mass	at stroke 0 m	add per metre stroke	per kg mass
OSP-E20BHD	2.8	4.0	0.8	280	41	413
OSP-E25BHD	4.3	4.5	1.5	1,229	227	821
OSP-E32BHD	8.8	7.8	2.6	3,945	496	1459
OSP-E50BHD	26.0	17.0	7.8	25,678	1,738	3,103
OSP-E20BHD*	4.3	4.0	1.5	540	41	413
OSP-E25BHD*	6.7	4.5	2.8	2,353	227	821
OSP-E32BHD*	13.5	7.8	5.2	7,733	496	1,459
OSP-E50BHD*	40.0	17.0	15.0	49,180	1,738	3,103

*Version: Tandem and Bi-parting (Option)

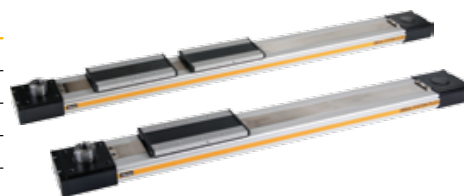

Installations Instructions

Use the threaded holes in the end cap for mounting the actuator. Check if profile mountings are needed using the maximum allowable unsupported length graph on page 17. At least one end cap must be secured to prevent axial sliding when profile mountings are used.

First service start-up

The maximum values specified in the technical data sheet for the different products must not be exceeded. Before taking the actuator as a machine into service, the user must ensure the adherence to the EC Machine Directive 2006/42/EG.

Maintenance

Depending on operating conditions, inspection of the actuator is recommended after 12 months or 3000 km operation. Please refer to the operating instructions supplied with the actuator.



Parker Hannifin Corporation
Pneumatic Division - Europe

Sizing of Actuator

The following steps are recommended:

1. Determination of the lever arm length l_x , l_y and l_z from m_e to the centre axis of the actuator.
2. Calculation of the load F_x or F_y to the carrier caused by m_e
 $F = m_e \cdot g$
3. Calculation of the static and dynamic force F_A which must be transmitted by the belt.
 $F_{A(horizontal)} = F_a + F_0$
 $= m_g \cdot a + M_0 \cdot 2\pi / U_{ZR}$
 $F_{A(vertical)} = F_g + F_a + F_0$
 $= m_g \cdot g + m_g \cdot a + M_0 \cdot 2\pi / U_{ZR}$
4. Calculation of all static and dynamic moments M_x , M_y and M_z which occur in the application.
 $M = F \cdot l$
5. Selection of maximum permissible loads via Table T3.
6. Calculation and checking of the combined load, which must not be higher than 1.
7. Checking of the maximum torque that occurs at the drive shaft in Table T2.
8. Checking of the required action force F_A with the permissible load value from Table T1.

For motor sizing, the effective torque must be determined, taking into account the cycle time.

Legend

- l = distance of a mass in the x-, y- and z-direction from the guide [m]
- m_e = external moved mass [kg]
- m_{LA} = moved mass of actuator [kg]
- m_g = total moved mass ($m_e + m_{LA}$) [kg]
- $F_{x/y}$ = load exerted on the carrier in dependence of the installation position [N]
- F_A = action force [N]
- M_0 = no-load torque [Nm]
- U_{ZR} = circumference of the pulley (linear movement per revolution) [m]
- g = gravity [m/s²]
- $a_{max.}$ = maximum acceleration [m/s²]

Performance Overview

T1

Characteristics	Unit	Description			
Series		OSP-E20BHD	OSP-E25BHD	OSP-E32BHD	OSP-E50BHD
Max. Speed	[m/s]	3 ¹⁾	5 ¹⁾	5 ¹⁾	5 ¹⁾
Linear Motion per Revolution of Drive Shaft	[mm]	125	180	240	350
Max. rpm on Drive Shaft	[min ⁻¹]	2,000	1,700	1,250	860
Max. Effective Action Force	< 1 m/s: [N]	550	1,070	1,870	3,120
F_A at Speed	1-3 m/s: [N]	450	890	1,560	2,660
	> 3 m/s: [N]	-	550	1,030	1,940
No-load Torque	[Nm]	0.6	1.2	2.2	3.2
Max. Acceleration/Deceleration	[m/s ²]	50	50	50	50
Repeatability	[mm/m]	±0.05	±0.05	±0.05	±0.05
Max. Standard Stroke Length	[mm]	5,760 ²⁾	5,700 ²⁾	5,600 ²⁾	5,500 ²⁾

¹⁾ up to 10 m/s on request
²⁾ longer strokes on request

Maximum Permissible Torque on Drive Shaft Speed / Stroke

T2

Speed [m/s]	OSP-E20BHD			OSP-E25BHD			OSP-E32BHD			OSP-E50BHD					
	Torque [Nm]	Stroke [m]	Torque [Nm]	Speed [m/s]	Torque [Nm]	Stroke [m]	Torque [Nm]	Speed [m/s]	Torque [Nm]	Stroke [m]	Torque [Nm]	Speed [m/s]	Torque [Nm]	Stroke [m]	Torque [Nm]
1	11	1	11	1	31	1	31	1	71	1	71	1	174	1	174
2	10	2	11	2	28	2	31	2	65	2	71	2	159	2	174
3	9	3	8	3	25	3	31	3	59	3	60	3	153	3	138
4		4	7	4	23	4	25	4	56	4	47	4	143	4	108
5		5	5	5	22	5	21	5	52	5	38	5	135	5	89

Important:

The maximum permissible torque on the drive shaft is the lowest value of the speed- or stroke-dependent torque value.

Example above:

OSP-E25BHD, stroke 5 m, required speed 3 m/s from table T2 speed 3 m/s gives 25 Nm and stroke 5 m gives 21 Nm. Max. torque for this application is 21 Nm.

Maximum Permissible Loads

T3

Series	Max. Applied Load		Max. Moments [Nm]		
	F_y [N]	F_z [N]	M_x	M_y	M_z
OSP-E20BHD	1,600	1,600	21	150	150
OSP-E25BHD	2,000	3,000	50	500	500
OSP-E32BHD	5000	10,000	120	1,000	1,400
OSP-E50BHD	12,000	15,000	180	1,800	2,500



Loads, Forces and Moments

Combined Loads

If the actuator is subjected to several forces, loads and moments at the same time, the maximum load is calculated with the equation shown here.

The maximum permissible loads must not be exceeded.

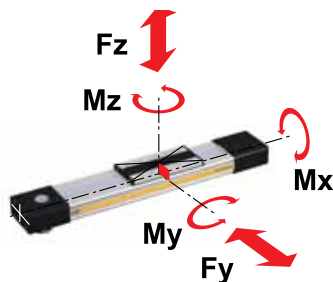

Equation of Combined Loads

$$\frac{F_y}{F_y(\max)} + \frac{F_z}{F_z(\max)} + \frac{M_x}{M_x(\max)} + \frac{M_y}{M_y(\max)} + \frac{M_z}{M_z(\max)} \leq 1$$

The total of the loads must not exceed >1 under any circumstances.

$$M = F \cdot l \text{ [Nm]}$$

$$M_x = M_{x \text{ static}} + M_{x \text{ dynamic}}$$

$$M_y = M_{y \text{ static}} + M_{y \text{ dynamic}}$$

$$M_z = M_{z \text{ static}} + M_{z \text{ dynamic}}$$

The distance (l_x, l_y, l_z) for calculation of moments relates to the centre axis of the actuator. Bending moments are calculated from the centre of the actuator and F indicates actual force.

Maximum Permissible Unsupported Length

Stroke Length

The stroke lengths of the actuators are available in multiples of 1 mm up to 5,700 mm.

Other stroke lengths are available on request. The end of stroke must not be used as a mechanical stop.

Allow an additional safety clearance at both ends equivalent to the linear movement of one revolution of the drive shaft, but at least 100 mm.

The use of an AC motor with frequency converter normally requires a larger clearance than that required for servo systems. For advice, please contact your local Parker technical support department.

* For Bi-parting version the max. load (F) is the total load of both carriers

$$F = F_{\text{carrier 1}} + F_{\text{carrier 2}}$$

k = Max. permissible distance between mountings/Profile Mounting for a given load F .

When loadings are below or up to the curve in the graph below the deflection will be max. 0.01 % of distance k .

Maximum Permissible Unsupported Length – Placing of Profile Mounting

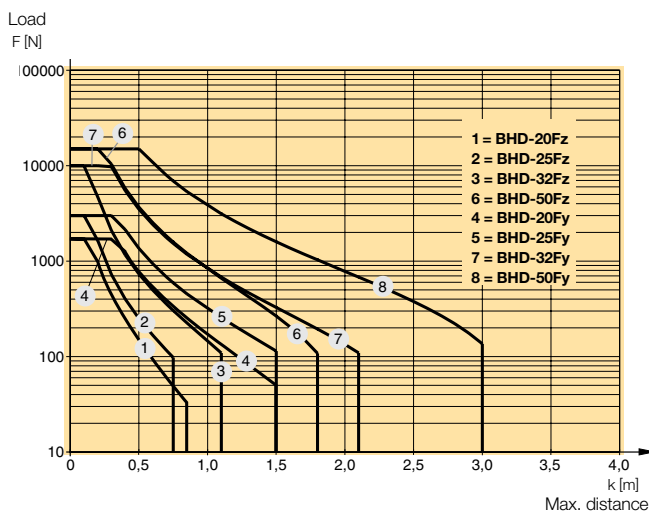
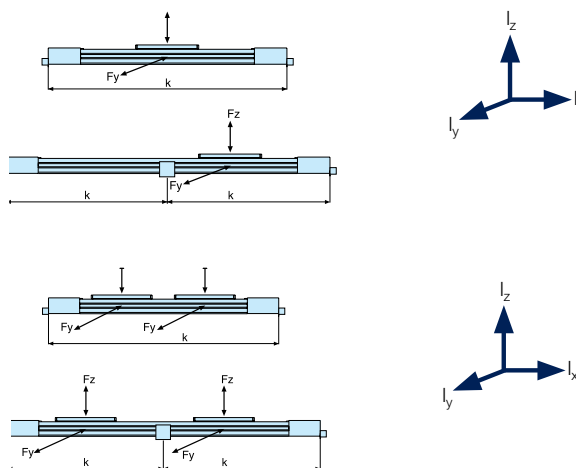

P-A4P017GB

OSP-E

OSP-E..BHD

Linear Drive with Toothed Belt and Integrated Recirculating Ball Bearing Guide - Basic Unit

Drive shaft versions with

- clamp shaft
- plain shaft
- clamp shaft with plain shaft $\frac{1}{2}$ (Option)

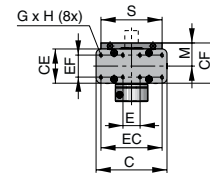
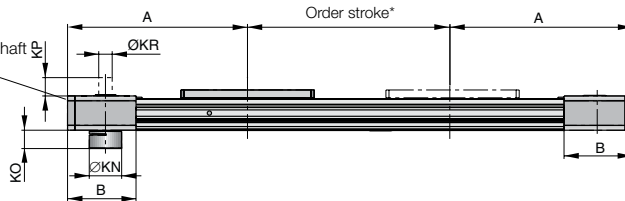

Mounting holes for motor flange or external planetary gearbox ¹⁾

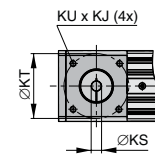
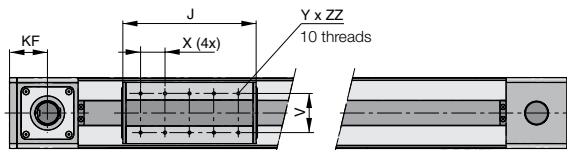

Hollow shaft with Keyway (Option)

Dimension Table [mm]

Series	KB*	KC	KL	KT	KU x KJ
OSP-E20BHD	12 ^{H7}	13.8	4	65.7	M6 x 8
OSP-E25BHD	16 ^{H7}	18.3	5	82	M8 x 8
OSP-E32BHD	22 ^{H7}	24.8	6	106	M10 x 12
OSP-E50BHD	32 ^{H7}	35.3	10	144	M12 x 19

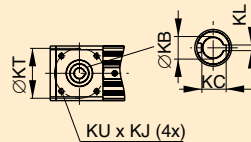

¹⁾ **Note:** The mounting holes for the coupling housing / motor flange / gearbox are located on the opposite side to the carrier (motor mounting standard). They also can be located on the same side as the carrier (motor mounting 180° standard).

* **Note:** The mechanical end position must not be used as a mechanical end stop. Allow an additional safety clearance at both ends equivalent to the linear movement of one revolution of the drive shaft, but at least 100 mm. Order stroke = required travel + 2 x safety distance. The use of an AC motor with frequency converter normally requires a larger safety clearance than that required for servo systems. For further information please contact your local Parker representative.

Option Tandem - Series OSP-E.. BHD

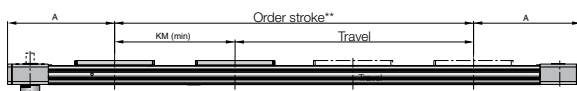

Option - Bi-Parting - Series OSP-E.. BHD

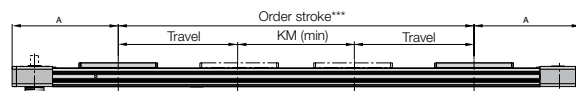

** Order stroke = required travel + KM min + 2 x safety distance

Dimension Table [mm]

Series	A	B	C	E	GxH	J	K	M	S	V	X	YxZZ	CE	CF	EC	EF	FB
OSP-E20BHD	185	76.5	73	18	M5x8.5	155	21.1	27.6	67	51	30	M5x8	38	49.0	60	27	73
OSP-E25BHD	218	88.0	93	25	M5x10	178	21.5	31.0	85	64	40	M6x8	42	52.5	79	27	92
OSP-E32BHD	262	112	116	28	M6x12	218	28.5	38.0	100	64	40	M6x10	56	66.5	100	36	116
OSP-E50BHD	347	147	175	18	M6x12	288	43.0	49.0	124	90	60	M6x10	87	92.5	158	70	164

Series	FH	KF	KM _{min}	KM _{emp.}	KN	KO	KP	KR	KS	KT	KUxKJ
OSP-E20BHD	36.0	42.5	180	220	27	18.0	25	12 _{h7}	12 ^{H7}	65.7	M6x8
OSP-E25BHD	39.5	49.0	210	250	34	21.7	30	16 _{h7}	16 ^{H7}	82.0	M8x8
OSP-E32BHD	51.7	62.0	250	300	53	30.0	30	22 _{h7}	22 ^{H7}	106.0	M10x12
OSP-E50BHD	77.0	79.5	354	400	75	41.0	35	32 _{h7}	32 ^{H7}	144.0	M12x19

(Other dimensions for KS and KB for special drive shafts on request – see order instructions.)



P-A4P017GB

OSP-E

Integrated Planetary Gearbox

Features

- Highly Compact and Rigid Solution Fully Integrated in the Drive Cap Housing
- Purpose Designed for the BHD Series.
- Available with three Standard Ratios (3, 5 and 10)
- Very Low Backlash
- Wide Range of Available Motor Flanges

Material: Aluminium (AL-H) / Steel (St-H)

Standard Version:

- Gearbox on Opposite Side to Carrier

Note: When ordering, specify model/Type of motor and manufacturer for correct motor flange.

Please contact your local Parker technical support for available motor flange.

Series OSP-E..BHD – with Integrated Planetary Gearbox (Option)



Dimensions

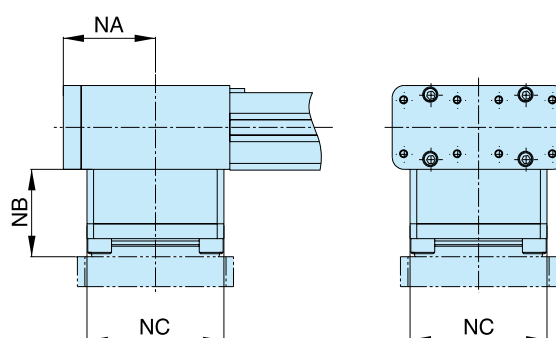

Performance Overview

Characteristics	Symbol	Unit	Description		
			OSP-E25BHD	OSP-E32BHD	OSP-E50BHD
Series					
Ratio (1-stage)	i		3/5/10		
Max. Axial Load	$F_{a\ max}$	[N]	1,550	1,900	4,000
Torsional Rigidity (i=5)	$C_{t,21}$	[Nm/arcmin]	3.3	9.5	25.0
Torsional Rigidity (i=3/10)	$C_{t,21}$	[Nm/arcmin]	2.8	7.5	22.0
Torsional Backlash	J_t	[arcmin]	<12		
Linear Motion per Revolution of Drive Shaft		[mm]	220	280	360
Nominal Input Speed	n_{nom}	[min ⁻¹]	3,700	3,400	2,600
Max. Input Speed	n_{1max}	[min ⁻¹]	6,000		
No-load Torque at Nominal Input Speed	T_{012}	[Nm]	<0.14	<0.51	<1.50
Lifetime		[h]	20,000		
Efficiency	η	[%]	>97		
Noise Level ($n_1=3000\ min^{-1}$)	L_{PA}	[db]	<70	<72	<74

Dimension Table [mm] and Additional Weight

Series	NA	NB	NC	Weight (mass) [kg]
OSP-E25BHD	49	43	76	2.6
OSP-E32BHD	62	47	92	4.9
OSP-E50BHD	80	50	121	9.6



Parker Hannifin Corporation
Pneumatic Division - Europe

P-A4P017GB

OSP-E

OSP-E...BHD Belt Actuator with integrated Roller Guide

Size 25, 32, 50

Standard Versions

- Belt Actuator with Integrated Roller Guide
- Drive Shaft with Clamp Shaft or Plain Shaft
- Choice of Motor Mounting Side
- Dovetail Profile for Mounting of Accessories and the Actuator Itself

Options

- Tandem Version for Higher Moments
- Bi-parting Version for Synchronised Movements
- Integrated Planetary Gearbox
- Drive shaft with
 - clamp shaft and plain shaft
 - hollow shaft with keyway
- Special Drive Shaft Versions on Request

Characteristics

	Symbol	Unit	Description	
General Features				
Series			OSP-E..BHD	
Name			Linear Drive with Toothed Belt and Integrated Roller Guide	
Mounting			see drawings	
Ambient Temperature Range	ϑ_{\min} ϑ_{\max}	°C °C	-30 +80	
Weight (mass)		kg	see table	
Installation			in any position	
Material	Slotted Profile		Extruded Anodized Aluminium	
	Toothed Belt		Steel-corded Polyurethane	
	Pulley		Aluminium	
	Guide		Roller Guide	
	Guide Rail		Aluminium	
	Track		High Alloyed Steel	
	Roller Cartige		Steel rollers in Aluminium Housing	
	Sealing Band		Hardened, Corrosion Resistant Steel	
	Screws, Nuts		Zinc Plated Steel	
	Mountings		Zinc Plated Steel and Aluminium	
	Protection Class		IP	54

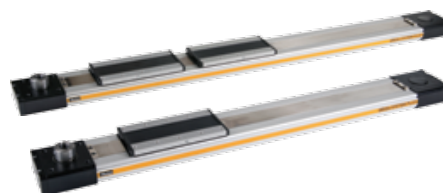

Weight (mass) and Inertia

Series	Weight (mass) [kg]			Inertia [$\times 10^{-6}$ kgm ²]		
	at stroke 0 m	ad per metre stroke	Moving mass	at stroke 0 m	ad per metre stroke	Moving mass
OSP-E25BHD	3.8	4.3	1.0	984	197	821
OSP-E32BHD	7.7	6.7	1.9	3,498	438	1,459
OSP-E50BHD	22.6	15.2	4.7	19,690	1,489	3,103
OSP-E25BHD*	5.7	4.3	2.0	1,805	197	821
OSP-E32BHD*	11.3	6.7	3.8	6,358	438	1,459
OSP-E50BHD*	31.7	15.2	9.4	34,274	1,489	3,103

* Version: Tandem and Bi-parting (Option)

Installation Instructions

Use the threaded holes in the end cap for mounting the actuator. Check if profile mountings are needed using the maximum allowable unsupported length graph on page 22. At least one end cap must be secured to prevent axial sliding when profile mountings are used.

First Service Start-up

The maximum values specified in the technical data sheet for the different products must not be exceeded. Before taking the actuator as a machine into service, the user must ensure the adherence to the EC Machine Directive 2006/42/EG.

Maintenance

Depending on operating conditions, inspection of the actuator is recommended after 12 months or 3000 km operation. Please refer to the operating instructions supplied with the actuator.



Performance Overview

Characteristics	Symbol	Description			
Series		OSP-E25BHD	OSP-E32BHD	OSP-E50BHD	
Max. Speed	[m/s]	10	10	10	
Linear Motion per Revolution Drive Shaft	[m/s]	180	240	350	
Max. rpm. Drive Shaft	[min ⁻¹]	3,000	2,500	1,700	
Max. Effective Action Force F_A at Speed	< 1 m/s:	[N]	1,070	1,870	3,120
	1-3 m/s:	[N]	890	1,560	2,660
	> 3-10 m/s:	[N]	550	1,030	1,940
No-load Torque	[Nm]	1.2	2.2	3.2	
Max. Acceleration/Deceleration	[m/s ²]	40	40	40	
Repeatability	[mm/m]	±0.05	±0.05	±0.05	
Max. Standard Stroke Length	[mm]	7,000	7,000	7,000	

T1 Sizing of Actuator

The following steps are recommended:

1. Determination of the lever arm length l_x , l_y and l_z from m_e to the centre axis of the actuator.
2. Calculation of the load F_x or F_y to the carrier caused by m_e
 $F = m_e \cdot g$
3. Calculation of the static and dynamic force F_A which must be transmitted by the belt.
 $F_{A(\text{horizontal})} = F_a + F_0$
 $= m_g \cdot a + M_0 \cdot 2\pi / U_{ZR}$
 $F_{A(\text{vertical})} = F_g + F_a + F_0$
 $= m_g \cdot g + m_g \cdot a + M_0 \cdot 2\pi / U_{ZR}$
4. Calculation of all static and dynamic bending moments M_x , M_y and M_z which occur in the application
 $M = F \cdot l$
5. Selection of maximum permissible loads via Table T3.
6. Calculation and checking of the combined load, which must not be higher than 1.
7. Checking of the maximum torque that occurs at the drive shaft in Table T2.
8. Checking of the required action force F_A with the permissible load value from Table T1.

Maximum Permissible Torque on Drive Shaft Speed and Stroke

OSP-E25BHD				OSP-E32BHD				OSP-E50BHD			
Speed [m/s]	Torque [Nm]	Stroke [m]	Torque [Nm]	Speed [m/s]	Torque [Nm]	Stroke [m]	Torque [Nm]	Speed [m/s]	Torque [Nm]	Stroke [m]	Torque [Nm]
1	31	1	31	1	71	1	71	1	174	1	174
2	28	2	31	2	65	2	71	2	159	2	174
3	25	3	31	3	59	3	60	3	153	3	138
4	23	4	25	4	56	4	47	4	143	4	108
5	22	5	21	5	52	5	38	5	135	5	89
6	21	6	17	6	50	6	32	6	132	6	76
7	19	7	15	7	47	7	28	7	126	7	66
8	18			8	46			8	120		
9	17			9	44			9	116		
10	16			10	39			10	108		

T2

Important:

The maximum permissible torque on the drive shaft is the lowest value of the speed- or stroke-dependent torque value.

Example above:

OSP-E25BHD, stroke 5 m, required speed 3 m/s from table T2 speed 3 m/s gives 25 Nm and stroke 5 m gives 21 Nm. Max. torque for this application is 21 Nm.

Maximum Permissible Loads

Series	Max. applied load F_y, F_z [N]	Max. moments [Nm]		
		M_x	M_y	M_z
OSP-E25BHD	986	11	64	64
OSP-E32BHD	1,348	19	115	115
OSP-E50BHD	3,704	87	365	365

T3

For motor sizing, the effective torque must be determined, taking into account the cycle time.

Legend

- l = distance of a mass in the x-, y- and z-direction from the guide [m]
- m_e = external moved mass [kg]
- m_{LA} = moved mass of actuator [kg]
- m_g = total moved mass ($m_e + m_{LA}$) [kg]
- $F_{x/y}$ = load exerted on the carrier in dependence of the installation position [N]
- F_A = action force [N]
- M_0 = no-load torque [Nm]
- U_{ZR} = circumference of the pulley (linear movement per revolution) [m]
- g = gravity [m/s²]
- $a_{max.}$ = maximum acceleration [m/s²]

Loads, Forces and Moments

Combined Loads

If the actuator is subjected to several forces, loads and moments at the same time, the maximum load is calculated with the equation shown here.

The maximum permissible loads must not be exceeded.

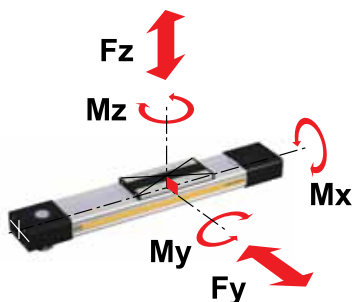

Equation of Combined Loads

$$\frac{F_x}{F_x(\max)} + \frac{F_y}{F_y(\max)} + \frac{F_z}{F_z(\max)} + \frac{M_x}{M_x(\max)} + \frac{M_y}{M_y(\max)} + \frac{M_z}{M_z(\max)} \leq 1$$

The total of the loads must not exceed >1 under any circumstances.

$$M = F \cdot l \text{ [Nm]}$$

$$M_x = M_{x \text{ static}} + M_{x \text{ dynamic}}$$

$$M_y = M_{y \text{ static}} + M_{y \text{ dynamic}}$$

$$M_z = M_{z \text{ static}} + M_{z \text{ dynamic}}$$

The distance (l_x, l_y, l_z) for calculation of moments relates to the centre axis of the actuator. Bending moments are calculated from the centre of the actuator and F indicates actual force.

Maximum Permissible Unsupported Length

Stroke length

The stroke lengths of the actuators are available in multiples of 1 mm up to 5700 mm.

Other stroke lengths are available on request.

The end of stroke must not be used as a mechanical stop.

Allow an additional safety clearance at both ends equivalent to the linear movement of one revolution of the drive shaft, but at least 100 mm.

The use of an AC motor with frequency converter normally requires a larger clearance than that required for servo systems.

For advice, please contact your local Parker technical support department.

* For the bi-parting version the maximum load (F) complies with the total of the load at both carriers.

$$F = F_{\text{carriage 1}} + F_{\text{carriage 2}}$$

k = Maximum permissible distance between mountings/mid-section support for a given load F.

If the loads are below or up to the curve in the graph the deflection will be max. 0.01 % of distance k.

Maximum Permissible Unsupported Length – Placing of Profile Mounting

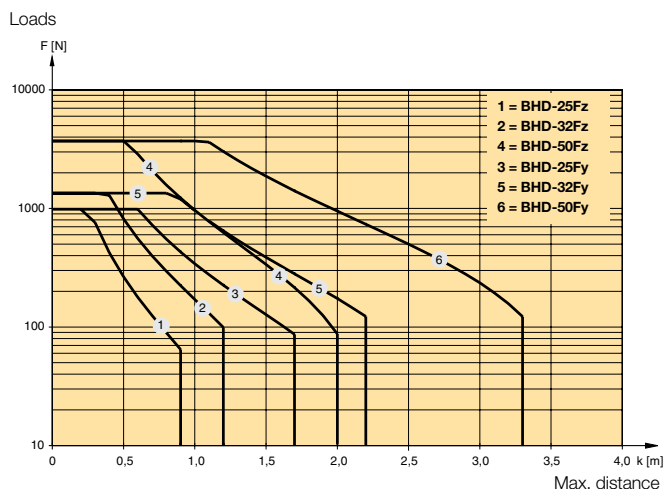
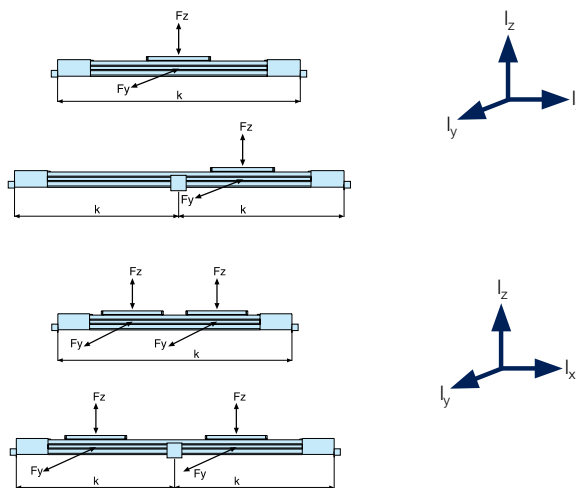

P-A4P017GB

OSP-E

Loads, Forces and Moments

Linear Drive with Toothed Belt and Integrated Roller Guide - Basic Unit OSP-E..BHD

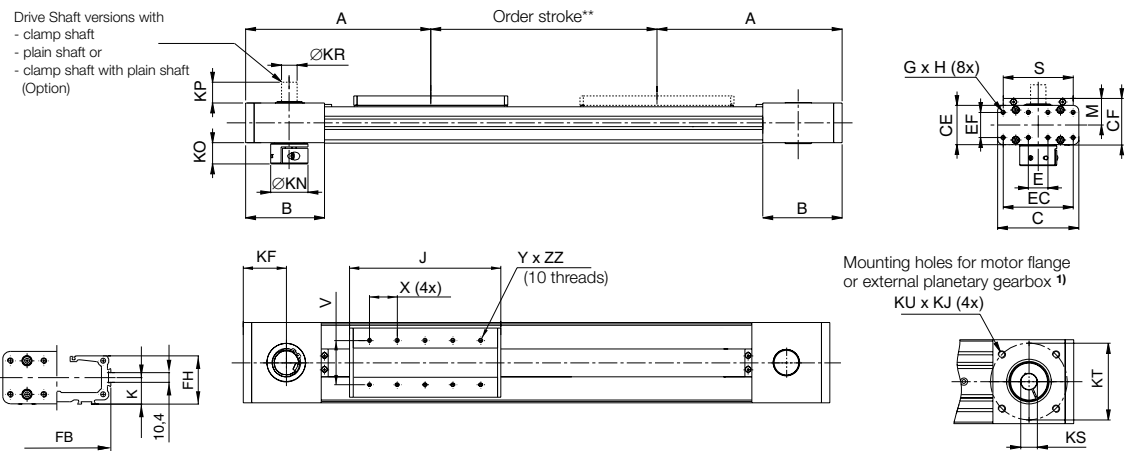

Hollow Shaft with Keyway (Option)

Dimension [mm]

Series	KB*	KC	KL	KT	KU x KJ
OSP-E25BHD	16 ^{H7}	18.3	5	82	M8 x 8
OSP-E25BHD	22 ^{H7}	24.8	6	106	M10 x 12
OSP-E50BHD	32 ^{H7}	35.3	10	144	M12 x 19

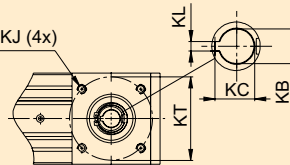

¹⁾ **Note:** The mounting holes for the coupling housing / motor flange / gearbox are located on the opposite side to the carrier (motor mounting standard). They also can be located on the same side as the carrier (motor mounting 180° standard).

* **Note:** The mechanical end position must not be used as a mechanical end stop. Allow an additional safety clearance at both ends equivalent to the linear movement of one revolution of the drive shaft, but at least 100 mm. Order stroke = required travel + 2 x safety distance. The use of an AC motor with frequency converter normally requires a larger safety clearance than that required for servo systems. For further information please contact your local Parker representative.

Option Tandem

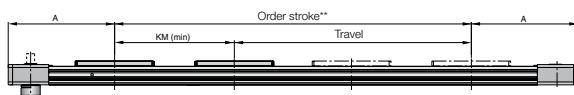

** Order stroke = required travel + KM min + 2 x safety distance

Option - Bi-Parting

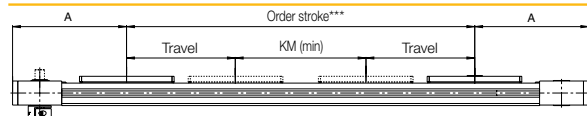

*** Order stroke = 2 x required travel + KM min + 2 x safety distance

Dimension Table [mm]

Series	A	B	C	E	GxH	J	K	M	S	V	X	YxZZ	CE	CF
OSP-E25BHD	218	88.0	93	25	M5x10	178	21.5	31.0	85	64	40	M6x8	42	52.5
OSP-E32BHD	262	112	116	28	M6x12	218	28.5	38.0	100	64	40	M6x10	56	66.5
OSP-E50BHD	347	147	175	18	M6x12	263	43.0	49.0	124	90	60	M6x10	87	92.5

Series	EC	EF	FB	FH	KF	KM _{min}	KM _{emp.}	KN	KO	KP	KR	KS	KT	KUxKJ
OSP-E25BHD	79	27	92	39.5	49.0	210	250	34	21.7	30	16 _{H7}	16 ^{H7}	82.0	M8x8
OSP-E32BHD	100	36	116	51.7	62.0	250	300	53	30.0	30	22 _{H7}	22 ^{H7}	106.0	M10x12
OSP-E50BHD	158	70	164	77.0	79.5	295	350	75	41.0	35	32 _{H7}	32 ^{H7}	144.0	M12x19

Other dimensions for KS and KB for special drive shafts on request - see other instructions.



Parker Hannifin Corporation
Pneumatic Division - Europe

P-A4P017GB

OSP-E

Order Instructions	OSPE20	-	6	0	0	02	-	0000	-	0	00	0	0	0
--------------------	--------	---	---	---	---	----	---	------	---	---	----	---	---	---

Size of Actuator	
20	Size 20 (only Type of actuator 6)
25	Size 25
32	Size 32
50	Size 50

Type of Actuator	
5	Belt Actuator with Integrated Roller Guide (for size 25, 32 and 50)
6	Belt Actuator with Integrated Ball Bearing Guide

Carriage	
0	Standard
1*	Tandem
2*	Bi-parting

Operating Direction	
0	Standard right
1	Standard left
2	Bi-parting right
3	Bi-parting left

Order stroke	
5 digits input in mm	

Drive Shaft		Special drive shaft on request (8/9)
Motor mounting position see M		
0 A	Plain Shaft	
0 B	Plain Shaft	
0 2	Clamp Shaft	
0 3*	Clamp Shaft with Plain Shaft	
0 4	Clamp Shaft	
0 5*	Clamp Shaft with Plain Shaft	
0 6*	Hollow Shaft with Keyway	
0 7*	Hollow Shaft with Keyway	

Integrated Gear *		
1 x**	Ratio i=3	
2 x**	Ratio i=5	
3 x**	Ratio i=10	
4 x**	Ratio i=3	
5 x**	Ratio i=5	
6 x**	Ratio i=10	

OSP-E.. BHD as Parallel Actuator with Intermediate Drive Shaft MAS-..

OSP-E..60005-..	M	
OSP-E..6010A-..		
OSP-E..60003-..	M	
OSP-E..6010B-..		

Drive shaft
 Operating direction

P-A4P017GB

OSP-E

Mounting Kit for Gear *					
Size		20	25	32	50
A7	PS60	x ²	x ¹		
A8	PS90			x ¹	
A9	PS115				x ¹
C0	LP050 / PV40-TA	x ¹			
C1	LP070 / PV60-TA	x ²	x ¹		
C2	LP090 / PV90-TA			x ¹	
C3	LP120				x ¹

x¹: Kit for **Drive Shaft** with clamp shaft
(02 / 03 / 04 / 05)

x²: Kit for **Drive Shaft** with plain shaft
(0A / 0B)

Info: Motor and gear mounting dimensions see page 191

Niro	
0	Standard
1*	Niro Screws

* Option

** for sizes 25, 32 and 5

Magnetic Sensors * see page 165 ff

0	without
1	1 pc. RST-K 2NO / 5 m cable
2	1 pc. RST-K 2NC / 5 m cable
3	2 pc. RST-K 2NC / 5 m cable
4	2 pc. RST-K 2NC, 1 pc. RST-K 2NO / 5 m cable
5	1 pc. RST-S 2NO / M8 plug
6	1 pc. RST-S 2NC / M8 plug
7	2 pc. RST-S 2NC / M8 plug
8	2 pc. RST-S 2NC, 1 pc. RST-S 2NO / M8 plug
A	1 pc. EST-S NPN / M8 plug
B	2 pc. EST-S NPN / M8 plug
C	3 pc. EST-S NPN / M8 plug
D	1 pc. EST-S PNP / M8 plug
E	2 pc. EST-S PNP / M8 plug
F	3 pc. EST-S PNP / M8 plug

Profile Mounting * see page 147 ff

0	without
1	1 Pair Type E1
2	1 Pair Type D1
3	1 Pair Type MAE
4	2 Pair Type 1
5	2 Pair Type D1
6	2 Pair Type MAE
7	3 Pair Type 1
8	3 Pair Type D1
9	3 Pair Type MAE
A	4 Pair Type 1
B	4 Pair Type D1
C	4 Pair Type MAE

End Cap Mounting * see page 141 ff

0	without
A	1 pair Type CN
B	1 pair Type CO

Accessories - please order separately

Description	Page
Motor Mountings	135
Multi-Axis Systems for Actuators	177 ff

P-A4P017GB

OSP-E

P-A4P017GB

OSP-E

OSP-E.. BV Vertical Belt Actuator with Integrated Ball Bearing Guide



Content

Description	Page
Overview	28
Technical Data	31
Dimensions	34
Order Instructions	36

P-A4P017GB

OSP-E

Vertical Belt Actuator with Integrated Ball Bearing Guide in Multi-Axis Systems

The OSP-E..BV vertical belt actuator with integrated ball bearing guide has been specially developed for lifting movements in the Z-axis.

The especially low vibration OSP-E..BV vertical actuator in combination with the heavy duty series OSP-E..BHD meets the highest demands in portal and handling applications.

Advantages

- Fixed Actuator Head for Low Moving Mass
- Integrated ball bearing guide for high bending moments
- Magnetic Sensor set for contactless position sensing
- Easy to install
- Low Maintenance

Features

- High Acceleration and Speed
- Drive Shaft Versions with Clamp Shaft or Plain Shaft
- Power Transmission by Belt
- Moving Axis Profile
- Complete Motor and Control Packages

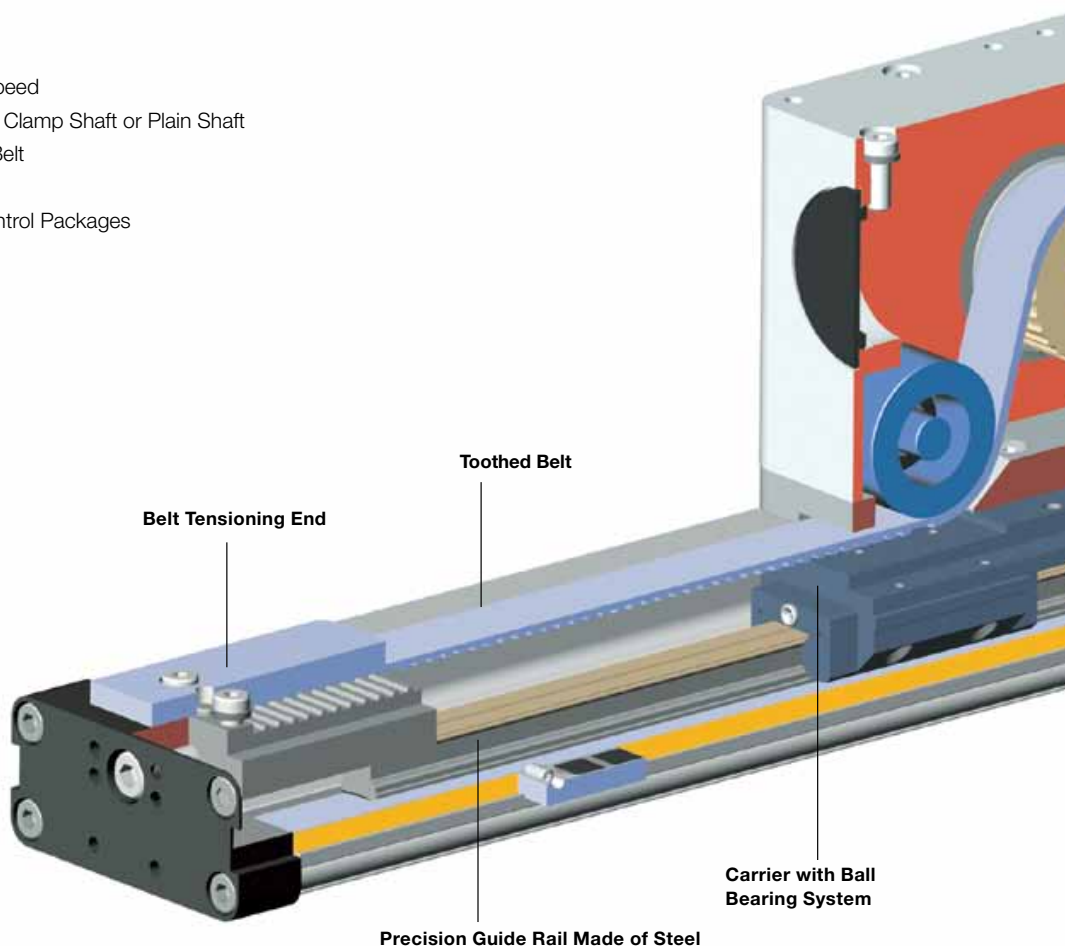

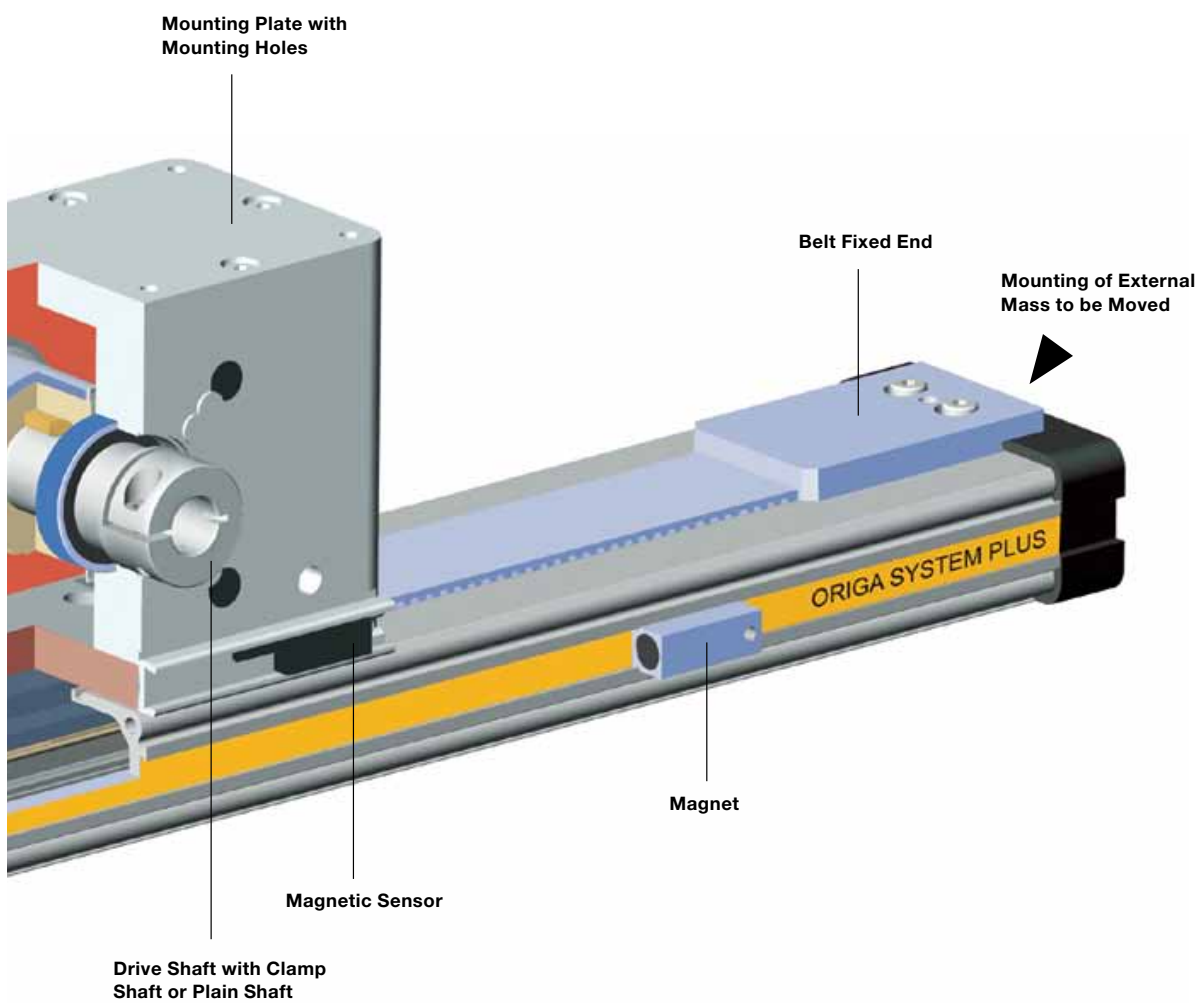

OSP-E..BV, Vertical Belt Actuator with Integrated Ball Bearing Guide

**Standard Version
OSP-E..BV**

Standard actuator head with clamp shaft or plain shaft and integrated ball bearing guide with two carriers. Choice of side on which gearbox or motor is to be mounted.

Drive Shaft with Clamp Shaft

Drive Shaft with Plain Shaft

Drive Shaft "Clamp Shaft and Plain Shaft" or "Double Plain Shaft"
e.g. for parallel operation of two Z-axes with an intermediate drive shaft.

Drive Shaft with Clamp Shaft and Plain Shaft

Drive Shaft with Double Plain Shaft



Options

Tandem

Additional actuator head and two additional carriers for higher bending moments.



Hollow shaft with keyway

For direct connection of gearbox or motor with keyway.

Accessories

Motor Mountings

For connection of gearbox or motor direct to drive shaft with clamp shaft, or with a motor coupling to drive shaft with plain shaft.



Magnetic Sensors Set

Magnetic Sensors with connector, mounting rail and magnets for contactless sensing of the end positions. Cable (suitable for cable chain) can be ordered separately in 5 m, 10 m or 15 m length.

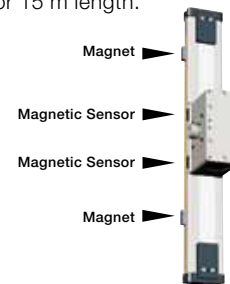

Multi-Axis-Systems

For modular assembly of actuators up to multi-axis systems.

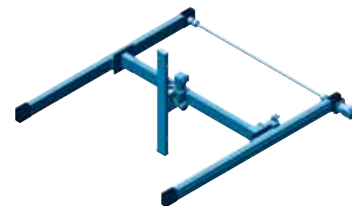

OSP-E..BV Vertical Belt Acuator with Integrated Ball Bearing Guide - Size 20, 25

Standard Version

- Vertical Belt Acuator with Integrated Ball Bearing Guide
- Drive Shaft with Clamp Shaft or Plain Shaft
- Choice of Motor Mounting Side

Options

- Tandem Version for Higher Moments
- Drive Shaft with
 - Clamp Shaft and Plain Shaft or Double Plain shaft
 - Hollow Shaft with Keyway
- Special Drive Shaft Versions on Request

Characteristics

	Symbol	Unit	Description
General Features			
Series			OSP-E..BV
Name			Vertical Belt Actuator with Integrated Ball Bearing Guide
Mounting			see drawings
Temperature Range	ϑ_{min} ϑ_{max}	°C	-30 +80
Weight (mass)		kg	see table
Installation			Vertical
Material	Profile		Extruded Anodized Aluminium
	Belt		Steel-Corded Polyurethane
	Pulley		Aluminium
	Guide		Ball Bearing Guide
	Guide Rail		Hardened Steel Rail with High Precision, Accuracy Class N
	Guide Carrier		Steel Carrier with Integrated Wiper System, Grease Nipples, Preloaded 0.08 x C, Accuracy Class N
	Sealing Band		Hardened, Corrosion Resistant Steel
	Screws, Nuts		Zinc Plated Steel
Encapsulating Class		IP	20

Weight (mass) and Inertia

Series	Total weight (Mass) [kg]		Moving mass [kg]		Inertia [$\times 10^{-6}$ kgm ²]		
	At stroke 0 m	Actuator head	At stroke 0 m	Add per metre stroke	At Stroke 0 m	Add per metre stroke	Add per kg mass
OSP-E20BV	3.4	1.9	1.6	4.0	486	1,144	289
OSP-E25BV	7.7	5.3	2.4	4.4	1,695	2,668	617
OSP-E20BV*	5.3	2 x 1.9	1.6	4.0	533	1,144	289
OSP-E25BV*	13	2 x 5.3	2.4	4.4	1,915	2,668	617

* Version: Tandem (Option)



Installation Instructions

Make sure that the OSP-E..BV is always operated by motor with holding brake on the actuator side. For the mounting of the external mass to be moved there are threaded holes in the end caps. Before mounting, check the correct centre of gravity distance from the table.

Mount the external mass on the belt fixed end, so that the belt tension can be checked and adjusted at the belt tensioning end without dismantling.

Maintenance

Depending on operating conditions, inspection of the actuator is recommended after 12 months or 3000 km operation. Please refer to the operating instructions supplied with the actuator.

First service start-up

The maximum values specified in the technical data sheet for the different products must not be exceeded. Before taking the actuator as a machine into service, the user must ensure the adherence to the EC Machine Directive 2006/42/EG.



P-A4P017GB

OSP-E

Sizing Performance Overview / Maximum Loads

Sizing of Actuator

The following steps are recommended:

1. Determination of the lever arm length l_x , l_y and l_z from m_e to the centre axis of the actuator.
2. Calculation of the static and dynamic force F_A which must be transmitted by the belt.

$$F_A = F_g + F_a + F_0$$

$$= m_g \cdot g + m_g \cdot a + M_0 \cdot 2\pi / U_{ZR}$$
3. Calculation of all static and dynamic moments M_x , M_y and M_z which occur in the application.

$$M = F \cdot l$$
4. Selection of maximum permissible loads via Table T3.
5. Calculation and checking of the combined load, which must not be higher than 1.
6. Checking of the maximum moment that occurs at the drive shaft in Table T2.
7. Checking of the required action force F_A with the permissible load value from Table T1.

For motor sizing, the effective torque must be determined, taking into account the cycle time.

Legend

- l = distance of a mass in the x-, y- and z-direction from the guide [m]
- m_e = external moved mass [kg]
- m_{LA} = moved mass of actuator [kg]
- m_g = total moved mass ($m_e + m_{LA}$) [kg]
- F_A = action force [N]
- M_0 = no-load torque [Nm]
- U_{ZR} = circumference of the pulley (linear movement per revolution) [m]
- g = gravity [m/s²]
- a_{max} = maximum acceleration [m/s²]

Performance Overview

T1

Characteristics	Unit	Description	
Series		OSP-E20BV	OSP-E25BV
Max. Speed	[m/s]	3.0	5.0
Linear Motion per Revolution of Drive Shaft	[mm/U]	108	160
Max. rpm. Drive Shaft	[min ⁻¹]	1700	1875
Max. Effective Action Force F_A at Speed	1 m/s	[N]	650
	1 - 2 m/s	[N]	450
	> 3 - 5 m/s	[N]	–
No-Load Torque ²⁾	[Nm]	0.6	1.2
Max. Acceleration/Deceleration	[m/s ²]	20	20
Repeatability	+/- [mm/m]	0.05	0.05
Max. Standard Stroke Length ¹⁾	[mm]	1,000	1,500
Max. Recommended Permissible Mass ³⁾	[kg]	10	20

¹⁾ Longer strokes on request

²⁾ As a result of static friction force

³⁾ vertical

Max. Permissible Torque on Drive Shaft Speed / Stroke

T2

OSP-E-20BV				OSP-E-25BV			
Speed [m/s]	Torque [Nm]	Stroke [m]	Torque [Nm]	Speed [m/s]	Torque [Nm]	Stroke [m]	Torque [Nm]
1	19	1	17	1	36	1	36
2	17	2	11	2	30	2	36
3	16			3	30		
				4	28		
				5	27		

Important:

The maximum permissible torque on the drive shaft is the lowest value of the speed- or stroke-dependent torque value.

Example above:

OSP-E25BV required speed $v = 3$ m/s and stroke = 1 m.

Accordingly Table T2 shows permissible moments of 30 Nm for the speed and 36 Nm for the stroke. Therefore the maximum moment at the drive shaft is determined by the speed and must not exceed 30 Nm.

Maximum Permissible Loads

T3

Forces, Loads and Moments

Series	Max. applied load		Max. moments		
	F _y [N]	F _z [N]	M _x [Nm]	M _y [Nm]	M _z [Nm]
OSP-E20BV	1600	1600	20	100	100
OSP-E25BV	2000	3000	50	200	200

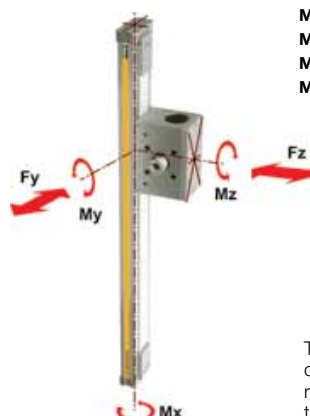

$M = F \cdot l$ [Nm]
 $M_x = M_{x \text{ statically}} + M_{x \text{ dynamically}}$
 $M_y = M_{y \text{ statically}} + M_{y \text{ dynamically}}$
 $M_z = M_{z \text{ statically}} + M_{z \text{ dynamically}}$

The distance (l_x, l_y, l_z) for calculation of moments relates to the centre axis of the actuator.

Combined Loads

If the actuator is subjected to several forces, loads and moments at the same time, the maximum load is calculated with the equation shown here. The maximum permissible loads must not be exceeded.

Equation of Combined Loads

$$\frac{F_y}{F_y(\text{max})} + \frac{F_z}{F_z(\text{max})} + \frac{M_x}{M_x(\text{max})} + \frac{M_y}{M_y(\text{max})} + \frac{M_z}{M_z(\text{max})} \leq 1$$

The total of the loads must not exceed >1 under any circumstances.

Distance of Centre of Gravity of External Mass from Mid-Point of Actuator

Mass [kg]	OSP-E20BV		OSP-E25BV	
	Lever arm l_z [mm]	Max. permissible acceleration/ deceleration [m/s ²]	Lever arm l_z [mm]	Max. permissible acceleration/ deceleration [m/s ²]
> 3 to 5	0	20	50	20
> 5 to 10	0	20	40	20
> 10 to 15	-	-	35	20
> 15 to 20	-	-	30	15

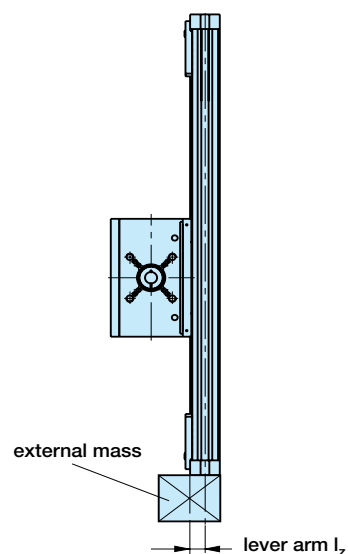

P-A4P017GB

OSP-E

OSP-E..BV Vertical Belt Actuator with Integrated Ball Bearing Guide – Basic Unit

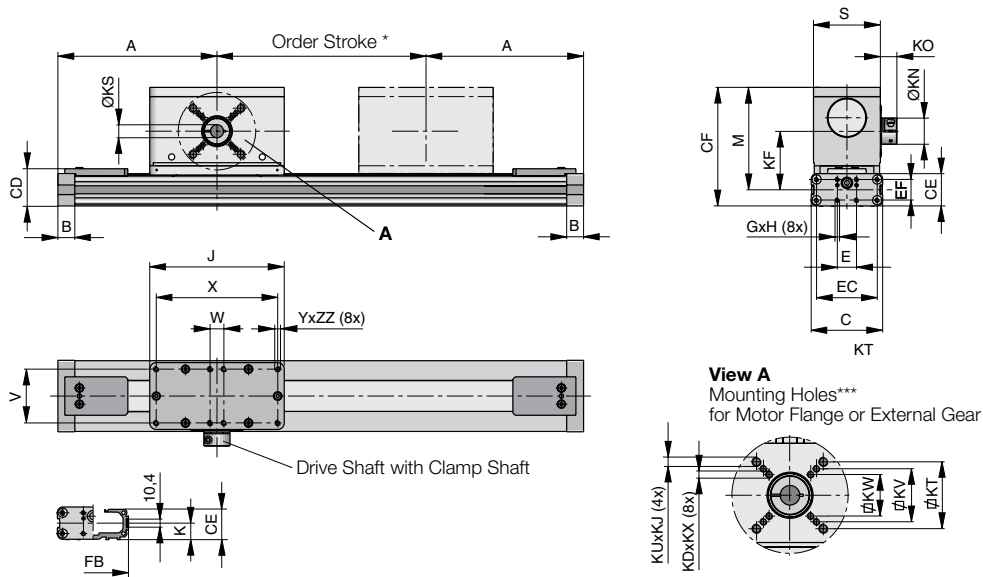

Plain Shaft

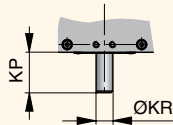

Hollow Shaft with Keyway (Option)

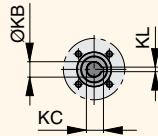

Series	ØKB	KC	KL	KP	ØKR
OSP-E20BV	12 ^{H7}	13.8	4	28.5	12 _{h7}
OSP-E25BV	16 ^{H7}	18.3	5	31.5	16 _{h7}

* **Note:** The mechanical end position must not be used as a mechanical end stop. Allow an additional safety clearance at both ends equivalent to the linear movement of one revolution of the drive shaft, but at least 100 mm. Order stroke = required travel + 2 x safety distance. The use of an AC motor with frequency converter normally requires a larger safety clearance than that required for servo systems. For further information please contact your local Parker representative.

Option – Tandem

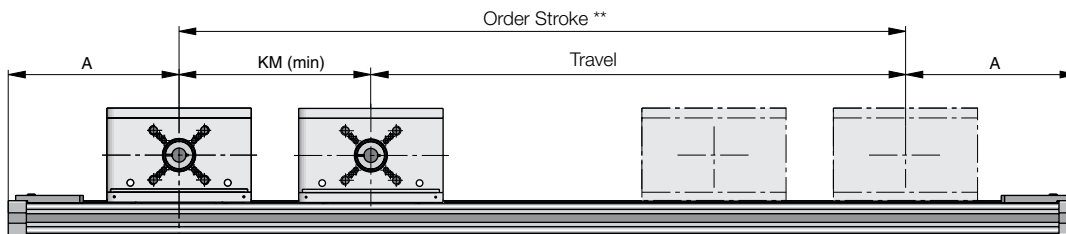

** Order stroke = required travel + KM min + 2 x safety distance.

*** The mounting holes for the coupling housing are on the motor-mounting side. Therefore please ensure that the motor mounting side is correctly stated when ordering the actuator. (For special drive shafts, other dimensions for KS and KB are available on request – see order instructions.)



P-A4P017GB

OSP-E

Dimension Table [mm]

Series	A	B	C	E	GxH	J	K	M	S	V	W	X	Y	GD	GE	CF
OSP-E20BV	148	22	93	25	M5x12	139	21.1	102.3	68	51	40	120	M6	40.4	34	123.3
OSP-E25BV	210	22	93	25	M5x12	175	21.5	133.5	87	70	18	158	M6	49.0	42	154.5

Series	EC	EF	FB	FH	KDxKX	KF	KM _{min}	KN	KO	KS	KT	KUxKJ	KV	KW	ZZ
OSP-E20BV	59	21	73	36.0	–	61.3	155	27	16	12 ^{H7}	46.5	M6x10	36	–	10
OSP-E25BV	79	27	92	39.5	M6x16	76.0	225	34	21.5	16 ^{H7}	58.0	M8x16	46	36	10

Contactless Position Sensing with Magnetic Sensors

The magnetic sensor set, comprising two magnetic sensors, a mounting rail and two magnets, is for contactless sensing of the end positions. The mounting rail and magnetic sensors are mounted on the actuator head and the magnets are mounted in the dovetail slot on the profile. The magnetic sensors are the RST-S Type (connector version). For the connecting cable Parker recommends the use of cable suitable for cable chain.

Dimensions

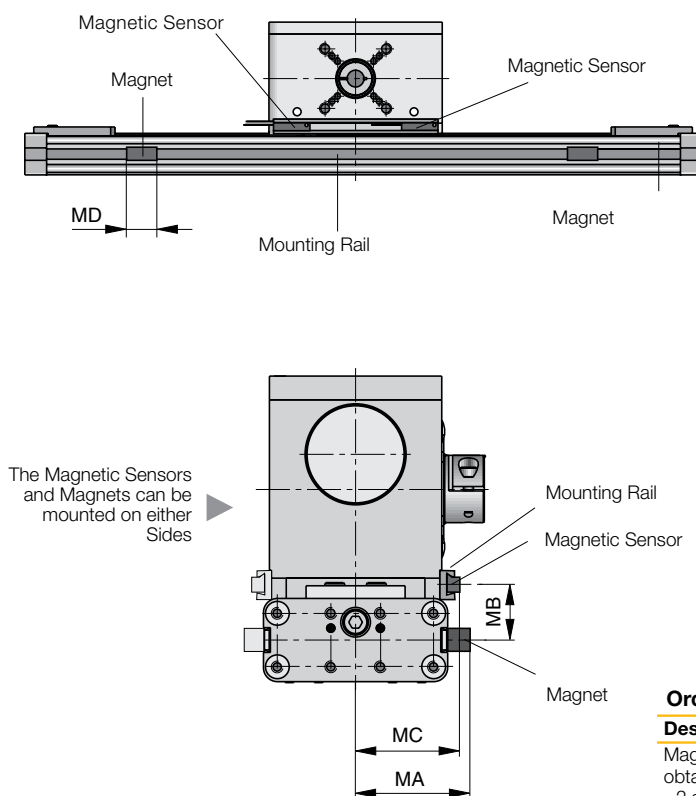

Dimension table [mm]

Series	MA	MB	MC	MD
OSP-E20BV	46	23.7	42.3	35
OSP-E25BV	56	26.0	51.0	35

Order Instructions

Description	Ident-No.
Magnetic sensor set, obtaining:	18210
- 2 sensors, Reed NC, Type P8S-GESNX	
- 1 mounting rail	
- 2 magnets	
Connecting cable, suitable for cable chain	
5 m	KL3186
10 m	KL3217
15 m	KL3216



OSP-E

Order Instructions **OSPE20** - **7** **0** **0** **02** - **00000** - **0** **00** **0** **0** **0**

Size	
20	Size 20
25	Size 25

Type of Actuator	
7	Vertical Belt Actuator with Integrated Ball Bearing Guide

Actuator Head	
0	Standard
1*	Tandem

Order Stroke
5 digits input in mm

Drive Shaft		
Motor Mounting Position see M		
0 A	Plain Shaft / Motor Standard	M
0 B	Plain Shaft / Motor 180° Standard	M
0 C*	Double Plain Shaft / Motor Standard	M
0 D*	Double Plain Shaft / Motor 180° Standard	M
0 2	Clamp Shaft / Motor Standard	M
0 3*	Clamp Shaft with Plain Shaft / Motor Standard *	M
0 4	Clamp Shaft / Motor 180° Standard	M
0 5*	Clamp Shaft with Plain Shaft / Motor 180° Standard *	M
0 6*	Hollow Shaft / Motor Standard *	M
0 7*	Hollow Shaft / Motor 180° Standard *	M

Special Drive Shaft on Request (8/9)

P-A4P017GB

OSP-E

Magnetic Sensors *		see page 165 ff
0	without	
2*	2pc. RST-S NC / M8 plug / Magnets	

Mounting Kit for Motor and Gear *			
Size		20	25
A3	SMx82 xx xx 8 14 ...	x 2	x 2
A7	PS60	x 2	x 1
C0	LP050 / PV40-TA	x 1	
C1	LP070 / PV60-TA	x 2	x 1

X¹: Kit for **Drive Shaft** with Clamp Shaft (02 / 03 / 04 / 05)

X²: Kit for **Drive Shaft** with Plain Shaft (0A / 0B / 0C / 0D)

Info: Motor and Gear Mounting Dimensions see page 191

Niro	
0	Standard
1*	Niro Screws

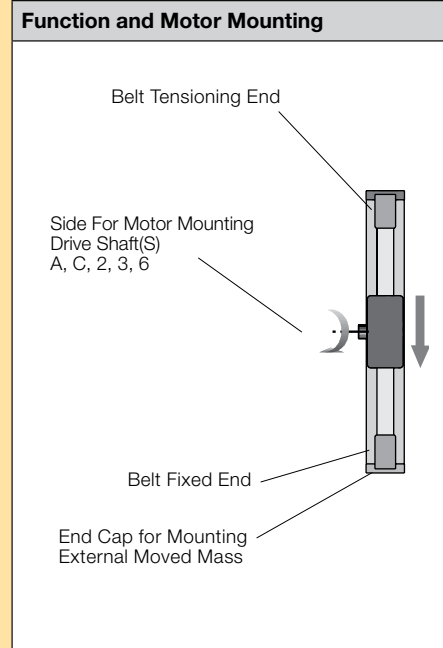

Accessories - please order separately	
Description	Page
Motor Mounting	135
Multi-Axis System for Actuators	177 ff

* Option

P-A4P017GB

OSP-E

P-A4P017GB

OSP-E

OSP-E..B Belt Actuator with Internal Plain Bearing Guide



Content

Description	Page
Overview	40
Technical Data	43
Dimensions	48
Order Instructions	50

P-A4P017GB
OSP-E

Belt actuator with Internal Plain Bearing Guide for Point-to-Point Applications

A completely new generation of actuators which can be integrated into any machine layout neatly and simply.

Advantages

- Precise Path and Position Control
- High Speed Operation
- Easy Installation
- Low Maintenance
- Ideal for Precise Point-to-Point Applications

Features

- Integrated Drive and Guidance System
- Tandem Configuration with Increased Carrier Distance for Higher Moment Supports
- Long Available Strokes
- Complete Motor and Control Packages
- Diverse Range of Accessories and Mountings
- Bi-Parting and Special Options Available

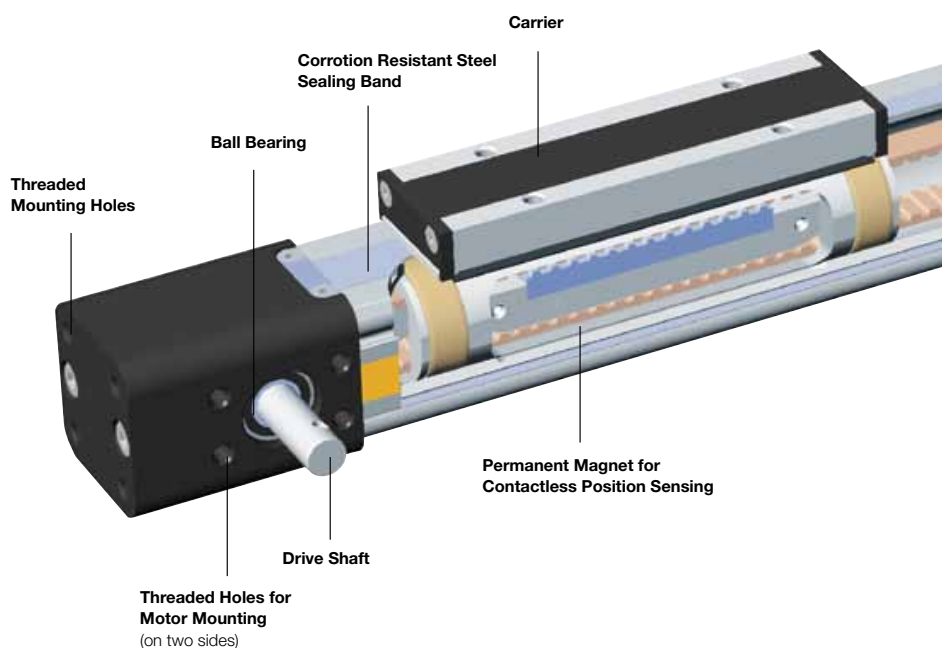
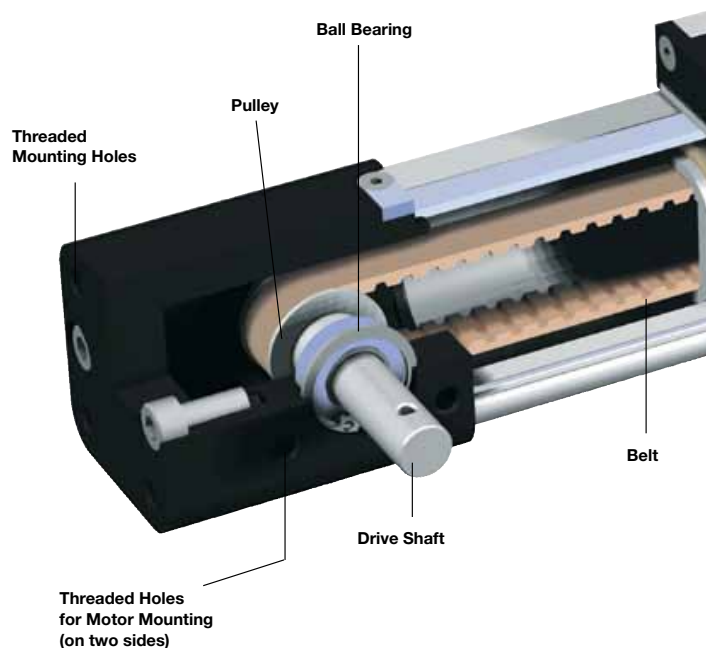

P-A4P017GB
OSP-E

The System Concept

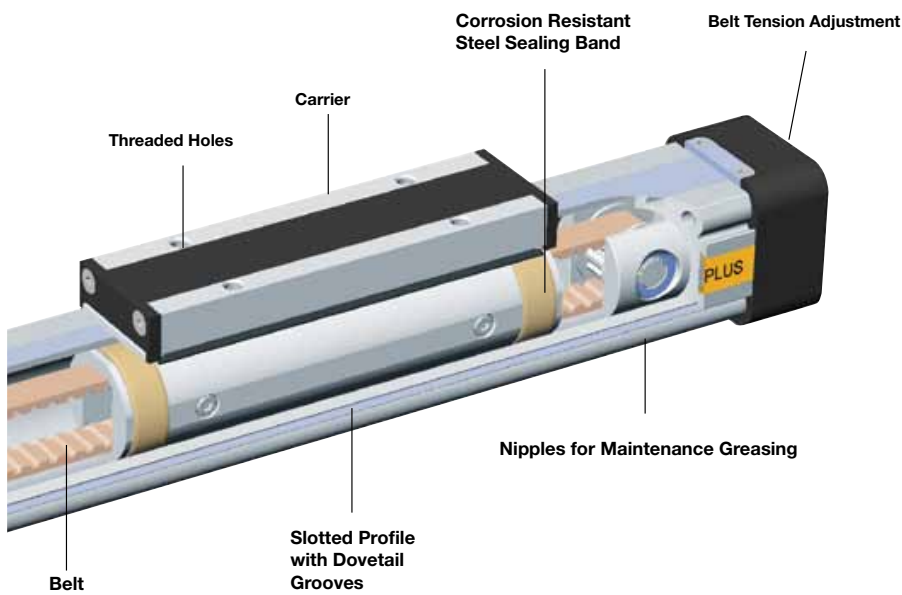
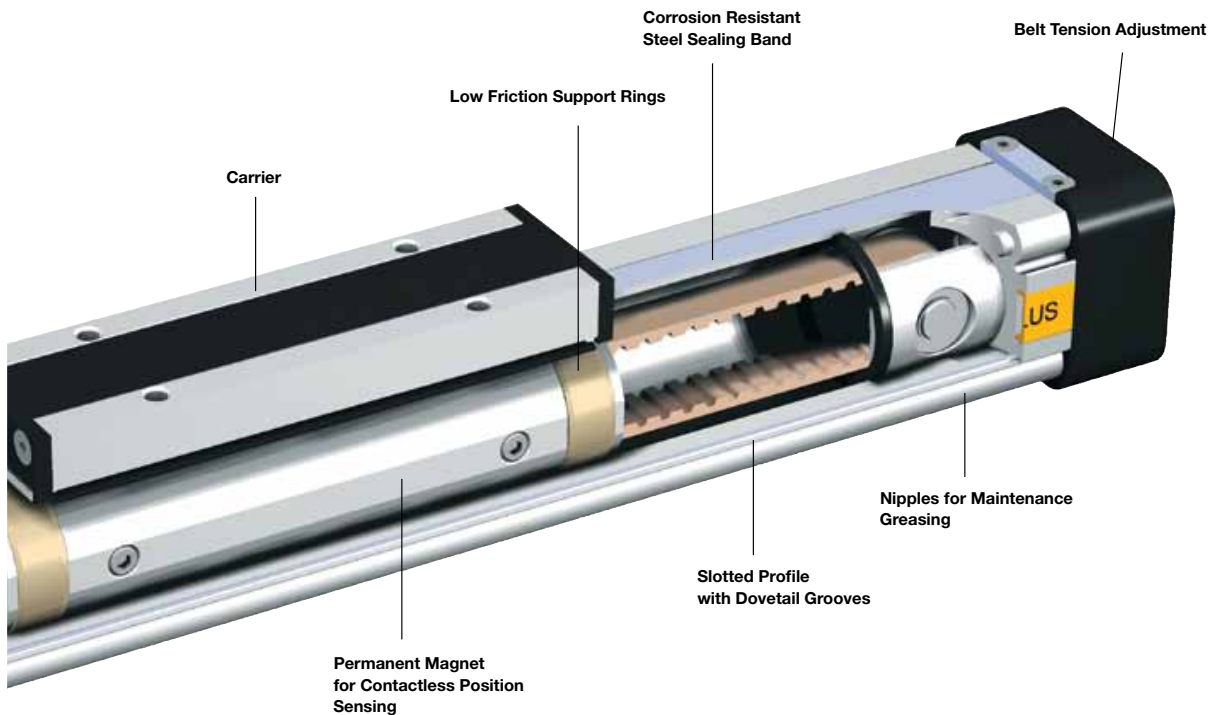

POWERSLIDE
Roller bearing precision guidance for smooth travel and high dynamic or static loads.



PROLINE
The compact aluminium roller guide for high loads and velocities.



Tandem configuration with increased carrier distance for higher moment supports.
Bi-parting version for precise synchronized movements



The dovetailed mounting rails of the new actuator expand its function into that of a universal system carrier. Modular system components are simply clamped on.

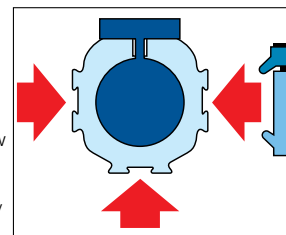

OSP-E..B Belt Actuator with internal Plain Bearing Guide

STANDARD VERSIONS

OSP-E..B

Carrier with internal guidance and magnet packet for contactless position sensing. Dovetail profile for mounting of accessories and the actuator itself.

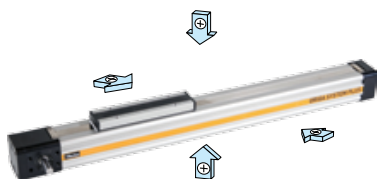

Drive Shaft Versions

- Plain shaft or
- Double plain shaft (Option)
e.g. to drive two actuators in parallel.



OPTIONS

Tandem

For higher moment support.



Bi-parting

For perfectly synchronised bi-parting movements.



Accessories

Motor Mounting

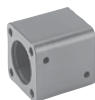

End Cap Mounting

For end-mounting of the actuator.



Profile Mounting

For supporting long actuators or mounting the actuator on the dovetail grooves.



Clevis Mounting

Carrier with tolerance and parallelism compensation to drive external linear guides.

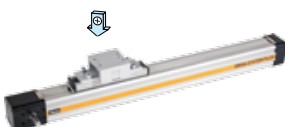

Inversion Mounting

The inversion mounting, mounted on the carrier, transfers the driving force to the opposite side, e.g. for dirty environments.

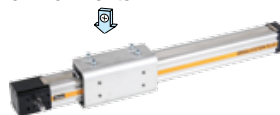

Magnetic Sensors Series RST and EST

For contactless position sensing of end stop and intermediate carrier positions.



P-A4P017GB

OSP-E

OSP-E..B Belt Actuator with Internal Plain Bearing Guide - Size 25, 32, 50

Standard Version

- Standard carrier with internal plain bearing guide
- Dovetail profile for Mounting of Accessories and the Actuator itself
- Position of Drive Shafts



Options

- Tandem-Version
- Bi-parting Version for Synchronised Movements
- Drive shaft with double plain shaft

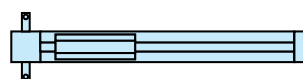

Characteristics

	Symbol	Unit	Description
General Features			
Series			OSP-E..BHD
Name			Belt Actuator with Internal Plain Bearing Guide
Mounting			see drawings
Temperature Range	ϑ_{min} ϑ_{max}	°C	-30 +80
Weight (mass)		kg	see table
Installation			see table
Material	Slotted Profile		Extruded Anodized Aluminium
	Belt		Steel-corded Polyurethane
	Pulley		Aluminium
	Guide Bearings		Low Friction Plastic
	Sealing Band		Hardened Corrosion Resistant Steel
	Screws, Nuts		Zinc Plated Steel
	Mountings		Zinc Plated Steel and Aluminium
Encapsulation Class		IP	54

Weight (mass) and Inertia

Series	Weight (mass) [kg]			Inertia [$\times 10^{-6}$ kgm ²]	
	at stroke 0 m	ad per metre stroke	moving mass	at stroke 0 m	ad per metre stroke
OSP-E25B	0.9	1.6	0.2	25	6.6
OSP-E32B	1.9	3.2	0.4	43	10
OSP-E50B	5.2	6.2	1.0	312	45
OSP-E25B*	1.2	1.6	0.5	48	6.6
OSP-E32B*	2.3	3.2	0.8	83	10
OSP-E50B*	6.3	6.2	2.1	585	45

*Version: Tandem and Bi-parting (Option)



Installation Instructions

Use the threaded holes in the end cap for mounting the actuator. See if profile mountings are needed using the maximum allowable unsupported length graph on page 45.

At least one end cap must be secured to prevent axial sliding when profile mounting is used. When the actuator is moving an externally guided load, the compensation must be used.

The actuators can be fitted with the standard carrier mounting facing in any direction. To prevent contamination such as fluid ingress, the actuator should be fitted with its sealing band facing downwards. The inversion mounting can be fitted to transfer the driving force to the opposite side.

Maintenance

All moving parts are long-term lubricated for a normal operational environment. Parker recommends a check and lubrication of the actuator, and if necessary a change of the belt and wear parts, after an operation time of 12 months of operation or 3 000 km travel of distance.

Additional greasing is easily done by using nipples in the slotted profile. Please refer to the operating instructions supplied with the actuator.

First service start-up

The maximum values specified in the technical data sheet for the different products must not be exceeded. Before taking the actuator as a machine into service, the user must ensure the adherence to the EC Machine Directive 2006/42/EG.



Sizing of Actuator

The following steps are recommended for selection:

1. Required acceleration see table
2. Required torque is shown on page 46 and 47.
3. Check that maximum values in the table 3 are not exceeded .
4. Drive shaft by using table T2. (Pay attention to note under table) If value is lower than required, overview the moving profile or select if possible a bigger unit.
5. Before sizing and specifying the motor, the average torque must be calculated using the cycle time of the application.
6. Check that the maximum allowable unsupported length is not exceeded (see on page 45).

Performance Overview

T1

Characteristics	Unit	Description			
Size		OSP-E 25B	OSP-E 32B	OSP-E 50B	
Max. Speed	[m/s]	2	3	5	
Linear Motion per Revolution, Drive Shaft	[mm]	60	60	100	
Max. rpm Drive Shaft	[min ⁻¹]	2,000	3,000	3,000	
Max. Effective Action Force F _A at Speed	< 1 m/s	[N]	50	150	425
	1 - 2 m/s	[N]	50	120	375
	> 2 m/s	[N]	-	100	300
No-load Torque	[Nm]	0.4	0.5	0.6	
Max. Acceleration/Deceleration	[m/s ²]	10	10	10	
Repeatability	[mm/m]	±0.05	±0.05	±0.05	
Max. Stroke Length OSP-E..B	[mm]	3,000	5,000	5,000	
Max. Stroke Length OSP-E..B*	[mm]	2 x 1,500	2 x 2,500	2 x 2,500	

*Bi-parting version

Maximum Permissible Torque on Drive Shaft Speed/Stroke

T2

OSP-E-25B				OSP-E-32B				OSP-E-50B			
Speed [m/s]	Torque [Nm]	Stroke [m]	Torque [Nm]	Speed [m/s]	Torque [Nm]	Stroke [m]	Torque [Nm]	Speed [m/s]	Torque [Nm]	Stroke [m]	Torque [Nm]
1	0.9	1	0.9	1	2.3	1	2.3	1	10.0	1	10.0
2	0.9	2	0.9	2	2.0	2	2.3	2	9.5	2	10.0
		3	0.9	3	1.8	3	2.3	3	9.0	3	9.0
						4	2.3	4	8.0	4	7.0
						5	1.8	5	7.5	5	6.0

Important: The maximum permissible torque on the drive shaft is the lowest value of the speed- or stroke-dependent torque value.

Example above: OSP-E32B stroke 2 m, required speed 3 m/s; From table T2: speed 3 m/s gives 1.8 Nm and stroke 2 m gives 2.3 Nm. Max. torque for this application is 1.8 Nm.

Maximum Permissible Loads

T3

Series	Max. applied	Max. moments [Nm]		
	load F _z [N]	M _x	M _y	M _z
OSP-E25B	160	2	12	8
OSP-E32B	300	8	25	16
OSP-E50B	850	16	80	32
OSP-E..B Bi-partional	The maximum load F must be equally distributed among the two carriers.			

Combined Loads

If the actuator is subjected to several forces, loads and moments at the same time, the maximum load is calculated with the equation shown here. The maximum permissible loads must not be exceeded.

Equation of Combined Loads

$$\frac{F_y}{F_y(\max)} + \frac{F_z}{F_z(\max)} + \frac{M_x}{M_x(\max)} + \frac{M_y}{M_y(\max)} + \frac{M_z}{M_z(\max)} \leq 1$$

The total of the loads must not exceed >1 under any circumstances.

Forces, Loads and Moments

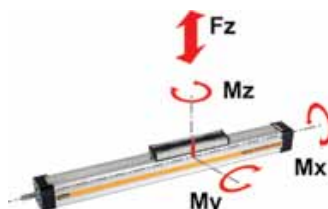

M = F · l [Nm]
M_x = M_x statically + M_x dynamically
M_y = M_y statically + M_y dynamically
M_z = M_z statically + M_z dynamically

The distance l (lx, ly, lz) for calculation of moments relates to the centre axis of the actuator.

Stroke Length

The stroke lengths of the actuators are available in multiples of 1 mm up to max.

OSP-E25B: 3 m / 2 x 1.5 m *

OSP-E32B: 5 m / 2 x 2.5 m *

OSP-E50B: 5 m / 2 x 2.5 m *

* Version: Bi-partional

Other stroke lengths are available on request.

The end of stroke must not be used as a mechanical stop. Allow an additional safety clearance at both ends equivalent to the linear movement of one revolution of the drive shaft.

The use of an AC motor with frequency converter normally requires a larger safety clearance than that required for servo systems. For advise, please contact your local Parker technical support department.

Maximum Permissible Unsupported Length – Placing of Profile Mounting

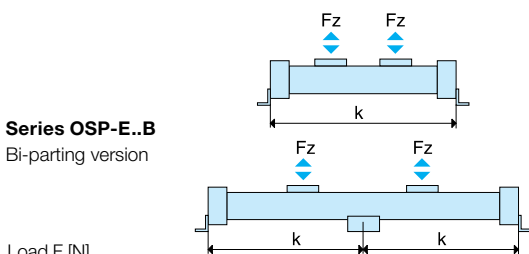
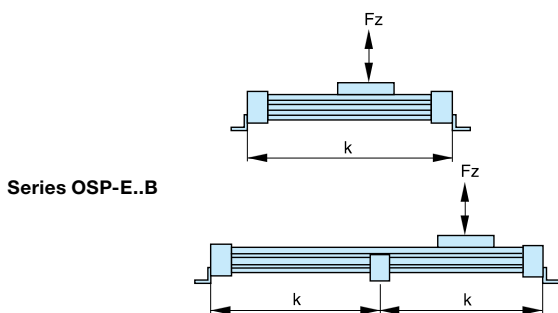

k = Maximum permissible distance between mountings/mid-section support for a given load F.

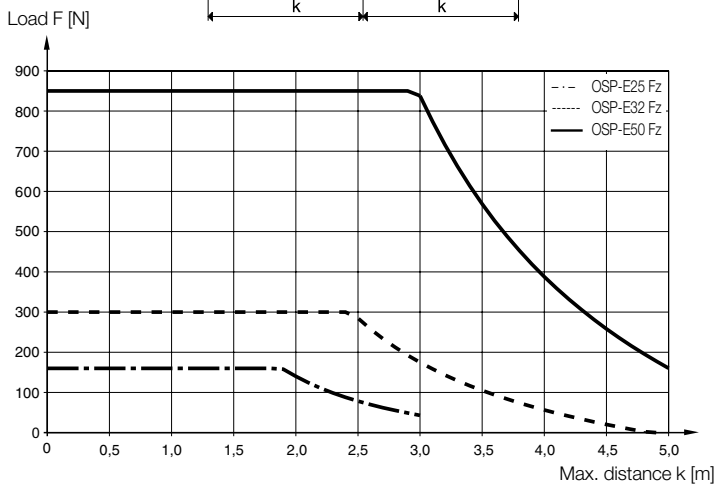

(Up to the curve in the above graph the deflection will be max. 0.2 % of distance k)

Mounting on the Drive Shaft

Do not expose the drive shaft to uncontrolled axial or radial forces when mounting coupler or pulley, a steadying block should be used.

Pulley

Minimum allowable number of teeth Z (AT5) at maximum applied torque.

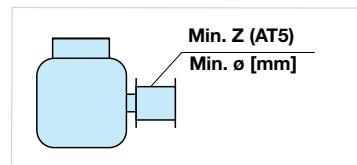

Series	Min. Z	Min ø
OSP-E25B	24	38
OSP-E32B	24	38
OSP-E50B	36	57

Distance / Time Graph

Using the required travel distance and total time, the adjacent graphs show the required acceleration based on maximum speed.

The graphs assume that acceleration and deceleration are equal. Please note that specifying non-essential high acceleration or short cycle time will result in an oversized motor.

Max. Speed 1 m/s

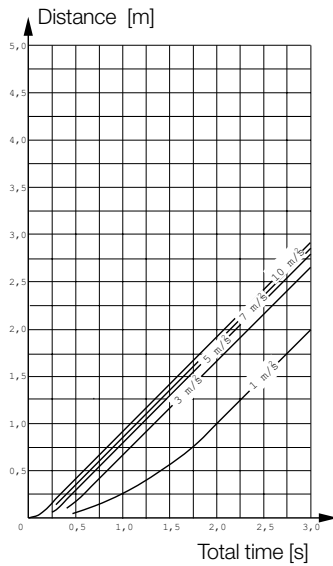

Max. Speed 2 m/s

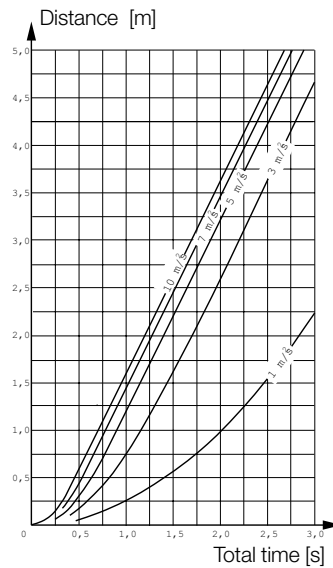

Max. Speed 3 m/s

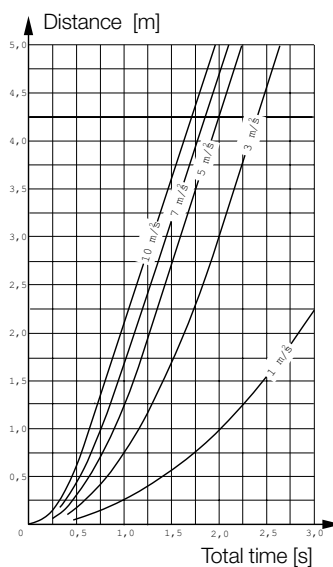

Max. Speed 5 m/s

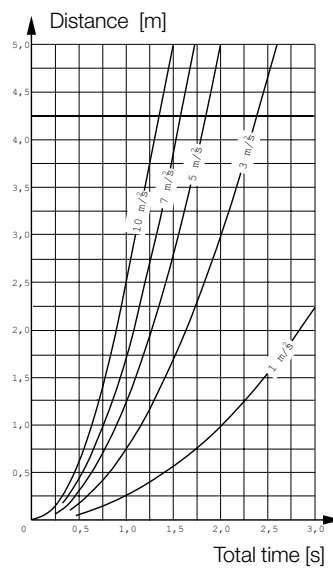

Required Torque / Mass

Using the known mass, the direction of the application and the required acceleration from the distance-time graphs, the actuator can be sized and the required torque is shown in the adjacent graphs.
 Mass in graphs = Load + moving mass of the actuator (according to the weight chart on data sheet 43 ff).

Please note: When using an additional guide, please add the mass of the carriage to the total moving mass.

Size OSP-E25B, Horizontal Application

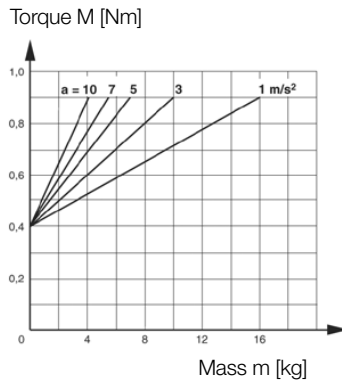

Size OSP-E25B, Vertical Application

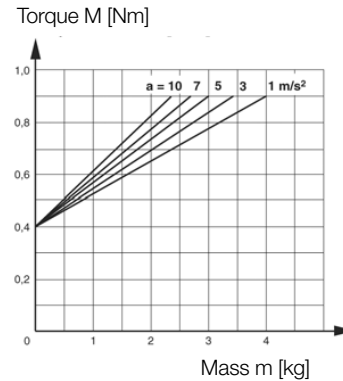

Size OSP-E32B, Horizontal Application

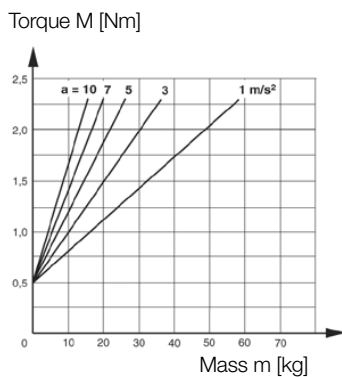

Size OSP-E32B, Vertical Application

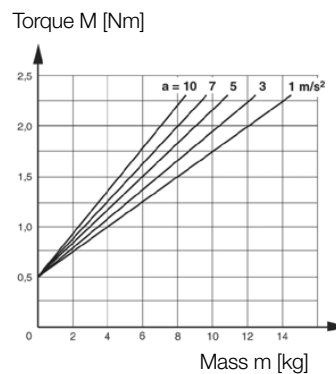

Size OSP-E50B, Horizontal Application

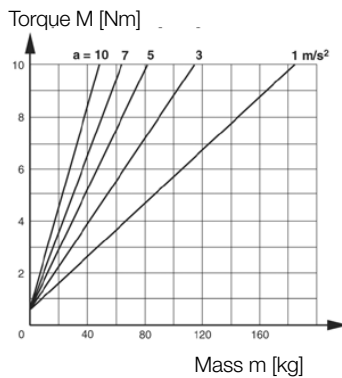

Size OSP-E50B, Vertical Application

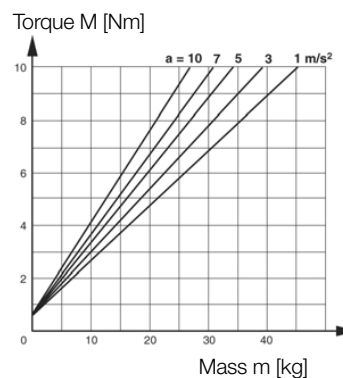

P-A4P017GB

OSP-E

OSP-E Belt Actuator with Internal Plain Bearing Guide

OSP-E..B - Basic Unit

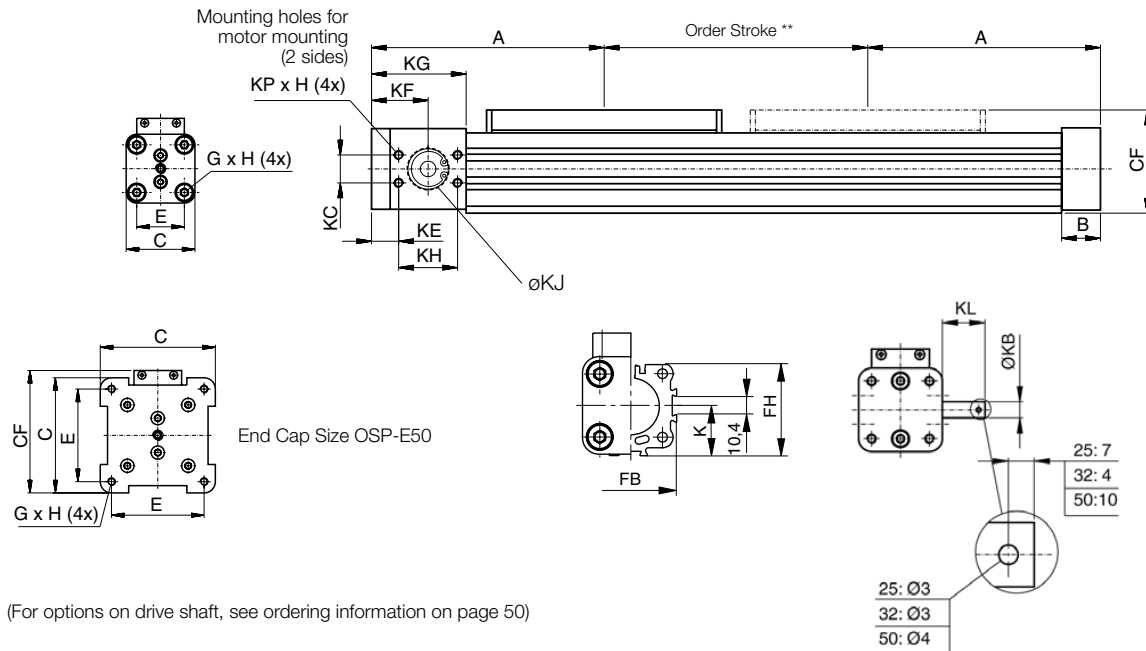

(For options on drive shaft, see ordering information on page 50)

* **Note:** The mechanical end position must not be used as a mechanical end stop. Allow an additional safety clearance at both ends equivalent to the linear movement of one revolution of the drive shaft, but at least 100 mm. Order stroke = required travel + 2 x safety distance. The use of an AC motor with frequency converter normally requires a larger safety clearance than that required for servo systems. For further information please contact your local Parker representative.

Option-Tandem

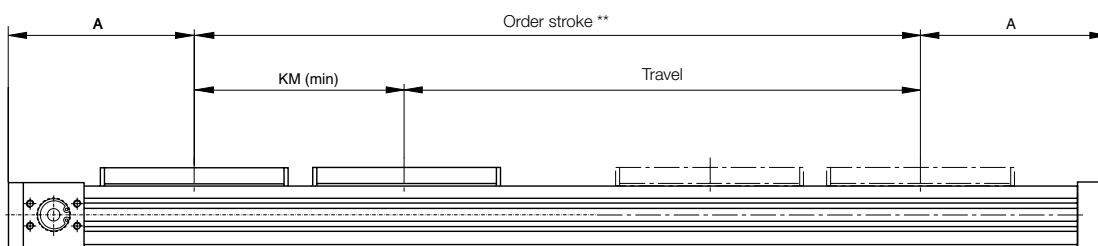

** Order stroke = required travel + KM min + 2 x safety distance

Option-Bi-parting

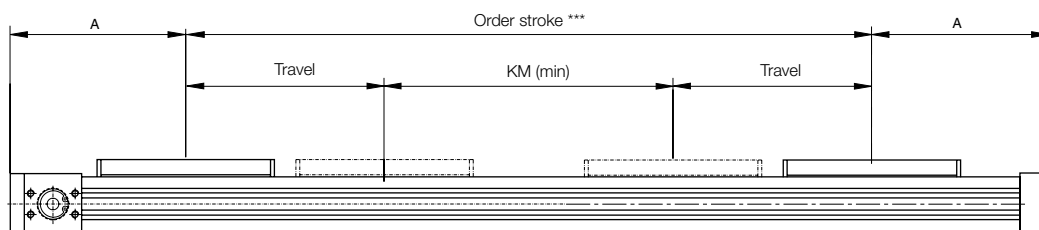

*** Order stroke = 2 x required travel + KM min + 2 x safety distance



P-A4P017GB

OSP-E

OSP-E Belt Actuator with Internal Plain Bearing Guide

Standard Carrier

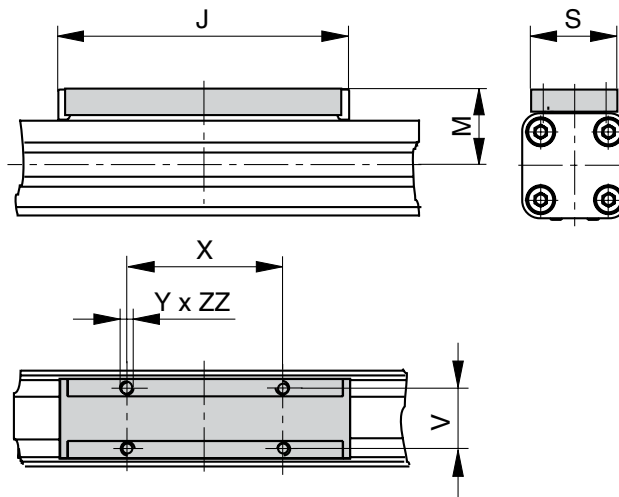

Dimension Table [mm]

Series	A	B	C	E	G x H	J	K	M	S	V	X	Y	CF
OSP-E25B	125	22	41	27	M5 x 10	117	21.5	31	33	25	65	M5	52.5
OSP-E32B	150	25	52	36	M6 x 12	152	28.5	38	36	27	90	M6	66.5
OSP-E50B	200	25	87	70	M6 x 12	200	43.0	49	36	27	110	M6	92.5

Series	FB	FH	KB	KC	KE	KF	KG	KH	KJ	KL	KM _{min}	KM _{recc.}	KP x H	ZZ
OSP-E25B	40	39.5	10 ₆	15	22.0	37.0	57	30	19 ^{H7}	24	130	190	M5 x 10	8
OSP-E32B	52	51.7	10 ₆	18	17.5	36.5	61	38	26 ^{H7}	26	170	230	M6 x 12	10
OSP-E50B	76	77.0	16 _{h8}	32	23.5	48.5	85	50	40 ^{H7}	34	220	320	M8 x 16	10

OSP-E

Order Instructions OSPE25 - 0 0 0 0 0 - 00000 - 0 0 0 0 0 0

Size of Actuator	
25	Size 25
32	Size 32
50	Size 50

Type of Actuator	
0	Belt Actuator with Internal Plain Bearing Guide

Carriage	
0	Standard
1*	Tandem
2*	Bi-parting

Drive Shaft / Motor Mounting Position		
0	Plain Shaft / Motor Standard	
1	Plain Shaft / Motor 180° Standard	
2*	Double Plain Shaft	

Gear Mounting*				
Size		25	32	50
0	without	x	x	x
1	LP050 i = 5	x	x	
2	LP050 i = 10	x	x	
3	LP070 i = 3		x	x
4	LP070 i = 5		x	x
5	LP070 i = 10		x	x

Info: For gears the mounting kit of the motor must be specified.
 LP050: A0, A1, A2
 LP070: A1, A2, A3

Order Stroke
5 digits input in mm

Mounting Kit for Motor and Gear				
Size		25	32	50
0 -	without	x	x	x
A 0	SY563T	x	x	
A 1	SY873T	x	x	x
A 2	SMx60 xx xxx 8 11 ...	x	x	
A 3	SMx82 xx xx 8 14 ...		x	x
A 4	SMx100 xx xx 5 19...			x
A 7	PS60		x	x
C 0	LP050 / PV40-TA	x	x	
C 1	LP070 / PV60-TA		x	x

Info: Motor and gear mounting dimensions see page 191

Guide Position		
0	Standard	
1	180° Standard	
0	Standard	
1	180° Standard	
0	Standard	
1	180° Standard	

External Guide / Carriage Mounting* see page 99 ff	
0	without
6	PL Proline
E	PS Power Slide 25/25
F	PS Power Slide 25/35, 32/35
G	PS Power Slide 25/44, 32/44
H	PS Power Slide 50/60
I	PS Power Slide 50/76
M	Inversion
R	Compensation
S	Compensation Low Back Lash

Niro	
0	Standard
1*	Niro

Accessories - please order separately	
Description	Page
Motor Mounting	136 ff
Multi-Axis System for Actuators	177 ff

Magnetic Sensors * see page 165 ff

0	without
1	1 pc. RST-K 2NO / 5 m Cable
2	1 pc. RST-K 2NC / 5 m Cable
3	2 pc. RST-K 2NC / 5 m Cable
4	2 pc. RST-K 2NC, 1 pc. RST-K 2NO / 5 m Cable
5	1 pc. RST-S 2NO / M8 plug
6	1 pc. RST-S 2NC / M8 plug
7	2 pc. RST-S 2NC / M8 plug
8	2 pc. RST-S 2NC, 1 pc. RST-S 2NO / M8 plug
A	1 pc. EST-S NPN / M8 plug
B	2 pc. EST-S NPN / M8 plug
C	3 pc. EST-S NPN / M8 plug
D	1 pc. EST-S PNP / M8 plug
E	2 pc. EST-S PNP / M8 plug
F	3 pc. EST-S PNP / M8 plug

Profile Mounting * see pages 147 ff and 161 ff

0	without
1	1 Pair Type E1
2	1 Pair Type D1
3	1 Pair Type MAE
4	2 Pair Type 1
5	2 Pair Type D1
6	2 Pair Type MAE
7	3 Pair Type 1
8	3 Pair Type D1
9	3 Pair Type MAE
K	1 Pair Type E2
L	1 Pair Type E3
M	1 Pair Type E4
N	2 Pair Type E2
P	2 Pair Type E3
Q	2 Pair Type E4
R	3 Pair Type E2
S	3 Pair Type E3
T	3 Pair Type E4

End Cap Mounting * see pages 147 and 161 ff

0	without
1	1 Pair Type A1 (size 25 and 32) or C1 (size 50)
2	1 Pair Type A2 (size 25 and 32) or C2 (size 50)
3	1 Pair Type A3 (size 25 and 32) or C3 (size 50)
4	1 Pair Type B1 (size 25 and 32) or C4 (size 50)
5	1 Pair Type B4 (size 25 and 32)

* Option

P-A4P017GB

OSP-E

P-A4P017GB

OSP-E

OSP-E..SB Ball Screw Actuator with Internal Plain Bearing Guide



Content

Description	Page
Overview	54
Technical Data	57
Dimensions	62
Order Instructions	64

P-A4P017GB
OSP-E

Ball Screw Actuator with Internal Plain Bearing Guide for High Accuracy Applications

A completely new generation of actuators which can be integrated into any machine layout neatly and simply.

Advantages

- Accurate Path And Position Control
- High Force Output
- Easy Installation
- Excellent Slow Speed Characteristics
- Ideal for Precise Traverse Operations (e.g. Machine Feeds) and Lifting Applications

Features

- Integrated Drive and Guidance System
- Complete Motor and Control Packages
- Diverse Range of Accessories and Mountings
- Optimal Screw Pitches (5, 10, 25 mm)

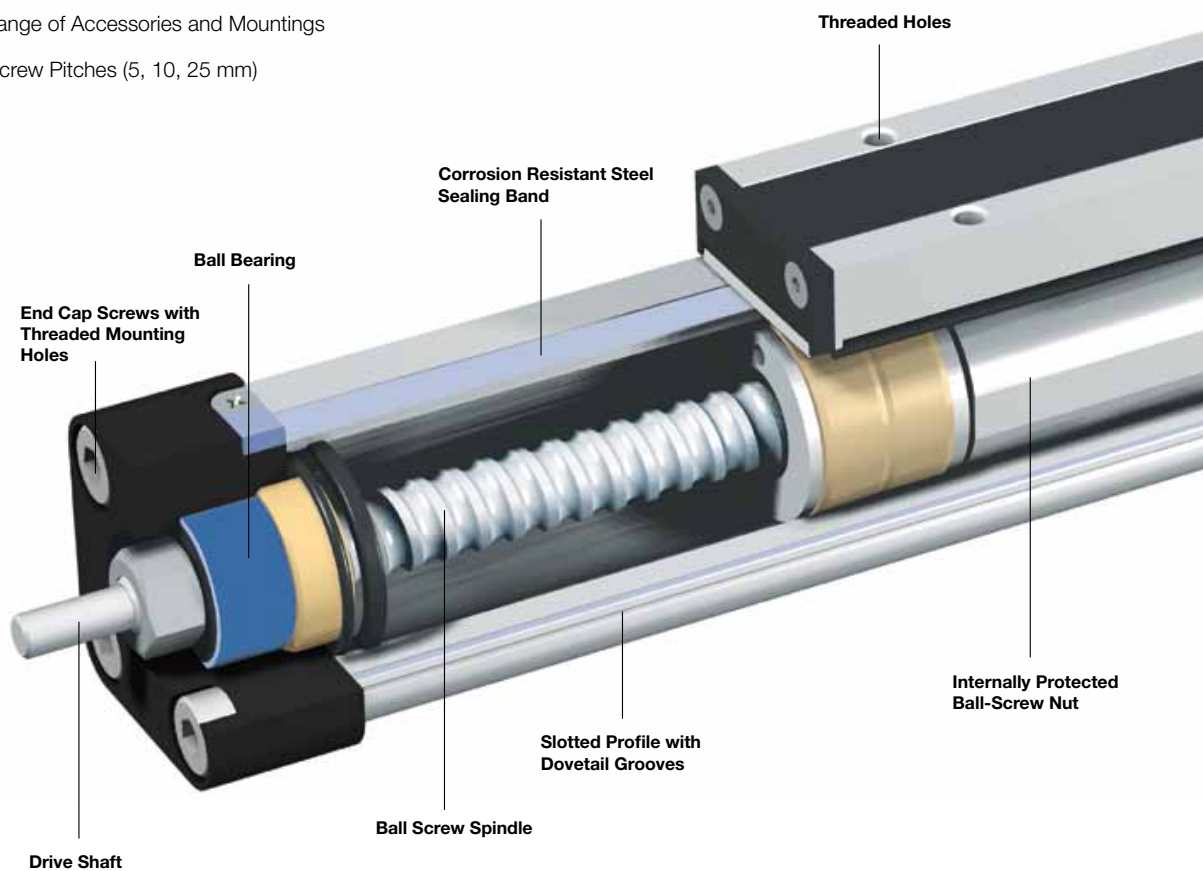

P-A4P017GB
OSP-E

The System Concept

Clean Room-Version
 certified to DIN EN ISO 14644-1



Low Friction Support Rings

Carrier

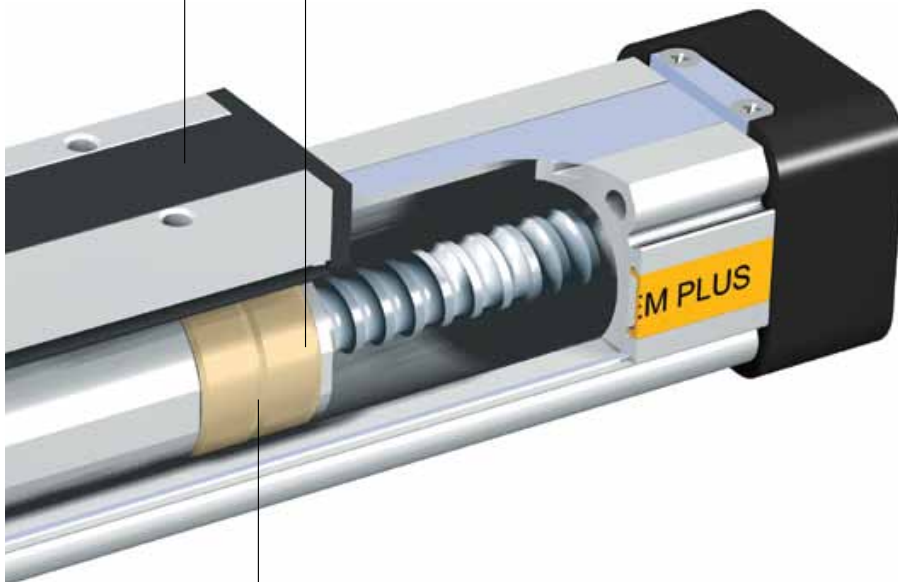

Permanent Magnet for
 Contactless Sensing

SLIDELINE

Combination with
 linear guides
 provides for
 heavier loads.



POWERSLIDE

Roller bearing
 precision guidance for
 smooth travel and high
 dynamic
 or static loads.



PROLINE

The compact
 aluminium roller guide
 for high loads and
 velocities.



Heavy Duty guide

HD linear guides
 for heavy duty applica-
 tions

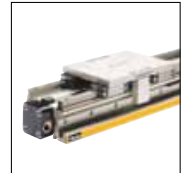

SFI-plus

displacement
 measuring system



The dovetailed mounting rails
 of the new actuator expand its
 function into that of a universal
 system carrier.
 Modular system components are
 simply clamped on.

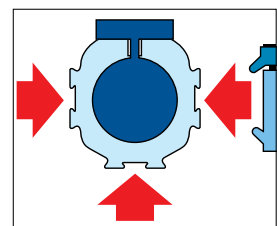

P-A4P017GB

OSP-E

Options and Accessories

OSP-E..SB Ball Screw Actuator with internal Plain Bearing Guide

Standard Version OSP-E..SB

Standard carrier with internal guidance and integrated magnet set for contactless position sensing. Dovetail profile for mounting of accessories and the actuator itself.

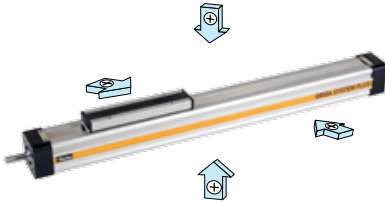

Accessories

Motor Mountings



Inversion Mounting

The inversion mounting, mounted on the carrier, transfers the driving force to the opposite side, e.g. for dirty environments.

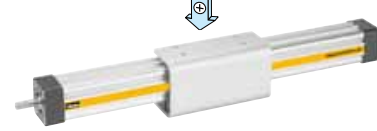

Ball Screw Pitch

The ball screws spindles are available in various pitches:
OSP-E25SB: 5 mm
OSP-E32SB: 5, 10 mm
OSP-E50SB: 5, 10, 25 mm

End Cap Mounting

For end-mounting of the actuator.



Magnet Sensor

For contactless position sensing of end stop and intermediate carrier positions.



Options

Tandem

For higher moment support.



Profile Mounting

For supporting long actuators or mounting the actuator on the dovetail grooves.



Measuring System - SFI PLUS

Incremental measuring system with practically relevant resolution.



Clean Room

certified to DIN EN ISO 14644-1



Clevis Mounting

Carrier with tolerance and parallelism compensation to drive external linear guides.

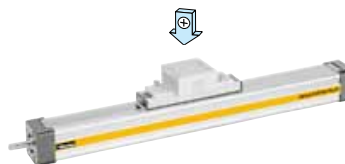

P-A4P017GB

OSP-E

OSP-E..SB Ball Screw Actuator with Internal Plain Bearing Guide - Size 25, 32, 50

Standard Versions:

- Standard Carrier with Internal Plain Bearing Guide
- Dovetail Profile for Mounting of Accessories and the Actuator Itself
- Pitches of Ball Screw Spindle

Type OSP-E25: 5 mm

Type OSP-E32: 5, 10 mm

Type OSP-E50: 5, 10, 25 mm

Options:

- Tandem-Version
- Clean room-version, according to DIN EN ISO 14644-1
- Displacement Measuring System SFI-plus



Characteristics

	Symbol	Unit	Description
General Features			
Series			OSP-E..SB
Name			Ball Screw Actuator with Internal Plain Bearing Guide
Mounting			see drawings
Temperature Range	ϑ_{\min} ϑ_{\max}	°C	-20 +80
Weight (mass)		kg	see table
Installation			in any position
Material	Slotted Profile		Extruded Anodized Aluminium
	Ball Screw		Hardened Steel
	Ball Screw Nut		Hardened Steel
	Guide Bearings		Low Friction Plastic
	Sealing Band		Hardened, Corrosion Resistant Steel
	Screws, Nuts		Zinc Plated Steel
	Mountings		Zinc Plated Steel and Aluminium
Protection Class		IP	54

Weight (mass) and Inertia

Series	Weight (mass) [kg]			Inertia [$\times 10^{-6}$ kgm ²]				
	at stroke 0 m	Add per metre stroke	Moving mass	at stroke 0 m	at stroke 0 m	per kg mass 5 mm* 10 mm* 25 mm*		
OSP-E25SB	0.8	2.3	0.2	2.2	11	0.6	-	-
OSP-E32SB	2.0	4.4	0.4	8.4	32	0.6	2.5	-
OSP-E50SB	5.2	9.4	1.2	84.0	225	0.6	2.5	15.8

*pitch

Installation Instructions

Use the threaded holes in the free end cap and a profile mounting close to the motor end for mounting the actuator.

See if profile mountings are needed using the maximum permissible unsupported length graph on page 59. At least one end cap must be secured to prevent axial sliding when Profile Mounting is used. When the actuator is moving an externally guided load, the Compensation must be used (see page 109).

The actuators can be fitted with the standard carrier mounting facing in any direction.

To prevent contamination such as fluid ingress, the actuator should be fitted with its sealing band facing downwards.

The inversion mounting can be fitted to transfer the driving force to the opposite side.

Maintenance

All moving parts are long-term lubricated for a normal operational environment. Parker recommends a check and lubrication of the actuator, and if necessary a change of wear parts, after an operation time of 12 months or 3000 km travel of distance. Please refer to the operating instructions supplied with the actuator.

First service start-up

The maximum values specified in the technical data sheet for the different products must not be exceeded. Before taking the actuator as a machine into service, the user must ensure the adherence to the EC Machine Directive 2006/42/EG.



Sizing of Actuator

The following steps are recommended for selection :

1. Recommended maximum acceleration is shown in graphs on page 61.
2. Required torque is shown in graphs
3. Check that maximum values in the adjacent charts are not exceeded.
4. When sizing and specifying the motor, the RMS-average torque must be calculated using the cycle time of the application.
5. Check that the maximum allowable unsupported length is not exceeded (see on page 59 ff)

Performance Overview

Characteristics	Unit	Description					
		OSP-E 25B		OSP-E 32B		OSP-E 50B	
Size							
Pitch	[mm]	5	5	10	5	10	25
Max. speed	[m/s]	0.25	0.25	0.5	0.25	0.5	1.25
Linear motion per revolution drive shaft	[mm]	5	5	10	5	10	25
Max. rpm. drive shaft	[min ⁻¹]	3000	3000		3000		
Max. effective action force F _A	[N]	250	600	600	1500		
corresponding torque on drive shaft	[Nm]	0.35	0.75	1.3	1.7	3.1	7.3
No-load torque	[Nm]	0.2	0.2	0.3	0.3	0.4	0.5
Max. allowable torque on drive shaft	[Nm]	0.6	1.5	2.8	4.2	7.5	20
Repeatability	[mm]	±0.05	±0.05		±0.05		
Max. Standard stroke length	[mm]	1100	2000		3200		

Forces, Loads and Moments

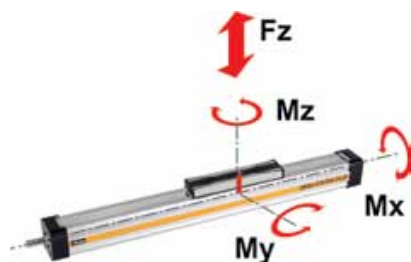

$M = F \cdot l$ [Nm]
 $M_x = M_{x \text{ statically}} + M_{x \text{ dynamically}}$
 $M_y = M_{y \text{ statically}} + M_{y \text{ dynamically}}$
 $M_z = M_{z \text{ statically}} + M_{z \text{ dynamically}}$

The distance l (lx, ly, lz) for calculation of moments relates to the centre axis of the actuator.

Maximum Permissible Loads

Series	Max. applied load [N]	Max. moments [Nm]		
		F _z , F _y	M _x	M _y
OSP-E25SB	500	2	12	8
OSP-E32SB	1200	8	25	16
OSP-E50SB	3000	16	80	32

Combined Loads

If the actuator is subjected to several forces, loads and moments at the same time, the maximum load is calculated with the equation shown here. The maximum permissible loads must not be exceeded.

Equation of Combined Loads

$$\frac{F_y}{F_y(\text{max})} + \frac{F_z}{F_z(\text{max})} + \frac{M_x}{M_x(\text{max})} + \frac{M_y}{M_y(\text{max})} + \frac{M_z}{M_z(\text{max})} \leq 1$$

The total of the loads must not exceed >1 under any circumstances.

P-A4P017GB

OSP-E

Maximum Permissible Unsupported Length

Stroke Length

The stroke lengths of the actuators are available in multiples of 1 mm up to above maximum stroke lengths.

OSP-E25SB: max. 1100 mm

OSP-E32SB: max. 2000 mm

OSP-E50SB: max. 3200 mm

Other stroke lengths are available on request.

The end of stroke must not be used as a mechanical stop. Allow an additional safety clearance of minimum 25 mm at both ends.

The use of an AC motor with frequency converter normally requires a larger safety clearance than that required for servo systems. For advise, please contact your local Parker technical support department.

Maximum Permissible Unsupported Length – Placing of Profile Mounting

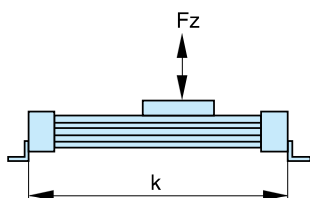

$k =$ Maximum permissible distance between mountings/mid-section support for a given load F .

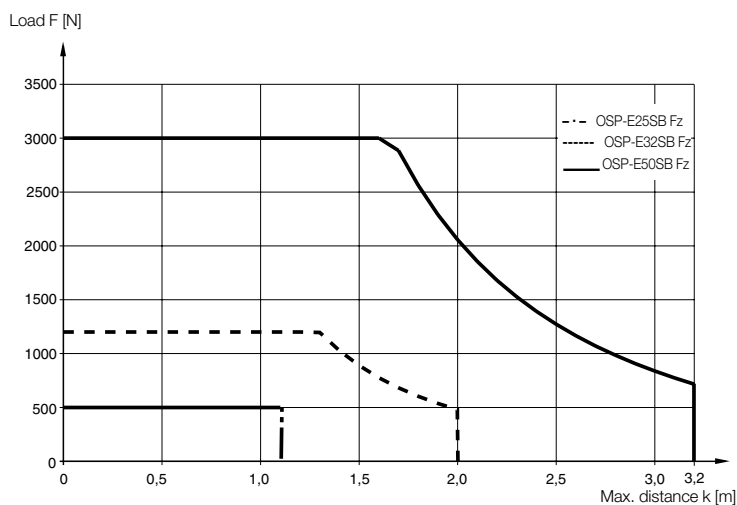
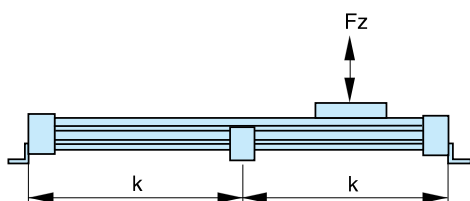

(Up to the curve in the above graph the deflection will be max. 0.2 % of distance k .)

Mounting on the Drive Shaft

Do not expose the drive shaft to uncontrolled axial or radial forces when mounting coupling or pulley, a steadying block should be used.

Pulleys

Minimum allowable number of teeth (AT5) and diameter of pulley at maximum applied torque.

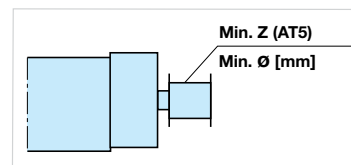

Series	Min. Z	Min Ø
OSP-E25B	24	38
OSP-E32B	24	38
OSP-E50B	36	57

P-A4P017GB

OSP-E

Maximum rpm/Stroke

At longer strokes the speed has to be reduced according to the adjacent graphs.

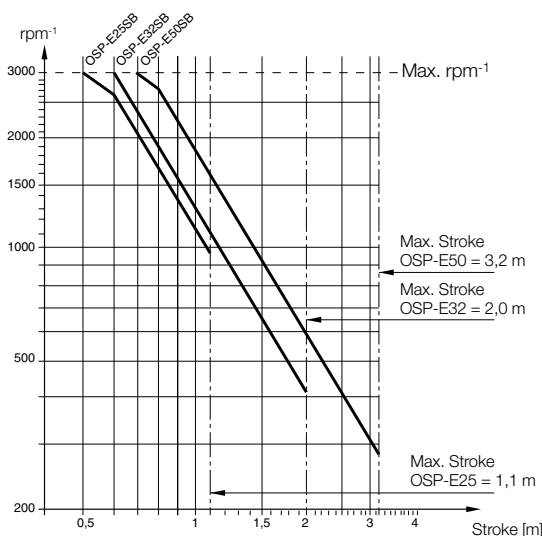

The maximum rpm shown in the graph, is 80% of the critical rpm.

Performance / Action Force

The performance to be expected depends on the maximum required actions force of the application. An increase of the action force will lead to a reduced performance.

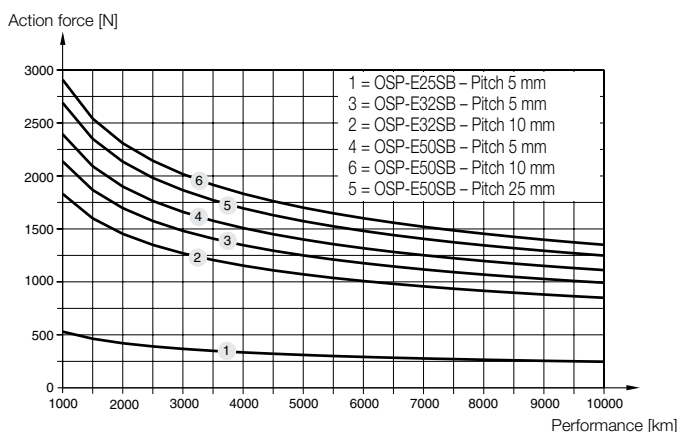

Distance / Time Graph

The adjacent graphs show travel distance and total time at maximum speed and recommended maximum acceleration. The graph assumes that acceleration and deceleration are equal.

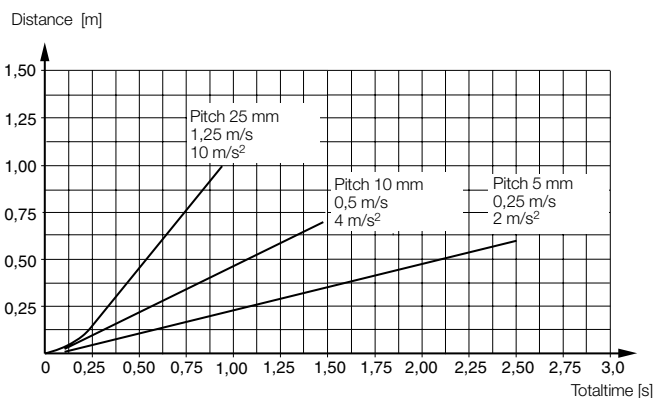

P-A4P017GB

OSP-E

Required Torque / Mass

Using the known mass, the direction of the application and the recommended acceleration, the actuator can be sized and the required torque is shown in the adjacent graphs.

Mass in graphs = Load + moving mass of the actuator according to the weight chart (see table on page 61).

Please mind: If an additional guide is used, mind the weight of the guide carriage.

**Size OSP-E25SB, Pitch 5mm
Acceleration 2 m/s²**

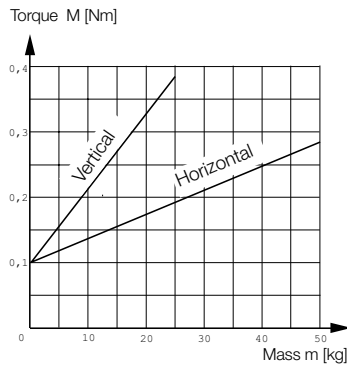

**Size OSP-E32SB, Pitch 5 mm
Acceleration 2 m/s²**

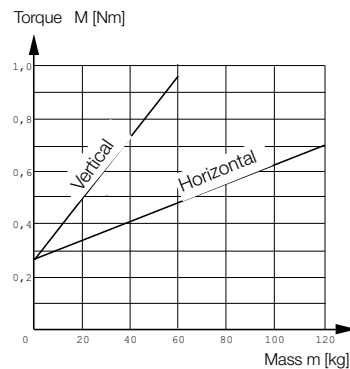

**Size OSP-E32SB, Pitch 10 mm
Acceleration 4 m/s²**

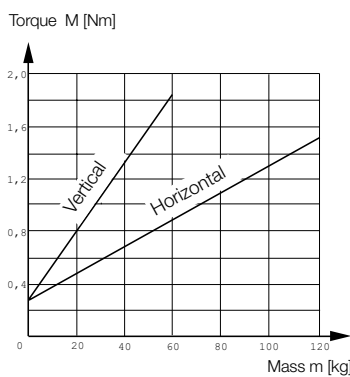

**Size OSP-E50SB, Pitch 5 mm
Acceleration 2 m/s²**

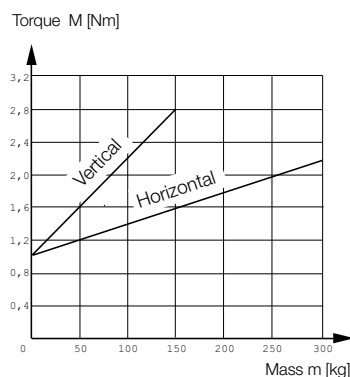

**Size OSP-E50SB, Pitch 10 mm
Acceleration 4 m/s²**

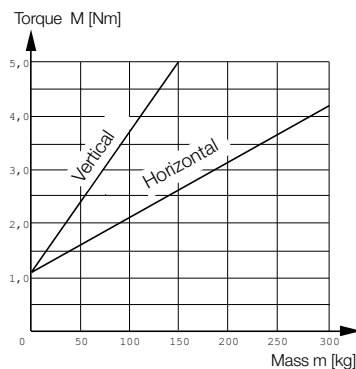

**Size OSP-E50SB, Pitch 25 mm
Acceleration 10 m/s²**

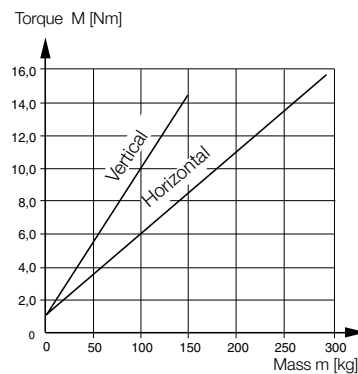

Parker Hannifin Corporation
Pneumatic Division - Europe

P-A4P017GB

OSP-E

OSP-E..SB
Ball Screw Actuator with Internal Plain Bearing Guide – Basic Unit

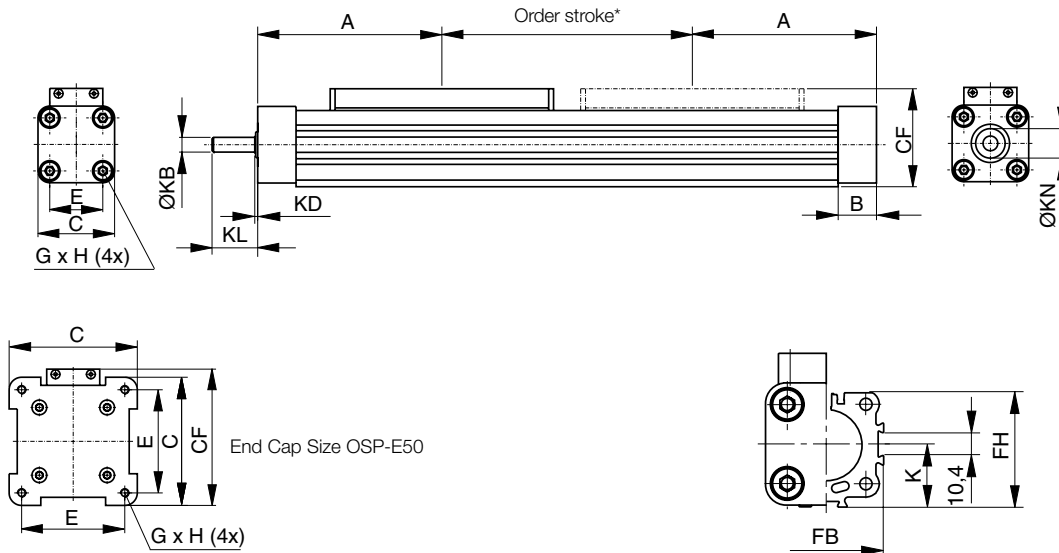

Plain Shaft with Keyway (Option)

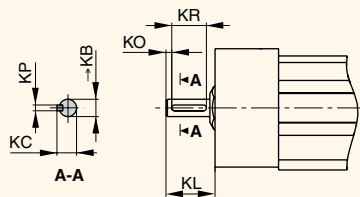

Series	ØKB _{h7}	KC	KL		KO	KPP ⁹	KR
			Opt. 3	Opt. 4			
OSP-E25SB	6	6.8	17	24	2	2	12
OSP-E32SB	10	11.2	31	41	5	3	16
OSP-E50SB	15	17.0	43	58	6	5	28

Option 3: Keyway
Option 4: Keyway long version

* **Note:** The mechanical end position must not be used as a mechanical end stop. Allow an additional safety clearance at both ends equivalent to the linear movement of one revolution of the drive shaft, but at least 25 mm. Order stroke = required travel + 2 x safety distance. The use of an AC motor with frequency converter normally requires a larger safety clearance than that required for servo systems. For further information, please contact your local Parker representative.

Option – Tandem

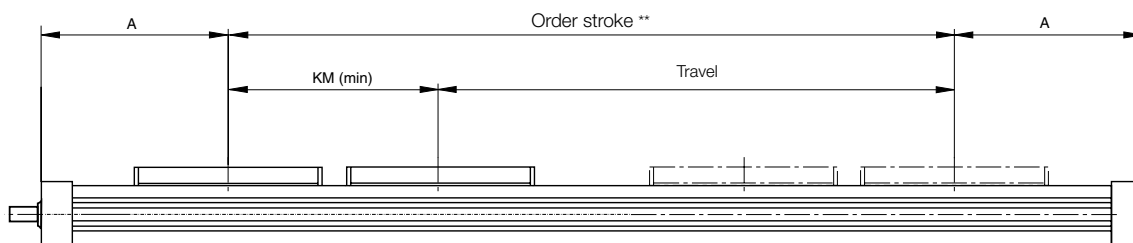

** Order stroke = required travel + KM min + 2 x safety distance



P-A4P017GB

OSP-E

Standard Carrier

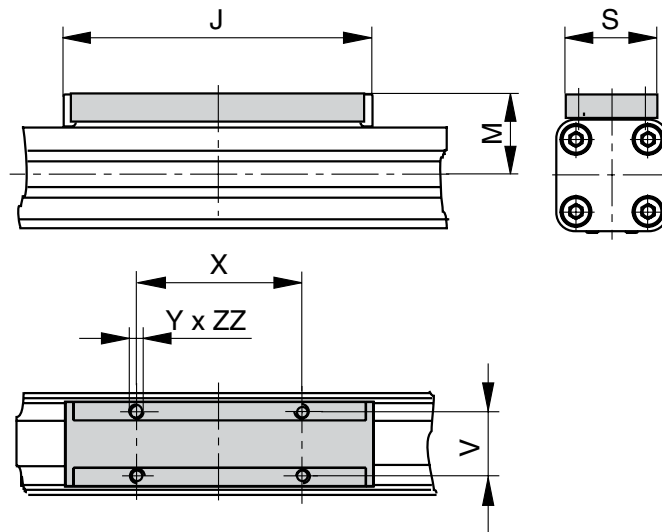

Dimension table [mm]

Series	A	B	C	E	G x H	J	K	M	S	V	X	Y	CF	FB	FH	KB	KD	KL	KM _{min}	KN	ZZ
OSP-E25SB	100	22.0	41	27	M5 x 10	117	21.5	31	33	25	65	M5	52.5	40	39.5	6 _{h7}	2	17	120	13	8
OSP-E32SB	125	25.5	52	36	M6 x 12	152	28.5	38	36	27	90	M6	66.5	52	51.7	10 _{h7}	2	31	165	20	10
OSP-E50SB	175	33.0	87	70	M6 x 12	200	43.0	49	36	27	110	M6	92.5	76	77.0	15 _{h7}	3	43	235	28	10

OSP-E

Order Instructions	OSPE25 - 1 0 3 0 0 - 00000 - 0 0 0 0 0 0
---------------------------	--

Size of Actuator	
25	Size 25
32	Size 32
50	Size 50

Type of Actuator	
1	Ball Screw Actuator with Internal Plain Bearing Guide

Carriage	
0	Standard
1*	Tandem
3*	Clean Room
4*	Position Measurement System SFI-plus (see page 171 ff)

Pitch	
3	5 mm (size 25, 32 and 50)
4	10 mm (size 32 and 50)
5	25 mm (size 50)

Gear Mounting *				
Size		25	32	50
0	without	x	x	x
1	LP050 i = 5	x	x	
2	LP050 i = 10	x	x	
3	LP070 i = 3		x	x
4	LP070 i = 5		x	x
5	LP070 i = 10		x	x

Order stroke	
5 digits input in mm	

Drive Shaft	
0 -	Plain Shaft
3 -*	Keyway
4 -*	Long with Keyway

Mounting Kit for Motor and Gear *				
Size		25	32	50
A0	SY563T	x ¹	x ¹	
A1	SY873T	x ¹	x ¹	x ¹
A2	SMx60 xx xxx 8 11 ...	x ¹	x ¹	
A3	SMx82 xx xx 8 14 ...		x ¹	x ¹
A7	PS60		x ¹	x ¹
C0	LP050 / PV40-TA	x ¹	x ¹	
C1	LP070 / PV60-TA		x ¹	x ¹

x¹: If a mounting kit is selected the **drive shaft** is a plain shaft

Info: Motor and gear mounting dimensions see page 191

P-A4P017GB

OSP-E

Guide Position	
0	Standard

External Guide / Carriage Mounting see page 155 ff	
0	without
2	SL Slideline
6	PL Proline
D	HD Heavy duty
E	PS Powerslide 25/25
F	PS Powerslide 25/35, 32/35
G	PS Powerslide 25/44, 32/44
H	PS Powerslide 50/60
I	PS Powerslide 50/76
M	Inversion
R	Compensation
S	Compensation Low Back Lash

Niro	
0	Standard
1*	Niro Screw

Accessories - please order separately	
Description	Page
Motor Mounting	137 ff
Multi-Axis System for Actuators	177 ff

Magnetic Sensors *		see page 165 ff
0	without	
1	1 pc. RST-K 2NO / 5 m Cable	
2	1 pc. RST-K 2NC / 5 m Cable	
3	2 pc. RST-K 2NC / 5 m Cable	
4	2 pc. RST-K 2NC, 1 pc. RST-K 2NO / 5 m Cable	
5	1 pc. RST-S 2NO / M8 plug	
6	1 pc. RST-S 2NC / M8 plug	
7	2 pc. RST-S 2NC / M8 plug	
8	2 pc. RST-S 2NC, 1 pc. RST-S 2NO / M8 plug	
A	1 pc. EST-S NPN / M8 plug	
B	2 pc. EST-S NPN / M8 plug	
C	3 pc. EST-S NPN / M8 plug	
D	1 pc. EST-S PNP / M8 plug	
E	2 pc. EST-S PNP / M8 plug	
F	3 pc. EST-S PNP / M8 plug	

Profile Mounting *		see pages 147 ff and 161 ff
0	without	
1	1 Pair Type 1	
2	1 Pair Type D1	
3	1 Pair Type MAE	
4	2 Pair Type 1	
5	2 Pair Type D1	
6	2 Pair Type MAE	
7	3 Pair Type 1	
8	3 Pair Type D1	
9	3 Pair Type MAE	
K	1 Pair Type E2	
L	1 Pair Type E3	
M	1 Pair Type E4	
N	2 Pair Type E2	
P	2 Pair Type E3	
Q	2 Pair Type E4	
R	3 Pair Type E2	
S	3 Pair Type E3	
T	3 Pair Type E4	

End Cap Mounting *		see page 141 ff and 161 ff
0	without	
1	1 pc. Type A1 (size 25 and 32) or C1 (size 50)	
2	1 pc. Type A2 (size 25 and 32) or C2 (size 50)	
3	1 pc. Type A3 (size 25 and 32) or C3 (size 50)	
4	1 pc. Type B1 (size 25 and 32) or C4 (size 50)	
5	1 pc. Type B4 (size 25 and 32)	

* Option

P-A4P017GB

OSP-E

P-A4P017GB

OSP-E

OSP-E..ST Trapezoidal Screw Actuator with Internal Plain Bearing Guide



Content

Description	Page
Overview	68
Technical Data	71
Dimensions	73
Order Instructions	76

P-A4P017GB
OSP-E

Trapezoidal Screw Actuator with Internal Plain Bearing Guide for Intermittent Applications

A completely new generation of actuators which can be integrated into any machine layout neatly and simply.

Advantages

- Accurate Path and Position Control
- High Force Output
- Self-Locking
- Excellent Slow Speed Characteristics
- Easy Installation
- Low Maintenance
- Ideal for Level Regulation, Lifting and Other Applications with Intermittent Operations

Features

- Integrated Drive and Guidance System
- Complete Motor and Control Packages
- Diverse Range of Accessories and Mountings
- Special Options Available

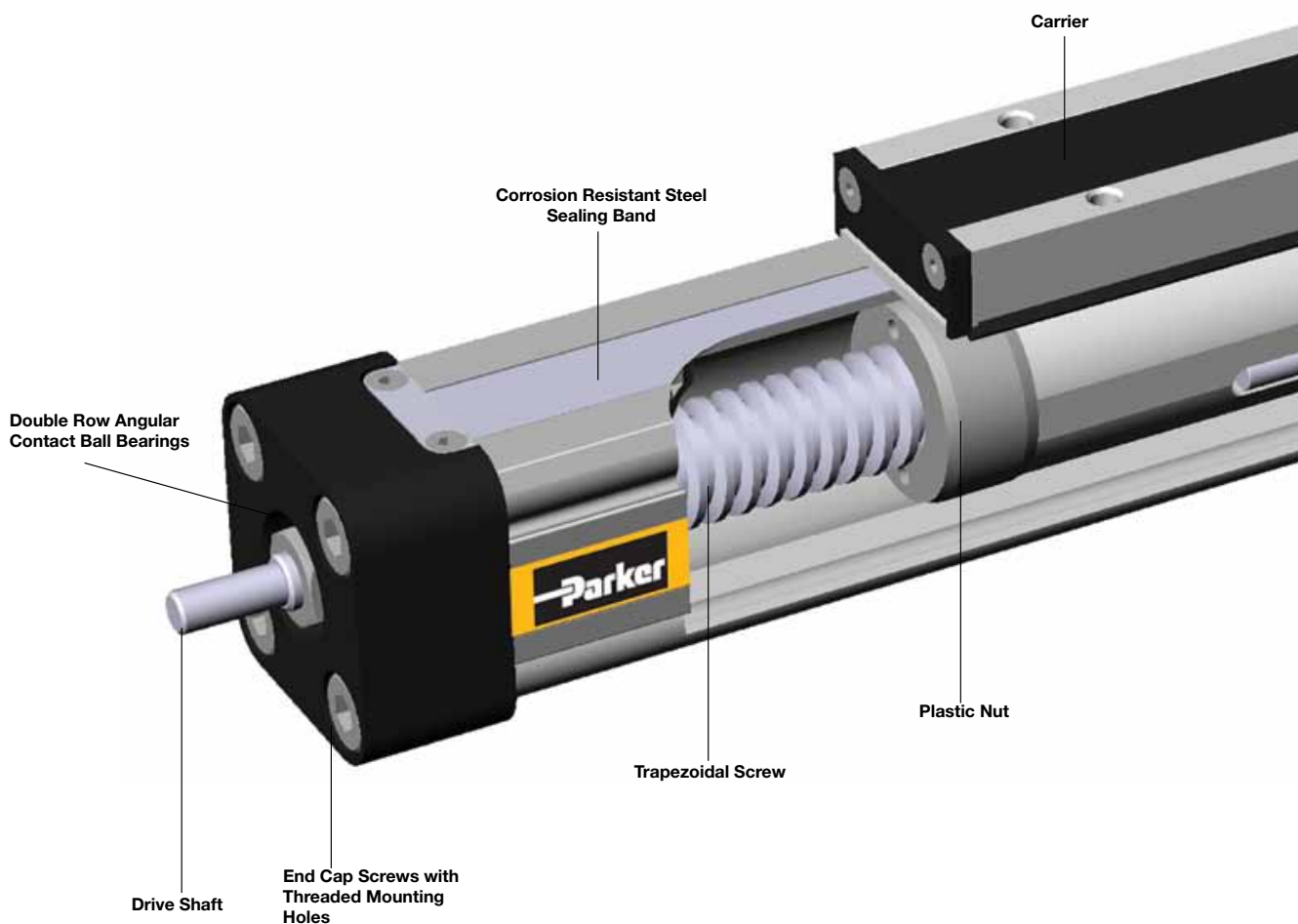

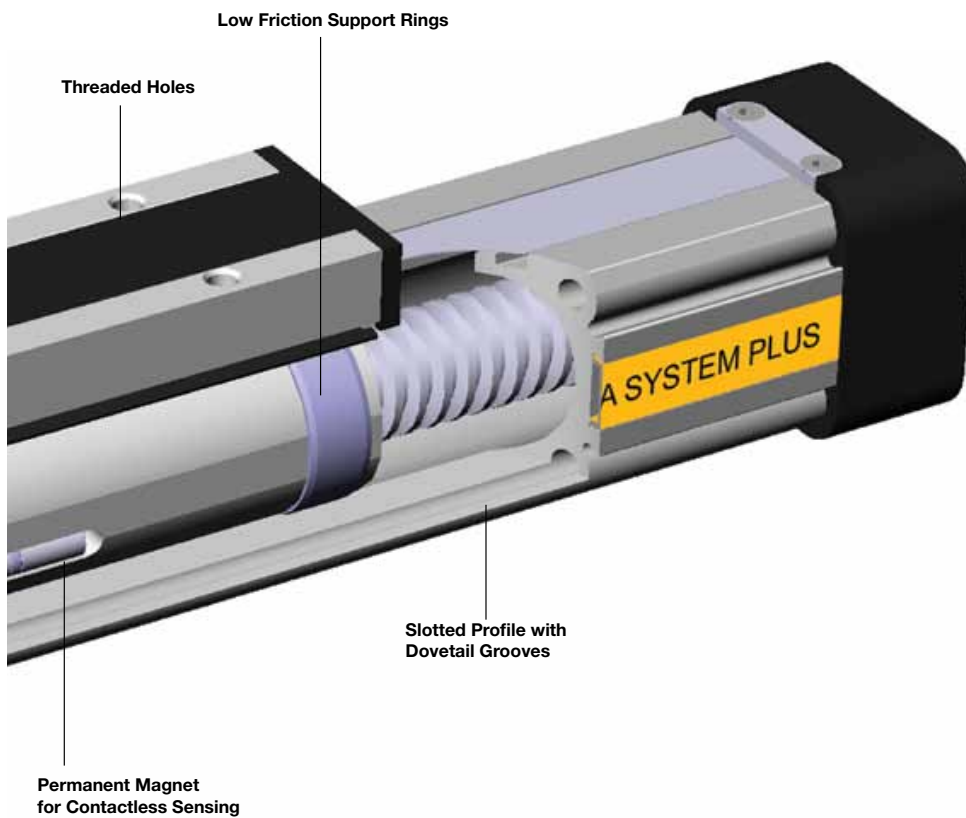

The dovetailed mounting rails of the new actuator expand its function into that of a universal system carrier. Modular system components are simply clamped on.

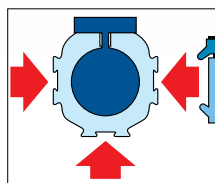

SLIDELINE
 Combination with linear guides provides for heavier loads.



POWERSLIDE
 Roller bearing precision guidance for smooth travel and high dynamic or static loads.



PROLINE
 The compact aluminium roller guide for high loads and velocities.



Heavy Duty guide
 HD linear guides for heavy duty applications

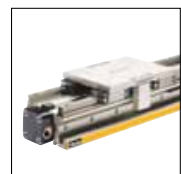

SFI-plus
 displacement measuring system



OSP-E..ST Trapezoidal Screw Actuator with Internal Plain Bearing Guide

Standard Versions
OSP-E..ST

Standard carrier with internal guidance and integrated magnet set for contactless position sensing. Dovetail profile for mounting of accessories and the actuator itself.

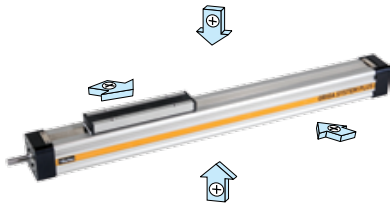

Accessories
Motor Mountings

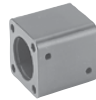

Inversion Mounting

The inversion mounting, mounted on the carrier, transfers the driving force to the opposite side, e.g. for dirty environments.

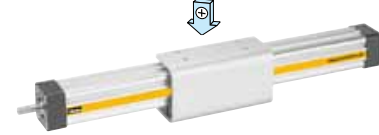

End Cap Mounting
For end-mounting of the actuator



Magnetic Sensors Series RST and EST
For contactless position sensing of end stop and intermediate carrier positions.



Profile Mounting
For supporting long actuators or mounting the actuator on the dovetail grooves.

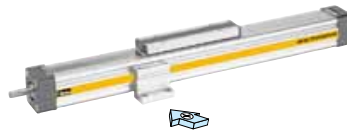

Measuring System - SFI PLUS
Incremental measuring system with practically relevant resolution.



Clevis Mounting
Carrier with tolerance and parallelism compensation to drive external linear guides.

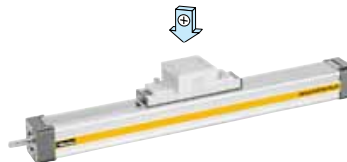

P-A4P017GB

OSP-E OSP-E..ST Trapezoidal Screw Actuator with Internal Plain Bearing Guide Size 25, 32, 50

Standard Version

- Standard Carrier with Internal Plain Bearing Guide
- Dovetail Profile for Mounting of Accessories and the Actuator itself
- Pitch of Trapezoidal Spindle:

Type OSP-E25ST: 4 mm

Type OSP-E32ST: 4 mm

Type OSP-E50ST: 6 mm

Options

- Displacement Measuring System SFI-plus
- Keyway



Characteristics

	Symbol	Unit	Description
General Features			
Series			OSP-E..ST
Name			Trapezoidal Screw Actuator with Internal Plain Bearing Guide
Mounting			see drawings
Temperature Range	ϑ_{min}	°C	-20
	ϑ_{max}	°C	+70
Weight (mass)		kg	see table
Installation			in any position
Material	Slotted Profile		Extruded Anodized Aluminium
	Trapezoidal Screw		Cold Rolled Steel
	Drive Nut		Thermoplastic Polyester
	Guide Bearings		Low Friction Plastic
	Sealing Band		Hardened, corrosion resistant steel
	Screws, Nuts		Zinc Plated Steel
	Mountings		Zinc Plated Steel and Aluminium
Protection Class		IP	54

Weight (mass) and Inertia

Series	Weight (mass) [kg]			Inertia [$\times 10^{-6}$ kgm ²]		
	at stroke 0 m	add per metre stroke	moving mass	at stroke 0 m	add per metre	per kg mass
OSP-E25ST	0.9	2.8	0.2	6.0	30	0.4
OSP-E32ST	2.1	5.0	0.5	21.7	81	0.4
OSP-E50ST	5.1	10.6	1.3	152.0	400	0.9

Installation Instructions

Use the threaded holes in the free end cap and a profile mounting close to the motor end for mounting the actuator.

See if profile mountings are needed using the maximum permissible unsupported length graph on page 73. At least one end cap must be secured to prevent axial sliding when Profile Mounting is used. When the actuator is moving an externally guided load, the compensation must be used. The actuators can be fitted with the standard carrier mounting facing in any direction.

To prevent contamination such as fluid ingress, the drive should be fitted with its sealing band facing downwards.

The inversion mounting can be fitted to transfer the driving force to the opposite side.

Maintenance

All moving parts are long-term lubricated for a normal operational environment. Parker recommends a check and lubrication of the actuator, and if necessary a change of wear parts, after an operation time of 12 months or 300 km travel of distance. Please refer to the operating instructions supplied with the drive.

First service start-up

The maximum values specified in the technical data sheet for the different products must not be exceeded. Before taking the actuator machine into service, the user must ensure the adherence to the EC Machine Directive 2006/42/EG.



Sizing of Actuator

The following steps are recommended for selection :

1. Check that maximum values in the table T3 are not exceeded.
2. Check the maximum values in graph on page 74 ff are not exceeded.
3. When sizing and specifying the motor, the RMS-average torque must be calculated using the cycle time of the application.
4. Check that the maximum allowable unsupported length is not exceeded (see on page 73 ff).

Performance Overview

Characteristics	Unit	Description		
		OSP-E25ST	OSP-E32ST	OSP-E50ST
Size				
Pitch	[mm]	4	4	6
Max. Speed	[m/s]	0.1	0.1	0.15
Linear Motion per Revolution Drive Shaft	[mm]	4	4	6
Max. rpm. Drive Shaft	[min ⁻¹]	1,500	1,500	1,500
Max. Effective Action Force F _A Corresponding Torque on Drive Shaft	[N] [Nm]	600 1.35	1,300 3.2	2,500 8.8
No-load Torque	[Nm]	0.3	0.4	0.5
Max. Allowable Torque on Drive Shaft	[Nm]	1.55	4.0	9.4
Self-locking Force F _L ¹⁾	[N]	600	1,300	2,500
Repeatability	[mm]	±0.05	±0.05	±0.05
Max. Standard Stroke Length	[mm]	1,100	2,000	2,500*

1) Related to screw Type s Tr 16x4, Tr 20x4, TR 30x6 see page 71 ff – for inertia.

* For strokes longer than 2,000 mm in horizontal applications, please contact our customer support.

Forces, Loads and Moments

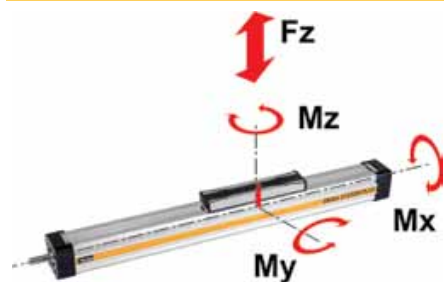

$$M = F \cdot l \text{ [Nm]}$$

$$M_x = M_{x \text{ static}} + M_{x \text{ dynamic}}$$

$$M_y = M_{y \text{ static}} + M_{y \text{ dynamic}}$$

$$M_z = M_{z \text{ static}} + M_{z \text{ dynamic}}$$

The distance l (lx, ly, lz) for calculation of the bending moments relates to the centre axis of the actuator.

Maximal Permissible Loads

T3

Size	Max. applied load [N]	Max. moments [Nm]		
		F _z , F _y	M _x	M _y
OSP-E25ST	500	2	24	7
OSP-E32ST	1000	6	65	12
OSP-E50ST	1500	13	155	26

Combined Loads

If the actuator is subjected to several forces, loads and moments at the same time, the maximum load is calculated with the equation shown here. The maximum permissible loads must not be exceeded.

Equation of Combined Loads

$$\frac{F_y}{F_y \text{ (max)}} + \frac{F_z}{F_z \text{ (max)}} + \frac{M_x}{M_x \text{ (max)}} + \frac{M_y}{M_y \text{ (max)}} + \frac{M_z}{M_z \text{ (max)}} \leq 1$$



Stroke Length

The stroke lengths of the actuators are available in multiples of 1 mm up to the following maximum stroke lengths.

OSP-E25ST: max. 1100 mm

OSP-E32ST: max. 2000 mm

OSP-E50ST: max. 2500 mm *

Other stroke lengths are available on request.

* For strokes longer than 2000 mm in horizontal applications, please contact our customer support

The end of stroke must not be used as a mechanical stop. Allow an additional safety clearance of minimum 25 mm at both ends. The use of an AC motor with frequency converter normally requires a larger safety clearance than that required for servo systems. For advise, please contact your local Parker technical support department.

Maximum Permissible Unsupported Length – Placing of Profile Mounting

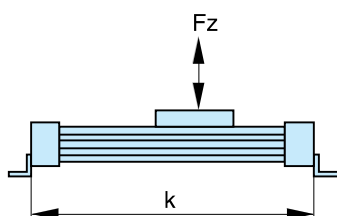

k = Maximum permissible distance between mountings/mid-section support for a given load F.

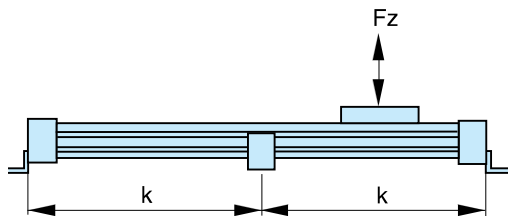

Mounting on the Drive Shaft

Do not expose the drive shaft to uncontrolled axial or radial forces when mounting coupling or pulley, a steadying block should be used.

Pulleys

Minimum allowable number of teeth (AT5) and diameter of pulley at maximum applied torque.

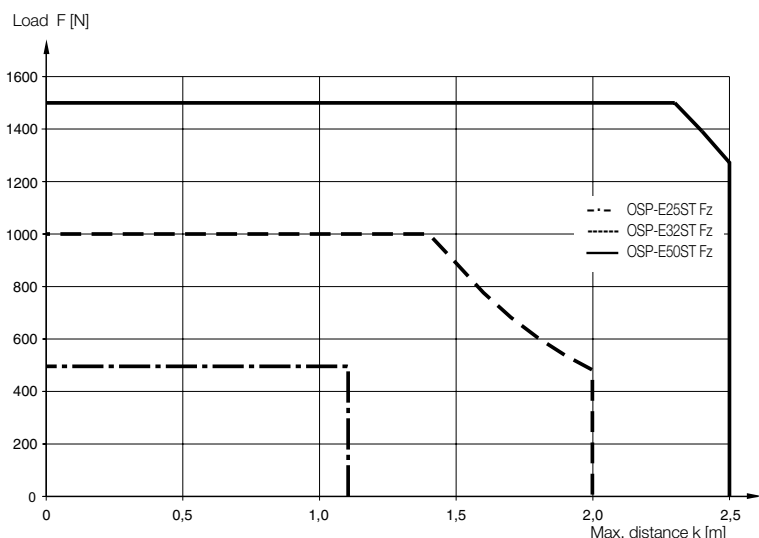
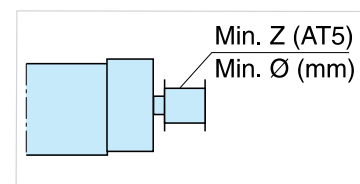

(Up to the curve in the above graph the deflection will be max. 0.2 % of distance k.)

Series	Min. Z	Min Ø
OSP-E25ST	24	38
OSP-E32ST	24	38
OSP-E50ST	36	57

P-A4P017GB

OSP-E

Maximum rpm / Stroke

At longer strokes the speed has to be reduced according to the adjacent graphs.

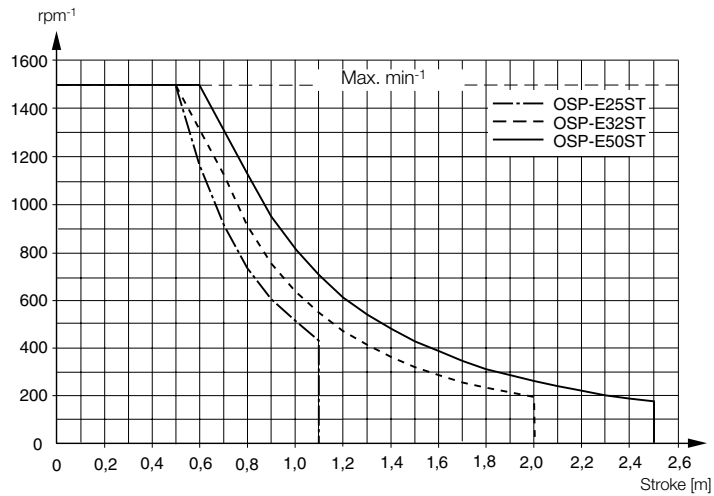

The maximum rpm shown in the graph, is 80% of the critical rpm.

Performance as a Function of the Action Force

The actuators are designed for a 10% intermittent usage.

The performance to be expected depends on the maximum required actions force of the application. An increase of the action force will lead to a reduced performance.

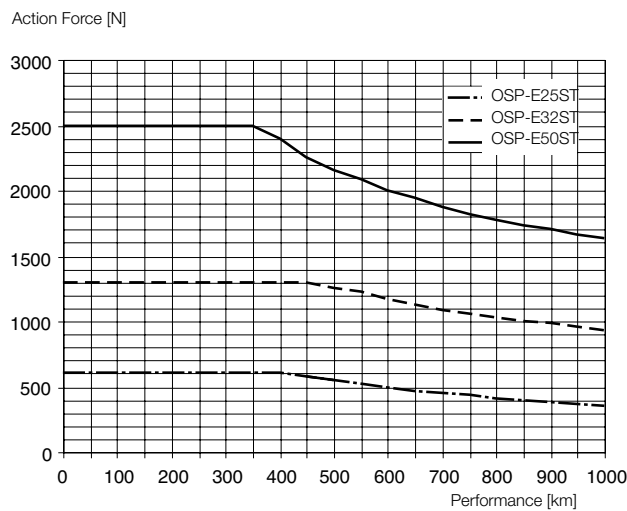

Note: Graph above is based upon 10% intermittent usage.

P-A4P017GB

OSP-E

OSP-E..ST

Trapezoidal Screw Actuator with Internal Plain Bearing Guide - Basic Unit

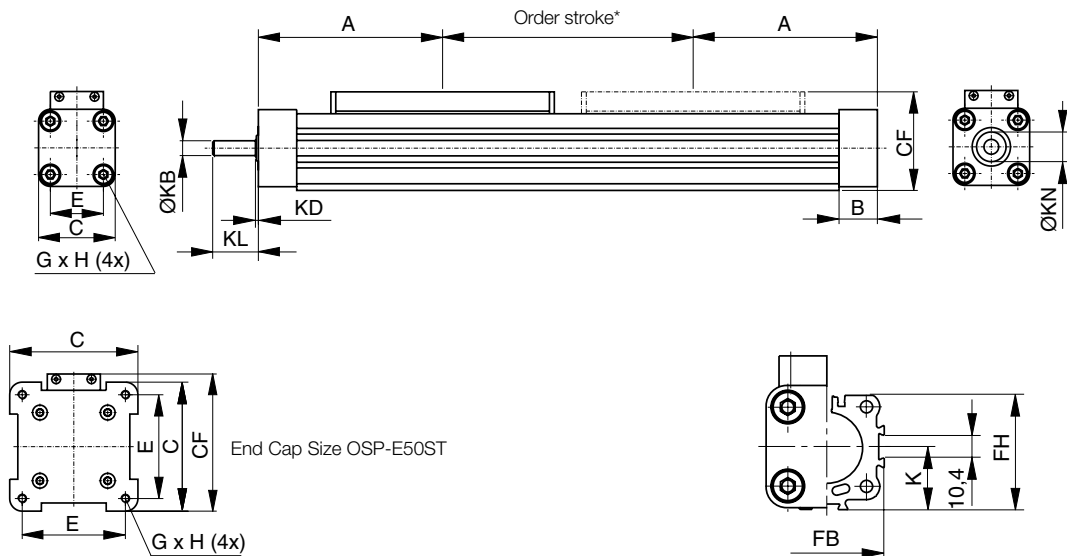

Plain Shaft with Keyway (Option)

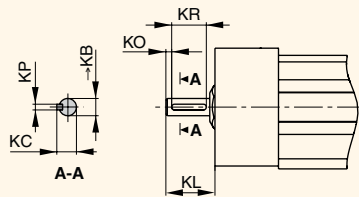

Series	ØKB _{h7}	KC	KL	KP		KO	KPP ⁹	KR
				Opt. 3	Opt. 4			
OSP-E20ST	6	6.8	17	24	2	2	12	
OSP-E25ST	10	11.2	31	41	5	3	16	
OSP-E50ST	15	17.0	43	58	6	5	28	

Option 3: Keyway
Option 4: Keyway long version

* **Note:** The mechanical end position must not be used as a mechanical end stop. Allow an additional safety clearance at both ends equivalent to the linear movement of one revolution of the drive shaft, but at least 25 mm. Order stroke = required travel + 2 x safety distance.

The use of an AC motor with frequency converter normally requires a larger safety clearance than that required for servo systems.

For further information, please contact your local Parker representative.

Standard Carrier

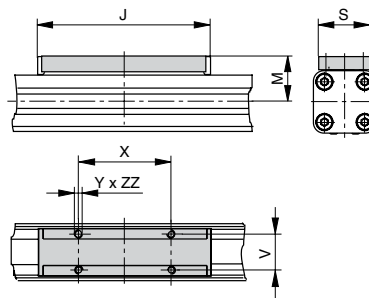

Dimension Table [mm]

Series	A	B	C	E	G x H	J	K	M	S	V	X	Y	CF	FB	FH	KB	KD	KL	KN	ZZ
OSP-E25ST	100	22.0	41	27	M5 x 10	117	21.5	31	33	25	65	M5	52.5	40	39.5	6 _{h7}	2	17	13	8
OSP-E32ST	125	25.5	52	36	M6 x 12	152	28.5	38	36	27	90	M6	66.5	52	51.7	10 _{h7}	2	31	20	10
OSP-E50ST	175	33.0	87	70	M6 x 12	200	43.0	49	36	27	110	M6	92.5	76	77.0	15 _{h7}	3	43	28	10



P-A4P017GB

OSP-E

Order Instructions	OSPE25	-	2	0	4	0	0-	00000	-	0	0	0	0	0	0
---------------------------	--------	---	---	---	---	---	----	-------	---	---	---	---	---	---	---

Size of Drive	
25	Size 25
32	Size 32
50	Size 50

Type of Drive	
2	Trapezoidal Screw Actuator with Internal Plain Bearing Guide

Carriage	
0	Standard
4	Position Measurement System SFI-plus * (see page 159 ff)

Pitch	
4	4 mm (for size 25 and 32)
6	6 mm (for size 50)

Gear Mounting *				
Size		25	32	50
0	without	x	x	x
1	LP050 i = 5	x	x	
2	LP050 i = 10	x	x	
3	LP070 i = 3		x	x
4	LP070 i = 5		x	x
5	LP070 i = 10		x	x

Info: For gears the mounting kit of the motor must be specified.
 LP050: A0, A1, A2
 LP070: A1, A2, A3

Order Stroke
5 digits input in mm

Drive Shaft	
0 -	Plain Shaft
3 -*	Keyway
4 -*	Long with Keyway

Mounting Kit for Motor and Gear *				
Size		25	32	50
A0	SY563T	x ¹	x ¹	
A1	SY873T	x ¹	x ¹	x ¹
A2	SMx60 xx xxx 8 11 ...	x ¹	x ¹	
A3	SMx82 xx xx 8 14 ...		x ¹	x ¹
A7	PS60		x ¹	x ¹
C0	LP050 / PV40-TA	x ¹	x ¹	
C1	LP070 / PV60-TA		x ¹	x ¹

x¹: If a mounting kit is selected the **drive shaft** is a plain shaft

Info: Motor and gear mounting dimensions see page 191

Guide Position	
0	Standard

External Guide / Carriage Mounting see pages 101 ff	
0	without
2	SL Slide Line
6	PL Proline
D	HD Heavy Duty
E	PS Power Slide 25/25
F	PS Power Slide 25/35, 32/35
G	PS Power Slide 25/44, 32/44
H	PS Power Slide 50/60
I	PS Power Slide 50/76
M	Inversion
R	Compensation
S	Compensation Low Back Lash

Niro	
0	Standard
1 *	Niro Screws

* Option

Accessories - please order separately	
Description	Page
Motor Mounting	137 ff
Multi-Axis System for Actuators	177 ff

* Option

Magnetic Sensors * see page 165 ff	
0	without
1	1 pc. RST-K 2NO / 5 m cable
2	1 pc. RST-K 2NC / 5 m cable
3	2 pc. RST-K 2NC / 5 m cable
4	2 pc. RST-K 2NC, 1 pc. RST-K 2NO / 5 m cable
5	1 pc. RST-S 2NO / M8 plug
6	1 pc. RST-S 2NC / M8 plug
7	2 pc. RST-S 2NC / M8 plug
8	2 pc. RST-S 2NC, 1 pc. RST-S 2NO / M8 plug
A	1 pc. EST-S NPN / M8 plug
B	2 pc. EST-S NPN / M8 plug
C	3 pc. EST-S NPN / M8 plug
D	1 pc. EST-S PNP / M8 plug
E	2 pc. EST-S PNP / M8 plug
F	3 pc. EST-S PNP / M8 plug

Profile Mounting * see page 147 and 161 ff	
0	without
1	1 Pair Type 1
2	1 Pair Type D1
3	1 Pair Type MAE
4	2 Pair Type 1
5	2 Pair Type D1
6	2 Pair Type MAE
7	3 Pair Type 1
8	3 Pair Type D1
9	3 Pair Type MAE
K	1 Pair Type E2
L	1 Pair Type E3
M	1 Pair Type E4
N	2 Pair Type E2
P	2 Pair Type E3
Q	2 Pair Type E4
R	3 Pair Type E2
S	3 Pair Type E3
T	3 Pair Type E4

End Cap Mounting *see page 129 and 143 ff	
0	without
1	1 pc. Type A1 (size 25 and 32) or C1 (size 50)
2	1 pc. Type A2 (size 25 and 32) or C2 (size 50)
3	1 pc. Type A3 (size 25 and 32) or C3 (size 50)
4	1 pc. Type B1 (size 25 and 32) or C4 (size 50)
5	1 pc. Type B4 (size 25 and 32)

P-A4P017GB

OSP-E

OSP-E..SBR Ball Screw Actuator with Internal Plain Bearing Guide and Piston Rod



Contents

Description	Page
Overview	80
Technical Data	83
Dimensions	85
Order Instructions	86

The right to introduce technical modifications is reserved

P-A4P017GB

OSP-E

Ball Screw Actuator with internal Plain Bearing Guide and Piston Rod for Accurate Piston Rod Applications

A completely new generation of actuators which can be integrated into any machine layout neatly and simply.

Advantages

- High Output Force
- Excellent Running Characteristics
- Accurate Path and Position Control
- High Levels of Repeatability

Features

- Extending Drive Rod
- Ball Screw Spindle
- Non-Rotating Drive Rod
- Continuous Duty Operation
- Large Range of Accessories

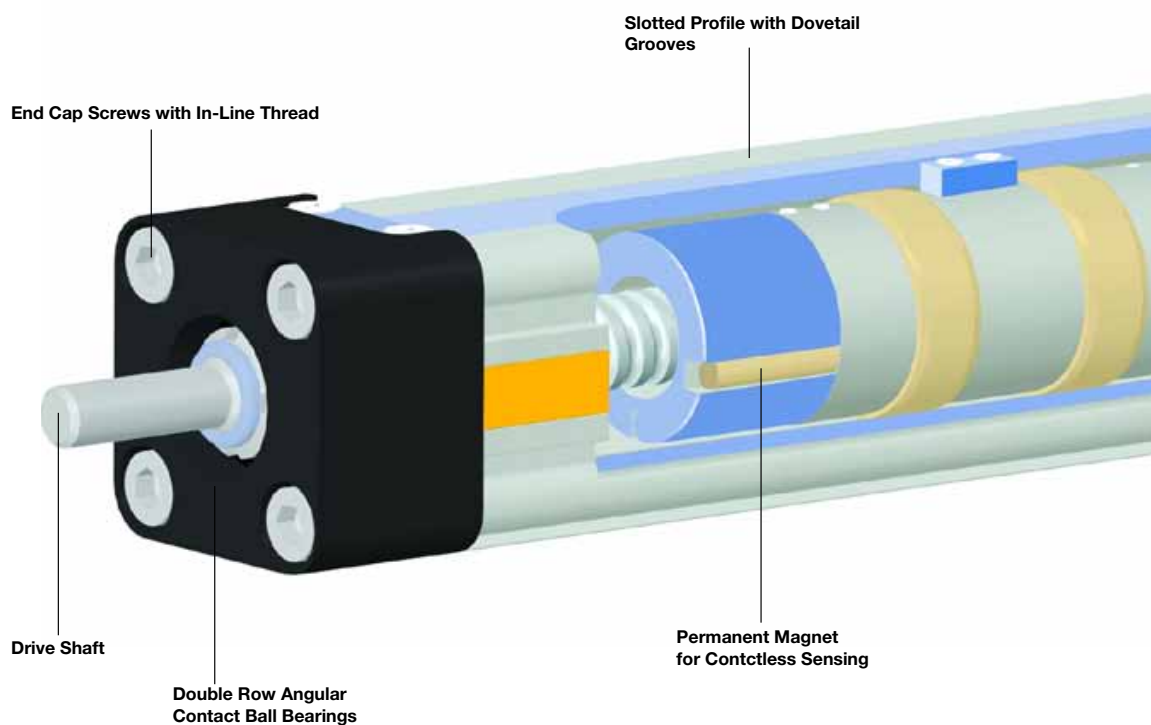

P-A4P017GB
OSP-E

The System Concept

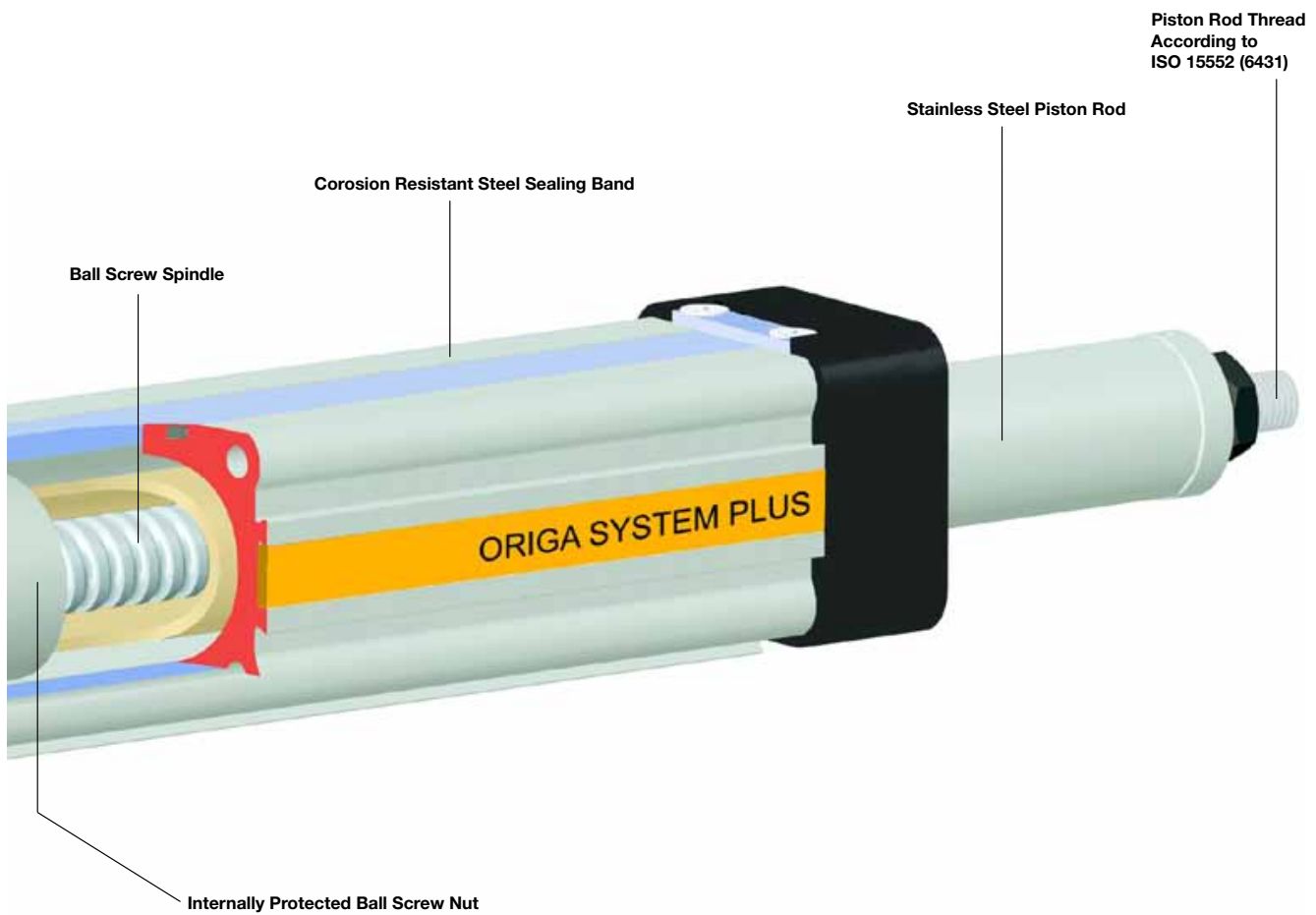

OSP-E..SBR

Ball Screw Actuator with Internal Plain Bearing Guide and Piston Rod

**Standard Versions
OSP-E..SBR**

Standard piston rod with internal guidance and integrated magnet set for contactless position sensing. Dovetail profile for mounting of accessories and the actuator itself.



Ball Screw Pitch

The ball screws spindles are available in various pitches:
 OSP-E25SBR: 5 mm
 OSP-E32SBR: 5, 10 mm
 OSP-E50SBR: 5, 10, 25 mm

Accessories

Motor Mountings



End Cap Mounting

For end-mounting the actuator on the extending rod side.



Flange Mounting C

For end-mounting the actuator on the extending rod side.



Profile Mounting

For mounting the actuator on the dovetail grooves and on the motor end.



Trunning Mounting EN

in combination with pivot mounting EL.
 – steplessly adjustable in axial direction.



Compensation

Piston Rod eye



Piston rod Clevis



Piston Rod Compensating Coupling

For compensating of radial and angular misalignments



**Magnetic Sensors
Series RST and EST**

For contactless position sensing of end stop and intermediate carrier positions.



P-A4P017GB

OSP-E OSP-E..SBR Ball Screw Actuator with Internal Plain Bearing Guide and Piston Rod - Size 25, 32, 50

Standard Version:

- Standard Piston Rod with Internal Plain Bearing Guide
- Pitches of Ball Screw Spindle:
Type OSP-E25SBR: 5 mm
Type OSP-E32SBR: 5, 10 mm
Type OSP-E50SBR: 5, 10, 25 mm

Option:

- Keyway Version



Characteristics

	Unit	Symbol	Description
General Features			
Series			OSP-E..SBR
Name			Ball Screw Actuator with Internal Plain Bearing Guide and Piston Rod
Mounting			see drawings
Temperature Range		°C	-20
		°C	+80
Weight (mass)		kg	see table
Installation			in any position
Material	Slotted Profile		Al Anodized
	Ball Screw		Steel
	Ball Nut		Steel
	Piston Rod		Stainless Steel
	Guide Bearings		Low Friction Plastic
	Sealing Band		Hardened, Corrosion Resistant Steel
	Screws, Nuts		Zinc Plated Steel
	Mountings		Zinc Plated Steel and Aluminium
	Protection Class		IP

Weight (mass) and Inertia

Series	Weight (mass) [kg]		Moving Mass[kg]		Inertia [x 10 ⁻⁶ kgm ²]	
	at stroke 0 m	add per metre stroke	at stroke 0 m	add per metre stroke	at stroke 0 m	add per metre stroke
OSP-E25ST	0.7	3.0	0.2	0.9	1.2	11.3
OSP-E32ST	1.7	5.6	0.6	1.8	5.9	32.0
OSP-E50ST	4.5	10.8	1.1	2.6	50.0	225.0

Installation Instructions

Use the threaded holes in the free end cap and a profile mounting close to the motor end for mounting the actuator. The piston rod is locked against rotations, but must not be used for radial loads M_x , that need to be guided externally. A compensation part e. g. piston rod eye (see order instructions page 86) is recommended.

Maintenance

All moving parts are long-term lubricated for a normal operational environment. Parker recommends a check and lubrication of the actuator, and if necessary a change of wear parts, after an operation time of 12 months or 3000 km travel of distance. Please refer to the operating instructions supplied with the actuator.

First service start-up

The maximum values specified in the technical data sheet for the different products must not be exceeded. Before taking the actuator as a machine into service, the user must ensure the adherence to the EC Machine Directive 2006/42/EG.

Performance Overview

Characteristics	Unit	Description					
		OSP-E25SBR		OSP-E32SBR		OSP-E50SBR	
Series							
Pitch	[mm]	5	5	10	5	10	25
Max. Speed	[m/s]	0.25	0.25	0.5	0.25	0.5	1.25
Linearer Motion per Revolution Drive Shaft	[mm]	5	5	10	5	10	25
Maximum rpm. Drive Shaft	[min ⁻¹]	3000	3000		3000		
Max. Effective Action Force F_A Corresponding Torque Drive Shaft	[N]	260	900	1200	1200	2.8	6.0
	[Nm]	0.45	1.1	1.8	1.3	2.8	6.0
No-load Torque	[Nm]	0.2	0.2	0.3	0.3	0.4	0.5
Max. Allowable Torque on Drive Shaft	[Nm]	0.6	1.5	2.8	4.2	7.5	20
Max. Allowable Acceleration	[m/s ²]	5	5		5		
Typical Repeatability	[mm]	±0.05	±0.05		±0.05		
Max. Standard Stroke	[mm]	500	500		500		

Sizing of Actuator

The following steps are recommended for selection :

1. Check that the maximum values in the adjacent chart and transverse force/stroke graph below are not exceeded.
2. Check the lifetime/travel distance in graph below.
3. When sizing and specifying the motor, the RMS-average torque must be calculated using the cycle time in application.

Transverse Force / Stroke

The permissible transverse force is reduced with increasing stroke length according to the adjacent graphs.

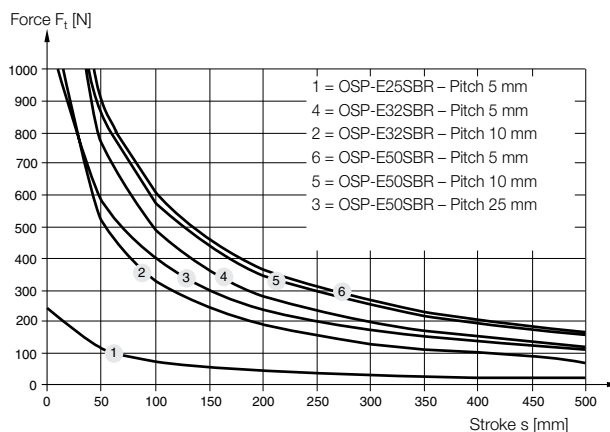
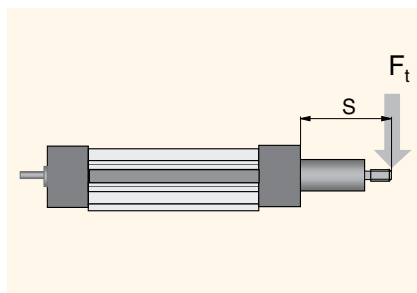

Maximum rpm / Stroke

At longer strokes the speed has to be reduced according to the adjacent graphs.

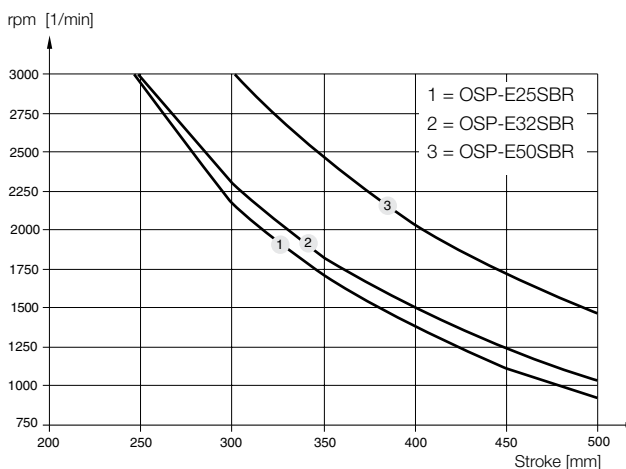

P-A4P017GB

OSP-E

Performance / Action Force

Performance as a Function of the Action Force

The performance to be expected depends on the maximum required actions force of the application.

An increase of the action force will lead to a reduced performance.

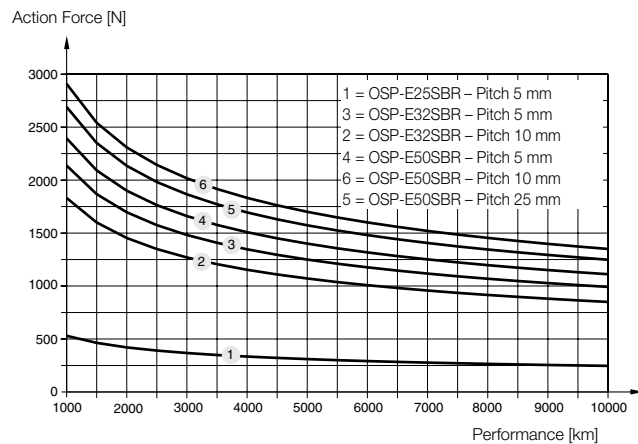

OSP-E..SBR

Ball Screw Actuator with Internal Plain Bearing Guide and Piston Rod - Basic Unit

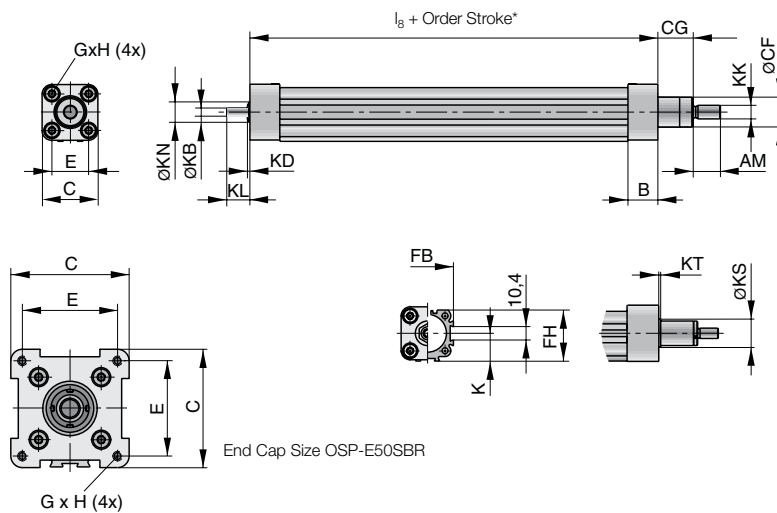

Plain Shaft with Keyway (Option)

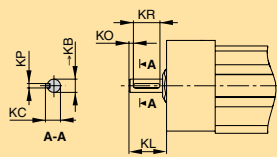

Series	ØKB _{h7}	KC	KL		KO	KP ^{P9}	KR
			Opt. 3	Opt. 4			
OSP-E25SBR	6	6.8	17	24	2	2	12
OSP-E32SBR	10	11.2	31	41	5	3	16
OSP-E50SBR	15	17.0	43	58	6	5	28

Option 3: Keyway Option 4: Keyway long Version

* **Note:** The mechanical end position must not be used as a mechanical end stop. Allow an additional safety clearance at both ends equivalent to the linear movement of one revolution of the drive shaft, but at least 25 mm. Order stroke = required travel + 2 x safety distance. The use of an AC motor with frequency converter normally requires a larger safety clearance than that required for servo systems. For further information, please contact your local Parker representative.

Dimension [mm]

Series	B	C	E	G x H	K	I _g	AM	ØCF	CG	FB	FH	ØKB	KD	KK	KL	ØKN	ØKS	KT
OSP-E25SBR	22.0	41	27	M5 x 10	21.5	110.0	20	22	26	40	39.5	6 _{h7}	2	M10 x 1.25	17	13	-	-
OSP-E32SBR	25.5	52	36	M6 x 12	28.5	175.5	20	28	26	52	51.7	10 _{h7}	2	M10 x 1.25	31	20	33	2
OSP-E50SBR	33.0	87	70	M6 x 12	43.0	206.0	32	38	37	76	77.0	15 _{h7}	3	M16 x 1.5	43	28	44	3



Parker Hannifin Corporation
Pneumatic Division - Europe

P-A4P017GB

OSP-E

Order Instructions	OSPE25	-	4	0	5	0	0	-	00000	-	0	0	0	0	0	0
--------------------	--------	---	---	---	---	---	---	---	-------	---	---	---	---	---	---	---

Size of Drive	
25	Size 25
32	Size 32
50	Size 50

Type of Drive	
4	Ball Screw Actuator with Internal Plain Bearing Guide And Piston Rod

Pitch	
5	5 mm (for size 25, 32 and 50)
7	10 mm (for size 32 and 50)
8	25 mm (for size 50)

Gear mounting *				
Size		25	32	50
0	without	x	x	x
1	LP050 i = 5	x	x	
2	LP050 i = 10	x	x	
3	LP070 i = 3		x	x
4	LP070 i = 5		x	x
5	LP070 i = 10		x	x

Info: For gears the mounting kit of the motor must be specified.
 LP050: A0, A1, A2
 LP070: A1, A2, A3

Order stroke
5 digits input in mm

Drive Shaft	
0 -	Plain Shaft
3 -*	Keyway
4 -*	Long with Keyway

Mounting Kit for Motor and Gear *				
Size		25	32	50
A0	SY563T	x ¹	x ¹	
A1	SY873T	x ¹	x ¹	x ¹
A2	SMx60 xx xxx 8 11 ...	x ¹	x ¹	
A3	SMx82 xx xx 8 14 ...		x ¹	x ¹
A7	PS60		x ¹	x ¹
C0	LP050 / PV40-TA	x ¹	x ¹	
C1	LP070 / PV60-TA		x ¹	x ¹

x¹: If a mounting kit is selected the **drive shaft** is a plain shaft

Info: Motor and gear mounting dimensions see page 191

P-A4P017GB

OSP-E

Piston Rod Mounting * see page 155 ff	
0	without
T	Piston Rod Eye
U	Piston Rod Clevis
V	Piston Rod Compensating Coupling

Niro	
0	Standard
1*	Niro Screws

Magnetic Sensors * see page 165 ff	
0	without
1	1 pc. RST-K 2NO / 5 m Cable
2	1 pc. RST-K 2NC / 5 m Cable
3	2 pc. RST-K 2NC / 5 m Cable
4	2 pc. RST-K 2NC, 1 pc. RST-K 2NO / 5 m Cable
5	1 pc. RST-S 2NO / M8 plug
6	1 pc. RST-S 2NC / M8 plug
7	2 pc. RST-S 2NC / M8 plug
8	2 pc. RST-S 2NC, 1 pc. RST-S 2NO / M8 plug
A	1 pc. EST-S NPN / M8 plug
B	2 pc. EST-S NPN / M8 plug
C	3 pc. EST-S NPN / M8 plug
D	1 pc. EST-S PNP / M8 plug
E	2 pc. EST-S PNP / M8 plug
F	3 pc. EST-S PNP / M8 plug

Profile mounting * see page 141 ff	
0	without
1	1 Pair Type 1
2	1 Pair Type D1
3	1 Pair Type MAE
4	2 Pair Type 1
5	2 Pair Type D1
6	2 Pair Type MAE
7	3 Pair Type 1
8	3 Pair Type D1
9	3 Pair Type MAE
see page 154	
K	1 Pair Trunnion Mounting EN
L	1 Pair Trunnion EN and Pivot Mounting EL

End cap mounting * see pages 141 ff	
0	without
1	1 pc. Type A1SR (size 25 and 32) or C1SR (size 50)
2	1 pc. Type C-E

Accessories - please order separately	
Description	Page
Motor Mounting	137 ff
Multi-Axis System for Actuators	177 ff

* Option

P-A4P017GB

OSP-E

Trapezoidal Screw Actuator with Internal Plain Bearing Guide and Piston Rod



Content

Description	Page
Overview	90
Technical Data	93
Dimensions	95
Order Instructions	96

The right to introduce technical modifications is reserved

P-A4P017GB

OSP-E

Trapezoidal Screw Actuator with Internal Plain Bearing Guide and Piston Rod for Intermittent Applications

A completely new generation of actuators which can be integrated into any machine layout neatly and simply.

Advantages

- Accurate Path and Position Control
- High Force Output
- Self-Locking
- Excellent Slow Speed Characteristics
- Easy Installation
- Low Maintenance
- Ideal for Level Regulation, Lifting and Other Applications with Intermittent Operations

Features

- Piston Rod-End Dimensions Conforming to ISO Pneumatic Standards
- Complete Motor and Control Packages
- Diverse Range of Accessories and Mountings
- Special Options Available

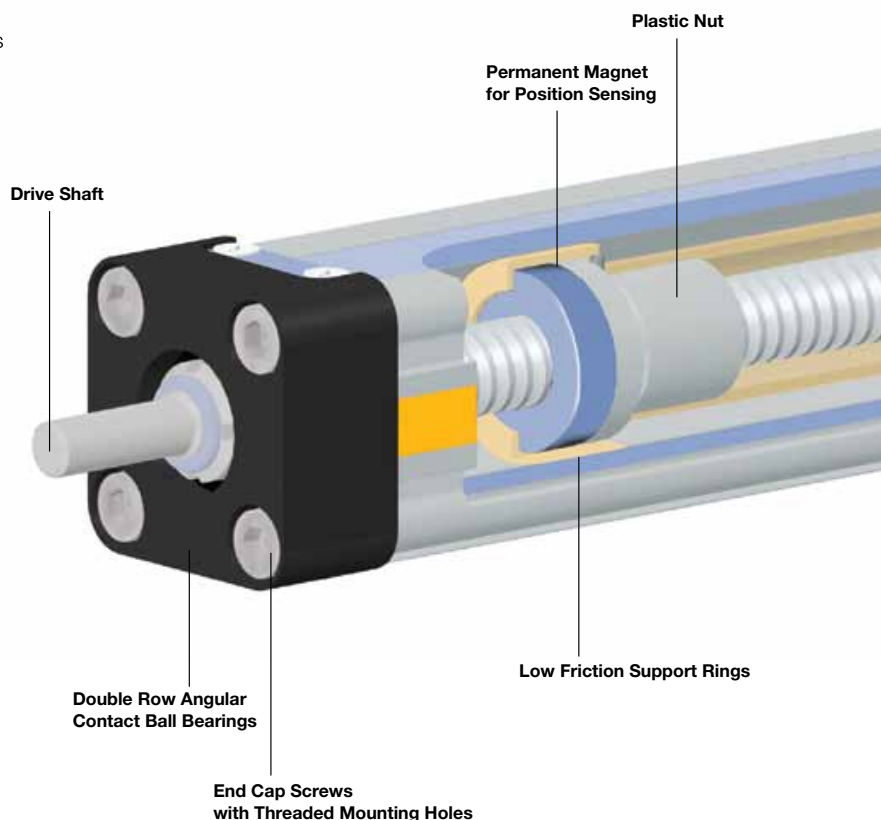

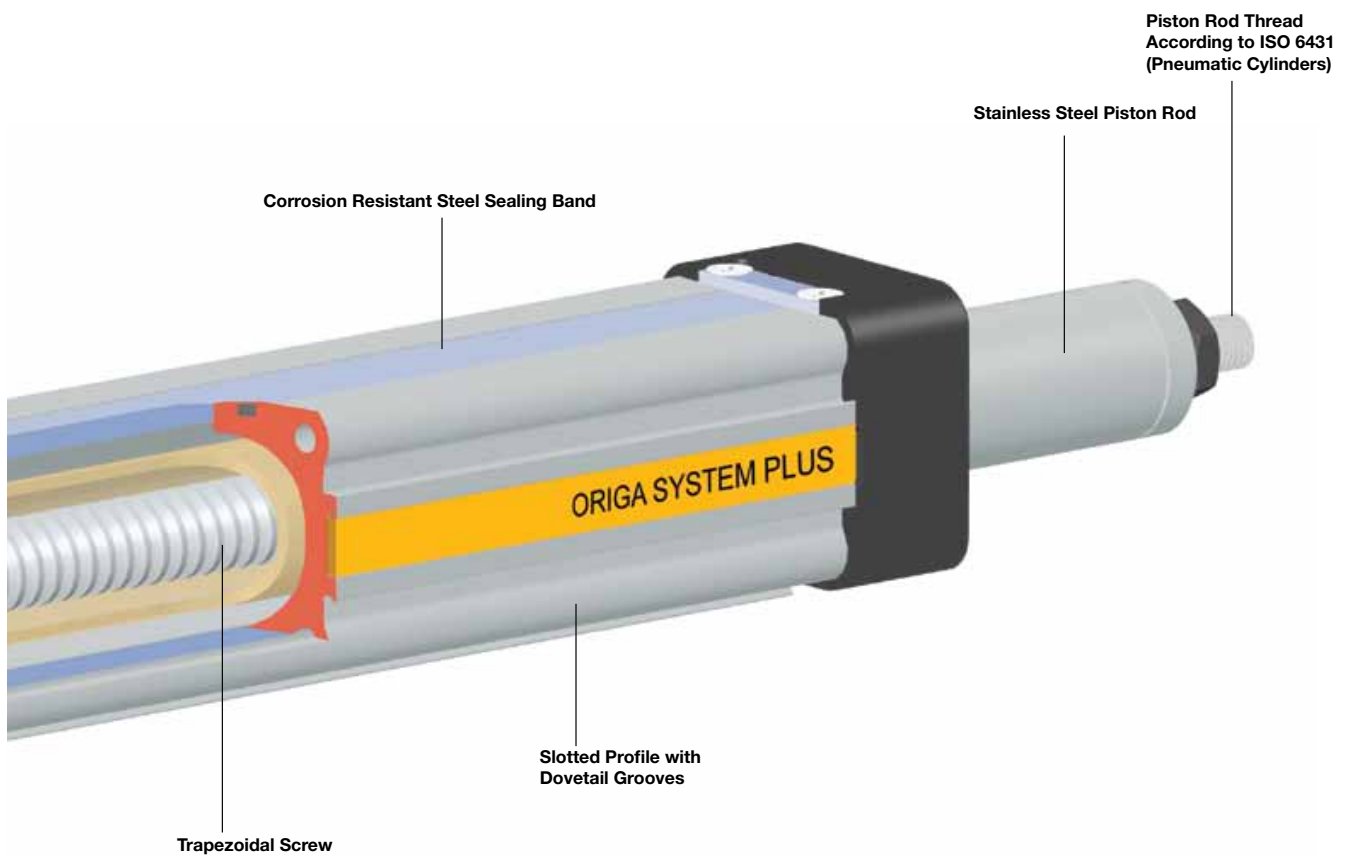

OSP-E..STR
Trapezoidal Screw Actuator with Internal Plain Bearing Guide and Piston Rod

Standard Versions

OSP-E..STR

Standard piston rod with internal guidance and integrated magnet set for contactless position sensing. Dovetail profile for mounting of accessories and the actuator itself.



Accessories

Motor Mountings



End Cap Mounting

For end-mounting the actuator on the extending rod side.

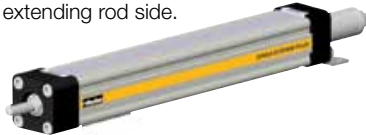

Compensation Piston Rod Eye



Flange Mounting C

For end-mounting the actuator on the extending rod side.



Piston Rod Clevis



Profile Mounting

For mounting the actuator on the dovetail grooves and on the motor end.



Piston Rod Compensating Coupling

For compensating of radial and angular misalignments



Turning Mounting EN

in combination with pivot mounting EL.
 – steplessly adjustable in axial direction.



Magnetic Sensors Series RST and EST

For contactless position sensing of end stop and intermediate carrier positions.



P-A4P017GB

OSP-E

OSP-E..STR Trapezoidal Screw Actuator with Internal Plain Bearing Guide and Piston Rod - Size 25, 32, 50

Standard Version

- Dovetail Profile for Mounting of Accessoires and the Acuator Itself

- Pitch of Trapezoidal Spindle

Type OSP-E25STR: 3 mm

Type OSP-E32STR: 4 mm

Type OSP-E50STR: 5 mm



Characteristics

	Symbol	Unit	Description
General Features			
Series			OSP-E..STR
Name			Trapezoidal Actuator with Internal Plain Bearing Guide and Piston Rod
Mounting			see drawings
Temperature Range	ϑ_{min}	°C	-20
	ϑ_{max}	°C	+70
Weight (mass)		kg	see table
Installation			in any position
Material	Slotted Profile		Extruded Anodized Aluminium
	Trapezoidal Screw		Cold Rolled Steel
	Drive Nut		Thermoplastic Polyester
	Piston Rod		Stainless Steel
	Sealing Band		Hardened, Corrosion Resistant Steel
	Guide Bearings		Low Friction Plastic
	Screws, Nuts		Zinc Plated Steel
	Mountings		Zinc Plated Steel and Aluminium
Protection Class		IP	54

Weight (Masse) and Inertia

Series	Weight (mass) [kg]		Moving Mass[kg]		Inertia [$\times 10^{-6}$ kgm ²]	
	At stroke 0 m	Add per metre stroke	At stroke 0 m	Add per metre stroke	At stroke 0 m	Add per metre stroke
OSP-E25STR	0.4	2.9	0.1	0.7	1.1	10.3
OSP-E32STR	0.9	5.4	0.2	1.2	3.9	29.6
OSP-E50STR	2.4	10.6	0.8	1.6	24.6	150

Installation Instructions

Use the threaded holes in the free end cap and a profile mounting close to the motor end for mounting the actuator.

The piston rod is not locked against rotation and needs to be guided externally. A compensation part e. g. piston rod eye (see order instructions page 96) is recommended.

Maintenance

All moving parts are long-term lubricated for a normal operational environment. Parker Origa recommends a check and lubrication of the actuator, and if necessary a change of wear parts, after an operation time of 12 months or 300 km travel of distance. Please refer to the operating instructions supplied with the actuator.

First service start-up

The maximum values specified in the technical data sheet for the different products must not be exceeded. Before taking the actuator as a machine into service, the user must ensure the adherence to the EC Machine Directive 2006/42/EG.

Contactless position sensing

Please use the magnetic sensor mentioned below:

KL3096 (Type RS-K, normally closed, Reed-contact, with cable)

KL3098 (Type ES-S, Magnetic electronic, PNP-sensor with DIN-plug)

P-A4P017GB

OSP-E

Performance Overview

Characteristics	Unit	Description		
Size		OSP-E25STR	OSP-E32STR	OSP-E50STR
Pitch	[mm]	3	4	5
Max. Speed	[m/s]	0.075	0.1	0.125
Linear Motion per Revolution, Drive Shaft	[mm]	3	4	5
Max. rpm, Drive Shaft	[min ⁻¹]	1500 ²⁾	1500	1500
Max. Effective Force Action F_A	[N]	800	1600	3300
Corresponding Torque on Drive Shaft	[Nm]	1.35	3.4	9.25
No-loads Torque	[Nm]	0.3	0.4	0.5
Max. Allowable Torque on Drive Shaft	[Nm]	1.7	4.4	12
Self-locking Force F_L ¹⁾	[N]	800	1600	3300
Typical Repeatability	[mm]	±0.05	±0.05	±0.05
Max. Standard Stroke Length	[mm]	500	500	500

- ¹⁾ Related to screw Type s Tr 12x3, Tr 16x4, Tr 24x5 see page 93 – for inertia
²⁾ from 0.4 m stroke max. 1200 min⁻¹ permissible

Transverse Force / Stroke

The permissible transverse force is reduced with increasing stroke length according to the adjacent graphs.

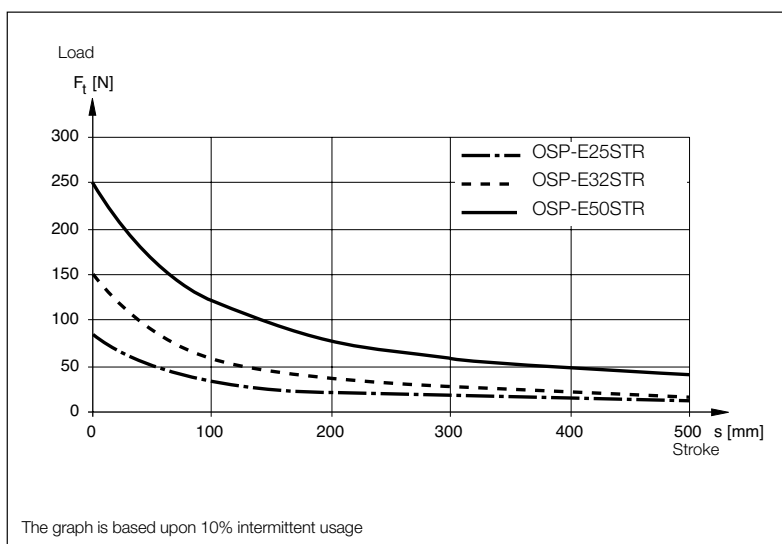
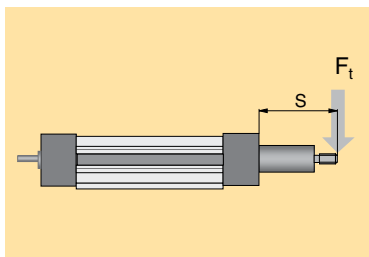

Performance / Action Force

The Actuators are designed for a 10% intermittent usage.

The performance to be expected depends on the maximum required actions force of the application. An increase of the action force will lead to a reduced performance.

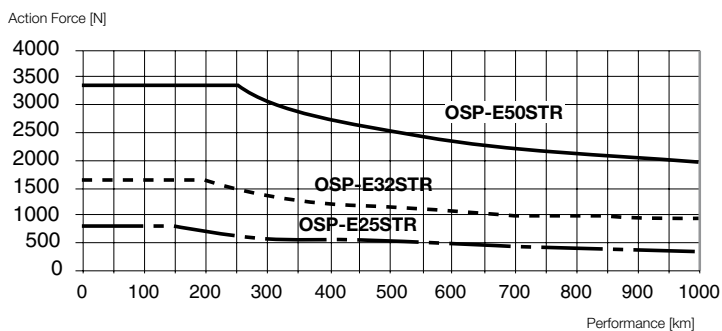

P-A4P017GB

OSP-E

OSP-E..STR

OSP-E..STR
Trapezoidal Screw Actuator with Internal Plain Bearing Guide and Piston Rod - Basic Unit

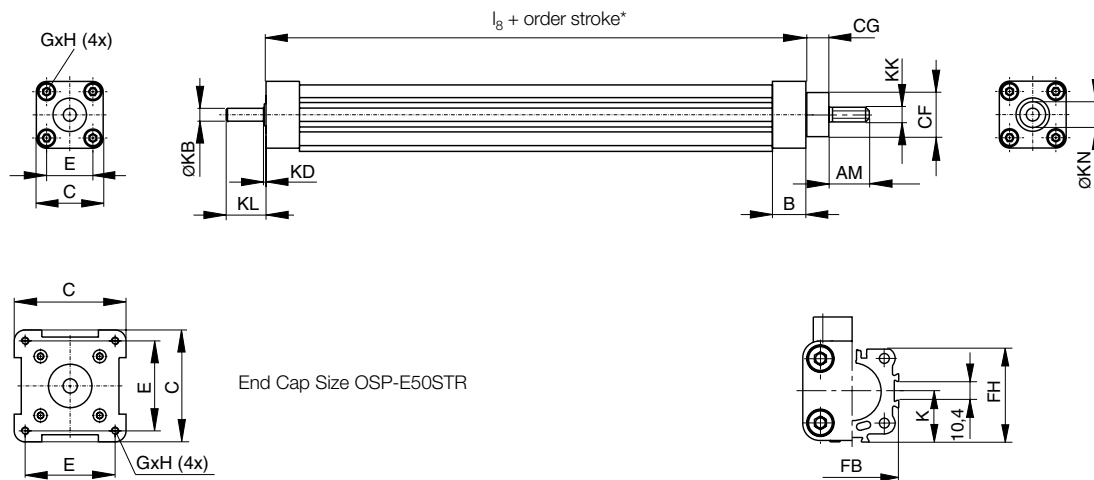

End Cap Size OSP-E50STR

Plain Shaft with Keyway (Option)

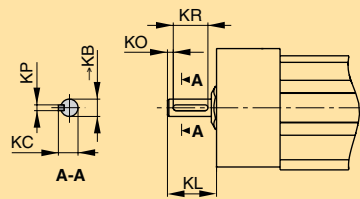

Series	∅KB _{h7}	KC	KL		KO	KP ^{P9}	KR
			Opt. 3	Opt. 4			
OSP-E25SBR	6	6.8	17	24	2	2	12
OSP-E32SBR	10	11.2	31	41	5	3	16
OSP-E50SBR	15	17.0	43	58	6	5	28

Option 3: Keyway Option 4: Keyway long version

* **Note:** The mechanical end position must not be used as a mechanical end stop. Allow an additional safety clearance at both ends equivalent to the linear movement of one revolution of the drive shaft, but at least 25 mm. Order stroke = required travel + 2 x safety distance. The use of an AC motor with frequency converter normally requires a larger safety clearance than that required for servo systems. For further information, please contact your local Parker representative.

Dimension [mm]

Series	B	C	E	G x H	K	l ₈	AM	CF	CG	FB	FH	KB	KD	KK	KL	KN
OSP-E25STR	22.0	41	27	M5 x 10	21.5	83.0	20	22	26	40	39.5	6 _{h7}	2	M10 x 1.25	17	13
OSP-E32STR	25.5	52	36	M6 x 12	28.5	94.0	20	28	26	52	51.7	10 _{h7}	2	M10 x 1.25	31	20
OSP-E50STR	33.0	87	70	M6 x 12	43.0	120.0	32	38	37	76	77.0	15 _{h7}	3	M16 x 1.5	43	28

P-A4P017GB

OSP-E

Order Instructions OSPE25 - 3 0 3 0 0 - 00000 - 0 0 0 0 0 0

Size of Drive	
25	Size 25
32	Size 32
50	Size 50

Type of Drive	
3	Trapezoidal Screw Actuator with Internal Plain Bearing Guide and Piston Rod

Pitch	
3	3 mm (for size 25)
4	4 mm (for size 32)
5	5 mm (for size 50)

Gear Mounting *				
Size		25	32	50
0	without	x	x	x
1	LP050 i = 5	x	x	
2	LP050 i = 10	x	x	
3	LP070 i = 3		x	x
4	LP070 i = 5		x	x
5	LP070 i = 10		x	x

Info: For gears the mounting kit of the motor must be specified.
 LP050: A0, A1, A2
 LP070: A1, A2, A3

Order Stroke	
5 digits input in mm	

Drive Shaft	
0 -	Plain Shaft
3 -*	Keyway
4 -*	Long with Keyway

Mounting Kit for Motor and Gear *				
Size		25	32	50
A0	SY563T	x ¹	x ¹	
A1	SY873T	x ¹	x ¹	x ¹
A2	SMx60 xx xxx 8 11 ...	x ¹	x ¹	
A3	SMx82 xx xx 8 14 ...		x ¹	x ¹
A7	PS60		x ¹	x ¹
C0	LP050 / PV40-TA	x ¹	x ¹	
C1	LP070 / PV60-TA		x ¹	x ¹

x¹: If a mounting kit is selected the **drive shaft** is a plain shaft

Info: Motor and gear mounting dimensions see page 191

P-A4P017GB

OSP-E

Piston Rod Mounting * see page 155 ff

0	without
T	Piston Rod Eye
U	Piston Rod Clevis
V	Piston Rod Compensating Coupling

Niro

0	Standard
1*	Niro Screws

Magnetic Sensors * see page 165 ff

0	without
1	1 pc. RS-K 2NO / 5 m Cable
2	1 pc. RS-K 2NC / 5 m Cable
3	2 pc. RS-K 2NC / 5 m Cable
4	2 pc. RS-K 2NC, 1 pc. RS-K 2NO / 5 m Cable
D	1 pc. ES-S PNP / M8 plug
E	2 pc. ES-S PNP / M8 plug
F	3 pc. ES-S PNP / M8 plug

Profile Mounting * see page 141 ff

0	Without
1	1 Pair Type 1
2	1 Pair Type D1
3	1 Pair Type MAE
4	2 Pair Type 1
5	2 Pair Type D1
6	2 Pair Type MAE
7	3 Pair Type 1
8	3 Pair Type D1
9	3 Pair Type MAE
see page 154	
K	1 Pair Trunnion Mounting EN
L	1 Pair Trunnion EN and Pivot Mounting EL

End Cap Mounting * see pages 141 ff

0	without
1	1 pc. Type A1SR (size 25 and 32) or C1SR (size 50)
2	1 pc. Type C-E

Accessories - please order separately

Description	Page
Motor Mountings	137 ff
Multi-Axis Systems for Actuators	177 ff

* Option

P-A4P017GB

OSP-E

Linear Guides

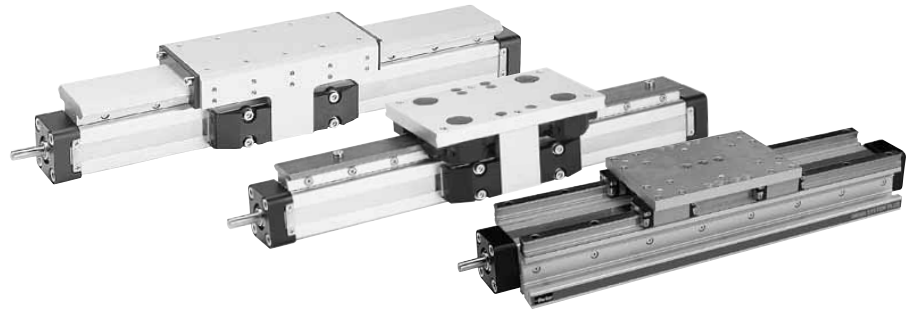

Content

Description	Page
Overview	100
SLIDELINE - Plain Bearing Guide	101
POWERSLIDE - Roller Guide	103
PROLINE - Aluminium Roller Guide	107
HD - Heavy Duty Guide	111

Adaptive Modular System

The Origa System Plus – OSP – provides a comprehensive range of linear guides for the pneumatic and electric actuators.

Versions:

Electric Acuator Series:

- **OSP-E..B**
- **OSP-E..SB**
- **OSP-E..ST**
- **Sizes** 25, 32, 50

Advantages:

- Takes High Loads and Moments
- High Precision
- Smooth Operation
- Can be Retrofitted
- Can be Installed in any Position

Electric Acuator

- Series **OSP-E..B** (Belt)
- Series **OSP-E..SB** (Ball Screw)
- Series **OSP-E..ST** (Trapezoidal Screw)

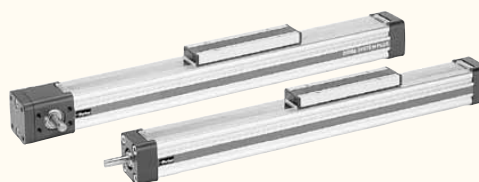

SLIDELINE

The cost-effective plain bearing guide for medium loads.
– for screw actuators only Series OSP-E..SB, OSP-E..ST

see page 101ff

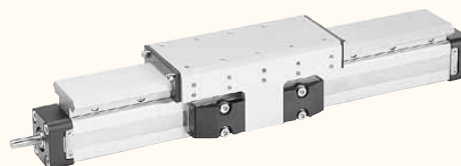

POWERSLIDE

The roller guide for heavy loads.

see page 103ff

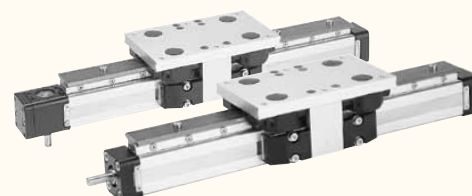

PROLINE

The ball bushing guide for heavy loads and speed.

see page 107ff

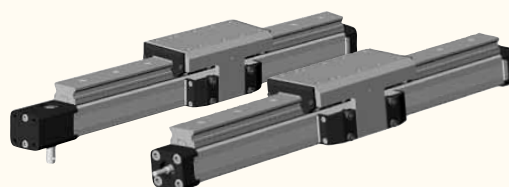

HD-Guide (heavy-duty guide)

The ball bearing guide for the heaviest loads and greatest accuracy.

– for Screw Actuators only Series OSP-E..SB, OSP-E..ST

see page 111ff

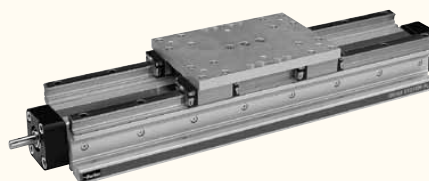

P-A4P017GB

OSP-E

SLIDELINE Plain Bearing Guide

Series SL 25 to 50 for for Actuator

- Series OSP-E Screw

Technical Data

The table shows the maximum permissible values for smooth operation, which must not be exceeded even under dynamic conditions.

The load and moment figures apply to speeds $v < 0.2$ m/s.

Features

- Anodised Aluminium Guide Rail with Prism-Shaped Slideway Arrangement
- Adjustable Plastic Slide Elements
- Composite Sealing System with Plastic and Felt Wiper Elements to Remove Dirt and Lubricate the Slideways.
- Corrosion-resistant Version Available on request.

Versions

- for Electric Actuator Series OSP-E Screw

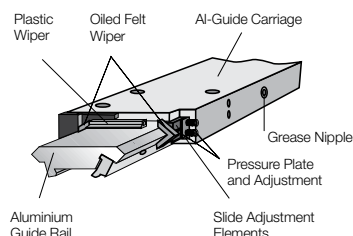

Loads, Forces and Moments

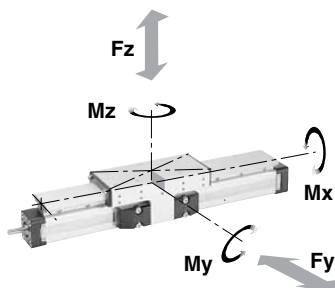

Series	Max. Moments [Nm]			Max. Load [N]	Mass of Drive with Guide [kg]		Weight Carriage [kg]	Order No. SLIDELINE ¹⁾ without break for OSP-E Screw
	M_x	M_y	M_z		0 mm Stroke	per 100 mm Stroke		
				F	OSP-E Screw	OSP-E Screw		
SL25	14	34	34	675	1.8	0.42	0.61	20342FIL
SL32	29	60	60	925	3.6	0.73	0.95	20196FIL
SL50	77	180	180	2,000	8.7	1.44	2.06	20195FIL

¹⁾ Corrosion resistant fixtures available on request

Guide Mountings see page 149



P-A4P017GB

OSP-E

Dimensions

Series OSP-E Screw

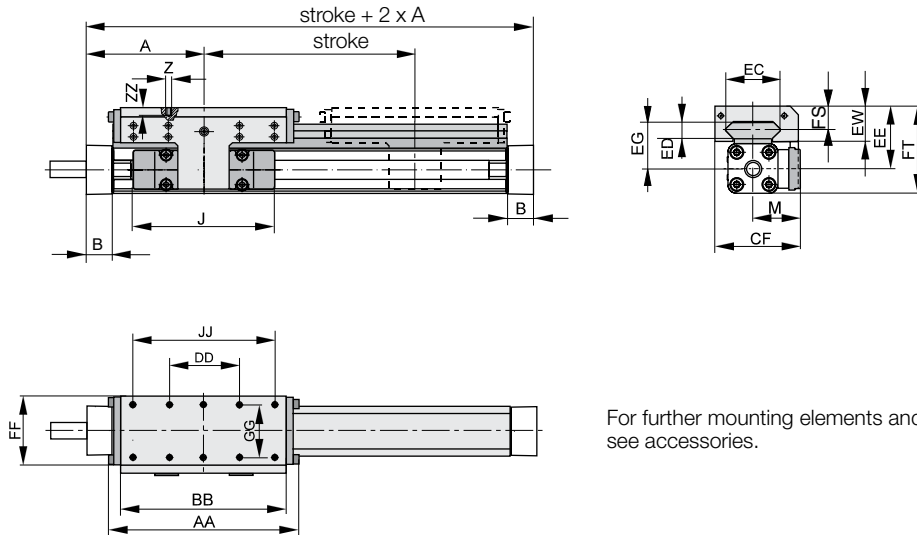

For further mounting elements and options see accessories.

Dimension Table [mm]

Series	A	B	J	M	Z	AA	BB	DD	CF	EC	ED	EE	EG	EW	FF	FT	FS	GG	JJ	ZZ
SL 25	100	22.0	117	40.5	M6	162	142	60	72.5	47	12	53	39	30	64	73.5	20	50	120	12
SL 32	125	25.5	152	49.0	M6	205	185	80	91.0	67	14	62	48	33	84	88.0	21	64	160	12
SL 50	175	33.0	200	62.0	M6	284	264	120	117	94	14	75	56	39	110	118.5	26	90	240	16

Guide Mounting (see page 149)

Guide mountings are required from a certain stroke length to prevent excessive deflection and vibration of the actuator. The diagrams show the maximum permissible unsupported length in relation to loading.

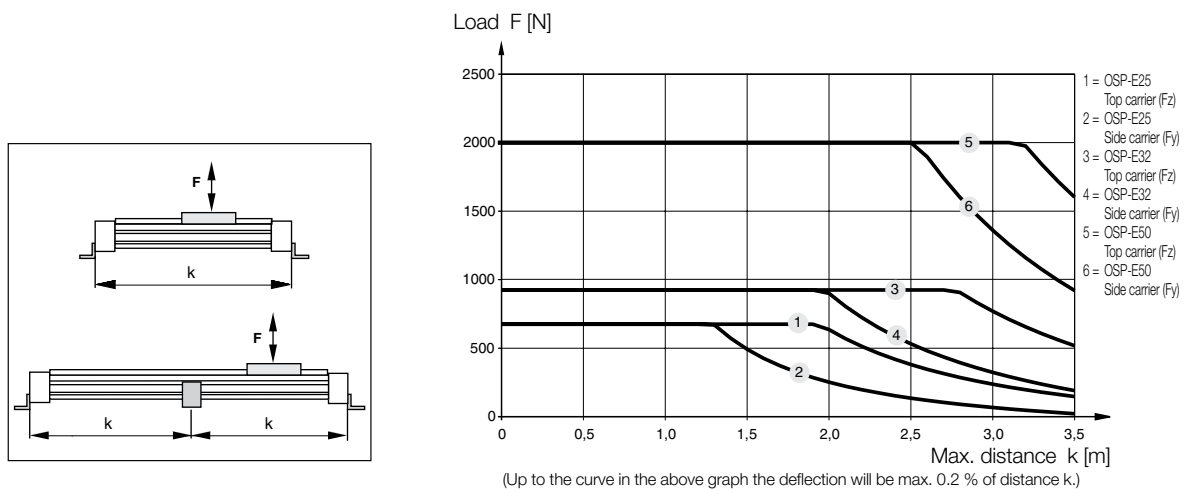
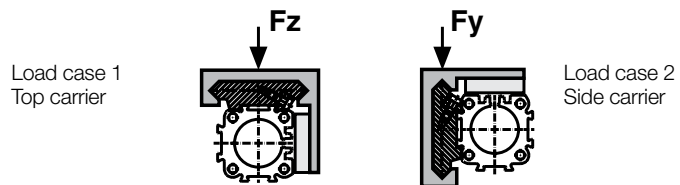

P-A4P017GB

OSP-E

POWERSLIDE Roller Guide

Series PS 25 to 50 for Acuator

- Series OSP-E Belt *
- Series OSP-E Screw

* Series PS for OSP-E Bi-parting version on request

Technical Data

The table shows the maximum permissible values for smooth operation, which must not be exceeded even under dynamic conditions.

For further information and technical data see data sheets for actuators.

Versions

– for Electric Acuator:
Series OSP-E Belt
Series OSP-E Screw



Features:

- Anodised Aluminium Guide Carriage with Vee Rollers Having 2 Rows of Ball Bearings
- Hardened Steel Guide Rail
- Several Guide Sizes Can be Used on the Same Drive
- Max. Speed $v = 3 \text{ m/s}$
- Tough Roller Cover With Wiper and Grease Nipple
- Any Length of Stroke Up To 3,500 mm (longer strokes on request). The Maximum Stroke Lengths of Actuators OSP-E..B, OSP-E..SB and OSP-E..ST must be observed.

OSP-E Belt: For position of guides see page109

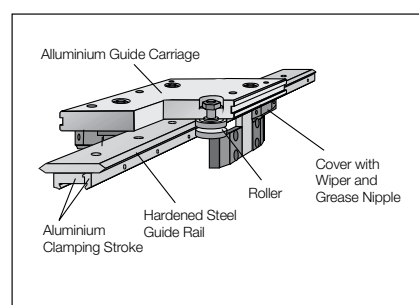

Loads, Force and Moment

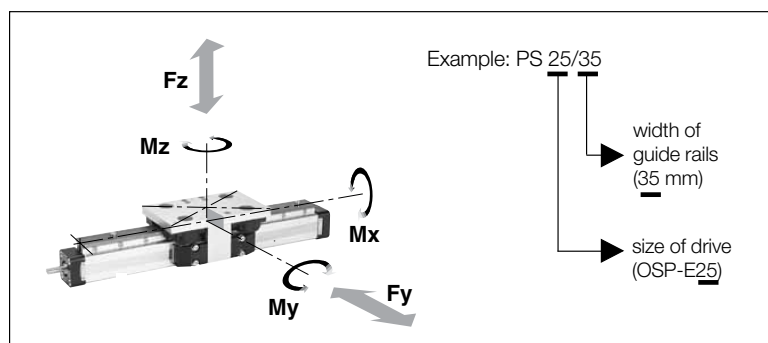

Series	Max. Moments [Nm]			Max. Load [N]	Mass of Drive with Guide [kg]				Mass * of Guide Carriage [kg]	Order No. Powerslide for	
	M_x	M_y	M_z		F_y, F_z	with 0 mm Stroke		increase per 100 mm Stroke		OSP-E* Belt	OSP-E Screw
PS 25/25	14	63	63	910	OSP-E Belt	OSP-E Screw	OSP-E Belt	OSP-E Screw	0.7	20304FIL	20015FIL
PS 25/32	17	70	70	1,010	2.1	1.9	0.34	0.41	0.8	20305FIL	20016FIL
PS 25/44	20	175	175	1,190	3.0	2.7	0.42	0.49	1.5	20306FIL	20017FIL
PS 32/35	20	70	70	1,400	3.1	3.2	0.51	0.63	0.8	20307FIL	20286FIL
PS 32/44	50	175	175	2,300	4.0	4.1	0.59	0.70	1.5	20308FIL	20287FIL
PS 50/60	90	250	250	3,000	8.8	8.7	1.04	1.36	2.3	20309FIL	20288FIL
PS 50/76	140	350	350	4,000	12.2	12.0	1.28	1.6	4.9	20310FIL	20289FIL

Mountings see page 149



P-A4P017GB

OSP-E

Dimensions - Series OSP-E Belt

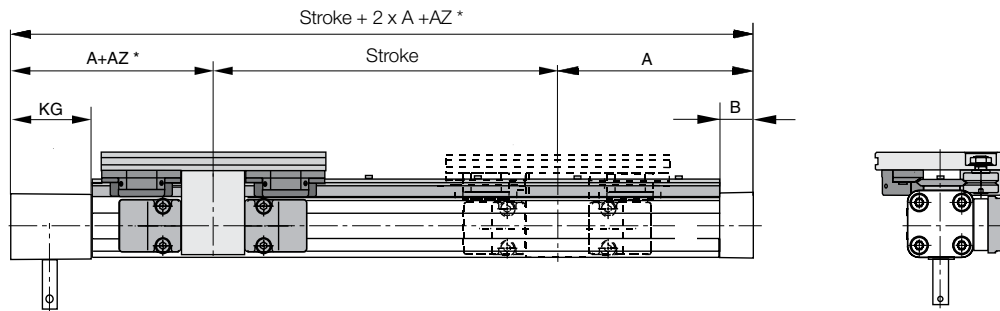

* **Please note:** The dimension „AZ“ must be added to „A“. Stroke length to order is stroke + dimension „AZ“ + safety clearance. Please also note the effect of dimension „AZ“ when retrofitting a guide – contact your local Parker technical support department.

Dimensions - Series OSP-E Screw

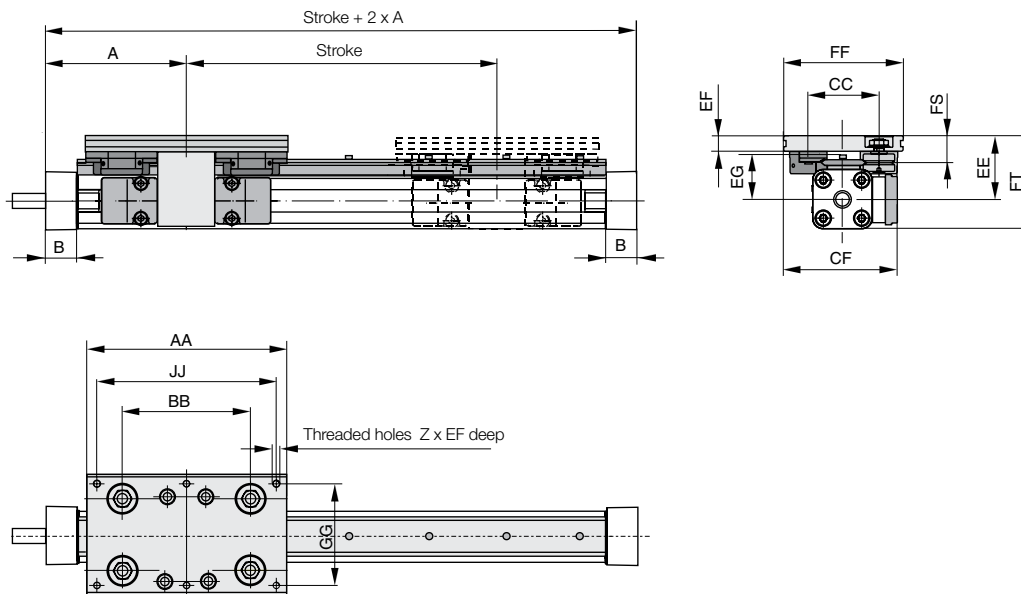

Dimensions [mm]

Series	A		B		Z	AA	AZ	BB	CC	CF	EE	EF	EG	FF	FS	FT	GG	JJ	KG
	OSP-E Belt	OSP-E Screw	OSP-E Belt	OSP-E Screw															
PS 25/25	125	100	22	22.0	6 x M6	145	5	90	47	79.5	53.0	11.0	39.0	80	20.0	73.5	64	125	57
PS 25/35	125	100	22	22.0	6 x M6	156	10	100	57	89.5	52.5	12.5	37.5	95	21.5	73.0	80	140	57
PS 25/44	125	100	22	22.0	6 x M8	190	27	118	73	100.0	58.0	15.0	39.0	116	26.0	78.5	96	164	57
PS 32/35	150	125	25	25.5	6 x M6	156	-	100	57	95.5	58.5	12.5	43.5	95	21.5	84.5	80	140	61
PS 32/44	150	125	25	25.5	6 x M8	190	6	118	73	107.0	64.0	15.0	45.0	116	26.0	90.0	96	164	61
PS 50/60	200	175	25	33.0	6 x M8	240	5	167	89	130.5	81.0	17.0	61.0	135	28.5	123.5	115	216	85
PS 50/76	200	175	25	33.0	6 x M10	280	25	178	119	155.5	93.0	20.0	64.0	185	39.0	135.5	160	250	85

P-A4P017GB

OSP-E

OSP-E Belt – If Combined with a Linear Guide, please also state position of Linear Guide!

Position of Drive Shaft
Standard = 0

Position of Linear Guide
Standard Position of the Guide on the Opposite Side of the Drive Shaft
Opposite to Standard Position of the Guide on the Side of the Drive Shaft

Position of Drive Shaft
Opposite to Standard = 1

Position of Linear Guide
Standard Position of the Guide on the Opposite Side of the Drive Shaft
Opposite to Standard Position of the Guide on the Side of the Drive Shaft

Position of Drive Shaft
Both Sides = 2

Position of Linear Guide
Standard Position of the Guide on the Opposite Side of the Drive Shaft
Opposite to Standard Position of the Guide on the Side of the Drive Shaft

Load Case 1 - Top Carrier

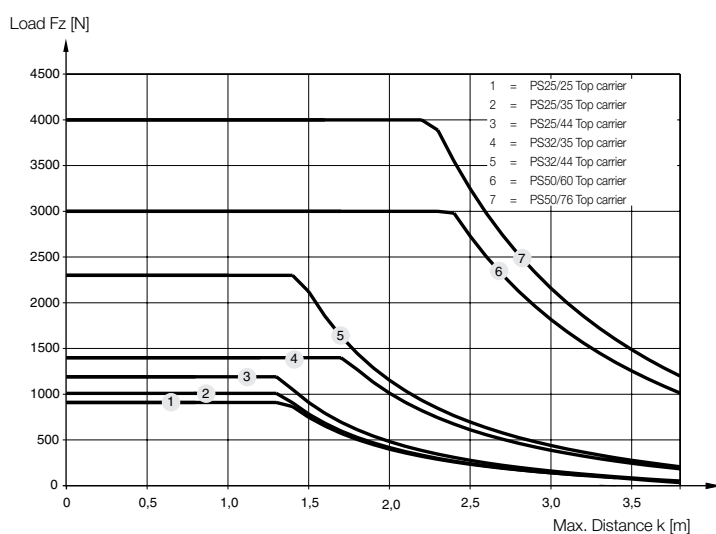

(Up to the curve in the above graph the deflection will be max. 0.2% of distance k)

Guide Mounting (see page 149)

Guide mountings are required from a certain stroke length to prevent excessive deflection and vibration of the actuator. The diagrams show the maximum permissible unsupported length in relation to loading.

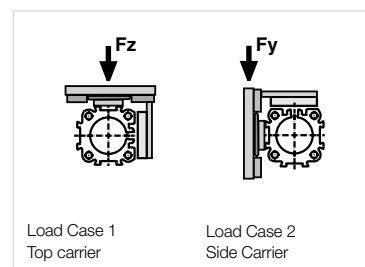

Load Case 2 - Side Carrier

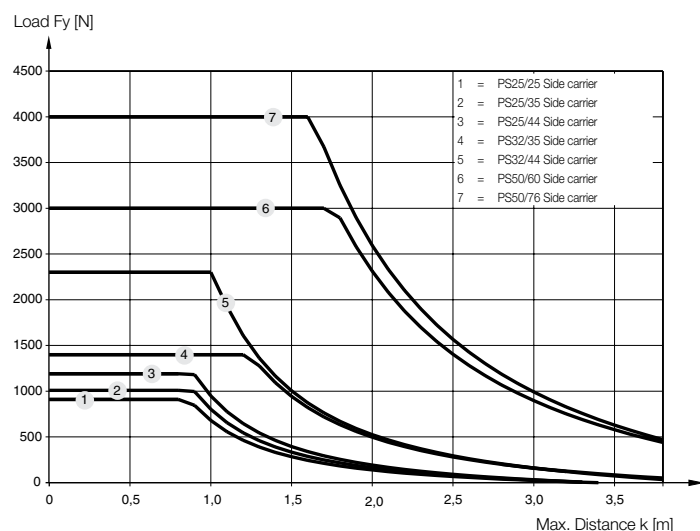

(Up to the curve in the above graph the deflection will be max. 0,2 % of distance k)

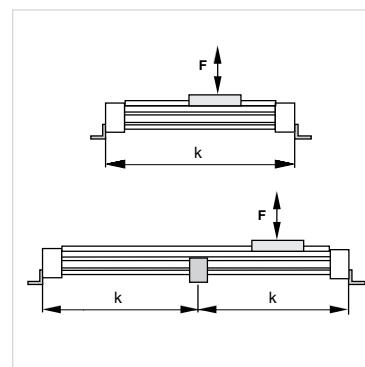

P-A4P017GB

OSP-E

1. Calculation of Load Factor L_F

Performance

Calculation of performance is achieved in two stages:

- Determination of load factor L_F from the loads to be carried
- Calculation of service life in km

$$L_F = \frac{F_y}{F_{y \max}} + \frac{F_z}{F_{z \max}} + \frac{M_x}{M_{x \max}} + \frac{M_y}{M_{y \max}} + \frac{M_z}{M_{z \max}}$$

with combined loads, L_F must not exceed the value 1

2. Calculation of Performance

Lubrication

For maximum system life, lubrication of the rollers must be maintained at all times.

Only high quality lithium-based greases should be used.

Lubrication intervals are dependent on environmental conditions (temperature, running speed, grease quality etc.) therefore the installation should be regularly inspected.

- For PS 25/25, PS 25/35 and PS 32/35: $\text{Service life [km]} = \frac{106}{(L_F + 0,02)^3}$
- For PS 25/44, PS 32/44 and PS 50/60: $\text{Service life [km]} = \frac{314}{(L_F + 0,015)^3}$
- For PS 50/76: $\text{Service life [km]} = \frac{680}{(L_F + 0,015)^3}$

P-A4P017GB

OSP-E

PROLINE Aluminium Roller Guide

Series PL 25 to 50 for Acuator

- Series OSP-E Belt *
- Series OSP-E Screw

Features:

- High Precision
- High Velocities (10 m/s)
- Smooth Operation - Low Noise
- Integrated Wiper System

- Life Time Lubrication
- Compact Dimensions - Compatible to Slideline Plain Bearing Guide
- Version available up to 3,750 mm
The maximum stroke lengths of actuators OSP-E..B, OSP-E..SB and OSP-E..ST must be observed

* Series PL for OSP-E Bi-parting version on request.

Versions

- For Electric Acuator:
- Series OSP-E Belt
- Series OSP-E Screw

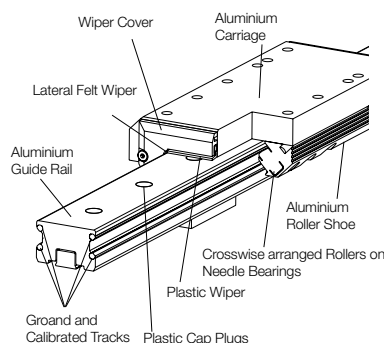

Loads, Forces and Moments

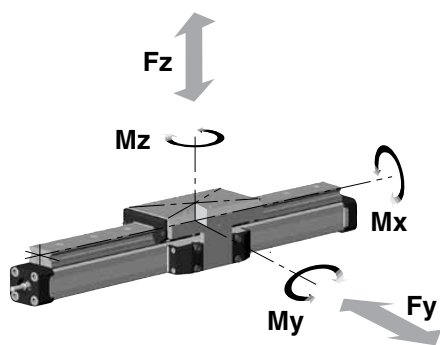

Technical Data

The table shows the maximum permissible loads. If multiple moments and forces act upon the cylinder simultaneously, the following equation applies:

$$\frac{F_y}{F_{y \max}} + \frac{F_z}{F_{z \max}} + \frac{M_x}{M_{x \max}} + \frac{M_y}{M_{y \max}} + \frac{M_z}{M_{z \max}} \leq 1$$

With a load factor of ≤ 1 , the service life is 5000 km.

The sum of the loads must not exceed > 1 .

The table shows the maximum permissible values for light, shock-free operation, which must not be exceeded even under dynamic conditions.

Series	Max. Moments [Nm]			Max. Load [N]	Mass of Drive with Guide [kg]				Mass Guide Carriage [kg]	Order No. PROLINE ¹⁾ for	
	M _x	M _y	M _z		F _y , F _z	bei 0 mm Stroke	OSP-E Screw	OSP-E Belt		OSP-E Screw	OSP-E* Belt
PL25	19	44	44	986	1.9	1.8	0.33	0.40	0.75	20874FIL	20856FIL
PL32	33	84	84	1,348	3.6	3.7	0.58	0.70	1.18	20875FIL	20857FIL
PL50	128	287	287	3,582	8.9	8.8	1.00	1.32	2.50	20876FIL	20859FIL

¹⁾ Stainless steel on request



P-A4P017GB

OSP-E

Dimensions Series OSP-E Belt PL25, PL32, PL50

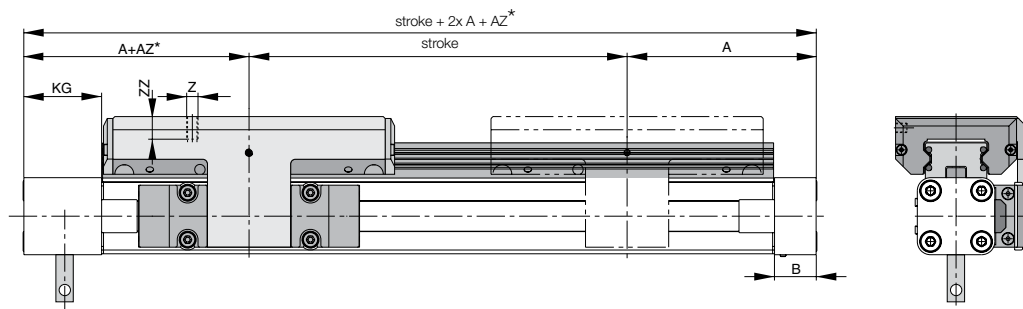

***Please note:** Dimension "AZ" must be added to dimension "A". The stroke to be ordered will be: stroke + min. dimension "AZ" + additional length. Please observe the effect of dimension "AZ" when retrofitting a guide. Please contact our application engineers.

Dimension Table [mm] Series OSP-E Belt PL25, PL32, PL50

Series	A	B	J	M	Z	AA	AZ	BB	DD	CF	EC	EE	EG	FF	FS	FT	GG	JJ	KG	ZZ
PL25	125	22	117	40.5	M6	154	10	144	60	72.5	32.5	53	39	64	23	74.0	50	120	57	12
PL32	150	25	152	49.0	M6	197	11	187	80	91.0	42.0	62	48	84	25	88.0	64	160	61	12
PL50	200	25	200	62.0	M6	276	24	266	120	117.0	63.0	75	57	110	29	118.0	90	240	85	16

Dimensions Series OSP-E Screw PL25, PL32, PL50

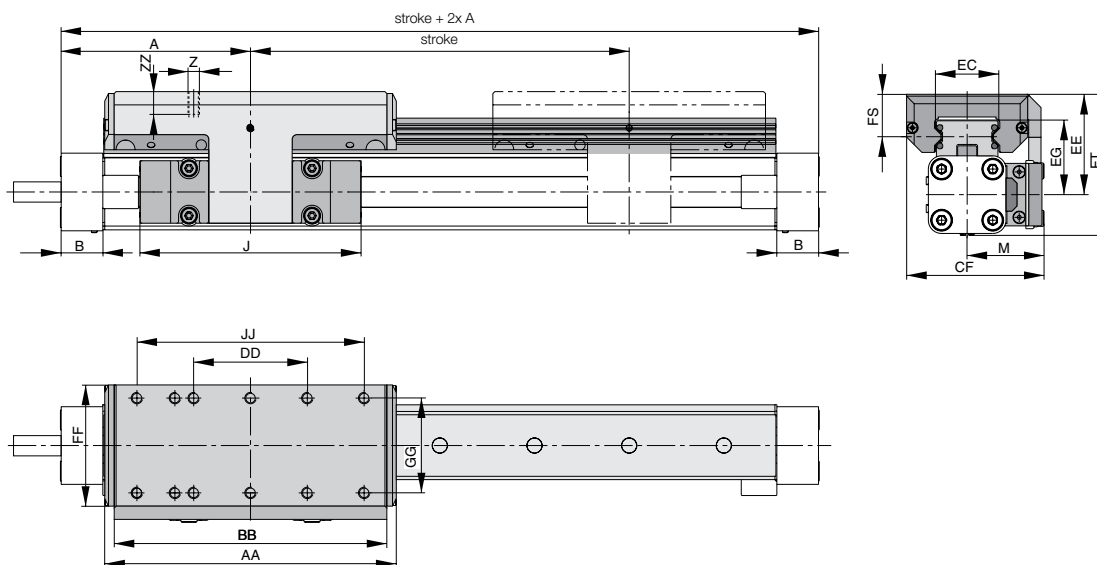

Dimension Table [mm] OSP-E Screw PL25, PL32, PL50

Series	A	B	J	M	Z	AA	BB	DD	CF	EC	EE	EG	FF	FS	FT	GG	JJ	ZZ
PL25	100	22	117	40.5	M6	154	144	60	72.5	32.5	53	39	64	23	74	50	120	12
PL32	125	25.5	152	49.0	M6	197	187	80	91.0	42.0	62	48	84	25	88	64	160	12
PL50	175	33.0	200	62.0	M6	276	266	120	117.0	63.0	75	57	110	29	118	90	240	16

P-A4P017GB

OSP-E

OSP-E Belt – If combined with a linear guide, please also state position of linear guide!

Position of Drive Shaft Standard = 0

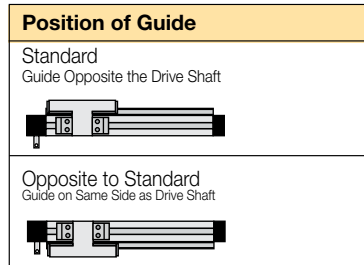

Position of Drive Shaft Opposite to Standard = 1

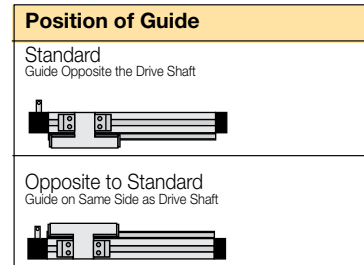

Position of Drive Shaft Both Sides = 2

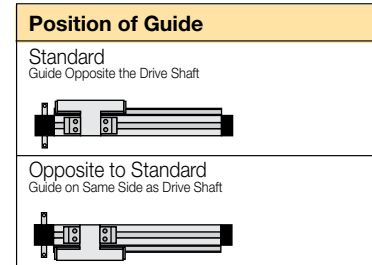

Guide Mounting (see page 149)

Guide mountings are required from a certain stroke length to prevent excessive deflection and vibration of the actuator. The diagrams show the maximum permissible unsupported length in relation to loading.

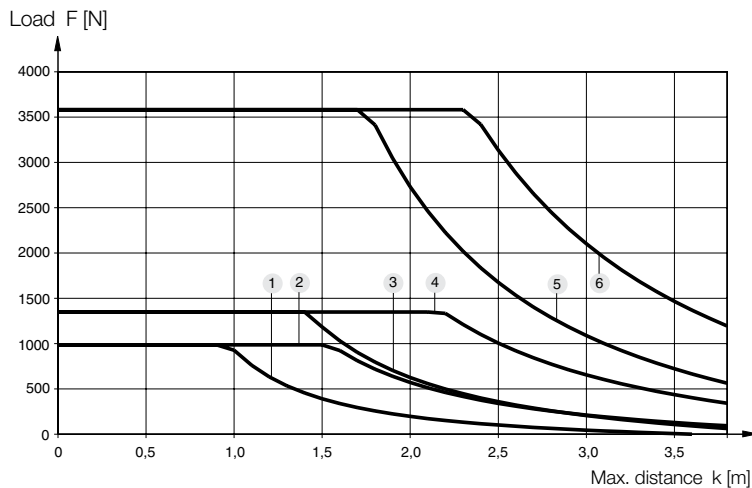

(Up to the curve in the above graph the deflection will be max. 0.2 % of distance k.)

- 1 = OSP-E25 Side carrier (Fy)
- 3 = OSP-E32 Side carrier (Fy)
- 5 = OSP-E50 Side carrier (Fy)
- 2 = OSP-E25 Top carrier (Fz)
- 4 = OSP-E32 Top carrier (Fz)
- 6 = OSP-E50 Top carrier (Fz)

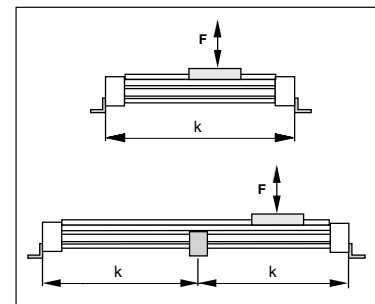
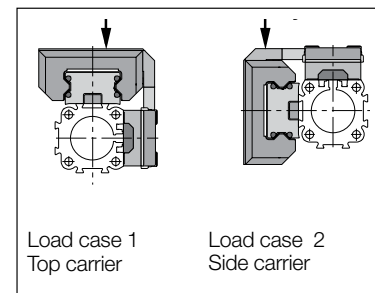

P-A4P017GB

OSP-E

P-A4P017GB

OSP-E

HD Heavy Duty Guide

Series HD 25 to 50 for Actuator

- Series OSP-E..SB, ..ST

Features:

- Guide System 4-row Ball Bearing Guide
- Polished and Hardened Guide Rails of Steel
- For Highest Loads in all Directions
- Highest Precision
- Integrated Wiper
- Grease Nipple for Relubrication
- Anodized Guide Carriage with the Same Connecting Dimensions as OSP-Guide GUIDELINE
- Maximum Velocity $v = 5 \text{ m/s}$

Version - for Electric Actuator: Series OSP-E Screw

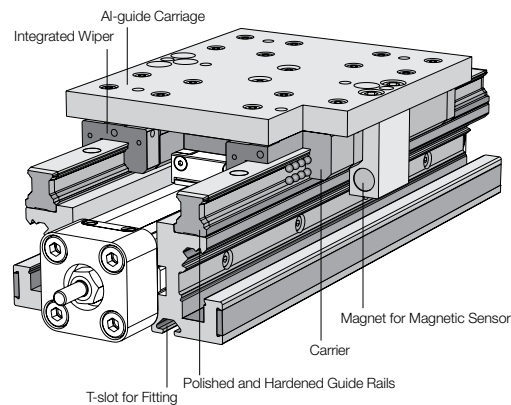

Loads, Forces and Moments

OSP-E..SB, ..ST

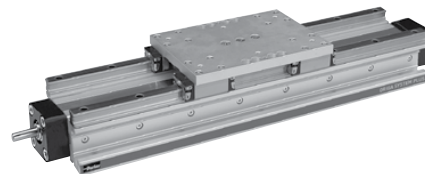
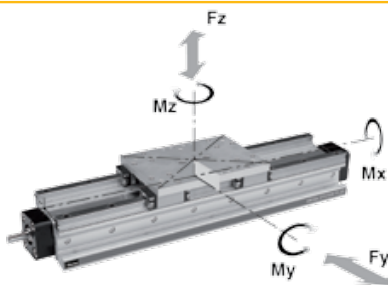

Technical Data

For the maximum permissible loads please refer to the table below. If several forces and moments loads act upon the guide simultaneously, the following equation will apply:

$$\frac{F_y}{F_{y \max}} + \frac{F_z}{F_{z \max}} + \frac{M_x}{M_{x \max}} + \frac{M_y}{M_{y \max}} + \frac{M_z}{M_{z \max}} \leq 1$$

The total of the loads must not exceed > 1 under any circumstances.

The table shows the maximum permissible values for light, shock-free operation which must not be exceeded even under dynamic conditions.

Series	Max. Moments [Nm]			Max. Load [N]		Mass of Acuator with Guide [kg]				Mass Guide-Carrier [kg]	Order No. HD-Guide for OSP-E
	M_x	M_y	M_z	F_y	F_z	at 0 mm stroke		increase per 100 mm stroke			
	M_x	M_y	M_z	F_y	F_z	OSP-E..SB	OSP-E..ST	OSP-E..SB	OSP-E ..ST	[kg]	
HD 25	260	320	320	6,000	6,000	3,215	3,315	0,957	1,007	1,289	21246FIL
HD 32	285	475	475	6,000	6,000	4,868	4,968	1,198	1,258	1,367	21247FIL
HD 50	1,100	1,400	1,400	18,000	18,000	13,218	13,318	2,554	2,674	3,551	21249FIL



P-A4P017GB

OSP-E

Dimension Series OSP-E Screw HD25, HD32, HD50

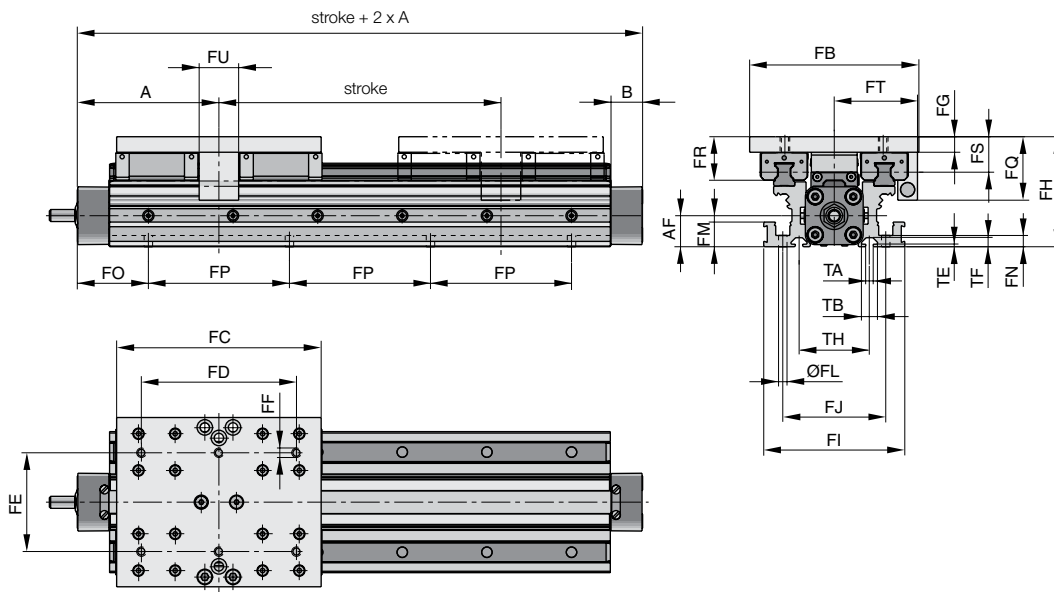

Hint: The heavy-duty guide HD must be fitted to a level surface over the entire length. If T-nuts are used, the distance between them must not exceed 100 mm.

Arrangement of Magnetic Sensors:

The magnetic sensors can be fitted to either side over the entire length.

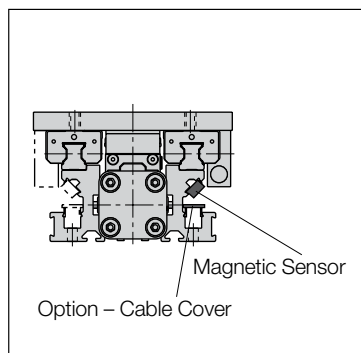

P-A4P017GB

OSP-E

Dimension Table [mm]

Series	A	B	AF	FB	FC	FD	FE	FF	FG	FH	FI	FJ	ØFL
HD25	100	22.0	22	120	145	110	70	M6	11	78	100	73	6.0
HD32	125	25.5	30	120	170	140	80	M6	11	86	112	85	6.0
HD50	175	33.0	48	180	200	160	120	M8	14	118	150	118	7.5

Series	FM	FN	FP	FQ	FR	FS	FT	FU	TA	TB	TE	TF	TH
HD25	17.5	8	100	45	31	25.0	59	28	5.2	11.5	1.8	6.4	50
HD32	17.5	8	100	45	31	25.0	63	30	5.2	11.5	1.8	6.4	60
HD50	22.0	10	100	58	44	35.5	89	30	8.2	20.0	4.5	12.3	76

FO			
OSP-E..SB. ...ST			
x	HD25	HD32	HD50
00	50.0	75.0	75.0
01	50.5	75.5	75.5
02	51.0	76.0	76.0
03	51.5	76.5	76.5
04	52.0	77.0	77.0
05	52.5	77.5	77.5
06	53.0	78.0	78.0
07	53.5	78.5	78.5
08	54.0	79.0	79.0
09	54.5	79.5	79.5
10	55.0	80.0	80.0
11	55.5	80.5	80.5
12	56.0	81.0	81.0
13	56.5	81.5	81.5
14	57.0	82.0	82.0
15	57.5	82.5	82.5
16	58.0	83.0	83.0
17	58.5	83.5	83.5
18	59.0	84.0	84.0
19	59.5	84.5	84.5
20	60.0	85.0	85.0
21	60.5	85.5	85.5
22	61.0	36.0	86.0
23	61.5	36.5	86.5
24	62.0	37.0	87.0
25	62.5	37.5	87.5
26	63.0	38.0	88.0
27	63.5	38.5	88.5
28	64.0	39.0	89.0
29	64.5	39.5	89.5
30	65.0	40.0	90.0
31	65.5	40.5	90.5
32	66.0	41.0	91.0

FO			
OSP-E..SB. ...ST			
x	HD25	HD32	HD50
33	66.5	41.5	91.5
34	67.0	42.0	92.0
35	67.5	42.5	92.5
36	68.0	43.0	93.0
37	68.5	43.5	43.5
38	69.0	44.0	44.0
39	69.5	44.5	44.5
40	70.0	45.0	45.0
41	70.5	45.5	45.5
42	71.0	46.0	46.0
43	71.5	46.5	46.5
44	72.0	47.0	47.0
45	72.5	47.5	47.5
46	73.0	48.0	48.0
47	73.5	48.5	48.5
48	74.0	49.0	49.0
49	74.5	49.5	49.5
50	75.0	50.0	50.0
51	75.5	50.5	50.5
52	76.0	51.0	51.0
53	76.5	51.5	51.5
54	77.0	52.0	52.0
55	77.5	52.5	52.5
56	78.0	53.0	53.0
57	78.5	53.5	53.5
58	79.0	54.0	54.0
59	79.5	54.5	54.5
60	80.0	55.0	55.0
61	80.5	55.5	55.0
62	81.0	56.0	56.0
63	82.0	56.5	56.5
64	82.0	57.0	57.0
65	82.5	57.5	57.5

FO			
OSP-E..SB. ...ST			
66	33.0	58.0	58.0
67	33.5	58.5	58.5
68	34.0	59.0	59.0
69	34.5	59.5	59.5
70	35.0	60.0	60.0
71	35.5	60.5	60.5
72	36.0	61.0	61.0
73	36.5	61.5	61.5
74	37.0	62.0	62.0
75	37.5	62.5	62.5
76	38.0	63.0	63.0
77	38.5	63.5	63.5
78	39.0	64.0	64.0
79	39.5	64.5	64.5
80	40.0	65.0	65.0
81	40.5	65.5	65.5
82	41.0	66.0	66.0
83	41.5	66.5	66.5
84	42.0	67.0	67.0
85	42.5	67.5	67.5
86	43.0	68.0	68.0
87	43.5	68.5	68.5
88	44.0	69.0	69.0
89	44.5	69.5	69.5
90	45.0	70.0	70.0
91	45.5	70.5	70.5
92	46.0	71.0	71.0
93	46.5	71.5	71.5
94	47.0	72.0	72.0
95	47.5	72.5	72.5
96	48.0	73.0	73.0
97	48.5	73.5	73.5
98	49.0	74.0	74.0
99	49.5	74.5	74.5

Note:

The dimension FO is derived from the last two digits of the stroke:

Sample:
stroke 15**25** mm



For a cylinder OSP-E25 the table shows that for x = 25 mm:
FO = 62.5 mm

P-A4P017GB

OSP-E

P-A4P017GB
OSP-E

PS / RS Planetary / Angular Gears



P-A4P017GB

OSP-E

Planetary Gears - Series PS60, PS90, PS115

The requirements between transmissible power and size of gear is defined by the use and required resolution. A gear can be used to reduce the required torque of the motor and to achieve a good inertia mismatch.

The PS gear boxes incorporate dual angular contact bearings, providing higher radial load capacities while maintaining high input speeds. The lifetime expectancy of newly designed needle bearings is significantly high.

Maintenance: The PS series is lifetime lubricated.

Technical Data PS60

Characteristics	Symbol	Unit	1-stage			2-stage		
Ratio	i		3	5	10	20	50	100
Normal Torque	T _{nom}	Nm	27	37	32	37	37	32
Maximum Acceleration Torque	T _{acc}	Nm	34	48	37	48	48	37
Emergency Stop	T _{em}	Nm	80	70	60	70	70	60
Nominal Speed	N _{nom}	min ⁻¹	3,000	3,500	4,000	4,500	4,800	5,200
Maximum Speed	N _{max}	min ⁻¹	6.000					
Inertia	J	kgcm ²	0.25	0.15	0.14	0.15	0.13	0.13
Backlash		arcmin	<6			<8		
Efficiency at Normal Torque	η	%	97			94		
Operating Noise at 3000 min ⁻¹		dB(A)	<62					
Lifetime		h	>20.000					
Protection Class		IP	65					
Operating Temperature		°C	- 20 to +90					
Weight	m	kg	1.3			1.7		

Technical Data PS90

Characteristics	Symbol	Unit	1-stage			2-stage		
Ratio	i		3	5	10	20	50	100
Normal Torque	T _{nom}	Nm	76	110	93	110	110	93
Maximum Acceleration Torque	T _{acc}	Nm	105	123	112	123	123	112
Emergency Stop	T _{em}	Nm	260	230	200	230	230	200
Nominal Speed	N _{nom}	min ⁻¹	2,500	3,000	3,500	4,000	4,400	4,800
Maximum Speed	N _{max}	min ⁻¹	5,500					
Inertia	J	kgcm ²	0.97	0.51	0.37	0.51	0.37	0.37
Backlash		arcmin	<6			<8		
Efficiency at Normal Torque	η	%	97			94		
Operating Noise at 3000 min ⁻¹		dB(A)	<62					
Lifetime		h	>20.000					
Protection Class		IP	65					
Operating Temperature		°C	- 20 to +90					
Weight	m	kg	3.0			5.0		



P-A4P017GB

OSP-E

Planetary Gears - Series PS60, PS90, PS115

Technical Data PS115

Characteristics	Symbol	Unit	1-stage			2-stage		
			3	5	10	20	50	100
Ratio	i		3	5	10	20	50	100
Nominal Torque	T _{nom}	Nm	172	230	205	230	230	205
Maximum Acceleration Torque	T _{acc}	Nm	225	285	240	285	285	240
Emergency Stop	T _{em}	Nm	600	500	430	500	500	430
Nominal Speed	N _{nom}	min ⁻¹	2,000	2,500	3,000	3,500	3,800	4,200
Maximum Speed	N _{max}	min ⁻¹	4,500					
Inertia	J	kgcm ²	3.40	1.70	1.10	1.70	1.10	1.10
Backlash		arcmin	<4			<6		
Efficiency at Nominal Torque	η	%	97			94		
Operating Noise at 3000 min-1		dB(A)	<65					
Lifetime		h	>20,000					
Protection Class		IP	65					
Operating Temperature		°C	- 20 to +90					
Weight	m	kg	7.0			10.0		

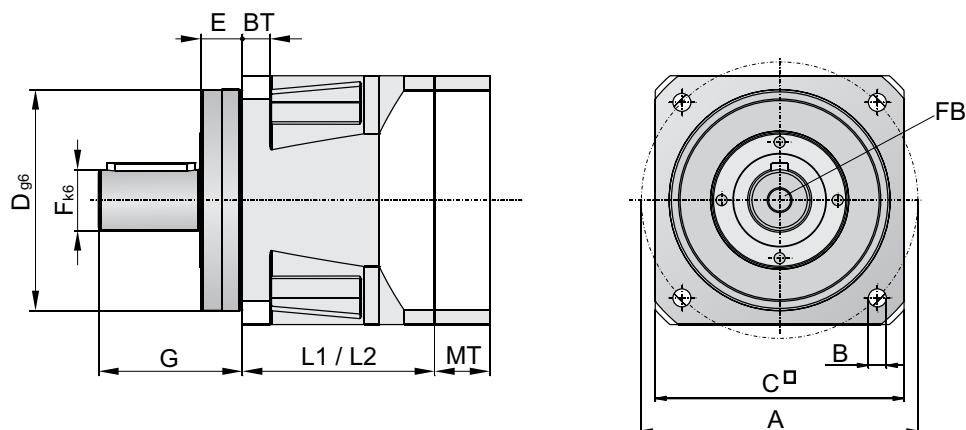

Dimension Table [mm]

Type	ø A	ø B	BT	C	ø D _{h6}	E	ø F _{k6}	FB	G
PS60	70	5.5	8	62	50	11.0	16	M5x8	40
PS90	100	6.5	10	90	80	15.0	22	M8x16	52
PS115	130	8.5	14	115	110	16.0	32	M12x25	68

Dimension Table [mm]

Type	MF*	MG**	MT	L1 (1-stage)	L2 (2-stage)
PS60	≤ 14	16 - 35	16.5	59.8	94.8
		> 35 - 41	22.5		
PS90	≤ 19	20 - 40	20.0	69.5	113.0
		> 40 - 48	28.5		
PS115	≤ 24	22 - 50	24.0	90.2	143.4
		> 50 - 61	35.0		

* MF = maximum diameter of motor shaft

** MG = length of motor shaft that specifies a thickness of motor flange MT



P-A4P017GB

OSP-E

Angular Gears - Series RS60, RS90, RS115

The requirements between transmissible power and size of gear is defined by the use and required resolution. A gear can be used to reduce the required torque of the motor and to achieve a good inertia mismatch.

The RS gear boxes incorporate dual angular contact bearings, providing higher radial load capacities while maintaining high input speeds. The lifetime expectancy of newly designed needle bearings is significantly high. An angular gear is often used if space is limited and a compact motor and a gear mounting is needed.

Maintenance: The RS series is lifetime lubricated.

Technical Data RS60

Characteristics	Symbol	Unit	1-stage		2-stage		
Ratio	i		5	10	20	50	100
Nominal Torque	T _{nom}	Nm	13	24	35	35	30
Maximum Acceleration Torque	T _{acc}	Nm	19	36	45	45	37
Emergency Stop	T _{em}	Nm	40	72	80	80	60
Nominal Speed	N _{nom}	min ⁻¹	3,200	3,200	3,700	4,200	4,200
Maximum Speed	N _{max}	min ⁻¹	6,000				
Inertia	J	kgcm ²	0.22	0.19	0.17	0.15	0.15
Backlash	η	arcmin	<14		<12		
Efficiency at Nominal Torque		%	94				
Operating Noise at 3,000 min ⁻¹		dB(A)	<65				
Lifetime		h	>20,000				
Protection		IP	65				
Operating Temperature		°C	- 20 to +90				
Weight	m	kg	2.0				

Technical Data RS90

Characteristics	Symbol	Unit	1-stage		2-stage		
Ratio	i		5	10	20	50	100
Nominal Torque	T _{nom}	Nm	55	80	88	88	86
Maximum Acceleration Torque	T _{acc}	Nm	83	120	123	123	112
Emergency Stop	T _{em}	Nm	150	240	250	250	200
Nominal Speed	N _{nom}	min ⁻¹	2,800	2,800	3,300	3,800	3,800
Maximum Speed	N _{max}	min ⁻¹	5,300				
Inertia	J	kgcm ²	0.81	0.61	0.51	0.40	0.40
Backlash		arcmin	<12		<10		
Efficiency at Nominal Torque	η	%	94				
Operating Noise at 3000 min ⁻¹		dB(A)	<68				
Lifetime		h	>20,000				
Protection Class		IP	65				
Operating Temperature		°C	- 20 to +90				
Weight	m	kg	6.0				



P-A4P017GB

OSP-E

Angular Gears - Series RS60, RS90, RS115

Technical Data RS115

Characteristics	Symbol	Unit	1-stage		2-stage		
Ratio	i		5	10	20	50	100
Nominal torque	T _{nom}	Nm	85	160	220	220	195
Maximum acceleration torque	T _{acc}	Nm	127	240	255	255	240
Emergency stop	T _{em}	Nm	270	480	510	510	430
Nominal speed	N _{nom}	min ⁻¹	2,400	2,400	2,900	3,400	3,400
Maximum speed	N _{max}	min ⁻¹	4,500				
Inertia	J	kgcm ²	2.50	1.90	1.40	1.10	1.10
Backlash		arcmin	<12			<10	
Efficiency at nominal torque	η	%	94				
Operating noise at 3000 min ⁻¹		dB(A)	<68				
Lifetime		h	>20,000				
Protection		IP	65				
Operating temperature		°C	- 20 to +90				
Weight	m	kg	11,0				

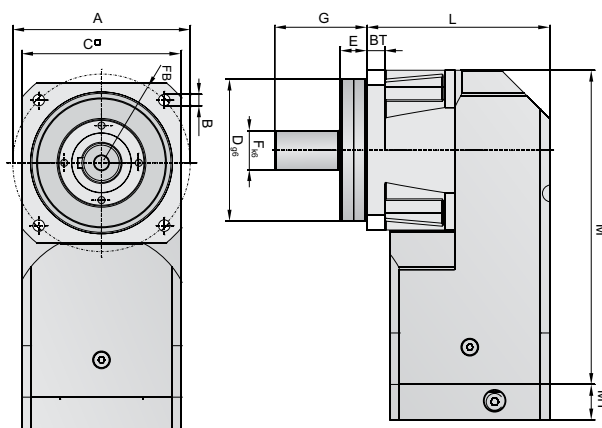

Dimension Table [mm]

Type	ø A	ø B	BT	□C	ø D _{h6}	E	ø F _{k6}	FB	G
RS60	70	5.5	8	62	50	11.0	16	M5x8	40
RS90	100	6.5	10	90	80	15.0	22	M8x16	52
RS115	130	8.5	14	115	110	16.0	32	M12x25	68

Dimension Table [mm]

Type	MF*	MG**	MT	H	L	M
RS60	≤ 14	16 - 35	16.5	47.0	76.8	124.7
		> 35 - 41	22.5			
RS90	≤ 19	20 - 40	20.0	58.0	103.0	177.0
		> 40 - 48	28.5			
RS115	≤ 24	22 - 50	24.0	74.0	132.0	211.0
		> 50 - 61	35.0			

*MF = maximum Diameter of motor shaft

**MG = length of motor shaft that specifies a thickness of motor flange MT



Parker Hannifin Corporation
Pneumatic Division - Europe

P-A4P017GB

OSP-E

P-A4P017GB
OSP-E

EasyDrive Packages



P-A4P017GB

OSP-E

EasyDrive Controller - Microstepping & Servo Controller

Microstepping Controller

The microstepping controller has outstanding characteristics, for both slow and fast movements. Its step resolution from 400 to 51,200 steps per revolution is freely programmable and allows ideal adjustment to requirements regarding speed and response characteristics.

Technical Data - Microstepping Controller

Characteristics	Symbol	Unit	
Output Voltage Motor	U_{bP}	VDC	48 - 80 (+5% to -15%)
Nominal Output Current	I_{nP}	A	5.6
Peak Output Current	I_{pP}	A	8
Motor Inductance		mH	0.5 to 20
Output Voltage Logic	U_{bL}	VDC	24 (+/- 12.5%)
Nominal Current Logic	I_{nL}	mA	250
Resolution Motor (freely selectable)		Inc./rev	400 to 51,200
Digital Inputs			5
Digital Outputs			3
Com Port			RS232
User Interface			EasyDrive
Certification			CE / UL (E194158)

Servo Controller

The servo controller should be selected for dynamic motion profiles, since it can deliver for the motor a peak current which is 3 times higher than the rated current. Optimising the closed loop parameters allows the system consistency to be adapted to the individual application's requirements and thus generate an excellent motion profile.

The EasyDrive user menu allows you to do commissioning quickly and easily without the need to go through user manuals.

Technical Data - Servo Controller

Characteristics	Symbol	Unit	
Output Voltage Motor	U_{bP}	VDC	48 - 80 (+5% to -15%)
Nominal Output Current	I_{nP}	A	5
Peak Output Current	I_{pP}	A	15
Motor Inductance		mH	0.5 to 10
Output Voltage Logic	U_{bL}	VDC	24 (+/- 12.5%)
Nominal Current Logic	I_{nL}	mA	250
Resolver		pulses/rev	4,096
Digital Inputs			5
Digital Outputs			3
Com Port			RS232
User Interface			EasyDrive
Certification			CE / UL (E194158)

P-A4P017GB

OSP-E

EasyDrive Controller / Connectors

Supply and Motor Connector Terminal Block X1		
Pin	Connection	
	Microstepper	Servo
1	Motor Phase B-	Brake
2	Motor Phase B+	Motor Phase W
3	Motor Phase A-	Motor Phase V
4	Motor Phase A+	Motor Phase U
5	Motor Ground	
6	Logic 0VDC	
7	Logic +24VDC	
8	Ground	
9	Power 0VDC	
10	Power +48 to +80VDC	

RS232 Com-port D-SUB 9-pole X3	
Pin	Connection
1	-
2	Drive Clear (low activ)
3	Ground
4	Rx
5	Tx
6	-
7	Tx (D loop)
8	-
9	+ 5V Supply

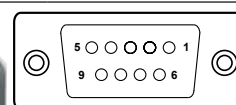
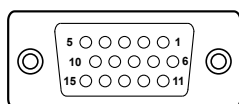

Resolver Feedback D-SUB 15-pole X2	
Pin	Connection
1	-
2	-
3	Ground
4	REF. res +
5	+ 5V supply
6	Motor -
7	- Sin
8	+ Sin
9	-
10	Motor +
11	- Cos
12	+ Cos
13	-
14	-
15	REF.res -

Digital Inputs and Outputs D-SUB 15-pole X5	
Pin	Connection
1	0 V
2	0 V
3	0 V
4	Output 2
5	Output 1
6	Input 5
7	Input 4
8	Input 3 (Homing)
9	Input 2
10	Input 1 (Start / Stop)
11	+ 24 V
12	+ 24 V
13	+ 24 V
14	Output 3
15	Analog Monitor



Stepper Motor

The 2-phase hybrid stepper motors were designed to suit most industrial applications that require special rigidity and reliability. The typical characteristic torque curve shows the maximum torque for the stepper motor, that must not be exceeded. For industrial applications motors usually are sized within the secure torque curve.

Technical Data - Stepper Motor

Characteristics	Symbol	Unit	SY563T	SY873T
Holding Torque	M_h	Nm	1.2	5.4
Nominal Speed	n_n	min^{-1}	900	900
Nominal Torque	M_n	Nm	0.8	2.5
Critical Speed	n_l	min^{-1}	1,800	1,800
Torque at Critical Speed	M_l	Nm	0.5	1.2
Current per Phase (parallel)	I_{ph}	A	6.5	8.4
Inductivity per Phase		mH	1.2	1.7
Inertia	J	kgcm^2	0.38	1.95
Weight	m	kg	1.4	3.7

Torque Curve SY563T

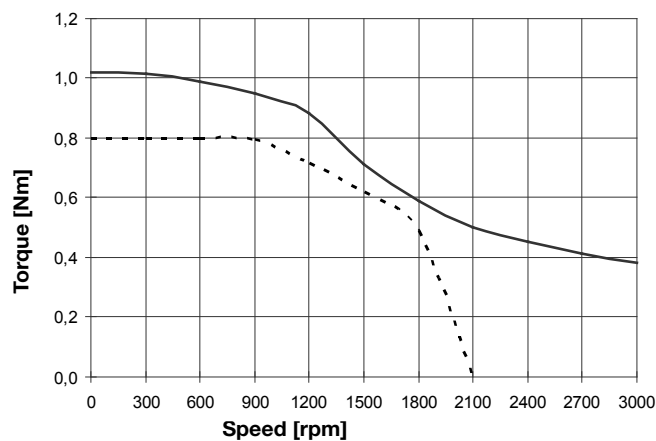

— characteristic torque curve
 - - - secure torque curve

Torque Curve SY873T

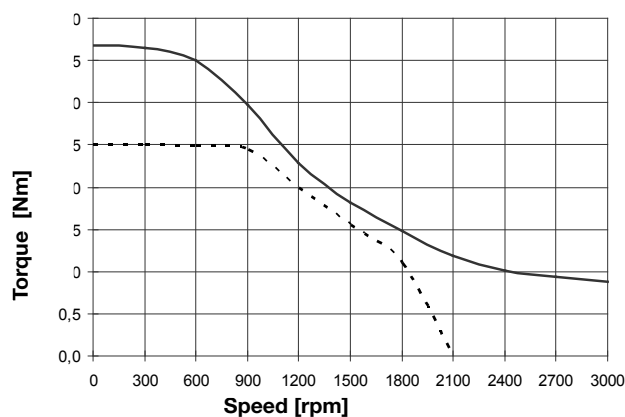

P-A4P017GB

OSP-E

EasyDrive Stepper Motor - Series SY563T, SY873T

Dimensions

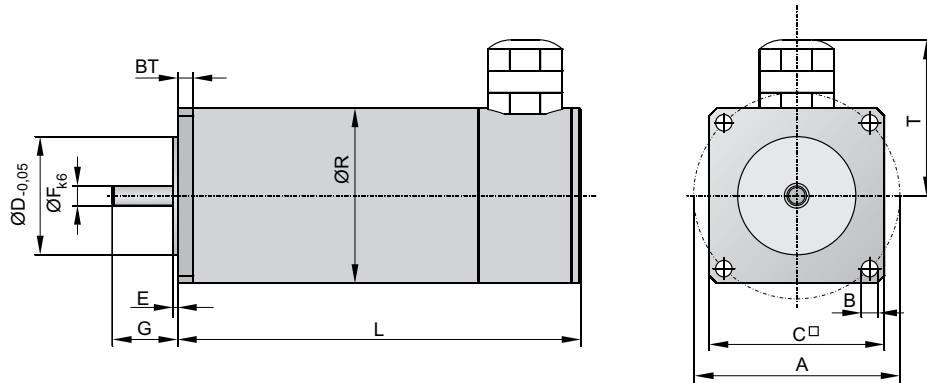

DC Steppermotor SY

Dimension Table [mm]

Type	ø A	ø B	BT	□ C	ø D	E	ø F	G	L	R
SY563T	66.5	5.3	5	56.5	38.1	2.5	6.35	21.0	130.0	56.5
SY873T	99.0	6.5	6	86.0	73.0	3.0	9.52	31.5	149.5	86.0



Servo Motor

The dynamic, brushless SMB servomotors show excellent power density. With their high quality Neodym magnets they give outstanding values for torque and dynamics while they have a very compact design.

Technical Data

Characteristics	Symbol	Unit	SMB60-30	SMB82-25
Motor				
Stand Still Torque	M_{ss}	Nm	1.4	3.0
Stand Still Current	I_{ss}	A	1.0	1.2
Nominal Speed	n_n	min^{-1}	3,000	2,500
Nominal Torque	M_n	Nm	1.0	1.5
Nominal Current	I_n	A	0.9	1.1
Peak Torque	M_p	N_m	3.0	4.5
Peak Current	I_p	A	2.7	3.3
Torque constant	K	Nm/A	0.90	0.73
Rotor Inertia	J	kgcm^2	0.3	1.4
Weight	m	kg	1.5	3.5
Holding Brake				
Holding Torque	M_{BR}	N_m	2.2	5.0
Supply Voltage	U_{BR}	VDC	24.0	24.0
Supply Current	I_{BR}	A	0.34	0.50
Inertia	J_{BR}	kgcm^2	0.13	0.43
Weight	m_{BR}	kg	0.3	0.7

The typical torque curve of a servo motor shown in the graphic beside. Shortly the nominal torque curve can be exceeded to at maximum the peak torque curve. The RMS torque of the application must not exceed the nominal torque value of the motor.

Torque curve SMB60

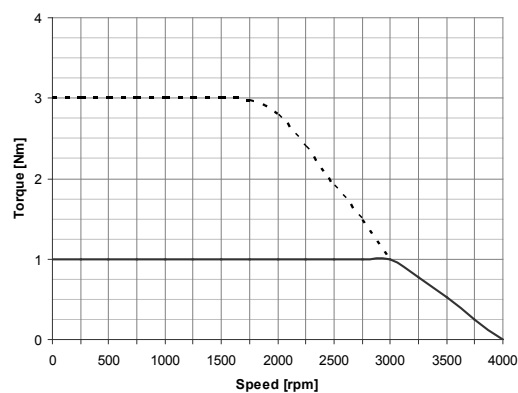

Torque curve SMB82

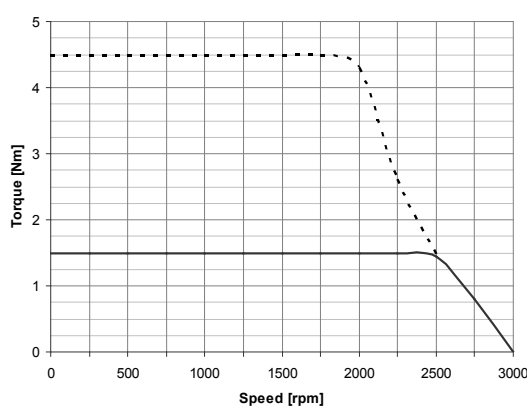

————— Nominal Torque Curve
 - - - - - Peak Torque Curve

P-A4P017GB

OSP-E

EasyDrive Servo Motor - Serie SMB 60, SMB82

Dimension

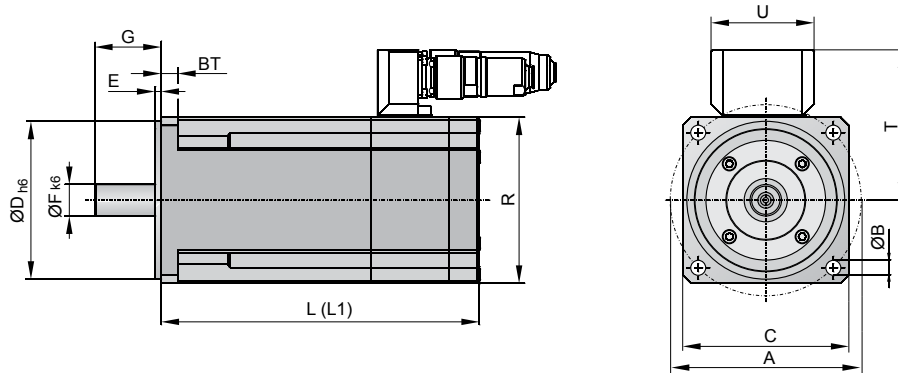

Dimension Table [mm]

Type	$\varnothing A$	$\varnothing B$	BT	$\square C$	$\varnothing D_{h6}$	E	$\varnothing F_{k6}$	G	L (without brake)	L1 (with brake)	R	T	U
SMx60	63	5.5	7	60	40	2.5	11	23	129.5	161.0	60	70	62
SMx82	100	6.5	10	82	80	3.5	14	30	163.5	206.5	82	81	62



P-A4P017GB

OSP-E

EasyDrive Stepper packages

Type of drive		Coupling Housing	Motor Coupling	Motor Flange		
OSP-E25B		20606FIL	10802FIL	12020FIL		
			18284FIL	15021FIL		
OSP-E32B		20607FIL	12164FIL	16083FIL		
			10842FIL	12022FIL		
OSP-E50B		20608FIL	10845FIL	16072FIL		
<hr/>						
OSP-E25S*		20137FIL	12071FIL	12058FIL		
OSP-E32S*			20138FIL	16004FIL		12181FIL
		OSP-E50S*		20139FIL		12164FIL
						10842FIL
				12079FIL		16072FIL

EasyDrive Servo packages

Type of drive		Coupling Housing	Motor Coupling	Motor Flange	
OSP-E25B		20606FIL	10803FIL	16060FIL	
OSP-E32B			20607FIL	12074FIL	
		OSP-E50B		20608FIL	
<hr/>					
Type of Drive		Coupling Housing	Motor Coupling	Motor Flange	
OSP-E25S*		20137FIL	12070FIL	16068FIL	
OSP-E32S*			20138FIL	12074FIL	
		OSP-E50S*		20139FIL	

* OSP-E, ..SB, ..ST, ..SBR, ..STR

** EasyDrive packages consisting of controller, motor and 5 m cable (motor/feedback)

Accessories

Description	Comment	Order No.
Power Supply	XLPSU 80VDC@3A / 24VDC@0,25A	18356FIL
I/O Connection Cable	D-SUB 15-pole flying leads, 5 m	18357FIL
Communication Cable	RS232 COM cable, 2 m	18358FIL



P-A4P017GB















OSP-E

<table border="1"> <tr> <td>EasyDrive Packages**</td> </tr> <tr> <td>18300FIL (EasyDrive Stepper SY563T)</td> </tr> <tr> <td>18301FIL (EasyDrive Stepper SY873T)</td> </tr> <tr> <td>18300FIL (EasyDrive Stepper SY563T)</td> </tr> <tr> <td>18301FIL (EasyDrive Stepper SY873T)</td> </tr> <tr> <td>18301FIL (EasyDrive Stepper SY873T)</td> </tr> </table>	EasyDrive Packages**	18300FIL (EasyDrive Stepper SY563T)	18301FIL (EasyDrive Stepper SY873T)	18300FIL (EasyDrive Stepper SY563T)	18301FIL (EasyDrive Stepper SY873T)	18301FIL (EasyDrive Stepper SY873T)	
EasyDrive Packages**							
18300FIL (EasyDrive Stepper SY563T)							
18301FIL (EasyDrive Stepper SY873T)							
18300FIL (EasyDrive Stepper SY563T)							
18301FIL (EasyDrive Stepper SY873T)							
18301FIL (EasyDrive Stepper SY873T)							
<table border="1"> <tr> <td>18300FIL (EasyDrive Stepper SY563T)</td> </tr> <tr> <td>18301FIL (EasyDrive Stepper SY873T)</td> </tr> <tr> <td>18300FIL (EasyDrive Stepper SY563T)</td> </tr> <tr> <td>18301FIL (EasyDrive Stepper SY873T)</td> </tr> <tr> <td>18301FIL (EasyDrive Stepper SY873T)</td> </tr> </table>	18300FIL (EasyDrive Stepper SY563T)	18301FIL (EasyDrive Stepper SY873T)	18300FIL (EasyDrive Stepper SY563T)	18301FIL (EasyDrive Stepper SY873T)	18301FIL (EasyDrive Stepper SY873T)		
18300FIL (EasyDrive Stepper SY563T)							
18301FIL (EasyDrive Stepper SY873T)							
18300FIL (EasyDrive Stepper SY563T)							
18301FIL (EasyDrive Stepper SY873T)							
18301FIL (EasyDrive Stepper SY873T)							

<table border="1"> <tr> <td>EasyDrive Packages**</td> </tr> <tr> <td>18302FIL (EasyDrive Servo SMB60)</td> </tr> <tr> <td>18312FIL (EasyDrive Servo SMBA60)</td> </tr> <tr> <td>18302FIL (EasyDrive Servo SMB60)</td> </tr> <tr> <td>18312FIL (EasyDrive Servo SMBA60)</td> </tr> <tr> <td>18303FIL (EasyDrive Servo SMB82)</td> </tr> <tr> <td>18304FIL (EasyDrive Servo SMBA82)</td> </tr> <tr> <td>18303FIL (EasyDrive Servo SMB82)</td> </tr> <tr> <td>18304FIL (EasyDrive Servo SMBA82)</td> </tr> </table>	EasyDrive Packages**	18302FIL (EasyDrive Servo SMB60)	18312FIL (EasyDrive Servo SMBA60)	18302FIL (EasyDrive Servo SMB60)	18312FIL (EasyDrive Servo SMBA60)	18303FIL (EasyDrive Servo SMB82)	18304FIL (EasyDrive Servo SMBA82)	18303FIL (EasyDrive Servo SMB82)	18304FIL (EasyDrive Servo SMBA82)	
EasyDrive Packages**										
18302FIL (EasyDrive Servo SMB60)										
18312FIL (EasyDrive Servo SMBA60)										
18302FIL (EasyDrive Servo SMB60)										
18312FIL (EasyDrive Servo SMBA60)										
18303FIL (EasyDrive Servo SMB82)										
18304FIL (EasyDrive Servo SMBA82)										
18303FIL (EasyDrive Servo SMB82)										
18304FIL (EasyDrive Servo SMBA82)										
<table border="1"> <tr> <td>EasyDrive Packages</td> </tr> <tr> <td>18302FIL (EasyDrive Servo SMB60)</td> </tr> <tr> <td>18312FIL (EasyDrive Servo SMBA60)</td> </tr> <tr> <td>18302FIL (EasyDrive Servo SMB60)</td> </tr> <tr> <td>18312FIL (EasyDrive Servo SMBA60)</td> </tr> <tr> <td>18303FIL (EasyDrive Servo SMB82)</td> </tr> <tr> <td>18304FIL (EasyDrive Servo SMBA82)</td> </tr> <tr> <td>18303FIL (EasyDrive Servo SMB82)</td> </tr> <tr> <td>18304FIL (EasyDrive Servo SMBA82)</td> </tr> </table>	EasyDrive Packages	18302FIL (EasyDrive Servo SMB60)	18312FIL (EasyDrive Servo SMBA60)	18302FIL (EasyDrive Servo SMB60)	18312FIL (EasyDrive Servo SMBA60)	18303FIL (EasyDrive Servo SMB82)	18304FIL (EasyDrive Servo SMBA82)	18303FIL (EasyDrive Servo SMB82)	18304FIL (EasyDrive Servo SMBA82)	
EasyDrive Packages										
18302FIL (EasyDrive Servo SMB60)										
18312FIL (EasyDrive Servo SMBA60)										
18302FIL (EasyDrive Servo SMB60)										
18312FIL (EasyDrive Servo SMBA60)										
18303FIL (EasyDrive Servo SMB82)										
18304FIL (EasyDrive Servo SMBA82)										
18303FIL (EasyDrive Servo SMB82)										
18304FIL (EasyDrive Servo SMBA82)										

P-A4P017GB

OSP-E

Description	Illustration		Page
Motor Mountings		Coupling Housing, Motor Flange, Motor Coupling	133 ff
		Belt Gear	
End Cap Mountings			141 ff
		Flange C-E	
Profile Mountings		Mid Section Support Guide Mounting	147 ff
		Adapter Profile	
		Trunnion and Pivot Mounting	
Compensations		Clevis Mounting	155 ff
		Inversion Mounting	
		Piston Rod Eye, Piston Rod Clevis, Piston Rod Compensating Coupling	
Guide Mountings		End Cap Mounting Profile Mounting	161 ff
Magnetic Sensors			165 ff
Displacement Measuring System SFI-plus			171 ff
Cable Cover			175 ff

P-A4P017GB

OSP-E

Motor Mountings

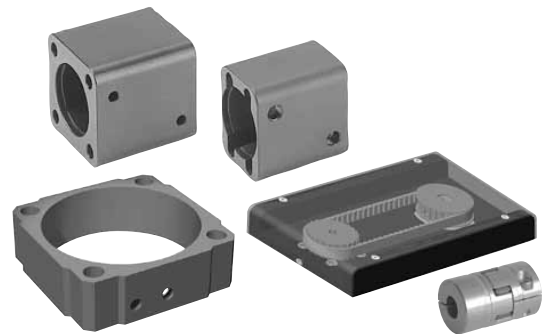

Content

Description	Page
Coupling Housing, Motor Flanges (OSP-E..BHD)	134
Coupling Housing, Motor Flanges, Motor Coupling (OSP-E..BV)	135
Coupling Housing, Motor Flanges, Motor Coupling (OSP-E..B)	136
Coupling Housing, Motor Flanges, Motor Coupling (OSP-E ..SB, ..ST, ..SBR, ..STR)	137
Motor Flanges for Freely Selectable Mounting Dimensions (OSP-E..B, ..SB, ..ST, ..SBR, ..STR)	138
Belt Gear for freely Selectable Mounting Dimensions (OSP-E..SB, ..ST, ..SBR, ..STR)	140

P-A4P017GB

OSP-E

Coupling Housing Motor Flange - Size 20, 25, 32, 50

• OSP-E..BHD Belt Actuator with Integrated Guide

Via the coupling housing the gear or the motor can be fitted directly to the actuator and the drive shafts by means of a motor flange.



The motor flange matches the above mentioned coupling housing and has been reworked to match the respective type of motor.

Motor flanges for the available range of gears, servo and stepper motors are included in the respective data sheet, including technical data and dimensions. Please refer to the respective catalogues.

Coupling Housing (for gear or motor mounting)

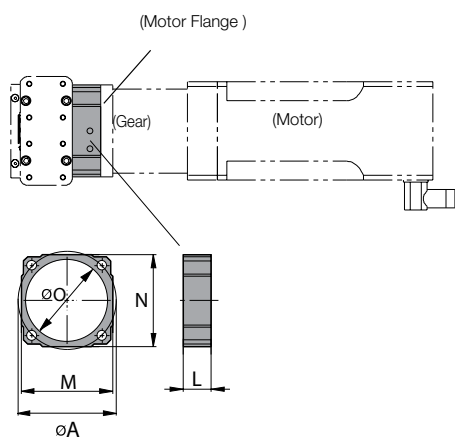

Coupling Housing (for gear or motor mounting)

Series	Ø A	L	M	N	Ø O	Order No.
OSP-E20BHD	65.8	19	60	60	48	16215FIL
OSP-E20BHD*	65.8	79	60	60	48	16269FIL
OSP-E25BHD	82.0	22	76	76	68	12300FIL
OSP-E32BHD	106.0	30	98	98	88	12301FIL
OSP-E50BHD	144.0	41	130	130	118	12302FIL

* Coupling housing for gear or motor mounting with a motor coupling

Motor Flange (semi-finished)

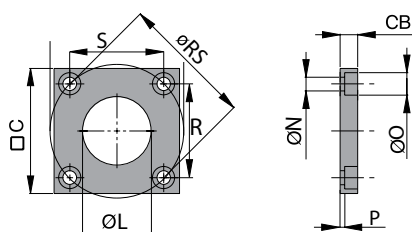

Motor Flange (semi-finished)

Series	□ C	CB	Ø L	Ø N	Ø O	P	R	S	Ø RS	Order No.
OSP-E20BHD	75	10	25	6.6	11	3.2	46.5	46.5	65.8	16216FIL
OSP-E25BHD	90	14	36	9.0	15	5.5	57.9	57.9	82.0	12308FIL
OSP-E32BHD	100	14	55	11.0	18	3.5	74.9	74.9	106.0	12309FIL
OSP-E50BHD	125	18	77	13.5	20	5.5	101.8	101.8	144.0	12310FIL

Motor Flange (finished)

Series	Comment	Order No. *
OSP-E20BHD	for PV40-TA / LP050	16224FIL
OSP-E20BHD	for PV60-TA / LP070 (with gear mounting 15166)	16273FIL
OSP-E20BHD	for PS60	18283FIL
OSP-E25BHD	for PV60-TA / LP070	12311FIL
OSP-E25BHD	for PS60	18413FIL
OSP-E32BHD	for PV90-TA / LP090	12312FIL
OSP-E32BHD	for PS90	18419FIL
OSP-E50BHD	for PV115-TA / LP120	12313FIL
OSP-E50BHD	for PS115	18422FIL

*Motor Coupling not included

P-A4P017GB

OSP-E

Coupling Housing / Motor Flange / Motor Coupling - Size 25

• OSP-E..BV Vertical Belt Actuator with Integrated Ball Bearing Guide

The coupling housing with suitable motor flange allows proper connection between the drive shaft of the actuator and the gear shaft or motor shaft. The gear or motor can either be fitted to the actuator directly or indirectly. If a Parker Origa gear is used, direct clamping of the gear shaft into to the drive shaft with clamping Stroke. As an alternative the gear or motor can be fitted to the actuator via a motor coupling.

1) **Hint:** when selecting the type of motor mounting please observe the respective drive shaft versions in accordance with the ordering code of the actuator (page 36).

Coupling Housing

for Direct Clamping

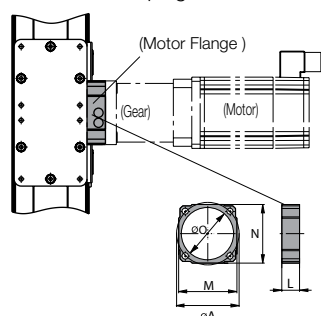

for Clamping with Motor Clamping

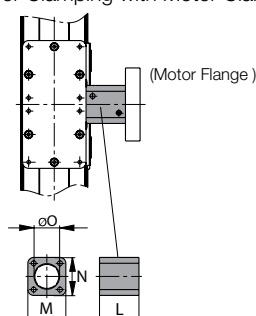

Series	Ø A	L	M	N	Ø O	Order No.
OSP-E20BV	65.8	19	60	60	48	16215FIL
OSP-E20BV*	65.8	79	60	60	48	16269FIL
OSP-E25BV	82.0	22	76	76	68	12300FIL
OSP-E25BV*	65.8	84	87	87	48	20139FIL

* Coupling housing for gear or motor mounting with a motor coupling

Universal Motor Coupling

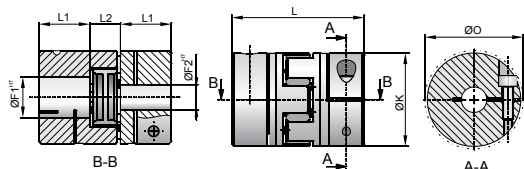

Series	Ø F ₁ ^{H7}	Ø F ₂ ^{H7}	Ø F ^{H7}	Ø K	L	L ₁	L ₂	Ø O	Order No.
OSP-E20BV	12	9.5	8 - 24	40	66	25	16	46	16268FIL
OSP-E25BV	16	9.5	8 - 24	40	66	25	16	46	10845FIL

Motor Flange

(semi-finished)

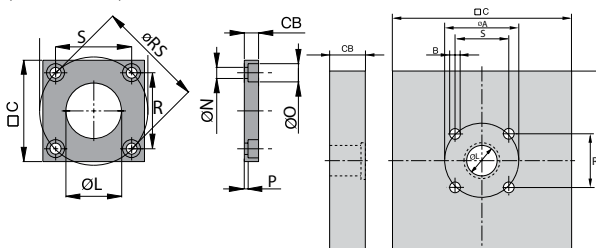

universal

Series	□ C	CB	Ø L	Ø N	Ø O	P	R	S	Ø RS	Order No.
OSP-E20BV	75	10	25	6.6	11	3.2	46.5	46.5	65.8	16216FIL
OSP-E20BV*	120	15	25	6.6	11	3.0	46.5	46.5	65.8	16267FIL
OSP-E25BV	90	14	36	9.0	15	5.5	58.0	58.0	82.0	12308FIL
OSP-E25BV*	120	15	35	6.6	11	3.0	46.0	46.0	65.0	12069FIL

Motor Flange (finished)

Series	Comment	Order No.
OSP-E20BV	for PV40-TA / LP050 (for Standard Clamp Shaft)	16224FIL
OSP-E20BV	for PV60-TA / LP070 (for Plain Shaft)	16273FIL
OSP-E20BV	for PS60 (for Plain Shaft)	18283FIL
OSP-E25BV	for PV60-TA / LP070	12311FIL
OSP-E25BV	for PS60	18413FIL



P-A4P017GB

OSP-E

Coupling Housing / Motor Flange / Motor Coupling - Size 25, 32, 50

• OSP-E..B Belt Actuator with Internal Plain Bearing Guide

The coupling housing with suitable motor flange allows easy and inherently stable connection of the gear or the motor to the actuator.

Hint: Let us know the mounting dimensions of your motor. Upon request we will be pleased to check and manufacture a motor flange that will come up to your individual needs. (Also see "motor flange for freely selectable mounting dimensions" page 126 ff)

Coupling Housing (for gear or motor mounting)

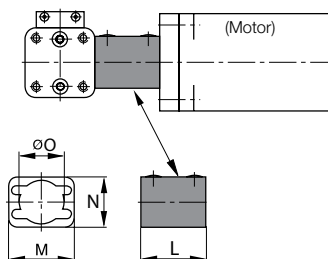

Series	Ø A	L	M	N	Ø O	Order No.
OSP-E25B	33.5	47	40	30	25	20606FIL
OSP-E32B	42.0	49	49	38	33	20607FIL
OSP-E50B	59.4	76	65	54	48	20608FIL

Motor Coupling Dimension [mm] and Order No.

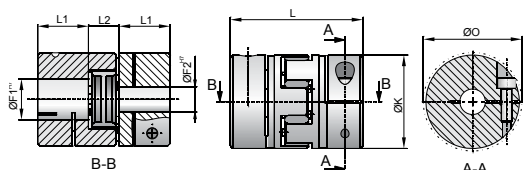

Series	Ø F ₁ H7	Ø F ₂ H7	Ø FH7	Ø K	L	L1	L2	Ø O	Order No.
OSP-E25B	10	4.0	4 - 11	20	30	10	10	23.4	12073FIL
OSP-E32B	10	6.0	5 - 16	30	35	11	13	32.2	15197FIL
OSP-E50B	16	9.5	8 - 24	40	66	25	16	46.0	10845FIL

Motor Flange (universal)

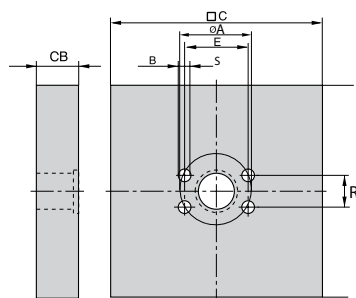

Series	□ C	CB	Ø L	Ø N	Ø O	P	R	S	Ø RS	Order No.
OSP-E25B	100	20	16	5.5	10	3.0	30.0	15.0	33.5	12050FIL
OSP-E32B	100	20	22	6.6	11	4.0	38.0	18.0	42.0	12053FIL
OSP-E50B	120	15	35	9.0	15	3.0	50.0	32.0	59.4	12056FIL

Motor Flange (finished)

Series	Comment	Order No. *
OSP-E25B	for PV40-TA / LP050 (Motor Coupling12080)	16076FIL
OSP-E32B	for PV40-TA / LP050 (Motor Coupling10841)	16090FIL
OSP-E32B	for PV60-TA / LP070 (Motor Coupling12980)	15930FIL
OSP-E32B	for PS60 (Motor Coupling12980)	18272FIL
OSP-E50B	for PV60-TA / LP070 (Motor Coupling12981)	16057FIL
OSP-E50B	for PS60 (Motor Coupling12981)	18277FIL

*Motor coupling not included

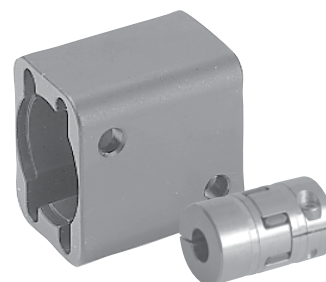

Parker Hannifin Corporation
Pneumatic Division - Europe

P-A4P017GB

OSP-E

Coupling Housing / Motor Flange / Motor Coupling - Size 25, 32, 50

- **OSP-E..SB, ..ST Screw Actuator with Internal Plain Bearing Guide**
- **OSP-E..SBR, ..STR Screw Actuator with Internal Plain Bearing Guide and Piston Rod**

The coupling housing with suitable motor flange allows easy and inherently stable connection of the gear or the motor to the actuator.

Hint: Let us know the mounting dimensions of your motor. Upon request we will be pleased to check and manufacture a motor flange that will come up to your individual needs. (Also see "configurable motor flange" page 128)

Coupling Housing (for Motor)

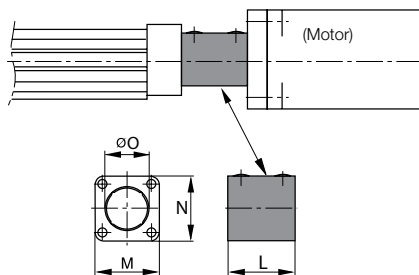

Series	Ø A	L	M	N	Ø O	Order No.
OSP-E25S...	38.2	38	41	41	25	20137FIL
OSP-E32S...	50.9	54	52	52	33	20138FIL
OSP-E50S...	65.0	84	87	87	48	20139FIL

Motor Coupling Dimension [mm] and Order No.

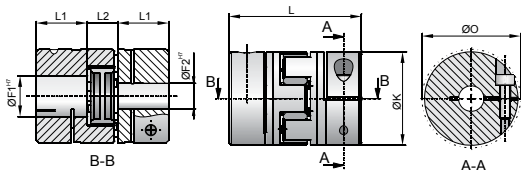

Series	Ø F ₁ ^{H7}	Ø F ₂ ^{H7}	Ø FH ⁷	Ø K	L	L1	L2	Ø O	Order No.
OSP-E25S...	6	6.0	4 - 11	20	30	10	10	23.4	12073FIL
OSP-E32S...	10	6.0	5 - 16	30	35	11	13	32.2	15197FIL
OSP-E50S...	15	9.5	8 - 24	40	66	25	16	46.0	12079FIL

Motor Flange (universal)

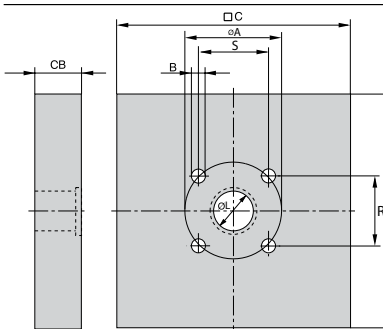

Series	□ C	CB	Ø L	Ø N	Ø O	P	R	S	Ø RS	Order No.
OSP-E25S...	100	20	16	5.5	10	3.0	27.0	27.0	38.2	12060FIL
OSP-E32S...	100	20	22	6.6	11	4.0	36.0	36.0	50.9	12064FIL
OSP-E50S...	120	15	35	6.6	11	3.0	46.0	46.0	65.0	12069FIL

Motor Flange (finished)

Series	Comment	Order No. *
OSP-E25S...	for PV40-TA / LP050 (Motor Coupling12072)	16058FIL
OSP-E32S...	for PV40-TA / LP050 (Motor Coupling10841)	16070FIL
OSP-E32S...	for PV60-TA / LP070 (Motor Coupling12980)	15803FIL
OSP-E32S...	for PS60 (with Motor Coupling12980)	18281FIL
OSP-E50S...	for PV60-TA / LP070 (Motor Coupling15227)	15526FIL
OSP-E50S...	for PS60 (with Motor Coupling15227)	18283FIL

*Motor coupling not included

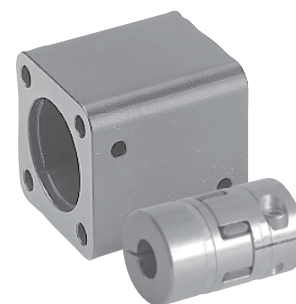

P-A4P017GB

OSP-E

Motor Flange for Freely Selectable Mounting Dimensions
- Size 25, 32, 50

- **OSP-E..B Ball Actuator with Internal Plain Bearing Guide**
- **OSP-E..SB, .. ST - Screw Actuator with Internal Plain Bearing Guide**
- **OSP-E..SBR, STR - Screw Actuator with Internal Plain Bearing Guide and Piston Rod**

The motor flange for motors with freely selectable mounting dimensions offers flexible possibilities to connect most different types of motors to the electric actuators OSP-E. The drive shafts of actuator and motor are connected with a motor coupling in the coupling housing and the motor flange is centred.

Hint: Please check the following data for the connection of the motor to the freely selectable motor flange and state when ordering:

1. mounting angle W of the motor
2. bore hole version B as thread M or counterbore S
3. pitch circle diameter A as a function of M or S
4. Diameter of centring spigot D
5. Length of motor shaft G

Variable Dimensions for Flange

Version Thread „M“
 Flange plate with thread,
 Motor flange with through bolt

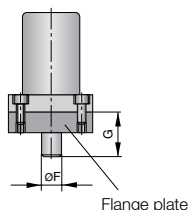

Version Counterbore „S“
 Flange plate with through bore
 Motor flange with thread

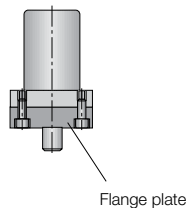

Version Counterbore „S“

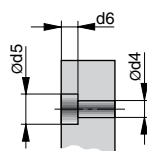

Version Thread „M“

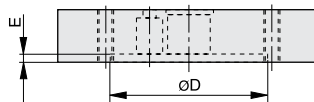
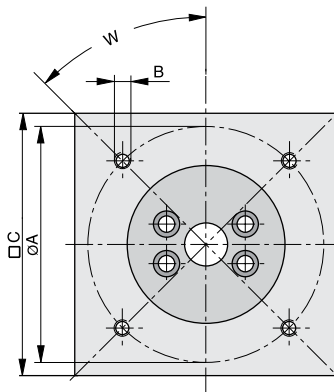
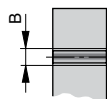

Counterbore Dimensions [mm]

Screw Size	Ød4	Ød5	d6
M4x16	4.5	8.0	4.6
M5x22	5.5	10.0	5.7
M6x20	6.6	11.0	6.8
M8x25	9.0	15.0	9.0
M10x25	11.0	18.0	11



P-A4P017GB

OSP-E

Dimension [mm] – Version for Belt Drive

W	45 °			90 °			
Size	25	32	50	25	32	50	
A	min. Vers. S	48 + Ød5	60 + Ød5	80 + Ød5	40 + Ød5	49 + Ød5	65 + Ød5
	max. Vers. S	135 - Ød5	135 - Ød5	160 - Ød5	100 - Ød5	100 - Ød5	120 - Ød5
	min. Vers. M	45 + B	55 + B	75 + B	40 + B	48 + B	50 + B
	max. Vers. M	135 - B	135 - B	160 - B	96 - B	96 - B	116 - B
B max.	M10			M10			
D	min.	20	30	40	20	30	40
	max.	98	98	118	85	85	105
G	min.	18	21	32	18	21	32
	max.	33	35	45	33	35	45
C	100	100	120	100	100	120	

Dimension Table of the Variable Dimension [mm] – Version for Screw Drive

W	45 °			90 °			
Size	25	32	50	25	32	50	
A	min. Vers. S	58 + Ød5	74 + Ød5	123 + Ød5	41 + Ød5	52 + Ød5	87 + Ød5
	max. Vers. S	135 - Ød5	135 - Ød5	160 - Ød5	100 - Ød5	100 - Ød5	120 - Ød5
	min. Vers. M	52 + B	68 + B	82 + B	30 + B	40 + B	50 + B
	max. Vers. M	135 - B	135 - B	160 - B	96 - B	96 - B	116 - B
B max.	M10			M10			
D	min.	20	30	40	20	30	40
	max.	98	98	118	85	85	105
G	min.	18	21	32	18	21	32
	max.	33	35	45	33	35	45
C	100	100	120	100	100	120	

Legend

- W [°] = Angle of fastening boreholes
- A [mm] = Pitch circle diameter
- B = Thread size of fastening screw (version: M = thread, S = counterbore)
- D [mm] = Diameter of centring spigot
- E [mm] = Depth of centring spigot
- F [mm] = Diameter of motor shaft
- G [mm] = Length of motor shaft

Order Instructions

Description	Ident-Nr.
Article is configurable customized	18184FIL



P-A4P017GB

OSP-E

Belt Gear for Freely Selectable Mounting Dimensions - Size 25, 32, 50

• Series OSP-E..SB, ..ST, ..SBR, ..STR Actuator with Screw

The belt gear with its freely selectable mounting dimensions offers the possibility to fit most different Types of motors to the actuator parallel to the motor axis. After the flange dimensions of the motor had been checked, the mounting side of the motor will be prepared for the individual demands of the customer.

When ordering please observe the version of the drive shaft of the actuator OSP-E with spindle. This version can either be ordered with plain shaft or plain shaft with keyway (Option). (If the version keyway is selected, the delivery period may be elongated.)

Versions of Drive Shaft OSP-E with Screw

Order No.	Drive Shaft
OSP-E..*... ..0-.....	Plain
OSP-E..*... ..3-.....	Keyway
OSP-E..*... ..4-.....	Keyway long

*1=SB, 2=ST, 3=STR, 4=SBR

Max. Allowed Moment M [Nm] for Belt Gear

Size	Transmission	
	1:1	2:1
25	5	5
32	10	10
50	20	20

Beware of the max. allowed moments of the corresponding actuator

Belt Gear

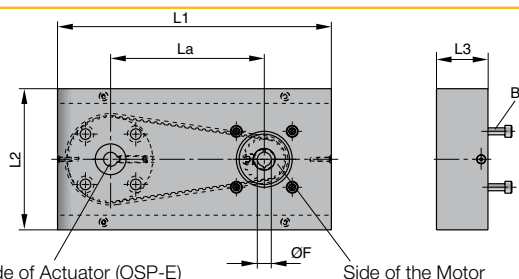

Side of Actuator (OSP-E)

Side of the Motor

Dimension [mm] and Order Instructions

Series	L1	L2	L3		La	B	ØF*	Order No.
			1:1	2:1				
OSP-E25	186	101	30	110	109,3		6, 7, 8, 9, 10, 11	15576FIL
OSP-E32	196	101	37	110	111,4	M4 - M10	8, 9, 10, 11, 12, 14	15576FIL
OSP-E50	234	101	50	135	133,7		12, 14, 16, 19	15576FIL

* other diameters on request

Variable Dimensions for Motor Mounting

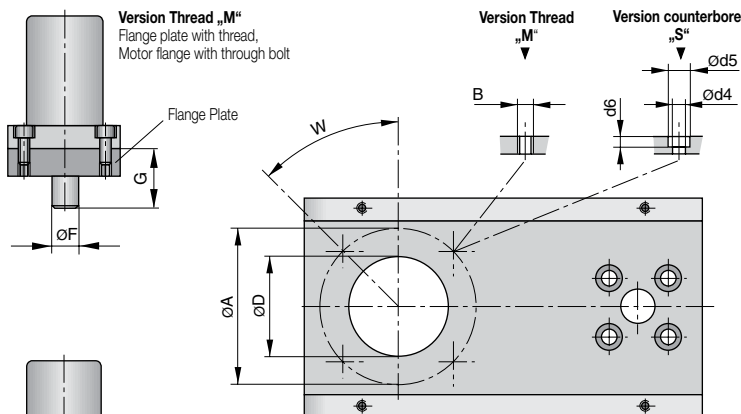

Screw Size	Ø d4	Ø d5	d6
M4	4.5	8	4.5
M5	5.5	10	5.3
M6	6.6	11	6.3
M8	9.0	15	5.5
M10	11	18	6.7

Dimension Table of the Variable Dimensions [mm]

W	45 °			90 °			
	Size	25	32	50	25	32	50
A	min.	30			30		
	max. Vers. S	110 - Ød5			70 - Ød5	70 - Ød5	80 - Ød5
	max. Vers. M	110 - Ød4			70 - Ød4	70 - Ød4	80 - Ød4
B	max.	M 8			M 8		
D	min.	20			20		
	max.	80	80	100	60	60	70
G	min.	16	20	30	16	20	30
	max.	23	30	40	23	30	40
ØF [mm]		6, 7, 8, 9, 10, 11	8, 9, 10, 11, 12, 14	12, 14, 16, 19	6, 7, 8, 9, 10, 11	8, 9, 10, 11, 12, 14	12, 14, 16, 19



P-A4P017GB

OSP-E

End Cap Mounting



Content

Description	Page
End Cap Mounting (OSP-E..BHD)	142
End Cap Mounting (OSP-E..SBR, ..STR)	144
Flange Mounting C-E (OSP-E..SBR, ..STR)	146

P-A4P017GB

OSP-E

End Cap Mounting - Size 20, 25, 32, 50

• **Series OSP-E..BHD for Actuator with Belt and Integrated Guides**

On the end-face of each end cap there are eight threaded holes for mounting the actuator.

Material: Anodized Aluminium

The mountings are supplied in pairs.

Series OSP-E20BHD to E32BHD: Type CN-20, CN-25, CN-32

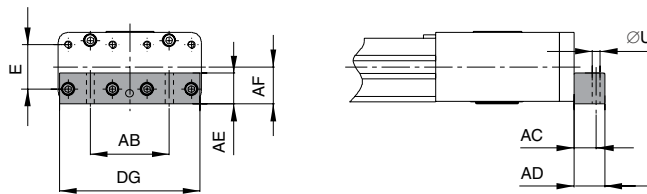

Series OSP-E50BHD: Type CN-50M

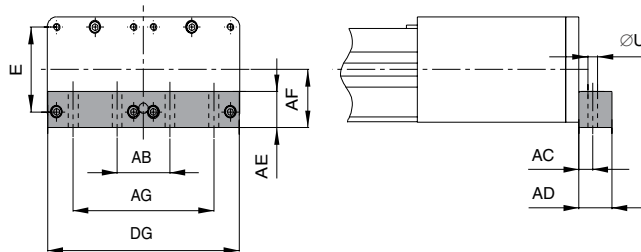

Dimension [mm] and Order Instructions

Series	Type	E	ØU	AB	AC	AD	AE	AF	AG	DG	Order No. *
OSP-E20BHD	CN-20	27	6.6	40	10.0	20	20	22	-	74	16213FIL
OSP-E25BHD	CN-25	27	6.6	52	16.0	25	25	22	-	91	12266FIL
OSP-E32BHD	CN-32	36	9.0	64	18.0	25	25	30	-	114	12267FIL
OSP-E50BHD	CN-50	70	9.0	48	12.5	30	30	48	128	174	12268FIL

(*=Pair)

P-A4P017GB

OSP-E

End Cap Mounting - Size 20, 25, 32, 50

• **Series OSP-E..BHD Actuator with Belt and Integrated Guide**

On the end-face of each end cap there are eight threaded holes each for mounting the actuator.

Material: Anodized Aluminium.

The mountings are supplied in pairs.

**Series OSP-E20BHD to E32BHD:
Type CO-20, CO-25, CO-32**

**Series OSP-E50BHD:
Type CO-50**

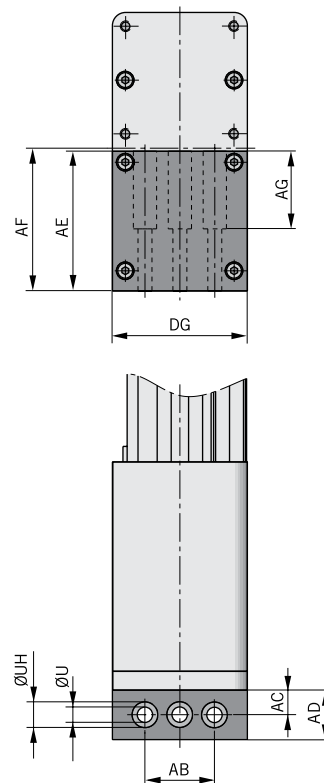
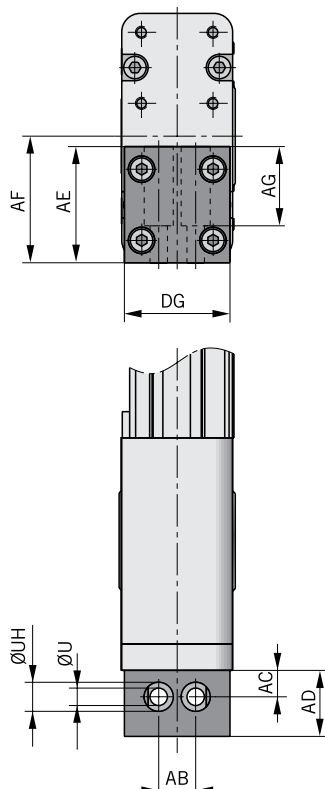

Dimension Table [mm] and Order Instructions

Series	Type	ØU	AB	AC	AD	AE	AF	AG	ØUH	DG	Order No. (*
OSP-E20BHD	CO-20	6.6	18	15	22	42	45	39	11	40	16241FIL
OSP-E25BHD	CO-25	6.6	14	10	25	44	48	30	11	40	16245FIL
OSP-E32BHD	CO-32	9.0	19	12	28	60	62	42	15	56	16246FIL
OSP-E50BHD	CO-50	9.0	45	16	32	90	92	50	15	87	16247FIL

(* = Pair)

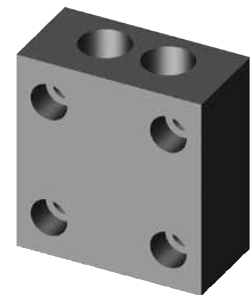

P-A4P017GB

OSP-E

End Cap Mounting - Size 25, 32, 50

- Series OSP-E...B Belt Actuator with Internal Plain Bearing Guide
- Series OSP-E..SB, .. ST Screw Actuator with Internal Plain Bearing Guide

On the end-face of each end cap there are four threaded holes for mounting the actuator. The hole layout is square, so that the mounting can be fitted to the bottom, top or either side.

Material: Series OSP-25 to 32: Galvanised steel.

Series OSP-50: Anodized Aluminium.

The mountings are supplied as pairs

Series OSP-E25 to E32: Type A1

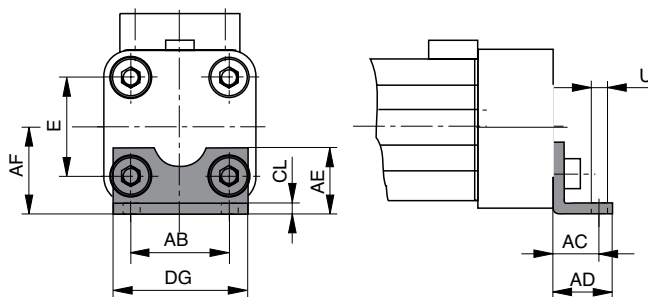

Series OSP-E50: Type C1

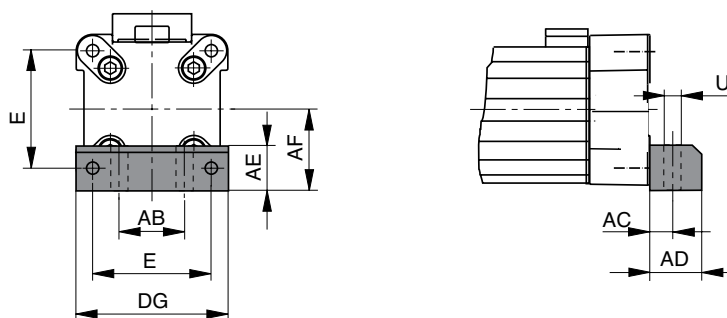

Dimension Table [mm] and Order Instructions

Series	E	ØU	AB	AC	AD	AE	AF	CL	DG	Order No. (*	
										Type A1	Type C1
OSP-E25	27	5.8	27	16.0	22	18	22	2.5	39	2010FIL	-
OSP-E32	36	6.6	36	18.0	26	20	30	3.0	50	3010FIL	-
OSP-E50	70	9.0	40	12.5	24	30	48	-	86	-	5010FIL

(* = Pair)



Important:

With the OSP-E Screw series, the end cap mounting can only be used at the end opposite to the drive shaft. We recommend the application of two mid section supports (page 136 ff) at the drive shaft end of the actuator.



P-A4P017GB

OSP-E

End Cap Mounting - Size 25, 32, 50

• **OSP-E..SBR, ..STR Actuator with Screw and Extending Rod**

On the end-face of each end cap there are four threaded holes for mounting the actuator. The hole layout is square, so that the mounting can be fitted to the bottom, top or either side.

Material: Series OSP-25 to 32: Galvanised steel.

Series OSP-50: Anodized Aluminium.

The mountings are supplied as pairs

Series OSP-E25SBR, 25STR to E32 SBR, 32STR: Type A1SR

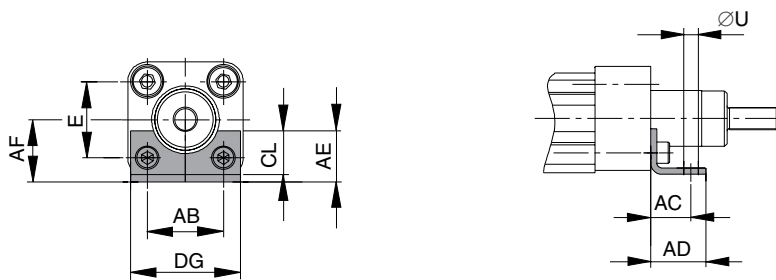

Series OSP-E50SBR, 50STR: Type C1SR

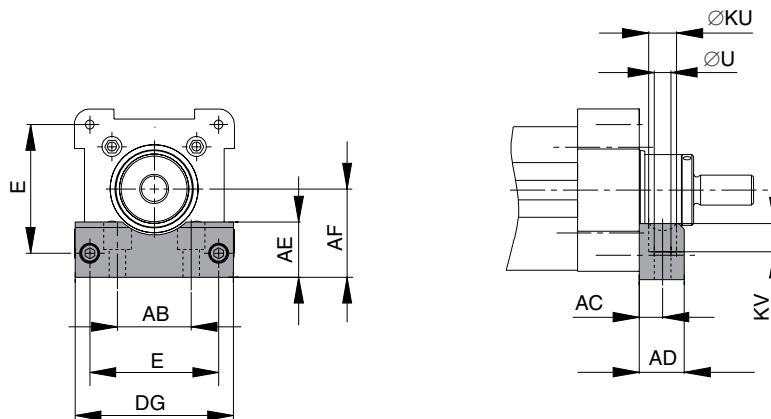

Dimension [mm] and Order Instructions

Series	E	ØU	AB	AC	AD	AE	AF	CL	DG	øKU	KV	Order No. (* Type A1SR C1SR)	Type
OSP-E25SBR, STR	27	5.8	27	16.0	22	18	22	2.5	39	-	-	12263FIL	-
OSP-E32SBR, STR	36	6.6	36	18.0	26	20	30	3.0	50	-	-	12264FIL	-
OSP-E50SBR, STR	70	9.0	40	12.5	24	30	48	-	86	15	15	-	12265FIL

(* = Single)

Important:

With the OSP-E Screw series, the end cap mounting can only be used at the end opposite to the drive shaft. We recommend the application of two mid section supports (page 136 ff) at the drive shaft end of the actuator.



P-A4P017GB

OSP-E

Flange Mounting C-E - Size 25, 32, 50

• **Series OSP-E..SBR, ..STR Actuator with Screw and Piston Rod**

The flange mounting C-E can only be mounted at the piston rod end of the actuator.

Material: Aluminium

Series OSP-E25SBR, STR to E50SBR, STR: Type C-E..

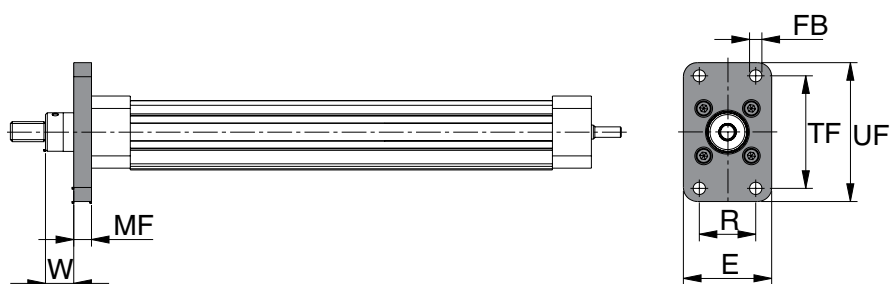

Dimension [mm] and Order Instructions

Series	Type	ØFB	E	MF	R	TF	UF	W	Order No.
OSP-E20SBR, STR	C-E25	7	50	10	32	64	79	16	12232FIL
OSP-E32SBR, STR	C-E32	9	56	10	36	72	90	16	12233FIL
OSP-E50SBR, STR	C-E50	12	100	16	63	126	153	21	12234FIL



P-A4P017GB

OSP-E

Profile Mounting



Content

Description	Page
Profile Mounting	148
Adaptor Profile	151
Connection Profile	153
Trunnion / Pivot Mounting EN/EL	154

P-A4P017GB

OSP-E

Profile Mounting - Size 20, 25, 32, 50

• **Series OSP-E**

Material: Anodized Aluminum

Stainless Steel Version on request.

The mountings are supplied in pairs.

Weight (mass) [kg]

Series	Weight (mass) [kg] (Pair)
MAE-20	0.3
MAE-25	0.3
MAE-32	0.4
MAE-50	0.8

Series OSP-E25 to E50, Type MAE-..

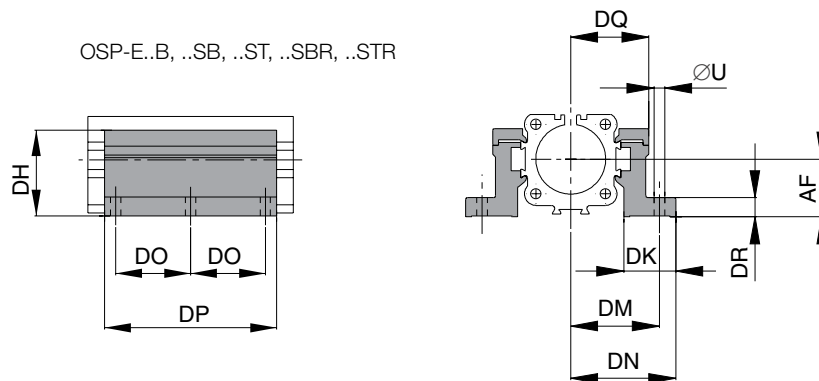

Series OSP-E20BHD to E50BHD, Type MAE-..

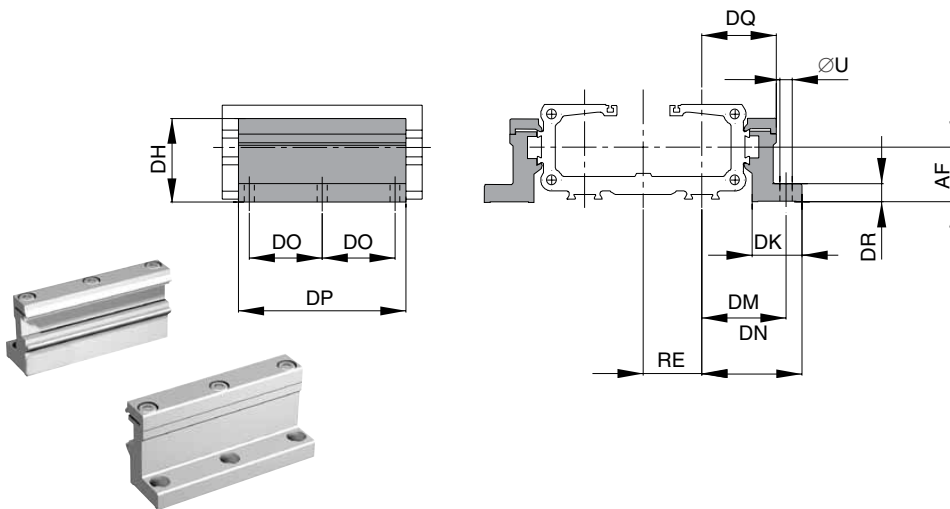

Dimension [mm] and Order Instructions

Series	Typ	R	U	AF	DF	DH	DK	DM	DN	DO	DP	DQ	DR	DT	EF	EM	EN	EQ	RE	Order No.
OSP-E20	MAE-20	M5	5.5	22	27	38	26	33.5	41.0	40	92	28.0	8	10	41.5	28.5	49	36	23	12278FIL
OSP-E25	MAE-25	M5	5.5	22	27	38	26	40.0	47.5	40	92	34.5	8	10	41.5	28.5	49	36	26	12278FIL
OSP-E32	MAE-32	M5	5.5	30	33	46	27	46.0	54.5	40	92	40.5	10	10	48.5	35.5	57	43	32	12279FIL
OSP-E50	MAE-50	M6	7.0	48	40	71	34	59.0	67.0	45	112	52.0	10	11	64.0	45.0	72	57	44	12280FIL



• **Series OSP-E ..BHD Belt Actuator with Integrated Guide**

Note on Types E1 and D1: The Profile Mounting can also be mounted on the underside of the actuator, in which case its distance from the centre of the actuator is different. For design notes, see page 14 ff. Stainless steel version on request.

The mountings are supplied singly.

Series OSP-E20BHD to E50BHD: Type E1 (Mountings with Through Holes)

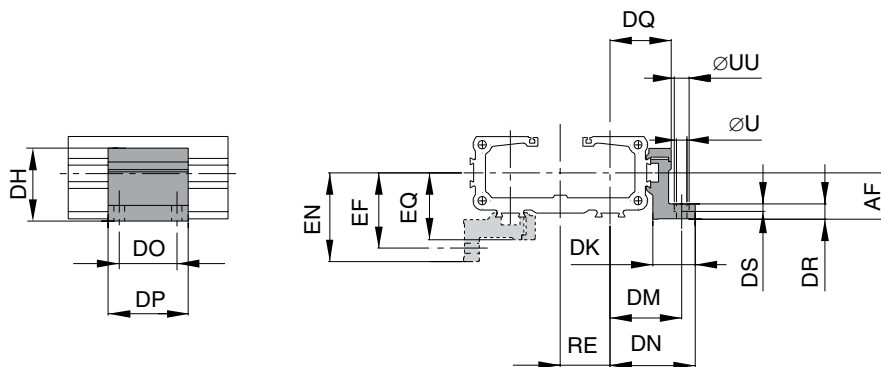

Series OSP-E20BHD to E50BHD: Type D1 (Mountings with Internal Thread)

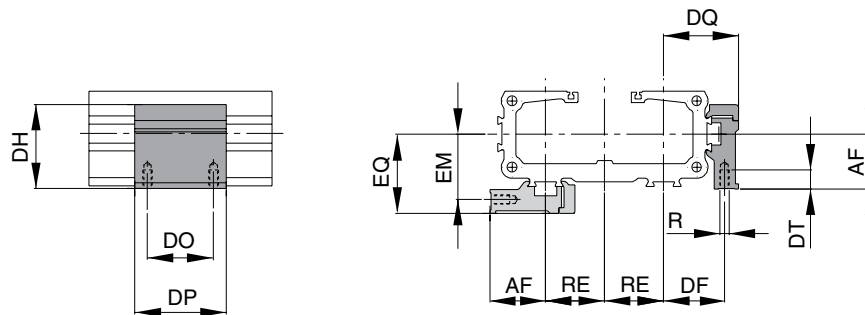

Dimension [mm] and Order Instructions

Series	R	U	UU	AF	DF	DH	DK	DM	DN	DO	DP	DQ	DR	DS	DT	EF	EM	EN	EQ	RE	Order No.	
																					Type E1	Type D1
OSP-E20	M5	5.5	10	22	20.5	38	26	33.5	41.0	36	50	28.0	8	5.7	10	41.1	28.1	48.6	35.6	23	20009FIL	20008FIL
OSP-E25	M5	5.5	10	22	27.0	38	26	40.0	47.5	36	50	34.5	8	5.7	10	41.5	28.5	49.0	36.0	26	20009FIL	20008FIL
OSP-E32	M5	5.5	10	30	33.0	46	27	46.0	54.5	36	50	40.5	10	5.7	10	48.5	35.5	57.0	43.0	32	20158FIL	20157FIL
OSP-E50	M6	7.0	-	48	40.0	71	34	59.0	67.0	45	60	52.0	10	-	11	64.0	45.0	72.0	57.0	44	15536FIL	15534FIL



P-A4P017GB

OSP-E

Profile Mounting - Size 25, 32, 50

- OSP-E..B Belt Actuator with Internal Plain Bearing Guide
- OSP-E..SB, ..ST Screw Actuator with Internal Plain Bearing Guide
- OSP-E..SBR, ..STR Screw Actuator with Internal Plain Bearing Guide and Piston Rod

Note on Types E1 and D1: The profile mounting can also be mounted on the underside of the actuator, in which case its distance from the centre of the actuator is different.

Stainless steel version on request.

Series OSP-E25, E32, E50, Type E1 (Mountings with Through Holes)

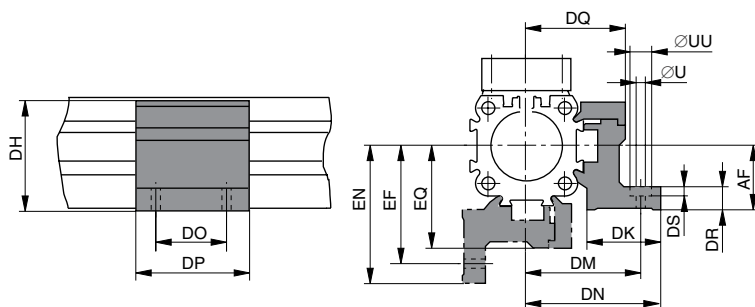

Series OSP-E25, E32, E50, Type D1 (Mountings with Internal Thread)

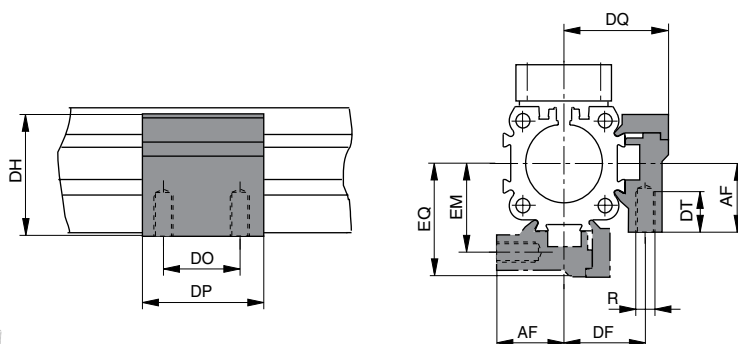

Dimension [mm] and Order Instructions

Series	R	U	UU	AF	DF	DH	DK	DM	DN	DO	DP	DQ	DR	DS	DT	EF	EM	EN	EQ	Order No.	
																				Type E1	Type D1
OSP-E25	M5	5.5	10	22	27	38	26	40	47.5	36	50	34.5	8	5.7	10	41.5	28.5	49	36	20009FIL	20008FIL
OSP-E32	M5	5.5	10	30	33	46	27	46	54.5	36	50	40.5	10	5.7	10	48.5	35.5	57	43	20158FIL	20157FIL
OSP-E50	M6	7.0	-	48	40	71	34	59	67.0	45	60	52.0	10	-	11	64.0	45.0	72	57	20163FIL	20162FIL



P-A4P017GB

OSP-E

Adaptor Profile -Size 25, 25, 32, 50

• OSP-E Adaptor Profile OSP

- A Universal Attachment for Mounting of Additional Items
- Solid Material

The mountings are supplied singly.

Series OSP-E25 to E50

OSP-E..B, ..SB, ..ST, ..SBR, ..STR

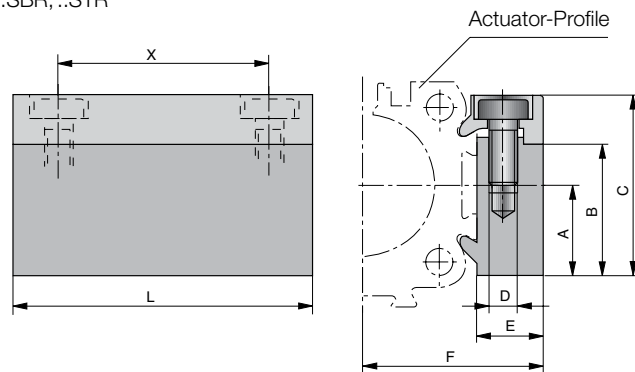

Series OSP-E20BHD to E50 BHD

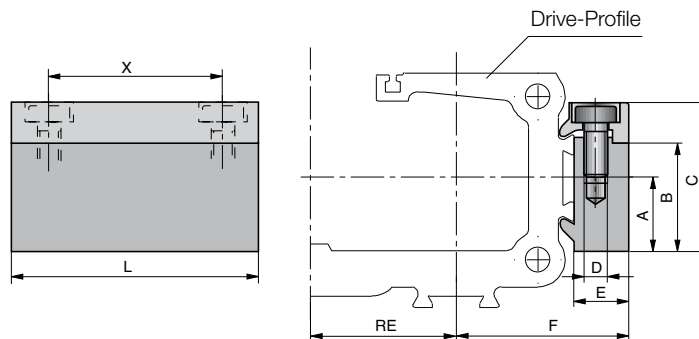

Dimension [mm] and Order Instructions

Series	A	B	C	D	E	F	L	X	RE	Order No.	
										Standard	Stainless
OSP-E20	16.0	23.0	32.0	M5	10.5	24.0	50.0	36.0	23.0	20006FIL	20186FIL
OSP-E25	16.0	23.0	32.0	M5	10.5	30.5	50.0	36.0	26.0	20006FIL	20186FIL
OSP-E32	16.0	23.0	32.0	M5	10.5	36.5	50.0	36.0	32.0	20006FIL	20186FIL
OSP-E50	20.0	33.0	43.0	M6	14.0	52.0	80.0	65.0	44.0	20025FIL	20267FIL



P-A4P017GB

OSP-E

Adaptor Profile T-slot - Size 20, 25, 32, 50

• **Series OSP-E T-Slot OSP**

A universal Attachment for Mounting with Standard T-nuts.

Series OSP-E25 to E50

OSP-E..B, ..SB, ..ST, ..SBR, ..STR

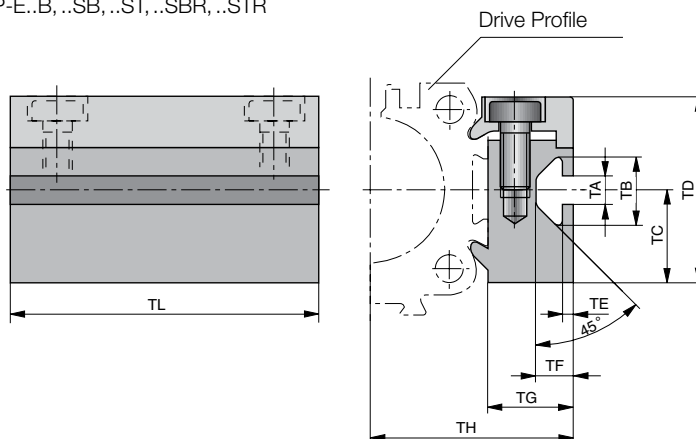

Series OSP-E20BHD to E50BHD

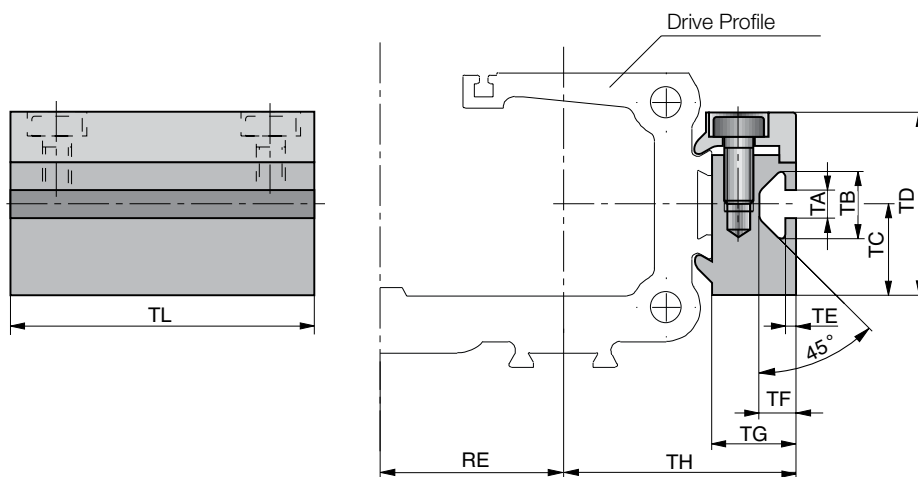

Dimension [mm] and Order Instructions

Series	RE	TA	TB	TC	TD	TE	TF	TG	TH	TL	Order No.	
											Standard	Stainless
OSP-E20	23	5.0	11.5	16	32	1.8	6.4	14.5	28	50	20007FIL	20187FIL
OSP-E25	26	5.0	11.5	16	32	1.8	6.4	14.5	34.5	50	20007FIL	20187FIL
OSP-E32	32	5.0	11.5	16	32	1.8	6.4	14.5	40.5	50	20007FIL	20187FIL
OSP-E50	44	8.2	20.0	20	43	4.5	12.3	20.0	58.0	80	20026FIL	20268FIL



P-A4P017GB

OSP-E

Adaptor Profile - Size 25, 32, 50

to connect

- **OSP-E with System Profiles**
- **OSP-E with Series OSP-E or OSP-P**

The mountings are supplied singly.

Adaptor Profile

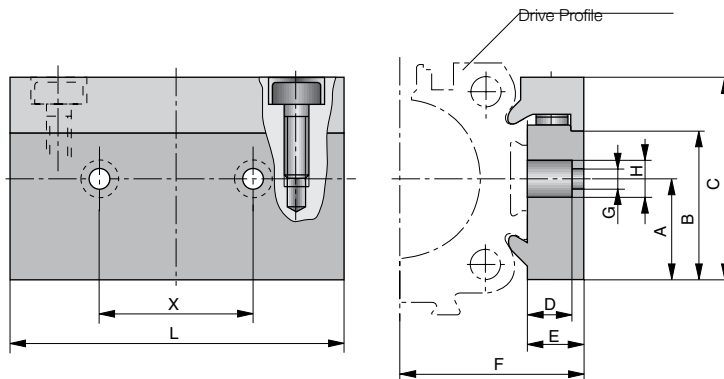

Dimension [mm] and Order Instructions

Series	for the connection to the driver of	A	B	C	D	E	F	G	H	L	X	Order No.
OSP-E25	OSP32-50	16	23	32	8.5	10.5	30.5	6.6	11	60	27	20850FIL
OSP-E32	OSP32-50	16	23	32	8.5	10.5	36.5	6.6	11	60	27	20850FIL
OSP-E50	OSP32-50	20	33	43	8.0	14.0	52	6.6	11	60	27	20851FIL

Connecting Possibilities

Connecting of Series OSP-E with System Profiles

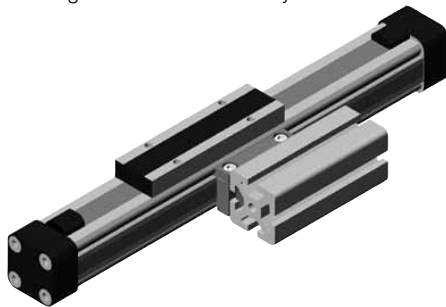

Connecting of Series OSP-E mit Series OSP-E/OSP-P

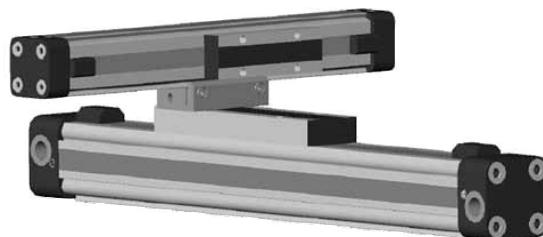

P-A4P017GB

OSP-E

**Trunnion Mounting EN / Pivot Mounting EL
- Size 25, 32, 50**

• **OSP-E..SBR, ..STR for Actuator with Spindle Drive and Piston Rod**

The trunnion mounting is fitted to the dovetail rails of the actuator profile and is continuously adjustable in axial direction.

The mountings are supplied in pairs.

Series OSP-E25SBR, 25STR to 50SBR, 50STR: Type EN-..

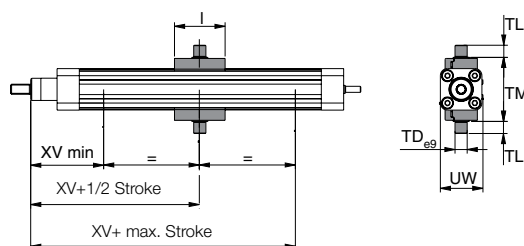

Material: Al

Dimension [mm] and Order Instructions - for Trunnion Mounting EN-..

Series	Typ	I	øTD e9	TL	TM	UW	XV min	XV+ 1/2 Stroke	XV+ max. Stroke	Order No.
OSP-E25SBR. STR	EN-E25	50	12	12	63	42	73.0	83	62.0	12235FIL
OSP-E32SBR. STR	EN-E32	50	16	16	75	52	76.5	90	69.5	12236FIL
OSP-E50SBR. STR	EN-E50	80	20	20	108	87	110	110	84.0	12237FIL

Series OSP-E25SBR, 25STR to 50SBR, 50STR: Type EL-..

Trunnion Mounting EN

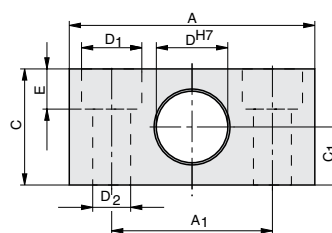

Pivot Mounting EL

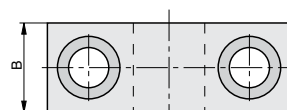

Material: Al

Dimension [mm] and Order Instructions – Pivot Mounting EL-..

Series	Typ	A	A ₁	B	C	C ₁	øD ^{H7}	øD ₁	øD ₂	E	Weight. (mass) (kg)	Order No.
OSP-E25SBR. STR	EL-032	55	36	20	26	13	12	13.5	8.4	9	0.06	PD23381
OSP-E32SBR. STR	EL-040/050	55	36	20	26	13	16	13.5	8.4	9	0.06	PD23382
OSP-E50SBR. STR	EL-063/080	65	42	25	30	15	20	16.5	10.5	11	0.10	PD23383



P-A4P017GB

OSP-E

Compensation



Content

Description	Page
Compensation (OSP-E..B, ..SB, ..ST)	156
Inversion Mounting (OSP-E..B, ..SB, ..ST)	158
Piston Rod Eye ISO 8139	159
Piston Rod Clevis ISO 8140	159
Piston Rod Compensation Coupling	160

P-A4P017GB

OSP-E

Clevis Mounting - Size 25, 32, 50

- **OSP-E..B Belt Actuator with Internal Plain Bearing Guide**
- **OSP-E..SB, ..ST Screw Actuator with Internal Plain Bearing Guide**

When external guides are used, parallelism deviations can lead to mechanical strain on the piston. This can be avoided by the use of a Compensation. Freedom of movement is provided as follows:

- Tilting in Direction of Movement
- Vertical Compensation
- Tilting Sideways
- Horizontal Compensation.

A stainless steel version is also available.

Series OSP-E25 to E32

OSP-E..B, ..SB, ..ST

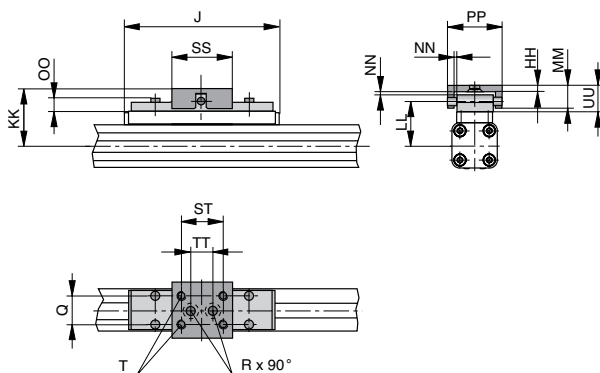

Series OSP-E50

OSP-E..B, ..SB, ..ST

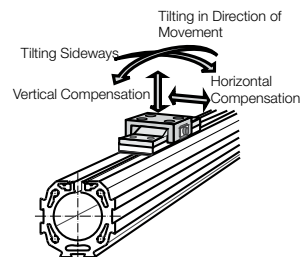
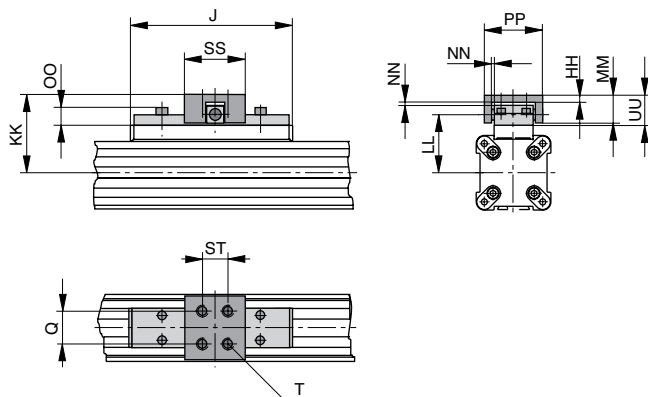

Dimension [mm]

Series	J	Q	T	øR	HH	KK	LL	MM	NN*	OO	PP	SS	ST	TT	UU	Order No. Standard	Stainless
OSP-E25	117	16	M5	5.5	3.5	52	39	19	2	9	38	40	30	16	21	20005FIL	20092FIL
OSP-E32	152	25	M6	6.6	6.0	68	50	28	2	13	62	60	46	40	30	20096FIL	20094FIL
OSP-E50	200	25	M6	-	6.0	79	61	28	2	13	62	60	46	-	30	20097FIL	20095FIL

*Dimension NN gives the possible plus and minus play in horizontal and vertical movement, which also makes tilting sideways possible.



P-A4P017GB

OSP-E

Clevis Mounting, Low Back Lash - Size 25, 32, 50

- **OSP-E..B Belt Actuator with Internal Plain Bearing Guide**
- **OSP-E..SB, ..ST Screw Actuator with Internal Plain Bearing Guide**

When external guides are used, parallelism deviations can lead to mechanical strain on the piston. This can be avoided by the use of a clevis mounting. In the drive direction the clevis mounting has a low backlash fit. Freedom of movement is provided as follows:

- Tilting in Direction of Movement
- Vertical Compensation
- Tilting Sideways
- Horizontal Compensation

A stainless steel version is also available.

Series OSP-E25 to E32

OSP-E..B, ..SB, ..ST

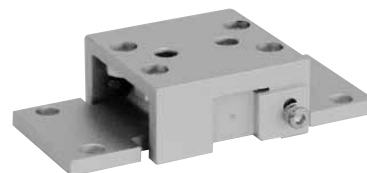
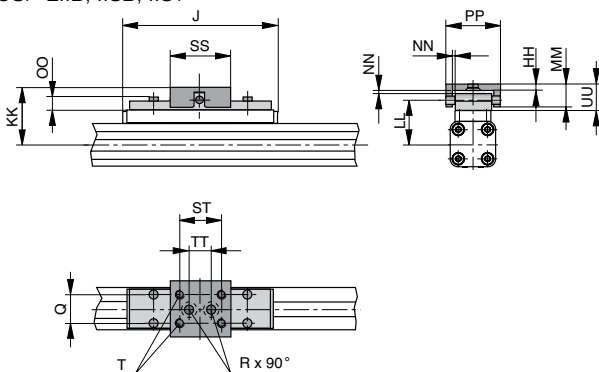

Series OSP-E50

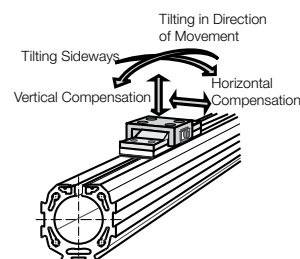
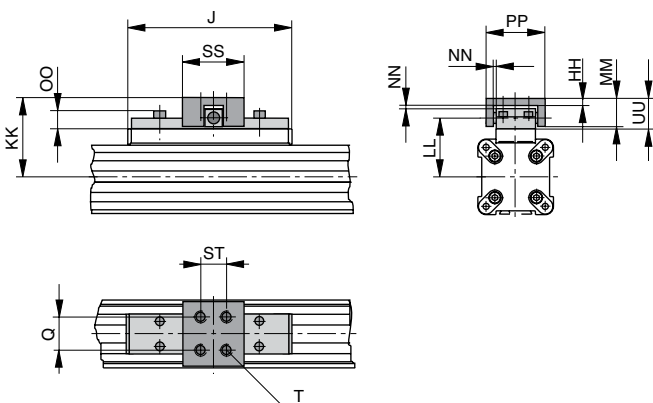

Dimension [mm]

Series	J	Q	T	øR	HH	KK	LL	MM	NN*	OO	PP	SS	ST	TT	UU	Order No. Standard	Stainless
OSP-E25	117	16	M5	5.5	3.5	52	39	19	2	9	49	40	30	16	21	20496FIL	20498FIL
OSP-E32	152	25	M6	6.6	6.0	68	50	28	2	13	69	60	46	40	30	20497FIL	20499FIL
OSP-E50	200	25	M6	-	6.0	79	61	28	2	13	69	60	46	-	30	20812FIL	20818FIL

*Dimension NN gives the possible plus and minus play in horizontal and vertical movement, which also makes tilting sideways possible.



P-A4P017GB

OSP-E

Inversion Mounting - Size 25, 32, 50

- **OSP-E..B Belt Actuator with Internal Plain Bearing Guide**
- **OSP-E..SB, ..ST Screw Actuator with Internal Plain Bearing Guide**

In dirty environments, or where there are special space problems, inversion of the cylinder is recommended. The inversion bracket transfers the driving force to the opposite side of the cylinder. The size and position of the mounting holes are the same as on the standard cylinder.

Stainless steel version on request.

Please note: Other components of the OSP system such as **profile mountings, magnetic switches** can still be mounted on the free side of the cylinder.

Important Note: May be used in combination with Compensation, ref. dimensions in page 143.

Series OSP-E25 to E32

OSP-E..B, ..SB, ..ST

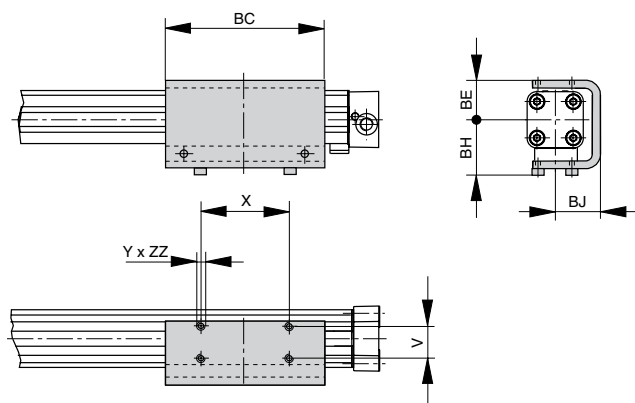

Series OSP-E50

OSP-E..B, ..SB, ..ST

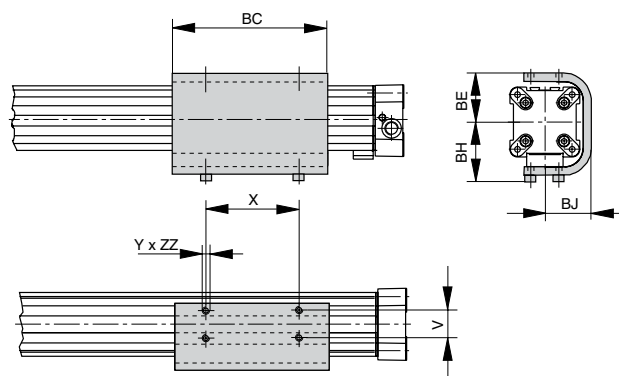

Dimension [mm] and Order Instructions

Series	V	X	Y	BC	BE	BH	BJ	ZZ	OrderNo.
OSP-E25	25	65	M5	117	31	43	33.5	6	20037FIL
OSP-E32	27	90	M6	150	38	51	39.5	6	20161FIL
OSP-E50	27	110	M6	200	55	65	52	8	20166FIL



P-A4P017GB

OSP-E

**Piston Rod Eye according to ISO 8139 /
Piston Rod Clevis according to ISO 8140**

- **OSP-E..SBR. ..STR Screw Actuator with Internal Plain Bearing Guide and Piston Rod**

Piston Rod Eye according to (CETOP RP103P) Typ: GA-..

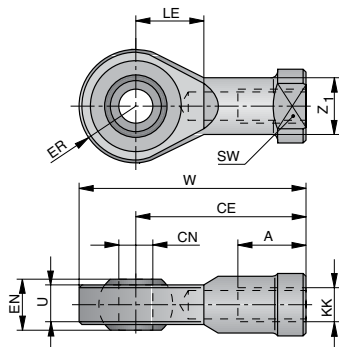

Dimension [mm] and Order Instructions. Weight

Series	Typ	A	CE	ØCN	EN	ER	KK	LE	SW	U	W	ØZ ₁	Weight [kg]	Order No.
OSP-E25SBR, STR	GA-M10x1.25	20	43	10	14	14	M10x1.25	15	17	10.5	57	15	0.072	KY6147
OSP-E32SBR, STR	GA-M10x1.25	20	43	10	14	14	M10x1.25	15	17	10.5	57	15	0.072	KY6147
OSP-E50SBR, STR	GA-M16x1.5	28	64	16	21	21	M16x1.5	22	22	15	85	22	0.21	KY6150

Piston Rod Clevis according to ISO 814 (CETOP RP102P) Type: GK-..

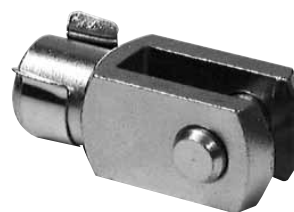
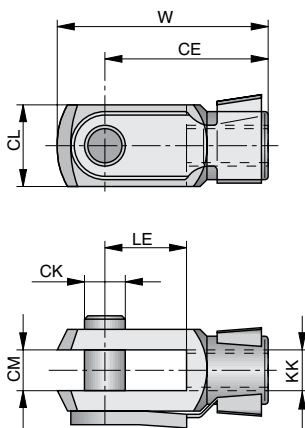

Dimension [mm] and Order Instructions, Weight

Series	Typ	ØCK	CE	CL	CM	KK	LE	W	Weight [kg]	Order No.
OSP-E25SBR, STR	GK-M 10x1.25	10	40	20	10	M10x1.25	20	52	0.08	KY6135
OSP-E32SBR, STR	GK-M 10x1.25	10	40	20	10	M10x1.25	20	52	0.08	KY6135
OSP-E50SBR, STR	GK-M 16x1.5	16	64	32	16	M16x1.5	32	83	0.30	KY6139



P-A4P017GB

OSP-E

Piston Rod Compensating Coupling

- OSP-E..SBR, STR Screw Acuator with Internal Plain Bearing Guide and Piston Rod

Angular Compensation

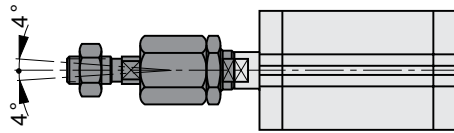

Radial Compensation of the Centre Axis

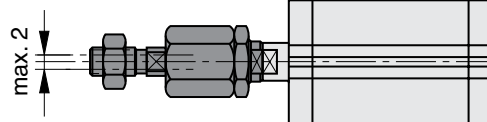

Piston Rod Compensating Coupling Type: AK-..

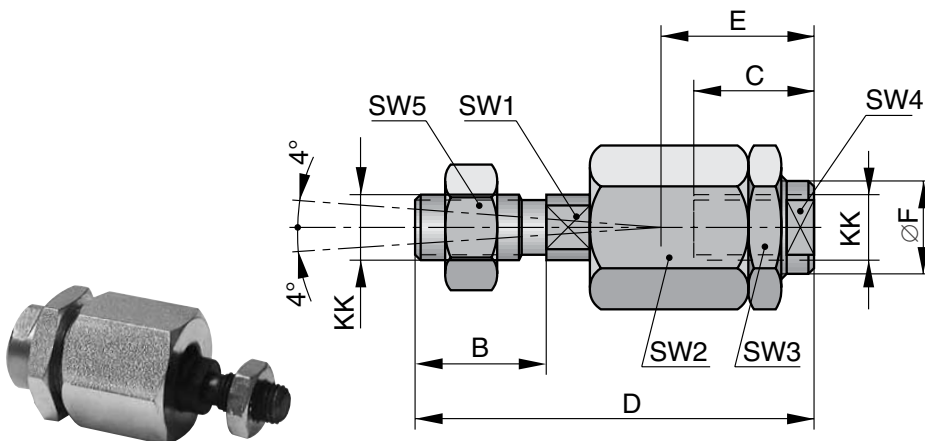

Dimension [mm] and Order Instructions, Weight

Series	Type	B	C	D±2	E	ØF	KK	SW1	SW2	SW3	SW4	SW5	Weight [kg]	OrderNo.
OSP-E25SBR, STR	AK-M10x1.25	20	23	73	31	21.5	M10x1.25	12	30	30	19	17	0.218	KY1129
OSP-E32SBR, STR	AK-M10x1.25	20	23	73	31	21.5	M10x1.25	12	30	30	19	17	0.218	KY1129
OSP-E50SBR, STR	AK-M16x1.5	40	32	108	45	33.5	M16x1.5	19	41	41	30	30	0.637	KY1133



P-A4P017GB
OSP-E

Guide Mounting

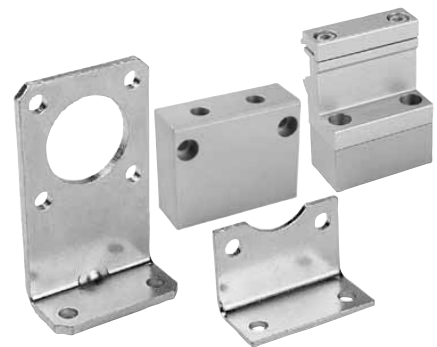



Content

Description	Page
Overview	162
End Cap Mounting	163
Profile Mounting	164

- **OSP-E..B Belt Acuator with Internal Plain Bearing Guide**
- **OSP-E..SB, ..ST Screw Actuator with Internal Plain Bearing Guide**

Overview

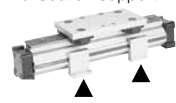
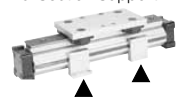
Type of Mounting	Type	Versions - OSP-Guide									
		SLIDELINE PROLINE MULTIBRAKE			POWERSLIDE						
		25	32	50	25/ 25	25/ 35	25/ 44	32/ 35	32/ 44	50/ 60	50/ 76
 End Cap Mounting	Type A1										
	Type A2	○	○								
	Type A3				○	○		○			
 End Cap Mounting reinforced	Type B1	x	x		x	x	x	x	x		
	Type B3										
	Type B4						○		○		
 End Cap Mounting	Type C1			x						x	x
	Type C2			○							
	Type C3									○	
	Type C4										○
 Mid-Section Support Narrow	Type D1	x	x	x	x	x	x	x	x	x	x
	Type E1	x	x	x	x	x	x	x	x	x	x
 Mid-Section Support Wide	Type E2	○	○	○							
	Type E3				○	○		○		○	
	Type E4						○		○		○

X = mounting position carriage top (12 clock position)
 O = mounting position carriage side (3 or 9 clock position)
 ■ = available components

*** Please note:**

With series OSP-E-spindle the end cap mountings A, B and C can only be fitted to the side opposite to the drive shaft. On the side of the drive shaft we recommend to use our profile mountings (page 135 ff).

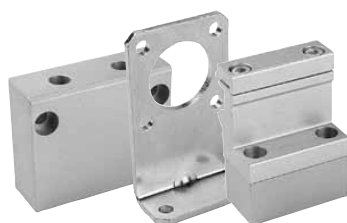

P-A4P017GB

OSP-E

End Cap Mounting

Series OSP – E25, E32: Type A

OSP-E..B,..SB,..ST

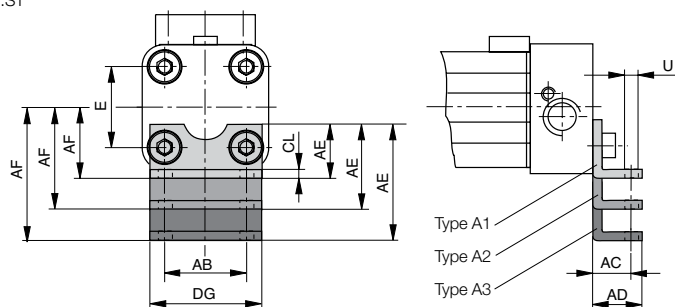

Series OSP – E25, E32: Type B

OSP-E..B,..SB,..ST

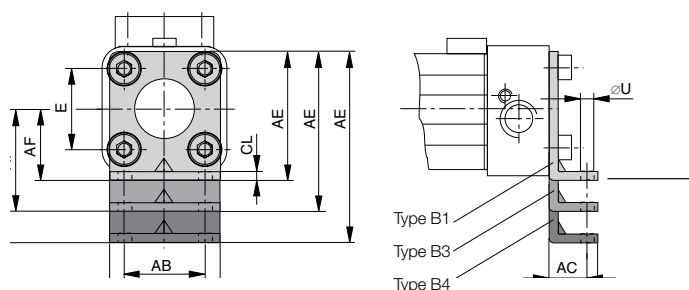

At the end face of each end caps there are four holes with internal threads to fix the drive. The hole layout is square so that the drive can be fitted on the bottom, the top or either side.

Material: Series OSP-25, 32: steel, zinc galvanized series OSP-50: Aluminium, anodized. **The mountings are supplied in pairs.**

Dimension [mm]

- AE and AF (depending on type of mounting)

Type of mount.	Dimension AE at Size			Dimension AF at Size		
	25	32	50	25	32	50
A1	18	20	-	22	30	-
A2	33	34	-	37	44	-
A3	45	42	-	49	52	-
B1	42	55	-	22	30	-
B3	-	-	-	-	-	-
B4	80	85	-	60	60	-
C1	-	-	30	-	-	48
C2	-	-	39	-	-	57
C3	-	-	54	-	-	72
C4	-	-	77	-	-	95

Dimension [mm]

Series	E	øU	AB	AC	AD	CL	D
OSP-E25	27	5.8	27	16	22	2.5	39
OSP-E32	36	6.6	36	18	26	3.0	50
OSP-E50	70	9.0	40	12.5	24	-	86

* see survey for mounting type on page 129 ff.

Series OSP – E50: Type C

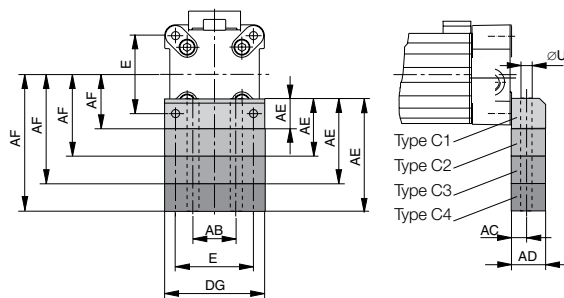

Series OSP-E25, E32, E50: Type E (mounting with through hole)

OSP-E..B, ..SB, ..ST, ..SBR, ..STR

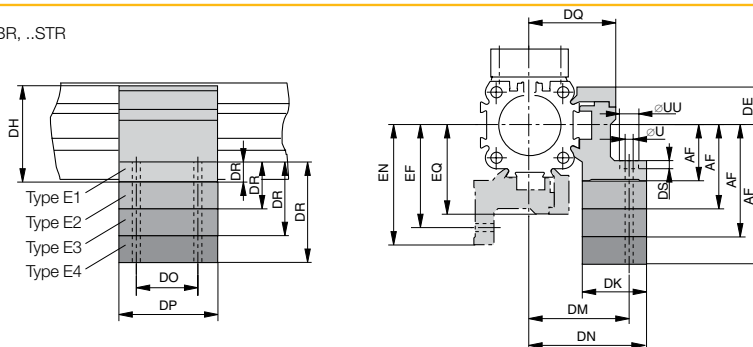

Information on type E1 and D1: The Profile Mountings can also be fitted to the bottom side of the drive. In this case please observe the new centre line dimensions of the drive. For layout information please refer to the page 100 ff. Stainless version on request.

Dimension [mm]

- Dimension DR and AF (depending on type of mounting)

Type of mount.	Dimension DR at Size			Dimension AF at Size		
	25	32	50	25	32	50
D1	-	-	-	22	30	48
E1	8	10	10	22	30	48
E2	23	24	19	37	44	57
E3	35	32	31	49	52	72
E4	46	40	57	60	60	95

Series OSP-E25, E32, E50: Type D1 (mounting with internal thread)

OSP-E..B, ..SB, ..ST, ..SBR, ..STR

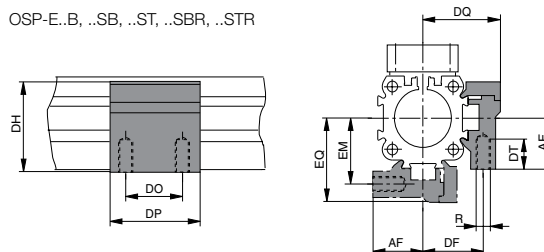

Dimension [mm]

Series	R	U	UU	DE	DF	DH	DK	DM	DN	DO	DP	DQ	DS	DT	EF	EM	EN	EQ
OSP-E25	M5	5.5	10	16	27	38	26	40	47.5	36	50	34.5	5.7	10	41.5	28.5	49	36
OSP-E32	M5	5.5	10	16	33	46	27	46	54.5	36	50	40.5	5.7	10	48.5	35.5	57	43
OSP-E50	M5	7	-	23	40	71	34	59	67	45	60	52	-	11	64	45	72	57

Order Instructions for Mountings Type A - Type B - Type C - Type D - Type E

Type of Mounting (Versions)	Order No. Size		
	25	32	50
A1 ¹⁾	2010FIL	3010FIL	-
A2 ¹⁾	2040FIL	3040FIL	-
A3 ¹⁾	2060FIL	3060FIL	-
B1 ¹⁾	20311FIL	20313FIL	-
B3 ¹⁾	-	-	-
B4 ¹⁾	20312FIL	20314FIL	-
C1 ¹⁾	-	-	5010FIL
C2 ¹⁾	-	-	20349FIL
C3 ¹⁾	-	-	20350FIL
C4 ¹⁾	-	-	20351FIL
D1 ²⁾	20008FIL	20157FIL	20162FIL
E1 ²⁾	20009FIL	20158FIL	20163FIL
E2 ²⁾	20352FIL	20355FIL	20361FIL
E3 ²⁾	20353FIL	20356FIL	20362FIL
E4 ²⁾	20354FIL	20357FIL	20363FIL



¹⁾ The mountings are supplied in pairs. ²⁾ The mountings are supplied simply.

Magnetic Field Sensors



Type P8S-G

The new generation of t-slot sensors convince with easy mounting avoiding special tools and with a drop-in mounting. Due to new electronic the hysteresis is very small and allows a very accurate switching point. Magnetic Field Sensors are used for contactless electric sensing of the carrier position, e.g. for end or homing positions of a linear actuator. The field of magnets mounted as standard into the carriage activate the sensor.

Electric Service Life, Protective Measures

Type RS magnetic sensors are sensitive to excessive currents and inductions. With high switching frequencies and inductive loads such as relays, solenoid valves or lifting magnets, service life will be greatly reduced. With resistive and capacitive loads with high switch-on current, such as light bulbs, a protective resistor should be fitted. This also applies to long cable lengths and voltages over 100 V.

In the switching of inductive loads such as relays, solenoid valves and lifting magnets, voltage peaks (transients) are generated which must be suppressed by protective diodes, RC loops or varistors.

Connection Examples

Load with protective circuits

- (a) Protective resistor for light bulb
- (b) Freewheel diode on inductivity
- (c) Varistor on inductivity
- (d) RC element on inductivity

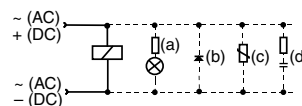

For the type ES, external protective circuits are not normally needed.

Carriage Speed / Reaction Time

Carriage speed and switching distance affect signal duration and should be considered in conjunction with the minimum reaction time of ancillary control equipment.





In accordance to this, the contact travel must be included in the calculation.

$$\text{Min. reaction time} = \frac{\text{Switching distance}}{\text{Piston speed}}$$

P-A4P017GB

OSP-E

Magnetic Field Sensors

Series		P8S-G ¹⁾ - insertable into T-Slot from top					
Type		M8R ²⁾		FL ³⁾			
							
CE, cULus, RoHs							
Output Function		0,3m Cable	3m Cable	10m Cable	0,3m Cable	3m Cable	10m Cable
PNP	NO	P8S-GPCHX	P8S-GPFAX	P8S-GPFDX			
	NC	P8S-GQCHX	P8S-GQFAX	P8S-GQFDX			
NPN	NO	P8S-GNCHX	P8S-GNFAX	P8S-GNFDX			
	NC	P8S-GMCHX	P8S-GMFAX	P8S-GMFDX			
REED	NO				P8S-GRCHX	P8S-GRFAX	P8S-GRFDX
	NC				P8S-GECNX	P8S-GEFFX	P8S-GEFRX
Technical Data		Electrical			Reed		
Electrical Characteristics							
Electric Configuration		3-pole			2-pole		
Indicator LED yellow		yes			yes (not NC)		
Operating Voltage U _b [V]		10 - 30 DC			10 - 30 AC/DC		
Ripple of U _b [%]		≤ 10			≤ 10		
Voltage Drop U _d [V]		≤ 2			≤ 3		
Power Consumption ⁴⁾ [mA]		≤ 10					
Continuous Current I _a [mA]		≤ 100			≤ 500 (NO ≤ 100)		
Max. Switching Capacity [W]		≤ 6			≤ 10		
Switchable Capacity Load @ 100W @ 24VDC [nF]					100		
Switching Frequency [Hz]		≤ 1.000			≤ 400		
Time delay before availability [ms]		0,5 / 0,5			1,5 / 0,5		
Sensitivity [mT]		2,8			3		
Hysteresis [mT]		0,7			≥ 0,2		
EMC ⁶⁾		yes			yes		
Lifetime		unlimited			≥ 20*10 ⁶ Cycles		
Short Circuit Protection ⁵⁾ , Reverse Polarity Protection, Power-Up Pulse Suppression, Protection for Inductive Load		yes					
ATEX Version		on request					
Mechanical Characteristics							
Housing		PA12					
Cable Type		PUR / black					
Cable Cross Section [mm ²]	Connector 3-pole	3 x 0,14	3 x 0,14	Connector 3-pole	2 x 0,14	2 x 0,14	
Bending Radius Fixed Installation [mm]		≥ 30					
Bending Radius Moving [mm]		≥ 45					
Shock Resistance							
Protection ⁷⁾ [IP]		67					
Ambient Temperature Range T _a [°C]		-25 ... +75					
Shock ⁸⁾ / Vibration ⁹⁾		30 g, 11 ms / 10 to 55 Hz, 1 mm					

¹⁾ without OSP-E..STR

²⁾ plug M8 with rotatable nut

³⁾ Cable with Flying Leads

⁴⁾ unloaded U_b = 24V

⁵⁾ clocked

⁶⁾ to EN 60529

⁷⁾ to EN 60529

⁸⁾ to EN 60068-2-27

⁹⁾ to EN 60068-2-6



P-A4P017GB

OSP-E

Magnetic Sensors

Switching Function and Electrical Connection

Reed 2-pole

normally open

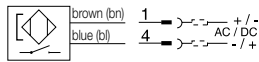

normally closed

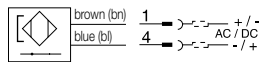

PNP 3-pole

normally open



normally closed

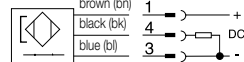

NPN 3-pole

normally open

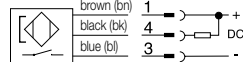

normally closed

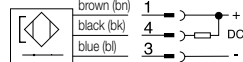

Dimensions [mm]- Type P8S-G

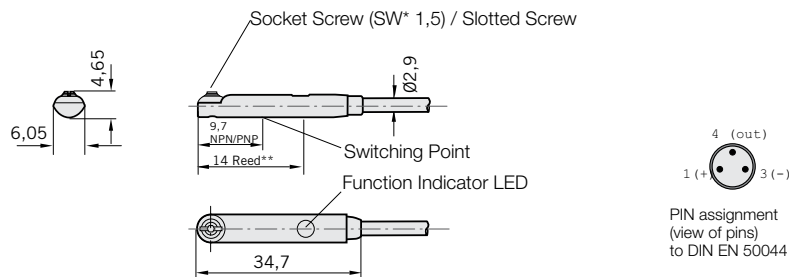

P8S-... cable with flying leads

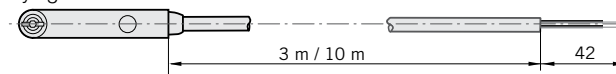

P8S-... plug M8, rotatable

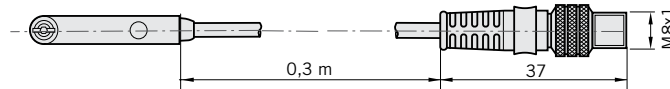

* = Wrench Size
** = Switching Point Reed

Installation for T-Slot Sensors

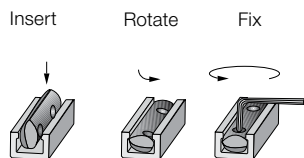

Installation for Dove Tail Groove

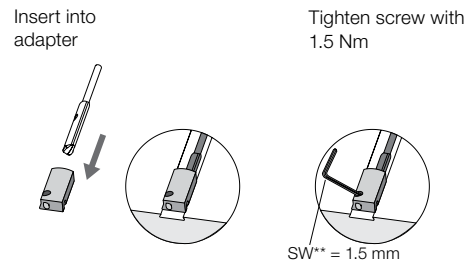

*Adapter included in scope of supply of magnetic sensors P8S.
**= Wrench Size

Position of Magnetic Sensors / Permanent Magnets OSP-E..BHD

Standard Version

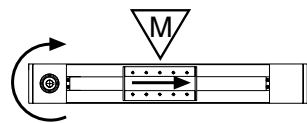

Drive Shaft Option = 0*

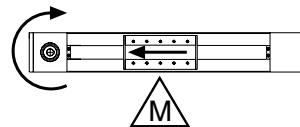

Drive Shaft Option = 1*

Bi-parting Version

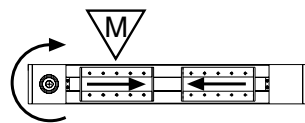

Drive Shaft Option = 2*

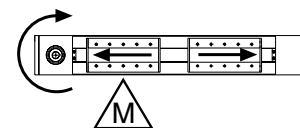

Drive Shaft Option = 3*

* Drive shaft oder code BHD page 24

When arranging the magnetic sensors, please mind the position of the magnets integrated in the carrier as a function of the operating direction. „M“ indicates where magnet is fitted in carrier.

Dimensions for Magnetic Sensor Set Series OSP-E..BV

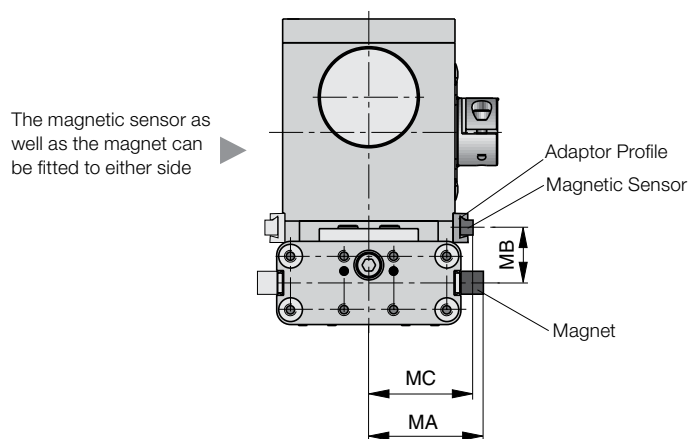
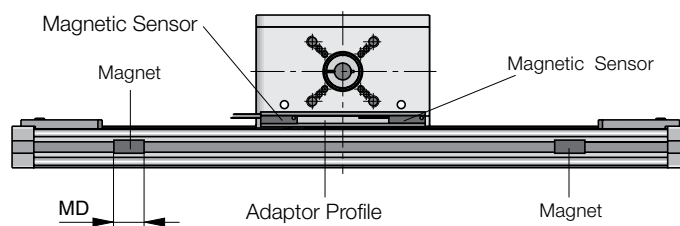

Dimensions see page 35

Magnetic sensors and magnets are externally fitted to the OSP-E..BV. For this purpose please order the magnetic sensor set (consisting of 2 magnetic sensors, 1 fastening rail and 2 magnets) for contactless position sensing.

P-A4P017GB

OSP-E

Magnetic Sensors

Dimension [mm]

OSP-E..BHD

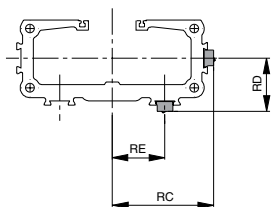

OSP-E..B, ..SB, ..ST., ..SBR, ..STR

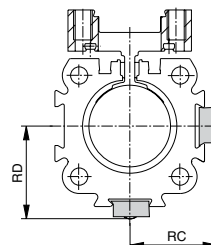

Dimension [mm]

Series	Dimensions						
	RC	RD	RE	MA	MB	MC	MD
OSP-E20BHD	41.5	26.6	23	-	-	-	-
OSP-E25BHD	51	27	26	-	-	-	-
OSP-E32BHD	63	34	32	-	-	-	-
OSP-E50BHD	87	48	34	-	-	-	-
OSP-E20BV	-	-	-	46	23.7	42.3	35
OSP-E25BV	-	-	-	56	26	51	35
OSP-E25*	25	27	-	-	-	-	-
OSP-E32*	31	34	-	-	-	-	-
OSP-E50*	43	48	-	-	-	-	-

* = ..B, ..SB, ..ST, ..SBR, ..STR

Order Numbers

Magnetic Sensor for OSP-E..STR (low sensitivity)

Reed NO (2-wire), S-slot, flying leads, 5 m	KL3096*
Reed NC (2-wire), S-slot, flying leads, 5 m	KL3388*
PNP NO (3-wire), S-slot, M8 connector, 100 mm	KL3098*

Magnetic Sensor Set for OSP-E..BV

2 Magnetic sensor, Reed NC (2-wire), 1 mounting rail, 2 magnets	18210FIL
---	----------

Connection Cables, Suitable for Cable Chain

M8 Plug with 5 m Cable	KL3186*
M8 Plug with 10 m Cable	KL3217*
M8 Plug with 15 m Cable	KL3216*

* Detailed specifications for KL-Series on request.

P-A4P017GB

OSP-E

P-A4P017GB

OSP-E

Position Measuring System SFI-plus



ORIGA-Sensoflex (incremental displacement measuring system)

Series SFI-plus

- **OSP-E..SB Ball Screw Acuator with Internal Plain Bearing Guide**
- **OSP-E..ST Trapezoidal Screw Acuator with Internal Plain Bearing Guide**

Special Properties

- Contactless, Magnetic Displacement Measuring System
- Freely Selectable Displacement Length up to 32 m
- Resolution 0.1 mm
- Displacement Speed up to 10 m/s
- Suited for Linear and Gyrotory Movements
- For Almost all Control and Display Units with Suitable Counter Input

The magnetic displacement measuring system SFI-plus consists of 2 main components:

- **Measuring Scale** self-adhesive, magnetic measuring scale
- **Sensing Head** converts the magnetic poles into electric signals which are then processed by counter inputs down stream (e.g. PLC, PC, digital counters)

P-A4P017GB

OSP-E

Displacement Measuring System

Series SFI- Plus SensoFlex Incremental

Type	
Output Function	21210FIL
Resolution [mm]	0.1 / 1 Flank Evaluation
Pole Length Scale [mm]	5
Max. Speed [m/s]	10
Repeating Accuracy	± 1 Increment
Distance Sensor / Scale [mm]	2
Switching Output	Push-Pull
Electric Characteristics	
Operating Voltage U_b [V DC]	10 - 30
Voltage Drop [V]	≤ 2
Continuous Current per Output [mA]	≤ 40
Power Consumption ¹⁾ [mA]	≤ 15
Short-circuit Protection, Reverse Voltage Protection, Protection against Inductive Switch-off Peak	yes
Electrostatic Discharge [kV]	8 kV Contact A, 15 kV without Contact A
Fast Transists Signals, Burst (DC-Connections) [kV]	1, A - 2, B
Mechanical Characteristics	
Housing	Aluminium
Cable Length [m]	5.0 – Fixed, Open End
Cable Cross-section [mm ²]	6 x 0.14 + 2 x 0.22
Type of Cable	PUR, Black
Bending Radius [mm]	41
Ambient Conditions	
Encapsulation Class ²⁾ [IP]	67
Ambient Temperature Range T_a [°C]	-25 to +85
Shock ³⁾ / Vibration ⁴⁾	(11 ms) 300 m/s ² / (55 Hz to 2000 Hz) 300 m/s ²

¹⁾ U_b = 24V, Switched on , no load
²⁾ according to EN60529

³⁾ according to EN 60068-2-6
⁴⁾ according to EN 60068-2-27

P-A4P017GB

OSP-E

Dimensions [mm] - in Combination with OSP-E Actuators

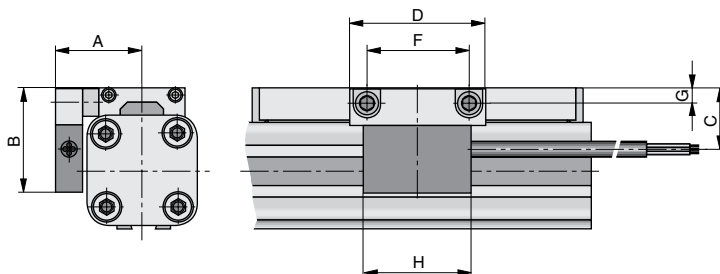

SFI-plus in connection with electric actuators of series OSP-E..ST

The SFI-plus can be mounted directly to the electric actuator of series OSP-E..ST by means of a special mounting kit. The position of the sensing head is generally staggered by 90° to the carrier. For later installation a corresponding carrier kit with threaded holes can be ordered.

SFI-plus in connection with electric actuators of series OSP-E..SB

The displacement measuring system in connection with series OSP-E..SB can only be retrofitted, if the system is reconditioned by the manufacturer.

Dimension [mm]

Series	A	B	C	D	F	G	H
OSP-E25SB, ST	32.0	39.0	23.0	50.0	38.0	5.5	40.0
OSP-E32SB, ST	37.5	46.0	30.0	50.0	38.0	6.5	40.0
OSP-E50SB, ST	49.5	55.0	39.0	50.0	38.0	6.5	40.0

Order Instructions

Description	Order No.
Sensing Head with Measuring Scale – Resolution 0,1 mm (please Indicate Scale Length)	21240FIL
Sensing Head – Resolution 0.1 mm (spare part)	21210FIL
Measuring Scale per meter for (to be replaced)	21235FIL
Mounting kit for OSP-P25	21213FIL
Mounting kit for OSP-P32	21214FIL
Mounting kit for OSP-P50	21216FIL

* The overall length of the measuring scale results from the dead length of the actuator and the stroke length. For dead lengths for actuators of series OSP-E see table.

Series	Dead Lengths (mm)
OSP-E25SB, ST	154
OSP-E32SB, ST	196
OSP-E50SB, ST	280

Example:

Actuator OSP-E, Ø25 mm, Stroke 1000 mm

Dead Length + Stroke = Overall Length of the Measuring Scale
 154 mm + 1,000 mm = 1,154 mm



P-A4P017GB
OSP-E

Cable Cover

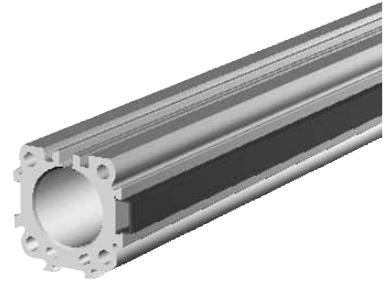

P-A4P017GB

OSP-E

Cable Cover - Ø 20, 25, 32, 50 mm

For clean guidance of magnetic switch cables along the cylinder body.
Contains a maximum of 3 cables with diameter 3 mm.

Material: Plastic
Colour: Red
Temperature Range: -10 to +80°C

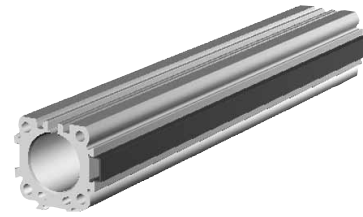

Series OSP-E..B,..SB,..ST,..SBR,..STR – Dimensions [mm]

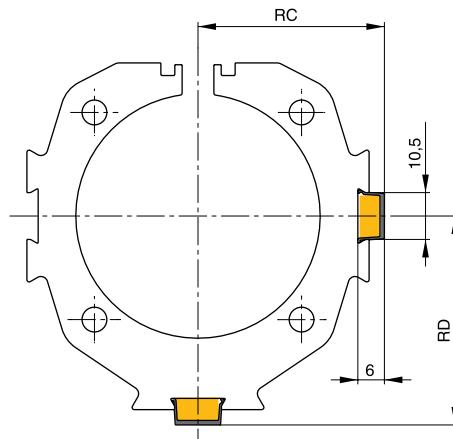

Series OSP-E..BHD – Dimensions [mm]

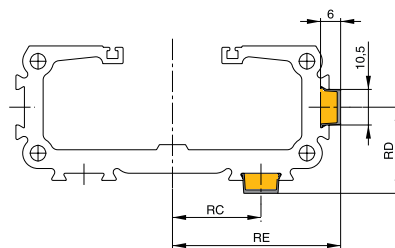

Dimension [mm] and Order Instructions

Series	RC	RD	RE	Order No.
OSP-E25*	23.5	25.5	-	13039FIL Minimum Length: 1 m Max. Profile Length: 2 m Multiple Profiles can be used.
OSP-E32*	29.5	32.0	-	
OSP-E50*	41.5	46.5	-	
OSP-E20BHD	23.0	25.0	40.0	
OSP-E25BHD	26.0	25.5	49.5	
OSP-E32BHD	32.0	32.0	61.5	
OSP-E50BHD	44.0	46.5	85.5	

*B, SB, ST, SBR, STR



OSP-E Multi-Axis Connections for Electric Actuators

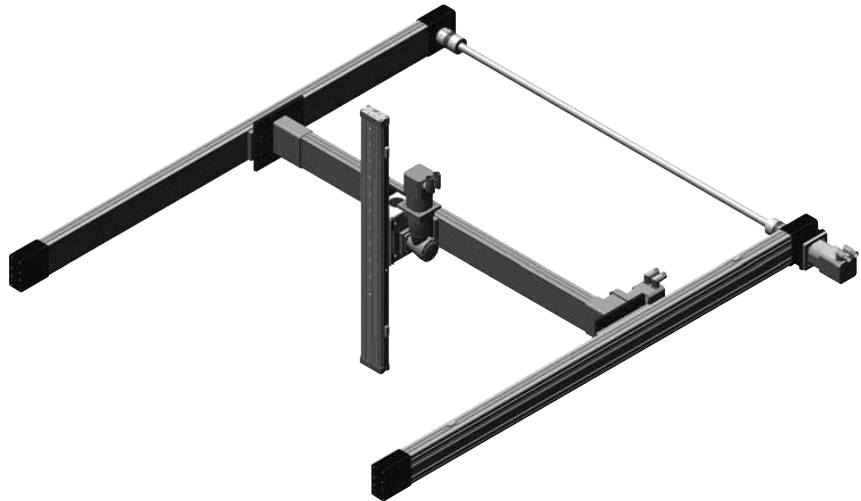

Content

Description	Page
Overview	179
Adapter Plates	181
Intermediate Drive Shafts	191

P-A4P017GB

OSP-E

The System Concept

Multi-Axis Connection System – Simplifies Engineering and Installation

A completely new system for easy connection of OSP-E actuators in multi-axis systems.

Multi-Axis-Connections

With this highly adaptable system for connection of actuators in multi-axis arrangements, Parker offers design engineers complete flexibility. A wide range of adapter plates, profile mountings and intermediate drive shafts simplify engineering and installation.

The connection system enables actuators to be mounted in
carrier to carrier,
carrier to profile,
carrier to end cap mounting,
carrier to end cap.

Developed for the heavy-duty belt drive series OSP-E..BHD, the system provides cross-connection with the same series and also other actuator series in the ORIGA SYSTEM PLUS range.



Multi-Axis-Connection System

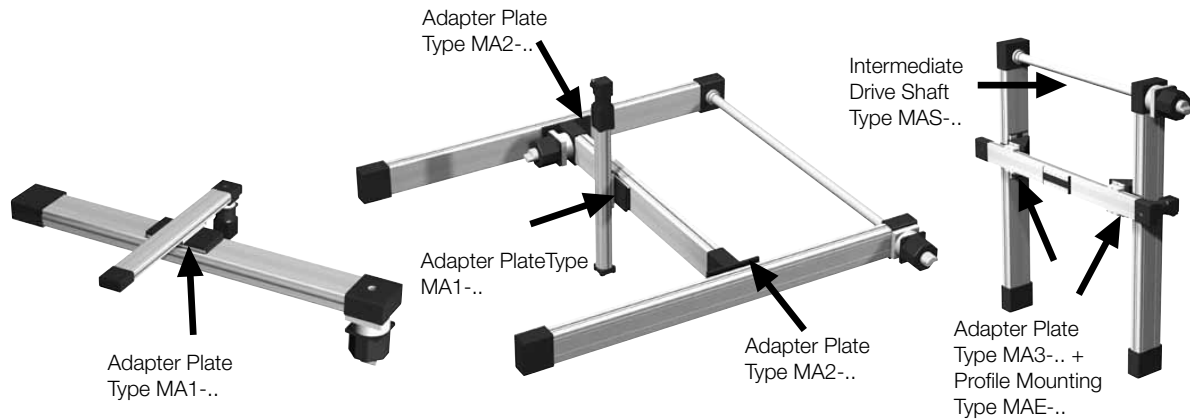

* For available standard combinations see page 170.

Adapter Plate Type MA1-..* For connecting carrier to carrier, carrier to profile mounting or carrier to end cap mounting.	Combination C*	Combination P*	Combination EM*
	Combination C*	Combination P*	Combination EM*
Adapter Plate Type MA2-..* For connecting carrier to end cap	Combination E*	Combination E*	Combination E*
	Combination P*	Combination P*	
Adapter Plate Type MA3-..* For connecting 90° carrier to profile mounting or carrier to end cap mounting.	Combination EM*	Combination EM*	
Profile Mounting Type MAE-..			
Intermediate Drive Shaft Type MAS-..			

Available Mounting Combination

Combination C*

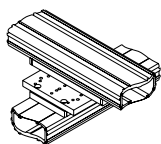

Combination P

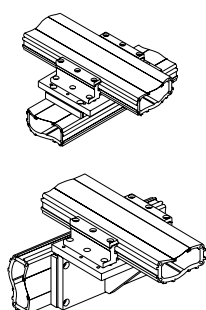

Combination E*

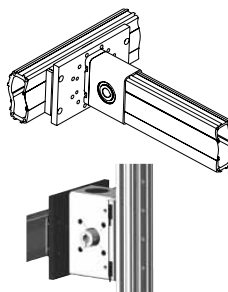

Combination EM*

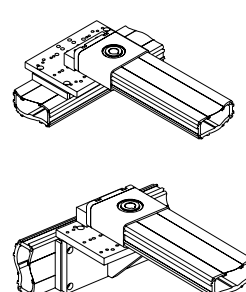

Illustrations show OSP-E..BHD examples

Series	25BHD				32BHD				50BHD				25BV	25B/SB/ST				32B/SB/ST				50B/SB/ST					
	Type	C ¹	P ²	E ³	EM ⁴	C ⁵	P ⁶	E ⁷	EM ⁸	C ⁹	P ¹⁰	E ¹¹	EM ¹²	E ¹¹	C ¹³	P ¹⁴	E ¹⁵	EM ¹⁶	C ¹⁷	P ¹⁸	E ¹⁹	EM ²⁰	C ²¹	P ²²	E ²³	EM ²⁴	
OSP-E25BHD	MA1-25	X	X		X	X	X		X						X	X		X	X	X	X	X	X	X	X	X	X
OSP-E32BHD	MA1-32	X	X		X	X	X		X	X	X		X					X	X		X	X	X	X	X	X	X
OSP-E50BHD	MA1-50	X	X		X	X	X		X	X	X		X				X						X	X		X	
OSP-E25BHD	MA2-25			X				X																		X	
	MA2-32													X													
OSP-E32BHD	MA2-32			X				X				X		X												X	
OSP-E50BHD	MA2-50			X				X				X		X												X	
OSP-E25BHD	MA3-25		X		X		X		X						X		X		X	X	X	X	X	X	X	X	X
OSP-E32BHD	MA3-32		X		X		X		X		X		X						X	X	X	X	X	X	X	X	X
OSP-E50BHD	MA3-50		X		X		X		X		X		X											X	X	X	X

Abbreviations:

C = MAn to Carrier

P = MAn to Profile Mounting

E = MAn to End Cap

EM = MAn to End Cap Mounting (n = 1, 2, 3)

* For type OSP-E..SBR/..STR combination P is available only.

Values in superscript refer to corresponding adapter plate dimensions on page 167 ff. E.g. dimensions corresponding to combination option "C" for adapter plate MA1-50 connected to an OSP-E32BHD carrier are shown with superscript number 5 on the MA1-50 adapter plate page 167 ff.

Other combinations on request.

Linear Actuators see page 11 ff, 27 ff, 39 ff, 43 ff, 53 ff, 67 ff, 79 ff



Dimensions [mm] Adapter Plate OSP-E 25, Typ: MA1-25

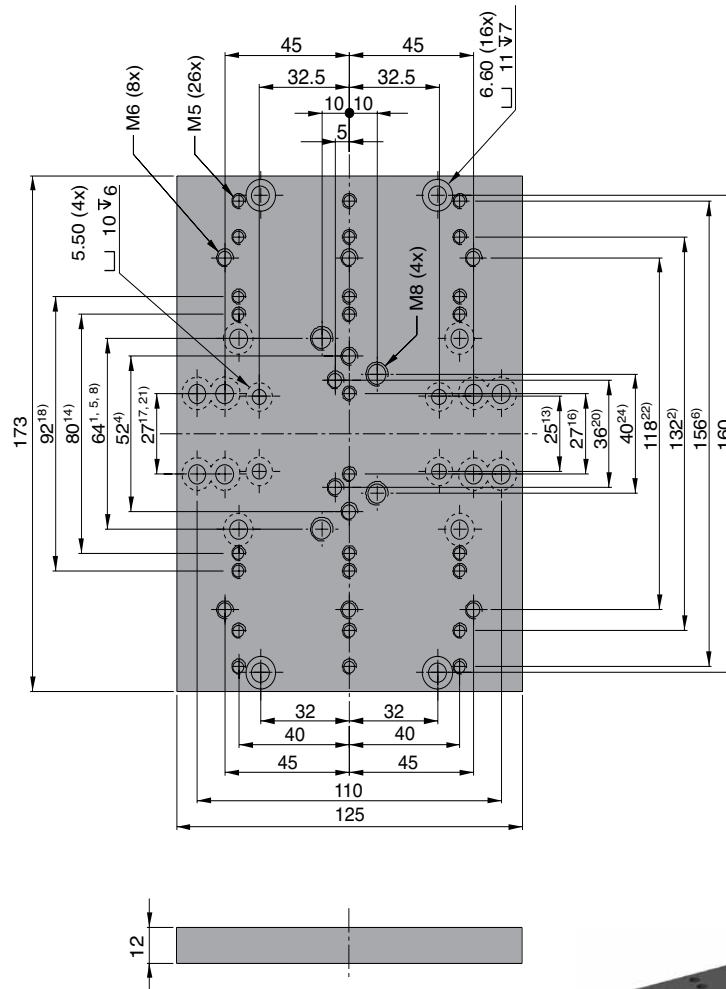

Dimensions with superscript values refer to the corresponding available options detailed on page 180. e.g. Dimensions with superscript number 5 correspond to the option "C" for OSP-E32BHD actuator.

Order Instructions and Weight

Description	Weight (mass) [kg]	Order No.
Adapter Plate Type MA1-25	0.7	12269FIL

Linear Actuators see page 11 ff, 27 ff, 39 ff, 43 ff, 53 ff, 67 ff, 79 ff

Dimensions [mm] Adapter Plate OSP-E 32, Type: MA1-32

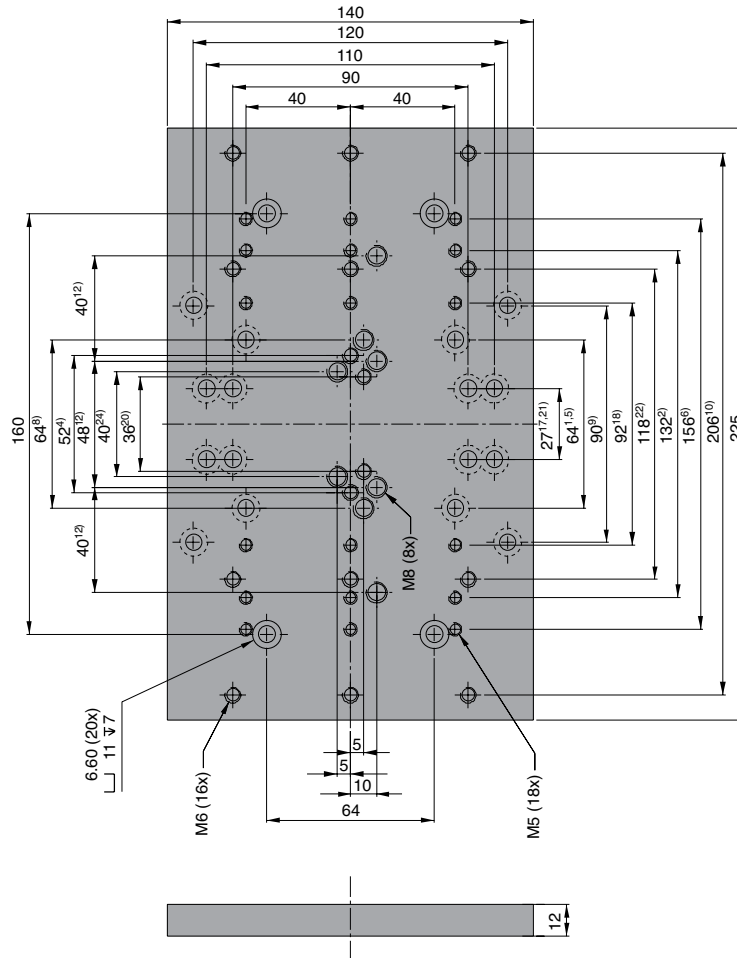

Dimensions with superscript values refer to the corresponding available options detailed on page 180. E.g. dimensions with superscript number 5 correspond to the option "C" for OSP-E32BHD actuator.

Order Instructions and Weight

Description	Weight (mass) [kg]	Order No.
Adapter Plate Type MA1-32	1.0	12272FIL

Linear Actuators see page 11 ff, 27 ff, 39 ff, 43 ff, 53 ff, 67 ff, 79 ff



P-A4P017GB

OSP-E

Adapter Plate

Dimensions [mm] Adapter Plate OSP-E 50, Type: MA1-50

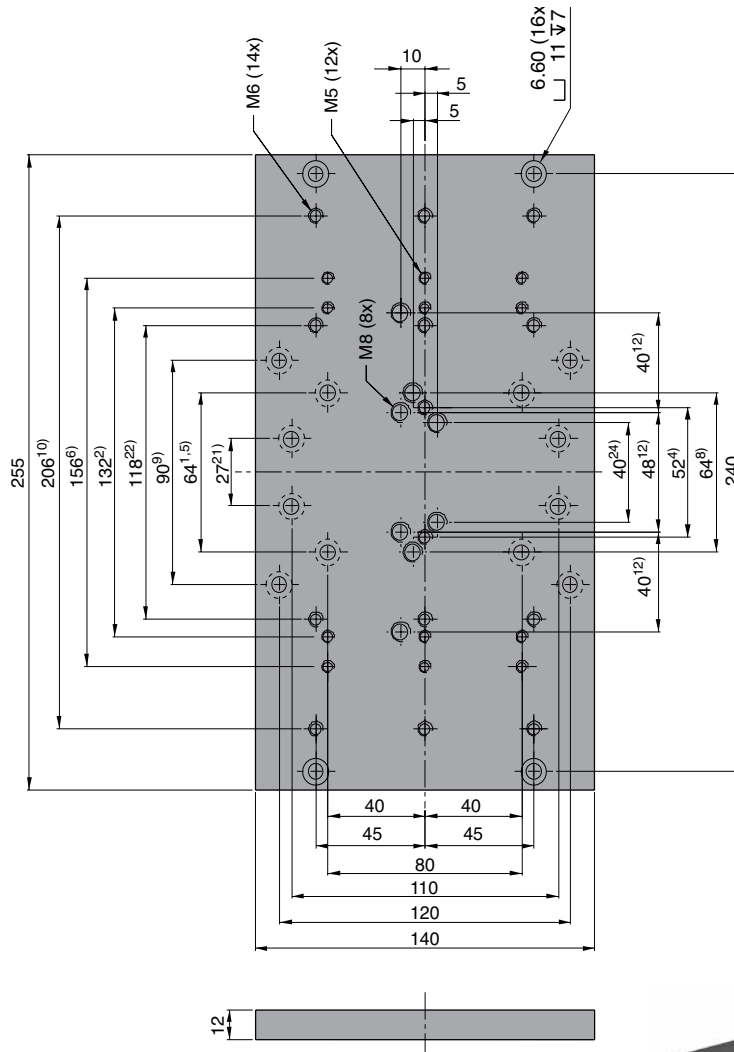

Dimensions with superscript values refer to the corresponding available options detailed on page 180. E.g. dimensions with superscript number 5 correspond to the option "C" for OSP-E32BHD actuator.

Order Instructions and Weight

Description	Weight (mass) [kg]	Order No.
Adapter Plate Type MA1-50	1.1	12275FIL

Linear Actuators see page 11 ff, 27 ff, 39 ff, 43 ff, 53 ff, 67 ff, 79 ff



P-A4P017GB

OSP-E

Adapter Plate

Dimensions [mm] Adapter Plate OSP-E 25, Type: MA2-25

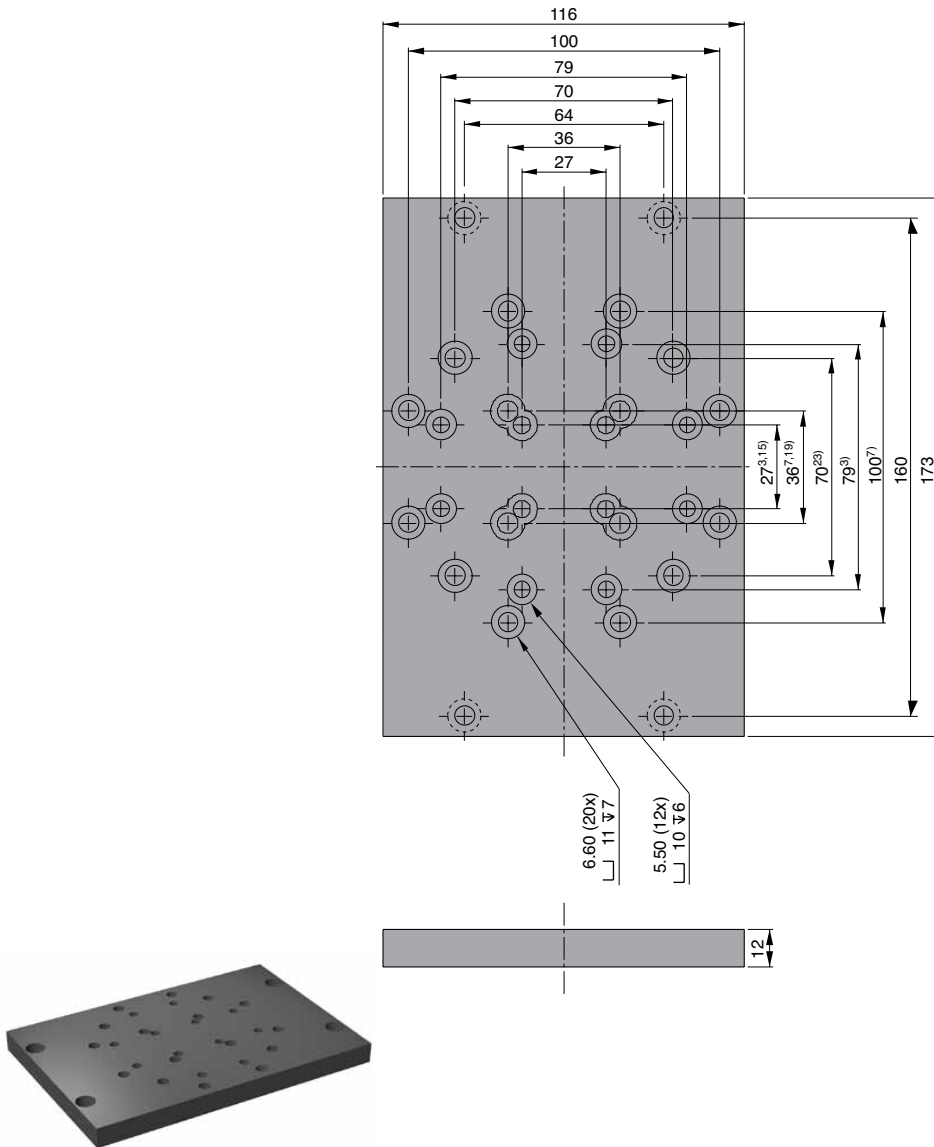

Dimensions with superscript values refer to the corresponding available options detailed on page 180. E.g. dimensions with superscript number 5 correspond to the option "C" for OSP-E32BHD actuator.

Order Instructions and Weight

Description	Weight (mass) [kg]	Order No.
Adapter Plate Type MA2-25	0,6	12270FIL

Linear Actuators see page 11 ff, 27 ff, 39 ff, 43 ff, 53 ff, 67 ff, 79 ff



P-A4P017GB

OSP-E

Adapter Plate

Dimensions [mm] Adapter Plate OSP-E 25/OSP-E32 Type: MA2-32

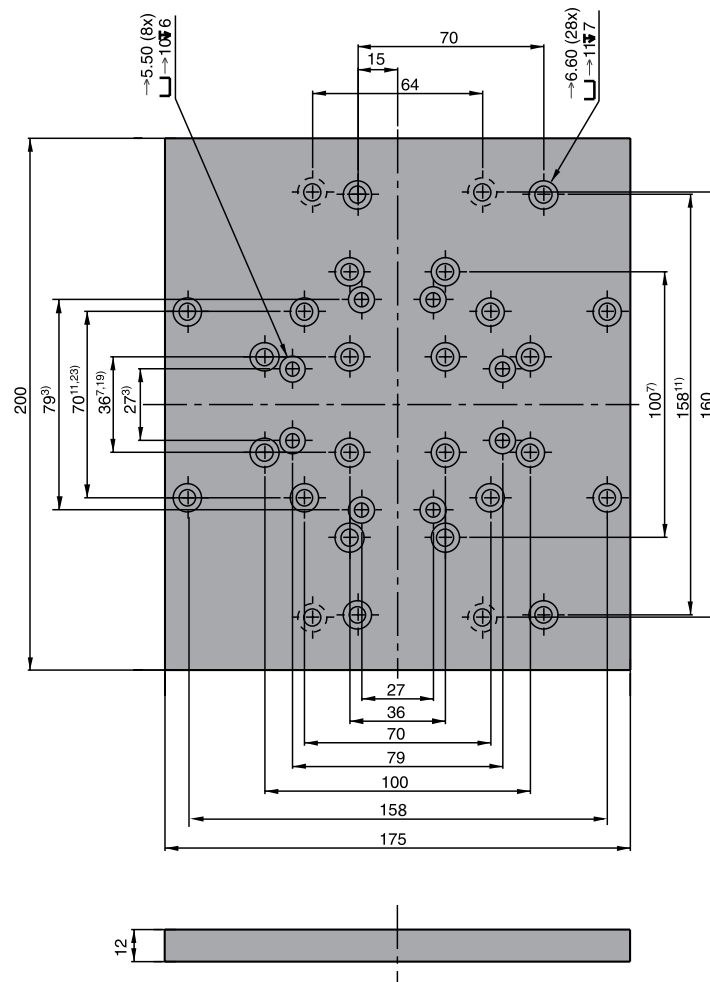

Dimensions with superscript values refer to the corresponding available options detailed on page 180. E. g. Dimensions with superscript number 5 correspond to the option "E" for OSP-E32BHD actuator.

Order Instructions and Weight

Description	Weight (mass) [kg]	Order No.
Adapter Plate Type MA2-32	1.1	12273FIL

Linear Actuators see page 11 ff, 27 ff, 39 ff, 43 ff, 53 ff, 67 ff, 79 ff



P-A4P017GB

OSP-E

Adapter Plate

Dimensions [mm] Adapter Plate OSP-E 50, Type: MA2-50

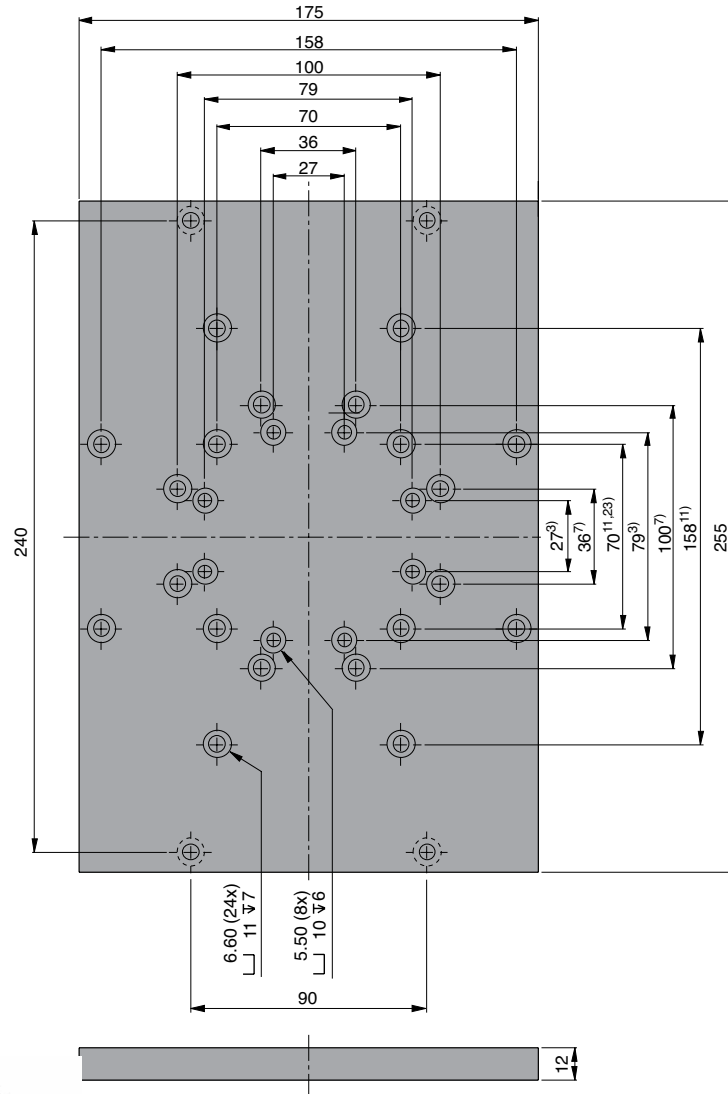

Dimensions with superscript values refer to the corresponding available options detailed on page 180. E.g. dimensions with superscript number 5 correspond to the option "E" for OSP-E32BHD actuator.

Order Instructions and Weight

Description	Weight (mass) [kg]	Order No.
Adapter Plate Type MA2-50	1.4	12276FIL

Linear Actuators see page 11 ff, 27 ff, 39 ff, 43 ff, 53 ff, 67 ff, 79 ff



P-A4P017GB

OSP-E

Adapter Plate

Dimensions [mm] Adapter Plate OSP-E 50, Type: MA3-25

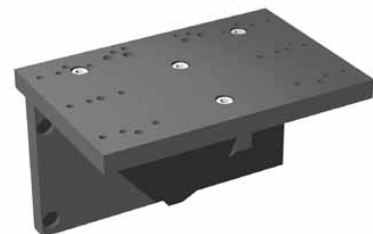
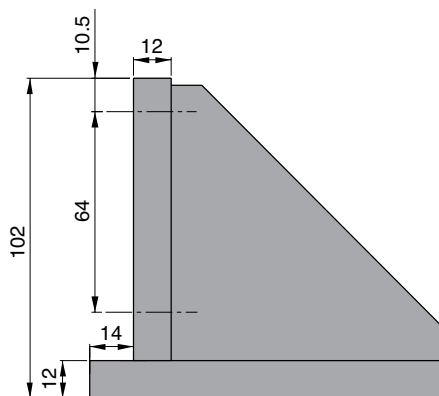
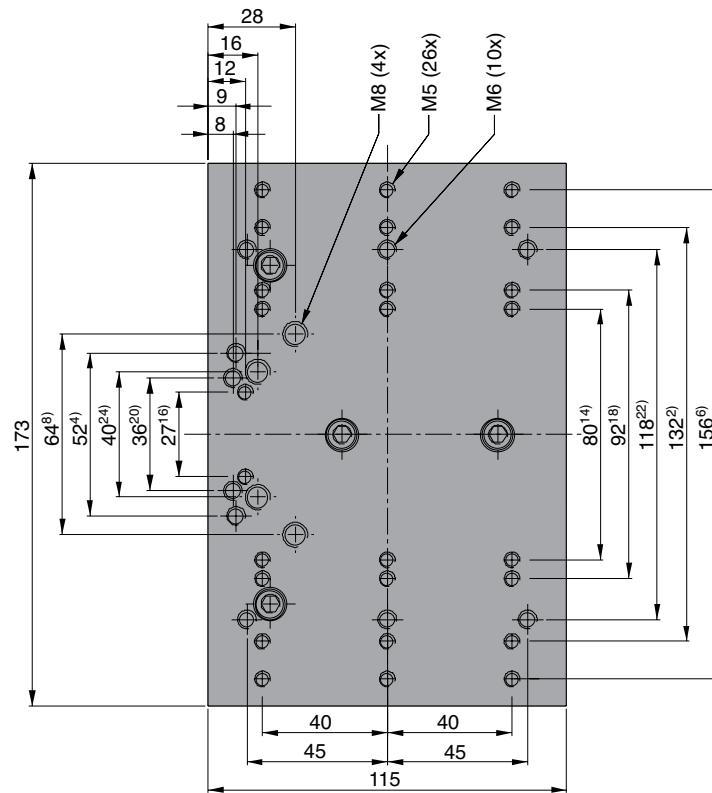

Dimensions with superscript values refer to the corresponding available options detailed on page 180. E. g. dimensions with superscript number 5 correspond to the option "EM" for OSP-E32BHD actuator.

Order Instructions and Weight

Description	Weight (mass) [kg]	Order No.
Adapter Plate Type MA3-25	1.3	12271FIL

Linear Actuators see page 11 ff, 27 ff, 39 ff, 43 ff, 53 ff, 67 ff, 79 ff



P-A4P017GB

OSP-E

Adapter Plate

Dimensions [mm] Adapter Plate OSP-E 32, Type: MA3-32

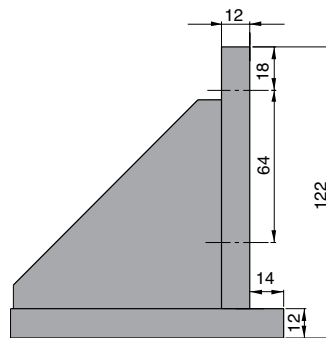
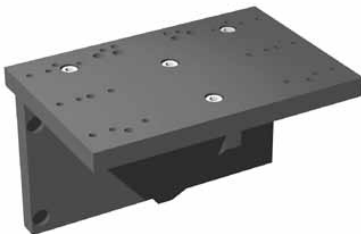
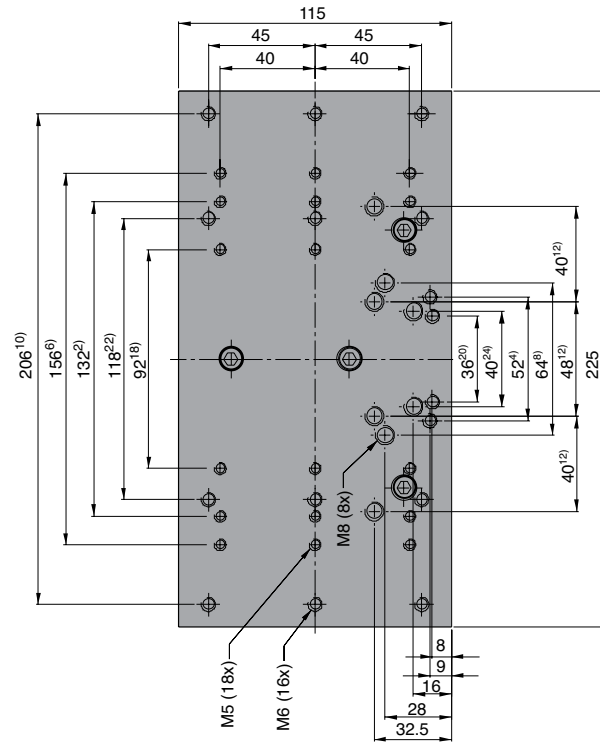

Dimensions with superscript values refer to the corresponding available options detailed on page 180. E.g. dimensions with superscript number 5 correspond to the option "EM" for OSP-E32BHD actuator.

Order Instructions and Weight

Description	Weight (mass) [kg]	Order No.
Adapter Plate Type MA3-32	1.8	12274FIL

Linear Actuators see page 11 ff, 27 ff, 39 ff, 43 ff, 53 ff, 67 ff, 79 ff



P-A4P017GB

OSP-E

Adapter Plate

Dimensions [mm] Adapter Plate OSP-E 50, Type: MA3-50

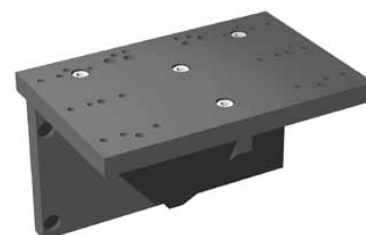
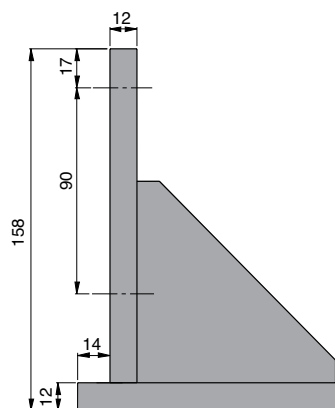
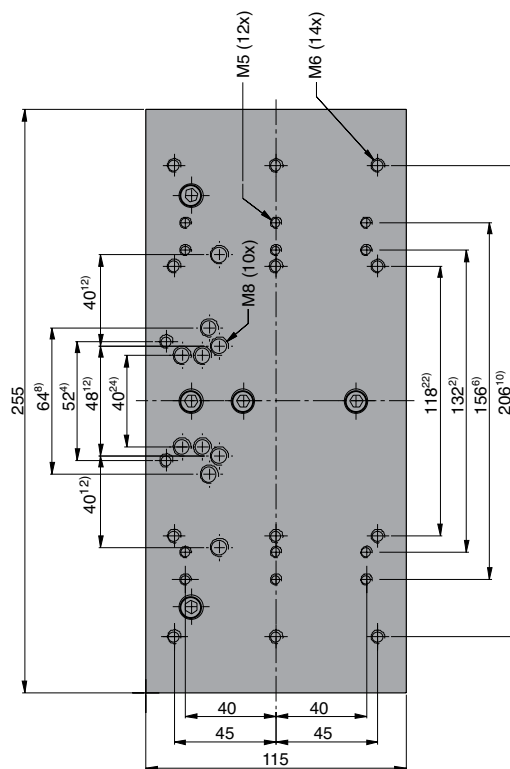

Dimensions with superscript values refer to the corresponding available options detailed on page 180. E.g. dimensions with superscript number 4 correspond to the option "EM" for OSP-E25BHD actuator.

Order Instructions and Weight

Description	Weight (mass) [kg]	Order No.
Adapter Plate Type MA3-50	2.3	12277FIL

Linear Actuators see page 11 ff, 27 ff, 39 ff, 43 ff, 53 ff, 67 ff, 79 ff



P-A4P017GB

OSP-E

Multi-Axis-System

Complete Intermediate Drive Shaft - Size 20, 25, 32, 50

for Actuator Series OSP-E..BHD

Note: For Series OSP-E..BHD with integrated gearbox, please contact your local Parker technical support.

Material:

Aluminium (AL-H) / Steel St-H)
Polyurethane/Hytrel

Features:

- Backlash-free shaft connection under pre-stress
- Design up to speed 1500 rpm
- Intermediate Drive Shaft with Double Coupling for Larger Displacements of Parallel Actuators
- Easy to Mount

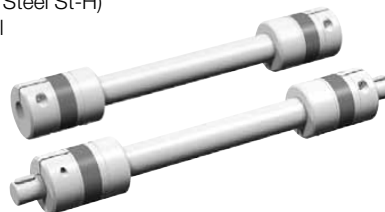

Intermediate Drive Shaft with Clamp Shaft Series OSP-E25BHD to E50BHD, Type MAS-..

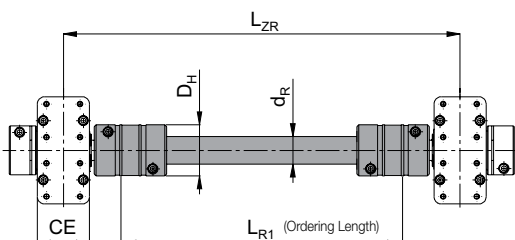

Intermediate Drive Shaft with Plain Shaft and Keyway Series OSP-E25BHD to E50BHD, Type MAS-..

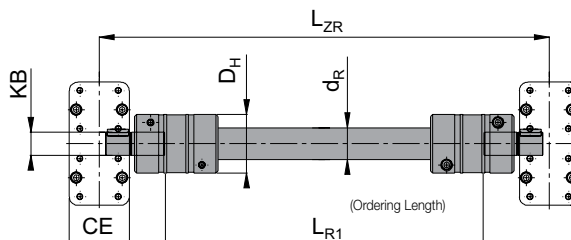

Critical Speed v. for Coupling Length

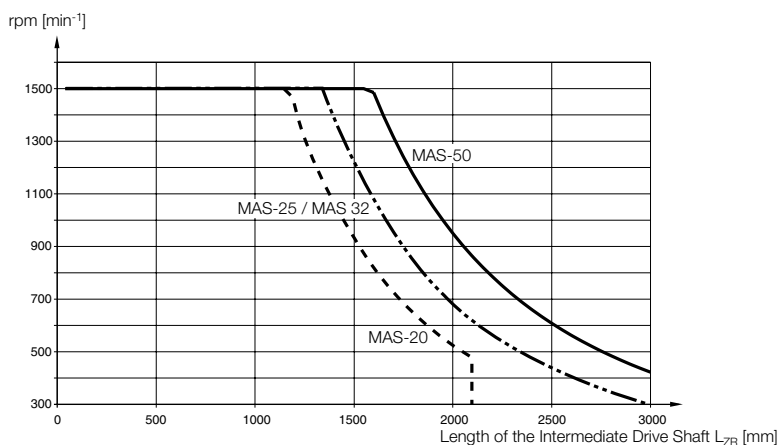

Characteristics / Dimension [mm] and Order Instructions

Series	Type	Max. Torque [Nm] **	CE	DH	KB***	LZR	LRI	dR	Order No. *	
									for clamp shaft	for hollow shaft
OSP-E20BHD	MAS-20	28	38	40	12 _{k6}	< 2100	L _{ZR} - 98	20 x 3,0	16256 - ...	16257 - ...
OSP-E25BHD	MAS-25	39	42	55	16 _{k6}	< 3000	L _{ZR} - 112	25 x 2,5	12305 - ...	12281 - ...
OSP-E32BHD	MAS-32	42	56	55	22 _{k6}	< 3000	L _{ZR} - 126	25 x 2,5	12306 - ...	12282 - ...
OSP-E50BHD	MAS-50	102	87	65	32 _{k6}	< 3000	L _{ZR} - 167	35 x 4,0	12307 - ...	12283 - ...

* Complete with L_{R1} in mm. Example: 12305 - 1200 (Length L_{R1} = 1200 mm)

** For higher torque requirement, please contact your local Parker technical support

*** Other dimensions for KB on request.



P-A4P017GB

OSP-E

Multi-Axis-System

Mounting Dimensions for Motor and Gears

Code	Description	A	B*	D	E	F	G
for motor and gears with clearance mounting holes							
A0	SY563T	66.50	M4	38.10	2.50	6.35	21.00
A1	SY873T	99.00	M6	73.00	3.00	9.52	31.50
A2	SMx60 xx xxx 8 11 ...	63.00	M5	40.00	2.50	11.00	23.00
A3	SMx82 xx xx 8 14 ...	100.00	M6	80.00	3.50	14.00	30.00
A4	SMx100 xx xx 5 19...	115.00	M8	95.00	3.50	19.00	40.00
A5	SMx115 xx xx 5 24... / SMx142 xx xx 5 24...	165.00	M10	130.00	3.50	24.00	50.00
A6	SMx115 xx xx 5 28... / SMx142 xx xx 5 28...	165.00	M10	130.00	3.50	28.00	60.00
A7	PS60	70.00	M5	50.00	11.00	16.00	40.00
A8	PS90	100.00	M6	80.00	15.00	22.00	52.00
A9	PS115	130.00	M8	110.00	16.00	32.00	68.00
for gears with threaded mounting holes							
C0	LP050 / PV40-TA	44.00	S4	35.00	6.50	12.00	24.50
C1	LP070 / PV60-TA	62.00	S5	52.00	8.00	16.00	36.00
C2	LP090 / PV90-TA	80.00	S6	68.00	10.00	22.00	46.00
C3	LP120	108.00	S8	90.00	12.00	32.00	70.00

* size of thread (e.g. M4) or counter bore (e.g. S4) used to mount motor or gear to the flange plate

P-A4P017GB

OSP-E

Parker Worldwide

Europe, Middle East, Africa

AE – United Arab Emirates, Dubai

Tel: +971 4 8127100
parker.me@parker.com

AT – Austria, Wiener Neustadt

Tel: +43 (0)2622 23501-0
parker.austria@parker.com

AT – Eastern Europe, Wiener Neustadt

Tel: +43 (0)2622 23501 900
parker.easteurope@parker.com

AZ – Azerbaijan, Baku

Tel: +994 50 2233 458
parker.azerbaijan@parker.com

BE/LU – Belgium, Nivelles

Tel: +32 (0)67 280 900
parker.belgium@parker.com

BY – Belarus, Minsk

Tel: +375 17 209 9399
parker.belarus@parker.com

CH – Switzerland, Etoy

Tel: +41 (0)21 821 87 00
parker.switzerland@parker.com

CZ – Czech Republic, Klecany

Tel: +420 284 083 111
parker.czechrepublic@parker.com

DE – Germany, Kaarst

Tel: +49 (0)2131 4016 0
parker.germany@parker.com

DK – Denmark, Ballerup

Tel: +45 43 56 04 00
parker.denmark@parker.com

ES – Spain, Madrid

Tel: +34 902 330 001
parker.spain@parker.com

FI – Finland, Vantaa

Tel: +358 (0)20 753 2500
parker.finland@parker.com

FR – France, Contamine s/Arve

Tel: +33 (0)4 50 25 80 25
parker.france@parker.com

GR – Greece, Athens

Tel: +30 210 933 6450
parker.greece@parker.com

HU – Hungary, Budapest

Tel: +36 1 220 4155
parker.hungary@parker.com

IE – Ireland, Dublin

Tel: +353 (0)1 466 6370
parker.ireland@parker.com

IT – Italy, Corsico (MI)

Tel: +39 02 45 19 21
parker.italy@parker.com

KZ – Kazakhstan, Almaty

Tel: +7 7272 505 800
parker.easteurope@parker.com

NL – The Netherlands, Oldenzaal

Tel: +31 (0)541 585 000
parker.nl@parker.com

NO – Norway, Asker

Tel: +47 66 75 34 00
parker.norway@parker.com

PL – Poland, Warsaw

Tel: +48 (0)22 573 24 00
parker.poland@parker.com

PT – Portugal, Leca da Palmeira

Tel: +351 22 999 7360
parker.portugal@parker.com

RO – Romania, Bucharest

Tel: +40 21 252 1382
parker.romania@parker.com

RU – Russia, Moscow

Tel: +7 495 645-2156
parker.russia@parker.com

SE – Sweden, Spånga

Tel: +46 (0)8 59 79 50 00
parker.sweden@parker.com

SK – Slovakia, Banská Bystrica

Tel: +421 484 162 252
parker.slovakia@parker.com

SL – Slovenia, Novo Mesto

Tel: +386 7 337 6650
parker.slovenia@parker.com

TR – Turkey, Istanbul

Tel: +90 216 4997081
parker.turkey@parker.com

UA – Ukraine, Kiev

Tel: +380 44 494 2731
parker.ukraine@parker.com

UK – United Kingdom, Warwick

Tel: +44 (0)1926 317 878
parker.uk@parker.com

ZA – South Africa, Kempton Park

Tel: +27 (0)11 961 0700
parker.southafrica@parker.com

North America

CA – Canada, Milton, Ontario

Tel: +1 905 693 3000

US – USA, Cleveland

Tel: +1 216 896 3000

Asia Pacific

AU – Australia, Castle Hill

Tel: +61 (0)2-9634 7777

CN – China, Shanghai

Tel: +86 21 2899 5000

HK – Hong Kong

Tel: +852 2428 8008

IN – India, Mumbai

Tel: +91 22 6513 7081-85

JP – Japan, Tokyo

Tel: +81 (0)3 6408 3901

KR – South Korea, Seoul

Tel: +82 2 559 0400

MY – Malaysia, Shah Alam

Tel: +60 3 7849 0800

NZ – New Zealand, Mt Wellington

Tel: +64 9 574 1744

SG – Singapore

Tel: +65 6887 6300

TH – Thailand, Bangkok

Tel: +662 717 8140

TW – Taiwan, Taipei

Tel: +886 2 2298 8987

South America

AR – Argentina, Buenos Aires

Tel: +54 3327 44 4129

BR – Brazil, Sao Jose dos Campos

Tel: +55 12 4009 3500

CL – Chile, Santiago

Tel: +56 2 623 1216

MX – Mexico, Apodaca

Tel: +52 81 8156 6000

VE – Venezuela, Caracas

Tel: +58 212 238 5422

Parker Hannifin GmbH

Pat-Parker-Platz 1
D-41564 Kaarst (Germany)

Tel: +49 2131 4016-0

Fax: +49 2131 4016-9199

E-Mail: parker.germany@parker.com

Internet: www.parker.com, www.parker-origa.com

