

aerospace  
climate control  
**electromechanical**  
filtration  
fluid & gas handling  
hydraulics  
pneumatics  
process control  
sealing & shielding



## Parker Automation Controller

Intelligent Multi-Axis Motion Controller



ENGINEERING YOUR SUCCESS.



**WARNING – USER RESPONSIBILITY**

**FAILURE OR IMPROPER SELECTION OR IMPROPER USE OF THE PRODUCTS DESCRIBED HEREIN OR RELATED ITEMS CAN CAUSE DEATH, PERSONAL INJURY AND PROPERTY DAMAGE.**

- This document and other information from Parker-Hannifin Corporation, its subsidiaries and authorized distributors provide product or system options for further investigation by users having technical expertise.
- The user, through its own analysis and testing, is solely responsible for making the final selection of the system and components and assuring that all performance, endurance, maintenance, safety and warning requirements of the application are met. The user must analyze all aspects of the application, follow applicable industry standards, and follow the information concerning the product in the current product catalog and in any other materials provided from Parker or its subsidiaries or authorized distributors.
- To the extent that Parker or its subsidiaries or authorized distributors provide component or system options based upon data or specifications provided by the user, the user is responsible for determining that such data and specifications are suitable and sufficient for all applications and reasonably foreseeable uses of the components or systems.

## Parker Automation Controller - PAC

<b>Overview</b> .....	<b>5</b>
<b>Product Overview</b> .....	<b>6</b>
<b>Technical Characteristics</b> .....	<b>8</b>
Technical Data .....	8
Standards and Conformance .....	8
Dimensions .....	9
<b>Accessories and Options</b> .....	<b>10</b>
PAC Terminal .....	10
Communication Modules .....	12
Parker Automation Controller I/O Modules .....	12
Software - Parker Automation Manager .....	13
Control Network Architecture .....	14
<b>Related Products</b> .....	<b>15</b>
Parker Servo Drive (PSD) .....	15
Brushless servo motors .....	15
Handling actuators .....	15
<b>Order Code</b> .....	<b>16</b>
Parker Automation Controller .....	16
PAC Terminal .....	17

# Parker Hannifin

## The global leader in motion and control technologies

### A world class player on a local stage

#### Global Product Design

Parker Hannifin has more than 40 years experience in the design and manufacturing of drives, controls, motors and mechanical products. With dedicated global product development teams, Parker draws on industry-leading technological leadership and experience from engineering teams in Europe, North America and Asia.

#### Local Application Expertise

Parker has local engineering resources committed to adapting and applying our current products and technologies to best fit our customers' needs.

#### Manufacturing to Meet Our Customers' Needs

Parker is committed to meeting the increasing service demands that our customers require to succeed in the global industrial market. Parker's manufacturing teams seek continuous improvement through the implementation of lean manufacturing methods throughout the process. We measure ourselves on meeting our customers' expectations of quality and delivery, not just our own. In order to meet these expectations, Parker operates and continues to invest in our manufacturing facilities in Europe, North America and Asia.

#### Electromechanical Worldwide Manufacturing Locations

##### Europe

Littlehampton, United Kingdom  
Dijon, France  
Offenburg, Germany  
Filderstadt, Germany  
Milan, Italy

##### Asia

Wuxi, China  
Jangan, Korea  
Chennai, India

##### North America

Rohnert Park, California  
Irwin, Pennsylvania  
Charlotte, North Carolina  
New Ulm, Minnesota



Offenburg, Germany

#### Local Manufacturing and Support in Europe

Parker provides sales assistance and local technical support through a network of dedicated sales teams and authorized technical distributors throughout Europe.

For contact information, please refer to the Sales Offices on the back cover of this document or visit [www.parker.com](http://www.parker.com)



Milan, Italy



Littlehampton, UK



Filderstadt, Germany



Dijon, France

# Parker Automation Controller - PAC

## Overview

### Description

Powerful, integrated, and designed for the global machine market, the EtherCAT based Parker Automation Controller (PAC) combines machine logic, real-time motion control and visualization into a standard based, performance driven, fan-less and easily mountable din rail solution. This programmable automation controller comes equipped with a native, real-time EtherCAT bus for high-speed I/O and motion control, a modular interface slot for 3rd Party device communication, standard Ethernet and USB ports plus onboard SD program storage. Programmed with the Parker Automation Manager software, OEMs can produce efficient, high-performance control systems based on the IEC61131-3 and PLCopen Motion standards.

The motion controller's solid state design is precisely engineered for demanding industrial environments. The powerful, yet energy efficient Intel® Atom™ N2600 processor allows for fanless operation while supporting dual-cores, 64-bit instructions, and Hyper-threading technology. Coupled with the removable, solid state SD storage media, all moving parts have been eliminated for a robust, industrial grade control solution.

### Features

- IEC61131-3 programming
- PLCopen motion control
- Simulation runtime
- High-speed EtherCAT
- Dual Ethernet networks
- Local and remote I/O
- SD application memory
- Modular communication interface
- Intel® N2600 dual core, 1.60 GHz, 64bit
- 1 GB DDR3 SDRAM
- Fan-less operation
- CNC capability
- DIN rail mounted
- Web configuration tool



### Technical Characteristics - Overview

Parker Automation Controller - PAC	
Supply voltage	24 VDC -15 %/+25 %
CPU	Intel® N2600 CPU, 1.6 GHz, Dual Core, 64bit 1 MB L2 Cache
Memory	Up to 1 GB SDRAM
Storage	2 GB
Ports	2x RJ-45 10/100/1000BaseT Ethernet 1x RJ45 100Mbit/s EtherCAT supporting IEEE1588 distributed clocks 2x USB 2.0 Host Type A
Storage temperature	-25...+70 °C
Operating temperature	0...+50 °C
Relative humidity	5...95 %, non-condensing
Built-in fieldbus	EtherCAT 100 Mbit/s
Dimensions	25x120x90 mm (WxHxD)
Shielding	Connected straight to module housing
Installation	35 mm DIN rail (top-hat rail)
Protection	IP20
CE Compliant	2004/108/EC Electromagnetic Compatibility
UL	UL508 & UL61010-1 / UL61010-2-201

## Product Overview Parker Automation Controller

Designed for OEMs to maximize efficiency while exceeding performance expectations, the Parker Automation Control System comprises the Parker Automation Controller (PAC), the Parker Automation Manager Integrated Development Environment (IDE), and the PAC I/O System. Together these elements provide OEMs with a powerful, standards-based programmable automation controller designed to tackle the most demanding applications. The PAC System consolidates machine logic, signal handling, advanced motion, and visualization into one performance driven solution, thus eliminating unnecessary hardware and communication links, and maximizing developer efficiency.

### I/O Modules



The PAC I/O System comprises a variety of modules for digital, analog, temperature signals, high-speed counters and communication interfaces.



#### SD storage

- SD card allows applications and data to be stored



PAC side



I/O side

#### E-Bus connector

- Provides fast EtherCAT connectivity for local PACIO Modules
- Vibration proofed connection



#### Push button

- IP address log button and clearing of the "ERROR" LED.



#### Intel® N2600 Dual Core Processor

- 1GB DDR3 SDRAM
- 64 bit instructions
- Fan-less Operation

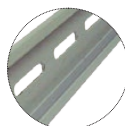

#### DIN rail mount

- Easy installation



#### Power connector

- Connector for input power, +24VDC nominal.

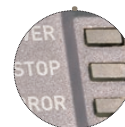

#### System status LEDs

- 3 LEDs indicate the system status



#### USB ports

- Dual standard USB 2.0 ports, type A





## Software - Parker Automation Manager

Designed specifically to meet the needs of OEMs, the Parker Automation Manager (PAM) provides tools for faster code generation, modular code reuse and decreased commissioning times and thus supports faster times to market, decreases development cost, and increases ROI.



Engineers can work smarter, more efficiently and more effectively by choosing from the five IEC standard programming languages to optimize for an application, by using industry standard PLCopen Motion for motion control programming, deploying to the powerful simulation runtime for faster development and using online variable watch and trending for logic analysis.

Parker Automation Manager puts the engineer first and provides all the tools to make control programming smart and efficient.

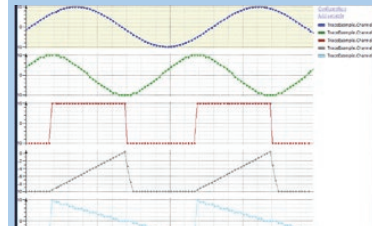

- IEC61131-3 programming
- PLCopen motion control
- Simulation runtime
- Web configuration tool
- Advanced Cam Editor
- CNC capability
- PLCopen motion control I, II, III

## Technical Characteristics

### Technical Data

<b>Input voltage</b>	24 VDC (-15 %/+25 %), SELV limited energy, 1.2 A, 29 W Power must be provided by a class 2 power source. Overvoltage category 1
<b>CPU</b>	Intel® N2600 CPU, 1.6 GHz, Dual Core, 64bit, 1 MB L2 Cache
<b>Memory</b>	Up to 1 GB DDR3 SDRAM (minimum), 1066 MHz, PC3-8500, 204-pin SODIMM Socket
<b>Storage</b>	2 GB (minimum) Secure Digital Card (SD)
<b>Fuse</b>	Littelfuse Nano SMF slow blow type; part number R454002
<b>Heat dissipation</b>	Without optional communications module: 5.0 W maximum With optional communications module: 5.8 W maximum
<b>Maximum number of PACIO modules</b>	Up to 20 modules connected to the controller or, maximum 5 VDC @3 A E-bus load. More than 20 modules can be added to the PAC320 by using the extender module and bus coupler module. See the PACIO bus coupler section of the user guide
<b>Electrical insulation</b>	Modules electrically insulated from one another and from the bus
<b>IO connection</b>	Spring-assisted combi plug with mechanical ejector, 4...36 pin
<b>Diagnosis indication</b>	LED located next to the terminal LED: bus state, module state, broken wire/excessive current
<b>Number of ports</b>	Up to 32 digital I/Os on every module, up to 8 analog channels per module
<b>Noise immunity</b>	Zone B to EN 61131-2, installation on an earthed top at DIN rail in the earthed control cabinet
<b>Shock rating</b>	10 g peak; 11 ms (operating) 30 g peak; 11 ms (non-operating)
<b>Operating vibration</b>	10...500 Hz: 2 grms random
<b>Altitude</b>	3048 m (10000 Feet)

### Standards and Conformance

Tests	Specification
Harmonic current emissions	EN 61000-3-2:2006 + A2:2009 IEC 61000-3-2:2009
Voltage fluctuations and flicker	EN 61000-3-3:2008 IEC 61000-3-3:2008
Electrostatic discharge immunity	IEC 61000-4-2:2008
Radiated electromagnetic field immunity	IEC 61000-4-3:2010
Electrical fast transient burst immunity	IEC 61000-4-4:2012
Surge immunity	IEC 61000-4-5:2005
Radio frequency common mode immunity	IEC 61000-4-6:2008
Power frequency magnetic field immunity	IEC 61000-4-8:2009
Voltage interrupts immunity	IEC 61000-4-11:2004
Radiated & conducted emissions	EN 55011:2009 + A1:2010
CISPR 11 Group 1, Class A	CISPR 11:2009 + A1:2010
EN61010-1:2010	Safety Requirements for Electrical Equipment for Measurement, Control and Laboratory use. Part 1 General Requirements
EN61010-2-201:2013	Safety Requirements for Electrical Equipment for Measurement, Control and Laboratory use. Part 2-201 Particular Requirements for Control Equipment
UL 61010-1, 3rd Edition, 2012-04-17 UL File E243373	Electrical Equipment for Measurement, Control and Laboratory use. Part 1: General Requirements
CAN/CSA-C22.2 No. 61010-1, 3rd Edition, 2012-04	Electrical Equipment for Measurement, Control and Laboratory use. Part 1: General Requirements
UL 61010-2-201	Safety requirements for electrical equipment for measurement, control, and laboratory use, Part 2-201: Particular requirements for control equipment
IEC 60529, Edition 2.1 + Corr. 1:2003 + Corr. 2:2007 + Corr. 3:2009	Protection Degree IP20

## Dimensions

### Parker Automation Controller Dimensions

Dimensions [mm]

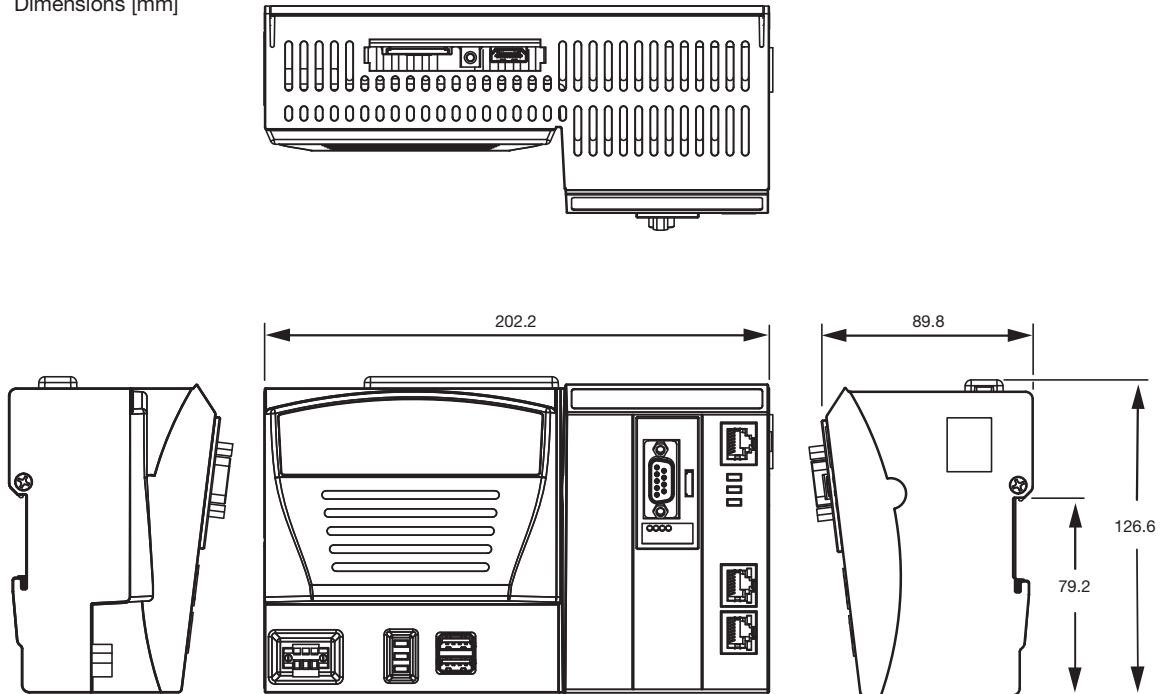

### I/O Dimensions

Dimensions [mm]

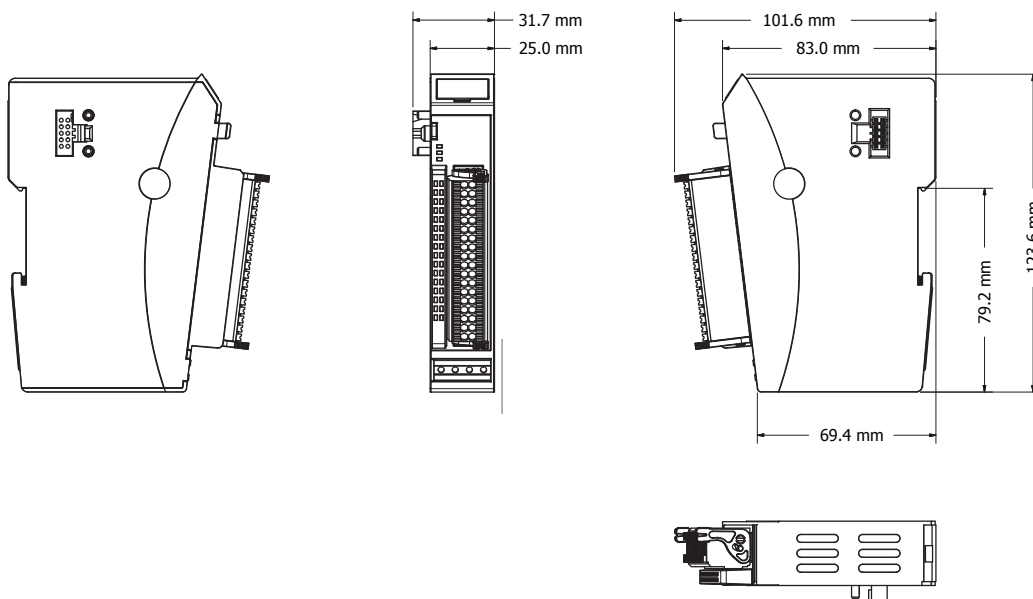

## Accessories and Options

### PAC Terminal

The PT displays any embedded HMI option from the PAC to its screen allowing the full HMI experience with half the cost

The PAC Terminal is a thin-client HMI that has been designed from the start to offer the easiest configuration and connection in the industry. The PAC (Parker Automation Controller) hosts either an embedded Xpress or Web Visualization application, while the PT displays the target visualization and transfers the users touch input commands back to the PAC.

#### Reduce HMI Hardware Costs

Our PAC controller does the heavy lifting hosting the HMI application, allowing the PAC Terminal to provide high end HMI performance at very cost effective pricing.

#### Reduced Development Time

Embedded Xpress provides intuitive, drag and drop tools for developing HMI applications that can reduce your development time by 30% over competing toolsets.

Users who prefer IEC 61131-3 programming can quickly tie their PAC programming logic to Web Visualization objects for a seamless logical solution.

#### Reduce Downtime

The PAC Terminal is essentially a Web browser designed for the factory floor. If for any reason, the PAC Terminal stops functioning, the PAC controller can publish its screen to any device with a compatible Web browser and your process keeps running. Better yet, simply replace the PAC Terminal and set IP addresses and your application is back running, no application to load, no other configuration required.

#### Increasing Security

The PAC Terminal contains no application data when disconnected from the PAC controller. Critical application data, parameters and history are all stored on the PAC, safely in your main control cabinet. This centralized architecture presents an inherently smaller attack profile for malware, viruses and other malicious intent as your HMI is no longer an intelligent device containing critical information — yet, no functionality is compromised.



Part number	PTA/L-007	PTA-010	PTA-015
Size	7"	10.1"	15.6"
Display	Resolution	800 x 480	1280 x 800
	Viewing Angle	140(H) / 120(V)	170(H) / 170(V)
	Brightness	350 cd/m2	350 cd/m2
	Bulb Life (hrs)	40,000	25,000
Weight (kg)	1 / 0.8	1.8	4.5
Touch Interface	Analog Resistive		
Supply Voltage	12/24 VDC		
Power input	13W	14W	20W
HMI Software	Android running PAC Terminal App		
Processor & RAM	1 GHz Freescale iMX6		
SD Storage	4 GB eMMC		
USB	(2) USB 2.0, Type A		
Ethernet	(1) 1000 Base-T, RJ45		
Environment	Operating Temp	0 – 50°C	
	Rel. Humidity	10-90% @ 40°C, non-condensing	
	Vibration	5-500 Hz: 1 Grms random	
	Shock	15 G peak @ 11 msec	
IP Rating	IP65 Front Bezel		

## Dimensions

### PTA/L-007

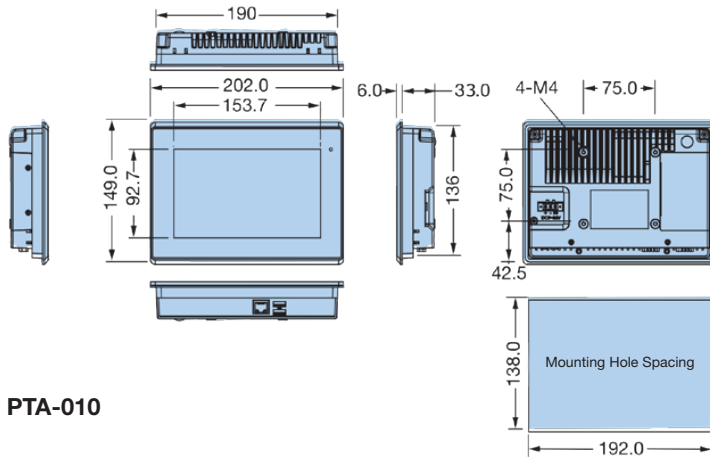

### PTA-010

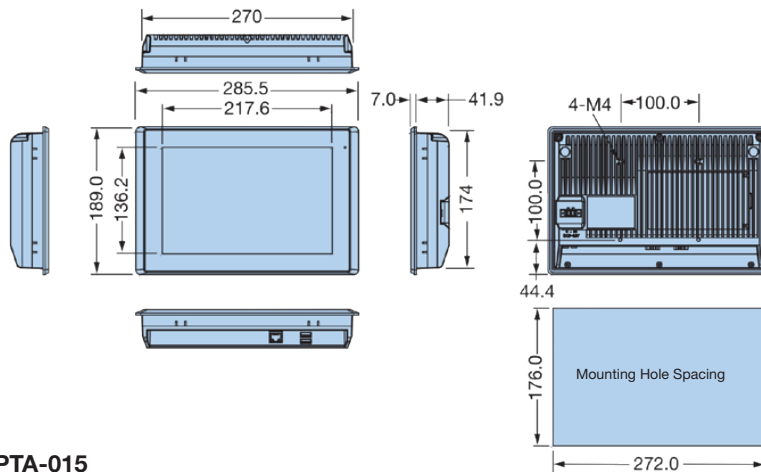

### PTA-015

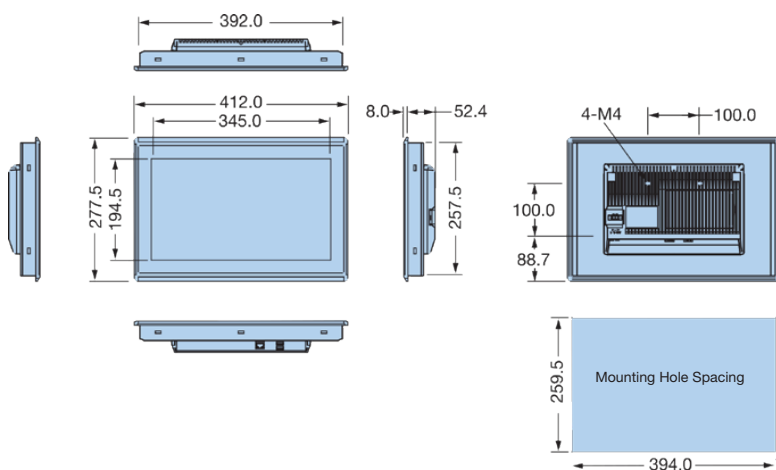

## Communication Modules

The Parker Automation Controller (PAC) comes standard with the industry leading high-speed EtherCAT communication bus for motion, I/O, and 3rd party device connectivity.

Coupled with the standard modular communication interface, dual LAN capability, and ability to integrate directly into Ethernet/IP networks (Modbus TCP is also available), the PAC provides unprecedented connectivity for complimentary devices and network isolation for IT professionals.

The following communication protocols are available:

- EtherCAT
- PROFINET
- Ethernet/IP
- Modbus TCP (Master & Slave as a standard on every unit)



PROFINET communication module

## Parker Automation Controller I/O Modules

The PAC I/O System comprises a variety of modules for digital, analog and temperature signals as well as communication interfaces. The modules connect directly to the controller via the built-in EtherCAT bus for local architectures and are extended to remote locations via the extender and bus coupler modules, thus supporting both local and distributed I/O architectures.

PAC I/O modules feature a removable cage-clamp terminal design which provides for easy wiring and assembly and allows for the removal and insertion of modules without interfering with wiring; LED status indicators for the EtherCAT bus, I/O, power and each signal channel; front-face shield-grounding to the din-rail; removable label inserts; easy access front mounted module disconnects; and laser etched identification and schematic information.

PAC I/O communicates natively on the EtherCAT bus and is unencumbered by protocol converters; therefore it provides the full functionality and throughput of high-speed EtherCAT to meet the most demanding I/O requirements.



Module Type	Part Number	PACIO Description
<b>Bus Coupler</b>	PACIO-400-00	PACIO EtherCAT Bus coupler, 3 A
<b>Digital I/O Modules</b>	PACIO-450-02	PACIO DI16/DO8 (16 inputs/8 outputs), 1 A
	PACIO-450-03	PACIO DI16/DO16 (16 inputs/16 outputs), 1 ms delay, 0.5 A
	PACIO-450-13	PACIO DI16/DO16 (16 inputs/16 outputs), 1 ms delay, 0.5 A Low-side
	PACIO-451-02	PACIO DI32 (32 inputs), 1 ms delay
	PACIO-451-03	PACIO DI16 (16 inputs), 1 ms delay
	PACIO-450-05	PACIO DI8/DO8 (8 inputs/8 outputs), 1 ms delay, 0.5 A
	PACIO-452-01	PACIO DO16 (16 outputs), 0.5 A
	PACIO-452-02	PACIO DO8 (8 outputs)1 A
<b>Analog</b>	PACIO-441-01	PACIO AI4-mA (4 single-ended analog input module), 12 Bit resolution
	PACIO-441-02	PACIO AI4/8-VDC (4 differential/8 single-ended analog input module), 13 Bit
	PACIO-442-02	PACIO AO4-VDC/mA (4 analog output module), 12 Bit resolution
<b>Temperature</b>	PACIO-443-01	PACIO AI4-Pt/Ni100 (4 analog inputs, 70 to 300 ohm resistance), 16 Bit
	PACIO-443-03	PACIO AI4-Pt/Ni1000 (4 analog inputs, 70 to 3000 ohm resistance), 16 Bit
<b>Counter</b>	PACIO-454-01	PACIO Counter/Enc (encoder counter module)
<b>Interfaces</b>	PACIO-400-02	PACIO Extender 2 Port (EtherCAT I/O extender)
<b>Accessories</b>	PACIO-412-01	PACIO Shield 2x8 mm
	PACIO-412-02	PACIO Shield 14 mm
	PACIO-411-00	Power Distribution Module (distributes 0 VDC or 24 VDC attached at pins L1 or L2)

## Software - Parker Automation Manager

Smart and powerful, Parker's Automation Manager is the single, integrated development environment for programming complex machine logic, signal handling, advanced motion, and visualization.

Engineers can now manage an entire product line in one project by simply configuring multiple hardware devices and application containers, deploying reusable software packages to specific application containers and then activating the appropriate application container to download to specific machines. This method allows OEMs to maintain their program files in one project and make code changes in one place to affect all versions of a particular machine. Thus machine builders now have a development platform specifically designed to support modular machines and valuable add-on software modules.

- Customizable Interface
- Powerful cam editor
- Alarm Configuration
- PAC-to-PAC Communication
- Recipe Manager
- Unit Conversion
- Web Visualization
- Retentive Variables

With Automation Manager, engineers can leverage their existing knowledge and work smarter, more efficient and more effective than ever with the full suite of IEC 61131 programming languages and Parts I, II and III of PLCopen Motion Control. This standards-based approach flattens the learning curve and provides a common platform for control engineers. The standard platform is complimented by Simulation Runtime for simulating logic and motion on the development computer for faster development and by a complete suite of debugging tools, including online variable watch, trending, logging and breakpoints for logic analysis. Automation Manager supports reusable, extensible software with package referencing and object oriented programming techniques, including methods to protect software



implementations and thus the intellectual property of OEMs. In short, Automation Manager is designed specifically for OEMs to decrease development and commissioning time; to support modular, reusable, extensible and protected code; and to provide engineers with the environment and tools necessary to create control applications for the complex, demanding machines of our time.

- IEC61131-3 programming languages
  - Ladder diagram
  - Structured text
  - Function block diagram
  - Sequential function chart
  - Instruction list
- PLCopen motion control I, II, III



- Simulation Runtime for code & motion
- Variable watch & trending
- Auto-declaration
- Smart coding auto-complete
- Breakpoint debugging
- Custom function/function block development
- CNC development
- DXF file import
- G-code generation

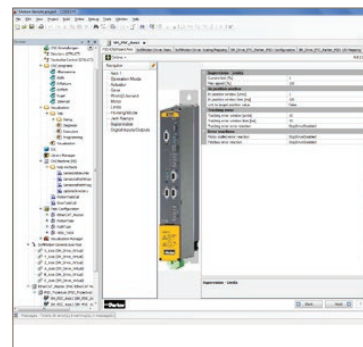

Programming

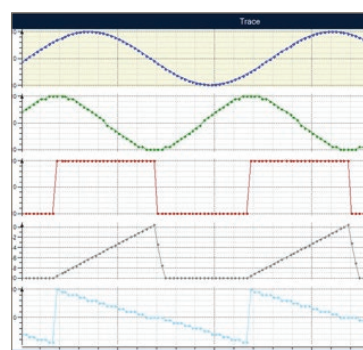

Trace / debugging

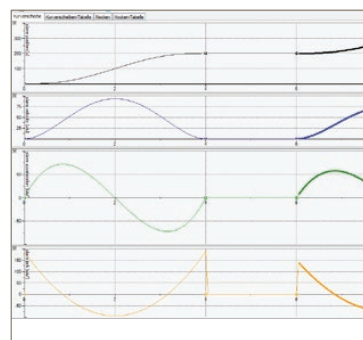

CAM Design

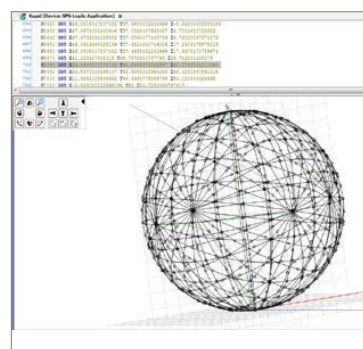

CNC Design

Parker Automation Controller - PAC  
Control Network Architecture

Control Network Architecture

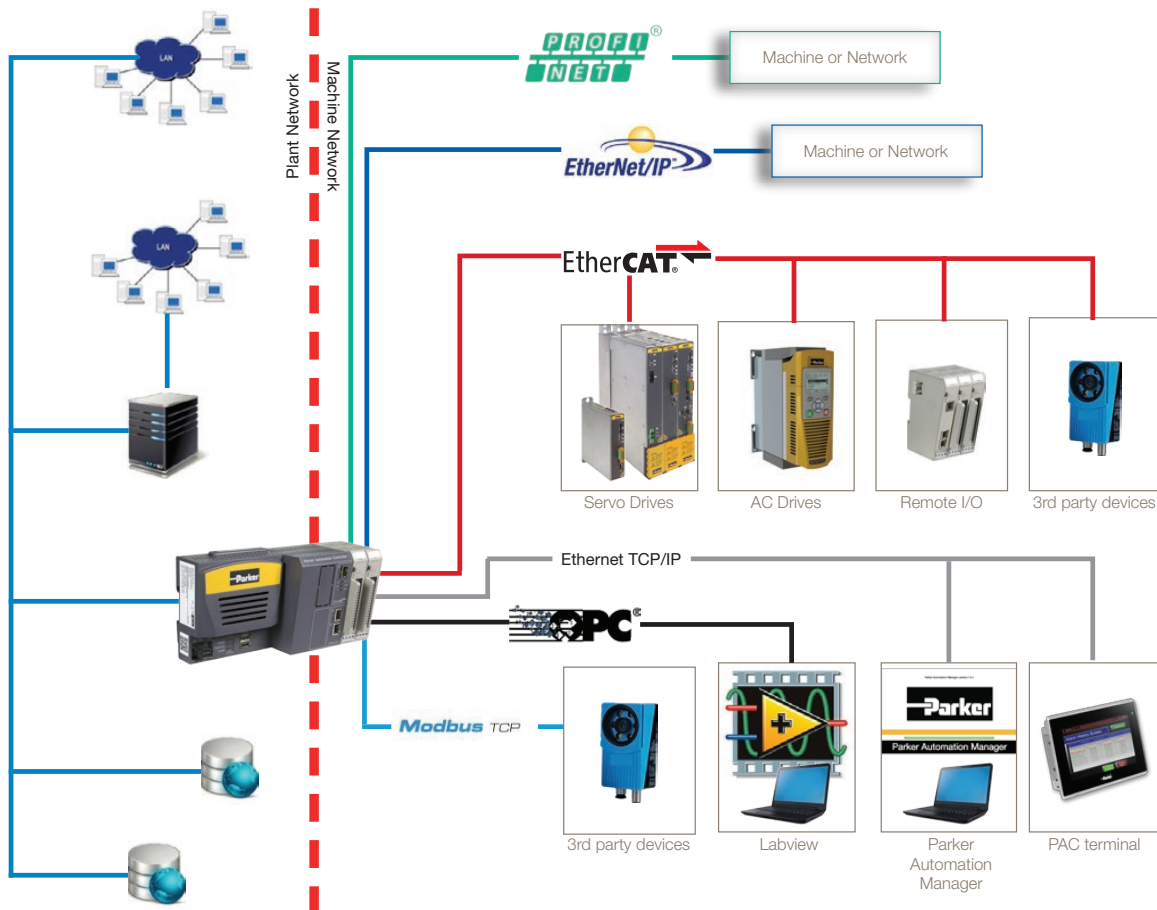

## Related Products

### Parker Servo Drive (PSD)

The PSD1 is Parker Servo Drive family available with different power rating and form factors. Today the offering contains:

The PSD1-S is the standalone version which can be connected directly to the main supply.

The PSD1-M is a multi-axis system where each power module can supply up to three servo motors. The base configuration consists of a common DC bus supply and multiples PSD1-M modules, connected through DC bus bars. The modules are available as one, two or three axis versions, this makes the system very flexible.

PSD1-M servo drive is particularly suitable for all centralised automation systems, such as those found in many packaging machines, where large numbers of drives are often required offering significant advantages.



### Brushless servo motors



The Single Cable Servo Drive System from Parker is based on the Hiperface DSL® digital feedback technology. The encoder feedback communication is fully integrated into the motor power cable and thus no separate feedback cable between drive and motor is required.

The feedback system is a purely digital encoder communication protocol with exceptional performance. The absolute position determination, a resolution of up to 20 bit per turn, as well as 4096 maximum rotations, is unique in its class. The System is a bespoke solution to provide machine builders with lower cabling and installation cost and the possibility to reduce control panel size and machine footprint.

### Handling actuators

All linear actuators offered by Parker Hannifin feature a modular and therefore flexible structure. They reflect Parker's long practical experience in the field of handling technology. In addition, we have developed special solutions for various applications, such as actuators suitable for clean-room applications as well as actuators for the food industry. The mechanical components can be combined to create multi-axis systems with the aid of a range of attachments and accessories. The user can choose between different versions including linear, vertical and telescopic actuators as well as electric cylinders. In addition, several different drive technologies are available including ballscrews, toothed belt drive, linear motor and a combination of toothed belt and toothed rack.



ETT - Electric tubular motor



ETH - High Force Electro Thrust Cylinder

Parker Automation Controller - PAC  
Order Code

## Order Code

### Parker Automation Controller

	1		2	3	4	5	6		7	8
Order example	<b>PAC320</b>	-	<b>M</b>	<b>W</b>	<b>N</b>	<b>2</b>	<b>1</b>	-	<b>3</b>	<b>A</b>

<b>1 Series</b>	<b>PAC320</b> Controller
<b>2 Software</b>	<b>C</b> IEC, PLCopen Motion, CNC <b>M</b> IEC, PLCopen Motion <b>P</b> IEC only
<b>3 Visualization</b>	<b>N</b> No Visualization <b>W</b> Web Visualization
<b>4 Communications Options</b>	<b>N</b> EtherCAT Protocol (standard) <b>E</b> EtherCAT + Ethernet/IP Protocol <b>P</b> EtherCAT + PROFINET Slave <b>B</b> EtherCAT + Ethernet/IP + PROFINET
<b>5 Retentive Memory</b>	<b>2</b> 256k Bytes
<b>6 Processor</b>	<b>1</b> 1.60 GHz Dual Core Intel® N2600
<b>7 Agency Approvals</b>	<b>3</b> UL/cUL/CE
<b>8 Reserved</b>	<b>A</b> Reserved

## PAC Terminal

	1	2		3		4	5	6	7	8
Order example	PT	A	-	015	-	1	R	-	1	3

<b>1 Series</b>	PT	PAC Terminal
<b>2 Bezel Type</b>	A	Aluminium
	L	Plastic (7" only)
<b>3 Size</b>	007	7" Touchscreen
	010	10" Touchscreen
	015	15" Touchscreen
<b>4 Processor</b>	1	iMX6 ARM
<b>5 Touch Options</b>	R	Analog resistive touch
<b>6 Storage</b>	1	4 GB eMMC
<b>7 Operating System</b>	1	Android w/PAC Term. App
<b>8 Agency Approvals</b>	3	CE, UL/cUL, IEC/EN61010
	5	Haz-Loc (Class 1 Div 2)





# Parker's Motion & Control Technologies

At Parker, we're guided by a relentless drive to help our customers become more productive and achieve higher levels of profitability by engineering the best systems for their requirements. It means looking at customer applications from many angles to find new ways to create value. Whatever the motion and control technology need, Parker has the experience, breadth of product and global reach to consistently deliver. No company knows more about motion and control technology than Parker. For further info call 00800 27 27 5374



## Aerospace

### Key Markets

Aftermarket services  
Commercial transports  
Engines  
General & business aviation  
Helicopters  
Launch vehicles  
Military aircraft  
Missiles  
Power generation  
Regional transports  
Unmanned aerial vehicles

### Key Products

Control systems & actuation products  
Engine systems & components  
Fluid conveyance systems & components  
Fluid metering, delivery & atomization devices  
Fuel systems & components  
Fuel tank inerting systems  
Hydraulic systems & components  
Thermal management  
Wheels & brakes



## Climate Control

### Key Markets

Agriculture  
Air conditioning  
Construction Machinery  
Food & beverage  
Industrial machinery  
Life sciences  
Oil & gas  
Precision cooling  
Process  
Refrigeration  
Transportation

### Key Products

Accumulators  
Advanced actuators  
CO<sub>2</sub> controls  
Electronic controllers  
Filter driers  
Hand shut-off valves  
Heat exchangers  
Hose & fittings  
Pressure regulating valves  
Refrigerant distributors  
Safety relief valves  
Smart pumps  
Solenoid valves  
Thermostatic expansion valves



## Electromechanical

### Key Markets

Aerospace  
Factory automation  
Life science & medical  
Machine tools  
Packaging machinery  
Paper machinery  
Oil & gas  
Primary metals  
Semiconductor & electronics  
Textile  
Wire & cable

### Key Products

AC/DC drives & systems  
Electric actuators, gantry robots & slides  
Electrohydraulic actuation systems  
Electromechanical actuation systems  
Human machine interface  
Linear motors  
Stepper motors, servo motors, drives & controls  
Structural extrusions



## Filtration

### Key Markets

Aerospace  
Food & beverage  
Industrial plant & equipment  
Life sciences  
Marine  
Mobile equipment  
Oil & gas  
Power generation & renewable energy  
Process  
Transportation  
Water Purification

### Key Products

Analytical gas generators  
Compressed air filters & dryers  
Engine air, coolant, fuel & oil filtration systems  
Fluid condition monitoring systems  
Hydraulic & lubrication filters  
Hydrogen, nitrogen & zero air generators  
Instrumentation filters  
Membrane & fiber filters  
Microfiltration  
Sterile air filtration  
Water desalination & purification filters & systems



## Fluid & Gas Handling

### Key Markets

Aerial lift  
Agriculture  
Bulk chemical handling  
Construction machinery  
Food & beverage  
Fuel & gas delivery  
Industrial machinery  
Life sciences  
Marine  
Mining  
Mobile  
Oil & gas  
Renewable energy  
Transportation

### Key Products

Check valves  
Connectors for low pressure fluid conveyance  
Deep sea umbilicals  
Diagnostic equipment  
Hose couplings  
Industrial hose  
Mooring systems & power cables  
PTFE hose & tubing  
Quick couplings  
Rubber & thermoplastic hose  
Tube fittings & adapters  
Tubing & plastic fittings



## Hydraulics

### Key Markets

Aerial lift  
Agriculture  
Alternative energy  
Construction machinery  
Forestry  
Industrial machinery  
Machine tools  
Marine  
Material handling  
Mining  
Oil & gas  
Power generation  
Refuse vehicles  
Renewable energy  
Truck hydraulics  
Turf equipment

### Key Products

Accumulators  
Cartridge valves  
Electrohydraulic actuators  
Human machine interfaces  
Hybrid drives  
Hydraulic cylinders  
Hydraulic motors & pumps  
Hydraulic systems  
Hydraulic valves & controls  
Hydrostatic steering  
Integrated hydraulic circuits  
Power take-offs  
Power units  
Rotary actuators  
Sensors



## Pneumatics

### Key Markets

Aerospace  
Conveyor & material handling  
Factory automation  
Life science & medical  
Machine tools  
Packaging machinery  
Transportation & automotive

### Key Products

Air preparation  
Brass fittings & valves  
Manifolds  
Pneumatic accessories  
Pneumatic actuators & grippers  
Pneumatic valves & controls  
Quick disconnects  
Rotary actuators  
Rubber & thermoplastic hose & couplings  
Structural extrusions  
Thermoplastic tubing & fittings  
Vacuum generators, cups & sensors



## Process Control

### Key Markets

Alternative fuels  
Biopharmaceuticals  
Chemical & refining  
Food & beverage  
Marine & shipbuilding  
Medical & dental  
Microelectronics  
Nuclear Power  
Offshore oil exploration  
Oil & gas  
Pharmaceuticals  
Power generation  
Pulp & paper  
Steel  
Water/wastewater

### Key Products

Analytical instruments  
Analytical sample conditioning products & systems  
Chemical injection fittings & valves  
Fluoropolymer chemical delivery fittings, valves & pumps  
High purity gas delivery fittings, valves, regulators & digital flow controllers  
Industrial mass flow meters/controllers  
Permanent no-weld tube fittings  
Precision industrial regulators & flow controllers  
Process control double block & bleeds  
Process control fittings, valves, regulators & manifold valves



## Sealing & Shielding

### Key Markets

Aerospace  
Chemical processing  
Consumer  
Fluid power  
General industrial  
Information technology  
Life sciences  
Microelectronics  
Military  
Oil & gas  
Power generation  
Renewable energy  
Telecommunications  
Transportation

### Key Products

Dynamic seals  
Elastomeric o-rings  
Electro-medical instrument design & assembly  
EMI shielding  
Extruded & precision-cut, fabricated elastomeric seals  
High temperature metal seals  
Homogeneous & inserted elastomeric shapes  
Medical device fabrication & assembly  
Metal & plastic retained composite seals  
Shielded optical windows  
Silicone tubing & extrusions  
Thermal management  
Vibration dampening

## Parker Worldwide

### Europe, Middle East, Africa

**AE – United Arab Emirates, Dubai**  
Tel: +971 4 8127100  
parker.me@parker.com

**AT – Austria, Wiener Neustadt**  
Tel: +43 (0)2622 23501-0  
parker.austria@parker.com

**AT – Eastern Europe, Wiener Neustadt**  
Tel: +43 (0)2622 23501 900  
parker.easteurope@parker.com

**AZ – Azerbaijan, Baku**  
Tel: +994 50 2233 458  
parker.azerbaijan@parker.com

**BE/LU – Belgium, Nivelles**  
Tel: +32 (0)67 280 900  
parker.belgium@parker.com

**BG – Bulgaria, Sofia**  
Tel: +359 2 980 1344  
parker.bulgaria@parker.com

**BY – Belarus, Minsk**  
Tel: +48 (0)22 573 24 00  
parker.poland@parker.com

**CH – Switzerland, Etoy**  
Tel: +41 (0)21 821 87 00  
parker.switzerland@parker.com

**CZ – Czech Republic, Klecany**  
Tel: +420 284 083 111  
parker.czechrepublic@parker.com

**DE – Germany, Kaarst**  
Tel: +49 (0)2131 4016 0  
parker.germany@parker.com

**DK – Denmark, Ballerup**  
Tel: +45 43 56 04 00  
parker.denmark@parker.com

**ES – Spain, Madrid**  
Tel: +34 902 330 001  
parker.spain@parker.com

**FI – Finland, Vantaa**  
Tel: +358 (0)20 753 2500  
parker.finland@parker.com

**FR – France, Contamine s/Arve**  
Tel: +33 (0)4 50 25 80 25  
parker.france@parker.com

**GR – Greece, Athens**  
Tel: +30 210 933 6450  
parker.greece@parker.com

**HU – Hungary, Budaörs**  
Tel: +36 23 885 470  
parker.hungary@parker.com

**IE – Ireland, Dublin**  
Tel: +353 (0)1 466 6370  
parker.ireland@parker.com

**IL – Israel**  
Tel: +39 02 45 19 21  
parker.israel@parker.com

**IT – Italy, Corsico (MI)**  
Tel: +39 02 45 19 21  
parker.italy@parker.com

**KZ – Kazakhstan, Almaty**  
Tel: +7 7273 561 000  
parker.easteurope@parker.com

**NL – The Netherlands, Oldenzaal**  
Tel: +31 (0)541 585 000  
parker.nl@parker.com

**NO – Norway, Asker**  
Tel: +47 66 75 34 00  
parker.norway@parker.com

**PL – Poland, Warsaw**  
Tel: +48 (0)22 573 24 00  
parker.poland@parker.com

**PT – Portugal**  
Tel: +351 22 999 7360  
parker.portugal@parker.com

**RO – Romania, Bucharest**  
Tel: +40 21 252 1382  
parker.romania@parker.com

**RU – Russia, Moscow**  
Tel: +7 495 645-2156  
parker.russia@parker.com

**SE – Sweden, Spånga**  
Tel: +46 (0)8 59 79 50 00  
parker.sweden@parker.com

**SK – Slovakia, Banská Bystrica**  
Tel: +421 484 162 252  
parker.slovakia@parker.com

**SL – Slovenia, Novo Mesto**  
Tel: +386 7 337 6650  
parker.slovenia@parker.com

**TR – Turkey, Istanbul**  
Tel: +90 216 4997081  
parker.turkey@parker.com

**UA – Ukraine, Kiev**  
Tel: +48 (0)22 573 24 00  
parker.poland@parker.com

**UK – United Kingdom, Warwick**  
Tel: +44 (0)1926 317 878  
parker.uk@parker.com

**ZA – South Africa, Kempton Park**  
Tel: +27 (0)11 961 0700  
parker.southafrica@parker.com

### North America

**CA – Canada, Milton, Ontario**  
Tel: +1 905 693 3000

**US – USA, Cleveland**  
Tel: +1 216 896 3000

### Asia Pacific

**AU – Australia, Castle Hill**  
Tel: +61 (0)2-9634 7777

**CN – China, Shanghai**  
Tel: +86 21 2899 5000

**HK – Hong Kong**  
Tel: +852 2428 8008

**IN – India, Mumbai**  
Tel: +91 22 6513 7081-85

**JP – Japan, Tokyo**  
Tel: +81 (0)3 6408 3901

**KR – South Korea, Seoul**  
Tel: +82 2 559 0400

**MY – Malaysia, Shah Alam**  
Tel: +60 3 7849 0800

**NZ – New Zealand, Mt Wellington**  
Tel: +64 9 574 1744

**SG – Singapore**  
Tel: +65 6887 6300

**TH – Thailand, Bangkok**  
Tel: +662 186 7000

**TW – Taiwan, Taipei**  
Tel: +886 2 2298 8987

### South America

**AR – Argentina, Buenos Aires**  
Tel: +54 3327 44 4129

**BR – Brazil, Sao Jose dos Campos**  
Tel: +55 800 727 5374

**CL – Chile, Santiago**  
Tel: +56 2 623 1216

**MX – Mexico, Toluca**  
Tel: +52 72 2275 4200

We reserve the right to make technical changes. The data correspond to the technical state at the time of printing.  
© 2017 Parker Hannifin Corporation. All rights reserved.

192-122003N3

06/2017



#### EMEA Product Information Centre

Free phone: 00 800 27 27 5374

(from AT, BE, CH, CZ, DE, DK, EE, ES, FI, FR, IE, IL, IS, IT, LU, MT, NL, NO, PL, PT, RU, SE, SK, UK, ZA)

#### US Product Information Centre

Toll-free number: 1-800-27 27 537

www.parker.com

Your local authorized Parker distributor