

Instrumentation Valves and Manifolds **PREMIER** Range

H Series Product Range



ENGINEERING YOUR SUCCESS.

Contents

Introduction	5
General Technical Information	6
Design and Materials	6
Connections	7
Further Constructional Details, Features and Benefits	8
Available Options	9
Hand Valves - HNV Series	10
Hand Valves - HNAV Series	11
Gauge Valves - HNVV Series	11
Gauge Valves - HGV Series	12
2 Valve Manifolds - HL Series	12
Remote/Line mount - short pattern	12
2 Valve Manifolds - HNL Series	14
Remote/Line mount - long pattern	14
3 & 5 Valve Manifolds - HL Series	15
Remote/Line mount, Pipe to pipe, Thread to thread	15
2, 3 & 5 Valve Manifolds - HD & HE Series	16
Direct mount	16
2, 3 & 5 Valve Manifolds for 2051/3051 Coplanar™ Transmitters	21
Mounting Brackets	23
Brackets for remote/line mount manifolds and gauge valves	23
Brackets for direct mount manifolds	25
Brackets for 2051/3051 Coplanar™ transmitter manifolds	27

PREMIER

Instrumentation Valves and Manifolds for All Industries and Applications

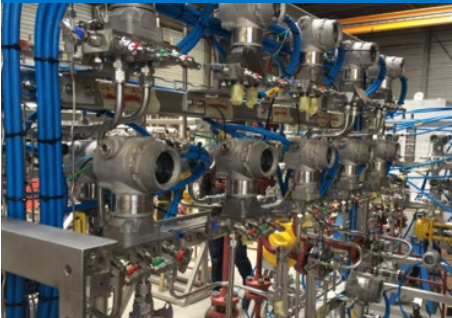

Introduction

Welcome to the Parker **PREMIER** range of process instrumentation valves and manifolds, designed for instrumentation measurement applications. The 'core' **PREMIER** range represents the pinnacle of our product offerings, building upon the well-known and highly regarded H series. We strive to provide exceptional value to our customers, offering the best market lead times and unparalleled quality.

You can make your selections directly from the following pages, and rest assured that we will meet even the highest expectations in terms of service and support.

Choosing **PREMIER** ensures:

- P** Premium design and quality at non-premium pricing
- R** Rapid service response and unbeatable market lead times
- E** Engineered for longevity, ensuring the lowest total cost of ownership
- M** Manufacturing: State-of-the-art UK manufacturing with advanced production planning
- I** Inspired continuous innovation and process improvement
- E** Exceptional 'self-serve' programs, backed by dedicated divisional support if needed
- R** Reliable products, processes, and people.

The top five target markets for Parker Instrumentation are listed below, although Parker **PREMIER** valves and manifolds are suitable for a wide range of process measurement and control applications in various industries.

Please note that continuous product development may require occasional changes in the details provided in this catalogue. Parker reserves the right to make such changes at their discretion and without prior notice. All dimensions shown in this catalogue are approximate and subject to change.

While we strive to provide sufficient, clear, and accurate information to assist you in selecting the right product from this catalogue, it is ultimately the responsibility of the system designer or user to ensure that the chosen product is suitable for the intended application. If you require further information, please don't hesitate to contact your local Parker support.

With thousands of distributor outlets and stores worldwide, as well as hundreds of Parker personnel and locations, we offer the **PREMIER** advantage of local supply and support in your area.



Upstream Oil & Gas



Downstream Oil & Gas



PowerGen



Industrial Gas



Transportation

Parker EHS Vision Statement:

Parker recognizes, and believes, in the importance of safeguarding natural resources and the global environment. We are committed to our employees, our communities, and our customers: their health, safety and understanding of the need for environmental stewardship.

We are committed to the concept of continuous improvement in environmental performance. Accordingly, we are committed to the following principles:

- We will seek to comply with environmental, health, and safety laws worldwide.
- We strive to minimize or eliminate the generation of waste.
- We will monitor compliance with environmental, health and safety regulations.



General Technical Information

Design and Materials

All **PREMIER** valves and manifolds are designed to meet the pressure and temperature ratings of ANSI B16.34 Class 2500/Class 4500 as applicable, limited only by selection of gland packing materials. Conformity to the recommendations of MSS SP-99 is also assured.

Relevant codes, standards and specifications

Code/Specification	Description
DIN EN61518/IEC 61518	Mating interface dimensions for manifolds to transmitters
ASME B16.34	Valves-flanged, threaded and welding end
NACE MR0175 / ISO 15156	Materials for use in H ₂ S containing environments - Oil and Gas processing
API 598	Valves inspection and testing
ISO 5208	Pressure testing of metallic industrial valves
MSS-SP25	Standard marking systems
MSS SP61	Pressure testing of valves
MSS SP 99	Instrument valves

Body/bonnet material options

Material Group	Designator	UNS No.	Werksoff No.	Euronorm Equiv.	ASTM
Austenitic SS	316/316L Dual Certified	UNS S31600/31603	1.4401/1.4404	X5CrNiMo17-12-2	A479 Gr 316
Super Austenitic SS	6Mo	UNS S31254	1.4547	X1CrNiMoCuN20-18-7	A479/A276

Standard specification details

Standard Specification	Optional Specification- See following pages
Seat orifice diameter: 4mm	N/A
Flow co-efficient (Cv): 0.35	N/A
Metal to metal valve seat and stem tip	PEEK soft tip available
All valves and manifolds are subjected to hydrostatic pressure at 1.1x maximum working pressure for the seat, and 1.5x maximum working pressure for the shell	N/A
All products are supplied in clean, burr-free and grease-free condition, making them suitable for most liquid and gaseous applications	N/A
Body and bonnet are fully traceable to the original material source, with a unique trace code applied to the bar stock material	N/A
Certification according to BS EN 10204 3.1 for material and pressure testing is available for download	N/A
All products are permanently marked. Manifolds include a line diagram describing the flow paths	N/A
Complementary to the marking, all bonnet assemblies are functionally colour-coded by the dust caps	N/A
Number of turns open to close: 3.5	N/A
Gauge valves and manifolds do not include plugs as standard	Various plugs available
Direct mount manifolds include flange face seals and high tensile, zinc plated carbon steel mounting bolts	316 SS bolts available
Hand valves do not include mounting holes or threads	Panel Mount available
All manifolds include mounting holes suitable for brackets or enclosure mounting	Brackets available

Connections

Introduction

Parker **PREMIER** valve and manifold products are available in a carefully selected array of connection types and sizes. These products are manufactured to the highest quality standards, utilising state-of-the-art machinery and processes, and are backed by decades of expertise.

The specific connections available are detailed in the following pages, categorised by product type. Some general information is provided below for your reference. Please note, no other options are available other than those stated/shown.

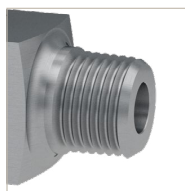

Tapered Pipe Threads - Male and Female

NPT Tapered Thread conforming to ASME B1.20.1 with enhanced manufacturing tolerance for optimal assembly and inspected by three step gauging with Parker enhanced tolerancing to ANPT requirement per ASTM SAE AS71051.



Fully Integrated Tubing Connections

The **PREMIER** Parker Advantage offers the ultimate in safety, reliability, speed, and ease of installation. A select number of valves are available with integral tube connections, utilising Parker A-LOK® (Two Ferrule) compression fitting technology. For full details on the A-LOK® technology, please refer to catalogue reference 4190-FMTG.

Manifold process inlet/instrument outlet Transmitter INTERFACE DIN EN61518/IEC 61518

Parker **PREMIER** manifolds have inlet and outlet interface connections that fully comply with DIN/IEC 61518. For the Manifold to Transmitter interface, the type B connection is utilised. According to DIN/EN 61518, the manifold-transmitter interface is rated for a maximum allowable working pressure of 413 bar (6,000 psi) and a maximum allowable temperature of 120°C (248°F) for liquids gas, or vapours. The maximum allowable temperature of 120°C (248°F) considers the requirement that manifolds and transmitters need to be protected from excessive heating by hot media. This requirement can be achieved by using adequate hook-ups or instrument impulse lines of sufficient length. However, Parker confirms that H series manifolds can be used for temperatures up to 538°C (1,000°F) with graphite gland packing, and up to 260°C (500°F) with PTFE gland packing.

Process inlet to manifold / transmitter interface DIN EN 61518 / IEC 61518

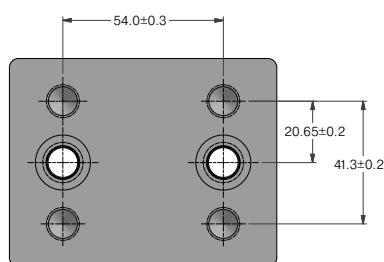
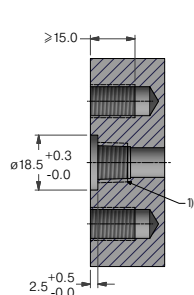

Process outlet to transmitter interface DIN EN 61518 / IEC 61518 Type B

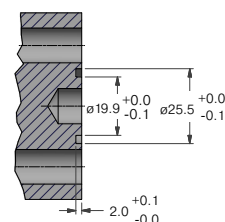
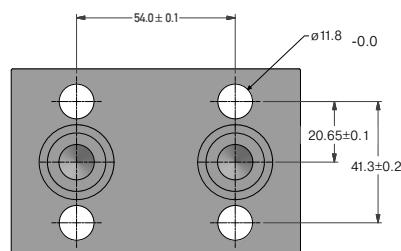

	IEC 61518 Type B	
Maximum allowable working pressure	413 bar (6,000 PSI)	
Temperature range	PTFE: -10°C to +80°C (14°F to 176°F)	Graphite: -40°C to +120°C (-40°F to 248°F)
Seal ring	Flat Ring 25.4 x 20 x 2.7 Material: PTFE	Flat Ring 25.4 x 19.9 x 2.9 Material: Graphite
N=Minimum thread engagement	9mm	9mm
Replacement seal part number	HIEC001-PTFE/1	HIEC001-GRAPHITE/1

Important Note: the only exception to the IEC 61518 standard is for the Emerson Coplanar™ transmitter design. Parker offers a full range of specifically suitable manifolds for this type. See pages 21-22.

Further Constructional Details, Features and Benefits

ANSI Class 2500 (6,000 PSI) and Class 4500 (10,000 PSI) offering safe, reliable and repeatable performance

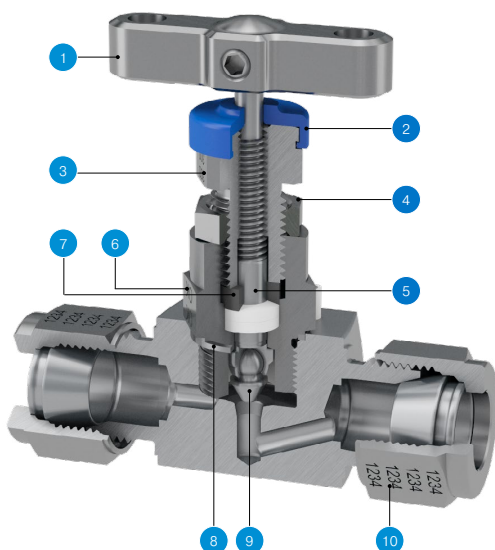

Item	Description
1	Ergonomic 'T' bar style handle with positive retention
2	Dual purpose dust cap provides functional identification
3	Compensatory adjustable gland
4	Secure anti-vibration gland lock nut
5	Anti-blowout low torque back seating stem
6	All metal body bonnet seal
7	Gland thrust bush ensures uniform packing compression and tight sealing
8	Annealed sealing washer guarantees 100% sealing assurance
9	Self-centering, non-rotating stem tip guarantees bubble tight shut-off
10	Material traceability for major pressure containing components

Pressure vs temperature

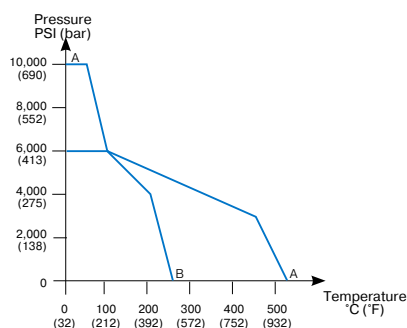

Reference	Description
A - A	Graphite packing
A - B	PTFE packing

Notes:

- Pressure and temperature ratings shown are maximum possible values. Continuous operation at the maximum ratings will reduce life expectancy.
- Pressure and temperature ratings can be derated by certain connection types or materials of construction.

Available Options

Panel Mount (PM) – Hand valves only. Available factory fit or separately for Retro Fit.



Factory Fitted Option Suffix	PM
Retrofit Kit Part Number	KITPM

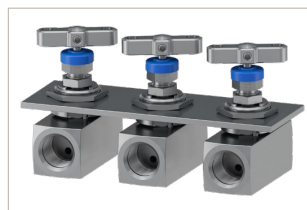

Hole Diameter	26mm (1.02")
Panel Thickness	Max. 5mm (0.20") Min. 2.3mm (0.09")
Min. distance for panel mount spacing	51mm (2.00")

PEEK Soft Tip Bonnet Design (PK)



- Ideal for clean gaseous or other services where bubble-tight shut-off with minimum effort is required
- Suitable for temperatures up to 204°C and pressures up to 10,000 PSI at reduced temperature, as per graph.

Pressure vs temperature

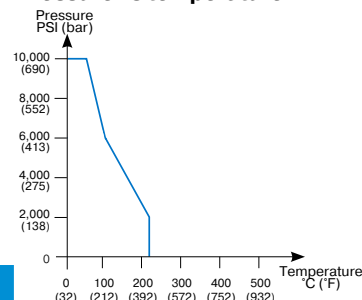

Anti-Tamper Operation - to vents/drains and/or equalise only. Available separately or with Manifold, with or without Key - as per table ONLY.



	Supplied with Valve - Option Suffix	Supplied separately - Option Suffix
With Key	To vent - ATKV To equalise - ATKE To equalise & vent - ATKEV	KITAK
Without Key	To vent - ATV To equalise - ATVE To equalise & vent - ATE	KITAT

Blank Plugs (P), Bleed Plugs (BV) or both as applicable (PBV). Also available separately.



Supplied with Valve - Option Suffix	Plug		Bleed Plug		
P (Plug)	Size/Material	316 SS	6MO	316 SS	6MO
BV (Bleed plug)	¼" NPT	HPHS4M	HPH6MO4M	HBVS4M	HBV6MO4M
PBV (Plug & Bleed plug)	½" NPT	HPHS8M	HPH6MO8M	HBVS8M	HBV6MO8M

Part Nomenclature and Creation – Important

Throughout this catalogue, we have outlined all the **PREMIER** products and options that are available. To aid the user, we have included top-level part numbers for all available products, sorted by type. We have also provided a list of available options, along with examples of how these options impact the part numbers. There are no other options available with this **PREMIER** range.

It is **IMPERATIVE** to adhere to the correct nomenclature and sequencing for this nomenclature. The following breakdown will assist users in validating their selections against the included examples.

Please note: not all options are compatible with every basic product type. Some options cannot be combined. For instance, the PEEK soft tip and Graphite packing cannot be used together in any product type. Care should be taken to follow the guidelines provided in the catalogue.

		OPTIONS								
		As applicable. Please refer to detailed information on individual product pages.								
PREMIER Part Number (Default)		High Pressure	SS Transmitter Mounting Bolts	Graphite (High Temperature) Packing	PEEK Soft Tip	Plugs (Blank or/and Bleed)	Anti-Tamper Operation	Panel Mount	Mounting Brackets	NACE
EXAMPLES	HNV*8FF	HP	N/A	N/A	PK	N/A	N/A	PM	N/A	NC
	HNVV*8M8F	HP	N/A	3	N/A	BV	N/A	N/A	N/A	NC
	HGV*8M8F	HP	N/A	N/A	PK	PBV	N/A	N/A	N/A	NC
	HNL*2V8M8F4F	HP	N/A	3	N/A	P	ATV	N/A	BK	NC
	HD*3MA	N/A	SB	3	N/A	N/A	ATE	N/A	BKS	NC
	HD*5MA	N/A	SB	N/A	PK	P	ATKEV	N/A	BK	NC

* Material designator: S - 316 stainless steel; 6MO - super austenitic stainless steel. Only two available material options.

Hand Valves - HNV Series

With a small bore and a needle/plug stem tip, Parker **PREMIER** hand valves allow precise regulation of flow in low-flow applications for a wide variety of media. These hand valves are widely used in situations where the flow must be gradually brought to a halt and in other instances where precise adjustments of flow are necessary.

Fully integrated tubing connections - 6,000 PSI max

Incorporating Parker globally renowned A-LOK® tube fittings technology. Please also refer to Parker Fittings, Materials and Tubing Selection Guide ref. 4190-FMTG.

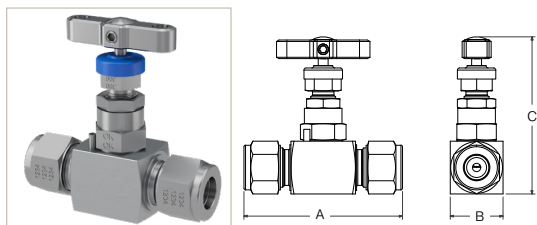

Note: Thinner wall tube selections will down rate the assembly. Refer to catalogue 4190-FMTG.

AVAILABLE PREMIER SELECTION

Material		Inlet	Outlet	Option	Dimension		
Stainless Steel	6MO	A-LOK®	A-LOK®		A mm (inch)	B mm (inch)	C mm (inch)
HNVS4A	HNVMO4A	1/4"	1/4"	PTFE gland	67.5 (2.66")	25.4 (1.00")	76.2 (3.00")
HNVS8A	HNVMO8A	1/2"	1/2"	PTFE gland	76.2 (3.00")	25.4 (1.00")	76.2 (3.00")
HNVS6A	HNVMOM6A	6mm	6mm	PTFE gland	67.5 (2.66")	25.4 (1.00")	76.2 (3.00")
HNVS12A	HNVMOM12A	12mm	12mm	PTFE gland	76.2 (3.00")	25.4 (1.00")	76.2 (3.00")
HNVS4A3	HNVMO4A3	1/4"	1/4"	Graphite gland	67.5 (2.66")	25.4 (1.00")	76.2 (3.00")
HNVS8A3	HNVMO8A3	1/2"	1/2"	Graphite gland	76.2 (3.00")	25.4 (1.00")	76.2 (3.00")
HNVS6A3	HNVMOM6A3	6mm	6mm	Graphite gland	67.5 (2.66")	25.4 (1.00")	76.2 (3.00")
HNVS12A3	HNVMOM12A3	12mm	12mm	Graphite gland	76.2 (3.00")	25.4 (1.00")	76.2 (3.00")
HNVS4APK	HNVMO4APK	1/4"	1/4"	PEEK tip	67.5 (2.66")	25.4 (1.00")	76.2 (3.00")
HNVS8APK	HNVMO8APK	1/2"	1/2"	PEEK tip	76.2 (3.00")	25.4 (1.00")	76.2 (3.00")
HNVS6APK	HNVMOM6APK	6mm	6mm	PEEK tip	67.5 (2.66")	25.4 (1.00")	76.2 (3.00")
HNVS12APK	HNVMOM12APK	12mm	12mm	PEEK tip	76.2 (3.00")	25.4 (1.00")	76.2 (3.00")

Female x Female NPT threaded connections - 6,000 PSI or 10,000 PSI (414 Bar or 690 Bar)

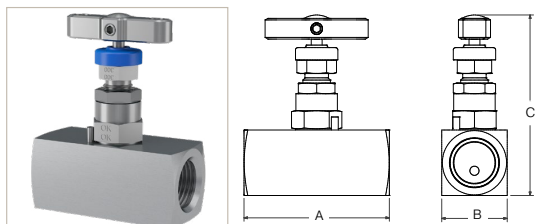

AVAILABLE PREMIER SELECTION

Material		Pressure PSig	Inlet	Outlet	Option	Dimension		
Stainless Steel	6MO		Female	Female		A mm (inch)	B mm (inch)	C mm (inch)
HNVS4FF	HNVMO4FF	6,000	1/4" NPT	1/4" NPT	PTFE gland	54.0 (2.13")	28.6 (1.13")	79.4 (3.13")
HNVS8FF	HNVMO8FF		1/2" NPT	1/2" NPT	PTFE gland	63.5 (2.50")	28.6 (1.13")	79.4 (3.13")
HNVS4FFHP	HNVMO4FFHP	10,000	1/4" NPT	1/4" NPT	PTFE gland	60.5 (2.38")	31.8 (1.25")	82.6 (3.25")
HNVS8FFHP	HNVMO8FFHP		1/2" NPT	1/2" NPT	PTFE gland	69.9 (2.75")	31.8 (1.25")	82.6 (3.25")
HNVS4FF3	HNVMO4FF3	6,000	1/4" NPT	1/4" NPT	Graphite gland	54.0 (2.13")	28.6 (1.13")	79.4 (3.13")
HNVS8FF3	HNVMO8FF3		1/2" NPT	1/2" NPT	Graphite gland	63.5 (2.50")	28.6 (1.13")	79.4 (3.13")
HNVS4FFHP3	HNVMO4FFHP3	10,000	1/4" NPT	1/4" NPT	Graphite gland	60.5 (2.38")	31.8 (1.25")	82.6 (3.25")
HNVS8FFHP3	HNVMO8FFHP3		1/2" NPT	1/2" NPT	Graphite gland	69.9 (2.75")	31.8 (1.25")	82.6 (3.25")
HNVS4FFPK	HNVMO4FFPK	6,000	1/4" NPT	1/4" NPT	PEEK tip	54.0 (2.13")	28.6 (1.13")	79.4 (3.13")
HNVS8FFPK	HNVMO8FFPK		1/2" NPT	1/2" NPT	PEEK tip	63.5 (2.50")	28.6 (1.13")	79.4 (3.13")
HNVS4FFHPK	HNVMO4FFHPK	10,000	1/4" NPT	1/4" NPT	PEEK tip	60.5 (2.38")	31.8 (1.25")	82.6 (3.25")
HNVS8FFHPK	HNVMO8FFHPK		1/2" NPT	1/2" NPT	PEEK tip	69.9 (2.75")	31.8 (1.25")	82.6 (3.25")

Male x Female NPT threaded connections - 6,000 PSI or 10,000 PSI (414 Bar or 690 Bar)

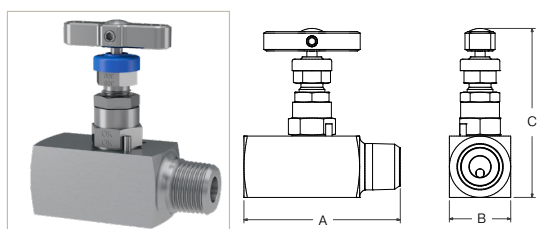

AVAILABLE PREMIER SELECTION

Material		Pressure PSig	Inlet	Outlet	Option	Dimension		
Stainless Steel	6MO		Male	Female		A mm (inch)	B mm (inch)	C mm (inch)
HNVS8M8F	HNVMO8M8F	6,000	1/2" NPT	1/2" NPT	PTFE gland	73.0 (2.87")	28.6 (1.13")	79.4 (3.13")
HNVS8M8FHP	HNVS8M8FHP	10,000	1/2" NPT	1/2" NPT	PTFE gland	76.2 (3.00")	31.8 (1.25")	82.6 (3.25")
HNVS8M8F3	HNVMO8M8F3	6,000	1/2" NPT	1/2" NPT	Graphite gland	73.0 (2.87")	28.6 (1.13")	79.4 (3.13")
HNVS8M8FHP3	HNVS8M8FHP3	10,000	1/2" NPT	1/2" NPT	Graphite gland	76.2 (3.00")	31.8 (1.25")	82.6 (3.25")
HNVS8M8FPK	HNVMO8M8FPK	6,000	1/2" NPT	1/2" NPT	PEEK tip	73.0 (2.87")	28.6 (1.13")	79.4 (3.13")
HNVS8M8FHPK	HNVS8M8FHPK	10,000	1/2" NPT	1/2" NPT	PEEK tip	76.2 (3.00")	31.8 (1.25")	82.6 (3.25")

NOTE: Graphite (3) packing and PEEK (PK) tip not available together.

Examples – How to specify the available options

Panel Mount (PM) - For full details, see page 9.

Add suffix **PM** within the part number, for example:

HNVS4APM
HNVMOM12APM
HNVS8FFHP3PM

NACE MR0175 ISO15156 (NC) – For full details, see page 6.

Add suffix **NC** within the part number, for example:

HNVS4APMNC
HNVMOM12APMNC
HNVS8M8F3PMNC

Example – 10K PSI with PEEK tip, Panel Mount and NACE: **HNVS8FFHPKPMNC**

Hand Valves - HNAV Series

These Parker **PREMIER** angle pattern hand valves have all the advantages of straight pattern hand valves, with the added benefit of reducing componentry, installation time, cost, and potential emissions. They can also be used to create a change of direction in the tubing hookup without the need for additional tubes and elbow fittings.

Female x Female 1/2" NPT threaded connections - 6,000 PSI or 10,000 PSI (414 Bar or 690 Bar)

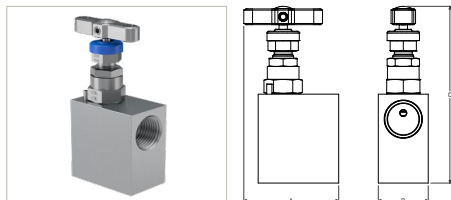

AVAILABLE **PREMIER** SELECTION

Material		Pressure PSIg	Option		Dimension		
Stainless Steel	6MO		Gland	Tip	A	B	C
HNAV8FF	HNAV6MO8FF	6,000	PTFE	Std Hard	54.3 (2.14)	28.6 (1.13)	101.0 (3.98)
HNAV8FF3	HNAV6MO8FF3	6,000	Graphite	Std Hard	54.3 (2.14)	28.6 (1.13)	101.0 (3.98)
HNAV8FFPK	HNAV6MO8FFPK	6,000	PTFE	PEEK Tip	54.3 (2.14)	28.6 (1.13)	101.0 (3.98)
HNAV8FFHPPK	HNAV6MO8FFHPPK	10,000	PTFE	PEEK Tip	76.2 (3.00")	25.4 (1.00")	76.2 (3.00")

Male x Female 1/2" NPT threaded connections - 6,000 PSI (414 Bar)

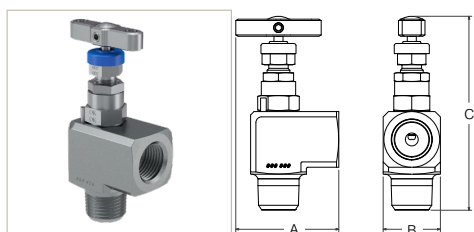

AVAILABLE **PREMIER** SELECTION

Material		Pressure PSIg	Option		Dimension		
Stainless Steel	6MO		Gland	Tip	A	B	C
HNAV8M8F	HNAV6MO8M8F	6,000	PTFE	Std Hard	54.3 (2.14)	30.1 (1.19)	102.2 (4.02)
HNAV8M8F3	HNAV6MO8M8F3	6,000	Graphite	Std Hard	54.3 (2.14)	30.1 (1.19)	102.2 (4.02)
HNAV8M8FPK	HNAV6MO8M8FPK	6,000	PTFE	PEEK Tip	54.3 (2.14)	30.1 (1.19)	102.2 (4.02)

NOTE: Graphite **(3)** packing and PEEK **(PK)** tip not available together.

Examples – How to specify the available options

Panel Mount (PM) - For full details, see page 9.

Add the suffix **PM** within the part number, for example:

HNAV8M8FPM
HNAV8M8FHPKPM
HNAV6MO8M8FPM

NACE MR0175 ISO15156 (NC) – For full details, see page 6.

Add the suffix **NC** within the part number, for example:

HNAV8M8FPMNC
HNAV6MO8M8FHPKPMNC

Example – PEEK tip, Panel Mount and NACE: **HNAV6MO8M8FHPKPMNC**

Gauge Valves - HNVV Series

Generally used in conjunction with the measuring instrument, these **PREMIER** single block gauge vent valves allow for the venting and draining of any process media that may be trapped following the isolation of the instrument for maintenance and/or removal purposes.

Male x Female 1/2" NPT threaded connections with 1/4" NPT vent - 6,000 PSI or 10,000 PSI (414 Bar or 690 Bar)

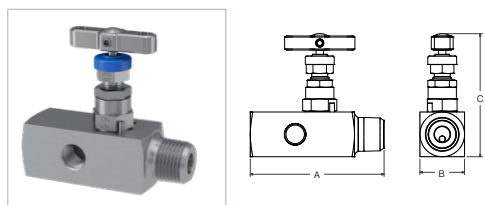

AVAILABLE **PREMIER** SELECTION

Material		Pressure PSIg	Option		Dimension		
Stainless Steel	6MO		Gland	Tip	A	B	C
HNVV8M8F	HNVV6MO8M8F	6,000	PTFE	Std Hard	85.8 (3.38)	28.6 (1.13)	79.4 (3.13)
HNVV8M8FHP	HNVV6MO8M8FHP	10,000	PTFE	Std Hard	85.6 (3.37)	31.8 (1.25)	82.6 (3.25)
HNVV8M8F3	HNVV6MO8M8F3	6,000	Graphite	Std Hard	85.8 (3.38)	28.6 (1.13)	79.4 (3.13)
HNVV8M8FHP3	HNVV6MO8M8FHP3	10,000	Graphite	Std Hard	85.6 (3.37)	31.8 (1.25)	82.6 (3.25)
HNVV8M8FHPK	HNVV6MO8M8FHPK	6,000	PTFE	PEEK Tip	85.8 (3.38)	28.6 (1.13)	79.4 (3.13)
HNVV8M8FHPK	HNVV6MO8M8FHPK	10,000	PTFE	PEEK Tip	85.6 (3.37)	31.8 (1.25)	82.6 (3.25)

Examples – How to specify the available options

1/4" NPT Blank Plug **(P)** or Bleed Plug **(BV)** - For full details, see page 9.

Add the suffix **P** or **BV** within the part number, for example:

HNVV8M8FP
HNVV6MO8M8FHPBV
HNVV8M8FHP3P

NACE MR0175 ISO15156 **(NC)** – For full details, see page 6.

Add the suffix **NC** within the part number, for example:

HNVV8M8FPNC
HNVV6MO8M8FHPBVNC
HNVV8M8FHP3NC

Example – 10K PSI, PEEK tip, Bleed plug and NACE: **HNVV6MO8M8FHPKBPVNC**

Gauge Valves - HGV Series

Also generally used in conjunction with measuring instruments, these multi-port **PREMIER** single block gauge valves allow for flexibility in use when two instruments may be required. They also offer the function of venting and draining any process media that may be trapped following the isolation of an instrument for maintenance, calibration, or removal purposes.

Male x Female 1/2" NPT threaded connections with 3 outlets - 6,000 PSI or 10,000 PSI (414 Bar or 690 Bar)

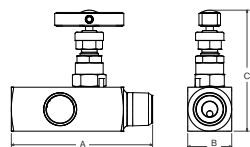

AVAILABLE PREMIER SELECTION

Material		Pressure PSig	Option		Dimension		
Stainless Steel	6MO		Gland	Tip	A	B	C
HGVS8M8F	HGV6MO8M8F	6,000	PTFE	Std Hard	92.0 (3.82)	28.6 (1.13)	79.4 (3.13)
HGVS8M8FHP	HGV6MO8M8FHP	10,000	PTFE	Std Hard	92.0 (3.82)	31.8 (1.25)	81.9 (3.22)
HGVS8M8F3	HGV6MO8M8F3	6,000	Graphite	Std Hard	92.0 (3.82)	28.6 (1.13)	79.4 (3.13)
HGVS8M8FHP3	HGV6MO8M8FHP3	10,000	Graphite	Std Hard	92.0 (3.82)	31.8 (1.25)	81.9 (3.22)
HGVS8M8F3PK	HGV6MO8M8F3PK	6,000	PTFE	PEEK Tip	92.0 (3.82)	28.6 (1.13)	79.4 (3.13)
HGVS8M8FHP3PK	HGV6MO8M8FHP3PK	10,000	PTFE	PEEK Tip	92.0 (3.82)	31.8 (1.25)	81.9 (3.22)

NOTE: Graphite (3) packing and PEEK (PK) tip not available together.

Examples – How to specify the available options

1/2" NPT Blank Plug (P) or Bleed Plug (BV) or both - For full details, see page 9.

Add the suffix **P** or **BV** within the part number, for example:

HGVS8M8FP
HGV6MO8M8FHPBV
HGVS8M8FHP3P

NACE MR0175 ISO15156 (NC) – For full details, see page 6.

Add the suffix **NC** within the part number, for example:

HGVS8M8FPNC
HGV6MO8M8FHPBVNC
HGVS8M8FHP3BVNC

Example – 10K PSI, PEEK tip, Plug, Bleed plug and NACE: **HGVS6MO8M8FHPPKPBVNC**

2 Valve Manifolds - HL Series

Remote/line mount - short pattern

Combining two needle valves into one unitised block, these **PREMIER** Parker 2-valve manifolds are also referred to as Block and Bleed, Isolate and Calibrate, or even Isolate and Vent/Drain. These manifolds are primarily used in applications requiring a pressure switch, pressure transmitter, or gauge for Static Pressure Measurement. Other forms of sensing technology can be applied, and in some circumstances, they can also be employed in the measurement of temperature or other process attribute. These short-pattern variants are particularly ideal for robust mounting to brackets or other structures, whilst the angle pattern version ensures ease of use in confined spaces.

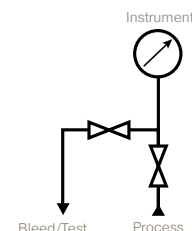

Male/Female x Female 1/2" NPT threaded connections with 1/4" NPT vent - 6,000 PSI or 10,000 PSI (414 Bar or 690 Bar)

AVAILABLE PREMIER SELECTION

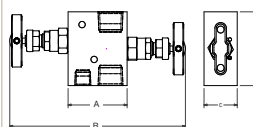

Material		Pressure PSig	Option		Dimension			
Stainless Steel	6MO		Gland	Tip	A	B	C	D
HLS2V	HL6MO2V	6,000	PTFE	Std Hard	50.8 (2.00)	152.4 (6.00)	28.6 (1.13)	63.5 (2.5)
HLS2VHP	HL6MO2VHP	10,000	PTFE	Std Hard	50.8 (2.00)	152.4 (6.00)	31.8 (1.25)	69.8 (2.75)
HLS2V3	HL6MO2V3	6,000	Graphite	Std Hard	50.8 (2.00)	152.4 (6.00)	28.6 (1.13)	63.5 (2.5)
HLS2VHP3	HL6MO2VHP3	10,000	Graphite	Std Hard	50.8 (2.00)	152.4 (6.00)	31.8 (1.25)	69.8 (2.75)
HLS2V3PK	HL6MO2V3PK	6,000	PTFE	PEEK Tip	50.8 (2.00)	152.4 (6.00)	28.6 (1.13)	63.5 (2.5)
HLS2VHP3PK	HL6MO2VHP3PK	10,000	PTFE	PEEK Tip	50.8 (2.00)	152.4 (6.00)	31.8 (1.25)	69.8 (2.75)

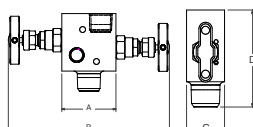

Material		Pressure PSig	Option		Dimension			
Stainless Steel	6MO		Gland	Tip	A	B	C	D
HLS2V8M8F4F	HL6MO2V8M8F4F	6,000	PTFE	Std Hard	50.8 (2.00)	152.4 (6.00)	28.6 (1.13)	73 (2.88)
HLS2V8M8F4FHP	HL6MO2V8M8F4FHP	10,000	PTFE	Std Hard	50.8 (2.00)	152.4 (6.00)	31.8 (1.25)	76.2 (3.00)
HLS2V8M8F4F3	HL6MO2V8M8F4F3	6,000	Graphite	Std Hard	50.8 (2.00)	152.4 (6.00)	28.6 (1.13)	73 (2.88)
HLS2V8M8F4FHP3	HL6MO2V8M8F4FHP3	10,000	Graphite	Std Hard	50.8 (2.00)	152.4 (6.00)	31.8 (1.25)	76.2 (3.00)
HLS2V8M8F4F3PK	HL6MO2V8M8F4F3PK	6,000	PTFE	PEEK Tip	50.8 (2.00)	152.4 (6.00)	28.6 (1.13)	73 (2.88)
HLS2V8M8F4FHP3PK	HL6MO2V8M8F4FHP3PK	10,000	PTFE	PEEK Tip	50.8 (2.00)	152.4 (6.00)	31.8 (1.25)	76.2 (3.00)

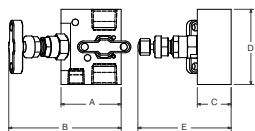

Material		Pressure PSIg	Option		Dimension				
Stainless Steel	6MO		Gland	Tip	A	B	C	D	E
HALS2V	HAL6MO2V	6,000	PTFE	Std Hard	50.8 (2.00)	100.5 (3.96)	28.6 (1.13)	63.5 (2.50)	79.4 (3.13)
HALS2VHP	HAL6MO2VHP	10,000	PTFE	Std Hard	63.5 (2.50)	114.3 (4.5)	31.8 (1.25)	69.8 (2.75)	82.6 (3.25)
HALS2V3	HAL6MO2V3	6,000	Graphite	Std Hard	50.8 (2.00)	100.5 (3.96)	28.6 (1.13)	63.5 (2.50)	79.4 (3.13)
HALS2VHP3	HAL6MO2VHP3	10,000	Graphite	Std Hard	63.5 (2.50)	114.3 (4.5)	31.8 (1.25)	69.8 (2.75)	82.6 (3.25)
HALS2VPK	HAL6MO2VPK	6,000	PTFE	PEEK Tip	50.8 (2.00)	100.5 (3.96)	28.6 (1.13)	63.5 (2.50)	79.4 (3.13)
HALS2VHPPK	HAL6MO2VHPPK	10,000	PTFE	PEEK Tip	63.5 (2.50)	114.3 (4.5)	31.8 (1.25)	69.8 (2.75)	82.6 (3.25)

OPTION — Double Block & Bleed Female x Female 1/2" NPT threaded connections with 1/4" NPT vent - 6,000 PSI or 10,000 (414 Bar or 690 Bar) for double isolation in the most critical applications. Ideal for on panel or robust bracket mounting.

AVAILABLE **PREMIER** SELECTION

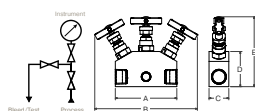

Material		Pressure PSIg	Option		Dimension				
Stainless Steel	6MO		Gland	Tip	A	B	C	D	E
HLS3DBB	HL6MOSDBB	6,000	PTFE	Std Hard	88.9 (3.50)	148.3 (5.84)	28.6 (1.13)	50.8 (2.00)	101.6 (4.00)
HLS3DBBHP	HL6MO3DBBHP	10,000	PTFE	Std Hard	88.9 (3.50)	148.3 (5.84)	31.8 (1.25)	57.2 (2.75)	107.7 (4.25)
HLS3DBB3	HL6MO3DBB3	6,000	Graphite	Std Hard	88.9 (3.50)	148.3 (5.84)	28.6 (1.13)	50.8 (2.00)	101.6 (4.00)
HLS3DBBHP3	HL6MO3DBBHP3	10,000	Graphite	Std Hard	88.9 (3.50)	148.3 (5.84)	31.8 (1.25)	57.2 (2.75)	107.7 (4.25)
HLS3DBBPK	HL6MO3DBBPK	6,000	PTFE	PEEK Tip	88.9 (3.50)	148.3 (5.84)	28.6 (1.13)	50.8 (2.00)	101.6 (4.00)
HLS3DBBHPK	HL6MO3DBBHPK	10,000	PTFE	PEEK Tip	88.9 (3.50)	148.3 (5.84)	31.8 (1.25)	57.2 (2.75)	107.7 (4.25)

Examples – How to specify the available options

1/4" NPT Blank Plug (**P**) or Bleed Plug (**BV**) - For full details, see page 9.

Add the suffix **P** or **BV** within the part number, for example:

HLS3DBBP
HL6MO3DBBHPBV
HLS3DBBHP3P

Anti-Tamper operation (**AT**) – Vent valve only – Available separately or with manifold, with or without key. For full details, see page 9.

Add the suffix **ATV** or **ATKV** within the part number, for example:

HLS3DBBPATV
HL6MO3DBBHPBVATKV
HLS3DBBHP3ATV

Mounting Bracket – Available separately or with manifold in Carbon Steel (**BK**) or stainless Steel (**BKS**). For full details, see page 23.

Add the suffix **BK** or **BKS** within the part number, for example:

HLS3DBBBK
HL6MO3DBBHPBKS
HLS3DBBHP3ATVBK

NACE MR0175 ISO15156 (**NC**) – For full details, see page 6.

Add the suffix **NC** within the part number, for example:

HLS3DBBNC
HL6MO3DBBHPBKSNK
HLS3DBBHP3ATKVBKNC

Example – 10K PSI, PEEK tip, Anti Tamper vent with Key, Bleed plug, Carbon Steel Bracket and NACE: **HL6MO3DBBHPKVBKNC**

2 Valve Manifolds - HNL Series

Remote/line mount - long pattern

These long pattern **PREMIER** 2-valve Block and Bleed, Isolate and Calibrate, Isolate/Vent/Drain manifolds have a similar application purpose and functionality as the short pattern variants of the HL series. However, their slimline nature makes them particularly appealing for free-standing applications where restrictions and orientation are less problematic. These manifolds have become a firm favorite among OEM customers due to their easy installation package/solution, combined with their instruments, which makes them suitable for almost all application situations.

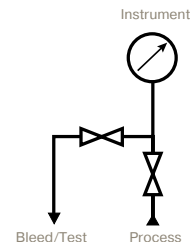

Female x Female 1/2" NPT threaded connections with 1/4" NPT vent - 6,000 PSI or 10,000 PSI (414 Bar or 690 Bar)

AVAILABLE PREMIER SELECTION

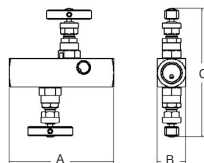
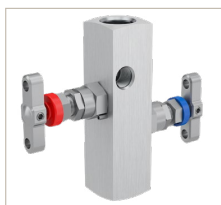

Material		Pressure PSig	Option		Dimension		
Stainless Steel	6MO		Gland	Tip	A	B	C
HNLS2V	HNL6MO2V	6,000	PTFE	Std Hard	105.1 (4.14)	28.6 (1.13)	130.2 (5.13)
HNLS2VHP	HNL6MO2VHP	10,000	PTFE	Std Hard	105.1 (4.14)	31.8 (1.25)	133.4 (5.25)
HNLS2V3	HNL6MO2V3	6,000	Graphite	Std Hard	105.1 (4.14)	28.6 (1.13)	130.2 (5.13)
HNLS2VHP3	HNL6MO2VHP3	10,000	Graphite	Std Hard	105.1 (4.14)	31.8 (1.25)	133.4 (5.25)
HNLS2VPK	HNL6MO2VPK	6,000	PTFE	PEEK Tip	105.1 (4.14)	28.6 (1.13)	130.2 (5.13)
HNLS2VHPPK	HNL6MO2VHPPK	10,000	PTFE	PEEK Tip	105.1 (4.14)	31.8 (1.25)	133.4 (5.25)

Male x Female 1/2" NPT threaded connections with 1/4" NPT vent - 6,000 PSI or 10,000 PSI (414 Bar or 690 Bar)

AVAILABLE PREMIER SELECTION

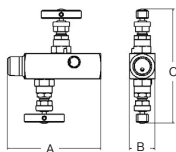

Material		Pressure PSig	Option		Dimension		
Stainless Steel	6MO		Gland	Tip	A	B	C
HNLS2V8M8F4F	HNL6MO2V8M8F4F	6,000	PTFE	Std Hard	105.1 (4.14)	28.6 (1.13)	130.2 (5.13)
HNLS2V8M8F4FHP	HNL6MO2V8M8F4FHP	10,000	PTFE	Std Hard	136.7 (5.38)	31.8 (1.25)	133.4 (5.25)
HNLS2V8M8F4F3	HNL6MO2V8M8F4F3	6,000	Graphite	Std Hard	105.1 (4.14)	28.6 (1.13)	130.2 (5.13)
HNLS2V8M8F4FHP3	HNL6MO2V8M8F4FHP3	10,000	Graphite	Std Hard	136.7 (5.38)	31.8 (1.25)	133.4 (5.25)
HNLS2VM8F4FPK	HNL6MO2V8M8F4FPK	6,000	PTFE	PEEK Tip	105.1 (4.14)	28.6 (1.13)	130.2 (5.13)
HNLS2V8M8F4FHPPK	HNL6MO2V8M8F4FHPPK	10,000	PTFE	PEEK Tip	136.7 (5.38)	31.8 (1.25)	133.4 (5.25)

Female x Male 1/2" NPT threaded connections with 1/4" NPT vent - 6,000 PSI or 10,000 PSI (414 Bar or 690 Bar)

AVAILABLE PREMIER SELECTION

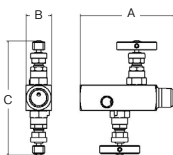

Material		Pressure PSig	Option		Dimension		
Stainless Steel	6MO		Gland	Tip	A	B	C
HNLS2V8F8M4F	HNL6MO2V8F8M4F	6,000	PTFE	Std Hard	105.1 (4.14)	28.6 (1.13)	130.2 (5.13)
HNLS2V8F8M4FHP	HNL6MO2V8F8M4FHP	10,000	PTFE	Std Hard	136.7 (5.38)	31.8 (1.25)	133.4 (5.25)
HNLS2V8F8M4F3	HNL6MO2V8F8M4F3	6,000	Graphite	Std Hard	105.1 (4.14)	28.6 (1.13)	130.2 (5.13)
HNLS2V8F8M4FHP3	HNL6MO2V8F8M4FHP3	10,000	Graphite	Std Hard	136.7 (5.38)	31.8 (1.25)	133.4 (5.25)
HNLS2V8F8M4FPK	HNL6MO2V8F8M4FPK	6,000	PTFE	PEEK Tip	105.1 (4.14)	28.6 (1.13)	130.2 (5.13)
HNLS2V8F8M4FHPPK	HNL6MO2V8F8M4FHPPK	10,000	PTFE	PEEK Tip	136.7 (5.38)	31.8 (1.25)	133.4 (5.25)

Male x Male 1/2" NPT threaded connections with 1/4" NPT vent - 6,000 PSI or 10,000 PSI (414 Bar or 690 Bar)

AVAILABLE PREMIER SELECTION

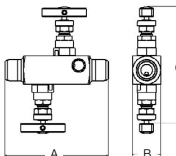
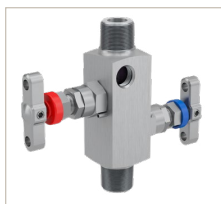

Material		Pressure PSig	Option		Dimension		
Stainless Steel	6MO		Gland	Tip	A	B	C
HNLS2V8M8M4F	HNL6MO2V8M8M4F	6,000	PTFE	Std Hard	105.1 (4.14)	28.6 (1.13)	130.2 (5.13)
HNLS2V8M8M4FHP	HNL6MO2V8M8M4FHP	10,000	PTFE	Std Hard	136.7 (5.38)	31.9 (1.25)	133.4 (5.25)
HNLS2V8M8M4F3	HNL6MO2V8M8M4F3	6,000	Graphite	Std Hard	105.1 (4.14)	28.6 (1.13)	130.2 (5.13)
HNLS2V8M8M4FHP3	HNL6MO2V8M8M4FHP3	10,000	Graphite	Std Hard	136.7 (5.38)	31.9 (1.25)	133.4 (5.25)
HNLS2V8M8M4FPK	HNL6MO2V8M8M4FPK	6,000	PTFE	PEEK Tip	105.1 (4.14)	28.6 (1.13)	130.2 (5.13)
HNLS2V8M8M4FHPPK	HNL6MO2V8M8M4FHPPK	10,000	PTFE	PEEK Tip	136.7 (5.38)	31.9 (1.25)	133.4 (5.25)

NOTE: Graphite (3) packing and PEEK (PK) tip not available together.

Examples – How to specify the available options

1/4" NPT Blank Plug (P) or Bleed Plug (BV) - For full details, see page 9.

Add the suffix P or BV within the part number, for example:

HNLS2VP
HNL6MO2V8M8F4FHPBV
HNLS2VHP3P

Anti Tamper operation (AT) – Vent valve only – Available separately or with manifold, with or without key. For full details, see page 9.

Add the suffix ATV or ATKV within the part number, for example:

HNLS2VPATV
HNL6MO2V8M8F4FHPBVATKV
HNLS2VHP3ATV

NACE MR0175 ISO15156 (NC) – For full details, see page 6.

Add the suffix NC within the part number, for example:

HNLS2VNC
HNL6MO2V8M8F4FHPNC
HNLS2VHP3ATKVCNC

Example – 10K PSI, PEEK tip, Anti Tamper vent with Key, Bleed plug and NACE: **HNL6MO2V8M8F4FHPPKBVATKVCNC**

3 & 5 Valve Manifolds - HL Series

Remote/line mount, pipe to pipe, thread to thread

The Parker **PREMIER** range of 3 and 5-valve manifolds, which consolidate three or five bonnet assemblies into a single block, are primarily used in applications requiring Differential Pressure Transmitters, Gauges, and/or Chart Recorders, predominantly for flow measurement purposes. In certain circumstances, differential pressure measurement can also be applied in other areas, such as level or filtration.

3-valve remote mount manifolds integrate three needle valves into a unitised block, providing isolation for the instrument impulse lines and an equalisation feature. This facilitates the installation and maintenance of remotely connected instruments.

3W Female x Female 1/2" NPT threaded connections - 6,000 PSI (414 Bar)

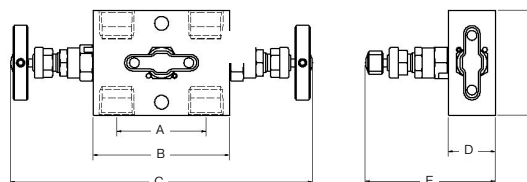
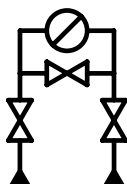

With the addition of downstream vent/drain/test ports these 3-valve remote mount manifolds are a cost effective alternative to a 5 valve manifold, where the application and conditions allow.

Material		Pressure PSig	Option		Dimension					
Stainless Steel	6MO		Gland	Tip	A	B	C	D	E	F
HLS3M	HL6M3M	6,000	PTFE	Std Hard	54.0 (2.13)	82.6 (3.25)	183.0 (7.21)	28.6 (1.13)	78.8 (3.11)	63.5 (2.50)
HLS3M3	HL6MO3M3	6,000	Graphite	Std Hard	54.0 (2.13)	82.6 (3.25)	183.0 (7.21)	28.6 (1.13)	78.8 (3.11)	63.5 (2.50)
HLS3MPK	HL6MOPK	6,000	PTFE	PEEK Tip	54.0 (2.13)	82.6 (3.25)	183.0 (7.21)	28.6 (1.13)	78.8 (3.11)	63.5 (2.50)

3W Female x Female 1/2" NPT threaded connections with additional 1/4" NPT Female Downstream Test Ports - 6,000 PSI (414 Bar)

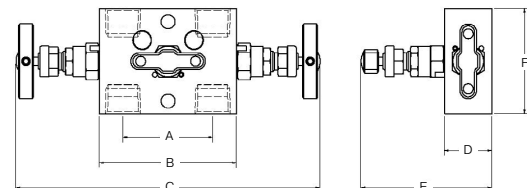
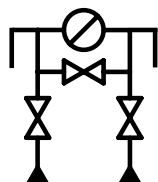
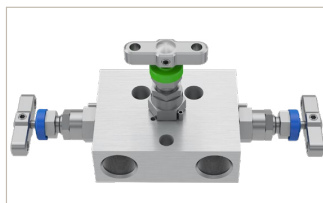

Material		Pressure PSig	Option		Dimension					
Stainless Steel	6MO		Gland	Tip	A	B	C	D	E	F
HLS3MDTP	HL6MODTP	6,000	PTFE	Std Hard	54.0 (2.13)	82.6 (3.25)	183.0 (7.21)	28.6 (1.13)	78.8 (3.11)	63.5 (2.50)
HLS3MDTP3	HL6MODTP3	6,000	Graphite	Std Hard	54.0 (2.13)	82.6 (3.25)	183.0 (7.21)	28.6 (1.13)	78.8 (3.11)	63.5 (2.50)
HLS3MDTPPK	HL6MODTPPK	6,000	PTFE	PEEK Tip	54.0 (2.13)	82.6 (3.25)	183.0 (7.21)	28.6 (1.13)	78.8 (3.11)	63.5 (2.50)

5-valve remote mount manifolds combine five needle valves into one unitised block to create Isolation for the instrument impulse lines and an Equalisation feature to assist in installation and maintenance of the remotely connected instrument(s). They also incorporate vent/drain or calibration valves and ports. These manifolds are suitable for use in many applications including those utilising Differential Pressure Gauges.

5W Female x Female 1/2" NPT threaded connections - 6,000 PSI (414 Bar)

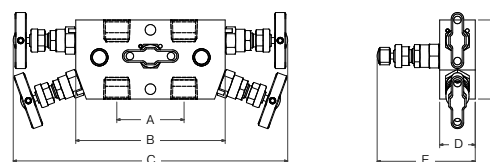
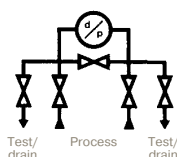
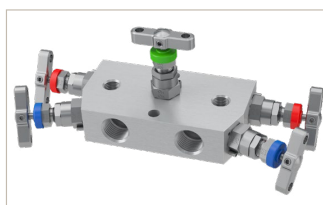

Material		Pressure PSig	Option		Dimension					
Stainless Steel	6MO		Gland	Tip	A	B	C	D	E	F
HLS5M	HL6MO5M	6,000	PTFE	Std Hard	54.0 (2.13)	120.0 (4.72)	221.6 (8.72)	28.6 (1.13)	79.4 (3.13)	63.5 (2.50)
HLS5M3	HL6MO5M3	6,000	Graphite	Std Hard	54.0 (2.13)	120.0 (4.72)	221.6 (8.72)	28.6 (1.13)	79.4 (3.13)	63.5 (2.50)
HLS5MPK	HL6MO5MPK	6,000	PTFE	PEEK TIP	54.0 (2.13)	120.0 (4.72)	221.6 (8.72)	28.6 (1.13)	79.4 (3.13)	63.5 (2.50)

NOTE: Graphite (3) packing and PEEK (PK) tip not available together.

Examples – How to specify the available options

¼" NPT Blank Plug (**P**) or Bleed Plug (**BV**) - For full details, see page 9.

Add the suffix **P** or **BV** within the part number, for example:

HLS3MP
HL6MO3MDTPBV
HLS5M3P

Mounting Bracket – Available separately or with manifold in Carbon Steel (**BK**) or stainless Steel (**BKS**). For full details, see page 24.

Add the suffix **BK** or **BKS** within the part number, for example:

HLS3MBK
HL6MO3MPBKBS
HLS5M3ATVBK

Anti Tamper operation (**AT**) – Vent valve and/or Equalise valve only – Available separately or with manifold, with or without key. For full details, see page 9.

Add the suffix **ATV**, **ATE** or **ATKV**, **ATEV** within the part number, for example:

HLS3MPATE
HL6MO3MDTPBVATKE
HLS5M3PATV

NACE MR0175 ISO15156 (**NC**) –

For full details, see page 6.

Add the suffix **NC** within the part number, for example:

HLS3MNC
HL6MO3MPBKSNK
HLS5M3BVATKVBKNC

Example – PEEK tip, Anti Tamper vent & Equalise with Key, Blank plug, Carbon Steel Bracket and NACE: **HL6MO5MPKPATKEVBKNC**

2, 3 & 5 Valve Manifolds - HD & HE Series

Direct mount

Combining two, three, or five bonnet assemblies into one block, the Parker **PREMIER** range 2, 3, and 5-valve manifolds are bolted directly to the measuring instrument through the DIN/IEC 61518 Type B bolted interface. The manifolds come with interface flange seals (PTFE or Graphite) as defined by the gland packing selection. Standard 2 or 4 7/16" UNF mounting bolts are also included. Optional stainless steel mounting bolts can be specified, as well as a selection of carbon or stainless steel brackets.

The 2-valve manifolds are specifically designed for use with directly connected absolute/gauge pressure transmitters for isolation, vent/drain calibration, and maintenance purposes.

The 3 and 5-valve manifolds are designed for use with differential pressure transmitters in flow and level measuring applications. With the addition of equalise capability and vent for the 5-valve, they create isolation for the impulse lines and provide additional functionality to install, maintain, and calibrate the instrument.

Recognising and understanding the direct mount transmitters*



Manifolds mount to this IEC compliant interface

- Pressure applications utilise 2-valve manifolds bolted with 2 bolts
- Differential applications utilise 3 or 5-valve manifolds bolted with 4 bolts

7/16" UNF mounting holes

Connection centres are 2 1/8" (54mm)

Bolt hole centres are 2 1/8" (54mm) x 1 5/8" (41mm)



Typical installation

* Not Emerson Coplanar™ types .
For Coplanar™ please see page 21.

2 W - Flat barstock, Pipe to flange with 1/2" NPT inlet connections and 1/4" NPT vent - 6,000 PSI (414 Bar)

AVAILABLE **PREMIER** SELECTION

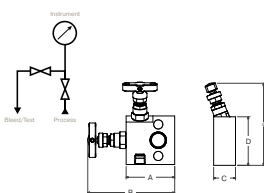

Material		Pressure PSIg	Option		Dimension				
Stainless Steel	6MO		Gland	Tip	A	B	C	D	E
HDS2M	HD6MO2M	6,000	PTFE	Std Hard	63.5 (2.50)	114.3 (4.50)	28.6 (1.13)	63.5 (2.50)	107.6 (4.24)
HDS2MPK	HD6MO2MPK	6,000	PTFE	PEEK Tip	63.5 (2.50)	114.3 (4.50)	28.6 (1.13)	63.5 (2.50)	107.6 (4.24)
HDS2MS	HD6MO2M3	6,000	Graphite	Std Hard	63.5 (2.50)	114.3 (4.50)	28.6 (1.13)	63.5 (2.50)	107.6 (4.24)

NOTE: Graphite **(3)** packing and PEEK **(PK)** tip not available together.

2 W - Flat barstock, Pipe to flange with 1/2" NPT inlet connections and 1/4" NPT vent - 6,000 PSI (414 Bar)

AVAILABLE **PREMIER** SELECTION

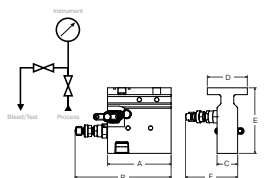

Material		Pressure PSIg	Option		Dimension					
Stainless Steel	6MO		Gland	Tip	A	B	C	D	E	F
HETS2	NOT AVAILABLE	6,000	PTFE	Std Hard	98.5 (3.88)	149.3 (5.88)	31.8 (1.25)	62.0 (2.44)	101.6 (4.00)	80.7 (3.18)
HETS2PK	NOT AVAILABLE	6,000	PTFE	PEEK Tip	98.5 (3.88)	149.3 (5.88)	31.8 (1.25)	62.0 (2.44)	101.6 (4.00)	80.7 (3.18)
HETS23	NOT AVAILABLE	6,000	Graphite	Std Hard	98.5 (3.88)	149.3 (5.88)	31.8 (1.25)	62.0 (2.44)	101.6 (4.00)	80.7 (3.18)

2 W - Extruded section, Flange to flange with 1/2" NPT inlet connections and 1/4" NPT vent - 6,000 PSI

AVAILABLE **PREMIER** SELECTION

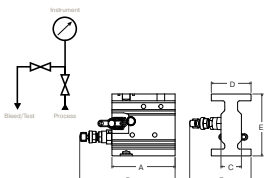
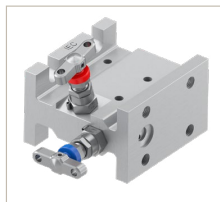

Material		Pressure PSIg	Option		Dimension					
Stainless Steel	6MO		Gland	Tip	A	B	C	D	E	F
HEHS2	NOT AVAILABLE	6,000	PTFE	Std Hard	98.5 (3.88)	149.3 (5.88)	31.8 (1.25)	62.0 (2.44)	96.4 (3.80)	95.8 (3.77)
HEHS2PK	NOT AVAILABLE	6,000	PTFE	PEEK Tip	98.5 (3.88)	149.3 (5.88)	31.8 (1.25)	62.0 (2.44)	96.4 (3.80)	95.8 (3.77)
HEHS23	NOT AVAILABLE	6,000	Graphite	Std Hard	98.5 (3.88)	149.3 (5.88)	31.8 (1.25)	62.0 (2.44)	96.4 (3.80)	95.8 (3.77)

NOTE: Graphite **(3)** packing and PEEK **(PK)** tip not available together.

3 W - Flat barstock. Pipe to flange with 1/2" NPT inlet connections - 6,000 PSI (414 Bar)

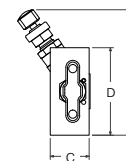
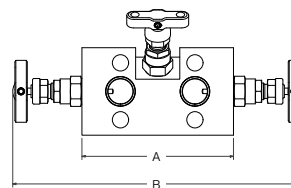
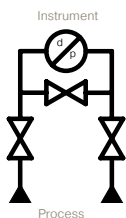
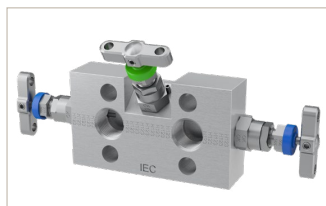

AVAILABLE **PREMIER** SELECTION

Material		Pressure PSIg	Option		Dimension				
Stainless Steel	6MO		Gland	Tip	A	B	C	D	E
HDS3MA	HD6MO3MA	6,000	PTFE	Std Hard	110.0 (4.33)	211.6 (8.33)	28.6 (1.13)	63.5 (.50)	91.0 (3.50)
HDS3MAPK	HD6MO3MAPK	6,000	PTFE	PEEK Tip	110.0 (4.33)	211.6 (8.33)	28.6 (1.13)	63.5 (.50)	91.0 (3.50)
HDS3MA3	HD6MO3MA3	6,000	Graphite	Std Hard	110.0 (4.33)	211.6 (8.33)	28.6 (1.13)	63.5 (.50)	91.0 (3.50)

3 W - Extruded section, Pipe to flange with 1/2" NPT inlet connections - 6,000 PSI (414 Bar)

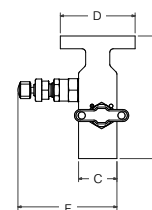
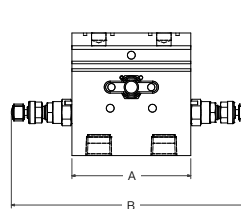
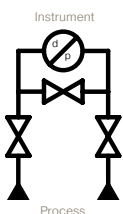

AVAILABLE **PREMIER** SELECTION

Material		Pressure PSIg	Option		Dimension					
Stainless Steel	6MO		Gland	Tip	A	B	C	D	E	F
HETS3	NOT AVAILABLE	6,000	PTFE	Std Hard	98.5 (3.88)	200.1 (7.88)	31.8 (1.25)	62.0 (2.44)	101.6 (4.00)	82.6 (3.25)
HETS3PK	NOT AVAILABLE	6,000	PTFE	PEEK Tip	98.5 (3.88)	200.1 (7.88)	31.8 (1.25)	62.0 (2.44)	101.6 (4.00)	82.6 (3.25)
HETS33	NOT AVAILABLE	6,000	Graphite	Std Hard	98.5 (3.88)	200.1 (7.88)	31.8 (1.25)	62.0 (2.44)	101.6 (4.00)	82.6 (3.25)

3 W - Extruded section, Flange to flange - 6,000 PSI (414 Bar)

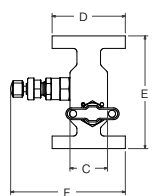
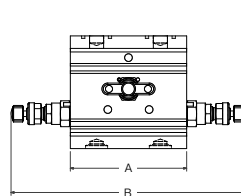
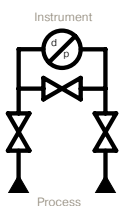
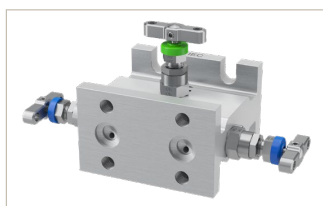

AVAILABLE **PREMIER** SELECTION

Material		Pressure PSIg	Option		Dimension					
Stainless Steel	6MO		Gland	Tip	A	B	C	D	E	F
HEHS3	NOT AVAILABLE	6,000	PTFE	Std Hard	98.5 (3.88)	200.1 (7.88)	31.8 (1.25)	62.0 (2.44)	96.4 (3.80)	97.7 (3.85)
HEHS3PK	NOT AVAILABLE	6,000	PTFE	PEEK Tip	98.5 (3.88)	200.1 (7.88)	31.8 (1.25)	62.0 (2.44)	96.4 (3.80)	97.7 (3.85)
HEHS33	NOT AVAILABLE	6,000	Graphite	Std Hard	98.5 (3.88)	200.1 (7.88)	31.8 (1.25)	62.0 (2.44)	96.4 (3.80)	97.7 (3.85)

NOTE: Graphite (3) packing and PEEK (PK) tip not available together.

5 W - Flat barstock. Pipe to flange (2.125" Ctrs) with 1/2" NPT inlet connections and 1/4" NPT vent/drain ports - 6,000 PSI (414 Bar)

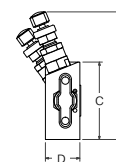
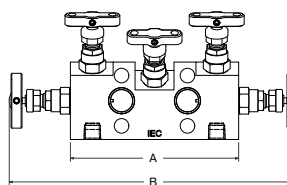
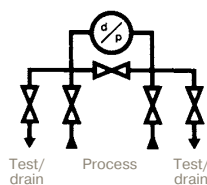
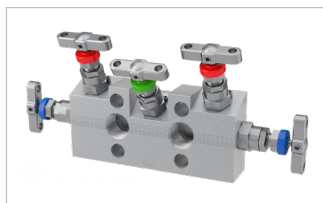

AVAILABLE **PREMIER** SELECTION

Material		Pressure PSIg	Option		Dimension				
Stainless Steel	6MO		Gland	Tip	A	B	C	D	E
HDS5MA	HD6MO5MA	6,000	PTFE	Std Hard	130.0 (5.43)	239.6 (9.43)	63.5 (2.50)	28.6 (1.13)	107.6 (4.24)
HDS5MAPK	HD6M53MAPK	6,000	PTFE	PEEK Tip	130.0 (5.43)	239.6 (9.43)	63.5 (2.50)	28.6 (1.13)	107.6 (4.24)
HDS5MA3	HD6MO5MA3	6,000	Graphite	Std Hard	130.0 (5.43)	239.6 (9.43)	63.5 (2.50)	28.6 (1.13)	107.6 (4.24)

NOTE: Graphite (3) packing and PEEK (PK) tip not available together.

5 W - Flat barstock. Pipe to flange (extended centres) with 1/2" NPT inlet connections and 1/4" NPT vent/drain - 6,000 PSI (414 Bar)

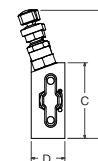
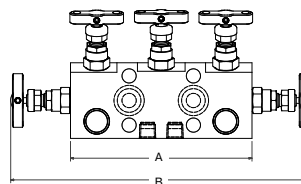
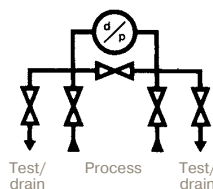

AVAILABLE **PREMIER** SELECTION

Material		Pressure PSI _g	Option		Dimension				
Stainless Steel	6MO		Gland	Tip	A	B	C	D	E
HDS5	HD6MO5	6,000	PTFE	Std Hard	152.4 (6.00)	254.0 (10.0)	63.5 (2.50)	28.6 (1.13)	107.6 (4.24)
HDS5PK	HD6MO5PK	6,000	PTFE	PEEK Tip	152.4 (6.00)	254.0 (10.0)	63.5 (2.50)	28.6 (1.13)	107.6 (4.24)
HDS53	HD6MO53	6,000	Graphite	Std Hard	152.4 (6.00)	254.0 (10.0)	63.5 (2.50)	28.6 (1.13)	107.6 (4.24)

5 W— Flat barstock. Pipe to flange (extended centres) with 1/2" NPT inlet connections and 1/4" NPT vent/drain specifically for fiscal metering.

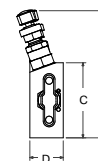
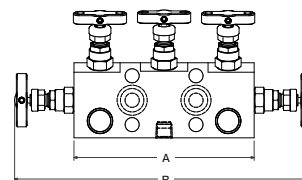
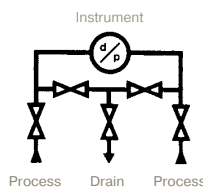
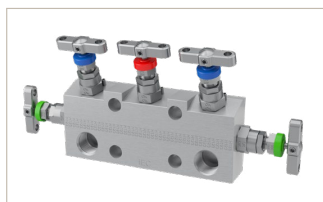

AVAILABLE **PREMIER** SELECTION

Material		Pressure PSI _g	Option		Dimension				
Stainless Steel	6MO		Gland	Tip	A	B	C	D	E
HDS5CT	HD6MO5CT	6,000	PTFE	Std Hard	152.4 (6.00)	254.0 (10.0)	63.5 (2.50)	28.6 (1.13)	107.6 (4.24)
HDS5CTPK	HD6MO5CTPK	6,000	PTFE	PEEK Tip	152.4 (6.00)	254.0 (10.0)	63.5 (2.50)	28.6 (1.13)	107.6 (4.24)
HDS5CT3	HD6MO5CT3	6,000	Graphite	Std Hard	152.4 (6.00)	254.0 (10.0)	63.5 (2.50)	28.6 (1.13)	107.6 (4.24)

5 W - Extruded section. Pipe to flange with 1/2" NPT inlet connections and 1/4" NPT vent/drain ports - 6,000 PSI (414 Bar)

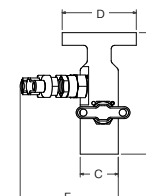
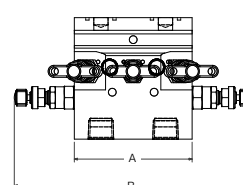
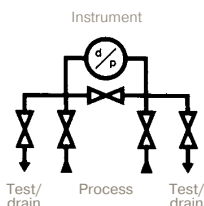

AVAILABLE **PREMIER** SELECTION

Material		Pressure PSI _g	Option		Dimension					
Stainless Steel	6MO		Gland	Tip	A	B	C	D	E	F
HETS5	NOT AVAILABLE	6,000	PTFE	Std Hard	98.5 (3.88)	200.1 (7.88)	31.8 (1.25)	62.0 (2.44)	101.6 (4.00)	82.6 (3.25)
HETS5PK	NOT AVAILABLE	6,000	PTFE	PEEK Tip	98.5 (3.88)	200.1 (7.88)	31.8 (1.25)	62.0 (2.44)	101.6 (4.00)	82.6 (3.25)
HETS53	NOT AVAILABLE	6,000	Graphite	Std Hard	98.5 (3.88)	200.1 (7.88)	31.8 (1.25)	62.0 (2.44)	101.6 (4.00)	82.6 (3.25)

NOTE: Graphite **(3)** packing and PEEK **(PK)** tip not available together.

5 WV - Extruded section. Flange to flange with 1/2" NPT inlet connections and 1/4" NPT vent/drain ports - 6,000 PSI (414 Bar)

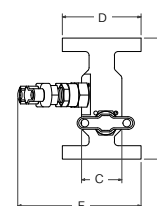
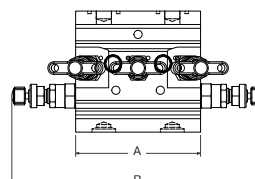
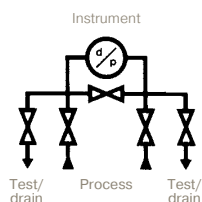
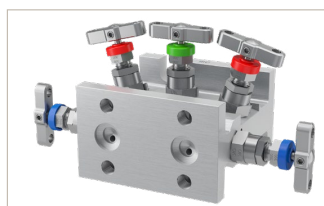

AVAILABLE **PREMIER** SELECTION

Material		Pressure PSIg	Option		Dimension					
Stainless Steel	6MO		Gland	Tip	A	B	C	D	E	F
HEHS5	NOT AVAILABLE	6,000	PTFE	Std Hard	98.5 (3.88)	200.1 (7.88)	31.8 (1.25)	62.0 (2.44)	96.4 (3.80)	97.7 (3.85)
HEHS5PK	NOT AVAILABLE	6,000	PTFE	PEEK Tip	98.5 (3.88)	200.1 (7.88)	31.8 (1.25)	62.0 (2.44)	96.4 (3.80)	97.7 (3.85)
HEHS53	NOT AVAILABLE	6,000	Graphite	Std Hard	98.5 (3.88)	200.1 (7.88)	31.8 (1.25)	62.0 (2.44)	96.4 (3.80)	97.7 (3.85)

NOTE: Graphite **(3)** packing and PEEK **(PK)** tip not available together.

Examples – How to specify the available options

1/4" NPT Blank Plug **(P)** or Bleed Plug **(BV)** - For full details, see page 9.

Add the suffix **P** or **BV** within the part number, for example:

HDS3MAP
HD6MO5MABV
HETS53P

Mounting Bracket – Available separately or with manifold in Carbon Steel **(BK)** or stainless Steel **(BKS)**. For full details, see pages 25 and 26.

Add the suffix **BK** or **BKS** within the part number, for example:

HDS3MABK
HD6MO5MAPBKS
HETS53ATKEBK

Anti Tamper operation **(AT)** – Vent valve and/or Equalise Valve only. Available separately or with manifold, with or without key. For full details, see page 9.

Add the suffix **ATV**, **ATE** or **ATKV**, **ATEV** within the part number, for example:

HDS3MAPATE
HD6MO5MBVATKE
HETS53PATV

NACE MR0175 ISO15156 **(NC)** – For full details, see page 6.

Add the suffix **NC** within the part number, for example:

HDS3MABKNC
HD6MO5MAPBKSNC
HETS53ATKVBKNC

Example: PEEK tip, Anti Tamper vent & Equalise with Key, Blank plug, Carbon Steel Bracket and NACE: **HETS5PKPATKEVBKNC**

NOTE: HD & HE series manifolds are also available with the option of stainless steel transmitter mounting bolts **(SB)**. Please insert suffix **(SB)** within part number as shown below.

Example: Stainless Steel bolts, PEEK tip, Anti Tamper vent & Equalise with Key, Blank plug, Carbon Steel Bracket and NACE: **HDS5MASBPKPATKEVBKNC**

Example: Stainless Steel bolts, Graphite, Anti Tamper vent & Equalise with Key, Blank plug, Stainless Steel Bracket and NACE: **HDS5MASB3PATKEVBKSNC**

2, 3 & 5 Valve Manifolds for 2051/3051 Coplanar™ Transmitters

These are the only direct mount manifolds in the range not to comply with the IEC standard. These Parker 'integral' style manifolds are uniquely designed for connection to the non-traditional Emerson/ Rosemount™ Coplanar™ transmitter models and are not suitable for use with the traditional IEC compliant models of this, or other brands.

In this scenario, the assembled manifold/transmitter combination has the advantage of more compact overall dimensions and reduced weight.

Typically, these assemblies are wall-mounted or mounted utilising a 2" NB pipestand. Compatibility of the Parker integral manifold is assured, having been designed and rigorously tested with all the Emerson/Rosemount™ Coplanar™ transmitters, such as 2051 and 3051 models.

Recognising and understanding the direct mount transmitters.



3051 DP transmitter, shown with the Emerson flange adapter in lieu of a manifold. A directly mounted Parker Coplanar™ manifold, replaces this.

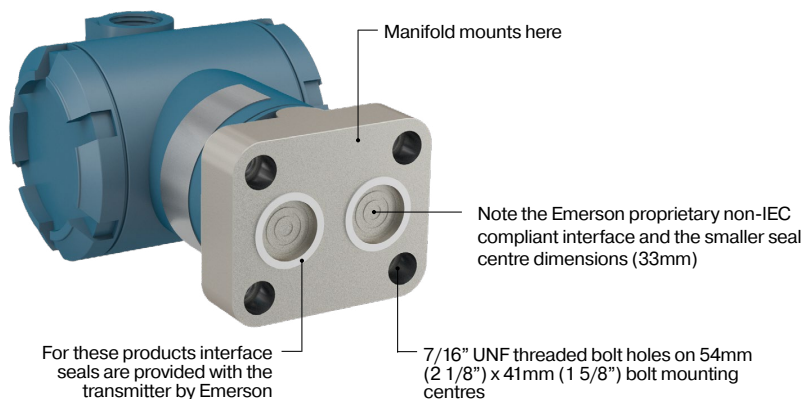

3051 DP transmitter, shown with the Emerson flange adapter removed.

2 WV - Pipe to flange with 1/2" NPT inlet connections and 1/4" NPT vent - 6,000 PSI (414 Bar)

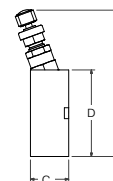
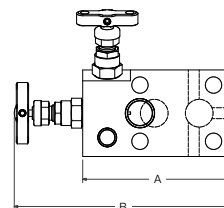
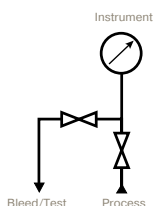
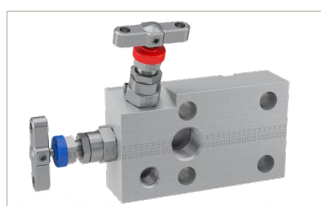

AVAILABLE PREMIER SELECTION

Material		Pressure PSig	Option		Dimension				
Stainless Steel	6MO		Gland	Tip	A	B	C	D	E
HDS2MCP	HD5MO2MCP	6,000	PTFE	Std Hard	110.0 (4.33)	160.8 (6.33)	28.6 (1.13)	63.5 (2.50)	107.6 (4.24)
HDS2MCPPK	HD6MO2MCPPK	6,000	PTFE	PEEK Tip	110.0 (4.33)	160.8 (6.33)	28.6 (1.13)	63.5 (2.50)	107.6 (4.24)
HDS2MCP3	HD6MO2MCP3	6,000	Graphite	Std Hard	110.0 (4.33)	160.8 (6.33)	28.6 (1.13)	63.5 (2.50)	107.6 (4.24)

NOTE: Graphite (3) packing and PEEK (PK) tip not available together.

3 W - Pipe to flange with 1/2" NPT inlet connections - 6,000 PSI (414 Bar)

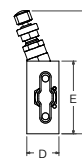
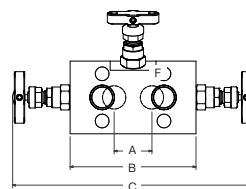
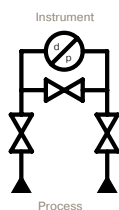
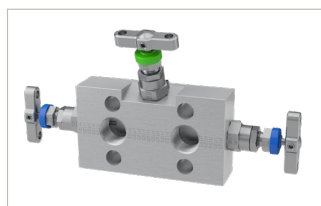

AVAILABLE **PREMIER** SELECTION

Material		Pressure PSI _g	Option		Dimension					
Stainless Steel	6MO		Gland	Tip	A	B	C	D	E	F
HDS3MCP	HD6MO3MCP	6,000	PTFE	Std Hard	33.0 (1.30)	110.0 (4.33)	211.6 (8.33)	28.6 (1.13)	63.5 (2.50)	107.6 (4.24)
HDS3MCPPK	HD6MO3MCPPK	6,000	PTFE	PEEK Tip	33.0 (1.30)	110.0 (4.33)	211.6 (8.33)	28.6 (1.13)	63.5 (2.50)	107.6 (4.24)
HDS3MCP3	HD6MO3M3	6,000	Graphite	Std Hard	33.0 (1.30)	110.0 (4.33)	211.6 (8.33)	28.6 (1.13)	63.5 (2.50)	107.6 (4.24)

5 W - Pipe to flange with 1/2" NPT inlet connections and 1/4" NPT vent/drains - 6,000 PSI

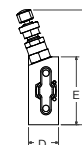
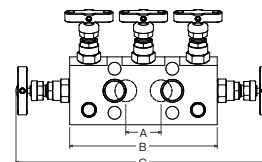
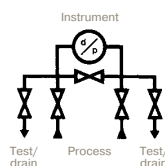
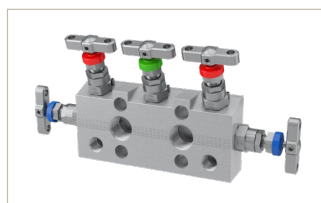

AVAILABLE **PREMIER** SELECTION

Material		Pressure PSI _g	Option		Dimension					
Stainless Steel	6MO		Gland	Tip	A	B	C	D	E	F
HDS5MCP	HD6MO5MCP	6,000	PTFE	Std Hard	33.0 (1.30)	138.0 (5.43)	239.6 (9.43)	28.6 (1.13)	63.5 (2.50)	107.6 (4.24)
HDS5MCPPK	HD6MO5MCPPK	6,000	PTFE	PEEK Tip	33.0 (1.30)	138.0 (5.43)	239.6 (9.43)	28.6 (1.13)	63.5 (2.50)	107.6 (4.24)
HDS5MCP3	HD6MO5M3	6,000	Graphite	Std Hard	33.0 (1.30)	138.0 (5.43)	239.6 (9.43)	28.6 (1.13)	63.5 (2.50)	107.6 (4.24)

Mounting Brackets

Brackets for remote/line mount manifolds and gauge valves

It is crucial to fully support impulse/pressure measurement tubing lines, manifolds, and instruments. That is why all Parker manifolds are designed to accommodate bracket mounting and support. We offer a full range of bracket mounting kits, which can either be supplied fully assembled to the manifolds or provided separately for on-site installation.

Available in both all-carbon and all-stainless steel variants, these kits are specifically tailored to fit Parker manifolds. They ensure the necessary clearance for efficient operation of all handles and are designed to provide maximum rigidity and support. Whether oriented horizontally or vertically, these brackets can be mounted on panels, walls, or 2" NB pipe stands.

Brackets for 2-valve remote mount manifolds - BKT1

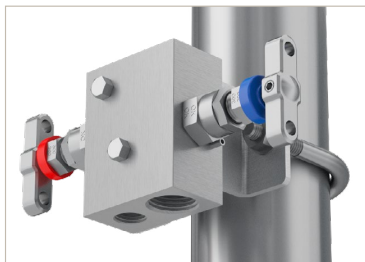

Image shown: Part No.: **HLS2VBK**

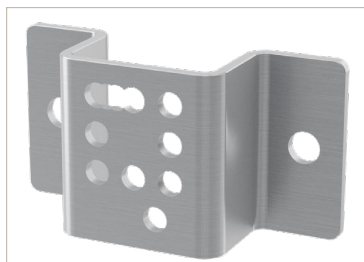
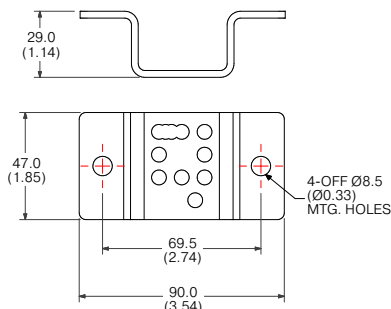

Image shown: Part No.: **BKT1SSB1**



How to order:

Item	Part Number		Suitable for Manifold Type
	Bracket material: Carbon Steel	Bracket material: Stainless Steel	
Bracket with M8 'U' Bolt and manifold Bolt Kit (Nuts and washers: M5 x 45 Bolt (2-OFF))	BKT1CSB1	BKT1SSB1	HL*2V HL*2V8M8F4F HAL*2V

Brackets for 2-valve remote mount manifolds and 3-valve DBB manifolds - BKT2

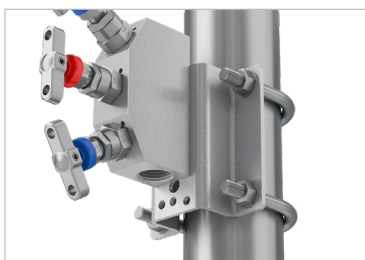
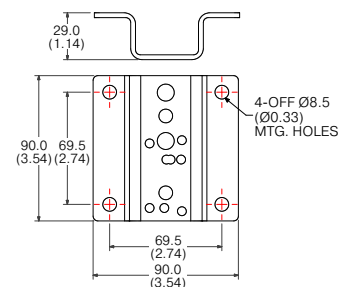

Image shown: Part No.: **HLS3DBBK**



Image shown: Part No.: **BKT2SSB2**



Item	Part Number		Suitable for Manifold Type
	Bracket material: Carbon Steel	Bracket material: Stainless Steel	
Bracket with M8 'U' Bolts and manifold Bolt Kit (Nuts and washers: M5 x 45 Bolt (2-OFF))	BKT2CSB1	BKT2SSB1	HAL*2VHP
Bracket with M8 'U' Bolts and manifold Bolt Kit (Nuts and washers: M10 x 12 Bolt (2-OFF))	BKT2CSB2	BKT2SSB2	HL*3DBB

'U' bolt with nuts and washers for 2" NB standpipe



Bracket kits include U bolts with nuts and washers.

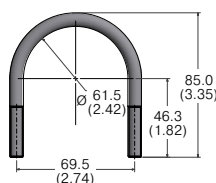

Mounting Brackets

Brackets for remote/line mount manifolds and gauge valves

Brackets for 3 and 5-valve remote mount manifolds - BKT2

- Universal manifold mounting bracket, suitable for all remote mount manifolds
- Allows 90 degree positioning enabling total installation flexibility and prevents handle obstruction
- Can be wall, standpipe or base mounted

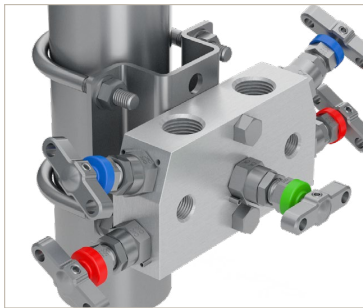
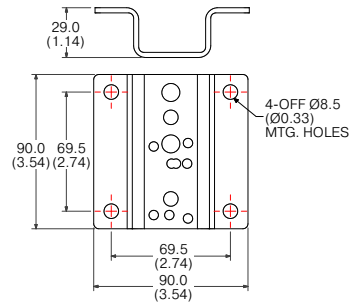

Image shown: Part No.: **HLS5MBK**



Image shown: Part No.: **BKT2SSB5**



How to order:

Item	Part Number		Suitable for Manifold Type
	Bracket material: Carbon Steel	Bracket material: Stainless Steel	
Bracket with M8 'U' Bolt and manifold Bolt Kit (Nuts and washers: M8 x 45 Bolt (2-OFF))	BKT2CSB5	BKT2SSB5	HL*3M HL*3MDTP HL*5M

'U' bolt with nuts and washers for 2" NB standpipe



Bracket kits include U bolts with nuts and washers.

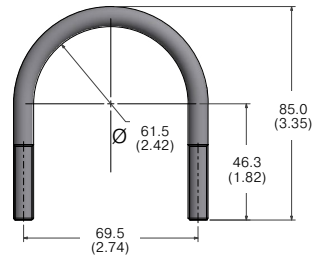

Mounting Brackets

Brackets for direct mount manifolds

Brackets for 2, 3 and 5-valve direct mount manifolds - BKT3

- Universal manifold mounting bracket, suitable for all direct mount manifolds
- This bracket design enables horizontal or vertical instrument positioning.



Image shown: Part No.: **HDS2MBK**



Image shown: Part No.: **HDS3MABK**

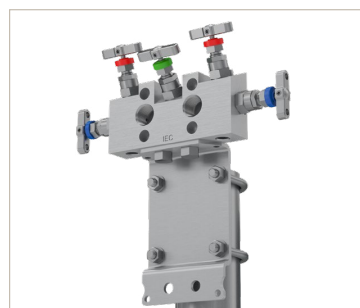
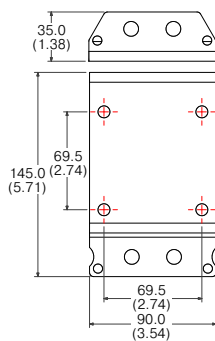

Image shown: Part No.: **HDS5MABK**



Image shown: Part No.: **BKT3CSB2**



How to order:

Item	Part Number		Suitable for Manifold Type	
	Bracket material: Carbon Steel	Bracket material: Stainless Steel	2-valve	3 & 5-valve
Bracket with M8 'U' Bolts and manifold Bolt Kit (Nuts and washers: M10 x 12 Bolt (2-OFF))	BKT3CSB2	BKT3SSB2	HD*2M	HD*3MA HD*5MA

'U' bolt with nuts and washers for 2" NB standpipe



Bracket kits include U bolts with nuts and washers.

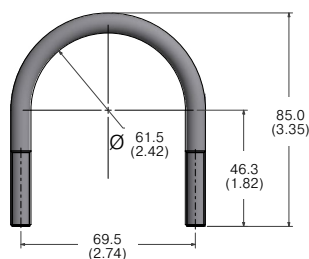

Brackets for 5-valve direct mount HD*5 style manifolds with increased process centres - BKT5

- Universal manifold mounting bracket, suitable for all direct mount manifolds
- This bracket design enables horizontal or vertical instrument positioning

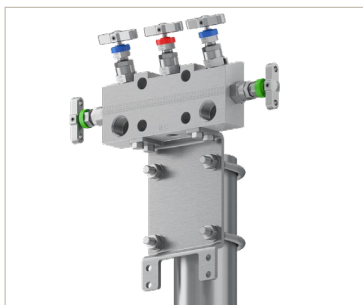
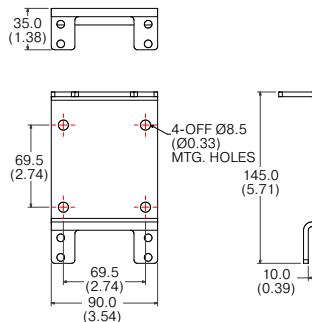

Image shown: Part No.: **HDS5BK**



Image shown: Part No.: **BKT5CSB6**



How to order:

Item	Part Number		Suitable for Manifold Type
	Bracket material: Carbon Steel	Bracket material: Stainless Steel	
Bracket with M8 'U' Bolts and manifold Bolt Kit (Nuts and washers: M6 x 12 Bolt (4-OFF))	BKT5CSB6	BKT5SSB6	HD*5CT HD*5

Brackets for 2, 3 and 5-valve direct mount extruded manifolds - BKT4

- Universal manifold mounting bracket, suitable for all direct mount extruded manifolds
- This bracket design enables horizontal or vertical instrument positioning.

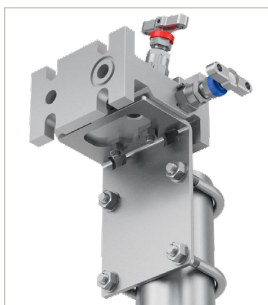

Image shown: Part No.: **HEHS2BK**



Image shown: Part No.: **HEHS5BK**



Image shown: Part No.: **BKT4CSB4**

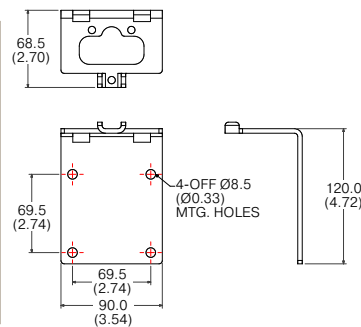

How to order:

Item	Part Number		Suitable for Manifold Type	
	Bracket material: Carbon Steel	Bracket material: Stainless Steel	2-valve	3 & 5-valve
Bracket with M8 'U' Bolt and manifold Bolt Kit (Nuts and washers: M6 x 45 Bolt (3-OFF))	BKT4CSB4	BKT4SSB4	HEH*2 HET*2	HET*3 HEH*3 HET*5 HEH*5

Mounting Brackets

Brackets for 2051/3051 Coplanar™ transmitter manifolds

Brackets for 2, 3 and 5-valve direct mount manifolds - BKT3

- Universal manifold mounting bracket, suitable for all direct mount manifolds
- This bracket design enables horizontal or vertical instrument positioning.

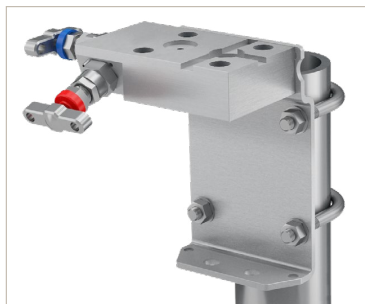

Image shown: Part No.: **HDS2MCPBK**



Image shown: Part No.: **HDS3MCPBK**

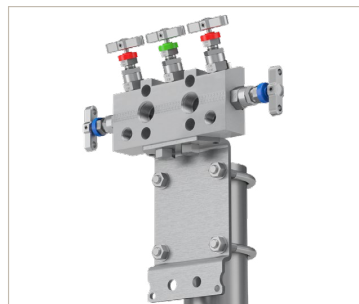
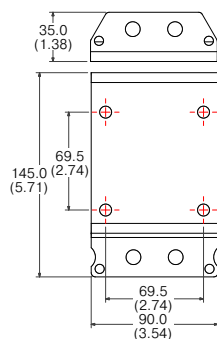

Image shown: Part No.: **HDS5MCPBK**



Image shown: Part No.: **BKT3SSB2**



How to order:

Item	Part Number		Suitable for Manifold Type	
	Bracket material: Carbon Steel	Bracket material: Stainless Steel	2-valve	3 & 5-valve
Bracket with M8 'U' Bolts and manifold Bolt Kit (Nuts and washers: M10 x 12 Bolt (2-OFF))	BKT3CSB2	BKT3SSB2	HD*2MCP	HD*3MCP HD*5MCP

European Product Information Centre
Free phone: 00 800 27 27 5374
(from AT, BE, CH, CZ, DE, DK, EE, ES, FI,
FR, IE, IL, IS, IT, LU, MT, NL, NO, PL, PT,
RU, SE, SK, UK, ZA)

© 2023 Parker Hannifin Corporation. All rights reserved.

Catalogue 4190-PREM 09.23



Parker Hannifin Manufacturing Ltd.
Instrumentation Products Division, Europe
Riverside Road
Barnstaple EX31 1NP
United Kingdom

phone 0044 (0)1271 313131
www.parker.com/ipd

Your local authorized Parker distributor