



aerospace  
climate control  
electromechanical  
filtration  
fluid & gas handling  
hydraulics  
**pneumatics**  
process control  
sealing & shielding



# Pneumatic Rotary Actuators

Series PRO - PRN

Catalogue PDE2502TCUK April 2011



ENGINEERING YOUR SUCCESS.

PDE2502TCUK

## Pneumatic Rotary Actuators - Series PRO - PRN



Rotary actuators are an efficient and easy way to generate torque from compressed air, in a very compact size. They are ideal for the compact applications in a wide range of industries such as, packaging, process, electronics etc.

### Wide range

A full range of 9 sizes is available, the 8 largest sizes are single or double vane type (with double effective torque). For the PRN High Torque, a series of customized cushion units (CRN) are available for high energy applications.

### Easy-to-use oscillating angles

Two oscillation reference points of 45° and 90° and three oscillating angles of 90° 180° and 270° are featured on the PRN ranges to match the most frequently uses. On the PRO range, the oscillation angle can be adjusted to the exact requirement.

### Stable operation

The unique sealing design minimises leakages. It assures low speed oscillation and stable, smooth operation even at low operating pressures and speeds.

### Durability to high operating temperatures

Dry dehumidified air may supply the rotary actuators within operating temperature range of -5°C to 80°C (PRN range -5°C to +60°C).

### Outstanding durability

A solid vane shaft and built-in damper are combined with a unique sealing design to ensure outstanding durability. PRN50 and higher models are able to operate much greater loads with the incorporation of a Hydro-cushion.

## Contents

General information.....	2
PRO Adjustable Oscillating Angle.....	4
PRN Miniature range .....	12
PRN High Torque range .....	20
CRN Hydro-cushion for PRN High Torque.....	25
Selecting a Rotary Actuator .....	28
Common instructions.....	30



#### Important !

Before attempting any external or internal work on the actuator or any connected component, make sure the actuator is vented and disconnect the air supply in order to ensure insulation of the air supply.



#### Note !

**Air quality is essential for maximum cylinder life (please refer to ISO 8573).**

#### Note !

**All technical data in this catalogue are typical data only.**



#### WARNING

**FAILURE OR IMPROPER SELECTION OR IMPROPER USE OF THE PRODUCTS AND/OR SYSTEMS DESCRIBED HEREIN OR RELATED ITEMS CAN CAUSE DEATH, PERSONAL INJURY AND PROPERTY DAMAGE.**

This document and other information from Parker Hannifin Corporation, its subsidiaries and authorized distributors provide product and/or system options for further investigation by users having technical expertise. It is important that you analyze all aspects of your application and review the information concerning the product or system in the current product catalog. Due to the variety of operating conditions and applications for these products or systems, the user, through its own analysis and testing, is solely responsible for making the final selection of the products and systems and assuring that all performance, safety and warning requirements of the application are met. The products described herein, including without limitation, product features, specifications, designs, availability and pricing, are subject to change by Parker Hannifin Corporation and its subsidiaries at any time without notice.

#### SALE CONDITIONS

The items described in this document are available for sale by Parker Hannifin Corporation, its subsidiaries or its authorized distributors. Any sale contract entered into by Parker will be governed by the provisions stated in Parker's standard terms and conditions of sale (copy available upon request).



PDE2502TCUK

## Pneumatic Rotary Actuators - Series PRO - PRN

### PRO Miniature Rotary Actuators (adjustable oscillating angle)

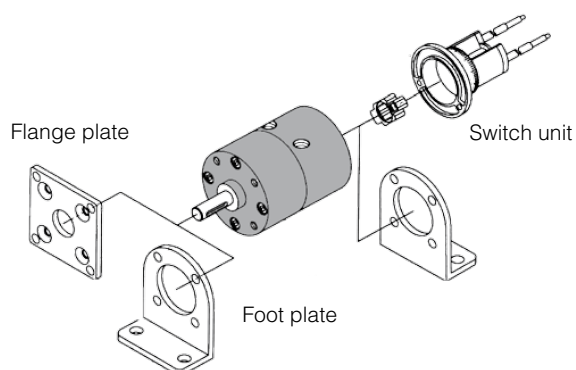

Vane	Model	Effective torque (N.cm at 6 bar)
Single vane	PROA3S	38
	PROA10S	120
	PROA20S	210
Double Vane	PRO30SE	410
	PROA3D	86
	PROA10D	254
	PROA20D	470
	PRO30DE	950

Refer page 4

### PRN Miniature Rotary Actuators (fixed oscillating angle)

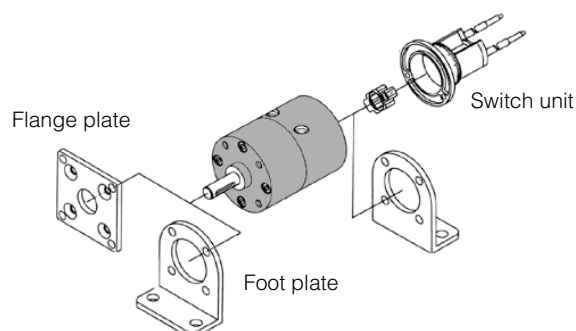

Vane	Model	Effective torque (N.cm at 6 bar)
Single vane	PRNA1S	15,6
	PRNA3S	38
	PRNA10S	120
	PRNA20S	210
Double Vane	PRN30SE	410
	PRNA1D	34,7
	PRNA3D	86
	PRNA10D	254
	PRNA20D	470
	PRN30DE	950

Refer page 12

### PRN High Torque (fixed oscillating angle)

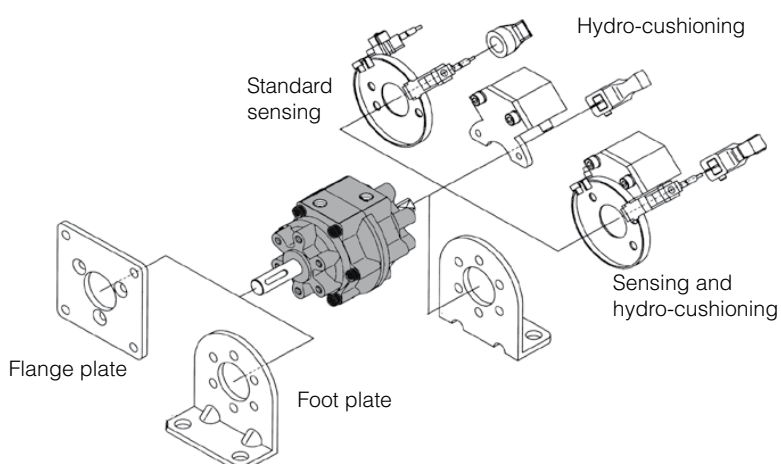

Vane	Model	Effective torque (N.cm at 6 bar)
Single vane	PRN50SE	590
	PRN150SE	1800
	PRN300SE	3450
Double Vane	PRN800SE	12300
	PRN50DE	1280
	PRN150DE	4150
	PRN300DE	8300
	PRN800DE	24700

Refer page 20

PDE2502TCUK

## Pneumatic Rotary Actuators - Series PRO - PRN

### PRO Miniature series - Adjustable oscillating angle - Order Codes

#### Standard models



Order code	Torque at 6 bar (N.cm)	Oscillating angle
<b>Single vane</b>		
PROA3S-0-90	38	30 to 180°
PROA10S-0-90	120	30 to 180°
PROA20S-0-90	210	30 to 180°
PRO30SE-0-45	410	30 to 270°
<b>Double vane</b>		
PROA3D-0-45	86	30 to 90°
PROA10D-0-45	254	30 to 90°
PROA20D-0-45	470	30 to 90°
PRO30DE-0-45	950	30 to 90°

How to select a PRO rotary actuator ? Refer page 28

**Note :** Rotary actuators with variable oscillating angle are shipped with fixed reference point stopper. The angle setting stopper is attached but not fixed. This must be fixed securely before use.

#### Oscillation starting point and oscillation angle

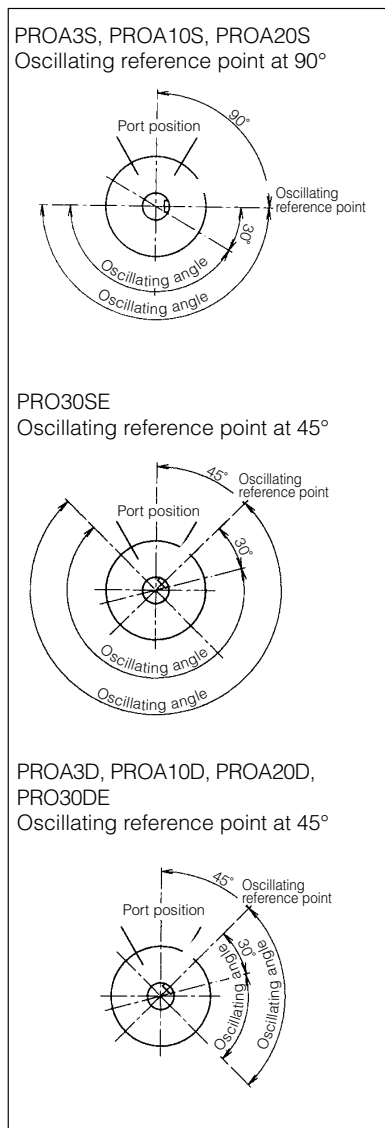

#### Rotary Actuator mountings

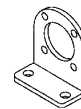
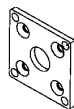

For Rotary Actuator	Flange mounting	Foot mounting
PROA3S/D	PRN3-P	PRN3-L
PROA10S/D	PRN10-P	PRN10-L
PROA20S/D	PRN20-P	PRN20-L
PRO30SE/DE	PRN30-P	PRN30-L

The mountings are provided with set screws

#### Switch units

Variable switch position, solid state NPN or PNP.  
Refer to page 5 for technical data.

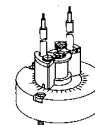

For Rotary Actuator	NPN	PNP
PROA3S/D	FR-3PRO	FP-3PRO
PROA10S/D	FR-10PRO	FP-10PRO
PROA20S/D	FR-20PRO	FP-20PRO
PRO30SE/DE	FR-30PRO	FP-30PRO

#### Protective cover and stopper unit

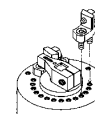

For Rotary Actuator	Protective cover	Stopper unit
PROA3S/D	PRO3-K	RO3-U
PROA10S/D	PRO10-K	RO10-U
PROA20S/D	PRO20-K	RO20-U
PRO30SE/DE	PRO30-K	RO30-U

#### Maintenance kits

The maintenance kit consists in the vane shaft, shoe seal and shaft O-rings

For Rotary Actuator	Single vane		Double vane	
PROA3S	PRNA3S-PS	PROA3D	PRNA3D-PS	
PROA10S	PRNA10S-PS	PROA10D	PRNA10D-PS	
PROA20S	PRNA20S-PS	PROA20D	PRNA20D-PS	
PRO30SE	PRN30S-PS	PRO30DE	PRN30D-PS	

PDE2502TCUK

## Pneumatic Rotary Actuators - Series PRO - PRN

### PRO Miniature series - Adjustable oscillating angle - Technical data

#### Technical specification

PRO Rotary Actuators	Unit	PROA3S	PROA10S	PROA20S	PRO30SE
Vane		Single vane			
Air condition		Filtered (5µ) lubricated or non-lubricated			
Oscillating angle	°	30 to 180	30 to 180	30 to 180	30 to 270
Oscillating reference point	°	90	90	90	45
Port size		M5	M5	M5	G1/8
Minimum operating pressure	bar	1,0	1,0	0,8	1,0
Operating pressure	bar	2 to 7	2 to 7	2 to 10	2 to 10
Operating temperature	°C	-5 to 80	-5 to 80	-5 to 80	-5 to 60
Maximum operating frequency	cycles/mn	150 (at 180°)	150 (at 180°)	120 (at 180°)	90 (at 270°)
Internal volume	cm <sup>3</sup>	4	12	21	43
Allowable radial load	N	40	50	300	400
Allowable thrust load	N	4	4	25	30
Allowable energy	mJ	1	2	3	7
Weight	kg	0,085	0,170	0,280	0,510

PRO Rotary Actuators	Unit	PROA3D	PROA10D	PROA20D	PRO30DE
Vane		Double vane			
Air condition		Filtered (5µ) lubricated or non-lubricated			
Oscillating angle	°	30 to 90	30 to 90	30 to 90	30 to 90
Oscillating reference point	°	45	45	45	45
Port size		M5	M5	M5	G1/8
Minimum operating pressure	bar	0,7	0,7	0,6	0,8
Operating pressure	bar	2 to 7	2 to 7	2 to 10	2 to 10
Operating temperature	°C	-5 to 80	-5 to 80	-5 to 80	-5 to 60
Maximum operating frequency	cycles/mn	240 (at 90°)	240 (at 90°)	180 (at 90°)	180 (at 90°)
Internal volume	cm <sup>3</sup>	2,8	8,1	15	34
Allowable radial load	N	40	50	300	400
Allowable thrust load	N	4	4	25	30
Allowable energy	mJ	1	2	3	7
Weight	kg	0,087	0,180	0,290	0,530

#### Notes :

- The allowable energy differs from that of PRN series.
- Maximum operating frequency is given at 5 bar operating pressure (unloaded).
- Make sure to use the PRO rotary actuators within the allowable energy. Check if the required energy is lower than the allowable energy. If not, use end stoppers directly on the load.
- The PRO with keyways are provided with keys.

#### Materials specification

PRO	PROA3, PROA10, PROA20	PRO30
Body	Aluminium alloy	Aluminium alloy
Solid vane shaft	Steel + resin + Hydr. Nitrile	Steel + resin + Nitrile
Shoe	Resin	Resin
Shoe seal	Hydrogenated Nitrile	Nitrile
O-ring	Hydrogenated Nitrile	Nitrile
Screws, claw, stoppers, locknut	Steel	Steel

#### Effective torque (N.cm)

Model n°	Operating pressure (bar)									
	2	3	4	5	6	7	8	9	10	
<b>Single vane</b>										
PROA3S	10	17	24	31	38	45	-	-	-	
PROA10S	35	56	75	98	120	139	-	-	-	
PROA20S	59	95	133	170	210	249	287	326	368	
PRO30SE	110	180	250	319	410	480	580	650	720	
<b>Double vane</b>										
PROA3D	25	39	54	71	86	101	-	-	-	
PROA10D	76	117	162	211	254	303	-	-	-	
PROA20D	140	222	306	388	470	553	633	717	807	
PRO30DE	270	440	600	770	950	1120	1299	1480	1660	

#### Switch units specification

Switch unit type	FR-	FP-
Application	Relay, PLC, IC circuit	
Output method	NPN	PNP
Mounting	Switch position adjustable	
Operating voltage	DC5-30V	DC10-30V
Operating current	5 to 200mA	5 to 200mA
Indicating lamp	Lights up at ON	
Consumption	20mA at 24V	14mA at 24V 10mA at 12V
		7mA at 12V 4mA at 5V
Max.leakage current	10 µA	
Internal voltage drop	1,5 V	
Average operating time	1 ms	
Shock resistance	490m/s <sup>2</sup>	
Operating temperature	5 to 60°C	
Protection	IP67	
Lead wire	1 m, 3 core, oil resistant	
Response range	23°±7°	
Hysteresis	Approx. 2°	

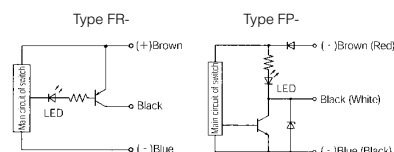

PDE2502TCUK

## Pneumatic Rotary Actuators - Series PRO - PRN

### PRO Miniature series - Adjustable oscillating angle - Technical data (cont)

#### Oscillating time range

Note : The PRO rotary actuators must be operated within the range of the charts shown; otherwise, they exhibit a stick-slip motion.

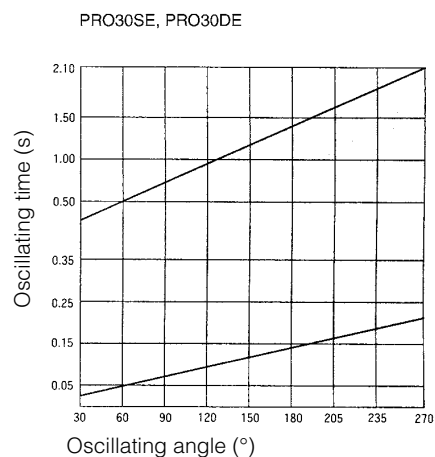
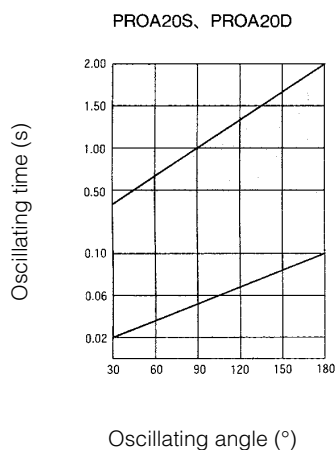
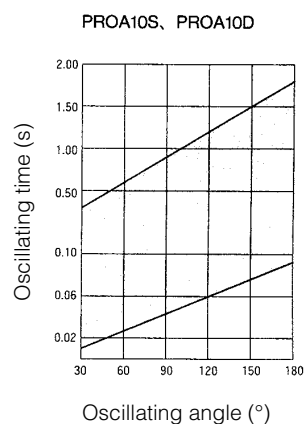
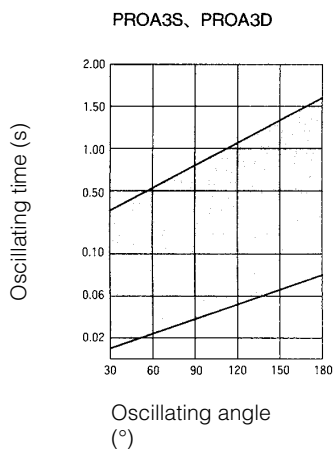

#### Setting the oscillation angle

The rotary actuators are delivered with the reference point stopper fixed and the angle setting stopper non fixed. The angle setting stopper has to be set in position according to the angle required, it can be attached at intervals of 15°.

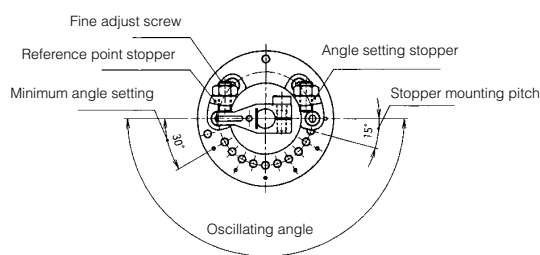

#### Oscillating angle setting and external stopper specifications

Model n°	PROA3S	PROA10S	PROA20S	PRO30SE	PROA3D	PROA10D	PROA20D	PRO30DE
Oscillation angle setting range	30 to 180°	30 to 180°	30 to 180°	30 to 270°	30 to 90°	30 to 90°	30 to 90°	30 to 90°
Oscillating reference point	90°	90°	90°	45°	45°	45°	45°	45°
Minimum angle setting	30°	30°	30°	30°	30°	30°	30°	30°
Maximum angle setting	180°	180°	180°	270°	90°	90°	90°	90°
Pitch for angle setting	15°	15°	15°	15°	15°	15°	15°	15°
<b>Fine adjustment range</b>								
Angle	-9° to +6°	-9° to +6°	-9° to +6°	-9° to +6°	-9° to +6°	-9° to +6°	-9° to +6°	-9° to +6°
Oscillating ref point	±3°	±3°	±3°	±3°	-1° to +3°	±3°	±3°	±3°
At max angle setting	-9° to +6°	-9° to +6°	-9° to +6°	-9° to +3°	-9° to +1°	-9° to +3°	-9° to +3°	-9° to +3°



PDE2502TCUK

## Pneumatic Rotary Actuators - Series PRO - PRN

### PRO Miniature series - Adjustable oscillating angle

#### Setting the oscillation angle (cont.)

##### When the angle setting equals the stopper mounting pitch (15°)

1. Place the stopper into the tapped hole corresponding to the intended angle and fix it. When mounting the stopper, use the angle setting marks provided every 30°, near the tapped hole.

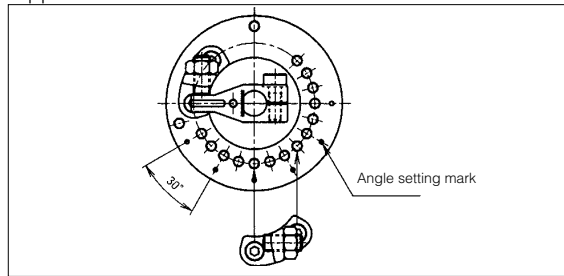

2. Then, rotate the fine adjust screws on the reference point stopper and the angle setting stopper until the correct angle is obtained. After completing the angle setting, the locknut must be tightened.

##### Angle fine adjustment range :

Refer to the table page 6.

#### Switch mounting orientation

The 2 types of switches (-3L and -3R) included in the switch unit have to be oriented in accordance to the table and diagrams herebelow :

Oscillating angle	Orientation of switches
30° to 186°	A
187° to 270°	B

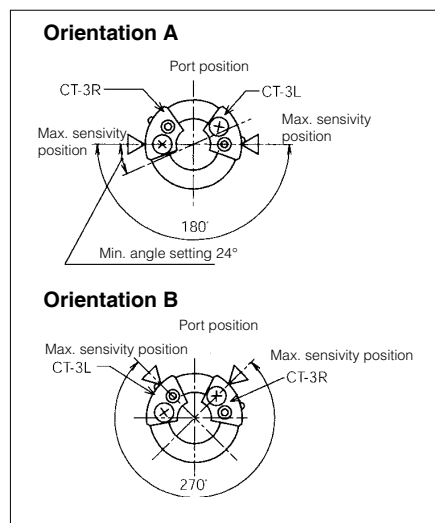

##### When the angle setting lies between two 15° stops

1. When the required angle lies between two 15° stops, fix the stopper into the tapped holes as shown in the diagram herebelow.

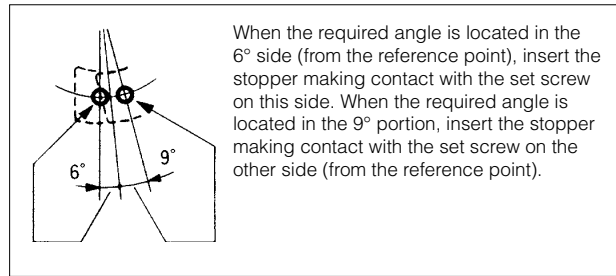

2. Then, rotate the fine adjust screw fitted to the stopper to obtain the required angle. After completing the angle setting, the locknut must be tightened.

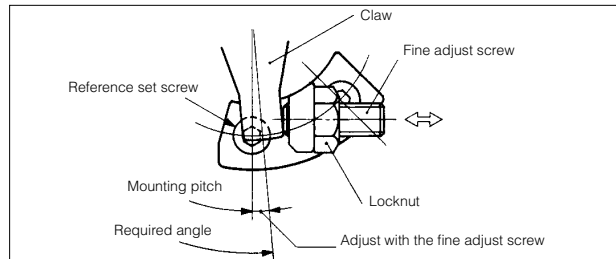

#### Setting the switch position

Mount the switch unit on the body using the set of screws. For clamping torque, refer to the table below

Model	Clamping torque (N.cm)
PROA3S/D	6 to 10
PROA10S/D	10 to 20
PROA20S/D and PRO30SE/DE	20 to 30

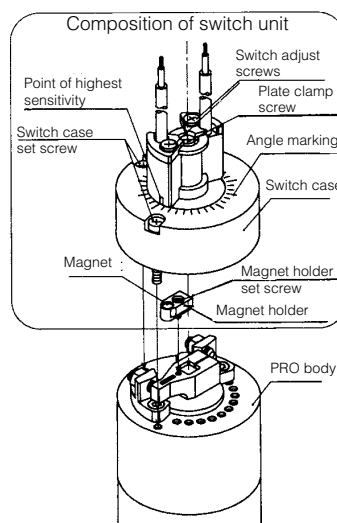

##### Adjusting the switch position

Loosen the switch adjust screws, make the point, at which the highest sensitivity is obtained, match with the angle marking equivalent to the actuator setting, and retighten the switch adjust screws torque of 40 to 50 N.cm. Since the angle markings are provided just for reference, make a final adjustment by checking if the LED is on.

##### Replacing the switch

To remove the switch, remove the switch adjust screws and plate clamp screw. To mount a switch, reverse the procedure for removal. Adjust the switch position after completion of mounting.

PDE2502TCUK

## Pneumatic Rotary Actuators - Series PRO - PRN

### PRO Miniature series - Adjustable oscillating angle - Dimensions (mm)

#### PROA3S

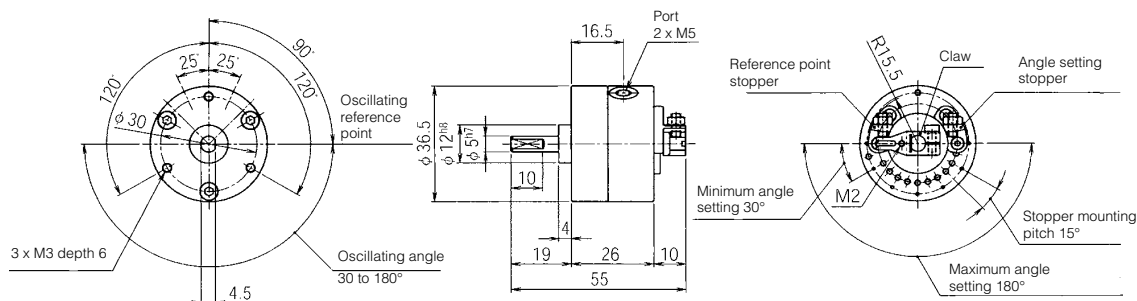

#### PROA3D

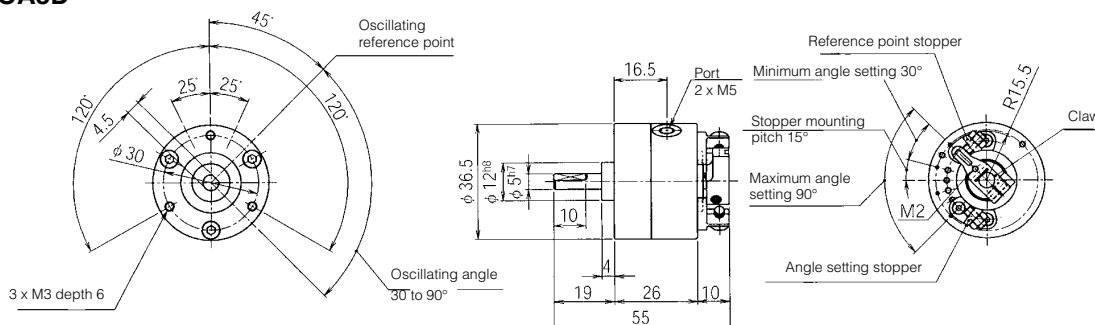

#### With protection cover

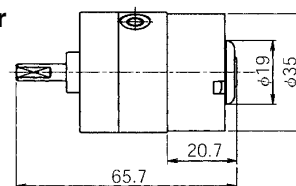

#### With foot plate mounting

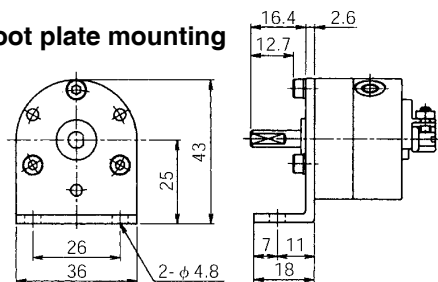

**Note :** A foot plate can be fitted turned by steps of 60° from the original position

#### With flange plate mounting

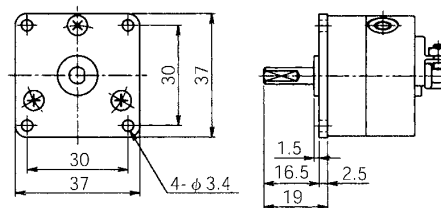

**Note :** A flange plate can be fitted turned by steps of 120° from the original position

#### With switch unit (variable switch position)

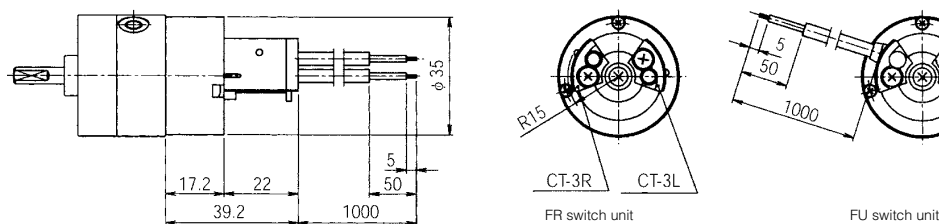

**Note :** For switch unit-mounting hardware combinations, refer to the required dimensions in each fig.

PDE2502TCUK

**Pneumatic Rotary Actuators - Series PRO - PRN**

**PRO Miniature series - Adjustable oscillating angle - Dimensions (mm)**

**PROA10S**

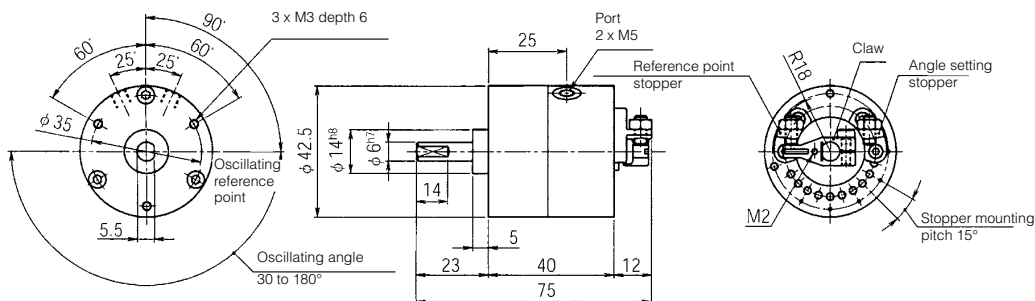

**PROA10D**

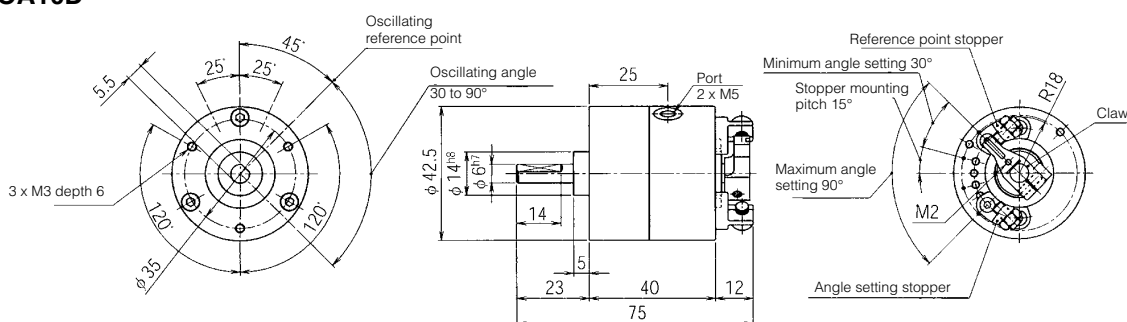

**With protection cover**

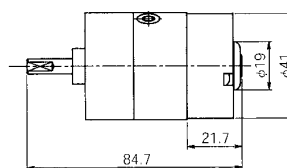

**With foot plate mounting**

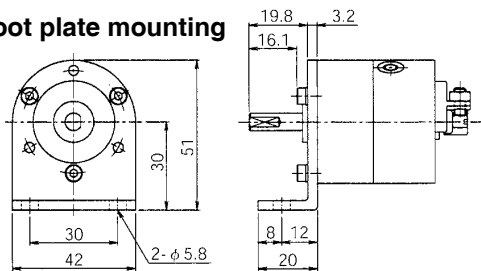

**Note :** A foot plate can be fitted turned by steps of 60° from the original position

**With flange plate mounting**

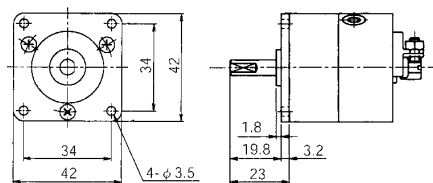

**Note :** A flange plate can be fitted turned by steps of 120° from the original position

**With switch unit (variable switch position)**

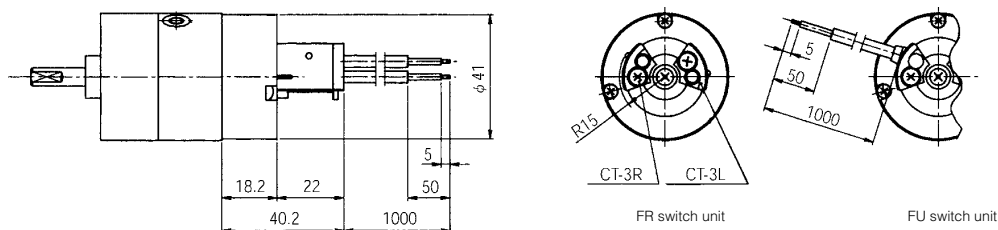

**Note :** For switch unit-mounting hardware combinations, refer to the required dimensions in each fig.



Parker Hannifin Corporation  
Pneumatic Division - Europe

PDE2502TCUK

## Pneumatic Rotary Actuators - Series PRO - PRN

### PRO Miniature series - Adjustable oscillating angle - Dimensions (mm)

#### PROA20S

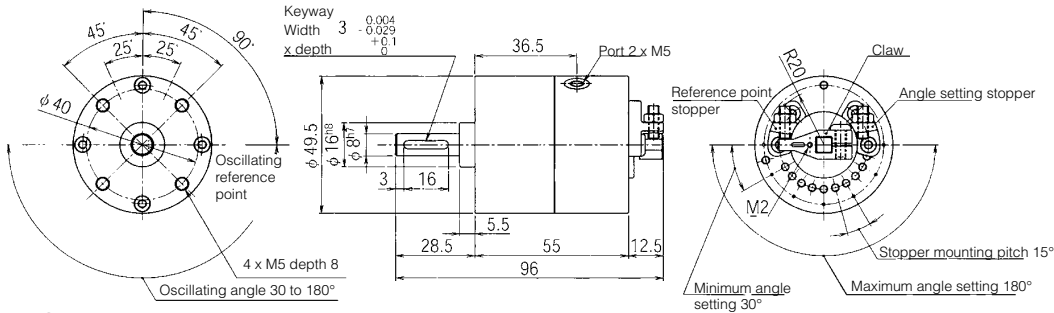

#### PROA20D

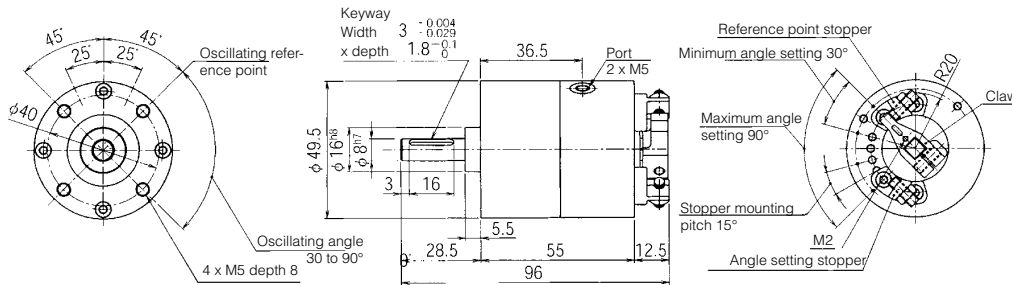

#### With protection cover

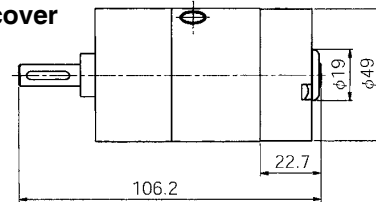

#### With foot plate mounting

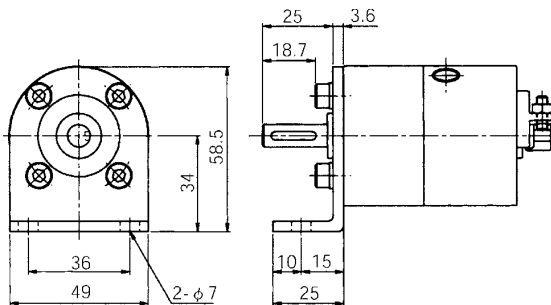

#### With flange plate mounting

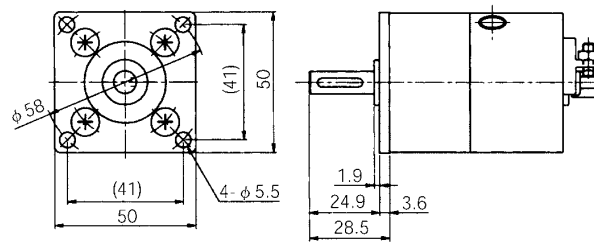

**Note :** A foot plate can be fitted turned by steps of 90° from the original position

#### With switch unit (variable switch position)

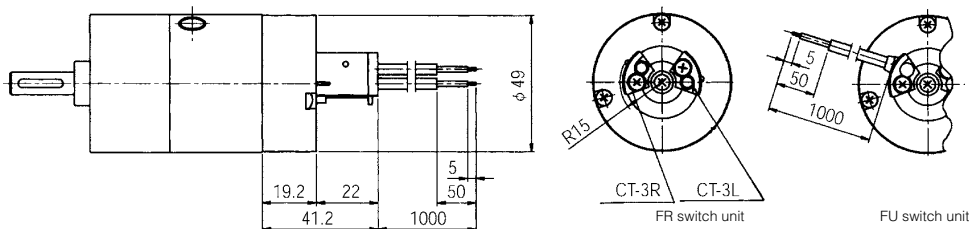

**Note :** For switch unit-mounting hardware combinations, refer to the required dimensions in each fig.

PDE2502TCUK

## Pneumatic Rotary Actuators - Series PRO - PRN

### PRO Miniature series - Adjustable oscillating angle - Dimensions (mm)

#### PROA30SE & DE

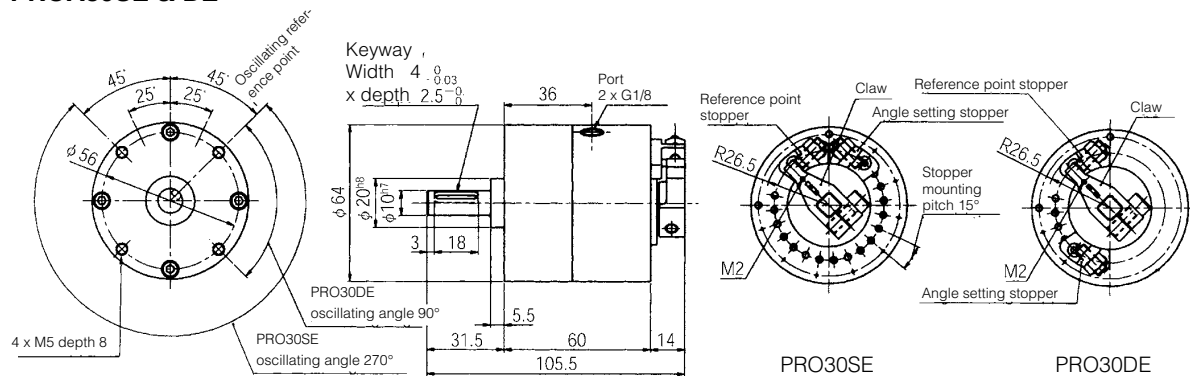

#### With protection cover

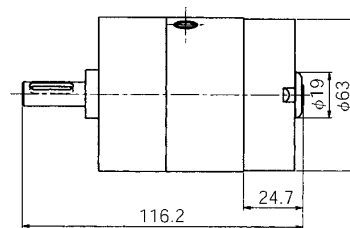

#### With foot plate mounting

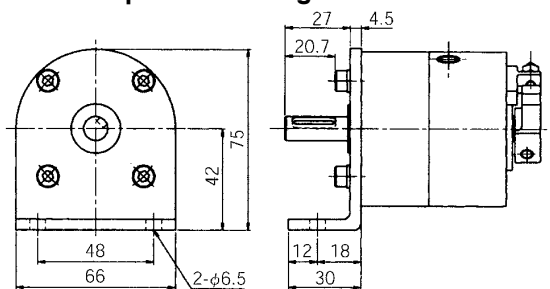

#### With flange plate mounting

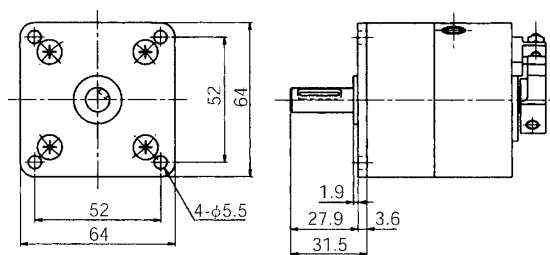

**Note :** A foot plate can be fitted turned by steps of 60° from the original position

#### With switch unit (variable switch position)

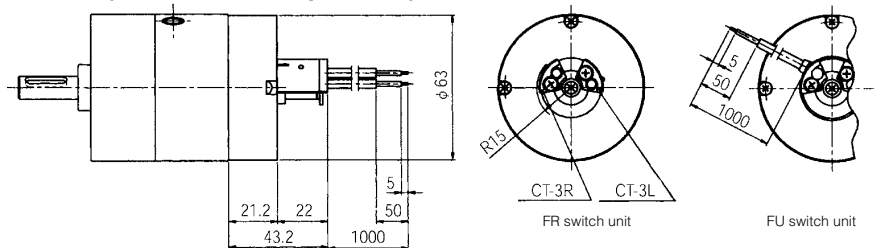

**Note :** For switch unit-mounting hardware combinations, refer to the required dimensions in each fig.



PDE2502TCUK

## Pneumatic Rotary Actuators - Series PRO - PRN

### PRN Miniature series - Fixed oscillating angle - Order Codes

#### Standard models



	Torque 6 bar	Oscillating angle			Oscillating reference point	
		90°	180°	270°	45°	90°
<b>Single vane (N.cm)</b>						
PRNA1S	15,6	PRNA1S-90-90	PRNA1S-180-90			X
PRNA3S	38	PRNA3S-90-90	PRNA3S-180-90			X
PRNA10S	120	PRNA10S-90-90	PRNA10S-180-90			X
PRNA20S	210	PRNA20S-90-90	PRNA20S-180-90			X
PRN30SE	410	PRN30SE-90-45	PRN30SE-180-45	PRN30SE-270-45	X	
<b>Double vane</b>						
PRNA1D	34,7	PRNA1D-90-45				X
PRNA3D	86	PRNA3D-90-45				X
PRNA10D	254	PRNA10D-90-45				X
PRNA20D	470	PRNA20D-90-45				X
PRN30DE	950	PRN30DE-90-45				X

How to select a PRN rotary actuator ?  
Refer page 28

#### Rotary Actuator mountings



Rotary Actuator	Flange mounting	Foot mounting
PRNA1S/D	PRN1-P	PRN1-L
PRNA3S /D	PRN3-P	PRN3-L
PRNA10S/ D	PRN10-P	PRN10-L
PRNA20S/D	PRN20-P	PRN20-L
PRN30SE/DE	PRN30-P	PRN30-L

The mountings are provided with set screws

#### Oscillation starting point and oscillation angle

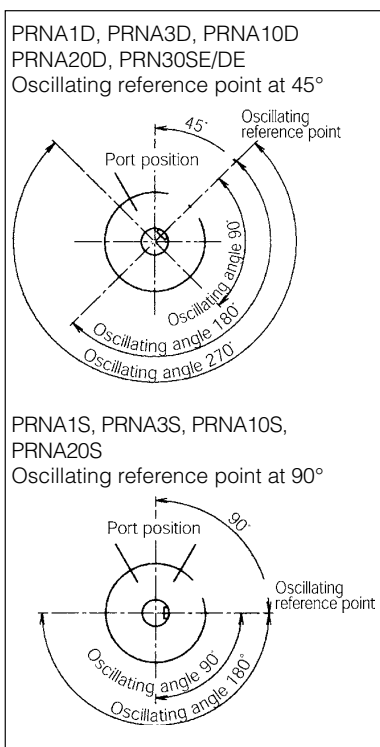

#### Switch units

Variable switch position, solid state NPN or PNP.  
Refer to page 13 for Technical information.



For Rotary Actuator	NPN	PNP
PRNA1S/D	FR-1PRNA	FP-1PRNA
PRNA3S/D	FR-3PRNA	FP-3PRNA
PRNA10S/D	FR-10PRN	FP-10PRN
PRNA20S/D	FR-20PRN	FP-20PRN
PRN30SE/DE	FR-30PRN	FP-30PRN

#### Maintenance kits

The maintenance kit consists in the vane shaft, shoe seal and shaft O'rings

For Rotary Actuator	Single vane		Double vane	
PRNA1S	PRNA1S-PS		PRNA1D	PRNA1D-PS
PRNA3S	PRNA3S-PS		PRNA3D	PRNA3D-PS
PRNA10S	PRNA10S-PS		PRNA10D	PRNA10D-PS
PRNA20S	PRNA20S-PS		PRNA20D	PRNA20D-PS
PRN30SE	PRN30S-PS		PRN30DE	PRN30D-PS

PDE2502TCUK

## Pneumatic Rotary Actuators - Series PRO - PRN

### PRN Miniature series - Technical data

#### Technical specification

PRN Rotary Actuators	Unit	PRNA1S	PRNA3S	PRNA10S	PRNA20S	PRN30SE
Vane		Single vane				
Air condition		Filtered (5µ) lubricated or non-lubricated				
Oscillating angle	°	90 / 180 / 270	90 / 180 / 270	90 / 180 / 270	90 / 180 / 270	90 / 180 / 270
Oscillating reference point	°	45, 90/45, 90/45	45, 90/45, 90/45	45, 90/45, 90/45	45, 90/45, 90/45	45
Port size		M5	M5	M5	M5	G1/8
Minimum operating pressure	bar	1,0	1,0	1,0	0,8	1,0
Operating pressure	bar	2 to 7	2 to 7	2 to 7	2 to 10	2 to 10
Operating temperature	°C	-5 to 80	-5 to 80	-5 to 80	-5 to 80	-5 to 60
Maximum operating frequency	cycles/mn	300 / 180 / 96	240 / 150 / 60	240 / 150 / 90	210 / 120 / 60	180 / 90 / 60
Internal volume	cm <sup>3</sup>	1,4 // 1,4 / 1,5	3,4 / 3,4 / 4	9,8 / 9,8 / 12	17 / 17 / 21	37 / 37 / 43
Allowable radial load	N	30	40	50	300	400
Allowable thrust load	N	3	4	4	25	30
Allowable energy	mJ	0,6	1,5	3	15	25
Weight	kg	0,036	0,070	0,140	0,250	0,47 / 0,47 / 0,46

PRN Rotary Actuators	Unit	PRNA1D	PRNA3D	PRNA10D	PRNA20D	PRN30DE
Vane		Double vane				
Air condition		Filtered (5µ) lubricated or non-lubricated				
Oscillating angle	°	90	90	90	90	90
Oscillating reference point	°	45	45	45	45	45
Port size		M5	M5	M5	M5	G1/8
Minimum operating pressure	bar	0,8	0,7	0,7	0,6	0,8
Operating pressure	bar	2 to 7	2 to 7	2 to 7	2 to 10	2 to 10
Operating temperature	°C	-5 to 80	-5 to 80	-5 to 80	-5 to 80	-5 to 60
Maximum operating frequency	cycles/mn	300	240	240	180	180
Internal volume	cm <sup>3</sup>	1,1	2,8	8,1	15,0	34,0
Allowable radial load	N	30	40	50	300	400
Allowable thrust load	N	3	4	4	25	30
Allowable energy	mJ	0,6	1,5	3	15	25
Weight	kg	0,037	0,072	0,140	0,260	0,480

Notes :

- Maximum operating frequency is given at 5 bar operating pressure (unloaded).
- Make sure to use the PRN rotary actuators within the allowable energy. Check if the required energy is lower than the allowable energy. If not, use end stoppers directly on the load.
- The PRN with keyways are provided with keys.

#### Materials specification

PRN	PRNA3, PRNA10, PRNA20	PRNA1, PRN30
Body	Aluminium alloy	Aluminium alloy
Solid vane shaft	Steel + resin + Hydr. Nitrile	Steel + resin + Nitrile
Shoe	Resin	Resin
Shoe seal	Hydrogenated Nitrile	Nitrile
O-ring	Hydrogenated Nitrile	Nitrile
Screws, claw, stoppers, locknut	Steel	Steel

#### Effective torque (N.cm)

Model n°	Operating pressure (bar)									
	2	3	4	5	6	7	8	9	10	
<b>Single vane</b>										
PRNA1S	4,9	7,6	10,1	12,9	15,6	18,5	-	-	-	-
PRNA3S	10	17	24	31	38	45	-	-	-	-
PRNA10S	35	56	75	98	120	139	-	-	-	-
PRNA20S	59	95	133	170	210	249	287	326	368	
PRN30SE	110	180	250	319	410	480	580	650	720	
<b>Double vane</b>										
PRNA1D	10,4	16,5	22,5	28,6	34,7	41,1	-	-	-	-
PRNA3D	25	39	54	71	86	101	-	-	-	-
PRNA10D	76	117	162	211	254	303	-	-	-	-
PRNA20D	140	222	306	388	470	553	633	717	807	
PRN30DE	270	440	600	770	950	1120	1299	1480	1660	

#### Switch units specification

Switch unit type	FR-	FP-
Application	Relay, PLC, IC circuit	PNP
Output method	NPN	PNP
Mounting	Switch position adjustable	
Operating voltage	DC5~30V	DC10~30V
Operating current	5 to 200 mA	5 to 200 mA
Indicating lamp	Lights up at ON	
Consumption	20mA at 24V	14mA at 24V 10mA at 12V 7mA at 12V 4mA at 5V
Max. leakage current	10 µA	
Internal voltage drop	1,5 V	
Average operating time	1 ms	
Shock resistance	490 m/s <sup>2</sup>	
Operating temperature	5 to 60 °C	
Protection	IP67	
Lead wire	1 m, 3 core, oil resistant	
Response range	23°±7°	
Hysteresis	Approx. 2°	

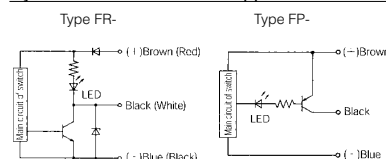

PDE2502TCUK

## Pneumatic Rotary Actuators - Series PRO - PRN

### PRN Miniature series - Technical data

#### Oscillating Time range

Model n°	Oscillation time range (s)		
	90°	180°	270°
PRNA1S	0,03 - 0,60	0,06 - 1,20	0,09 - 1,80
PRNA3S	0,04 - 0,80	0,08 - 1,60	0,12 - 2,40
PRNA10S	0,045 - 0,90	0,09 - 1,80	0,135 - 2,70
PRNA20S	0,05 - 1,00	0,10 - 2,00	0,15 - 3,00
PRN30SE	0,07 - 0,70	0,14 - 1,40	0,21 - 2,10
PRNA1D	0,03 - 0,60	0,06 - 1,20	0,09 - 1,80
PRNA3D	0,04 - 0,80	0,08 - 1,60	0,12 - 2,40
PRNA10D	0,045 - 0,90	0,09 - 1,80	0,135 - 2,70
PRNA20D	0,05 - 1,00	0,10 - 2,00	0,15 - 3,00
PRN30DE	0,07 - 0,70	0,14 - 1,40	0,21 - 2,10

**Note :** Operate the PRN rotary actuators within the range of duration mentioned in the above charts. Otherwise, the rotary actuator may move in stick-slip motion.

#### Switch mounting orientation

The 2 types of switches (-3L and -3R) included in the switch unit have to be oriented in accordance to the table herebelow :

Oscillating angle	Orientation of switches
30° and 180°	A
270°	B

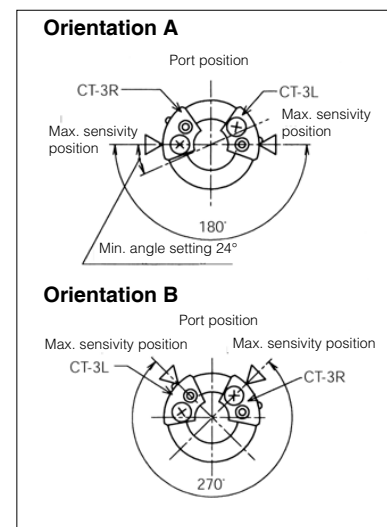

#### Setting the switch unit

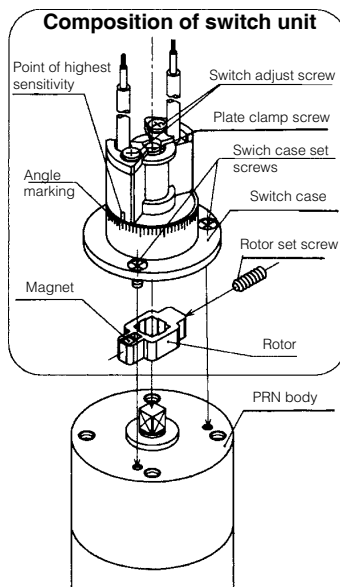

Mount the switch unit on the body using the set of screws. For clamping torque, refer to the table below :

Model	Clamping torque (N.cm)
PRNA1S /D	20 to 30
PRNA3S/D	20 to 30
PRNA10S/D	20 to 30
PRNA20S/D	20 to 30
PRN30SE/DE	20 to 30

#### Adjusting the switch position

Loosen the switch adjust screws, make the point, at which the highest sensitivity is obtained, match with the angle marking equivalent to the actuator setting, and retighten the switch adjust screws at a clamping torque of 40 to 50 N.cm. Since the angle markings are provided just for reference, make a final adjustment by checking if the LED is on.

#### Replacing the switch

To remove the switch, remove the switch adjust screws and plate clamp screw. To mount a switch, reverse the procedure for removal. Adjust the switch position after completion of mounting.

PDE2502TCUK

## Pneumatic Rotary Actuators - Series PRO - PRN

### PRN Miniature series - Dimensions (mm)

#### PRNA1S/D

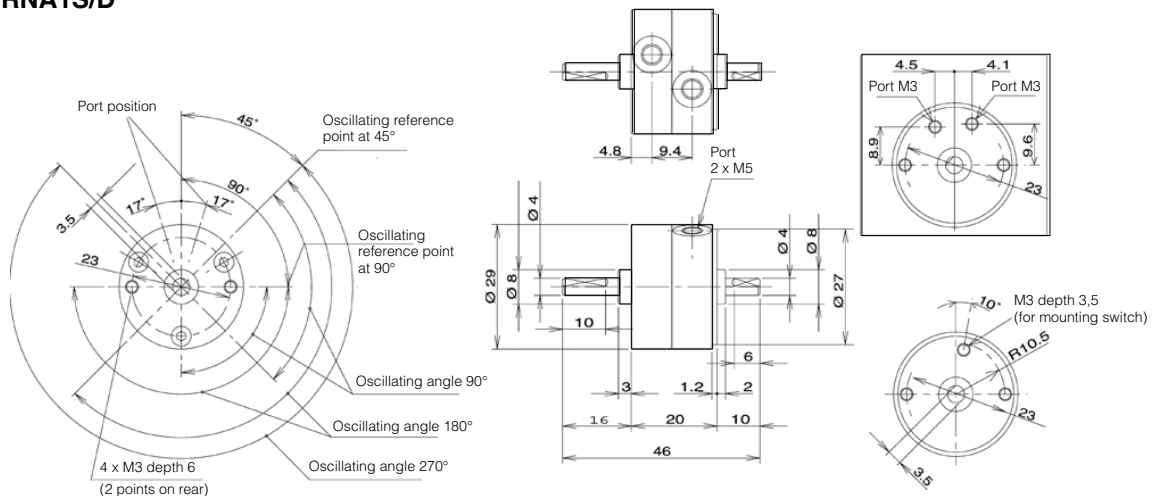

#### With foot plate mounting

**Note :**

A foot plate can be fitted turned by steps of 90° from the original position. Short shaft side : Example with 2 pcs.

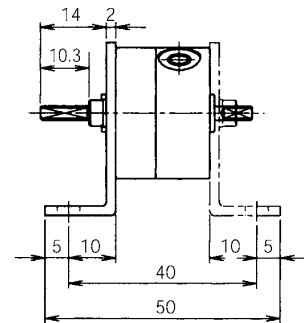
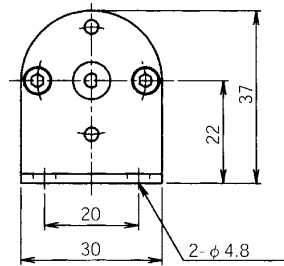

#### With flange plate mounting

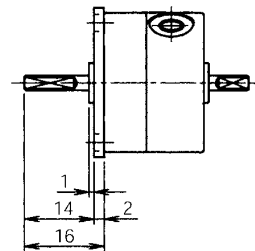
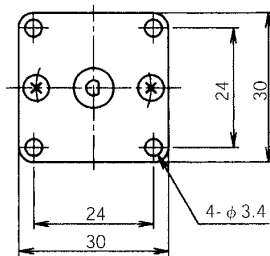

#### With switch unit (variable switch position)

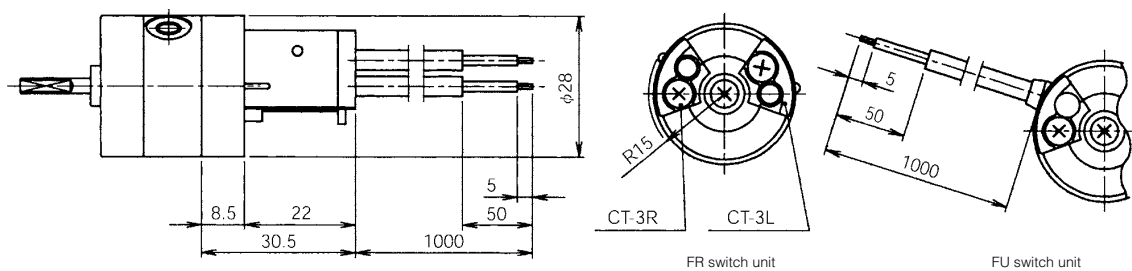

**Note :** For switch unit-mounting hardware combinations, refer to the required dimensions in each fig.



PDE2502TCUK

## Pneumatic Rotary Actuators - Series PRO - PRN

### PRN Miniature series - Dimensions (mm)

#### PRNA10S/D

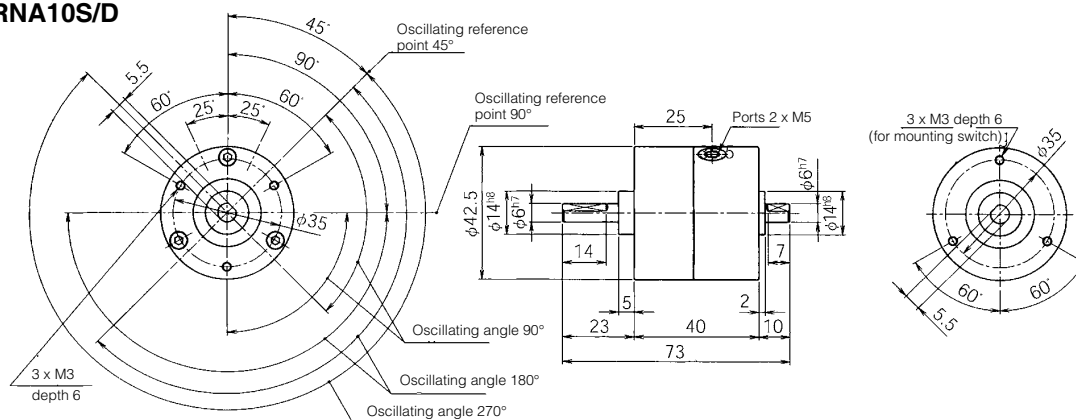

#### With foot plate mounting

**Note :**

A foot plate can be fitted turned by steps of 60° from the original position.  
Short shaft side : Example with 2 pcs.

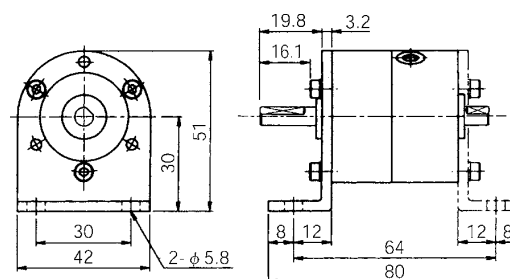

#### With flange plate mounting

**Note :**

A flange plate can be fitted turned by steps of 120° from the original position

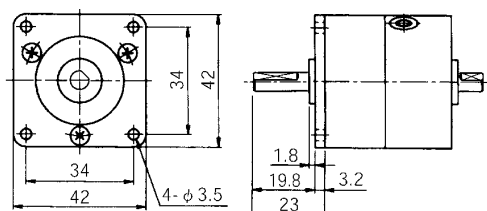

#### With switch unit (variable switch position)

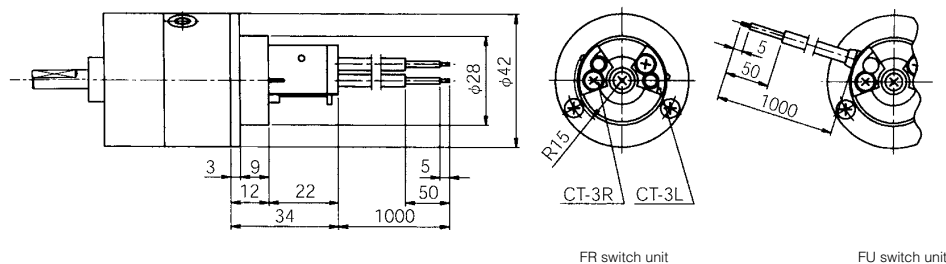

**Note :** For switch unit-mounting hardware combinations, refer to the required dimensions in each fig.



PDE2502TCUK

## Pneumatic Rotary Actuators - Series PRO - PRN

### PRN Miniature series - Dimensions (mm)

#### PRNA20S/D

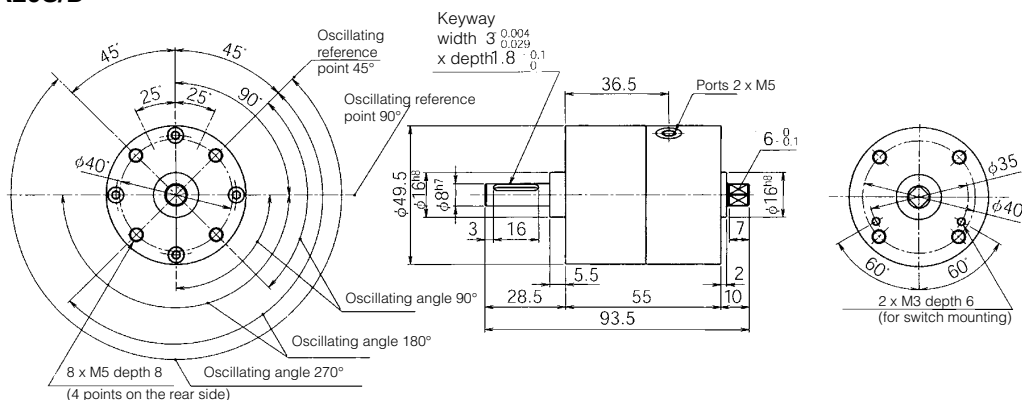

#### With flange plate mounting

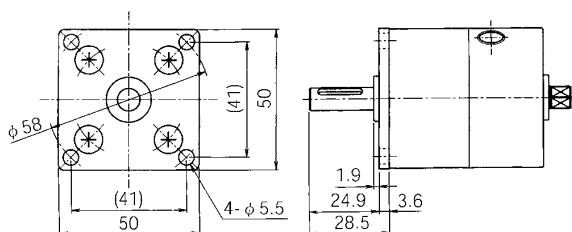

#### With foot plate mounting

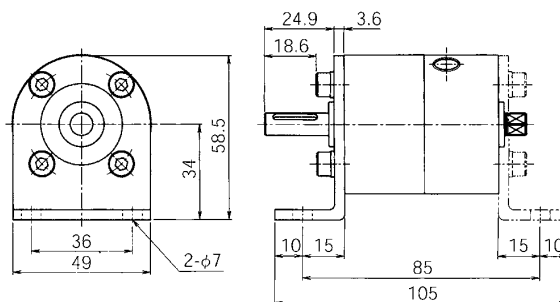

#### Note :

A foot plate can be fitted turned by steps of  $90^\circ$  from the original position.

Short shaft side : Example with 2 pcs.

#### With switch unit (variable switch position)

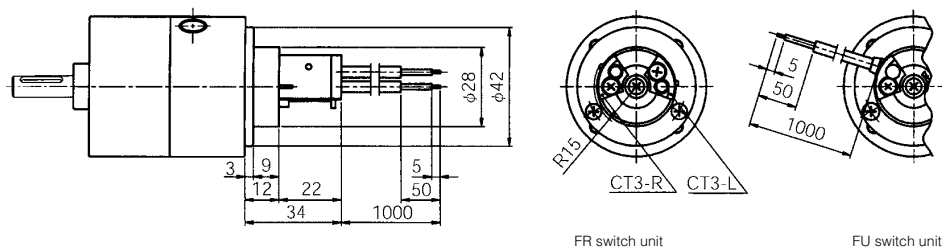

**Note :** For switch unit-mounting hardware combinations, refer to the required dimensions in each fig.

PDE2502TCUK

**Pneumatic Rotary Actuators - Series PRO - PRN**

**PRN Miniature series - Dimensions (mm)**

**PRN30SE/DE**

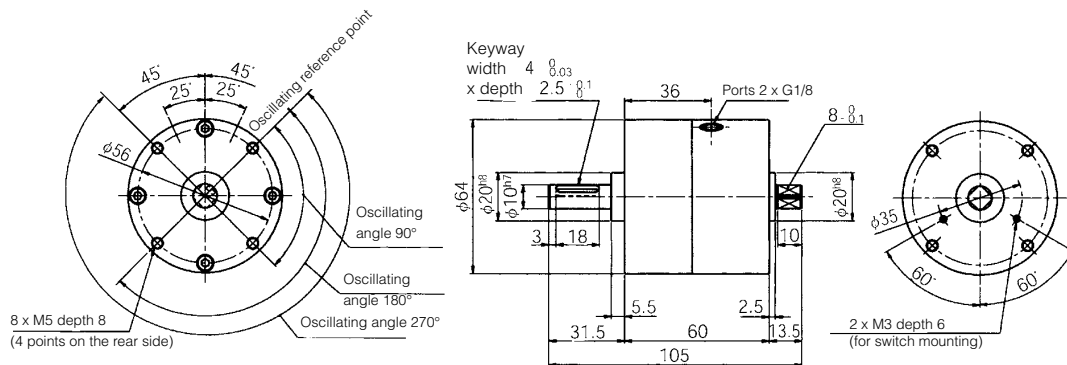

**With flange plate mounting**

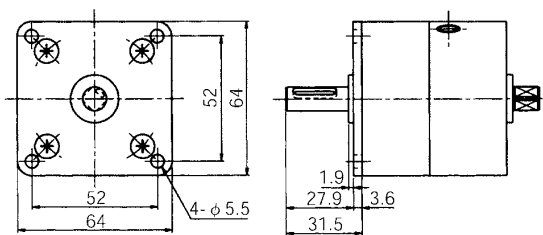

**With foot plate mounting**

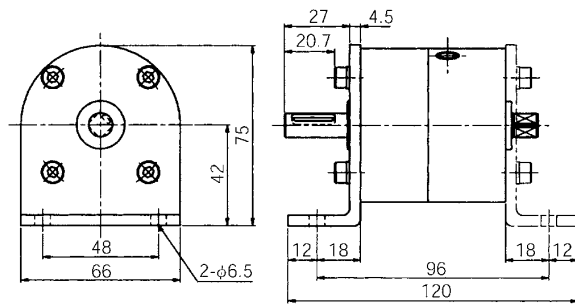

**Note :**

A foot plate can be fitted turned by steps of 90° from the original position.  
Short shaft side : Example with 2 pcs.

**With switch unit (variable switch position)**

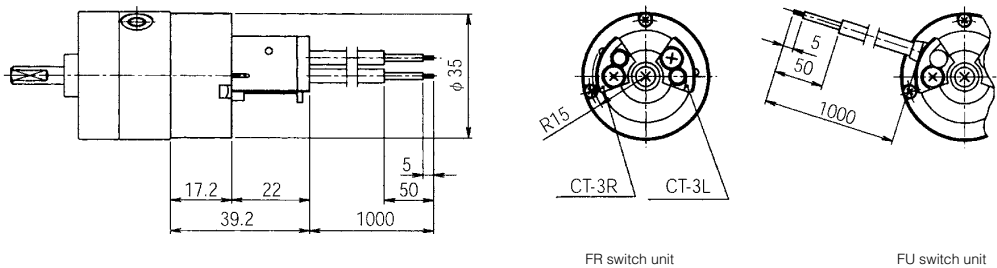

**Note :** For switch unit-mounting hardware combinations, refer to the required dimensions in each fig.



PDE2502TCUK

## Pneumatic Rotary Actuators - Series PRO - PRN

### PRN High Torque range - Fixed oscillating angle - Order Codes

#### Standard models



Model	Torque at 6 bar (N.cm)	Oscillating angle		
		90°	180°	270°
<b>Single vane (reference point 45°)</b>				
PRN50SE	590	PRN50SE-90-45	PRN50SE-180-45	PRN50SE-270-45
PRN150SE	1800	PRN150SE-90-45	PRN150SE-180-45	PRN150SE-270-45
PRN300SE	3450	PRN300SE-90-45	PRN300SE-180-45	PRN300SE-270-45
PRN800SE	12300	PRN800SE-90-45	PRN800SE-180-45	PRN800SE-270-45
<b>Double vane (reference point 45°)</b>				
PRN50DE	1280	PRN50DE-90-45		
PRN150DE	4150	PRN150DE-90-45		
PRN300DE	8300	PRN300DE-90-45		
PRN800DE	24700	PRN800DE-90-45		

How to select a PRN rotary actuator ?  
Refer page 28

#### Oscillation starting point and oscillation angle

**PRN50, PRN150, PRN300, PRN800**  
Oscillating reference point at 45°

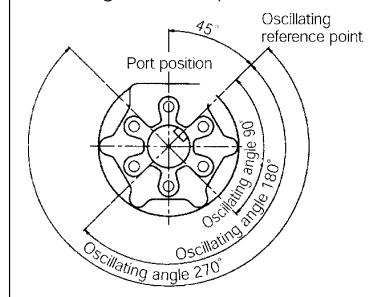

#### Rotary Actuator mountings

The mountings are provided with set screws

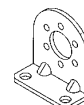
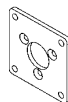

Rotary actuator	Flange mounting	Foot mounting
PRN50SE/DE	PRN50-P	PRN50-L
PRN150SE/DE	PRN150-P	PRN150-L
PRN300SE/DE	-	PRN300-L
PRN800SE/DE	-	PRN800-L

#### Switch unit



Variable switch position, reed type or solid state type (NPN or PNP).  
Refer to page 22.

#### Hydro-cushion



Hydraulic cushion to use when the inertial energy exceeds that allowable by the actuator.  
Refer to page 25.

#### Maintenance kits

The maintenance kit consists in the vane shaft, shoe seal and shaft O'rings

For Rotary Actuator		Double vane	
Single vane			
PRN50SE	PRN50S-PS	PRN50DE	PRN50D-PS
PRN150SE	PRN150S-PS	PRN150DE	PRN150D-PS
PRN300SE	PRN300S-PS	PRN300DE	PRN300D-PS
PRN800SE	PRN800S-PS	PRN800DE	PRN800D-PS

PDE2502TCUK

## Pneumatic Rotary Actuators - Series PRO - PRN

### PRN High Torque range - Technical data

#### Technical specification

PRN High Torque	Unit	PRN50SE	PRN150SE	PRN300SE
Vane		Single vane	Single vane	Single vane
Air condition		Filtered (5µ) lubricated or non-lubricated		
Oscillating angle	°	90 / 180 / 270	90 / 180 / 270	90 / 180 / 270
Oscillating reference point	°	45 / 45,40 / 45	45 / 45,40 / 45	45 / 45,40 / 45
Port size		G1/8	G1/4	G3/8
Minimum operating pressure	bar	1,0	0,8	0,8
Operating pressure	bar	2 to 10	2 to 10	2 to 10
Operating temperature	°C	5 to 60	5 to 60	5 to 60
Maximum operating frequency	cycles/mn	180 / 90 / 60	120 / 80 / 50	90 / 60 / 40
Internal volume	cm <sup>3</sup>	51 / 51 / 61	146 / 146 / 179	244 / 283 / 352
Allowable radial load	N	588	1 176	1 960
Allowable thrust load	N	44,1	88,2	147,0
Allowable energy	mJ	49,0	225,4	1 078,0
Weight	kg	0,82 / 0,79 / 0,73	2,00 / 1,90 / 1,70	3,70 / 3,70 / 3,70

PRN High Torque	Unit	PRN800SE	PRN50DE	PRN150DE	PRN300DE	PRN800DE
Vane		Single vane	Double vane	Double vane	Double vane	Double vane
Air condition		Filtered (5µ) lubricated or non-lubricated				
Oscillating angle	°	90 / 180 / 270	90	90	90	90
Oscillating reference point	°	45 / 45,40 / 45	45	45	45	45
Port size		G1/2	G1/8	G1/4	G3/8	G1/2
Minimum operating pressure	bar	0,5	0,8	0,6	0,6	0,5
Operating pressure	bar	2 to 10	2 to 10	2 to 10	2 to 10	2 to 10
Operating temperature	°C	5 to 60	5 to 60	5 to 60	5 to 60	5 to 60
Maximum operating frequency	cycles/mn	65 / 45 / 30	180	120	90	65
Internal volume	cm <sup>3</sup>	754 / 869 / 1 036	42	127	244	754
Allowable radial load	N	4 900	588	1 176	1 960	4 900
Allowable thrust load	N	490,0	44,1	88,2	147,0	490,0
Allowable energy	mJ	3 920,0	49,0	225,4	1 078,0	3 920,0
Weight	kg	12,70 / 12,20 / 11,20	0,82	2,00	4,30	12,70

#### Notes :

- Maximum operating frequency is given at 5 bar operating pressure (unloaded).
- Make sure to use the PRN rotary actuators within the allowable energy. Check if the required energy is lower than the allowable energy. If not, use a CRN hydro-check (refer to page 25) or end stoppers directly on the load.
- The PRN with keyways are provided with keys.

#### Materials specification

PRN	PRN50, PRN150	PRN300	PRN800
Body	Aluminium die casting alloy	Aluminium alloy	Aluminium alloy
Solid vane shaft	Structural steel alloy + Nitrile	Structural steel alloy + Nitrile	Structural steel alloy + Nitrile
Shoe	Zinc die casting alloy	Zinc die casting alloy	Zinc die casting alloy
Shoe seal	Nitrile	Nitrile	Nitrile
Damper	Uréthane	Uréthane	Uréthane
Bearing	-	-	Steel bearing
O-ring	Nitrile	Nitrile	Nitrile
Cover plate	-	-	Structural carbon steel
Screws, claw, stoppers, locknut	Steel	Steel	Steel

#### Effective torque (N.cm)

Model n°	Operating pressure (bar)									
	2	3	4	5	6	7	8	9	10	
Single vane PRN50SE	125	259	369	479	590	700	829	950	1060	
PRN150SE	550	850	1150	1500	1800	2100	2400	2730	3050	
PRN300SE	1050	1650	2250	2850	3450	4050	4600	5180	5750	
PRN800SE	3780	5910	8100	10200	12300	14400	16600	18600	20500	
Double vane PRN50DE	330	579	829	1040	1280	1510	1760	2010	2250	
PRN150DE	1250	1900	2700	3500	4150	4800	5500	6200	6900	
PRN300DE	2550	3900	5400	6800	8300	9700	11000	12400	13700	
PRN800DE	7740	12000	16100	20600	24700	28800	33200	37100	41100	

#### Oscillating time range (s)

	Oscillating angle		
	90°	180°	270°
PRN50	0.08-0.8	0.16-1.6	0.24-2.4
PRN150	0.12-1.2	0.24-2.4	0.36-3.6
PRN300	0.16-1.6	0.32-3.2	0.48-4.8
PRN800	0.22-2.2	0.44-4.4	0.66-6.6



PDE2502TCUK

## Pneumatic Rotary Actuators - Series PRO - PRN

### PRN High Torque range - Sensing

#### Order Codes



The switch unit consists in a 3-part mounting hardware combined with either a reed type or a solid state type sensors.

The 3 parts hardware are to be ordered separately :

- Base bracket
- Magnet arm
- Switch mounting (except for PRN800)

Switch units used with hydro-cushion, refer to page 25.

#### Standard mounting hardware for PRN

Rotary actuator	Base bracket	Magnet arm	Switch mounting
PRN50SE/DE	FM50-B	FM50-A	FM50-K
PRN150SE/DE	FM150-B	FM150-A	FM50-K
PRN300SE/DE	FM300-B	FM300-A	FM300-K
PRN800SE/DE	FM800-B	FM800-A	-

#### PRN50, PRN150, PRN300

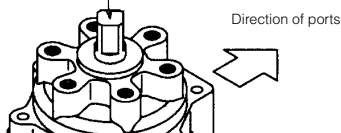
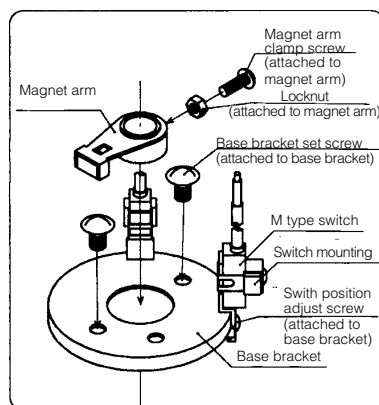

#### PRN800

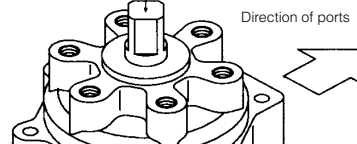
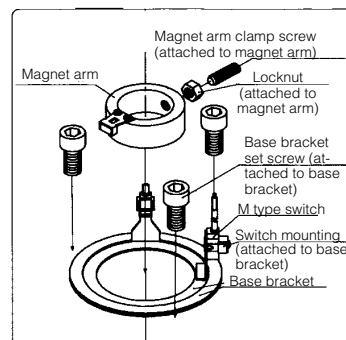

#### Technical data

	MA-1	MA-2L	MA-2H	MT-3	MTP-3
Application	Relay, PLC	Relay	Relay	Relay, PLC, IC circuit	Relay, PLC, IC circuit
Output method	Reed switch	Reed switch	Reed switch	NPN	PNP
Operating voltage (V)	AC100 - DC24	AC100/110	AC200/220	DC 5 to 30	DC 10 to 30
Operating current (mA)	5 to 45	5 to 150	5 to 150	5 to 200	5 to 200
Indicating lamp	Red LED up at ON 4,5VA-1W	Red LED up at ON 4,5VA	Red LED up at ON 4,5VA	Red LED up at ON 20 mA at 24V 10 mA at 12V	Yellow LED up at ON 20 mA at 24V 10 mA at 12V
Consumption		Surge suppressor	Surge suppressor	4 mA at 5V	
Internal voltage drop	2 V or less	-	-	1,5 V or less	1,5 V or less
Max. leak current	-	-	-	10 µA	10 µA
Average operating time	1 ms	1 ms	1 ms	1 ms	1 ms
Shock resistance	294 m/s <sup>2</sup>	294 m/s <sup>2</sup>	294 m/s <sup>2</sup>	490 m/s <sup>2</sup>	490 m/s <sup>2</sup>
Operating temperature	5 to 60 °C	5 to 60 °C	5 to 60 °C	5 to 60 °C	5 to 60 °C
Protection	IP67	IP67	IP67	IP67	IP67
Lead wire	1 m, 2-core	1 m, 2-core	1 m, 2-core	1 m, 3-core, oil resistant	1 m, 3-core, oil resistant

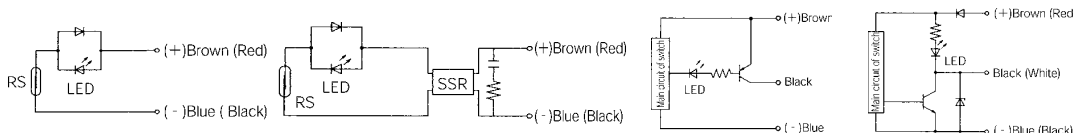

#### Dimensions (mm)

##### MA-1, MA-2

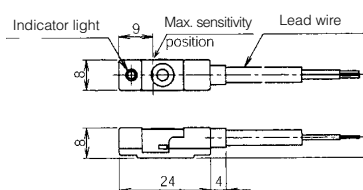

##### MT-3, MTP-3

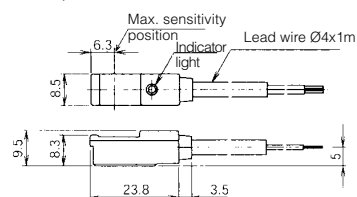

PDE2502TCUK

## Pneumatic Rotary Actuators - Series PRO - PRN

### PRN High Torque range - Dimensions (mm)

#### Standard model

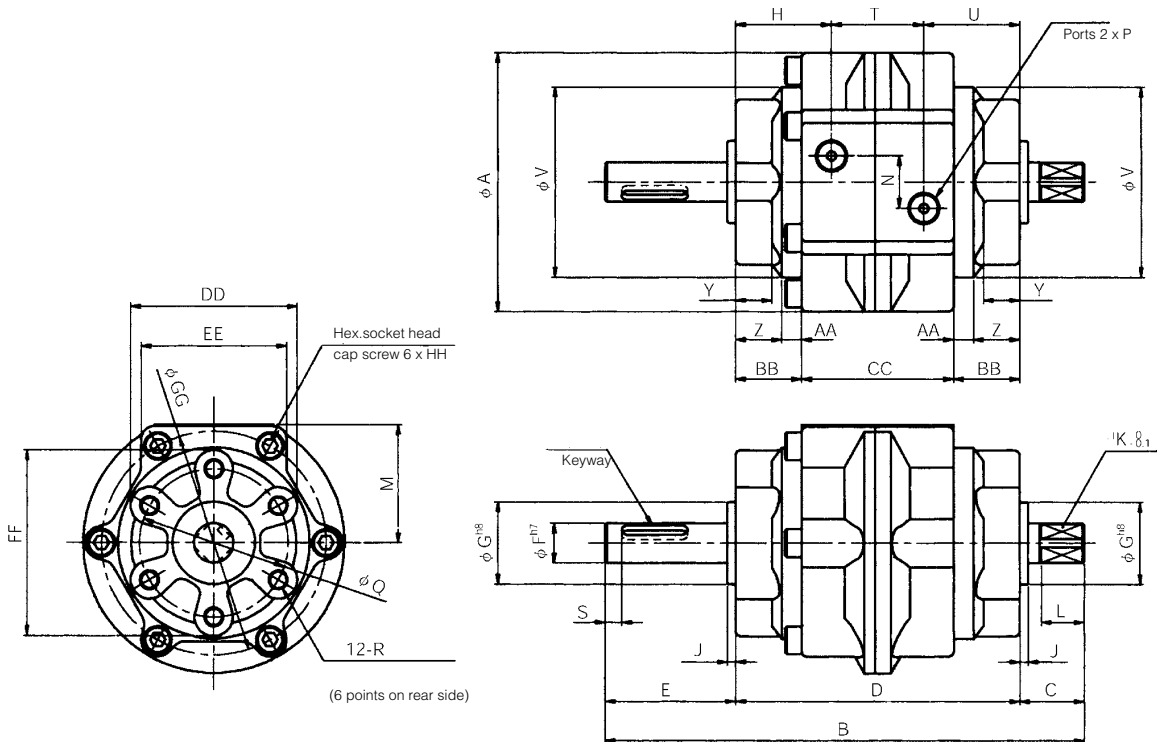

Type	A	B	C	D	E	F	G	H	J	K	L	M	N	P	Q	R	S	T
PRN50	79,0	145	19,5	86	39,5	12	25	29,0	2,5	10	13	36	16	G1/8	45	M6x1 depth 9	5	28
PRN150	110,0	180	23,5	103	53,5	17	30	34,5	3,0	13	16	51	24	G1/4	70	M8x1,25 depth 12	5	34
PRN300	141,5	220	30,0	125	65,0	25	45	41,5	3,5	19	22	66	32	G3/8	80	M10x1,5 depth 15	5	42
PRN800	196,0	285	44,5	171	69,5	40	70	53,5	4,5	32	35	90	44	G1/2	120	M12x1,75 depth 18	10	64

Type	U	V	Y	Z	AA	BB	CC	DD	EE	FF	GG	HH	Keyway WxDxL
PRN50	29,0	58,0	11,0	14,0	6,0	20,0	46	51,0	44,0	57,0	68,0	M5x30 L	4 <sup>0</sup> <sub>-0,030</sub> x 2,5 <sup>+0,1</sup> <sub>0</sub> x 20
PRN150	34,5	85,2	10,5	15,5	8,0	23,5	56	75,0	61,0	85,0	97,0	M6x35 L	5 <sup>0</sup> <sub>-0,030</sub> x 3 <sup>+0,1</sup> <sub>0</sub> x 36
PRN300	41,5	110,0	13,0	17,5	10,0	27,5	70	88,5	78,0	98,5	125,0	M8x45 L	7 <sup>0</sup> <sub>-0,036</sub> x 4 <sup>+0,1</sup> <sub>0</sub> x 40
PRN800	53,5	152,0	14,5	21,1	11,4	32,5	106	130,0	110,0	145,0	173,0	M12x70 L	12 <sup>0</sup> <sub>-0,043</sub> x 5 <sup>+0,2</sup> <sub>0</sub> x 40

PDE2502TCUK

## Pneumatic Rotary Actuators - Series PRO - PRN

### PRN High Torque range - Dimensions (mm)

#### With flange plate

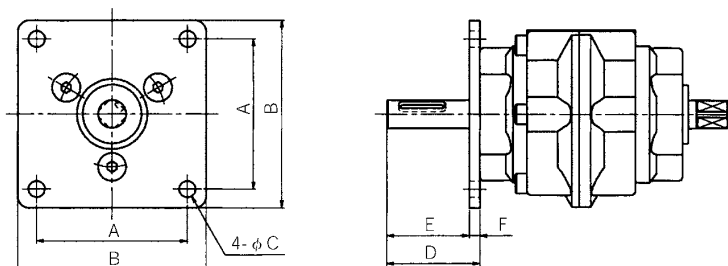

Type	A	B	C	D	E	F
PRN50	64	80	7	39,5	35,0	4,5
PRN150	88	110	9	53,5	47,5	6,0

Note : A flange plate can be fitted turned by steps of 60° from the original position

#### With foot plate

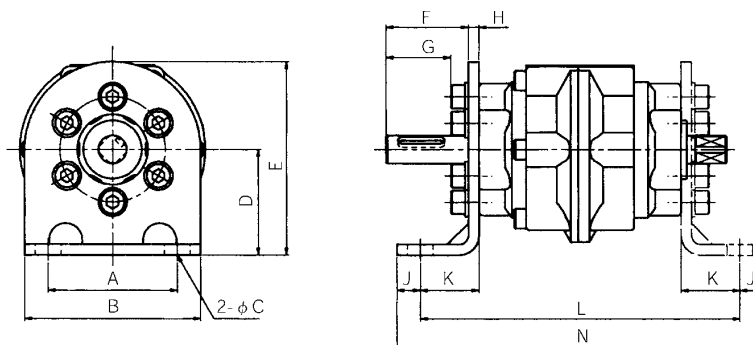

Type	A	B	C	D	E	F	G	H	J	K	L	N
PRN50	55	75	11	45	82,5	35,0	27,5	4,5	10	25	136	156
PRN150	80	110	13	65	115,0	43,5	33,5	10,0	12	28	159	183
PRN300	100	140	15	80	135,0	53,0	40,5	12,0	13	32	189	215
PRN800	140	200	15	110	200,0	54,5	39,5	15,0	15	35	241	271

**Note:**

A foot plate can be fitted turned by steps of 60° from the original position  
Short shaft side : Example with 2 pcs

#### With sensors

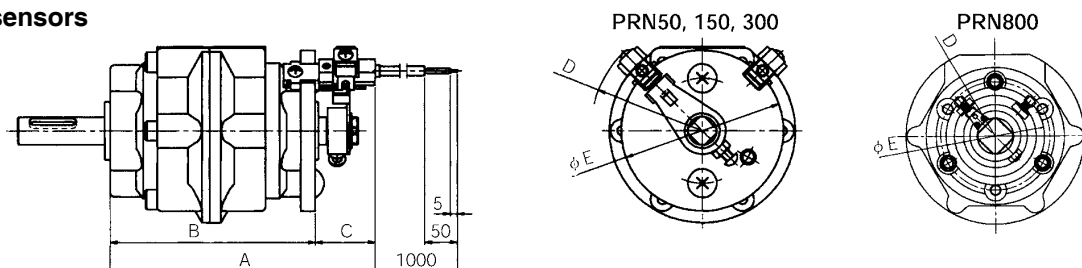

Type	A	B	C	D	E
PRN50	115,0	87,2	25,5	R47	69
PRN150	131,7	104,2	27,5	R61	97
PRN300	161,2	126,2	35,0	R69	113
PRN800	215,5	174,2	41,3	R60	108

PDE2502TCUK

## Pneumatic Rotary Actuators - Series PRO - PRN

### PRN High Torque range with Hydro-cushion

#### Order Codes

Hydraulic cushion for PRN high torque. Use these cushions when the inertial energy exceed the allowable energy of the PRN rotary actuator.



Rotary Actuator	Hydro-cushion	Claw for hydro-cushion - Oscillating angle		
		90°	180°	270°
<b>Single vane</b>				
PRN50SE	CRN50	CRN50-90-45-T	CRN50-180-45-T	CRN50-270-45-T
PRN150SE	CRN150	CRN150-90-45-T	CRN150-180-45-T	CRN150-270-45-T
PRN300SE	CRN300	CRN300-90-45-T	CRN300-180-45-T	CRN300-270-45-T
PRN800SE	CRN800	CRN800-90-45-T	CRN800-180-45-T	CRN800-270-45-T
<b>Double vane</b>				
PRN50DE	CRN50	CRN50-90-45-T		
PRN150DE	CRN150	CRN150-90-45-T		
PRN300DE	CRN300	CRN300-90-45-T		
PRN800DE	CRN800	CRN800-90-45-T		

#### Principle of operation

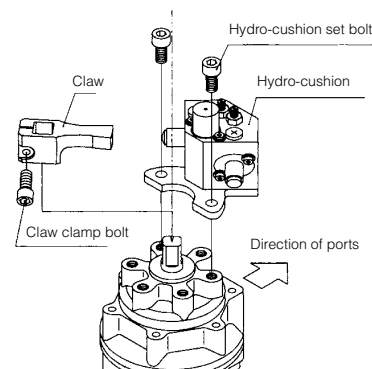
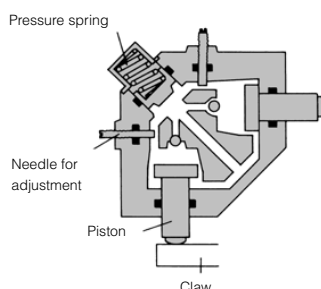

#### Specification

How to select a CRN hydro-cushion ? Refer page 29.

	Unit	CRN50	CRN150	CRN300	CRN800
<b>Applicable Rotary Actuator</b>		PRN50	PRN150	PRN300	PRN800
<b>Load range</b>	kg x cm <sup>2</sup>	981	2942	5884	19613
<b>Maximum absorption energy</b>	mJ	2942	9807	19613	58840
<b>Max. collision angular velocity</b>	°/s	850	750	650	550
<b>Max. energy capacity per mn</b>	mJ/mn	19613	70613	137293	353039
<b>Operating temperature</b>	°C	5 to 50	5 to 50	5 to 50	5 to 50
<b>Absorbing angle (one end)</b>	°	11	12	14	15
<b>Weight</b>	kg	0,240	0,420	0,780	1,620

#### Note :

Energy capability per mn = Absorbing energy x 2N

N: Operation frequency (cycle/mn)

When a rotary actuator is used with a hydro-cushion, keep an operating pressure of 3 bar or more.

#### Dimensions (mm)

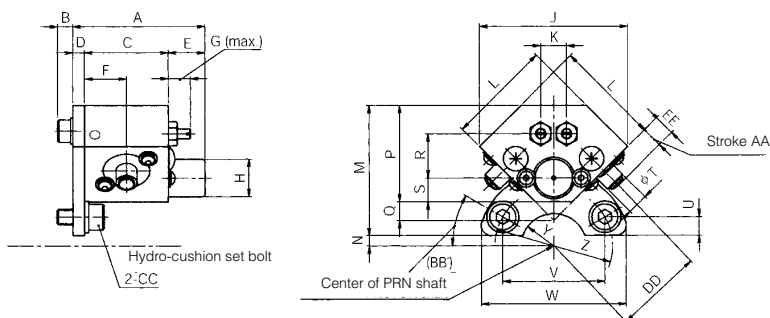

Model N°	A	B	C	D	E	F	G	H	J	K	L	M	N	P	Q	R	S	T	U	V	W	Y	Z	AA	BB	CC	DD	EE
CRN50	50,5	6,0	32	4,5	14	16	8,5	14,4	56,6	9,9	40	50	4	37	7,1	17,0	9,2	8	7,2	39,0	56	R12,5	R45	6,5	30	M6x12	34	8,0
CRN150	56,5	7,2	36	4,5	16	18	8,5	18,4	70,7	11,3	50	62	9,5	49	8,4	25,5	11,4	10	8,0	60,6	80	R15	R70	10,0	30	M8x16	46	12,0
CRN300	62,5	7,2	42	4,5	16	21	12,0	22,5	91,9	12,7	65	87	8	61	14,2	33,2	14,1	12	12,0	69,2	95	R22,5	R80	15,0	30	M10x20	62	18,0
CRN800	73,0	7,2	50	6,0	17	25	12,0	32,5	127,0	14,2	90	118	17	82	24,7	46,7	20,6	16	13,0	103,9	130	R35	R120	24,0	30	M12x20	90	27,5



PDE2502TCUK

## Pneumatic Rotary Actuators - Series PRO - PRN

### PRN High Torque range with Hydro-cushion - Sensors

#### Order Codes

The switch unit used with a CRN hydro-cushion consists in a 3-part mounting hardware combined with either a reed type or a solid state type sensors. The 3 parts hardware are to be ordered separately :

- Base bracket
- Magnet arm
- Switch mounting (except for PRN800)

#### Standard mounting hardware for PRN

Rotary actuator	Base Bracket	Magnet arm - Oscillating angle			Switch mounting
		90°	180°	270°	
PRN50SE	FM50-B	FC50-90-45-T	FC50-180-45-T	FC50-270-45-T	FC50-K
PRN150SE	FM150-B	FC150-90-45-T	FC150-180-45-T	FC150-270-45-T	FC50-K
PRN300SE	FM300-B	FC300-90-45-T	FC300-180-45-T	FC300-270-45-T	FC300-K
PRN800SE*	CRN800-FC	FC800-90-45-T	FC800-180-45-T	FC800-270-45-T	-
PRN50DE	FM50-B	FC50-90-45-T			FC50-K
PRN150DE	FM150-B	FC150-90-45-T			FC50-K
PRN300DE	FM300-B	FC300-90-45-T			FC300-K
PRN800DE*	CRN800-FC	FC800-90-45-T			-

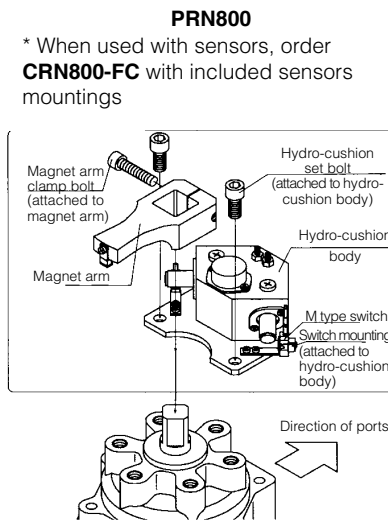
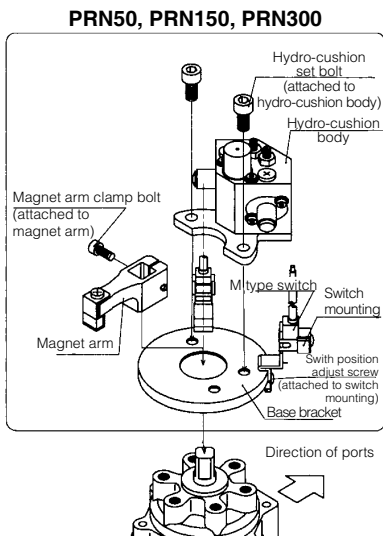

#### Technical data

	MA-1	MA-2L	MA-2H	MT-3	MTP-3
Application	Relay, PLC	Relay	Relay	Relay, PLC, IC circuit	Relay, PLC, IC circuit
Output method	Reed switch	Reed switch	Reed switch	NPN	NPN
Operating voltage (V)	AC100 - DC24	AC100/110	AC200/220	DC 5 to 30	DC 10 to 30
Operating current (mA)	5 to 45	5 to 150	5 to 150	5 to 200	5 to 200
Indicating lamp	Red LED up at ON	Red LED up at ON	Red LED up at ON	Red LED up at ON	Yellow LED up at ON
Consumption	4,5VA - 1W	4,5VA	4,5VA	20mA at 24V 10mA at 12V 4mA at 5V	20mA at 24V 10mA at 12V
Internal voltage drop	2 V or less	-	-	1,5 V or less	1,5 V or less
Max. leak current	-	-	-	10 µA	10 µA
Average operating time	1 ms	1 ms	1 ms	1 ms	1 ms
Shock resistance	294 m/s <sup>2</sup>	294 m/s <sup>2</sup>	294 m/s <sup>2</sup>	490 m/s <sup>2</sup>	490 m/s <sup>2</sup>
Operating temperature	5 to 60 °C	5 to 60 °C	5 to 60 °C	5 to 60 °C	5 to 60 °C
Protection	IP67	IP67	IP67	IP67	IP67
Lead wire	1 m, 2-core	1 m, 2-core	1 m, 2-core	1 m, 3-core, oil resistant	1 m, 3-core, oil resistant

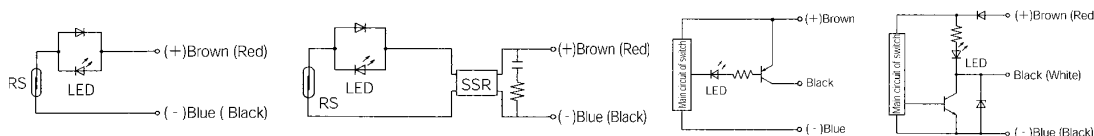

#### Dimensions (mm)

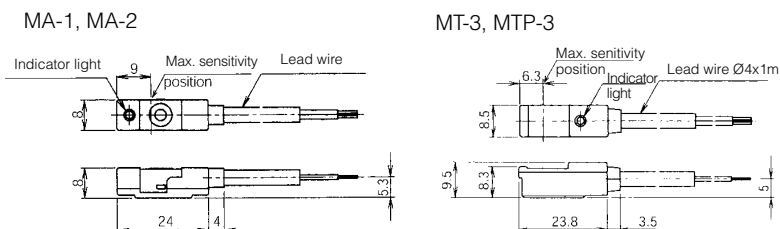

PDE2502TCUK

## Pneumatic Rotary Actuators - Series PRO - PRN

### PRN High Torque range with Hydro-cushion - Dimensions (mm)

#### PRN with hydro-cushion

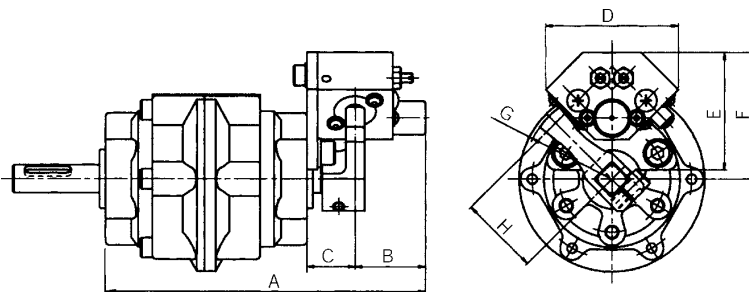

Type	A	B	C	D	E	F	G	H
PRN50	136,5	30	20,5	56	50	54,0	R38	34
PRN150	159,5	34	22,5	80	62	71,5	R51	46
PRN300	187,5	37	25,5	95	87	96,0	R68	62
PRN800	244,0	42	31,0	130	118	135,0	R78	90

#### PRN with hydro-cushion and switch unit

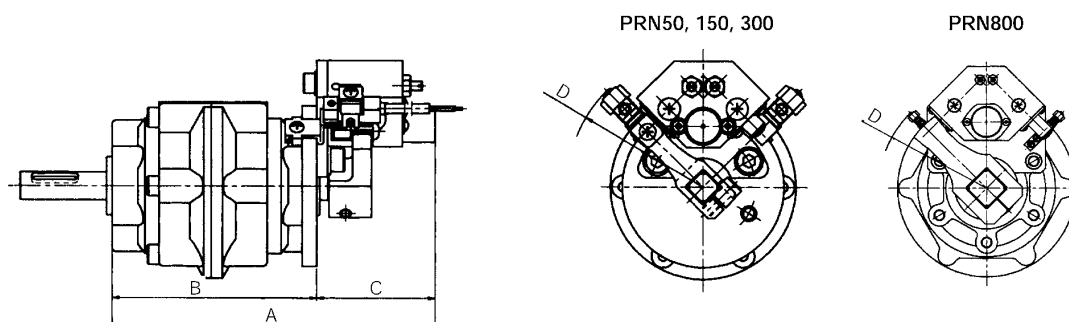

Type	A	B	C	D
PRN50	137,7	87,2	50,5	R58,2
PRN150	160,7	104,2	56,5	R72,2
PRN300	188,7	126,2	62,5	R88,2
PRN800	244,0	174,2	69,8	R118,5

#### Note :

Refer on page 23 for the dimensions of the standard PRN model

For switch unit mounting hardware or hydro-cushion combinations, refer to the required dimensions in each fig.

**Selecting a pneumatic Rotary Actuator**

**Step 1 : Selecting the size of the Rotary Actuator**

**When a simple static force is required (such as clamping force)**

**1. Determine the required force, arm length from actuator and operating pressure.**

Required force F(N)  
 Arm length from actuator l (m)  
 Operating pressure P(bar)

**2. Calculate the required torque**

$T_s = F \times l$  (N.m)  
 Required force F(N)  
 Arm length from actuator l (m)

**3. Compare the effective torque  $T_h$  of the actuator under the operating pressure with the required one  $T_s$ .**

Select a rotary actuator with :  $T_h > T_s$

Refer to the tables :

PRO : page 5  
 PRN miniature : page 13  
 PRN high torque : page 21

**When a the load is moving**

The required torque for moving a load is the total of resistance torque and acceleration torque.

The resistance torque is the sum of friction, gravity and external force and torques.

The acceleration torque is provided to accelerate the load to certain speed against inertia.

**1. Calculating the resistance torque  $T_r$**

a) Determine the resistance force, arm length from actuator and operating pressure.

Required force F(N)  
 Arm length from actuator l (m)  
 Operating pressure P(bar)

b) Calculate the resistance torque  $T_r$

$T_r = k \times F \times l$  (N.m)

k : margin factor k = 2 when there is no load variation  
 k = 5 when there is a load variation

Note : When there is a load variation, if  $k < 5$ , the angular velocity increases and thus smooth operation cannot be obtained

**2. Calculating the acceleration torque  $T_a$**

a) Determine the oscillating angle  $\theta$  and oscillating time t. Oscillating time is the time required for the vane to operate from starting point to the oscillation end.

Oscillating angle  $\theta$  (rad)  $90^\circ = 1.5708$  rad  
 $180^\circ = 3.1416$  rad  
 $270^\circ = 4.7124$  rad

**Oscilating time t (s)**

b) Calculate the moment of inertia

The moment of inertia is determined from the shape and the mass of the load.

Moment of inertia J (kg.m<sup>2</sup>)

c) Calculating angular acceleration

$\alpha = \theta / t^2$  (rad/s<sup>2</sup>)

$\theta$  (rad) : Oscillating angle

t (s) : Oscilating time

d) Calculating acceleration torque  $T_a$

$T_a = 5 \times J \times \alpha$  (N.m)

J : Moment of inertia of the load (kg.m<sup>2</sup>)

$\alpha$  : Angular acceleration (rad/s<sup>2</sup>)

**3. Calculating the required torque  $T_s$**

$T_s = T_r + T_a$  (N.m)

$T_r$  : Resistance torque (N.m)

$T_a$  : Acceleration torque (N.m)

**4. Compare the effective torque  $T_h$  of the actuator under the operating pressure with the required one  $T_s$ .**

Select a rotary actuator with :  $T_h > T_s$

Refer to :

PRO: p 5, PRN miniature: p 13, PRN high torque: p21

Calculating the resistance torque	Horizontal load	Vertical load
<b>Required</b>	<p><b>Load resistance exists</b></p> <p>External force</p> <p>Balanced load Unbalanced load</p>	<p><b>Load resistance exists</b></p> <p>External force</p> <p>Balanced load Unbalanced load Gravity</p>
<b>Not required</b>	<p><b>No load resistance exists</b></p> <p>Balanced load Unbalanced load</p> <p>Balanced load Unbalanced load</p>	<p><b>No load resistance exists</b></p> <p>Balanced load</p>

PDE2502TCUK

## Pneumatic Rotary Actuators - Series PRO - PRN

### Selecting a pneumatic Rotary Actuator (cont.)

## Step 2 : Checking the oscillating time

Check if the oscillating time is within the specification of each model. Refer to the pages :

PRO : page 6  
 PRN miniature : page 14  
 PRN high torque : page 21

## Step 3 : Checking the allowable energy

On the inertia matter, use the rotary actuator so that the inertial energy is lower than the allowable energy of the rotary actuator. Check as indicated here after :

### 1. Calculate the angular velocity $\omega$

$$\omega = \theta / t \text{ (rad/s)}$$

$\theta$  (rad) : Oscillating angle  
 $t$  (s) : Oscillating time

### 2. Calculate the inertial energy of the load E

$$E = 1/2 \times J \times \omega^2 \text{ (J)}$$

J : Moment of inertia of the load (kg.m<sup>2</sup>)  
 $\omega$  : Angular velocity (rad/s)

### 3. Check if the inertial energy E is within the allowable energy indicated in the specifications of each actuator.

PRO : page 5  
 PRN miniature : page 13  
 PRN high torque : page 21

#### Note :

If the inertial energy exceeds the allowable energy, the actuator may be damaged. Therefore, it is necessary to take the following measures :

- Select a larger size the allowable energy of which is higher than the energy required
- Slow down the oscillating time
- Use a hydro-cushion CRN (high torque PRN)
- Fit a cushion or other shock absorber directly on the load side.

## Selecting a hydro-cushion CRN

**1. Calculate the moment of inertia** by the shape and mass of the load, and make sure that it is within the allowable energy of the hydro-check

**2. Make sure that the collision angular velocity is less than the maximum allowable** (refer to the table page 25)

$$\omega_0 = 1,2 \times \omega \text{ (°/s)}$$

$\omega$  : Mean angular velocity (°/s)

**3. Calculate the collision energy from the load** and the collision angular velocity

$$E1 = 1/2 \times J \times \omega_0^2 \text{ (J)}$$

J : Moment of inertia (kg.m<sup>2</sup>)  
 $\omega_0$  : Collision angular velocity (rad/s)  $1^\circ = 0.0174 \text{ rad}$

**4. Find the energy generated from the torque of the actuator**

$$E2 = 1/2 \times T \times \theta \text{ (J)}$$

T : Torque of the rotary actuator (N.m)  
 $\theta$  : Absorbtion angle of the cushion (one side)  
 refer to page 25 (rad)

**5. Check that E1 + E2 is equal or less than the maximum absorbstion energy**

(table page 25)

**6. Find the energy per minute from the operation frequency**

$$Em = 2 \times N \times (E1+E2) \text{ (J/mn)}$$

N : operation frequency (mn)

**7. Make sure that Em is equal or less than the maximum energy capacity per mn** (table page 25)

PDE2502TCUK

## Pneumatic Rotary Actuators - Series PRO - PRN

### Reference data for selecting HI-ROTOR

#### Calculating the moment of inertia

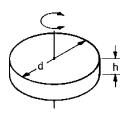
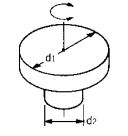
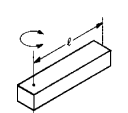
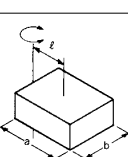
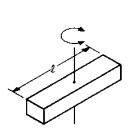
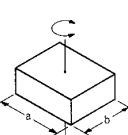
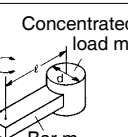
Shape	Sketch	Requirement	Inertia moment I (kgcm <sup>2</sup> )	Radius of gyration	Remarks
Disc		Diameter d (cm) Mass m (kg)	$I = m \cdot \frac{d^2}{8}$	$\frac{d^2}{8}$	
Stepped disc		Diameter d <sub>1</sub> (cm) Diameter d <sub>2</sub> (cm) Mass portion d <sub>1</sub> m <sub>1</sub> (kg) Mass portion d <sub>2</sub> m <sub>2</sub> (kg)	$I = m_1 \cdot \frac{d_1^2}{8} + m_2 \cdot \frac{d_2^2}{8}$	-	When portion d <sub>2</sub> is much smaller than portion d <sub>1</sub> , value of d <sub>2</sub> is negligible.
Bar (with rotating center at the end)		Bar length l (cm) Mass m (kg)	$I = m \cdot \frac{l^2}{3}$	$\frac{l^2}{3}$	If the ratio of the bar width : length is over 0.3, use formula for rectangle.
Rectangular parallelepiped		Side length a (cm) Side length b (cm) Distance between the center of gravity and rotation I (cm) Mass m (kg)	$I = m (l^2 + \frac{a^2+b^2}{12})$	$l^2 + \frac{a^2+b^2}{12}$	
Bar (with rotating center at the center)		Bar length l (cm) Mass m (kg)	$I = m \cdot \frac{l^2}{12}$	$\frac{l^2}{12}$	If the ratio of the bar width : length is over 0.3, use formula for rectangle.
Rectangular parallelepiped		Side length a (cm) Side length b (cm) Mass m (kg)	$I = m \cdot \frac{a^2+b^2}{12}$	$\frac{a^2+b^2}{12}$	
Concentrated load		Shape of concentrated load Disc Diameter of disc d (cm) Arm length l (cm) Mass of concentrated load m <sub>1</sub> (kg) Mass of arm m <sub>2</sub> (kg)	$I = m_1 \cdot l^2 + m_1 \cdot K_1^2 + m_2 \cdot \frac{l^2}{12}$ Case of disc $K_1^2 = \frac{d^2}{8}$	$K_1^2$ : Select from above this column	If m <sub>2</sub> is much smaller than m <sub>1</sub> , assume m <sub>2</sub> to be 0 for calculation.

How to convert the inertia of load applied through gears "I<sub>L</sub>" for HI-ROTOR's shaft

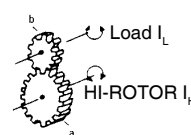
Gear		Gear HI-ROTOR side a Load side b Inertia moment of load I <sub>L</sub> (kgcm <sup>2</sup> )	Inertia moment of load HI-ROTOR's shaft $I_H = (\frac{a}{b})^2 I_L$	-	When a large gear is required, it is necessary to take inertia moment of gear into consideration.
------	---	--	--	---	---

**Rotary Actuators - Common instructions**

**Installation**

 **Warning**

The Rotary Actuators should be installed according to the rules of safe use of compressed air and the general rules relating to systems, especially the European Machinery Directive.

**Do not apply excessive stress to the shaft.**

**1. Heavy thrust load should be avoided**

When the thrust load is higher than the allowable thrust load prescribed in the specifications, please use a bearing as shown in fig. 1.

**2. Heavy radial loads should be avoided**

When the radial load is higher than the allowable radial load prescribed in the specifications, please use flexible coupling as shown in fig. 2.

**3. Check the allowable energy**

If the impact energy is higher than the allowable energy, use a CRN hydro-cushion or external stoppers operating directly on the load.

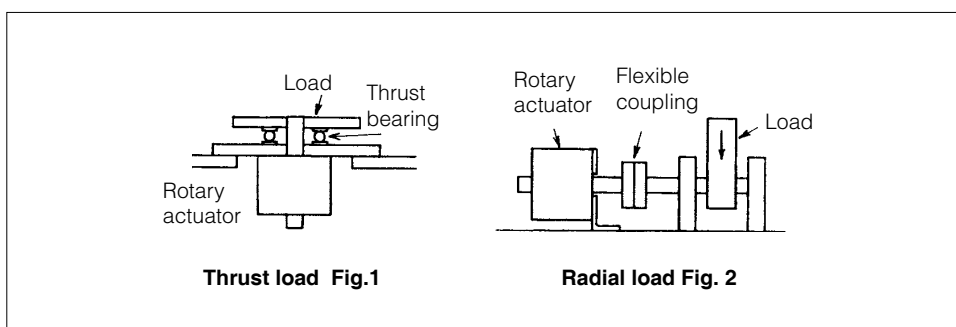

**Do not hit the shaft when the body is fixed or the body when the shaft is fixed.**

When mounting a load or couplings on the shaft, set the rotary actuator in such a way that the body does not receive any force, as shown in the Fig. 3.

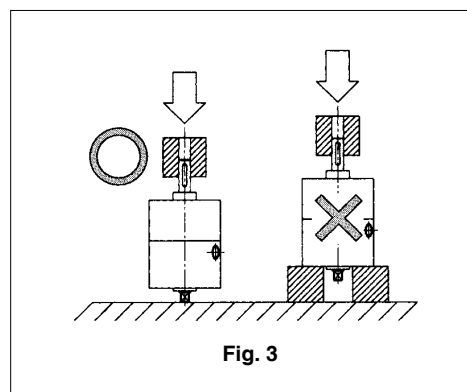

**Lubrication**

 **Caution**

**The rotary actuators listed in this catalogue operate non-lubricated.**

This product is design to be used with non-lubricated air, however, they may be used with or without lubricated air. When used with lubricated air, this must be continued as the original lubricant may have run off, which could result in operation failure.

When using a lubricant, Class 1 turbine oil ISO VG32 (containing additive) is recommended. Do not use spindle oil and machine oil, that may damage the seals.

## Parker Worldwide

### Europe, Middle East, Africa

**AE – United Arab Emirates,**  
Dubai

Tel: +971 4 8127100  
parker.me@parker.com

**AT – Austria,** Wiener Neustadt

Tel: +43 (0)2622 23501-0  
parker.austria@parker.com

**AT – Eastern Europe,** Wiener  
Neustadt

Tel: +43 (0)2622 23501 900  
parker.easteurope@parker.com

**AZ – Azerbaijan,** Baku

Tel: +994 50 2233 458  
parker.azerbaijan@parker.com

**BE/LU – Belgium,** Nivelles

Tel: +32 (0)67 280 900  
parker.belgium@parker.com

**BY – Belarus,** Minsk

Tel: +375 17 209 9399  
parker.belarus@parker.com

**CH – Switzerland,** Etoy

Tel: +41 (0)21 821 87 00  
parker.switzerland@parker.com

**CZ – Czech Republic,** Klecany

Tel: +420 284 083 111  
parker.czechrepublic@parker.com

**DE – Germany,** Kaarst

Tel: +49 (0)2131 4016 0  
parker.germany@parker.com

**DK – Denmark,** Ballerup

Tel: +45 43 56 04 00  
parker.denmark@parker.com

**ES – Spain,** Madrid

Tel: +34 902 330 001  
parker.spain@parker.com

**FI – Finland,** Vantaa

Tel: +358 (0)20 753 2500  
parker.finland@parker.com

**FR – France,** Contamine s/Arve

Tel: +33 (0)4 50 25 80 25  
parker.france@parker.com

**GR – Greece,** Athens

Tel: +30 210 933 6450  
parker.greece@parker.com

**HU – Hungary,** Budapest

Tel: +36 1 220 4155  
parker.hungary@parker.com

**IE – Ireland,** Dublin

Tel: +353 (0)1 466 6370  
parker.ireland@parker.com

**IT – Italy,** Corsico (MI)

Tel: +39 02 45 19 21  
parker.italy@parker.com

**KZ – Kazakhstan,** Almaty

Tel: +7 7272 505 800  
parker.easteurope@parker.com

**NL – The Netherlands,** Oldenzaal

Tel: +31 (0)541 585 000  
parker.nl@parker.com

**NO – Norway,** Asker

Tel: +47 66 75 34 00  
parker.norway@parker.com

**PL – Poland,** Warsaw

Tel: +48 (0)22 573 24 00  
parker.poland@parker.com

**PT – Portugal,** Leca da Palmeira

Tel: +351 22 999 7360  
parker.portugal@parker.com

**RO – Romania,** Bucharest

Tel: +40 21 252 1382  
parker.romania@parker.com

**RU – Russia,** Moscow

Tel: +7 495 645-2156  
parker.russia@parker.com

**SE – Sweden,** Spånga

Tel: +46 (0)8 59 79 50 00  
parker.sweden@parker.com

**SK – Slovakia,** Banská Bystrica

Tel: +421 484 162 252  
parker.slovakia@parker.com

**SL – Slovenia,** Novo Mesto

Tel: +386 7 337 6650  
parker.slovenia@parker.com

**TR – Turkey,** Istanbul

Tel: +90 216 4997081  
parker.turkey@parker.com

**UA – Ukraine,** Kiev

Tel: +380 44 494 2731  
parker.ukraine@parker.com

**UK – United Kingdom,** Warwick

Tel: +44 (0)1926 317 878  
parker.uk@parker.com

**ZA – South Africa,** Kempton Park

Tel: +27 (0)11 961 0700  
parker.southafrica@parker.com

### North America

**CA – Canada,** Milton, Ontario

Tel: +1 905 693 3000

**US – USA,** Cleveland

Tel: +1 216 896 3000

### Asia Pacific

**AU – Australia,** Castle Hill

Tel: +61 (0)2-9634 7777

**CN – China,** Shanghai

Tel: +86 21 2899 5000

**HK – Hong Kong**

Tel: +852 2428 8008

**IN – India,** Mumbai

Tel: +91 22 6513 7081-85

**JP – Japan,** Tokyo

Tel: +81 (0)3 6408 3901

**KR – South Korea,** Seoul

Tel: +82 2 559 0400

**MY – Malaysia,** Shah Alam

Tel: +60 3 7849 0800

**NZ – New Zealand,** Mt Wellington

Tel: +64 9 574 1744

**SG – Singapore**

Tel: +65 6887 6300

**TH – Thailand,** Bangkok

Tel: +662 186 7000-99

**TW – Taiwan,** Taipei

Tel: +886 2 2298 8987

### South America

**AR – Argentina,** Buenos Aires

Tel: +54 3327 44 4129

**BR – Brazil,** Sao Jose dos Campos

Tel: +55 800 727 5374

**CL – Chile,** Santiago

Tel: +56 2 623 1216

**MX – Mexico,** Apodaca

Tel: +52 81 8156 6000

European Product Information Centre

Free phone: 00 800 27 27 5374

(from AT, BE, CH, CZ, DE, DK, EE, ES, FI,  
FR, IE, IL, IS, IT, LU, MT, NL, NO, PL, PT, RU,  
SE, SK, UK, ZA)



### Parker Hannifin Ltd.

Tachbrook Park Drive  
Tachbrook Park,  
Warwick, CV34 6TU  
United Kingdom  
Tel.: +44 (0) 1926 317 878  
Fax: +44 (0) 1926 317 855  
parker.uk@parker.com  
www.parker.com