



## 2A Pneumatic Cylinders

Steel-bodied tie rod cylinders for working pressures up to 18 bar

aerospace  
climate control  
electromechanical  
filtration  
fluid & gas handling  
hydraulics  
pneumatics  
process control  
sealing & shielding



ENGINEERING YOUR SUCCESS.

**Mounting Styles**

**2A Cylinder Mounting Styles**

The standard range of Parker 2A cylinders comprises 15 mounting styles, to suit the majority of applications. General guidance for the selection of the cylinders is given below, with dimensional information about each mounting style shown on pages 8 to 20 for 25.4mm to 152.4mm (1" to 6") bore sizes, and pages 22 to 30 for 203.2mm to 355.6mm (8" to 14") bore sizes.

Application-specific mounting information is shown on pages 36 and 37.

Where a non-standard mounting style is required to satisfy a particular application, our design engineers will be happy to assist. Please contact the factory for details.

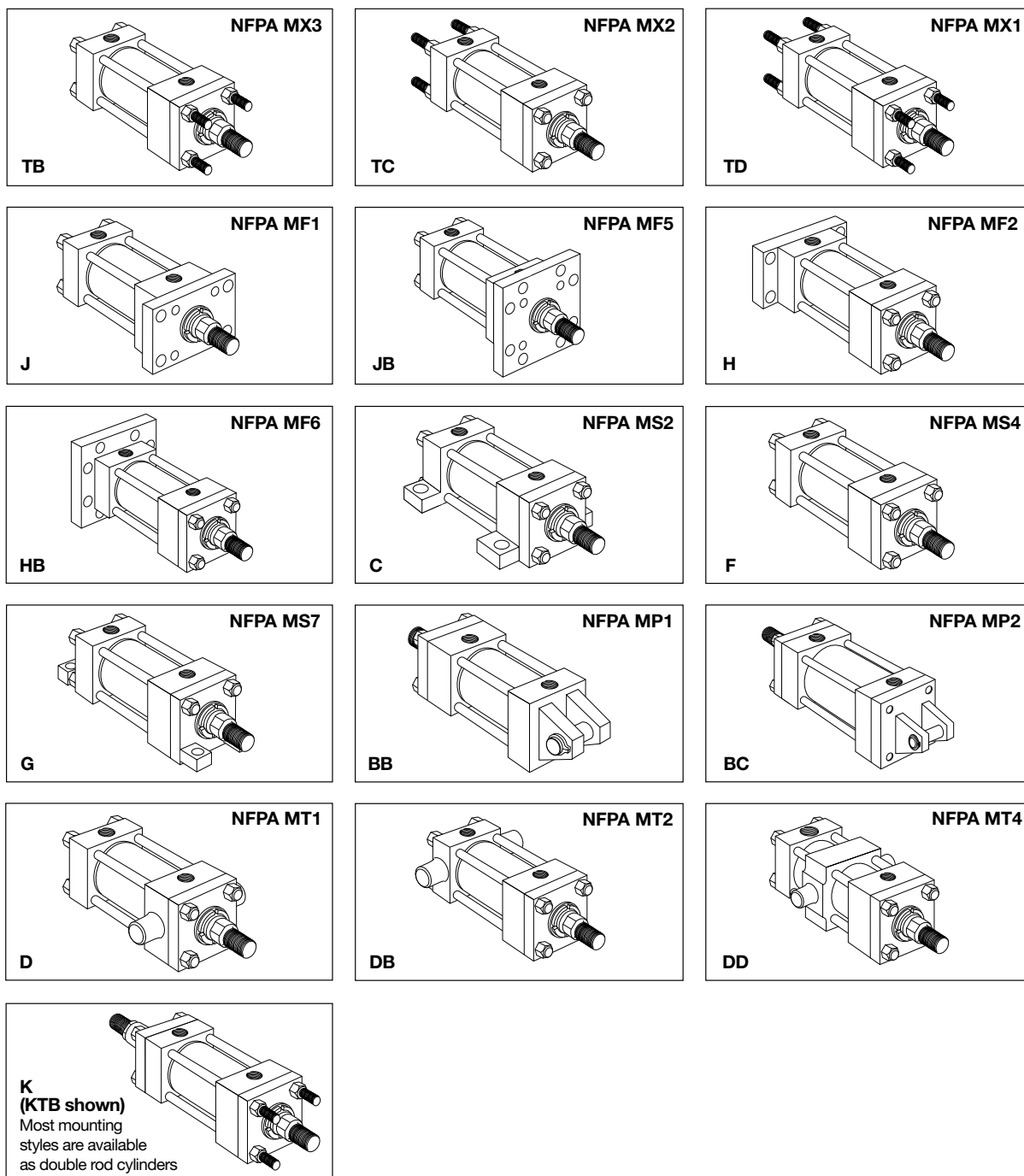

**Introduction**

**2A Series**

**Introduction**

The heavy duty series 2A pneumatic cylinders described in this catalogue are of all-steel construction and are based on the Parker series 3L hydraulic range – see catalogue HY07-1130. They are exceptionally robust and are ideally suited for applications in steel mills, foundries, aluminium smelting plants or other arduous environments where normal light duty aluminium cylinders are not sufficiently durable. In addition to the standard cylinders featured in this catalogue, 2A cylinders can be designed to suit customer requirements. Our engineers will be pleased to advise on unique designs to suit specific applications.

**inPHorm**

European Cylinder inPHorm is Parker Hannifin's product selection program that helps to select the correct part for an application. The program prompts for the details of the application, makes the necessary design calculations, and selects a suitable product. inPHorm can also generate CAD drawings of the selected part, which can be viewed in other software applications, and customised and imported into other CAD packages. Please contact your local sales office (see rear cover) for further information.

**Contents**

	<b>Page</b>
Design Features and Benefits	4
Standard Specifications	5
Seal Groups	5
Cylinder Selection Check List	6
Mounting Styles	7
Dimensions – 25.4mm to 152.4mm (1" to 6") bore sizes	8
Piston Rod End Data –	
25.4mm to 152.4mm (1" to 6") bore sizes	20
Double Rod Cylinders	21
Dimensions – 203.2mm to 355.6mm (8" to 14") bore sizes	22
Piston Rod End Data –	
203.2mm to 355.6mm (8" to 14") bore sizes	30
Accessories	31
Non-Lubricated Air Cylinders (2AN Series)	34
Mounting Information	36
Pressure Limitations	37
Push and Pull Forces	38
Piston Rod Sizes & Stop Tubes	39
Stroke Factors & Long Stroke Cylinders	40
Cushioning	41
Ports, Locations and Piston Speeds	42
Optional Features	43
Replacement Parts and Service	44
Repairs	45
Storage Information & Cylinder Mass Data	46
Warranty	46
How to Order Cylinders	47

**Parker Offers the Widest Range of Industrial Cylinders**

**High Productivity – Low Cost of Ownership**

Parker Hannifin's Cylinder Division is the world's largest supplier of hydraulic cylinders for industrial applications.

Parker manufactures a vast range of standard and special tie rod, roundline and 'mill' type cylinders to suit all types of industrial cylinder applications. Our cylinders are available to ISO, DIN, NFPA, ANSI and JIC standards, with other certifications available on request. All Parker hydraulic and

heavy duty pneumatic cylinders are designed to deliver long, efficient service with low maintenance requirements, guaranteeing high productivity year after year.

**About Parker Hannifin**

Parker Hannifin is the global leader in motion and control technologies, partnering with its customers to increase their productivity and profitability. The company employs more than 57,000 people in 43 countries around the world, providing customers with technical excellence and first class customer service.

Visit us at [www.parker.com/eu](http://www.parker.com/eu)

**Warning**

FAILURE OR IMPROPER SELECTION OR IMPROPER USE OF THE PRODUCTS AND/OR SYSTEMS DESCRIBED HEREIN OR RELATED ITEMS CAN CAUSE DEATH, PERSONAL INJURY AND PROPERTY DAMAGE.

This document and other information from Parker Hannifin Corporation, its subsidiaries, sales offices and authorized distributors provide product or system options for further investigation by users having technical expertise. Before you select or use any product or system it is important that you analyse all aspects of your application and review the information concerning the product or system in the current product catalogue. Due to the variety of operating conditions and applications for these products or systems, the user, through his own analysis and testing, is solely responsible for making the final selection of the products and systems and assuring that all performance and safety requirements of the application are met.

The products described herein, including without limitation, product features, specifications, designs, availability and pricing, are subject to change by Parker Hannifin Corporation and its subsidiaries at any time without notice.

**Offer of Sale**

Please contact you local Parker representative for a detailed offer of sale.



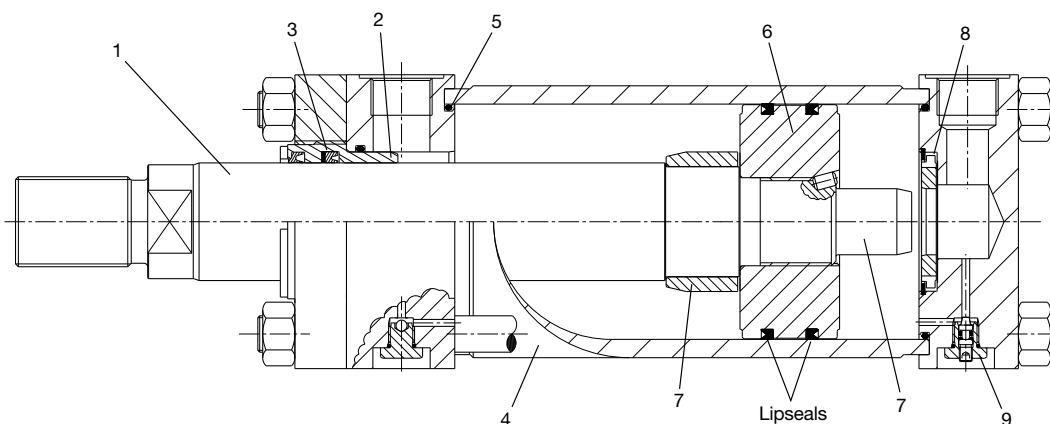

### 1 Piston Rod

Gland seal life is maximised by manufacturing piston rods from precision ground, high tensile carbon alloy steel, hard chrome plated and polished to 0.2µm max. Piston rods are induction case hardened to Rockwell C54 minimum before chrome plating, resulting in a dent-resistant surface.

### 2 Rod Gland

The rod gland, complete with rod seals, can easily be removed without dismantling the cylinder, so servicing is quicker – and therefore more economical.

### 3 Rod Seals

The serrated lipseal has a series of sealing edges which take over successively as pressure increases, providing efficient sealing under all operating conditions. On the return stroke the serrations act as a check valve.

The double lip wiperseal acts as a secondary seal, cleaning the rod on the return stroke. Its outer lip prevents the ingress of dirt into the cylinder, extending the life of gland and seals.

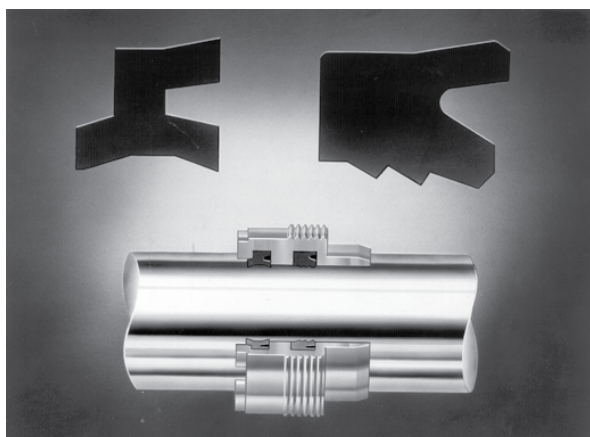

### Non-Lubricated Rod Seals

For non-lubricated air cylinders, rod seals with special rounded sealing lips are supplied as standard. Specify series 2AN (see pages 34-35).

### 4 Cylinder Body

The surface of the cylinder bore is finished to minimise internal friction and prolong seal life. The bore of the cylinder is hard chrome-plated to prevent corrosion and extend the life of the cylinder.

### 5 Cylinder Body Seals

To ensure that the cylinder body remains leak free, even under pressure shock conditions, Parker fits pressure-energised body seals.

### 6 Piston

Lipseal pistons are fitted as standard to 2A cylinders. All pistons are of one-piece type, and feature wide bearing surfaces to resist side loading. Long thread engagement secures the piston to the piston rod and, for additional safety, the piston is secured by thread-locking adhesive and a locking pin.

### 7 Cushioning

End of stroke deceleration is available by using straight cushions at the head and cap – see page 41 for details. The head and cap end cushions are self-centring. The polished cap end spear is an integral part of the piston rod.

### 8 Floating Cushion Bushes & Sleeves

Cushioning is provided by the use of a floating cushion sleeve at the head end of the cylinder, and a floating cushion bush at the cap end. The use of a check valve in the head and lifting of the bronze cushion bush in the cap, provides minimum flow restriction at the start of the return stroke. This allows full pressure to be applied over the whole area of the piston, to provide full power and fast cycle times.

### 9 Cushion Adjustment

Needle valves are provided at both ends of the cylinder for precise cushion adjustment, and retained within the head and cap so that they cannot be inadvertently removed. The cartridge type needle valve illustrated below is fitted to cylinders of up to 63.5mm (2½") bore – see page 42.

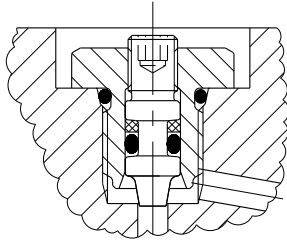

### 10 Check Valve

A check valve is provided at the head end of the cylinder, providing minimum flow restriction at the start of the return stroke. This allows full pressure to be applied to the annular area of the piston, permitting faster cycle times.

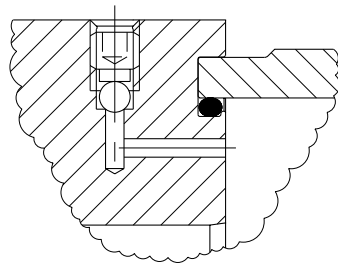

### Piston Seals

**Lipseal Pistons** – A Lipseal piston is fitted to 2A cylinders as standard. It offers a wide piston surface which reduces bearing load, and is suitable for speeds of up to 0.5m/s. Fully dynamic and self-compensating seals allow for variations in pressure, mechanical deflections and wear.

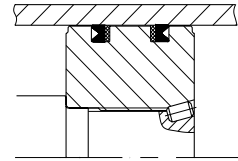

**Non-Lubricated Pistons** – For non-lubricated air cylinders, lipseals with special rounded sealing lips are supplied as standard. Specify Series 2AN (see pages 34-35).

### Seal Groups

Parker offers two classes of seals for 2A and 2AN (non-lubricated air) cylinders:

**Group 1 Seals** are standard and are suitable for air or nitrogen. The temperature range for Group 1 seals is -20°C to +80°C.

**Group 5 Seals** are made from fluorocarbon elastomers and extend the working temperature for 2A cylinders from -15°C up to 150°C, or 204°C with reduced life. For non-lubricated air cylinders in high temperature applications, please refer to page 35.

### Special Designs

Parker's design and engineering staff are available to produce special designs to meet customer's specific requirements. Alternative sealing arrangements, special mounting styles, different bores and rod sizes are just a few of the custom features which can be supplied.

### Standard Specifications

- Heavy-duty service – NFPA specifications
- Standard construction – square head – 4 tie rod design
- Standard pressure – to 18 bar (250 psi) dependent on bore size
- Standard medium – filtered and lubricated air
- Standard temperature – -20°C to +80°C
- Hard chrome-plated bore
- Bore sizes – 25.4mm (1") to 355.6mm (14")
- Piston rod diameters – 12.7mm (½") to 139.7mm (5½")
- Mounting styles – 15 standard styles
- Strokes – available in any practical stroke length
- Cushions – optional at either end or both ends of stroke
- Rod ends – three standard choices – specials to order

**Check List**

The following check list indicates the principal factors which should be considered when selecting a pneumatic cylinder for a particular application. Further information is available on the pages shown. If more detailed information is required about any aspect of a cylinder's specification, please contact our design engineers who will be happy to assist.

**inPHorm**

The European Cylinder inPHorm program can assist with the selection and specification of an hydraulic cylinder for a particular application. Please ask for HY07-1260/Eur.

- 1 Establish System Parameters** ..... **Series 2A**

  - Weight to be moved and force required
  - Nominal operating pressure and range
  - Distance to be travelled
  - Average and maximum piston speed
  
- 2 Mounting Style** ..... **Page 7**

Select the appropriate style for the specific application
  
- 3 Cylinder Bore and Operating Pressure** ..... **Pages 37, 38**

Determine the bore and system pressure required to provide the necessary force
  
- 4 Piston Rod** ..... **Pages 20, 30, 38, 39, 40**

  - Single or double rod?
  - Determine the minimum rod diameter required to withstand buckling forces
  - Is a stop tube required?
  - Select a suitable rod end and rod end thread
  - Check pressure rating of selected cylinder and piston rod
  
- 5 Piston** ..... **Page 5**

  - Does seal type suit application?
  - (eg: Lipseal for 2A cylinders, Non-Lubricated for 2AN cylinders)
  
- 6 Cushioning** ..... **Page 41**

Select cushioning requirements if applicable
  
- 7 Ports** ..... **Page 42**

  - Select suitable ports
  - Are the standard positions acceptable?
  
- 8 Seals** ..... **Page 5**

Select seals to suit the chosen temperature range
  
- 9 Rod and Cap End Accessories** ..... **Pages 31-33**

Are rod end and/or cap end accessories required?
  
- 10 Optional Features** ..... **Page 43**

Removable trunnions, rod end bellows etc.



## Mounting Styles

### Mounting Styles and Where to Use Them

See also application-specific mounting information on page 36.

#### Extended Tie Rod Mountings – Styles TB, TC and TD

##### Application

- straight line force transfer
- compression (push) – use cap end mountings TC or TD
- tension (pull) – use head end mountings TB or TD

##### Benefits

- ease of mounting where space is limited
- high efficiency – force is absorbed on cylinder's centre line
- TD double-ended mounting allows brackets or switches to be attached to cylinder

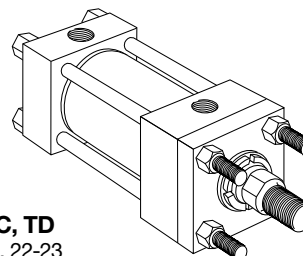

**Styles TB, TC, TD**  
See pages 8-9, 22-23

TB

#### Flange Mountings – Styles J, JB, H, HB

##### Application

- straight line force transfer
- compression (push) – use cap end mounting HH or HB
- tension (pull) – use head end mounting J or JB

##### Benefits

- exceptionally rigid mounting due to large flange area
- high efficiency – force is absorbed on cylinder's centre line

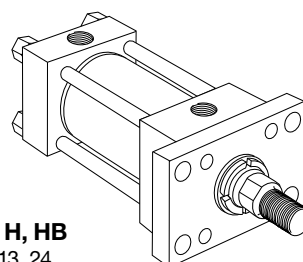

**Styles J, JB, H, HB**  
See pages 10-13, 24

J

#### Foot Mounting – Styles C, F, G

##### Application

- straight line force transfer
- suitable for push or pull applications
- force is **not** absorbed on centre line – secure attachment is vital, eg: a thrust key where applicable (page 36) and effective load guidance

##### Benefits

- ease of mounting and adjustment

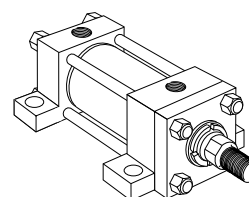

**Styles C, F, G**  
See pages 14-15, 26-27

C

#### Pivot Mountings – Styles BB and BC

##### Application

- curved path force transfer
- movement in a single plane – use fixed clevis styles BB or BC

##### Benefits

- ease of attachment – use with plain or spherical bearing at rod end
- greater flexibility for the machine designer
- self-alignment resists wear of cylinder's bearing surfaces

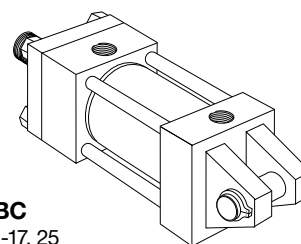

**Styles BB, BC**  
See pages 16-17, 25

BB

#### Trunnion Mountings – Styles D, DB and DD

##### Application

- curved path force transfer
- movement in a single plane
- compression (push) – use DB or DD mountings
- tension (pull) – use D or DD mountings

##### Benefits

- greater flexibility for the machine designer
- self-alignment resists wear of cylinder's bearing surfaces
- high efficiency – force is absorbed on cylinder's centre line
- ease of attachment – use with pivot mounting at rod end

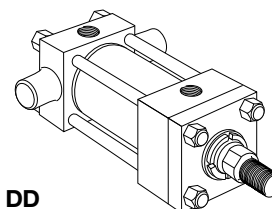

**Styles D, DB, DD**  
See pages 18-19, 28-29

DB

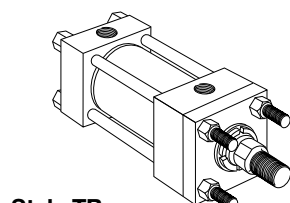

**Style TB**  
Tie Rods Extended Head End  
(NFA Style MX3)

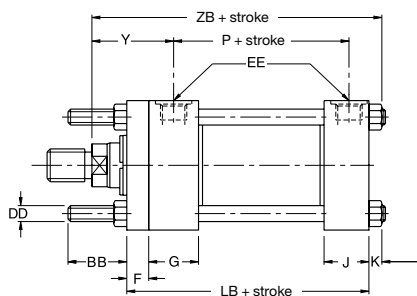

See Notes 1, 2, 3, 4, 5

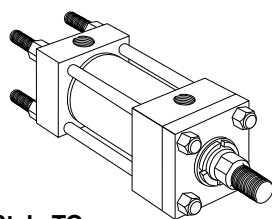
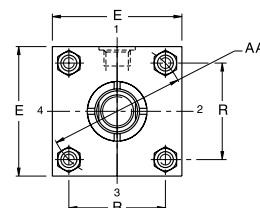

**Style TC**  
Tie Rods Extended Cap End  
(NFA Style MX2)

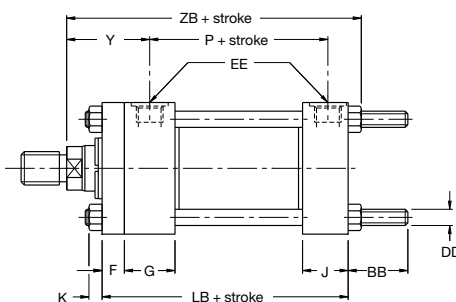

See Notes 1, 2, 3, 4, 5

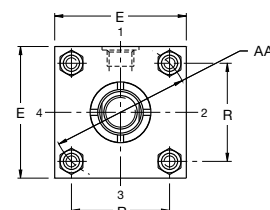
**Dimensions TB, TC & TD** See also Rod End Dimensions, page 20

Bore Ø	Rod No.	AA	BB	DD <sup>1</sup>	E	EE <sup>5</sup> (BSPP)	F	G	H <sup>4</sup>
25.4 (1")	1	38.9	19.1	10-24	38.1 <sup>4</sup>	G <sup>1</sup> / <sub>4</sub>	9.5	38.1	6.4
	2								
38.1 (1½")	1	51.3	25.4	¼-28	50.8 <sup>4</sup>	G <sup>3</sup> / <sub>8</sub>	9.5	38.1	-
	2								
50.8 (2")	1	66.2	28.5	5/16-24	63.5 <sup>4</sup>	G <sup>3</sup> / <sub>8</sub>	9.5	38.1	-
	2								
	3								
63.5 (2½")	1	78.5	28.5	5/16-24	76.2 <sup>4</sup>	G <sup>3</sup> / <sub>8</sub>	9.5	38.1	-
	2								
	3								
	4								
82.6 (3¼")	1	99.1	34.9	¾-24	95.2	G <sup>1</sup> / <sub>2</sub>	15.9	44.5	-
	2								
	3								
	4								
101.6 (4")	1	119.4	34.9	¾-24	114.3	G <sup>1</sup> / <sub>2</sub>	15.9	44.5	-
	2								
	3								
	4								
	5								
127.0 (5")	1	147.2	46.0	½-20	139.7	G <sup>1</sup> / <sub>2</sub>	15.9	44.5	-
	2								
	3								
	4								
	5								
	6								
	7								
152.4 (6")	1	175.4	46.0	½-20	165.1	G <sup>3</sup> / <sub>4</sub>	19.1	50.8	-
	2								
	3								
	4								
	5								
	6								
	7								

All dimensions are in millimetres unless otherwise stated.



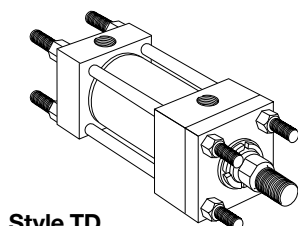

**Style TD**  
Tie Rods Extended Both Ends  
(NFA Style MX1)

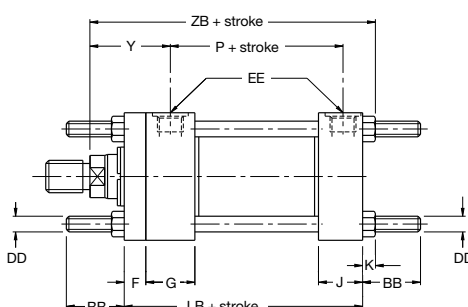

See Notes 1, 2, 3, 4, 5

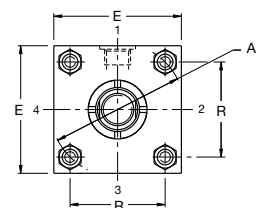
**Notes**

- All tie rod threads (dimension DD) are UNF, with the exception of 25.4mm (1") bore which is UNC.
- Mounting nuts should be tightened to the torque values shown for tie rod nuts – see page 37.
- For Styles TB and TC an additional set of mounting nuts are supplied. For Style TD, two additional sets of mounting nuts are supplied.
- The extra height 'H' of the port face applies to the head end of the bore and rod sizes shown in the table below and to the cap end of 38.1mm (1½") bore cylinders only.
- R1 size BSPP ports to ISO 228/1 are supplied as standard on 2A cylinders. For smaller R2 size ports, please see page 42.

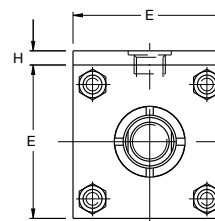
**Dimensions TB, TC & TD Continued**

Bore Ø	Rod No.	J	K	R	Y	+ stroke		
						LB	P	ZB max
25.4 (1")	1	25.4	5.0	27.4	49	98.4	54	119.3
	2				49			119.3
38.1 (1½")	1	25.4	6.4	36.3	49	101.6	58	123.8
	2				58			133.4
50.8 (2")	1	25.4	7.5	46.7	49	101.6	58	125.8
	2				65			141.7
	3				58			135.3
63.5 (2½")	1	25.4	7.5	55.6	49	104.8	61	129.0
	2				71			151.2
	3				58			138.4
	4				65			144.9
82.6 (3¼")	1	31.7	10.0	70.1	58	123.8	70	152.9
	2				74			168.8
	3				65			159.3
	4				71			165.6
101.6 (4")	1	31.7	10.0	84.3	58	123.8	70	152.9
	2				81			175.1
	3				65			159.3
	4				71			165.6
	5				74			168.8
127.0 (5")	1	31.7	13.0	104.1	58	130.2	77	162.2
	2				81			184.0
	3				65			168.6
	4				71			174.9
	5				74			178.1
	6				81			184.5
	7				81			184.5
152.4 (6")	1	38.1	13.0	123.9	68	146.1	83	181.3
	2				84			197.2
	3				74			187.6
	4				78			191.8
	5				84			197.2
	6				84			197.2
	7				84			197.2

All dimensions are in millimetres unless otherwise stated.



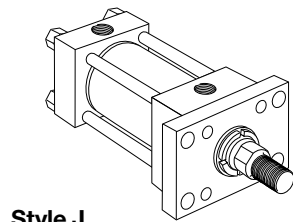

**Style J**  
Head Rectangular Flange  
(NFA Style MF1)

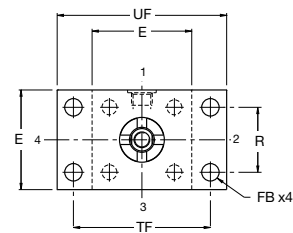
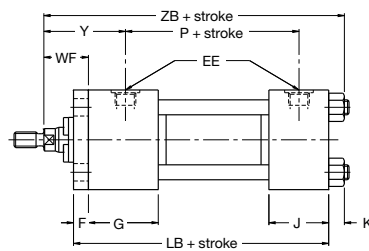

See Notes 1, 2

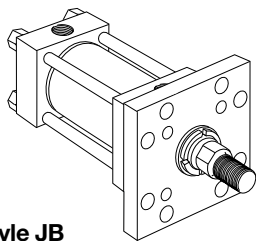

**Style JB**  
Head Square Flange  
(NFA Style MF5)

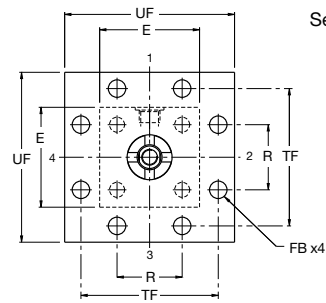
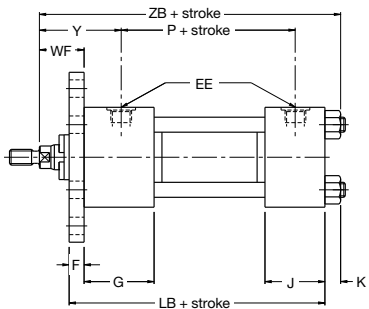

See Notes 1, 2

**Dimensions J & JB** See also Rod End Dimensions, page 20

Bore Ø	Rod No.	E	EE <sup>2</sup> (BSPP)	F	FB	G	H <sup>1</sup>	J	K
25.4 (1")	1	38.1 <sup>1</sup>	G <sup>1</sup> / <sub>4</sub>	9.5	6.4	38.1	6.4	25.4	5.0
	2								
38.1 (1½")	1	50.8 <sup>1</sup>	G <sup>3</sup> / <sub>8</sub>	9.5	7.9	38.1	-	25.4	6.4
	2								
50.8 (2")	1	63.5 <sup>1</sup>	G <sup>3</sup> / <sub>8</sub>	9.5	9.5	38.1	-	25.4	7.5
	2								
	3								
63.5 (2½")	1	76.2 <sup>1</sup>	G <sup>3</sup> / <sub>8</sub>	9.5	9.5	38.1	2.4	25.4	7.5
	2								
	3								
	4								
82.6 (3¼")	1	95.2	G <sup>1</sup> / <sub>2</sub>	15.9	11.1	44.5	-	31.8	10.0
	2								
	3								
	4								
101.6 (4")	1	114.3	G <sup>1</sup> / <sub>2</sub>	15.9	11.1	44.5	-	31.8	10.0
	2								
	3								
	4								
	5								
127.0 (5")	1	139.7	G <sup>1</sup> / <sub>2</sub>	15.9	14.2	44.5	-	31.8	13.0
	2								
	3								
	4								
	5								
	6								
	7								
152.4 (6")	1	165.1	G <sup>3</sup> / <sub>4</sub>	19.1	14.2	50.8	-	38.1	13.0
	2								
	3								
	4								
	5								
	6								
	7								

All dimensions are in millimetres unless otherwise stated.

**Notes**

- 1 The extra height 'H' of the port face applies to the head end of the bore and rod sizes below and to the cap end of 38.1mm (1½") bore cylinders only.
- 2 R1 size BSPP ports to ISO 228/1 are supplied as standard on 2A cylinders. For smaller R2 size ports, please see page 42.

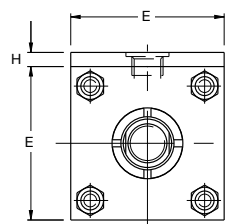
**Dimensions J & JB Continued**

Bore Ø	Rod No.	R	TF	UF	WF	Y	+ stroke		
							LB	P	ZB max
25.4 (1")	1	27.4	50.8	63.5	25.4	49	98.4	54	119.3
	2								119.3
38.1 (1½")	1	36.3	69.8	85.7	25.4	49	101.6	58	123.8
	2								133.4
50.8 (2")	1	46.7	85.7	104.7	25.4	49	101.6	58	125.8
	2								141.7
	3								135.3
63.5 (2½")	1	55.6	98.4	117.4	25.4	49	104.8	61	129.0
	2								151.2
	3								138.4
	4								144.9
82.6 (3¼")	1	70.1	119.0	139.7	34.9	58	123.8	70	152.9
	2								168.8
	3								159.3
	4								165.6
101.6 (4")	1	84.3	138.1	158.7	34.9	58	123.8	70	152.9
	2								175.1
	3								159.3
	4								165.6
	5								168.8
127.0 (5")	1	104.1	168.2	193.7	34.9	58	130.2	77	162.2
	2								184.0
	3								168.6
	4								174.9
	5								178.1
	6								184.5
	7								184.5
152.4 (6")	1	123.9	193.7	219.1	41.3	68	146.1	83	181.3
	2								197.2
	3								187.6
	4								191.8
	5								197.2
	6								197.2
	7								197.2

All dimensions are in millimetres unless otherwise stated.



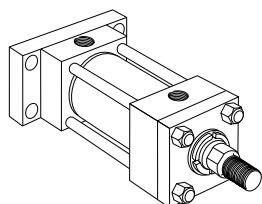

**Style H**  
Cap Rectangular Flange  
(NFA Style MF2)

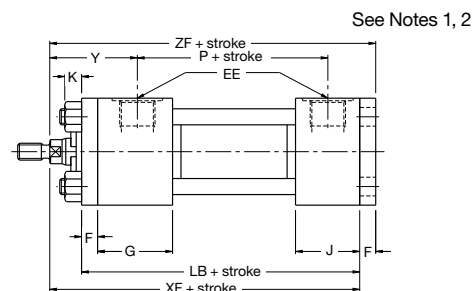
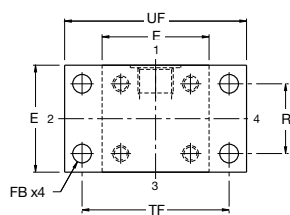

See Notes 1, 2

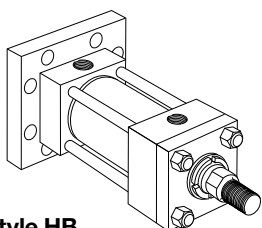

**Style HB**  
Cap Square Flange  
(NFA Style MF6)

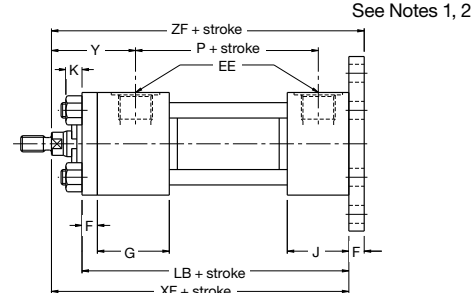
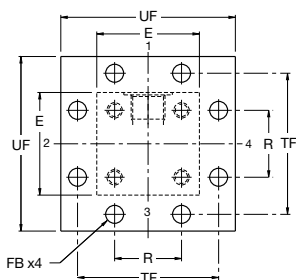

See Notes 1, 2

**Dimensions H & HB** See also Rod End Dimensions, page 20

Bore Ø	Rod No.	E	EE <sup>2</sup> (BSPP)	F	FB	G	H <sup>1</sup>	J	K
25.4 (1")	1	38.1 <sup>1</sup>	G <sup>1</sup> / <sub>4</sub>	9.5	6.4	38.1	6.4	25.4	5.0
	2								
38.1 (1½")	1	50.8 <sup>1</sup>	G <sup>3</sup> / <sub>8</sub>	9.5	7.9	38.1	-	25.4	6.4
	2								
50.8 (2")	1	63.5 <sup>1</sup>	G <sup>3</sup> / <sub>8</sub>	9.5	9.5	38.1	-	25.4	7.5
	2								
	3								
63.5 (2½")	1	76.2 <sup>1</sup>	G <sup>3</sup> / <sub>8</sub>	9.5	9.5	38.1	2.4	25.4	7.5
	2								
	3								
	4								
82.6 (3¼")	1	95.2	G <sup>1</sup> / <sub>2</sub>	15.9	11.1	44.5	-	31.8	10.0
	2								
	3								
	4								
101.6 (4")	1	114.3	G <sup>1</sup> / <sub>2</sub>	15.9	11.1	44.5	-	31.8	10.0
	2								
	3								
	4								
	5								
127.0 (5")	1	139.7	G <sup>1</sup> / <sub>2</sub>	15.9	14.2	44.5	-	31.8	13.0
	2								
	3								
	4								
	5								
	6								
	7								
152.4 (6")	1	165.1	G <sup>3</sup> / <sub>4</sub>	19.1	14.2	50.8	-	38.1	13.0
	2								
	3								
	4								
	5								
	6								
	7								

All dimensions are in millimetres unless otherwise stated.



**Notes**

- 1 The extra height 'H' of the port face applies to the head end of the bore and rod sizes shown below and to the cap end of 38.1mm (1½") bore cylinders only.
- 2 R1 size BSPP ports to ISO 228/1 are supplied as standard on 2A cylinders. For smaller R2 size ports, please see page 42.

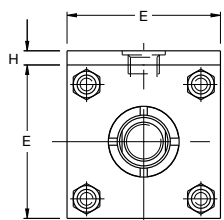
**Dimensions H & HB Continued**

Bore Ø	Rod No.	R	TF	UF	Y	+ stroke			
						LB	P	XF	ZF
25.4 (1")	1	27.4	50.8	63.5	49	98.4	54	114.3	123.8
	2				114.3				123.8
38.1 (1½")	1	36.3	69.8	85.7	49	101.6	58	117.5	127.0
	2				127.0				136.5
50.8 (2")	1	46.7	85.7	104.7	49	101.6	58	117.5	127.0
	2				133.4				142.9
	3				127.0				136.5
63.5 (2½")	1	55.6	98.4	117.4	49	104.8	61	120.7	130.2
	2				142.9				152.4
	3				130.2				139.7
	4				136.5				146.1
82.6 (3¼")	1	70.1	119.0	139.7	58	123.8	70	142.9	158.8
	2				158.8				174.6
	3				149.2				165.1
	4				155.6				171.5
101.6 (4")	1	84.3	138.1	158.7	58	123.8	70	142.9	158.8
	2				165.1				181.0
	3				149.2				165.1
	4				155.6				171.5
	5				158.8				174.6
127.0 (5")	1	104.1	168.2	193.7	58	130.2	77	149.2	165.1
	2				171.5				187.3
	3				155.6				171.5
	4				161.9				177.8
	5				165.1				181.0
	6				171.5				187.3
	7				171.5				187.3
152.4 (6")	1	123.9	193.7	219.1	68	146.1	83	168.3	187.3
	2				184.2				203.2
	3				174.6				193.7
	4				177.8				196.9
	5				184.2				203.2
	6				184.2				203.2
	7				184.2				203.2

All dimensions are in millimetres unless otherwise stated.



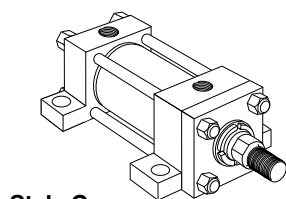
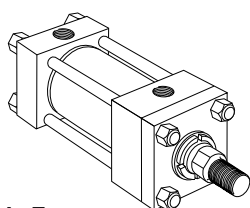
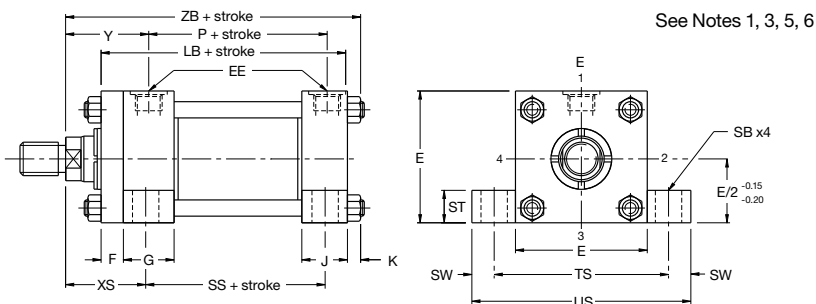
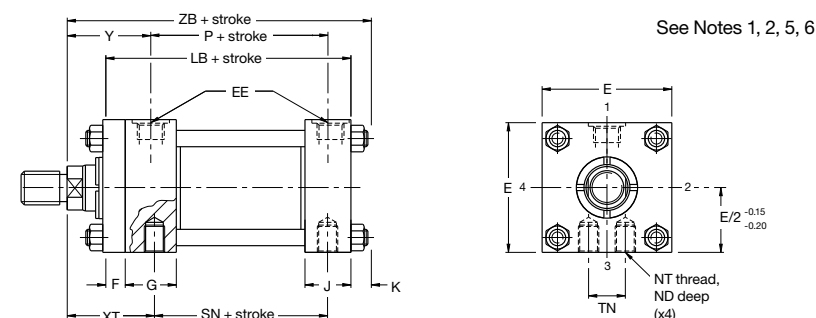

**Style C**  
 Side Lug Mounting  
 (NFA Style MS2)

**Style F**  
 Side Tapped Mounting  
 (NFA Style MS4)

**Dimensions C, F & G** See also Rod End Dimensions, page 20

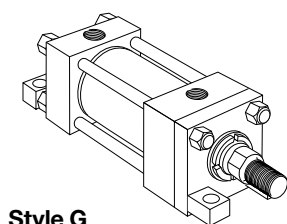
Bore Ø	Rod No.	E	EB	EE <sup>6</sup> (BSPP)	EL	EO	ES	ET	F	G	H <sup>5</sup>	J	K	ND	NT <sup>2</sup>	R	SB <sup>3</sup>
25.4 (1")	1	38.1 <sup>5</sup>	-	G <sup>1</sup> / <sub>4</sub>	-	-	-	-	9.5	38.1	6.4	25.4	5.0	6.4	M5	-	6.6
	6.4																
38.1 (1½")	1	50.8 <sup>5</sup>	9.0	G <sup>3</sup> / <sub>8</sub>	19.1	6.4	14	14.3	9.5	38.1	-	25.4	6.4	9.5	M6	36.3	11.0
	4.8																
50.8 (2")	1	63.5 <sup>5</sup>	9.5	G <sup>3</sup> / <sub>8</sub>	23.8	7.9	16	19.1	9.5	38.1	2.4	25.4	7.5	9.5	M8	46.7	11.0
	2													9.5			
	3													9.5			
63.5 (2½")	1	76.2 <sup>5</sup>	9.5	G <sup>3</sup> / <sub>8</sub>	27.0	7.9	20	22.2	9.5	38.1	-	25.4	7.5	12.7	M10	55.6	11.0
	2													11.1			
	3													12.7			
	4													12.7			
82.6 (3¼")	1	95.2	11.1	G <sup>1</sup> / <sub>2</sub>	22.2	9.5	25	25.4	15.9	44.5	-	31.8	10.0	19.1	M12	70.1	14.0
	2													12.7			
	3													19.1			
	4													19.1			
101.6 (4")	1	114.3	11.1	G <sup>1</sup> / <sub>2</sub>	25.4	9.5	32	31.8	15.9	44.5	-	31.8	10.0	19.1	M12	84.3	14.0
	2													15.9			
	3													19.1			
	4													19.1			
	5													19.1			
127.0 (5")	1	139.7	14.2	G <sup>1</sup> / <sub>2</sub>	27.0	12.7	35	38.1	15.9	44.5	-	31.8	13.0	23.8	M16	104.1	22.0
	2													19.1			
	3													23.8			
	4													23.8			
	5													23.8			
	6													23.8			
	7													23.8			
152.4 (6")	1	165.1	14.2	G <sup>3</sup> / <sub>4</sub>	25.4	12.7	45	41.3	19.1	50.8	-	38.1	13.0	28.6	M20	123.9	22.0
	2													22.2			
	3													28.6			
	4													28.6			
	5													28.6			
	6													28.6			
	7													28.6			

All dimensions are in millimetres unless otherwise stated.





**Style G**  
Side End Lug  
(NFA Style MS7)

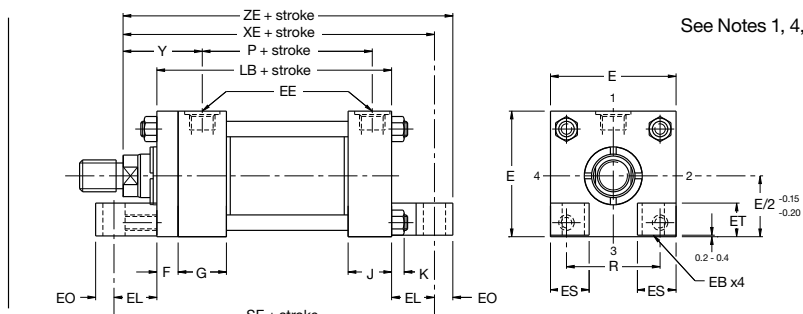

See Notes 1, 4, 5, 6

**Notes**

- 1 Consider the use of a thrust key with this mounting – see page 36.
- 2 Tapped mounting holes are metric (coarse pitch series).
- 3 Upper surfaces of lugs are machined for socket head screws.
- 4 Not available in 25.4mm (1") bore sizes.
- 5 The extra height 'H' of the port face applies to the head end of the bore and rod sizes shown below and to the cap end of 38.1mm (1½") bore cylinders only.
- 6 R1 size BSPP ports to ISO 228/1 are supplied as standard on 2A cylinders. For smaller R2 size ports, please see page 42.

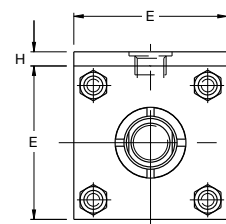
**Dimensions C, F & G Continued**

Bore Ø	Rod No.	ST	SW	TN	TS	US	XS	XT	Y	+ stroke							
										LB	P	SE	SN	SS	XE	ZB max	ZE
25.4 (1")	1	7.9	7.9	13.5	54.0	69.9	33.3	49.2	49	98.4	54	-	54.0	73.0	-	119.3	-
	2																
38.1 (1½")	1	12.7	9.5	15.5	70.0	88.9	34.9	49.2	49	101.6	58	139.7	57.2	73.0	136.5	123.8	142.9
	2																
50.8 (2")	1	12.7	9.5	22.0	82.6	101.6	34.9	49.2	49	101.6	58	149.2	57.2	73.0	141.3	125.8	149.2
	2																
63.5 (2½")	1	12.7	9.5	31.0	95.3	114.3	34.9	49.2	49	104.8	61	158.8	60.3	76.2	147.6	129.0	155.6
	2																
82.6 (3¼")	1	19.1	12.7	38.0	120.7	146.1	47.6	61.9	58	123.8	70	168.3	66.7	82.6	165.1	152.9	174.6
	2																
101.6 (4")	1	19.1	12.7	52.0	139.7	165.1	47.6	61.9	58	123.8	70	174.6	66.7	82.6	168.2	152.9	177.8
	2																
127.0 (5")	1	25.4	17.5	66.0	174.6	209.5	52.4	61.9	58	130.2	77	184.2	73.0	79.4	176.2	162.2	188.9
	2																
152.4 (6")	1	25.4	17.5	80.0	200.0	235.0	58.6	71.4	68	146.1	83	196.9	79.4	92.1	193.7	181.3	206.4
	2																
	3						65.1	77.8	74						200.0	187.6	212.7
	4																
	5						74.6	87.3	84						209.6	197.2	222.3
	6																
	7						74.6	87.3	84						209.6	197.2	222.3

All dimensions are in millimetres unless otherwise stated.



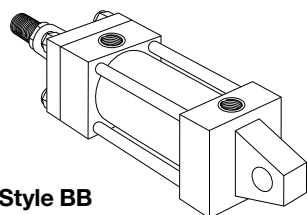

**Style BB**  
Cap Fixed Eye  
25.4mm (1") bore only  
(NFPA Style MP1)

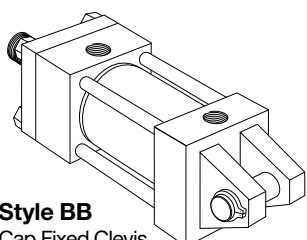
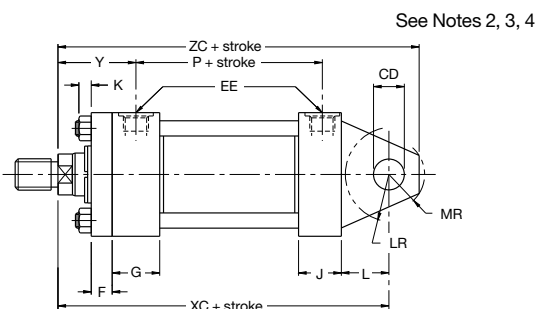
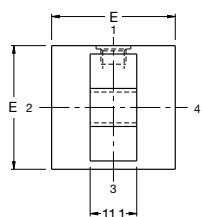

**Style BB**  
Cap Fixed Clevis  
Excluding 25.4mm (1") bore  
(NFPA Style MP1)

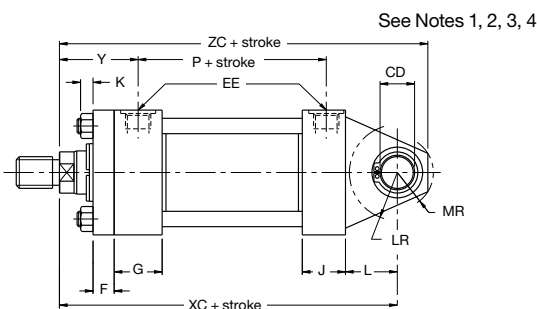
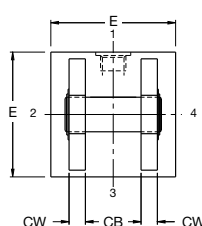
**Dimensions BB & BC** See also Rod End Dimensions, page 20

Bore Ø	Rod No.	CB	CD <sup>1</sup>	<sup>+0.00</sup> <sub>-0.05</sub>	CW	E	EE <sup>4</sup> (BSPP)	F	G	H <sup>3</sup>	J	K
25.4 (1")	1	-	11.13	-	-	38.1 <sup>3</sup>	G <sup>1</sup> / <sub>4</sub>	9.5	38.1	6.4	25.4	5.0
	2	-	11.13	-	-	38.1 <sup>3</sup>	G <sup>1</sup> / <sub>4</sub>	9.5	38.1	6.4	25.4	5.0
38.1 (1½")	1	19.9	12.73	12.7	50.8 <sup>3</sup>	G <sup>3</sup> / <sub>8</sub>	9.5	38.1	-	3.2	25.4	6.4
	2	19.9	12.73	12.7	50.8 <sup>3</sup>	G <sup>3</sup> / <sub>8</sub>	9.5	38.1	-	3.2	25.4	6.4
50.8 (2")	1	19.9	12.73	12.7	63.5 <sup>3</sup>	G <sup>3</sup> / <sub>8</sub>	9.5	38.1	-	2.4	25.4	7.5
	2	19.9	12.73	12.7	63.5 <sup>3</sup>	G <sup>3</sup> / <sub>8</sub>	9.5	38.1	-	2.4	25.4	7.5
	3	19.9	12.73	12.7	63.5 <sup>3</sup>	G <sup>3</sup> / <sub>8</sub>	9.5	38.1	-	2.4	25.4	7.5
63.5 (2½")	1	19.9	12.73	12.7	76.2 <sup>3</sup>	G <sup>3</sup> / <sub>8</sub>	9.5	38.1	-	2.4	25.4	7.5
	2	19.9	12.73	12.7	76.2 <sup>3</sup>	G <sup>3</sup> / <sub>8</sub>	9.5	38.1	-	2.4	25.4	7.5
	3	19.9	12.73	12.7	76.2 <sup>3</sup>	G <sup>3</sup> / <sub>8</sub>	9.5	38.1	-	2.4	25.4	7.5
	4	19.9	12.73	12.7	76.2 <sup>3</sup>	G <sup>3</sup> / <sub>8</sub>	9.5	38.1	-	2.4	25.4	7.5
82.6 (3¼")	1	32.6	19.08	15.8	95.2	G <sup>1</sup> / <sub>2</sub>	15.9	44.5	-	-	31.8	10.0
	2	32.6	19.08	15.8	95.2	G <sup>1</sup> / <sub>2</sub>	15.9	44.5	-	-	31.8	10.0
	3	32.6	19.08	15.8	95.2	G <sup>1</sup> / <sub>2</sub>	15.9	44.5	-	-	31.8	10.0
	4	32.6	19.08	15.8	95.2	G <sup>1</sup> / <sub>2</sub>	15.9	44.5	-	-	31.8	10.0
101.6 (4")	1	32.6	19.08	15.8	114.3	G <sup>1</sup> / <sub>2</sub>	15.9	44.5	-	-	31.8	10.0
	2	32.6	19.08	15.8	114.3	G <sup>1</sup> / <sub>2</sub>	15.9	44.5	-	-	31.8	10.0
	3	32.6	19.08	15.8	114.3	G <sup>1</sup> / <sub>2</sub>	15.9	44.5	-	-	31.8	10.0
	4	32.6	19.08	15.8	114.3	G <sup>1</sup> / <sub>2</sub>	15.9	44.5	-	-	31.8	10.0
	5	32.6	19.08	15.8	114.3	G <sup>1</sup> / <sub>2</sub>	15.9	44.5	-	-	31.8	10.0
127.0 (5")	1	32.6	19.08	15.8	139.7	G <sup>1</sup> / <sub>2</sub>	15.9	44.5	-	-	31.8	13.0
	2	32.6	19.08	15.8	139.7	G <sup>1</sup> / <sub>2</sub>	15.9	44.5	-	-	31.8	13.0
	3	32.6	19.08	15.8	139.7	G <sup>1</sup> / <sub>2</sub>	15.9	44.5	-	-	31.8	13.0
	4	32.6	19.08	15.8	139.7	G <sup>1</sup> / <sub>2</sub>	15.9	44.5	-	-	31.8	13.0
	5	32.6	19.08	15.8	139.7	G <sup>1</sup> / <sub>2</sub>	15.9	44.5	-	-	31.8	13.0
	6	32.6	19.08	15.8	139.7	G <sup>1</sup> / <sub>2</sub>	15.9	44.5	-	-	31.8	13.0
	7	32.6	19.08	15.8	139.7	G <sup>1</sup> / <sub>2</sub>	15.9	44.5	-	-	31.8	13.0
152.4 (6")	1	39.0	25.43	19.1	165.1	G <sup>3</sup> / <sub>4</sub>	19.1	50.8	-	-	38.1	13.0
	2	39.0	25.43	19.1	165.1	G <sup>3</sup> / <sub>4</sub>	19.1	50.8	-	-	38.1	13.0
	3	39.0	25.43	19.1	165.1	G <sup>3</sup> / <sub>4</sub>	19.1	50.8	-	-	38.1	13.0
	4	39.0	25.43	19.1	165.1	G <sup>3</sup> / <sub>4</sub>	19.1	50.8	-	-	38.1	13.0
	5	39.0	25.43	19.1	165.1	G <sup>3</sup> / <sub>4</sub>	19.1	50.8	-	-	38.1	13.0
	6	39.0	25.43	19.1	165.1	G <sup>3</sup> / <sub>4</sub>	19.1	50.8	-	-	38.1	13.0
	7	39.0	25.43	19.1	165.1	G <sup>3</sup> / <sub>4</sub>	19.1	50.8	-	-	38.1	13.0

All dimensions are in millimetres unless otherwise stated.



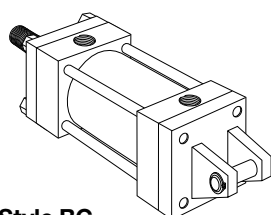

**Style BC**  
Cap Detachable Clevis  
(NFPA Style MP2)

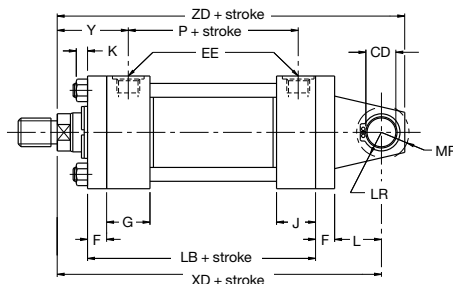
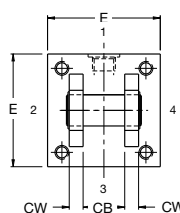

See Notes 1, 2, 3, 4

**Notes**

- 1 Dimension CD is the pivot pin diameter except for 25.4mm (1") bore. Style BB and BC cylinders of 38.1mm (1 1/2") bores and above are supplied complete with a pivot pin.
- 2 On 25.4mm (1") bore size styles BB and BC a single lug is fitted, as shown above. Dimension CD is the crosshole diameter – the pivot pin is not included.
- 3 The extra height 'H' of the port face applies to the head end of the bore and rod sizes shown below and to the cap end of 38.1mm (1 1/2") bore cylinders only.
- 4 R1 size BSPP ports to ISO 228/1 are supplied as standard on 2A cylinders. For smaller R2 size ports, please see page 42.

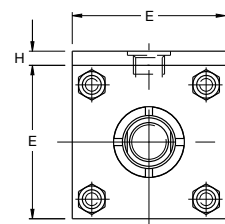
**Dimensions BB & BC Continued**

Bore Ø	Rod No.	L	LR	MR	Y	+ stroke					
						LB	P	XC	XD	ZC	ZD
25.4 (1")	1	12.7	12.7	12.7	49	98.4	54	127.0	136.5	138.1	147.6
	127.0							136.5	138.1	147.6	
38.1 (1 1/2")	1	19.1	15.9	15.9	49	101.6	58	136.5	146.1	149.2	158.8
	146.1							155.6	158.8	168.3	
50.8 (2")	2	19.1	15.9	15.9	49	101.6	58	136.5	146.1	149.2	158.8
	3				65			152.4	161.9	165.1	174.6
	4				58			146.1	155.6	158.7	168.3
63.5 (2 1/2")	1	19.1	15.9	15.9	49	104.8	61	139.7	149.2	152.4	161.9
	2				71			161.9	171.5	174.6	184.2
	3				58			149.2	158.8	161.9	171.5
	4				65			155.6	165.1	168.2	177.8
82.6 (3 1/4")	1	31.8	25.4	23.8	58	123.8	70	174.6	190.5	193.7	209.6
	2				74			190.5	206.4	209.6	225.4
	3				65			181.0	196.9	200.0	215.9
	4				71			187.3	203.2	206.4	222.3
101.6 (4")	1	31.8	25.4	23.8	58	123.8	70	174.6	190.5	193.7	209.6
	2				81			196.9	212.7	215.9	231.8
	3				65			181.0	196.9	200.0	215.9
	4				71			187.3	203.2	206.4	222.3
	5				74			190.5	206.4	209.6	225.4
127.0 (5")	1	31.8	25.4	23.8	58	130.2	77	181.0	196.9	200.6	215.9
	2				81			203.2	219.1	222.3	238.1
	3				65			187.3	203.2	206.4	222.3
	4				71			193.7	209.6	212.7	228.6
	5				74			196.9	212.7	215.9	231.8
	6				81			203.2	219.1	222.3	238.2
	7				81			203.2	219.1	222.3	238.2
152.4 (6")	1	38.1	31.8	30.2	68	146.1	83	206.4	225.4	231.8	251.0
	2				84			222.3	241.3	247.7	266.7
	3				74			212.7	231.8	238.2	257.4
	4				78			215.9	235.0	241.3	260.4
	5				84			222.3	241.3	247.7	266.7
	6				84			222.3	241.3	247.7	266.7
	7				84			222.3	241.3	247.7	266.7

All dimensions are in millimetres unless otherwise stated.



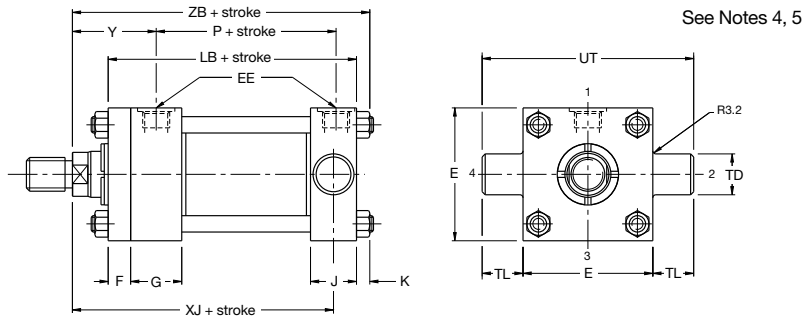
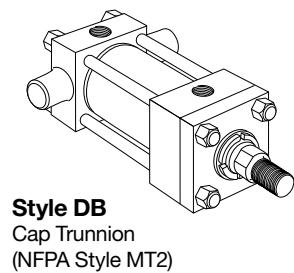
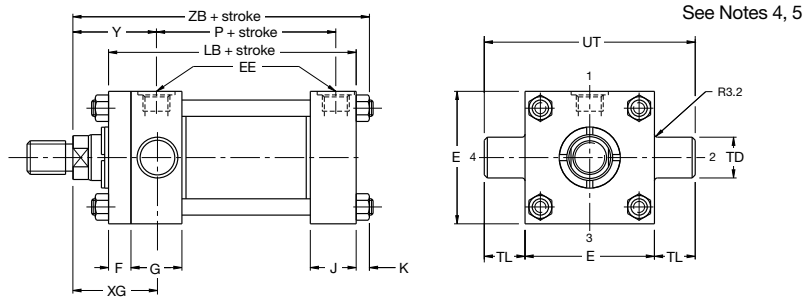
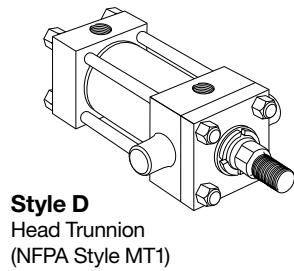

**Dimensions D, DB & DD** See also Rod End Dimensions, page 20

Bore Ø	Rod No.	BD	E	EE <sup>4</sup> (BSPP)	F	G	H <sup>5</sup>	J	K	TD <sup>+0.00</sup> <sup>-0.03</sup>	TL	TM
25.4 (1")	1 2	-	38.1 <sup>5</sup>	G <sup>1</sup> / <sub>4</sub>	9.5	38.1	6.4	25.4	5.0	19.05	19.1	-
38.1 (1½")	1 2	31.7	50.8 <sup>5</sup>	G <sup>3</sup> / <sub>8</sub>	9.5	38.1	- 3.2	25.4	6.4	25.40	25.4	63.5
50.8 (2")	1 2 3	38.1	63.5 <sup>5</sup>	G <sup>3</sup> / <sub>8</sub>	9.5	38.1	2.4 -	25.4	7.5	25.40	25.4	76.2
63.5 (2½")	1 2 3 4	38.1	76.2 <sup>5</sup>	G <sup>3</sup> / <sub>8</sub>	9.5	38.1	2.4 -	25.4	7.5	25.40	25.4	88.9
82.6 (3¾")	1 2 3 4	50.8	95.2	G <sup>1</sup> / <sub>2</sub>	15.9	44.5	-	31.8	10.0	25.40	25.4	114.3
101.6 (4")	1 2 3 4 5	50.8	114.3	G <sup>1</sup> / <sub>2</sub>	15.9	44.5	-	31.8	10.0	25.40	25.4	133.4
127.0 (5")	1 2 3 4 5 6 7	50.8	139.7	G <sup>1</sup> / <sub>2</sub>	15.9	44.5	-	31.8	13.0	25.40	25.4	158.8
152.4 (6")	1 2 3 4 5 6 7	63.5	165.1	G <sup>3</sup> / <sub>4</sub>	19.1	50.8	-	38.1	13.0	34.92	34.9	193.7

All dimensions are in millimetres unless otherwise stated.

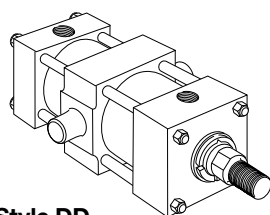



**Style DD**  
Intermediate Fixed Trunnion  
(NFPA Style MT4)

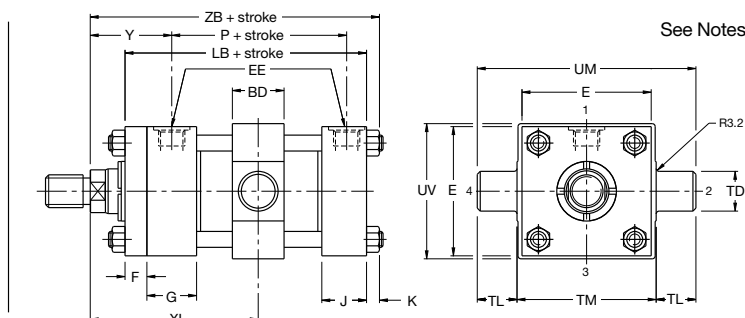

See Notes 1, 2, 3, 4, 5

**Notes**

- Note the minimum stroke from the table below.
- XI dimension to be specified by customer. Please note minimum dimension from the table below.
- Not available in 25.4mm (1") bore size.
- R1 size BSPP ports to ISO 228/1 are supplied as standard on 2A cylinders. For smaller R2 size ports, please see page 42.
- The extra height 'H' of the port face applies to the head end of the bore and rod sizes shown below and to the cap end of 38.1mm (1½") bore cylinders only.

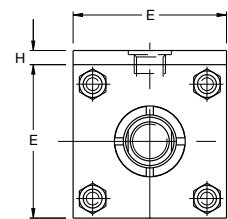
**Dimensions D, DB & DD Continued**

Bore Ø	Rod No.	UM	UT	UV	XG	Min. XI <sup>2</sup>	Y	Style DD min. stroke	+ stroke			
									LB	P	XJ	ZB max
25.4 (1")	1	-	76.2	-	44.5	-	49	-	98.4	54	101.6	119.3
	44.5				101.6		119.3					
38.1 (1½")	1	114.3	101.6	63.5	44.5	80	49	3.2	101.6	58	104.7	123.8
	54.0				89	58	114.3				133.4	
50.8 (2")	1	127.0	114.3	76.2	44.5	83	49	10.0	101.6	58	104.7	125.8
	2				60.3	99	65				120.7	141.7
	3				54.0	93	58				114.3	135.3
63.5 (2½")	1	139.7	127.0	88.9	44.5	83	49	6.4	104.8	61	108.0	129.0
	2				66.7	105	71				130.2	151.2
	3				54.0	93	58				117.4	138.4
	4				60.3	99	65				123.8	144.9
82.6 (3¼")	1	165.1	146.1	108.0	57.2	105	58	20.0	123.8	70	127.0	152.9
	2				73.0	121	74				142.9	168.8
	3				63.5	112	65				133.4	159.3
	4				69.8	118	71				139.7	165.6
101.6 (4")	1	184.2	165.1	127.0	57.2	105	58	20.0	123.8	70	127.0	152.9
	2				79.4	127	81				149.2	175.1
	3				63.5	112	65				133.4	159.3
	4				69.8	118	71				139.7	165.6
	5				73.0	121	74				142.9	168.8
127.0 (5")	1	210.0	190.5	152.4	57.2	105	58	13.0	130.2	77	133.4	162.2
	2				79.4	127	81				155.6	184.0
	3				63.5	112	65				139.7	168.6
	4				69.8	118	71				146.1	174.9
	5				73.0	121	74				149.2	178.1
	6				79.4	127	81				155.6	184.5
7	79.4	127	81	155.6	184.5							
152.4 (6")	1	263.6	235.0	177.8	66.7	124	68	26.0	146.1	83	149.2	181.3
	2				82.6	140	84				165.1	197.2
	3				73.0	131	74				155.6	187.6
	4				76.2	134	78				158.8	191.8
	5				82.6	140	84				165.1	197.2
	6				82.6	140	84				165.1	197.2
	7				82.6	140	84				165.1	197.2

All dimensions are in millimetres unless otherwise stated.



**Rod End Details – 25.4mm to 152.4mm  
(1" to 6") bore sizes only**

Piston Rod End Data for 203.2mm to 355.6mm (8" to 14") bore size cylinders is shown on page 30.

**Rod End Styles 4 & 8**

Style 4 rod ends are recommended for all applications in which the work piece is secured against the rod shoulder. Where the work piece is not shouldered, Style 8 rod ends are recommended. If a rod end style is not specified, Style 4 will be supplied.

**Rod End Style 9**

For applications where a female thread is required.

**Rod End Style 3**

Non-standard piston rod ends are designated 'Style 3'. A dimensional sketch or description should accompany the order. Please specify dimensions KK or CC, and A.

**Rod End Style 4**

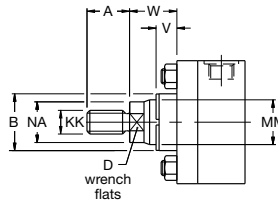

**Rod End Style 8**

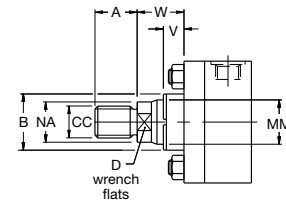

**Rod End Style 9**

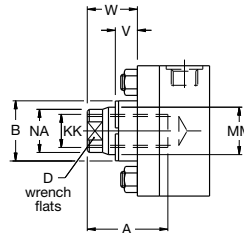

**Rod End Dimensions – 25.4mm to 152.4mm (1" to 6") bore sizes**

Bore Ø	Rod No.	MM Rod Diameter	Styles 4 & 9		Style 8		A	B <sup>+0.00</sup> <sub>-0.05</sub>	D	NA	V	W
			KK Metric	KK UNF <sup>1</sup>	CC Metric	CC UNF						
25.4 (1")	1	12.7 (1/2")	M8x1.25	5/16-24	M10x1.5	7/16-20	15.9	25.37	10	11.1	6.4	15.9
	2	15.9 (5/8")	M10x1.5	7/16-20	M12x1.5	1/2-20	19.0	28.55	13	14.3	6.4	15.9
38.1 (1 1/2")	1	15.9 (5/8")	M10x1.5	7/16-20	M12x1.5	1/2-20	19.0	28.55	13	14.3	6.4	15.9
	2	25.4 (1")	M20x1.5	3/4-16	M22x1.5	7/8-14	28.6	38.07	22	22.6	12.7	25.4
50.8 (2")	1	15.9 (5/8")	M10x1.5	7/16-20	M12x1.5	1/2-20	19.0	28.55	13	14.3	6.4	15.9
	2	34.9 (1 3/8")	M26x1.5	1-14	M30x2	1 1/4-12	41.3	50.77	30	32.2	15.9	31.8
	3	25.4 (1")	M20x1.5	3/4-16	M22x1.5	7/8-14	28.5	38.07	22	22.6	12.7	25.4
63.5 (2 1/2")	1	15.9 (5/8")	M10x1.5	7/16-20	M12x1.5	1/2-20	19.0	28.55	13	14.3	6.4	15.9
	2	44.5 (1 3/4")	M33x2	1 1/4-12	M39x2	1 1/2-12	50.8	60.30	36	41.6	19.1	38.1
	3	25.4 (1")	M20x1.5	3/4-16	M22x1.5	7/8-14	28.5	38.07	22	22.6	12.7	25.4
	4	34.9 (1 3/8")	M26x1.5	1-14	M30x2	1 1/4-12	41.3	50.77	30	32.2	15.9	31.8
82.6 (3 1/4")	1	25.4 (1")	M20x1.5	3/4-16	M22x1.5	7/8-14	28.5	38.07	22	22.6	6.4	19.1
	2	50.8 (2")	M39x2	1 1/2-12	M45x2	1 3/4-12	57.1	66.65	41	48.0	12.7	34.9
	3	34.9 (1 3/8")	M26x1.5	1-14	M30x2	1 1/4-12	41.3	50.77	30	32.2	9.5	25.4
	4	44.5 (1 3/4")	M33x2	1 1/4-12	M39x2	1 1/2-12	50.8	60.30	36	41.6	12.7	31.8
101.6 (4")	1	25.4 (1")	M20x1.5	3/4-16	M22x1.5	7/8-14	28.5	38.07	22	22.6	6.4	19.1
	2	63.5 (2 1/2")	M48x2	1 7/8-12	M56x2	2 1/4-12	76.2	79.35	55	60.3	15.9	41.3
	3	34.9 (1 3/8")	M26x1.5	1-14	M30x2	1 1/4-12	41.3	50.77	30	32.2	9.5	25.4
	4	44.5 (1 3/4")	M33x2	1 1/4-12	M39x2	1 1/2-12	50.8	60.30	36	41.6	12.7	31.8
	5	50.8 (2")	M39x2	1 1/2-12	M45x2	1 3/4-12	57.1	66.65	41	48.0	12.7	34.9
	6	63.5 (2 1/2")	M48x2	1 7/8-12	M56x2	2 1/4-12	76.2	79.35	55	60.3	15.9	41.3
	7	76.2 (3")	M58x2	2 1/4-12	M68x2	2 3/4-12	88.9	95.22	65	73.0	15.9	41.3
127.0 (5")	1	25.4 (1")	M20x1.5	3/4-16	M22x1.5	7/8-14	28.5	38.07	22	22.6	6.4	19.1
	2	88.9 (3 1/2")	M64x2	2 1/2-12	M76x2	3 1/4-12	88.9	107.92	75	85.7	15.9	41.3
	3	34.9 (1 3/8")	M26x1.5	1-14	M30x2	1 1/4-12	41.3	50.77	30	32.2	9.5	25.4
	4	44.5 (1 3/4")	M33x2	1 1/4-12	M39x2	1 1/2-12	50.8	60.30	36	41.6	12.7	31.8
	5	50.8 (2")	M39x2	1 1/2-12	M45x2	1 3/4-12	57.1	66.65	41	48.0	12.7	34.9
	6	63.5 (2 1/2")	M48x2	1 7/8-12	M56x2	2 1/4-12	76.2	79.35	55	60.3	15.9	41.3
	7	76.2 (3")	M58x2	2 1/4-12	M68x2	2 3/4-12	88.9	95.22	65	73.0	15.9	41.3
152.4 (6")	1	34.9 (1 3/8")	M26x1.5	1-14	M30x2	1 1/4-12	41.3	50.77	30	32.2	6.4	22.2
	2	101.6 (4")	M76x2	3-12	M95x2	3 3/4-12	101.6	120.62	85	98.4	12.7	38.1
	3	44.5 (1 3/4")	M33x2	1 1/4-12	M39x2	1 1/2-12	50.8	60.30	36	41.6	9.5	28.6
	4	50.8 (2")	M39x2	1 1/2-12	M45x2	1 3/4-12	57.1	66.65	41	48.0	9.5	31.8
	5	63.5 (2 1/2")	M48x2	1 7/8-12	M56x2	2 1/4-12	76.2	79.35	55	60.3	12.7	38.1
	6	76.2 (3")	M58x2	2 1/4-12	M68x2	2 3/4-12	88.9	95.22	65	73.0	12.7	38.1
	7	88.9 (3 1/2")	M64x2	2 1/2-12	M76x2	3 1/4-12	88.9	107.92	75	85.7	12.7	38.1

<sup>1</sup> All rod threads are UNF except 1-14 which is UNS.

All dimensions are in millimetres unless otherwise stated.

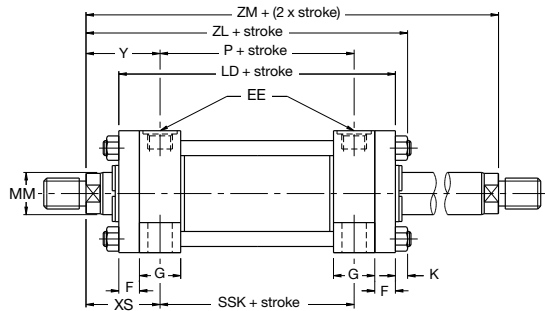

**Double Rod Cylinders – 25.4 to 152.4mm Bore Sizes**

Available with styles TB, TD, J, JB, C, F, G, D, DD

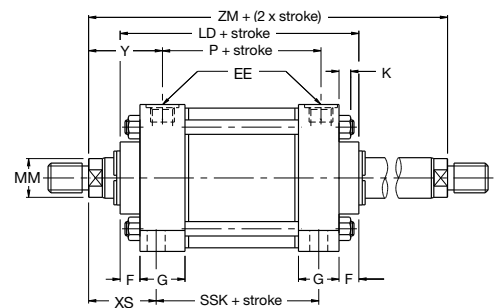
**Double Rod Cylinders – 203.2 to 355.6mm Bore Sizes**

Available with styles TB, TD, JB, C, F, G, D, DD

**Mounting Styles and Codes**

Double rod cylinders are denoted by a 'K' in the model code, shown on page 47.

**Dimensions**

To obtain dimensional information for double rod cylinders, first select the desired mounting style by referring to the corresponding single rod models shown on the preceding pages. Dimensions for the appropriate single rod model should be supplemented by those from the table opposite to provide a full set of dimensions.

**Rod Strength**

Double rod cylinders employ two separate piston rods, with one screwed into the end of the other within the piston rod assembly. As a result, one piston rod is stronger than the other. The stronger rod is identified by the letter 'K' stamped on its end.

**Combination Rods**

Double rod cylinders with rods of differing rod diameters are also available. Please contact the factory for details.

**Cushioning**

Double rod cylinders can be supplied with cushions at either or both ends. Cushioning requirements should be specified by inserting a 'C' in the ordering code – see page 47. Double rod cylinders that require cushioning are supplied with floating cushion sleeves at both ends.

**Style 9 Rod Ends**

If a stroke of less than 25mm on bore sizes up to 82.6mm (3 1/4"), or a stroke of less than 100mm on bore sizes of 101.6mm (4") and over, is required, where Style 9 rod ends are required at both ends, please consult the factory.

Bore Ø	Rod No.	MM Rod Diameter	+ stroke			+ 2x stroke
			LD	ZL	SSK	ZM
25.4 (1")	1	12.7 (1/2")	120.7	139.7	85.7	152.4
38.1 (1 1/2")	1	15.9 (5/8")	123.8	146.1	85.7	155.6
50.8 (2")	1	15.9 (5/8")	123.8	147.6	85.7	155.6
63.5 (2 1/2")	1	15.9 (5/8")	127.0	150.8	88.9	158.8
82.6 (3 1/4")	1	25.4 (1")	152.4	181.0	95.3	190.6
101.6 (4")	1	25.4 (1")	152.4	181.0	95.3	190.5
127.0 (5")	1	25.4 (1")	158.8	188.9	92.1	196.9
152.4 (6")	1	34.9 (1 3/8")	178.0	211.1	104.8	222.3
203.2 (8")	1	34.9 (1 3/8")	181.0	–	108.0	225.4
254.0 (10")	1	44.5 (1 3/4")	206.4	–	123.8	263.5
304.8 (12")	1	50.8 (2")	219.1	–	136.5	282.6
355.6 (14")	1	63.5 (2 1/2")	257.2	–	161.9	333.4

All dimensions apply to rod no. 1 only. For alternative rod sizes, please consult the factory.

All dimensions are in millimetres unless otherwise stated.



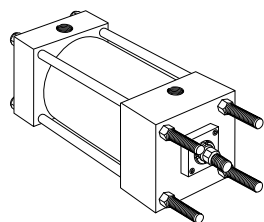

**Style TB**  
Tie Rods Extended Head End  
(NFFA Style MX3)

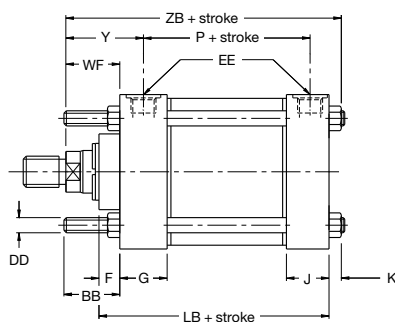

See Notes 1, 2, 3

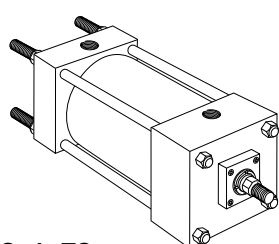
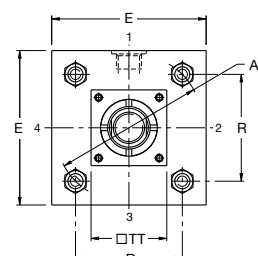

**Style TC**  
Tie Rods Extended Cap End  
(NFFA Style MX2)

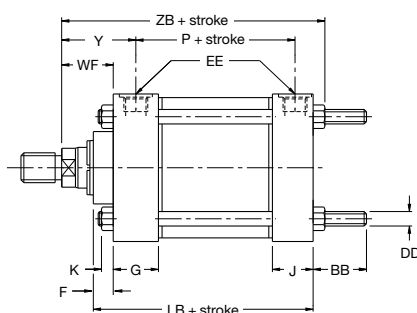

See Notes 1, 2, 3

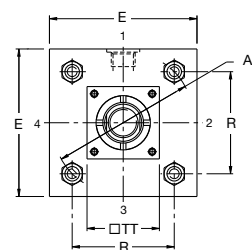

**Dimensions TB, TC & TD** See also Rod End Dimensions, page 30

Bore Ø	Rod No.	AA	BB	DD <sup>1</sup>	E	EE <sup>3</sup> (BSPP)	F	G	J
203.2 (8")	1	231.1	58.7	5/8 - 18	215.9	G <sup>3</sup> / <sub>4</sub>	19.1	50.8	38.1
	2								
	3								
	4								
	5								
	6								
	7								
	8								
254.0 (10")	1	284.5	68.3	3/4 - 16	269.9	G1	19.1	57.2	50.8
	3								
	4								
	5								
	6								
	7								
	9								
	0								
304.8 (12")	1	337.8	68.3	3/4 - 16	323.9	G1	19.1	57.2	50.8
	3								
	4								
	5								
	6								
	8								
	9								
	355.6 (14")								
3									
4									
5									
7									
8									

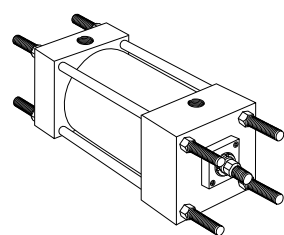
All dimensions are in millimetres unless otherwise stated.

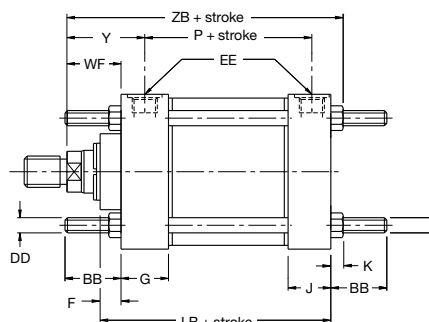

**Style TD**  
Tie Rods Extended Both Ends  
(NFFA MX1)

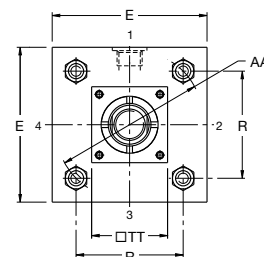

See Notes 1, 2, 3

**Notes**

- 1 All tie rod threads are UNF.
- 2 For Styles TB and TC an additional set of mounting nuts are supplied. For Style TD, two additional sets of mounting nuts are supplied.
- 3 R1 size BSPP ports to ISO 228/1 are supplied as standard on 2A cylinders. For smaller R2 size ports, please see page 42.

**Dimensions TB, TC & TD Continued**

Bore Ø	Rod No.	K	R	TT	WF	Y	+ stroke							
							LB	P	ZB max					
203.2 (8")	1	16.0	163.6	101.6	41.3	68	149.2	86	187.4					
	2			177.8	57.2	84			203.3					
	3			101.6	47.6	74			193.8					
	4			101.6	50.8	78			197.0					
	5			101.6	57.2	84			203.3					
	6			139.7	57.2	84			203.3					
	7			139.7	57.2	84			203.3					
	8			139.7	57.2	84			203.3					
	0			177.8	57.2	84			203.3					
254.0 (10")	1	17.0	201.2	101.6	47.6	77	181.0	107	226.5					
	3			101.6	50.8	80			229.7					
	4			101.6	57.2	86			236.0					
	5			139.7	57.2	86			236.0					
	6			139.7	57.2	86			236.0					
	7			139.7	57.2	86			236.0					
	9			177.8	57.2	86			236.0					
	0			177.8	57.2	86			236.0					
	304.8 (12")			1	17.0	238.8			101.6	50.8	80	193.7	120	242.4
3		101.6	57.2	86			248.7							
4		139.7	57.2	86			248.7							
5		139.7	57.2	86			248.7							
6		139.7	57.2	86			248.7							
8		177.8	57.2	86			248.7							
9		177.8	57.2	86			248.7							
355.6 (14")		1	19.0	276.9			101.6	57.2	94	225.4	142			282.6
		3					139.7	57.2	94					282.6
	4	139.7			57.2	94	282.6							
	5	139.7			57.2	94	282.6							
	7	177.8			57.2	94	282.6							
	8	177.8			57.2	94	282.6							

All dimensions are in millimetres unless otherwise stated.



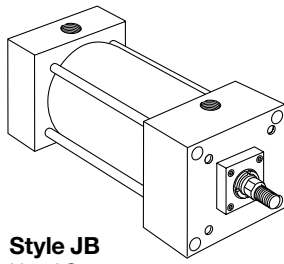

**Style JB**  
Head Square  
(NFA Style ME3)

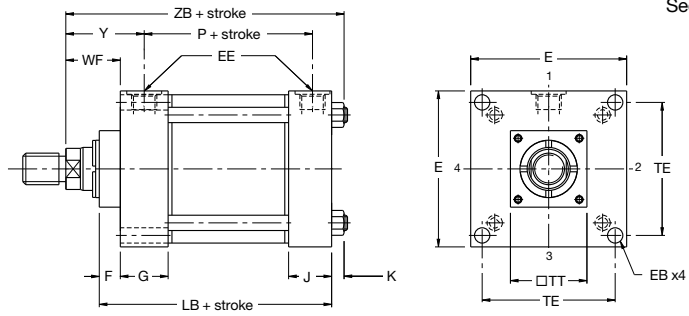

See Note 2

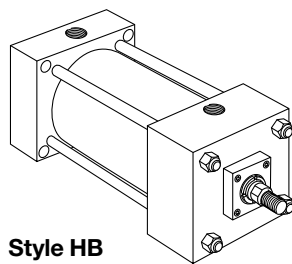

**Style HB**  
Cap Square  
(NFA Style ME4)

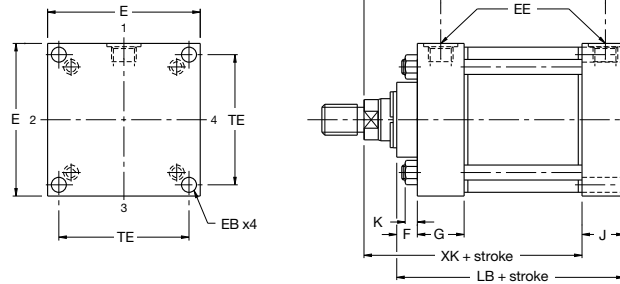

See Note 2

**Dimensions JB, HB & BB** See also Rod End Dimensions, page 30

Bore Ø	Rod No.	CB	CD <sup>+0.00</sup> <sub>-0.08</sub>	CW	E	EB	EE <sup>2</sup> (BSPP)	F	G	J	K	L	LR													
203.2 (8")	1	39.7	25.43	19.1	215.9	18	G <sup>3</sup> / <sub>4</sub>	19.1	50.8	38.1	16.0	38.1	31.8													
	2																									
	3																									
	4																									
	5																									
	6																									
	7																									
	8																									
	0																									
	254.0 (10")													1	52.4	34.95	25.4	269.9	22	G1	19.1	57.2	50.8	17.0	54.0	47.6
3																										
4																										
5																										
6																										
7																										
9																										
0																										
304.8 (12")		1	65.1	44.48	31.8	323.9	22	G1	19.1	57.2	50.8	17.0	57.2	54.0												
		3																								
	4																									
	5																									
	6																									
	8																									
	9																									
	355.6 (14")	1													65.1	50.83	31.8	374.7	24	G1 <sup>1</sup> / <sub>4</sub>	19.1	69.9	57.2	19.0	63.5	60.3
		3																								
		4																								
5																										
7																										
8																										

All dimensions are in millimetres unless otherwise stated.



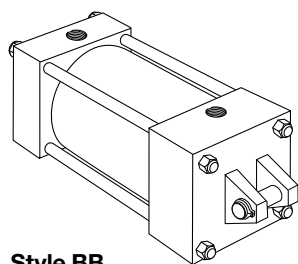

**Style BB**  
Cap Fixed Clevis  
(NFA Style MP1)

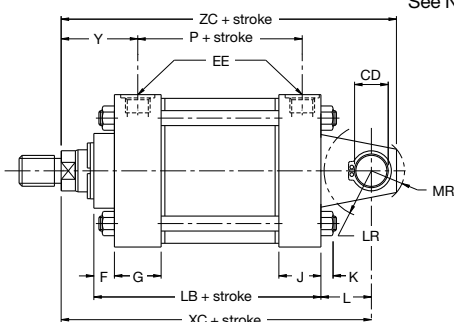
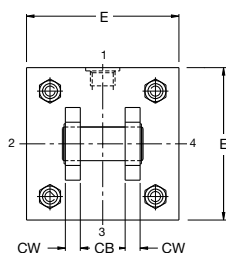

See Note 1, 2

**Notes**

- Supplied complete with pivot pin.
- R1 size BSPP ports to ISO 228/1 are supplied as standard on 2A cylinders. For smaller R2 size ports, please see page 42.

**Dimensions JB, HB & BB Continued**

Bore Ø	Rod No.	MR	TE	TT	WF	Y	+ stroke											
							LB	P	XC	XK	ZB max	ZC	ZJ					
203.2 (8")	1	30.2	192.3	101.6	41.3	68	149.2	86	209.6	133.4	187.4	235.0	171.5					
	2			177.8	57.2	84			225.4	149.2	203.3	250.8	187.3					
	3			101.6	47.6	74			215.9	139.7	193.8	241.3	177.8					
	4			101.6	50.8	78			219.1	142.9	197.0	244.5	181.0					
	5			101.6	57.2	84			225.4	149.2	203.3	250.8	187.3					
	6			139.7	57.2	84			225.4	149.2	203.3	250.8	187.3					
	7			139.7	57.2	84			225.4	149.2	203.3	250.8	187.3					
	8			139.7	57.2	84			225.4	149.2	203.3	250.8	187.3					
	0			177.8	57.2	84			225.4	149.2	203.3	250.8	187.3					
254.0 (10")	1	41.3	238.8	101.6	47.6	77	181.0	107	263.5	158.8	226.5	298.5	209.6					
	3			101.6	50.8	80			266.7	161.9	229.7	301.6	212.7					
	4			101.6	57.2	86			273.1	168.3	236.0	308.0	219.1					
	5			139.7	57.2	86			273.1	168.3	236.0	308.0	219.1					
	6			139.7	57.2	86			273.1	168.3	236.0	308.0	219.1					
	7			139.7	57.2	86			273.1	168.3	236.0	308.0	219.1					
	9			177.8	57.2	86			273.1	168.3	236.0	308.0	219.1					
	0			177.8	57.2	86			273.1	168.3	236.0	308.0	219.1					
	304.8 (12")			1	54.0	281.9			101.6	50.8	80	193.7	120	282.6	174.6	242.4	327.0	225.4
3		101.6	57.2	86			288.9	181.0	248.7	333.4	231.8							
4		139.7	57.2	86			288.9	181.0	248.7	333.4	231.8							
5		139.7	57.2	86			288.9	181.0	248.7	333.4	231.8							
6		139.7	57.2	86			288.9	181.0	248.7	333.4	231.8							
8		177.8	57.2	86			288.9	181.0	248.7	333.4	231.8							
9		177.8	57.2	86			288.9	181.0	248.7	333.4	231.8							
355.6 (14")		1	60.3	326.9			101.6	57.2	94	225.4	142			327.0	206.4	282.6	377.8	263.5
		3					139.7	57.2	94					327.0	206.4	282.6	377.8	263.5
	4	139.7			57.2	94	327.0	206.4	282.6			377.8	263.5					
	5	139.7			57.2	94	327.0	206.4	282.6			377.8	263.5					
	7	177.8			57.2	94	327.0	206.4	282.6			377.8	263.5					
	8	177.8			57.2	94	327.0	206.4	282.6			377.8	263.5					

All dimensions are in millimetres unless otherwise stated.



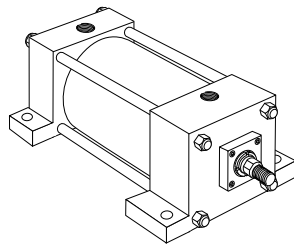

**Style C**  
Side Lug Mounting  
(NFFPA Style MS2)

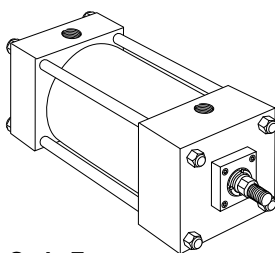
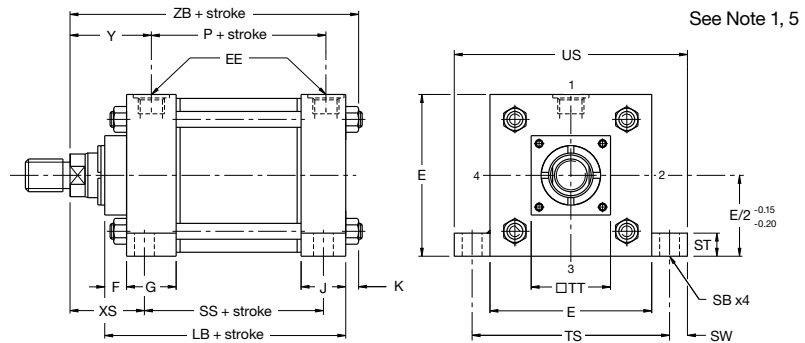

**Style F**  
Side Tapped Mounting  
(NFFPA Style MS4)

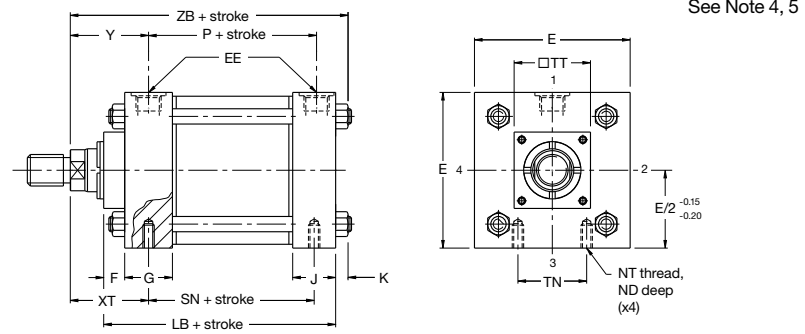

**Dimensions C, F & G** See also Rod End Dimensions, page 30

Bore Ø	Rod No.	E	EB	EE <sup>5</sup> (BSPP)	EL	EO	ES	ET	F	G	J	K	ND	NT <sup>4</sup>	R	SB <sup>1</sup>	ST																	
203.2 (8")	1	215.9	18	G <sup>3</sup> / <sub>4</sub>	28.6	15.9	57.2	50.8	19.1	50.8	38.1	16.0	28.6	M20	163.6	22	25.4																	
	2																																	
	3																																	
	4																																	
	5																																	
	6																																	
	7																																	
	8																																	
	0																																	
254.0 (10")	1	269.9	22	G1	33.3	15.9	69.9	61.9	19.1	57.2	50.8	17.0	38.1	M24	201.2	26	31.8																	
	3																																	
	4																																	
	5																																	
	6																																	
	7																																	
	9																																	
	0																																	
	304.8 (12")																	1	323.9	22	G1	33.3	15.9	88.9	69.9	19.1	57.2	50.8	17.0	38.1	M24	238.8	26	31.8
3																																		
4																																		
5																																		
6																																		
8																																		
9																																		
355.6 (14")		1	374.7	24	G1 <sup>1</sup> / <sub>4</sub>	38.1	19.1	101.6	95.3	19.1	69.9	57.2	19.0	47.6	M30	276.9	33	38.1																
		3																																
	4																																	
	5																																	
	7																																	
	8																																	

All dimensions are in millimetres unless otherwise stated.



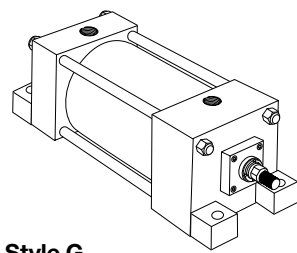

**Style G**  
Side End Lugs  
(NFA Style MS7)

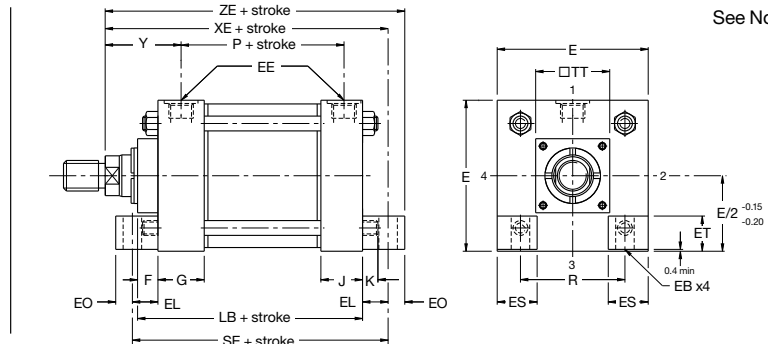

See Note 2, 3, 5

**Notes**

- Upper surfaces of lugs are machined for socket head screws.
- Mounting style G is not available on 203.2mm (8") bores with rod numbers 2, 6, 7, 8 and 0, and 254.0mm (10") bores with rod numbers 9 and 0.
- When using mounting Style G, check clearance between mounting members and rod attachment or accessory. If necessary, specify longer rod extension to avoid interference with mounting member.
- Tapped mounting holes are metric (coarse pitch series).
- R1 size BSPP ports to ISO 228/1 are supplied as standard on 2A cylinders. For smaller R2 size ports, please see page 42.

**Dimensions C, F & G Continued**

Bore Ø	Rod No.	SW	TN	TS	TT	US	XS	XT	Y	+ stroke							
										LB	P	SE	SN	SS	XE	ZB max	ZE
203.2 (8")	1	17.5	114.3	250.8	101.6	285.8	58.7	71.4	68	149.2	86	187.3	82.6	95.3	200.0	187.4	215.9
	2				177.8		74.6	87.3	84						-	203.3	-
	3				101.6		65.1	77.8	74						206.4	193.8	222.3
	4				101.6		68.3	81.0	78						209.6	197.0	225.4
	5				101.6		74.6	87.3	84						215.9	203.3	231.8
	6				139.7		74.6	87.3	84						-	203.3	-
	7				139.7		74.6	87.3	84						-	203.3	-
	8				139.7		74.6	87.3	84						-	203.3	-
254.0 (10")	1	22.2	139.7	314.3	101.6	358.8	69.9	79.4	77	181.0	107	228.6	104.8	117.5	242.9	226.5	258.8
	3				101.6		73.0	82.6	80						246.1	229.7	261.9
	4				101.6		79.4	88.9	86						252.4	236.0	268.3
	5				139.7		79.4	88.9	86						252.4	236.0	268.3
	6				139.7		79.4	88.9	86						252.4	236.0	268.3
	7				139.7		79.4	88.9	86						252.4	236.0	268.3
	9				177.8		79.4	88.9	86						-	236.0	-
	0				177.8		79.4	88.9	86						-	236.0	-
304.8 (12")	1	22.2	184.2	368.0	101.6	412.8	73.0	82.6	80	193.7	120	241.3	117.5	130.2	258.8	242.4	274.6
	3				101.6		79.4	88.9	86						265.1	248.7	281.0
	4				139.7		79.4	88.9	86						265.1	248.7	281.0
	5				139.7		79.4	88.9	86						265.1	248.7	281.0
	6				139.7		79.4	88.9	86						265.1	248.7	281.0
	8				177.8		79.4	88.9	86						265.1	248.7	281.0
	9				177.8		79.4	88.9	86						265.1	248.7	281.0
	355.6 (14")				1		28.6	212.7	431.8						101.6	489.0	85.7
3		139.7	85.7	96.8	94	301.6				282.6	320.7						
4		139.7	85.7	96.8	94	301.6				282.6	320.7						
5		139.7	85.7	96.8	94	301.6				282.6	320.7						
7		177.8	85.7	96.8	94	301.6				282.6	320.7						
8		177.8	85.7	96.8	94	301.6				282.6	320.7						

All dimensions are in millimetres unless otherwise stated.



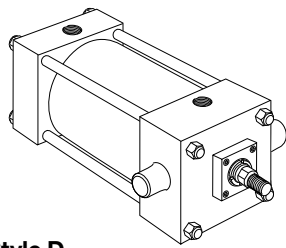

**Style D**  
Head Trunnion  
(NFPA Style MT1)

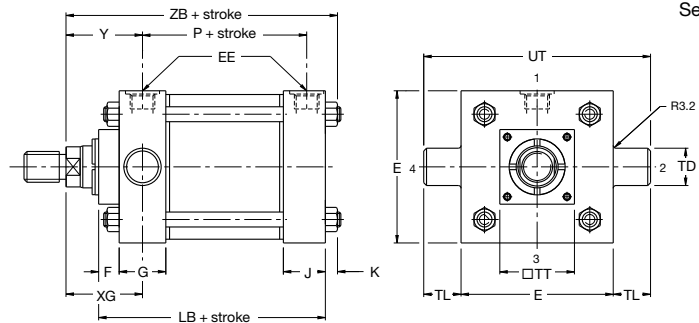

See Note 2

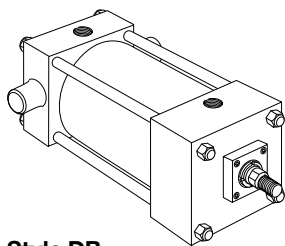

**Style DB**  
Cap Trunnion  
(NFPA Style MT2)

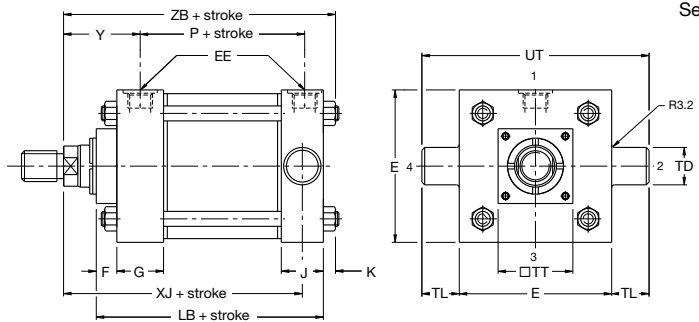

See Note 2

**Dimensions D, DB & DD** See also Rod End Dimensions, page 30

Bore Ø	Rod No.	BD	E	EE <sup>2</sup> (BSPP)	F	G	J	K	TD <sup>+0.00</sup> <sub>-0.03</sub>	TL	TM	TT											
203.2 (8")	1	63.5	215.9	G <sup>3</sup> / <sub>4</sub>	19.1	50.8	38.1	16.0	34.93	34.9	247.7	101.6											
	2											177.8											
	3											101.6											
	4											101.6											
	5											101.6											
	6											139.7											
	7											139.7											
	8											139.7											
	0											177.8											
254.0 (10")	1	76.2	269.9	G1	19.1	57.2	50.8	17.0	44.45	44.5	304.8	101.6											
	3											101.6											
	4											101.6											
	5											139.7											
	6											139.7											
	7											139.7											
	9											177.8											
	0											177.8											
	304.8 (12")											1	76.2	323.9	G1	19.1	57.2	50.8	17.0	44.45	44.5	355.6	101.6
3		101.6																					
4		139.7																					
5		139.7																					
6		139.7																					
8		177.8																					
9		177.8																					
355.6 (14")		1	88.9	374.7	G1 <sup>1</sup> / <sub>4</sub>	19.1	69.9	57.2	19.0	50.83	50.8	412.8											101.6
		3																					139.7
	4	139.7																					
	5	139.7																					
	7	177.8																					
	8	177.8																					

All dimensions are in millimetres unless otherwise stated.



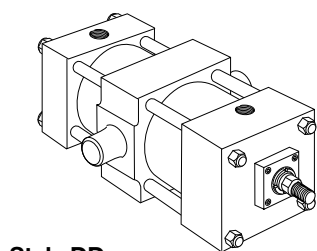

**Style DD**  
Intermediate Fixed Trunnion  
(NFPA Style MT4)

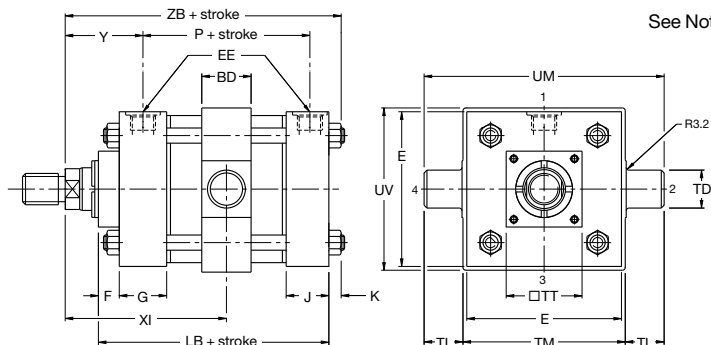

See Notes 1, 2

**Notes**

- 1 XI dimension to be specified by customer. Please note minimum dimension from the table below.
- 2 R1 size BSPP ports to ISO 228/1 are supplied as standard on 2A cylinders. For smaller R2 size ports, please see page 42.

**Dimensions D, DB & DD Continued**

Bore Ø	Rod No.	UM	UT	UV	XG	Min. XI <sup>1</sup>	Y	Style DD min. stroke	+ stroke			
									LB	P	XJ	ZB max
203.2 (8")	1	317.5	285.8	241.3	66.7	123.8	68	22.2	149.2	86	152.4	187.4
	2				82.6	139.7	84				168.3	203.3
	3				73.0	130.2	74				158.8	193.8
	4				76.2	133.4	78				161.9	197.0
	5				82.6	139.7	84				168.3	203.3
	6				82.6	139.7	84				168.3	203.3
	7				82.6	139.7	84				168.3	203.3
	8				82.6	139.7	84				168.3	203.3
254.0 (10")	1	393.7	358.8	298.5	76.2	142.9	77	22.2	181.0	107	184.2	226.5
	3				79.4	146.1	80				187.3	229.7
	4				85.7	152.4	86				193.7	236.0
	5				85.7	152.4	86				193.7	236.0
	6				85.7	152.4	86				193.7	236.0
	7				85.7	152.4	86				193.7	236.0
	9				85.7	152.4	86				193.7	236.0
	0				85.7	152.4	86				193.7	236.0
304.8 (12")	1	444.5	412.8	349.3	79.4	146.1	80	9.5	193.7	120	200.0	242.4
	3				85.7	152.4	86				206.4	248.7
	4				85.7	152.4	86				206.4	248.7
	5				85.7	152.4	86				206.4	248.7
	6				85.7	152.4	86				206.4	248.7
	8				85.7	152.4	86				206.4	248.7
	9				85.7	152.4	86				206.4	248.7
	355.6 (14")				1	514.4	476.2				406.4	92.1
3		92.1	171.5	94	235.0			282.6				
4		92.1	171.5	94	235.0			282.6				
5		92.1	171.5	94	235.0			282.6				
7		92.1	171.5	94	235.0			282.6				
8		92.1	171.5	94	235.0			282.6				

All dimensions are in millimetres unless otherwise stated.



**Rod End Details – 203.2mm to 355.6mm  
(8" to 14") bore sizes**

Piston Rod End Data for 25.4mm to 152.4mm (1" to 6") bore size cylinders is shown on page 20.

**Rod End Style 4**

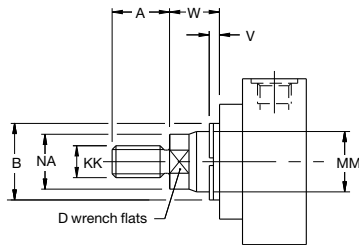

**Rod End Style 8**

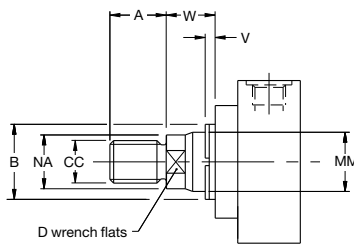

**Rod End Style 9**

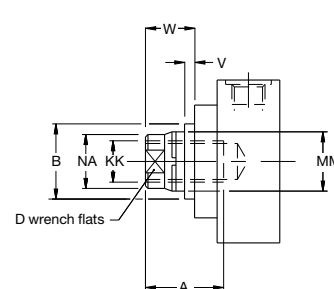

**Rod End Styles 4 & 8**

Style 4 rod ends are recommended for all applications in which the work piece is secured against the rod shoulder. Where the work piece is not shouldered, Style 8 rod ends are recommended. If rod end style is not specified, Style 4 will be supplied.

**Rod End Style 9**

For applications where a female thread is required.

**Rod End Style 3**

Non-standard piston rod ends are designated 'Style 3'. A dimensional sketch or description should accompany the order. Please specify dimensions KK or CC, and A.

**Rod End Dimensions – 203.2mm to 355.6mm (8" to 14") bore sizes**

Bore Ø	Rod No.	MM Rod Diameter	Styles 4 & 9		Style 8		A	B <sup>+0.00</sup> <sub>-0.05</sub>	D	NA	V	W	
			KK Metric	KK UNF <sup>1</sup>	CC Metric	CC UNF							
203.2 (8")	1	34.9 (1 3/8")	M26x1.5	1-14	M30x2	1 1/4-12	41.3	50.77	30	33.3	6.4	22.2	
	2	139.7 (5 1/2")	M100x2	4-12	M130x2	5 1/4-12	139.7	158.72	120	136.5	12.7	38.1	
	3	44.5 (1 3/4")	M33x2	1 1/4-12	M39x2	1 1/2-12	50.8	60.30	36	42.9	9.5	28.6	
	4	50.8 (2")	M39x2	1 1/2-12	M45x2	1 3/4-12	57.2	66.65	41	49.2	9.5	31.8	
	5	63.5 (2 1/2")	M48x2	1 1/2-12	M56x2	2 1/4-12	76.2	79.35	55	60.3	12.7	38.1	
	6	76.2 (3")	M58x2	2 1/4-12	M68x2	2 3/4-12	88.9	95.22	65	73.0	12.7	38.1	
	7	88.9 (3 1/2")	M64x2	2 1/2-12	M76x2	3 1/4-12	88.9	107.92	75	85.7	12.7	38.1	
	8	101.6 (4")	M76x2	3-12	M95x2	3 3/4-12	101.6	120.62	85	98.4	12.7	38.1	
	0	127.0 (5")	M90x2	3 1/2-12	M110x2	4 3/4-12	127.0	146.02	110	123.8	12.7	38.1	
254.0 (10")	1	44.5 (1 3/4")	M33x2	1 1/4-12	M39x2	1 1/2-12	50.8	60.30	36	42.9	9.5	28.6	
	3	50.8 (2")	M39x2	1 1/2-12	M45x2	1 3/4-12	57.2	66.65	41	49.2	9.5	31.8	
	4	63.5 (2 1/2")	M48x2	1 1/2-12	M56x2	2 1/4-12	76.2	79.35	55	60.3	12.7	38.1	
	5	76.2 (3")	M58x2	2 1/4-12	M68x2	2 3/4-12	88.9	95.22	65	73.0	12.7	38.1	
	6	88.9 (3 1/2")	M64x2	2 1/2-12	M76x2	3 1/4-12	88.9	107.92	75	85.7	12.7	38.1	
	7	101.6 (4")	M76x2	3-12	M95x2	3 3/4-12	101.6	120.62	85	98.4	12.7	38.1	
	9	127.0 (5")	M90x2	3 1/2-12	M110x2	4 3/4-12	127.0	146.02	110	123.8	12.7	38.1	
	0	139.7 (5 1/2")	M100x2	4-12	M130x2	5 1/4-12	139.7	158.72	120	136.5	12.7	38.1	
	304.8 (12")	1	50.8 (2")	M39x2	1 1/2-12	M45x2	1 3/4-12	57.2	66.65	41	49.2	9.5	31.8
3		63.5 (2 1/2")	M48x2	1 1/2-12	M56x2	2 1/4-12	76.2	79.35	55	60.3	12.7	38.1	
4		76.2 (3")	M58x2	2 1/4-12	M68x2	2 3/4-12	88.9	95.22	65	73.0	12.7	38.1	
5		88.9 (3 1/2")	M64x2	2 1/2-12	M76x2	3 1/4-12	88.9	107.92	75	85.7	12.7	38.1	
6		101.6 (4")	M76x2	3-12	M95x2	3 3/4-12	101.6	120.62	85	98.4	12.7	38.1	
8		127.0 (5")	M90x2	3 1/2-12	M110x2	4 3/4-12	127.0	146.02	110	123.8	12.7	38.1	
9		139.7 (5 1/2")	M100x2	4-12	M130x2	5 1/4-12	139.7	158.72	120	136.5	12.7	38.1	
355.6 (14")		1	63.5 (2 1/2")	M48x2	1 1/2-12	M56x2	2 1/4-12	76.2	79.35	55	60.3	12.7	38.1
		3	76.2 (3")	M58x2	2 1/4-12	M68x2	2 3/4-12	88.9	95.22	65	73.0	12.7	38.1
	4	88.9 (3 1/2")	M64x2	2 1/2-12	M76x2	3 1/4-12	88.9	107.92	75	85.7	12.7	38.1	
	5	101.6 (4")	M76x2	3-12	M95x2	3 3/4-12	101.6	120.62	85	98.4	12.7	38.1	
	7	127.0 (5")	M90x2	3 1/2-12	M110x2	4 3/4-12	127.0	146.02	110	123.8	12.7	38.1	
	8	139.7 (5 1/2")	M100x2	4-12	M130x2	5 1/4-12	139.7	158.72	120	136.5	12.7	38.1	

<sup>1</sup> All rod threads are UNF except 1-14 which is UNS.

All dimensions are in millimetres unless otherwise stated.



### Accessory Selection

Accessories for the rod end of a cylinder are selected by reference to the rod end thread, shown on pages 20 and 30, while the same accessories, when used at the cap end, are selected by cylinder bore size. See tables of part numbers below and on the following pages.

#### Pivot Pin Diameters – Style BB

To obtain the same diameter of pivot pin at the rod end and cap end of a style BB clevis-mounted cylinder fitted with a rod clevis or plain rod eye, a no. 1 rod should be specified.

### Rod and Cap End Accessories

Accessories for the 2A cylinder comprise:

- Rod End** – rod clevis, eye bracket and pivot pin  
 – plain rod eye, clevis bracket and pivot pin

- Cap End** – eye bracket for style BB mounting

#### Rod Clevis, Eye Bracket and Pivot Pin

Thread KK	Rod Clevis	Eye Bracket	Pivot Pin	Nominal Force kN	Mass kg
M8x1.25	51221G	74077	–	7.7	0.4
M10x1.5	50940G	69195	68368	18.3	0.7
M12x1.5	50941G	69195	68368	18.3	0.7
M20x1.5	50942G	69196	68369	46.8	2.3
M22x1.5	50943G	85361 <sup>1</sup>	68370	83.8	5.2
M26x1.5	50944G	85361 <sup>1</sup>	68370	91.0	5.1
M33x2	50945G	69198	68371	94.5	9.9
M39x2	50946G	85362 <sup>1</sup>	68372	203.3	19.5
M45x2	50947G	85363 <sup>1</sup>	68373	312.1	28.6
M48x2	50948G	85363 <sup>1</sup>	68373	312.1	28.5
M58x2	50949G	85364 <sup>1</sup>	68374	420.0	48.4
M64x2	50950G	85365 <sup>1</sup>	68375	420.0	63.4
M68x2	50951G	85365 <sup>1</sup>	68375	543.6	63.1
M76x2	50952G	73538	73545	256.0	104.8
M90x2	50953G	73539	73547	334.4	157.8
M100x2	50954G	73539	73547	334.4	156.6
M110x2	–	–	–	–	–

#### Plain Rod Eye, Clevis Bracket and Pivot Pin

Thread KK	Plain Rod Eye	Clevis Bracket	Pivot Pin	Nominal Force kN	Mass kg
M8x1.25	74075G	74076	74078	15.0	0.5
M10x1.5	69089G	69205	68368	22.3	1.3
M12x1.5	69090G	69205	68368	25.4	1.3
M20x1.5	69091G	69206	68369	54.0	3.2
M22x1.5	69092G	69207	68370	58.0	6.6
M26x1.5	69093G	69207	68370	85.6	6.6
M33x2	69094G	69208	68371	149.4	12.7
M39x2	69095G	69209	68372	151.6	23.4
M45x2	69096G	69210	69215	147.2	41.1
M48x2	69097G	69210	69215	147.2	41.5
M58x2	69098G	69211	68374	155.6	51.2
M64x2	69099G	69212	68375	150.7	65.2
M68x2	69100G	69213	69216	164.6	69.5
M76x2	73536G	73542	73545	372.3	126.7
M90x2	73437G	73542	73545	372.3	124.0
M100x2	73438G	73543	82181	457.5	180.7
M110x2	73439G	73544	73547	483.4	173.5

#### Cap End Eye Bracket for Styles BB and BC Cylinders

Bore Ø	Eye Bracket Part Number	Nominal Force kN	Mass kg
25.4 (1")	74076 <sup>2</sup>	16.0	0.4
38.1 (1½")	69195	18.3	0.4
50.8 (2")	69195	18.3	0.4
63.5 (2½")	69195	18.3	0.4
82.6 (3¼")	69196	46.8	1.5
101.6 (4")	69196	46.8	1.5
127.0 (5")	69196	46.8	1.5
152.4 (6")	85361 <sup>1</sup>	91.0	3.4
203.2 (8")	85361 <sup>1</sup>	91.0	3.4
254.0 (10")	69198	94.5	5.6
304.8 (12")	85362 <sup>1</sup>	220.6	11.1
355.6 (14")	85363 <sup>1</sup>	312.1	17.0

All dimensions are in millimetres unless otherwise stated.

<sup>1</sup> Cylinder accessory dimensions conform to NFPA recommended standard, NFPA/T3.6.8.R1 - 1984

<sup>2</sup> Mounting plate for 25.4mm (1") bore single tang BB and BC mounting styles is Clevis Bracket 74076

**Rod Clevis, Eye Bracket and Pivot Pin**
**Rod Clevis Dimensions**

Part Number	A	CB	CD <sup>+0.10</sup> / <sub>+0.05</sub>	CE	CW	ER	KK	Nominal Force kN	Mass kg
51221G <sup>1</sup>	20.6	8.8	7.90	57.2	5.2	7.5	M8x1.25	11.6	0.1
50940G	19.1	19.8	12.70	38.1	12.7	12.7	M10x1.5	18.9	0.2
50941G	19.1	19.8	12.70	38.1	12.7	12.7	M12x1.5	21.9	0.2
50942G	28.6	32.6	19.05	54.0	15.9	19.1	M20x1.5	49.9	0.6
50943G	41.3	38.9	25.40	74.6	19.1	25.4	M22x1.5	83.8	1.3
50944G	41.3	38.9	25.40	74.6	19.1	25.4	M26x1.5	96.7	1.3
50945G	50.8	51.6	34.93	95.3	25.4	34.9	M33x2	149.4	3.1
50946G	57.2	64.7	44.45	114.3	31.8	44.5	M39x2	203.3	6.0
50947G	76.2	64.7	50.80	139.7	31.8	50.8	M45x2	317.9	8.4
50948G	76.2	64.7	50.80	139.7	31.8	50.8	M48x2	341.6	8.3
50949G	88.9	77.4	63.50	165.1	38.1	63.5	M58x2	480.2	15.1
50950G	88.9	77.4	76.20	171.5	38.1	69.9	M64x2	535.1	19.0
50951G	88.9	77.4	76.20	171.5	38.1	69.9	M68x2	589.9	18.7
50952G	88.9	102.8	88.90	196.9	50.8	88.9	M76x2	1048.8	34.1
50953G	101.6	116.0	101.60	223.8	57.2	101.6	M90x2	1292.2	49.8
50954G	101.6	116.0	101.60	223.8	57.2	101.6	M100x2	1480.0	48.6

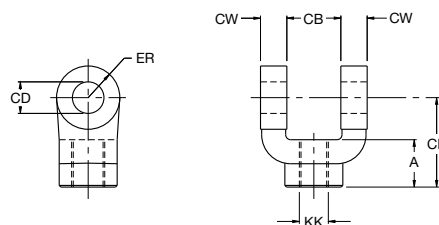
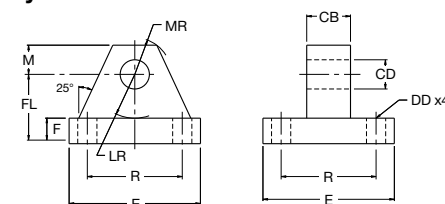
**Rod Clevis (Female Clevis)**

**Eye Bracket**

**Eye Bracket Dimensions**

Part Number	CB	CD <sup>+0.10</sup> / <sub>+0.05</sub>	DD	E	F	FL	LR	M	MR	R	Nominal Force kN	Mass kg
74077	7.9	7.90	6.8	57.2	9.5	25.4	15.9	9.5	12.7	44.5	7.6	0.3
69195	19.1	12.70	10.3	63.5	9.5	28.6	19.1	12.7	14.3	41.4	18.3	0.4
69196	31.8	19.05	13.5	88.9	15.9	47.6	31.8	19.1	22.2	64.8	46.8	1.5
85361 <sup>2</sup>	38.1	25.40	16.7	114.3	22.2	60.3	38.1	25.4	31.8	82.6	91.0	3.4
69198	50.8	34.93	16.7	127.0	22.2	76.2	54.0	34.9	41.3	97.0	94.5	5.6
85362 <sup>2</sup>	63.5	44.45	23.0	165.1	28.6	85.7	57.2	44.5	54.0	125.7	220.6	11.1
85363 <sup>2</sup>	63.5	50.80	27.0	190.5	38.1	101.6	63.5	50.8	61.9	145.5	312.1	17.0
85364 <sup>2</sup>	76.2	63.50	30.2	215.9	44.5	120.6	76.2	63.5	76.2	167.1	420.0	27.4
85365 <sup>2</sup>	76.2	76.20	33.3	241.3	50.8	133.3	82.6	69.9	82.6	190.5	543.6	35.8
73538	101.6	88.90	46.0	320.7	42.9	144.5	101.6	88.9	95.3	244.3	256.0	55.6
73539	114.3	101.60	52.4	377.8	49.2	163.5	114.3	101.6	108.0	290.8	334.4	84.3

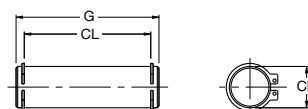
**Pivot Pin for Clevis Bracket and Eye Bracket**

Part Number	CD <sup>+0.00</sup> / <sub>-0.05</sub>	CL <sup>+0.0</sup> / <sub>-0.5</sub>	G	Nominal Force kN	Mass kg
74078	11.10	32.7	40	29.4	0.03
68368	12.73	46.3	56	38.4	0.1
68369	19.08	65.4	75	86.1	0.2
68370	25.43	77.9	88	152.9	0.5
68371	34.95	103.4	115	289.8	1.2
68372	44.48	128.8	143	469.1	2.4
68373	50.83	129.7	145	612.7	3.2
69215	50.83	141.4	158	612.7	3.5
68374	63.53	155.1	171	957.4	5.9
68375	76.23	154.7	173	1378.7	8.6
69216	76.23	167.7	185	1378.7	9.2
73545	88.93	205.7	225	1876.8	15.2
82181	101.63	215.5	235	2522.9	22.4
73547	101.63	231.7	251	2522.9	23.5

**Pivot Pin for Clevis Bracket and Eye Bracket**

<sup>1</sup> Includes pivot pin

<sup>2</sup> Cylinder accessory dimensions conform to NFPA recommended standard, NFPA/T3.6.8.R1 - 1984

All dimensions are in millimetres unless otherwise stated.

**Plain Rod Eye and Clevis Bracket**
**Plain Rod Eye Dimensions**

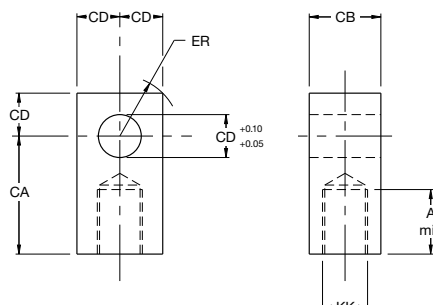
Part Number	A min.	CA	CB	CD <sup>+0.10</sup> <sub>+0.05</sub>	ER	KK	Nominal Force kN	Mass kg
74075G	19.1	38.1	11.1	11.10	15.2	M8x1.25	14.7	0.1
69089G	19.1	38.1	19.1	12.70	18.3	M10x1.5	22.3	0.2
69090G	19.1	38.1	19.1	12.70	18.3	M12x1.5	25.4	0.2
69091G	28.6	52.4	31.8	19.05	27.0	M20x1.5	54.0	0.5
69092G	28.6	60.3	38.1	25.40	36.5	M22x1.5	58.0	1.1
69093G	41.3	71.4	38.1	25.40	36.5	M26x1.5	96.8	1.1
69094G	50.8	87.3	50.8	34.93	50.0	M33x2	149.4	2.6
69095G	57.2	101.6	63.5	44.45	63.5	M39x2	200.6	5.1
69096G	57.2	111.1	63.5	50.80	72.2	M45x2	238.6	6.4
69097G	76.2	127.0	63.5	50.80	72.2	M48x2	334.4	6.8
69098G	88.9	147.6	76.2	63.50	90.5	M58x2	440.1	12.1
69099G	88.9	155.6	76.2	76.20	108.0	M64x2	490.5	16.0
69100G	92.1	165.1	88.9	76.20	108.0	M68x2	549.8	19.6
73536G	101.6	193.7	101.6	88.90	126.2	M76x2	719.3	31.1
73437G	127.0	193.7	101.6	88.90	126.2	M90x2	969.0	28.4
73438G	139.7	231.8	114.3	101.60	144.5	M100x2	1220.9	42.5
73439G	139.7	231.8	127.0	101.60	144.5	M110x2	1375.6	48.4

**Plain Rod Eye**

**Clevis Bracket Dimensions**

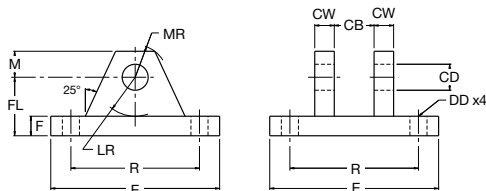
Part Numbers	CB	CD <sup>+0.10</sup> <sub>+0.05</sub>	CW	DD	E	F	FL	LR	M	MR	R	Nominal Force kN	Mass kg
74076	12.0	11.10	9.5	6.8	57.2	9.5	25.4	15.9	9.5	12.7	44.5	16.0	0.4
69205	19.8	12.70	12.7	10.3	88.9	12.7	38.1	19.1	12.7	15.9	64.8	32.6	1.0
69206	32.6	19.05	15.9	13.5	127.0	15.9	47.6	30.2	19.1	23.0	97.0	62.4	2.5
69207	38.9	25.40	19.1	16.7	165.1	19.1	57.2	38.1	25.4	31.8	125.7	85.6	5.0
69208	51.6	34.93	25.4	16.7	190.5	22.2	76.2	50.8	34.9	42.1	145.5	164.6	8.8
69209	64.7	44.45	31.8	23.0	241.3	22.2	92.1	69.9	44.5	56.4	190.5	151.6	15.9
69210	64.7	50.80	38.1	27.0	323.9	25.4	108.0	81.0	57.2	70.6	238.8	147.2	31.2
69211	77.4	63.50	38.1	30.2	323.9	25.4	114.3	88.9	63.5	79.4	238.8	155.6	33.2
69212	77.4	76.20	38.1	33.3	323.9	25.4	152.4	108.0	76.2	91.3	238.8	150.7	40.7
69213	90.1	76.20	38.1	33.3	323.9	25.4	152.4	108.0	76.2	91.3	238.8	164.6	40.7
73542	102.8	88.90	50.8	46.0	393.7	42.9	169.9	127.0	88.9	104.8	304.8	372.3	80.4
73543	116.0	101.60	50.8	52.4	444.5	49.2	195.3	146.1	101.6	123.8	349.3	457.5	115.8
73544	128.2	101.60	50.8	52.4	444.5	49.2	195.3	146.1	101.6	123.8	349.3	483.4	101.6

**Clevis Bracket**

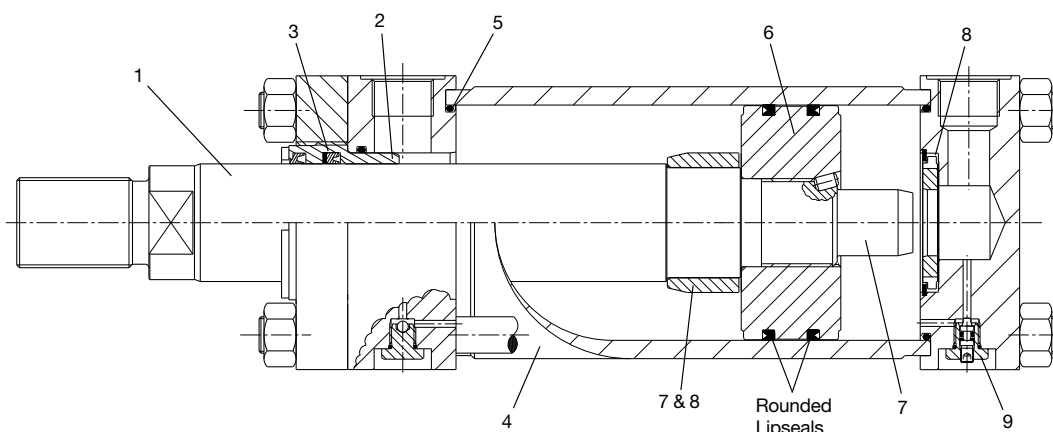
All dimensions are in millimetres unless otherwise stated.



### Series 2AN Non-Lubricated Air Cylinders

Increased market demand and Parker's continuous research and testing efforts inspired the development of the Series 2AN Non-Lubricated Air Cylinder, suitable for use with filtered air.

These cylinders are designed to operate in environments where it is not possible to add lubrication to the compressed air entering the cylinder. Certain packaging and assembly operations, food environments, and microprocessor chip manufacturing are typical examples of applications where the exhausting of oil into the environment is not desirable.

Available in bore sizes up to 304.8mm (12") diameter and rod diameters up to 63.5mm (2<sup>1</sup>/<sub>2</sub>"), the Series 2AN cylinder features rounded lip rod and piston seals.

#### Rounded Lipseal

The rounded sealing lip glides over lubricant film instead of scraping it off, and the increased heel thickness and outer lip extension improve stability and resist rolling. The use of the rounded lipseal reduces friction, increases life and eliminates the need for added lubrication.

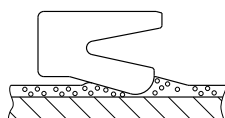

#### Design Features and Benefits

For the standard features shown above, please see pages 4 and 5. For available bore and rod sizes, please see table opposite.

Benefits of the 2AN Series cylinder include long seal and bearing life and, since no oil is added through the use of lubricators, no oil is expelled into the atmosphere with the exhaust air as the cylinder strokes. In addition, the use of non-lubricated air results in lower overall operating costs.

With the exception of fluorocarbon elastomer seals, and unless otherwise stated, all modifications available with Series 2A Cylinders are also available with Series 2AN cylinders.

#### Operating Temperatures

The temperature range for Series 2AN cylinders with Group 1 seals is -20°C to +80°C. Group 5, high temperature seals, are suitable for operating temperatures between -15°C and +150°C.

#### Ordering Information

To order a Non-Lubricated Air Cylinder, specify Series 2AN. See page 47 for the ordering code.

#### Available Bore and Rod Sizes

The following bore and rod sizes are available with Series 2AN cylinders. For all other sizes, please contact the factory.

Bore Ø	Rod Number	Rod Diameter MM
25.4 (1")	1	12.7 (1/2")
	2	15.9 (5/8")
38.1 (1 1/2")	1	15.9 (5/8")
	2	25.4 (1")
50.8 (2")	1	15.9 (5/8")
	2	34.9 (1 3/8")
	3	25.4 (1")
63.5 (2 1/2")	1	15.9 (5/8")
	2	44.5 (1 3/4")
	3	25.4 (1")
	4	34.9 (1 3/8")
82.6 (3 1/4")	1	25.4 (1")
	2	50.8 (2")
	3	34.9 (1 3/8")
	4	44.5 (1 3/4")
101.6 (4")	1	25.4 (1")
	2	63.5 (2 1/2")
	3	34.9 (1 3/8")
	4	44.5 (1 3/4")
	5	50.8 (2")
127.0 (5")	1	25.4 (1")
	3	34.9 (1 3/8")
	4	44.5 (1 3/4")
	5	50.8 (2")
	6	63.5 (2 1/2")
	152.4 (6")	1
3		44.5 (1 3/4")
4		50.8 (2")
5		63.5 (2 1/2")
203.2 (8")	1	34.9 (1 3/8")
	3	44.5 (1 3/4")
	4	50.8 (2")
	5	63.5 (2 1/2")
254.0 (10")	1	44.5 (1 3/4")
	3	50.8 (2")
	4	63.5 (2 1/2")
304.8 (12")	1	50.8 (2")
	3	63.5 (2 1/2")

## Replacement Parts for 2AN Cylinders

## Tie Rod Cylinders 2AN Series

### Service Assemblies and Seal Kits

Service Assembly Kits and Seal Kits for 2AN cylinders simplify the ordering and maintenance processes. This page lists only those kits specific to 2AN Series cylinders. For standard Series 2A cylinder service kits, please refer to page 45. They contain sub-assemblies which are ready for installation, and are supplied with full instructions. When ordering Service Assemblies and Seal Kits, please refer to the identification plate on the cylinder body and supply the following information:

**Serial Number - Bore - Stroke - Model Number - Fluid Type**

### Key to Part Numbers

(For all other part numbers, please refer to page 44).

- 14 Gland/bearing cartridge
- 17 Piston
- 40 Wiperseal – for gland
- 41 Rounded Lipseal – for gland
- 42 Rounded Lipseal – for piston
- 45 O-ring – gland/head

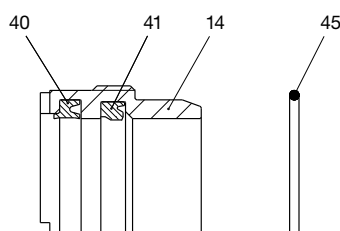

**2AN Gland Cartridge and Seals**

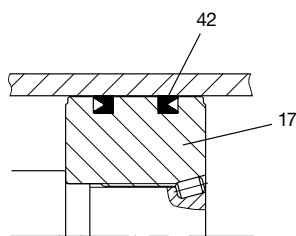

**Lipseal Piston**

### Seal Groups

Group 1 Seal Kits are supplied as standard. Special seals are available for 2AN Series cylinders in high temperature (Group 5) applications – please contact the factory for details.

### Ordering Information

To order a non-lubricated air cylinder, specify '2AN' in the order code on page 47.

### Contents and Part Numbers of 2AN Seal Kits for Pistons and Glands

(see key to part numbers opposite and on page 44)

#### Gland Cartridge Service Kit

Contains items 14, 40, 41, 45.

#### Gland Service Kit

Contains items 40, 41, 45.

Rod Diameter mm	Gland Cartridge Service Kit, Standard Seals	Gland Service Kit, Standard Seals
12.7 (1/2")	RG2AN00051	RK2AN00051
15.9 (5/8")	RG2AN00061	RK2AN00061
25.4 (1")	RG2AN00101	RK2AN00101
34.9 (1 3/8")	RG2AN00131	RK2AN00131
44.5 (1 3/4")	RG2AN00171	RK2AN00171
50.8 (2")	RG2AN00201	RK2AN00201
63.5 (2 1/2")	RG2AN00251	RK2AN00251

#### Piston Service Kit, Lipseal Piston

Contains two each of items 42 and 47.

Bore Ø	Piston Service Kit Lipseal Piston
25.4 (1")	PK1002AN01
38.1 (1 1/2")	PK1502AN01
50.8 (2")	PK2002AN01
63.5 (2 1/2")	PK2502AN01
82.6 (3 1/4")	PK3202AN01
101.6 (4")	PK4002AN01
127.0 (5")	PK5002AN01
152.4 (6")	PK6002AN01
203.2 (8")	PK8002AN01
254.0 (10")	PK9002AN01
304.8 (12")	PK9202AN01

### Tie Rod Torques

Please refer to the table on page 37.

### Repairs

Although 2AN cylinders are designed to make on-site maintenance or repairs as easy as possible, some operations can only be carried out in our factory. It is standard policy to fit a cylinder returned to the factory for repair with those replacement parts which are necessary to return it to 'as good as new' condition. Should the condition of the returned cylinder be such that repair would be uneconomical, you will be notified.

All dimensions are in millimetres unless otherwise stated.



### Mounting Styles

The notes which follow provide information for use in specific applications and should be read in conjunction with the information given on page 7.

### Extended Tie Rods

The standard tie rod extension for cylinders with mounting style TB, TC and TD is shown as BB in dimension tables. Longer or shorter extensions can be supplied.

Cylinders with extended tie rod mountings TB and TC are supplied with an additional set of mounting nuts of the appropriate grade for securing the cylinder to the machine member. For style TD, tie rods extended both ends, two additional sets of mounting nuts are supplied. In such applications one end is used for mounting and the opposite end to support the cylinder, or to attach other machine components.

Cylinders may be ordered with extended tie rods in addition to another mounting style. The extended tie rods may then be used for mounting other systems or machine components.

### Flange Mounted Cylinders

The diameter of the rod gland extension (B), pages 20 and 30, at the head end can be used as a pilot to locate the cylinders in relation to the machine. After alignment has been obtained, the flanges may be drilled for pins or dowels to prevent movement.

### Pivot Mountings

Pivot pins are supplied with style BB cap fixed clevis mounted cylinders and style BC cap detachable clevis mounted cylinders, with the exception of 1" bore sizes, which feature a single tang pivot – see page 16.

### Trunnion Mounted Cylinders

Trunnions require lubricated pillow blocks with minimum bearing clearances. Blocks should be aligned and mounted to eliminate bending moments on the trunnion pins. Self-aligning mounts must not be used to support the trunnions as bending forces can be set up.

An intermediate fixed trunnion mounting can be positioned to balance the weight of the cylinder, or it can be located at any point between the head or cap to suit the application. The position of the trunnion is fixed during manufacture and its location must be specified at the time of order.

### Foot Mounted Cylinders

Foot mounted cylinders should not be pinned or keyed at both ends. Changes in temperature and pressure under normal operating conditions cause the cylinder to increase (or decrease) from its installed length and it therefore must be free to expand and contract. It must not be pinned or keyed at both ends as advantages of cylinder elasticity in absorbing high shock loads would be lost.

### Foot Mountings and Thrust Keys

The turning moment which results from the application of force by a foot mounted cylinder must be resisted by secure mounting and effective guidance of the load. A thrust key modification is recommended to provide positive cylinder location.

Thrust key mountings eliminate the need for fitted bolts or external keys on Styles C, F and G side mounted cylinders. The gland retainer plate is extended below the nominal mounting surface to fit into a keyway milled into the mounting surface of the machine member. See 'Mounting Modifications' in the order code, page 47.

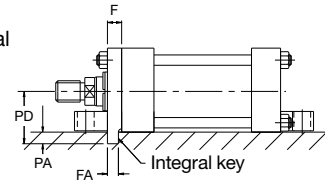

Bore Ø	F Nominal	FA <sup>+0.0</sup> / <sub>-0.075</sub>	PA <sup>+0.0</sup> / <sub>-0.2</sub>	PD
25.4 (1") <sup>1</sup>	9.5	8	4.9	23.8
38.1 (1½")	9.5	8	4.9	30.2
50.8 (2")	9.5	8	4.9	36.5
63.5 (2½")	9.5	8	4.9	42.9
82.6 (3¼")	15.9	14	8.1	55.6
101.6 (4")	15.9	14	8.1	65.1
127.0 (5")	15.9	14	8.1	77.8
152.4 (6")	19.1	18	9.5	92.1

<sup>1</sup> G mounting is not available with a thrust key on 25.4mm (1") bore cylinders.

### Tie Rod Supports

To increase the resistance to buckling of long stroke cylinders, tie rod supports may be fitted. These move the tie rods radially outwards and allow longer than normal strokes to be used without the need for an additional mounting.

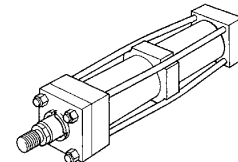

Bore Ø	Stroke (Metres)										Number of Supports Required
	1.5	1.8	2.1	2.4	2.7	3.0	3.3	3.6	3.9	4.2	
38.1 (1½")	1	1	1	2	2	2	3	3	3	4	
50.8 (2")	-	1	1	1	1	2	2	2	2	3	
63.5 (2½")	-	-	-	1	1	1	1	1	2	2	
82.6 (3¼")	-	-	-	-	-	1	1	1	1	1	
101.6 (4")	-	-	-	-	-	-	-	1	1	1	

Bore sizes above 101.6mm (4") do not require tie rod supports.

All dimensions are in millimetres unless otherwise stated.



### Stroke Tolerances

Stroke length tolerances are required due to the build-up of tolerances of piston, head, cap and cylinder body. Standard production stroke tolerances are  $-0.4$  to  $+0.8$ mm on all bore sizes and stroke lengths. For closer tolerances, please specify the required tolerance plus the operating temperature and pressure. Stroke tolerances of less than  $0.4$ mm are generally impracticable due to the elasticity of cylinders and, in these cases, the use of a stroke limiter should be considered – see page 43.

### Mounting Bolts

Parker recommends that mounting bolts with a minimum strength of ISO 898/1 grade 10.9 should be used for fixing cylinders to the machine or base. This recommendation is of particular importance where bolts are placed in tension or subjected to shear forces. Mounting bolts should be torque loaded to their manufacturer's recommended figures.

### Tie Rod Nuts

Tie rod mounting nuts, with lubricated threads, should be to a minimum strength of ISO 898/2 grade 10, torque loaded to the figures shown.

Bore Ø	Tie Rod Nut Torques	
	Nm min-max	lb.ft min-max
25.4 (1")	3 - 3.5	2 - 2.5
38.1 (1½")	8 - 9	5 - 6
50.8 (2")	15 - 17	11 - 12
63.5 (2½")		
82.6 (3¼")	33 - 36	25 - 26
101.6 (4")		
127.0 (5")	80 - 85	60 - 64
152.4 (6")		
203.2 (8")	150 - 155	110 - 114
254.0 (10")	200 - 205	148 - 152
304.8 (12")	230 - 235	170 - 175
355.6 (14")	370 - 375	275 - 280

### Manifold Ports

Side lug-mounted cylinders (Style C) can be supplied with the cylinder ports arranged for mounting and sealing to a manifold surface. Manifold ports are available with both single- and double-rodded cylinders. The ports are drilled and counterbored for O-ring seals which are provided. With these specifications, the mounting is designated Style CM. Please consult the factory.

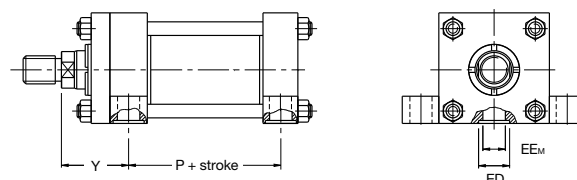

Bore Ø	Rod No.	Y ±0.8	P ±0.8	EE <sub>M</sub>	ED	Parker O-Ring No.
25.4 (1")	1	49.2	54.0	9.5	17.5	2 - 015
38.1 (1½")	1	50.8	54.0	12.7	20.6	2 - 017
50.8 (2")	1	50.8	54.0	12.7	20.6	2 - 017
63.5 (2½")	1	50.8	57.2	12.7	20.6	2 - 017
82.6 (3¼")	1	61.9	66.7	15.9	23.8	2 - 019
101.6 (4")	1	61.9	66.7	15.9	23.8	2 - 019
127.0 (5")	1	61.9	73.0	15.9	23.8	2 - 019
152.4 (6")	1	71.4	79.4	22.2	30.2	2 - 023
203.2 (8")	1	71.4	82.6	22.2	30.2	2 - 023
254.0 (10")	1	79.4	104.8	30.2	38.1	2 - 028
304.8 (12")	1	82.6	117.5	30.2	38.1	2 - 028
355.6 (14")	1	96.8	139.7	39.7	47.6	2 - 131

Dimensions for rod no. 1 only. For alternative rod sizes, please consult the factory.

### Maximum Pressure

The maximum working pressure of 18 bar (250 psi) is based on pure tensile and compressive loadings, without the presence of any bending stresses. Where it is impractical to avoid side loadings, eg: by the use of pivot mountings, please consult the factory giving full details of the application.

In many applications, the pressure developed within a cylinder may be greater than the working pressure, due to pressure intensification across the piston and cushioning, eg: in meter-out circuits. In most cases, this intensification does not affect the cylinder mountings or piston rod threads in the form of increased loading. If the induced pressure with the no. 1 rod exceeds 18 bar (250 psi), please consult the factory.

### inPHorm

For more comprehensive information about pressure limitations for individual cylinders, please refer to the European cylinder inPHorm selection program HY07-1260/Eur.

All dimensions are in millimetres unless otherwise stated.



**Calculation of Cylinder Diameter**

Given that the force and operating pressure of the system are known, and that a piston rod size has been estimated taking account of whether the rod is in tension (pull) or compression (push), then the cylinder bore can be selected.

If the piston rod is in compression, use the 'Push Force' table below, as follows:

1. Identify the operating pressure closest to that required.
2. In the same column, identify the force required to move the load (always rounding up).
3. In the same row, look along to the cylinder bore required.

If the cylinder envelope dimensions are too large for the application, increase the operating pressure, if possible, and repeat the exercise.

If the piston rod is in tension, use the 'Deduction for Pull Force' table. The procedure is the same but, due to the reduced area

caused by the piston rod, the force available on the 'pull' stroke will be smaller. To determine the pull force:

1. Follow the procedure for 'push' applications as described above.
2. Using the 'pull' table, identify the force indicated according to the rod and pressure selected.
3. Deduct this from the original 'push' force. The resultant is the net force available to move the load.

If this force is not large enough, go through the process again but increase the system operating pressure or cylinder diameter if possible. If in doubt, our design engineers will be pleased to assist.

**inPHorm**

For more comprehensive information on the calculation of cylinder bore size required, please refer to the European cylinder inPHorm selection program HY07-1260/Eur.

**Push Force**

Bore Ø	Piston Area		Cylinder Push Force in kN					Cylinder Push Force in Pounds Force					
	mm <sup>2</sup>	sq. in.	2 bar	3.5 bar	5.5 bar	7 bar	18 bar	25 psi	50 psi	65 psi	80 psi	100 psi	250 psi
25.4 (1")	510	0.785	0.1	0.2	0.3	0.4	0.9	20	39	51	65	79	196
38.1 (1½")	1140	1.767	0.2	0.4	0.6	0.8	2.1	44	88	115	142	177	443
50.8 (2")	2020	3.14	0.4	0.7	1.1	1.4	3.6	79	157	204	251	314	785
63.5 (2½")	3170	4.9	0.6	1.1	1.7	2.2	5.7	123	245	319	393	491	1228
82.6 (3¼")	5360	8.3	1.1	1.9	2.9	3.8	9.6	208	415	540	664	830	2075
101.6 (4")	8110	12.5	1.6	2.8	4.5	5.7	14.6	314	628	817	1006	1257	3143
127.0 (5")	12670	20	2.5	4.4	7.0	8.9	22.8	491	982	1277	1571	1964	4910
152.4 (6")	18240	28.3	3.6	6.4	10.0	12.8	32.8	707	1414	1838	2262	2827	7068
203.2 (8")	32430	50.3	6.5	11.4	17.8	22.7	58.4	1257	2513	3268	4022	5027	12568
254.0 (10")	50670	78.5	10.1	17.7	27.9	35.5	91.2	1964	3927	5105	6283	7854	19635
304.8 (12")	72930	113	14.6	25.5	40.1	51.1	131.3	2828	5655	7352	9048	11310	28275
355.6 (14")	99320	154	19.9	34.8	54.6	69.5	178.8	3849	7697	10006	12315	15394	38485

**Deduction for Pull Force**

Piston Rod Ø	Piston Rod Area		Piston Rod Forces in kN					Piston Rod Forces in Pounds Force					
	mm <sup>2</sup>	sq. in.	2 bar	3.5 bar	5.5 bar	7 bar	18 bar	25 psi	50 psi	65 psi	80 psi	100 psi	250 psi
12.7 (½")	130	0.196	0.03	0.05	0.07	0.09	0.2	5	10	13	16	20	49
15.9 (⅝")	200	0.307	0.04	0.07	0.1	0.1	0.4	8	15	20	25	31	77
25.4 (1")	500	0.785	0.1	0.2	0.3	0.4	0.9	20	39	51	65	79	196
34.9 (1⅜")	960	1.49	0.2	0.3	0.5	0.7	1.7	37	75	97	119	149	373
44.5 (1¾")	1560	2.41	0.3	0.5	0.9	1.1	2.8	60	121	157	193	241	603
50.8 (2")	2020	3.14	0.4	0.7	1.1	1.4	3.6	79	157	204	251	314	785
63.5 (2½")	3170	4.9	0.6	1.1	1.7	2.2	5.7	123	245	319	393	491	1228
76.2 (3")	4560	7.0	0.9	1.6	2.5	3.2	8.2	177	354	460	566	707	1767
88.9 (3½")	6210	10	1.2	2.2	3.4	4.3	11.2	241	481	625	770	962	2405
101.6 (4")	8110	12.5	1.6	2.8	4.5	5.7	14.6	314	628	817	1006	1257	3143
127.0 (5")	12670	20	2.5	4.4	7.0	8.9	22.8	491	982	1277	1571	1964	4910
139.7 (5½")	15330	24	3.1	5.4	8.4	10.7	27.6	594	1188	1544	1901	2376	5940

All dimensions are in millimetres unless otherwise stated.



**Piston Rod Size Selection**

The selection of a piston rod for thrust (push) conditions requires the following steps to be carried out:

1. Determine the type of cylinder mounting style and rod end connection to be used. Consult the Stroke Factor table on page 40 and determine which factor corresponds to the application.
2. Using the appropriate stroke factor from page 40, determine the 'basic length' from the equation:  
Basic Length = Net Stroke x Stroke Factor  
(The graph is prepared for standard rod extensions beyond the face of the gland retainers. For rod extensions greater than standard, add the increases to the net stroke to arrive at the 'basic length'.)
3. Calculate the load imposed for the thrust application by multiplying the full bore area of the cylinder by the system pressure, or by referring to the Push and Pull Force charts on page 38.
4. Using the graph below, look along the values of 'basic length' and 'thrust' as found in 2 and 3 above, and note the point of intersection.

The correct piston rod size is read from the diagonally curved line labelled 'Rod Diameter' above the point of intersection.

**Note:** When considering the use of long stroke cylinders, the piston rod should be of sufficient diameter to provide the necessary column strength.

**Stop Tubes**

Stop tubes prevent the cylinder from completing its full stroke, to provide a separation between the piston and the rod bearing at full extension. The required length of stop tube, where necessary, is read from the vertical columns on the right of the

graph by following the horizontal band within which the point of intersection lies. Note that stop tube requirements differ for fixed and pivot mounted cylinders. For cylinders fitted with a stop tube and cushion at the head end, a dual piston arrangement is required – please consult the factory.

If the required length of stop tube is in the region labelled 'consult factory', please submit the following information:

1. Cylinder mounting style.
2. Rod end connection and method of guiding load.
3. Bore required, stroke, length of rod extension (dimension W - dimension V – see pages 20 and 30) if greater than standard.
4. Mounting position of cylinder. (Note if at an angle or vertical, and specify the direction of the piston rod.)
5. Operating pressure of cylinder, if limited to less than the standard pressure for the cylinder selected.

When specifying a cylinder with a stop tube, please insert an S (Special) and the net stroke of the cylinder in the order code and state the length of the stop tube. Note that net stroke is equal to the gross stroke of the cylinder less the length of the stop tube. The gross stroke determines the envelope dimensions of the cylinder. For accurate sizing, please refer to the European cylinder inPHorm selection program HY07-1260/Eur.

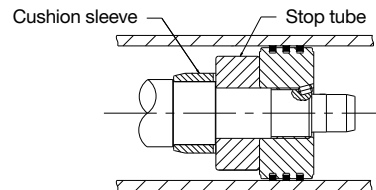

**Piston Rod Selection Chart**

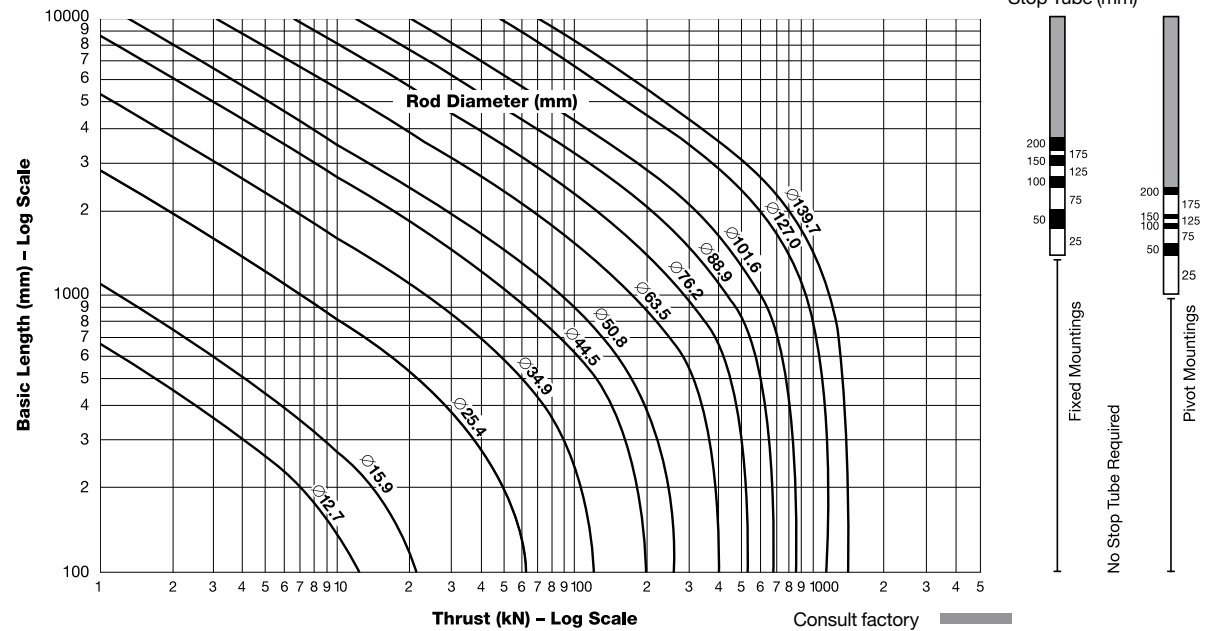

**Stroke Factors**
**Stroke Factors**

The stroke factors which follow are used in the calculation of cylinder 'basic length' – see Piston Rod Size Selection, page 39.

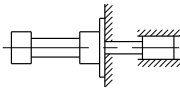
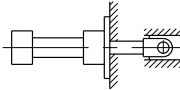
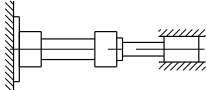
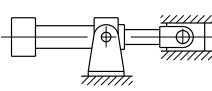
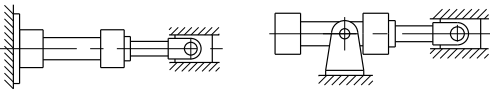
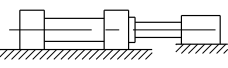
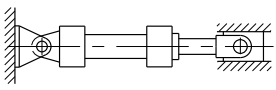
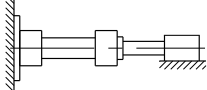
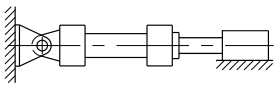
Rod End Connection	Mounting Style	Type of Mounting	Stroke Factor
Fixed and rigidly guided	TB, TD, J, JB, C, F, G		0.5
Pivoted and rigidly guided	TB, TD, J, JB, C, F, G		0.7
Fixed and rigidly guided	TC, H, HB		1.0
Pivoted and rigidly guided	D		1.0
Pivoted and rigidly guided	TC, H, HB, DD		1.5
Supported but not rigidly guided	TB, TD, J, JB, C, F, G		2.0
Pivoted and rigidly guided	BB, DB, BC		2.0
Supported but not rigidly guided	TC, H, HB		4.0
Supported but not rigidly guided	BB, DB, BC		4.0

**Long Stroke Cylinders**

When considering the use of long stroke cylinders, the piston rod should be of sufficient diameter to provide the necessary column strength.

For tensile (pull) loads, rod strength is unaffected by stroke length.

For long stroke cylinders under compressive loads, the use of stop tubes should be considered, to reduce bearing stress.

The Piston Rod Selection Chart on page 39 provides guidance where unusually long strokes are required.

**inPHorm**

For more comprehensive information on the calculation of cylinder bore size required, please refer to the European cylinder inPHorm selection program HY07-1260/Eur.

**An Introduction to Cushioning**

Cushioning is recommended as a means of controlling the deceleration of masses, or for applications where piston speeds are in excess of 0.1m/s and the piston will make a full stroke.

Cushioning extends cylinder life and reduces undesirable noise and pressure peaks.

Deceleration devices or built-in 'cushions' are optional and can be supplied at the head end, cap end, or at both ends of the cylinder without affecting its envelope or mounting dimensions.

**Cushion Length & Piston and Rod Mass**

Where specified, 2A cylinders incorporate the longest cushion sleeve and spear that can be accommodated within the standard envelope without reducing the rod bearing and piston bearing lengths. See table of cushion lengths below. Cushions are adjustable via recessed needle valves.

**inPHorm**

Cushioning requirements can be calculated for individual cylinder/load combinations using the European cylinder inPHorm selection program HY07-1260/Eur.

**Bore Sizes from 25.4mm to 152.4mm (1" to 6")**

Bore Ø	Rod No.	MM Rod Diameter	Cushion Length		Piston & Rod at Zero Stroke kg	Rod Only per 10mm Stroke kg
			Head	Cap		
25,4 (1")	1	12,7 (1/2")	See Note 1		0,18	0,01
	2	15,9 (5/8")			0,23	0,02
38,1 (1 1/2")	1	15,9 (5/8")	22,2	20,6	0,38	0,02
	2	25,4 (1")			0,65	0,04
50,8 (2")	1	15,9 (5/8")	22,2	20,6	0,58	0,02
	2	34,9 (1 3/8")			1,34	0,07
	3	25,4 (1")			0,85	0,04
63,5 (2 1/2")	1	15,9 (5/8")	22,2	20,6	0,91	0,02
	2	44,5 (1 3/4")			2,43	0,12
	3	25,4 (1")			1,18	0,04
82,6 (3 1/4")	1	25,4 (1")	28,6	25,4	1,74	0,04
	2	50,8 (2")			3,71	0,16
	3	34,9 (1 3/8")			2,26	0,07
	4	44,5 (1 3/4")			3,04	0,12
101,6 (4")	1	25,4 (1")	28,6	25,4	2,42	0,04
	2	63,5 (2 1/2")			6,36	0,25
	3	34,9 (1 3/8")			2,93	0,07
	4	44,5 (1 3/4")			3,72	0,12
	5	50,8 (2")			4,39	0,16
127,0 (5")	1	25,4 (1")	28,6	25,4	4,16	0,04
	2	88,9 (3 1/2")			12,91	0,48
	3	34,9 (1 3/8")			4,68	0,07
	4	44,5 (1 3/4")			5,46	0,12
	5	50,8 (2")			6,13	0,16
	6	63,5 (2 1/2")			8,11	0,25
	7	76,2 (3")			10,48	0,35
152,4 (6")	1	34,9 (1 3/8")	34,9	31,8	6,38	0,07
	2	101,6 (4")			18,56	0,63
	3	44,5 (1 3/4")			27,0	0,12
	4	50,8 (2")			27,0	0,16
	5	63,5 (2 1/2")			27,0	0,25
	6	76,2 (3")			27,0	0,35
	7	88,9 (3 1/2")			34,9	0,48

<sup>1</sup> Cushions are not available on 25.4mm (1") bore size.

**Bore sizes from 203.2mm to 355.6mm (8" to 14")**

Bore Ø	Rod No.	MM Rod Diameter	Cushion Length		Piston & Rod at Zero Stroke kg	Rod Only per 10mm Stroke kg		
			Head	Cap				
203,2 (8")	1	34,9 (1 3/8")	27,0	31,8	11,34	0,07		
	2	139,7 (5 1/2")	23,8		39,78	1,19		
	3	44,5 (1 3/4")	27,0		12,15	0,12		
	4	50,8 (2")	27,0		12,85	0,16		
	5	63,5 (2 1/2")	27,0		14,88	0,25		
	6	76,2 (3")	27,0		17,31	0,35		
	7	88,9 (3 1/2")	34,9		19,83	0,48		
	8	101,6 (4")	34,9		23,52	0,63		
	0	127,0 (5")	23,8		33,43	0,98		
	254,0 (10")	1	44,5 (1 3/4")		44,1	44,5	22,97	0,12
3		50,8 (2")	33,3	23,86	0,16			
4		63,5 (2 1/2")	33,3	25,61	0,25			
5		76,2 (3")	33,3	28,13	0,35			
6		88,9 (3 1/2")	33,3	30,95	0,48			
7		101,6 (4")	33,3	34,74	0,63			
9		127,0 (5")	30,1	44,87	0,98			
0		139,7 (5 1/2")	30,1	51,35	1,19			
304,8 (12")		1	50,8 (2")	33,1	44,5		40,36	0,16
		3	63,5 (2 1/2")	33,3			42,11	0,25
	4	76,2 (3")	33,3	44,62		0,35		
	5	88,9 (3 1/2")	33,3	47,44		0,48		
	6	101,6 (4")	33,3	51,23		0,63		
	8	127,0 (5")	30,1	61,36		0,98		
	9	139,7 (5 1/2")	30,1	67,85		1,19		
	355,6 (14")	1	63,5 (2 1/2")	46,0		50,8	65,95	0,25
		3	76,2 (3")	46,0			68,59	0,35
4		88,9 (3 1/2")	46,0	71,05	0,48			
5		101,6 (4")	46,0	75,33	0,63			
7		127,0 (5")	42,9	85,91	0,98			
8		139,7 (5 1/2")	42,9	92,65	1,19			

All dimensions are in millimetres unless otherwise stated.



**Ports**
**Standard Ports**

Series 2A and 2AN cylinders are supplied as standard with R1 size BSPP ports to ISO 228/1, spot faced for sealing washers. Smaller R2 size ports, where demanded by the application, are also available. Parker recommends R1 port sizes for their higher flow rate and piston speed capacity.

Metric threaded ports to DIN 3852 Pt.1, BSPT (taper thread) ports or NPTF ports in sizes as shown for BSPP ports, can be supplied if specified.

Where required, oversize or additional ports can be supplied on the sides of heads and caps that are not occupied by cushion valves. Refer to the tables of port sizes opposite.

**Oversize Ports**

For higher speed applications, oversize ports can be supplied in all bore sizes. Ports one size larger than standard are the maximum that can be accommodated in most heads or caps within the standard envelope dimensions. Certain oversize metric, BSPT or NPTF ports require welded port bosses. The bosses protrude from the side of the cylinder. Port sizes are shown in the tables opposite.

Note that Y and P dimensions may vary slightly to accommodate oversize ports – please contact the factory where these dimensions are critical.

**Manifold Ports**

Manifold ports are available on all mounting styles to special order. Side mounted cylinders (Style C) can be supplied with the cylinder ports arranged for mounting and sealing to a manifold surface – see page 37.

**Ports and Cushion Adjustment Location**

The table below shows standard positions for ports, and cushion adjusting screws where fitted. However, by specifying the position numbers for the desired locations for head and cap ports, many mounting styles can be assembled with ports located at 90° or 180° from standard. In these cases, cushion needle and check valves are also repositioned, where fitted, since their relation with the port position does not change.

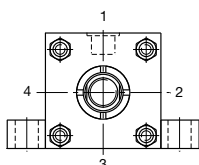

Bore Ø	Standard Port		
	Port Size (BSPP)		Port Size Metric
	R1	R2	
25.4 (1")	G <sup>1</sup> / <sub>4</sub>	G <sup>1</sup> / <sub>4</sub>	M14x1.5
38.1 (1½")	G <sup>3</sup> / <sub>8</sub>	G <sup>1</sup> / <sub>4</sub>	M14x1.5
50.8 (2")	G <sup>3</sup> / <sub>8</sub>	G <sup>1</sup> / <sub>4</sub>	M14x1.5
63.5 (2½")	G <sup>3</sup> / <sub>8</sub>	G <sup>1</sup> / <sub>4</sub>	M14x1.5
82.6 (3¼")	G <sup>1</sup> / <sub>2</sub>	G <sup>1</sup> / <sub>2</sub>	M22x1.5
101.6 (4")	G <sup>1</sup> / <sub>2</sub>	G <sup>1</sup> / <sub>2</sub>	M22x1.5
127.0 (5")	G <sup>1</sup> / <sub>2</sub>	G <sup>1</sup> / <sub>2</sub>	M22x1.5
152.4 (6")	G <sup>3</sup> / <sub>4</sub>	G <sup>3</sup> / <sub>4</sub>	M26x1.5
203.2 (8")	G <sup>3</sup> / <sub>4</sub>	G <sup>3</sup> / <sub>4</sub>	M26x1.5
254.0 (10")	G1	G1	M33x2
304.8 (12")	G1	G1	M33x2
355.6 (14")	G1¼	G1¼	M42x2

Bore Ø	Oversize Port		
	Port Size (BSPP)		Port Size Metric
	R1	R2	
25.4 (1")	G <sup>3</sup> / <sub>8</sub>	G <sup>3</sup> / <sub>8</sub>	M16x1.5
38.1 (1½")	G <sup>1</sup> / <sub>2</sub> <sup>1</sup>	G <sup>3</sup> / <sub>8</sub> <sup>1</sup>	M16x1.5
50.8 (2")	G <sup>1</sup> / <sub>2</sub> <sup>1</sup>	G <sup>3</sup> / <sub>8</sub> <sup>1</sup>	M16x1.5
63.5 (2½")	G <sup>1</sup> / <sub>2</sub> <sup>2</sup>	G <sup>3</sup> / <sub>8</sub> <sup>2</sup>	M16x1.5
82.6 (3¼")	G <sup>3</sup> / <sub>4</sub> <sup>2</sup>	G <sup>3</sup> / <sub>4</sub> <sup>2</sup>	M26x1.5 <sup>2</sup>
101.6 (4")	G <sup>3</sup> / <sub>4</sub> <sup>2</sup>	G <sup>3</sup> / <sub>4</sub> <sup>2</sup>	M26x1.5 <sup>2</sup>
127.0 (5")	G <sup>3</sup> / <sub>4</sub> <sup>2</sup>	G <sup>3</sup> / <sub>4</sub> <sup>2</sup>	M26x1.5 <sup>2</sup>
152.4 (6")	G1 <sup>2</sup>	G1 <sup>2</sup>	M33x2 <sup>2</sup>
203.2 (8")	G1 <sup>2</sup>	G1 <sup>2</sup>	M33x2 <sup>2</sup>
254.0 (10")	G1¼ <sup>2</sup>	G1¼ <sup>2</sup>	M42x2 <sup>2</sup>
304.8 (12")	G1¼ <sup>2</sup>	G1¼ <sup>2</sup>	M42x2 <sup>2</sup>
355.6 (14")	G1½ <sup>2</sup>	G1½ <sup>2</sup>	M48x2 <sup>2</sup>

<sup>1</sup> Requires welded port bosses on both head and cap

<sup>2</sup> Requires welded port bosses on cap only

Position of Ports and Cushion Screws in Head and Cap		Mounting Styles																		
		TB, TC, TD, J, JB, H, HB, BB & BC				C		D		DB		DD				G & F				
Head	Port Cushion	1	2	3	4	1	1	3	1	2	3	4	1	2	3	4	1	2	4	1
		2	3	4	1	2	3	1	3	4	1	2	3	4	1	2	2	4	4	1
Cap	Port Cushion	1	2	3	4	1	1	2	3	4	1	3	1	2	3	4	1	2	4	1
		2	3	4	1	2	3	4	1	2	3	1	3	4	1	2	2	4	4	1

All dimensions are in millimetres unless otherwise stated.



**Removable Trunnions**

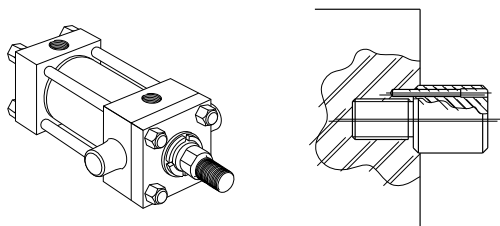

Removable trunnions are available when machine structures or confined space prohibit the use of separate pillow blocks situated close to the cylinder sides. Parker offers a removable trunnion design in 38.1mm to 203.2mm (1½” to 8”) bore sizes. Mounting diameters and lengths are identical to those in mounting style D and DB for any given bore size. These removable trunnions can be provided on the cap end (see ‘Mounting Modifications’ in the order code, page 47) of Series 2A cylinders with any rod diameter. They can also be provided on the head end (see ‘Mounting Modifications’ in the order code, page 47) of cylinders with standard rods (rod no. 1).

Maximum pressure ratings of the removable trunnion mountings are shown in the table below.

Bore Ø	Bar	psi
38.1 to 101.6 (1½” to 4”)	18	250
127.0 (5”)	10	150
152.4 (6”)	13	200
203.2 (8”)	8.5	125

**Single-Acting Cylinders**

Standard 2A series cylinders are of the double-acting type. They are also suitable for use as single-acting cylinders, where the load or other external force is used to return the piston after the pressure stroke.

**Spring-Returned, Single-Acting Cylinders**

Series 2A single-acting cylinders can also be supplied with an internal spring to return the piston after the pressure stroke. Please supply details of load conditions and friction factors, and advise whether the spring is required to advance or return the piston rod.

On spring-returned cylinders, it is recommended that tie rod extensions be specified on the cylinder end in which the spring is located to allow the spring to be ‘backed off’ until compression is relieved. Tie rod nuts should be welded to the tie rods at the opposite end of the cylinder, to further assure safe disassembly. Please consult the factory when ordering spring-returned cylinders.

**Stroke Limiter**

Where absolute precision in stroke length is required, a screwed adjustable stop can be supplied. Several types are available – the illustration shows a design suitable for infrequent adjustment at the uncushioned cap end of a cylinder. Please contact the factory, specifying details of the application and the adjustment required.

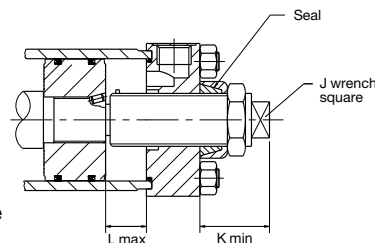

Bore Ø	J	K min	L max
38.1 (1½”)	11	85	127.0
50.8 (2”)	17	85	127.0
63.5 (2½”)	17	85	203.2
82.6 (3¼”)	17	85	203.2
101.6 (4”)	17	85	203.2
127.0 (5”)	17	85	228.6
152.4 (6”)	22	85	228.6
203.2 (8”)	22	85	457.2

**Multiple Stroke Positioning**

To obtain linear force in one plane with controlled stopping at intermediate points, several designs are available. For three stopped positions, it is common practice to mount two standard single rod Style H cylinders back-to-back, or to use through-tie rods. By extending or retracting the stroke of each cylinder independently, it is possible to achieve three positions at the piston ends. An alternative technique is to use a tandem cylinder with an independent piston rod in the cap section. Please consult the factory for further details.

**Rod End Bellows**

Unprotected piston rod surfaces which are exposed to contaminants with air hardening properties should be protected by rod end bellows. Longer rod extensions are required to accommodate the collapsed length of the bellows. Please consult the factory for further information.

**Metallic Rod Wipers**

Metallic rod wipers replace the standard wiper seal, and are recommended where dust, ice or splashing might damage the wiper seal material. Metallic rod wipers do not affect cylinder dimensions.

**DC Proximity Sensors**

These can be fitted to give reliable end of stroke signals. Please consult the factory for further information.

All dimensions are in millimetres unless otherwise stated.



**Service Assemblies and Seal Kits**

Service Assembly Kits and Seal Kits for 2A cylinders simplify the ordering and maintenance processes. They contain sub-assemblies which are ready for installation, and are supplied with full instructions. When ordering Service Assemblies and Seal Kits, please refer to the identification plate on the cylinder body, and supply the following information:

**Serial Number - Bore - Stroke - Model Number - Fluid Type**

**Key to Part Numbers**

- 1 Head
- 7 Cap
- 14 Gland/bearing cartridge
- 15 Cylinder body
- 17 Piston (Lipseal)
- 18 Cushion sleeve
- 19 Tie rod
- 23 Tie rod nut
- 27 Retainer
- 34 Piston rod – single rod, no cushion
- 35 Piston rod – single rod, cushion at head end
- 36 Piston rod – single rod, cushion at cap end
- 37 Piston rod – single rod, cushion at both ends
- 40 Wiperseal – for gland
- 41 Lipseal – for gland
- 42 Lipseal – for piston

- 70 Needle valve, cushion adjustment (bore sizes above 63.5mm)
- 70a Needle valve assembly, cartridge type (bore sizes up to 63.5mm)
- 71 Ball – cushion check valve
- 72 Cushion check valve screw
- 73 Floating cushion bush
- 74 Retaining ring for cushion bush

<sup>1</sup> Not illustrated

<sup>2</sup> See page 21 – double rod cylinders

Piston Rod Ø	Gland Cartridge Wrench	Spanner Wrench
12.7 (1/2")	69590	11676
15.9 (5/8")	69590	11676
25.4 (1")	69591	11676
34.9 (1 3/8")	69592	11703
44.5 (1 3/4")	69593	11677
50.8 (2")	69594	11677
63.5 (2 1/2")	69595	11677
76.2 (3")	69596	11677
88.9 (3 1/2")	69597	11677
101.6 (4")	69598	11677
127.0 (5")	69599	11678
139.7 (5 1/2")	69600	11678

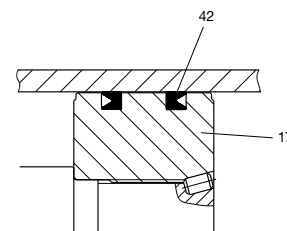
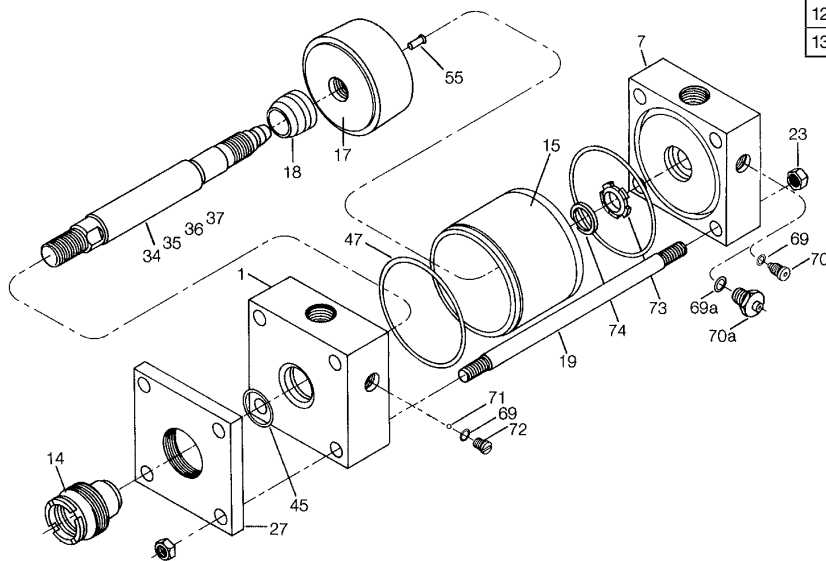

**Lipseal Piston**

- 43 Back-up washer for gland lipseal 41
- 45 O-ring – gland/head
- 47 O-ring – cylinder body
- 55 Locking pin – piston/rod
- 57 <sup>1</sup> Piston rod – double (stronger <sup>2</sup>) rod, no cushion
- 58 <sup>1</sup> Piston rod – double (stronger <sup>2</sup>) rod, cushion one end
- 60 <sup>1</sup> Piston rod – double (weaker <sup>2</sup>) rod, no cushion
- 61 <sup>1</sup> Piston rod – double (weaker <sup>2</sup>) rod, cushion one end
- 69 O-ring – needle valve and check valve screws
- 69a O-ring – cartridge-type needle valve

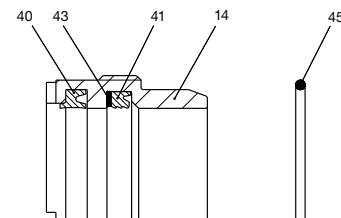

**Gland Cartridge and Seals**



**Contents and Part Numbers of Seal Kits for Pistons and Glands**

(see key to part numbers opposite)

**Gland Cartridge Service Kit**

Contains items 14, 40, 41, 43, 45.

**Gland Service Kit**

Contains items 40, 41, 43, 45.

Piston Rod Ø	Gland Cartridge Service Kit, Standard Seals *	Gland Service Kit, Standard Seals *
12.7 (1/2")	RG2AHL051	RK2AHL051
15.9 (5/8")	RG2AHL061	RK2AHL061
25.4 (1")	RG2AHL101	RK2AHL101
34.9 (1 3/8")	RG2AHL131	RK2AHL131
44.5 (1 3/4")	RG2AHL171	RK2AHL171
50.8 (2")	RG2AHL201	RK2AHL201
63.5 (2 1/2")	RG2AHL251	RK2AHL251
76.2 (3")	RG2AHL301	RK2AHL301
88.9 (3 1/2")	RG2AHL351	RK2AHL351
101.6 (4")	RG2AHL401	RK2AHL401
127.0 (5")	RG2AHL501	RK2AHL501
139.7 (5 1/2")	RG2AHL551	RK2AHL551

**Piston Service Kit, Lipseal Piston**

Contains two each of items 42 and 47.

Bore Ø	Piston Service Kit, Lipseal Piston *
25.4 (1")	PK1002A001
38.1 (1 1/2")	PK1502A001
50.8 (2")	PK2002A001
63.5 (2 1/2")	PK2502A001
82.6 (3 1/4")	PK3202A001
101.6 (4")	PK4002A001
127.0 (5")	PK5002A001
152.4 (6")	PK6002A001
203.2 (8")	PK8002A001
254.0 (10")	PK9002A001
304.8 (12")	PK9202A001
355.6 (14")	PK9402A001

**\* Seal Groups – Ordering**

The part numbers shown in the tables above are for Group 1 seals. For Group 5 seals, substitute a '5' for the '1' at the end of the number sequence. For example, a Group 5 RG gland cartridge kit for a 50.8mm bore cylinder will be RG2AHL205.

**Service Kits**
**Group 1 Service Kits** contain seals of Nitrile (Buna-N) elastomers.

**Group 5 Service Kits** contain seals of fluorocarbon elastomers.

For further information on seals please refer to page 5.

**Tie Rod Torques**

Please refer to the table on page 37.

**Contents and Part Numbers of Service Assembly Kits**

(see key to part numbers opposite)

**Head Assembly**

Non-cushioned: 1, 47

Cushioned: 1, 47, 69, (69a), 70, (70a), 71, 72

**Cap Assembly**

Non-cushioned: 7, 47

Cushioned: 7, 47, 69, (69a), 70, (70a), 73, 74

**Cylinder Body**

All types: 15

**Cushion Screw/Cartridge Assembly**

Screw type: 69, 70

Cartridge type: 69a, 70a

**Check Valve Screw Assembly**

Screw type: 69, 71, 72

**Piston Rod Assemblies**

These kits contain a fully assembled piston and rod assembly which is ready to install. They comprise a piston assembly, plus a rod assembly from the types listed below.

**Piston Assemblies**

Lipseal: 17, 42, 44

**Rod Assemblies**

Single rod, non-cushioned: 34

Single rod, cushioned head: 35, 18

Single rod, cushioned cap: 36

Single rod, cushioned both ends: 37, 18

Double rod, non-cushioned: 57, 60,

Double rod, cushioned stronger end: 58, 60, 18

Double rod, cushioned weaker end: 58, 61, 18

Double rod, cushioned both ends: 58, 61, 18 x 2

**Repairs**

Although 2A cylinders are designed to make on-site maintenance or repairs as easy as possible, some operations can only be carried out in our factory. It is standard policy to fit a cylinder returned to the factory for repair with those replacement parts which are necessary to return it to 'as good as new' condition. Should the condition of the returned cylinder be such that repair would be uneconomical, you will be notified.

**Non-Lubricated Service Kits**

Service kits for 2AN Series non-lubricated air cylinders are shown on page 35.

**Parker "Lube-A-Cyl" Air Cylinder Lubricant**

"Lube-A-Cyl" is intended as a supplement to normal lubrication methods, and is recommended for use during reassembly of air cylinders after servicing. It also helps to prevent damage to static and dynamic seals. This multi-purpose lubricant is available in 110g (4 oz) tubes, part no. 76163.



**Storage Information and Masses**

**Storage**

When cylinders must be stored for a period of time, the following procedures are recommended:

1. Store the cylinders in an indoor area which has a dry, clean and non-corrosive atmosphere. Take care to protect the cylinder from both internal corrosion and external damage.
2. Whenever possible, cylinders should be stored in a vertical position (piston rod up). This will minimize corrosion due to possible condensation which could occur inside the cylinder, and seal set due to the weight of the piston and rod assembly.
3. Port protector plugs should be left in the cylinder until the time of installation.
4. For long duration storage add a vapour phase inhibitor to both sides of the piston to prevent internal corrosion.

**Installation**

1. Cleanliness is an important consideration, and Parker cylinders are shipped with the ports plugged to protect them from contaminants entering the ports. These plugs should not be removed until the piping is to be installed. Before making the connection to the cylinder ports, piping should be thoroughly cleaned to remove all chips or burrs which might have resulted from threading or flaring operations.
2. Cylinders operating in an environment where air drying materials are present such as fast-drying chemicals, paint, or weld splatter, or other hazardous conditions such as excessive heat, should have shields installed to prevent damage to the piston rod and piston rod seals.
3. Correct alignment of the cylinder piston rod and its mating component on the machine should be checked in both the extended and retracted positions. Incorrect alignment will result in excessive rod gland and/or cylinder bore wear, shortening the life of the cylinder.

**Warranty**

**Defective Work or Material** Every effort is made to ensure sound material and good workmanship, but the Seller gives no warranty, expressed or implied, of material, workmanship, or fitness of goods for any particular purpose, whether such purpose be known to the Seller or not. In the event of any material or workmanship proving defective the Seller is prepared to rectify or replace such material at the place of delivery and in the condition originally specified, or if rectification or replacement is not practicable, will credit the value of the goods at the invoice price, if required in writing to do so, provided always that the claim is made and admitted and the material is returned within six months from date of invoice. The Seller's liability in respect of or consequent upon any such defect whether in original or replaced material or workmanship, is limited as aforesaid and does not extend in any circumstances to cover any other expenditure incurred nor any consequential damages or loss of profit.

**Masses – Series 2A Cylinders**

To determine the mass of the cylinder, first select the basic mass for zero stroke from the table, then calculate the mass for the cylinder stroke and add the result to the basic mass. Masses for accessories are shown on pages 31 to 33.

All dimensions are in millimetres unless otherwise stated.

Bore Ø	Rod No.	Single Rod Cylinders			Double Rod Cylinders		
		Mass at Zero Stroke		Mass per 10mm Stroke (kg)	Mass at Zero Stroke		Mass per 10mm Stroke (kg)
		Mounting Styles			Mounting Styles		
TB, TC, TD, J, JB, H, HB, F (kg)	C, G, BB, BC, D, DB, DD (kg)		TB, TD, J, JB, F (kg)	C, G, D, DD (kg)			
25.4 (1")	1	1.2	1.3	0.04	1.5	1.7	0.05
	2	1.2	1.4	0.04	1.6	1.9	0.06
38.1 (1½")	1	1.9	2.2	0.05	2.4	2.9	0.07
	2	2.2	2.6	0.08	2.9	3.7	0.12
50.8 (2")	1	3.0	3.4	0.07	3.7	4.4	0.08
	2	3.6	4.3	0.13	4.8	6.2	0.20
	3	3.2	3.5	0.09	4.0	4.8	0.13
63.5 (2½")	1	4.4	4.6	0.08	5.4	5.9	0.09
	2	5.5	6.7	0.18	7.6	10.1	0.30
	3	4.5	4.9	0.10	5.7	6.5	0.14
	4	4.9	5.6	0.14	6.4	7.8	0.21
82.6 (3¼")	1	8.3	9.0	0.12	10.5	11.8	0.16
	2	9.6	11.5	0.24	13.0	16.8	0.40
	3	8.6	9.6	0.16	11.0	12.9	0.23
	4	9.1	10.6	0.20	12.1	15.0	0.32
101.6 (4")	1	11.9	12.5	0.14	15.0	16.3	0.18
	2	14.6	17.9	0.34	21.0	28.0	0.59
	3	12.2	13.2	0.17	15.6	17.5	0.25
	4	12.7	14.2	0.22	16.6	19.5	0.34
	5	13.2	15.0	0.26	17.5	21.3	0.41
127.0 (5")	1	18.5	19.5	0.17	23	25	0.21
	2	24.6	32.0	0.61	36	50	1.10
	3	18.8	20.0	0.21	24	27	0.28
	4	19.3	21.1	0.25	25	29	0.37
	5	19.7	22.0	0.29	26	31	0.45
	6	21.2	24.9	0.38	29	36	0.62
	7	22.9	28.3	0.49	32	43	0.84
152.4 (6")	1	30.0	33	0.23	37	44	0.31
	2	38.0	48	0.79	54	73	1.50
	3	29.9	32	0.28	38	42	0.40
	4	31.0	35	0.32	39	48	0.47
	5	32.0	38	0.40	42	54	0.65
	6	34.0	41	0.51	45	60	0.87
	7	35.0	44	0.64	48	66	1.20
203.2 (8")	1	52	57	0.43	64	74	0.50
	2	72	98	1.60	105	156	2.80
	3	52	58	0.47	65	76	0.60
	4	53	59	0.51	66	78	0.67
	5	54	61	0.60	68	83	0.85
	6	56	65	0.71	72	90	1.10
	7	57	68	0.84	75	96	1.40
	8	60	73	1.00	80	107	1.60
0	67	88	1.40	95	137	2.40	
254.0 (10")	1	96	108	0.57	112	124	0.70
	3	97	109	0.61	113	125	0.76
	4	98	111	0.69	115	128	0.94
	5	100	114	0.80	119	133	1.20
	6	102	118	0.93	122	138	1.40
	7	104	123	1.10	128	147	1.70
	9	112	138	1.50	142	168	2.40
	0	117	148	1.70	152	183	2.80
304.8 (12")	1	146	161	0.68	168	183	0.83
	3	147	163	0.76	171	187	1.00
	4	149	166	0.87	174	191	1.30
	5	151	170	1.00	178	197	1.50
	6	154	176	1.20	183	205	1.80
	8	161	191	1.50	198	228	2.50
9	166	200	1.70	208	242	2.90	
355.6 (14")	1	228	250	0.87	266	288	1.20
	3	230	253	0.98	269	292	1.40
	4	231	256	1.10	272	297	1.60
	5	234	262	1.30	278	306	1.90
	7	242	277	1.60	292	327	2.60
	8	246	286	1.80	302	342	3.00



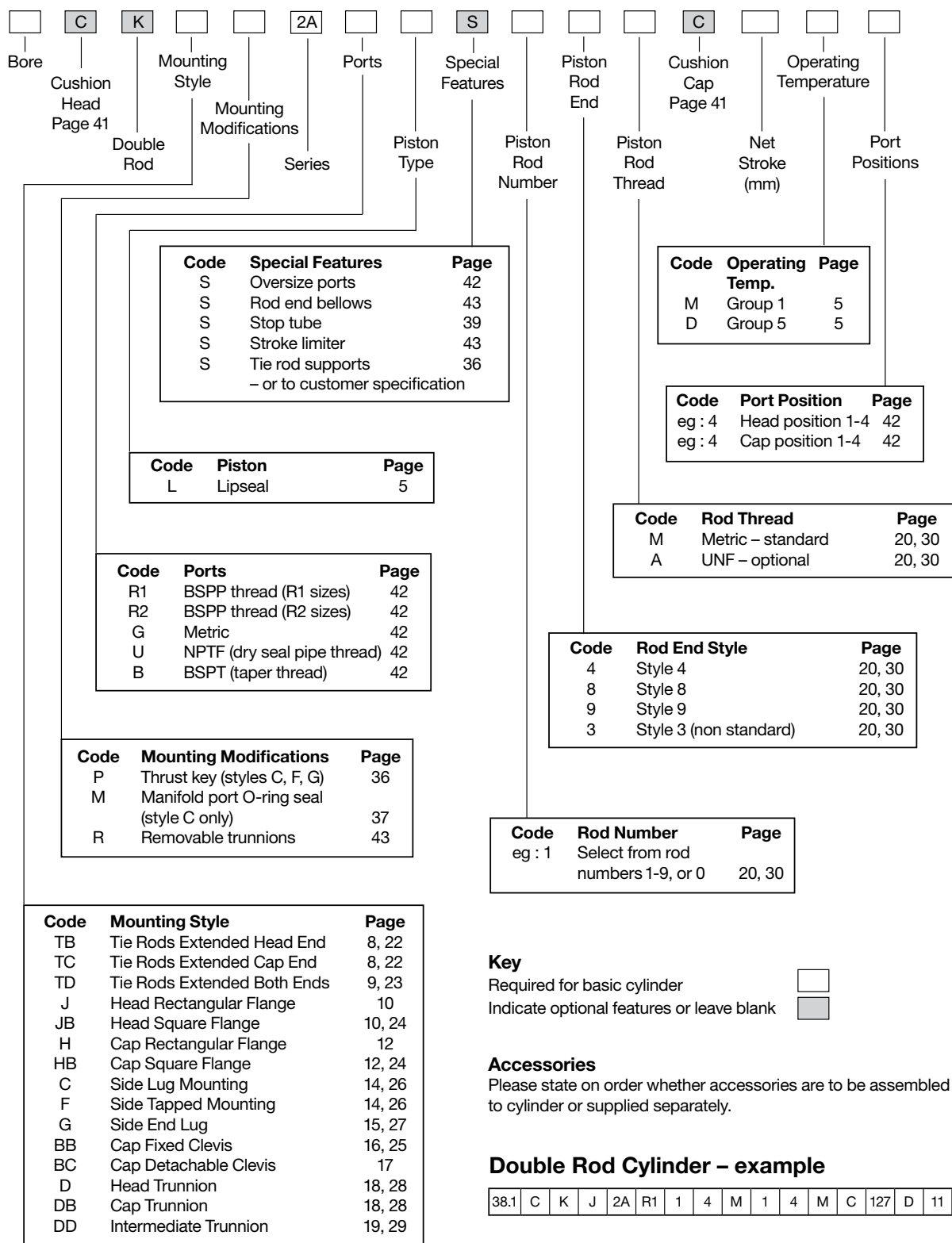

## Parker Worldwide

**AE – UAE, Dubai**

Tel: +971 4 8127100  
parker.me@parker.com

**AR – Argentina, Buenos Aires**

Tel: +54 3327 44 4129

**AT – Austria, Wiener Neustadt**

Tel: +43 (0)2622 23501-0  
parker.austria@parker.com

**AT – Eastern Europe,**

Wiener Neustadt  
Tel: +43 (0)2622 23501 900  
parker.easteurope@parker.com

**AU – Australia, Castle Hill**

Tel: +61 (0)2-9634 7777

**AZ – Azerbaijan, Baku**

Tel: +994 50 2233 458  
parker.azerbaijan@parker.com

**BE/LU – Belgium, Nivelles**

Tel: +32 (0)67 280 900  
parker.belgium@parker.com

**BR – Brazil, Cachoeirinha RS**

Tel: +55 51 3470 9144

**BY – Belarus, Minsk**

Tel: +375 17 209 9399  
parker.belarus@parker.com

**CA – Canada, Milton, Ontario**

Tel: +1 905 693 3000

**CH – Switzerland, Etoy**

Tel: +41 (0) 21 821 02 30  
parker.switzerland@parker.com

**CL – Chile, Santiago**

Tel: +56 2 623 1216

**CN – China, Shanghai**

Tel: +86 21 5031 2525

**CZ – Czech Republic, Klecany**

Tel: +420 284 083 111  
parker.czechrepublic@parker.com

**DE – Germany, Kaarst**

Tel: +49 (0)2131 4016 0  
parker.germany@parker.com

**DK – Denmark, Ballerup**

Tel: +45 43 56 04 00  
parker.denmark@parker.com

**ES – Spain, Madrid**

Tel: +34 902 33 00 01  
parker.spain@parker.com

**FI – Finland, Vantaa**

Tel: +358 (0)20 753 2500  
parker.finland@parker.com

**FR – France, Contamine s/Arve**

Tel: +33 (0)4 50 25 80 25  
parker.france@parker.com

**GR – Greece, Athens**

Tel: +30 210 933 6450  
parker.greece@parker.com

**HK – Hong Kong**

Tel: +852 2428 8008

**HU – Hungary, Budapest**

Tel: +36 1 220 4155  
parker.hungary@parker.com

**IE – Ireland, Dublin**

Tel: +353 (0)1 466 6370  
parker.ireland@parker.com

**IN – India, Mumbai**

Tel: +91 22 6513 7081-85

**IT – Italy, Corsico (MI)**

Tel: +39 02 45 19 21  
parker.italy@parker.com

**JP – Japan, Fujisawa**

Tel: +(81) 4 6635 3050

**KR – South Korea, Seoul**

Tel: +82 2 559 0400

**KZ – Kazakhstan, Almaty**

Tel: +7 7272 505 800  
parker.easteurope@parker.com

**LV – Latvia, Riga**

Tel: +371 6 745 2601  
parker.latvia@parker.com

**MX – Mexico, Apodaca**

Tel: +52 81 8156 6000

**MY – Malaysia, Shah Alam**

Tel: +60 3 7849 0800

**NL – The Netherlands,**

Oldenzaal  
Tel: +31 (0)541 585 000  
parker.nl@parker.com

**NO – Norway, Ski**

Tel: +47 64 91 10 00  
parker.norway@parker.com

**NZ – New Zealand, Mt Wellington**

Tel: +64 9 574 1744

**PL – Poland, Warsaw**

Tel: +48 (0)22 573 24 00  
parker.poland@parker.com

**PT – Portugal, Leca da Palmeira**

Tel: +351 22 999 7360  
parker.portugal@parker.com

**RO – Romania, Bucharest**

Tel: +40 21 252 1382  
parker.romania@parker.com

**RU – Russia, Moscow**

Tel: +7 495 645-2156  
parker.russia@parker.com

**SE – Sweden, Spånga**

Tel: +46 (0)8 59 79 50 00  
parker.sweden@parker.com

**SG – Singapore**

Tel: +65 6887 6300

**SK – Slovakia, Banská Bystrica**

Tel: +421 484 162 252  
parker.slovakia@parker.com

**SL – Slovenia, Novo Mesto**

Tel: +386 7 337 6650  
parker.slovenia@parker.com

**TH – Thailand, Bangkok**

Tel: +662 717 8140

**TR – Turkey, Istanbul**

Tel: +90 216 4997081  
parker.turkey@parker.com

**TW – Taiwan, Taipei**

Tel: +886 2 2298 8987

**UA – Ukraine, Kiev**

Tel +380 44 494 2731  
parker.ukraine@parker.com

**UK – United Kingdom,**

Warwick  
Tel: +44 (0)1926 317 878  
parker.uk@parker.com

**US – USA, Cleveland**

(industrial)  
Tel: +1 216 896 3000

**US – USA, Lincolnshire**

(mobile)  
Tel: +1 847 821 1500

**VE – Venezuela, Caracas**

Tel: +58 212 238 5422

**ZA – South Africa,**

Kempton Park  
Tel: +27 (0)11 961 0700  
parker.southafrica@parker.com

**European Product Information Centre**

Free phone: 00 800 27 27 5374  
(from AT, BE, CH, CZ, DE, DK, ES, FI, FR,  
IE, IT, NL, NO, PL, PT, RU, SE, UK, ZA)  
Fax: +44 1442 458112

US Product Information Centre  
Free phone: 1-800-27 27 537

[www.parker.com](http://www.parker.com)

Your local authorized Parker distributor