



Hydraulic Hoses, Fittings and Equipment

Catalogue



ENGINEERING YOUR SUCCESS.

Contents

| | | |
|----------------------------------------------------|-----|---------|
| Introduction | | 2 – 33 |
| Technical handbook | | |
| Crimp systems you can trust | A | 2 – 5 |
| Hoses and fittings terminology – the basics | Aa | 2 – 8 |
| Safe hose assemblies – working steps | Aa | 9 – 19 |
| How to order (Part Number description) | Aa | 20 – 21 |
| Identifying fitting types | Aa | 22 – 29 |
| Storage – Hoses and hose fittings | Aa | 30 – 31 |
| Safety first! – Parker safety guide | Aa | 32 – 38 |
| Technical data | Ab | 2 – 34 |
| Low Pressure Push-Lok | | |
| Push-Lok Hoses | B1a | 1 – 10 |
| Fittings 82 series | B1b | 1 – 18 |
| Assembly Instructions | B1b | 19 |
| Low Pressure Transportation and Hydraulic | | |
| Low Pressure Hoses | B2a | 1 – 10 |
| Fittings 26 series | B2b | 1 – 7 |
| Medium Pressure | | |
| GlobalCore Parkrimp No-Skive Hoses | Caa | 1 – 9 |
| Parkrimp No-Skive Hoses | Cab | 1 – 39 |
| Fittings 43 series | Cb | 1 – 15 |
| Fittings 46 and 48 series | Cc | 1 – 42 |
| Fittings 2piece 48 series | Cd | 1 – 2 |
| Fittings 2piece IF series | Ce | 1 – 3 |
| High Pressure | | |
| GlobalCore Parkrimp No-Skive Hoses | Daa | 1 – 9 |
| Parkrimp No-Skive and ParLock Skive Hoses | Dab | 1 – 33 |
| Fittings 70 series | Db | 1 – 18 |
| Fittings 73 series | Dc | 1 – 20 |
| Fittings 77 series | Dd | 1 – 25 |
| Fittings VS series | De | 1 – 15 |
| Fittings V4/V6 series | Df | 1 – 25 |
| Fittings V5 series | Dg | 1 – 3 |
| Fittings WB series | Dh | 1 – 4 |
| Machines, Tooling, Accessories | | |
| Machines | Ea | 1 – 33 |
| Accessories | Eb | 1 – 24 |
| Assembly Instructions | Ec | 1 – 2 |
| Your Crimp Source online | Ed | 1 |

Technical handbook

Low Pressure Push-Lok

The intelligent Push-Lok System covering different types of rubber, thermoplastic as well as a hybrid hose version and a wide selection of reusable fittings made of steel, brass and stainless steel.

Pressure range
up to 2.8 MPa

Low Pressure Transportation and Hydraulics

This low pressure range follows the No-Skive concept and the majority can be assembled on Parkrimp machines.

Pressure range
up to 20.7 MPa

Medium Pressure

Hose and fitting product range for applications in mobile and industrial hydraulics.

The perfect range for the more demanding market requirements with a broad selection of Parkrimp No-Skive fittings, with over sixty end configurations, combined with Parker hoses and crimpers allows simple and safe assembly – whenever and wherever needed.

Pressure range
up to 45.0 MPa

High Pressure

Heavy-duty products for heavy-duty applications with a full range of Parkrimp No-Skive multispiral hoses and fittings and ParLock skive type hoses and fittings.

Pressure range
up to 69.0 MPa

Machines, Tooling, Accessories

The perfect complement to the largest range of hoses and fittings in the market. Parker crimping technology is recognised throughout the industry as the easiest and most accurate crimping system available.

SOLVING THE WORLD'S GREATEST ENGINEERING CHALLENGES.

Our focus on solving some of the world's greatest engineering challenges sparks our passion for innovation and secures our future growth.



The development of more efficient energy sources; the desire to produce and distribute clean water; new drug discovery and medical advances; the building of infrastructure and transportation to support a growing population; the safe cultivation, transportation and preservation of food sources; emerging developments in defense; and the protection of our environment – all of these challenges drive Parker people forward, seeking new ways to innovate, combine technologies, collaborate, develop systems and partner with our customers to solve problems.

ENGINEERING YOUR SUCCESS.

It's more than a tagline – it's an anchor that ensures our progress is grounded in the principles that have made our company a success. The Parker brand represents a promise backed by 57,000 team members to improve our customers' productivity and profitability.

Our success is achieved in partnership with our customers and distributors in 50 countries who extend our reach with the same goals to innovate, improve efficiencies and create intelligent solutions.

PARKER HANNIFIN – THE GLOBAL LEADER AND YOUR PARTNER

Parker provides an unparalleled range of products and solutions in an array of diversified industrial and aerospace markets.

We are always exploring new ways to enhance our manufacturing processes and tools, testing capabilities and research and development.

The Parker Technology Center advances enterprise-wide priorities while our operating group centers focus on specific technologies. This strategy offers the best of both worlds: traditional product and application engineering supplemented with advanced design and manufacturing processes.

Our technical fellows and subject matter experts are supported by a large number of engineers and specialists with advanced degrees and training.

Regular and consistent training and problem solving techniques enable high performance teams to make a significant impact across the business.



PARKER CORE TECHNOLOGIES





Polymer Hose Division Europe

The market leader and your supplier of choice.



Put a bite on the braid.

Parker's world-recognized tiger mascot has represented the Parkrimp No-Skive hose assembly program since its introduction in 1980. In a contest originally held by our marketing department, the tiger was the winning suggestion over three others: a turtle (deemed "too slow"), an alligator ("not very good looking") and a shark ("too intimidating" particularly at the time of the release of the movie Jaws).

More than three decades later, the tiger graphic still supports the Parkrimp message everywhere, clearly symbolizing our unique, patented Parkrimp fittings with tapered steel teeth and our Parkrimp crimping machines. Their ability to eliminate hose cover skiving and achieve the metal-to-metal grip of factory assemblies revolutionized the process for markets worldwide. And today, it's the industry standard.

Pride in our products: At Parker, we believe the best fluid connector products for your operation are the ones that get the job done right. We offer the most comprehensive line of hoses, fittings, equipment and accessories you'll need. And if there's something you need that's not a standard product, we're able to design and manufacture it for you with ease.

You'll also benefit from our ultimate competitive advantage – our network of distribution outlets that can provide our products nearly anytime and anywhere. We strive to provide customers with local engineering, local products and local service.

Parker offers the largest selection of hoses plus more fitting sizes than any other manufacturer. You'll find a wide variety of hoses including braided, spiral and multi-purpose, and more than 4,500 Parkrimp fittings. Parker products have been designed, tested and approved to meet and exceed global standards.



The right product is available for your application, including hose that features a variety of abrasion resistant cover choices, flexibility, a wide range of media compatibility and more – characteristics that make Parker the hose supplier of choice for customers that demand the most from their equipment.



A long history of providing premier customer service.

Our plant in Veniano, Italy is our precision-engineered-solution center for products, materials and processes, and is equipped with state-of-the-art development, testing and perfor-

mance technology. All manufacturing locations our Polymer Hose Division provide a quality product on time. Knowing that uptime and productivity are major drivers in your business

success, we proudly present this catalog outlining Parker's best-in-class hose products and services.



Low, Medium, High and Ultra Pressure Hose



Parkrimp® Hose Fittings

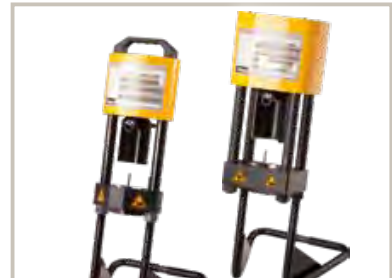

Parkrimp® Assembly Equipment

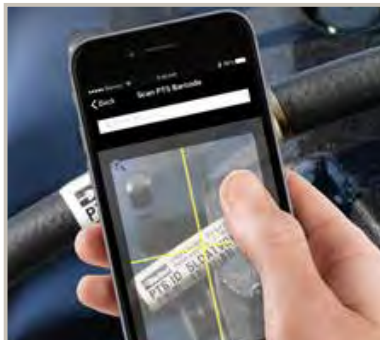

Mobile Phone Applications



Parker Tracking System

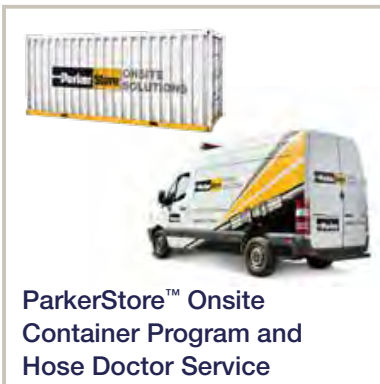

ParkerStore™ Onsite Container Program and Hose Doctor Service



Custom Hose Assemblies and Hose Fittings



Accessories

Good – Better – Best – engineered for your success.

The classification for easier hose and fitting selection



Parker Polymer Hose Division Europe supplies premier service by focussing on customer needs. To engineer customer's success by offering diversified products, we introduce a "Good, Better, Best" classification according to the quality standards and in line with the requirements of the individual applications.

Customer's choice is the key.

Good

BCH medium and **SX** high pressure hoses – meeting international technical standards – developed for demanding small and medium OEMs and general distribution.

Medium Pressure

BCH1
BCH2

Fitting Series



High Pressure

SX35
SX42

Fitting Series



* MP (Multipack) only

Better

Well known *Elite No-Slave* medium and **Parkrimp® No-Slave** high pressure hoses – exceeding the standards – highly appreciated in the very demanding MRO and OEM markets.

Medium Pressure

Elite
462, 492

Fitting Series



High Pressure

Parkrimp
701, 731

Fitting Series



Best

State-of-the-art **GLOBALCORE™** hose product range – exceeding the newest ISO 18752 – providing technical and economical excellence to the most demanding customers.

Medium Pressure

GLOBALCORE™
387, 487

Fitting Series



High Pressure

GLOBALCORE™
787, 797

Fitting Series



Customers choice is the key

Good, Better, Best classification for easier hose and fitting selection

- Different levels for different markets and applications
- Help customers to make better buying decision
- Defined hose and fitting combination on hose layline
- Clear visibility of correct fitting
- Easy to understand
- Ensures quality of hose and fitting combination

Superior performance of Best hoses versus Better and Good hoses

- Bend radius up to 50% smaller
- Flexibility (bending force) up to 30% higher
- Weight up to 20% lower
- Dimensions up to 25% smaller area
- Impulse resistance and service life up to four times higher
- Working temperature up to 25% higher

Especially developed Good hoses

- Medium pressure **Good** hose types BCH1, BCH2 with the fitting series 46 and 48
- High pressure **Good** hose types SX 35 and SX 42 with fitting series 73 and 77



GlobalCore™

The world's first high-performance, cohesive hose and fitting system.

Providing a simple solution of robust hydraulic hoses designed to endure the tough conditions where work gets done, GlobalCore is the future that OEMs and end users around the world have been asking for.

You know Parker as the global leader in providing unprecedented performance and value for hydraulic systems with high-pressure applications. With our GlobalCore solution, you can significantly reduce your inventory and part number complexity by using just five hoses and two fittings.

Designed to meet the most common working pressures in industry, GlobalCore stands above the competition and serves customers around the world with a simple family of constant working pressure hoses.

Designed, built and tested to the ISO 18752 specification, GlobalCore reduces engineering and service complexity by providing the first comprehensive product family across the most commonly used constant working pressure classes.

| Hoses | -4 | -6 | -8 | -10 | -12 | -16 | -20 | -24 | -32 | -40 | -48 |
|--------------------|-----|---------|---------|---------|---------|---------|-----|-----|-----|-----|-----|
| 7 MPa / 1,000 psi | | | 187 | 187 | 187 | 187 | 187 | 187 | 187 | 187 | 187 |
| 21 MPa / 3,000 psi | 387 | 387 | 387 | 387 | 387 | 387 | 387 | 387 | 387 | | |
| 28 MPa / 4,000 psi | 487 | 487/722 | 487/722 | 487/722 | 487/722 | 487/722 | 487 | 487 | 487 | | |
| 35 MPa / 5,000 psi | 787 | 787 | 787 | 787 | 787 | 787 | 787 | 787 | 787 | | |
| 42 MPa / 6,000 psi | 797 | 797 | 797 | 797 | 797 | 797 | 797 | 797 | 797 | | |

| Fittings | -4 | -6 | -8 | -10 | -12 | -16 | -20 | -24 | -32 | -40 | -48 |
|--------------------|-------|-------|-------|-------|-------|-------|-------|-------|-------|-----------|-----------|
| 7 MPa / 1,000 psi | | | 43/48 | 43/48 | 43/48 | 43/48 | 43/48 | 43/48 | 43/48 | 2piece 48 | 2piece 48 |
| 21 MPa / 3,000 psi | 43/48 | 43/48 | 43/48 | 43/48 | 43/48 | 43/48 | 43/77 | 77 | 77 | | |
| 28 MPa / 4,000 psi | 43/48 | 43/48 | 43/48 | 43/48 | 43/48 | 43 | 77 | 77 | 77 | | |
| 35 MPa / 5,000 psi | 43/48 | 43/48 | 77 | 77 | 77 | 77 | 77 | 77 | 77 | | |
| 42 MPa / 6,000 psi | 43/48 | 43 | 77 | 77 | 77 | 77 | 77 | 77 | 77 | | |

High Performance

Because challenges can emerge anytime and anywhere, your solution should endure the tough conditions of your work environment.

The high-performance standards designed, engineered and manufactured into GlobalCore provide the longest service life possible.

With GlobalCore hoses tested to twice the ISO 18752 standard, high performance in rugged environments and high-impulse applications is ensured.

Additional value is realized through:

- 100 °C / 125 °C temperature ratings
- Standard, ToughCover and SuperTough cover technologies for abrasion resistance
- ½ minimum bend radius (beside hose 187)
- Low force to flex for ease of installation
- Advanced inner tube chemistry



Any Pressure. Any Project. One Solution.

Cohesive

GlobalCore is a unified system that delivers hoses designed, built and tested to the ISO 18752 specification. GlobalCore expands our range of ISO 18752 hoses and provides options for the most critical sizes and pressure ranges – 7.0 MPa (1,000 psi) to 42.0 MPa (6,000 psi) in sizes -4 through -48.

Simple

The GlobalCore system is simple. With only six hoses, OEM and MRO customers alike will enjoy selecting the right hose based on working pressure. Selecting the fitting is even simpler. Choose the world renowned 43/48 Series, with more than 2,500 configurations, or the 77 Series, designed specifically for higher pressure applications and available in more than 500 configurations.

Cover Options

GlobalCore hoses come with a variety of cover options so you can match the right cover to your application.



Standard



Tough



Super Tough

Global

A single cohesive family of complimentary products so qualified has never before been offered globally. Produced with the same performance and manufacturing specification in production plants located in all the continents, GlobalCore can support your hydraulic hose needs regardless of where your equipment was originally manufactured or is today.

Global Approvals

GlobalCore will carry the most common international classification body type approvals as requested by our customers. ABS, DNV, Lloyd's Register, MSHA and USCG will be comprehensive approvals, while other certifications will be specific to designated hoses or sizes.



Visit parkerglobalcore.com for the latest list of hose and classification body type approvals.



It's so easy to crimp your own hose assemblies whenever you need them

Parkrimp® *No-Skive*

The system for fast and leak-free hose assemblies with No-Skive one-piece fittings

Hose fittings have an impact on the overall efficiency and safety of a hydraulic system. The No-Skive concept was launched by Parker Hannifin some 30 years ago but continuous development and the use of modern materials and production techniques have resulted in a state-of-the-art hose to fitting connection. Much easier handling and a high level of safety are available with No-Skive crimp fittings. Parker offers No-Skive fittings in one and two pieces as part of a package consisting of quality hose, No-Skive fittings, hose crimpers and tooling.

- No skiving tool needed
- No need to remove the cover
- Crimps one-piece fittings
- Parkalign positions the fittings in the dies perfectly every time
- Quick and easy – no gauges to set on the machine
- Portable machines for field repair
- Meets EN safety regulations



KarryKrimp® 1
82CE-061L



KarryKrimp® 2
85CE-061L



Parkrimp® 2
83CE-083U

Modular crimpers with bench power unit for workshops

The modular design enables the customer to choose between the portability that Parker KarryKrimp crimpers have always offered, and the option to make these same crimpers bench mount units.

In addition to the portable versions, the sole crimping units can be used with the Bench Power Unit for workshop versions for faster cycle times, increased productivity and increased height for longer elbows or bent tube fittings.



KarryKrimp® 2 Bench Mount
85CE-061L + 85CE-1PE

Please visit us also at
www.easy-crimping.com



ParLock – the complete Big Bore solution

No-Skive™ and ParLock Skive technology

In addition to the new R35TC-40, already launched and very well accepted in the market, Polymer Hose Division Europe follows its strategy to develop a complete Big Bore hydraulic hose range. Four different hose types are available to fulfil all high flow rate hydraulic needs for markets like oil & gas, mining and heavy duty constructions.



R35TC-40 and RS35TC-48

R35TC-40 and RS35TC-48

- Very high working pressure of 35.0 MPa (5000 psi)
- High abrasion resistant **TOUGH COVER** prolongs hose life, minimizes downtime and eliminates extra cost for additional protection sleeves – MSHA approved
- Approved with Interlock V6 series fittings, connection types: ISO 6162-2 (42.0 MPa/6000 psi)

R35TC-40

- Design factor of 4:1
- Impulse tested to more than 1.5 million cycles at +120 °C
- Extra strong 6-spiral construction for high-flex-impulse and high-vibration applications
- **NEW:** ISO 6162-2 (42.0 MPa/ 6000 psi) flange

RS35TC-48

- Design factor of 2.5:1 according ISO 6708-D
- Extra strong 6-spiral construction for high-vibration applications

For heavy duty applications, both sizes -40 (63.5 mm) and -48 (76 mm), based on Interlock technology, will complete the existing ParLock range and is now available from size -4 to -48.

Due to the severe applications, both hoses are coming with TC cover for best abrasion resistance and MSHA approved. Due to the enhanced hose diameters and in combination with very high pressures, flow rates can be increased – this eliminates the need of numerous pressure lines and results in a cost reduction for connectors. Today, all 6000 psi flanges are available and SteckO® fittings can be used for mining applications.



462TC-40/462TC-48

For low pressure and return lines, Parker extended the very well known Elite Compact range with the new 2SC hose type 462TC – available **now** from size -4 to -48.

In order to reach a 7.0 MPa working pressure with Elite Compact hose 462TC in both sizes -40 and -48, Parker developed a brand new Big Bore fitting which will complete the well known 48 series.

462TC-40 and 462TC-48

- No-Skive hose construction – Compact design
- Nitrile (NBR) inner tube – extended fluid compatibility
- Exceeding EN/ISO specifications for pressure, bend radius and abrasion resistance
- Highly abrasion resistant **TOUGH COVER**, MSHA approved
- WP 7.0 MPa with 4:1 design factor – Dynamic application, impulse tested
- High flexibility in spite of big size
- 2piece fittings for use with adjustable crimper only (47 series nipple and 10048 shell)

Hoses for the Oil & Gas market

Quality, reliability, consistency and service!

The Parker blowout preventer (BOP) hose system is a vital part of exploration and drilling equipment in the very demanding oil & gas market. Optimum performance with the highest safety is the main aspect. Especially the high quality compounds of BOP hoses such as ParLock FA35 – all made in Europe – and the assembly process of the components guarantees our customers the highest flexibility and the easiest installation on site. Parker BOP hose system has been tested and approved according to API 16D standard by Lloyds Register. The BOP hose system is supplemented by a wide range of hoses and fittings for rotary drilling application, e.g. hose types RD35TC and CEM69TC.

CEM69TC is a multispiral hose with six spirals and dedicated for cementing hose applications with flexible connection between the cementing pump manifold and cementing head for conveyance of cement slurries at high pressure up to 69.0 MPa. CEM69TC is tested and approved by DNV according to API 7K.

RD35TC – Rotary drilling hose available in sizes -32, -40 and -48, designed to work at 35.0 MPa constant working pressure with fluids made of mud, cement and oils used in various drilling operations. DNV has certified the compliance of RD35TC range to API 7K grade D, FLS2 specification.



FA35 is a hose range from size -10 to -32 with constant working pressure of 35.0 MPa, used in a very delicate hydraulic circuit that operates the blowout preventer security mechanism to shut down the well in case of need.

FA35 has successfully passed very tough flame test of API 16D (hose under 35.0 MPa exposed for min. 5 minutes to flame 700 °C) and has been certified by Lloyd's Register according to this norm.

All these certified matching systems, let you work safer, smarter, faster and better.



Parker Blastopak

New hose range for water-blasting applications

Choose the improved performance of Parker Blastopak hose

Parker's Blastopak range is an offer of hoses with four or six spirals that better meets the requirements of water-jetting and blasting applications. High-pressure water-blasting hoses are widely used for many industrial applications like water cutting, cleaning and removal of corrosion or paint or other kinds of materials.

In water-blasting applications, ultra-high pressure systems are commonly used, where the safety and robustness of a product are essential.

Parker's range of Blastopak hoses is the ideal solution for these kinds of applications. With its high working pressure from 800 bar (80 MPa) in size -16 up to 1100 bar (110 MPa) in size -6 to -12, good flexibility combined with dedicated interlock fittings is the right choice to ensure better performance and safety at the same time.

Design factor burst/working pressure of 2.5:1; the product meets the requirements of global specification DIN EN 1829/2 (impulse) in all common hydraulic applications.



High-performance PU-cover rubber hoses

The fusion of two worlds in one

Parker rubber hoses with polyurethane cover – the range for the future with outstanding properties

With hoses 462PU, 692PU and 837PU-Plus, Parker has realised the combination of synthetic rubber and polyurethane. Due to the manufacturing process and the two materials, these hoses reach new dimensions in terms of quality and product properties, e.g. a design factor of 4:1 for 462PU and 692PU.

462PU

Type 462PU is a compact, medium pressure hydraulic hose with two steel wire braids and a working pressure from 28.0 MPa up to 42.5 MPa.

Types 462PU and 692PU have been specially developed to meet the challenges of over-the-sheave applications of twin hose. This is why their main applications are forklift masts, telehandlers and materials handling equipment.



692PU

Type 692PU is also a compact medium pressure hydraulic hose with one or two steel wire braids and a constant working pressure of 21.0 MPa.



837PU-Plus

Type 837PU-Plus is a low pressure Push-Lok hose with a braided reinforcement made of high-strength textile fibres. The preferred applications of type 837PU-Plus



include cooling circuits and compressed air in hose bundles and energy chains of robots, car production lines, machine tools, injection moulding and PET blow moulding machines.

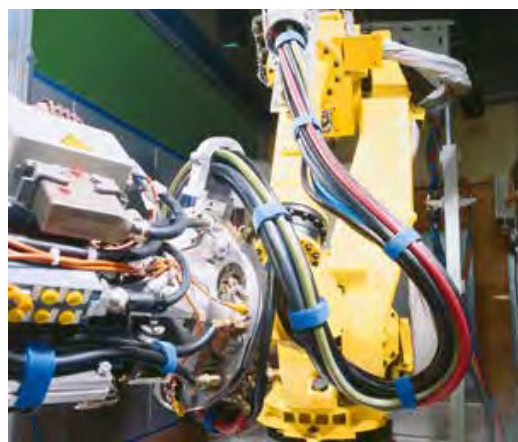

Parker rubber compounds

assuring superior ozone resistance and performance

Ozone – O₃

A molecule consisting of three oxygen atoms is called OZONE (O₃). In the ozone layer this gas protects living organisms against harmful UV-radiation, but also it is a strong oxidant, harmful against the respiratory system of humans and animals.

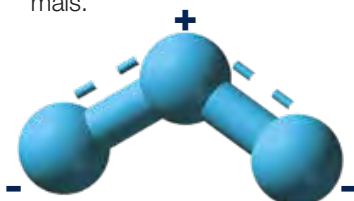

Ozone is highly impacting the degeneration of rubber

Ozone is one of the strongest oxidants. Beside the harms to all organic material it also applies to elastomer compounds, e.g. NBR, CR. Already small concentrations impacting product quality and service life. Moisture intensifies ozone cracking.

The concentration of ozone is rising

Ozone is generated by UV-rays, electrical discharge and air pollution. The natural ozone concentration is highly influenced by local conditions. Since 1971, the beginning of ozone measurements, the values continuously raised by 30% up to now.

Ozone resistance is a must

The polymer chains are split by ozone, leading to cracks growing vertical to the direction of elongation. Even a small amount of elongation (≤10%) is required to provoke cracks and increases rapidly with increasing elongation. The cracks, finally reaching the reinforcement of the hose, will cause corrosion and ending up in severe damage. In order to increase hose life, Parker

developed a new series of rubber compounds for Standard cover, Tough cover (TC) and low temperature (LT) hoses.

Parker Elite and multispiral hoses are able to withstand more than **400 hours** 400 hour ozone resistance, following the ISO7326 Ozone Resistance Test. Super Tough (ST) cover hoses pass even more than 800 hours ozone resistance.



ISO 7326 Ozone Resistance Test

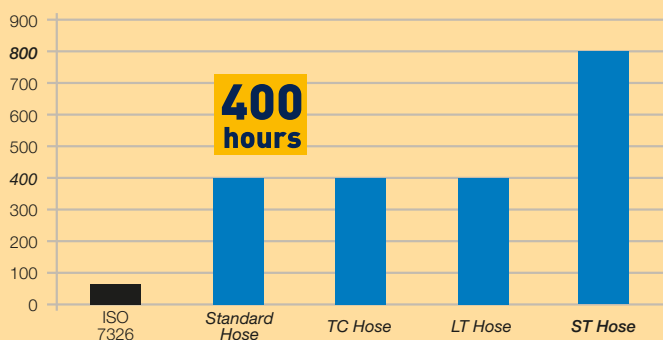

Attention

Ozone resistance is highly influenced by the bending radius (short bend radius = less ozone resistance)

Additional environmental conditions such as chemicals and temperatures may also shorten the hose life!

If your application requires corrosion resistance

state of the art surface protection for hose fittings is the solution

400 hours

Our mandate for continuous improvement leads us to partner with our customers to create smaller, lighter, sustainable, more energy efficient and finally highly reliable solutions. Our goal is thus to provide you with state of the art surface protection for

our standard hydraulic hose fittings in order to withstand the world's most demanding application requirements.

In terms of corrosion resistance properties, we decided to follow the needs of our customers and the market and chose improved red corrosion resistance four standard hose fittings.

Parker hose fittings with our chromium 6 free standard plating show a red corrosion resistance of at least **400 hours** of salt spray in a test carried out in accordance with DIN EN 9227.

Chromium-6
Free

Fittings with XTR coating for extreme resistance to corrosion

720 hours

An outstanding advantage for equipment used in highly caustic applications and environments, are Parker fittings with XTR (Extreme-Resistance) coating. This coating withstands corrosion more than seven times longer than the SAE standard of 96 hours. In fact, Parker's proprietary

formulation has been tested to resist corroding for more than **720 hours**. In addition, Parker XTR coating is compliant with environmental restrictions worldwide, including RoHS, ELV and REACH.

Parker products with XTR coating guarantee all the leak-free performance and installation advantages that our customers expect. If your

application requires highly-resistant coating, you can order hose fittings with the extension "ZJ" e. g. **1C348-12-12ZJ**



For special applications in demanding environments stainless steel is the preferred selection

For pneumatic and hydraulic applications in demanding environments, your connection requirements will be met by Parker's range of stainless steel products. Parker offers a complete system of stainless steel products

such as tubes, tube fittings or 1- or 2-piece hose fittings for low, medium and high-pressure hydraulic hoses – everything from one source and approved by well known international classification bodies. It goes without saying

that Parker's stainless steel components are produced using superior quality stainless steel grade 1.4571, 1.4404, or 1.4401. Thanks to their resistance to corrosion and acids, all components are suitable for tough environments. However, some special applications require special materials and here you can rely on Parker as well – we have the resources to produce customised hose fittings for even the most demanding customer requirements.

Power in Stainless Steel

- Premier customer service
- Single-source solution
- Worldwide availability
- Customized products
- High-quality stainless steel materials
- Complementary design of tube & hose fittings



PTS

Parker® Tracking System

Increasing the speed, timing, and accuracy of your next service event.

Parker Tracking System (PTS) is an innovative component-tagging and asset management solution offered by Parker and our business partners in over 62 countries worldwide. Today's equipment and machines are more connected than ever before and harnessing this complex data is key to maximizing up-time. By focusing on critical-wear components, Parker drives new levels of productivity, efficiency, and reliability.

Uptime is Everything

Record, manage and retrieve critical asset information with PTS. This innovative system provides fast and accurate product information, speeding replacement regardless of where or when the original component was created. Because tagged products can be replaced sight unseen, PTS eliminates the need to wait for removal before new parts can be acquired. Reducing transaction time, means users can realize significant gains in productivity and equipment uptime.

Business System Integration

Maintenance, Repair and Operations (MRO) can be greatly enhanced by customizing PTS and integrating it into existing systems. With seamless data integration, Parker enables bi-directional transfer of critical data to maximize asset visibility and performance. For details on supported platforms and protocols, contact a member of our team.

Global Power, Local Reach

PTS works seamlessly around the world. Whether you sell, service or operate products and equipment in one city, one state or worldwide, PTS can be tailored to your needs. Equipment built in one country that is sold and serviced in another can use PTS to deliver accurate product details wherever and whenever they are needed. To support our global footprint, PTS offers translation in multiple languages.



How can something so small do so much?

PTS tags can be customized by the user to contain specific information.

The barcode speeds up the product identification and is about the mobile App controlled.

Every record contains a date code which can drive warranty, inspection, and maintenance activities.

Each asset is tagged with a unique PTS ID number which always guarantees a simple and accurate replacement.



Save valuable time



Parker Tracking System

www.Parker.com/PTS

PTS Mobile

Parker® Tracking System

Advanced asset management...on-the-go!

PTS is one of the industry's most comprehensive and widely distributed asset-tagging and tracking systems, and the PTS Mobile app is the perfect jobsite companion. With millions of tagged assemblies worldwide, you're only a few clicks away to a faster, easier, and more accurate replacement experience.

With You Wherever You Go

Identifying, servicing and replacing critical assets can be a frustrating process. Lost or outdated manuals and complex installations can make identification difficult and time-consuming. Usually, the only solution is to remove the product and take it to a distributor for a replacement. PTS makes getting replacement components fast, easy, and exact. And now that convenience is available wherever you go with the PTS Mobile app.

Available on Popular Platforms

PTS Mobile is available for Apple and Android devices. Just complete the brief registration form, or log in with your existing PTS credentials. PTS Mobile can also be paired with our OEM or Enterprise application to provide a complete asset management solution for your operation.



Quick Access

Use the new dashboard to get quick access to all of PTS Mobile's most important features.



Registration

Use PTS Mobile to register a growing number of Parker Hannifin products.



Asset Details

PTS Mobile gives complete details for registered products, and resources to locate distributors.



Where to Buy

PTS Mobile provides mapping and directions to nearby distributors using your smartphone's GPS.



PTS

Parker® Tracking System

Track and manage assets with ease

PTS Pro is our most capable offering. PTS Pro brings together advanced asset tracking/management capabilities with Parker's global network of distributors and service partners to provide comprehensive asset management solutions.

Fix When Fail is not a Strategy

Managing equipment or machinery maintenance can be a challenge for even the most capable and well resourced organizations. With hundreds or thousands of individual parts or components that require maintenance, keeping detailed records or maintenance logs can be a burden.

Most asset management systems do not break capital assets down into the detailed components that comprise them. PTS can help.

Global Service Partner

Parker employs a team of dedicated support staff worldwide. Through more than 13,000 service partners and OEMs, Parker can work with customers to provide advanced, on-site audit and maintenance planning services.

This service including:

- On-site asset identification and tagging
- Inspection, maintenance, and replacement
- Site or computer-based training programs



Asset Location

Establish detailed location data for fast and easy replacement.



Asset Inspection

Collecting and storing customizable asset inspection data for easy retrieval.



Scheduled Events

Easily schedule and manage future inspection and replacement dates.



Registration

Register PTS tagged products from our Mobile App.



Asset Genealogy

Capture and analyze asset replacement and service history for continuous improvement.



Transfer Records

Seamlessly transfer record visibility between multiple PTS accounts.



Export Details

Quickly export customizable asset reports into Microsoft Excel.



Databooks

Create professional PDF reports containing asset details, service history and attached files.



Digital Documents

Publish and access a variety of digital documentation.



Email Notifications

Receive personal Maintenance, Repair and Operations (MRO) email notifications.

Preventive Maintenance Program

Be preventive ... not reactive!

Hydraulic hose assemblies are essential components in hydraulic systems and each hose assembly will eventually fail: it's just a matter of when!

Broken hose assemblies often cause loss of earning, downtime and serious personal injuries.

Avoiding failures, losses and risks is definitely your first priority.

Preventive maintenance is needed whenever your hose assemblies show:

- Damaged, cracked, cut or abraded cover
- Exposed reinforcement
- Cracked, damaged or corroded fittings
- Leaks in fitting, sweating hose cover close to fitting
- Kinked, crushed, flattened or twisted hose
- Hard, stiff, cracked or burnt hose
- Blistered, soft, degraded or loose cover
- Fitting slippage on hose

Despite that, hose assemblies are generally underrated overlooked during machine servicing and the need of their preventive maintenance and timely replacement is ignored. This is simple a fact which we can hardly change. But what we can do, however is to help you to provide a hose assembly in the right place and at the right time whenever and wherever you'll need it.

As there are countless factors influencing the hose life, there cannot be and are not any exact guidelines to determine when a hose assembly has to be replaced or to judge how long it will work.

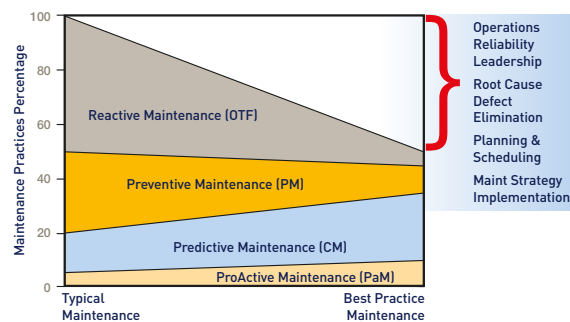

Hint

A good analogy is automobile tyres. Just like hose, tyres are made of rubber, age with time and experience a lot of strain from the conditions they work in. Most drivers are cautious to replace tyres once they show signs of wear, not leaving it to destiny when they break on the road! So why don't they do it with hydraulic hoses?

Yet, we do have a tool to influence and determine the hose life:

**Visual Inspections + Preventive Replacement
= Preventive Maintenance Program!**

Save valuable time



www.Parker.com/PTS

We offer more

Parker Rapid Service Unit

Non standard and customized hose fittings

The Rapid Service Unit (RSU) can provide:

- Jump sizes
- Specific end configurations
- Specific drop lengths
- Fitting/tube combinations
- Customised prototypes
- Any batch size upwards from a single piece

Material options include steel, stainless steel, brass and special materials on request.



*Hose Fitting Design
Center of Excellence*

*Flexible brazing in terms
of design and process*

The Rapid Service Unit (RSU) is part of the Manufacturing Unit Fittings of Polymer Hose Division Europe and is a dedicated unit for the manufacture of customised and prototype hose fittings.

The unit is responsible for both checking the technical possibilities of the customer request from an engineering perspective as well as establishing the most economic production process. Because of close cooperation between Parker's Manufacturing Units and the Parker Sales Companies (PSC) the Rapid Service Unit (RSU) can live up to its name by reacting, quoting and supplying rapidly.

After receiving the order, the RSU team will promptly and carefully process the order – from its receipt to the shipping of the fittings. For the production of such fittings, we have dedicated resources in a state-of-the-art manufacturing cell with CNC machinery and tools.

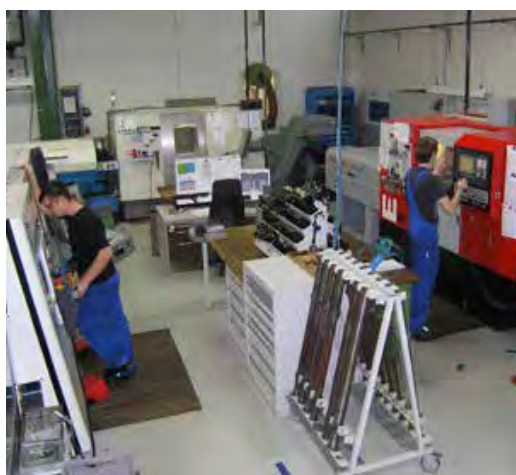

*24 Hours Turn-Around Capability
with access to 19 modern CNC*

We offer more

Where corrosion resistance is vital,
we have the best solution in stainless steel

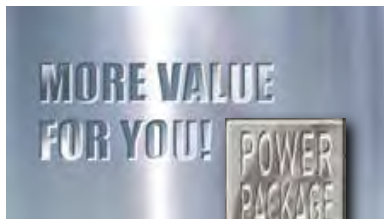

For more information about Parker's Stainless Steel Products please refer to our catalogue 4400.1 "Hydraulic Hose Fittings in Stainless Steel"



Mining hose, fittings and equipment



Parker's mining hoses, fittings and adaptors provide a complete, reliable hydraulic package to connect and support the mining equipment. All Parker mining hose products combine international approvals with total system integrity and long service life in hostile conditions.

Special coatings and carefully selected materials ensure reliability in corrosive environments.

For more information about Parker's Mining Products please refer to our catalogue 4410 "Mining Hose, Fittings and Equipment"



We offer more than just innovative products and solutions

We're constantly updating our customer service options to help you work smarter, faster, and better.



Parker offers concrete knowledge of respective products where selection criteria, scope of application and breadth of operation are invaluable. It is the goal of Parker to offer the possibility to our customers to always acquire and regularly refresh this expertise for daily implementation. In this respect, Parker's Polymer Hose Division Europe extensive training program offers valuable support.

The program incorporates product and target group training for acquiring not only basic knowledge, but also extensive familiarisation through practical experience with the products, incorporating identification and demonstration of application-specific operational advantages. To ensure that all participants enter the classroom with a fundamental product knowledge, Polymer Hose Division Europe has developed a complete training concept, including a training sample case.

News for business

This training is ideal for an audience who is interested on all kind of hose products/business news and their benefits for the customers.

- In addition to the regular trainings we are also offering customised in-house training sessions.
- To support all training activities, a sample case with the part number **HPDE-SAMPLE-CASE** has been developed with a comprehensive product selection to
 - provide you the tools allowing you to run and lead training sessions
 - improve your knowledge of the Division and its products
 - improve your knowledge of the hose market

Hose assembly workshop training

In this training the participant will get familiar with all major aspects (facility + equipment/operational steps/safety requirements) to produce a proper hydraulic hose assembly. This training supports all activities around a certified hose workshop.

Qualified person – hydraulic hose technology

The participants will learn about international safety standards and requirements for hydraulic hose products. The training course includes guidance to select the right product depend on application conditions and Parker instructions to produce a proper hose assembly. The training will convey also knowledge about potential failure and aging affects and how to avoid them.



Part Number HPDE-SAMPLE-CASE

Basic product training

The scope of this training is for beginners in hydraulic hose business and helps to acquire basic knowledge about hose products incl. workshop equipment. The participant is able to identify all hydraulic hose products and to answer application related questions based on catalogue knowledge, the product range and production selection criteria.



Value Added Services

ParkerStore™

At Parker Hannifin, we're continually looking for ways to deliver more products, more efficiently.

The Global ParkerStore™ network enables Parker to provide

- Prompt, efficient, professional in-store services while you wait
- A safe, friendly and convenient shopping environment
- A greater range of parts options so you get exactly what you're looking for



Customers trust ParkerStores to provide OEM and MRO customers with direct access to

- Custom-made hydraulic hose assemblies and complementary products to support their applications and decrease their downtime
- Expert technical support
- Professional, personalized services, including 24/7/365 support
- The convenience, comfort and amenities of a local service provider.

ParkerStore™ Container Service



The ParkerStore container is a transportable workshop, providing on-site maintenance and product support for large construction projects such as roadworks, tunnels, railways, underground systems, etc. Provides an on-site product and hose replacement service. With this service on your site, you can reduce your downtime keeping your project on time and on budget!



Cargo Doors



Storage Racks and Cabinets



Full Electrical Service



Security Doors



Heating/Cooling



Rugged Lighting Service

HOSE DOCTOR®

Parker HOSE DOCTORS® are a network of independently-owned, mobile service technicians built around the commitment to identify and replace hose assemblies wherever their customers need them, with the fastest response times possible.

HOSE DOCTORS® are an extension of the worldwide Parker distribution network, coupling their service commitment with Parker products – the highest quality hoses and fittings available in the market today.



Value Added Services

Kitting

Multiple components are supplied under a single part number

- Reduced number of suppliers
- Reduced stocks and no obsolete items
- Optimized management (stock and supplies)
- Simplified and optimised order handling
- Reduced assembly costs
- Greater productivity



Tech Services

Optimises the performance of your hydraulic and pneumatic circuits

- With Parker Tech Services involved, your time to market is shorter, which saves on development costs
- The 3 year no-leak guarantee enhances your reputation and lowers your warranty costs
- More reliable operation lowers your customer's operating costs
- More efficient performance and no-leak guarantee is beneficial to the environment
- Parker worldwide coverage ensures you can use the service and save costs wherever you are



Breadman Vendor Managed Inventory

Lean logistics and delivery of Parker products and kits directly to the customer's assembly line, work stations or warehouse

- 100 % parts availability minimises downtime, increases production and reduces costs
- Elimination of stock checking reduces manpower and maintains production levels
- Daily delivery reduces inventory and overheads
- Electronic order processing eliminates paperwork and reduces administration costs
- Enjoy a customized program where Parker personal can manage your inventory in person or remotely
- Reduce overall inventory, increase your inventory turns and increase your efficiency

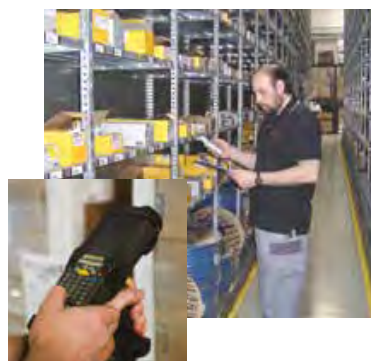

Whatever application you have we have the right solution

Polymer Hose Division Europe supplies premier customer service by focussing on customer needs and analysing the entire business environment in which our customers operate.

Our expertise spans the core motion and control technologies, and we apply it to make a meaningful difference in the lives of people everywhere. Parker can be found on and around everything that moves!

We engineer and manufacture high quality hoses and hose fittings to help our customers to achieve a higher level of profitability by considering

- our customers' needs and desires
- what hose and fitting technology our customers prefer
- how to advance customer's brand loyalty

By working with us, you have access to an integrated network of global manufacturing plants as well as sales and service offices in 50 countries.



Transportation



Military



Agriculture



Forestry



Utility Equipment



Machine Tool



Waste & Refuse



Marine



Ground Support Equipment



Mining



RV & Bus



Construction



Grounds & Building Maintenance



Railroad



Personnel Lift Equipment



Oil Field Service



Material Handling



Paving & Road Maintenance



Industrial



Inplant Automotive

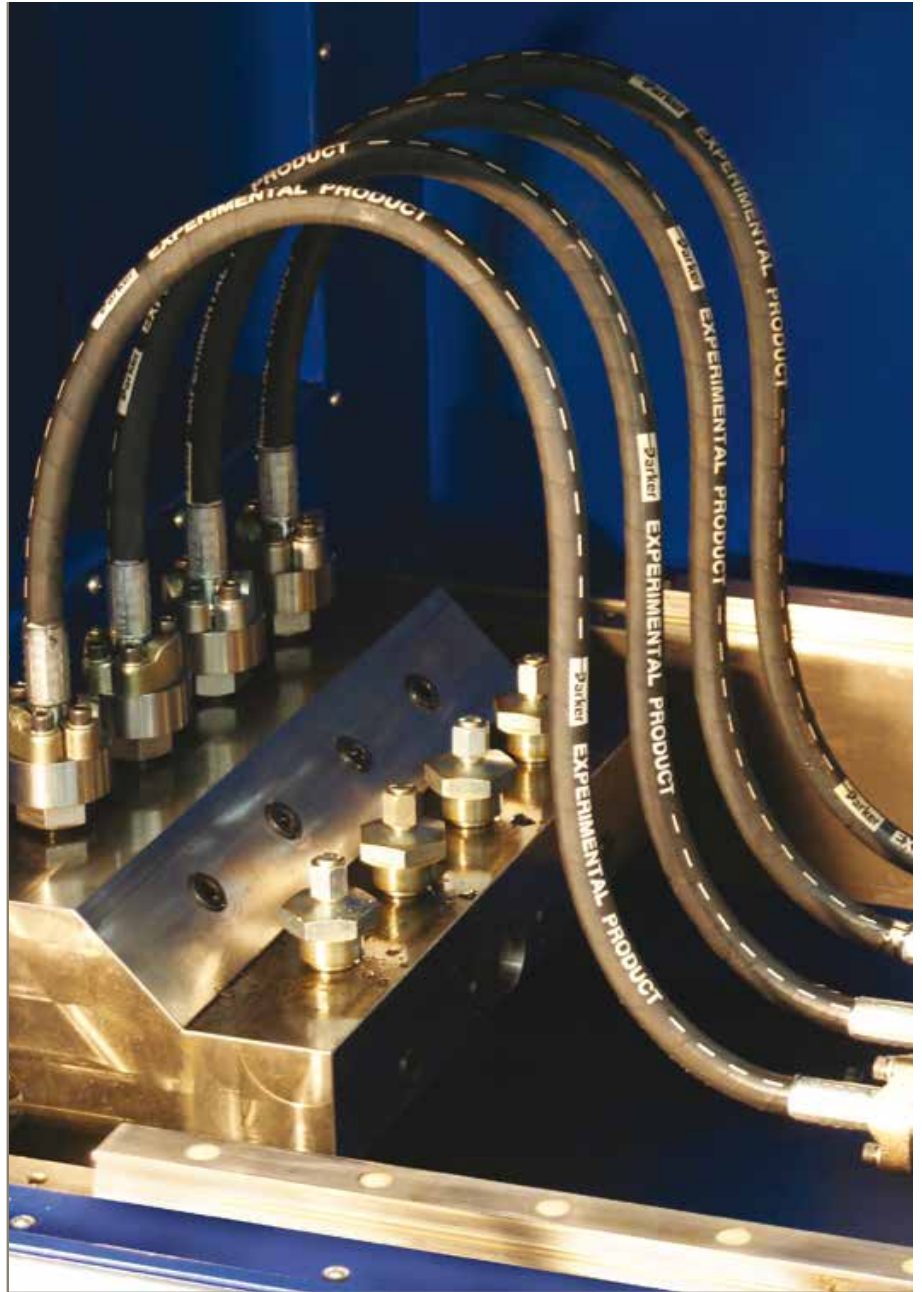

Hydraulic Hoses, Fittings and Equipment

Technical Handbook



ENGINEERING YOUR SUCCESS.

Crimp systems you can trust

Along with the ever-growing power and efficiency of each type of machinery and increasing working pressures and flow rates of their hydraulic systems, multispiral hose is gaining an increasingly important role in machine design. Parker Hannifin, as the world leader in the hydraulic hose market, responds to these highly demanding requirements with 3 comprehensive systems – Parkrimp No-Skive, Interlock No-Skive and Parlock Skive type.

Parkrimp *No-Skive* system

is based on no-skiving technology (without removing the rubber cover before assembling)



Interlock *No-Skive*™ system

for Compact Spiral™ hoses



ParLock system

uses external or internal and external skiving (Interlock) technology

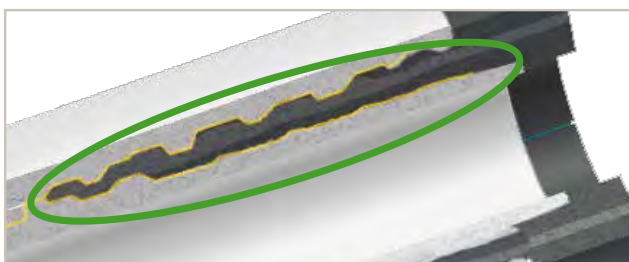

Each of the systems consists of integrated ranges of hose, fittings and assembling equipment and know-how, all of which are:

- Designed and developed together
- Tested and approved together
- Produced and supplied together

This way Parker Hannifin can guarantee:

- The highest quality and safety and the longest service life of the final product – to the end users,
- and at the same time:*
- The easiest, most efficient and safe production process – to the assemblers.

In this way Parker Hannifin also meets the requirements of SAE J1273 and ISO 17165-2, which pay particular attention to matching the hose with the fittings and to their compatibility proven by the manufacturer.

Parkrimp *No-Skive*

The easy to operate crimp system from textile to 6 spiral high tensile steel wire

Parkrimp No-Skive is synonymous with the best solution for assembling hydraulic and related hose and fittings from both the technical and the manufacturing points of view!

Throughout the progressive rubber and metal compression during the crimping process the reinforcement always remains intact. The meticulous design,

testing and manufacturing processes of Parkrimp No-Skive hose and fittings, combined with the approved crimping diameters provide an excellent mechanical connection between the hose and the fitting. This absolutely leak-free connection gives long service life even with the highest pressures associated with 4- and 6-spiral hose assemblies.

The smartly designed and time-tested Parkrimp No-Skive assembling equipment combined with Parker's assembling know how allow the safest, most efficient and mistake-proof assembly process. The Parkrimp equipment allows cost and time savings to the assembler and guarantees a defect-free, reliable and durable final product to the end-user.

Parkrimp *No-Skive* hose and fittings

the system for fast and leak-free assemblies

- For crimping Parkrimp No-Skive fittings only
- No skiving tool needed
- No need to remove the cover
- Quick and easy: no gauges to set on the machine
- Portable machines for field repair
- Meets EN safety regulations

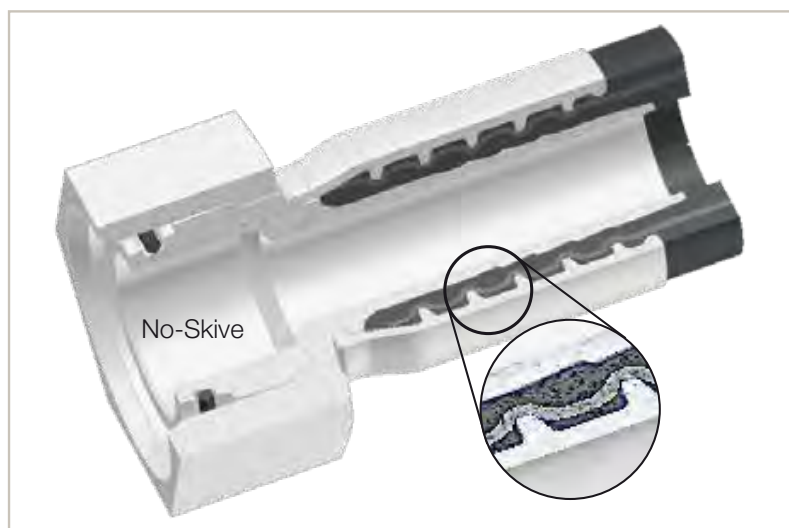

Parkrimp *No-Skive* hose and fittings the system with the perfect match



The perfect match

The complete system from one source. No-Skive hose, No-Skive fitting and crimping machine with world-wide guarantee and availability.



Parker's colour-coded die sets

No loose parts to mismatch or misplace – die set segments linked together. Die sets provide 360° evenly applied crimping forces for an ideal crimp result.

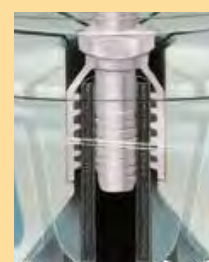

Parkalign®

Parker's exclusive Parkalign® positions the fitting in the dies perfectly every time.

Interlock *No-Skive*TM

The system for Compact SpiralTM hoses

For applications with extremely dynamic pressure profiles, pressure surges and peaks, as well as applications with intense vibrations and hose flexing (bending), especially when close to the fitting, a strong mechanical grip by the fitting onto the hose is paramount. A popular method accepted by the market of achieving this mechanical grip in such applications is to use hose fittings that „lock“ the metal reinforcement of the hose directly between the metal shell and nipple (a concept generally called „Interlock“).

As a response to the market requirement for an „Interlock“ hose fitting system, Parker has developed the Parlock and Interlock No-Skive program. This range consists of a specific range of hose, fittings and assembly equipment combined with Parker crimping know-how.

1piece No-Skive 77 series fitting covers the full range of sizes for both Compact SpiralTM hoses 787TC and 797TC hoses – designed to engage the inside of the tube into the spiral wire reinforcement

Parker's exclusive Interlock No-Skive design, with both internal and external „Bite the Wire“ technology for assured connection strength and for better hose to fitting connection which reduces leaks and increases holding power.

- Superior holding power
- Reduced „push- in“ force
- Smart sealing geometry to improve the cool down leakage performance
- Approved by the German DGUV (German Accident Prevention & Insurance Association) for applications requiring Interlock connection e. g. injection moulding machines (design standards EN 201).

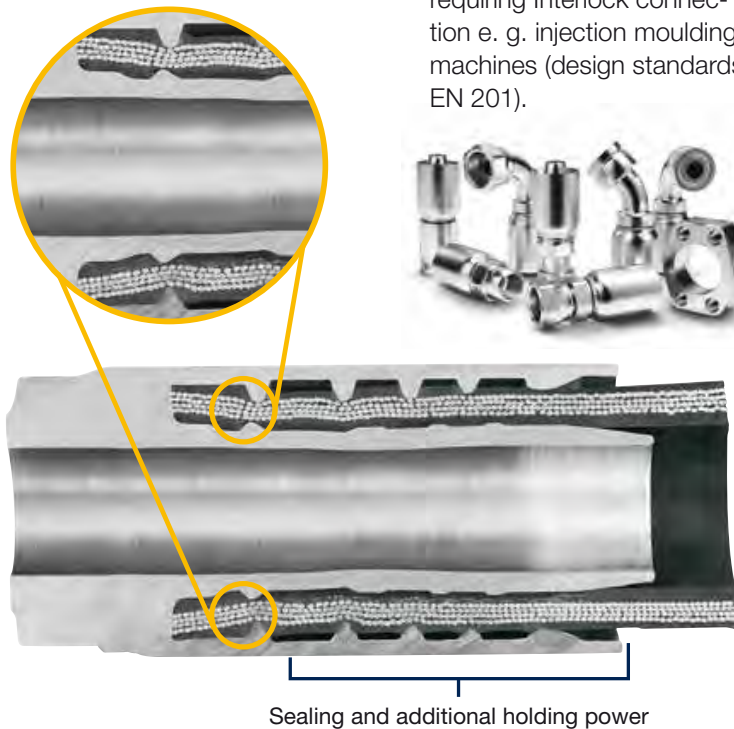

ParLock

The system for extremely dynamic pressure applications

Applications requiring the ParLock system

- Hydrostatic transmissions (combine harvesters, large tractors, excavators, etc.)
- Vibratory hammers
- Large injection moulding machines
- Tunnelling machines
- Forestry machines
- Large material handling machines (container handling)
- Excavator booms
- Blow-out preventers in oil and gas

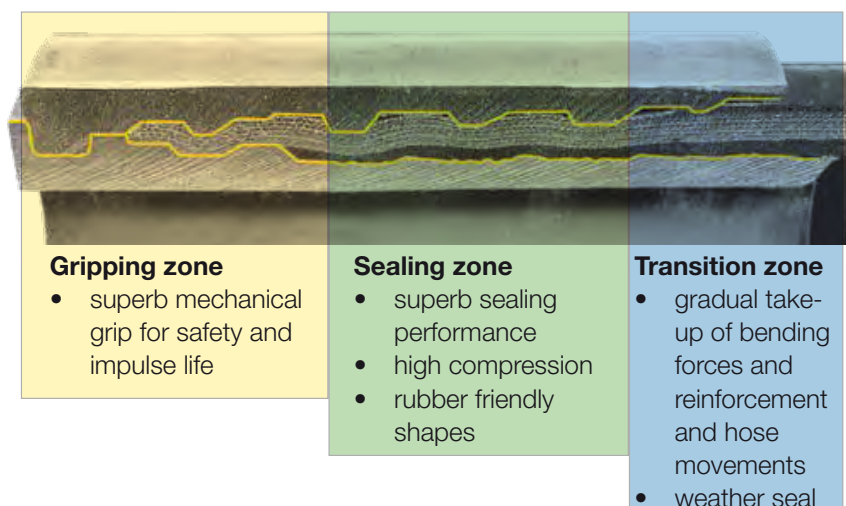

For manufacturing the ParLock hose assemblies Parker Hannifin offers

- Skiving machines for external and internal skiving
- Universal crimping machines with adjustable crimping diameter
- Detailed assembling instructions (see further in this catalogue)



A-5

Hydraulic hoses and fittings

| | |
|-------------------------------------------------------------|----------------------|
| Hoses and fittings terminology – the basics | Aa-2 – Aa-8 |
| Safe hose assemblies working steps | |
| 1 STAMP | Aa-9 – Aa-11 |
| 2 ASSEMBLY – 1piece Parkrimp No-Skive fittings | Aa-12 – Aa-14 |
| – 2piece ParLock fittings | Aa-15 – Aa-16 |
| 3 INSTALLATION | Aa-17 – Aa-19 |
| How to order (Part number description) | Aa-20 – Aa-21 |
| Identifying fitting types hoses and fittings | Aa-22 – Aa-29 |
| Storage | Aa-30 – Aa-31 |
| Safety first! | Aa-32 – Aa-33 |
| Parker safety guide | Aa-34 – Aa-38 |
| | |
| Technical data | |
| Hose overview | Ab-2 – Ab-4 |
| Hose fittings overview | Ab-5 – Ab-8 |
| Hose fittings pressure ratings | Ab-9 – Ab-11 |
| Hose fittings nomenclature | Ab-12 – Ab-15 |
| Classification bodies | Ab-16 |
| Approvals for Parker hydraulic hoses | Ab-17 – Ab-19 |
| Conversion chart | Ab-20 |
| Temperature and pressure chart | Ab-21 |
| Flow capacity nomogram | Ab-22 |
| The correct method to fit female swivel ends | Ab-23 |
| The correct method to fit ISO 6162-1 and ISO 6162-2 flanges | Ab-24 – Ab-25 |
| Chemical resistance table | Ab-26 – Ab-34 |

Hoses and fittings terminology

The basics!



Hydraulic hose is a full-value part of the hydraulic system transmitting the hydraulic power – not just conveying a fluid – and deserves adequate attention, just like the other hydraulic components which generate, consume or control that power. Furthermore, it is just hydraulic hose assemblies that are usually most exposed to various extreme conditions in which they have to retain full functionality and assure serviceability of the hydraulic system and safety of the operators.

In spite of that, the importance of the hydraulic hose is often overlooked and underestimated.

This catalogue is to provide guidelines to correct hoses and fittings selection and hose assembly manufacturing and to highlight the most important safety aspects for its service in the field.

Hydraulic rubber hoses

Tube – inner layer of rubber compound with chemical and physical properties to be long-term resistant to the fluid and working conditions.

Reinforcement – 1 or 2 (exceptionally 3) layers of braided textile fibre or highly tensile steel wire or 4 or 6 layers of spiralled very highly tensile steel wire to bear high pressure but allow flexibility of the hose.

Cover – outer layer of rubber compound with chemical and physical properties to protect the reinforcement against ambient conditions and mechanical damage.

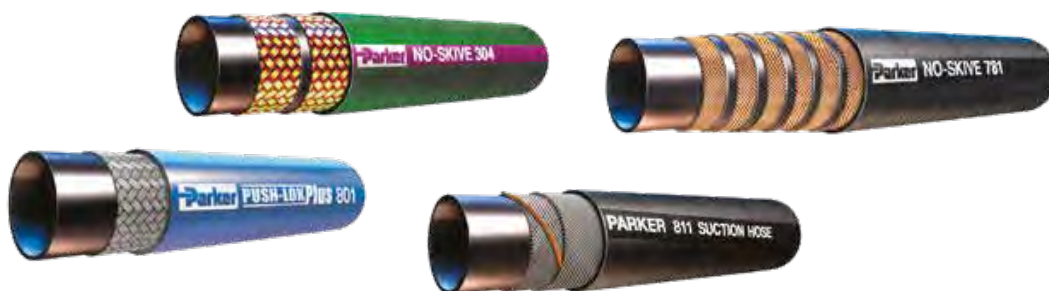
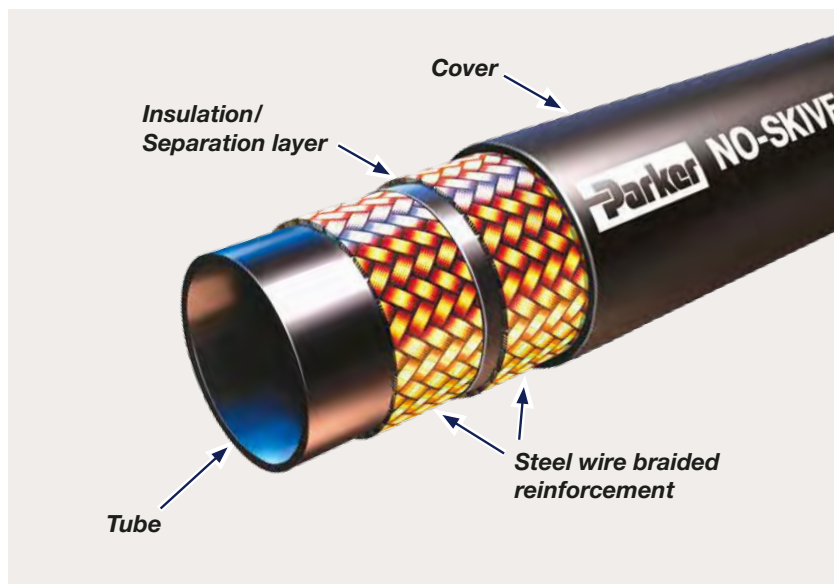

Depending on the pressure level we classify the hydraulic hoses in this catalogue into 4 groups:

- **Push-Lok**
 - low-pressure hoses with self-grip connection to fittings
- **Low pressure and Transportation**
 - 1 and 2 textile yarn braided and 1 steel wire braided hoses
- **Medium pressure**
 - 1 and 2 steel wire braided hoses and suction hoses
- **High pressure**
 - 3 steel wire braided hoses and 4 or 6 steel wire spiral hoses

Depending on the method of hose and fittings assembling we offer 2 basic product concepts (integrated product lines of hoses, fittings, assembling equipment and know-how):

- **Parkrimp**
 - complete range of braided and spiralled hose, not needing removing (skiving) of the hose cover before assembling.
 - Compact Spiral hose with patented internal and external “Bite the Wire” technology.
- **ParLock**
 - specific range of 4 and 6 spiral hose for extreme applications which require skiving of the cover and for bigger sizes also of the inner tube.

Hose fittings

Nipple (insert etc.) – the body of the fitting whereof one end is coupled to the counterpart of a hydraulic component (termination end), while the other end is inserted into the hose (tail end).

To assure compatibility with the counterpart, the designs of termination ends are specified by international standards.

The main role of the tail end is to provide durable sealing between fitting and hose.

Shell (socket, ferrule etc.) – the outer part of the fitting provides mechanical connection of the fitting with the hose. To assure a strong hold of the hose reinforcement, shells are generally crimped on to the hose during assembly.

The designs of tails and shells are not standardized but they are in the sole responsibility of the manufacturer.

Due to this reason fittings of various manufacturers are not automatically compatible with hoses of other manufacturers - unless the combination is fully tested acc. to the relevant international hose standards! This is also imposed by all international standards for hydraulic hose usage practices and fluid power systems safety!

In this catalogue we offer 3 kinds of fittings:

- **Push-Lok**
 - special nipples connectable to Push-Lok hose without any shells.
- **1piece fittings**
 - pre-crimped shells on nipples make the assembling of hose with fittings easier, more effective and reliable.
- **2piece fittings (for ParLock hoses)**
 - for extreme applications requiring full metal-to-metal connection of the hose reinforcement with the shell or even with the nipple (external or external plus internal skiving).
- **2piece fittings (for Parkrimp hoses size -40 and -48)**
 - for big bore applications
Please use adjustable crimpers only (47 series nipple and 10048 shell)



Note

Parker Hannifin also offers a limited range of 2piece Parkrimp No-Skive fittings but being special products they are not included in this catalogue. For more information about 2piece fittings, please contact our Division Helpdesk.

Note

Parker hoses have to be assembled with Parker fittings only! Crimping Parker hoses with fittings of other manufacturers may have serious impact on the hose assembly functionality and safety!

Except Push-Lok, all fittings in this catalogue are crimped and include:

- All Parker 1piece fittings
 - suitable for the **Parkrimp** product line
 - suitable for the **Interlock** product line
- All 2piece fittings in this catalogue
 - suitable for the **ParLock** product line and **Parkrimp** product line (size -40 and -48 only)



Hose assembly

It is the interplay between the fitting tail and shell designs and the hose design with its material properties that primarily determine performance, service, durability and safety of the final hose assembly. Yet compatibility of hose and fitting cannot be just theoretically projected. It requires exhaustive and repetitive laboratory and field tests and further tuning of the designs.

Non-compatibility of hose with fittings or combination of hose and fittings from different manufacturers, do not only influence performance of the hose assembly, they often lead to hose failure with serious health or life-threatening consequences! For this reason the main international standards for hydraulic hose usage practices and fluid power systems safety strictly warn not to mix hose with fittings from different manufacturers!

Parker Hannifin has not approved products of any other manufacturer for combination with Parker hoses and/ or Parker fittings and guarantees full compatibility, reliability and safety only for combinations of genuine Parker parts selected and assembled in accordance with the guidelines included in this catalogue!

Hose Hint

Never mix & match one manufacturer's fittings with hoses from another manufacturer! Parker hoses, fittings, assembling equipment and know-how are designed as an integrated system, guaranteeing the utmost product performance, reliability and safety!



Pressure rating

Hydraulic hose is a component transmitting hydraulic power and the pressure is obviously the main physical quantity determining the hydraulic power. For hydraulic hoses the following pressure ratings are used:

Working Pressure – the pressure for which the hose assembly is designed to operate over its whole service life - provided the other parameters (temperature in particular) stay within reasonable limits.

For apparently static applications (e.g. with hand pumps or water jetting) consult the Working Pressure with your Parker Field Representative or with our Technical Support.



Burst Pressure – the pressure which statically applied causes destruction of the hose. Technical standards for hydraulic hoses define the burst pressure to be equal to or higher than **4 times the working pressure** (design factor 4). This rule and the burst pressure in general serve to hose manufacturers for design and testing of the hose only! If you happen to know the burst pressure of certain hose, never use this rule backwards to deduce its working pressure!



Pressure rating

Remember the working pressure

1. The **hose assembly working pressure** is given by the weakest "link in the chain" - i.e. by the lowest of the working pressures of the hose and of both fittings. Do not forget to check the working pressure of the fittings when selecting components for a hose assembly (see pages **Ab-9** to **Ab-11** of this catalogue)!
2. The **real hydraulic system operating pressure** is not given by the system components setup but by the application which introduces into the system peaks and surges or by the functioning of the system itself (rapid closing or opening) which induces spikes and pulses. Such occurrences are detectable only by sensitive electronic pressure gauges and are usually not fully or not at all filtered out by safety or relief valves and exert excessive strain on the hydraulic system – hoses and tubes first of all!
3. **The hose assembly working pressure must always be equal to or higher than the real hydraulic system operating pressure incl. all peaks, surges, spikes and pulses!**

Hose Hint

Working pressure is a dynamic parameter, burst pressure is a static parameter. High burst pressure does not mean high working pressure!



Unit of measure

The most commonly used unit of measure for hydraulic pressure worldwide is MPa (Mega Pascal) – used also in this catalogue. In the US and in Anglo-Saxon markets also psi (pounds per square inch) is officially used and many European producers, users and even technical standards still also use bar.

For the conversion chart of various units of measure see page **Ab-20**.

In order to assure mutual compatibility, producers of hydraulic equipment, producers of machines and also international technical standards profess certain preferred pressure levels:

| MPa | 21 | 28 | 35 | 42 |
|-----|------|------|------|------|
| bar | 210 | 280 | 350 | 420 |
| psi | 3000 | 4000 | 5000 | 6000 |

Hose Hint

For highly demanding applications (dynamic pressure, high number of pressure cycles, high temperature etc.):

- Select hose with much higher working pressure than officially requested
- Select multispiral hose instead of braided or ParLock instead of Parkrimp No-Skive
- Select all of that in order to increase service life and safety!

Hose size

The other parameter determining the hydraulic power in direct proportion is the flow rate – i.e. the fluid velocity. However, too high fluid velocity gives rise to turbulence, pressure drops and heating up of the fluid, causing excessive ageing of hoses and other components or even their damage. To keep the fluid velocity below certain limits but achieve the required flow rate, the size of the hose has to be defined appropriately (see Flow Capacity Chart on page **Ab-22**).

As the first technical standards for hose came from the USA, dimensions of hose are defined in inches and hose sizes are expressed in inches or from inch-derived units. Global companies – such as Parker – use **dash sizes** (-1 = 1/16”), while the European standards use DIN-based DN (diameter nominal) sizes.



| dash | inch | DN | mm |
|------|-------|----|------|
| -3 | 3/16 | 5 | 4.8 |
| -4 | 1/4 | 6 | 6.4 |
| -5 | 5/16 | 8 | 7.9 |
| -6 | 3/8 | 10 | 9.5 |
| -8 | 1/2 | 12 | 12.7 |
| -10 | 5/8 | 16 | 15.9 |
| -12 | 3/4 | 19 | 19.1 |
| -16 | 1 | 25 | 25.4 |
| -20 | 1 1/4 | 31 | 31.8 |
| -24 | 1 1/2 | 38 | 38.1 |
| -32 | 2 | 51 | 50.8 |
| -40 | 2 1/2 | 63 | 63.5 |
| -48 | 3 | 76 | 76.2 |

Technical Handbook

Note

SAE 100 R5 hydraulic hose, SAE J1402 air-brake hose and SAE J2064 air-conditioning hose use sizes equivalent to corresponding metal tube I.D. – different from the other hydraulic hoses (see datasheets of these hoses in this catalogue).

| Size | Inch | mm | DN |
|------|------|-----------------------|----|
| -6 | 6/16 | $6/16 * 25,4 = 9,525$ | 10 |
| ↓ | ↓ | ↓ | ↓ |
| -6 | 3/8 | 9,5 | 10 |

Ambient and fluid temperature



Temperature is one of the factors which most negatively affect rubber characteristics and so it deserves particular attention of the hydraulic system designers and hose users!

High temperature causes degradation of rubber and accelerated ageing of the hose – an effect which can be yet further intensified by the chemical impact of the fluid. That is why the upper temperature limits specified in this catalogue refer to the fluid temperature and why they differ for various media.

However, permanent or long-term use at temperatures close to the upper limit would considerably shorten the hose service life in any case and if it cannot be avoided the hose should be replaced more frequently once it shows first symptoms of deterioration (stiffness, hard cover and cracks).

Low temperature, on the other hand, affects mainly physical properties of rubber – making it more fragile – and so at extremely low temperatures hose being bent may crack in tube or cover which can cause immediate or later leakage, burst or reinforcement damage. As there are not many hydraulic fluids which flow at or below -40 °C, the lower temperature limits specified in this catalogue refer rather to ambient temperature below which the hose should not be bent or otherwise hit from outside (while staying passively in it does not cause serious problems).

Hose Hint

The combination of high temperature and high pressure reduces the hose service life. Pay attention to regular inspection of such hoses and their preventive replacement if the cover is brittle or cracked!

Hose bend radius



The role of hydraulic hose is to provide a connection of relatively movable parts of the circuit and so its bending is a natural state the hose is designed for. However, the layout of the reinforcement wire or fibre inside a bent hose **may** shift to less appropriate positions. The tube and cover are stretched and become thinner and so the pressure resistance of a bent hose considerably decreases. For this reason working pressure and bend radius are negatively interdependent parameters and the max. working pressures specified in this catalogue are conditioned by respecting the min. bend radii.

Hose Hint

Bend radius and bending force are two different things! Not even apparently "flexible" hose (with low bending force) may be bent below the min. allowed radius!

Recommended fluids

As the power transmitting – not fluid conveying – element, hydraulic hose should be first of all used for the primary applications and with the recommended fluids specified in this catalogue!

For low pressure applications with various non-hydraulic fluids see our catalogue **"4401 Industrial Hoses"**.

If for required higher pressure or for any other reason you cannot use industrial hoses, follow the instructions in this catalogue (pages **Aa-10** – Application, **Aa-11** – Media and **Ab-26 to Ab-34** – Chemical Resistance Table).

Safe hose assembly

Working steps

1 Before you spec it, STAMP it.



SIZE

Parker uses a system of measurement called Dash Numbers to indicate hose and fitting size. The dash number, or dash size, is the measure of a hose's Inner Diameter (I.D.) in sixteenths of an inch.

This measuring system of the inside diameter of the hose is universally used by the fluid power industry today. Don't know the hose size? Check the layline. If the original printing has worn off, the original hose must be cut and the inside diameter measured. Be sure to measure the overall assembly length and fitting orientation before cutting the hose.

The hose I.D. must be sized accurately to obtain the proper flow velocity. A flow that's too slow results in sluggish system performance, while a flow that's too high causes excessive pressure drops, system damage, and leaks.

Use the Flow Capacity Nomogram page **Ab-22** to determine the proper hose I.D. for an application's flow rate requirements.

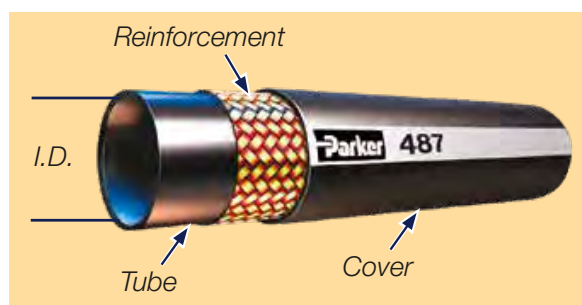

The hose size is determined by the inside diameter which can be measured or found on the layline.

Max. recommended fluid velocity:

- Pressure lines – ca. 6.1 m/sec
- Return lines – ca. 3 m/sec
- Suction lines – ca. 1.2 m/sec

Hose Hint

Don't try to save your own or your customer's money by downsizing the hose! It would cost your customer more to replace damaged hoses, other components and oil, and it will cost you more as you may lose your customer!

TEMPERATURE

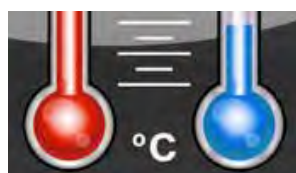

High Temperature

For high temperature hoses choose the part numbers ending in "6" – e.g. **436**

Low Temperature

For low temperature hoses choose the part numbers ending in "LT" – e.g. **461LT**

When specifying hose, there are two temperatures you need to identify. One is the **ambient temperature**, which is the temperature that exists outside the hose where it is being used; the other is the **media temperature**, which is the temperature of the media conveyed through the hose.

Very high or low ambient temperatures can have adverse effects on the hose cover and reinforcement materials, resulting in

reduced service life.

Media temperatures can have a much greater impact on hose life. For example, rubber loses flexibility if operated at high temperatures for extended periods.

Parker hoses carry different temperature ratings for different fluids. For example, 611HT hose has a temperature range of -40 °C to +150 °C for petroleum-based hydraulic fluids. However for water, water/glycol, and water/oil emulsion hydraulic fluids, the range drops to a rating of up to + 85 °C. Air is rated even lower at up to + 100 °C.

Some media can increase or decrease the effects of temperature on the hose. The maximum rated temperature of a hose is specific to the media.

Working steps

S T A M P

APPLICATION

Before selecting a hose, it is important to consider how the hose assembly will be used.

Answering the following questions may help:

- **What type of equipment is involved?**
- **What are the environmental factors?**
- **Are mechanical loads applied to the assembly?**
- **Will the routing be confined?**
- **What about hose fittings – No-Skive or ParLock?**
- **Will the assembly be subjected to abrasion?**

Hose Hint

You do not always need additional sleeve to protect the hose against abrasion!

*Parker high and extremely high abrasion resistant **TOUGH COVER** and **SUPER TOUGH** versions with 80-times and 450-times higher abrasion resistance do the same, but better and cheaper!*

Sometimes specific applications require specific hoses. For example, applications where hoses will encounter rubbing or abrasive surfaces, would be best handled

by our family of abrasion-resistant hose with both Tough and Super Tough covers.

When application space is tight, bend radius is another important consideration. Parker offers a full line of hoses designed for one-half SAE bend radius at full SAE-rated pressures. We offer hoses with increased flexibility and smaller outer diameters enabling faster, easier routing in small spaces, reducing both hose length and inventory requirements. Industry standards set specific requirements concerning construction type, size, tolerances, burst pressure, and impulse cycles of hoses. Parker hydraulic hoses meet or exceed standards such as:

- **ISO (International Organization for Standardization)**
- **EN (European Norm)**
- **SAE (Society of Automotive Engineers)**
- **DIN (Deutsches Institut für Normung)**

Governmental agencies control additional standards for particular industries such as U.S.C.G. and ABS. You must select a hose that meets the legal requirements as well as the functional requirements of the application.

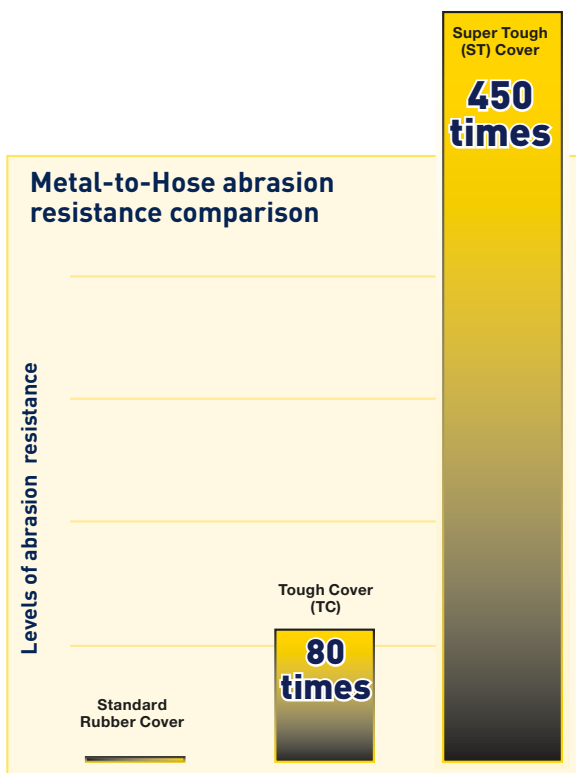

Working steps

S T A M P

SIZE TEMPERATURE APPLICATION MEDIA PRESSURE

MEDIA

What will the hose convey?

Some applications require the use of specialized oils or chemicals. The hose you order must be compatible with the medium being conveyed.

Compatibility must cover the inner tube, the cover, hose fittings, and o-rings as well. Use a Chemical Resistance Chart to select the correct components of the hose assembly that will be compatible with your system's media. The chart contains the chemical resistance rating of a variety of fluids.

See pages **Ab-26** to **Ab-34**.



Technical Handbook

PRESSURE

When considering hose pressure, it's important to know both the system working pressure and any surge pressures and spikes. Hose selection must be made so that the published maximum working pressure of the hose is equal to or greater than the maximum system pressure.

Surge pressures or peak transient pressures in the system must be below the published maximum working pressure for the hose.

Each Parker hose has a pressure rating which can be found on the hose table. All Parker hydraulic hoses have passed the industry rated specifications for burst pressure and carry a 4:1 design factor unless otherwise noted. Burst pressure ratings for hose are for manufacturing test purposes only. They are not an indication that the product can be used above the published maximum working pressure.

Care must also be taken when looking at the "weakest link" of the hose assembly. A hose assembly is rated at the maximum working pressure of the hose and the fitting component. Therefore the maximum working pressure of the hose assembly is the lesser of the rated working pressure of the hose and the end connections used.

Always check the fitting working pressure – see pages **Ab-9** to **Ab-11**.



Hose Hint

Although fittings are made of steel, their working pressure is often lower than that of hose!
Don't forget to check the working pressures of both fittings when selecting components for your hose assembly!

Working steps

2.1

ASSEMBLY 1piece Parkrimp fittings

Cutting

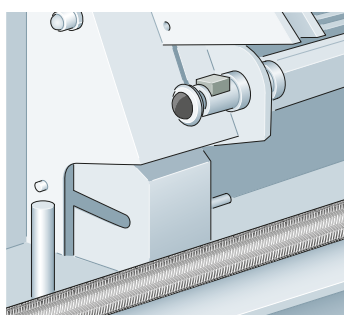

Hose is cut to the desired length according to specifications. The correct hose cutting tool ensures a square, clean cut without damaging the pressure reinforcement. Depending on the hose type, different kinds of cutting blades must be used:

- 1) Smooth cutting blade:
for high tensile textile layer, return line hoses and steel wire braided hoses
- 2) Serrated cutting blade:
for hoses with 4 or 6 spiral layer of high tensile steel wire

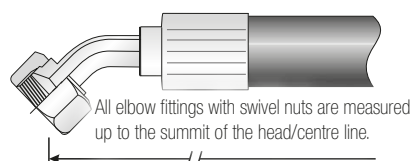
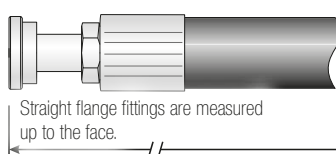
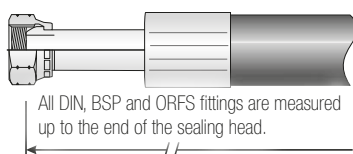
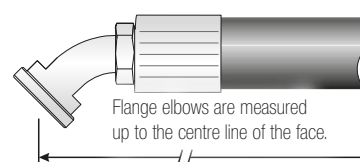
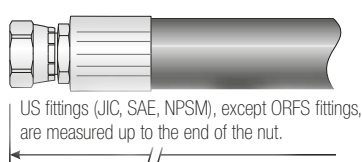
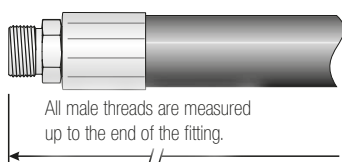

Tolerances for hose assemblies

Length tolerance according to DIN 20066 Tabelle 6

| Hose assembly length (mm) | Diameter (mm) | |
|---------------------------|------------------|-----------|
| | ≤ 25 | > 25 |
| up to 630 | +7 -3 | +12 -4 |
| over 630 up to 1250 | +12 -4 | +20 -6 |
| over 1250 up to 2500 | +20 -6 | +25 -6 |
| over 2500 up to 8000 | +1,5 % -0,5 % | |
| over 8000 | +3 % -1 % | |



According to EN ISO 4413, hose assemblies are not permitted to be manufactured from any components that have already been in use in other hose assemblies.

Cleaning after cutting

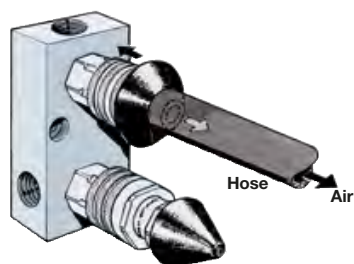

After cutting it is recommended to clean the hose with compressed air from both sides. Please make use of Parker's Cleaning System TH6-7 – A quick and simple system – Delivered with two plastic nozzles for hoses from size -4 up to -32. The hose is pressed against the nozzle and thereby opens a valve to allow the compressed air to blow through the hose and blow out loose particles.

Working steps

Marking

According to EN and ISO standards, hose assemblies must be clearly and permanently marked. They must bear the following information:

- Manufacturer's identification
- Date of production (year and month)
- Maximum permissible working pressure of the whole hose assembly

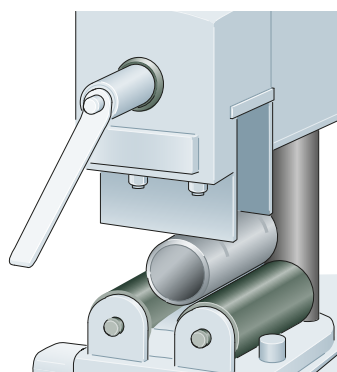

Crimping 1 piece Parkrimp No-Skive fittings

Crimping is the safest, fastest and most commonly used method of making a hose assembly. The Parker crimping systems ensure precise, leak-free and tear-proof assembly of hose and fitting. Reaching the exact crimping diameter is possible with Parkrimp crimping tools or adjustable crimping tools. When crimping, it is essential that hose, fitting and crimping tool (dies) match precisely. For crimping dimensions please refer www.parker.com/crimpsource-euro.

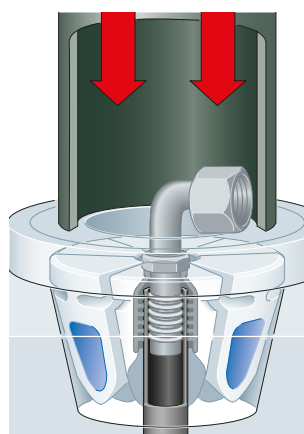

Furthermore, the insertion depth, a square cut hose, correct, burr-free and clean crimping are important to ensure a correctly formed and leak-free connection of hose and fitting. Using the Parkrimp hose crimpers or adjustable crimpers, the fitting is crimped onto the hose in one slow and smooth crimping procedure. A depth stop with automatic function ensures safe positioning of the fitting. This guarantees the correct crimping of hydraulic hose assemblies.



Find the correct crimp specification on the push of a button!

www.parker.com/crimpsource-euro

26, 43, 46, 48, 70, 73, 77 series:

Push the hose all the way into the coupling. Place the hose next to the fitting shell and mark the insertion depth or the length of the fitting onto the hose, push the hose into the fitting until the mark on the hose is even with the end of the shell. If necessary simply wet the fitting end with a drop of hose oil. Do not lubricate if using spiral hose.

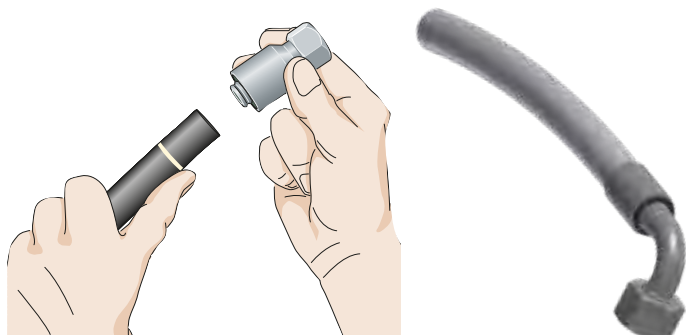

Angle setting

The displacement angle of a hose assembly is indicated only when two elbow fittings are assembled in a displaced way.

The angle always has to be indicated clockwise looking from the elbow fitting at the back to the one in the front. Please also consider the natural bending of the hose.

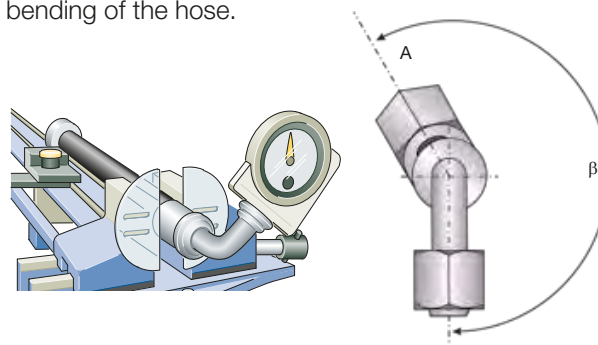

The hose assembly

Working steps

Testing (optional)

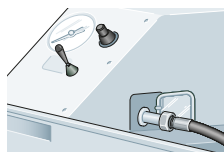

Static test pressure depending on the hose type and application is applied to the finished hose assembly for a pre-defined period of time. The test procedure can be documented using a test logging unit. The test pressure for Parker hydraulic hose assemblies is 2 times the value of the dynamic operating overpressure.

Proof pressure test

This test is typically carried out on customer request according to a method defined by the ISO 1402 standard. The test should be done at normal ambient temperature with a proof test bench using water or another suitable liquid. The hose assembly should be pressurised for between 30 to 60 seconds at twice the working pressure of the hose assembly. There should be no leakage or pressure drop. A complete test report should be provided together with the hose assembly to the customer.

Cleaning

Hydraulic systems have to reach a defined degree of cleanliness. To ensure that and to achieve certain cleanliness classes you can use different cleaning devices for a fast and efficient cleaning of hose assemblies.

The TH6-6 cleaning device first flushes the hose assembly with an anticorrosive emulsion and dries it afterwards with compressed air.



The dry-cleaning systems TH6-10-EL-7 or TH6-10-HL-9-2 fire a Ultra Clean projectile through the length of the hose assembly. In the end protect the finished hose assembly against impurities with plastic caps.

| ISO 4406 | NAS 1638 | SAE 749 |
|-------------|-------------|------------|
| 11/8 | 2 | |
| 12/9 | 3 | 0 |
| 13/10 | 4 | 1 |
| 14/11 | 5 | 2 |
| 15/12 | 6 | 3 |
| 16/13 | 7 | 4 |
| 17/14 | 8 | 5 |
| 18/15 | 9 | 6 |
| 19/16 | 10 | |
| 20/17 | 11 | |
| 21/18 | 12 | |



Working steps

2.2 ASSEMBLY 2piece ParLock fittings

Cutting, cleaning after cutting and marking
please see “Working Steps for 1piece Parkrimp No-Skive”

Skiving

For the skiving of hydraulic hose, one distinguishes between internal skiving and external skiving. This system is applied for hose types with 4 or 6 spiral reinforcement layers, the so-called Parker ParLock System or Interlock.

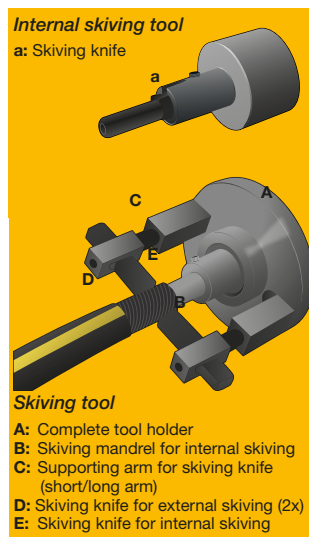

Adjustment of tools for internal skiving

Select the skiving tool according to the manufacturing documents and the hose size. Insert the knife for the internal skiving mandrel into the borehole of the mandrel provided for this purpose and mark it with a lock collar at the straight surface. When adjusting the knife, observe the marking on the internal skiving knife and insert the mandrel into the tool holder.



Adjustment of tools for external skiving

Attach the knives in the supporting arm. Select the supporting arm (long or short) depending on the hose size.

Adjust the knives according to the Parker working instructions and insert the tools into the machine. Push the mandrel onto the hose until it is close to the tool (external or internal skiving knife).

Adjustment of the sense of rotation of the machine

Always skive into the direction of the spiral layers. Please observe the operation instructions of the machine.

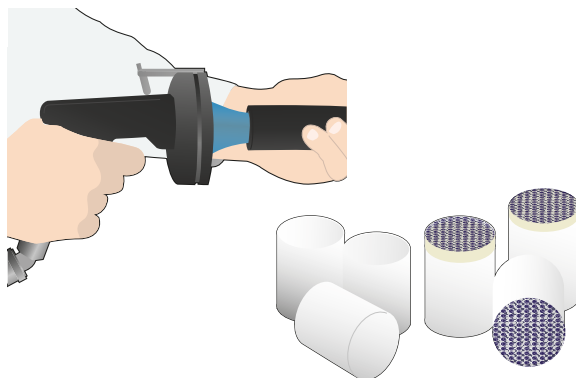

Cleaning after skiving

All hose types which have been skived externally or internally should be cleaned immediately after skiving. For this purpose we recommend using cleaning plugs which are shot through the hose using compressed air. (e.g. TH6-10-EL-8 or TH6-10-HL-10-2)

In addition to this working step, the finished hose assembly must be cleaned from both ends using pressurised air after the completion of this working step.

Working steps

Crimping 2piece ParLock fittings

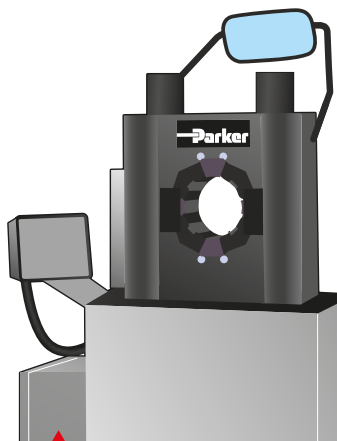

For crimping ParLock fittings V4 series a minimum of 320 tons crimping force is recommended. Min. of 340 tons for V6 series.

- 1) Select the appropriate crimping dies using the crimping diameter chart.
- 2) Before crimping hoses and fittings it must be ensured that you have the most recent crimping dimensions. For crimping dimensions please refer our crimp charts online at www.parker.com/crimpsource-euro
- 3) Insert the dies into the crimping press and set the crimping diameter.
- 4) Place the pre-assembled hose assembly into the crimper and perform the crimping procedure.
- 5) Please observe the operating instructions of the crimper.

! 2piece fittings must not be crimped on Parkrimp crimpers – only with adjustable crimpers.



Make sure that the hose ends are cut squarely. Push the ferrule onto the hose. The cut end of the hose must be clearly visible.



Push the nipple down into the hose until it reaches the stop on the lower groove (plastic ring, fitting shoulder or metal stop). Use Hoze-Oil, if required.



The ferrule must bottom up against the plastic ring or metal stop.

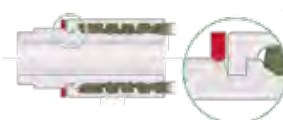

After crimping, the ferrule must be located precisely in the groove of the nipple.

Angle setting

please see “Working Steps for 1piece Parkrimp No-Skive”

Checking for the correct crimping diameter

In case of the ParLock System, the conicity is measured. It is measured at the beginning and the end of the ferrule in 2 measuring planes.

The conicity must be within the tolerance range specified in the Parker specification.



Measurement 1 in the plane of force



Measurement 2 displaced by 90°



Measurement 1 at the beginning and the end of the ferrule



Measurement 2 at the beginning and the end of the ferrule (displaced by 90°)



Testing and cleaning please see “Working Steps for 1piece Parkrimp No-Skive Fittings”



Find the correct crimp specification on the push of a button!

www.parker.com/crimpsource-euro

Working steps

3

INSTALLATION



The **routing** of the hose assembly and the environment in which the hose assembly operates directly influence the service life of the hose assembly. The following diagrams indicate the correct routing of hose assemblies that will maximise its service life and assure a safe working functionality.

When hose installation is straight, it must be assured that there is enough slack in the hose to allow for changes in length that occur when pressure is applied. When pressurized, hose that is too short may pull loose from its hose fittings or stress the hose fitting connections, causing premature metallic or seal failures.

The **hose length** must be determined so that the hose assembly has enough slack to allow the system components to move or vibrate without creating tension in the hose.

However, care needs to be taken not to allow too much slack and therefore introduce the risk of the hose snagging on other equipment or rubbing on other components.

Mechanical straining of the hoses needs to be avoided, so the hose must not be bent below its minimum bend radius or twisted during installation. The minimum bending radii for each hose is stated in the hose tables in the catalogue.

The plane of movement must also be considered and the hose routing selected accordingly.

Hose routing also plays an important role on the selection of the hose fittings, as the correct fittings can avoid straining the hoses, unnecessary hose length or multiple threaded joints.



The hose assembly

Working steps

wrong

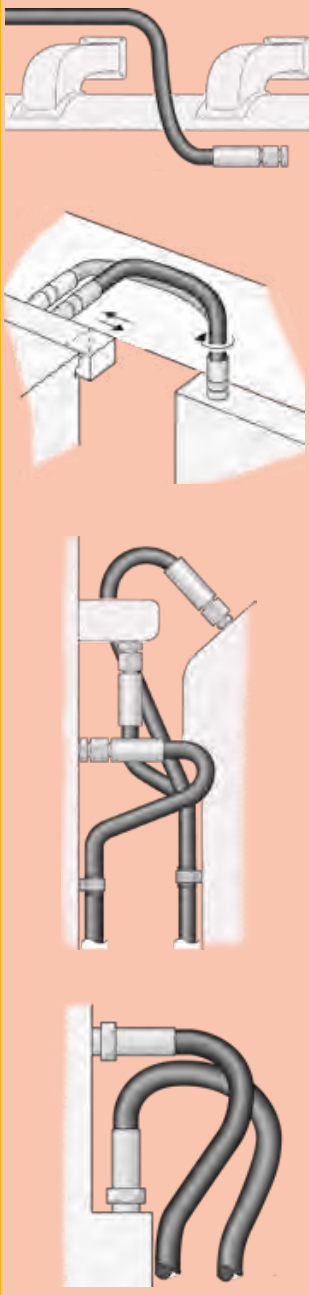

Correct clamping (holding/supporting) of the hose should be exercised to securely route the hose or to avoid the hose contacting surfaces that will cause the hose damage.

It is however, vital that the hose be allowed to keep its functionality as a “flexible-pipe” and not be restricted from changing in length when under pressure.

It should also be noted that hoses for high- and low-pressure lines shall not be crossed or clamped together, as the difference in changes in length could wear the hose covers. Hose should not be bent in more than one plane. If hose follows a compound bend, it shall be coupled into separate segments or clamped into segments that each flex in only one plane.

Hoses should be kept away from hot parts as high ambient temperatures shorten hose life. Protective insulation may need to be used in unusually high ambient temperature areas.

Whilst the importance of the functionality is preme the aesthetics and practicality of the installation should also be considered in the design.

It should be considered that maintenance might be necessary at some stage in the future, so prohibitive design routings should be avoided.

right

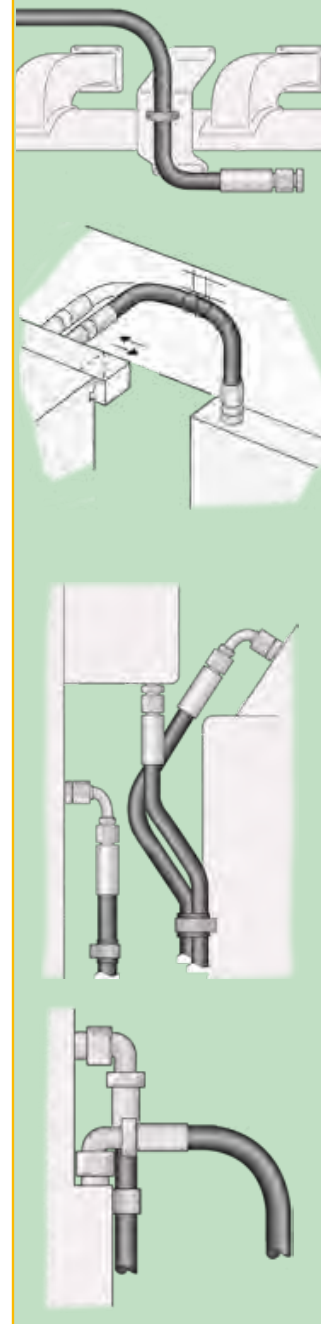

Working steps

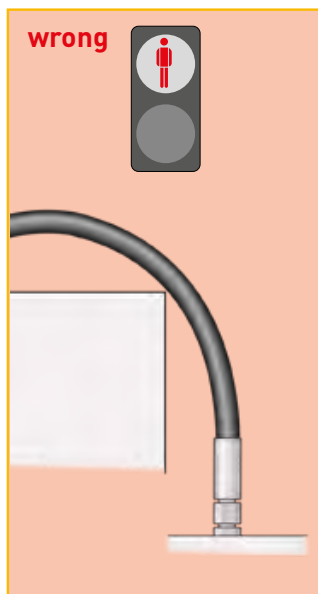

Abrasive influences

In general care should be taken that the hose is not exposed to direct surface contact that will cause abrasive wearing of the outer cover (either hose to object or hose to hose contact). If however, the application is such that this cannot be avoided, either a hose with a higher abrasion resistant hose cover or a protective sleeve need to be used.

Parker **TOUGH COVER** (TC) or **SUPER TOUGH** (ST) covers offer 80 times or respectively 450 times the abrasion resistance of standard rubber covers.



Pollution of hydraulic circuits

Modern hydraulic equipment is becoming highly precise and as such more sensitive, so as a result the importance of a clean working fluid in the system is growing. Because as many as 75 % of hydraulic system failures are caused by contamination of the fluid by solid particles, the initial cleanliness of hydraulic components, as the main source of these contaminants, is vital. With hose assemblies most of the pollution/contaminates enter the hose assembly during its production and mainly during the cutting (or skiving) process.

In order to avoid system failures, all hose assemblies should be cleaned before use (cleaned and plugged before shipping) with suitable cleaning equipment; please see also page **Ea-15** up to **Ea-18**.

The level of contamination is defined in three popular norms: ISO4406, ISO4405 or NAS 1638. Most common however, is the ISO 4406, which describes the number and size of solid particles in the hydraulic system by means of a classification value e.g. 16/13.



How to order

Hose and hose fittings

To make ordering Parker products easier, we have itemized the order numbers on this page. This will be especially helpful when you order hose assemblies.

Hose

Example:

462TC-6

462TC-6 → Hose type

462TC-6 → Hose inside diameter in size



Hose fittings

Example:

1CA48-12-6

1CA48-12-6 → Fitting

1CA48-12-6 → End configuration

1CA48-12-6 → Parker fitting series

1CA48-12-6 → Thread or tube size

1CA48-12-6 → Hose / fitting size

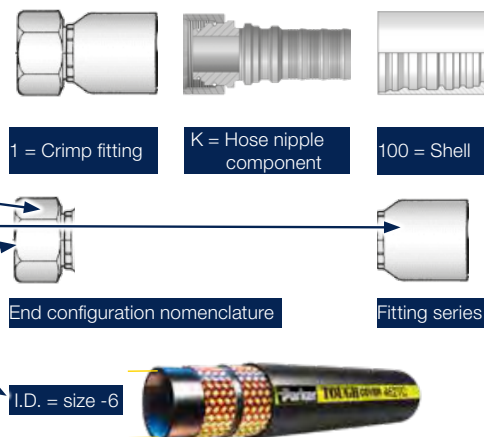

Material and specification:

Without suffix: steel, zinc plated, Cr6-free

B: brass

C: stainless steel

K: without a plastic ring

SM: metric hexagon dimension

The content of the hose crimping tables shows the standard part numbers.

For the availability of non standard parts and materials please contact your local Parker service centre.

Hose assemblies



Hose assemblies

Example:
P462TCCACF12106-1000-0-SG900

| | |
|----------------------------------------|-------------------------------------------------------------------------------------------------------------------------------------------------------------------------------------------------------------------------------------------------------------------------------------------------|
| P 462TCCACF12106-1000-0-SG900 | Hose type |
| P 462TC CACF12106-1000-0-SG900 | Fitting 1 end configuration |
| P462TC CA CF12106-1000-0-SG900 | Fitting 2 end configuration |
| P462TCC CA CF12106-1000-0-SG900 | Fitting 1 thread or tube size |
| P462TCCAC F 12106-1000-0-SG900 | Fitting 1 thread or tube size |
| P462TCCACF12 106 -1000-0-SG900 | Hose / fitting size |
| P462TCCACF1210 6 -1000-0-SG900 | Hose assembly length in mm |
| P462TCCACF12106- 1000 -0-SG900 | Displacement angle is relevant when the hose assembly has bent fittings |
| P462TCCACF12106-1000- 0 -SG900 | Accessory (e.g. spring guard 900 mm length) SG → Spring Guard AG → Armour Guard AS/PS → Partek Nylon protective sleeve FS → Fire Sleeves HG → PolyGuard-Hose Protector PG → Parkoil-Hose Protector DM → Minesleeve |
| P462TCCACF12106-1000-0- SG900 | |

Explanation of the example

Hose assembly with hose 462TC in size -6 and fitting series 48.

Hose assembly length 1000 mm.

Fitting 1: end configuration CA has a 12 mm pipe diameter and has a size -6 hose nipple

Fitting 2: end configuration CF has a 10 mm pipe diameter and has a size -6 hose nipple

The displacement angle for this combination is 0 degrees. On request a displacement angle can be specified for the bent fitting in relation with the hose curvature. A protection sleeve as a spring guard in length 900 mm is on the hose assembly.

Identifying fitting types

Determining sealing mechanisms

In general fittings can be identified by their visual appearance, their sealing surface/sealing type or by their thread type/form. Viewing the following pages, the visual identification will be self explanatory. The sealing mechanism and the method of thread identification, however, needs further explanation

Thread interface

The sealing is assured by the flattening of the edges of the threads when the male is screwed into the female fitting. Typically the front of the male fittings is narrower than the back of the fittings – often referred to as tapered threads.

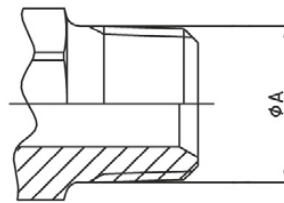

O-ring

The O-ring on the male is compressed against the corresponding female and assures the seal. This type of sealing mechanism should be the preferred choice for high-pressure applications. be convex or concave (seat) on the male or in the head of the pipe of the female as shown.

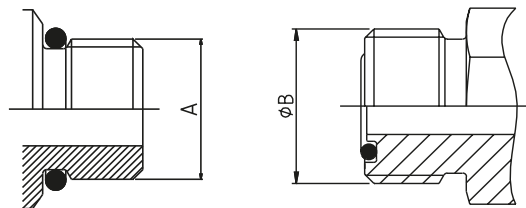

Matching angle or metal-to-metal joint

Sealing takes place where the two angled faces of the male and corresponding female meet and are wedged into one another by the tightening of the threaded nut. The sealing surfaces can either be convex or concave (seat) on the male or in the head of the pipe of the female as shown.

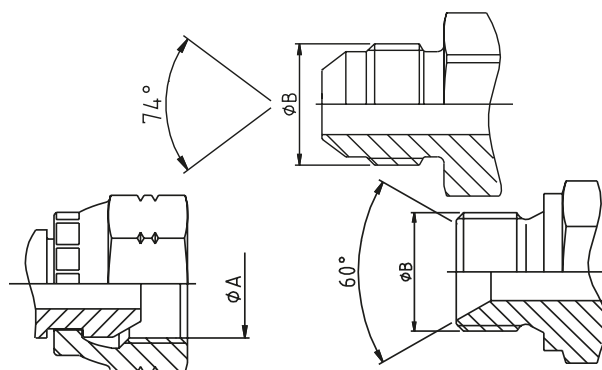

Matching angle with O-ring

These fittings combine the functionality of both the matching angle seal with the O-ring. The O-ring is in the angled sealing surface of the fitting so that when the threaded male and female are screwed together the sealing surfaces wedge together and at the same time deform the O-ring between them.

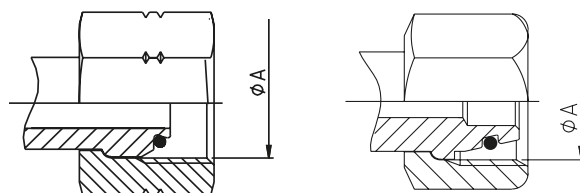

Determining the thread type

In general of the threads of various fittings look similar and hinder the easy identification of the thread. To assure the correct identification, the threads must be measured and compared to the tables listed in the following section.

Thread gauge

Using a thread gauge, the number of threads per inch can be determined.

Holding the gauge and coupling threads in front of a lighted background helps to obtain an accurate measurement.

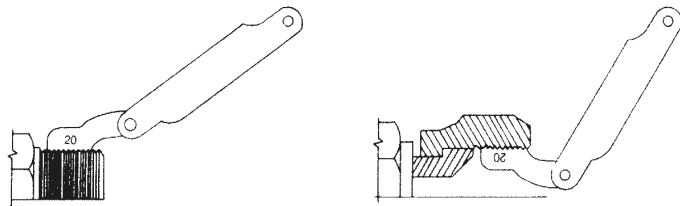

Caliper measure

A vernier caliper should be used to measure the thread diameter of the largest point. (Outside diameter (O.D.) of male threads – Inside Diameter (I.D.) of female threads.)

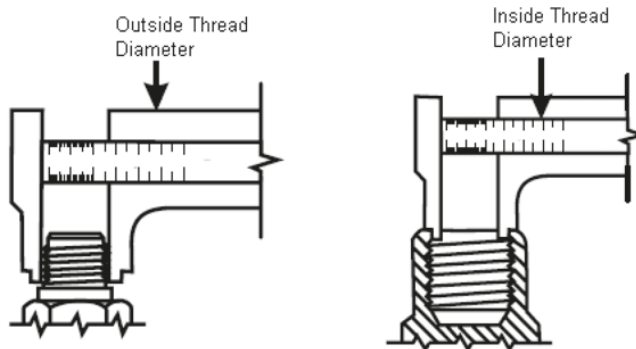

European thread types

DIN (DIN – Deutsches Institut für Normung)

Often referred to as metric fittings, these fittings seal using the angled sealing surfaces (metal-to-metal) or the combination of metal-to-metal with O-rings. They are available in **very light (LL)**, **light (L)** or **heavy series (S)**. The sealing face angles are either 24° with or without O-rings, or 24°/60° universal cones. Identification is made by measuring the thread size and also the tube outside diameter.

Thread

Defined by the outside diameter and the pitch (distance between 2 crests of the thread) example: M22x1.5 - pitch of 1.5mm.

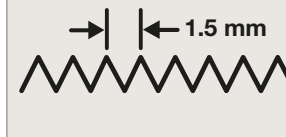

DIN 24° light (L) and heavy series (S) with O-ring

The male has a 24° sealing angle cone seat with straight metric threads.

The female has a 24° convex cone with O-ring and a swivel straight metric threaded nut.

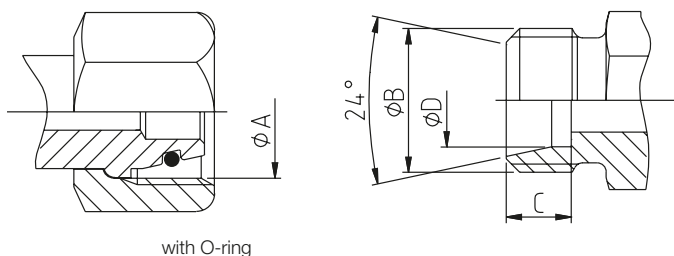

with O-ring

Standard: **ISO 12151-2**,
ISO 8434-1, **ISO 8434-4**

(Previously
DIN 20 078 Part 4, 5, 8, 9)

Light series Parker end configurations: **CA, CE, CF, D0**

Heavy series Parker end configurations: **C9, 0C, 1C, D2**

| Tube O.D. (mm) | Spec. | Thread metric | ϕA (mm) | ϕB (mm) | C (mm) | ϕD (mm) |
|----------------|-------|---------------|---------------|---------------|--------|---------------|
| 6.00 | 6L | M12X1.5 | 10.50 | 12.00 | 7.00 | 6.20 |
| 6.00 | 6S | M14X1.5 | 12.50 | 14.00 | 7.00 | 6.20 |
| 8.00 | 8L | M14x1.5 | 12.50 | 14.00 | 7.00 | 8.20 |
| 8.00 | 8S | M16x1.5 | 14.50 | 16.00 | 7.00 | 8.20 |
| 10.00 | 10L | M16x1.5 | 14.50 | 16.00 | 7.00 | 10.20 |
| 10.00 | 10S | M18x1.5 | 16.50 | 18.00 | 7.50 | 10.20 |
| 12.00 | 12L | M18x1.5 | 16.50 | 18.00 | 7.00 | 12.20 |
| 12.00 | 12S | M20x1.5 | 18.50 | 20.00 | 7.50 | 12.20 |
| 14.00 | 14S | M22x1.5 | 20.50 | 22.00 | 8.00 | 14.20 |
| 15.00 | 15L | M22x1.5 | 20.50 | 22.00 | 7.00 | 15.20 |
| 16.00 | 16S | M24x1.5 | 22.50 | 24.00 | 8.50 | 16.20 |
| 18.00 | 18L | M26x1.5 | 24.50 | 26.00 | 7.50 | 18.20 |
| 20.00 | 20S | M30x2 | 27.90 | 30.00 | 10.50 | 20.20 |
| 22.00 | 22L | M30x2 | 27.90 | 30.00 | 7.50 | 22.20 |
| 25.00 | 25S | M36x2 | 33.90 | 36.00 | 12.00 | 25.20 |
| 28.00 | 28L | M36x2 | 33.90 | 36.00 | 7.50 | 28.20 |
| 30.00 | 30S | M42x2 | 39.90 | 42.00 | 13.50 | 30.20 |
| 35.00 | 35L | M45x2 | 42.90 | 45.00 | 10.50 | 35.30 |
| 38.00 | 38S | M52x2 | 49.90 | 52.00 | 16.00 | 38.30 |
| 42.00 | 42L | M52x2 | 49.90 | 52.00 | 11.00 | 42.30 |

BSP (British Standard Pipe)

Also referred to as Whitworth threads, the BSP thread type fittings seal use metal-to-metal angled surfaces or a combination of metal-to-metal and an O-ring. The angle of the sealing surfaces is 60° for both forms.

There are two popular thread forms: British Standard Pipe Parallel (BSPP) and British Standard Pipe Tapered (BSPT).

Thread

Identification is made by measuring the outside diameter of the thread and the number of threads per inch (25.4 mm)

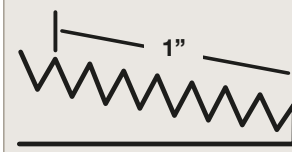

BSPP

metal-to-metal without O-ring

Standard: **BS5200, ISO 8434-6**

Parker end configurations:

92, B1, B2, B4, D9

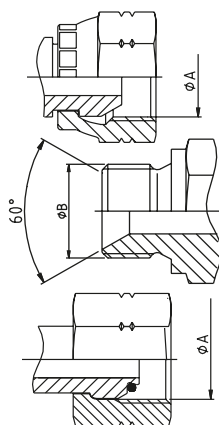

| Tube I.D./O.D. (mm) | Size | Thread BSP | ØA (mm) | ØB (mm) |
|---------------------|------|------------|---------|---------|
| 6/10 | -2 | 1/8x28 | 8.60 | 9.70 |
| 8/13 | -4 | 1/4x19 | 11.50 | 13.20 |
| 12/17 | -6 | 3/8x19 | 14.90 | 16.70 |
| 15/21 | -8 | 1/2x14 | 18.60 | 20.90 |
| 18/23 | -10 | 5/8x14 | 20.60 | 22.90 |
| 20/27 | -12 | 3/4x14 | 24.10 | 26.40 |
| 26/34 | -16 | 1x11 | 30.30 | 33.20 |
| 33/42 | -20 | 1-1/4x11 | 38.90 | 41.90 |
| 40/49 | -24 | 1-1/2x11 | 44.90 | 47.80 |
| 50/60 | -32 | 2x11 | 56.70 | 59.60 |

BSPP

metal-to-metal with O-ring

Standard: **ISO 12151-6,**

ISO 8434-6

Parker end configurations:

EA, EB, EC, EE, D9

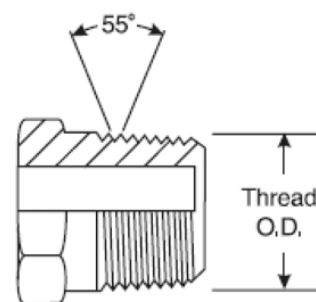

| Tube I.D./O.D. (mm) | Size | Thread BSP | ØA (mm) |
|---------------------|------|------------|---------|
| 5/10 | -2 | 1/8x28 | 9.73 |
| 8/13 | -4 | 1/4x19 | 13.16 |
| 12/17 | -6 | 3/8x19 | 16.66 |
| 15/21 | -8 | 1/2x14 | 20.96 |
| 20/27 | -12 | 3/4x14 | 26.44 |
| 26/34 | -16 | 1x11 | 33.25 |
| 33/42 | -20 | 1-1/4x11 | 41.91 |
| 40/49 | -24 | 1-1/2x11 | 47.80 |
| 50/60 | -32 | 2x11 | 59.61 |

BSPT

fittings seal through the thread interface mechanism. Care should be taken not to confuse the BSPT fitting with the NPTF male fitting. BSPT has a 55° thread angle. NPTF has 60° thread angle.

Parker end configurations: **91**

BSP flat seal

These fittings have BSP parallel threads but the sealing surface is flat. The seal is made when the composite seal is compressed against the female flat face.

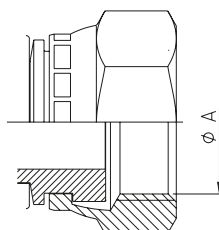

| Tube I.D./O.D. (mm) | Size | Thread BSP | ØA (mm) |
|---------------------|------|------------|---------|
| 6/10 | -2 | 1/8x28 | 8.6 |
| 8/13 | -4 | 1/4x19 | 11.5 |
| 12/17 | -6 | 3/8x19 | 14.9 |
| 15/21 | -8 | 1/2x14 | 18.6 |
| 18/23 | -10 | 5/8x14 | 20.6 |
| 20/27 | -12 | 3/4x14 | 24.1 |
| 26/34 | -16 | 1x11 | 30.3 |

Parker end configurations:

B5, B6, B7

North American thread types

NPTF / SAE JIC 37°

This type of fitting uses the thread interface to seal and as such has a tapered thread that deforms and forms the seal. They have 30° sealing angle surfaces, forming a 60° inverted (concave) seat. The fittings are most frequently seen on machines of US origin.

Dryseal american standard taper pipe thread (NPTF)

The NPTF male will mate with the NPTF, NPSF, or NPSM females. Care should be taken not to confuse the NPTF fitting with the BSPT male fitting. NPTF fittings have a 60° thread angle. BSPT has a 55° thread angle.

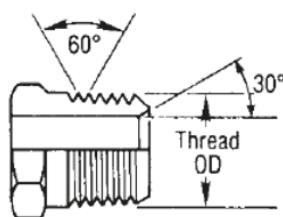

ØA dimension is measured on the 4th pitch of the thread

| Size | Thread NPTF | ØA (mm) | ØB (mm) |
|------|-------------|---------|---------|
| -2 | 1/8x27 | 10.24 | 8.73 |
| -4 | 1/4x18 | 13.61 | 11.90 |
| -6 | 3/8x18 | 17.05 | 15.90 |
| -8 | 1/2x14 | 21.22 | 19.05 |
| -12 | 3/4x14 | 26.56 | 24.60 |
| -16 | 1x11.5 | 33.22 | 30.95 |
| -20 | 1-1/4x11.5 | 41.98 | 39.69 |
| -24 | 1-1/2x11.5 | 48.05 | 45.24 |
| -32 | 2x11.5 | 60.09 | 57.15 |

Standard: **SAE J516**

Parker end configurations: **01**

SAE JIC 37°

Commonly referred to as JIC fittings, these metal-to-metal sealing type fittings have a 37° flare (sealing surface angle) and straight United National Fine Threads (UNF).

The original design specification for the fittings comes from the Society of Automotive Engineers (SAE) and these fittings are the most common American fitting types in Europe. Parker JIC hose fittings are fully compatible with Parker Triple-Lok Tube Fittings and adapters.

Standard: **ISO 12151-5, ISO8434-2, SAE J516**

Parker end configurations: **03, 06/68, 37/3V, 39/3W, 41/3Y, L9**

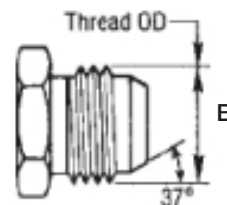
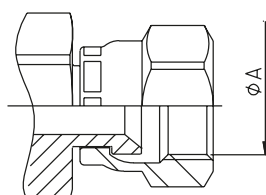

| Tube O.D. (inch) | Tube O.D. (mm) | Thread UNF | Size | ØA (mm) | ØB (mm) |
|------------------|----------------|------------|------|---------|---------|
| 3/16 | | 3/8x24 | -3 | 8.60 | 9.50 |
| 1/4 | 6 | 7/16x20 | -4 | 10.00 | 11.10 |
| 5/16 | 8 | 1/2x20 | -5 | 11.60 | 12.70 |
| 3/8 | 10 | 9/16x18 | -6 | 13.00 | 14.30 |
| 1/2 | 12 | 3/4x16 | -8 | 17.60 | 19.10 |
| 5/8 | 14-15-16 | 7/8x14 | -10 | 20.50 | 22.20 |
| 3/4 | 18-20 | 1-1/16x12 | -12 | 24.60 | 27.00 |
| 7/8 | 22 | 1-3/16x12 | -14 | 28.30 | 30.10 |
| 1 | 25 | 1-5/16x12 | -16 | 31.30 | 33.30 |
| 1-1/4 | 30-32 | 1-5/8x12 | -20 | 39.20 | 41.30 |
| 1-1/2 | 38 | 1-7/8x12 | -24 | 45.60 | 47.60 |
| 2 | | 2-1/2x12 | x32 | 61.50 | 63.50 |

ORFS

O-ring face seal (ORFS)

ORFS fittings are becoming the most popular international fitting type used on global OEM machines due to their high level of sealing and their good vibration resistance. The fittings use the O-ring compression mechanism to seal.

The female fittings have flat faces and straight threaded UNF swivel nuts. The male fittings have the O-ring in a groove in the flat face. Seen as a major advantage, these fittings offer the possibility to build the hose assemblies into fixed distances/spaces, without having to move back other system components due the flat faces of the male and female fittings – the hose assembly can be slotted in.

Standard: **ISO 12151-1, ISO8434-3, SAE J516**

Parker end configurations: **JC, JM/J0, JS, JU, J1, J3, J5, J7, J9**

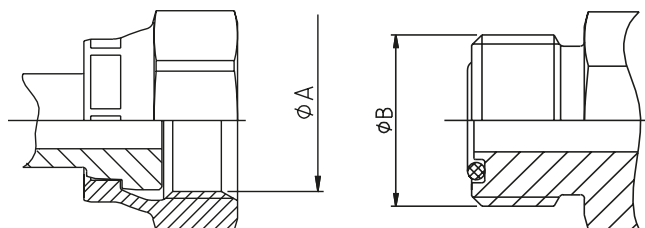

| Tube O.D. (inch) | Tube O.D. (mm) | Thread UNF | Size | ϕA (mm) | ϕB (mm) |
|------------------|----------------|------------|------|---------------|---------------|
| 1/4 | 6 | 9/16x18 | -4 | 13.00 | 14.20 |
| 3/8 | 10 | 11/16x16 | -6 | 15.90 | 17.50 |
| 1/2 | 12 | 13/16x16 | -8 | 19.10 | 20.60 |
| 5/8 | 16 | 1x14 | -10 | 23.80 | 25.40 |
| 3/4 | 20 | 1-3/16x12 | -12 | 28.20 | 30.10 |
| 1 | 25 | 1-7/16x12 | -16 | 34.15 | 36.50 |
| 1-1/4 | 32 | 1-11/16x12 | -20 | 40.50 | 42.90 |
| 1-1/2 | 38 | 2x12 | -24 | 48.80 | 50.80 |

North American thread types

Flanges ISO 6162-1 and ISO 6162-2

Flange fittings

ISO 6162-1 and ISO 6162-2

The 4-bolt split flange (or full flange) fitting is used worldwide for connecting high-pressure hoses typically to pumps, motors and cylinders, where the hose assemblies are subjected to large pressure loadings.

The sealing mechanism is through compression of the O-ring in the face of the flange head against the surface of the port/connection.

The flange fittings are generally separated into two pressure classes referred to as 21.0 MPa/ 3000 psi (SFL) or 42.0 MPa/ 6000 psi (SFS). ISO 12151-3 refers to the flange fittings to as 21.0 MPa/ 3000 psi (SFL) or 42.0 MPa/ 6000 psi (SFS). In addition to these flanges, customer-specific Komatsu® and CATERPILLAR® flanges can also be found in the market.

ISO 6162-1 (21.0 MPa/ 3000 psi)
Parker end configurations:
15, 16, 17, 19, P5, P7, P9

ISO 6162-1 (35.0 MPa/ 5000 psi)
Parker end configurations:
4A, 4F, 4N

ISO 6162-2 (42.0 MPa/ 6000 psi)
Parker end configurations:
6A, 6F, 6N, PA, PF, PN, 89

Caterpillar flange Parker end configurations: **XA, XF, XG, XN**

- Standard ISO 6162-1 for 21.0 MPa/ 3000 psi to 35.0 MPa/ 5000 psi max., depending on size
- High Pressure ISO 6162-2 for 42.0 MPa/ 6000 psi max. regardless of size

| Flange (inch) | Size | ISO 6262-1 MPa / psi | ISO 6162-2 MPa / psi |
|---------------|------|----------------------|----------------------|
| 1/2 | -8 | 34.5 / 5000 | 41.3 / 6000 |
| 3/4 | -12 | 34.5 / 5000 | 41.3 / 6000 |
| 1 | -16 | 34.5 / 5000 | 41.3 / 6000 |
| 1-1/4 | -20 | 27.5 / 4000 | 41.3 / 6000 |
| 1-1/2 | -24 | 20.7 / 3000 | 41.3 / 6000 |
| 2 | -32 | 20.7 / 3000 | 41.3 / 6000 |

Note: 35.0 MPa/ 5000 psi in size -20/-24/-32 with 4A,4F and 4N fittings and 50H flange halves.

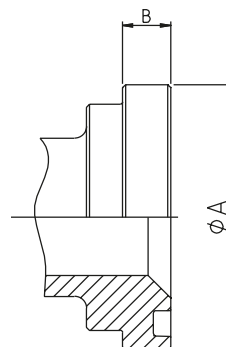

ISO 6162-1 – 21.0 MPa/ 3000 psi

| Flange (inch) | Size | ØA (mm) | B (mm) | O-Ring |
|---------------|------|---------|--------|------------|
| 1/2 | -8 | 30.18 | 6.73 | 18.64x3.53 |
| 3/4 | -12 | 38.10 | 6.73 | 24.99x3.53 |
| 1 | -16 | 44.45 | 8.00 | 32.92x3.53 |
| 1-1/4 | -20 | 50.80 | 8.00 | 37.69x3.53 |
| 1-1/2 | -24 | 60.33 | 8.00 | 47.22x3.53 |
| 2 | -32 | 71.42 | 9.53 | 56.74x3.53 |
| 2-1/2 | -40 | 84.12 | 9.53 | 69.44x3.53 |
| 3 | -48 | 101.60 | 9.53 | 85.32x3.53 |

ISO 6162-2 – 42.0 MPa/ 6000 psi

| Flange (inch) | Size | ØA (mm) | B (mm) | O-Ring |
|---------------|------|---------|--------|------------|
| 1/2 | -8 | 31.75 | 7.75 | 18.64x3.53 |
| 3/4 | -12 | 41.28 | 8.76 | 24.99x3.53 |
| 1 | -16 | 47.63 | 9.53 | 32.92x3.53 |
| 1-1/4 | -20 | 53.98 | 10.29 | 37.69x3.53 |
| 1-1/2 | -24 | 63.50 | 12.57 | 47.22x3.53 |
| 2 | -32 | 79.38 | 12.57 | 56.74x3.53 |

CATERPILLAR®

| Flange (inch) | Size | ØA (mm) | B (mm) | O-Ring |
|---------------|------|---------|--------|------------|
| 3/4 | -12 | 41.28 | 14.22 | 25.40x5.00 |
| 1 | -16 | 47.63 | 14.22 | 31.90x5.00 |
| 1-1/4 | -20 | 53.98 | 14.22 | 38.20x5.00 |
| 1-1/2 | -24 | 63.50 | 14.22 | 44.70x5.00 |

Komatsu®

| Flange (inch) | Size | ØA (mm) | B (mm) | O-Ring |
|---------------|------|---------|--------|----------|
| 5/8 | -10 | 34.25 | 6.00 | 21.7x3.5 |

Although not in the SAE or the ISO standard the size -10 (5/8) flange head is gaining popularity. This flange is often found on Komatsu equipment or hydrostatic drives in agricultural machines.

4-bolt split flange

4-bolt split flange

A 4-bolt split flange is used to attach the flange fittings to their ports.

- Standard ISO 6162-1 for 21.0 MPa (3000 psi) to 35.0 MPa (5000 psi) max., depending on size
- High Pressure ISO 6162-2 for 42.0 MPa (6000 psi) max., regardless of size

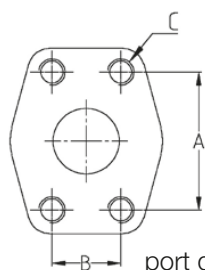

port dimensions

ISO 6162-1 – 21.0 MPa (3000 psi)

| Flange (inch) | Size | A (mm) | B (mm) | C | |
|---------------|------|--------|--------|---------|-----------|
| | | | | (inch) | (metr.) |
| 1/2 | -8 | 38.1 | 17.5 | 5/16x18 | M8x1.25 |
| 3/4 | -12 | 47.6 | 22.3 | 3/8x16 | M10x1.5 |
| 1 | -16 | 52.4 | 26.2 | 3/8x16 | M10x1.5 |
| 1-1/4 | -20 | 58.7 | 30.2 | 7/16x14 | M10x1.5 |
| 1-1/2 | -24 | 69.9 | 35.7 | 1/2x13 | M12x1.75 |
| 2 | -32 | 77.8 | 42.8 | 1/2x13 | M12x1.75* |

ISO 6162-2 – 42.0 MPa (6000 psi)

| Flange (inch) | Size | A (mm) | B (mm) | C | |
|---------------|------|--------|--------|---------|-----------|
| | | | | (inch) | (metr.) |
| 1/2 | -8 | 40.5 | 18.2 | 5/16x18 | M8x1.25 |
| 3/4 | -12 | 50.8 | 23.8 | 3/8x16 | M10x1.5 |
| 1 | -16 | 57.2 | 27.8 | 7/16x14 | M12x1.75 |
| 1-1/4 | -20 | 66.7 | 31.8 | 1/2x13 | M12x1.75* |
| 1-1/2 | -24 | 79.4 | 36.5 | 5/8x11 | M16x2 |
| 2 | -32 | 96.8 | 44.4 | 3/4x10 | M20x2.5 |

*M14x2 still used in the market but no longer in accordance with ISO 6162

Storage

Hoses and hose fittings

It is a well-known fact that rubber properties deteriorate during the time of storage and service. A system of hose age control should be maintained to ensure that hose is used as long as it retains full capabilities for rendering the intended service.

However, it is impossible to advise the ideal storage period and service life of rubber hose as it is subject to a variety of factors which may affect the rubber characteristics and the suitability for use.

That is also why various standardization committees take very different approaches to rubber hose storage period and service life. The main national and international standards defining rules for rubber hose storage are the following:

DIN 20066

Fluid power systems – hose assemblies – dimensions, requirements

Specifies bulk hose shelf life and hose assembly storage period and service life:

- The shelf life of bulk hose before assembling must not exceed 4 years.
- The service life of a hose assembly, incl. any period of storage, should not exceed 6 years.
- The period of storage of a hose assembly must not exceed 2 years.

Bulk Hose

Shelf life
– max. 4 years

Hose Assembly

Service life – max. 6 years

Storage
max. 2 years

BS 5244

Recommendations for application, storage and life expiry of hydraulic rubber hoses and hose assemblies

Specifies tests needed for various storage periods of hose (in bulk or hose assembly):

- Storage period does not exceed 3 years
– no tests needed.
- Storage period is between 3 and 5 years
– proof pressure test needed.
- Storage period is between 5 and 8 years
– proof pressure, burst, impulse, cold flexibility and electrical tests needed.
- Bulk hose or a hose assembly older than 8 years
– must be scrapped.

For hose assembly service life no explicit limits are specified, whereas it is recommended to establish rules for each particular equipment and application on the basis of records taken from the real service.

Hint

German and the British standards are the most rigorous.

ISO 17165-2 / SAE J1273

Hydraulic fluid power – hose assemblies – recommended practices for hydraulic hose assemblies

The specified max. shelf life of bulk hose or a hose assembly is 10 years (40 quarters) from the date of manufacture (vulcanization) of the hose, provided it has been stored in accordance with ISO 2230 (Rubber products - Guidelines for storage) and passes visual inspection and if need be also a proof pressure test. If visual inspection gives rise to any doubts as to the functionality of the hose (cracks in the cover or tube after hose flexing, excessive stiffness, reinforcement rust etc.), a proof pressure test should be carried out before use or the hose should be scrapped.

ISO 8331

Rubber and plastic hoses and hose assemblies – guide to selection, storage, use and maintenance

Specifies storage periods similar to DIN 20066 – bulk hose max. 4 years, a hose assembly max. 2 years. If the storage exceeds these limits the hose must be inspected and tested (tests are not specified). Hose assembly service life is not specified.

OEM regulations

In addition to these national and international standards, also some Original Equipment Manufacturers (OEMs) have their own regulations for age of hose used for production of hose assemblies.

We recommend generally observe the regulations relevant for your country or ISO 17165-2 (if there is no domestic regulation), plus the regulation of your customer's country or of your OEM customer in the extent in which they are more demanding.

Best practices

Hoses storage – best practices

Store hoses and hose assemblies in a cool, dark and dry room with capped ends in closed boxes (preferably in the original Parker packaging) and in the manner facilitating inspection of the hose condition and the first-in first-out (FIFO) inventory control system.

The main factors determining the hose storage are:

a) Temperature

Preferably between 15 °C and 25 °C, without rapid and frequent fluctuation.

b) Humidity

Preferably not higher than 65 %, protect hose against moisture and avoid atmospheric humidity condensation.

c) Heat

Store hose away from heat sources.

d) Light

Protect hose against direct sun light, light of discharge lamps and other ultraviolet sources.

e) Corrosive liquids and fumes

Do not store in the same room with corrosive chemicals.

f) Ozone

Avoid using high power electrical equipment and electrical spark sources in the storage room.

g) Oils and greases

Avoid direct contact.

h) Space and bends

Keep hose in stress-free shape never bent below the min. bend radius.

i) Electrical and magnetic fields

Store hose away from powerful electric transformers, motors and generators that could induce current in the hose metal reinforcement.

j) Rodents and insects

Protect against rodents and insects.

Fittings storage – best practices

For storing fittings the same rules as for hose are applicable (especially for fittings with rubber sealing), in addition:

a) Mismatching and confusing

Avoid unnecessary repacking and store fittings in clearly marked closed containers (preferably in the original Parker packaging).

b) Damage of threads and sealing surfaces

Avoid unnecessary reloading and handling.

c) Fittings with O-rings

Assure that storage period of fittings with O-rings or other rubber sealing does not exceed 2 years (remember: first in-first out) and make sure that hose assemblies or hose fittings with O-rings will be stored in a cool, dry and dark room.

d) Caps

Hose assemblies fittings should be capped against damage and contamination.



Safety first!

A hydraulic hose assembly is a power component and may cause property damage, personal injury or death!

WARNING: Injuries in which hydraulic or other liquid is involved must be treated without delay and not the same way as an ordinary injury!

1. High pressure fluid injection can be almost invisible, leaking from a pinhole, but it can pierce the skin deep into the muscle!
2. If a fluid-injection accident occurs, search immediately for a medical treatment by a doctor!
3. Don't touch pressurized hydraulic hose assemblies and don't look at them from a short distance – especially not close to fittings!
4. Secure ends of hydraulic assemblies with high pulsing pressure and all high pressure air hose assemblies against blow-off of the hose from the fitting with appropriate whip restraints!
5. Stay out of hazardous areas while testing hose assemblies under pressure and wear proper protective clothing and goggles!

We in Parker are making all efforts to develop, manufacture and deliver defect-free, durable and safe products and services – starting from integrated design and testing of all components through sharing our know-how with our customers and providing them with comprehensive support and training.

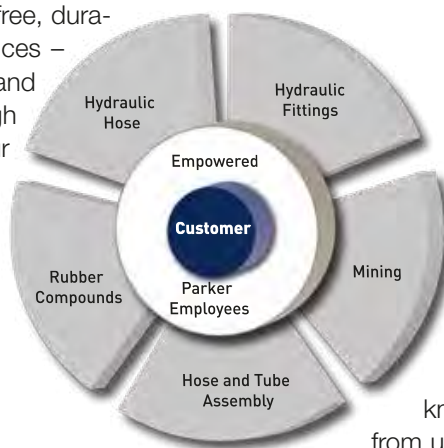

Please also make all efforts on your side to provide reliable and safe hose assemblies to your customers and forward to them the know-how you acquired, whether from us or due to your own unique experience, especially as regards the proper use and maintenance of hose assemblies.

Avoid injury to yourself and others by following these important rules



Aa-32

Carefully read and observe especially the following sections of this catalogue

- For selection of proper hose and fittings:
 - Safe Hose Assembly Working Steps (pages **Aa-9** ff)
 - Technical Data (pages **Aa-2** ff)
- For manufacturing of hose assemblies:
 - Working Steps for 1piece **Parkrimp** Fittings (pages **Aa-12** ff)
 - Working Steps for 2piece **ParLock** Fittings (pages **Aa-15** ff)
 - Crimp Source (page **Ed-1**)
- For storing, packing and handling:
 - Hose and Fittings Storage (pages **Aa-34** ff)
- For installation on machines:
 - Routing / Installation / Environmental Influences (pages **Aa-17** ff)
- Inspection, maintenance and replacement:
 - Preventive Maintenance Program (page **Aa-26**)
- **READ CAREFULLY AND OBSERVE:**
 - **Parker Safety Guide** for Selecting and Using Hose, Tubing, Fittings and Related Accessories (pages **Aa-38** ff)
- **INVESTIGATE, STUDY AND OBSERVE all relevant international and national standards and directives** of your local trade, technical and work safety associations, such as:
 - **ISO 17165-1** *Hydraulic Fluid Power – Hose Assemblies*
 - **ISO 17165-2** *Hydraulic Fluid Power – Hose Assemblies*
 - **ISO 4413** *Hydraulic fluid power – General rules and safety requirements for systems and their components*
 - **SAE J1273** *Recommended Practices for Hydraulic Hose Assemblies*
- In Germany**
 - **DGUV Regel 113-020** *Hydraulik-Schlauchleitungen und Hydraulik-Flüssigkeiten – Regeln für den sicheren Einsatz*
 - **FA 015** *Hydraulik-Schlauchleitungen Prüfen und Auswechseln*
 - **DGUV Information 209-070** *Sicherheit bei der Hydraulik-Instandhaltung*
- In UK**
 - **BFPDA D8** *Quality Control Procedures and Requirements for BFPDA Distributors*
 - **BFPDA D14** *A Simple Rule for Re-ending Hydraulic Hose Assemblies – Don't*
 - **BFPDA P47** *Guidelines for the Use of Hydraulic Fluid Power Hose and Hose Assemblies*

Hose Hint

There are several analogies between hydraulic and electric systems and it is not inappropriate to compare high-pressure hydraulic hoses to high-voltage electrical cables and to advise to regard and handle them with similar caution and care!

Parker safety guide

Parker safety guide for selecting and using hose, tubing, fittings and related accessories

Parker Publication No. 4400-B.1 / Revised: September, 2015



WARNING

Failure or improper selection or improper use of hose, tubing, fittings, assemblies, valves, connectors, conductors or related accessories ("Products") can cause death, personal injury and property damage. Possible consequences of failure or improper selection or improper use of these Products include but are not limited to:

- Fittings thrown off at high speed.
- High velocity fluid discharge.
- Explosion or burning of the conveyed fluid.
- Electrocutation from high voltage electric powerlines.
- Contact with suddenly moving or falling objects that are controlled by the conveyed fluid.
- Injections by high-pressure fluid discharge.
- Dangerously whipping Hose.
- Tube or pipe burst.
- Weld joint fracture.
- Contact with conveyed fluids that may be hot, cold, toxic or otherwise injurious.
- Sparking or explosion caused by static electricity buildup or other sources of electricity.
- Sparking or explosion while spraying paint or flammable liquids.
- Injuries resulting from inhalation, ingestion or exposure to fluids.

Before selecting or using any of these Products, it is important that you read and follow the instructions below. No product from any division in Fluid Connector Group is approved for in-flight aerospace applications. For hoses and fittings used in in-flight aerospace applications, please contact Parker Aerospace Group

1.0 GENERAL INSTRUCTIONS

Scope: This safety guide provides instructions for selecting and using (including assembling, installing, and maintaining) these Products. For convenience, all rubber and/or thermoplastic products commonly called "hose" or "tubing" are called "Hose" in this safety guide. Metallic tube or pipe are called "tube". All assemblies made with Hose are called "Hose Assemblies". All assemblies made with Tube are called "Tube Assemblies". All products commonly called "fittings", "couplings" or "adapters" are called "Fittings". Valves are fluid system components that control the passage of fluid. Related accessories are ancillary devices that enhance or monitor performance including crimping, flaring, flanging, presetting, bending, cutting, deburring, swaging machines, sensors, tags, lockout handles, spring guards and associated tooling. This safety guide is a supplement to and is to be used with the specific Parker publications for the specific Hose, Fittings and Related Accessories that are being considered for use. Parker publications are available at www.parker.com. SAE J1273 (www.sae.org) and ISO 17165-2 (www.ansi.org) also provide recommended practices for hydraulic Hose Assemblies, and should be followed.

1.1 Fail-Safe: Hose, Hose Assemblies, Tube, Tube Assemblies and Fittings can and do fail without warning for many reasons. Design all systems and equipment in a fail-safe mode, so that failure of the Hose, Hose Assembly, Tube, Tube Assembly or Fitting will not endanger persons or property.

1.2 Distribution: Provide a copy of this safety guide to each person responsible for selecting or using Hose, Tube and Fitting products. Do not select or use Parker Hose, Tube or Fittings without thoroughly reading and understanding this safety guide as well as the specific Parker publications for the Products.

1.3 User Responsibility: Due to the wide variety of operating conditions and applications for Hose, Tube and Fittings. Parker does not represent or warrant that any particular Hose, Tube or Fitting is suitable for any specific end use system. This safety guide does not analyze all technical parameters that must be considered in selecting a product. The user, through its own analysis and testing, is solely responsible for:

- Making the final selection of the Products.
- Assuring that the user's requirements are met and that the application presents no health or safety hazards.
- Following the safety guide for Related Accessories and being trained to operate Related Accessories.
- Providing all appropriate health and safety warnings on the equipment on which the Products are used.
- Assuring compliance with all applicable government and industry standards.

1.4 Additional Questions: Call the appropriate Parker technical service department if you have any questions or require any additional information. See the Parker publication for the Products being considered or used, or call 1-800-CPARKER, or go to www.parker.com, for

telephone numbers of the appropriate technical service department.

2.0 HOSE, TUBE AND FITTINGS SELECTION INSTRUCTIONS

2.1 Electrical Conductivity: Certain applications require that the Hose be nonconductive to prevent electrical current flow. Other applications require the Hose and the Fittings and the Hose/Fitting interface to be sufficiently conductive to drain off static electricity. Extreme care must be exercised when selecting Hose, Tube and Fittings for these or any other applications in which electrical conductivity or nonconductivity is a factor. The electrical conductivity or nonconductivity of Hose, Tube and Fittings is dependent upon many factors and may be susceptible to change. These factors include but are not limited to the various materials used to make the Hose and the Fittings, Fitting finish (some Fitting finishes are electrically conductive while others are nonconductive), manufacturing methods (including moisture control), how the Fittings contact the Hose, age and amount of deterioration or damage or other changes, moisture content of the Hose at any particular time, and other factors. The following are considerations for electrically nonconductive and conductive Hose. For other applications consult the individual catalog pages and the appropriate industry or regulatory standards for proper selection.

2.1.1 Electrically Nonconductive Hose: Certain applications require that the Hose be nonconductive to prevent electrical current flow or to maintain electrical isolation. For applications that require Hose to be electrically nonconductive, including but not limited to applications near high voltage electric lines, only special nonconductive Hose can be used. The manufacturer of the equipment in which the nonconductive Hose is to be used must be consulted to be certain that the Hose, Tube and Fittings that are selected are proper for the application. Do not use any Parker Hose or Fittings for any such application requiring nonconductive Hose, including but not limited to applications near high voltage electric lines or dense magnetic fields, unless (i) the application is expressly approved in the Parker technical publication for the product, (ii) the Hose is marked "nonconductive", and (iii) the manufacturer of the equipment on which the Hose is to be used specifically approves the particular Parker Hose, Tube and Fittings for such use.

2.1.2 Electrically Conductive Hose: Parker manufactures special Hose for certain applications that require electrically conductive Hose. Parker manufactures special Hose for conveying paint in airless paint spraying applications. This Hose is labeled "Electrically Conductive Airless Paint Spray Hose" on its layline and packaging. This Hose must be properly connected to the appropriate Parker Fittings and properly grounded in order to dissipate dangerous static charge buildup, which occurs in all airless paint spraying applications. Do not use any other Hose for airless paint spraying, even if electrically conductive. Use of any other Hose or failure to properly connect the Hose can cause a fire or an explosion resulting in death, personal injury, and property damage. All hoses that convey fuels must be grounded. Parker manufactures a special Hose for certain compressed natural gas ("CNG")

applications where static electricity buildup may occur. Parker CNG Hose assemblies comply with the requirements of ANSI/IAS NGV 4.2; CSA 12.52, "Hoses for Natural Gas Vehicles and Dispensing Systems" (www.ansi.org). This Hose is labeled "Electrically Conductive for CNG Use" on its layline and packaging. This Hose must be properly connected to the appropriate Parker Fittings and properly grounded in order to dissipate dangerous static charge buildup, which occurs in, for example, high velocity CNG dispensing or transfer. Do not use any other Hose for CNG applications where static charge buildup may occur, even if electrically conductive. Use of other Hoses in CNG applications or failure to properly connect or ground this Hose can cause a fire or an explosion resulting in death, personal injury, and property damage. Care must also be taken to protect against CNG permeation through the Hose wall. See section 2.6, Permeation, for more information. Parker CNG Hose is intended for dispenser and vehicle use within the specified temperature range. Parker CNG Hose should not be used in confined spaces or unventilated areas or areas exceeding the specified temperature range. Final assemblies must be tested for leaks. CNG Hose Assemblies should be tested on a monthly basis for conductivity per ANSI/IAS NGV 4.2; CSA 12.52. Parker manufactures special Hose for aerospace in-flight applications. Aerospace in-flight applications employing Hose to transmit fuel, lubricating fluids and hydraulic fluids require a special Hose with a conductive inner tube. This Hose for in-flight applications is available only from Parker's Stratoflex Products Division. Do not use any other Parker Hose for in-flight applications, even if electrically conductive. Use of other Hoses for in-flight applications or failure to properly connect or ground this Hose can cause a fire or an explosion resulting in death, personal injury and property damage. These Hose assemblies for in-flight applications must meet all applicable aerospace industry, aircraft engine and aircraft requirements.

2.2 Pressure: Hose, Tube and Fitting selection must be made so that the published maximum working pressure of the Hose, Tube and Fittings are equal to or greater than the maximum system pressure. The maximum working pressure of a Hose, or Tube Assembly is the lower of the respective published maximum working pressures of the Hose, Tube and the Fittings used. Surge pressures or peak transient pressures in the system must be below the published maximum working pressure for the Hose, Tube and Fitting. Surge pressures and peak pressures can usually only be determined by sensitive electrical instrumentation that measures and indicates pressures at millisecond intervals. Mechanical pressure gauges indicate only average pressures and cannot be used to determine surge pressures or peak transient pressures. Published burst pressure ratings for Hose is for manufacturing test purposes only and is no indication that the Product can be used in applications at the burst pressure or otherwise above the published maximum recommended working pressure.

2.3 Suction: Hoses used for suction applications must be selected to insure that the Hose will withstand the vacuum and pressure of the system. Improperly selected Hose may collapse in suction application.

2.4 Temperature: Be certain that fluid and ambient temperatures, both steady and transient, do not exceed the limitations of the Hose, Tube, Fitting and Seals. Temperatures below and above the recommended limit can degrade Hose, Tube, Fittings and Seals to a point where a failure may occur and release fluid. Tube and Fittings performances are normally degraded at elevated temperature. Material compatibility can also change at temperatures outside of the rated range. Properly insulate and protect the Hose Assembly when routing near hot objects (e.g. manifolds). Do not use any Hose in any application where failure of the Hose could result in the conveyed fluids (or vapors or mist from the conveyed fluids) contacting any open flame, molten metal, or other potential fire ignition source that could cause burning or explosion of the conveyed fluids or vapors.

2.5 Fluid Compatibility: Hose, and Tube Assembly selection must assure compatibility of the Hose tube, cover, reinforcement, Tube, Plating and Seals with the fluid media used. See the fluid compatibility chart in the Parker publication for the product being considered or used. This information is offered only as a guide. Actual service life can only be determined by the end user by testing under all extreme conditions and other analysis. Hose, and Tube that is chemically compatible with a particular fluid must be assembled using Fittings and adapters containing likewise compatible seals. Flange or flare processes can change Tube material properties that may not be compatible with certain requirements such as NACE

2.6 Permeation: Permeation (that is, seepage through the Hose or Seal) will occur from inside the Hose or Fitting to outside when Hose or Fitting is used with gases, liquid and gas fuels, and refrigerants (including but not limited to such materials as helium, diesel fuel, gasoline,

natural gas, or LPG). This permeation may result in high concentrations of vapors which are potentially flammable, explosive, or toxic, and in loss of fluid. Dangerous explosions, fires, and other hazards can result when using the wrong Hose for such applications. The system designer must take into account the fact that this permeation will take place and must not use Hose or Fitting if this permeation could be hazardous. The system designer must take into account all legal, government, insurance, or any other special regulations which govern the use of fuels and refrigerants. Never use a Hose or Fitting even though the fluid compatibility is acceptable without considering the potential hazardous effects that can result from permeation through the Hose or Tube Assembly. Permeation of moisture from outside the Hose or Fitting to inside the Hose or Fitting will also occur in Hose or Tube assemblies, regardless of internal pressure. If this moisture permeation would have detrimental effects (particularly, but not limited to refrigeration and air conditioning systems), incorporation of sufficient drying capacity in the system or other appropriate system safeguards should be selected and used. The sudden pressure release of highly pressurized gas could also result in Explosive Decompression failure of permeated Seals and Hoses.

2.7 Size: Transmission of power by means of pressurized fluid varies with pressure and rate of flow. The size of the components must be adequate to keep pressure losses to a minimum and avoid damage due to heat generation or excessive fluid velocity. .

2.8 Routing: Attention must be given to optimum routing to minimize inherent problems (kinking or flow restriction due to Hose collapse, twisting of the Hose, proximity to hot objects or heat sources). For additional routing recommendations see SAE J1273 and ISO 17165-2. Hose Assemblies have a finite life and should be installed in a manner that allows for ease of inspection and future replacement. Hose because of its relative short life, should not be used in residential and commercial buildings inside of inaccessible walls or floors, unless specifically allowed in the product literature. Always review all product literature for proper installation and routing instructions.

2.9 Environment: Care must be taken to insure that the Hose, Tube and Fittings are either compatible with or protected from the environment (that is, surrounding conditions) to which they are exposed. Environmental conditions including but not limited to ultraviolet radiation, sunlight, heat, ozone, moisture, water, salt water, chemicals and air pollutants can cause degradation and premature failure.

2.10 Mechanical Loads: External forces can significantly reduce Hose, Tube and Fitting life or cause failure. Mechanical loads which must be considered include excessive flexing, twist, kinking, tensile or side loads, bend radius, and vibration. Use of swivel type Fittings or adapters may be required to insure no twist is put into the Hose. Use of proper Hose or Tube clamps may also be required to reduce external mechanical loads. Unusual applications may require special testing prior to Hose selection.

2.11 Physical Damage: Care must be taken to protect Hose from wear, snagging, kinking, bending smaller than minimum bend radius and cutting, any of which can cause premature Hose failure. Any Hose that has been kinked or bent to a radius smaller than the minimum bend radius, and any Hose that has been cut or is cracked or is otherwise damaged should be removed and discarded. Fittings with damages such as scratches on sealing surfaces and deformation should be replaced.

2.12 Proper End Fitting: See instructions 3.2 through 3.5. These recommendations may be substantiated by testing to industry standards such as SAE J517 for hydraulic applications, or MIL-A-5070, AS1339, or AS3517 for Hoses from Parker's Stratoflex Products Division for aerospace applications.

2.13 Length: When determining the proper Hose or Tube length of an assembly, be aware of Hose length change due to pressure, Tube length change due to thermal expansion or contraction, and Hose or Tube and machine tolerances and movement must be considered. When routing short hose assemblies, it is recommended that the minimum free hose length is always used. Consult the hose manufacturer for their minimum free hose length recommendations. Hose assemblies should be installed in such a way that any motion or flexing occurs within the same plane.

2.14 Specifications and Standards: When selecting Hose, Tube and Fittings, government, industry, and Parker specifications and recommendations must be reviewed and followed as applicable.

2.15 Hose Cleanliness: Hose and Tube components may vary in cleanliness levels. Care must be taken to insure that the Hose and Tube Assembly selected has an adequate level of cleanliness for the application.

Parker safety guide

2.16 Fire Resistant Fluids: Some fire resistant fluids that are to be conveyed by Hose or Tube require use of the same type of Hose or Tube as used with petroleum base fluids. Some such fluids require a special Hose, Tube, Fitting and Seal, while a few fluids will not work with any Hose at all. See instructions 2.5 and 1.5. The wrong Hose, Tube, Fitting or Seal may fail after a very short service. In addition, all liquids but pure water may burn fiercely under certain conditions, and even pure water leakage may be hazardous.

2.17 Radiant Heat: Hose and Seals can be heated to destruction without contact by such nearby items as hot manifolds or molten metal. The same heat source may then initiate a fire. This can occur despite the presence of cool air around the Hose or Seal. Performance of Tube and Fitting subjected to the heat could be degraded.

2.18 Welding or Brazing: When using a torch or arc welder in close proximity to hydraulic lines, the hydraulic lines should be removed or shielded with appropriate fire resistant materials. Flame or weld spatter could burn through the Hose or Seal and possibly ignite escaping fluid resulting in a catastrophic failure. Heating of plated parts, including Hose Fittings and adapters, above 450°F (232°C) such as during welding, brazing or soldering may emit deadly gases. Any elastomer seal on fittings shall be removed prior to welding or brazing, any metallic surfaces shall be protected after brazing or welding when necessary. Welding and brazing filler material shall be compatible with the Tube and Fitting that are joined.

2.19 Atomic Radiation: Atomic radiation affects all materials used in Hose and Tube assemblies. Since the long-term effects may be unknown, do not expose Hose or Tube assemblies to atomic radiation. Nuclear applications may require special Tube and Fittings.

2.20 Aerospace Applications: The only Hose, Tube and Fittings that may be used for in-flight aerospace applications are those available from Parker's Stratoflex Products Division. Do not use any other Hose or Fittings for in-flight applications. Do not use any Hose or Fittings from Parker's Stratoflex Products Division with any other Hose or Fittings, unless expressly approved in writing by the engineering manager or chief engineer of Stratoflex Products Division and verified by the user's own testing and inspection to aerospace industry standards.

2.21 Unlocking Couplings: Ball locking couplings or other Fittings with quick disconnect ability can unintentionally disconnect if they are dragged over obstructions, or if the sleeve or other disconnect member, is bumped or moved enough to cause disconnect. Threaded Fittings should be considered where there is a potential for accidental uncoupling.

3.0 HOSE AND FITTINGS ASSEMBLY AND INSTALLATION INSTRUCTIONS

3.1 Component Inspection: Prior to assembly, a careful examination of the Hose and Fittings must be performed. All components must be checked for correct style, size, catalog number, and length. The Hose must be examined for cleanliness, obstructions, blisters, cover looseness, kinks, cracks, cuts or any other visible defects. Inspect the Fitting and sealing surfaces for burrs, nicks, corrosion or other imperfections. Do NOT use any component that displays any signs of nonconformance.

3.2 Hose and Fitting Assembly: Do not assemble a Parker Fitting on a Parker Hose that is not specifically listed by Parker for that Fitting, unless authorized in writing by the engineering manager or chief engineer of the appropriate Parker division. Do not assemble a Parker Fitting on another manufacturer's Hose or a Parker Hose on another manufacturer's Fitting unless (i) the engineering manager or chief engineer of the appropriate Parker division approves the Assembly in writing or that combination is expressly approved in the appropriate Parker literature for the specific Parker product, and

(ii) the user verifies the Assembly and the application through analysis and testing. For Parker Hose that does not specify a Parker Fitting, the user is solely responsible for the selection of the proper Fitting and Hose Assembly procedures. See instruction 1.4. To prevent the possibility of problems such as leakage at the Fitting or system contamination, it is important to completely remove all debris from the cutting operation before installation of the Fittings. The Parker published instructions must be followed for assembling the Fittings on the Hose. These instructions are provided in the Parker Fitting catalog for the specific Parker Fitting being used, or by calling 1-800-CPARKER, or at www.parker.com.

3.3 Related Accessories: Do not crimp or swage any Parker Hose or Fitting with anything but the listed swage or crimp machine and dies in accordance with Parker published instructions. Do not crimp

or swage another manufacturer's Fitting with a Parker crimp or swage die unless authorized in writing by the engineering manager or chief engineer of the appropriate Parker division.

3.4 Parts: Do not use any Parker Fitting part (including but not limited to socket, shell, nipple, or insert) except with the correct Parker mating parts, in accordance with Parker published instructions, unless authorized in writing by the engineering manager or chief engineer of the appropriate Parker division.

3.5 Field Attachable/Permanent: Do not reuse any field attachable Hose Fitting that has blown or pulled off a Hose. Do not reuse a Parker permanent Hose Fitting (crimped or swaged) or any part thereof. Complete Hose Assemblies may only be reused after proper inspection under section 4.0. Do not assemble Fittings to any previously used hydraulic Hose that was in service, for use in a fluid power application.

3.6 Pre-Installation Inspection: Prior to installation, a careful examination of the Hose Assembly must be performed. Inspect the Hose Assembly for any damage or defects. DO NOT use any Hose Assembly that displays any signs of nonconformance.

3.7 Minimum Bend Radius: Installation of a Hose at less than the minimum listed bend radius may significantly reduce the Hose life. Particular attention must be given to preclude sharp bending at the Hose to Fitting juncture. Any bending during installation at less than the minimum bend radius must be avoided. If any Hose is kinked during installation, the Hose must be discarded.

3.8 Twist Angle and Orientation: Hose Assembly installation must be such that relative motion of machine components does not produce twisting.

3.9 Securement: In many applications, it may be necessary to restrain, protect, or guide the Hose to protect it from damage by unnecessary flexing, pressure surges, and contact with other mechanical components. Care must be taken to insure such restraints do not introduce additional stress or wear points.

3.10 Proper Connection of Ports: Proper physical installation of the Hose Assembly requires a correctly installed port connection insuring that no twist or torque is transferred to the Hose when the Fittings are being tightened or otherwise during use.

3.11 External Damage: Proper installation is not complete without insuring that tensile loads, side loads, kinking, flattening, potential abrasion, thread damage or damage to sealing surfaces are corrected or eliminated. See instruction 2.10.

3.12 System Checkout: All air entrapment must be eliminated and the system pressurized to the maximum system pressure (at or below the Hose maximum working pressure) and checked for proper function and freedom from leaks. Personnel must stay out of potential hazardous areas while testing and using.

3.13 Routing: The Hose Assembly should be routed in such a manner so if a failure does occur, the escaping media will not cause personal injury or property damage. In addition, if fluid media comes in contact with hot surfaces, open flame or sparks, a fire or explosion may occur. See section 2.4.

3.14 Ground Fault Equipment Protection Devices (GFEPDs): WARNING! Fire and Shock Hazard. To minimize the danger of fire if the heating cable of a Multitube bundle is damaged or improperly installed, use a Ground Fault Equipment Protection Device. Electrical fault currents may be insufficient to trip a conventional circuit breaker. For ground fault protection, the IEEE 515: (www.ansi.org) standard for heating cables recommends the use of GFEPDs with a nominal 30 milliampere trip level for "piping systems in classified areas, those areas requiring a high degree of maintenance, or which may be exposed to physical abuse or corrosive atmospheres".

4.0 TUBE AND FITTINGS ASSEMBLY AND INSTALLATION INSTRUCTIONS

4.1 Component Inspection: Prior to assembly, a careful examination of the Tube and Fittings must be performed. All components must be checked for correct style, size, material, seal, and length. Inspect the Fitting and sealing surfaces for burrs, nicks, corrosion, missing seal or other imperfections. Do NOT use any component that displays any signs of nonconformance.

4.2 Tube and Fitting Assembly: Do not assemble a Parker Fitting with a Tube that is not specifically listed by Parker for that Fitting, unless authorized in writing by the engineering manager or chief engineer of the appropriate Parker division. The Tube must meet the requirements specified to the Fitting. The Parker published instructions must be followed for assembling the Fittings to a Tube. These instructions

are provided in the Parker Fitting catalog for the specific Parker Fitting being used, or by calling 1-800-CPARKER, or at www.parker.com.

4.3 Related Accessories: Do not preset or flange Parker Fitting components using another manufacturer's equipment or procedures unless authorized in writing by the engineering manager or chief engineer of the appropriate Parker division. Tube, Fitting component and tooling must be checked for correct style, size and material. Operation and maintenance of Related Accessories must be in accordance with the operation manual for the designated Accessory.

4.4 Securement: In many applications, it may be necessary to restrain, protect, or guide the Tube to protect it from damage by unnecessary flexing, pressure surges, vibration, and contact with other mechanical components. Care must be taken to insure such restraints do not introduce additional stress or wear points.

4.5 Proper Connection of Ports: Proper physical installation of the Tube Assembly requires a correctly installed port connection insuring that no torque is transferred to the Tube when the Fittings are being tightened or otherwise during use.

4.6 External Damage: Proper installation is not complete without insuring that tensile loads, side loads, flattening, potential abrasion, thread damage or damage to sealing surfaces are corrected or eliminated. See instruction 2.10.

4.7 System Checkout: All air entrapment must be eliminated and the system pressurized to the maximum system pressure (at or below the Tube Assembly maximum working pressure) and checked for proper function and freedom from leaks. Personnel must stay out of potential hazardous areas while testing and using.

Routing: The Tube Assembly should be routed in such a manner so if a failure does occur, the escaping media will not cause personal injury or property damage. In addition, if fluid media comes in contact with hot surfaces, open flame or sparks, a fire or explosion may occur. See section 2.4.

5.0 HOSE AND FITTING MAINTENANCE AND REPLACEMENT INSTRUCTIONS

5.1 Even with proper selection and installation, Hose life may be significantly reduced without a continuing maintenance program. The severity of the application, risk potential from a possible Hose failure, and experience with any Hose failures in the application or in similar applications should determine the frequency of the inspection and the replacement for the Products so that Products are replaced before any failure occurs. Certain products require maintenance and inspection per industry requirements. Failure to adhere to these requirements may lead to premature failure. A maintenance program must be established and followed by the user and, at minimum, must include instructions 5.2 through 5.7.

5.2 Visual Inspection Hose/Fitting: Any of the following conditions require immediate shut down and replacement of the Hose Assembly:

- Fitting slippage on Hose;
- Damaged, cracked, cut or abraded cover (any reinforcement exposed);
- Hard, stiff, heat cracked, or charred Hose;
- Cracked, damaged, or badly corroded Fittings;
- Leaks at Fitting or in Hose;
- Kinked, crushed, flattened or twisted Hose; and
- Blistered, soft, degraded, or loose cover.

5.3 Visual Inspection All Other: The following items must be tightened, repaired, corrected or replaced as required:

- Leaking port conditions;
- Excess dirt buildup;
- Worn clamps, guards or shields; and
- System fluid level, fluid type, and any air entrapment.

5.4 Functional Test: Operate the system at maximum operating pressure and check for possible malfunctions and leaks. Personnel must avoid potential hazardous areas while testing and using the system. See section 2.2.

5.5 Replacement Intervals: Hose assemblies and elastomeric seals used on Hose Fittings and adapters will eventually age, harden, wear and deteriorate under thermal cycling and compression set. Hose Assemblies and elastomeric seals should be inspected and replaced at specific replacement intervals, based on previous service life, government or industry recommendations, or when failures could result in unacceptable downtime, damage, or injury risk. See section 1.2. Hose and Fittings may be subjected to internal mechanical and/or chemical wear from the conveying fluid and may fail without warning. The user must determine the product life under such circumstances by testing. Also see section 2.5.

5.6 Hose Inspection and Failure: Hydraulic power is accomplished by utilizing high pressure fluids to transfer energy and do work. Hoses, Fittings and Hose Assemblies all contribute to this by transmitting fluids at high pressures. Fluids under pressure can be dangerous and potentially lethal and, therefore, extreme caution must be exercised when working with fluids under pressure and handling the Hoses transporting the fluids. From time to time, Hose Assemblies will fail if they are not replaced at proper time intervals. Usually these failures are the result of some form of misapplication, abuse, wear or failure to perform proper maintenance. When Hoses fail, generally the high pressure fluids inside escape in a stream which may or may not be visible to the user. Under no circumstances should the user attempt to locate the leak by "feeling" with their hands or any other part of their body. High pressure fluids can and will penetrate the skin and cause severe tissue damage and possibly loss of limb. Even seemingly minor hydraulic fluid injection injuries must be treated immediately by a physician with knowledge of the tissue damaging properties of hydraulic fluid.

If a Hose failure occurs, immediately shut down the equipment and leave the area until pressure has been completely released from the Hose Assembly. Simply shutting down the hydraulic pump may or may not eliminate the pressure in the Hose Assembly. Many times check valves, etc., are employed in a system and can cause pressure to remain in a Hose Assembly even when pumps or equipment are not operating. Tiny holes in the Hose, commonly known as pinholes, can eject small, dangerously powerful but hard to see streams of hydraulic fluid. It may take several minutes or even hours for the pressure to be relieved so that the Hose Assembly may be examined safely. Once the pressure has been reduced to zero, the Hose Assembly may be taken off the equipment and examined. It must always be replaced if a failure has occurred. Never attempt to patch or repair a Hose Assembly that has failed. Consult the nearest Parker distributor or the appropriate Parker division for Hose Assembly replacement information. Never touch or examine a failed Hose Assembly unless it is obvious that the Hose no longer contains fluid under pressure. The high pressure fluid is extremely dangerous and can cause serious and potentially fatal injury.

5.7 Elastomeric seals: Elastomeric seals will eventually age, harden, wear and deteriorate under thermal cycling and compression set. Elastomeric seals should be inspected and replaced.

5.8 Refrigerant gases: Special care should be taken when working with refrigeration systems. Sudden escape of refrigerant gases can cause blindness if the escaping gases contact the eye and can cause freezing or other severe injuries if it contacts any other portion of the body.

5.9 Compressed natural gas (CNG): Parker CNG Hose Assemblies should be tested after installation and before use, and at least on a monthly basis per instructions provided on the Hose Assembly tag. The recommended procedure is to pressurize the Hose and check for leaks and to visually inspect the Hose for damage and to perform an electrical resistance test.

Caution: Matches, candles, open flame or other sources of ignition shall not be used for Hose inspection. Leak check solutions should be rinsed off after use.

6.0 HOSE STORAGE

6.1 Age Control: Hose and Hose Assemblies must be stored in a manner that facilitates age control and first-in and first-out usage based on manufacturing date of the Hose and Hose Assemblies. Unless otherwise specified by the manufacturer or defined by local laws and regulations:

6.1.1 The shelf life of rubber hose in bulk form or hose made from two or more materials is 28 quarters (7 years) from the date of manufacture, with an extension of 12 quarters (3 years), if stored in accordance with ISO 2230;

6.1.2 The shelf life of thermoplastic and polytetrafluoroethylene hose is considered to be unlimited;

6.1.3 Hose assemblies that pass visual inspection and proof test shall not be stored for longer than 2 years.

6.1.4 Storage: Stored Hose and Hose Assemblies must not be subjected to damage that could reduce their expected service life and must be placed in a cool, dark and dry area with the ends capped. Stored Hose and Hose Assemblies must not be exposed to temperature extremes, ozone, oils, corrosive liquids or fumes, solvents, high humidity, rodents, insects, ultraviolet light, electromagnetic fields or radioactive materials.

Technical data

| Technical data | |
|-------------------------------------------------------------|---------------|
| Hose overview | Ab-2 – Ab-4 |
| Hose fittings overview | Ab-5 – Ab-8 |
| Hose fittings pressure ratings | Ab-9 – Ab-11 |
| Hose fittings nomenclature | Ab-12 – Ab-15 |
| Classification bodies | Ab-16 |
| Approvals for Parker hydraulic hoses | Ab-17 – Ab-19 |
| Conversion chart | Ab-20 |
| Temperature and pressure chart | Ab-21 |
| Flow capacity nomogram | Ab-22 |
| The correct method to fit female swivel ends | Ab-23 |
| The correct method to fit ISO 6162-1 and ISO 6162-2 flanges | Ab-24 – Ab-25 |
| Chemical resistance table | Ab-26 – Ab-34 |

| Hose overview | Hose | Fitting serie | Working Pressure (MPa) at size / DN | | | | | | | | | | | | | | | | Temp. °C | Construction | Standard | |
|------------------|--------------|---------------|-------------------------------------|------|------|------|------|------|-----|-----|-----|-----|-----|-----|-----|-----|-----|-----|----------|----------------|---------------------------|-----|
| | | | -3 | -4 | -5 | -6 | -8 | -10 | -12 | -16 | -20 | -24 | -32 | -40 | -48 | -56 | -64 | -80 | | | | -96 |
| Low pressure | Multipurpose | 801Plus | 5 | 6 | 8 | 10 | 12 | 16 | 19 | 25 | 31 | 38 | 51 | 63 | 76 | 90 | 100 | 125 | 150 | -40/+100 | 1 braid, fibre | |
| | | 830M | | 2.4 | | 2.4 | 2.1 | 2.1 | 2.1 | 1.4 | | | | | | | | | | -40/+80 | 1 braid, fibre | |
| | | 837BM | | 1.6 | | 1.6 | 1.6 | 1.6 | 1.6 | 1.6 | | | | | | | | | | -40/+100 | 1 braid, fibre | |
| | | 837PU | | 1.6 | | 1.6 | 1.6 | 1.6 | 1.6 | 1.6 | | | | | | | | | | -40/+100 | 1 braid, fibre | |
| Push-Lok | 801RH | 82 | 2.4 | | | 2.4 | | | | | | | | | | | | | -40/+100 | 1 braid, fibre | | |
| | 804 | 82 | 1.0 | | | 1.0 | 1.0 | 1.0 | 1.0 | | | | | | | | | | -40/+80 | 1 braid, fibre | | |
| High temperature | 821FR | 82 | 2.4 | | | 2.1 | 2.1 | 1.7 | | | | | | | | | | | -40/+100 | 1 braid, fibre | | |
| | 836 | 82 | 2.8 | | | 2.8 | 2.8 | 2.4 | 2.1 | | | | | | | | | | -48/+150 | 1 braid, fibre | | |
| | 846 | 82 | 1.6 | | | 1.6 | 1.6 | 1.6 | 1.6 | | | | | | | | | | -48/+150 | 1 braid, fibre | | |
| | 838M | 82 | 1.6 | | | 1.6 | 1.6 | 1.6 | 1.6 | | | | | | | | | | -40/+80 | 1 braid, fibre | | |
| Non-conductive | 681 | 47 | 7.5 | 6.8 | 6.3 | 5.8 | 5.0 | 4.5 | 4.0 | | | | | | | | | | -40/+100 | 1 braid, fibre | EN 854-2TE | |
| | 611HT | 47 | 2.8 | 2.8 | 2.8 | 2.8 | 2.4 | 2.1 | 2.0 | | | | | | | | | | -40/+150 | 1 braid, fibre | EN 854-R6 | |
| High temperature | 681DB | 47 | 7.5 | 6.8 | 6.3 | 5.8 | 5.0 | 4.5 | 4.0 | | | | | | | | | | -40/+100 | 1 braid, fibre | EN 854-2TE | |
| | 201 | 26 | 20.7 | 20.7 | 15.5 | 13.8 | 12.0 | 10.3 | 5.5 | 4.3 | 3.5 | 2.4 | | | | | | | -40/+150 | 1 braid, fibre | SAE 100R5 - SAE J1402 All | |
| Transportation | 206 | 26 | 20.7 | 20.7 | 15.5 | 13.8 | 12.0 | 10.3 | 5.5 | 4.3 | 3.5 | 2.4 | | | | | | | -48/+150 | 1 braid, fibre | SAE 100R5 - SAE J1402 All | |
| | 213 | 26 | 13.8 | 10.3 | 10.3 | 8.6 | 6.9 | 5.2 | 2.8 | 2.1 | 1.7 | 1.4 | | | | | | | -45/+150 | 1 braid, fibre | SAE J1402 AI | |
| | 293 | 26 | 3.5 | | | 3.5 | 3.5 | 3.1 | 3.1 | | | | | | | | | | -50/+150 | 1 braid, fibre | SAE J1402 AI | |
| Fire retardant | 221FR | 26 | | | | 3.5 | 3.5 | 3.5 | 3.5 | 3.5 | | | | | | | | | -20/+100 | 1 braid, wire | SAE J1527 R3 | |
| | 285 | 26 | | | | 3.4 | 3.4 | 3.4 | 3.4 | 3.4 | | | | | | | | | -30/+125 | 1 braid, fibre | SAE J3062 Type C | |
| Refrigeration | 244 | 26 | | | | 3.4 | 3.4 | 3.4 | 3.4 | 3.4 | | | | | | | | | -30/+125 | 1 braid, wire | SAE J2064 B Class I | |

in parentheses (""): The fitting series depends on the hose ID (size). For details, please refer to the respective hose page in this catalogue

| Hose overview High pressure | Hose | Fitting serie | Working Pressure (MPa) at size / DN/ | | | | | | | | | | | | | | | | | | | Temp. °C | Construction | Standard | | |
|---------------------------------------------------------|------------------|---------------|----------------------------------------------------------------|------|------|------|------|------|-------|-------|------|------|------|------|------|------|-----|-----|-----|-----|-----|----------|--------------|-------------------------------|-----------------------------------------------------|--------------------------------------------------|
| | | | -3 -4 -5 -6 -8 -10 -12 -16 -20 -24 -32 -40 -48 -56 -64 -80 -96 | | | | | | | | | | | | | | | | | | | | | | | |
| | | | 5 | 6 | 8 | 10 | 12 | 16 | 19 | 25 | 31 | 38 | 51 | 63 | 76 | 90 | 100 | 125 | 150 | 175 | 210 | | | | | |
| GlobalCore | 722 | 43 | | | | | | | 28.0 | 28.0 | 28.0 | 28.0 | 28.0 | 28.0 | 28.0 | | | | | | | | | -40/+100 | 4 spiral, wire | Exceeds ISO 18752-BC |
| | 722TC | 43 | | | | | | | 28.0 | 28.0 | 28.0 | 28.0 | 28.0 | 28.0 | 28.0 | | | | | | | | | -40/+125 | 4 spiral, wire | Exceeds ISO 18752-CC |
| | 722ST | 43 | | | | | | | 28.0 | 28.0 | 28.0 | 28.0 | 28.0 | 28.0 | 28.0 | | | | | | | | | -40/+125 | 4 spiral, wire | Exceeds ISO 18752-CC |
| | 787 | (43, 48, 77) | 35.0 | 35.0 | 35.0 | 35.0 | 35.0 | 35.0 | 35.0 | 35.0 | 35.0 | 35.0 | 35.0 | 35.0 | 35.0 | 35.0 | | | | | | | | -40/+100 | 4/6 spiral, wire ¹ | Exceeds ISO 18752-BC |
| | 787TC | (43, 48, 77) | 35.0 | 35.0 | 35.0 | 35.0 | 35.0 | 35.0 | 35.0 | 35.0 | 35.0 | 35.0 | 35.0 | 35.0 | 35.0 | 35.0 | | | | | | | | -40/+125 | 4/6 spiral, wire ¹ | Exceeds ISO 18752-DC |
| | 787ST | (43, 48, 77) | 35.0 | 35.0 | 35.0 | 35.0 | 35.0 | 35.0 | 35.0 | 35.0 | 35.0 | 35.0 | 35.0 | 35.0 | 35.0 | 35.0 | | | | | | | | -40/+125 | 4/6 spiral, wire ¹ | Exceeds ISO 18752-DC |
| | 797 | (43, 48, 77) | 42.0 | 42.0 | 42.0 | 42.0 | 42.0 | 42.0 | 42.0 | 42.0 | 42.0 | 42.0 | 42.0 | 42.0 | 42.0 | 42.0 | | | | | | | | -40/+100 | 4/6 spiral, wire ¹ | Exceeds ISO 18752-BC |
| | 797TC | (43, 48, 77) | 42.0 | 42.0 | 42.0 | 42.0 | 42.0 | 42.0 | 42.0 | 42.0 | 42.0 | 42.0 | 42.0 | 42.0 | 42.0 | 42.0 | | | | | | | | -40/+125 | 4/6 spiral, wire ¹ | Exceeds ISO 18752-DC - ISO 18752-CC ² |
| | 797ST | (43, 48, 77) | 42.0 | 42.0 | 42.0 | 42.0 | 42.0 | 42.0 | 42.0 | 42.0 | 42.0 | 42.0 | 42.0 | 42.0 | 42.0 | 42.0 | | | | | | | | -40/+125 | 4/6 spiral, wire ¹ | Exceeds ISO 18752-DC - ISO 18752-CC ² |
| | 372 | 70 | | | | | | | | 44.5 | 41.5 | 35.0 | 35.0 | 28.0 | | | | | | | | | | -40/+100 | 3 braids, wire | |
| Low temperature High abr. resist. MSHA Railway | 371LT | 70 | | | | | | | 44.5 | 41.5 | 35.0 | 35.0 | 28.0 | | | | | | | | | | -50/+100 | 3 braids, wire | | |
| | 372TC | 70 | | | | | | | 44.5 | 41.5 | 35.0 | 35.0 | 28.0 | | | | | | | | | | -40/+100 | 3 braids, wire | | |
| | 372RH | 70 | | | | | | | 44.5 | 41.5 | 35.0 | 35.0 | 28.0 | | | | | | | | | | -40/+100 | 3 braids, wire | | |
| Standard | SX35 | 73 | | | | | | | | | 35.0 | 35.0 | 35.0 | | | | | | | | | | -40/+125 | 4 spiral, wire | ISO 3862 Typ R13 | |
| | SX42 | (73, 77) | | | | | | | | | 42.0 | 42.0 | 42.0 | | | | | | | | | | -40/+125 | 4/6 spiral, wire ¹ | ISO 3862 Typ R15 | |
| | 701 | 70 | | | | | | | 45.0 | 41.5 | 35.0 | 35.0 | 28.0 | | | | | | | | | | -40/+100 | 4 spiral, wire | Exceeds EN 856-4SP - ISO 3862-4SP | |
| | 731 | 73 | | | | | | | | | 42.0 | 38.0 | 32.5 | 29.0 | 25.0 | | | | | | | | | -40/+100 | 4 spiral, wire | Exceeds EN 856-4SH - ISO 3862-4SH |
| | SX35LT SX42LT | (73, 77) | | | | | | | | | 35.0 | 35.0 | 35.0 | | | | | | | | | | -57/+100 | 4/6 spiral, wire ¹ | | |
| Phosphat-Ester | 774 | ⊕ | | | | | | | | | 28.0 | 28.0 | 21.0 | 17.5 | 17.5 | | | | | | | | | -40/+80 | 4 spiral, wire | ISO 3862-R15 - SAE 100R15 |
| | F42 | (70) | | | | | | | 42.0 | | 42.0 | 42.0 | 42.0 | | | | | | | | | | -40/+80 | 4/6 spiral, wire ¹ | | |
| | SX35TC | 73 | | | | | | | | | 35.0 | 35.0 | 35.0 | | | | | | | | | | -40/+125 | 4 spiral, wire | ISO 3862 Typ R13 | |
| | SX42TC | (73, 77) | | | | | | | | | 42.0 | 42.0 | 42.0 | | | | | | | | | | -40/+125 | 4/6 spiral, wire ¹ | ISO 3862 Typ R15 | |
| High abrasion resistance MSHA approved | 701TC | 70 | | | | | | | 45.0 | 41.5 | 35.0 | 35.0 | 28.0 | | | | | | | | | | -40/+100 | 4 spiral, wire | EN 856-4SP - ISO 3862-4SP | |
| | 731TC | 73 | | | | | | | | | 42.0 | 38.0 | 32.5 | 29.0 | 25.0 | | | | | | | | -40/+125 | 4 spiral, wire | ISO 3862-4SH - EN 856-4SH | |
| | 797RH | 77 | | | | | | | | | 42.0 | 42.0 | 42.0 | 42.0 | | | | | | | | | -40/+125 | 4/6 spiral, wire ¹ | Exceeds SAE 100R15 - ISO 3862-R15 - ISO 18752-DC/CC | |
| Standard | H31 | (NS, V4) | 50.0 | | | | | | 44.5 | 41.5 | 39.0 | 35.0 | 31.0 | | | | | | | | | | -40/+100 | 4 spiral, wire | Exceeds EN 856-4SP - ISO 3862-4SP | |
| | H29 | V4 | | | | | | | | | 43.0 | 40.0 | 35.0 | 31.0 | 28.0 | | | | | | | | -40/+100 | 4 spiral, wire | Exceeds EN 856-4SH - ISO 3862-4SH | |
| | R35 | (V4, V6) | | | | | | | | | 35.0 | 35.0 | 35.0 | 35.0 | 35.0 | | | | | | | | -40/+125 | 4/6 spiral, wire ¹ | EN 856-R13 - ISO 3862-R13 - SAE 100R13 | |
| | R42 | (V4, V6) | | | | | | | | | 42.0 | 42.0 | 42.0 | 42.0 | 42.0 | | | | | | | | -40/+125 | 4/6 spiral, wire ¹ | ISO 3862-R15 - SAE 100R15 | |
| | H31TC | (NS, V4) | 50.0 | | | | | | 44.5 | 41.5 | 39.0 | 35.0 | 31.0 | | | | | | | | | | -40/+100 | 4 spiral, wire | Exceeds EN 856-4SP - ISO 3862-4SP | |
| | H29TC | V4 | | | | | | | | | 43.0 | 40.0 | 35.0 | 31.0 | 28.0 | | | | | | | | -40/+100 | 4 spiral, wire | Exceeds EN 856-4SH - ISO 3862-4SH | |
| | R35TC | (V4, V6) | | | | | | | | | 35.0 | 35.0 | 35.0 | 35.0 | 35.0 | 35.0 | | | | | | | -40/+125 | 4/6 spiral, wire ¹ | EN 856-R13 - ISO 3862-R13 - SAE 100R13 | |
| High abrasion resistance MSHA approved ParLock | RD35TC | V6 | | | | | | | | | 35.0 | 35.0 | 35.0 | 35.0 | 35.0 | | | | | | | | -20/+100 | 6 spiral, wire | Exceeds ISO 3862 Typ R13 | |
| | RS35TC | V6 | | | | | | | | | 35.0 | 35.0 | 35.0 | 35.0 | 35.0 | | | | | | | | -40/+125 | 6 spiral, wire | ISO 6907-D | |
| | R42TC | (V4, V6) | | | | | | | | | 42.0 | 42.0 | 42.0 | 42.0 | 42.0 | | | | | | | | -40/+125 | 4/6 spiral, wire ¹ | ISO 3862-R15 - SAE 100R15 | |
| | R50TC | (V4, V6) | | | | | | | | | 50.0 | 50.0 | 50.0 | 50.0 | | | | | | | | | -40/+100 | 4/6 spiral, wire ¹ | Exceeds ISO 3862-R15 | |
| | R56TC | V5 | | | | | | | | | 56.0 | 56.0 | | | | | | | | | | | -40/+100 | 4 spiral, wire | Exceeds ISO 3862-R15 | |
| | H31ST | (NS, V4) | 50.0 | | | | | | 44.5 | 41.5 | 39.0 | 35.0 | 31.0 | | | | | | | | | | -40/+100 | 4 spiral, wire | Exceeds EN 856-4SP - ISO 3862-4SP | |
| | H29ST | V4 | | | | | | | | | 43.0 | 40.0 | 35.0 | 31.0 | 28.0 | | | | | | | | -40/+100 | 4 spiral, wire | Exceeds EN 856-4SH - ISO 3862-4SH | |
| | R42ST | (V4, V6) | | | | | | | | | 42.0 | 42.0 | 42.0 | 42.0 | 42.0 | | | | | | | | -40/+125 | 4/6 spiral, wire ¹ | ISO 3862-R15 - SAE 100R15 | |
| Water-Blasting Firearm BOP Cementing | BPK | WB | | | | | | | 110.0 | 110.0 | | | | | | | | | | | | | @ | 4/6 spiral, wire ¹ | DIN EN 1829-2 | |
| | FA35 | (V4, V6, V5) | | | | | | | | | 35.0 | 35.0 | 35.0 | 35.0 | 35.0 | | | | | | | | -40/+100 | 4/6 spiral, wire ¹ | | |
| | CEM69TC | V6 | | | | | | | | | | | | | | | | | | | | | -20/+100 | 6 spiral, wire | API 7K FSLD - ISO 14693 | |

@: on request; in parentheses "()": The fitting series depends on the hose ID (size).

1: The hose construction depends on the hose ID (size). 2: The standard depends on the hose ID (size).

3: Max. temperature +125 / +100° C. depends on the hose ID (size).

For details, please refer to the respective hose page in this catalogue.

@ Continuous service temperature range -10 °C up to +70 °C

* 2.1 MPa: Dynamic hydraulic application design factor > 4:1

* 3.5 MPa: Static applications according to ISO 6807-D

Fittings overview

DIN – Metric



BSP

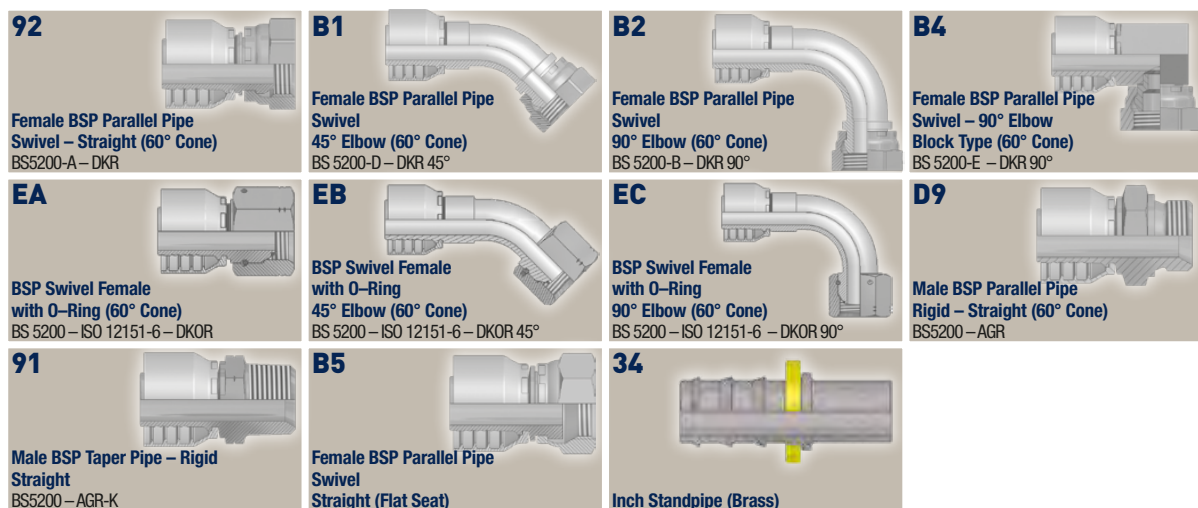



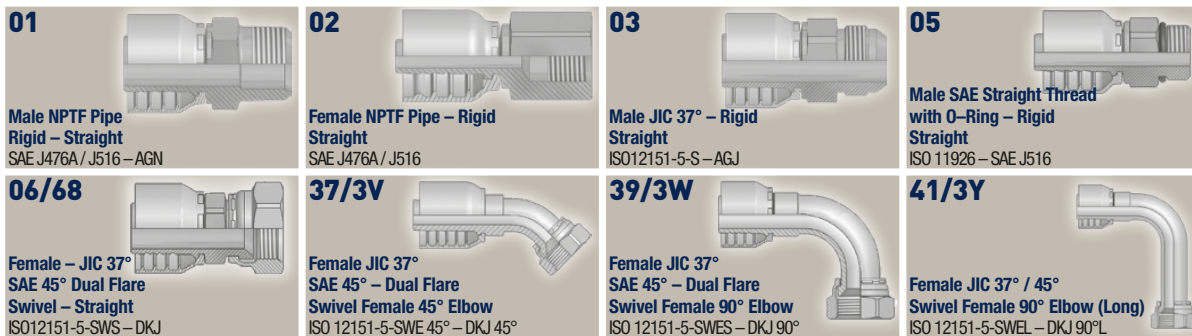

SAE

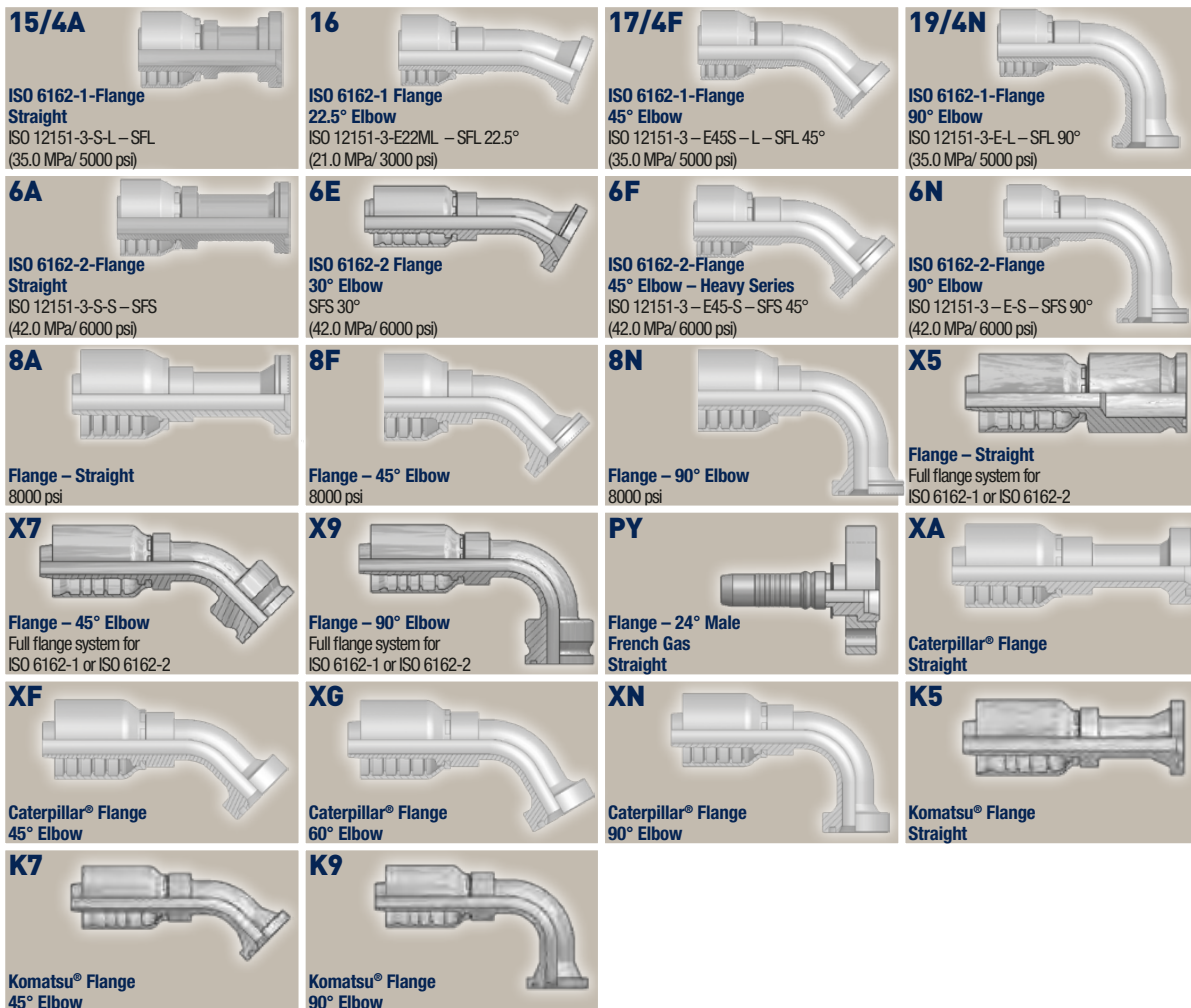

Flange

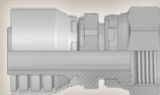
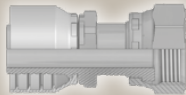

ORFS

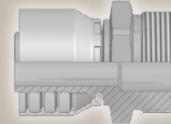
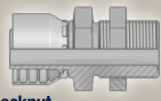
| | | | |
|----------------------------------------------------------------------------------------------------------------------------------------------------------------------------------------------------------|---------------------------------------------------------------------------------------------------------------------------------------------------------------------------------------------------|------------------------------------------------------------------------------------------------------------------------------------------------------------------------------------------------|-----------------------------------------------------------------------------------------------------------------------------------------------------------------------------------------------------------|
| <p>JC</p>  <p>Female ORFS Swivel - Straight Short ISO 12151-1 - SWSA SAE J516 - ORFS</p> | <p>JS</p>  <p>ORFS Swivel Female (Long) ISO 12151-1 - SWSB SAE J516 - ORFS</p> | <p>J7</p>  <p>Female ORFS - Swivel 45° Elbow ISO 12151-1 - SWE 45° SAE J516 - ORFS 45°</p> | <p>J9</p>  <p>Female ORFS - Swivel 90° Elbow - Short Drop ISO 12151-1 - SWES SAE J516 - ORFS 90°</p> |
| <p>J1</p>  <p>Female ORFS - Swivel 90° Elbow - Long Drop ISO 12151-1 - SWEL SAE J516 - ORFS 90° L</p> | <p>J5</p>  <p>Female ORFS - Swivel 90° Elbow - Medium Drop ISO 12151-1 - SWEM - ORFS 90° M</p> | <p>JM</p>  <p>ORFS Male ISO 12151-1-S - SAE J516</p> | <p>JD</p>  <p>Male ORFS Bulkhead with Locknut Straight (with O-ring) ISO 12151-1 - SAE J516</p> |

Technical handbook

JIS

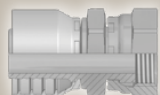
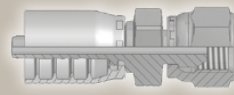
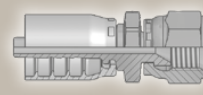
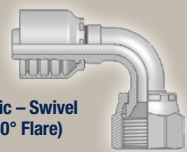
| | | | |
|---------------------------------------------------------------------------------------------------------------------------------------------------------------------------------------------------------|--------------------------------------------------------------------------------------------------------------------------------------------------------------------------------------------------------|----------------------------------------------------------------------------------------------------------------------------------------------------------------------------------|--------------------------------------------------------------------------------------------------------------------------------------------------------------------------------|
| <p>FU</p>  <p>Female BSP Parallel Pipe Swivel - Straight (30° Flare) ISO 228-1 - JIS B8363 - GUI</p> | <p>GU</p>  <p>Female BSP Parallel Pipe Swivel - Straight (60° Cone) ISO 228-1 - JIS B8363 - GUO</p> | <p>MU</p>  <p>Female Metric - Swivel Straight (30° Flare) JIS B8363 - MU</p> | <p>MZ</p>  <p>Female Metric - Swivel 90° Elbow (30° Flare) JIS B8363</p> |
|---------------------------------------------------------------------------------------------------------------------------------------------------------------------------------------------------------|--------------------------------------------------------------------------------------------------------------------------------------------------------------------------------------------------------|----------------------------------------------------------------------------------------------------------------------------------------------------------------------------------|--------------------------------------------------------------------------------------------------------------------------------------------------------------------------------|

High Pressure Cleaning

| | | |
|---------------------------------------------------------------------------------------------------------------------------------------------|----------------------------------------------------------------------------------------------------------------------------------------------------------------------------------|--------------------------------------------------------------------------------------------------------------------------------------------------------------------------------|
| <p>CW</p>  <p>Power Cleaner Connection</p> | <p>NW</p>  <p>Female Kärcher Metric Cleaning Hose Fitting Swivel - Straight</p> | <p>PW</p>  <p>Male Kärcher Metric Cleaning Hose Fitting Rigid - Straight</p> |
|---------------------------------------------------------------------------------------------------------------------------------------------|----------------------------------------------------------------------------------------------------------------------------------------------------------------------------------|--------------------------------------------------------------------------------------------------------------------------------------------------------------------------------|

Others

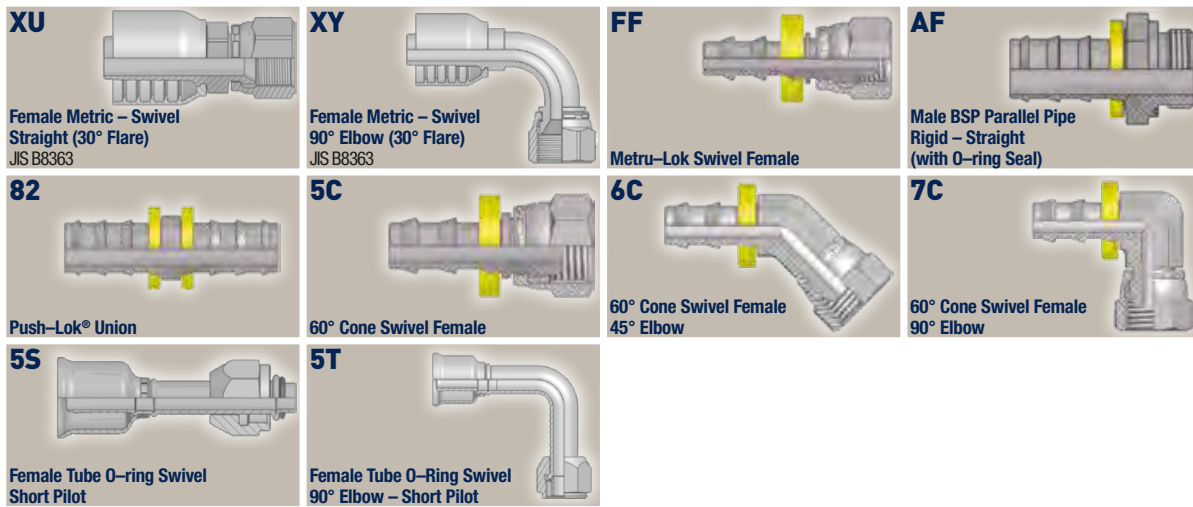

UPTC

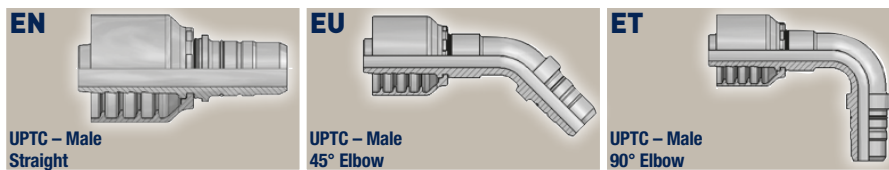

Hose fittings pressure ratings

* static working pressure
** dynamic working pressure

| Fitting end connection | Description | Inch fittings (size) | | | | | | | | | | | | | | |
|--------------------------------------------|----------------------------------------|----------------------------------------------------|------|------|------|------|------|------|------|------|------|------|-------|--------|-----|-----|
| | | Maximum working pressure (MPa) – design factor 4:1 | | | | | | | | | | | | | | |
| | | -4 | -5 | -6 | -8 | -10 | -12 | -16 | -20 | -24 | -32 | -40 | -48 | -56 | -64 | -80 |
| 92, B1, B2 | BSP swivel female | 63.0 | | 55.0 | 43.0 | 42.0 | 42.0 | 42.0 | 35.0 | 30.0 | 25.0 | | | | | |
| B5 | BSP swivel female flat seat | 63.0 | | 55.0 | 43.0 | 37.5 | 35.0 | 28.0 | 25.0 | 21.0 | 21.0 | | | | | |
| B4 | BSP swivel female (compact brazed) | 35.0 | 35.0 | 35.0 | 35.0 | 35.0 | 35.0 | 28.0 | 25.0 | 21.0 | 21.0 | | | | | |
| EA, EB, EC | BSP swivel female with O-ring | 45.0 | | 45.0 | 42.0 | 42.0 | 42.0 | 42.0 | 35.0 | 30.0 | 25.0 | | | | | |
| 91, D9 | BSP male | 63.0 | | 55.0 | 43.0 | | 35.0 | 28.0 | 25.0 | 21.0 | 21.0 | | | | | |
| 01 | NPTF male | 83.0 | | 69.0 | 69.0 | | 52.0 | 45.0 | 35.0 | 21.0 | 17.5 | 35.0 | 35.0* | 21.0** | | |
| 02 | NPTF female | 48.0 | | 41.0 | 35.0 | | 28.0 | 21.0 | 17.5 | 14.0 | 14.0 | | | | | |
| 03, 33 | SAE (JIC) 37° male | 41.0 | 41.0 | 35.0 | 35.0 | 35.0 | 35.0 | 28.0 | 21.0 | 17.5 | 17.5 | | | | | |
| 04 | SAE 45° male | 41.0 | 41.0 | 35.0 | 35.0 | 35.0 | 35.0 | 28.0 | 21.0 | 17.5 | 17.5 | | | | | |
| 05 | SAE male with O-ring | 41.0 | 41.0 | 35.0 | 35.0 | 35.0 | 35.0 | 28.0 | 21.0 | 17.5 | 17.5 | | | | | |
| 06/68,37/3V, 39/3W, 41/3Y | SAE (JIC) 37° swivel female | 41.0 | 41.0 | 35.0 | 35.0 | 35.0 | 35.0 | 28.0 | 21.0 | 17.5 | 17.5 | | | | | |
| 07 | Female NPSM-pipe swivel | 48.0 | | 41.0 | 35.0 | | 28.0 | 21.0 | | | | | | | | |
| 08, 77, 79 | Female SAE 45° swivel | 21.0 | 21.0 | 21.0 | 21.0 | 19.0 | 15.5 | 14.0 | 11.0 | 9.0 | 8.0 | | | | | |
| 1L | Male NPTF pipe swivel 90° Elbow | 21.0 | 21.0 | 21.0 | 21.0 | 19.0 | 15.5 | 14.0 | 11.0 | 9.0 | 8.0 | | | | | |
| S2 | Female NPTF pipe swivel | 21.0 | 21.0 | 21.0 | 21.0 | 19.0 | 15.5 | 14.0 | 11.0 | 9.0 | 8.0 | | | | | |
| 0G, 0L | Male SAE O-ring | 21.0 | 21.0 | 21.0 | 21.0 | 19.0 | 15.5 | 14.0 | 11.0 | 9.0 | 8.0 | | | | | |
| 28, 67, 69 | SAE Male inverted 45° swivel | 19.0 | 17.5 | 15.5 | 14.0 | | | | | | | | | | | |
| 15, 16, 17, 18, 19, 26, 27, 89, X5, X7, X9 | ISO 6162-1 Flange (21.0 MPa/ 3000 psi) | | | | 35.0 | 35.0 | 35.0 | 35.0 | 28.0 | 28.0 | 21.0 | 17.5 | 16.0 | 3.5 | 3.5 | 3.5 |
| 4A, 4N, 4F | ISO 6162-1 Flange (35.0 MPa/ 5000 psi) | | | | | | | | 35.0 | 35.0 | 35.0 | | | | | |
| 6E, 6F, 6G, 6N, XA, XF, XG, XN, X5, X7, X9 | ISO 6162-2 Flange (42.0 MPa/ 6000 psi) | | | | 42.0 | | 42.0 | 42.0 | 42.0 | 42.0 | 42.0 | | | | | |
| 6A | ISO 6162-2 Flange (42.0 MPa/ 6000 psi) | | | | 42.0 | | 42.0 | 42.0 | 42.0 | 42.0 | 42.0 | 42.0 | 42.0 | | | |
| 8A, 8F, 8N | SAE Flange 8000 psi | | | | | | 56.0 | 56.0 | 56.0 | | | | | | | |
| S0 | Male SteckO Rigid | 45.0 | | 40.0 | 36.2 | | 28.0 | 28.0 | 21.0 | 21.0 | 17.0 | | | | | |

| Fitting end connection | Description | Inch fittings (size) | | | | | | | | | |
|--------------------------------|-------------------------------------------|----------------------------------------------------|------|------|------|------|------|------|------|------|-----|
| | | Maximum working pressure (MPa) – design factor 4:1 | | | | | | | | | |
| | | -4 | -5 | -6 | -8 | -10 | -12 | -16 | -20 | -24 | -32 |
| JM, JC, JS, J1, J5, J7, J9, JD | ORFS male / female | 63.5 | | 63.5 | 63.5 | 41.0 | 41.0 | 41.0 | 28.0 | 28.0 | |
| GU | JIS / BSP swivel female 60° cone | 35.0 | 35.0 | 35.0 | 35.0 | | 28.0 | 21.0 | 17.5 | | |
| FU | Female JIS / BSP 30° parallel pipe swivel | 35.0 | 35.0 | 35.0 | 35.0 | 28.0 | 28.0 | 21.0 | 17.5 | | |
| MZ | Metric swivel female 90° Elbow | 35.0 | 35.0 | 35.0 | 35.0 | 28.0 | 28.0 | 21.0 | 17.5 | | |
| UT | JIS / BSP male 60° cone | 35.0 | | 35.0 | 35.0 | | 28.0 | 21.0 | 17.5 | | |
| V1 | Banjo soft seal with UNF bolt | 25.0 | 25.0 | | 21.5 | 21.5 | 20.0 | | | | |
| XU, XY | Female Metric swivel 30° Flare | 35.0 | 35.0 | 35.0 | 35.0 | 28.0 | 28.0 | 21.0 | 17.5 | | |

| Fitting end connection | Description | Metric tube (mm) • Light series – L | | | | | | | | | |
|------------------------|----------------------------------------|----------------------------------------------------|------|------|------|------|------|------|------|------|------|
| | | Maximum working pressure (MPa) – design factor 4:1 | | | | | | | | | |
| | | 6 | 8 | 10 | 12 | 15 | 18 | 22 | 28 | 35 | 42 |
| CA, CE, CF | ISO 12151-2 swivel female with O-ring | 31.5 | 42.5 | 40.0 | 35.0 | 31.5 | 31.5 | 28.0 | 21.0 | 16.0 | 16.0 |
| D0, DF, DG, DK | ISO 12151-2 male stud | 25.0 | 42.5 | 40.0 | 35.0 | 31.0 | 28.0 | 28.0 | 21.0 | 16.0 | 16.0 |
| DX | Metric swivel female with O-ring | 31.5 | 42.5 | 40.0 | 35.0 | 31.5 | 31.5 | 28.0 | 21.0 | 16.0 | 16.0 |
| CW, NW | High pressure cleaning hose connection | | | | | 40.0 | | | | | |
| PW | High pressure cleaning hose connection | | | 22.5 | | | | | | | |
| EN, ET, EU | Universal push-in connector | | 40.0 | 35.0 | 35.0 | 29.5 | 28.0 | 21.5 | | | |

| Fitting end connection | Description | Metric tube (mm) • Metric | | | | | | | | | | |
|------------------------|------------------------------------|----------------------------------------------------|------|------|------|------|------|------|------|------|------|------|
| | | Maximum working pressure (MPa) – design factor 4:1 | | | | | | | | | | |
| | | 6 | 8 | 10 | 12 | 14 | 16 | 18 | 20 | 22 | 25 | 27 |
| 49 | Metric Banjo - straight (DIN 7642) | 20.0 | 20.0 | 20.0 | 20.0 | 20.0 | 20.0 | 20.0 | 20.0 | 20.0 | 20.0 | 20.0 |
| V2 | Banjo soft seal with metric bolt | | | | 25.0 | 25.0 | | 21.5 | | 21.5 | | 20.0 |

| Fitting end connection | Description | Metric tube (mm) • Heavy series – S | | | | | | | | | |
|------------------------|---------------------------------------|----------------------------------------------------|------|------|------|------|------|------|------|------|------|
| | | Maximum working pressure (MPa) – design factor 4:1 | | | | | | | | | |
| | | 6 | 8 | 10 | 12 | 14 | 16 | 20 | 25 | 30 | 38 |
| C9, 0C, 1C | ISO 12151-2 swivel female with O-ring | 63.0 | 63.0 | 63.0 | 63.0 | 63.0 | 42.0 | 42.0 | 42.0 | 42.0 | 42.0 |
| D2 | Male stud | 63.0 | 63.0 | 63.0 | 63.0 | 63.0 | 42.0 | 42.0 | 42.0 | 42.0 | 42.0 |

Hose fittings nomenclature

| End configuration | Description | Standards | Common terms |
|-------------------|-------------------------------------------------------------------|-------------------------|----------------------|
| 01 | Male NPTF Pipe – Rigid – Straight | SAE J476A / J516 | AGN |
| 02 | Female NPTF Pipe – Rigid – Straight | SAE J476A / J516 | |
| 03 | Male JIC 37° – Rigid – Straight | ISO12151-5-S | AGJ |
| 04 | Male SAE 45° – Rigid – Straight | SAE J516 | |
| 05 | Male SAE Straight Thread with O-ring – Rigid – Straight | ISO 11926, SAE J516 | |
| 06 | Female JIC 37° Swivel – Straight | ISO12151-5-SWS | DKJ |
| 06/68 | Female – JIC 37° / SAE 45° Dual Flare – Swivel – Straight | ISO12151-5-SWS | DKJ |
| 07 | Female NPSM Pipe Swivel | | |
| 08 | Female SAE 45° – Swivel – Straight | SAE J516 | |
| 0C | Female Metric 24° – Heavy Series with O-ring – Swivel – 45° Elbow | ISO 12151-2 – SWE 45°-S | DKOS 45° |
| 0G | Male O-ring Straight | | |
| 0L | Male O-ring 90° Elbow | | |
| 11 | „Ferrul-Fix“ | | |
| 12 | Female SAE Flareless Swivel – Straight (24° Cone) | | |
| 13 | Male NPTF Pipe Swivel | SAE J476A / J516 | |
| 15 | ISO 6162-1 – Flange Head – Straight | ISO 12151-3-S-L | SFL / 3000 psi |
| 15/4A | ISO 6162-1 – Flange Head – Straight / SAE Flange Head (5000 psi) | ISO 12151-3-S-L | SFL |
| 16 | ISO 6162-1 – Flange Head – 22.5° Elbow | ISO 12151-3-E22ML | SFL 22.5° / 3000 psi |
| 17 | ISO 6162-1 – Flange Head – 45° Elbow | ISO 12151-3 – E45 – L | SFL 45° / 3000 psi |
| 17/4F | ISO 6162-1 – Flange – 45° Elbow – 45° Elbow (5000 psi) | ISO 12151-3 – E45S – L | SFL 45° |
| 18 | ISO 6162-1 – Flange – 67.5° Elbow | | SFL 67.5° |
| 19 | ISO 6162-1 – Flange Head – 90° Elbow | ISO 12151-3 – E– L | SFL 90° / 3000 psi |
| 19/4N | ISO 6162-1 – Flange Head – 90° Elbow (5000 psi) | ISO 12151-3-E-L | SFL 90° |
| 1C | Female Metric 24° – Heavy Series with O-ring – Swivel – 90° Elbow | ISO 12151-2-SWE-S | DKOS 90° |
| 1D | Metric Standpipe – Light Series – Rigid – Straight | ISO 8434-1 | BEL |
| 1L | Male NPTF Pipe Swivel – 90° Elbow | | |
| 26 | ISO 6162-1 Flange – 30° Elbow | | SFL 30° |
| 27 | ISO 6162-1 Flange – 60° Elbow | | SFL 60° |
| 28 | SAE Male Inverted 45° Elbow | | |
| 33 | Male JIC 37° – Rigid – 45° Elbow | ISO 12151-5 | AGJ 45° |
| 34 | Inch Standpipe (Brass) | | |
| 37 | Female JIC 37° – Swivel – 45° Elbow | ISO 12151-5-SWE 45° | DKJ 45° |
| 37/3V | Female JIC 37° /SAE 45° – Dual Flare – Swivel Female 45° Elbow | ISO 12151-5-SWE 45° | DKJ 45° |
| 39 | Female JIC 37° – Swivel – 90° Elbow | ISO 12151-5-SWES | DKJ 90° |
| 39/3W | Female JIC 37° / SAE 45° – Dual Flare – Swivel Female 90° Elbow | ISO 12151-5-SWES | DKJ 90° |
| 3D | Metric Standpipe – Heavy Series – Rigid – Straight | ISO 8434-1 | BES |
| 3V | Female JIC 37°/SAE – 45° Swivel – 45° Elbow | | DKJ 45° |
| 3W | Female JIC 37°/SAE – 45° Swivel – 90° Elbow | | DKJ 90° |
| 3Y | Female JIC 37°/SAE – 45° Swivel – 90° Elbow (Long) | | DKJ 90° |
| 41 | Female JIC 37° Swivel – 90° Elbow (Long) | | DKJ 90° |
| 41/3Y | Female JIC 37° / 45° Swivel Female 90° Elbow (Long) | ISO 12151-5-SWEL | DKJ 90°L |
| 45 | Male Tube O-ring Swivel – Long Pilot | | |

Technical handbook

| End configuration | Description | Standards | Common terms |
|-------------------|----------------------------------------------------------|-----------------------------------|--------------------|
| 49 | Metric Banjo – Straight | DIN 7642 | |
| 4A | ISO 6162-1 – Flange – Straight (5000 psi) | | |
| 4F | ISO 6162-1 – Flange – 45° Elbow (5000 psi) | | |
| 4N | ISO 6162-1 – Flange – 90° Elbow (5000 psi) | | |
| 59 | Female Tube O-ring Swivel – Long Pilot | | |
| 59PT | Male Tube O-ring Swivel – Long Pilot | With Charge Port at 180° for 134a | |
| 5C | 60° Cone Swivel Female | | |
| 5D | Metric Standpipe – Light Series – Rigid – 90° Elbow | ISO 8434-1 | BEL 90° |
| 5G | Male Tube O-ring Rigid Port (3 step) Straight | | |
| 5GPR | Female Tube O-ring Rigid Port (3 step) Straight | With Charge Port for R12 | |
| 5H | Female Tube O-ring Swivel – 45° Elbow – Short Pilot | | |
| 5K | Male Tube O-ring Swivel – 90° Elbow – Short Pilot | | |
| 5LPR | Female Tube O-ring Swivel – 90° Elbow – Long Pilot | | |
| 5LPT | Female Tube O-ring Swivel – 90° Elbow – Long Pilot | With Charge Port at 180° for 134a | |
| 5MPR | Male Tube O-ring Swivel – 90° Elbow – Long Pilot | With Charge Port at 180° for R12 | |
| 5MPV | Male Tube O-ring Swivel – 90° Elbow – Long Pilot | With Charge Port at 270° for 134a | |
| 5N | Female Tube O-ring Swivel – 45° Elbow – Long Pilot | | |
| 5P | Female Tube O-ring Swivel – 45° Elbow – Long Pilot | | |
| 5R | Male Tube O-ring Swivel – 45° Elbow – Short Pilot | | |
| 5S | Female Tube O-ring Swivel – Short Pilot | | |
| 5T | Female Tube O-ring Swivel – 90° Elbow – Short Pilot | | |
| 5V | Female Compressor – Swivel 45° Elbow | | |
| 5W | Female Compressor – Swivel 90° Elbow | | |
| 5Z | Female Compressor – Swivel 90° Elbow – Block Type | | |
| 67 | SAE Male Inverted Flare Swivel – 45° Elbow | | |
| 68 | Female JIC 37° / SAE 45° Swivel | | DKJ |
| 69 | SAE Male Inverted Flare Swivel – 90° Elbow | | |
| 6A | ISO 6162-2 – Flange – Straight | ISO 12151-3-S-S | SFS / 6000 psi |
| 6B | ISO 6162-2 – Flange – 22.5° Elbow | | SFS 22.5° |
| 6C | 60° Cone Swivel Female – 45° Elbow | | |
| 6E | ISO 6162-2 – Flange – 30° Elbow | | SFS 30° |
| 6F | ISO 6162-2 – Flange – 45° Elbow | ISO 12151-3 – E45-S | SFS 45° / 6000 psi |
| 6G | ISO 6162-2 – Flange – 60° Elbow | | SFS 60° |
| 6N | ISO 6162-2 – Flange – 90° Elbow | ISO 12151-3 – E-S | SFS 90° / 6000 psi |
| 77 | Female SAE 45° Swivel – 45° Elbow | | |
| 79 | Female SAE 45° Swivel – 90° Elbow | | |
| 7C | 60° Cone Swivel Female – 90° Elbow | | |
| 7D | Male Standpipe Metric S – Rigid – 90° Elbow | | BES 90° |
| 82 | Push-Lok® Union | | |
| 89 | ISO 6162-1 – Flange – 90° Elbow (Long) – Standard Series | | |
| 8A | Flange – Straight – 8000 psi | | |
| 8F | Flange – 45° Elbow – 8000 psi | | |
| 8N | Flange – 90° Elbow – 8000 psi | | |
| 91 | Male BSP Taper Pipe – Rigid – Straight | BS5200 | AGR-K |

Technical handbook

| End configuration | Description | Standards | Common terms |
|-------------------|----------------------------------------------------------------------|---------------------------------|------------------|
| 92 | Female BSP Parallel Pipe – Swivel – Straight (60° Cone) | BS5200-A | DKR |
| 93 | Female JIC 37° – Swivel – 90° Elbow (Block Type) | | |
| 9B | Metric – Swivel Female 45° Elbow – Light Series | | |
| 9C | Light Series Metric Swivel Female 90° Elbow | | |
| AF | Male BSP Parallel Pipe – Rigid – Straight (with O-ring Seal) | | |
| B1 | Female BSP Parallel Pipe – Swivel – 45° Elbow (60° Cone) | BS 5200-D | DKR 45° |
| B2 | Female BSP Parallel Pipe – Swivel – 90° Elbow (60° Cone) | BS 5200-B | DKR 90° |
| B4 | Female BSP Parallel Pipe – Swivel – 90° Elbow Block Type (60° Cone) | BS 5200-E | DKR 90° |
| B5 | Female BSP Parallel Pipe – Swivel – Straight (Flat Seat) | | |
| C0 | Female Metric – Very Light Series LL – Swivel – Straight (Ball Nose) | | DKM |
| C3 | Female Metric – Light Series – Swivel – Straight (Ball Nose) | | DKL |
| C4 | Female Metric – Light Series – Swivel – 45° Elbow (Ball Nose) | | DKL 45° |
| C5 | Female Metric – Light Series – Swivel – 90° Elbow (Ball Nose) | | DKL 90° |
| C6 | Female Metric – Heavy Series – Swivel – Straight (Ball Nose) | | DKS |
| C7 | Female Metric Swivel – 45° Elbow “Heavy” Series | | DKS 45° |
| C8 | Female Metric Swivel – 90° Elbow “Heavy” Series | | DKS 90° |
| C9 | Female Metric 24° – Heavy Series with O-ring – Swivel – Straight | ISO 12151-2-SWS-S | DKOS |
| CA | Female Metric 24° – Light Series with O-ring – Swivel – Straight | ISO 12151-2-SWS-L | DKOL |
| CE | Female Metric 24° – Light Series with O-ring – Swivel – 45° Elbow | ISO 12151-2-SWE 45°-L | DKOL 45° |
| CF | Female Metric 24° – Light Series with O-ring – Swivel – 90° Elbow | ISO 12151-2-SWE-L | DKOL 90° |
| CW | Power Cleaner Connection | | |
| D0 | Male Metric 24° – Light Series – Rigid – Straight | ISO 12151-2-S-L | CEL |
| D2 | Male Metric 24° – Heavy Series – Rigid – Straight | ISO 12151-2-S-S | CES |
| D9 | Male BSP Parallel Pipe – Rigid – Straight (60° Cone) | BS5200 | AGR |
| DD | Metric Standpipe – Light Series – Rigid – 45° Elbow | | BEL 45° |
| DE | Double Banjo Union | | |
| DF | Male Metric L – Rigid – 45° Elbow (24° Cone) | | DIN 20078 Form D |
| DG | Male Metric L – Rigid – 90° Elbow (24° Cone) | | DIN 20078 Form D |
| DP | Metric Swivel Female Tee / Male Stud | | |
| DR | Metric Swivel Female Tee | | |
| DS | Metric Swivel Female Tee / Standpipe | | |
| DW | Female Metric Swivel „Light“ Series | | TGL |
| EA | BSP Swivel Female with O-ring (60° Cone) | BS 5200, ISO 12151-6 | DKOR |
| EB | BSP Swivel Female with O-ring – 45° Elbow (60° Cone) | BS 5200, ISO 12151-6 | DKOR 45° |
| EC | BSP Swivel Female with O-ring – 90° Elbow (60° Cone) | BS 5200, ISO 12151-6 | DKOR 90° |
| EN | UPTC – Male – Straight | | |
| ET | UPTC – Male – 90° Elbow | | |
| EU | UPTC – Male – 45° Elbow | | |
| FF | Metru-Lok Swivel Female | | |
| FU | Female BSP Parallel Pipe – Swivel – Straight (30° Flare) | ISO 228-1, JIS B8363 | GUI |
| GU | Female BSP Parallel Pipe – Swivel – Straight (60° Cone) | ISO 228-1, JIS B8363 | GUO |
| J1 | Female ORFS – Swivel – 90° Elbow – Long Drop | ISO 12151-1 – SWEL, SAE J 516 | ORFS 90° L |
| J5 | Female ORFS – Swivel – 90° Elbow – Medium Drop | ISO 12151-1 – SWEM | ORFS 90° M |
| J7 | Female ORFS – Swivel – 45° Elbow | ISO 12151-1 – SWE 45°, SAE J516 | ORFS 45° |

Technical handbook

| End configuration | Description | Standards | Common terms |
|-------------------|----------------------------------------------------------------------|--------------------------------------|--------------|
| J9 | Female ORFS – Swivel – 90° Elbow – Short Drop | ISO 12151-1 – SWES, SAE J516 | ORFS 90° |
| JC | Female ORFS – Swivel – Straight – Short | ISO 12151-1 – SWSA, SAE J516 | ORFS |
| JD | Male ORFS – Bulkhead with Locknut – Straight (with O-ring) | ISO 12151-1 – SAE J516 | |
| JM | ORFS Male | ISO 12151-1-S, SAE J516 | |
| JS | ORFS Swivel Female (Long) | ISO 12151-1-SWSB, SAE J516 | ORFS |
| L9 | Female JIC 37° – Swivel – 90° Elbow – Medium Drop | ISO 12151-5-SWEM | DKJ 90° M |
| MU | Female Metric – Swivel – Straight (30° Flare) | JIS B8363 | MU |
| MZ | Female Metric – Swivel – 90° Elbow (30° Flare) | JIS B8363 | |
| NM | Male BSP Parallel Pipe – L Series – Rigid – Straight – ED-Seal | ISO 1179 | |
| NW | Female Kärcher Metric Cleaning Hose Fitting – Swivel – Straight | | |
| PW | Male Kärcher Metric Cleaning Hose Fitting – Rigid – Straight | | |
| PY | Flange – 24° Male – French Gas – Straight | | |
| S2 | Female NPTF Pipe Swivel | | |
| S5 | Male Tube O-ring Swivel – Short Pilot | | |
| T1 | Male Refrigerant Tube Mender – Straight (with Nut and Ferrule) | | |
| UT | Male BSP Taper Pipe – Rigid – Straight (60° Cone) | JIS B 8363-R | |
| V1 | Ermeto standard Pressure Banjo – Straight (with UNF Bolt and O-ring) | | |
| VW | Push In Connector | (VW-Standard 39-V-16619) | |
| VW121 | BSP Swivel Female | (VW-Norm 39-V-16631) | |
| VW39D | Push In Connector | (VW-Standard 39D-1401) | |
| WKS | Rubber hand grip | | |
| X5 | Flange – Straight – Full flange system for ISO 6162-1 or ISO 6162-2 | | |
| X7 | Flange – 45° Elbow – Full flange system for ISO 6162-1 or ISO 6162-2 | | |
| X9 | Flange – 90° Elbow – Full flange system for ISO 6162-1 or ISO 6162-2 | | |
| XA | Caterpillar® Flange Head – Straight | | |
| XF | Caterpillar® Flange Head – 45° Elbow | | |
| XG | Caterpillar® Flange Head – 60° Elbow | | |
| XN | Caterpillar® Flange Head – 90° Elbow | | |
| XU | Female Metric – Swivel – Straight (30° Flare) | JIS B8363 | |
| XY | Female Metric – Swivel – 90° Elbow (30° Flare) | JIS B8363 | |
| YW | Male Standpipe – Rigid – Straight – A-Lok | Metric Size Tube O.D. with Vee Notch | |

Classification bodies

The mission of classification bodies is to contribute to the development and implementation of technical standards for the protection of life, property and the environment.

- | | |
|---------------------------------------------------------------------------------------------------------------------------------------------------------------------------------------------------------------------------------------------------------------------------------------------------------------------------------------------------------------------------------------------------------------------------------------------------------------------------------------------------------------------------------------------------------------------------------------------------------------------------------------------------------------------------------------------------------------------------------------------------------------------------------------------------------------------------------------------------------------------------------------------------------------------------------------------------------------------------------------------------------------------------------------------------------------------------------------------------------------------------------------------------------------------------------------------------------------------------------------------------------------------------------------------------------|-------------------------------------------------------------------------------------------------------------------------------------------------------------------------------------------------------------------------------------------------------------------------------------------------------------------------------------------------------------------------------------------------------------------------------------------------------------------------------------------------------------------------------------------------------------------------------------------------------------------------------------------------------------------------------------------------------------------------------------------------------------------------------------------------------------------------------------------------------------------------------------------------------------------------------------------------------------------------------------------------------------------------------------------------------------------------------------------------------------------------------------------------------------------------------------------------------------------------------------------------------------------------------------------------------------------|
| <p>(1) Det Norske Veritas - Germanischer Lloyd (DNV-GL) Norwegian service company for managing risk in ship classification, off-shore industry, etc... German independent organisation of technical experts approving products for the German mercantile marine and the energy sector – GLIS (oil and gas, wind energy, etc...)</p> <p>(2) Registro Italiano Navale (RINA) Italian company offering certification, verification, control, assistance in marine, energy & process, transport and industry.</p> <p>(3) Lloyd's Register (LR) English independent organisation providing certification around the world. Marine services, Rail services and Energy services are their main activities.</p> <p>(4) American Bureau of Shipping (ABS) US company providing rules for safety in the marine environment.</p> <p>(5) European Rail Standard (EN 45545) Railway application – Fire protection on railway vehicles. Requirements for fire behavior of materials and components (hose and hose assemblies).</p> <p>(6) US Department of Transportation (DOT) US organisation providing certifications to ensure a fast, safe, efficient, accessible and convenient transportation system in this country.</p> | <p>(7) US Coast Guard (USCG) Provides maritime safety, law enforcement, recreational boating safety, and environmental protection information for merchant mariners. The approved hoses are not accepted for all applications automatically. If the column contains “H”, the hose is accepted for hydraulic systems only and not for fuel and lube systems.</p> <p>(8) Mine Safety and Health Administration (MSHA) US organisation for safety in the mining industry</p> <p>(9) MarED MarED is the Group of Notified Bodies for the Implementation of the Marine Equipment Directive.</p> <p>(10) Bureau Veritas (BV) Bureau Veritas is today the most widely recognized certification body in the world, offering solutions in the key strategic fields of operations: Quality, Health & Safety, Environment and Social Responsibility.</p> <p>(11) Verteidigungs-Gerätenorm (VG) German Organisation providing approvals for military equipment.</p> <p>(12) TEST JOAICW TEST (Jednostka Opiniująca, Atestująca i Certyfikująca Wyroby TEST – Product Assessment, Approval and Certification Body TEST) is a private certification body authorised to test and certify equipment and components for use in Polish underground mines.</p> |
|---------------------------------------------------------------------------------------------------------------------------------------------------------------------------------------------------------------------------------------------------------------------------------------------------------------------------------------------------------------------------------------------------------------------------------------------------------------------------------------------------------------------------------------------------------------------------------------------------------------------------------------------------------------------------------------------------------------------------------------------------------------------------------------------------------------------------------------------------------------------------------------------------------------------------------------------------------------------------------------------------------------------------------------------------------------------------------------------------------------------------------------------------------------------------------------------------------------------------------------------------------------------------------------------------------|-------------------------------------------------------------------------------------------------------------------------------------------------------------------------------------------------------------------------------------------------------------------------------------------------------------------------------------------------------------------------------------------------------------------------------------------------------------------------------------------------------------------------------------------------------------------------------------------------------------------------------------------------------------------------------------------------------------------------------------------------------------------------------------------------------------------------------------------------------------------------------------------------------------------------------------------------------------------------------------------------------------------------------------------------------------------------------------------------------------------------------------------------------------------------------------------------------------------------------------------------------------------------------------------------------------------|

| | |
|------------|---------------------------------------------------|
| EN | European standard |
| ISO | International Organisation for Standardization |
| SAE | Society of Automotive Engineers (US organisation) |

Description (1)-(12) see Ab-16

Approvals for Parker hydraulic hoses

| Hose | Construction | Standard | DIN/GL (1) | RINA (2) | LR (3) | ABS (4) | Reg (EM/45/45) (5) | DOT (6) | USCG (7) | MSHA (8) | MarED (9) | BV (10) | VG (11) | TEST (12) |
|---------|----------------|---------------------------|------------|----------|--------|---------|--------------------|---------|----------|----------|-----------|---------|---------|-----------|
| 801Plus | 1 braid, fibre | | | | | | | | | | | | | |
| 830M | 1 braid, fibre | | | | | | | | | | | | | |
| 837BM | 1 braid, fibre | | | | | | | | | | | | | |
| 837PU | 1 braid, fibre | | | | | | | | | | | | | |
| 801RH | 1 braid, fibre | | | | | | X | | | | | | | |
| 804 | 1 braid, fibre | | | | | | | | | | | | | |
| 821FR | 1 braid, fibre | | | | | | | | | X | | | | |
| 836 | 1 braid, fibre | | | | | | | | | X | | | | |
| 846 | 1 braid, fibre | | | | | | | | | X | | | | |
| 838M | 1 braid, fibre | | | | | | | | | | | | | |
| 681 | 1 braid, fibre | EN 854-2TE | | | | | | | | | | | | |
| 611HT | 1 braid, fibre | EN 854-R6 | | | | | | | | X | | | | |
| 681DB | 1 braid, fibre | EN 854-2TE | | | | | X | | | | | | | |
| 201 | 1 braid, wire | SAE 100R5 - SAE J1402 All | | | | | | X | | | | | | |
| 206 | 1 braid, wire | SAE 100R5 - SAE J1402 All | | | | | | X | | | | | | |
| 213 | 1 braid, wire | SAE J1402 AI | | | | | | X | | | | | | |
| 293 | 1 braid, wire | SAE J1402 AI | | | | | | X | | | | | | |
| 221FR | 1 braid, wire | SAE J1527 R3 | X | | | X | | | H | X | | | | |
| 285 | 1 braid, fibre | SAE J3062 Type C | | | | | | | | | | | | |
| 244 | 1 braid, wire | SAE J2064 B Class I | | | | | | | | | | | | |



Description (1)-(12) see Ab-16

Approvals for Parker hydraulic hoses

Medium pressure

| Hose | Construction | Standard | DIN/GL (1) | RIMA (2) | LR (3) | ABS (4) | Rail (EN 45545) (5) | DOT (6) | USCG (7) | MSHA (8) | MaxED (9) | BV (10) | VG (11) | TEST (12) |
|------------|-------------------------------|--------------------------------------------------|------------|----------|--------|---------|---------------------|---------|----------|----------|-----------|---------|---------|-----------|
| 187 | 2 braids, wire | Exceeds ISO 18752-AS | | | | | | | | X | | | | |
| 187TC/ST | 2 braids, wire | Exceeds ISO 18752-AS | | | | | | | | | | | | |
| 387 | 1/2 braids, wire ¹ | Exceeds ISO 18752-AC - ISO 18752-BC ² | X | | X | X | | | | X | | | | |
| 387TC/ST | 1/2 braids, wire ¹ | Exceeds ISO 18752-AC - ISO 18752-CC ² | | | | | | | | | | | | |
| 487 | 1/2 braids, wire ¹ | Exceeds ISO 18752-AC - ISO 18752-BC ² | X | | X | X | | | | X | | | | |
| 487TC/ST | 1/2 braids, wire ¹ | Exceeds ISO 18752-AC - ISO 18752-CC ² | | | | | | | | | | | | |
| BCH1 | 1 braid, wire | EN 857 1SC - ISO 11237 | | | | | | | | | | | | |
| BCH2 | 2 braids, wire | EN 857 2SC - ISO 11237 | | | | | | | | | | | | |
| 421SN | 1 braid, wire | EN 853-1SN - ISO 1436-1SN/R1AT - SAE 100R1AT | X | X | X | | | | | | X | X | X | |
| 301SN | 2 braids, wire | EN 853-2SN - ISO 1436-2SN/R2AT - SAE 100R2AT | X | X | X | | | | | | X | X | X | |
| 441 | 1/2 braids, wire ¹ | ISO 11237-R16 - SAE 100R16 | X | X | X | X | | | | | X | X | X | |
| 492 | 1 braid, wire | Exceeds EN 857-1SC - ISO 11237-1SC | X | X | X | X | | | | | X | X | X | |
| 462 | 2 braids, wire | Exceeds EN 857-2SC - ISO 11237-2SC | X | X | X | X | | | | | X | X | X | |
| 421TC | 1 braid, wire | EN 853 1SN - ISO 1436 Type 1 - SAE 100R1AT | | | | | | | | | | | | |
| 462TC | 2 braids, wire | Exceeds EN 857-2SC - ISO 11237-2SC | X | | | X | | | | X | | | | |
| 471TC | 2 braids, wire | EN 857-2SC - ISO 11237-2SC | | | | | | | | X | | | | |
| 492TC | 1 braid, wire | EN 857-1SC - ISO 11237-1SC | X | | | X | | | | X | | | | |
| 492ST | 1 braid, wire | EN 857-1SC - ISO 11237-1SC | X | | | X | | | | | | | | |
| 462ST | 2 braids, wire | EN 857-2SC - ISO 11237-2SC | X | | | X | | | | | | | | |
| 426 | 1 braid, wire | SAE 100R1AT | | | | X | | | X | X | | | | |
| 436 | 2 braids, wire | SAE 100R16 | | | | X | | | X | X | | | | |
| 461LT | 2 braids, wire | Exceeds EN 857-2SC - ISO 11237-2SC | | | | | | | | | | | | |
| HT2 | 2 braids, wire | Parker specification | | | | | | | | | | | | |
| 304 | 2 braids, wire | SAE 100R2AT | | | | | | | | | | | | |
| 441RH | 1/2 braids, wire ¹ | ISO 11237-R16 - SAE 100R16 | | | | | X | | | | | | | |
| 421RH | 1 braid, wire | EN 853-1SN - ISO 1436-1SN/R1AT - SAE 100R1AT | | | | | X | | | | | | | |
| 477RH | 2 braids, wire | | | | | | X | | | | | | | |
| 493 | 1 braid, wire | | | | | | | | | | | | | |
| 463 | 2 braids, wire | | | | | | | | | | | | | |
| 412 | 1 braid, wire | | | | | | | | | | | | | |
| 412ST | 1 braid, wire | | | | | | | | | | | | | |
| 421WC | 1 braid, wire | ISO S1436-1SN/R1AT - SAE 100R1AT | | | | | | | | | | | | |
| 477 | 2 braids, wire | | | | | | | | | | | | | |
| 477TC | 2 braids, wire | | | | | | | | | X | | | | |
| 477ST | 2 braids, wire | | | | | | | | | | | | | |
| 692 | 1/2 braids, wire ¹ | Exceeds SAE 100R17 | | | | | | | | | | | | |
| 692TWIN | 1/2 braids, wire ¹ | Exceeds SAE 100R17 | | | | | | | | | | | | |
| 692TC | 1/2 braids, wire ¹ | Exceeds SAE 100R17 | | | | | | | | X | | | | |
| 811 | 1 braid, 1 steelspiral | SAE 100R4 | X | | | X | | | | | | | | |
| 811S | 1 braid, 1 steelspiral | Exceeds SAE 100R4 | X | | | X | | | | | | | | |
| 881 | 1 braid, 1 steelspiral | SAE 100R4 | | | | | | | H | | | | | |
| 462PU | 2 braids, wire | Exceeds EN 857 2SC - ISO 11237 Typ 2SC | | | | | | | | | | | | |
| 462PU Twin | 2 braids, wire | Exceeds EN 857 2SC - ISO 11237 Typ 2SC | | | | | | | | | | | | |
| 692PU | 1/2 braids, wire ¹ | | | | | | | | | | | | | |
| 692PU Twin | 1/2 braids, wire ¹ | | | | | | | | | | | | | |

1: The hose construction depends on the hose ID (size). 2: The standard depends on the hose ID (size). For details, please refer to the respective hose page in this catalogue.



Description (1)-(12) see Ab-16

Approvals for Parker hydraulic hoses

| Hose | Construction | Standard | DIN-GL (1) | RIMA (2) | LR (3) | ABS (4) | Rail (EN 455-45) (5) | DOT (6) | USCG (7) | MSHA (8) | MarED (9) | BV (10) | VG (11) | TEST (12) |
|---------------------------|-------------------------------|-----------------------------------------------------|--------------------------------------------------|----------|--------|---------|----------------------|---------|----------|----------|-----------|---------|---------|-----------|
| GlobalCore | 722 | 4 spiral, wire | Exceeds ISO 18752-BC | | | | | | | | | | | |
| | 722TC | 4 spiral, wire | Exceeds ISO 18752-CC | X | X | X | | | X | X | | | | |
| | 722ST | 4 spiral, wire | Exceeds ISO 18752-CC | X | X | X | | | X | X | | | | |
| GlobalCore Compact Spiral | 787 | 4/6 spiral, wire ¹ | Exceeds ISO 18752-BC | | | | | | | | | | | |
| | 787TC | 4/6 spiral, wire ¹ | Exceeds ISO 18752-DC | X | X | X | | | X | X | | | | |
| | 787ST | 4/6 spiral, wire ¹ | Exceeds ISO 18752-DC | X | X | X | | | X | X | | | | |
| | 797 | 4/6 spiral, wire ¹ | Exceeds ISO 18752-BC | | | | | | | | | | | |
| | 797TC | 4/6 spiral, wire ¹ | Exceeds ISO 18752-DC - ISO 18752-CC ² | X | X | X | | | X | X | | | | |
| 797ST | 4/6 spiral, wire ¹ | Exceeds ISO 18752-DC - ISO 18752-CC ² | X | X | X | | | X | X | | | | | |
| 372 | 3 braids, wire | | X | | X | | | | | | X | | | |
| 371LT | 3 braids, wire | | | | | | | | | | | | | |
| 372TC | 3 braids, wire | | X | | | | | | | X | | | | |
| 372RH | 3 braids, wire | | | | | | X | | | | | | | |
| SX35 | 4 spiral, wire | ISO 3862 Typ R13 | | | | | | | | | | | | |
| SX42 | 4/6 spiral, wire ¹ | ISO 3862 Typ R15 | | | | | | | | | | | | |
| 701 | 4 spiral, wire | Exceeds EN 856-4SP - ISO 3862-4SP | X | | | | | | | | | | | X |
| 731 | 4 spiral, wire | Exceeds EN 856-4SH - ISO 3862-4SH | | | | | | | | | | | | |
| SX35LT | 4 spiral, wire | | | | | | | | | | | | | |
| SX42LT | 4/6 spiral, wire ¹ | | | | | | | | | | | | | |
| 774 | 4 spiral, wire | | | | | | | | | | | | | |
| F42 | 4/6 spiral, wire ¹ | ISO 3862-R15 - SAE 100R15 | | | | | | | | | | | | |
| SX35TC | 4 spiral, wire | ISO 3862 Typ R13 | | | | | | | | X | | | | |
| SX42TC | 4/6 spiral, wire ¹ | ISO 3862 Typ R15 | | | | | | | | X | | | | |
| 701TC | 4 spiral, wire | EN 856-4SP - ISO 3862-4SP | | | | | | | | X | | | | |
| 731TC | 4 spiral, wire | ISO 3862-4SH - EN 856-4SH | | | | | | | | X | | | | |
| 797RH | 4/6 spiral, wire ¹ | Exceeds SAE 100R15 - ISO 3862-R15 - ISO 18752-DC/CC | | | | | X | | | | | | | |
| H31 | 4 spiral, wire | Exceeds EN 856-4SP - ISO 3862-4SP | X | X | X | X | | | | | X | X | | |
| H29 | 4 spiral, wire | Exceeds EN 856-4SH - ISO 3862-4SH | X | X | X | X | | | | | X | X | | |
| R35 | 4/6 spiral, wire ¹ | EN 856-R13 - ISO 3862-R13 - SAE 100R13 | X | X | X | X | | | | | X | X | | |
| R42 | 4/6 spiral, wire ¹ | ISO 3862-R15 - SAE 100R15 | X | X | X | X | | | | | X | X | | |
| H31TC | 4 spiral, wire | Exceeds EN 856-4SP - ISO 3862-4SP | X | | | | | | | X | X | | | X |
| H29TC | 4 spiral, wire | Exceeds EN 856-4SH - ISO 3862-4SH | X | | | | | | | X | X | | | X |
| R35TC | 4/6 spiral, wire ¹ | EN 856-R13 - ISO 3862-R13 - SAE 100R13 | X | | | | | | | X | X | | | X |
| RD35TC | 6 spiral, wire | Exceeds ISO 3862 Typ R13 | | | | | | | | X | X | | | |
| RS35TC | 6 spiral, wire | ISO 6907-D | X | | | | | | | X | X | | | X |
| R42TC | 4/6 spiral, wire ¹ | ISO 3862-R15 - SAE 100R15 | X | | | | | | | X | X | | | |
| R50TC | 4/6 spiral, wire ¹ | Exceeds ISO 3862-R15 | | | | | | | | X | X | | | |
| R56TC | 4 spiral, wire | Exceeds ISO 3862-R15 | | | | | | | | X | X | | | |
| H315T | 4 spiral, wire | Exceeds EN 856-4SP - ISO 3862-4SP | X | | | | | | | X | X | | | |
| H295T | 4 spiral, wire | Exceeds EN 856-4SH - ISO 3862-4SH | X | | | | | | | X | X | | | |
| R425T | 4/6 spiral, wire ¹ | ISO 3862-R15 - SAE 100R15 | X | | | | | | | X | X | | | |
| BPK | 4/6 spiral, wire ¹ | | | | | | | | | | | | | |
| FA35 | 4/6 spiral, wire ¹ | DIN EN 1829-2 | | | | | | | | | | | | |
| CEM69TC | 6 spiral, wire | API 7K FSL0 - ISO 14693 | | | | | | | | X | | | | |

1: The hose construction depends on the hose ID (size). 2: The standard depends on the hose ID (size). For details, please refer to the respective hose page in this catalogue.

Technical handbook



Conversion chart

| | Unit | Base unit | Conversion unit | Factor |
|--------------------|--------------------------|-----------------|-----------------|----------------|
| Length | 1 inch | in | mm | 25.4 |
| | 1 millimetre | mm | in | 0.03934 |
| | 1 foot | ft | m | 0.3048 |
| | 1 metre | m | ft | 3.28084 |
| Area | 1 square inch | sq in | cm ² | 6.4516 |
| | 1 square centimetre | cm ² | sq in | 0.1550 |
| Volume | 1 gallon (UK) | gal | l | 4.54596 |
| | 1 litre | l | gal (UK) | 0.219976 |
| | 1 gallon (US) | gal | l | 3.78533 |
| | 1 litre | l | gal (US) | 0.264177 |
| Weight | 1 pound | lb | kg | 0.453592 |
| | 1 kilogramme | kg | lb | 2.204622 |
| Torque | 1 pound foot | lb • ft | N • m | 1.488164 |
| | 1 Newton metre | N • m | lb • ft | 0.671969 |
| Pressure | 1 pound per square inch | psi | bar | 0.06895 |
| | 1 bar | bar | psi | 14.5035 |
| | 1 pound per square inch | psi | MPa | 0.006895 |
| | 1 mega pascal | MPa | psi | 145.035 |
| | 1 kilo pascal | kPa | bar | 0.01 |
| | 1 bar | bar | kPa | 100 |
| | 1 mega pascal | MPa | bar | 10 |
| Velocity | 1 foot per second | ft / s | m / s | 0.3048 |
| | 1 metre per second | m / s | ft / s | 3.28084 |
| Flow rate | 1 gallon per minute (UK) | gal / min. | l / min. | 4.54596 |
| | 1 litre per minute | l / min. | gal / min. (UK) | 0.219976 |
| | 1 gallon per minute (US) | gal / min. | l / min. | 3.78533 |
| | 1 litre per minute | l / min. | gal / min. (US) | 0.264178 |
| Temperature | Fahrenheit degree | °F | °C | 5/9 • (°F-32) |
| | Celsius degree | °C | °F | °C • (9/5) +32 |

(UK) Unit of United Kingdom

(US) Unit of USA

Temperature and pressure chart

Reference 201, 206, 213 and 293 hose.

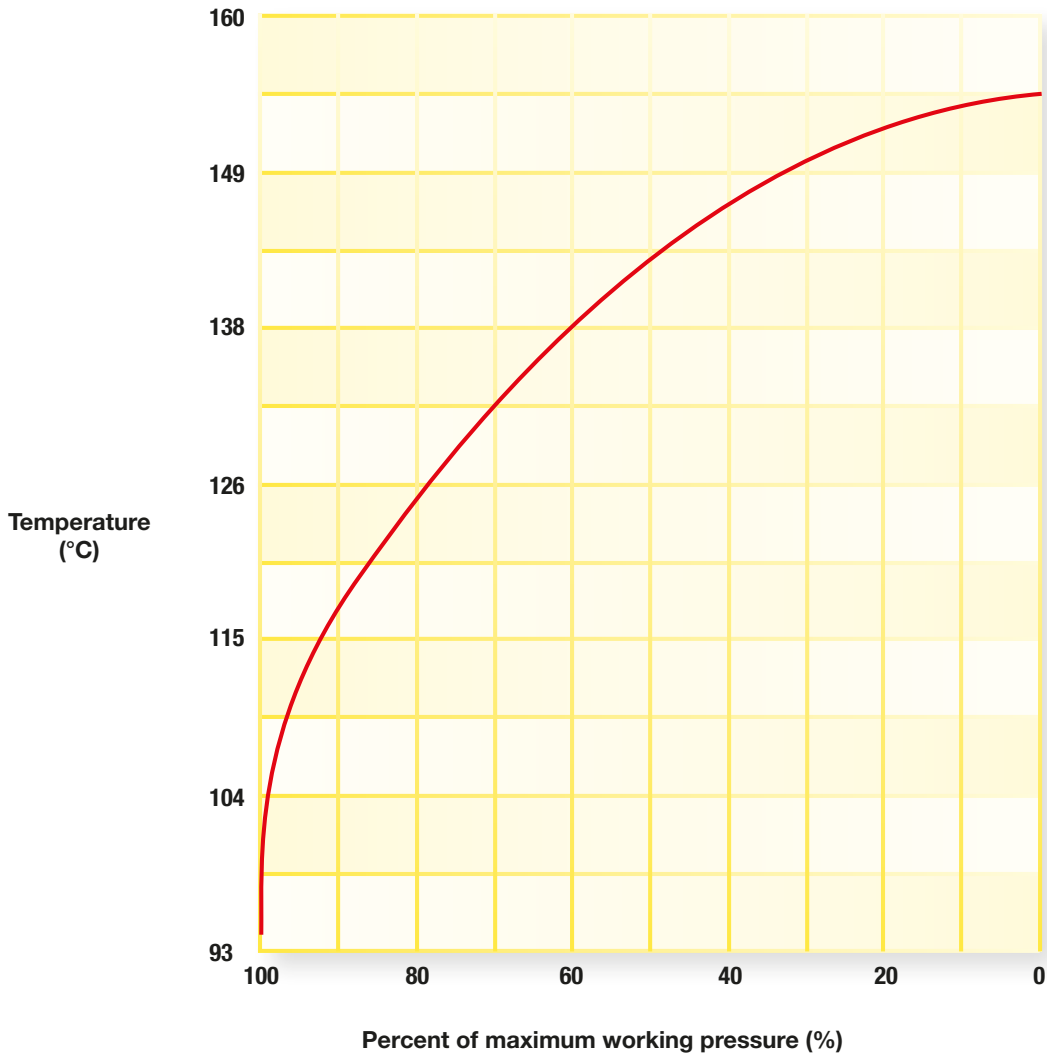

EXAMPLE: 201-8 hose to be used at 121 °C

| | | | | |
|---------------------------------------|---|----------------------------------|---|------------------------------------|
| Maximum Working Pressure up to 100 °C | x | Multiplication Factor from Chart | = | Maximum Working Pressure at 121 °C |
| 13.8 MPa (2000 psi) | x | 85% | = | 11.7 MPa (1700 psi) |

Flow capacity nomogram

The chart below is provided as an aid in the determination of the correct hose size.

Example: at 10 gallons per minute (gal/min), what is the proper hose size within the recommended velocity range for pressure lines?

Locate 10 gallons per minute in the left-hand column and 20 feet per second in the right-hand column (the maximum recommended velocity range for pressure lines). Lay a straight line across these two points.

The inside diameter shown in the centre column is above -6 so we have to use -8 (1/2"). For suction hose, follow the same procedure except use recommended velocity range for intake lines in the right-hand column.

where: Q = flow in gallons per minute (gal/min & l/min)

V = velocity in feet per second (f/s & m/s)

d = hose inside diameter (mm & dash size)

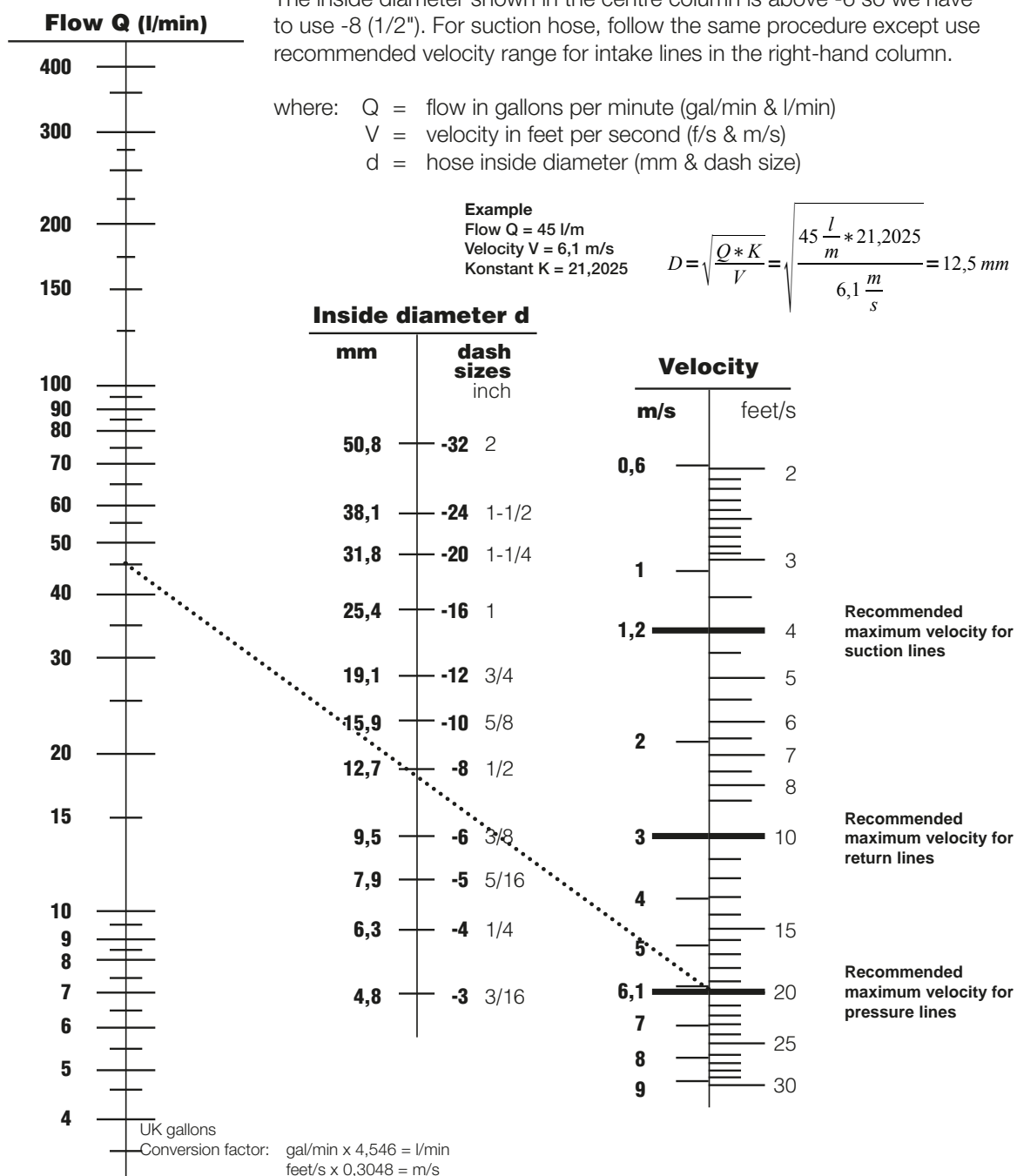

* Recommended velocities are according to hydraulic fluids of maximum viscosity 315 S.S.U. at 38°C working at roomtemperature within 18° and 68°C.

The correct method to fit female swivel ends

To ensure a leakproof seal between swivel female hose ends shown in this catalogue and the appropriate adaptors it is necessary to follow the procedure below which is different from hydraulic tube assembly.

Flats From Wrench Resistance (FFWR)

Parker's recommended assembly method for JIC 37° flare, SAE 45° flare and ORFS swivel female is Flats From Wrench Resistance (FFWR). The torque values assigned by size are for reference only, and are only

applicable to Parker system components using the FFWR method with trivalent chromate passivation on zinc plating of carbon steel components without lubrication.

Metal-to-metal seal

Screw the nut up hand tight and then tighten further with a spanner according to the values mentioned in the table below. Ensure that in all cases the hose is correctly aligned before tightening the nut onto the corresponding adaptor.

Spanner torque values

Metric swivel female

| Thread metric | Tube O.D. | Nm | |
|---------------|-----------|---------|-------------|
| | | nominal | min. - max. |
| M 12x1.5 | 06L | 16 | 15 - 17 |
| M 14x1.5 | 08L | 16 | 15 - 17 |
| M 16x1.5 | 10L | 26 | 25 - 28 |
| M 18x1.5 | 12L | 37 | 35 - 39 |
| M 22x1.5 | 15L | 47 | 45 - 50 |
| M 26x1.5 | 18L | 89 | 85 - 94 |
| M 30x2 | 22L | 116 | 110 - 121 |
| M 36x2 | 28L | 137 | 130 - 143 |
| M 45x2 | 35L | 226 | 215 - 237 |
| M 52x2 | 42L | 347 | 330 - 363 |
| M 14x1.5 | 06S | 26 | 25 - 28 |
| M 16x1.5 | 08S | 42 | 40 - 44 |
| M 18x1.5 | 10S | 53 | 50 - 55 |
| M 20x1.5 | 12S | 63 | 60 - 66 |
| M 22x1.5 | 14S | 79 | 75 - 83 |
| M 24x1.5 | 16S | 84 | 80 - 88 |
| M 30x2 | 20S | 126 | 120 - 132 |
| M 36x2 | 25S | 179 | 170 - 187 |
| M 42x2 | 30S | 263 | 250 - 275 |
| M 52x2 | 38S | 368 | 350 - 385 |

BSP swivel female

| Thread BSPP | size | Nm | |
|-------------|------|---------|-------------|
| | | nominal | min. - max. |
| G1/4 | -4 | 20 | 15 - 25 |
| G3/8 | -6 | 34 | 27 - 41 |
| G1/2 | -8 | 60 | 42 - 76 |
| G5/8 | -10 | 69 | 44 - 94 |
| G3/4 | -12 | 115 | 95 - 135 |
| G1 | -16 | 140 | 115 - 165 |
| G1-1/4 | -20 | 210 | 140 - 280 |
| G1-1/2 | -24 | 290 | 215 - 365 |
| G2 | -32 | 400 | 300 - 500 |

Note

Values given in tables are typical to achieve the recommended assembly methods when fitting material is steel zinc plated. For other materials different values will be applicable (see our recommendations for other materials on this page).

JIC 37° swivel female

| Thread UNF | size | Flats From Wrench Resistance (FFWR) | Swivel Nut Torque Nm (Ref) |
|------------|------|-------------------------------------|----------------------------|
| 7/16-20 | -4 | 2 | 18 |
| 1/2-20 | -5 | 2 | 20 |
| 9/16-18 | -6 | 1-1/2 | 30 |
| 3/4-16 | -8 | 1-1/2 | 57 |
| 7/8-14 | -10 | 1-1/2 | 81 |
| 1.1/16-12 | -12 | 1-1/4 | 114 |
| 1.5/16-12 | -16 | 1 | 160 |
| 1.5/8-12 | -20 | 1 | 228 |
| 1.7/8-12 | -24 | 1 | 265 |
| 2.1/2-12 | -32 | 1 | 360 |

ORFS swivel female

| Thread UNF | size | Flats From Wrench Resistance (FFWR) | Swivel Nut Torque Nm (Ref) |
|------------|------|-------------------------------------|----------------------------|
| 9/16-18 | -4 | 1/2 to 3/4 | 25 |
| 11/16-16 | -6 | 1/2 to 3/4 | 40 |
| 13/16-16 | -8 | 1/2 to 3/4 | 55 |
| 1-14 | -10 | 1/2 to 3/4 | 80 |
| 1.3/16-12 | -12 | 1/3 to 1/2 | 115 |
| 1.7/16-12 | -16 | 1/3 to 1/2 | 150 |
| 1.11/16-12 | -20 | 1/3 to 1/2 | 205 |
| 2-12 | -24 | 1/3 to 1/2 | 315 |
| 2-1/2x12 | -32 | - | - |

Note: The assembly torques listed for UNF threads are higher than the test torques published in SAE J1453.

The torque values for other materials are as follows:

- Brass fittings and adapters
65 % of the torque value for steel
- Stainless steel and Monel
Use 5% higher than listed for steel.
Threads to be lubricated for these materials.
- Dissimilar metals
Use torque value designated for the lower of the two metals.
- All fittings are dry except as noted above.

The correct method to fit ISO 6162-1 flange

| | | | |
|-------------------------------------------------------------------------------------------------------------------------------------------------------------------------------------------------------------------|-----------------------------------------------------------------------------------------------------------------------------------------------------------|-----------------------------------------------------------------------------------------------------------------------------------------------------------------------------------------|--------------------------------------------------------------------------------------|
| | | | |
| <ul style="list-style-type: none"> • Make sure sealing surfaces are free of burrs, nicks, scratches or any contamination • Lubricate the O-ring with system fluid or compatible lubricant | <ul style="list-style-type: none"> • Position flange and clamp halves • Place lock washers on bolts and bolt through clamp halves | <ul style="list-style-type: none"> • Hand tighten bolts • Torque bolts in diagonal sequence in small increments to the appropriate torque level listed in chart | <ul style="list-style-type: none"> • Tighten bolts according to chart |

Spanner torque values

ISO 6162-1 flange

| DN | Inch | Size | G Thread metric | Assembly torque Tolerances: max. 10%; min. 0% Nm | G Thread UNC (Inch) | Assembly torque Tolerances: max. 10%; min. 0% Nm |
|-----|-------|------|------------------------|-----------------------------------------------------------|----------------------------|-----------------------------------------------------------|
| | | | 13 | 1/2 | -8 | M8x1.25 |
| 19 | 3/4 | -12 | M10x1.5 | 50 | 3/8-16 | 43 |
| 25 | 1 | -16 | M10x1.5 | 50 | 3/8-16 | 43 |
| 32 | 1-1/4 | -20 | M10x1.5 | 50 | 7/16-14 | 70 |
| 38 | 1-1/2 | -24 | M12x1.75 | 92 | 1/2-13 | 105 |
| 51 | 2 | -32 | M12x1.75 | 92 | 1/2-13 | 105 |
| 64 | 2-1/2 | -40 | M12x1.75 | 92 | 1/2-13 | 105 |
| 76 | 3 | -48 | M16x2 | 210 | 5/8-11 | 210 |
| 89 | 3-1/2 | -56 | M16x2 | 210 | 5/8-11 | 210 |
| 102 | 4 | -64 | M16x2 | 210 | 5/8-11 | 210 |
| 127 | 5 | -80 | M16x2 | 210 | 5/8-11 | 210 |

ISO 6162-1 flange 5000 psi

| DN | Inch | Size | G Thread metric | Assembly torque Tolerances: max. 10%; min. 0% Nm | G Thread UNC (Inch) | Assembly torque Tolerances: max. 10%; min. 0% Nm |
|----|-------|------|------------------------|-----------------------------------------------------------|----------------------------|-----------------------------------------------------------|
| | | | 32 | 1-1/4 | -20 | - |
| 38 | 1-1/2 | -24 | - | - | 1/2-13 | 105 |
| 51 | 2 | -32 | - | - | 1/2-13 | 105 |

The correct method to fit ISO 6162-2 flange

| | | | |
|-------------------------------------------------------------------------------------------------------------------------------------------------------------------------------------------------------------------|-----------------------------------------------------------------------------------------------------------------------------------------------------------|-----------------------------------------------------------------------------------------------------------------------------------------------------------------------------------------|--------------------------------------------------------------------------------------|
| | | | |
| <ul style="list-style-type: none"> • Make sure sealing surfaces are free of burrs, nicks, scratches or any contamination • Lubricate the O-ring with system fluid or compatible lubricant | <ul style="list-style-type: none"> • Position flange and clamp halves • Place lock washers on bolts and bolt through clamp halves | <ul style="list-style-type: none"> • Hand tighten bolts • Torque bolts in diagonal sequence in small increments to the appropriate torque level listed in chart | <ul style="list-style-type: none"> • Tighten bolts according to chart |

Spanner torque values

ISO 6162-2 flange

| DN | Inch | Size | G Thread | | Assembly torque Tolerances: max. 10%; min. 0% | Nm |
|----|-------|------|----------|------------|-----------------------------------------------------|-----|
| | | | metric | UNC (Inch) | | |
| 13 | 1/2 | -8 | M8x1.25 | 5/16-18 | 24 | 24 |
| 19 | 3/4 | -12 | M10x1.5 | 3/8-16 | 50 | 43 |
| 25 | 1 | -16 | M12x1.75 | 7/16-14 | 92 | 70 |
| 32 | 1-1/4 | -20 | M12x1.75 | 1/2-13 | 130 | 105 |
| 32 | 1-1/4 | -20 | M14x2 | - | 150 | - |
| 38 | 1-1/2 | -24 | M16x2 | 5/8-11 | 210.0 | 210 |
| 51 | 2 | -32 | M20x2.5 | 3/4-10 | 400.0 | 360 |
| 64 | 2-1/2 | -40 | M24x3 | - | 600.0 | - |
| 76 | 3 | -48 | M30x3.5 | - | 650.0 | - |

ISO 6162-2 flange 8000 psi

| DN | Inch | Size | G Thread | | Assembly torque Tolerances: max. 10%; min. 0% | Nm |
|----|-------|------|----------|------------|-----------------------------------------------------|----|
| | | | metric | UNC (Inch) | | |
| 19 | 3/4 | -12 | M10x1.5 | 3/8-16 | 60 | - |
| 25 | 1 | -16 | M12x1.75 | 7/16-14 | 92 | - |
| 32 | 1-1/4 | -20 | M12x1.75 | 1/2-13 | 130 | - |
| 32 | 1-1/4 | -20 | M14x2 | - | 150 | - |

Chemical resistance table

Warning ! This chemical compatibility guide must not be used in conjunction with any other compatibility guides from previous or future catalogue editions, bulletins or publications. Incorrect use of these charts could result in death, personal injury or property damage.

Hose selection by medium and hose type

This hose compatibility chart is a ready reference of Parker hose compatibility with various fluid media. It is intended as a guide to chemical compatibility with inner tube materials and assembly lubricants applied internally.

The outer cover of the hose is intended to protect the reinforcement layer(s) from mechanical influences (abrasion, weathering etc), as such the cover compounds are not designed to exhibit the same chemical resistance as the tube compounds. The Hose Division Technical Department should be consulted about the compatibility of the cover should the application involve the extended exposure or immersion in a liquid.

The specific recommendations are based upon field experience, the advice of various polymer or fluid suppliers, and specific laboratory experiments. It must be stressed, however, that this information is offered only as a guide. Final hose selection depends also upon pressure, fluid temperature, ambient temperature, and special requirements or variations, which may not be known by Parker. Legal and other regulations must be followed with particular care.

Where an external compatibility problem may occur, or for fluids not listed, we encourage you to first contact the fluid manufacturer for a recommendation prior to contacting your Parker Field Representative or the Technical Department, Polymer Hose Division Europe.

Use the chart as follows:

1. Locate medium to be carried using the Chemical Resistance Table on the following pages.
2. Select suitability of hose and fitting material from the table based on the letter rating in the table. See resistance rating key below for explanation of compatibility ratings. See list of numerals below for an explanation when a numeral, or a numeral and a letter rating are present in the table.
3. The Column headings on the Chemical Resistance Table, I, II, III, IV, V refer to specific groups of hoses.
4. Locate hose part number under Column I, II, III, IV, V, VI from the list below.
5. For fitting material availability refer to appropriate fitting section of catalogue.
6. Check hose specifications in this catalogue. Contact Polymer Hose Division Europe Technical Department on any items not catalogued.

Resistance rating key

A = Preferred, good to excellent with little or no change in physical properties.

F = Fair, marginal or conditional with noticeable effects on physical properties.

X = Unsuitable, severe effects on physical properties.

~ = No rating, insufficient information.

Numerals

1. For air or gaseous applications above 250 psi (1.7 MPa), the cover should be pin pricked.
2. Legal and insurance regulations must be considered. Contact PHDE Technical Department for more information.
3. Push-Lok hoses (801PLUS, 804, 821FR, 831, 836, 837BM, 837PU, 830M, 838M) are not recommended for any type of fuel.
4. Use 285 hose. The compatibility of the system's refrigeration oil with these hoses needs to be evaluated on a case by case basis. Contact PHDE Technical Department for more information. Chemical compatibility does not imply low permeation.
5. 65 °C (150 °F) maximum.
6. Satisfactory at some concentrations and temperatures, unsatisfactory at others.
7. For phosphate ester fluids use 304, 774, 804 or F42 hoses.
8. Acceptable for flushing hose assemblies.
9. 221FR hose recommended.
10. For dry air applications, hoses with inner tubes from columns IV and V are preferred. See hose specifications for maximum recommended temperatures with air.
11. 100 °C (212 °F) maximum.
12. 121 °C (250 °F) maximum.
13. Hoses for gas application are available from Parker. Please contact the Technical Department for more information about the products as well as the legal application requirements.
14. 70 °C maximum for hoses 837BM, 837PU
15. No rating / insufficient information about chemical compatibility for hoses 837BM, 837PU.

Hose types

Column I: 201, 701, 701TC, 731, 731TC, 881, H31, H29, R35, RD35TC, RS35TC, R42, H31TC, H29TC, R35TC, R42TC, H31ST, H29ST, R42ST, R50TC, R56TC, BPK, SX35, SX35LT, SX35TC, SX42, SX42LT, SX42TC, FA35

Column II: 371LT, 421TC, 421WC, 441, 441RH, 461LT, 471TC, 493, 681, 681DB, 811, 811S, HT2

Column III: BCH1, BCH2, 187, 187TC, 187ST, 221FR, 301SN, 372, 372RH, 372TC, 387, 387ST, 387TC, 412, 412ST, 421RH, 421SN, 421TC, 462, 462ST, 462TC, 462PU, 462PU Twin, 463, 477, 477ST, 477TC, 477RH, 487, 487TC, 487ST, 492, 492ST, 492TC, 493, 692, 692TC, 692Twin, 692PU, 602PU Twin, 722, 787, 787TC, 787ST, 797, 797TC, 797ST, 797RH, 801PLUS, 801RH

Column IV: 206, 213, 293, 426, 436, 611HT, 821FR, 836, 837BM*, 837PU*, 846

Column V: 304, 774, 804, F42

Column VI: 830M, 838M

Note: * See Numeral 15

Caution: The fluid manufacturer's recommended maximum operating temperature for any specific name-brand fluid should be closely observed by the user. Specific name brand fluids can vary greatly between manufacturers even though they are considered to be from the same family of fluids. Using fluids above the manufacturer's maximum recommended temperature can cause the fluid to break down, creating by-products that can be harmful to elastomers or other materials used in the system. When selecting a hose type, both the fluid manufacturer and hose manufacturer's maximum temperature limit must be taken into consideration, with the lower of the two taking precedence.



| Medium | I | II | III | IV | V | VI | STEEL | BRASS | SS |
|---------------------------------------------|----------|----------|----------|----------|----------|----|-------|-------|----|
| 3M FC-75 | A | A | A | A 15 | A | A | A | A | A |
| A | | | | | | | | | |
| Acetic Acid | X | X | X | A 15 | 6 | X | X | X | A |
| Acetone | X | X | X | A 15 | A | X | A | A | A |
| Acetylene | X | X | X | X | X | - | - | - | - |
| AEROSHELL Turbine Oil 500 (See MIL-L-23699) | X | X | F | X | X | - | A | A | A |
| Agip Arnica 46 | A | A | A | A | X | A | | | |
| Agip synth 2000 | A | A | A | A | X | A | | | |
| Air | A, 1, 10 | A, 1, 10 | A, 1, 10 | A, 1, 10 | A, 1, 10 | A | A | A | A |
| Air (dry) | X | F, 1, 10 | F, 1, 10 | A, 1, 10 | A, 1, 10 | A | A | A | A |
| AEROSHELL Fluid 41 | - | F | A | - | - | - | | | |
| Alusol M | - | A | A | - | - | - | | | |
| Alcohol (Methanol-Ethanol) | F | F | F | A 15 | F | - | F | A | A |
| Ammonia (Anhydrous) | X | X | X | X | X | - | X | X | X |
| Ammonium Chloride | A | A | A | A 15 | A | A | X | X | X |
| Ammonium Hydroxide | F | F | F | A 15 | A | X | F | X | A |
| Ammonium Nitrate | A | A | A | A 15 | A | - | F | X | A |
| Ammonium Phosphate | A | A | A | A 15 | A | - | X | X | F |
| Ammonium Sulfate | A | A | A | A 15 | A | - | F | X | F |
| Ambra Multi G (NH 410 B) | - | A | A | - | - | - | | | |
| Amoco 32 Rykon | X | A | A | F 14 | X | A | A | A | A |
| Ampol PE 46 | X | X | X | X | A, 7 | F | A | A | A |
| AMSOIL Synthetic ATF | F | A | A | A 15 | X | F | A | A | A |
| Amyl Alcohol | X | X | X | A 15 | F | - | X | A | A |
| Anderol 495,497,500,750 | X | X | F | A 15 | X | X | A | A | A |
| Aniline | X | X | X | A 15 | A | X | A | X | A |
| Animal Fats | X | F | F | A 15 | F | - | 6 | 6 | A |
| Aquacent Light, Heavy | X | A | A | X | X | A | A | A | A |
| Aral Vitam HF46 | A | A | A | X | X | F | | | |
| Argon | A | A | A | A | A | A | A | A | A |
| Aromatic 100,150 | X | F | F | - | X | F | A | A | A |
| Arrow 602P | A | A | A | A 14 | X | A | A | A | A |
| Asphalt | X | F | F | F 14 | X | A | F | F | A |
| ASTM #3 Oil | F | F | F | A 15 | X | - | A | A | A |
| ATF-M | F | A | A | A 14 | X | A | A | A | A |
| Avantin 361 | - | A | A | - | - | - | | | |
| Avia Syntofluid PE B50 | A | A | A | - | - | - | | | |
| Avialith 2 WC | - | A | A | - | - | - | | | |
| Automotive Brake Fluid | X | X | X | X | - | X | X | X | X |
| AW 32,46,68 | F | A | A | A 14 | X | A | A | A | A |
| B | | | | | | | | | |
| BCF | F | F | F | F 15 | - | - | A | A | A |
| Benz Petraulic 32,46,68,100,150,220,320,460 | F | A | A | A 14 | X | A | A | A | A |
| Benzene, Benzol | X | X | X | A 15 | X | F | A | A | A |
| Benzgrind HP 15 | - | A | A | A 15 | X | - | A | A | A |
| Benzine | X | X | X | F 15 | X | - | A | A | A |
| Biodegradable Hydraulic Fluid 112B | X | A | A | X | - | - | A | A | A |
| Biodiesel E20 | X | F | X | X | X | X | - | - | - |
| Biodiesel E100 | X | F | X | X | X | X | - | - | - |
| Biodiesel E60 | X | F | X | X | X | X | - | - | - |
| Biodiesel E80 | X | F | X | X | X | X | - | - | - |
| Borax | F | F | F | A 15 | A | - | F | A | A |
| Boric Acid | A | A | A | X | A | X | X | 6 | A |
| Brayco 882 | X | A | A | A 15 | X | - | A | A | A |
| Brayco Micronic 745 | X | X | A | F 14 | X | A | A | A | A |
| Brayco Micronic 776RP | F | A | A | F 14 | X | A | A | A | A |
| Brayco Micronic 889 | X | F | F | - | X | - | A | A | A |
| Brine | F | F | F | A 15 | A | - | X | F | F |

| Medium | I | II | III | IV | V | VI | STEEL | BRASS | SS | |
|--------------------------------------------------|------------|-------|-------|----------|------|------|-------|-------|----|---|
| Butane | See 2 & 13 | | | | | | F | A | A | A |
| Butyl Alcohol, Butanol | F | F | F | A 15 | F | - | F | F | A | |
| C | | | | | | | | | | |
| Calcium Chloride | A | A | A | A 15 | A | - | F | F | X | |
| Calcium Hydroxide | A | A | A | A 15 | A | - | A | A | A | |
| Calcium Hypochlorite | X | X | X | A 15 | A | - | X | F | X | |
| Calibrating Fluid | A | A | A | A 14 | X | A | A | A | A | |
| Carbon Dioxide, gas | F | F | F | F 15 | 6 | - | A | A | A | |
| Carbon Disulfide | X | X | X | A 15 | X | - | A | F | A | |
| Carbon Monoxide (hot) | F | F | F | A 15 | 6 | - | F | 6 | A | |
| Carbon Tetrachloride | X | X | X | A 15 | X | - | 6 | 6 | 6 | |
| Carbonic Acid | F | F | F | X | F | X | X | X | F | |
| Castor Oil | A | A | A | A 15 | A | - | A | A | A | |
| Castrol 5000 | X | F | F | A 15 | X | X | A | A | A | |
| Castrol Wendax | - | A | A | - | - | - | | | | |
| Cellosolve Acetate | X | X | X | X | A | - | X | X | A | |
| Cellugard | A | A | A | - | A | - | A | A | A | |
| Cellulube 90, 150, 220 300, 550, 1000 | X | X | X | - | A | - | A | A | A | |
| Chevron Clarity AW 32, 46, 68 | A | A | A | A 14 | X | A | A | A | A | |
| Chevron FLO-COOL 180 | F | F | F | - | X | - | A | A | A | |
| Chevron FR-8, 10, 13, 20 | X | X | X | X | A, 7 | F | A | A | A | |
| Chevron Hydraulic Oils AW MV 15, 32, 46, 68, 100 | A | A | A | A 14 | X | A | A | A | A | |
| Chevron HyJet IV (9) | X | X | X | X | A, 7 | F | A | A | A | |
| Citric Acid | F | A | A | X | A | X | X | X | 6 | |
| Commonwealth EDM 242, 244 | A | A | A | - | X | A | A | A | A | |
| CompAir CN300 | X | X | X | A 15 | X | X | A | A | A | |
| CompAir CS100, 200, 300, 400 | X | X | X | A 15 | X | X | A | A | A | |
| Condat D46 - D68 | F | A | A | - | - | - | | | | |
| Coolanol 15, 20, 25, 35, 45 | A | A | A | A 15 | A | X | A | A | A | |
| Copper Chloride | F | A | A | X | A | - | X | X | X | |
| Copper Sulfate | A | A | A | X | A | - | X | X | F | |
| Cosmolubric HF-122, HF-130, HF-144 | X | F | A | X | X | - | A | A | A | |
| Cosmolubric HF-1530 | X | F | A | X | X | - | A | A | A | |
| Cottonseed Oil | F | A | A | F 15 | X | - | A | A | A | |
| CPI CP-4000 | X | X | X | A 15 | X | - | A | A | A | |
| Crude Petroleum Oil | F | A | A | A 14 | X | A | F | F | A | |
| CSS 1001 Dairy Hydraulic Fluid | F | A | A | A 15 | X | - | A | A | A | |
| D | | | | | | | | | | |
| Daphne AW32 | A | A | A | A 14 | X | A | A | A | A | |
| Dasco FR 201-A | A | A | A | - | X | - | A | A | A | |
| Dasco FR150, 200, 310 | F | A | A | - | A | - | A | A | A | |
| Dasco FR300, FR2550 | X | X | X | - | X | F | A | A | A | |
| Dasco FR355-3 | X | F | A | X | X | X | A | A | A | |
| Deicer Fluid 419R | A | A | A | - | - | A | A | A | A | |
| Deionized Water | A | A | A | A 15 | A | - | F | F | A | |
| Dexron II ATF | F | A | A | A 14 | X | A | A | A | A | |
| Dexron III ATF | X | F, 11 | F, 11 | A 15, 12 | X | - | A | A | A | |
| Diesel Fuel | F, 3 | A, 3 | A, 3 | A 15, 3 | X | A(2) | A | A | A | |
| Diester Fluids | X | X | X | X | X | X | A | A | A | |
| Divinol HLP 46 | - | A | A | - | - | - | | | | |
| DOT III-IV | X | X | X | X | F | - | | | | |
| Dow Corning 2-1802 Sullair (24KT) | - | - | - | F 15 | - | - | A | A | A | |
| Dow Corning DC 200, 510, 550, 560, FC126 | A | A | A | A 15 | - | - | A | A | A | |
| Dow HD50-4 | F | F | F | - | - | - | - | - | A | |
| Dow Sullube 32 | - | - | - | F 15 | - | - | A | A | A | |
| Dowtherm A,E | X | X | X | A 15 | X | - | A | A | A | |
| Dowtherm G | X | X | X | X | X | - | A | A | A | |
| Duro AW-16, 31 | A | A | A | - | X | - | A | A | A | |

| Medium | I | II | III | IV | V | VI | STEEL | BRASS | SS |
|----------------------------------------------------|------|-------|------|---------|------|------|-------|-------|----|
| Duro FR-HD | A | A | A | - | X | - | A | A | A |
| E | | | | | | | | | |
| EcoSafe FR-68 | A | A | A | - | X | X | A | A | A |
| Ethanol | F | F | F | A 15 | F | - | F | A | A |
| Ethers | X | X | X | A 15 | X | - | A | A | A |
| Ethyl Acetate | X | X | X | A 15 | F | - | F | A | A |
| Ethyl Alcohol | F | F | F | A 15 | F | - | F | A | A |
| Ethyl Cellulose | F | F | F | A 15 | F | - | X | F | F |
| Ethyl Chloride | X | X | X | X | A | - | F | F | F |
| Ethylene Dichloride | X | X | X | A 15 | X | - | X | A | X |
| Ethylene Glycol | F | A | A | A | A | A | A | F | A |
| Exxon 3110 FR | A | A | A | A 15 | X | A | A | A | A |
| Exxon Esstic | A | A | A | A 14 | A | A | A | A | A |
| Exxon Nuto H 46, 68 | A | A | A | A 14 | X | A | A | A | A |
| Exxon Tellura Industrial Process Oils | A | A | A | A 14 | X | A | A | A | A |
| Exxon Terresstic, EP | A | A | A | A 14 | A | A | A | A | A |
| Exxon Turbo Oil 2380 | X | F | F | A 15 | X | X | A | A | A |
| Exxon Univolt 60, N61 | F | A | A | A 14 | X | A | A | A | A |
| F | | | | | | | | | |
| FE 232 (Halon) | X | X | X | X | F | - | A | A | A |
| Fenso 150 | - | A | A | - | X | A | A | A | A |
| Formaldehyde | X | X | X | A 15 | A | - | X | F | A |
| Formic Acid | X | X | X | X | A | X | X | 6 | X |
| Freons see refrigerants | - | - | - | - | - | - | - | - | - |
| Fuel Oil | F, 3 | A, 3 | A, 3 | A 15, 3 | X | A(2) | A | A | A |
| Fyre-Safe 120C, 126, 155, 1090E, 1150, 1220, 1300E | X | X | X | X | A, 7 | F | A | A | A |
| Fyre-Safe 200C, 225, 211 | F | A | A | A | A | F | A | A | A |
| Fyre-Safe W/O | A | A | A | A 15 | X | A | A | A | A |
| Fyrguard 150, 150-M, 200 | A | A | A | A | A | F | A | A | A |
| Fyrquel 60, 90, 150, 220, 300, 550, 1000 | X | X | X | X | A, 7 | F | A | A | A |
| Fyrquel EHC, GT, LT, VPF | X | X | X | X | A, 7 | F | A | A | A |
| Fyrtek MF, 215, 290, 295 | X | X | X | X | X | F | A | A | A |
| G | | | | | | | | | |
| Gardner-Denver GD5000, GD8000 | X | X | X | A 15 | X | X | A | A | A |
| Gasoline | | See 9 | | | | - | A | A | A |
| Glue | F | F | F | - | X | - | A | F | A |
| Glycerine, Glycerol | A | A | A | A 15 | A | - | A | F | A |
| Grease | A | A | A | A 14 | X | A | A | A | A |
| Gulf-FR Fluid P37, P40, P43, P45, P47 | X | X | X | A 15 | A | - | A | A | A |
| H | | | | | | | | | |
| H-515 (NATO) | A | A | A | - | X | - | A | A | A |
| Halon 1211, 1301 | F | F | F | F 15 | - | - | A | A | A |
| Helium Gas | X | X | X | X | X | - | A | A | A |
| Heptane | X | F | F | A 15 | X | - | A | A | A |
| Hexane | X | F | F | A 15 | X | - | A | A | A |
| HF-20, HF-28 | | A | A | A | A | F | A | A | A |
| Houghto-Safe 1055, 1110, 1115, 1120, 1130 (9) | X | X | X | X | A, 7 | F | A | A | A |
| Houghto-Safe 271 to 640 | F | A | A | A | A | F | A | A | A |
| Houghto-Safe 419 Hydraulic Fluid | A | A | A | - | X | - | A | A | A |
| Houghto-Safe 419R Deicer Fluid | A | A | A | - | - | A | A | A | A |
| Houghto-Safe 5046, 5046W, 5047-F | A | A | A | A 15 | X | - | A | A | A |
| HP 100C (Jack hammer oil) | F | A | A | A 14 | X | A | A | A | A |
| HPWG 46B | F | A | A | A | - | F | A | A | A |
| Hul-E-Mul | A | A | A | - | X | - | A | A | A |
| Hychem C, EP1000, RDF | A | A | A | A 15 | A | - | A | A | A |
| Hycut SE 12 | F | A | A | - | - | - | | | |
| Hycut SE 46 | F | A | A | - | - | - | | | |
| Hydra Safe E-190 | A | A | A | A 15 | X | - | A | A | A |

| Medium | I | II | III | IV | V | VI | STEEL | BRASS | SS |
|-------------------------------------------|---|--------|-----|--------|------|------|-------|-------|----|
| Hydra-Cut 481, 496 | A | A | A | - | X | - | A | A | A |
| Hydrafluid 760 | A | A | A | - | X | - | A | A | A |
| Hydrochloric Acid | X | X | X | X | X | X | X | X | X |
| Hydrofluoric Acid | X | X | X | X | X | X | X | 6 | X |
| Hydrogen Gas | X | X | X | X | X | - | A | A | A |
| Hydrogen Peroxide | X | X | X | A 15 | X | - | X | X | 6 |
| Hydrogen Sulfide | X | X | X | X | A | - | X | X | 6 |
| Hydrolube | A | A | A | A 15 | A | - | A | A | A |
| Hydrolubric 120-B, 141, 595 | F | A | A | A 15 | A | - | A | A | A |
| Hydrosafe Glycol 200 | A | A | A | A | A | F | A | F | A |
| Hydrovane Fluid Force 2000 | - | A | A | - | - | - | - | - | - |
| HyJet IV | X | X | X | X | A, 7 | - | A | A | A |
| HT BRADOL (Virto) | - | A | A | - | - | - | - | - | - |
| I | | | | | | | | | |
| Ideal Yellow 77 | A | A | A | A 15 | X | - | A | A | A |
| Imol S150 to S550 | X | X | X | - | - | - | A | A | A |
| Ingersoll Rand SSR Coolant | X | X | X | A 15 | X | X | A | A | A |
| Isocyanates | X | X | X | A 15 | X | - | A | - | A |
| Isooctane | X | F | F | A 15 | X | - | A | A | A |
| Isopar H | X | X | X | X | X | - | A | A | A |
| Isopropyl Alcohol | F | F | F | A 15 | F | - | F | A | A |
| J | | | | | | | | | |
| Jayflex DIDP | X | X | X | X | A | - | A | A | A |
| JP3 and JP4 | X | A,3 | A,3 | - | X | A(2) | A | A | A |
| JP5 | X | A,3 | A,3 | F 15,3 | X | A(2) | A | A | A |
| JP9 | X | X | X | X | X | - | A | - | A |
| K | | | | | | | | | |
| Kaeser 150P, 175P, 325R, 687R | X | X | X | A 15 | X | - | A | A | A |
| Kerosene | X | A | A | F 14 | X | A | A | A | A |
| KSL-214, 219, 220, 222 | X | X | X | A 15 | X | - | A | A | A |
| L | | | | | | | | | |
| Lacquer | X | X | X | A 15 | X | - | X | A | A |
| Lacquer Solvents | X | X | X | A 15 | X | - | X | A | A |
| Lactic Acids | X | X | X | X | X | X | X | X | A |
| Lindol HF | X | X | X | A 15 | A | - | A | A | A |
| Linseed Oil | F | A | A | A 15 | A | - | A | A | A |
| LP-Gas | | See 13 | | | | - | A | A | A |
| M | | | | | | | | | |
| Magnesium Chloride | A | A | A | A 15 | A | - | X | X | X |
| Magnesium Hydroxide | F | F | F | A 15 | A | - | F | F | F |
| Magnesium Sulfate | A | A | A | A 15 | A | - | A | F | A |
| Mercaptans | X | X | X | X | X | - | - | - | - |
| Methane | | See 13 | | | | - | A | A | A |
| Methanol | A | F | A | A 15 | F | - | F | A | A |
| Methyl Alcohol | A | F | A | A 15 | F | - | F | A | A |
| Methyl Chloride | X | X | X | A 15 | X | - | A | A | A |
| Methyl Ethyl Ketone (MEK) | X | X | X | A 15 | X | - | F | A | A |
| Methyl Isopropyl-Ketone | X | X | X | X | X | - | F | A | A |
| Metsafe FR303, FR310, FR315, FR330, FR350 | X | X | X | X | X | F | A | A | A |
| Microzol-T46 | X | A | A | - | X | - | A | A | A |
| MIL-H-544 | - | A | A | - | - | - | - | - | - |
| MIL-B-46176A | X | X | X | X | X | - | X | X | X |
| MIL-H-46170 | X | F | F | A 15 | X | - | A | A | A |
| MIL-H-5606 | F | A | A | A 14 | X | A | A | A | A |
| MIL-H-6083 | F | A | A | A 15 | X | - | A | A | A |
| MIL-H-7083 | F | A | A | A 15 | X | - | A | A | A |
| MIL-H-83282 | F | A | A | A 15 | X | - | A | A | A |
| MIL-L-2104, 2104B | F | A | A | A 14 | X | A | A | A | A |

| Medium | I | II | III | IV | V | VI | STEEL | BRASS | SS |
|--------------------------------------------|------|--------|------|---------|------|----|-------|-------|----|
| MIL-L-23699 | X | X | X | X | X | X | A | A | A |
| MIL-L-7808 | F | A | A | - | X | - | A | A | A |
| Mine Guard FR | A | A | A | - | A | - | A | A | A |
| Mineral Oil | A | A | A | F 14 | X | A | A | A | A |
| Mineral Spirits | 8 | 8 | 8 | 8 | X | - | A | A | A |
| Mobil Aero HF | - | A | A | - | - | - | - | - | - |
| Mobil Aero HFE | F | A | A | F 14 | X | A | A | A | A |
| Mobil ATF 220 | - | A | A | - | - | - | - | - | - |
| Mobil DTE 11M, 13M, 15M, 16M, 18M, 19M | F | A | A | A 14 | X | A | A | A | A |
| Mobil DTE 22, 24, 25, 26 | F | A | A | A 14 | X | A | A | A | A |
| Mobil EAL 224H | X | A | A | X | - | - | A | A | A |
| Mobil EAL Artic 10, 15, 22,32, 46, 68, 100 | X | X | X | X | X | X | A | A | A |
| Mobil Glygoyle 11, 22, 30, 80 | X | F | F | - | X | - | A | A | A |
| Mobil HFA | F | A | A | A 15 | X | - | A | A | A |
| Mobil Jet 2 | X | F | F | A 15 | X | - | A | A | A |
| Mobil Nylvac 20, 30, 200, FR | F | A | A | A | A | F | A | A | A |
| Mobil Rarus 824, 826, 827 | X | X | X | A 15 | X | X | A | A | A |
| Mobil SHC 524 | - | A | A | - | - | - | - | - | - |
| Mobil SHC 600 Series | F | A | A | A 15 | X | - | A | A | A |
| Mobil SHC 800 Series | F | A | A | A 15 | X | - | A | A | A |
| Mobil Vactra Oil | A | A | A | F 14 | X | A | A | A | A |
| Mobil XRL 1618B | X | X | X | X | A, 7 | F | A | A | A |
| Mobilfluid 423 | F | A | A | A 14 | X | A | A | A | A |
| Mobilgear SHC 150, 220, 320, 460, 680 | F | F | F | A 15 | X | - | A | A | A |
| Mobilarma 525 | A | A | A | F 14 | X | A | A | A | A |
| Molub-Alloy 890 | X | X | X | A 15 | X | - | A | A | A |
| Moly Lube "HF" 902 | F | F | F | F 14 | X | A | A | A | A |
| Monolec 6120 Hydraulic Oil | A | A | A | A 14 | X | A | A | A | A |
| Morpholine (pure additive) | X | X | X | X | X | - | X | X | A |
| Motorex Corex HLP 46 | A | A | A | - | - | - | - | - | - |
| N | | | | | | | | | |
| Naptha | F | F | A | A 15 | X | - | A | A | A |
| Napthalene | X | X | X | A 15 | X | - | A | A | A |
| Natural Gas | | See 13 | | | | - | A | A | A |
| Nitric Acid | X | X | X | X | X | X | X | X | F |
| Nitrobenzene | X | X | X | A 15 | X | - | X | X | A |
| Neste SE 46 | F | A | A | - | - | - | - | - | - |
| Neste 46 32 | A | A | A | - | - | - | - | - | - |
| Nitrogen, gas | F, 1 | F, 1 | F, 1 | F 15, 1 | F, 1 | - | A | A | A |
| NORPAR 12, 13, 15 | 8 | 8 | 8 | 8 | X | - | A | A | A |
| Nuto H 46, 68 | A | A | A | A 14 | X | A | A | A | A |
| Nylvac 20, 30, 200, FR | F | A | A | A | A | F | A | A | A |
| Nylvac Light | X | X | X | - | A | - | A | A | A |
| O | | | | | | | | | |
| Oceanic HW | F | A | A | A | X | F | A | A | A |
| Oxygen, gas | A | X | X | X | X | - | X | A | A |
| Ozone | F | X | F | F | A | A | A | A | A |
| P | | | | | | | | | |
| Pacer SLC 150, 300, 500, 700 | X | X | X | A 15 | X | - | A | A | A |
| Panolin HLP 46 | F | A | A | - | - | - | - | - | - |
| Panolin TURWANDA SYNTH 46 | F | A | A | - | - | - | - | - | - |
| Pennzbell AWX | F | A | A | F 14 | X | A | A | A | A |
| PENTOSIN CHF 11S | F | A | A | F | A | X | A | A | A |
| Perchloroethylene | X | X | X | X | X | - | F | X | A |
| Petroleum Ether | X | F | F | F 14 | X | A | A | A | A |
| Petroleum Oils | A | A | A | A 14 | X | A | A | A | A |
| Phenol (Carbolic Acid) | X | X | X | A 15 | X | X | X | F | A |
| Phosphate Ester Blends | X | X | X | X | X | F | A | A | A |

| Medium | I | II | III | IV | V | VI | STEEL | BRASS | SS |
|---------------------------------------------|---|--------|------|------|------|----|-------|-------|----|
| Phosphate Esters | X | X | X | X | A, 7 | - | A | A | A |
| Phosphoric Acid 10 % | F | X | X | X | A | X | X | X | F |
| Plantosin HVI 46 | - | A | A | - | - | - | | | |
| Plexus 46 | F | A | A | - | - | - | | | |
| Polyalkylene Glycol | A | F | F | - | X | - | A | A | A |
| Polyol Ester | X | F | A | X | X | - | A | A | A |
| Potassium Chloride | A | A | A | A 15 | A | - | X | F | F |
| Potassium Hydroxide | X | X | X | A 15 | A | - | 6 | X | A |
| Potassium Sulfate | A | A | A | A 15 | A | - | A | A | A |
| Propane | | See 13 | | | | - | A | A | A |
| Propylene Glycol | A | A | A | A 15 | A | - | F | F | F |
| Pydraul 10-E, 29-E, 50-E, 65-E, 90-E, 115-E | X | X | X | X | A, 7 | F | A | A | A |
| Pydraul 230-C, 312-C, 68-S | X | X | X | X | A, 7 | F | A | A | A |
| Pydraul 60, 150, 625, F9 | X | X | X | X | A, 7 | - | A | A | A |
| Pydraul 90, 135, 230, 312, 540, MC | X | X | X | X | X | - | A | A | A |
| Pydraul A-200 | X | X | X | A 15 | X | - | A | A | A |
| Pyro Gard 43, 230, 630 | X | X | X | X | X | - | A | A | A |
| Pyro Gard C, D, R, 40S, 40W | F | A | A | F 15 | X | A | A | A | A |
| Pyro Guard 53, 55, 51, 42 | X | X | X | X | A, 7 | - | A | A | A |
| Q | | | | | | | | | |
| Q8 Holbein Bio Plus | F | A | A | - | - | - | | | |
| Quintolubric 700 | A | A | A | A 15 | A | - | A | F | A |
| Quintolubric 807-SN | F | A | A | - | X | - | A | A | A |
| Quintolubric 822, 855 | X | F, 5 | A, 5 | X | X | X | A | A | A |
| Quintolubric 888 | X | A, 5 | A, 5 | X | X | - | A | A | A |
| R | | | | | | | | | |
| Rando | A | A | A | A 14 | X | A | A | A | A |
| Rando HD 46 | - | A | A | - | - | - | | | |
| Rayco 782 | X | F | A | X | X | - | X | X | X |
| Renault ST 46M | A | A | A | - | - | - | | | |
| Renolin Lift | - | A | A | - | - | - | | | |
| Renolin HVI 46 | - | A | A | - | - | - | | | |
| Refrigerant 124 | | See 4 | | | | X | A | A | A |
| Refrigerant Freon 113, 114 | X | X | X | X | X | X | A | A | A |
| Refrigerant Freon 12 | | See 4 | | | | X | A | A | A |
| Refrigerant Freon 22 | | See 4 | | | | X | A | A | A |
| Refrigerant Freon 502 | | See 4 | | | | X | A | A | A |
| Refrigerant HFC134A | | See 4 | | | | X | A | A | A |
| Reolube Turbofluid 46 | X | X | X | X | A, 7 | - | A | A | A |
| Rivolta B.H.23 | F | A | A | - | - | - | | | |
| Rotella | A | A | A | A 14 | X | A | A | A | A |
| Royal Bio Guard 3032, 3046, 3068, 3100 | X | ~ | A | X | X | X | A | A | A |
| Royco 2200, 2210, 2222, 2232, 2246, 2268 | X | X | X | X | X | X | A | A | A |
| Royco 4032, 4068, 4100, 4150 | X | X | X | A 15 | X | X | A | A | A |
| Royco 756, 783 | A | A | A | A 14 | X | A | A | A | A |
| Royco 770 | X | F | F | F 15 | X | - | A | A | A |
| RTV Silicone Adhesive Sealants | X | X | X | X | X | - | A | A | A |
| S | | | | | | | | | |
| Safco-Safe T10, T20 | - | - | - | - | A | - | F | F | A |
| Safety-Kleen ISO 32, 46, 68 hydraulic oil | F | A | A | - | X | A | A | A | A |
| Safety-Kleen Solvent | 8 | 8 | 8 | - | X | 8 | A | A | A |
| Santoflex 13 | F | F | F | - | F | - | A | A | A |
| Santosafe 300 | X | X | X | - | X | - | A | A | A |
| Santosafe W/G 15 to 30 | - | - | - | A 15 | A | - | A | A | A |
| Sea Water | A | F | F | A 15 | A | A | X | F | A |
| Sewage | F | F | F | A 15 | F | - | X | F | A |
| Shell 140 Solvent | 8 | 8 | 8 | 8 | X | - | A | A | A |
| Shell Clavus HFC 68 | X | X | X | X | X | X | A | A | A |

| Medium | I | II | III | IV | V | VI | STEEL | BRASS | SS |
|--------------------------------------------|------|------|------|------|------|-----|-------|-------|----|
| Shell Comptella Oil | F | F | F | A 14 | X | A | A | A | A |
| Shell Comptella Oil S 46, 68 | F | F | F | A 14 | X | A | A | A | A |
| Shell Comptella Oil SM | F | F | F | A 14 | X | A | A | A | A |
| Shell Diala A, (R) Oil AX | F | A | A | F 14 | X | A | A | A | A |
| Shell FRM | - | - | - | - | X | - | A | A | A |
| Shell IRUS 902, 905 | A | A | A | - | A | - | A | A | A |
| Shell IRUS Fluid DU 46 | F | A | A | - | - | - | - | - | - |
| Shell Naturelle HF-E | F | A | A | F | X | F14 | A | A | A |
| Shell Pella-A | A | A | A | A 15 | X | - | A | A | A |
| Shell Tellus | F | A | A | A 14 | X | A | A | A | A |
| Shell Tellus TD 46 | A | A | A | A | A | X | A | A | A |
| Shell Thermia Oil C | A | A | A | A 14 | X | A | A | A | A |
| Shell Turbo R | X | F | F | A 15 | X | X | A | A | A |
| SHF 220, 300, 450 | X | X | A | X | X | X | A | A | A |
| Silicate Esters | A | F | F | A 15 | X | - | A | A | A |
| Silicone Oils | A | A | A | - | - | - | A | A | A |
| Silicone Sealants | X | X | X | X | X | - | A | A | A |
| Skydrol 500B-4, LD-4 | X | X | X | X | A, 7 | F | A | A | A |
| Soap Solutions | E | F | F | F 15 | A | A | A | A | A |
| Soda Ash, Sodium Carbonate | A | A | A | A 15 | A | - | A | F | A |
| Sodium Bisulfate | F | X | X | A 15 | A | - | F | A | F |
| Sodium Chloride | A | F | F | A 15 | A | - | X | F | A |
| Sodium Hydroxide | A | X | X | A 15 | A | - | A | X | A |
| Sodium Hypochlorite | A | X | X | X | A | X | X | X | X |
| Sodium Nitrate | A | F | F | A 15 | A | A | A | F | A |
| Sodium Peroxide | F | X | X | X | A | X | X | X | A |
| Sodium Silicate | A | A | A | A 15 | A | - | A | A | A |
| Sodium Sulfate | A | A | A | A 15 | A | - | A | A | A |
| Soybean Oil | F | A | A | A 15 | X | - | A | A | A |
| SSR Coolant | X | X | X | A 15 | X | X | A | A | A |
| Steam | X | X | X | X | X | - | F | A | A |
| Stoddard Solvent | 8 | 8 | 8 | 8 | X | 8 | A | A | A |
| Sulfur Chloride | X | X | X | F | X | - | X | X | X |
| Sulfur Dioxide | X | X | X | X | F | - | X | F | F |
| Sulfur Trioxide | X | X | X | F | F | - | X | X | X |
| Sulfuric Acid (0% to 30% room temperature) | F, 6 | F, 6 | F, 6 | X | F, 6 | - | 6 | X | 6 |
| Summa-20, Rotor, Recip | X | X | X | F | X | - | A | A | A |
| Summit DSL-32,68,100,125 | X | X | X | F | X | - | A | A | A |
| Sun Minesafe, Sun Safe | X | F | F | F | X | - | A | A | A |
| Sundex 8125 | X | F | F | - | X | - | A | A | A |
| Suniso 3GS | A | A | A | A 14 | X | A | A | A | A |
| Sun-Vis 722 | X | F | F | - | X | - | A | A | A |
| Super Hydraulic Oil 100, 150, 220 | A | A | A | A 14 | X | A | A | A | A |
| SUVA MP 39, 52, 66 | X | X | X | X | X | X | A | A | A |
| SYNCON Oil | X | X | X | X | X | - | A | A | A |
| Syndale 2820 | X | F | F | - | - | - | A | A | A |
| Synesstic 32,68,100 | X | X | X | X | X | X | A | A | A |
| Syn-Flo 70,90 | X | X | X | X | X | - | A | A | A |
| SYN-O-AD 8478 | X | X | X | X | A, 7 | F | A | A | A |
| T | | | | | | | | | |
| Tannic Acid | F | A | A | F | A | X | X | F | X |
| Tar | F | F | F | F | X | - | X | F | A |
| Tellus (Shell) | F | A | A | A 14 | X | F | A | A | A |
| Texaco 760 Hydraulfluid | - | - | - | - | X | - | A | A | A |
| Texaco 766, 763 (200 - 300) | - | - | - | - | A | - | F | F | A |
| Texaco A-Z Oil | A | A | A | F 14 | X | A | A | A | A |
| Texaco Spindura Oil 22 | F | F | F | F 14 | X | A | A | A | A |
| Texaco Way Lubricant 68 | A | A | A | A 14 | X | A | A | A | A |

| Medium | I | II | III | IV | V | VI | STEEL | BRASS | SS |
|-----------------------------|---|-------|-----|------|------|----|-------|-------|----|
| Thanol-R-650-X | X | F | F | - | X | - | A | A | A |
| Thermanol 60 | X | X | X | X | X | - | A | A | A |
| Toluene, Toluol | X | X | X | X | X | - | A | A | A |
| Transmission Oil | A | A | A | A 14 | X | A | A | A | A |
| Tribol 1440 | X | X | X | X | X | F | A | A | A |
| Trichloroethylene | X | X | X | F | X | - | X | A | A |
| Trim-Sol | F | A | A | F | X | - | A | A | A |
| Turbinol 50, 1122, 1223 | X | X | X | X | A, 7 | - | A | A | A |
| Turpentine | X | X | X | F | X | - | A | A | A |
| U | | | | | | | | | |
| Ucon Hydrolubes | F | A | A | A | A | F | A | A | A |
| UltraChem 215,230,501,751 | X | X | X | A 15 | X | - | A | A | A |
| Univis J26 | A | A | A | A 14 | X | A | A | A | A |
| Unleaded Gasoline | | See 9 | | | | - | A | A | A |
| Unocal 66/3 Mineral Spirits | 8 | 8 | 8 | 8 | X | - | A | A | A |
| Urea | F | F | F | A 15 | F | - | F | - | F |
| Urethane Formulations | A | A | A | A 15 | - | - | A | A | A |
| V | | | | | | | | | |
| Van Straaten 902 | A | A | A | A 15 | X | - | A | A | A |
| Varnish | X | X | X | F | X | - | F | F | A |
| Varsol | 8 | F | F | 8 | X | - | A | A | A |
| Versilube F44, F55 | - | A | A | A 15 | - | - | A | A | A |
| Vinegar | X | X | X | A 15 | A | - | F | X | A |
| Vital 29, 4300, 5230, 5310 | X | X | X | X | X | - | A | A | A |
| Volt Esso 35 | A | A | A | A 15 | X | - | A | A | A |
| W | | | | | | | | | |
| Water | A | A | A | A | A | A | F | A | A |
| Water / Glycols | A | A | A | A | A | F | A | F | A |
| X | | | | | | | | | |
| Xylene, Xylol | X | X | X | X | X | - | A | A | A |
| Z | | | | | | | | | |
| Zerol 150 | A | A | A | A 14 | X | A | A | A | A |
| Zinc Chloride | A | A | A | X | A | - | X | X | F |
| Zinc Sulfate | A | A | A | X | A | - | X | A | A |

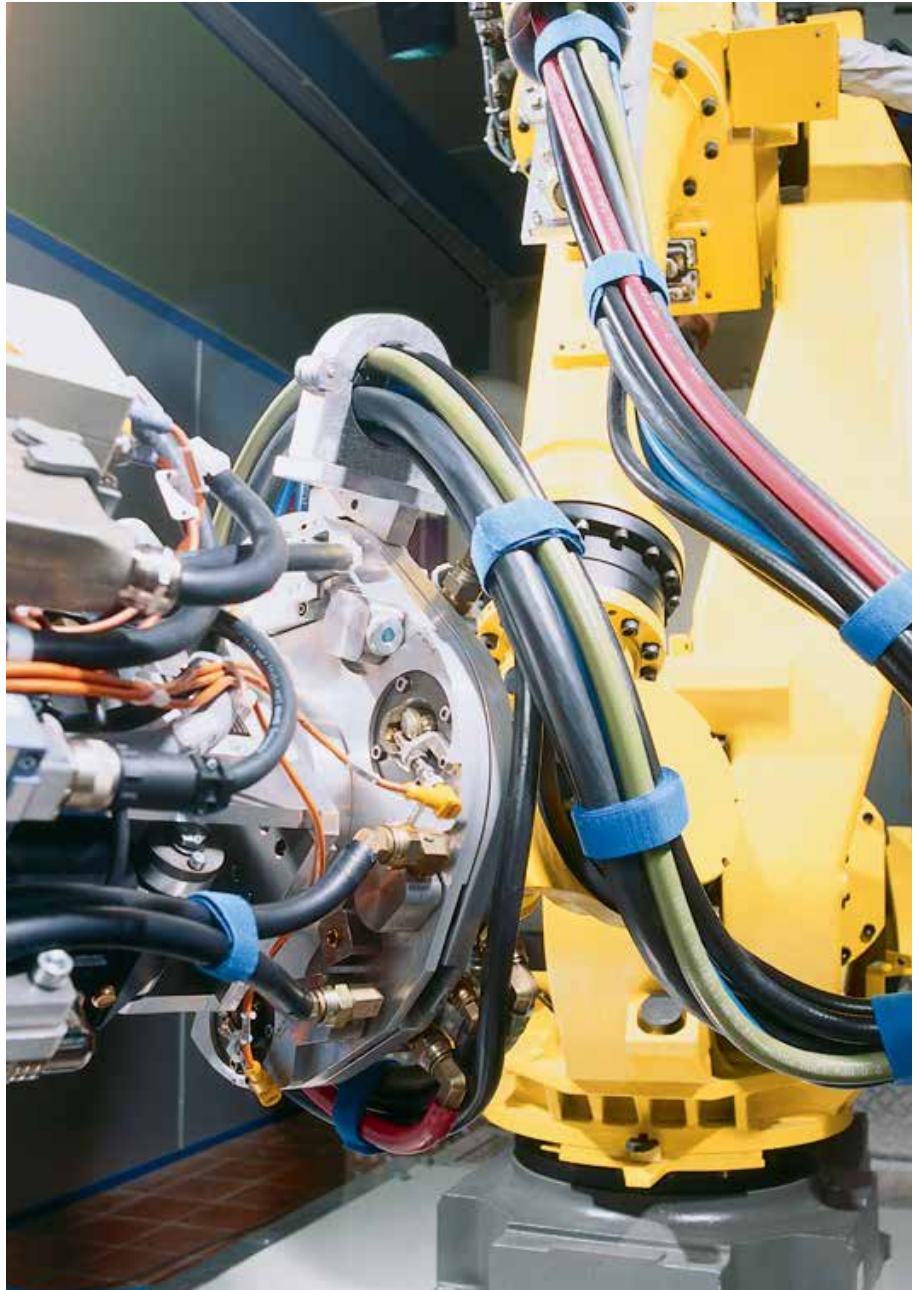

Hydraulic Hoses and Fittings

Low Pressure



ENGINEERING YOUR SUCCESS.

Push-Lok®

The self-grip hose system for low-pressure applications

Parker's Push-Lok hose line features the widest fluid compatibility, application and size range in the industry. The Push-Lok system is easy to use. No clamps or special tools are required during installation. And with Parker's exclusive color-code system, you can inventory, maintain and identify your hose needs easily and efficiently. The industry's most complete line of low-pressure hose and fittings, Push-Lok offers the range and versatility to meet all your instrumentation needs.

One fitting series for all hose types with a wide range of end-configurations

DIN, BSP, SAE, JIC and ORFS connections in

- brass
- steel
- stainless steel



Wide range of hose types

7 x rubber

- 801PLUS** for a variety of applications
- 801RH** for train vehicles
- 804** for high-temperature water/phosphate ester fluids
- 821FR** with fire-retardant hose cover
- 836, 846** for high oil temperatures
- 837BM** for a variety of applications including automotive

2 x thermoplastic

- 830M** for a variety of applications including automotive
- 838M** for non-conductive applications

1 x hybrid

- 837PU-PLUS** for a variety of high demanding applications including automotive

Wide range of applications



The outstanding properties

- Easy assembly and organisation with Parker's exclusive color-code system
- Push-Lok assemblies can be made in seconds, saving valuable time and cost
- The unique seal of Push-Lok ensures reliable, durable, leak-free service
- High functional safety with a design factor of 4
- Wide range of hose and fittings for a wide range of applications

Exclusive color-code system

6 different colours

In applications where a number of hose lines carry different media, Push-Lok colors reduce timely "tracing" of lines, preventing disconnection of wrong line and unnecessary, downtime.

Using color-coded Push-Lok hose is an excellent way to:

- Enhance product appearance
- Improve inventory control
- Identify industrial drop lines
- Easy control of maintenance intervals
- Simple stock planning in different departments



Hose construction and hose-fitting connection

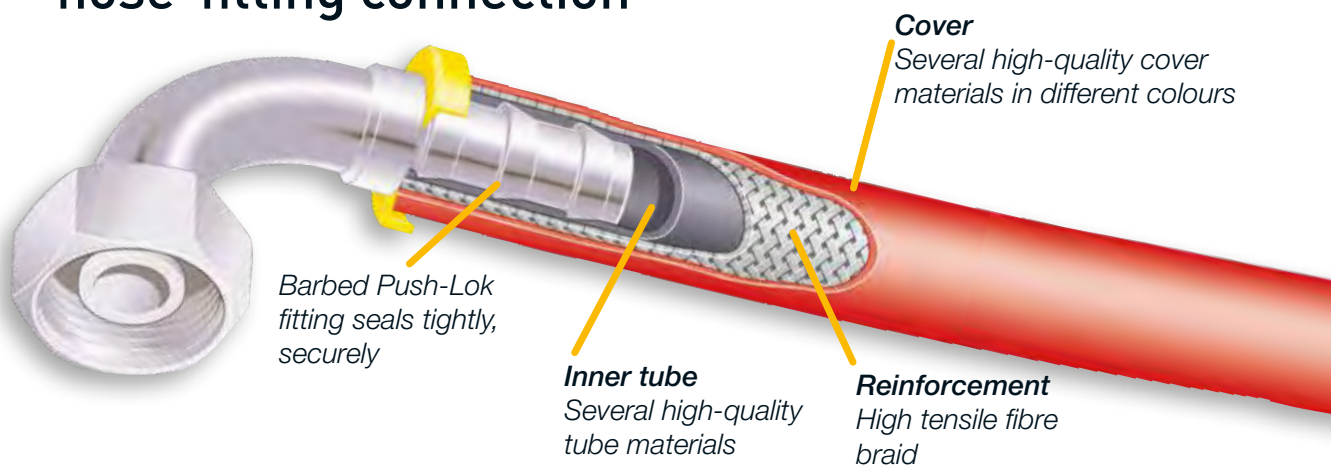

B1-3

Low Pressure Push-Lok

| Hoses | | Page |
|----------------|------------------|--------|
| 801Plus | Multipurpose | B1a-1 |
| 801RH | Railway | B1a-2 |
| 804 | Phosphate Ester | B1a-3 |
| 821FR | Fire retardant | B1a-4 |
| 830M | Multipurpose | B1a-5 |
| 836 | High temperature | B1a-6 |
| 837BM | Multipurpose | B1a-7 |
| 837PU | Multipurpose | B1a-8 |
| 838M | Non-conductive | B1a-9 |
| 846 | High temperature | B1a-10 |

Index

| | |
|--------------------------------------|---------|
| Fittings Series | 82 |
| Chapter | B1b |
| DIN – Metric | 1 – 7 |
| BSP | 8 – 10 |
| SAE | 11 – 14 |
| ORFS | 15 |
| Others | 16 – 18 |
| Assembly Instructions / Tools | 19 |

Parker Hannifin assumes no liability for typographical errors or other errors



Standard



High temperature



Railway



Transportation



Fire retardant



Refrigeration



801PLUS

Push-Lok Plus

For a variety of applications

Primary Applications

All Markets: For low pressure applications
Paper and Pulp: For water / air applications

Restrictions

Not permitted for use in air brake systems, high dynamic pulsation systems and with dry air.
Not recommended for fuels.

Construction

Inner tube: Nitrile (NBR)
Reinforcement: High-tensile fibre braid
Cover: High performance synthetic rubber in different colours

Temperature Range -40 °C up to +100 °C

Exception: Air max. +70 °C
Water max. +85 °C



- Global availability and performance
- Very flexible
- Available in 6 colours
- Available up to size -16
- Nitrile (NBR) inner tube – extended fluid compatibility
- Improved oil compatibility

Hose

Recommended Fluids

Air, water, water-oil emulsions, water-glycol and mineral based hydraulic respectively lubricating oils.
Consult the chemical compatibility section pages **Ab-26 to Ab-34** for more detailed information.

Fitting Series



| Part Number | Hose I.D. | | | | Hose O.D. mm | Pressure Rating | | | | Vacuum* kPa | min. bend radius mm | weight kg |
|-------------------|-----------|------|------|------|-----------------|------------------------------|-----|----------------------------|------|----------------|------------------------|--------------|
| | DN | Inch | Size | mm | | max. working pressure MPa | psi | min. burst pressure MPa | psi | | | |
| | | | | | | | | | | | | |
| 801PLUS-4-XXX-RL | 6 | 1/4 | -4 | 6.4 | 12.1 | 2.4 | 350 | 9.7 | 1400 | 95 | 65 | 0.13 |
| 801PLUS-6-XXX-RL | 10 | 3/8 | -6 | 9.5 | 15.6 | 2.4 | 350 | 9.7 | 1400 | 95 | 75 | 0.16 |
| 801PLUS-8-XXX-RL | 12 | 1/2 | -8 | 12.7 | 19.4 | 2.1 | 300 | 8.4 | 1200 | 95 | 125 | 0.27 |
| 801PLUS-10-XXX-RL | 16 | 5/8 | -10 | 15.9 | 23.1 | 2.1 | 300 | 8.4 | 1200 | 51 | 150 | 0.28 |
| 801PLUS-12-XXX-RL | 19 | 3/4 | -12 | 19.1 | 25.7 | 2.1 | 300 | 8.4 | 1200 | 51 | 180 | 0.36 |
| 801PLUS-16-XXX-RL | 25 | 1 | -16 | 25.4 | 33.0 | 1.4 | 200 | 5.6 | 800 | 51 | 250 | 0.55 |

* The vacuum values listed in the table are vacuum pressure values in kPa. For an absolute value subtract the table value from 101 kPa

Note: When ordering, please replace in the part number XXX with the relevant colour code. Example: 801PLUS-4-BLU-RL

For 801PLUS in yellow (YEL) only, please consider the part-number without PLUS. Example: 801-4-YEL-RL

Colour codes

BLK = black
BLU = blue
RED = red
GRN = green
GRA = grey
YEL = yellow



RL = only available on reels

Hose layline example

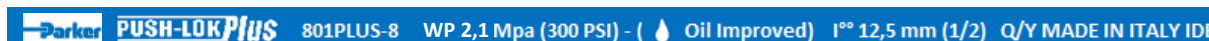

801 Hose

- 801PLUS-4
- 801PLUS-6
- 801PLUS-8
- 801PLUS-10
- 801PLUS-12
- 801PLUS-16



801RH

Push-Lok

Fire retardant cover



Primary Applications

For low pressure railway applications

Restrictions

Not permitted for use in air brake systems.
Not suitable for high dynamic pulsation systems.
Not recommended for fuels (petrol, diesel etc.).
Not recommended for mineral based hydraulic and lubricating oils.

Construction

Tube: Synthetic rubber
Reinforcement: High-tensile fibre braid
Cover: Fire retardant synthetic rubber

- Very flexible
- Railway approved:
 - European Standard EN45545 HL2 for R22 (internal) and R23 (external)

Recommended Fluids

Air, water, water-oil-emulsions and water-glycol-emulsions.
Consult the chemical compatibility section on pages **Ab-26** to **Ab-34** for more detailed information.

Temperature Range -40 °C up to +100 °C

Exception: Air max. +70 °C
Water max. +85 °C

Fitting Series



| Part Number | Hose I.D. | | | | Hose O.D. mm | Pressure Rating | | | | Vacuum* | min. bend radius mm | weight kg |
|----------------|-----------|------|------|-----|-----------------|------------------------------|-----|----------------------------|------|---------|------------------------|--------------|
| | DN | Inch | Size | mm | | max. working pressure MPa | psi | min. burst pressure MPa | psi | | | |
| 801RH-4-BLK-RL | 6 | 1/4 | -4 | 6.4 | 12.7 | 2.4 | 350 | 9.7 | 1400 | 95 | 65 | 0.13 |
| 801RH-6-BLK-RL | 10 | 3/8 | -6 | 9.5 | 15.9 | 2.4 | 350 | 9.7 | 1400 | 95 | 75 | 0.16 |

* The vacuum values listed in the table are vacuum pressure values in kPa. For an absolute value subtract the table value from 101 kPa

Colour code

BLK = black



The hose is available in black only

RL = only available on reels

Hose layline example

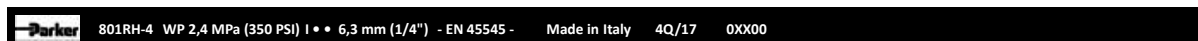

B1a-2

Catalogue 4400/UK

804

Push-Lok

For high temperature water and phosphate ester fluid

Primary Applications

Injection Moulding: For special tempering circuits.

Restrictions

Not permitted for use in air brake systems and high dynamic pulsation systems.

Do not allow tube to contact any petroleum based fluids.

Construction

Inner tube: EPDM synthetic rubber

Reinforcement: High-tensile fibre braid

Cover: EPDM synthetic rubber , black

Temperature Range -40 °C up to +80 °C

Exception: Air max. +70 °C

Water max. +93 °C



- For hot water up to +93 °C
- For phosphate ester fluids

Hose

Recommended Fluids

Phosphate ester based hydraulic fluids, water, water glycol emulsions, air. Use liquid soap as lubricant.

Consult the chemical compatibility section pages

Ab-26 to Ab-34 for more detailed information.

Fitting Series



| Part Number | Hose I.D. | | | | Hose O.D. mm | Pressure Rating | | | | Vacuum* kPa | min. bend radius mm | weight kg |
|-------------|-----------|------|------|------|-----------------|------------------------------|-----|----------------------------|-----|----------------|------------------------|--------------|
| | DN | Inch | Size | mm | | max. working pressure MPa | psi | min. burst pressure MPa | psi | | | |
| 804-4-RL | 6 | 1/4 | -4 | 6.4 | 12.7 | 1.0 | 150 | 4.0 | 600 | 51 | 65 | 0.13 |
| 804-6-RL | 10 | 3/8 | -6 | 9.5 | 15.9 | 1.0 | 150 | 4.0 | 600 | 51 | 75 | 0.16 |
| 804-8-RL | 12 | 1/2 | -8 | 12.7 | 19.8 | 1.0 | 150 | 4.0 | 600 | 51 | 130 | 0.27 |
| 804-10-RL | 16 | 5/8 | -10 | 15.9 | 23.0 | 1.0 | 150 | 4.0 | 600 | 51 | 150 | 0.28 |
| 804-12-RL | 19 | 3/4 | -12 | 19.1 | 26.2 | 1.0 | 150 | 4.0 | 600 | 51 | 180 | 0.36 |

RL = only available on reels

Cover color

Hose layline example

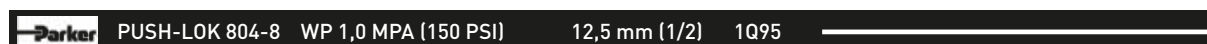

B1a-3

Catalogue 4400/UK

Low Pressure
Push-Lok – Fire retardant

Push-Lok Hose
821FR

821FR

Push-Lok

With fire retardant hose cover



- Fire retardant hose cover
- Very flexible
- For high level air temperatures

Primary Applications

All Markets: For a variety of applications

Restrictions

Not permitted for use in air brake systems and high dynamic pulsation systems.

Not recommended for fuels.

Construction

Inner tube: PKR synthetic rubber

Reinforcement: High-tensile fibre braid

Cover: A fire retardant special fiber outer cover in different colours

Recommended Fluids

Mineral based hydraulic and lubricating oils, coolant, antifreeze, air, water and water-oil emulsions.

Consult the chemical compatibility section pages **Ab-26 to Ab-34** for more detailed information.

Temperature Range -40 °C up to +100 °C

Exception: Air max. +100 °C

Water max. +85 °C

Fitting Series



| Part Number | Hose I.D. | | | | Hose O.D. mm | Pressure Rating | | | | Vacuum* kPa | min. bend radius mm | weight kg |
|-----------------|-----------|------|------|------|-----------------|------------------------------|-----|----------------------------|------|----------------|------------------------|--------------|
| | DN | Inch | Size | mm | | max. working pressure MPa | psi | min. burst pressure MPa | psi | | | |
| 821FR-4-XXX-RL | 6 | 1/4 | -4 | 6.4 | 12.7 | 2.4 | 350 | 9.6 | 1400 | 95 | 65 | 0.12 |
| 821FR-6-XXX-RL | 10 | 3/8 | -6 | 9.5 | 15.9 | 2.1 | 300 | 8.4 | 1200 | 95 | 75 | 0.16 |
| 821FR-8-XXX-RL | 12 | 1/2 | -8 | 12.7 | 19.8 | 2.1 | 300 | 8.4 | 1200 | 95 | 130 | 0.18 |
| 821FR-12-XXX-RL | 19 | 3/4 | -12 | 19.1 | 26.2 | 1.7 | 250 | 6.8 | 1000 | 95 | 180 | 0.33 |

* The vacuum values listed in the table are vacuum pressure values in kPa. For an absolute value subtract the table value from 101 kPa

Note: When ordering, please replace in the part number XXX with the relevant colour code. Example: 821FR-4-GRN-RL

Colour codes

BLK = black

BLU = blue

GRN = green



RL = only available on reels

Hose layline example

PARKER PUSH-LOK 821FR-8 WP 2,0 MPa (300 PSI) 12,5 mm [1/2] 11-4Q85



B1a-4

Catalogue 4400/UK

830M

Push-Lok

For a variety of applications including automotive

Primary Applications

All Markets: For a variety of applications

Robot and Automotive market:

For hose bundle systems

Restrictions

Not permitted for use in air brake systems and high dynamic pulsation systems.

Not recommended for fuels.

Construction

Inner tube: Polyurethane material

Reinforcement: High-tensile fibre braid

Cover: High performance polyurethane material in different colours



- Chemical resistant for a wide range of fluids
- High abrasion resistance
- Free of wetting disturbing substances (LABS free)
- Small OD and bend radii
- Excellent UV and ozone resistance

Hose

Recommended Fluids

Mineral based hydraulic and lubricating oils, coolant, antifreeze, air, water and water-oil emulsions.

Consult the chemical compatibility section pages **Ab-26 to Ab-34** for more detailed information.

Temperature Range -40 °C up to +80 °C

Fitting Series



| Part Number | Hose I.D. | | | | Hose O.D. mm | Pressure Rating | | | | Vacuum* | min. bend radius mm | weight kg |
|----------------|-----------|------|------|------|-----------------|------------------------------|-----|----------------------------|-----|---------|------------------------|--------------|
| | DN | Inch | Size | mm | | max. working pressure MPa | psi | min. burst pressure MPa | psi | | | |
| 830M-4-XXX-RL | 6 | 1/4 | -4 | 6.4 | 10.7 | 1.6 | 232 | 6.4 | 928 | 10 | 30 | 0.08 |
| 830M-6-XXX-RL | 10 | 3/8 | -6 | 9.5 | 14.9 | 1.6 | 232 | 6.4 | 928 | 10 | 50 | 0.13 |
| 830M-8-XXX-RL | 12 | 1/2 | -8 | 12.7 | 19.1 | 1.6 | 232 | 6.4 | 928 | 10 | 70 | 0.20 |
| 830M-10-XXX-RL | 16 | 5/8 | -10 | 15.9 | 23.0 | 1.6 | 232 | 6.4 | 928 | 10 | 75 | 0.26 |
| 830M-12-XXX-RL | 19 | 3/4 | -12 | 19.1 | 26.0 | 1.6 | 232 | 6.4 | 928 | 10 | 110 | 0.31 |

* The vacuum values listed in the table are vacuum pressure values in kPa. For an absolute value subtract the table value from 101 kPa
Note: When ordering, please replace in the part number XXX with the relevant colour code. Example: 830M-4-GRN-RL

Colour codes

BLK = black
BLU = blue
RED = red
GRN = green
TRA = transparent, size -6 & -8
RL = only available on reels



Hose layline example



836

Push-Lok

For high oil temperatures

Primary Applications

All Markets: Special high temperature applications

Type Approvals

Details please find on pages **Ab-16** to **Ab-19**

Restrictions

Not permitted for use in air brake systems and high dynamic pulsation systems.

Not recommended for fuels.

Construction

Inner tube: PKR synthetic rubber
Reinforcement: High-tensile fibre braid
Cover: MSHA approved black or blue
PKR synthetic rubber

Temperature Range -48 °C up to +150 °C

Exception: Air max. +100 °C

Water max. +85 °C



- Max. oil temperature up to +150 °C
- MSHA approved

Recommended Fluids

Mineral based hydraulic and lubricating oils, coolant, antifreeze, air, water and water-oil emulsions.

Consult the chemical compatibility section pages **Ab-26** to **Ab-34** for more detailed information.

Fitting Series



| Part Number | Hose I.D. | | | | Hose O.D. mm | Pressure Rating | | | | Vacuum* kPa | min. bend radius mm | weight kg |
|---------------|-----------|------|------|------|-----------------|------------------------------|-----|----------------------------|------|----------------|------------------------|--------------|
| | DN | Inch | Size | mm | | max. working pressure MPa | psi | min. burst pressure MPa | psi | | | |
| 836-4-XXX-RL | 6 | 1/4 | -4 | 6.4 | 12.7 | 2.8 | 400 | 11.2 | 1600 | 95 | 65 | 0.13 |
| 836-6-XXX-RL | 10 | 3/8 | -6 | 9.5 | 15.9 | 2.8 | 400 | 11.2 | 1600 | 95 | 75 | 0.16 |
| 836-8-XXX-RL | 12 | 1/2 | -8 | 12.7 | 19.8 | 2.8 | 400 | 11.2 | 1600 | 95 | 100 | 0.27 |
| 836-10-XXX-RL | 16 | 5/8 | -10 | 15.9 | 23.0 | 2.4 | 350 | 9.6 | 1400 | 61 | 125 | 0.28 |
| 836-12-XXX-RL | 19 | 3/4 | -12 | 19.1 | 26.2 | 2.1 | 300 | 8.4 | 1200 | 61 | 150 | 0.36 |

* The vacuum values listed in the table are vacuum pressure values in kPa. For an absolute value subtract the table value from 101 kPa
Note: When ordering, please replace in the part number XXX with the relevant colour code. Example: 836-4-BLK-RL

Colour codes

BLK = black
BLU = blue



RL = only available on reels

Hose layline example

PARKER HI-TEMP PUSH-LOK 836-8 WP 1,7 MPa [250 PSI] MSHA IC-40/22 | • • 12,5 mm (1/2)



B1a-6

Catalogue 4400/UK

837BM

Push-Lok

For a variety of applications including automotive

Primary Applications

All Markets: For a variety of applications

Automotive: For water / air applications

Restrictions

Not permitted for use in air brake systems and high dynamic pulsation systems.

Not recommended for fuels, mineral based hydraulic and lubricating oils and water-oil-emulsion.

Construction

Inner tube: Synthetic rubber

Reinforcement: High-tensile fibre braid

Cover: High performance synthetic rubber in different colours

Temperature Range -40 °C up to +100 °C

Exception: Air max. +70 °C

Water max. +85 °C



- High level of hose flexibility
- High abrasion resistance
- Free from wetting disturbing substances (LABS free)
- Low push-in forces

Hose

Recommended Fluids

Air, dry air, water and water-glycol-emulsions.

Consult the chemical compatibility section pages

Ab-26 to Ab-34 for more detailed information.

Fitting Series



| Part Number | Hose I.D. | | | | Hose O.D. mm | Pressure Rating | | | | Vacuum* kPa | min. bend radius mm | weight kg |
|-----------------|-----------|------|------|------|-----------------|------------------------------|-----|----------------------------|-----|----------------|------------------------|--------------|
| | DN | Inch | Size | mm | | max. working pressure MPa | psi | min. burst pressure MPa | psi | | | |
| | | | | | | | | | | | | |
| 837BM-4-XXX-RL | 6 | 1/4 | -4 | 6.4 | 12.1 | 1.6 | 235 | 6.4 | 940 | 95 | 65 | 0.13 |
| 837BM-6-XXX-RL | 10 | 3/8 | -6 | 9.5 | 15.6 | 1.6 | 235 | 6.4 | 940 | 95 | 75 | 0.16 |
| 837BM-8-XXX-RL | 12 | 1/2 | -8 | 12.7 | 19.4 | 1.6 | 235 | 6.4 | 940 | 95 | 125 | 0.27 |
| 837BM-10-XXX-RL | 16 | 5/8 | -10 | 15.9 | 23.1 | 1.6 | 235 | 6.4 | 940 | 51 | 150 | 0.28 |
| 837BM-12-XXX-RL | 19 | 3/4 | -12 | 19.1 | 25.7 | 1.6 | 235 | 6.4 | 940 | 51 | 180 | 0.36 |
| 837BM-16-XXX-RL | 25 | 1 | -16 | 25.4 | 33.0 | 1.6 | 235 | 6.4 | 940 | 51 | 250 | 0.55 |

* The vacuum values listed in the table are vacuum pressure values in kPa. For an absolute value subtract the table value from 101 kPa

Note: When ordering, please replace in the part number XXX with the relevant colour code. Example: 837BM-4-GRN-RL

Colour codes

BLK = black
BLU = blue
RED = red
GRN = green
GRA = grey



RL = only available on reels

Hose layline example

PARKER PUSH-LOK 837BM-10 WP 1,6 MPa [235 PSI] | • • 16 mm [5/8]



Low Pressure
Push-Lok – Multipurpose

Push-Lok Hose
837PU-Plus

837PU-Plus

Hybrid Push-Lok

For a variety of high demanding applications

Primary Applications

All Markets: For high demand applications
For energy chain systems

Robot and Automotive market:
For hose bundle systems

Restrictions

Not permitted for use in air brake systems and high dynamic pulsation systems.
Not recommended for fuels, mineral based hydraulic and lubricating oils and water-oil-emulsion.

Construction

Inner tube: Synthetic rubber
Reinforcement: High-tensile fibre braid
Cover: High performance polyurethane material in different colours

Temperature Range -40 °C up to +100 °C

Exception: Air max. +70 °C
Water max. +85 °C



- High level of hose flexibility
- High abrasion resistance
- High torsion resistance
- Free from wetting disturbing substances (LABS free)
- Low push-in forces

Recommended Fluids

Air, dry air, water and water-glycol-emulsions.
Consult the chemical compatibility section pages **Ab-26 to Ab-34** for more detailed information.

Fitting Series



| Part Number | Hose I.D. | | | | Hose O.D. mm | Pressure Rating | | | | Vacuum* kPa | min. bend radius mm | weight kg |
|-----------------|-----------|------|------|------|-----------------|------------------------------|-----|----------------------------|-----|----------------|------------------------|--------------|
| | DN | Inch | Size | mm | | max. working pressure MPa | psi | min. burst pressure MPa | psi | | | |
| 837PU-4-XXX-RL | 6 | 1/4 | -4 | 6.4 | 12.3 | 1.6 | 235 | 6.4 | 940 | 95 | 30 | 0.11 |
| 837PU-6-XXX-RL | 10 | 3/8 | -6 | 9.5 | 15.5 | 1.6 | 235 | 6.4 | 940 | 95 | 50 | 0.15 |
| 837PU-8-XXX-RL | 12 | 1/2 | -8 | 12.7 | 19.5 | 1.6 | 235 | 6.4 | 940 | 95 | 70 | 0.26 |
| 837PU-10-XXX-RL | 16 | 5/8 | -10 | 15.9 | 22.6 | 1.6 | 235 | 6.4 | 940 | 51 | 90 | 0.27 |
| 837PU-12-XXX-RL | 19 | 3/4 | -12 | 19.1 | 26.2 | 1.6 | 235 | 6.4 | 940 | 51 | 110 | 0.33 |
| 837PU-16-XXX-RL | 25 | 1 | -16 | 25.4 | 32.8 | 1.6 | 235 | 6.4 | 940 | 51 | 180 | 0.52 |

* The vacuum values listed in the table are vacuum pressure values in kPa. For an absolute value subtract the table value from 101 kPa
Note: When ordering, please replace in the part number XXX with the relevant colour code. Example: 837PU-4-GRN-RL

Colour codes

BLK = black
BLU = blue
RED = red
GRN = green
GRA = grey



RL = only available on reels

Hose layline example

PARKER PUSH-LOK 837PU-Plus-8 WP 1,6 MPa (235 PSI) 1 ° 12,5 mm (1/2)



B1a-8

Catalogue 4400/UK

838M

Push-Lok

For non-conductive applications

Primary Applications

Special Market: For special electrical requirements,
e.g. cooling lines with deionized water

Restrictions

Not permitted for use in air brake systems and high dynamic pulsation systems.
Not recommended for fuels.

Construction

Inner tube: Polyurethane material
Reinforcement: High-tensile fibre braid
Cover: Orange colored polyurethane material

Temperature Range -40 °C up to +80 °C



- Non conductive hose
- High level of hose flexibility
- High abrasion resistance
- Free of wetting disturbing substances (LABS free)
- Small OD and bend radii
- Excellent UV and ozone resistance

Hose

Recommended Fluids

Mineral based hydraulic and lubricating oils, coolant, antifreeze, air, water, water-oil emulsions.
Consult the chemical compatibility section pages **Ab-26 to Ab-34** for more detailed information.

Fitting Series



| Part Number | Hose I.D. | | | | Hose O.D. mm | Pressure Rating | | | | Vacuum* kPa | min. bend radius mm | weight kg |
|-------------|-----------|------|------|------|-----------------|------------------------------|-----|----------------------------|-----|----------------|------------------------|--------------|
| | DN | Inch | Size | mm | | max. working pressure MPa | psi | min. burst pressure MPa | psi | | | |
| 838M-4-RL | 6 | 1/4 | -4 | 6.4 | 11.2 | 1.6 | 232 | 6.4 | 928 | 10 | 30 | 0.08 |
| 838M-6-RL | 10 | 3/8 | -6 | 9.5 | 15.0 | 1.6 | 232 | 6.4 | 928 | 10 | 50 | 0.13 |
| 838M-8-RL | 12 | 1/2 | -8 | 12.7 | 19.1 | 1.6 | 232 | 6.4 | 928 | 10 | 70 | 0.20 |
| 838M-10-RL | 16 | 5/8 | -10 | 15.9 | 23.0 | 1.6 | 232 | 6.4 | 928 | 10 | 75 | 0.26 |
| 838M-12-RL | 19 | 3/4 | -12 | 19.1 | 26.0 | 1.6 | 232 | 6.4 | 928 | 10 | 110 | 0.31 |

* The vacuum values listed in the table are vacuum pressure values in kPa. For an absolute value subtract the table value from 101 kPa
RL = only available on reels

Cover color

Hose layline example



846

Push-Lok

For high oil temperatures



- For high temperature applications up to + 150 °C
- MSHA approved
- Lower fitting insertion force

Primary Applications

All markets: Special high temperature applications

Restrictions

Not permitted for use in air brake systems and high dynamic pulsation systems.
Not recommended for fuels.

Construction

Inner tube: PKR synthetic rubber
Reinforcement: High-tensile fibre braid
Cover: MSHA approved black or blue
PKR synthetic rubber

Recommended Fluids

Mineral based hydraulic and lubricating oils, coolant, antifreeze, air, water and water-oil emulsions.
Consult the chemical compatibility section pages **Ab-26** to **Ab-34** for more detailed information.

Temperature Range -48 °C up to +150 °C

Exception: Air max. +100 °C
Water max. +85 °C

Fitting Series



| Part Number | Hose I.D. | | | | Hose O.D. mm | Pressure Rating | | | | Vacuum* kPa | min. bend radius mm | weight kg |
|-----------------|-----------|------|------|------|-----------------|------------------------------|-----|----------------------------|-----|----------------|------------------------|--------------|
| | DN | Inch | Size | mm | | max. working pressure MPa | psi | min. burst pressure MPa | psi | | | |
| 846-4-XXX-RL | 6 | 1/4 | -4 | 6.4 | 12.6 | 1.6 | 230 | 6.4 | 930 | 95 | 65 | 0.13 |
| 846-6-XXX-RL | 10 | 3/8 | -6 | 9.5 | 15.8 | 1.6 | 230 | 6.4 | 930 | 95 | 75 | 0.19 |
| 846-8-XXX-RL | 12 | 1/2 | -8 | 12.7 | 19.8 | 1.6 | 230 | 6.4 | 930 | 95 | 130 | 0.27 |
| 846-10-XXX-RL | 16 | 5/8 | -10 | 15.9 | 23.1 | 1.6 | 230 | 6.4 | 930 | 51 | 150 | 0.31 |
| 846-12-XXX-RL** | 19 | 3/4 | -12 | 19.1 | 26.2 | 1.6 | 230 | 6.4 | 930 | 51 | 180 | 0.36 |

* The vacuum values listed in the table are vacuum pressure values in kPa. For an absolute value subtract the table value from 101 kPa
Note: When ordering, please replace in the part number XXX with the relevant colour code. Example: 846-4-GRN-RL

** under development

Colour codes

BLK = black
BLU = blue



RL = only available on reels

Hose layline example

HI-TEMP PUSH-LOK 846-8 WP 1,6 Mpa (230 PSI) MSHA IC 40/10 1° 12,5 mm (1/2) Q/Y MADE IN ITALY ID













B1a-10

Catalogue 4400/UK





DIN – Metric

Page B1b-1 – B1b-7

| | | | |
|-----------------------------------------------------------------------------------------------------------------------------------------------------------------------------------------------------------------------|----------------------------------------------------------------------------------------------------------------------------------------------------------------------------------------------------------------------------|-----------------------------------------------------------------------------------------------------------------------------------------------------------------------------------------------------------------------------|-------------------------------------------------------------------------------------------------------------------------------------------------------------------------------------------------------|
| <p>CA B1b-1</p>  <p>Female Metric 24° Light Series with O-Ring Swivel – Straight ISO 12151-2-SWS-L – DKOL</p> | <p>CE B1b-1</p>  <p>Female Metric 24° Light Series with O-Ring Swivel – 45° Elbow ISO 12151-2-SWE-L – DKOL 45°</p> | <p>CF B1b-2</p>  <p>Female Metric 24° Light Series with O-Ring Swivel – 90° Elbow ISO 12151-2-SWE-L – DKOL 90°</p> | <p>D0 B1b-2</p>  <p>Male Metric 24° Light Series – Rigid Straight ISO 12151-2-S-L – CEL</p> |
| <p>C3 B1b-3</p>  <p>Female Metric Light Series – Swivel Straight (Ball Nose for 24° or 60° Cone) DKL</p> | <p>C4 B1b-4</p>  <p>Female Metric Light Series – Swivel 45° Elbow (Ball Nose for 24° or 60° Cone) DKL 45°</p> | <p>C5 B1b-5</p>  <p>Female Metric Light Series – Swivel 90° Elbow (Ball Nose for 24° or 60° Cone) DKL 90°</p> | <p>49 B1b-6</p>  <p>Metric Banjo Straight DIN 7642</p> |
| <p>9B B1b-6</p>  <p>Female Metric Swivel Light Series Compact 45° Elbow (Ball Nose for 24° or 60° Cone)</p> | <p>9C B1b-7</p>  <p>Female Metric Swivel Light Series Compact 90° Elbow (Ball Nose for 24° or 60° Cone)</p> | | |



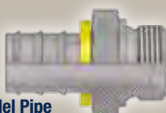

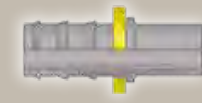

BSP

Page B1b-8 – B1b-10

| | | | |
|----------------------------------------------------------------------------------------------------------------------------------------------------------------------------------------------------|------------------------------------------------------------------------------------------------------------------------------------------------------------------------------------------------------------|-------------------------------------------------------------------------------------------------------------------------------------------------------------------------------------------------------------|-------------------------------------------------------------------------------------------------------------------------------------------------------------------------------------------------|
| <p>92 B1b-8</p>  <p>Female BSP Parallel Pipe Swivel – Straight (60° Cone) BS5200-A – DKR</p> | <p>B1 B1b-8</p>  <p>Female BSP Parallel Pipe Swivel 45° Elbow (60° Cone) BS 5200-D – DKR 45°</p> | <p>B2 B1b-9</p>  <p>Female BSP Parallel Pipe Swivel 90° Elbow (60° Cone) BS 5200-B – DKR 90°</p> | <p>D9 B1b-9</p>  <p>Male BSP Parallel Pipe Rigid – Straight (60° Cone) BS5200 – AGR</p> |
| <p>91 B1b-10</p>  <p>Male BSP Taper Pipe – Rigid Straight BS5200 – AGR-K</p> | <p>34 B1b-10</p>  <p>Inch Standpipe (Brass)</p> | | |

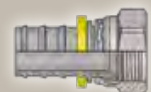
SAE

Page B1b-11 – B1b-14

| | | | |
|---------------------------------------------------------------------------------------------------------------------------------------------------------------------------------------|------------------------------------------------------------------------------------------------------------------------------------------------------------------------------------------------|----------------------------------------------------------------------------------------------------------------------------------------------------------------------------------------------|----------------------------------------------------------------------------------------------------------------------------------------------------------------------------------------|
| <p>01 B1b-11</p>  <p>Male NPTF Pipe Rigid – Straight SAE J476A / J516 – AGN</p> | <p>02 B1b-11</p>  <p>Female NPTF Pipe – Rigid Straight SAE J476A / J516</p> | <p>03 B1b-12</p>  <p>Male JIC 37° – Rigid Straight ISO12151-5-S – AGJ</p> | <p>06 B1b-12</p>  <p>Female JIC 37° – Swivel Straight ISO12151-5-SWS – DKJ</p> |
| <p>08 B1b-13</p>  <p>Female SAE 45° – Swivel Straight SAE J516</p> | <p>37 B1b-13</p>  <p>Female JIC 37° – Swivel 45° Elbow ISO 12151-5-SWE 45° – DKJ 45°</p> | <p>39 B1b-14</p>  <p>Female JIC 37° – Swivel 90° Elbow ISO 12151-5-SWES – DKJ 90°</p> | |

ORFS

Page B1b-15

JC

B1b-15

Female ORFS
Swivel – Straight
Short

ISO 12151-1 – SWSA SAE J516 – ORFS



Others

Page B1b-16 – B1b-18

FF

B1b-16

Metru-Lok Swivel Female



AF

B1b-16

Male BSP Parallel Pipe
Rigid – Straight
(with O-ring Seal)



82

B1b-17

Push-Lok® Union

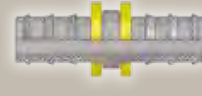

5C

B1b-17

60° Cone Swivel Female

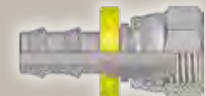

6C

B1b-18

60° Cone Swivel Female
45° Elbow



7C

B1b-18

60° Cone Swivel Female
90° Elbow



82 Series

Assembly Instructions

Page B1b-19

CA **Female Metric 24°
Light Series with O-Ring
Swivel – Straight**
ISO 12151-2-SWS-L – DKOL

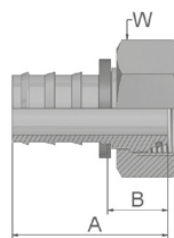

| Part Number | Hose I.D. | | | | Thread metric | Tube O.D. mm | A mm | B mm | W mm |
|--------------|-----------|------|------|------|------------------|--------------------|---------|---------|---------|
| | DN | Inch | Size | mm | | | | | |
| 3CA82-6-4 | 6 | 1/4 | -4 | 6.4 | M12x1.5 | 6 | 40 | 21 | 14 |
| 3CA82-6-4B | 6 | 1/4 | -4 | 6.4 | M12x1.5 | 6 | 40 | 21 | 14 |
| 3CA82-8-4 | 6 | 1/4 | -4 | 6.4 | M14x1.5 | 8 | 36 | 18 | 17 |
| 3CA82-8-4B | 6 | 1/4 | -4 | 6.4 | M14x1.5 | 8 | 36 | 18 | 17 |
| 3CA82-10-4 | 6 | 1/4 | -4 | 6.4 | M16x1.5 | 10 | 37 | 18 | 19 |
| 3CA82-10-6 | 10 | 3/8 | -6 | 9.5 | M16x1.5 | 10 | 40 | 18 | 19 |
| 3CA82-10-6B | 10 | 3/8 | -6 | 9.5 | M16x1.5 | 10 | 40 | 18 | 19 |
| 3CA82-12-6 | 10 | 3/8 | -6 | 9.5 | M18x1.5 | 12 | 40 | 17 | 22 |
| 3CA82-12-6B | 10 | 3/8 | -6 | 9.5 | M18x1.5 | 12 | 40 | 17 | 22 |
| 3CA82-15-8 | 12 | 1/2 | -8 | 12.7 | M22x1.5 | 15 | 45 | 18 | 27 |
| 3CA82-15-8B | 12 | 1/2 | -8 | 12.7 | M22x1.5 | 15 | 45 | 18 | 27 |
| 3CA82-15-10B | 16 | 5/8 | -10 | 15.9 | M22x1.5 | 15 | 61 | 24 | 27 |
| 3CA82-18-10 | 16 | 5/8 | -10 | 15.9 | M26x1.5 | 18 | 56 | 19 | 32 |
| 3CA82-22-12 | 19 | 3/4 | -12 | 19.1 | M30x2 | 22 | 58 | 21 | 36 |
| 3CA82-22-12B | 19 | 3/4 | -12 | 19.1 | M30x2 | 22 | 58 | 21 | 36 |

82 Series

Hose fittings are delivered with ozone resistant Nitrile (NBR) O-ring as a standard version. Working temperature from -40 °C up to +105 °C.
Hose fittings with special O-rings (Viton or EPDM) available on request. O-ring dimensions and part-numbers see in section Eb.

CE **Female Metric 24°
Light Series with O-Ring
Swivel – 45° Elbow**
ISO 12151-2-SWE -L – DKOL 45°

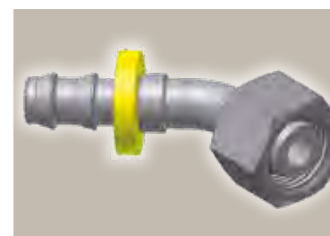
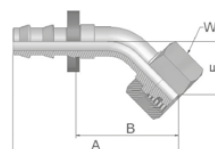

| Part Number | Hose I.D. | | | | Thread metric | Tube O.D. mm | A mm | B mm | E mm | W mm |
|-------------|-----------|------|------|------|------------------|--------------------|---------|---------|---------|---------|
| | DN | Inch | Size | mm | | | | | | |
| 3CE82-6-4 | 6 | 1/4 | -4 | 6.4 | M12x1.5 | 6 | 56 | 37 | 21 | 14 |
| 3CE82-8-4 | 6 | 1/4 | -4 | 6.4 | M14x1.5 | 8 | 51 | 32 | 16 | 17 |
| 3CE82-10-6 | 10 | 3/8 | -6 | 9.5 | M16x1.5 | 10 | 60 | 37 | 19 | 19 |
| 3CE82-12-6 | 10 | 3/8 | -6 | 9.5 | M18x1.5 | 12 | 60 | 37 | 19 | 22 |
| 3CE82-15-8 | 12 | 1/2 | -8 | 12.7 | M22x1.5 | 15 | 69 | 43 | 21 | 27 |
| 3CE82-18-10 | 16 | 5/8 | -10 | 15.9 | M26x1.5 | 18 | 83 | 46 | 23 | 32 |
| 3CE82-22-12 | 19 | 3/4 | -12 | 19.1 | M30x2 | 22 | 97 | 60 | 26 | 36 |

Hose fittings are delivered with ozone resistant Nitrile (NBR) O-ring as a standard version. Working temperature from -40 °C up to +105 °C.
Hose fittings with special O-rings (Viton or EPDM) available on request. O-ring dimensions and part-numbers see in section Eb.

Also available in stainless steel. Details can be found in CAT 4400.1/UK

Approved **fitting series** for hose types:

B: Brass

82 801Plus 801RH 804 821FR 830M 836 837BM 837PU 838M 846



CF Female Metric 24° Light Series with O-Ring Swivel – 90° Elbow

ISO 12151-2-SWE-L – DKOL 90°

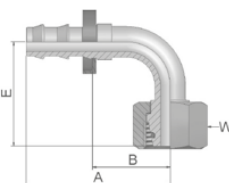

| Part Number | Hose I.D. | | | | Thread metric | Tube O.D. mm | A mm | B mm | E mm | W mm |
|-------------|-----------|------|------|------|------------------|--------------------|---------|---------|---------|---------|
| | DN | Inch | Size | mm | | | | | | |
| 3CF82-6-4 | 6 | 1/4 | -4 | 6.4 | M12x1.5 | 6 | 42 | 23 | 36 | 14 |
| 3CF82-8-4 | 6 | 1/4 | -4 | 6.4 | M14x1.5 | 8 | 41 | 23 | 29 | 17 |
| 3CF82-10-4 | 6 | 1/4 | -4 | 6.4 | M16x1.5 | 10 | 42 | 23 | 32 | 19 |
| 3CF82-10-6 | 10 | 3/8 | -6 | 9.5 | M16x1.5 | 10 | 49 | 27 | 36 | 19 |
| 3CF82-10-6B | 10 | 3/8 | -6 | 9.5 | M16x1.5 | 10 | 49 | 27 | 36 | 19 |
| 3CF82-12-6 | 10 | 3/8 | -6 | 9.5 | M18x1.5 | 12 | 49 | 27 | 36 | 22 |
| 3CF82-12-6B | 10 | 3/8 | -6 | 9.5 | M18x1.5 | 12 | 49 | 27 | 36 | 22 |
| 3CF82-15-8 | 12 | 1/2 | -8 | 12.7 | M22x1.5 | 15 | 60 | 34 | 42 | 27 |
| 3CF82-15-8B | 12 | 1/2 | -8 | 12.7 | M22x1.5 | 15 | 60 | 34 | 42 | 27 |
| 3CF82-18-10 | 16 | 5/8 | -10 | 15.9 | M26x1.5 | 18 | 74 | 37 | 45 | 32 |
| 3CF82-22-12 | 19 | 3/4 | -12 | 19.1 | M30x2 | 22 | 88 | 52 | 55 | 36 |

Hose fittings are delivered with ozone resistant Nitrile (NBR) O-ring as a standard version. Working temperature from -40 °C up to +105 °C.
Hose fittings with special O-rings (Viton or EPDM) available on request. O-ring dimensions and part-numbers see in section Eb.

D0 Male Metric 24° Light Series – Rigid Straight

ISO 12151-2-S-L – CEL

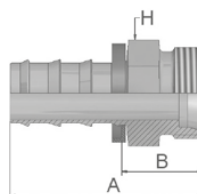

| Part Number | Hose I.D. | | | | Thread metric | Tube O.D. mm | A mm | B mm | H mm |
|--------------|-----------|------|------|------|------------------|--------------------|---------|---------|---------|
| | DN | Inch | Size | mm | | | | | |
| 3D082-6-4 | 6 | 1/4 | -4 | 6.4 | M12x1.5 | 6 | 35 | 16 | 12 |
| 3D082-8-4 | 6 | 1/4 | -4 | 6.4 | M14x1.5 | 8 | 36 | 17 | 14 |
| 3D082-10-6 | 10 | 3/8 | -6 | 9.5 | M16x1.5 | 10 | 41 | 18 | 17 |
| 3D082-10-6B | 10 | 3/8 | -6 | 9.5 | M16x1.5 | 10 | 41 | 18 | 17 |
| 3D082-12-6 | 10 | 3/8 | -6 | 9.5 | M18x1.5 | 12 | 41 | 18 | 19 |
| 3D082-12-6B | 10 | 3/8 | -6 | 9.5 | M18x1.5 | 12 | 41 | 18 | 19 |
| 3D082-15-8 | 12 | 1/2 | -8 | 12.7 | M22x1.5 | 15 | 49 | 23 | 22 |
| 3D082-15-8B | 12 | 1/2 | -8 | 12.7 | M22x1.5 | 15 | 49 | 22 | 22 |
| 3D082-18-8 | 12 | 1/2 | -8 | 12.7 | M26x1.5 | 18 | 48 | 21 | 27 |
| 3D082-18-10 | 16 | 5/8 | -10 | 15.9 | M26x1.5 | 18 | 58 | 21 | 27 |
| 3D082-22-12 | 19 | 3/4 | -12 | 19.1 | M30x2 | 22 | 63 | 27 | 30 |
| 3D082-22-12B | 19 | 3/4 | -12 | 19.1 | M30x2 | 22 | 63 | 27 | 30 |

Also available in stainless steel. Details can be found in CAT 4400.1/UK

Approved **fitting series** for hose types:

B: Brass

82 801Plus 801RH 804 821FR 830M 836 837BM 837PU 838M 846



B1b-2

Catalogue 4400/UK

C3 Female Metric Light Series – Swivel Straight (Ball Nose for 24° or 60° Cone)

DKL

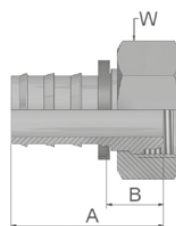

| Part Number | Hose I.D. | | | | Thread metric | Tube O.D. mm | A mm | B mm | W mm |
|--------------|-----------|------|------|------|------------------|--------------------|---------|---------|---------|
| | DN | Inch | Size | mm | | | | | |
| 3C382-6-4 | 6 | 1/4 | -4 | 6.4 | M12x1.5 | 6 | 33 | 14 | 14 |
| 3C382-6-4B | 6 | 1/4 | -4 | 6.4 | M12x1.5 | 6 | 33 | 14 | 14 |
| 3C382-8-4 | 6 | 1/4 | -4 | 6.4 | M14x1.5 | 8 | 33 | 14 | 17 |
| 3C382-8-4B | 6 | 1/4 | -4 | 6.4 | M14x1.5 | 8 | 36 | 16 | 19 |
| 3C382-10-4 | 6 | 1/4 | -4 | 6.4 | M16x1.5 | 10 | 34 | 15 | 19 |
| 3C382-10-4B | 6 | 1/4 | -4 | 6.4 | M16x1.5 | 10 | 34 | 15 | 19 |
| 3C382-10-6 | 10 | 3/8 | -6 | 9.5 | M16x1.5 | 10 | 37 | 15 | 19 |
| 3C382-10-6B | 10 | 3/8 | -6 | 9.5 | M16x1.5 | 10 | 38 | 15 | 19 |
| 3C382-12-6 | 10 | 3/8 | -6 | 9.5 | M18x1.5 | 12 | 38 | 16 | 22 |
| 3C382-12-6B | 10 | 3/8 | -6 | 9.5 | M18x1.5 | 12 | 40 | 17 | 22 |
| 3C382-15-8 | 12 | 1/2 | -8 | 12.7 | M22x1.5 | 15 | 42 | 15 | 27 |
| 3C382-15-8B | 12 | 1/2 | -8 | 12.7 | M22x1.5 | 15 | 42 | 15 | 27 |
| 3C382-15-10 | 16 | 5/8 | -10 | 15.9 | M22x1.5 | 15 | 56 | 19 | 27 |
| 3C382-18-10 | 16 | 5/8 | -10 | 15.9 | M26x1.5 | 18 | 53 | 17 | 32 |
| 3C382-18-10B | 16 | 5/8 | -10 | 15.9 | M26x1.5 | 18 | 58 | 22 | 32 |
| 3C382-22-12 | 19 | 3/4 | -12 | 19.1 | M30x2 | 22 | 53 | 17 | 36 |
| 3C382-22-12B | 19 | 3/4 | -12 | 19.1 | M30x2 | 22 | 53 | 17 | 36 |
| 3C382-28-16 | 25 | 1 | -16 | 25.4 | M36x2 | 28 | 58 | 22 | 41 |
| 3C382-28-16B | 25 | 1 | -16 | 25.4 | M36x2 | 28 | 58 | 22 | 41 |

82 Series

Also available in stainless steel. Details can be found in CAT 4400.1/UK

Approved **fitting series** for hose types:

B: Brass

82 801Plus 801RH 804 821FR 830M 836 837BM 837PU 838M 846



B1b-3

Catalogue 4400/UK

C4 Female Metric Light Series – Swivel 45° Elbow (Ball Nose for 24° or 60° Cone)

DKL 45°

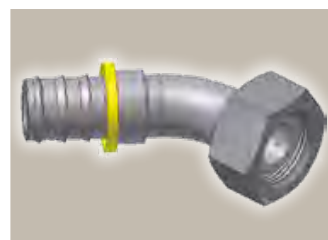
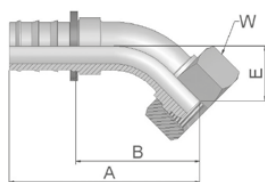

| Part Number | Hose I.D. | | | | Thread metric | Tube O.D. mm | A mm | B mm | E mm | W mm |
|--------------|-----------|------|------|------|------------------|--------------------|---------|---------|---------|---------|
| | DN | Inch | Size | mm | | | | | | |
| 3C482-6-4 | 6 | 1/4 | -4 | 6.4 | M12x1.5 | 6 | 51 | 32 | 16 | 14 |
| 3C482-6-4B | 6 | 1/4 | -4 | 6.4 | M12x1.5 | 6 | 51 | 32 | 16 | 14 |
| 3C482-8-4 | 6 | 1/4 | -4 | 6.4 | M14x1.5 | 8 | 51 | 32 | 16 | 17 |
| 3C482-8-4B | 6 | 1/4 | -4 | 6.4 | M14x1.5 | 8 | 51 | 32 | 16 | 17 |
| 3C482-10-6 | 10 | 3/8 | -6 | 9.5 | M16x1.5 | 10 | 58 | 35 | 18 | 19 |
| 3C482-10-6B | 10 | 3/8 | -6 | 9.5 | M16x1.5 | 10 | 58 | 35 | 17 | 19 |
| 3C482-12-6 | 10 | 3/8 | -6 | 9.5 | M18x1.5 | 12 | 59 | 36 | 18 | 22 |
| 3C482-12-6B | 10 | 3/8 | -6 | 9.5 | M18x1.5 | 12 | 58 | 36 | 18 | 22 |
| 3C482-15-8 | 12 | 1/2 | -8 | 12.7 | M22x1.5 | 15 | 68 | 41 | 19 | 27 |
| 3C482-15-8B | 12 | 1/2 | -8 | 12.7 | M22x1.5 | 15 | 67 | 41 | 19 | 27 |
| 3C482-15-10 | 16 | 5/8 | -10 | 15.9 | M22x1.5 | 15 | 82 | 45 | 21 | 27 |
| 3C482-18-10 | 16 | 5/8 | -10 | 15.9 | M26x1.5 | 18 | 81 | 45 | 21 | 32 |
| 3C482-18-10B | 16 | 5/8 | -10 | 15.9 | M26x1.5 | 18 | 81 | 45 | 21 | 32 |
| 3C482-18-12 | 19 | 3/4 | -12 | 19.1 | M26x1.5 | 18 | 96 | 60 | 26 | 32 |
| 3C482-22-12 | 19 | 3/4 | -12 | 19.1 | M30x2 | 22 | 88 | 52 | 23 | 36 |
| 3C482-22-12B | 19 | 3/4 | -12 | 19.1 | M30x2 | 22 | 88 | 52 | 23 | 36 |
| 3C482-28-16 | 25 | 1 | -16 | 25.4 | M36x2 | 28 | 110 | 73 | 31 | 41 |

Also available in stainless steel. Details can be found in CAT 4400.1/UK

Approved **fitting series** for hose types:

B: Brass

82 801Plus 801RH 804 821FR 830M 836 837BM 837PU 838M 846



B1b-4

Catalogue 4400/UK

C5 **Female Metric
Light Series – Swivel
90° Elbow (Ball Nose
for 24° or 60° Cone)**

DKL 90°

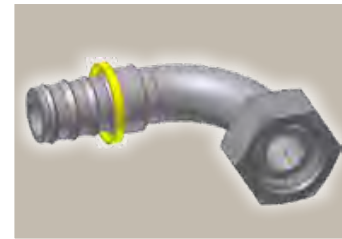
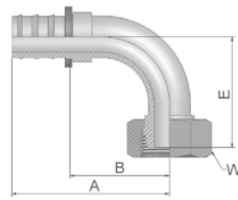

| Part Number | Hose I.D. | | | | Thread metric | Tube O.D. mm | A mm | B mm | E mm | W mm |
|--------------|-----------|------|------|------|------------------|--------------------|---------|---------|---------|---------|
| | DN | Inch | Size | mm | | | | | | |
| 3C582-6-4 | 6 | 1/4 | -4 | 6.4 | M12x1.5 | 6 | 42 | 23 | 29 | 14 |
| 3C582-8-4 | 6 | 1/4 | -4 | 6.4 | M14x1.5 | 8 | 42 | 23 | 29 | 17 |
| 3C582-8-4B | 6 | 1/4 | -4 | 6.4 | M14x1.5 | 8 | 41 | 23 | 29 | 17 |
| 3C582-10-4 | 6 | 1/4 | -4 | 6.4 | M16x1.5 | 10 | 42 | 23 | 29 | 19 |
| 3C582-10-6 | 10 | 3/8 | -6 | 9.5 | M16x1.5 | 10 | 49 | 27 | 33 | 19 |
| 3C582-12-6 | 10 | 3/8 | -6 | 9.5 | M18x1.5 | 12 | 49 | 27 | 34 | 22 |
| 3C582-12-6B | 10 | 3/8 | -6 | 9.5 | M18x1.5 | 12 | 49 | 27 | 34 | 22 |
| 3C582-15-8 | 12 | 1/2 | -8 | 12.7 | M22x1.5 | 15 | 65 | 38 | 39 | 27 |
| 3C582-15-8B | 12 | 1/2 | -8 | 12.7 | M22x1.5 | 15 | 65 | 38 | 39 | 27 |
| 3C582-18-10 | 16 | 5/8 | -10 | 15.9 | M26x1.5 | 18 | 74 | 37 | 43 | 32 |
| 3C582-18-10B | 16 | 5/8 | -10 | 15.9 | M26x1.5 | 18 | 74 | 37 | 43 | 32 |
| 3C582-22-12 | 19 | 3/4 | -12 | 19.1 | M30x2 | 22 | 88 | 51 | 50 | 36 |
| 3C582-22-12B | 19 | 3/4 | -12 | 19.1 | M30x2 | 22 | 88 | 52 | 50 | 36 |
| 3C582-28-16B | 25 | 1 | -16 | 25.4 | M36x2 | 28 | 101 | 64 | 66 | 41 |

82 Series

Also available in stainless steel. Details can be found in CAT 4400.1/UK

Approved **fitting series** for hose types:

B: Brass

82 801Plus 801RH 804 821FR 830M 836 837BM 837PU 838M 846



B1b-5

Catalogue 4400/UK

49 Metric Banjo Straight

DIN 7642

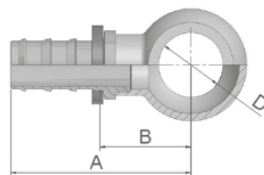

| Part Number | Hose I.D. | | | | A mm | B mm | D mm |
|-------------|---------------|------|------|------|---------|---------|---------|
| | DN | Inch | Size | mm | | | |
| 34982-8-4 | 6 | 1/4 | -4 | 6.4 | 36 | 17 | 8 |
| 34982-10-4 | 6 | 1/4 | -4 | 6.4 | 38 | 19 | 10 |
| 34982-12-4 | 6 | 1/4 | -4 | 6.4 | 40 | 21 | 12 |
| 34982-14-4 | 6 | 1/4 | -4 | 6.4 | 42 | 23 | 14 |
| 34982-10-6 | 10 | 3/8 | -6 | 9.5 | 42 | 19 | 10 |
| 34982-12-6 | 10 | 3/8 | -6 | 9.5 | 44 | 21 | 12 |
| 34982-14-6 | 10 | 3/8 | -6 | 9.5 | 47 | 24 | 14 |
| 34982-16-6 | 10 | 3/8 | -6 | 9.5 | 49 | 26 | 16 |
| 34982-17-6 | 10 | 3/8 | -6 | 9.5 | 49 | 26 | 17 |
| 34982-14-8 | 12 | 1/2 | -8 | 12.7 | 51 | 25 | 14 |
| 34982-18-8 | 12 | 1/2 | -8 | 12.7 | 55 | 28 | 18 |
| 34982-22-8 | 12 | 1/2 | -8 | 12.7 | 57 | 31 | 22 |
| 34982-22-10 | 16 | 5/8 | -10 | 15.9 | 68 | 32 | 22 |
| 34982-26-12 | 19 | 3/4 | -12 | 19.1 | 74 | 38 | 26 |

9B Female Metric Swivel Light Series Compact 45° Elbow (Ball Nose for 24° or 60° Cone)

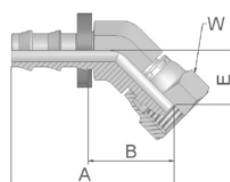

| Part Number | Hose I.D. | | | | Thread metric | Tube O.D. mm | A mm | B mm | E mm | W mm |
|-------------|---------------|------|------|------|----------------------|--------------------|---------|---------|---------|-------------|
| | DN | Inch | Size | mm | | | | | | |
| 39B82-6-4B | 6 | 1/4 | -4 | 6.4 | M12x1.5 | 6 | 44 | 25 | 16 | 14 |
| 39B82-8-4B | 6 | 1/4 | -4 | 6.4 | M14x1.5 | 8 | 43 | 24 | 15 | 19 |
| 39B82-10-6B | 10 | 3/8 | -6 | 9.5 | M16x1.5 | 10 | 48 | 25 | 16 | 19 |
| 39B82-12-6B | 10 | 3/8 | -6 | 9.5 | M18x1.5 | 12 | 50 | 27 | 17 | 22 |
| 39B82-15-8B | 12 | 1/2 | -8 | 12.7 | M22x1.5 | 15 | 54 | 28 | 18 | 27 |

Also available in stainless steel. Details can be found in CAT 4400.1/UK

Approved **fitting series** for hose types:

B: Brass

82 801Plus 801RH 804 821FR 830M 836 837BM 837PU 838M 846



B1b-6

Catalogue 4400/UK

Low Pressure
DIN – Metric

Push-Lok Fittings
82 Series

9C Female Metric Swivel
Light Series Compact
90° Elbow (Ball Nose
for 24° or 60° Cone)

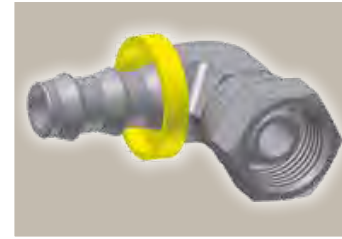
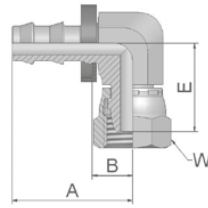

| Part Number | Hose I.D. | | | | Thread metric | Tube O.D. mm | A mm | B mm | E mm | W mm |
|-------------|-----------|------|------|------|------------------|--------------------|---------|---------|---------|---------|
| | DN | Inch | Size | mm | | | | | | |
| 39C82-6-4B | 6 | 1/4 | -4 | 6.4 | M12x1.5 | 6 | 30 | 11 | 22 | 14 |
| 39C82-8-4B | 6 | 1/4 | -4 | 6.4 | M14x1.5 | 8 | 30 | 11 | 22 | 19 |
| 39C82-10-6B | 10 | 3/8 | -6 | 9.5 | M16x1.5 | 10 | 34 | 12 | 25 | 19 |
| 39C82-12-6B | 10 | 3/8 | -6 | 9.5 | M18x1.5 | 12 | 34 | 11 | 25 | 22 |
| 39C82-15-8B | 12 | 1/2 | -8 | 12.7 | M22x1.5 | 15 | 42 | 16 | 32 | 27 |

82 Series

Also available in stainless steel. Details can be found in CAT 4400.1/UK

Approved **fitting series** for hose types:

B: Brass

82 801Plus 801RH 804 821FR 830M 836 837BM 837PU 838M 846



B1b-7

Catalogue 4400/UK

92 Female BSP Parallel Pipe Swivel – Straight (60° Cone)

BS5200-A – DKR

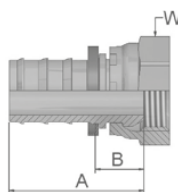

| Part Number | Hose I.D. | | | | Thread BSP | A mm | B mm | W mm |
|--------------|-----------|------|------|------|---------------|---------|---------|---------|
| | DN | Inch | Size | mm | | | | |
| 39282-4-4 | 6 | 1/4 | -4 | 6.4 | 1/4x19 | 33 | 14 | 17 |
| 39282-4-4B | 6 | 1/4 | -4 | 6.4 | 1/4x19 | 36 | 16 | 17 |
| 39282-6-4B | 6 | 1/4 | -4 | 6.4 | 3/8x19 | 37 | 18 | 22 |
| 39282-6-6 | 10 | 3/8 | -6 | 9.5 | 3/8x19 | 37 | 14 | 19 |
| 39282-8-8 | 12 | 1/2 | -8 | 12.7 | 1/2x14 | 42 | 15 | 27 |
| 39282-8-8B | 12 | 1/2 | -8 | 12.7 | 1/2x14 | 46 | 19 | 27 |
| 39282-10-10 | 16 | 5/8 | -10 | 15.9 | 5/8x14 | 53 | 16 | 30 |
| 39282-10-10B | 16 | 5/8 | -10 | 15.9 | 5/8x14 | 55 | 18 | 30 |
| 39282-12-12 | 19 | 3/4 | -12 | 19.1 | 3/4x14 | 58 | 21 | 32 |
| 39282-16-16B | 25 | 1 | -16 | 25.4 | 1x11 | 57 | 21 | 41 |

B1 Female BSP Parallel Pipe Swivel 45° Elbow (60° Cone)

BS 5200-D – DKR 45°

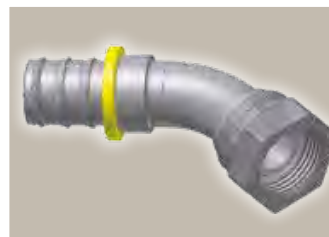
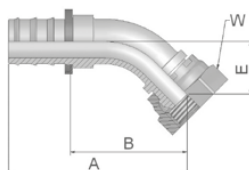

| Part Number | Hose I.D. | | | | Thread BSP | A mm | B mm | E mm | W mm |
|-------------|-----------|------|------|------|---------------|---------|---------|---------|---------|
| | DN | Inch | Size | mm | | | | | |
| 3B182-4-4 | 6 | 1/4 | -4 | 6.4 | 1/4x19 | 51 | 32 | 16 | 17 |
| 3B182-6-6 | 10 | 3/8 | -6 | 9.5 | 3/8x19 | 58 | 35 | 17 | 19 |
| 3B182-6-6B | 10 | 3/8 | -6 | 9.5 | 3/8x19 | 58 | 35 | 17 | 19 |
| 3B182-8-8 | 12 | 1/2 | -8 | 12.7 | 1/2x14 | 68 | 41 | 19 | 27 |
| 3B182-8-8B | 12 | 1/2 | -8 | 12.7 | 1/2x14 | 67 | 41 | 19 | 27 |
| 3B182-10-10 | 16 | 5/8 | -10 | 15.9 | 5/8x14 | 81 | 45 | 21 | 30 |
| 3B182-12-12 | 19 | 3/4 | -12 | 19.1 | 3/4x14 | 92 | 55 | 27 | 32 |
| 3B182-16-16 | 25 | 1 | -16 | 25.4 | 1x11 | 107 | 71 | 33 | 41 |

Also available in stainless steel. Details can be found in CAT 4400.1/UK

Approved **fitting series** for hose types:

B: Brass

82 801Plus 801RH 804 821FR 830M 836 837BM 837PU 838M 846



B1b-8

Catalogue 4400/UK

B2 Female BSP Parallel Pipe Swivel 90° Elbow (60° Cone)

BS 5200-B – DKR 90°

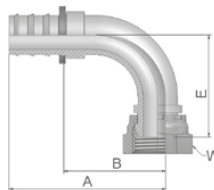

| Part Number | Hose I.D. | | | | Thread BSP | A mm | B mm | E mm | W mm |
|--------------|-----------|------|------|------|---------------|---------|---------|---------|---------|
| | DN | Inch | Size | mm | | | | | |
| 3B282-4-4 | 6 | 1/4 | -4 | 6.4 | 1/4x19 | 42 | 23 | 29 | 17 |
| 3B282-6-6 | 10 | 3/8 | -6 | 9.5 | 3/8x19 | 49 | 26 | 33 | 19 |
| 3B282-8-8 | 12 | 1/2 | -8 | 12.7 | 1/2x14 | 60 | 34 | 39 | 27 |
| 3B282-8-8B | 12 | 1/2 | -8 | 12.7 | 1/2x14 | 60 | 34 | 39 | 27 |
| 3B282-10-8 | 12 | 1/2 | -8 | 12.7 | 5/8x14 | 58 | 32 | 40 | 30 |
| 3B282-10-10 | 16 | 5/8 | -10 | 15.9 | 5/8x14 | 74 | 37 | 43 | 30 |
| 3B282-10-10B | 16 | 5/8 | -10 | 15.9 | 5/8x14 | 74 | 37 | 44 | 30 |
| 3B282-12-12 | 19 | 3/4 | -12 | 19.1 | 3/4x14 | 83 | 46 | 53 | 32 |
| 3B282-12-12B | 19 | 3/4 | -12 | 19.1 | 3/4x14 | 83 | 46 | 53 | 32 |
| 3B282-16-16 | 25 | 1 | -16 | 25.4 | 1x11 | 99 | 63 | 68 | 41 |

82 Series

D9 Male BSP Parallel Pipe Rigid – Straight (60° Cone)

BS5200 – AGR

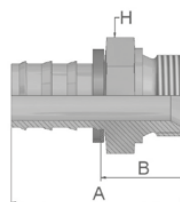

| Part Number | Hose I.D. | | | | Thread BSP | A mm | B mm | H mm |
|-------------|-----------|------|------|------|---------------|---------|---------|---------|
| | DN | Inch | Size | mm | | | | |
| 3D982-2-4 | 6 | 1/4 | -4 | 6.4 | 1/8x28 | 36 | 17 | 14 |
| 3D982-4-4 | 6 | 1/4 | -4 | 6.4 | 1/4x19 | 41 | 23 | 19 |
| 3D982-4-4B | 6 | 1/4 | -4 | 6.4 | 1/4x19 | 41 | 23 | 19 |
| 3D982-4-6 | 10 | 3/8 | -6 | 9.5 | 1/4x19 | 44 | 21 | 19 |
| 3D982-4-6B | 10 | 3/8 | -6 | 9.5 | 1/4x19 | 44 | 21 | 19 |
| 3D982-6-6 | 10 | 3/8 | -6 | 9.5 | 3/8x19 | 45 | 23 | 22 |
| 3D982-8-8 | 12 | 1/2 | -8 | 12.7 | 1/2x14 | 53 | 27 | 27 |
| 3D982-8-8B | 12 | 1/2 | -8 | 12.7 | 1/2x14 | 53 | 27 | 27 |
| 3D982-8-10 | 16 | 5/8 | -10 | 15.9 | 1/2x14 | 62 | 25 | 27 |
| 3D982-12-12 | 19 | 3/4 | -12 | 19.1 | 3/4x14 | 65 | 28 | 32 |

Also available in stainless steel. Details can be found in CAT 4400.1/UK

Approved **fitting series** for hose types:

B: Brass

82 801Plus 801RH 804 821FR 830M 836 837BM 837PU 838M 846



91 Male BSP Taper Pipe – Rigid Straight

BS5200 – AGR-K

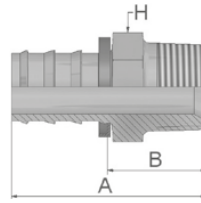

| Part Number | Hose I.D. | | | | Thread BSP | A mm | B mm | H mm |
|--------------|---------------|------|------|------|-------------------|---------|---------|-------------|
| | DN | Inch | Size | mm | | | | |
| 39182-2-4B | 6 | 1/4 | -4 | 6.4 | 1/8x28 | 37 | 18 | 12 |
| 39182-4-4B | 6 | 1/4 | -4 | 6.4 | 1/4x19 | 40 | 21 | 14 |
| 39182-4-6B | 10 | 3/8 | -6 | 9.5 | 1/4x19 | 44 | 21 | 14 |
| 39182-6-6B | 10 | 3/8 | -6 | 9.5 | 3/8x19 | 45 | 22 | 19 |
| 39182-6-8B | 12 | 1/2 | -8 | 12.7 | 3/8x19 | 49 | 22 | 19 |
| 39182-8-8B | 12 | 1/2 | -8 | 12.7 | 1/2x14 | 55 | 29 | 22 |
| 39182-8-10B | 16 | 5/8 | -10 | 15.9 | 1/2x14 | 65 | 28 | 22 |
| 39182-12-10B | 16 | 5/8 | -10 | 15.9 | 3/4x14 | 69 | 32 | 30 |
| 39182-12-12B | 19 | 3/4 | -12 | 19.1 | 3/4x14 | 69 | 32 | 30 |

34 Inch Standpipe (Brass)

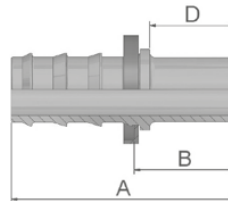

| Part Number | Hose I.D. | | | | Tube O.D. | A mm | B mm | D mm |
|--------------|---------------|------|------|------|--------------|---------|---------|---------|
| | DN | Inch | Size | mm | | | | |
| 33482-4-4B | 6 | 1/4 | -4 | 6.4 | 6.4 | 48 | 29 | 26 |
| 33482-6-6B | 10 | 3/8 | -6 | 9.5 | 9.5 | 57 | 34 | 31 |
| 33482-8-8B | 12 | 1/2 | -8 | 12.7 | 12.7 | 55 | 28 | 25 |
| 33482-10-10B | 16 | 5/8 | -10 | 15.9 | 15.9 | 67 | 30 | 25 |
| 33482-12-12B | 19 | 3/4 | -12 | 19.1 | 19.1 | 67 | 30 | 25 |

Also available in stainless steel. Details can be found in CAT 4400.1/UK

Approved **fitting series** for hose types:

B: Brass

82 801Plus 801RH 804 821FR 830M 836 837BM 837PU 838M 846



B1b-10

Catalogue 4400/UK

01 Male NPTF Pipe Rigid – Straight

SAE J476A / J516 – AGN

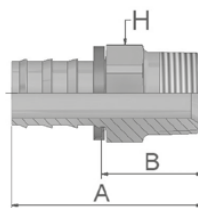

| Part Number | Hose I.D. | | | | Thread NPTF | A mm | B mm | H | |
|--------------|-----------|------|------|------|----------------|---------|---------|--------|------|
| | DN | Inch | Size | mm | | | | mm | Inch |
| 30182-2-4 | 6 | 1/4 | -4 | 6.4 | 1/8x27 | 35 | 16 | 7/16 | |
| 30182-2-4B | 6 | 1/4 | -4 | 6.4 | 1/8-27 | 35 | 16 | 7/16 | |
| 30182-4-4 | 6 | 1/4 | -4 | 6.4 | 1/4x18 | 40 | 21 | 9/16 | |
| 30182-4-4B | 6 | 1/4 | -4 | 6.4 | 1/4-18 | 40 | 21 | 9/16 | |
| 30182-4-6 | 10 | 3/8 | -6 | 9.5 | 1/4x18 | 45 | 22 | 9/16 | |
| 30182-4-6B | 10 | 3/8 | -6 | 9.5 | 1/4-18 | 45 | 22 | 9/16 | |
| 30182-6-6 | 10 | 3/8 | -6 | 9.5 | 3/8x18 | 45 | 22 | 11/16 | |
| 30182-6-8B | 12 | 1/2 | -8 | 12.7 | 3/8-18 | 49 | 22 | 11/16 | |
| 30182-8-8 | 12 | 1/2 | -8 | 12.7 | 1/2x14 | 55 | 29 | 7/8 | |
| 30182-8-8B | 12 | 1/2 | -8 | 12.7 | 1/2x14 | 55 | 29 | 7/8 | |
| 30182-8-10B | 16 | 5/8 | -10 | 15.9 | 1/2-14 | 66 | 29 | 7/8 | |
| 30182-12-10 | 16 | 5/8 | -10 | 15.9 | 3/4-14 | 66 | 29 | 1 1/16 | |
| 30182-8-12B | 19 | 3/4 | -12 | 19.1 | 1/2-14 | 66 | 29 | 7/8 | |
| 30182-12-12 | 19 | 3/4 | -12 | 19.1 | 3/4-14 | 66 | 29 | 1 1/16 | |
| 30182-12-12B | 19 | 3/4 | -12 | 19.1 | 3/4-14 | 66 | 29 | 1 1/16 | |

82 Series

02 Female NPTF Pipe – Rigid Straight

SAE J476A / J516

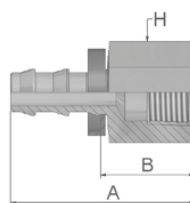

| Part Number | Hose I.D. | | | | Thread NPTF | A mm | B mm | H | |
|-------------|-----------|------|------|------|----------------|---------|---------|--------|------|
| | DN | Inch | Size | mm | | | | mm | Inch |
| 30282-4-4B | 6 | 1/4 | -4 | 6.4 | 1/4x18 | 40 | 21 | 3/4 | |
| 30282-6-6B | 10 | 3/8 | -6 | 9.5 | 3/8x18 | 46 | 23 | 7/8 | |
| 30282-8-8B | 12 | 1/2 | -8 | 12.7 | 1/2x14 | 55 | 28 | 1 1/16 | |

Also available in stainless steel. Details can be found in CAT 4400.1/UK

Approved **fitting series** for hose types:

B: Brass

82 801Plus 801RH 804 821FR 830M 836 837BM 837PU 838M 846



B1b-11

Catalogue 4400/UK

03 Male JIC 37° – Rigid Straight

ISO12151-5-S – AGJ

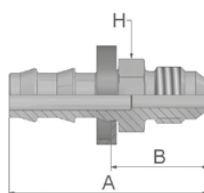

| Part Number | Hose I.D. | | | | Thread UNF | A mm | B mm | H Inch |
|-------------|-----------|------|------|------|---------------|---------|---------|-----------|
| | DN | Inch | Size | mm | | | | |
| 30382-4-4 | 6 | 1/4 | -4 | 6.4 | 7/16x20 | 40 | 21 | 1/2 |
| 30382-6-6 | 10 | 3/8 | -6 | 9.5 | 9/16x18 | 45 | 22 | 5/8 |
| 30382-6-6B | 10 | 3/8 | -6 | 9.5 | 9/16x18 | 45 | 22 | 5/8 |
| 30382-8-8 | 12 | 1/2 | -8 | 12.7 | 3/4x16 | 52 | 26 | 3/4 |
| 30382-12-12 | 19 | 3/4 | -12 | 19.1 | 1 1/16x12 | 69 | 32 | 1 1/8 |

06 Female JIC 37° – Swivel Straight

ISO12151-5-SWS – DKJ

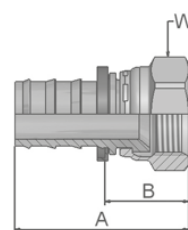

| Part Number | Hose I.D. | | | | Thread UNF | A mm | B mm | W mm Inch |
|--------------|-----------|------|------|------|---------------|---------|---------|--------------|
| | DN | Inch | Size | mm | | | | |
| 30682-4-4 | 6 | 1/4 | -4 | 6.4 | 7/16x20 | 39 | 20 | 9/16 |
| 30682-4-4B | 6 | 1/4 | -4 | 6.4 | 7/16x20 | 39 | 19 | 9/16 |
| 30682-5-4B | 6 | 1/4 | -4 | 6.4 | 1/2x20 | 40 | 21 | 5/8 |
| 30682-6-4B | 6 | 1/4 | -4 | 6.4 | 9/16x18 | 42 | 22 | 11/16 |
| 30682-5-6B | 10 | 3/8 | -6 | 9.5 | 1/2x20 | 44 | 21 | 5/8 |
| 30682-6-6 | 10 | 3/8 | -6 | 9.5 | 9/16x18 | 44 | 22 | 11/16 |
| 30682-6-6B | 10 | 3/8 | -6 | 9.5 | 9/16x18 | 44 | 22 | 11/16 |
| 30682-8-6B | 10 | 3/8 | -6 | 9.5 | 3/4x16 | 47 | 25 | 7/8 |
| 30682-8-8 | 12 | 1/2 | -8 | 12.7 | 3/4x16 | 51 | 25 | 7/8 |
| 30682-8-8B | 12 | 1/2 | -8 | 12.7 | 3/4x16 | 51 | 25 | 7/8 |
| 30682-10-8B | 12 | 1/2 | -8 | 12.7 | 7/8x14 | 52 | 25 | 1 |
| 30682-10-10 | 16 | 5/8 | -10 | 15.9 | 7/8x14 | 65 | 28 | 1 |
| 30682-10-10B | 16 | 5/8 | -10 | 15.9 | 7/8x14 | 62 | 25 | 1 |
| 30682-12-12 | 19 | 3/4 | -12 | 19.1 | 1 1/16x12 | 67 | 30 | 1 1/4 |
| 30682-12-12B | 19 | 3/4 | -12 | 19.1 | 1 1/16x12 | 67 | 30 | 1 1/4 |

Also available in stainless steel. Details can be found in CAT 4400.1/UK

Approved **fitting series** for hose types:

B: Brass

82 801Plus 801RH 804 821FR 830M 836 837BM 837PU 838M 846



08 Female SAE 45° – Swivel Straight

SAE J516

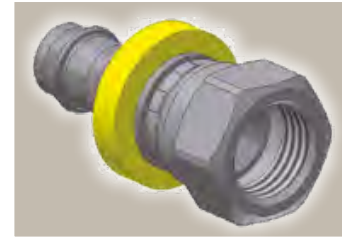
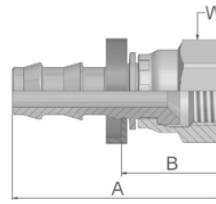

| Part Number | Hose I.D. | | | | Thread UNF | A mm | B mm | W inch |
|--------------|-----------|------|------|------|---------------|---------|---------|-----------|
| | DN | Inch | Size | mm | | | | |
| 30882-4-4 | 6 | 1/4 | -4 | 6.4 | 7/16x20 | 39 | 19 | 9/16 |
| 30882-4-4B | 6 | 1/4 | -4 | 6.4 | 7/16x20 | 39 | 19 | 9/16 |
| 30882-5-4B | 6 | 1/4 | -4 | 6.4 | 1/2x20 | 40 | 21 | 5/8 |
| 30882-6-6 | 10 | 3/8 | -6 | 9.5 | 5/8x18 | 46 | 23 | 3/4 |
| 30882-6-6B | 10 | 3/8 | -6 | 9.5 | 5/8x18 | 46 | 23 | 3/4 |
| 30882-8-8 | 12 | 1/2 | -8 | 12.7 | 3/4x16 | 51 | 25 | 7/8 |
| 30882-8-8B | 12 | 1/2 | -8 | 12.7 | 3/4x16 | 51 | 25 | 7/8 |
| 30882-10-10 | 16 | 5/8 | -10 | 15.9 | 7/8x14 | 65 | 28 | 1 |
| 30882-10-10B | 16 | 5/8 | -10 | 15.9 | 7/8x14 | 65 | 28 | 1 |
| 30882-12-12 | 19 | 3/4 | -12 | 19.1 | 1 1/16x14 | 67 | 30 | 1 1/4 |
| 30882-12-12B | 19 | 3/4 | -12 | 19.1 | 1 1/16x14 | 67 | 30 | 1 1/4 |

82 Series

37 Female JIC 37° – Swivel 45° Elbow

ISO 12151-5-SWE 45° – DKJ 45°

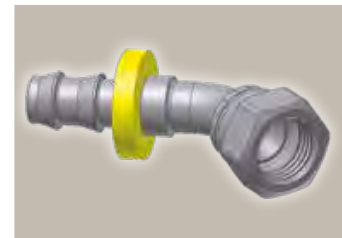
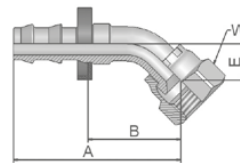

| Part Number | Hose I.D. | | | | Thread UNF | A mm | B mm | E mm | W mm Inch |
|-------------|-----------|------|------|------|---------------|---------|---------|---------|--------------|
| | DN | Inch | Size | mm | | | | | |
| 33782-4-4 | 6 | 1/4 | -4 | 6.4 | 7/16x20 | 39 | 20 | 8 | 9/16 |
| 33782-6-6 | 10 | 3/8 | -6 | 9.5 | 9/16x18 | 51 | 28 | 11 | 11/16 |
| 33782-8-8 | 12 | 1/2 | -8 | 12.7 | 3/4x16 | 54 | 35 | 14 | 7/8 |

Also available in stainless steel. Details can be found in CAT 4400.1/UK

Approved **fitting series** for hose types:

B: Brass

82 801Plus 801RH 804 821FR 830M 836 837BM 837PU 838M 846



B1b-13

Catalogue 4400/UK

Low Pressure
SAE

Push-Lok Fittings
82 Series

39 Female JIC 37° – Swivel 90° Elbow

ISO 12151-5-SWES – DKJ 90°

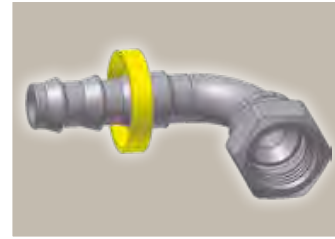
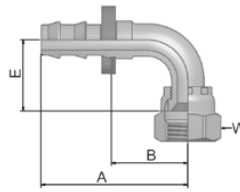

| Part Number | Hose I.D. | | | | Thread UNF | A mm | B mm | E mm | W | |
|-------------|-----------|------|------|------|---------------|---------|---------|---------|-------|------|
| | DN | Inch | Size | mm | | | | | mm | Inch |
| 33982-4-4 | 6 | 1/4 | -4 | 6.4 | 7/16x20 | 39 | 20 | 21 | 9/16 | |
| 33982-6-6 | 10 | 3/8 | -6 | 9.5 | 9/16x18 | 47 | 24 | 23 | 11/16 | |
| 33982-8-8 | 12 | 1/2 | -8 | 12.7 | 3/4x16 | 55 | 32 | 29 | 7/8 | |
| 33982-10-10 | 16 | 5/8 | -10 | 15.9 | 7/8x14 | 74 | 37 | 31 | 1 | |
| 33982-12-12 | 19 | 3/4 | -12 | 19.1 | 1 1/16x12 | 83 | 46 | 48 | 1 1/4 | |

Also available in stainless steel. Details can be found in CAT 4400.1/UK

Approved **fitting series** for hose types:

B: Brass

82 801Plus 801RH 804 821FR 830M 836 837BM 837PU 838M 846



B1b-14

Catalogue 4400/UK

Low Pressure
ORFS

Push-Lok Fittings
82 Series

JC **Female ORFS**
Swivel – Straight
Short

ISO 12151-1 – SWSA
SAE J516 – ORFS

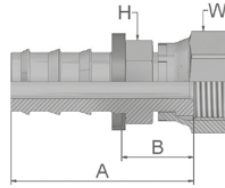

| Part Number | Hose I.D. | | | | Thread UNF | A mm | B mm | H | | W | |
|-------------|---------------|------|------|------|-------------------|---------|---------|-------|-------|-------|------|
| | DN | Inch | Size | mm | | | | mm | Inch | mm | Inch |
| 3JC82-4-4 | 6 | 1/4 | -4 | 6.4 | 9/16x18 | 36 | 17 | 9/16 | 11/16 | | |
| 3JC82-6-6 | 10 | 3/8 | -6 | 9.5 | 11/16x16 | 40 | 18 | 11/16 | 13/16 | | |
| 3JC82-10-10 | 16 | 5/8 | -10 | 15.9 | 1x14 | 61 | 24 | 15/16 | 1 1/8 | | |
| 3JC82-12-12 | 19 | 3/4 | -12 | 19.1 | 1 3/16x12 | 67 | 30 | 1 1/8 | 1 3/8 | | |

82 Series

Also available in stainless steel. Details can be found in CAT 4400.1/UK

Approved **fitting series** for hose types:

B: Brass

82 801Plus 801RH 804 821FR 830M 836 837BM 837PU 838M 846



B1b-15

Catalogue 4400/UK

FF Metru-Lok Swivel Female

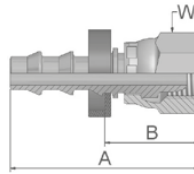

| Part Number | Hose I.D. | | | | Thread metric | Tube O.D. mm | A mm | B mm | W mm |
|--------------|-----------|------|------|------|------------------|--------------------|---------|---------|---------|
| | DN | Inch | Size | mm | | | | | |
| 3FF82-6-4B | 6 | 1/4 | -4 | 6.4 | M10x1 | 6 | 36 | 16 | 14 |
| 3FF82-8-4B | 6 | 1/4 | -4 | 6.4 | M12x1 | 8 | 31 | 12 | 14 |
| 3FF82-10-6B | 10 | 3/8 | -6 | 9.5 | M14x1 | 10 | 35 | 12 | 17 |
| 3FF82-12-6B | 10 | 3/8 | -6 | 9.5 | M16x1 | 12 | 35 | 12 | 19 |
| 3FF82-14-8B | 12 | 1/2 | -8 | 12.7 | M18x1 | 14 | 38 | 12 | 22 |
| 3FF82-16-8B | 12 | 1/2 | -8 | 12.7 | M22x1.5 | 16 | 38 | 12 | 27 |
| 3FF82-18-10B | 16 | 5/8 | -10 | 15.9 | M24x1.5 | 18 | 51 | 15 | 27 |
| 3FF82-22-12B | 19 | 3/4 | -12 | 19.1 | M28x1.5 | 22 | 51 | 15 | 32 |

AF Male BSP Parallel Pipe Rigid – Straight (with O-ring Seal)

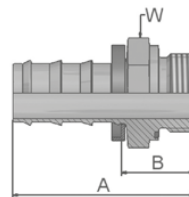

| Part Number | Hose I.D. | | | | Thread BSP | A mm | B mm | W mm |
|-------------|-----------|------|------|------|---------------|---------|---------|---------|
| | DN | Inch | Size | mm | | | | |
| 3AF82-2-4B | 6 | 1/4 | -4 | 6.4 | 1/8x28 | 34 | 15 | 17 |
| 3AF82-4-4B | 6 | 1/4 | -4 | 6.4 | 1/4x19 | 39 | 20 | 19 |
| 3AF82-4-6B | 10 | 3/8 | -6 | 9.5 | 1/4x19 | 43 | 20 | 19 |
| 3AF82-6-6B | 10 | 3/8 | -6 | 9.5 | 3/8x19 | 46 | 23 | 22 |
| 3AF82-6-8B | 12 | 1/2 | -8 | 12.7 | 3/8x19 | 49 | 22 | 22 |
| 3AF82-8-8B | 12 | 1/2 | -8 | 12.7 | 1/2x14 | 53 | 26 | 27 |
| 3AF82-8-10B | 16 | 5/8 | -10 | 15.9 | 1/2x14 | 63 | 27 | 27 |

Also available in stainless steel. Details can be found in CAT 4400.1/UK

Approved **fitting series** for hose types:

B: Brass

82 801Plus 801RH 804 821FR 830M 836 837BM 837PU 838M 846



B1b-16

Catalogue 4400/UK

82 Push-Lok® Union

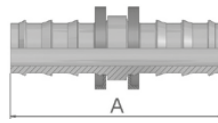

| Part Number | Hose I.D. | | | | A mm |
|--------------|-----------|------|------|------|---------|
| | DN | Inch | Size | mm | |
| 38282-4-4 | 6 | 1/4 | -4 | 6.4 | 45 |
| 38282-4-4B | 6 | 1/4 | -4 | 6.4 | 46 |
| 38282-6-6B | 10 | 3/8 | -6 | 9.5 | 55 |
| 38282-8-8 | 12 | 1/2 | -8 | 12.7 | 64 |
| 38282-8-8B | 12 | 1/2 | -8 | 12.7 | 64 |
| 38282-10-10 | 16 | 5/8 | -10 | 15.9 | 84 |
| 38282-10-10B | 16 | 5/8 | -10 | 15.9 | 84 |
| 38282-12-12 | 19 | 3/4 | -12 | 19.1 | 84 |
| 38282-12-12B | 19 | 3/4 | -12 | 19.1 | 84 |

82 Series

5C 60° Cone Swivel Female

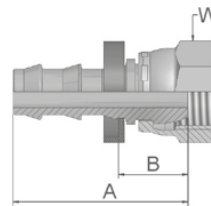

| Part Number | Hose I.D. | | | | Thread metric | A mm | B mm | W mm |
|--------------|-----------|------|------|------|------------------|---------|---------|---------|
| | DN | Inch | Size | mm | | | | |
| 35C82-6-4B | 6 | 1/4 | -4 | 6.4 | M12x1.5 | 33 | 14 | 14 |
| 35C82-10-6B | 10 | 3/8 | -6 | 9.5 | M16x1.5 | 38 | 15 | 19 |
| 35C82-15-8B | 12 | 1/2 | -8 | 12.7 | M22x1.5 | 44 | 18 | 27 |
| 35C82-18-10B | 16 | 5/8 | -10 | 15.9 | M26x1.5 | 57 | 21 | 32 |

Approved **fitting series** for hose types:

Also available in stainless steel. Details can be found in CAT 4400.1/UK

B: Brass

82 801Plus 801RH 804 821FR 830M 836 837BM 837PU 838M 846



B1b-17

Catalogue 4400/UK

6C 60° Cone Swivel Female 45° Elbow

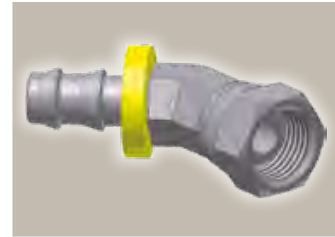
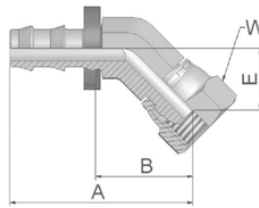

| Part Number | Hose I.D. | | | | Thread metric | A mm | B mm | E mm | W mm |
|-------------|-----------|------|------|------|------------------|---------|---------|---------|---------|
| | DN | Inch | Size | mm | | | | | |
| 36C82-6-4B | 6 | 1/4 | -4 | 6.4 | M12x1.5 | 44 | 25 | 16 | 14 |
| 36C82-10-6B | 10 | 3/8 | -6 | 9.5 | M16x1.5 | 48 | 26 | 16 | 19 |
| 36C82-15-8B | 12 | 1/2 | -8 | 12.7 | M22x1.5 | 54 | 28 | 18 | 27 |

7C 60° Cone Swivel Female 90° Elbow

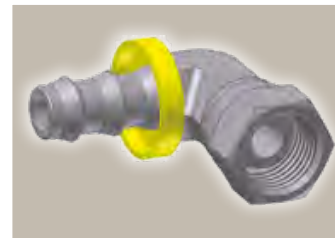
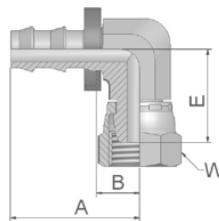

| Part Number | Hose I.D. | | | | Thread metric | A mm | B mm | E mm | W mm |
|-------------|-----------|------|------|------|------------------|---------|---------|---------|---------|
| | DN | Inch | Size | mm | | | | | |
| 37C82-6-4B | 6 | 1/4 | -4 | 6.4 | M12x1.5 | 30 | 11 | 22 | 14 |
| 37C82-10-6B | 10 | 3/8 | -6 | 9.5 | M16x1.5 | 34 | 12 | 25 | 19 |
| 37C82-15-8B | 12 | 1/2 | -8 | 12.7 | M22x1.5 | 43 | 16 | 32 | 27 |

Also available in stainless steel. Details can be found in CAT 4400.1/UK

Approved **fitting series** for hose types:

B: Brass

82 801Plus 801RH 804 821FR 830M 836 837BM 837PU 838M 846



B1b-18

Catalogue 4400/UK

Easy assembly – no tools or clamps required

Assembly Instructions



1. Cut the hose right angled with a sharp knife. If necessary it is possible to use a lubricant (water/soap solution with 5 % soap fluid and 95 % water) for easy assembly.

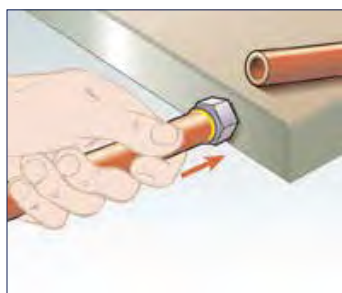

2. Insert fitting into hose until first barb is in hose. Place end of fitting against a flat object (bench, door, wall) and grip hose approximately 1" from end and push with a steady force until end of hose is covered by yellow plastic collar. Alternatively please use the Parker Assembly Tool No. 611050G or 611050HV.

82 Series

Attention!

During assembly, please keep in mind that Push-Lok fittings will provide an effective grip only when the Push-Lok hose is pushed fully on the insert, where the cropped end of the hose should be fully concealed by the plastic collar. **For easy assembly of hose 830M, 837BM and 837PU please use only Push-Lok Assembly Oil No. H896137.** Push-Lok Assembly Oil is free from wetting disturbing substances. Don't use oil, lubricant or soap fluids for this hose!

Disassembly Instructions

1. Cut lengthwise along a line at approximately a 20 angle from centre line of hose. The cut should be approximately 1" long. Be careful not to nick barbs when cutting the hose.



2. Grip hose and give a sharp down-ward tug to disengage from fitting.



Attention!

Before re-use of the nipple please check nipple for damage. Damaged nipples can cause leakage.

Low Pressure Transportation and Hydraulic Hose and Fittings

– the right solution for special applications and requirements



- A wide range of different hose types in rubber is available, with textile-braided or fire-retardant covers
- Proven, safe and easy self-assembly system
- Large bore sizes available
- High working temperatures
- One fitting series for all SAE 100 R5 and similar hoses

Applications

The definitive hose range for all special applications and requirements



B2-2

Parkrimp® *No-Skive*

The system for fast and leak-free assemblies

The perfect match



The complete system from one source. No-Skive hose, No-Skive fitting and crimping machine with world-wide guarantee and availability.

Parker's colour-coded die sets



No loose parts to mismatch or misplace – die set segments linked together.

Die sets provide 360° evenly applied crimping forces for an ideal crimp result.

Parkalign®



Parker's exclusive Parkalign® positions the fitting in the dies perfectly every time.



KarryKrimp® 1

KarryKrimp® 2

Parkrimp®

KarryKrimp® 2 Bench Mount



Parkrimp® *No-Skive*

- No skiving tool needed
- No need to remove the cover
- Crimps one-piece fittings
- Parkalign positions the fittings in the dies perfectly every time
- Quick and easy: no gauges to set on the machine
- Portable machines for field repair
- Meets EN safety regulations

Low Pressure Transportation and Hydraulic

| Hoses | | Page |
|--------------|------------------|--------|
| 201 | Transportation | B2a-1 |
| 206 | Transportation | B2a-2 |
| 213 | Transportation | B2a-3 |
| 221FR | Fire retardant | B2a-4 |
| 244 | Refrigeration | B2a-5 |
| 285 | Refrigeration | B2a-6 |
| 293 | Transportation | B2a-7 |
| 611HT | High temperature | B2a-8 |
| 681 | Standard | B2a-9 |
| 681DB | Railway | B2a-10 |

| | |
|------------------------|-------|
| Fittings Series | 26 |
| Chapter | B2b |
| DIN – Metric | 1 – 2 |
| SAE | 3 – 5 |
| ORFS | 6 |
| Others | 7 |

Parker Hannifin assumes no liability for typographical errors or other errors



Standard



High temperature



Railway



Transportation



Fire retardant



Refrigeration



201

No-Skive Airbrake

SAE 100R5 – SAE J1402AII

Primary Applications

Transportation: Air brake hose

General: Low pressure applications

Type Approvals

Details please find on pages **Ab-16** to **Ab-19**

Applicable Specifications

SAE 100R5, SAE J1402AII, D. O. T. FMVSS 106-AII

Construction

Inner tube: Synthetic rubber

Reinforcement: One fibre braid

One high-tensile steel wire braid

Cover: Rubber layer and textile braided cover

Temperature Range -40 °C up to +150 °C

Exception: Air max. +70 °C

Water max. +85 °C



- Textile braided cover
- **No-Skive** hose construction
- 150 °C working temperature

Recommended Fluids

Petroleum based hydraulic fluids, water-glycol and water-oil emulsion hydraulic fluids, grease, lubricants, crude and fuel oils, air and water.

Consult the chemical compatibility section on pages **Ab-26** to **Ab-34** for more detailed information.

Fitting Series



Hose

| Part Number | Hose I.D. | | | Hose O.D. mm | Pressure Rating | | | | Vacuum* kPa | min. bend radius mm | weight kg |
|-------------|-----------|------|------|-----------------|------------------------------|------|----------------------------|-------|----------------|------------------------|--------------|
| | Inch | Size | mm | | max. working pressure MPa | psi | min. burst pressure MPa | psi | | | |
| 201-4 | 3/16 | -4 | 5.0 | 12.2 | 20.7 | 3000 | 83.0 | 12000 | 95 | 75 | 0.22 |
| 201-5 | 1/4 | -5 | 6.3 | 14.8 | 20.7 | 3000 | 83.0 | 12000 | 95 | 85 | 0.27 |
| 201-6 | 5/16 | -6 | 8.0 | 17.2 | 15.5 | 2250 | 62.0 | 9000 | 95 | 100 | 0.34 |
| 201-8 | 13/32 | -8 | 10.0 | 19.5 | 13.8 | 2000 | 55.0 | 8000 | 95 | 120 | 0.40 |
| 201-10 | 1/2 | -10 | 12.5 | 23.4 | 12.0 | 1750 | 48.0 | 7000 | 95 | 140 | 0.55 |
| 201-12 | 5/8 | -12 | 16.0 | 27.4 | 10.3 | 1500 | 41.0 | 6000 | 95 | 165 | 0.68 |
| 201-16 | 7/8 | -16 | 22.0 | 31.4 | 5.5 | 800 | 22.0 | 3200 | 67 | 185 | 0.68 |
| 201-20 | 1 1/8 | -20 | 29.0 | 38.1 | 4.3 | 625 | 17.0 | 2500 | 67 | 230 | 0.76 |
| 201-24 | 1 3/8 | -24 | 35.0 | 44.5 | 3.5 | 500 | 14.0 | 2000 | 51 | 265 | 1.01 |
| 201-32 | 1 13/16 | -32 | 46.0 | 56.4 | 2.4 | 350 | 10.0 | 1400 | 37 | 335 | 1.32 |

* The vacuum values listed in the table are vacuum pressure values in kPa. For an absolute value subtract the table value from 101kPa.

The combination of high temperature and high pressure could reduce the hose life.

The maximum working pressures shown in the table are for service up to a maximum temperature of 100 °C.

For use at higher temperatures, consult the pressure/temperature curve in section A for the reduced maximum working pressure.

Hose layline example

201-6 AIR BRAKE DOT XXXXX All 8 mm [5/16] SAE J1402 DOT XXXXX All WP 15,7 MPa (2250 PSI) DOT XXXXX All SA



B2a-1

Catalogue 4400/UK

Low Pressure

Transportation and Hydraulic – Transportation

Parkrimp No-Skive Hose

206

206

No-Skive Airbrake

SAE 100R5 – SAE J1402AII



- Blue textile braided cover
- *No-Skive* hose construction
- For very low (-48 °C) working temperature

Primary Applications

Transportation: Air brake hose

General: Low pressure applications

Type Approvals

Details please find on pages **Ab-16** to **Ab-19**

Applicable Specifications

SAE 100R5, SAE J1402AII, D. O. T. FMVSS 106-AII

Construction

Inner tube: PKR synthetic rubber

Reinforcement: One fibre braid

One high-tensile steel wire braid

Cover: Rubber layer and

blue textile braided cover

Recommended Fluids

Petroleum based hydraulic fluids, water-glycol and water-oil emulsion hydraulic fluids, grease, lubricants, crude and fuel oils, air and water.

Consult the chemical compatibility section on pages **Ab-26** to **Ab-34** for more detailed information.

Temperature Range -48 °C up to +150 °C

Exception: Air max. +100 °C

Water max. +85 °C

Fitting Series



| Part Number | Hose I.D. | | | Hose O.D. mm | Pressure Rating | | | | Vacuum* kPa | min. bend radius mm | weight kg |
|-------------|-----------|------|------|-----------------|------------------------------|------|----------------------------|-------|----------------|------------------------|--------------|
| | Inch | Size | mm | | max. working pressure MPa | psi | min. burst pressure MPa | psi | | | |
| 206-4 | 3/16 | -4 | 5.0 | 13.2 | 20.7 | 3000 | 83.0 | 12000 | 95 | 75 | 0.22 |
| 206-5 | 1/4 | -5 | 6.3 | 14.8 | 20.7 | 3000 | 83.0 | 12000 | 95 | 85 | 0.27 |
| 206-6 | 5/16 | -6 | 8.0 | 17.1 | 15.5 | 2250 | 62.0 | 9000 | 95 | 90 | 0.34 |
| 206-8 | 13/32 | -8 | 10.0 | 19.5 | 13.8 | 2000 | 55.0 | 8000 | 95 | 90 | 0.40 |
| 206-10 | 1/2 | -10 | 12.5 | 23.4 | 12.0 | 1750 | 48.0 | 7000 | 95 | 100 | 0.55 |
| 206-12 | 5/8 | -12 | 16.0 | 27.4 | 10.3 | 1500 | 41.0 | 6000 | 95 | 100 | 0.68 |
| 206-16 | 7/8 | -16 | 22.0 | 31.4 | 5.5 | 800 | 22.0 | 3200 | 67 | 100 | 0.68 |
| 206-20 | 1 1/8 | -20 | 29.0 | 38.1 | 4.3 | 625 | 17.0 | 2500 | 67 | 140 | 0.76 |
| 206-24 | 1 3/8 | -24 | 35.0 | 44.5 | 3.5 | 500 | 14.0 | 2000 | 51 | 190 | 1.01 |
| 206-32 | 1 13/16 | -32 | 46.0 | 56.4 | 2.4 | 350 | 10.0 | 1400 | 37 | 335 | 1.32 |

* The vacuum values listed in the table are vacuum pressure values in kPa. For an absolute value subtract the table value from 101kPa.

The combination of high temperature and high pressure could reduce the hose life.

The maximum working pressures shown in the table are for service up to a maximum temperature of 100 °C.

For use at higher temperatures, consult the pressure/temperature curve in section A for the reduced maximum working pressure.

Hose layline example



B2a-2

Catalogue 4400/UK

213

No-Skive High Temperature

For engines and compressed air systems



- **No-Skive** hose construction
- Ideal for high-temperature and small bend radii applications
- Compatible with a large range of fluids

Primary Applications

Transportation: Air brake hose
Compressors: Compressed air hose

Type Approvals

Details please find on pages **Ab-16** to **Ab-19**

Applicable Specifications

SAE J1402AI, D.O.T. FMVSS 106-AI

Construction

Inner tube: PKR synthetic rubber
Reinforcement: One fibre braid
One high-tensile steel wire braid
Cover: Rubber layer and
black textile braided cover
include 2 green strips

Recommended Fluids

Petroleum based hydraulic fluids, water-glycol and water-oil emulsion hydraulic fluids, grease, lubricants, crude and fuel oils, air and water.

Consult the chemical compatibility section on pages **Ab-26** to **Ab-34** for more detailed information.

Temperature Range -45 °C up to +150 °C

Exception: Air max. +100 °C

Water max. +85 °C

Fitting Series



| Part Number | Hose I.D. | | | Hose O.D. mm | Pressure rating | | | | min. bend radius mm | weight kg |
|-------------|-----------|------|------|-----------------|------------------------------|------|----------------------------|------|------------------------|--------------|
| | Inch | Size | mm | | max. working pressure MPa | psi | min. burst pressure MPa | psi | | |
| 213-4 | 3/16 | -4 | 5.0 | 12.5 | 13.8 | 2000 | 55.0 | 8000 | 20 | 0.18 |
| 213-5 | 1/4 | -5 | 6.3 | 14.1 | 10.3 | 1500 | 41.0 | 6000 | 25 | 0.21 |
| 213-6 | 5/16 | -6 | 8.0 | 15.7 | 10.3 | 1500 | 41.0 | 6000 | 30 | 0.25 |
| 213-8 | 13/32 | -8 | 10.0 | 18.7 | 8.6 | 1250 | 34.0 | 5000 | 45 | 0.30 |
| 213-10 | 1/2 | -10 | 12.5 | 21.1 | 6.9 | 1000 | 28.0 | 4000 | 55 | 0.33 |
| 213-12 | 5/8 | -12 | 16.0 | 24.3 | 5.2 | 750 | 21.0 | 3000 | 70 | 0.36 |
| 213-16 | 7/8 | -16 | 22.0 | 30.6 | 2.8 | 400 | 11.0 | 1600 | 90 | 0.45 |
| 213-20 | 1 1/8 | -20 | 29.0 | 37.8 | 2.1 | 300 | 8.0 | 1200 | 115 | 0.65 |
| 213-24 | 1 3/8 | -24 | 35.0 | 44.0 | 1.7 | 300 | 8.0 | 1200 | 190 | 0.73 |
| 213-32 | 1 13/16 | -32 | 46.0 | 54.5 | 1.4 | 200 | 5.5 | 800 | 355 | 1.00 |

The combination of high temperature and high pressure could reduce the hose life.
The maximum working pressures shown in the table are for service up to a maximum temperature of 100 °C.
For use at higher temperatures, consult the pressure/temperature curve in section A for the reduced maximum working pressure.

Hose layline example

PARKER 213-16 WP 2,8 MPa [400 PSI] 22 mm [7/8] 3Q88 ————— PARKER 213-16 WP 2,8



221FR

No-Skive Fire Retardant

Marine fuel and engine hose



- Fire retardant hose cover
- *No-Skive* hose construction
- Marine approvals

Primary Applications

Marine: Marine fuel hose
General: Where fire retardance is an issue

Type Approvals

Details please find on pages **Ab-16** to **Ab-19**

Applicable Specifications

SAE J1527 R3, USCG Type AI, SAE J1942, ISO 7840

Construction

Inner tube: Fuel and oil-resistant rubber
Reinforcement: One high-tensile steel wire braid
Cover: Flame retardant special fibre outer cover

Temperature Range -20 °C up to +100 °C

Exception: Air max. +70 °C
Water max. +85 °C

Recommended Fluids

Petroleum based hydraulic fluids, water-glycol and water-oil emulsion hydraulic fluids, grease, lubricants, crude, fuel oils and water.

Consult the chemical compatibility section on pages **Ab-26** to **Ab-34** for more detailed information.

Fitting Series



| Part Number | Hose I.D. | | | Hose O.D. mm | Pressure Rating | | | | Vacuum* kPa | min. bend radius mm | weight kg |
|-------------|-----------|------|------|-----------------|------------------------------|-----|----------------------------|------|----------------|------------------------|--------------|
| | Inch | Size | mm | | max. working pressure MPa | psi | min. burst pressure MPa | psi | | | |
| 221FR-5 | 1/4 | -5 | 6.3 | 15 | 3.5 | 500 | 14.0 | 2000 | 81 | 25 | 0.28 |
| 221FR-6 | 5/16 | -6 | 8.0 | 17 | 3.5 | 500 | 14.0 | 2000 | 81 | 30 | 0.34 |
| 221FR-8 | 13/32 | -8 | 10.0 | 20 | 3.5 | 500 | 14.0 | 2000 | 81 | 45 | 0.42 |
| 221FR-10 | 1/2 | -10 | 12.5 | 23 | 3.5 | 500 | 14.0 | 2000 | 68 | 55 | 0.58 |
| 221FR-12 | 5/8 | -12 | 16.0 | 27 | 3.5 | 500 | 14.0 | 2000 | 68 | 70 | 0.61 |
| 221FR-16 | 7/8 | -16 | 22.0 | 31 | 3.5 | 500 | 14.0 | 2000 | 68 | 90 | 0.70 |

* The vacuum values listed in the table are vacuum pressure values in kPa. For an absolute value subtract the table value from 101kPa. The combination of high temperature and high pressure could reduce the hose life.

Hose layline example

PARKER 221FR-10 SAE J1527 USC6 TYPE A1 CE 1Q85 ISO 7840-A1 WITH 26 SERIES CRIMP FITTINGS ONLY



B2a-4

Catalogue 4400/UK

244

Air Conditioning and Refrigeration

SAE J2064 B Class I



- Excellent effusion rate
- Long service life
- Resists moisture ingress

Primary Applications

For bus- and train applications

Applicable Specifications

SAE J2064 B Class I

Construction

Inner tube: Butyl Gummi
Reinforcement: One high-tensile steel wire braid
Cover: Fibre braid

Recommended Fluids

For use with Freon refrigerants 12, 134a and 22.
Consult the chemical compatibility section on pages **Ab-26** to **Ab-34** for more detailed information.

Temperature Range -30 °C up to +125 °C

Hose

Fitting Series



| Part Number | Hose I.D. | | | Hose O.D. mm | Pressure Rating | | | | Vacuum* | min. bend radius mm | weight kg |
|-------------|-----------|------|----|-----------------|------------------------------|-----|----------------------------|------|---------|------------------------|--------------|
| | Inch | Size | mm | | max. working pressure MPa | psi | min. burst pressure MPa | psi | | | |
| 244-16 | 7/8 | 16 | 22 | 31 | 3.5 | 500 | 14 | 2000 | 95 | 190 | 0.76 |
| 244-20 | 1-1/8 | 20 | 29 | 38 | 3.5 | 500 | 14 | 2000 | 95 | 230 | 0.83 |
| 244-24 | 1-3/8 | 24 | 35 | 44 | 2.4 | 350 | 9.6 | 1400 | 95 | 270 | 0.92 |

* The vacuum values listed in the table are vacuum pressure values in kPa. For an absolute value subtract the table value from 101kPa. The combination of high temperature and high pressure could reduce the hose life.

Hose layline example



B2a-5

Catalogue 4400/UK

285

Air Conditioning and Refrigeration

SAE J3062 Type C



- *No-Skive* hose construction
- Usable for main refrigerant fluids
- Compatible with modern refrigerants

Primary Applications

Air Conditioning: For industrial and mobile applications

Applicable Specifications

SAE J3062 Type C

Construction

Inner tube: Synthetic rubber with nylon barrier.
Reinforcement: One fiber braid.
Cover: Synthetic rubber.

Recommended Fluids

Refrigerants R134a / PAG Oil & R1234yf / PAG Oil.
Consult the chemical compatibility section on pages **Ab-26** to **Ab-34** for more detailed information.

Temperature Range -40 °C to +125 °C

Fitting Series



| Part Number | Hose I.D. | | | Hose O.D. mm | Pressure Rating | | | | Vacuum* kPa | min. bend radius mm | weight kg |
|-------------|-----------|------|------|-----------------|------------------------------|-----|----------------------------|------|----------------|------------------------|--------------|
| | Inch | Size | mm | | max. working pressure MPa | psi | min. burst pressure MPa | psi | | | |
| 285-4-RL | 3/16 | -4 | 5.0 | 12.4 | 3.4 | 500 | 17.2 | 2500 | 95 | 25 | 0.14 |
| 285-6-RL | 5/16 | -6 | 8.0 | 15.7 | 3.4 | 500 | 17.2 | 2500 | 95 | 38 | 0.19 |
| 285-8-RL | 13/32 | -8 | 10.0 | 18.8 | 3.4 | 500 | 17.2 | 2500 | 95 | 51 | 0.25 |
| 285-10-RL | 1/2 | -10 | 12.5 | 21.1 | 3.4 | 500 | 17.2 | 2500 | 95 | 64 | 0.27 |
| 285-12-RL | 5/8 | -12 | 16.0 | 24.4 | 3.4 | 500 | 17.2 | 2500 | 95 | 76 | 0.34 |

* The vacuum values listed in the table are vacuum pressure values in kPa. For an absolute value subtract the table value from 101kPa.
For size -16 a hose 285-16 is available on request.
RL = only available on reels.

Hose layline example

PARKER 285-10 WP 3,4 MPa (500 PSI) SAE J3062 TYPE C 12,5 mm (1/2) 10-4Q09



B2a-6

Catalogue 4400/UK

293

No-Skive High Temperature Engine and air brake/truck hose

Primary Applications

Truck Market: Air brake hose
Engine cooling circuit

Type Approvals

Details please find on pages **Ab-16** to **Ab-19**

Applicable Specifications

SAE J1402AI, D.O.T. FMVSS 106

Construction

Inner tube: PKR synthetic rubber
Reinforcement: One fibre braid
Cover: Black nylon braid

Temperature Range -50 °C up to +150 °C

Exception: Air max. +100 °C
Water max. +85 °C



- High temperature
– high flex hose performance
- **No-Skive** hose construction
- Wide temperature range

Recommended Fluids

Petroleum-based hydraulic fluids and lubrication oils, diesel fuels and antifreeze solutions; water-, water-oil- and water-glycol emulsion hydraulic fluids.
Consult the chemical compatibility section on pages **Ab-26** to **Ab-34** for more detailed information.

Fitting Series



Hose

| Part Number | Hose I.D. | | | Hose O.D. mm | Pressure rating | | | | min. bend radius mm | weight kg |
|-------------|-----------|------|------|-----------------|------------------------------|-----|----------------------------|------|------------------------|--------------|
| | Inch | Size | mm | | max. working pressure MPa | psi | min. burst pressure MPa | psi | | |
| 293-4-RL | 3/16 | -4 | 5.0 | 12.5 | 3.5 | 500 | 13.8 | 2000 | 15 | 0.15 |
| 293-6-RL | 5/16 | -6 | 8.0 | 15.7 | 3.5 | 500 | 13.8 | 2000 | 25 | 0.22 |
| 293-8-RL | 13/32 | -8 | 10.0 | 18.7 | 3.5 | 500 | 13.8 | 2000 | 40 | 0.27 |
| 293-10-RL | 1/2 | -10 | 12.5 | 21.1 | 3.1 | 450 | 12.4 | 1800 | 50 | 0.30 |
| 293-12-RL | 5/8 | -12 | 16.0 | 24.3 | 3.1 | 450 | 12.4 | 1800 | 65 | 0.33 |
| 293-16-RL | 7/8 | -16 | 22.0 | 30.6 | 3.1 | 450 | 12.4 | 1800 | 80 | 0.37 |

The combination of high temperature and high pressure could reduce the hose life.
RL = only available on reels.

Hose layline example

PARKER 293-6 AIR BRAKE 8 mm (5/16) SAE J1402 W.P. 3,5 MPa (500 PSI) ————— PARKER 293-6



B2a-7

Catalogue 4400/UK

Low Pressure

Transportation and Hydraulic – High temperature

Parkrimp No-Skive Hose

611HT

611HT

No-Skive

High-temperature textile hose

Primary Applications

General Market: Low pressure hydraulic applications/
high temperature applications

Engine Applications:

Diesel fuel lines, engine cooling circuits

Type Approvals

Details please find on pages **Ab-16** to **Ab-19**

Applicable Specifications

EN 854-R6

Construction

Inner tube: PKR synthetic rubber

Reinforcement: One fibre braid

Cover: MSHA approved synthetic rubber

Temperature Range -40 °C up to +150 °C

Exception: Air max. +100 °C

Water max. +85 °C



- For high demand applications, such as diesel fuel lines, water cooling or high-temp lines up to +150 °C
- MSHA approved
- According to EN 854-R6
- *No-Skive* hose construction for 2-piece fittings

Recommended Fluids

Petroleum-based hydraulic fluids and lubrication oils, diesel fuels and antifreeze solutions; water-glycol and water-oil emulsion, air and water.

Consult the chemical compatibility section on pages **Ab-26** to **Ab-34** for more detailed information.

Fitting Series

- Compatible with 2-piece fittings for use with adjustable crimpers only (47 series nipple and 10064 series shell)

| Part Number | Hose I.D. | | | | Hose O.D. mm | Pressure Rating | | | | min. bend radius mm | weight kg |
|-------------|-----------|------|------|------|-----------------|------------------------------|-----|----------------------------|------|------------------------|--------------|
| | DN | Inch | Size | mm | | max. working pressure MPa | psi | min. burst pressure MPa | psi | | |
| 611HT-4 | 6 | 1/4 | -4 | 6.4 | 12.8 | 2.8 | 400 | 11.2 | 1600 | 65 | 0.13 |
| 611HT-5 | 8 | 5/16 | -5 | 7.9 | 14.6 | 2.8 | 400 | 11.2 | 1600 | 70 | 0.15 |
| 611HT-6 | 10 | 3/8 | -6 | 9.5 | 16.0 | 2.8 | 400 | 11.2 | 1600 | 75 | 0.16 |
| 611HT-8 | 12 | 1/2 | -8 | 12.7 | 20.0 | 2.8 | 400 | 11.2 | 1600 | 100 | 0.27 |
| 611HT-10 | 16 | 5/8 | -10 | 15.9 | 23.2 | 2.4 | 350 | 9.6 | 1400 | 125 | 0.28 |
| 611HT-12 | 19 | 3/4 | -12 | 19.1 | 26.2 | 2.1 | 300 | 8.4 | 1200 | 150 | 0.36 |
| 611HT-16 | 25 | 1 | -16 | 25.4 | 33.1 | 2.0 | 290 | 8.0 | 1160 | 200 | 0.46 |

The combination of high temperature and high pressure could reduce the hose life.

Hose layline example

PARKER 611HT-4 HI-TEMP WP 2,8 MPa (400 PSI) MSHA IC-40/10 | • • SAE 100R6-4 6,3 mm (1/4) X 1F EN854/R6/



B2a-8

Catalogue 4400/UK

681

No-Skive 2TE
EN 854-2TE



- One layer of fabric braid
- *No-Skive* hose construction
- Small bend radii

Primary Applications

General Market: Low pressure hydraulic application

Applicable Specifications

EN 854-2TE

Construction

Inner tube: Synthetic rubber
Reinforcement: One fibre braid
Cover: Synthetic rubber

Temperature Range -40 °C up to +100 °C

Exception: Air max. +70 °C
Water max. +85 °C

Recommended Fluids

Petroleum based hydraulic fluids, water-glycol and water-oil emulsion hydraulic fluids, grease, lubricants, crude and fuel oils, air and water.

Consult the chemical compatibility section on pages **Ab-26** to **Ab-34** for more detailed information.

Fitting Series

- Compatible with 2-piece fittings for use with adjustable crimpers only (47 series nipple and 10064 series shell)

Hose

| Part Number | Hose I.D. | | | | Hose O.D. mm | Pressure Rating | | | | min. bend radius mm | weight kg |
|-------------|-----------|------|------|------|-----------------|------------------------------|------|----------------------------|------|------------------------|--------------|
| | DN | Inch | Size | mm | | max. working pressure MPa | psi | min. burst pressure MPa | psi | | |
| 681-4 | 6 | 1/4 | -4 | 6.4 | 13.6 | 7.5 | 1090 | 30.0 | 4360 | 40 | 0.15 |
| 681-5 | 8 | 5/16 | -5 | 7.9 | 14.8 | 6.8 | 980 | 27.0 | 3920 | 50 | 0.16 |
| 681-6 | 10 | 3/8 | -6 | 9.5 | 16.6 | 6.3 | 910 | 25.0 | 3640 | 60 | 0.19 |
| 681-8 | 12 | 1/2 | -8 | 12.7 | 19.6 | 5.8 | 840 | 23.0 | 3360 | 70 | 0.24 |
| 681-10 | 16 | 5/8 | -10 | 15.9 | 23.9 | 5.0 | 725 | 20.0 | 2900 | 90 | 0.35 |
| 681-12 | 19 | 3/4 | -12 | 19.1 | 27.0 | 4.5 | 650 | 18.0 | 2600 | 110 | 0.39 |
| 681-16 | 25 | 1 | -16 | 25.4 | 34.4 | 4.0 | 580 | 16.0 | 2320 | 150 | 0.59 |

The combination of high temperature and high pressure could reduce the hose life.

Hose layline example

PARKER 681-4 WP 7,5 MPa (1090 PSI) | • • 6,3 mm (1/4) EN854/2TE/6/DIN made in Italy



B2a-9

Catalogue 4400/UK

681DB

No-Skive 2TE

EN 854-2TE

(with approvals for rail transportation)

Primary Applications

General Market: Low pressure hydraulic application

Rail Transportation Market:

Hydraulic applications around
train vehicles

Type Approvals

Details please find on pages **Ab-16** to **Ab-19**

Applicable Specifications

EN 854-2TE

Construction

Inner tube: Synthetic rubber

Reinforcement: One fibre braid

Cover: Flame retardant synthetic rubber

Temperature Range -40 °C up to +100 °C

Exception: Air max. +70 °C

Water max. +85 °C



- One layer of fabric braid
- *No-Skive* hose construction
- Small bend radii
- Flame retardant rubber cover
- Railway approved:
 - European Standard EN45545 HL2 for R22 (internal) and R23 (external)
 - ISO 15540 (FS-F-Fire Sleeve needed)

Recommended Fluids

Petroleum based hydraulic fluids, water-glycol and water-oil emulsion hydraulic fluids, grease, lubricants, crude and fuel oils, air and water.

Consult the chemical compatibility section on pages **Ab-26** to **Ab-34** for more detailed information.

Fitting Series

- Compatible with 2-piece fittings for use with adjustable crimpers only (47 series nipple and 10064 series shell)

| Part Number | Hose I.D. | | | | Hose O.D. mm | Pressure Rating | | | | min. bend radius mm | weight kg |
|-------------|-----------|------|------|------|-----------------|------------------------------|------|----------------------------|------|------------------------|--------------|
| | DN | Inch | Size | mm | | max. working pressure MPa | psi | min. burst pressure MPa | psi | | |
| 681DB-4 | 6 | 1/4 | -4 | 6.4 | 13.6 | 7.5 | 1090 | 30.0 | 4360 | 40 | 0.15 |
| 681DB-5 | 8 | 5/16 | -5 | 7.9 | 14.8 | 6.8 | 980 | 27.0 | 3920 | 50 | 0.16 |
| 681DB-6 | 10 | 3/8 | -6 | 9.5 | 16.6 | 6.3 | 910 | 25.0 | 3640 | 60 | 0.19 |
| 681DB-8 | 12 | 1/2 | -8 | 12.7 | 19.6 | 5.8 | 840 | 23.0 | 3360 | 70 | 0.24 |
| 681DB-10 | 16 | 5/8 | -10 | 15.9 | 23.9 | 5.0 | 725 | 20.0 | 2900 | 90 | 0.35 |
| 681DB-12 | 19 | 3/4 | -12 | 19.1 | 27.0 | 4.5 | 650 | 18.0 | 2600 | 110 | 0.39 |
| 681DB-16 | 25 | 1 | -16 | 25.4 | 34.4 | 4.0 | 580 | 16.0 | 2320 | 150 | 0.59 |

The combination of high temperature and high pressure could reduce the hose life.

Hose layline example

PARKER 681DB-6 WP 6,3 MPa (910 PSI) 1° 10 mm (3/8) EN854/2TE/10/DIN MADE IN ITALY





DIN – Metric

Page B2b-1 – B2b-2

| | | | |
|--------------------------------------------------------------------------------------------------------------------------------------------------------------------------------------------------------------------|-------------------------------------------------------------------------------------------------------------------------------------------------------------------------------------------------------------------------|--------------------------------------------------------------------------------------------------------------------------------------------------------------------------------------------------------------------------|-----------------------------------------------------------------------------------------------------------------------------------------------------------|
| <p>CA B2b-1 Female Metric 24° Light Series with O-Ring Swivel – Straight ISO 12151-2-SWS-L – DKOL</p>  | <p>CE B2b-1 Female Metric 24° Light Series with O-Ring Swivel – 45° Elbow ISO 12151-2-SWE-L – DKOL 45°</p>  | <p>CF B2b-2 Female Metric 24° Light Series with O-Ring Swivel – 90° Elbow ISO 12151-2-SWE-L – DKOL 90°</p>  | <p>49 B2b-2 Metric Banjo Straight DIN 7642</p>  |
|--------------------------------------------------------------------------------------------------------------------------------------------------------------------------------------------------------------------|-------------------------------------------------------------------------------------------------------------------------------------------------------------------------------------------------------------------------|--------------------------------------------------------------------------------------------------------------------------------------------------------------------------------------------------------------------------|-----------------------------------------------------------------------------------------------------------------------------------------------------------|

SAE

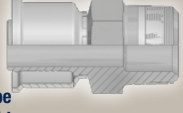
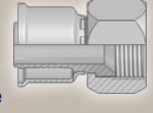
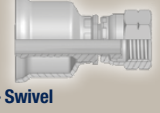
Page B2b-3 – B2b-5

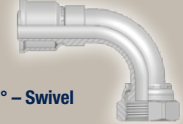
| | | | |
|---------------------------------------------------------------------------------------------------------------------------------------------------------------------------------------|------------------------------------------------------------------------------------------------------------------------------------------------------------------------------------------------------------|---------------------------------------------------------------------------------------------------------------------------------------------------------------------|-----------------------------------------------------------------------------------------------------------------------------------------------------------------------------------------------------------------------------|
| <p>01 B2b-3 Male NPTF Pipe Rigid – Straight SAE J476A / J516 – AGN</p>  | <p>06/68 B2b-3 Female – JIC 37° SAE 45° Dual Flare Swivel – Straight ISO12151-5-SWS – DKJ</p>  | <p>08 B2b-4 Female SAE 45° – Swivel Straight SAE J516</p>  | <p>37/3V B2b-4 Female JIC 37° SAE 45° – Dual Flare Swivel Female 45° Elbow ISO 12151-5-SWE 45° – DKJ 45°</p>  |
| <p>39 B2b-5 Female JIC 37° – Swivel 90° Elbow ISO 12151-5-SWES – DKJ 90°</p>  | | | |

ORFS



Page B2b-6

JC
B2b-6
Female ORFS
Swivel – Straight
Short
ISO 12151-1 – SWSA SAE J516 – ORFS



Others

Page B2b-7

| | |
|--------------------------------------------------------------------------------------------------------------------------------------------------------------|--------------------------------------------------------------------------------------------------------------------------------------------------------------------------|
| <p>5S B2b-7 Female Tube O-ring Swivel Short Pilot</p>  | <p>5T B2b-7 Female Tube O-Ring Swivel 90° Elbow – Short Pilot</p>  |
|--------------------------------------------------------------------------------------------------------------------------------------------------------------|--------------------------------------------------------------------------------------------------------------------------------------------------------------------------|

CA **Female Metric 24°
Light Series with O-Ring
Swivel – Straight**
ISO 12151-2-SWS-L – DKOL

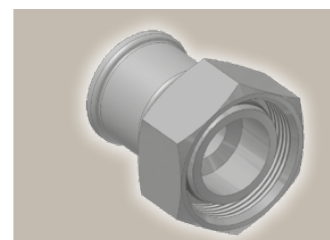
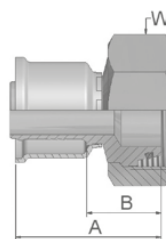

| Part Number | Hose I.D. | | | Thread metric | Tube O.D. mm | A mm | B mm | W mm |
|-------------|-----------|------|------|------------------|--------------------|---------|---------|---------|
| | Inch | Size | mm | | | | | |
| 1CA26-8-4 | 3/16 | -4 | 5.0 | M14x1.5 | 8 | 42 | 21 | 17 |
| 1CA26-10-5 | 1/4 | -5 | 6.3 | M16x1.5 | 10 | 41 | 20 | 19 |
| 1CA26-10-6 | 5/16 | -6 | 8.0 | M16x1.5 | 10 | 41 | 20 | 19 |
| 1CA26-12-6 | 5/16 | -6 | 8.0 | M18x1.5 | 12 | 42 | 21 | 22 |
| 1CA26-12-8 | 13/32 | -8 | 10.0 | M18x1.5 | 12 | 42 | 21 | 22 |
| 1CA26-15-8 | 13/32 | -8 | 10.0 | M22x1.5 | 15 | 42 | 22 | 27 |
| 1CA26-18-10 | 1/2 | -10 | 12.5 | M26x1.5 | 18 | 46 | 23 | 32 |
| 1CA26-18-12 | 5/8 | -12 | 16.0 | M26x1.5 | 18 | 46 | 23 | 32 |
| 1CA26-22-12 | 5/8 | -12 | 16.0 | M30x2 | 22 | 48 | 25 | 36 |
| 1CA26-28-16 | 7/8 | -16 | 22.0 | M36x2 | 28 | 54 | 28 | 41 |
| 1CA26-28-20 | 1 1/8 | -20 | 29.0 | M36x2 | 28 | 61 | 33 | 41 |
| 1CA26-35-20 | 1 1/8 | -20 | 29.0 | M45x2 | 35 | 56 | 29 | 50 |
| 1CA26-35-24 | 1 3/8 | -24 | 35.0 | M45x2 | 35 | 62 | 34 | 50 |
| 1CA26-42-24 | 1 3/8 | -24 | 35.0 | M52x2 | 42 | 59 | 31 | 60 |

26 Series

Hose fittings are delivered with ozone resistant Nitrile (NBR) O-ring as a standard version. Working temperature from -40 °C up to +105 °C. Hose fittings with special O-rings (Viton or EPDM) available on request. O-ring dimensions and part-numbers see in section Eb.

CE **Female Metric 24°
Light Series with O-Ring
Swivel – 45° Elbow**
ISO 12151-2-SWE -L – DKOL 45°

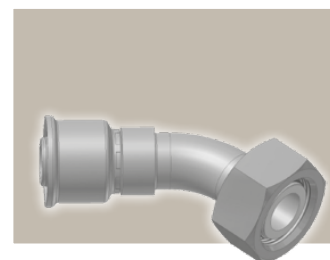
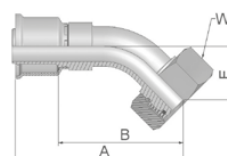

| Part Number | Hose I.D. | | | Thread metric | Tube O.D. mm | A mm | B mm | E mm | W mm |
|-------------|-----------|------|------|------------------|--------------------|---------|---------|---------|---------|
| | Inch | Size | mm | | | | | | |
| 1CE26-10-6 | 5/16 | -6 | 8.0 | M16x1.5 | 10 | 67 | 46 | 18 | 19 |
| 1CE26-12-6 | 5/16 | -6 | 8.0 | M18x1.5 | 12 | 66 | 46 | 18 | 22 |
| 1CE26-12-8 | 13/32 | -8 | 10.0 | M18x1.5 | 12 | 61 | 40 | 17 | 22 |
| 1CE26-15-8 | 13/32 | -8 | 10.0 | M22x1.5 | 15 | 60 | 40 | 17 | 27 |
| 1CE26-18-10 | 1/2 | -10 | 12.5 | M26x1.5 | 18 | 68 | 46 | 20 | 32 |
| 1CE26-18-12 | 5/8 | -12 | 16.0 | M26x1.5 | 18 | 73 | 50 | 22 | 32 |
| 1CE26-22-12 | 5/8 | -12 | 16.0 | M30x2 | 22 | 77 | 55 | 26 | 36 |
| 1CE26-28-16 | 7/8 | -16 | 22.0 | M36x2 | 28 | 105 | 78 | 33 | 41 |

Hose fittings are delivered with ozone resistant Nitrile (NBR) O-ring as a standard version. Working temperature from -40 °C up to +105 °C. Hose fittings with special O-rings (Viton or EPDM) available on request. O-ring dimensions and part-numbers see in section Eb.

Approved **fitting series** for hose types:

26 201 206 213 221FR 244 285 293



CF **Female Metric 24°
Light Series with O-Ring
Swivel – 90° Elbow**
ISO 12151-2-SWE-L – DKOL 90°

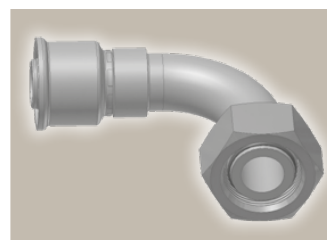
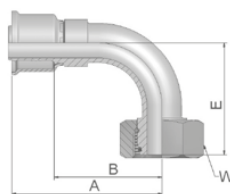

| Part Number | Hose I.D. | | | Thread metric | Tube O.D. mm | A mm | B mm | E mm | W mm |
|-------------|-----------|------|------|------------------|--------------------|---------|---------|---------|---------|
| | Inch | Size | mm | | | | | | |
| 1CF26-8-4 | 3/16 | -4 | 5.0 | M14x1.5 | 8 | 45 | 24 | 29 | 17 |
| 1CF26-10-5 | 1/4 | -5 | 6.3 | M16x1.5 | 10 | 55 | 36 | 30 | 19 |
| 1CF26-10-6 | 5/16 | -6 | 8.0 | M16x1.5 | 10 | 55 | 34 | 32 | 19 |
| 1CF26-12-6 | 5/16 | -6 | 8.0 | M18x1.5 | 12 | 56 | 35 | 36 | 22 |
| 1CF26-12-8 | 13/32 | -8 | 10.0 | M18x1.5 | 12 | 50 | 30 | 32 | 22 |
| 1CF26-15-8 | 13/32 | -8 | 10.0 | M22x1.5 | 15 | 58 | 38 | 42 | 27 |
| 1CF26-18-10 | 1/2 | -10 | 12.5 | M26x1.5 | 18 | 57 | 34 | 38 | 32 |
| 1CF26-18-12 | 5/8 | -12 | 16.0 | M26x1.5 | 18 | 69 | 46 | 45 | 32 |
| 1CF26-22-12 | 5/8 | -12 | 16.0 | M30x2 | 22 | 78 | 55 | 47 | 36 |
| 1CF26-18-16 | 7/8 | -16 | 22.0 | M26x1.5 | 18 | 92 | 65 | 70 | 32 |
| 1CF26-28-16 | 7/8 | -16 | 22.0 | M36x2 | 28 | 96 | 70 | 71 | 41 |
| 1CF26-28-20 | 1 1/8 | -20 | 29.0 | M36x2 | 28 | 117 | 90 | 81 | 41 |
| 1CF26-35-20 | 1 1/8 | -20 | 29.0 | M45x2 | 35 | 117 | 90 | 77 | 50 |
| 1CF26-35-24 | 1 3/8 | -24 | 35.0 | M45x2 | 35 | 117 | 89 | 79 | 50 |

Hose fittings are delivered with ozone resistant Nitrile (NBR) O-ring as a standard version. Working temperature from -40 °C up to +105 °C.
Hose fittings with special O-rings (Viton or EPDM) available on request. O-ring dimensions and part-numbers see in section Eb.

49 **Metric Banjo
Straight**
DIN 7642

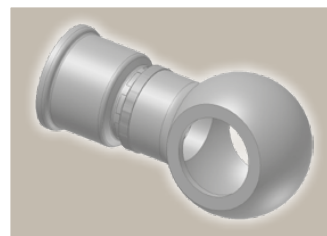
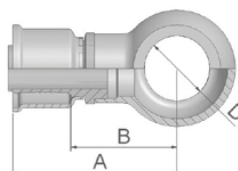

| Part Number | Hose I.D. | | | A mm | B mm | D mm |
|-------------|-----------|------|------|---------|---------|---------|
| | Inch | Size | mm | | | |
| 14926-12-6 | 5/16 | -6 | 8.0 | 47 | 26 | 12 |
| 14926-14-6 | 5/16 | -6 | 8.0 | 49 | 28 | 14 |
| 14926-14-8 | 13/32 | -8 | 10.0 | 48 | 28 | 14 |
| 14926-16-8 | 13/32 | -8 | 10.0 | 50 | 30 | 16 |

Approved **fitting series** for hose types:

| | | | | | | | |
|-----------|-----|-----|-----|-------|-----|-----|-----|
| 26 | 201 | 206 | 213 | 221FR | 244 | 285 | 293 |
|-----------|-----|-----|-----|-------|-----|-----|-----|



01 Male NPTF Pipe Rigid – Straight

SAE J476A / J516 – AGN

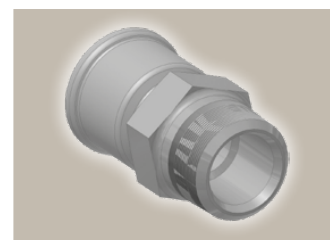
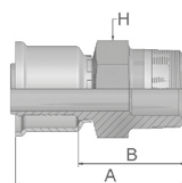

| Part Number | Hose I.D. | | | Thread NPTF | A mm | B mm | H Inch |
|-------------|-----------|------|------|----------------|---------|---------|-----------|
| | Inch | Size | mm | | | | |
| 10126-4-5 | 1/4 | -5 | 6.3 | 1/4-18 | 48 | 26 | 9/16 |
| 10126-4-6 | 5/16 | -6 | 8.0 | 1/4-18 | 48 | 26 | 3/4 |
| 10126-6-6 | 5/16 | -6 | 8.0 | 3/8-18 | 48 | 26 | 11/16 |
| 10126-6-8 | 13/32 | -8 | 10.0 | 3/8-18 | 48 | 26 | 11/16 |
| 10126-8-8 | 13/32 | -8 | 10.0 | 1/2-14 | 54 | 33 | 7/8 |
| 10126-8-10 | 1/2 | -10 | 12.5 | 1/2-14 | 57 | 33 | 7/8 |
| 10126-12-12 | 5/8 | -12 | 16.0 | 3/4-14 | 59 | 35 | 1 1/16 |

26 Series

06/68 Female – JIC 37° SAE 45° Dual Flare Swivel – Straight

ISO12151-5-SWS – DKJ

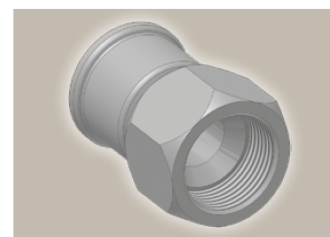
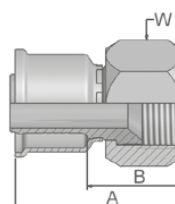

| Part Number | Hose I.D. | | | Thread UNF | Tube mm | A mm | B mm | W mm Inch |
|---------------|-----------|------|------|---------------|------------|---------|---------|--------------|
| | Inch | Size | mm | | | | | |
| 16826-4-4 | 3/16 | -4 | 5.0 | 7/16x20 | 1/4 | 42 | 20 | 9/16 |
| 16826-5-5BA | 1/4 | -5 | 6.3 | 1/2x20 | 5/16 | 45 | 23 | 5/8 |
| 10626-6-6 | 5/16 | -6 | 8.0 | 9/16x18 | 3/8 | 45 | 23 | 11/16 |
| 10626-6-6BS | 5/16 | -6 | 8.0 | 9/16x18 | 3/8 | 45 | 23 | 11/16 |
| 16826-8-8 | 13/32 | -8 | 10.0 | 3/4x16 | 1/2 | 49 | 27 | 7/8 |
| 16826-8-10 | 1/2 | -10 | 12.5 | 3/4x16 | 1/2 | 60 | 36 | 7/8 |
| 16826-10-10 | 1/2 | -10 | 12.5 | 7/8x14 | 5/8 | 55 | 31 | 1 |
| 16826-10-10BA | 1/2 | -10 | 12.5 | 7/8x14 | 5/8 | 55 | 31 | 1 |
| 16826-10-12 | 5/8 | -12 | 16.0 | 7/8x14 | 5/8 | 61 | 37 | 1 |
| 10626-12-12 | 5/8 | -12 | 16.0 | 1 1/16x12 | 3/4 | 58 | 34 | 1 1/4 |
| 10626-16-16 | 7/8 | -16 | 22.0 | 1 5/16x12 | 1 | 64 | 38 | 1 1/2 |
| 10626-20-20 | 1 1/8 | -20 | 29.0 | 1 5/8x12 | 1 1/4 | 65 | 38 | 2 |
| 10626-24-24 | 1 3/8 | -24 | 35.0 | 1 7/8x12 | 1 1/2 | 70 | 43 | 2 1/4 |
| 10626-32-32 | 1 13/16 | -32 | 46.0 | 2 1/2x12 | 2 | 84 | 52 | 2 7/8 |

Approved **fitting series** for hose types: **BA**: Nipple: Brass, Nut and Shell: Steel; **BS**: Nipple and Nut: Brass, Shell: Steel; **SM**: Metric Hexagon

26 201 206 213 221FR 244 285 293



08 Female SAE 45° – Swivel Straight

SAE J516

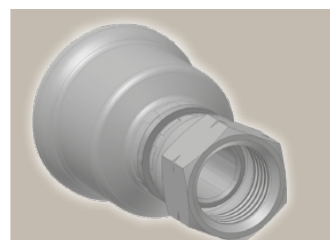
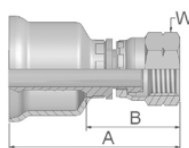

| Part Number | Hose I.D. | | | Thread UNF | Tube mm | A mm | B mm | W Inch |
|-------------|-----------|------|------|---------------|------------|---------|---------|-----------|
| | Inch | Size | mm | | | | | |
| 10826-6-6 | 5/16 | -6 | 8.0 | 5/8x18 | 3/8 | 47 | 25 | 3/4 |
| 10826-6-6BA | 5/16 | -6 | 8.0 | 5/8x18 | 3/8 | 47 | 25 | 3/4 |
| 10826-12-12 | 5/8 | -12 | 16.0 | 1 1/16x14 | 3/4 | 56 | 32 | 1 1/4 |

37/3V Female JIC 37° SAE 45° – Dual Flare Swivel Female 45° Elbow

ISO 12151-5-SWE 45° – DKJ 45°

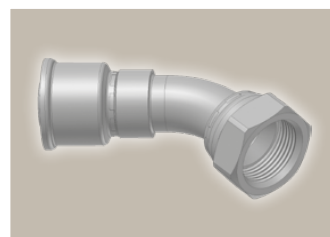
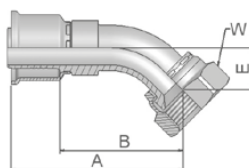

| Part Number | Hose I.D. | | | Thread UNF | Tube mm | A mm | B mm | E mm | W mm Inch |
|-------------|-----------|------|------|---------------|------------|---------|---------|---------|--------------|
| | Inch | Size | mm | | | | | | |
| 13726-4-4 | 3/16 | -4 | 5.0 | 7/16x20 | - | 51 | 29 | 10 | 9/16 |
| 13726-6-6 | 5/16 | -6 | 8.0 | 9/16x18 | 3/8 | 69 | 47 | 11 | 11/16 |
| 13726-8-8 | 13/32 | -8 | 10.0 | 3/4x16 | - | 72 | 50 | 15 | 7/8 |
| 13V26-10-10 | 1/2 | -10 | 12.5 | 7/8x14 | 5/8 | 69 | 44 | 17 | 1 |
| 13726-12-12 | 5/8 | -12 | 16.0 | 1 1/16x12 | 3/4 | 87 | 63 | 21 | 1 1/4 |
| 13726-16-16 | 7/8 | -16 | 22.0 | 1 5/16x12 | 1 | 85 | 58 | 23 | 1 1/2 |

Approved **fitting series** for hose types:

BA: Nipple: Brass, Nut and Shell: Steel

26 201 206 213 221FR 244 285 293



B2b-4

Catalogue 4400/UK

39 Female JIC 37° – Swivel 90° Elbow

ISO 12151-5-SWES – DKJ 90°

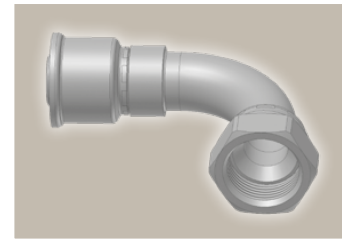
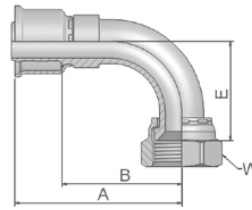

| Part Number | Hose I.D. | | | Thread UNF | Tube mm | A mm | B mm | E mm | W mm |
|-------------|-----------|------|------|---------------|------------|---------|---------|---------|---------|
| | Inch | Size | mm | | | | | | |
| 13926-4-4 | 3/16 | -4 | 5.0 | 7/16x20 | - | 46 | 24 | 21 | 9/16 |
| 13926-6-6 | 5/16 | -6 | 8.0 | 9/16x18 | 3/8 | 55 | 24 | 21 | 9/16 |
| 13926-8-8 | 13/32 | -8 | 10.0 | 3/4x16 | - | 56 | 35 | 28 | 7/8 |
| 13926-10-10 | 1/2 | -10 | 12.5 | 7/8x14 | - | 57 | 33 | 32 | 1 |
| 13926-10-12 | 5/8 | -12 | 16.0 | 7/8x14 | - | 64 | 40 | 31 | 1 |
| 13926-12-12 | 5/8 | -12 | 16.0 | 1 1/16x12 | - | 58 | 34 | 46 | 1 1/4 |
| 13926-16-16 | 7/8 | -16 | 22.0 | 1 5/16x12 | 1 | 84 | 57 | 54 | 1 1/2 |
| 13926-20-20 | 1 1/8 | -20 | 29.0 | 1 5/8x12 | 1 1/4 | 91 | 67 | 65 | 2 |

26 Series

Approved **fitting series** for hose types:





26 201 206 213 221FR 244 285 293

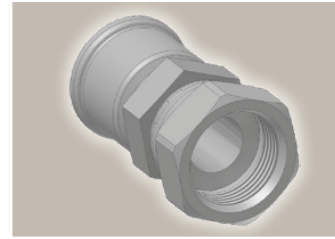
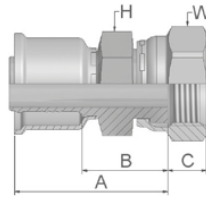

JC **Female ORFS
Swivel – Straight
Short**

ISO 12151-1 – SWSA
SAE J516 – ORFS



| Part Number |  Hose I.D. | | |  Thread UNF | A mm | B mm | C mm |  H mm |  W mm |
|-------------|------------------------------------------------------------------------------------------------|------|------|----------------------------------------------------------------------------------------------------|---------|---------|---------|------------------------------------------------------------------------------------------------|------------------------------------------------------------------------------------------------|
| | Inch | Size | mm | | | | | | |
| 1JC26-4-4 | 3/16 | -4 | 5.0 | 9/16x18 | 42 | 20 | 8 | - | 11/16 |
| 1JC26-6-6 | 5/16 | -6 | 8.0 | 11/16x16 | 43 | 21 | 9 | - | 13/16 |
| 1JC26-8-8 | 13/32 | -8 | 10.0 | 13/16x16 | 45 | 23 | 11 | - | 15/16 |
| 1JC26-10-10 | 1/2 | -10 | 12.5 | 1x14 | 55 | 31 | 13 | 15/16 | 1 1/8 |
| 1JC26-12-12 | 5/8 | -12 | 16.0 | 1 3/16x12 | 54 | 30 | 14 | - | 1 3/8 |
| 1JC26-16-16 | 7/8 | -16 | 22.0 | 1 7/16x12 | 61 | 34 | 14 | 1 3/8 | 1 5/8 |
| 1JC26-20-20 | 1 1/8 | -20 | 29.0 | 1 11/16x12 | 62 | 35 | 15 | 1 7/8 | 1 7/8 |

Approved **fitting series** for hose types:

| | | | | | | | |
|-----------|-----|-----|-----|-------|-----|-----|-----|
| 26 | 201 | 206 | 213 | 221FR | 244 | 285 | 293 |
|-----------|-----|-----|-----|-------|-----|-----|-----|



B2b-6

Catalogue 4400/UK

5S Female Tube O-ring Swivel Short Pilot

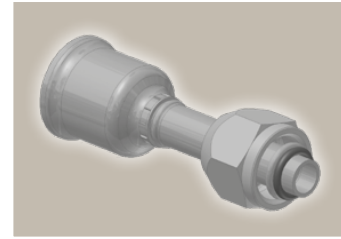
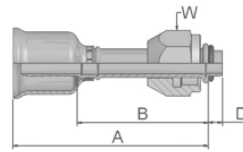

| Part Number | Hose I.D. | | | Thread UNF | A mm | B mm | D mm | W Inch |
|-------------|-----------|------|------|---------------|---------|---------|---------|-----------|
| | Inch | Size | mm | | | | | |
| 15S26-6-6 | 5/16 | -6 | 8.0 | 5/8x18 | 66 | 44 | 4.7 | 3/4 |
| 15S26-8-8 | 13/32 | -8 | 10.0 | 3/4x16 | 67 | 45 | 4.7 | 7/8 |
| 15S26-10-10 | 1/2 | -10 | 12.5 | 7/8x14 | 71 | 47 | 4.7 | 1 1/16 |
| 15S26-10-12 | 5/8 | -12 | 16.0 | 7/8x14 | 71 | 47 | 4.7 | 1 1/16 |

26 Series

5T Female Tube O-Ring Swivel 90° Elbow – Short Pilot

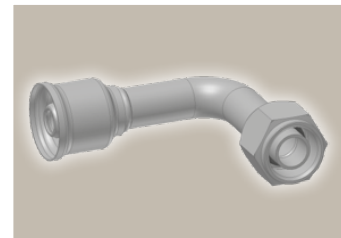
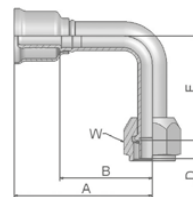

| Part Number | Hose I.D. | | | Thread UNF | A mm | B mm | D mm | E mm | W Inch |
|-------------|-----------|------|------|---------------|---------|---------|---------|---------|-----------|
| | Inch | Size | mm | | | | | | |
| 15T26-6-6 | 5/16 | -6 | 8.0 | 5/8x18 | 56 | 34 | 4.7 | 36 | 3/4 |
| 15T26-8-8 | 13/32 | -8 | 10.0 | 3/4x16 | 63 | 41 | 4.7 | 37 | 7/8 |
| 15T26-10-10 | 1/2 | -10 | 12.5 | 7/8x14 | 73 | 49 | 4.7 | 44 | 1 1/16 |

Approved **fitting series** for hose types:

26 201 206 213 221FR 244 285 293



B2b-7

Catalogue 4400/UK



Hydraulic Hoses and Fittings

Medium Pressure



ENGINEERING YOUR SUCCESS.

Medium Pressure Hoses and Fittings

The perfect range for the more demanding market requirements

This medium pressure hose range contains the Elite No-Skive compact hydraulic hoses exceeding ISO and EN specifications and the classic No-Skive hydraulic hoses according to ISO, EN and SAE specifications. This hose range is complemented by a full selection of compatible No-Skive fittings in steel and stainless steel.



- **Extended range** of working temperatures:
-50 °C up to +150 °C
- Selected hoses feature **nitrile inner tubes** suitable for mineral and bio-degradable oils
- Full range of **fluid compatibility**; oil, water, phosphate ester etc.

- Using **high quality compounds** allows thin covers – less weight – long service life still assured
- **High flexibility** for easier installation and increased service life
- **Small bend radii** and **light weight** for applications where space and weight are determining factors
- High **abrasion resistance** hose covers superior to ISO 6945 requirements, extending service life
- High **ozone-resistant** cover compounds extending weathering and ageing resistance
- **Parkrimp** machines, portable or bench mount for easy assembly operation – hose assemblies meet CE directives
- Complete **No-Skive fitting technology** across the full range of medium pressure hoses providing simpler, quicker and safer hose assembly



Applications

The definitive hose range for all medium-pressure applications



C-2

Parkrimp® *No-Skive*

The system for fast and leak-free assemblies

The perfect match



The complete system from one source. No-Skive hose, No-Skive fitting and crimping machine with world-wide guarantee and availability.

Parker's colour-coded die sets



No loose parts to mismatch or misplace – die set segments linked together.

Die sets provide 360° evenly applied crimping forces for an ideal crimp result.

Parkalign®



Parker's exclusive Parkalign® positions the fitting in the dies perfectly every time.



KarryKrimp® 1

KarryKrimp® 2

Parkrimp®

KarryKrimp® 2 Bench Mount



Parkrimp® *No-Skive*

- No skiving tool needed
- No need to remove the cover
- Crimps one-piece fittings
- Parkalign positions the fittings in the dies perfectly every time
- Quick and easy: no gauges to set on the machine
- Portable machines for field repair
- Meets EN safety regulations

Good – Better – Best – engineered for your success.

New classification for easier hose and fitting selection

Good

“Good” hoses are cost-effective products – fully meeting the main parameters of the traditional international standards and exceeding them in particular requirements, such as service life, appearance, environmental aspects etc. (BCH braided hoses in combination with fitting series 46 and 48 and in the high pressure range SX spiral hoses with fittings series 73 and 77).

Better

The category “Better” includes hose products which are exceeding the traditional international standards in the main parameters, such as working pressure, temperature, flexibility, impulse pressure resistance etc. These are the main qualities appreciated by the customers at the Parker well known *No-Skive* hoses – *Elite* braided and in the high pressure range Parkrimp spiral.

Best

Category “Best” contains GLOBALCORE™ hose products which are meeting or even exceeding the latest and most demanding International Standard ISO 18752. GLOBALCORE™ is the world’s first high performance, cohesive hose and fitting range. GLOBALCORE™ hoses have constant working pressures of 21.0 or 28.0 MPa and in the high pressure range 35.0 or 42.0 MPa.

Good Medium Pressure

BCH1, BCH2

Fitting Series



Better Medium Pressure

Elite 462, 492

Fitting Series



Best Medium Pressure

GLOBALCORE™ 387, 487

Fitting Series



Good

Newly developed high performance *No-Skive* hoses

BCH braided hoses – meeting international technical standards, newly developed for demanding small and medium OEMs and general distribution.

BCH1

EN 857 1SC - ISO 11237



Size -4 up to -16
-40 °C up to +100 °C
Working pressure up to 22.5 MPa



NO-SKIVE BCH1-6 WP 18.0 MPa (2610 PSI) | •• 10 mm

BCH2

EN 857 2SC - ISO 11237



Size -4 up to -16
-40 °C up to +100 °C
Working pressure up to 40.0 MPa



NO-SKIVE BCH2-6 WP 33 MPa (4800 PSI) | •• 10 mm

Customers choice is the key

Good, Better, Best classification for easier hose and fitting selection

- Different levels for different markets and applications
- Help customers to make better buying decision
- Defined hose and fitting combination on hose layline
- Clear visibility of correct fitting
- Easy to understand
- Ensures quality of hose and fitting combination

Superior performance of Best hoses versus Better and Good hoses

- Bend radius up to 50% smaller
- Flexibility (bending force) up to 30% higher
- Weight up to 20% lower
- Dimensions up to 25% smaller area
- Impulse resistance and service life up to four times higher
- Working temperature up to 25% higher

Agriculture is one of the typical markets and applications where „Good hose and fittings“ are the preferred product selection.



Elite No-Skive Hoses

for reliability, performance, sustainability and prevention

Designers of hydraulic machinery are increasingly defining new products that require hydraulic circuits with tighter curves, higher pressures and less space in which to route flexible connections and achieve a solution.

The option to use flexible connections that are tested over and above the generally accepted norms and specifications and, that offer reliability and performance to the highest market standards, give peace of mind and the possibility to enhance the reputation and dependability of products developed by engineering and design departments. To meet hydraulic application demands for reliability and performance, engineers typically look at medium pressure braided hose ranges with a compact design and no-skive fittings. They often tend towards well known and established names on the market, where real-world long life and dependability have been proven.

Reliability

One of the most important factors engineers look for is reliability. In the case of a hydraulic hose line that primarily means the integrity of its connection. Hoses that use the Parker® No-Skive technology, such as the Elite range from Parker, are the preferred choice for all medium pressure mobile and industrial applications.



Leakfree No-Skive hose assembly

Performance

Particularly challenging are applications in earth-moving and construction machinery that require higher performance from the hoses they use in terms of flexibility, a tight bending radius and resistance to very low temperatures. The Elite low temperature hose 461LT can be used in applications with an ambient temperature of down to -50 °C.



Low temperature hose 461LT

Sustainability

Sustainability is a strategy that underlines many initiatives, integrating life cycles assessment into the product development process for leading, responsible manufacturers. Transparency in the use of chemicals, processes and materials and utilising technical know-how and engineering skills are key to meet this increasingly important and globally relevant requirements.



Elite No-Skive Hoses

with outstanding technical properties



Chrome6-free fittings

Prevention

High performance most often goes hand-in-hand with long life and reliability which translates into reduced machine downtime caused by hose assembly failure. However, through a preventive maintenance program, unexpected, unscheduled and costly downtime can be largely avoided. A Preventive Maintenance Program may comprise regular checks of the hydraulic circuit and of all the flexible parts that compose it. Identification systems such as the Parker Tracking System (PTS) are designed to help customers reduce vehicle or asset downtime through increases in speed, timing and accuracy of necessary repairs.

The wire braided Elite No-Skive hose range with outstanding technical properties such as superior flexibility, tighter bend radii and tough or super tough hose cover exceeds the EN specifications and meets the OEM and MRO requirements of today and tomorrow! The range also includes a new chlorine-free hose type with a smooth pure nitrile inner tube – a hose which is environmentally friendly from production to disposal and that with an excellent chemical resistance.



Exceeds European specifications

- higher abrasion resistance
- higher pressure ratings



Long service life achieved through implementing

- nitrile inner tubes for better fluid compatibility
- tested and approved hose and fitting combinations



innovative product line with excellent technical characteristics

- high flexibility
- tight bending radii
- compact thin cover hoses
- No-Skive technology

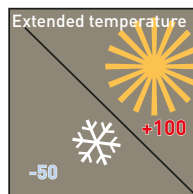

temperature range

- up to +125 °C
- down to -50 °C for low temperature (LT) hoses

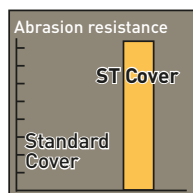

extreme abrasion resistance

- > 1 Mio cycles with ST cover according to ISO 6945 (which represents 450 times the standard cover)

GLOBALCORE™

The world's first high-performance, cohesive hose and fitting system

187 / 187TC / 187ST *No-Skive* GlobalCore

Meeting the demands of complex hydraulic systems and high pressure return lines

Primary Applications



Parker's GlobalCore 187 hose provides 7 MPa (1,000 psi) constant working pressure in all sizes. Available in a variety of cover options so you can match the right cover to your application, 187 hose offers you the choice of Standard, ToughCover and SuperTough.

Designed, built and tested to the ISO 18752 performance specification, Parker's 187 hose is unmatched in today's marketplace.

For high pressure return line applications in all markets.

387 / 387TC / 387ST *No-Skive* GlobalCore

Delivering value and performance for high-pressure systems

Primary Applications



Parker's GlobalCore 387 hose provides 21 MPa (3,000 psi) constant working pressure in all sizes. Available in a variety of cover options so you can match the right cover to your application, 387 hose offers you the choice of Standard, ToughCover and SuperTough. Designed, built and tested to the ISO 18752 performance specification, Parker's 387 hose is unmatched in today's marketplace.

487 / 487TC / 487ST *No-Skive* GlobalCore

Highly flexible across all sizes

Primary Applications

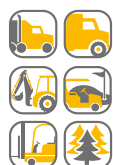

Parker's GlobalCore 487 hose provides 28 MPa (4,000 psi) constant working pressure in all sizes. Designed for high performance, 487 is available in a variety of cover options, including Standard, ToughCover and SuperTough. Its synthetic rubber inner tube provides a wider range of fluid compatibility. Rated to the ISO 18752 performance specification, 487 will excel in multiple applications around the world.



www.parker.com/globalcore

GlobalCore significantly reduces system complexity



- 7 MPa (1,000 psi) constant working pressure
- Exceeds ISO 18752 performance specification (AS)
- Synthetic rubber inner tube provides a wider range of fluid compatibility
- TC cover provides 80 times the abrasion resistance compared to Standard rubber cover hoses
- ST cover provides 450 times the abrasion resistance compared to Standard rubber cover hoses



- ½ ISO 18752 minimum bend radius
- Low force to flex for ease of installation
- 21 MPa (3,000 psi) constant working pressure in all sizes
- Exceeds ISO 18752 performance specification (AC, BC and CC)
- Synthetic rubber inner tube provides a wider range of fluid compatibility
- TC cover provides 80 times the abrasion resistance compared to Standard rubber cover hose
- ST cover provides 450 times the abrasion resistance compared to Standard rubber cover hose



- ½ ISO 18752 minimum bend radius
- Low force to flex for ease of installation
- 28 MPa (4,000 psi) constant working pressure in all sizes
- Exceeds ISO 18752 performance specification (AC, BC & CC)
- TC cover provides 80 times the abrasion resistance compared to Standard rubber cover hose
- ST cover provides 450 times the abrasion resistance compared to Standard rubber cover hose

Universal Push-to-Connect (UPTC)

The unique push-in system for tubes and hoses

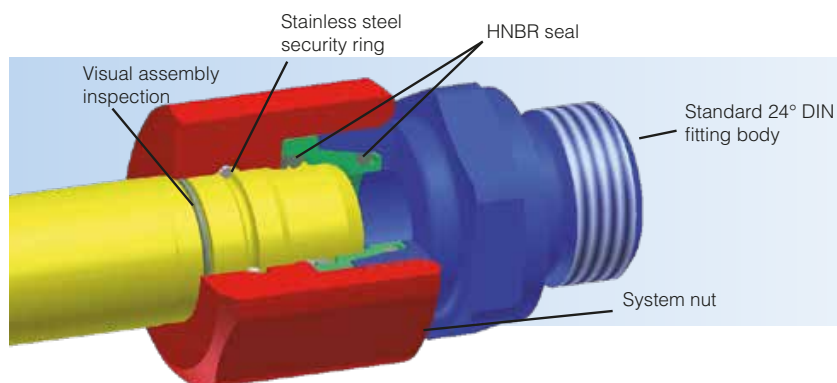

As a standard solution it's a stroke of genius

Parker's UPTC is the standardised push-in system for Parker 24° DIN fitting bodies.

In use with tube and hose

Because of its flexibility, UPTC is a unique push-in system for tube and hose terminations.

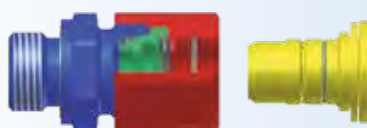
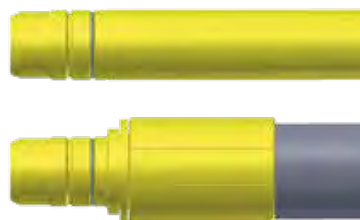

Assembly

- Simply introduce the hose or tube into the works-assembled fitting and push in.



Assembled connector

Simple

- Visual assembly inspection
- Marker inside the nut = unambiguous assembly results

Safe

- Security ring locks in place
- Termination is held in the connector

Leak-proof

- Elastomeric seal
- 100 % leak-proof

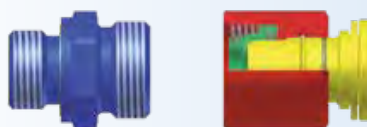

Disassembly

- Removable and fit for reassembly just like conventional screw fittings – possible even in very dirty conditions

- Repair-friendly
- No special tools required

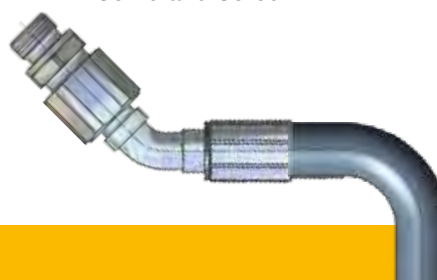
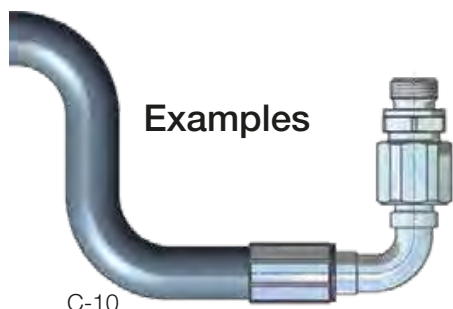

For more information about UPTC please refer to pages Cc-49 and Cc-50

Medium Pressure GLOBALCORE™

| Hoses | | | Page |
|-------------|--------------|------------|-------|
| Best | 187 | GlobalCore | Caa-1 |
| Best | 187TC | GlobalCore | Caa-2 |
| Best | 187ST | GlobalCore | Caa-3 |
| Best | 387 | GlobalCore | Caa-4 |
| Best | 387TC | GlobalCore | Caa-5 |
| Best | 387ST | GlobalCore | Caa-6 |
| Best | 487 | GlobalCore | Caa-7 |
| Best | 487TC | GlobalCore | Caa-8 |
| Best | 487ST | GlobalCore | Caa-9 |

Index

| Fittings Series | 43 | 46/48 |
|---------------------|---------|---------|
| Chapter | Cc | Cd |
| DIN – Metric | 1 – 4 | 1 – 9 |
| BSP | 5 – 8 | 10 – 18 |
| SAE | 9 – 10 | 19 – 24 |
| Flange | 12 – 13 | 25 – 29 |
| ORFS | 14 – 15 | 30 – 35 |
| JIS | | 36 – 37 |
| Others | | 40 |
| UPTC | | 41 – 42 |

Parker Hannifin assumes no liability for typographical errors or other errors



Standard

| | | |
|------------------------------------------------------------------------------------------------------------------------------------------------------------------------------------------------------------------------------------------------|--------------------------------------------------------------------------------------------------------------------------------------------------------------------------------------------------------------------------------------------------------------------------------------------------------|---------------------------------------------------------------------------------------------------------------------------------------------------------------------------------------------------------------------------------------------------------------------------------------------------------|
| <p>187 Best</p> <p>Caa-1 </p> <p><i>No-Skive GlobalCore</i> Exceeds ISO 18752-AS</p> | <p>387 Best</p> <p>Caa-4 </p> <p><i>No-Skive GlobalCore</i> Sizes -4 to -16 exceed ISO 18752-AC Sizes -20 to -32 exceed ISO 18752-BC</p> | <p>487 Best</p> <p>Caa-7 </p> <p><i>No-Skive GlobalCore</i> Sizes -4 to -12 exceed ISO 18752-AC Sizes -16 to -32 exceed ISO 18752-BC</p> |
|------------------------------------------------------------------------------------------------------------------------------------------------------------------------------------------------------------------------------------------------|--------------------------------------------------------------------------------------------------------------------------------------------------------------------------------------------------------------------------------------------------------------------------------------------------------|---------------------------------------------------------------------------------------------------------------------------------------------------------------------------------------------------------------------------------------------------------------------------------------------------------|

High abrasion resistance

| | | |
|--------------------------------------------------------------------------------------------------------------------------------------------------------------------------------------------------------------------------------------------------------------|----------------------------------------------------------------------------------------------------------------------------------------------------------------------------------------------------------------------------------------------------------------------------------------------------------------------|-----------------------------------------------------------------------------------------------------------------------------------------------------------------------------------------------------------------------------------------------------------------------------------------------------------------------|
| <p>187TC Best</p> <p>Caa-2 </p> <p><i>No-Skive GlobalCore Tough Cover</i> Exceeds ISO 18752-AS</p> | <p>387TC Best</p> <p>Caa-5 </p> <p><i>No-Skive GlobalCore Tough Cover</i> Sizes -4 to -16 exceed ISO 18752-AC Sizes -20 to -32 exceed ISO 18752-CC</p> | <p>487TC Best</p> <p>Caa-8 </p> <p><i>No-Skive GlobalCore Tough Cover</i> Sizes -4 to -12 exceed ISO 18752-AC Sizes -16 to -32 exceed ISO 18752-CC</p> |
|--------------------------------------------------------------------------------------------------------------------------------------------------------------------------------------------------------------------------------------------------------------|----------------------------------------------------------------------------------------------------------------------------------------------------------------------------------------------------------------------------------------------------------------------------------------------------------------------|-----------------------------------------------------------------------------------------------------------------------------------------------------------------------------------------------------------------------------------------------------------------------------------------------------------------------|

Extreme abrasion resistance

| | | |
|--------------------------------------------------------------------------------------------------------------------------------------------------------------------------------------------------------------------------------------------------------------|----------------------------------------------------------------------------------------------------------------------------------------------------------------------------------------------------------------------------------------------------------------------------------------------------------------------|-----------------------------------------------------------------------------------------------------------------------------------------------------------------------------------------------------------------------------------------------------------------------------------------------------------------------|
| <p>187ST Best</p> <p>Caa-3 </p> <p><i>No-Skive GlobalCore Super Tough</i> Exceeds ISO 18752-AS</p> | <p>387ST Best</p> <p>Caa-6 </p> <p><i>No-Skive GlobalCore Super Tough</i> Sizes -4 to -16 exceed ISO 18752-AC Sizes -20 to -32 exceed ISO 18752-CC</p> | <p>487ST Best</p> <p>Caa-9 </p> <p><i>No-Skive GlobalCore Super Tough</i> Sizes -4 to -12 exceed ISO 18752-AC Sizes -16 to -32 exceed ISO 18752-CC</p> |
|--------------------------------------------------------------------------------------------------------------------------------------------------------------------------------------------------------------------------------------------------------------|----------------------------------------------------------------------------------------------------------------------------------------------------------------------------------------------------------------------------------------------------------------------------------------------------------------------|-----------------------------------------------------------------------------------------------------------------------------------------------------------------------------------------------------------------------------------------------------------------------------------------------------------------------|

187

No-Skive GlobalCore

Exceeds ISO 18752-AS

Primary Applications

Designed, build and tested to the ISO 18752 performance specifications. For high pressure return line applications in all markets.

Applicable Specifications

ISO 18752-AS

Construction

Inner tube: Synthetic rubber
Reinforcement: Two high-tensile steel wire braids
Cover: Synthetic rubber

Temperature Range -40 °C up to +100 °C

Exception: Air max. +70 °C

Water max. +85 °C

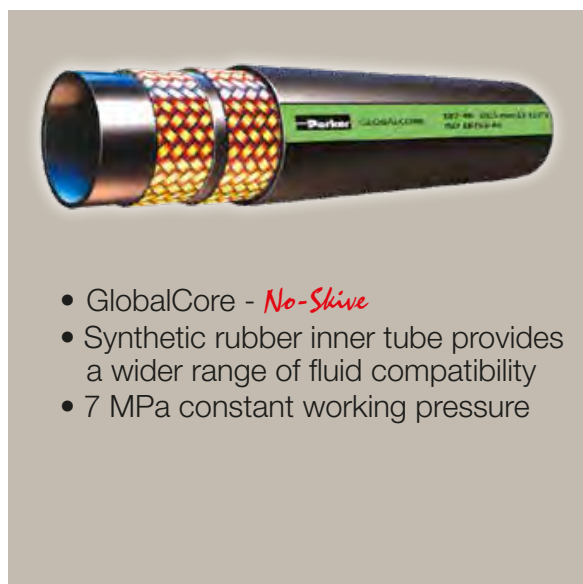

- GlobalCore - *No-Skive*
- Synthetic rubber inner tube provides a wider range of fluid compatibility
- 7 MPa constant working pressure

Recommended Fluids

Hydraulic fluids on a mineral-oil basis, water-glycol and lubricating oils, air and water. For air and gas applications with a pressure exceeding 1.7 MPa, the cover must be pin-pricked. Consult the chemical compatibility section on pages **Ab-26** to **Ab-34** for more detailed information.

Fitting Series

Series 43/48 for sizes -8 to -32



Series 48 2piece for sizes -40 to -48



GLOBALCORE

| Part Number | Hose I.D. | | | | Hose O.D. mm | Pressure Rating | | | | Vacuum* kPa | min. bend radius mm | weight kg |
|-------------|-----------|-------|------|------|-----------------|-----------------------|------|---------------------|------|----------------|------------------------|--------------|
| | DN | Inch | Size | mm | | max. working pressure | | min. burst pressure | | | | |
| | | | | | | MPa | psi | MPa | psi | | | |
| 187-8 | 12 | 1/2 | -8 | 12.7 | 21.0 | 7.0 | 1000 | 28.0 | 4000 | 80 | 65 | 0.43 |
| 187-10 | 16 | 5/8 | -10 | 15.9 | 24.0 | 7.0 | 1000 | 28.0 | 4000 | 80 | 75 | 0.49 |
| 187-12 | 19 | 3/4 | -12 | 19.1 | 27.0 | 7.0 | 1000 | 28.0 | 4000 | 80 | 90 | 0.63 |
| 187-16 | 25 | 1 | -16 | 25.4 | 36.0 | 7.0 | 1000 | 28.0 | 4000 | 80 | 114 | 0.91 |
| 187-20 | 31 | 1 1/4 | -20 | 31.8 | 44.0 | 7.0 | 1000 | 28.0 | 4000 | 80 | 140 | 1.85 |
| 187-24 | 38 | 1 1/2 | -24 | 38.1 | 52.0 | 7.0 | 1000 | 28.0 | 4000 | 80 | 248 | 1.96 |
| 187-32 | 51 | 1 | -32 | 50.8 | 65.0 | 7.0 | 1000 | 28.0 | 4000 | 80 | 318 | 2.60 |
| 187-40 | 63 | 2 1/2 | -40 | 63.5 | 75.0 | 7.0 | 1000 | 28.0 | 4000 | 80 | 508 | 3.04 |
| 187-48 | 76 | 3 | -48 | 76.2 | 91.0 | 7.0 | 1000 | 28.0 | 4000 | 80 | 508 | 4.12 |

The combination of high temperature and high pressure could reduce the hose life.

Hose layline example



Medium Pressure GLOBALCORE
High abrasion resistance

Parkrimp No-Skive Hose
187TC

187TC

No-Skive GlobalCore Tough Cover
Exceeds ISO 18752-AS

Primary Applications

Designed, build and tested to the ISO 18752 performance specifications. For high pressure return line applications in all markets.

Applicable Specifications
ISO 18752-AS

Construction

Inner tube: Synthetic rubber
Reinforcement: Two high-tensile steel wire braids
Cover: Highly abrasion resistance
MSHA approved synthetic rubber

Temperature Range -40 °C up to +125 °C
For -40 & -48 sizes -40 °C up to +100 °C
Exception: Air max. +70 °C
Water max. +85 °C

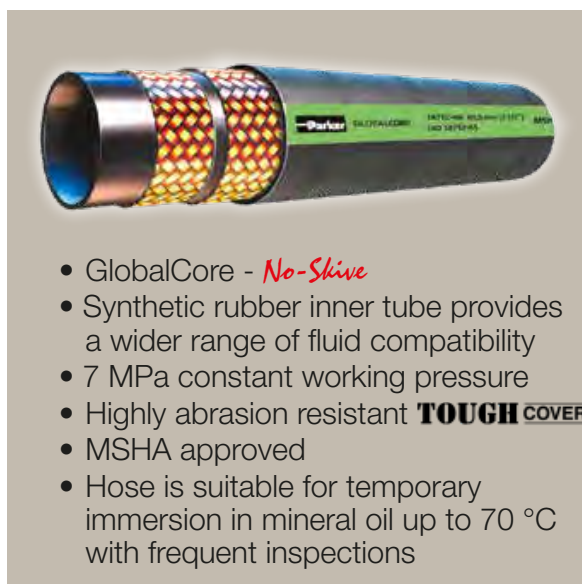

- GlobalCore - *No-Skive*
- Synthetic rubber inner tube provides a wider range of fluid compatibility
- 7 MPa constant working pressure
- Highly abrasion resistant **TOUGH COVER**
- MSHA approved
- Hose is suitable for temporary immersion in mineral oil up to 70 °C with frequent inspections

Recommended Fluids

Hydraulic fluids on a mineral-oil basis, water-glycol and lubricating oils, air and water. For air and gas applications with a pressure exceeding 1.7 MPa, the cover must be pin-pricked. Consult the chemical compatibility section on pages **Ab-26** to **Ab-34** for more detailed information.

Fitting Series

Series 43/48 for sizes -8 to -32



Series 48 2piece for sizes -40 to -48



| Part Number | Hose I.D. | | | | Hose O.D. mm | Pressure Rating | | | | Vacuum* kPa | min. bend radius mm | weight kg |
|-------------|-----------|-------|------|------|-----------------|------------------------------|------|----------------------------|------|----------------|------------------------|--------------|
| | DN | Inch | Size | mm | | max. working pressure MPa | psi | min. burst pressure MPa | psi | | | |
| 187TC-8 | 12 | 1/2 | -8 | 12.7 | 21.0 | 7.0 | 1000 | 28.0 | 4000 | 80 | 65 | 0.43 |
| 187TC-10 | 16 | 5/8 | -10 | 15.9 | 24.0 | 7.0 | 1000 | 28.0 | 4000 | 80 | 75 | 0.49 |
| 187TC-12 | 19 | 3/4 | -12 | 19.1 | 27.0 | 7.0 | 1000 | 28.0 | 4000 | 80 | 90 | 0.63 |
| 187TC-16 | 25 | 1 | -16 | 25.4 | 36.0 | 7.0 | 1000 | 28.0 | 4000 | 80 | 114 | 0.91 |
| 187TC-20 | 31 | 1 1/4 | -20 | 31.8 | 44.0 | 7.0 | 1000 | 28.0 | 4000 | 80 | 140 | 1.85 |
| 187TC-24 | 38 | 1 1/2 | -24 | 38.1 | 52.0 | 7.0 | 1000 | 28.0 | 4000 | 80 | 248 | 1.96 |
| 187TC-32 | 51 | 1 | -32 | 50.8 | 65.0 | 7.0 | 1000 | 28.0 | 4000 | 80 | 318 | 2.60 |
| 187TC-40 | 63 | 2 1/2 | -40 | 63.5 | 75.0 | 7.0 | 1000 | 28.0 | 4000 | 80 | 508 | 3.04 |
| 187TC-48 | 76 | 3 | -48 | 76.2 | 91.0 | 7.0 | 1000 | 28.0 | 4000 | 80 | 508 | 4.12 |

The combination of high temperature and high pressure could reduce the hose life.

Hose layline example



187ST

No-Skive GlobalCore Super Tough
Exceeds ISO 18752-AS



- GlobalCore - *No-Skive*
- Synthetic rubber inner tube provides a wider range of fluid compatibility
- 7 MPa constant working pressure
- Extreme abrasion resistant **SUPER TOUGH** cover
- MSHA approved

Primary Applications

Designed, build and tested to the ISO 18752 performance specifications. For high pressure return line applications in all markets.

Applicable Specifications

ISO 18752-AS

Construction

Inner tube: Synthetic rubber
Reinforcement: Two high-tensile steel wire braids
Cover: Synthetic rubber with a special polyethylene coating

Temperature Range -40 °C up to +125 °C

For -40 & -48 sizes -40 °C up to +100 °C

Exception: Air max. +70 °C

Water max. +85 °C

Recommended Fluids

Hydraulic fluids on a mineral-oil basis, water-glycol and lubricating oils, air and water. For air and gas applications with a pressure exceeding 1.7 MPa, the cover must be pin-pricked. Consult the chemical compatibility section on pages **Ab-26** to **Ab-34** for more detailed information.

Fitting Series

Series 43/48 for sizes -8 to -32



Series 48 2piece for sizes -40 to -48

| Part Number | Hose I.D. | | | | Hose O.D. mm | Pressure Rating | | | | Vacuum* kPa | min. bend radius mm | weight kg |
|-------------|-----------|-------|------|------|-----------------|------------------------------|------|----------------------------|------|----------------|------------------------|--------------|
| | DN | Inch | Size | mm | | max. working pressure MPa | psi | min. burst pressure MPa | psi | | | |
| 187ST-8 | 12 | 1/2 | -8 | 12.7 | 21.0 | 7.0 | 1000 | 28.0 | 4000 | 80 | 65 | 0.43 |
| 187ST-10 | 16 | 5/8 | -10 | 15.9 | 24.0 | 7.0 | 1000 | 28.0 | 4000 | 80 | 75 | 0.49 |
| 187ST-12 | 19 | 3/4 | -12 | 19.1 | 27.0 | 7.0 | 1000 | 28.0 | 4000 | 80 | 90 | 0.63 |
| 187ST-16 | 25 | 1 | -16 | 25.4 | 36.0 | 7.0 | 1000 | 28.0 | 4000 | 80 | 114 | 0.91 |
| 187ST-20 | 31 | 1 1/4 | -20 | 31.8 | 44.0 | 7.0 | 1000 | 28.0 | 4000 | 80 | 140 | 1.85 |
| 187ST-24 | 38 | 1 1/2 | -24 | 38.1 | 52.0 | 7.0 | 1000 | 28.0 | 4000 | 80 | 248 | 1.96 |
| 187ST-32 | 51 | 1 | -32 | 50.8 | 65.0 | 7.0 | 1000 | 28.0 | 4000 | 80 | 318 | 2.60 |
| 187ST-40 | 63 | 2 1/2 | -40 | 63.5 | 75.0 | 7.0 | 1000 | 28.0 | 4000 | 80 | 508 | 3.04 |
| 187ST-48 | 76 | 3 | -48 | 76.2 | 91.0 | 7.0 | 1000 | 28.0 | 4000 | 80 | 508 | 4.12 |

The combination of high temperature and high pressure could reduce the hose life.

Hose layline example



387

No-Skive GlobalCore

Sizes -4 to -16 exceed ISO 18752-AC
Sizes -20 to -32 exceed ISO 18752-BC

Primary Applications

General medium pressure hydraulic applications

Applicable Specifications

Exceed ISO 18752-AC and ISO 18752-BC

Construction

- Inner tube: Synthetic rubber
- Reinforcement: One or two high-tensile steel wire braids (four-spiral for sizes -20 up to -32)
- Cover: Synthetic rubber

Temperature Range -40 °C up to +100 °C

Exception: Air max. +70 °C
Water max. +85 °C







- GlobalCore - *No-Skive*
- ½ ISO 18752 minimum bend radius
- Low force to flex for ease of installation
- 21 MPa constant working pressure

Recommended Fluids

Hydraulic fluids on a mineral-oil basis, water-glycol and lubricating oils, air and water. For air and gas applications with a pressure exceeding 1.7 MPa, the cover must be pin-pricked. Consult the chemical compatibility section on pages **Ab-26** to **Ab-34** for more detailed information.

Fitting Series

- Series 43/48 for sizes -4 up to -16  
- Series 43/77 for size -20  
- Series 77 for sizes -24 up to -32 

| Part Number | Hose I.D. | | | | Hose O.D. mm | Pressure Rating | | | | min. bend radius mm | weight kg |
|-------------|-----------|-------|------|------|-----------------|------------------------------|------|----------------------------|-------|------------------------|--------------|
| | DN | Inch | Size | mm | | max. working pressure MPa | psi | min. burst pressure MPa | psi | | |
| 387-4 | 6 | 1/4 | -4 | 6.4 | 13.4 | 21.0 | 3000 | 84.0 | 12000 | 50 | 0.24 |
| 387-6 | 10 | 3/8 | -6 | 9.5 | 17.4 | 21.0 | 3000 | 84.0 | 12000 | 65 | 0.34 |
| 387-8 | 12 | 1/2 | -8 | 12.7 | 20.7 | 21.0 | 3000 | 84.0 | 12000 | 90 | 0.43 |
| 387-10 | 16 | 5/8 | -10 | 15.9 | 23.9 | 21.0 | 3000 | 84.0 | 12000 | 100 | 0.49 |
| 387-12 | 19 | 3/4 | -12 | 19.1 | 27.8 | 21.0 | 3000 | 84.0 | 12000 | 120 | 0.86 |
| 387-16 | 25 | 1 | -16 | 25.4 | 35.4 | 21.0 | 3000 | 84.0 | 12000 | 150 | 1.17 |
| 387-20 | 31 | 1 1/4 | -20 | 31.8 | 46.3 | 21.0 | 3000 | 84.0 | 12000 | 210 | 2.59 |
| 387-24 | 38 | 1 1/2 | -24 | 38.1 | 52.8 | 21.0 | 3000 | 84.0 | 12000 | 250 | 2.99 |
| 387-32 | 51 | 2 | -32 | 50.8 | 66.2 | 21.0 | 3000 | 84.0 | 12000 | 320 | 4.09 |

The combination of high temperature and high pressure could reduce the hose life.

Hose layline example

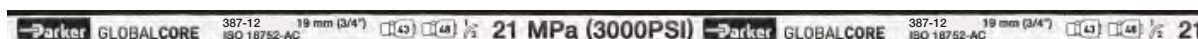

387TC

No-Skive GlobalCore Tough Cover

Sizes -4 to -16 exceed ISO 18752-AC
Sizes -20 to -32 exceed ISO 18752-CC

Primary Applications

General medium pressure hydraulic applications

Applicable Specifications

Exceed ISO 18752-AC and ISO 18752-CC

Construction

Inner tube: Synthetic rubber
Reinforcement: One or two high-tensile steel wire braids (four-spiral for sizes -20 up to -32)
Cover: Highly abrasion resistance
MSHA approved synthetic rubber

Temperature Range -40 °C up to +125 °C

Exception: Air max. +70 °C

Water max. +85 °C



- GlobalCore - *No-Skive*
- ½ ISO 18752 minimum bend radius
- Low force to flex for ease of installation
- 21 MPa constant working pressure
- Highly abrasion resistant **TOUGH COVER**
- MSHA approved
- Hose is suitable for temporary immersion in mineral oil up to 70 °C with frequent inspections

Recommended Fluids

Hydraulic fluids on a mineral-oil basis, water-glycol and lubricating oils, air and water. For air and gas applications with a pressure exceeding 1.7 MPa, the cover must be pin-pricked. Consult the chemical compatibility section on pages **Ab-26** to **Ab-34** for more detailed information.

Fitting Series

Series 43/48 for sizes -4 up to -16



Series 43/77 for size -20



Series 77 for sizes -24 up to -32



| Part Number | Hose I.D. | | | | Hose O.D. mm | Pressure Rating | | | | min. bend radius mm | weight kg |
|-------------|-----------|-------|------|------|-----------------|------------------------------|------|----------------------------|-------|------------------------|--------------|
| | DN | Inch | Size | mm | | max. working pressure MPa | psi | min. burst pressure MPa | psi | | |
| 387TC-4 | 6 | 1/4 | -4 | 6.4 | 13.4 | 21.0 | 3000 | 84.0 | 12000 | 50 | 0.24 |
| 387TC-6 | 10 | 3/8 | -6 | 9.5 | 17.4 | 21.0 | 3000 | 84.0 | 12000 | 65 | 0.34 |
| 387TC-8 | 12 | 1/2 | -8 | 12.7 | 20.7 | 21.0 | 3000 | 84.0 | 12000 | 90 | 0.43 |
| 387TC-10 | 16 | 5/8 | -10 | 15.9 | 23.9 | 21.0 | 3000 | 84.0 | 12000 | 100 | 0.49 |
| 387TC-12 | 19 | 3/4 | -12 | 19.1 | 27.8 | 21.0 | 3000 | 84.0 | 12000 | 120 | 0.86 |
| 387TC-16 | 25 | 1 | -16 | 25.4 | 35.4 | 21.0 | 3000 | 84.0 | 12000 | 150 | 1.17 |
| 387TC-20 | 31 | 1 1/4 | -20 | 31.8 | 46.3 | 21.0 | 3000 | 84.0 | 12000 | 210 | 2.59 |
| 387TC-24 | 38 | 1 1/2 | -24 | 38.1 | 52.8 | 21.0 | 3000 | 84.0 | 12000 | 250 | 2.99 |
| 387TC-32 | 51 | 2 | -32 | 50.8 | 66.2 | 21.0 | 3000 | 84.0 | 12000 | 320 | 4.09 |

The combination of high temperature and high pressure could reduce the hose life.

Hose layline example



387ST

No-Skive GlobalCore Super Tough

Sizes -4 to -16 exceed ISO 18752-AC
Sizes -20 to -32 exceed ISO 18752-CC

Primary Applications

Medium pressure hydraulic applications
with extremely high abrasion risks

Applicable Specifications

Exceed ISO 18752-AC and ISO 18752-CC

Construction

Inner tube: Synthetic rubber
Reinforcement: One or two high-tensile steel wire braids
(four-spiral for sizes -20 up to -32)
Cover: Synthetic rubber
with a special polyethylene coating

Temperature Range -40 °C up to +125 °C

Exception: Air max. +70 °C
Water max. +85 °C







- GlobalCore - *No-Skive*
 - ½ ISO 18752 minimum bend radius
 - Low force to flex for ease of installation
 - 21 MPa constant working pressure
 - Extreme abrasion resistant
- SUPER TOUGH** cover

Recommended Fluids

Hydraulic fluids on a mineral-oil basis, water-glycol and lubricating oils, air and water. For air and gas applications with a pressure exceeding 1.7 MPa, the cover must be pin-pricked. Consult the chemical compatibility section on pages **Ab-26** to **Ab-34** for more detailed information.

Fitting Series

Series 43/48 for sizes -4 up to -16  
Series 43/77 for size -20  
Series 77 for sizes -24 up to -32 

| Part Number | Hose I.D. | | | | Hose O.D. mm | Pressure Rating | | | | min. bend radius mm | weight kg |
|-------------|-----------|-------|------|------|-----------------|------------------------------|------|----------------------------|-------|------------------------|--------------|
| | DN | Inch | Size | mm | | max. working pressure MPa | psi | min. burst pressure MPa | psi | | |
| 387ST-4 | 6 | 1/4 | -4 | 6.4 | 13.4 | 21.0 | 3000 | 84.0 | 12000 | 50 | 0.24 |
| 387ST-6 | 10 | 3/8 | -6 | 9.5 | 17.4 | 21.0 | 3000 | 84.0 | 12000 | 65 | 0.34 |
| 387ST-8 | 12 | 1/2 | -8 | 12.7 | 20.7 | 21.0 | 3000 | 84.0 | 12000 | 90 | 0.43 |
| 387ST-10 | 16 | 5/8 | -10 | 15.9 | 23.9 | 21.0 | 3000 | 84.0 | 12000 | 100 | 0.49 |
| 387ST-12 | 19 | 3/4 | -12 | 19.1 | 27.8 | 21.0 | 3000 | 84.0 | 12000 | 120 | 0.86 |
| 387ST-16 | 25 | 1 | -16 | 25.4 | 35.4 | 21.0 | 3000 | 84.0 | 12000 | 150 | 1.17 |
| 387ST-20 | 31 | 1 1/4 | -20 | 31.8 | 46.3 | 21.0 | 3000 | 84.0 | 12000 | 210 | 2.59 |
| 387ST-24 | 38 | 1 1/2 | -24 | 38.1 | 52.8 | 21.0 | 3000 | 84.0 | 12000 | 250 | 2.99 |
| 387ST-32 | 51 | 2 | -32 | 50.8 | 66.2 | 21.0 | 3000 | 84.0 | 12000 | 320 | 4.09 |

The combination of high temperature and high pressure could reduce the hose life.

Hose layline example

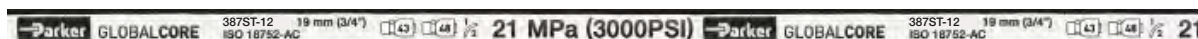

487

No-Skive GlobalCore

Sizes -4 to -12 exceed ISO 18752-AC
Sizes -16 to -32 exceed ISO 18752-BC



- GlobalCore - *No-Skive*
- ½ ISO 18752 minimum bend radius
- Low force to flex for ease of installation
- 28 MPa constant working pressure

Primary Applications

General medium pressure hydraulic applications

Applicable Specifications

Exceed ISO 18752-AC and ISO 18752-BC

Construction

- Inner tube: Synthetic rubber
 Reinforcement: One or two high-tensile steel wire braids for sizes -4 up to -12 (four-spiral wires for sizes -16 up to -24 Six-spiral wires for size -32)
 Cover: Synthetic rubber

Recommended Fluids

Hydraulic fluids on a mineral-oil basis, water-glycol and lubricating oils, air and water. For air and gas applications with a pressure exceeding 1.7 MPa, the cover must be pin-pricked. Consult the chemical compatibility section on pages **Ab-26** to **Ab-34** for more detailed information.

Fitting Series

Series 43/48 for sizes -4 up to -12

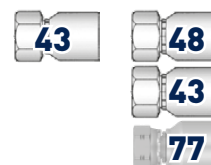

Series 43 for size -16

Series 77 for sizes -20 up to -32

Temperature Range -40 °C up to +100 °C

Exception: Air max. +70 °C
 Water max. +85 °C

| Part Number | Hose I.D. | | | | Hose O.D. mm | Pressure Rating | | | | min. bend radius mm | weight kg |
|-------------|-----------|-------|------|------|-----------------|------------------------------|------|----------------------------|-------|------------------------|--------------|
| | DN | Inch | Size | mm | | max. working pressure MPa | psi | min. burst pressure MPa | psi | | |
| 487-4 | 6 | 1/4 | -4 | 6.4 | 13.1 | 28.0 | 4000 | 112.0 | 16000 | 50 | 0.30 |
| 487-6 | 10 | 3/8 | -6 | 9.5 | 17.2 | 28.0 | 4000 | 112.0 | 16000 | 65 | 0.42 |
| 487-8 | 12 | 1/2 | -8 | 12.7 | 20.4 | 28.0 | 4000 | 112.0 | 16000 | 90 | 0.52 |
| 487-10 | 16 | 5/8 | -10 | 15.9 | 23.9 | 28.0 | 4000 | 112.0 | 16000 | 100 | 0.66 |
| 487-12 | 19 | 3/4 | -12 | 19.1 | 27.8 | 28.0 | 4000 | 112.0 | 16000 | 120 | 0.86 |
| 487-16 | 25 | 1 | -16 | 25.4 | 37.8 | 28.0 | 4000 | 112.0 | 16000 | 150 | 1.99 |
| 487-20 | 31 | 1 1/4 | -20 | 31.8 | 46.3 | 28.0 | 4000 | 112.0 | 16000 | 210 | 2.59 |
| 487-24 | 38 | 1 1/2 | -24 | 38.1 | 52.8 | 28.0 | 4000 | 112.0 | 16000 | 250 | 3.08 |
| 487-32 | 51 | 2 | -32 | 50.8 | 67.3 | 28.0 | 4000 | 112.0 | 16000 | 320 | 6.47 |

The combination of high temperature and high pressure could reduce the hose life.

Hose layline example

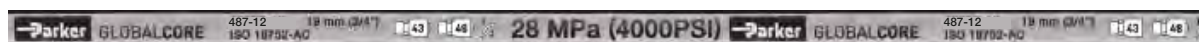

Medium Pressure GLOBALCORE
High abrasion resistance

Parkrimp No-Skive Hose
487TC

487TC

No-Skive GlobalCore Tough Cover

Sizes -4 to -12 exceed ISO 18752-AC
Sizes -16 to -32 exceed ISO 18752-CC

Primary Applications

General medium pressure hydraulic applications

Applicable Specifications

Exceed ISO 18752-AC and ISO 18752-BC

Construction

Inner tube: Synthetic rubber
Reinforcement: One or two high-tensile steel wire braids for sizes -4 up to -12 (four-spiral wires for sizes -16 up to -24 Six-spiral wires for size -32)
Cover: Highly abrasion resistance MSHA approved synthetic rubber

Temperature Range -40 °C up to +125 °C

Exception: Air max. +70 °C
Water max. +85 °C



- GlobalCore - *No-Skive*
- ½ ISO 18752 minimum bend radius
- Low force to flex for ease of installation
- 28 MPa constant working pressure
- Highly abrasion resistant **TOUGH COVER**
- MSHA approved
- Hose is suitable for temporary immersion in mineral oil up to 70 °C with frequent inspections

Recommended Fluids

Hydraulic fluids on a mineral-oil basis, water-glycol and lubricating oils, air and water. For air and gas applications with a pressure exceeding 1.7 MPa, the cover must be pin-pricked. Consult the chemical compatibility section on pages **Ab-26 to Ab-34** for more detailed information.

Fitting Series

Series 43/48 for sizes -4 up to -12  
Series 43 for size -16 
Series 77 for sizes -20 up to -32 

| Part Number | Hose I.D. | | | | Hose O.D. mm | Pressure Rating | | | | min. bend radius mm | weight kg |
|-------------|-----------|-------|------|------|-----------------|------------------------------|------|----------------------------|-------|------------------------|--------------|
| | DN | Inch | Size | mm | | max. working pressure MPa | psi | min. burst pressure MPa | psi | | |
| 487TC-4 | 6 | 1/4 | -4 | 6,4 | 13,1 | 28,0 | 4000 | 112,0 | 16000 | 50 | 0,30 |
| 487TC-6 | 10 | 3/8 | -6 | 9,5 | 17,2 | 28,0 | 4000 | 112,0 | 16000 | 65 | 0,42 |
| 487TC-8 | 12 | 1/2 | -8 | 12,7 | 20,4 | 28,0 | 4000 | 112,0 | 16000 | 90 | 0,52 |
| 487TC-10 | 16 | 5/8 | -10 | 15,9 | 23,9 | 28,0 | 4000 | 112,0 | 16000 | 100 | 0,66 |
| 487TC-12 | 19 | 3/4 | -12 | 19,1 | 27,8 | 28,0 | 4000 | 112,0 | 16000 | 120 | 0,86 |
| 487TC-16 | 25 | 1 | -16 | 25,4 | 37,8 | 28,0 | 4000 | 112,0 | 16000 | 150 | 1,99 |
| 487TC-20 | 31 | 1 1/4 | -20 | 31,8 | 46,3 | 28,0 | 4000 | 112,0 | 16000 | 210 | 2,59 |
| 487TC-24 | 38 | 1 1/2 | -24 | 38,1 | 52,8 | 28,0 | 4000 | 112,0 | 16000 | 250 | 3,08 |
| 487TC-32 | 51 | 2 | -32 | 50,8 | 67,3 | 28,0 | 4000 | 112,0 | 16000 | 320 | 6,47 |

The combination of high temperature and high pressure could reduce the hose life.

Hose layline example

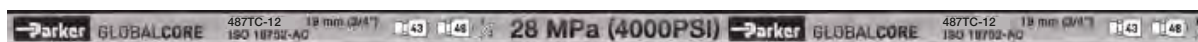

Caa-8

Catalogue 4400/UK

487ST

No-Skive GlobalCore Super Tough

Sizes -4 to -12 exceed ISO 18752-AC
Sizes -16 to -32 exceed ISO 18752-CC

Primary Applications

Medium pressure hydraulic applications
with extremely high abrasion risks

Applicable Specifications

Exceed ISO 18752-AC and ISO 18752-BC

Construction

Inner tube: Synthetic rubber
Reinforcement: One or two high-tensile steel wire braids
for sizes -4 up to -12
(four-spiral wires for sizes -16 up to -24
Six-spiral wires for size -32)
Cover: Synthetic rubber
with a special polyethylene coating

Temperature Range -40 °C up to +125 °C

Exception: Air max. +70 °C
Water max. +85 °C



- GlobalCore - *No-Skive*
- ½ ISO 18752 minimum bend radius
- Low force to flex for ease of installation
- 28 MPa constant working pressure
- Extreme abrasion resistant
SUPER TOUGH cover

Recommended Fluids

Hydraulic fluids on a mineral-oil basis, water-glycol and lubricating oils, air and water. For air and gas applications with a pressure exceeding 1.7 MPa, the cover must be pin-pricked. Consult the chemical compatibility section on pages **Ab-26** to **Ab-34** for more detailed information.

Fitting Series

Series 43/48 for sizes -4 up to -12 **43** **48**
Series 43 for size -16 **43**
Series 77 for sizes -20 up to -32 **77**

| Part Number | Hose I.D. | | | | Hose O.D. mm | Pressure Rating | | | | min. bend radius mm | weight kg |
|-------------|-----------|-------|------|------|-----------------|------------------------------|------|----------------------------|-------|------------------------|--------------|
| | DN | Inch | Size | mm | | max. working pressure MPa | psi | min. burst pressure MPa | psi | | |
| 487ST-4 | 6 | 1/4 | -4 | 6.4 | 13.1 | 28.0 | 4000 | 112.0 | 16000 | 50 | 0.30 |
| 487ST-6 | 10 | 3/8 | -6 | 9.5 | 17.2 | 28.0 | 4000 | 112.0 | 16000 | 65 | 0.42 |
| 487ST-8 | 12 | 1/2 | -8 | 12.7 | 20.4 | 28.0 | 4000 | 112.0 | 16000 | 90 | 0.52 |
| 487ST-10 | 16 | 5/8 | -10 | 15.9 | 23.9 | 28.0 | 4000 | 112.0 | 16000 | 100 | 0.66 |
| 487ST-12 | 19 | 3/4 | -12 | 19.1 | 27.8 | 28.0 | 4000 | 112.0 | 16000 | 120 | 0.86 |
| 487ST-16 | 25 | 1 | -16 | 25.4 | 37.8 | 28.0 | 4000 | 112.0 | 16000 | 150 | 1.99 |
| 487ST-20 | 31 | 1 1/4 | -20 | 31.8 | 46.3 | 28.0 | 4000 | 112.0 | 16000 | 210 | 2.59 |
| 487ST-24 | 38 | 1 1/2 | -24 | 38.1 | 52.8 | 28.0 | 4000 | 112.0 | 16000 | 250 | 3.08 |
| 487ST-32 | 51 | 2 | -32 | 50.8 | 67.3 | 28.0 | 4000 | 112.0 | 16000 | 320 | 6.47 |

The combination of high temperature and high pressure could reduce the hose life.

Hose layline example

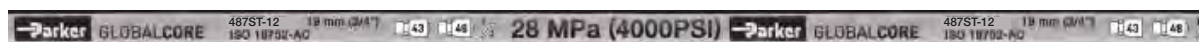

Medium Pressure

| Hoses | | | Page |
|--------|------------------------------------|-----------------------------|--------|
| Good | BCH1 <i>No-Skive</i> | Standard | Cab-1 |
| Good | BCH2 <i>No-Skive</i> | Standard | Cab-2 |
| | HT2 <i>No-Skive</i> | Low / High temperature | Cab-3 |
| | 301SN <i>No-Skive</i> | Standard | Cab-4 |
| | 304 <i>No-Skive</i> | Phosphate Ester | Cab-5 |
| Better | 412 <i>Elite No-Skive</i> | Pilot | Cab-6 |
| Better | 412ST <i>Elite No-Skive</i> | Pilot | Cab-7 |
| | 421RH <i>No-Skive</i> | Railway | Cab-8 |
| | 421SN <i>No-Skive</i> | Standard | Cab-9 |
| | 421TC <i>No-Skive</i> | Standard | Cab-10 |
| | 421WC <i>No-Skive</i> | Wire cover | Cab-11 |
| | 426 <i>No-Skive</i> | Low / High temperature | Cab-12 |
| | 436 <i>No-Skive</i> | Low / High temperature | Cab-13 |
| Better | 441 <i>Elite No-Skive</i> | Standard | Cab-14 |
| | 441RH <i>No-Skive</i> | Railway | Cab-15 |
| Better | 461LT <i>Elite No-Skive</i> | Low / High temperature | Cab-16 |
| Better | 462 <i>Elite No-Skive</i> | Standard | Cab-17 |
| | 462PU <i>No-Skive</i> | Polyurethane Cover | Cab-18 |
| | 462PU Twin <i>No-Skive</i> | Polyurethane Cover | Cab-19 |
| Better | 462TC <i>Elite No-Skive</i> | High abrasion resistance | Cab-20 |
| Better | 462ST <i>Elite No-Skive</i> | Extreme abrasion resistance | Cab-21 |
| | 463 <i>No-Skive</i> | Water cleaning | Cab-22 |
| | 471TC <i>No-Skive</i> | High abrasion resistance | Cab-23 |
| Better | 477 <i>Elite No-Skive</i> | Powerlift | Cab-24 |
| | 477RH <i>No-Skive</i> | Railway | Cab-25 |
| Better | 477TC <i>Elite No-Skive</i> | Powerlift | Cab-26 |
| Better | 477ST <i>Elite No-Skive</i> | Powerlift | Cab-27 |
| Better | 492 <i>Elite No-Skive</i> | Standard | Cab-28 |
| Better | 492TC <i>Elite No-Skive</i> | High abrasion resistance | Cab-29 |
| Better | 492ST <i>Elite No-Skive</i> | Extreme abrasion resistance | Cab-30 |
| | 493 <i>No-Skive</i> | Water cleaning | Cab-31 |
| | 692 <i>No-Skive</i> | Extremely flexible | Cab-32 |
| | 692Twin <i>No-Skive</i> | Extremely flexible | Cab-33 |
| | 692PU <i>No-Skive</i> | Polyurethane Cover | Cab-34 |
| | 692PU Twin <i>No-Skive</i> | Polyurethane Cover | Cab-35 |
| | 692TC <i>No-Skive</i> | Extremely flexible | Cab-36 |
| | 811 <i>No-Skive</i> | Suction | Cab-37 |
| | 811S <i>No-Skive</i> | Suction | Cab-38 |
| | 881 <i>No-Skive</i> | Suction | Cab-39 |

| Fittings Series | 43 | 46/48 | 2piece 48 | 2piece IF |
|-------------------------------|---------|---------|-----------|-----------|
| Chapter | Cb | Cc | Cd | Ce |
| DIN – Metric | 1 – 4 | 1 – 9 | | |
| BSP | 5 – 8 | 10 – 18 | | |
| SAE | 9 – 10 | 19 – 24 | 1 | |
| Flange | 11 – 13 | 25 – 29 | 2 | 1 – 3 |
| ORFS | 14 – 15 | 30 – 35 | | |
| JIS | | 36 – 37 | | |
| High Pressure Cleaning | | 38 – 39 | | |
| Others | | 40 | | |
| UPTC | | 41 – 42 | | |

Parker Hannifin assumes no liability for typographical errors or other errors



Standard

| | | | |
|----------------------------------------------------------------------------------------------------------------------------------------------------------------------------------------------------------------------------------------------------------|--------------------------------------------------------------------------------------------------------------------------------------------------------------------------------------------------------------------------------------------------------------------------|-------------------------------------------------------------------------------------------------------------------------------------------------------------------------------------------------------------------------------------------------------------------|-----------------------------------------------------------------------------------------------------------------------------------------------------------------|
| BCH1 Good Cab-1  <i>No-Skive</i> EN 857 1SC – ISO 11237 | BCH2 Good Cab-2  <i>No-Skive</i> EN 857 2SC – ISO 11237 | 301SN Cab-4  <i>No-Skive</i> EN 853 2SN – ISO 1436 Type 2 | 421SN Cab-9  <i>No-Skive</i> EN 853 1SN – ISO 1436 Type 1 |
| 441 Better Cab-14  <i>Elite No-Skive</i> ISO 11237 Type R16 – SAE 100R16 | 462 Better Cab-17  <i>Elite No-Skive Compact</i> Exceeds EN 857-2SC – ISO 11237 Type 2SC | 492 Better Cab-28  <i>Elite No-Skive Compact</i> EN 857 1SC – ISO 11237 Type 1SC | |

High abrasion resistance

| | | | |
|----------------------------------------------------------------------------------------------------------------------------------------------------------------|----------------------------------------------------------------------------------------------------------------------------------------------------------------------------------------------------------------------------------------------------------------------------------------|--------------------------------------------------------------------------------------------------------------------------------------------------------------------|----------------------------------------------------------------------------------------------------------------------------------------------------------------------------------------------------------------------------------------------------------------------------------|
| 421TC Cab-10  <i>No-Skive</i> EN 853 1SN – ISO 1436 Type 1 | 462TC Better Cab-20  <i>Elite No-Skive Compact Tough Cover</i> Exceeds EN 857-2SC – ISO 11237 Type 2SC | 471TC Cab-23  <i>No-Skive</i> EN 857 2SC – ISO 11237 Type 2SC | 492TC Better Cab-29  <i>Elite No-Skive Compact Tough Cover</i> EN 857 1SC – ISO 11237 Type 1SC |
|----------------------------------------------------------------------------------------------------------------------------------------------------------------|----------------------------------------------------------------------------------------------------------------------------------------------------------------------------------------------------------------------------------------------------------------------------------------|--------------------------------------------------------------------------------------------------------------------------------------------------------------------|----------------------------------------------------------------------------------------------------------------------------------------------------------------------------------------------------------------------------------------------------------------------------------|

Extreme abrasion resistance

| | |
|----------------------------------------------------------------------------------------------------------------------------------------------------------------------------------------------------------------------------------------------------------------------------------|----------------------------------------------------------------------------------------------------------------------------------------------------------------------------------------------------------------------------------------------------------------------------------|
| 462ST Better Cab-21  <i>Elite No-Skive Super Tough Compact</i> EN 857 2SC – ISO 11237 Type 2SC | 492ST Better Cab-30  <i>Elite No-Skive Super Tough Compact</i> EN 857 1SC – ISO 11237 Type 1SC |
|----------------------------------------------------------------------------------------------------------------------------------------------------------------------------------------------------------------------------------------------------------------------------------|----------------------------------------------------------------------------------------------------------------------------------------------------------------------------------------------------------------------------------------------------------------------------------|

Low / High temperature

| | | | |
|---------------------------------------------------------------------------------------------------------------------------------------------------------------|----------------------------------------------------------------------------------------------------------------------------------------------------------------|------------------------------------------------------------------------------------------------------------------------------------------------------------------------|-------------------------------------------------------------------------------------------------------------------------------------------------------------------------------------------------------------------------------------------------------------------|
| HT2 Cab-3  <i>No-Skive Compact</i> Parker specification | 426 Cab-12  <i>No-Skive</i> SAE 100R1AT high temperature | 436 Cab-13  <i>No-Skive Compact</i> SAE 100R16 high temperature | 461LT Better Cab-16  <i>Elite No-Skive Compact</i> EN 857 2SC low temperature |
|---------------------------------------------------------------------------------------------------------------------------------------------------------------|----------------------------------------------------------------------------------------------------------------------------------------------------------------|------------------------------------------------------------------------------------------------------------------------------------------------------------------------|-------------------------------------------------------------------------------------------------------------------------------------------------------------------------------------------------------------------------------------------------------------------|

Phosphate Ester

| |
|-----------------------------------------------------------------------------------------------------------------------------------------------------------------|
| 304 Cab-5  <i>No-Skive</i> Phosphate ester resistant hose |
|-----------------------------------------------------------------------------------------------------------------------------------------------------------------|

Railway

| | | |
|-----------------------------------------------------------------------------------------------------------------------------------------------------------------|--------------------------------------------------------------------------------------------------------------------------------------------------------------------------|-------------------------------------------------------------------------------------------------------------------------------------------------------------------------------------------------------|
| <p>421RH Cab-8</p>  <p><i>No-Skive</i> Fire-retardant cover</p> | <p>441RH Cab-15</p>  <p><i>No-Skive Compact</i> Fire-retardant cover</p> | <p>477RH Cab-25</p>  <p><i>Elite No-Skive PowerLift</i> 2 wire braided with fire-retardant cover</p> |
|-----------------------------------------------------------------------------------------------------------------------------------------------------------------|--------------------------------------------------------------------------------------------------------------------------------------------------------------------------|-------------------------------------------------------------------------------------------------------------------------------------------------------------------------------------------------------|

Water cleaning

| | |
|---------------------------------------------------------------------------------------------------------------------------------------------------------------------------------------------|---------------------------------------------------------------------------------------------------------------------------------------------------------------------------------------------|
| <p>463 Cab-22</p>  <p><i>No-Skive Compact</i> High pressure water cleaning applications</p> | <p>493 Cab-31</p>  <p><i>No-Skive Compact</i> High pressure water cleaning applications</p> |
|---------------------------------------------------------------------------------------------------------------------------------------------------------------------------------------------|---------------------------------------------------------------------------------------------------------------------------------------------------------------------------------------------|

Pilot

| | |
|-----------------------------------------------------------------------------------------------------------------------------------------------------------------------------------------------------------|-------------------------------------------------------------------------------------------------------------------------------------------------------------------------------------------------------------|
| <p>412 Better Cab-6</p>  <p><i>Elite No-Skive RemoFlex</i> 1 wire braided hose for pilot lines</p> | <p>412ST Better Cab-7</p>  <p><i>Elite No-Skive RemoFlex</i> 1 wire braided hose for pilot lines</p> |
|-----------------------------------------------------------------------------------------------------------------------------------------------------------------------------------------------------------|-------------------------------------------------------------------------------------------------------------------------------------------------------------------------------------------------------------|

Wire cover

421WC
Cab-11



No-Skive
Galvanised steel wire cover

Powerlift

| | | |
|------------------------------------------------------------------------------------------------------------------------------------------------------------------------------------------|--------------------------------------------------------------------------------------------------------------------------------------------------------------------------------------------------------|---------------------------------------------------------------------------------------------------------------------------------------------------------------------------------------------|
| <p>477 Better Cab-24</p>  <p><i>Elite No-Skive PowerLift</i> 2 wire braided</p> | <p>477TC Better Cab-26</p>  <p><i>Elite No-Skive PowerLift Tough Cover</i> 2 wire braided</p> | <p>477ST Better Cab-27</p>  <p><i>Elite No-Skive PowerLift</i> 2 wire braided</p> |
|------------------------------------------------------------------------------------------------------------------------------------------------------------------------------------------|--------------------------------------------------------------------------------------------------------------------------------------------------------------------------------------------------------|---------------------------------------------------------------------------------------------------------------------------------------------------------------------------------------------|

Extremely flexible

| | | |
|------------------------------------------------------------------------------------------------------------------------------------------------------------------------------------------|---------------------------------------------------------------------------------------------------------------------------------------------------------------------------------------------------|---------------------------------------------------------------------------------------------------------------------------------------------------------------------------------------------------------|
| <p>692 Cab-32</p>  <p><i>No-Skive Compact</i> Constant pressure, tight bend radius</p> | <p>692Twin Cab-33</p>  <p><i>No-Skive Compact</i> Twin constant pressure, tight bend radius</p> | <p>692TC Cab-36</p>  <p><i>No-Skive Compact Tough Cover</i> Constant pressure, tight bend radius</p> |
|------------------------------------------------------------------------------------------------------------------------------------------------------------------------------------------|---------------------------------------------------------------------------------------------------------------------------------------------------------------------------------------------------|---------------------------------------------------------------------------------------------------------------------------------------------------------------------------------------------------------|

Hose

Polyurethane Cover



Suction



BCH1

No-Skive

EN 857 1SC – ISO 11237



- *No-Skive* hose construction
- High performance
- NBR inner tube – extended fluid compatibility
- Meets specified working pressure and bend radius of EN 857 1SC
- Synthetic rubber cover compound
- Tight bending radius

Primary Applications

Demanding medium pressure hydraulic applications in all markets

Construction

Inner tube: Nitrile (NBR)
Reinforcement: One high-tensile steel wire braid
Cover: Synthetic rubber

Temperature Range -40 °C up to +100 °C

Exception: Air max. +70 °C
Water max. +85 °C

Recommended Fluids

Hydraulic fluids on a mineral-oil basis, water-glycol and lubricating oils, air and water. For air and gas applications with a pressure exceeding 1.7 MPa, the cover must be pin-pricked.

Consult the chemical compatibility section on pages **Ab-26** to **Ab-34** for more detailed information.

Fitting Series



Hose

| Part Number | Hose I.D. | | | | Hose O.D. mm | Pressure Rating | | | | min. bend radius mm | weight kg |
|-------------|-----------|------|------|------|-----------------|------------------------------|------|----------------------------|-------|------------------------|--------------|
| | DN | Inch | Size | mm | | max. working pressure MPa | psi | min. burst pressure MPa | psi | | |
| BCH1-4 | 6 | 1/4 | -4 | 6.4 | 11.5 | 22.5 | 3260 | 90.0 | 13050 | 75 | 0.17 |
| BCH1-5 | 8 | 5/16 | -5 | 7.9 | 13.6 | 21.5 | 3110 | 86.0 | 12470 | 85 | 0.20 |
| BCH1-6 | 10 | 3/8 | -6 | 9.5 | 15.5 | 18.0 | 2610 | 72.0 | 10440 | 90 | 0.24 |
| BCH1-8 | 12 | 1/2 | -8 | 12.7 | 18.9 | 16.0 | 2320 | 64.0 | 9280 | 130 | 0.33 |
| BCH1-10 | 16 | 5/8 | -10 | 15.9 | 22.2 | 13.0 | 1885 | 52.0 | 7540 | 150 | 0.41 |
| BCH1-12 | 20 | 3/4 | -12 | 19.1 | 26.0 | 10.5 | 1520 | 42.0 | 6080 | 180 | 0.56 |
| BCH1-16 | 25 | 1 | -16 | 25.4 | 33.3 | 8.8 | 1275 | 35.2 | 5100 | 230 | 0.75 |

The combination of high temperature and high pressure could reduce the hose life.

Hose layline example



BCH2

No-Skive

EN 857 2SC – ISO 11237



- *No-Skive* hose construction
- High performance
- NBR inner tube – extended fluid compatibility
- Meets specified working pressure and bend radius of EN 857 2SC
- Synthetic rubber cover compound
- Tight bending radius

Primary Applications

Demanding medium pressure hydraulic applications in all markets

Construction

Inner tube: Nitrile (NBR)
Reinforcement: Two high-tensile steel wire braids
Cover: Synthetic rubber

Temperature Range -40 °C up to +100 °C

Exception: Air max. +70 °C
Water max. +85 °C

Recommended Fluids

Hydraulic fluids on a mineral-oil basis, water-glycol and lubricating oils, air and water. For air and gas applications with a pressure exceeding 1.7 MPa, the cover must be pin-pricked.

Consult the chemical compatibility section on pages **Ab-26** to **Ab-34** for more detailed information.

Fitting Series



| Part Number | Hose I.D. | | | | Hose O.D. mm | Pressure Rating | | | | min. bend radius mm | weight kg |
|-------------|-----------|------|------|------|-----------------|------------------------------|------|----------------------------|-------|------------------------|--------------|
| | DN | Inch | Size | mm | | max. working pressure MPa | psi | min. burst pressure MPa | psi | | |
| BCH2-4 | 6 | 1/4 | -4 | 6.4 | 13.4 | 40.0 | 5800 | 160.0 | 23200 | 75 | 0.28 |
| BCH2-5 | 8 | 5/16 | -5 | 7.9 | 15.0 | 35.0 | 5000 | 140.0 | 20000 | 85 | 0.31 |
| BCH2-6 | 10 | 3/8 | -6 | 9.5 | 17.2 | 33.0 | 4800 | 132.0 | 19200 | 90 | 0.39 |
| BCH2-8 | 12 | 1/2 | -8 | 12.7 | 20.4 | 27.5 | 4000 | 110.0 | 16000 | 130 | 0.50 |
| BCH2-10 | 16 | 5/8 | -10 | 15.9 | 23.9 | 25.0 | 3600 | 100.0 | 14400 | 170 | 0.63 |
| BCH2-12 | 20 | 3/4 | -12 | 19.1 | 27.7 | 21.5 | 3100 | 86.0 | 12400 | 200 | 0.81 |
| BCH2-16 | 25 | 1 | -16 | 25.4 | 35.4 | 16.5 | 2400 | 66.0 | 9600 | 250 | 1.06 |

The combination of high temperature and high pressure could reduce the hose life.

Hose layline example



Medium Pressure
Low / High temperature

Parkrimp No-Skive Hose
HT2

HT2

No-Skive Compact
Parker specification



- *No-Skive* hose construction – Compact design
- +125 °C working temperature with peaks up to +135 °C

Primary Applications

Many industrial and mobile applications, with typical usage seen on agricultural machines or in power steering circuits

Applicable Specifications

Parker Specification

Construction

Inner tube: Nitrile (NBR)
Reinforcement: Two high-tensile steel wire braids
Cover: Synthetic rubber

Temperature Range -40 °C up to +125 °C
with peaks up to +135 °C

Exception: Air max. +70 °C
Water max. +85 °C

Recommended Fluids

Hydraulic fluids on a mineral-oil basis, water-glycol and lubricating oils, air and water. For air and gas applications with a pressure exceeding 1.7 MPa, the cover must be pin-pricked. Consult the chemical compatibility section on pages **Ab-26** to **Ab-34** for more detailed information.

Fitting Series



Hose

| Part Number | Hose I.D. | | | | Hose O.D. mm | Pressure Rating | | | | min. bend radius mm | weight kg |
|-------------|-----------|------|------|------|-----------------|------------------------------|------|----------------------------|-------|------------------------|--------------|
| | DN | Inch | Size | mm | | max. working pressure MPa | psi | min. burst pressure MPa | psi | | |
| HT2-4 | 6 | 1/4 | 4 | 6.4 | 13.4 | 35.0 | 5000 | 140.0 | 20000 | 50 | 0.30 |
| HT2-5 | 8 | 5/16 | 5 | 7.9 | 15.0 | 29.7 | 4250 | 118.8 | 17000 | 55 | 0.35 |
| HT2-6 | 10 | 3/8 | 6 | 9.5 | 17.2 | 28.0 | 4000 | 112.0 | 16000 | 65 | 0.42 |
| HT2-8 | 12 | 1/2 | 8 | 12.7 | 20.4 | 24.5 | 3500 | 98.0 | 14000 | 90 | 0.52 |
| HT2-10 | 16 | 5/8 | 10 | 15.9 | 23.9 | 19.2 | 2750 | 76.8 | 11000 | 100 | 0.66 |
| HT2-12 | 19 | 3/4 | 12 | 19.1 | 27.7 | 15.7 | 2250 | 62.8 | 9000 | 120 | 0.86 |
| HT2-16 | 25 | 1 | 16 | 25.4 | 35.4 | 14.0 | 2000 | 56.0 | 8000 | 150 | 1.17 |

The combination of high temperature and high pressure could reduce the hose life.

Hose layline example



Cab-3

Catalogue 4400/UK

301SN

No-Skive

EN 853 2SN – ISO 1436 Type 2



- *No-Skive* thin cover hose construction
- Nitrile (NBR) inner tube
– extended fluid compatibility

Primary Applications

General medium pressure hydraulic applications

Type Approvals

Details please find on pages **Ab-16** to **Ab-19**

Applicable Specifications

EN 853 2SN – ISO 1436 Type 2 – SAE 100R2AT

Construction

Inner tube: Nitrile (NBR)
Reinforcement: Two high-tensile steel wire braids
Cover: Synthetic rubber

Temperature Range -40 °C up to +100 °C

Exception: Air max. +70 °C
Water max. +85 °C

Recommended Fluids

Hydraulic fluids on a mineral-oil basis, water-glycol and lubricating oils, air and water. For air and gas applications with a pressure exceeding 1.7 MPa, the cover must be pin-pricked.

Consult the chemical compatibility section on pages **Ab-26** to **Ab-34** for more detailed information.

Fitting Series



| Part Number | Hose I.D. | | | | Hose O.D. mm | Pressure Rating | | | | min. bend radius mm | weight kg |
|-------------|-----------|-------|------|------|-----------------|------------------------------|------|----------------------------|-------|------------------------|--------------|
| | DN | Inch | Size | mm | | max. working pressure MPa | psi | min. burst pressure MPa | psi | | |
| 301SN-4 | 6 | 1/4 | -4 | 6.4 | 15.0 | 40.0 | 5800 | 160.0 | 23200 | 100 | 0.39 |
| 301SN-5 | 8 | 5/16 | -5 | 7.9 | 16.6 | 35.0 | 5075 | 140.0 | 20300 | 115 | 0.42 |
| 301SN-6 | 10 | 3/8 | -6 | 9.5 | 19.0 | 33.0 | 4775 | 132.0 | 19100 | 130 | 0.55 |
| 301SN-8 | 12 | 1/2 | -8 | 12.7 | 22.2 | 27.5 | 4000 | 110.0 | 16000 | 180 | 0.67 |
| 301SN-10 | 16 | 5/8 | -10 | 15.9 | 25.4 | 25.0 | 3600 | 100.0 | 14500 | 200 | 0.77 |
| 301SN-12 | 19 | 3/4 | -12 | 19.1 | 29.3 | 21.5 | 3100 | 86.0 | 12400 | 240 | 1.00 |
| 301SN-16 | 25 | 1 | -16 | 25.4 | 38.1 | 16.5 | 2400 | 66.0 | 9600 | 300 | 1.49 |
| 301SN-20 | 31 | 1 1/4 | -20 | 31.8 | 47.5 | 12.5 | 1800 | 50.0 | 7200 | 420 | 1.73 |
| 301SN-24 | 38 | 1 1/2 | -24 | 38.1 | 55.0 | 9.0 | 1300 | 36.0 | 5200 | 500 | 2.14 |
| 301SN-32 | 51 | 2 | -32 | 50.8 | 67.0 | 8.0 | 1150 | 32.0 | 4600 | 630 | 2.96 |

The combination of high temperature and high pressure could reduce the hose life.

Hose layline example

PARKER NO-SKIVE 301SN-4 WP 40,0 MPa [400 BAR] | · SAE100R2AT-4 6,3MM [1/4"] X 2W EN853/2SN/6/DIN



304

No-Skive

Phosphate ester resistant hose

Primary Applications

Aerospace, foundries, steel mills:
Medium pressure hydraulic applications with phosphate ester fluids

Applicable Specifications

Parker Specification

Restrictions

Do not allow tube to contact any petroleum base fluids.
Use liquid soap as hose lubricant.

Construction

Inner tube: EPDM synthetic rubber
Reinforcement: Two high-tensile steel wire braids
Cover: EPDM synthetic rubber green, phosphate ester and weather resistant

Temperature Range -40 °C up to +80 °C

Exception: Air max. +70 °C
Water, water glycol fluids .. max. +85 °C



- *No-Skive* thin cover hose construction
- Phosphate ester and weather resistant, green, EPDM synthetic rubber cover
- SAE 100R2 pressure rating

Recommended Fluids

Phosphate ester based hydraulic fluids, water-glycol based fluids, air and water.
Consult the chemical compatibility section on pages **Ab-26** to **Ab-34** for more detailed information.

Fitting Series

Series 43 for sizes -4 up to -32
Series 48 for sizes -20 up to -32



| Part Number | Hose I.D. | | | | Hose O.D. mm | Pressure Rating | | | | min. bend radius mm | weight kg |
|-------------|-----------|-------|------|------|-----------------|------------------------------|------|----------------------------|-------|------------------------|--------------|
| | DN | Inch | Size | mm | | max. working pressure MPa | psi | min. burst pressure MPa | psi | | |
| 304-4 | 6 | 1/4 | -4 | 6.4 | 15.0 | 34.5 | 5000 | 138.0 | 20000 | 100 | 0.39 |
| 304-6 | 10 | 3/8 | -6 | 9.5 | 19.0 | 27.5 | 4000 | 110.0 | 16000 | 130 | 0.55 |
| 304-8 | 12 | 1/2 | -8 | 12.7 | 22.0 | 24.0 | 3500 | 96.0 | 14000 | 180 | 0.67 |
| 304-12 | 19 | 3/4 | -12 | 19.1 | 30.0 | 15.5 | 2250 | 62.0 | 9000 | 240 | 1.00 |
| 304-16 | 25 | 1 | -16 | 25.4 | 38.0 | 13.8 | 2000 | 55.0 | 8000 | 300 | 1.49 |
| 304-20 | 31 | 1 1/4 | -20 | 31.8 | 48.0 | 11.2 | 1625 | 45.0 | 6500 | 420 | 1.73 |
| 304-24 | 38 | 1 1/2 | -24 | 38.1 | 55.0 | 8.6 | 1250 | 35.0 | 5075 | 500 | 2.14 |
| 304-32 | 51 | 2 | -32 | 50.8 | 68.0 | 7.8 | 1125 | 31.0 | 4500 | 630 | 2.96 |

The combination of high temperature and high pressure could reduce the hose life.

Hose layline example

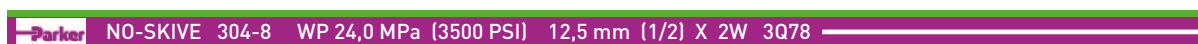

412

Elite No-Skive RemoFlex

1 wire braided hose for pilot lines

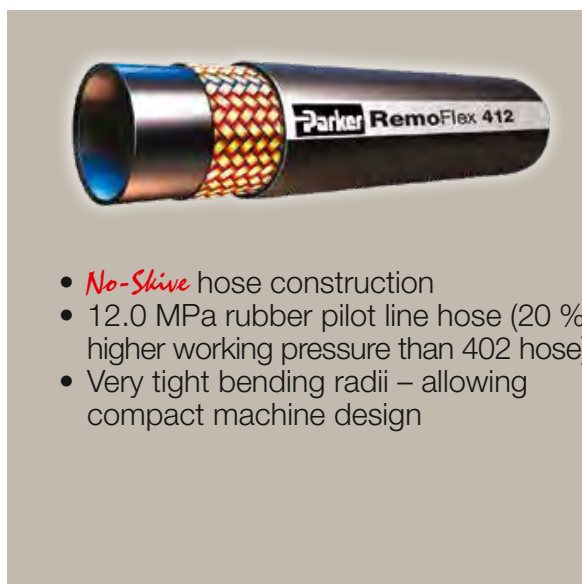

- *No-Skive* hose construction
- 12.0 MPa rubber pilot line hose (20 % higher working pressure than 402 hose)
- Very tight bending radii – allowing compact machine design

Primary Applications

Mobile hydraulic equipment: Pilot lines

Construction

Inner tube: Nitrile (NBR)
Reinforcement: One high-tensile steel wire braid
Cover: Synthetic rubber

Temperature Range -40 °C up to +100 °C

Exception: Air max. +70 °C
Water max. +85 °C

Recommended Fluids

Hydraulic fluids on a mineral-oil basis, water-glycol and lubricating oils, air and water. For air and gas applications with a pressure exceeding 1.7 MPa, the cover must be pin-pricked.

Consult the chemical compatibility section on pages **Ab-26** to **Ab-34** for more detailed information.

Fitting Series

- Available as complete hose assembly
- Compatible with 2-piece fittings for use with adjustable crimpers only (47 series nipple and 10049 series shell)

| Part Number | Hose I.D. | | | | Hose O.D. mm | Pressure Rating | | | | min. bend radius mm | weight kg |
|-------------|-----------|------|------|-----|-----------------|------------------------------|------|----------------------------|------|------------------------|--------------|
| | DN | Inch | Size | mm | | max. working pressure MPa | psi | min. burst pressure MPa | psi | | |
| 412-3 | 5 | 3/16 | -3 | 4.8 | 9.1 | 12.0 | 1700 | 48.0 | 6800 | 20 | 0.08 |
| 412-4 | 6 | 1/4 | -4 | 6.4 | 11.0 | 12.0 | 1700 | 48.0 | 6800 | 25 | 0.14 |
| 412-5 | 8 | 5/16 | -5 | 7.9 | 13.0 | 12.0 | 1700 | 48.0 | 6800 | 30 | 0.18 |
| 412-6 | 10 | 3/8 | -6 | 9.5 | 14.0 | 12.0 | 1700 | 48.0 | 6800 | 40 | 0.23 |

The combination of high temperature and high pressure could reduce the hose life.

Hose layline example

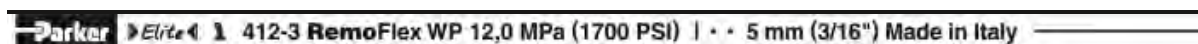

412ST

Elite No-Skive RemoFlex

1 wire braided hose for pilot lines



- *No-Skive* hose construction
- 12.0 MPa rubber pilot line hose
- Very tight bending radii – allowing compact machine design
- Extreme abrasion resistant **SUPER TOUGH** cover

Primary Applications

Mobile hydraulic equipment: Pilot lines

Construction

Inner tube: Nitrile (NBR)
Reinforcement: One high-tensile steel wire braid
Cover: Synthetic rubber with a special polyethylene coating

Temperature Range -40 °C up to +100 °C

Exception: Air max. +70 °C
Water max. +85 °C

Recommended Fluids

Hydraulic fluids on a mineral-oil basis, water-glycol and lubricating oils, air and water. For air and gas applications with a pressure exceeding 1.7 MPa, the cover must be pin-pricked.

Consult the chemical compatibility section on pages **Ab-26** to **Ab-34** for more detailed information.

Fitting Series

- Available as complete hose assembly
- Compatible with 2-piece fittings for use with adjustable crimpers only (47 series nipple and 10049 series shell)

| Part Number | Hose I.D. | | | | Hose O.D. mm | Pressure Rating | | | | min. bend radius mm | weight kg |
|-------------|-----------|------|------|-----|-----------------|------------------------------|------|----------------------------|------|------------------------|--------------|
| | DN | Inch | Size | mm | | max. working pressure MPa | psi | min. burst pressure MPa | psi | | |
| 412ST-3 | 5 | 3/16 | -3 | 4.8 | 9.6 | 12.0 | 1700 | 48.0 | 6800 | 20 | 0.08 |
| 412ST-4 | 6 | 1/4 | -4 | 6.4 | 11.6 | 12.0 | 1700 | 48.0 | 6800 | 25 | 0.14 |
| 412ST-5 | 8 | 5/16 | -5 | 7.9 | 13.0 | 12.0 | 1700 | 48.0 | 6800 | 30 | 0.18 |
| 412ST-6 | 10 | 3/8 | -6 | 9.5 | 14.0 | 12.0 | 1700 | 48.0 | 6800 | 40 | 0.23 |

The combination of high temperature and high pressure could reduce the hose life.

Hose layline example

Parker Elite **SUPER TOUGH** 412ST-6 RemoFlex WP 12,0 MPa (1700 PSI) | • • 9,5 mm (3/8") Made in Italy



421RH

No-Skive

Fire-retardant cover

Primary Applications

General medium-pressure hydraulic and pneumatic systems as well as water and oil cooling circuits

Type Approvals

Details please find on pages **Ab-16** to **Ab-19**

Applicable Specifications

EN 853 1SN – ISO 1436 Typ 1 – SAE 100R1AT

Construction

Inner tube: Nitrile (NBR)
Reinforcement: One high-tensile steel wire braid
Cover: Fire retardant synthetic rubber

Temperature Range -40 °C up to +100 °C

Exception: Air max. +70 °C
Water max. +85 °C



- *No-Skive* thin cover hose construction
- Nitrile (NBR) inner tube
– extended fluid compatibility
- Suitable with 48 series fittings
- Fire-retardant cover
- Railway approved:
 - European Standard EN45545 HL2 for R22 (internal) and R23 (external)
 - ISO 15540

Recommended Fluids

Hydraulic fluids on a mineral-oil basis, water-glycol and lubricating oils, air and water. For air and gas applications with a pressure exceeding 1.7 MPa, the cover must be pin-pricked. Consult the chemical compatibility section on pages **Ab-26** to **Ab-34** for more detailed information.

Fitting Series



| Part Number | Hose I.D. | | | | Hose O.D. mm | Pressure Rating | | | | min. bend radius mm | weight kg |
|-------------|-----------|-------|------|------|-----------------|------------------------------|-----|----------------------------|------|------------------------|--------------|
| | DN | Inch | Size | mm | | max. working pressure MPa | psi | min. burst pressure MPa | psi | | |
| 421RH-20 | 31 | 1 1/4 | -20 | 31.8 | 44.8 | 6.3 | 900 | 25.0 | 3600 | 420 | 1.19 |
| 421RH-24 | 38 | 1 1/2 | -24 | 38.1 | 51.1 | 5.0 | 725 | 20.0 | 2900 | 500 | 1.49 |
| 421RH-32 | 51 | 2 | -32 | 50.8 | 64.7 | 4.0 | 575 | 16.0 | 2300 | 630 | 2.23 |

The combination of high temperature and high pressure could reduce the hose life.

Hose layline example

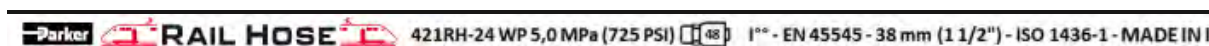

Cab-8

Catalogue 4400/UK

421SN

No-Skive

EN 853 1SN – ISO 1436 Type 1



- *No-Skive* thin cover hose construction
- Nitrile (NBR) inner tube
– extended fluid compatibility

Primary Applications

General medium pressure hydraulic applications

Type Approvals

Details please find on pages **Ab-16** to **Ab-19**

Applicable Specifications

EN 853 1SN – ISO 1436 Type 1 – SAE 100R1AT

Construction

Inner tube: Nitrile (NBR)
Reinforcement: One high-tensile steel wire braid
Cover: Synthetic rubber

Temperature Range -40 °C up to +100 °C

Exception: Air max. +70 °C
Water max. +85 °C

Recommended Fluids

Hydraulic fluids on a mineral-oil basis, water-glycol and lubricating oils, air and water. For air and gas applications with a pressure exceeding 1.7 MPa, the cover must be pin-pricked.

Consult the chemical compatibility section on pages **Ab-26** to **Ab-34** for more detailed information.

Fitting Series



Hose

| Part Number | Hose I.D. | | | | Hose O.D. mm | Pressure Rating | | | | min. bend radius mm | weight kg |
|-------------|-----------|-------|------|------|-----------------|------------------------------|------|----------------------------|-------|------------------------|--------------|
| | DN | Inch | Size | mm | | max. working pressure MPa | psi | min. burst pressure MPa | psi | | |
| 421SN-4 | 6 | 1/4 | -4 | 6.4 | 13.4 | 22.5 | 3250 | 90.0 | 13000 | 100 | 0.24 |
| 421SN-5 | 8 | 5/16 | -5 | 7.9 | 15.0 | 21.5 | 3125 | 86.0 | 12500 | 115 | 0.27 |
| 421SN-6 | 10 | 3/8 | -6 | 9.5 | 17.4 | 18.0 | 2600 | 72.0 | 10400 | 130 | 0.34 |
| 421SN-8 | 12 | 1/2 | -8 | 12.7 | 20.7 | 16.0 | 2325 | 64.0 | 9300 | 180 | 0.43 |
| 421SN-10 | 16 | 5/8 | -10 | 15.9 | 23.9 | 13.0 | 1875 | 52.0 | 7500 | 200 | 0.49 |
| 421SN-12 | 19 | 3/4 | -12 | 19.1 | 27.8 | 10.5 | 1525 | 42.0 | 6100 | 240 | 0.63 |
| 421SN-16 | 25 | 1 | -16 | 25.4 | 35.8 | 8.8 | 1275 | 35.0 | 5075 | 300 | 0.94 |
| 421SN-20 | 31 | 1 1/4 | -20 | 31.8 | 44.8 | 6.3 | 900 | 25.2 | 3600 | 420 | 1.19 |
| 421SN-24 | 38 | 1 1/2 | -24 | 38.1 | 51.1 | 5.0 | 725 | 20.0 | 2900 | 500 | 1.49 |
| 421SN-32 | 51 | 2 | -32 | 50.8 | 64.7 | 4.0 | 575 | 16.0 | 2300 | 630 | 2.23 |

The combination of high temperature and high pressure could reduce the hose life.

Hose layline example

PARKER NO-SKIVE 421SN-8 WP 16,0 MPa (160 BAR) l * * SAE 100R1AT-8 12,5 MM (1/2) X1W EN 853/1SN/12/DIN



421TC

No-Skive

EN 853 1SN – ISO 1436 Type 1

Primary Applications

Demanding medium pressure hydraulic applications

Type Approvals

Details please find on pages **Ab-16** to **Ab-19**

Applicable Specifications

EN 853 1SN – ISO 1436 Type 1 – SAE 100R1AT

Construction

Inner Tube: Nitrile (NBR)

Reinforcement: One high-tensile steel wire braid

Cover: MSHA approved synthetic rubber

Temperature Range -40 °C up to +100 °C

Exception: Air max. +70 °C

Water max. +85 °C



- *No-Skive* thin cover hose construction
- Nitrile (NBR) inner tube
– extended fluid compatibility
- Highly abrasion resistant **TOUGH COVER**
- MSHA approved
- Hose is suitable for temporary immersion in mineral oil up to 70 °C with frequent inspections

Recommended Fluids

Hydraulic fluids on a mineral-oil basis, water-glycol and lubricating oils, air and water. For air and gas applications with a pressure exceeding 1.7 MPa, the cover must be pin-pricked.

Consult the chemical compatibility section on pages **Ab-26** to **Ab-34** for more detailed information.

Fitting Series



| Part Number | Hose I.D. | | | | Hose O.D. mm | Pressure Rating | | | | min. bend radius mm | weight kg |
|-------------|-----------|-------|------|------|-----------------|------------------------------|------|----------------------------|-------|------------------------|--------------|
| | DN | Inch | Size | mm | | max. working pressure MPa | psi | min. burst pressure MPa | psi | | |
| 421TC-4 | 6 | 1/4 | -4 | 6.4 | 13.4 | 22.5 | 3250 | 90.0 | 13000 | 100 | 0.24 |
| 421TC-5 | 8 | 5/16 | -5 | 7.9 | 15.0 | 21.5 | 3125 | 86.0 | 12500 | 115 | 0.27 |
| 421RTC-6 | 10 | 3/8 | -6 | 9.5 | 17.4 | 18.0 | 2600 | 72.0 | 10400 | 130 | 0.34 |
| 421TC-8 | 12 | 1/2 | -8 | 12.7 | 20.7 | 16.0 | 2325 | 64.0 | 9300 | 180 | 0.43 |
| 421TC-10 | 16 | 5/8 | -10 | 15.9 | 23.9 | 13.0 | 1875 | 52.0 | 7500 | 200 | 0.49 |
| 421TC-12 | 19 | 3/4 | -12 | 19.1 | 27.8 | 10.5 | 1525 | 42.0 | 6100 | 240 | 0.63 |
| 421TC-16 | 25 | 1 | -16 | 25.4 | 35.8 | 8.8 | 1275 | 35.0 | 5075 | 300 | 0.94 |
| 421TC-20 | 31 | 1 1/4 | -20 | 31.8 | 44.8 | 6.3 | 900 | 25.2 | 3600 | 420 | 1.19 |
| 421TC-24 | 38 | 1 1/2 | -24 | 38.1 | 51.1 | 5.0 | 725 | 20.0 | 2900 | 500 | 1.49 |
| 421TC-32 | 51 | 2 | -32 | 50.8 | 64.7 | 4.0 | 575 | 16.0 | 2300 | 630 | 2.23 |

The combination of high temperature and high pressure could reduce the hose life.

Hose layline example



Medium Pressure

Wire cover

Parkrimp No-Skive Hose

421WC

421WC

No-Skive

Galvanised steel wire cover



- *No-Skive* thin cover hose construction
- Metal and glass hot-spot resistance

Primary Applications

Machine tool and glass industry

Applicable Specifications

SAE 100 R1AT

Construction

Inner tube: Synthetic rubber
 Reinforcement: One high-tensile steel wire braid
 Cover: Galvanized steel wire

Recommended Fluids

Hydraulic fluids on a mineral-oil basis, water-glycol and lubricating oils, air and water.

Consult the chemical compatibility section on pages **Ab-26** to **Ab-34** for more detailed information.

Temperature Range -40 °C up to +125 °C

Exception: Air max. +70 °C

Water max. +85 °C

Fitting Series



| Part Number | Hose I.D. | | | | Hose O.D. mm | Pressure Rating | | | | min. bend radius mm | weight kg |
|-------------|-----------|------|------|------|-----------------|------------------------------|------|----------------------------|-------|------------------------|--------------|
| | DN | Inch | Size | mm | | max. working pressure MPa | psi | min. burst pressure MPa | psi | | |
| 421WC-4 | 6 | 1/4 | -4 | 6.4 | 15.0 | 19.0 | 2750 | 76.0 | 11000 | 100 | 0.38 |
| 421WC-6 | 10 | 3/8 | -6 | 9.5 | 19.0 | 15.5 | 2250 | 62.0 | 9000 | 130 | 0.54 |
| 421WC-8 | 12 | 1/2 | -8 | 12.7 | 22.0 | 13.8 | 2000 | 55.0 | 8000 | 180 | 0.67 |
| 421WC-12 | 19 | 3/4 | -12 | 19.1 | 29.0 | 8.6 | 1250 | 35.0 | 5075 | 240 | 0.95 |
| 421WC-16 | 25 | 1 | -16 | 25.4 | 37.0 | 6.9 | 1000 | 28.0 | 4000 | 300 | 1.31 |

The combination of high temperature and high pressure could reduce the hose life.

Hose

Medium Pressure
Low / High temperature

Parkrimp No-Skive Hose
426

426

No-Skive

SAE 100R1AT high temperature

Primary Applications

Medium pressure hydraulic applications at high temperature

Type Approvals

Details please find on pages **Ab-16** to **Ab-19**

Applicable Specifications

SAE 100 R1AT

Construction

Inner tube: PKR synthetic rubber
Reinforcement: One high-tensile steel wire braid
Cover: Synthetic rubber, blue

Temperature Range -46 °C up to +150 °C

Exception: Air max. +70 °C
Water, water glycol fluids .. max. +85 °C



- *No-Skive* thin cover hose construction
- SAE 100R1 pressure rating
- Ideal for high temperature applications

Recommended Fluids

Hydraulic fluids on a mineral-oil basis, water-glycol and lubricating oils, air and water.

Consult the chemical compatibility section on pages **Ab-26** to **Ab-34** for more detailed information.

Fitting Series

Series 43 for sizes -4 up to -6

Series 48 for sizes -8 up to -32



| Part Number | Hose I.D. | | | | Hose O.D. mm | Pressure Rating | | | | min. bend radius mm | weight kg |
|-------------|-----------|-------|------|------|-----------------|------------------------------|------|----------------------------|-------|------------------------|--------------|
| | DN | Inch | Size | mm | | max. working pressure MPa | psi | min. burst pressure MPa | psi | | |
| 426-4-RL | 6 | 1/4 | -4 | 6.4 | 13.4 | 19.2 | 2750 | 77.0 | 11000 | 100 | 0.24 |
| 426-6-RL | 10 | 3/8 | -6 | 9.5 | 17.4 | 15.7 | 2250 | 63.0 | 9000 | 125 | 0.34 |
| 426-8-RL | 12 | 1/2 | -8 | 12.7 | 20.7 | 14.0 | 2000 | 56.0 | 8000 | 180 | 0.43 |
| 426-10-RL | 16 | 5/8 | -10 | 15.9 | 23.9 | 10.5 | 1500 | 42.0 | 6000 | 200 | 0.49 |
| 426-12-RL | 19 | 3/4 | -12 | 19.1 | 27.8 | 8.7 | 1250 | 35.0 | 5075 | 240 | 0.65 |
| 426-16-RL | 25 | 1 | -16 | 25.4 | 35.8 | 7.0 | 1000 | 28.0 | 4000 | 300 | 0.98 |
| 426-20 | 31 | 1 1/4 | -20 | 31.8 | 45.0 | 4.3 | 625 | 17.2 | 2500 | 420 | 1.40 |
| 426-24 | 38 | 1 1/2 | -24 | 38.1 | 51.0 | 3.5 | 500 | 14.0 | 2000 | 500 | 1.46 |
| 426-32 | 51 | 2 | -32 | 50.8 | 64.0 | 2.6 | 375 | 10.4 | 1500 | 630 | 2.18 |

The combination of high temperature and high pressure could reduce the hose life.
RL = only available on reels.

Hose layline example

NO-SKIVE 426-8 WP 14,0 MPa (2000 PSI) MSHA XXXX SAE 100R1AT-8 HI-TEMP 12,5 mm (1/2) 1Q03



Cab-12

Catalogue 4400/UK

Medium Pressure
Low / High temperature

Parkrimp No-Skive Hose
436

436

No-Skive Compact

SAE 100R16 high temperature

Primary Applications

Medium pressure hydraulic applications at high temperature

Type Approvals

Details please find on pages **Ab-16** to **Ab-19**

Applicable Specifications

SAE 100R16

Construction

Inner tube: PKR synthetic rubber
Reinforcement: Two high-tensile steel wire braids
Cover: MSHA approved blue

Temperature Range -48 °C up to +150 °C

Exception: Air max. +70 °C
Water, water glycol fluids .. max. +85 °C



- **No-Skive** thin cover hose construction
- Compact hose construction with tight bend radius
- MSHA approved
- Ideal for high temperature applications

Recommended Fluids

Hydraulic fluids on a mineral-oil basis, water-glycol and lubricating oils, air and water.

Consult the chemical compatibility section on pages **Ab-26** to **Ab-34** for more detailed information.

Fitting Series



| Part Number | Hose I.D. | | | | Hose O.D. mm | Pressure Rating | | | | min. bend radius mm | weight kg |
|---------------|-----------|------|------|------|-----------------|------------------------------|------|----------------------------|-------|------------------------|--------------|
| | DN | Inch | Size | mm | | max. working pressure MPa | psi | min. burst pressure MPa | psi | | |
| 436-6-BLU-RL | 10 | 3/8 | -6 | 9.5 | 17.0 | 27.5 | 4000 | 110.0 | 16000 | 65 | 0.42 |
| 436-8-BLU-RL | 12 | 1/2 | -8 | 12.7 | 20.0 | 24.0 | 3500 | 96.0 | 14000 | 90 | 0.51 |
| 436-10-BLU-RL | 16 | 5/8 | -10 | 15.9 | 24.0 | 19.0 | 2750 | 76.0 | 11000 | 100 | 0.66 |
| 436-12-BLU-RL | 19 | 3/4 | -12 | 19.1 | 28.0 | 15.5 | 2250 | 62.0 | 9000 | 120 | 0.80 |
| 436-16-BLU-RL | 25 | 1 | -16 | 25.4 | 36.0 | 13.8 | 2000 | 55.0 | 8000 | 150 | 1.22 |

The combination of high temperature and high pressure could reduce the hose life.
RL = only available on reels.

Hose layline example



Cab-13

Catalogue 4400/UK

Hose

441

Elite No-Skive

ISO 11237 Type R16 – SAE 100R16

Primary Applications

Many industrial and mobile applications, with typical usage seen on agricultural machines or in power steering circuits

Applicable Specifications

ISO 11237 Type R16 – SAE 100R16

Construction

Inner tube: Synthetic rubber
Reinforcement: One high-tensile steel wire braid
Cover: Synthetic rubber

Temperature Range -40 °C up to +125 °C

Exception: Air max. +70 °C
Water max. +85 °C



- *No-Skive* hose construction
- One wire braid construction – two wire braid performance
- +125 °C working temperature

Recommended Fluids

Hydraulic fluids on a mineral-oil basis, water-glycol and lubricating oils, air and water. For air and gas applications with a pressure exceeding 1.7 MPa, the cover must be pin-pricked.

Consult the chemical compatibility section on pages **Ab-26** to **Ab-34** for more detailed information.

Fitting Series



| Part Number | Hose I.D. | | | | Hose O.D. mm | Pressure Rating | | | | min. bend radius mm | weight kg |
|-------------|-----------|------|------|------|-----------------|------------------------------|------|----------------------------|-------|------------------------|--------------|
| | DN | Inch | Size | mm | | max. working pressure MPa | psi | min. burst pressure MPa | psi | | |
| 441-4 | 6 | 1/4 | -4 | 6.4 | 13.4 | 35.0 | 5000 | 140.0 | 20000 | 50 | 0.27 |
| 441-5 | 8 | 5/16 | -5 | 7.9 | 15.0 | 29.7 | 4250 | 118.8 | 17000 | 55 | 0.32 |
| 441-6 | 10 | 3/8 | -6 | 9.5 | 17.4 | 28.0 | 4000 | 112.0 | 16000 | 65 | 0.42 |
| 441-8 | 12 | 1/2 | -8 | 12.7 | 20.7 | 24.5 | 3500 | 98.0 | 14000 | 90 | 0.50 |
| 441-10 | 16 | 5/8 | -10 | 15.9 | 23.8 | 19.2 | 2750 | 76.8 | 11000 | 100 | 0.65 |
| 441-12 | 19 | 3/4 | -12 | 19.1 | 27.8 | 15.7 | 2250 | 62.8 | 9000 | 120 | 0.80 |
| 441-16 | 25 | 1 | -16 | 25.4 | 35.8 | 14.0 | 2000 | 56.0 | 8000 | 150 | 1.22 |

The combination of high temperature and high pressure could reduce the hose life.
Also available on reels up to size -12 under part number 441-xx-RL

Hose layline example



441RH

No-Skive Compact
Fire-retardant cover

Primary Applications

General medium-pressure hydraulic and pneumatic systems as well as water and oil cooling circuits

Type Approvals

Details please find on pages **Ab-16** to **Ab-19**

Applicable Specifications

Parker Specification; Working pressure to SAE 100R2;
Bend radius to SAE 100R16

Construction

Inner tube: Synthetic rubber
Reinforcement: One high-tensile steel wire braid
Cover: Fire retardant synthetic rubber

Temperature Range -40 °C up to +125 °C

Exception: Air max. +70 °C
Water max. +85 °C



- **No-Skive** hose construction
- One wire braid construction – two wire braid performance
- +125 °C working temperature
- Fire-retardant cover
- Railway approved:
 - European Standard EN45545 HL2 for R22 (internal) and HL3 for R23 (external)
 - ISO 15540

Recommended Fluids

Hydraulic fluids on a mineral-oil basis, water-glycol and lubricating oils, air and water. For air and gas applications with a pressure exceeding 1.7 MPa, the cover must be pin-pricked. Consult the chemical compatibility section on pages **Ab-26** to **Ab-34** for more detailed information.

Fitting Series



Hose

| Part Number | Hose I.D. | | | | Hose O.D. mm | Pressure Rating | | | | min. bend radius mm | weight kg |
|-------------|-----------|------|------|------|-----------------|------------------------------|------|----------------------------|-------|------------------------|--------------|
| | DN | Inch | Size | mm | | max. working pressure MPa | psi | min. burst pressure MPa | psi | | |
| 441RH-4 | 6 | 1/4 | -4 | 6.4 | 13.4 | 35.0 | 5000 | 140.0 | 20000 | 50 | 0.27 |
| 441RH-5 | 8 | 5/16 | -5 | 7.9 | 15.0 | 29.7 | 4250 | 118.8 | 17000 | 55 | 0.32 |
| 441RH-6 | 10 | 3/8 | -6 | 9.5 | 17.4 | 28.0 | 4000 | 112.0 | 16000 | 65 | 0.42 |
| 441RH-8 | 12 | 1/2 | -8 | 12.7 | 20.7 | 24.5 | 3500 | 98.0 | 14000 | 90 | 0.50 |
| 441RH-10 | 16 | 5/8 | -10 | 15.9 | 23.8 | 19.2 | 2750 | 76.8 | 11000 | 100 | 0.65 |
| 441RH-12 | 19 | 3/4 | -12 | 19.1 | 27.8 | 15.7 | 2250 | 62.8 | 9000 | 120 | 0.80 |
| 441RH-16 | 25 | 1 | -16 | 25.4 | 35.8 | 14.0 | 2000 | 56.0 | 8000 | 150 | 1.22 |

The combination of high temperature and high pressure could reduce the hose life.

Hose layline example

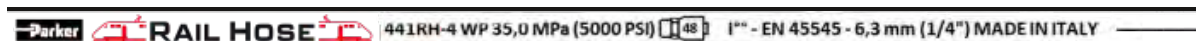

Cab-15

Catalogue 4400/UK

Medium Pressure
Low / High temperature

Parkrimp No-Skive Hose
461LT

461LT

Elite No-Skive Compact

EN 857 2SC low temperature



- *No-Skive* thin cover hose construction
- Excellent ozone resistance
- Ideal for low temperature working conditions (-50 °C)

Primary Applications

Mobile applications in low temperature environments:
Forestry machines, refrigerated warehouses

Applicable Specifications

EN 857 2SC

Construction

Inner tube: Synthetic rubber
Reinforcement: Two high-tensile steel wire braids
Cover: Synthetic rubber

Temperature Range -50 °C up to +100 °C

Exception: Air max. +70 °C
Water max. +85 °C

Recommended Fluids

Hydraulic fluids on a mineral-oil basis, water-glycol and lubricating oils, air and water. For air and gas applications with a pressure exceeding 1.7 MPa, the cover must be pin-pricked.

Consult the chemical compatibility section on pages **Ab-26** to **Ab-34** for more detailed information.

Fitting Series



| Part Number | Hose I.D. | | | | Hose O.D. mm | Pressure Rating | | | | min. bend radius mm | weight kg |
|-------------|-----------|------|------|------|-----------------|------------------------------|------|----------------------------|-------|------------------------|--------------|
| | DN | Inch | Size | mm | | max. working pressure MPa | psi | min. burst pressure MPa | psi | | |
| 461LT-4 | 6 | 1/4 | -4 | 6.4 | 13 | 42.5 | 6160 | 170.0 | 24640 | 75 | 0.30 |
| 461LT-5 | 8 | 5/16 | -5 | 7.9 | 15 | 40.0 | 5800 | 160.0 | 23200 | 85 | 0.35 |
| 461LT-6 | 10 | 3/8 | -6 | 9.5 | 17 | 35.0 | 5075 | 140.0 | 20300 | 90 | 0.42 |
| 461LT-8 | 12 | 1/2 | -8 | 12.7 | 21 | 31.0 | 4495 | 124.0 | 17980 | 130 | 0.52 |
| 461LT-10 | 16 | 5/8 | -10 | 15.9 | 24 | 28.0 | 4060 | 112.0 | 16240 | 160 | 0.66 |
| 461LT-12 | 19 | 3/4 | -12 | 19.1 | 28 | 28.0 | 4060 | 112.0 | 16240 | 195 | 0.86 |
| 461LT-16 | 25 | 1 | -16 | 25.4 | 35 | 21.0 | 3045 | 84.0 | 12180 | 250 | 1.17 |

The combination of high temperature and high pressure could reduce the hose life.

Hose layline example



Cab-16

Catalogue 4400/UK

462

Elite No-Skive Compact

Exceeds EN 857-2SC – ISO 11237 Type 2SC

Primary Applications

Demanding medium pressure hydraulic applications in all markets

Type Approvals

Details please find on pages **Ab-16** to **Ab-19**

Applicable Specifications

Exceed EN 857-2SC – ISO 11237 Type 2SC

Construction

- Inner tube: Nitrile (NBR)
- Reinforcement: Two high-tensile steel wire braids
- Cover: Synthetic rubber

Temperature Range -40 °C up to +100 °C

- Exception: Air max. +70 °C
- Water max. +85 °C

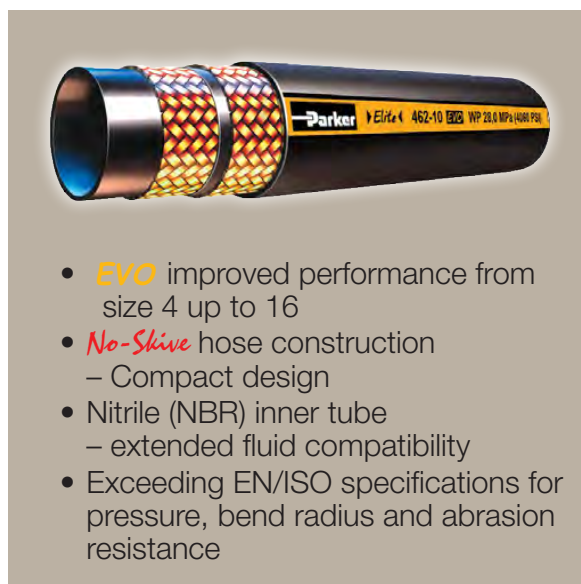

- **EVO** improved performance from size 4 up to 16
- **No-Skive** hose construction – Compact design
- Nitrile (NBR) inner tube – extended fluid compatibility
- Exceeding EN/ISO specifications for pressure, bend radius and abrasion resistance

Recommended Fluids

Hydraulic fluids on a mineral-oil basis, water-glycol and lubricating oils, air and water. For air and gas applications with a pressure exceeding 1.7 MPa, the cover must be pin-pricked. Consult the chemical compatibility section on pages **Ab-26** to **Ab-34** for more detailed information.

Fitting Series

Size -4 up to -16

Size -20



Hose

| Part Number | Hose I.D. | | | | Hose O.D. mm | Pressure Rating | | | | min. bend radius mm | weight kg |
|-------------------|-----------|-------|------|------|-----------------|------------------------------|------|----------------------------|-------|------------------------|--------------|
| | DN | Inch | Size | mm | | max. working pressure MPa | psi | min. burst pressure MPa | psi | | |
| EVO 462-4 | 6 | 1/4 | -4 | 6.4 | 13.4 | 42.5 | 6160 | 170.0 | 24640 | 50 | 0.30 |
| EVO 462-5 | 8 | 5/16 | -5 | 7.9 | 15.0 | 40.0 | 5800 | 160.0 | 23200 | 55 | 0.35 |
| EVO 462-6 | 10 | 3/8 | -6 | 9.5 | 17.2 | 35.0 | 5075 | 140.0 | 20300 | 65 | 0.42 |
| EVO 462-8 | 12 | 1/2 | -8 | 12.7 | 20.4 | 31.0 | 4495 | 124.0 | 17980 | 80 | 0.52 |
| EVO 462-10 | 16 | 5/8 | -10 | 15.9 | 23.9 | 28.0 | 4060 | 112.0 | 16240 | 100 | 0.66 |
| EVO 462-12 | 19 | 3/4 | -12 | 19.1 | 27.7 | 28.0 | 4060 | 112.0 | 16240 | 120 | 0.86 |
| EVO 462-16 | 25 | 1 | -16 | 25.4 | 35.4 | 21.0 | 3045 | 84.0 | 12180 | 150 | 1.17 |
| 462-20 | 31 | 1 1/4 | -20 | 31.8 | 45.1 | 17.2 | 2495 | 68.8 | 9980 | 335 | 1.80 |

The combination of high temperature and high pressure could reduce the hose life.
From size -4 to -16, smooth cover, 462-20 wrapped cover
Also available in reels up to size -12 under part number 462-xx-RL

Hose layline example



Medium Pressure
Polyurethane Cover

Parkrimp No-Skive Hose
462PU

462PU

No-Skive Compact
Polyurethane Cover

Primary Applications

For truck cranes and lifting equipment such as forklift trucks, aerial lifts, cranes, telehandlers, lifting platforms. Ideal for over-the-sheave or reel applications. The best solution for all the demanding medium pressure hydraulic applications in all markets, especially mobile and construction equipment.

Applicable Specifications

Exceed EN 857 2SC - ISO 11237 type 2SC

Construction

Inner tube: Nitrile (NBR)
Reinforcement: Two high-tensile steel wire braids
Cover: Premium-quality polyurethane

Temperature Range -50 °C up to +100 °C

Exception: Air max. +70 °C
Water max. +85 °C

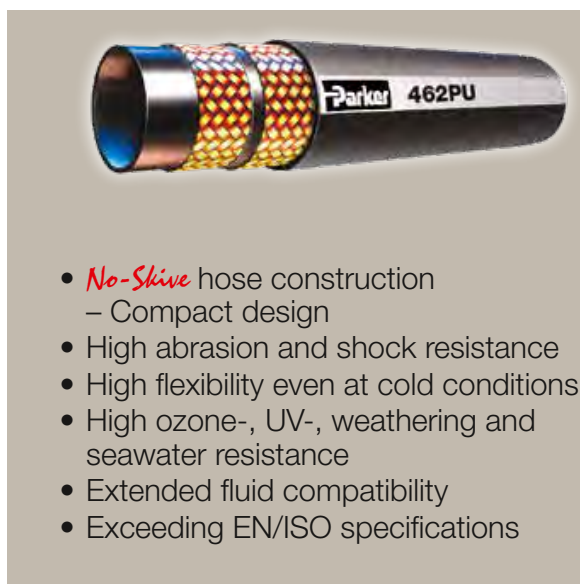

- *No-Skive* hose construction – Compact design
- High abrasion and shock resistance
- High flexibility even at cold conditions
- High ozone-, UV-, weathering and seawater resistance
- Extended fluid compatibility
- Exceeding EN/ISO specifications

Recommended Fluids

Hydraulic fluids on a mineral-oil basis, water-glycol and lubricating oils, air and water. For air and gas applications with a pressure exceeding 1.7 MPa, the cover must be pin-pricked.

Consult the chemical compatibility section on pages **Ab-26** to **Ab-34** for more detailed information.

Fitting Series



| Part Number | Hose I.D. | | | | Hose O.D. mm | Pressure Rating | | | | min. bend radius mm | weight kg |
|-------------|-----------|------|------|------|-----------------|------------------------------|------|----------------------------|-------|------------------------|--------------|
| | DN | Inch | Size | mm | | max. working pressure MPa | psi | min. burst pressure MPa | psi | | |
| 462PU-4 | 6 | 1/4 | -4 | 6,4 | 13,4 | 42,5 | 6160 | 170,0 | 24640 | 75 | 0,30 |
| 462PU-5 | 8 | 5/16 | -5 | 7,9 | 15,0 | 40,0 | 5800 | 160,0 | 23200 | 85 | 0,35 |
| 462PU-6 | 10 | 3/8 | -6 | 9,5 | 17,2 | 35,0 | 5075 | 140,0 | 20300 | 90 | 0,42 |
| 462PU-8 | 12 | 1/2 | -8 | 12,7 | 20,4 | 31,0 | 4495 | 124,0 | 17980 | 130 | 0,52 |
| 462PU-10 | 16 | 5/8 | -10 | 15,9 | 23,9 | 28,0 | 4060 | 112,0 | 16240 | 160 | 0,66 |

The combination of high temperature and high pressure could reduce the hose life.

Hose layline example

PARKER ELITE 462PU-8 WP 31,0 MPa (4495 psi) | • • 12,5 mm (1/2 ")



Cab-18

Catalogue 4400/UK

Medium Pressure
Polyurethane Cover

Parkrimp No-Skive Hose
462PU Twin

462PU Twin

No-Skive Compact

Twin Hose with Polyurethane Cover

Primary Applications

For truck cranes and lifting equipment such as forklift trucks, aerial lifts, cranes, telehandlers, lifting platforms. Ideal for over-the-sheave or reel applications. The best solution for all the demanding medium pressure hydraulic applications in all markets, especially mobile and construction equipment.

Applicable Specifications

Exceed EN 857 2SC - ISO 11237 type 2SC

Construction

Inner tube: Nitrile (NBR)
Reinforcement: Two high-tensile steel wire braids
Cover: Premium-quality polyurethane

Temperature Range -50 °C up to +100 °C

Exception: Air max. +70 °C

Water max. +85 °C



- *No-Skive* hose construction – Compact design
- High abrasion and shock resistance
- High flexibility even at cold conditions
- High ozone-, UV-, weathering and seawater resistance
- Extended fluid compatibility
- Exceeding EN/ISO specifications

Recommended Fluids

Hydraulic fluids on a mineral-oil basis, water-glycol and lubricating oils, air and water. For air and gas applications with a pressure exceeding 1.7 MPa, the cover must be pin-pricked.

Consult the chemical compatibility section on pages **Ab-26** to **Ab-34** for more detailed information.

Fitting Series



| Part Number | Hose I.D. | | | | Hose O.D. mm | Pressure Rating | | | | min. bend radius mm | weight kg |
|-------------|-----------|------|------|------|-----------------|------------------------------|------|----------------------------|-------|------------------------|--------------|
| | DN | Inch | Size | mm | | max. working pressure MPa | psi | min. burst pressure MPa | psi | | |
| 462PU-4-4 | 6 | 1/4 | -4 | 6.4 | 28.2 | 42.5 | 6160 | 170.0 | 24640 | 75 | 0.60 |
| 462PU-5-5 | 8 | 5/16 | -5 | 7.9 | 32.5 | 40.0 | 5800 | 160.0 | 23200 | 85 | 0.70 |
| 462PU-6-6 | 10 | 3/8 | -6 | 9.5 | 35.0 | 35.0 | 5075 | 140.0 | 20300 | 90 | 0.85 |
| 462PU-8-8 | 12 | 1/2 | -8 | 12.7 | 41.5 | 31.0 | 4495 | 124.0 | 17980 | 130 | 1.00 |
| 462PU-10-10 | 16 | 5/8 | -10 | 15.9 | 48.7 | 28.0 | 4060 | 112.0 | 16240 | 160 | 1.35 |

The combination of high temperature and high pressure could reduce the hose life.

Hose layline example

PARKER ELITE 462PU-8-8 WP 31,0 MPa (4495 psi) | • • 12,5 mm (1/2 ")



Cab-19

Catalogue 4400/UK

Hose

Medium Pressure
High abrasion resistance

Parkrimp No-Skive Hose
462TC

462TC

Elite No-Skive Compact Tough Cover
Exceeds EN 857-2SC – ISO 11237 Type 2SC

Primary Applications

Demanding medium pressure hydraulic applications in all markets

Type Approvals

Details please find on pages **Ab-16** to **Ab-19**

Applicable Specifications

Exceed EN 857-2SC – ISO 11237 Type 2SC

Construction

Inner tube: Nitrile (NBR)
Reinforcement: Two high-tensile steel wire braids
Cover: Highly abrasion resistance
MSHA approved

Temperature Range -40 °C up to +100 °C

Exception: Air max. +70 °C
Water max. +85 °C

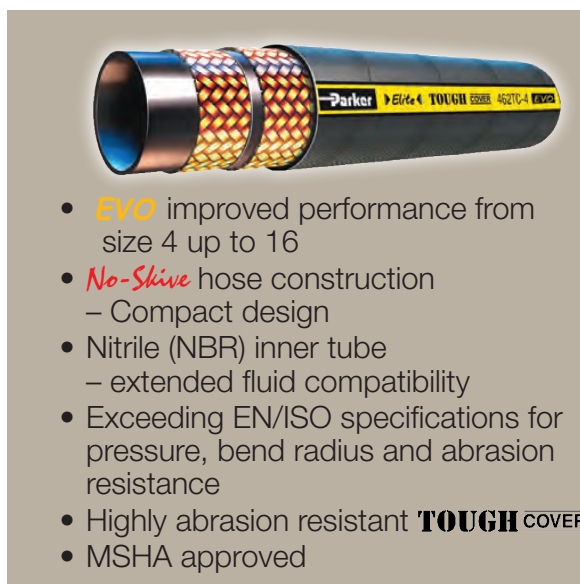

- **EVO** improved performance from size 4 up to 16
- **No-Skive** hose construction – Compact design
- Nitrile (NBR) inner tube – extended fluid compatibility
- Exceeding EN/ISO specifications for pressure, bend radius and abrasion resistance
- Highly abrasion resistant **TOUGH COVER**
- MSHA approved

Recommended Fluids

Hydraulic fluids on a mineral-oil basis, water-glycol and lubricating oils, air and water. For air and gas applications with a pressure exceeding 1.7 MPa, the cover must be pin-pricked. Consult the chemical compatibility section on pages **Ab-26** to **Ab-34** for more detailed information.

Fitting Series

Size -4 up to -16



Size -20 up to -32

Size -40 up to -48

2piece 48

| Part Number | Hose I.D. | | | | Hose O.D. mm | Pressure Rating | | | | min. bend radius mm | weight kg |
|---------------------|-----------|-------|------|------|-----------------|------------------------------|------|----------------------------|-------|------------------------|--------------|
| | DN | Inch | Size | mm | | max. working pressure MPa | psi | min. burst pressure MPa | psi | | |
| EVO 462TC-4 | 6 | 1/4 | -4 | 6.4 | 13.4 | 42.5 | 6160 | 170.0 | 24640 | 50 | 0.30 |
| EVO 462TC-5 | 8 | 5/16 | -5 | 7.9 | 15.0 | 40.0 | 5800 | 160.0 | 23200 | 55 | 0.35 |
| EVO 462TC-6 | 10 | 3/8 | -6 | 9.5 | 17.2 | 35.0 | 5075 | 140.0 | 20300 | 65 | 0.42 |
| EVO 462TC-8 | 12 | 1/2 | -8 | 12.7 | 20.4 | 31.0 | 4495 | 124.0 | 17980 | 80 | 0.52 |
| EVO 462TC-10 | 16 | 5/8 | -10 | 15.9 | 23.9 | 28.0 | 4060 | 112.0 | 16240 | 100 | 0.66 |
| EVO 462TC-12 | 19 | 3/4 | -12 | 19.1 | 27.7 | 28.0 | 4060 | 112.0 | 16240 | 120 | 0.86 |
| EVO 462TC-16 | 25 | 1 | -16 | 25.4 | 35.4 | 21.0 | 3045 | 84.0 | 12180 | 150 | 1.17 |
| 462TC-20 * | 31 | 1 1/4 | -20 | 31.8 | 45.1 | 17.2 | 2495 | 68.8 | 9980 | 335 | 1.80 |
| 462TC-24 * | 38 | 1 1/2 | -24 | 38.1 | 52.0 | 14.6 | 2118 | 58.4 | 8472 | 400 | 2.20 |
| 462TC-32 * | 51 | 2 | -32 | 50.8 | 64.0 | 11.2 | 1624 | 44.8 | 6496 | 500 | 2.90 |
| 462TC-40 ** | 63 | 2 1/2 | -40 | 63.5 | 76.0 | 7.0 | 1015 | 28.0 | 4060 | 760 | 3.00 |
| 462TC-48 ** | 76 | 3 | -48 | 76.2 | 87.5 | 7.0 | 1015 | 28.0 | 4060 | 760 | 3.30 |

The combination of high temperature and high pressure could reduce the hose life.

* Size -20 up to -32 only with fitting series 48

** Size -40 up to -48 only with 2piece fitting series 48

Hose layline example

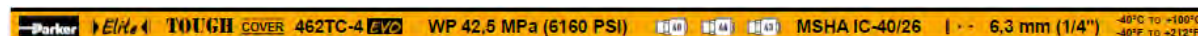

Cab-20

Catalogue 4400/UK

Medium Pressure
Extreme abrasion resistance

Parkrimp No-Skive Hose
462ST

462ST

Elite *No-Skive* **Super Tough Compact**

EN 857 2SC – ISO 11237 Type 2SC

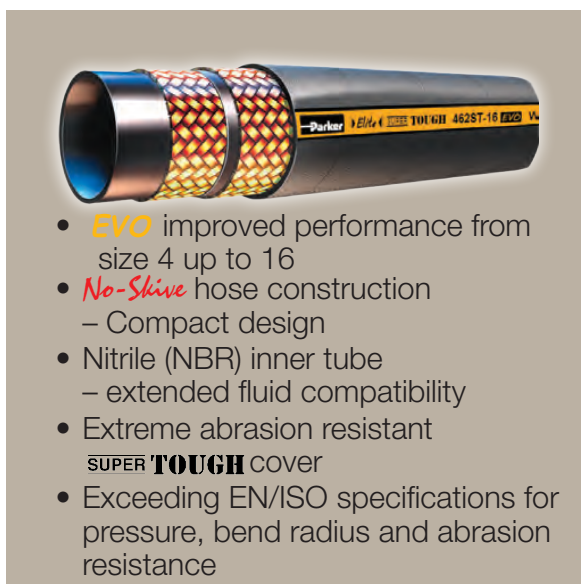

- **EVO** improved performance from size 4 up to 16
- *No-Skive* hose construction – Compact design
- Nitrile (NBR) inner tube – extended fluid compatibility
- Extreme abrasion resistant **SUPER TOUGH** cover
- Exceeding EN/ISO specifications for pressure, bend radius and abrasion resistance

Primary Applications

Mobile market: Medium pressure hydraulic applications with extremely high abrasion risks

Applicable Specifications

EN 857 2SC – ISO 11237 Type 2SC

Construction

Inner tube: Nitrile (NBR)
Reinforcement: Two high-tensile steel wire braids
Cover: Synthetic rubber with a special polyethylene coating

Temperature Range -40 °C up to +100 °C

Exception: Air max. +70 °C
Water max. +85 °C

Recommended Fluids

Hydraulic fluids on a mineral-oil basis, water-glycol and lubricating oils, air and water. For air and gas applications with a pressure exceeding 1.7 MPa, the cover must be pin-pricked. Consult the chemical compatibility section on pages **Ab-26** to **Ab-34** for more detailed information.

Fitting Series

Size -4 up to -16

Size -20



Hose

| Part Number | Hose I.D. | | | | Hose O.D. mm | Pressure Rating | | | | min. bend radius mm | weight kg |
|---------------------|-----------|-------|------|------|-----------------|------------------------------|------|----------------------------|-------|------------------------|--------------|
| | DN | Inch | Size | mm | | max. working pressure MPa | psi | min. burst pressure MPa | psi | | |
| EVO 462ST-4 | 6 | 1/4 | -4 | 6.4 | 13.4 | 42.5 | 6160 | 170.0 | 24640 | 50 | 0.30 |
| EVO 462ST-5 | 8 | 5/16 | -5 | 7.9 | 15.0 | 40.0 | 5800 | 160.0 | 23200 | 55 | 0.35 |
| EVO 462ST-6 | 10 | 3/8 | -6 | 9.5 | 17.2 | 35.0 | 5075 | 140.0 | 20300 | 65 | 0.42 |
| EVO 462ST-8 | 12 | 1/2 | -8 | 12.7 | 20.4 | 31.0 | 4495 | 124.0 | 17980 | 80 | 0.52 |
| EVO 462ST-10 | 16 | 5/8 | -10 | 15.9 | 23.9 | 28.0 | 4060 | 112.0 | 16240 | 100 | 0.66 |
| EVO 462ST-12 | 19 | 3/4 | -12 | 19.1 | 27.7 | 28.0 | 4060 | 112.0 | 16240 | 120 | 0.86 |
| EVO 462ST-16 | 25 | 1 | -16 | 25.4 | 35.4 | 21.0 | 3045 | 84.0 | 12180 | 150 | 1.17 |
| 462ST-20 * | 31 | 1 1/4 | -20 | 31.8 | 45.1 | 17.2 | 2495 | 68.8 | 9980 | 335 | 1.80 |

The combination of high temperature and high pressure could reduce the hose life.

* 462ST-20 only with fitting series 48

Hose layline example

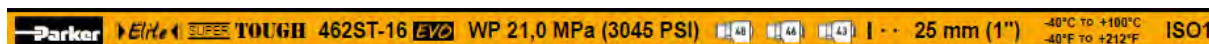

Cab-21

Catalogue 4400/UK

463

No-Skive Compact

High pressure water cleaning applications



- 2 wire *No-Skive* Compact design
- For water up to +120 °C constant temperature

Primary Applications

High pressure water cleaners

Construction

Inner tube: Synthetic rubber
Reinforcement: Two high-tensile steel wire braids
Cover: Synthetic rubber , black or blue

Temperature RangeWater max. +120 °C

Fitting Series



| Part Number | Hose I.D. | | | | Hose O.D. mm | Pressure Rating | | | | min. bend radius mm | weight kg |
|-------------|-----------|------|------|------|-----------------|------------------------------|------|----------------------------|-------|------------------------|--------------|
| | DN | Inch | Size | mm | | max. working pressure MPa | psi | min. burst pressure MPa | psi | | |
| 463-5 | 8 | 5/16 | -5 | 7.9 | 15.0 | 40.0 | 5800 | 120.0 | 17400 | 75 | 0.31 |
| 463-5-BLU | 8 | 5/16 | -5 | 7.9 | 15.0 | 40.0 | 5800 | 120.0 | 17400 | 75 | 0.31 |
| 463-6 | 10 | 3/8 | -6 | 9.5 | 17.4 | 40.0 | 5800 | 120.0 | 17400 | 90 | 0.38 |
| 463-6-BLU | 10 | 3/8 | -6 | 9.5 | 17.4 | 40.0 | 5800 | 120.0 | 17400 | 90 | 0.38 |
| 463-8 | 12 | 1/2 | -8 | 12.7 | 20.6 | 35.0 | 5075 | 105.0 | 15225 | 110 | 0.48 |
| 463-8-BLU | 12 | 1/2 | -8 | 12.7 | 20.6 | 35.0 | 5075 | 105.0 | 15225 | 110 | 0.48 |

WKS rubber hand grip for No-Skive high pressure water cleaning hoses can be found on page Eb-20.
The combination of high temperature and high pressure could reduce the hose life.
Also available on reels under part number 463-xx-RL

Hose layline example



Medium Pressure
High abrasion resistance

Parkrimp No-Skive Hose
471TC

471TC

No-Skive

EN 857 2SC – ISO 11237 Type 2SC

Primary Applications

Small bending radii demanding medium pressure hydraulic applications

Type Approvals

Details please find on pages **Ab-16** to **Ab-19**

Applicable Specifications

EN 857 2SC – ISO 11237 Type 2SC

Construction

Inner tube: Synthetic rubber
Reinforcement: Two high-tensile steel wire braids
Cover: Highly abrasion resistance
MSHA approved

Temperature Range -40 °C up to +100 °C

Exception: Air max. +70 °C
Water max. +85 °C



- *No-Skive* hose construction – Compact design
- Reduced bend radii
- Highly abrasion resistant **TOUGH COVER**
- MSHA approved
- Hose is suitable for temporary immersion in mineral oil up to 70 °C with frequent inspections

Recommended Fluids

Hydraulic fluids on a mineral-oil basis, water-glycol and lubricating oils, air and water. For air and gas applications with a pressure exceeding 1.7 MPa, the cover must be pin-pricked.

Consult the chemical compatibility section on pages **Ab-26** to **Ab-34** for more detailed information.

Fitting Series



Hose

| Part Number | Hose I.D. | | | | Hose O.D. mm | Pressure Rating | | | | min. bend radius mm | weight kg |
|-------------|-----------|------|------|------|-----------------|------------------------------|------|----------------------------|-------|------------------------|--------------|
| | DN | Inch | Size | mm | | max. working pressure MPa | psi | min. burst pressure MPa | psi | | |
| 471TC-4 | 6 | 1/4 | -4 | 6.4 | 13 | 40.0 | 5800 | 160.0 | 23200 | 50 | 0.30 |
| 471TC-5 | 8 | 5/16 | -5 | 7.9 | 15 | 36.0 | 5250 | 144.0 | 21000 | 55 | 0.35 |
| 471TC-6 | 10 | 3/8 | -6 | 9.5 | 17 | 35.0 | 5075 | 140.0 | 20000 | 65 | 0.42 |
| 471TC-8 | 12 | 1/2 | -8 | 12.7 | 20 | 29.7 | 4250 | 119.0 | 17000 | 90 | 0.52 |
| 471TC-10 | 16 | 5/8 | -10 | 15.9 | 24 | 25.0 | 3625 | 100.0 | 14500 | 100 | 0.66 |
| 471TC-12 | 19 | 3/4 | -12 | 19.1 | 28 | 21.5 | 3125 | 86.0 | 12500 | 120 | 0.86 |
| 471TC-16 | 25 | 1 | -16 | 25.4 | 35 | 17.5 | 2500 | 70.0 | 10000 | 150 | 1.17 |

Replace the hose when any deformation or damages on the hose cover are visible.
The combination of high temperature and high pressure could reduce the hose life.

Hose layline example

Parker TOUGH COVER 471TC-8 WP 29,7 MPa (4250 PSI) MSHA IC-40/26 — — — — ISO11237/EN



Cab-23

Catalogue 4400/UK

477

Elite No-Skive PowerLift

2 wire braided

Primary Applications

For truck cranes and lifting equipment such as fork lift trucks, aerial lifts, cranes, telehandlers, lifting platforms.

Restrictions

Should not be used for high impulse hydraulic applications to replace spiral construction hoses.

Construction

Inner tube: Nitrile (NBR)
Reinforcement: Two high-tensile steel wire braids
Cover: Synthetic rubber

Temperature Range -40 °C up to +100 °C

Exception: Air max. +70 °C
Water max. +85 °C



- **No-Skive** hose construction – Compact design
- Smaller bend radius and reduced outside diameter bringing a significant advantage in terms of space and weight on compact equipment

Recommended Fluids

Hydraulic fluids on a mineral-oil basis, water-glycol and lubricating oils, air and water. For air and gas applications with a pressure exceeding 1.7 MPa, the cover must be pin-pricked.

Consult the chemical compatibility section on pages **Ab-26** to **Ab-34** for more detailed information.

Fitting Series



| Part Number | Hose I.D. | | | | Hose O.D. mm | Pressure Rating | | | | min. bend radius mm | weight kg |
|-------------|-----------|------|------|------|-----------------|------------------------------|------|----------------------------|-------|------------------------|--------------|
| | DN | Inch | Size | mm | | max. working pressure MPa | psi | min. burst pressure MPa | psi | | |
| 477-4 | 6 | 1/4 | -4 | 6.4 | 13.1 | 45.0 | 6500 | 180.0 | 26000 | 65 | 0.32 |
| 477-5 | 8 | 5/16 | -5 | 7.9 | 14.9 | 42.5 | 6100 | 170.0 | 24400 | 70 | 0.35 |
| 477-6 | 10 | 3/8 | -6 | 9.5 | 17.2 | 40.0 | 5800 | 160.0 | 23200 | 75 | 0.42 |
| 477-8 | 12 | 1/2 | -8 | 12.7 | 20.4 | 38.0 | 5500 | 152.0 | 22000 | 105 | 0.55 |
| 477-10 | 16 | 5/8 | -10 | 15.9 | 23.4 | 35.0 | 5000 | 140.0 | 20000 | 160 | 0.65 |
| 477-12 | 19 | 3/4 | -12 | 19.1 | 27.2 | 35.0 | 5000 | 140.0 | 20000 | 200 | 1.10 |
| 477-16 | 25 | 1 | -16 | 25.4 | 34.8 | 28.0 | 4000 | 112.0 | 16000 | 250 | 1.34 |

The combination of high temperature and high pressure could reduce the hose life.

Hose layline example



477RH

Elite No-Skive

2 wire braided with fire-retardant cover

Primary Applications

For general medium pressure hydraulic and demanding bending radii applications such as lifting equipment.

Type Approvals

Details please find on pages **Ab-16** to **Ab-19**

Restrictions

Should not be used for high impulse hydraulic applications to replace spiral construction hoses.

Construction

Inner Tube: Nitrile (NBR)
Reinforcement: Two high-tensile steel wire braids
Cover: Fire retardant synthetic rubber

Temperature Range -40 °C up to +100 °C

Exception: Air max. +70 °C
Water max. +85 °C



- *No-Skive* hose construction – Compact design
- Smaller bend radius and reduced outside diameter
- Fire-retardant cover
- Railway approved:
 - European Standard EN45545 HL2 for R22 (internal) and HL3 for R23 (external)

Recommended Fluids

Hydraulic fluids on a mineral-oil basis, water-glycol and lubricating oils, air and water. For air and gas applications with a pressure exceeding 1.7 MPa, the cover must be pin-pricked.

Consult the chemical compatibility section on pages **Ab-26** to **Ab-34** for more detailed information.

Fitting Series



| Part Number | Hose I.D. | | | | Hose O.D. mm | Pressure Rating | | | | min. bend radius mm | weight kg |
|-------------|-----------|------|------|------|-----------------|------------------------------|------|----------------------------|-------|------------------------|--------------|
| | DN | Inch | Size | mm | | max. working pressure MPa | psi | min. burst pressure MPa | psi | | |
| 477RH-4 | 6 | 1/4 | -4 | 6.4 | 13.1 | 45.0 | 6500 | 180.0 | 26000 | 65 | 0.32 |
| 477RH-5 | 8 | 5/16 | -5 | 7.9 | 14.9 | 42.5 | 6100 | 170.0 | 24400 | 70 | 0.35 |
| 477RH-6 | 10 | 3/8 | -6 | 9.5 | 17.2 | 40.0 | 5800 | 160.0 | 23200 | 75 | 0.42 |
| 477RH-8 | 12 | 1/2 | -8 | 12.7 | 20.4 | 38.0 | 5500 | 152.0 | 22000 | 105 | 0.55 |
| 477RH-10 | 16 | 5/8 | -10 | 15.9 | 23.4 | 35.0 | 5000 | 140.0 | 20000 | 160 | 0.65 |
| 477RH-12 | 19 | 3/4 | -12 | 19.1 | 27.2 | 35.0 | 5000 | 140.0 | 20000 | 200 | 1.10 |
| 477RH-16 | 25 | 1 | -16 | 25.4 | 34.8 | 28.0 | 4000 | 112.0 | 16000 | 250 | 1.34 |

The combination of high temperature and high pressure could reduce the hose life.

Hose layline example

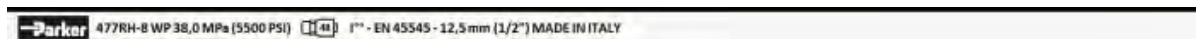

477TC

Elite No-Skive PowerLift Tough Cover
2 wire braided

Primary Applications

For truck cranes and lifting equipment such as fork lift trucks, aerial lifts, cranes, telehandlers, lifting platforms.

Restrictions

Should not be used for high impulse hydraulic applications to replace spiral construction hoses.

Construction

Inner tube: Nitrile (NBR)
Reinforcement: Two high-tensile steel wire braids
Cover: Highly abrasion resistance
MSHA approved

Temperature Range -40 °C up to +100 °C

Exception: Air max. +70 °C
Water max. +85 °C



- *No-Skive* hose construction – Compact design
- Smaller bend radius and reduced outside diameter bringing a significant advantage in terms of space and weight on compact equipment
- Highly abrasion resistant **TOUGH COVER**
- MSHA approved
- Hose is suitable for temporary immersion in mineral oil up to 70 °C with frequent inspections

Recommended Fluids

Hydraulic fluids on a mineral-oil basis, water-glycol and lubricating oils, air and water. For air and gas applications with a pressure exceeding 1.7 MPa, the cover must be pin-pricked.

Consult the chemical compatibility section on pages **Ab-26** to **Ab-34** for more detailed information.

Fitting Series



| Part Number | Hose I.D. | | | | Hose O.D. mm | Pressure Rating | | | | min. bend radius mm | weight kg |
|-------------|-----------|------|------|------|-----------------|------------------------------|------|----------------------------|-------|------------------------|--------------|
| | DN | Inch | Size | mm | | max. working pressure MPa | psi | min. burst pressure MPa | psi | | |
| 477TC-4 | 6 | 1/4 | -4 | 6.4 | 13.1 | 45.0 | 6500 | 180.0 | 26000 | 65 | 0.32 |
| 477TC-5 | 8 | 5/16 | -5 | 7.9 | 14.9 | 42.5 | 6100 | 170.0 | 24400 | 70 | 0.35 |
| 477TC-6 | 10 | 3/8 | -6 | 9.5 | 17.2 | 40.0 | 5800 | 160.0 | 23200 | 75 | 0.42 |
| 477TC-8 | 12 | 1/2 | -8 | 12.7 | 20.4 | 38.0 | 5500 | 152.0 | 22000 | 105 | 0.55 |
| 477TC-10 | 16 | 5/8 | -10 | 15.9 | 23.4 | 35.0 | 5000 | 140.0 | 20000 | 160 | 0.65 |
| 477TC-12 | 19 | 3/4 | -12 | 19.1 | 27.2 | 35.0 | 5000 | 140.0 | 20000 | 200 | 1.10 |
| 477TC-16 | 25 | 1 | -16 | 25.4 | 34.8 | 28.0 | 4000 | 112.0 | 16000 | 250 | 1.34 |

The combination of high temperature and high pressure could reduce the hose life.

Hose layline example



477ST

Elite No-Skive PowerLift

2 wire braided

Primary Applications

For truck cranes and lifting equipment such as fork lift trucks, aerial lifts, cranes, telehandlers, lifting platforms.

Restrictions

Should not be used for high impulse hydraulic applications to replace spiral construction hoses.

Construction

- Inner tube: Nitrile (NBR)
- Reinforcement: Two high-tensile steel wire braids
- Cover: Synthetic rubber with a special polyethylene coating

Temperature Range -40 °C up to +100 °C

- Exception: Air max. +70 °C
- Water max. +85 °C



- *No-Skive* hose construction – Compact design
- Extreme abrasion resistant **SUPER TOUGH** cover
- Smaller bend radius and reduced outside diameter

Recommended Fluids

Hydraulic fluids on a mineral-oil basis, water-glycol and lubricating oils, air and water. For air and gas applications with a pressure exceeding 1.7 MPa, the cover must be pin-pricked.

Consult the chemical compatibility section on pages **Ab-26** to **Ab-34** for more detailed information.

Fitting Series



Hose

| Part Number | Hose I.D. | | | | Hose O.D. mm | Pressure Rating | | | | min. bend radius mm | weight kg |
|-------------|-----------|------|------|------|-----------------|------------------------------|------|----------------------------|-------|------------------------|--------------|
| | DN | Inch | Size | mm | | max. working pressure MPa | psi | min. burst pressure MPa | psi | | |
| 477ST-4 | 6 | 1/4 | -4 | 6.4 | 13.1 | 45.0 | 6500 | 180.0 | 26000 | 65 | 0.30 |
| 477ST-5 | 8 | 5/16 | -5 | 7.9 | 14.9 | 42.5 | 6100 | 170.0 | 24400 | 70 | 0.35 |
| 477ST-6 | 10 | 3/8 | -6 | 9.5 | 17.2 | 40.0 | 5800 | 160.0 | 23200 | 75 | 0.42 |
| 477ST-8 | 12 | 1/2 | -8 | 12.7 | 20.4 | 38.0 | 5500 | 152.0 | 22000 | 105 | 0.55 |
| 477ST-10 | 16 | 5/8 | -10 | 15.9 | 23.4 | 35.0 | 5000 | 140.0 | 20000 | 160 | 0.65 |
| 477ST-12 | 19 | 3/4 | -12 | 19.1 | 27.2 | 35.0 | 5000 | 140.0 | 20000 | 200 | 1.20 |
| 477ST-16 | 25 | 1 | -16 | 25.4 | 34.8 | 28.0 | 4000 | 112.0 | 16000 | 250 | 1.34 |

The combination of high temperature and high pressure could reduce the hose life.

Hose layline example



492

Elite No-Skive Compact

EN 857 1SC – ISO 11237 Type 1SC

Primary Applications

Demanding medium pressure hydraulic applications

Type Approvals

Details please find on pages **Ab-16** to **Ab-19**

Applicable Specifications

EN 857 1SC – ISO 11237 Type 1SC

Construction

Inner tube: Nitrile (NBR)
Reinforcement: One high-tensile steel wire braid
Cover: Synthetic rubber

Temperature Range -40 °C up to +100 °C

Exception: Air max. +70 °C
Water max. +85 °C



- **No-Skive** hose construction – Compact design
- Nitrile (NBR) inner tube – extended fluid compatibility
- Exceeding EN/ISO specifications for pressure, bend radius and abrasion resistance

Recommended Fluids

Hydraulic fluids on a mineral-oil basis, water-glycol and lubricating oils, air and water. For air and gas applications with a pressure exceeding 1.7 MPa, the cover must be pin-pricked.

Consult the chemical compatibility section on pages **Ab-26** to **Ab-34** for more detailed information.

Fitting Series



| Part Number | Hose I.D. | | | | Hose O.D. mm | Pressure Rating | | | | min. bend radius mm | weight kg |
|-------------|-----------|-------|------|------|-----------------|------------------------------|------|----------------------------|-------|------------------------|--------------|
| | DN | Inch | Size | mm | | max. working pressure MPa | psi | min. burst pressure MPa | psi | | |
| 492-4 | 6 | 1/4 | -4 | 6.4 | 11.5 | 28.0 | 4060 | 112.0 | 16240 | 75 | 0.18 |
| 492-5 | 8 | 5/16 | -5 | 7.9 | 13.6 | 25.0 | 3625 | 100.0 | 14500 | 85 | 0.21 |
| 492-6 | 10 | 3/8 | -6 | 9.5 | 15.5 | 22.5 | 3260 | 90.0 | 13050 | 90 | 0.25 |
| 492-8 | 12 | 1/2 | -8 | 12.7 | 18.9 | 19.0 | 2755 | 76.0 | 11020 | 130 | 0.33 |
| 492-10 | 16 | 5/8 | -10 | 15.9 | 22.2 | 15.0 | 2175 | 60.0 | 8700 | 150 | 0.41 |
| 492-12 | 19 | 3/4 | -12 | 19.1 | 26.0 | 15.0 | 2175 | 60.0 | 8700 | 180 | 0.56 |
| 492-16 | 25 | 1 | -16 | 25.4 | 33.3 | 11.0 | 1595 | 44.0 | 6380 | 230 | 0.75 |
| 492-20-WR | 31 | 1 1/4 | -20 | 31.8 | 40.0 | 7.5 | 1085 | 30.0 | 4350 | 335 | 0.93 |

Part Number without a suffix: the hose cover has a smooth appearance. Part Number with a suffix (WR): the hose cover has a wrapped appearance. The combination of high temperature and high pressure could reduce the hose life. Also available in reels up to size -16 under part number 492-xx-RL

Hose layline example



Medium Pressure
High abrasion resistance

Parkrimp No-Skive Hose
492TC

492TC

Elite No-Skive Compact Tough Cover
EN 857 1SC – ISO 11237 Type 1SC

Primary Applications

Demanding medium pressure hydraulic applications

Type Approvals

Details please find on pages **Ab-16** to **Ab-19**

Applicable Specifications

EN 857 1SC – ISO 11237 Type 1SC

Construction

Inner tube: Nitrile (NBR)
Reinforcement: One high-tensile steel wire braid
Cover: Highly abrasion resistance
MSHA approved

Temperature Range -40 °C up to +100 °C

Exception: Air max. +70 °C
Water max. +85 °C

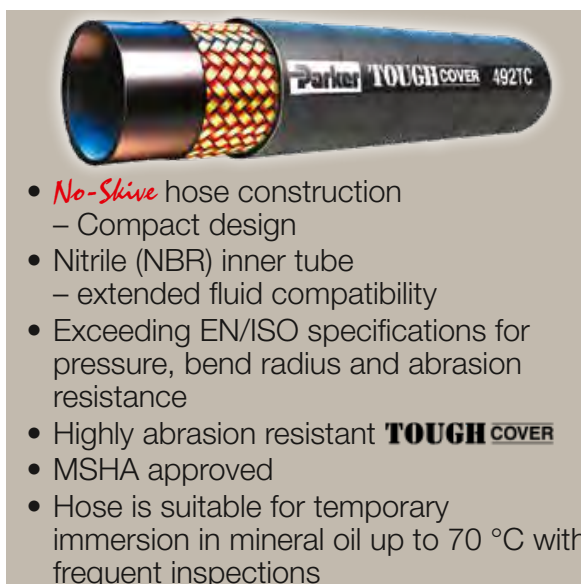

- *No-Skive* hose construction
– Compact design
- Nitrile (NBR) inner tube
– extended fluid compatibility
- Exceeding EN/ISO specifications for pressure, bend radius and abrasion resistance
- Highly abrasion resistant **TOUGH COVER**
- MSHA approved
- Hose is suitable for temporary immersion in mineral oil up to 70 °C with frequent inspections

Recommended Fluids

Hydraulic fluids on a mineral-oil basis, water-glycol and lubricating oils, air and water. For air and gas applications with a pressure exceeding 1.7 MPa, the cover must be pin-pricked.

Consult the chemical compatibility section on pages **Ab-26** to **Ab-34** for more detailed information.

Fitting Series



| Part Number | Hose I.D. | | | | Hose O.D. mm | Pressure Rating | | | | min. bend radius mm | weight kg |
|-------------|-----------|------|------|------|-----------------|------------------------------|------|----------------------------|-------|------------------------|--------------|
| | DN | Inch | Size | mm | | max. working pressure MPa | psi | min. burst pressure MPa | psi | | |
| 492TC-4 | 6 | 1/4 | -4 | 6.4 | 11.5 | 28.0 | 4060 | 112.0 | 16240 | 75 | 0.18 |
| 492TC-5 | 8 | 5/16 | -5 | 7.9 | 13.6 | 25.0 | 3625 | 100.0 | 14500 | 85 | 0.21 |
| 492TC-6 | 10 | 3/8 | -6 | 9.5 | 15.5 | 22.5 | 3260 | 90.0 | 13050 | 90 | 0.25 |
| 492TC-8 | 12 | 1/2 | -8 | 12.7 | 18.9 | 19.0 | 2755 | 76.0 | 11020 | 130 | 0.33 |
| 492TC-10 | 16 | 5/8 | -10 | 15.9 | 22.2 | 15.0 | 2175 | 60.0 | 8700 | 150 | 0.41 |
| 492TC-12 | 19 | 3/4 | -12 | 19.1 | 26.0 | 15.0 | 2175 | 60.0 | 8700 | 180 | 0.56 |
| 492TC-16 | 25 | 1 | -16 | 25.4 | 33.3 | 11.0 | 1595 | 44.0 | 6380 | 230 | 0.75 |

The combination of high temperature and high pressure could reduce the hose life.

Hose layline example

PARKER NO-SKIVE Tough Cover 492TC-8 WP 19,0 MPa (2755 PSI) MSHA | • • 12,7 mm [1/2] Made in Italy



Cab-29

Catalogue 4400/UK

Hose

Medium Pressure
Extreme abrasion resistance

Parkrimp No-Skive Hose
492ST

492ST

Elite *No-Skive* **Super Tough Compact**

EN 857 1SC – ISO 11237 Type 1SC

Primary Applications

Mobile market: Medium pressure hydraulic applications
with extremely high abrasion risks

Applicable Specifications

EN 857 1SC – ISO 11237 Type 1SC

Construction

Inner tube: Nitrile (NBR)
Reinforcement: One high-tensile steel wire braid
Cover: Synthetic rubber
with a special polyethylene coating

Temperature Range -40 °C up to +100 °C

Exception: Air max. +70 °C
Water max. +85 °C



- *No-Skive* hose construction
– Compact design
- Nitrile (NBR) inner tube
– extended fluid compatibility
- Extreme abrasion resistant
SUPER TOUGH cover
- Exceeding EN/ISO specifications for
pressure, bend radius and abrasion
resistance

Recommended Fluids

Hydraulic fluids on a mineral-oil basis, water-glycol and lubricating oils, air and water. For air and gas applications with a pressure exceeding 1.7 MPa, the cover must be pin-pricked.

Consult the chemical compatibility section on pages **Ab-26** to **Ab-34** for more detailed information.

Fitting Series



| Part Number | Hose I.D. | | | | Hose O.D. mm | Pressure Rating | | | | min. bend radius mm | weight kg |
|-------------|-----------|-------|------|------|-----------------|------------------------------|------|----------------------------|-------|------------------------|--------------|
| | DN | Inch | Size | mm | | max. working pressure MPa | psi | min. burst pressure MPa | psi | | |
| 492ST-4 | 6 | 1/4 | -4 | 6.4 | 12.0 | 28.0 | 4000 | 112.0 | 16240 | 75 | 0.18 |
| 492ST-5 | 8 | 5/16 | -5 | 7.9 | 13.6 | 25.0 | 3625 | 100.0 | 14500 | 85 | 0.21 |
| 492ST-6 | 10 | 3/8 | -6 | 9.5 | 15.5 | 22.5 | 3260 | 90.0 | 13050 | 90 | 0.25 |
| 492ST-8 | 12 | 1/2 | -8 | 12.7 | 18.9 | 19.0 | 2755 | 76.0 | 11020 | 130 | 0.33 |
| 492ST-10 | 16 | 5/8 | -10 | 15.9 | 22.3 | 15.0 | 2175 | 60.0 | 8700 | 150 | 0.41 |
| 492ST-12 | 19 | 3/4 | -12 | 19.1 | 26.0 | 15.0 | 2175 | 60.0 | 8700 | 180 | 0.56 |
| 492ST-16 | 25 | 1 | -16 | 25.4 | 33.6 | 11.0 | 1595 | 44.0 | 6380 | 230 | 0.75 |
| 492ST-20 | 31 | 1 1/4 | -20 | 31.8 | 40.0 | 7.5 | 1085 | 30.0 | 4350 | 335 | 0.93 |

The combination of high temperature and high pressure could reduce the hose life.

Hose layline example



Cab-30

Catalogue 4400/UK

493

No-Skive Compact

High pressure water cleaning applications



- One wire *No-Skive* construction
- For water up to +120 °C constant temperature

Primary Applications

High pressure water cleaners

Construction

Inner tube: Synthetic rubber
Reinforcement: One high-tensile steel wire braid
Cover: Synthetic rubber, black or blue

Temperature RangeWater max. +120 °C

Fitting Series



Hose

| Part Number | Hose I.D. | | | | Hose O.D. mm | Pressure Rating | | | | min. bend radius mm | weight kg |
|-------------|-----------|------|------|------|-----------------|------------------------------|------|----------------------------|------|------------------------|--------------|
| | DN | Inch | Size | mm | | max. working pressure MPa | psi | min. burst pressure MPa | psi | | |
| 493-4 | 6 | 1/4 | -4 | 6.4 | 13.4 | 20.0 | 2898 | 60.0 | 8695 | 60 | 0.18 |
| 493-4-BLU | 6 | 1/4 | -4 | 6.4 | 13.4 | 20.0 | 2898 | 60.0 | 8695 | 60 | 0.18 |
| 493-5 | 8 | 5/16 | -5 | 7.9 | 15.0 | 20.0 | 2898 | 60.0 | 8695 | 75 | 0.21 |
| 493-5-BLU | 8 | 5/16 | -5 | 7.9 | 15.0 | 20.0 | 2898 | 60.0 | 8695 | 75 | 0.21 |
| 493-6 | 10 | 3/8 | -6 | 9.5 | 17.4 | 20.0 | 2898 | 60.0 | 8695 | 90 | 0.25 |
| 493-6-BLU | 10 | 3/8 | -6 | 9.5 | 17.4 | 20.0 | 2898 | 60.0 | 8695 | 90 | 0.25 |
| 493-8 | 12 | 1/2 | -8 | 12.7 | 20.6 | 17.5 | 2536 | 52.5 | 7608 | 110 | 0.33 |
| 493-8-BLU | 12 | 1/2 | -8 | 12.7 | 20.6 | 17.5 | 2536 | 52.5 | 7608 | 110 | 0.33 |

WKS rubber hand grip for No-Skive high pressure water cleaning hoses can be found on page Eb-20.
The combination of high temperature and high pressure could reduce the hose life.
Also available on reels under part number 493-xx-RL

Hose layline example



Medium Pressure
Extremely flexible

Parkrimp No-Skive Hose
692

692

No-Skive Compact

Constant pressure, tight bend radius

Primary Applications

Material handling:

General small bending radii hydraulic applications, ideal for over the sheave or reel applications.

Applicable Specifications

Parker Specification

Construction

Inner tube: Nitrile (NBR)

Reinforcement: One or two high-tensile steel wire braids

Cover: Synthetic rubber

Temperature Range -40 °C up to +100 °C

Exception: Air max. +70 °C



- *No-Skive* hose construction – Compact design
- Nitrile (NBR) inner tube – extended fluid compatibility
- Constant working pressure of 21.0 MPa

Recommended Fluids

Hydraulic fluids on a mineral-oil basis, water-glycol and lubricating oils, air and water. For air and gas applications with a pressure exceeding 1.7 MPa, the cover must be pin-pricked.

Consult the chemical compatibility section on pages **Ab-26** to **Ab-34** for more detailed information.

Fitting Series



| Part Number | Hose I.D. | | | | Hose O.D. mm | Pressure Rating | | | | min. bend radius mm | weight kg |
|-------------|-----------|------|------|------|-----------------|------------------------------|------|----------------------------|-------|------------------------|--------------|
| | DN | Inch | Size | mm | | max. working pressure MPa | psi | min. burst pressure MPa | psi | | |
| 692-4 | 6 | 1/4 | -4 | 6.4 | 11.5 | 21.0 | 3045 | 84.0 | 12180 | 40 | 0.18 |
| 692-5 | 8 | 5/16 | -5 | 7.9 | 13.6 | 21.0 | 3045 | 84.0 | 12180 | 40 | 0.21 |
| 692-6 | 10 | 3/8 | -6 | 9.5 | 15.5 | 21.0 | 3045 | 84.0 | 12180 | 40 | 0.25 |
| 692-8 | 12 | 1/2 | -8 | 12.7 | 20.4 | 21.0 | 3045 | 84.0 | 12180 | 50 | 0.52 |
| 692-10 | 16 | 5/8 | -10 | 15.9 | 23.9 | 21.0 | 3045 | 84.0 | 12180 | 60 | 0.66 |

The combination of high temperature and high pressure could reduce the hose life.

Hose layline example



Cab-32

Catalogue 4400/UK

Medium Pressure
Extremely flexible

Parkrimp No-Skive Hose
692Twin

692Twin

No-Skive Compact

Twin constant pressure, tight bend radius



- **No-Skive** hose construction
 - Compact design
- Nitrile (NBR) inner tube
 - extended fluid compatibility
- Constant working pressure of 21.0 MPa

Primary Applications

Lifting and material handling equipment:
General small bending radii hydraulic applications, ideal over the sheave or reel applications

Applicable Specifications

Parker Specification

Construction

Inner tube: Nitrile (NBR)
Reinforcement: One or two high-tensile steel wire braids
Cover: Synthetic rubber

Temperature Range -40 °C up to +100 °C

Exception: Air max. +70 °C

Recommended Fluids

Hydraulic fluids on a mineral-oil basis, water-glycol and lubricating oils, air and water. For air and gas applications with a pressure exceeding 1.7 MPa, the cover must be pin-pricked.

Consult the chemical compatibility section on pages **Ab-26** to **Ab-34** for more detailed information.

Fitting Series



| Part Number | Hose I.D. | | | | Hose O.D. mm | Pressure Rating | | | | min. bend radius mm | weight kg |
|-------------|-----------|------|------|-----|-----------------|------------------------------|------|----------------------------|-------|------------------------|--------------|
| | DN | Inch | Size | mm | | max. working pressure MPa | psi | min. burst pressure MPa | psi | | |
| 692-4-4 | 6 | 1/4 | -4 | 6.4 | 25.8 | 21.0 | 3045 | 84.0 | 12180 | 40 | 0.34 |
| 692-5-5 | 8 | 5/16 | -5 | 7.9 | 27.4 | 21.0 | 3045 | 84.0 | 12180 | 40 | 0.40 |
| 692-6-6 | 10 | 3/8 | -6 | 9.5 | 31.2 | 21.0 | 3045 | 84.0 | 12180 | 40 | 0.48 |

The combination of high temperature and high pressure could reduce the hose life.

Hose layline example



Cab-33

Catalogue 4400/UK

Hose

Medium Pressure
Polyurethane Cover

Parkrimp No-Skive Hose
692PU

692PU

No-Skive Compact
Polyurethane Cover

Primary Applications

Material handling industry, where tight bend radii, flexibility, ozone, abrasion and shock resistance are needed and required. Ideal for over-the-sheave or reel applications.

Applicable Specifications

Parker Specification – constant working pressure

Construction

Inner Tube: Nitrile (NBR)
Reinforcement: One or two high-tensile steel wire braids
Cover: Premium-quality polyurethane

Temperature Range -45 °C up to +100 °C

Exception: Air max. +70 °C
Water max. +85 °C



- *No-Skive* hose construction – Compact design
- Constant working pressure
- High abrasion and shock resistance
- High flexibility even at cold conditions
- High ozone-, UV- and weathering resistance
- Extended fluid compatibility
- Tight bend radius

Recommended Fluids

Hydraulic fluids on a mineral-oil basis, water-glycol and lubricating oils, air and water. For air and gas applications with a pressure exceeding 1.7 MPa, the cover must be pin-pricked.

Consult the chemical compatibility section on pages **Ab-26** to **Ab-34** for more detailed information.

Fitting Series

Size -4 up to -6

Size -8 up to -10



| Part Number | Hose I.D. | | | | Hose O.D. mm | Pressure Rating | | | | min. bend radius mm | weight kg |
|-------------|-----------|------|------|------|-----------------|------------------------------|------|----------------------------|-------|------------------------|--------------|
| | DN | Inch | Size | mm | | max. working pressure MPa | psi | min. burst pressure MPa | psi | | |
| 692PU-4 | 6 | 1/4 | -4 | 6.4 | 11.5 | 21.0 | 3045 | 84.0 | 12180 | 40 | 0.18 |
| 692PU-5 | 8 | 5/16 | -5 | 7.9 | 13.6 | 21.0 | 3045 | 84.0 | 12180 | 40 | 0.21 |
| 692PU-6 | 10 | 3/8 | -6 | 9.5 | 15.5 | 21.0 | 3045 | 84.0 | 12180 | 40 | 0.25 |
| 692PU-8 | 12 | 1/2 | -8 | 12.7 | 20.4 | 21.0 | 3045 | 84.0 | 12180 | 50 | 0.52 |
| 692PU-10 | 16 | 5/8 | -10 | 15.9 | 23.9 | 21.0 | 3045 | 84.0 | 12180 | 60 | 0.66 |

The combination of high temperature and high pressure could reduce the hose life.

Hose layline example

PARKER 692PU-6 WP 21,0 MPa (3046 psi) | • • 10 mm (3/8 ")



Medium Pressure
Polyurethane Cover

Parkrimp No-Skive Hose
692PU Twin

692PU Twin

No-Skive Compact

Twin Hose with Polyurethane Cover

Primary Applications

Material handling industry, where tight bend radii, flexibility, ozone, abrasion and shock resistance are needed and required. Ideal for over-the-sheave or reel applications.

Applicable Specifications

Parker Specification – constant working pressure

Construction

Inner Tube: Nitrile (NBR)
Reinforcement: One or two high-tensile steel wire braids
Cover: Premium-quality polyurethane

Temperature Range -45 °C up to +100 °C

Exception: Air max. +70 °C

Water max. +85 °C

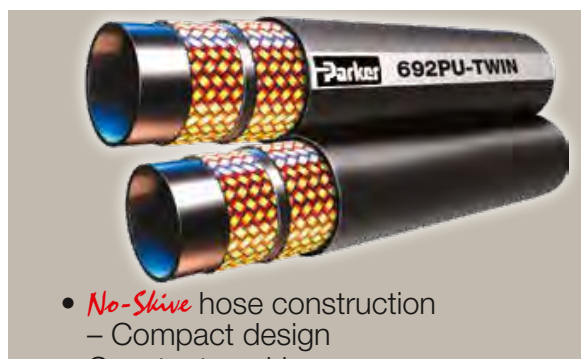

- *No-Skive* hose construction – Compact design
- Constant working pressure
- High abrasion and shock resistance
- High flexibility even at cold conditions
- High ozone-, UV- and weathering resistance
- Extended fluid compatibility
- Tight bend radius

Recommended Fluids

Hydraulic fluids on a mineral-oil basis, water-glycol and lubricating oils, air and water. For air and gas applications with a pressure exceeding 1.7 MPa, the cover must be pin-pricked.

Consult the chemical compatibility section on pages **Ab-26** to **Ab-34** for more detailed information.

Fitting Series

Size -4 up to -6

Size -8 up to -10



| Part Number | Hose I.D. | | | | Hose O.D. mm | Pressure Rating | | | | min. bend radius mm | weight kg |
|-------------|-----------|------|------|------|-----------------|------------------------------|------|----------------------------|-------|------------------------|--------------|
| | DN | Inch | Size | mm | | max. working pressure MPa | psi | min. burst pressure MPa | psi | | |
| 692PU-4-4 | 6 | 1/4 | -4 | 6.4 | 24.0 | 21.0 | 3045 | 84.0 | 12180 | 40 | 0.36 |
| 692PU-5-5 | 8 | 5/16 | -5 | 7.9 | 27.4 | 21.0 | 3045 | 84.0 | 12180 | 40 | 0.42 |
| 692PU-6-6 | 10 | 3/8 | -6 | 9.5 | 31.2 | 21.0 | 3045 | 84.0 | 12180 | 40 | 0.50 |
| 692PU-8-8 | 12 | 1/2 | -8 | 12.7 | 41.5 | 21.0 | 3045 | 84.0 | 12180 | 50 | 1.00 |
| 692PU-10-10 | 16 | 5/8 | -10 | 15.9 | 48.7 | 21.0 | 3045 | 84.0 | 12180 | 60 | 1.35 |

The combination of high temperature and high pressure could reduce the hose life.

Hose layline example



Cab-35

Catalogue 4400/UK

Medium Pressure
Extremely flexible

Parkrimp No-Skive Hose
692TC

692TC

No-Skive Compact Tough Cover
Constant pressure, tight bend radius

Primary Applications

Material handling:
General small bending radii hydraulic applications, ideal for over the sheave or reel applications.

Applicable Specifications

Parker Specification

Construction

Inner Tube: Nitrile (NBR)
Reinforcement: One or two high-tensile steel wire braids
Cover: Highly abrasion resistance
MSHA approved

Temperature Range -40 °C up to +100 °C
Exception: Air max. +70 °C

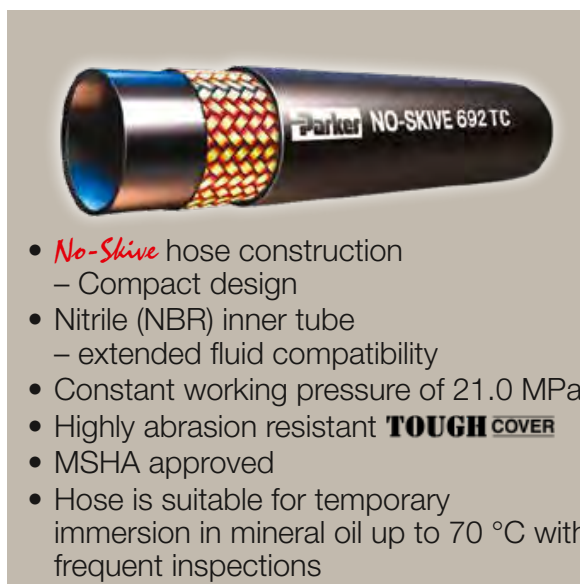

- *No-Skive* hose construction – Compact design
- Nitrile (NBR) inner tube – extended fluid compatibility
- Constant working pressure of 21.0 MPa
- Highly abrasion resistant **TOUGH COVER**
- MSHA approved
- Hose is suitable for temporary immersion in mineral oil up to 70 °C with frequent inspections

Recommended Fluids

Hydraulic fluids on a mineral-oil basis, water-glycol and lubricating oils, air and water. For air and gas applications with a pressure exceeding 1.7 MPa, the cover must be pin-pricked.

Consult the chemical compatibility section on pages **Ab-26** to **Ab-34** for more detailed information.

Fitting Series



| Part Number | Hose I.D. | | | | Hose O.D. mm | Pressure Rating | | | | min. bend radius mm | weight kg |
|-------------|-----------|------|------|------|-----------------|------------------------------|------|----------------------------|-------|------------------------|--------------|
| | DN | Inch | Size | mm | | max. working pressure MPa | psi | min. burst pressure MPa | psi | | |
| 692TC-4 | 6 | 1/4 | -4 | 6.4 | 11.5 | 21.0 | 3045 | 84.0 | 12180 | 40 | 0.18 |
| 692TC-5 | 8 | 5/16 | -5 | 7.9 | 13.6 | 21.0 | 3045 | 84.0 | 12180 | 40 | 0.21 |
| 692TC-6 | 10 | 3/8 | -6 | 9.5 | 15.5 | 21.0 | 3045 | 84.0 | 12180 | 40 | 0.25 |
| 692TC-8 | 12 | 1/2 | -8 | 12.7 | 20.4 | 21.0 | 3045 | 84.0 | 12180 | 50 | 0.52 |
| 692TC-10 | 16 | 5/8 | -10 | 15.9 | 23.9 | 21.0 | 3045 | 84.0 | 12180 | 60 | 0.66 |

The combination of high temperature and high pressure could reduce the hose life.

Hose layline example



Cab-36

Catalogue 4400/UK

811

No-Skive Suction and Return Line SAE 100R4



- *No-Skive* hose construction
- Helical wire to prevent collapse under vacuum
- Small bend radii

Primary Applications

All Markets: General applications

Type Approvals

Details please find on pages **Ab-16** to **Ab-19**

Construction

Inner tube: Synthetic rubber
Reinforcement: Two fibre spiral, one helical wire
Cover: Synthetic rubber ,
oil and weather resistant

Recommended Fluids

Hydraulic fluids on a mineral-oil basis, water-glycol and lubricating oils, air and water.
Consult the chemical compatibility section on pages **Ab-26** to **Ab-34** for more detailed information.

Temperature Range -40 °C up to +100 °C

Exception: Air max. +70 °C
Water max. +85 °C

Fitting Series

up to size - 32



For size -40 and -48

| Part Number | Hose I.D. | | | | Hose O.D. mm | Pressure Rating | | | | Vacuum* kPa | min. bend radius mm | weight kg |
|-------------|-----------|-------|------|------|-----------------|------------------------------|-----|----------------------------|------|----------------|------------------------|--------------|
| | DN | Inch | Size | mm | | max. working pressure MPa | psi | min. burst pressure MPa | psi | | | |
| 811-12 | 19 | 3/4 | -12 | 19.1 | 30.0 | 2.1 | 300 | 8.3 | 1200 | 85 | 65 | 0.63 |
| 811-16 | 25 | 1 | -16 | 25.4 | 38.0 | 1.7 | 250 | 6.9 | 1000 | 85 | 75 | 0.96 |
| 811-20 | 31 | 1 1/4 | -20 | 31.8 | 45.0 | 1.4 | 200 | 5.5 | 800 | 85 | 100 | 1.22 |
| 811-24 | 38 | 1 1/2 | -24 | 38.1 | 52.0 | 1.0 | 150 | 4.1 | 600 | 85 | 130 | 1.55 |
| 811-32 | 51 | 2 | -32 | 50.8 | 64.0 | 0.7 | 100 | 2.8 | 400 | 85 | 150 | 1.87 |
| 811-40 | 63 | 2 1/2 | -40 | 63.5 | 75.0 | 0.4 | 62 | 1.6 | 248 | 85 | 180 | 2.45 |
| 811-48 | 76 | 3 | -48 | 76.2 | 90.0 | 0.4 | 62 | 1.6 | 248 | 85 | 230 | 3.20 |

* The vacuum values listed in the table are vacuum pressure values in kPa. For an absolute value subtract the table value from 101 kPa.

** size -12 and size -16 = on Parkrimp 2 crimping press or adjustable crimpers only.
The combination of high temperature and high pressure could reduce the hose life.

Hose layline example

PARKER 811-12 SUCTION HOSE SAE 100R4-12 19 mm (3/4) 3Q81 ————— PARKER 811-12 SUC



811S

No-Skive Suction and Return Line

Exceeds SAE 100R4



- *No-Skive* hose construction
- Helical wire to prevent collapse under vacuum
- Small bend radii
- Isobaric 1.0 MPa for all sizes

Primary Applications

All Markets: General applications

Type Approvals

For size -64 and -80, details please find on pages **Ab-16** to **Ab-19**

Construction

Inner tube: Synthetic rubber
Reinforcement: Two fibre spiral, one helical wire
Cover: Synthetic rubber
oil and weather resistant

Recommended Fluids

Hydraulic fluids on a mineral-oil basis, water-glycol and lubricating oils, air and water.
Consult the chemical compatibility section on pages **Ab-26** to **Ab-34** for more detailed information.

Temperature Range -40 °C up to +100 °C

Exception: Air max. +70 °C
Water max. +85 °C

Fitting Series



| Part Number | Hose I.D. | | Hose O.D. mm ± 1.6 | Pressure Rating | | | | min. bend radius mm |
|-------------|-----------|-------|-----------------------|------------------------------|-----|----------------------------|-----|------------------------|
| | Size | mm | | max. working pressure MPa | psi | min. burst pressure MPa | psi | |
| 811S-40 | -40 | 63.5 | 75.0 | 1.0 | 145 | 4.0 | 580 | 240 |
| 811S-48 | -48 | 76.2 | 90.0 | 1.0 | 145 | 4.0 | 580 | 300 |
| 811S-56 | -56 | 88.9 | 106.0 | 1.0 | 145 | 4.0 | 580 | 360 |
| 811S-64 | -64 | 101.6 | 116.0 | 1.0 | 145 | 4.0 | 580 | 400 |
| 811S-80 | -80 | 127.0 | 142.0 | 1.0 | 145 | 4.0 | 580 | 500 |
| 811S-96 | -96 | 152.4 | 172.0 | 1.0 | 145 | 4.0 | 580 | 600 |

The combination of high temperature and high pressure could reduce the hose life.

Hose layline example

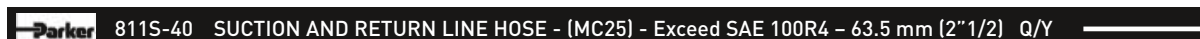

881

No-Skive Suction and Return Line SAE 100R4



- *No-Skive* hose construction
- Helical wire to prevent collapse under vacuum
- Up to +121 °C working temperature
- MSHA approved

Primary Applications

All Markets: For high temperature applications
For general applications

Type Approvals

Details please find on pages **Ab-16** to **Ab-19**

Construction

Inner tube: Synthetic rubber
Reinforcement: Two fibre braid, one helical wire
Cover: MSHA approved

Temperature Range -40 °C up to +121 °C

Exception: Air max. +70 °C
Water max. +85 °C

Recommended Fluids

Hydraulic fluids on a mineral-oil basis, water-glycol and lubricating oils, air and water.
Consult the chemical compatibility section on pages **Ab-26** to **Ab-34** for more detailed information.

Fitting Series

Series 43 for sizes -12, -16
Series 48 for sizes -20 up to -32
For size -40 fittings series on request



| Part Number | Hose I.D. | | | | Hose O.D. mm | Pressure Rating | | | | Vacuum* kPa | min. bend radius mm | weight kg |
|-------------|-----------|-------|------|------|-----------------|------------------------------|-----|----------------------------|------|----------------|------------------------|--------------|
| | DN | Inch | Size | mm | | max. working pressure MPa | psi | min. burst pressure MPa | psi | | | |
| 881-12 | 19 | 3/4 | -12 | 19.1 | 30.0 | 2.1 | 300 | 8.3 | 1200 | 95 | 130 | 0.74 |
| 881-16 | 25 | 1 | -16 | 25.4 | 38.0 | 1.7 | 250 | 6.9 | 1000 | 95 | 150 | 0.89 |
| 881-20 | 31 | 1 1/4 | -20 | 31.8 | 45.0 | 1.4 | 200 | 5.5 | 800 | 95 | 200 | 1.32 |
| 881-24 | 38 | 1 1/2 | -24 | 38.1 | 52.0 | 1.0 | 150 | 4.1 | 600 | 95 | 250 | 1.65 |
| 881-32 | 51 | 2 | -32 | 50.8 | 63.0 | 0.7 | 100 | 2.8 | 400 | 95 | 300 | 1.89 |
| 881-40 | 63 | 2 1/2 | -40 | 63.5 | 75.0 | 0.4 | 62 | 1.6 | 248 | 95 | 355 | 2.71 |

* The vacuum values listed in the table are vacuum pressure values in kPa. For an absolute value subtract the table value from 101kPa. The combination of high temperature and high pressure could reduce the hose life.





Hose layline example

PARKER 881-12 SUCTION HOSE MSHA XXXX SAE 100R4-12 19 mm (3/4) 3Q78 ————— PARKER



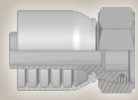
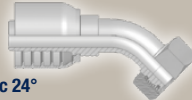

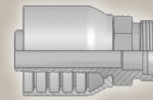
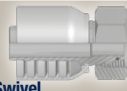

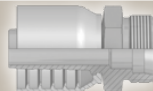
DIN – Metric

Page Cb-1 – Cb-4

| | | | |
|--------------------------------------------------------------------------------------------------------------------------------------------------------------------------------------------------------------------------------|---------------------------------------------------------------------------------------------------------------------------------------------------------------------------------------------------------------------------------------|--------------------------------------------------------------------------------------------------------------------------------------------------------------------------------------------------------------------------------------|----------------------------------------------------------------------------------------------------------------------------------------------------------------------------------------------------------------|
| <p>CA</p> <p>Cb-1</p>  <p>Female Metric 24° Light Series with O-Ring Swivel – Straight ISO 12151-2-SWS-L – DKOL</p> | <p>CE</p> <p>Cb-1</p>  <p>Female Metric 24° Light Series with O-Ring Swivel – 45° Elbow ISO 12151-2-SWE-L – DKOL 45°</p> | <p>CF</p> <p>Cb-2</p>  <p>Female Metric 24° Light Series with O-Ring Swivel – 90° Elbow ISO 12151-2-SWE-L – DKOL 90°</p> | <p>D0</p> <p>Cb-2</p>  <p>Male Metric 24° Light Series – Rigid Straight ISO 12151-2-S-L – CEL</p> |
| <p>C9</p> <p>Cb-3</p>  <p>Female Metric 24° – Swivel Heavy Series with O-Ring Straight ISO 12151-2-SWS-S – DKOS</p> | <p>OC</p> <p>Cb-3</p>  <p>Female Metric 24° – Swivel Heavy Series with O-Ring 45° Elbow ISO 12151-2 – SWE-S – DKOS 45°</p> | <p>1C</p> <p>Cb-4</p>  <p>Female Metric 24° – Swivel Heavy Series with O-Ring 90° Elbow ISO 12151-2-SWE-S – DKOS 90°</p> | <p>D2</p> <p>Cb-4</p>  <p>Male Metric 24° – Rigid Heavy Series – Straight ISO 12151-2-S-S – CES</p> |

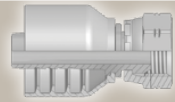
BSP

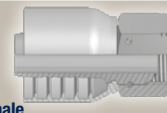
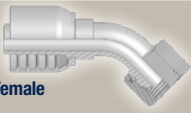
Page Cb-5 – Cb-8

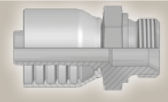
| | | | |
|--------------------------------------------------------------------------------------------------------------------------------------------------------------------------------------------------------------------------------|--------------------------------------------------------------------------------------------------------------------------------------------------------------------------------------------------------------------------------|--------------------------------------------------------------------------------------------------------------------------------------------------------------------------------------------------------------------|--------------------------------------------------------------------------------------------------------------------------------------------------------------------------------------------------------------|
| <p>92</p> <p>Cb-5</p>  <p>Female BSP Parallel Pipe Swivel – Straight (60° Cone) BS5200-A – DKR</p> | <p>B1</p> <p>Cb-5</p>  <p>Female BSP Parallel Pipe Swivel 45° Elbow (60° Cone) BS 5200-D – DKR 45°</p> | <p>B2</p> <p>Cb-6</p>  <p>Female BSP Parallel Pipe Swivel 90° Elbow (60° Cone) BS 5200-B – DKR 90°</p> | <p>EA</p> <p>Cb-6</p>  <p>BSP Swivel Female with O-Ring (60° Cone) BS 5200 – ISO 12151-6 – DKOR</p> |
| <p>EB</p> <p>Cb-7</p>  <p>BSP Swivel Female with O-Ring 45° Elbow (60° Cone) BS 5200 – ISO 12151-6 – DKOR 45°</p> | <p>EC</p> <p>Cb-7</p>  <p>BSP Swivel Female with O-Ring 90° Elbow (60° Cone) BS 5200 – ISO 12151-6 – DKOR 90°</p> | <p>D9</p> <p>Cb-8</p>  <p>Male BSP Parallel Pipe Rigid – Straight (60° Cone) BS5200 – AGR</p> | |

SAE

Page Cb-9 – Cb-10

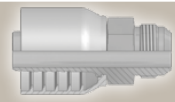
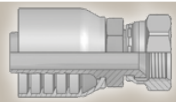
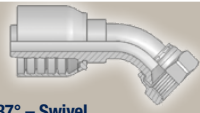
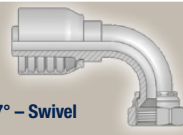
| | | | |
|-----------------------------------------------------------------------------------------------------------------------------------------------------------------------------------------|----------------------------------------------------------------------------------------------------------------------------------------------------------------------------------------------|----------------------------------------------------------------------------------------------------------------------------------------------------------------------------------------------------------|--------------------------------------------------------------------------------------------------------------------------------------------------------------------------------------------------------|
| <p>03</p> <p>Cb-9</p>  <p>Male JIC 37° – Rigid Straight ISO12151-5-S – AGJ</p> | <p>06</p> <p>Cb-9</p>  <p>Female JIC 37° – Swivel Straight ISO12151-5-SWS – DKJ</p> | <p>37</p> <p>Cb-10</p>  <p>Female JIC 37° – Swivel 45° Elbow ISO 12151-5-SWE 45° – DKJ 45°</p> | <p>39</p> <p>Cb-10</p>  <p>Female JIC 37° – Swivel 90° Elbow ISO 12151-5-SWES – DKJ 90°</p> |
|-----------------------------------------------------------------------------------------------------------------------------------------------------------------------------------------|----------------------------------------------------------------------------------------------------------------------------------------------------------------------------------------------|----------------------------------------------------------------------------------------------------------------------------------------------------------------------------------------------------------|--------------------------------------------------------------------------------------------------------------------------------------------------------------------------------------------------------|

Flange

Page Cb-11 – Cb-13

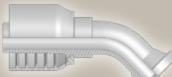
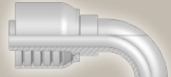
| | | | |
|---------------------------------------------------------------------------------------------------------------------------------------------------------------------------------------------------------------------|-------------------------------------------------------------------------------------------------------------------------------------------------------------------------------------------------------------------------|------------------------------------------------------------------------------------------------------------------------------------------------------------------------------------------------------------------------|----------------------------------------------------------------------------------------------------------------------------------------------------------------------------------------------------------------|
| <p>15 Cb-11</p>  <p>ISO 6162-1-Flange Straight ISO 12151-3-S-L – SFL (21.0 MPa/ 3000 psi)</p> | <p>17 Cb-11</p>  <p>ISO 6162-1-Flange 45° Elbow ISO 12151-3 – E45 – L – SFL 45° (21.0 MPa/ 3000 psi)</p> | <p>19 Cb-12</p>  <p>ISO 6162-1-Flange 90° Elbow ISO 12151-3 – E – L – SFL 90° (21.0 MPa/ 3000 psi)</p> | <p>6A Cb-12</p>  <p>ISO 6162-2-Flange Straight ISO 12151-3-S-S – SFS (42.0 MPa/ 6000 psi)</p> |
| <p>6N Cb-13</p>  <p>ISO 6162-2-Flange 90° Elbow ISO 12151-3 – E-S – SFS 90° (42.0 MPa/ 6000 psi)</p> | | | |

ORFS

Page Cb-14 – Cb-15

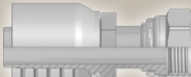
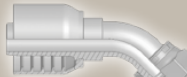
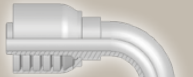
| | | | |
|---------------------------------------------------------------------------------------------------------------------------------------------------------------------------------------------------------------|-----------------------------------------------------------------------------------------------------------------------------------------------------------------------------------------------|------------------------------------------------------------------------------------------------------------------------------------------------------------------------------------------------------------------|-----------------------------------------------------------------------------------------------------------------------------------------------------------------------------------------------------------------------------|
| <p>JC Cb-14</p>  <p>Female ORFS Swivel – Straight Short ISO 12151-1 – SWSA SAE J516 – ORFS</p> | <p>JS Cb-14</p>  <p>ORFS Swivel Female (Long) ISO 12151-1-SWSB SAE J516 – ORFS</p> | <p>J7 Cb-15</p>  <p>Female ORFS – Swivel 45° Elbow ISO 12151-1 – SWE 45° SAE J516 – ORFS 45°</p> | <p>J9 Cb-15</p>  <p>Female ORFS – Swivel 90° Elbow – Short Drop ISO 12151-1 – SWES SAE J516 – ORFS 90°</p> |
|---------------------------------------------------------------------------------------------------------------------------------------------------------------------------------------------------------------|-----------------------------------------------------------------------------------------------------------------------------------------------------------------------------------------------|------------------------------------------------------------------------------------------------------------------------------------------------------------------------------------------------------------------|-----------------------------------------------------------------------------------------------------------------------------------------------------------------------------------------------------------------------------|

CA **Female Metric 24°
Light Series with O-Ring
Swivel – Straight**
ISO 12151-2-SWS-L – DKOL

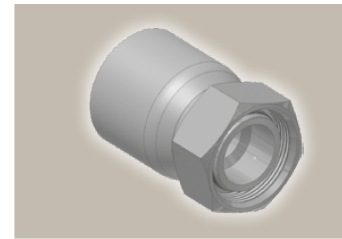
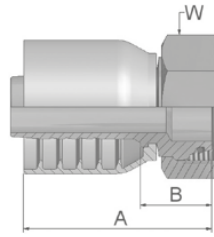

| Part Number | Hose I.D. | | | | Thread metric | Tube O.D. mm | A mm | B mm | W mm |
|-------------|-----------|------|------|------|------------------|--------------------|---------|---------|---------|
| | DN | Inch | Size | mm | | | | | |
| 1CA43-10-6 | 10 | 3/8 | -6 | 9.5 | M16x1.5 | 10 | 54 | 25 | 19 |
| 1CA43-12-6 | 10 | 3/8 | -6 | 9.5 | M18x1.5 | 12 | 49 | 20 | 22 |
| 1CA43-15-8 | 12 | 1/2 | -8 | 12.7 | M22x1.5 | 15 | 57 | 22 | 27 |
| 1CA43-18-10 | 16 | 5/8 | -10 | 15.9 | M26x1.5 | 18 | 61 | 22 | 32 |
| 1CA43-22-10 | 16 | 5/8 | -10 | 15.9 | M30x2 | 22 | 64 | 24 | 36 |
| 1CA43-18-12 | 19 | 3/4 | -12 | 19.1 | M26x1.5 | 18 | 65 | 26 | 32 |
| 1CA43-22-12 | 19 | 3/4 | -12 | 19.1 | M30x2 | 22 | 63 | 24 | 36 |
| 1CA43-28-16 | 25 | 1 | -16 | 25.4 | M36x2 | 28 | 78 | 33 | 41 |
| 1CA43-35-16 | 25 | 1 | -16 | 25.4 | M45x2 | 35 | 76 | 31 | 50 |

Hose fittings are delivered with ozone resistant Nitrile (NBR) O-ring as a standard version. Working temperature from -40 °C up to +105 °C.
Hose fittings with special O-rings (Viton or EPDM) available on request. O-ring dimensions and part-numbers see in section Eb.

CE **Female Metric 24°
Light Series with O-Ring
Swivel – 45° Elbow**
ISO 12151-2-SWE -L – DKOL 45°

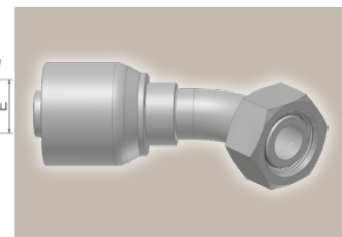
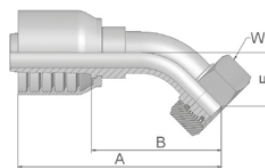

| Part Number | Hose I.D. | | | | Thread metric | Tube O.D. mm | A mm | B mm | E mm | W mm |
|-------------|-----------|------|------|------|------------------|--------------------|---------|---------|---------|---------|
| | DN | Inch | Size | mm | | | | | | |
| 1CE43-12-6 | 10 | 3/8 | -6 | 9.5 | M18x1.5 | 12 | 69 | 40 | 20 | 22 |
| 1CE43-15-8 | 12 | 1/2 | -8 | 12.7 | M22x1.5 | 15 | 82 | 48 | 23 | 27 |
| 1CE43-18-10 | 16 | 5/8 | -10 | 15.9 | M26x1.5 | 18 | 89 | 49 | 23 | 32 |
| 1CE43-22-12 | 19 | 3/4 | -12 | 19.1 | M30x2 | 22 | 98 | 58 | 26 | 36 |
| 1CE43-28-16 | 25 | 1 | -16 | 25.4 | M36x2 | 28 | 127 | 80 | 34 | 41 |

Hose fittings are delivered with ozone resistant Nitrile (NBR) O-ring as a standard version. Working temperature from -40 °C up to +105 °C.
Hose fittings with special O-rings (Viton or EPDM) available on request. O-ring dimensions and part-numbers see in section Eb.

43 Series

Approved **fitting series** for hose types, depending on size: Also available in stainless steel. Details can be found in CAT 4400.1/UK

| |
|-----------------------------------------------------------------------------|
| 43 304 387 387ST 387TC 421WC 426 487 487ST 487TC 722 722TC 722ST ... |
| 787 787TC 787ST 797 797TC 797ST 881 |



Medium Pressure
DIN – Metric

Parkrimp No-Skive Fittings
43 Series

CF **Female Metric 24°
Light Series with O-Ring
Swivel – 90° Elbow**
ISO 12151-2-SWE-L – DKOL 90°

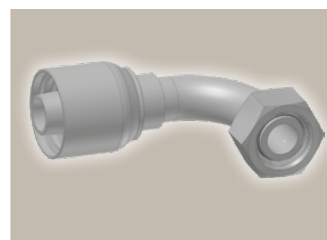
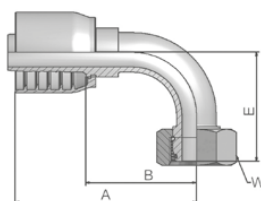

| Part Number | Hose I.D. | | | | Thread metric | Tube O.D. mm | A mm | B mm | E mm | W mm |
|-------------|-----------|------|------|------|------------------|--------------------|---------|---------|---------|---------|
| | DN | Inch | Size | mm | | | | | | |
| 1CF43-12-6 | 10 | 3/8 | -6 | 9.5 | M18x1.5 | 12 | 64 | 35 | 36 | 22 |
| 1CF43-15-8 | 12 | 1/2 | -8 | 12.7 | M22x1.5 | 15 | 71 | 37 | 44 | 27 |
| 1CF43-18-10 | 16 | 5/8 | -10 | 15.9 | M26x1.5 | 18 | 81 | 41 | 45 | 32 |
| 1CF43-22-12 | 19 | 3/4 | -12 | 19.1 | M30x2 | 22 | 89 | 49 | 55 | 36 |
| 1CF43-28-16 | 25 | 1 | -16 | 25.4 | M36x2 | 28 | 114 | 68 | 78 | 41 |

Hose fittings are delivered with ozone resistant Nitrile (NBR) O-ring as a standard version. Working temperature from -40 °C up to +105 °C.
Hose fittings with special O-rings (Viton or EPDM) available on request. O-ring dimensions and part-numbers see in section Eb.

D0 **Male Metric 24°
Light Series – Rigid
Straight**
ISO 12151-2-S-L – CEL

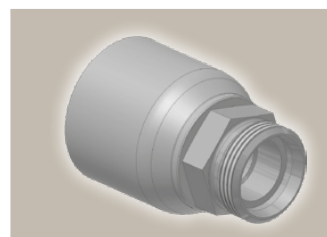
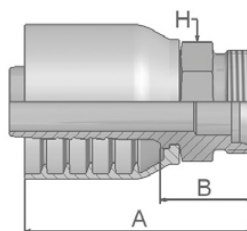

| Part Number | Hose I.D. | | | | Thread metric | Tube O.D. mm | A mm | B mm | H mm |
|-------------|-----------|------|------|------|------------------|--------------------|---------|---------|---------|
| | DN | Inch | Size | mm | | | | | |
| 1D043-15-8 | 12 | 1/2 | -8 | 12.7 | M22x1.5 | 15 | 60 | 26 | 22 |
| 1D043-28-16 | 25 | 1 | -16 | 25.4 | M36x2 | 28 | 79 | 32 | 36 |

Approved **fitting series** for hose types, depending on size: Also available in stainless steel. Details can be found in CAT 4400.1/UK

| | | | | | | | | | | | | | |
|-----------|-----|-------|-------|-------|-------|-------|-----|-------|-------|-----|-------|-------|-----|
| 43 | 304 | 387 | 387ST | 387TC | 421WC | 426 | 487 | 487ST | 487TC | 722 | 722TC | 722ST | ... |
| | 787 | 787TC | 787ST | 797 | 797TC | 797ST | 881 | | | | | | |



Cb-2

Catalogue 4400/UK

C9 Female Metric 24° – Swivel Heavy Series with O-Ring Straight

ISO 12151-2-SWS-S – DKOS

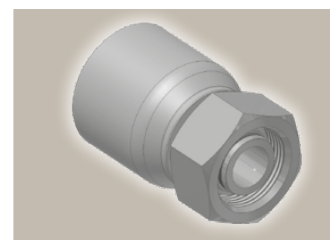
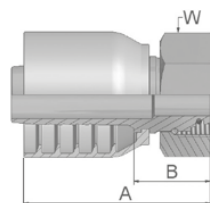

| Part Number | Hose I.D. | | | | Thread metric | Tube O.D. mm | A mm | B mm | W mm |
|-------------|-----------|------|------|------|------------------|--------------------|---------|---------|---------|
| | DN | Inch | Size | mm | | | | | |
| 1C943-10-6 | 10 | 3/8 | -6 | 9.5 | M18x1.5 | 10 | 50 | 21 | 22 |
| 1C943-12-6 | 10 | 3/8 | -6 | 9.5 | M20x1.5 | 12 | 52 | 22 | 24 |
| 1C943-14-6 | 10 | 3/8 | -6 | 9.5 | M22x1.5 | 14 | 50 | 21 | 27 |
| 1C943-12-8 | 12 | 1/2 | -8 | 12.7 | M20x1.5 | 12 | 60 | 25 | 24 |
| 1C943-16-8 | 12 | 1/2 | -8 | 12.7 | M24x1.5 | 16 | 59 | 24 | 30 |
| 1C943-16-10 | 16 | 5/8 | -10 | 15.9 | M24x1.5 | 16 | 66 | 27 | 30 |
| 1C943-20-10 | 16 | 5/8 | -10 | 15.9 | M30x2 | 20 | 66 | 27 | 36 |
| 1C943-20-12 | 19 | 3/4 | -12 | 19.1 | M30x2 | 20 | 66 | 27 | 36 |
| 1C943-25-12 | 19 | 3/4 | -12 | 19.1 | M36x2 | 25 | 68 | 28 | 46 |
| 1C943-25-16 | 25 | 1 | -16 | 25.4 | M36x2 | 25 | 78 | 33 | 46 |
| 1C943-30-16 | 25 | 1 | -16 | 25.4 | M42x2 | 30 | 80 | 33 | 50 |

Hose fittings are delivered with ozone resistant Nitrile (NBR) O-ring as a standard version. Working temperature from -40 °C up to +105 °C. Hose fittings with special O-rings (Viton or EPDM) available on request. O-ring dimensions and part-numbers see in section Eb.

OC Female Metric 24° – Swivel Heavy Series with O-Ring 45° Elbow

ISO 12151-2 – SWE -S – DKOS 45°

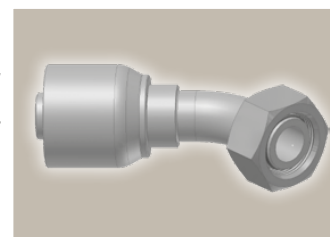
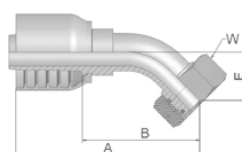

| Part Number | Hose I.D. | | | | Thread metric | Tube O.D. mm | A mm | B mm | E mm | W mm |
|-------------|-----------|------|------|------|------------------|--------------------|---------|---------|---------|---------|
| | DN | Inch | Size | mm | | | | | | |
| 10C43-12-6 | 10 | 3/8 | -6 | 9.5 | M20x1.5 | 12 | 69 | 40 | 20 | 24 |
| 10C43-14-6 | 10 | 3/8 | -6 | 9.5 | M22x1.5 | 14 | 76 | 46 | 20 | 27 |
| 10C43-16-8 | 12 | 1/2 | -8 | 12.7 | M24x1.5 | 16 | 82 | 48 | 24 | 30 |
| 10C43-20-10 | 16 | 5/8 | -10 | 15.9 | M30x2 | 20 | 91 | 51 | 25 | 36 |
| 10C43-20-12 | 19 | 3/4 | -12 | 19.1 | M30x2 | 20 | 99 | 60 | 28 | 36 |
| 10C43-25-12 | 19 | 3/4 | -12 | 19.1 | M36x2 | 25 | 100 | 61 | 29 | 46 |
| 10C43-25-16 | 25 | 1 | -16 | 25.4 | M36x2 | 30 | 123 | 76 | 33 | 46 |
| 10C43-30-16 | 25 | 1 | -16 | 25.4 | M42x2 | 30 | 126 | 79 | 36 | 50 |

Hose fittings are delivered with ozone resistant Nitrile (NBR) O-ring as a standard version. Working temperature from -40 °C up to +105 °C. Hose fittings with special O-rings (Viton or EPDM) available on request. O-ring dimensions and part-numbers see in section Eb.

Approved **fitting series** for hose types, depending on size: Also available in stainless steel. Details can be found in CAT 4400.1/UK

| | | | | | | | | | | | | |
|-----------|-----|-------|-------|-------|-------|-------|-----|-------|-------|-----|-------|-----------|
| 43 | 304 | 387 | 387ST | 387TC | 421WC | 426 | 487 | 487ST | 487TC | 722 | 722TC | 722ST ... |
| | 787 | 787TC | 787ST | 797 | 797TC | 797ST | 881 | | | | | |



1C Female Metric 24° – Swivel Heavy Series with O-Ring 90° Elbow

ISO 12151-2-SWE-S – DKOS 90°

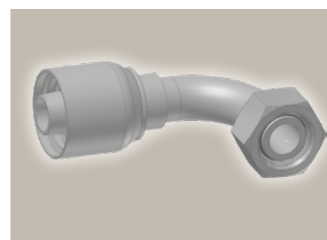
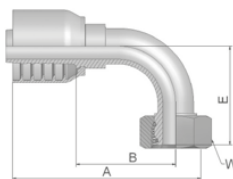

| Part Number | Hose I.D. | | | | Thread metric | Tube O.D. mm | A mm | B mm | E mm | W mm |
|-------------|-----------|------|------|------|---------------|--------------|------|------|------|------|
| | DN | Inch | Size | mm | | | | | | |
| 11C43-8-6 | 10 | 3/8 | -6 | 9.5 | M16x1.5 | 8 | 67 | 38 | 37 | 19 |
| 11C43-12-6 | 10 | 3/8 | -6 | 9.5 | M20x1.5 | 12 | 65 | 35 | 37 | 24 |
| 11C43-14-6 | 10 | 3/8 | -6 | 9.5 | M22x1.5 | 14 | 64 | 35 | 37 | 27 |
| 11C43-16-8 | 12 | 1/2 | -8 | 12.7 | M24x1.5 | 16 | 72 | 37 | 45 | 30 |
| 11C43-20-10 | 16 | 5/8 | -10 | 15.9 | M30x2 | 20 | 79 | 40 | 48 | 36 |
| 11C43-25-10 | 16 | 5/8 | -10 | 15.9 | M36x2 | 25 | 85 | 45 | 52 | 46 |
| 11C43-20-12 | 19 | 3/4 | -12 | 19.1 | M30x2 | 20 | 89 | 50 | 58 | 36 |
| 11C43-25-12 | 19 | 3/4 | -12 | 19.1 | M36x2 | 25 | 89 | 49 | 59 | 46 |
| 11C43-25-16 | 25 | 1 | -16 | 25.4 | M36x2 | 25 | 109 | 64 | 69 | 46 |
| 11C43-30-16 | 25 | 1 | -16 | 25.4 | M42x2 | 30 | 115 | 68 | 76 | 50 |

Hose fittings are delivered with ozone resistant Nitrile (NBR) O-ring as a standard version. Working temperature from -40 °C up to +105 °C. Hose fittings with special O-rings (Viton or EPDM) available on request. O-ring dimensions and part-numbers see in section Eb.

D2 Male Metric 24° – Rigid Heavy Series – Straight

ISO 12151-2-S-S – CES

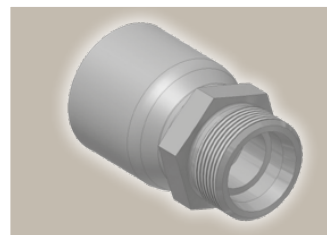
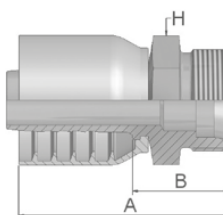

| Part Number | Hose I.D. | | | | Thread metric | Tube O.D. mm | A mm | B mm | H mm |
|-------------|-----------|------|------|------|---------------|--------------|------|------|------|
| | DN | Inch | Size | mm | | | | | |
| 1D243-12-6 | 10 | 3/8 | -6 | 9.5 | M20x1.5 | 12 | 55 | 26 | 22 |
| 1D243-14-6 | 10 | 3/8 | -6 | 9.5 | M22x1.5 | 14 | 55 | 25 | 22 |
| 1D243-16-8 | 12 | 1/2 | -8 | 12.7 | M24x1.5 | 16 | 62 | 28 | 24 |
| 1D243-20-10 | 16 | 5/8 | -10 | 15.9 | M30x2 | 20 | 72 | 33 | 30 |
| 1D243-20-12 | 19 | 3/4 | -12 | 19.1 | M30x2 | 20 | 72 | 33 | 30 |
| 1D243-25-12 | 19 | 3/4 | -12 | 19.1 | M36x2 | 25 | 74 | 35 | 36 |
| 1D243-30-16 | 25 | 1 | -16 | 25.4 | M42x2 | 30 | 85 | 40 | 46 |

Approved **fitting series** for hose types, depending on size: Also available in stainless steel. Details can be found in CAT 4400.1/UK

| | | | | | | | | | | | | | |
|----|-----|-------|-------|-------|-------|-------|-----|-------|-------|-----|-------|-------|-----|
| 43 | 304 | 387 | 387ST | 387TC | 421WC | 426 | 487 | 487ST | 487TC | 722 | 722TC | 722ST | ... |
| | 787 | 787TC | 787ST | 797 | 797TC | 797ST | 881 | | | | | | |

92 Female BSP Parallel Pipe Swivel – Straight (60° Cone)

BS5200-A – DKR

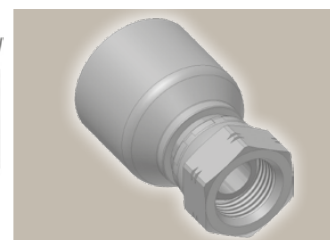
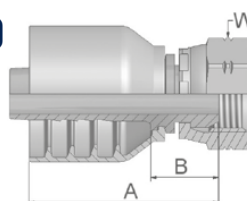

| Part Number | Hose I.D. | | | | Thread BSP | A mm | B mm | W mm |
|-------------|-----------|------|------|------|---------------|---------|---------|---------|
| | DN | Inch | Size | mm | | | | |
| 19243-6-6 | 10 | 3/8 | -6 | 9.5 | 3/8x19 | 49 | 20 | 22 |
| 19243-8-6 | 10 | 3/8 | -6 | 9.5 | 1/2x14 | 51 | 22 | 27 |
| 19243-8-8 | 12 | 1/2 | -8 | 12.7 | 1/2x14 | 57 | 22 | 27 |
| 19243-10-8 | 12 | 1/2 | -8 | 12.7 | 5/8x14 | 55 | 20 | 30 |
| 19243-10-10 | 16 | 5/8 | -10 | 15.9 | 5/8x14 | 57 | 21 | 30 |
| 19243-12-10 | 16 | 5/8 | -10 | 15.9 | 3/4x14 | 61 | 22 | 32 |
| 19243-12-12 | 19 | 3/4 | -12 | 19.1 | 3/4x14 | 61 | 22 | 32 |
| 19243-16-16 | 25 | 1 | -16 | 25.4 | 1x11 | 72 | 25 | 41 |

B1 Female BSP Parallel Pipe Swivel 45° Elbow (60° Cone)

BS 5200-D – DKR 45°

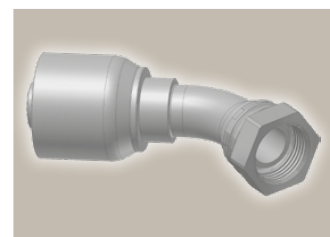
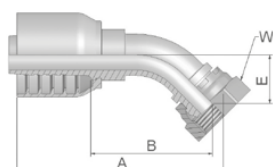

43 Series

| Part Number | Hose I.D. | | | | Thread BSP | A mm | B mm | E mm | W mm |
|-------------|-----------|------|------|------|---------------|---------|---------|---------|---------|
| | DN | Inch | Size | mm | | | | | |
| 1B143-6-6 | 10 | 3/8 | -6 | 9.5 | 3/8x19 | 67 | 37 | 17 | 22 |
| 1B143-8-8 | 12 | 1/2 | -8 | 12.7 | 1/2x14 | 79 | 45 | 20 | 27 |
| 1B143-10-10 | 16 | 5/8 | -10 | 15.9 | 5/8x14 | 89 | 50 | 23 | 30 |
| 1B143-12-12 | 19 | 3/4 | -12 | 19.1 | 3/4x14 | 96 | 57 | 25 | 32 |
| 1B143-16-16 | 25 | 1 | -16 | 25.4 | 1x11 | 121 | 77 | 33 | 41 |

Approved **fitting series** for hose types, depending on size: Also available in stainless steel. Details can be found in CAT 4400.1/UK

| |
|-----------------------------------------------------------------------------|
| 43 304 387 387ST 387TC 421WC 426 487 487ST 487TC 722 722TC 722ST ... |
| 787 787TC 787ST 797 797TC 797ST 881 |



B2 Female BSP Parallel Pipe Swivel 90° Elbow (60° Cone)

BS 5200-B – DKR 90°

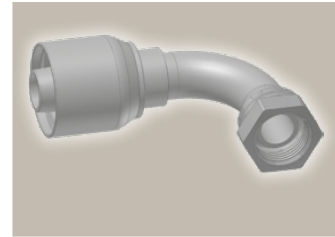
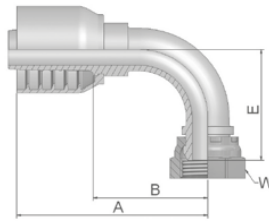

| Part Number | Hose I.D. | | | | Thread BSP | A mm | B mm | E mm | W mm |
|-------------|-----------|------|------|------|---------------|---------|---------|---------|---------|
| | DN | Inch | Size | mm | | | | | |
| 1B243-6-6 | 10 | 3/8 | -6 | 9.5 | 3/8x19 | 66 | 37 | 33 | 22 |
| 1B243-8-6 | 10 | 3/8 | -6 | 9.5 | 1/2x14 | 66 | 37 | 35 | 27 |
| 1B243-8-8 | 12 | 1/2 | -8 | 12.7 | 1/2x14 | 74 | 39 | 40 | 27 |
| 1B243-10-10 | 16 | 5/8 | -10 | 15.9 | 5/8x14 | 81 | 41 | 46 | 30 |
| 1B243-12-10 | 16 | 5/8 | -10 | 15.9 | 3/4x14 | 82 | 43 | 45 | 32 |
| 1B243-12-12 | 19 | 3/4 | -12 | 19.1 | 3/4x14 | 89 | 50 | 53 | 32 |
| 1B243-16-16 | 25 | 1 | -16 | 25.4 | 1x11 | 116 | 69 | 69 | 41 |

EA BSP Swivel Female with O-Ring (60° Cone)

BS 5200 – ISO 12151-6 – DKOR

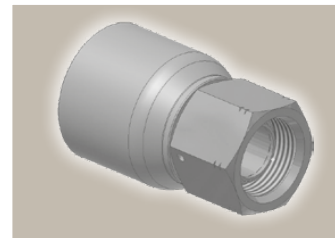
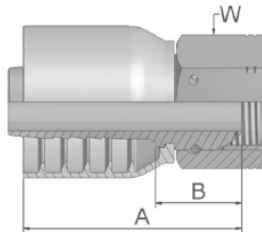

| Part Number | Hose I.D. | | | | Thread BSP | A mm | B mm | W mm |
|-------------|-----------|------|------|------|---------------|---------|---------|---------|
| | DN | Inch | Size | mm | | | | |
| 1EA43-8-8 | 12 | 1/2 | -8 | 12.7 | 1/2x14 | 56 | 21 | 27 |
| 1EA43-10-10 | 16 | 5/8 | -10 | 15.9 | 5/8x14 | 61 | 21.5 | 30 |
| 1EA43-12-12 | 19 | 3/4 | -12 | 19.1 | 3/4x14 | 63 | 23 | 32 |
| 1EA43-16-16 | 25 | 1 | -16 | 25.4 | 1x11 | 77 | 31 | 41 |

Hose fittings are delivered with ozone resistant Nitrile (NBR) O-ring as a standard version. Working temperature from -40 °C up to +105 °C. Hose fittings with special O-rings (Viton or EPDM) available on request. O-ring dimensions and part-numbers see in section Eb.

Approved **fitting series** for hose types, depending on size: Also available in stainless steel. Details can be found in CAT 4400.1/UK

| | | | | | | | | | | | | | |
|----|-----|-------|-------|-------|-------|-------|-----|-------|-------|-----|-------|-------|-----|
| 43 | 304 | 387 | 387ST | 387TC | 421WC | 426 | 487 | 487ST | 487TC | 722 | 722TC | 722ST | ... |
| | 787 | 787TC | 787ST | 797 | 797TC | 797ST | 881 | | | | | | |

EB BSP Swivel Female with O-Ring 45° Elbow (60° Cone)

BS 5200 – ISO 12151-6 – DKOR 45°

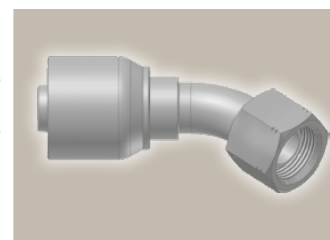
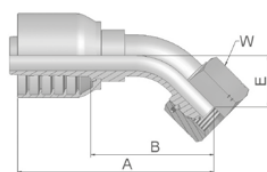

| Part Number | Hose I.D. | | | | Thread BSP | A mm | B mm | E mm | W mm |
|-------------|-----------|------|------|------|---------------|---------|---------|---------|---------|
| | DN | Inch | Size | mm | | | | | |
| 1EB43-4-4 | 6 | 1/4 | -4 | 6.4 | 1/4x19 | 57 | 34 | 14 | 19 |
| 1EB43-6-6 | 10 | 3/8 | -6 | 9.5 | 3/8x19 | 73 | 44 | 18 | 22 |
| 1EB43-8-8 | 12 | 1/2 | -8 | 12.7 | 1/2x14 | 79 | 44 | 20 | 27 |
| 1EB43-10-10 | 16 | 5/8 | -10 | 15.9 | 5/8 | 85 | 49 | 22 | 30 |

Hose fittings are delivered with ozone resistant Nitrile (NBR) O-ring as a standard version. Working temperature from -40 °C up to +105 °C.
Hose fittings with special O-rings (Viton or EPDM) available on request. O-ring dimensions and part-numbers see in section Eb.

EC BSP Swivel Female with O-Ring 90° Elbow (60° Cone)

BS 5200 – ISO 12151-6 – DKOR 90°

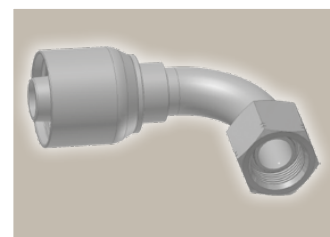
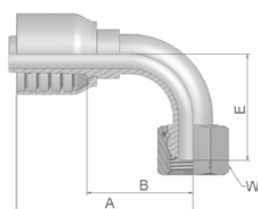

| Part Number | Hose I.D. | | | | Thread BSP | A mm | B mm | E mm | W mm |
|-------------|-----------|------|------|------|---------------|---------|---------|---------|---------|
| | DN | Inch | Size | mm | | | | | |
| 1EC43-4-4 | 6 | 1/4 | -4 | 6.4 | 1/4x19 | 50 | 27 | 24 | 19 |
| 1EC43-6-4 | 6 | 1/4 | -4 | 6.4 | 3/8x19 | 51 | 28 | 27 | 22 |
| 1EC43-6-6 | 10 | 3/8 | -6 | 9.5 | 3/8x19 | 64 | 35 | 34 | 22 |
| 1EC43-8-8 | 12 | 1/2 | -8 | 12.7 | 1/2x14 | 71 | 36 | 40 | 27 |
| 1EC43-10-10 | 16 | 5/8 | -10 | 15.9 | 5/8 | 80 | 43 | 44 | 30 |
| 1EC43-12-12 | 19 | 3/4 | -12 | 19.1 | 3/4x14 | 89 | 49 | 55 | 32 |
| 1EC43-16-16 | 25 | 1 | -16 | 25.4 | 1x11 | 115 | 68 | 71 | 41 |

Hose fittings are delivered with ozone resistant Nitrile (NBR) O-ring as a standard version. Working temperature from -40 °C up to +105 °C.
Hose fittings with special O-rings (Viton or EPDM) available on request. O-ring dimensions and part-numbers see in section Eb.

43 Series

Approved **fitting series** for hose types, depending on size: Also available in stainless steel. Details can be found in CAT 4400.1/UK

| | | | | | | | | | | | | | |
|-----------|-----|-------|-------|-------|-------|-------|-----|-------|-------|-----|-------|-------|-----|
| 43 | 304 | 387 | 387ST | 387TC | 421WC | 426 | 487 | 487ST | 487TC | 722 | 722TC | 722ST | ... |
| | 787 | 787TC | 787ST | 797 | 797TC | 797ST | 881 | | | | | | |



D9 Male BSP Parallel Pipe Rigid – Straight (60° Cone)

BS5200 – AGR

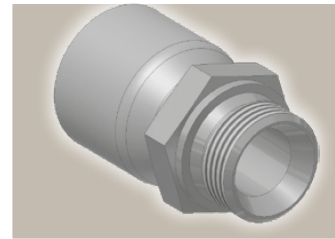
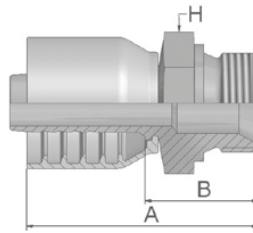

| Part Number | Hose I.D. | | | | Thread BSP | A mm | B mm | H mm |
|-------------|---------------|------|------|------|-------------------|---------|---------|-------------|
| | DN | Inch | Size | mm | | | | |
| 1D943-2-4 | 6 | 1/4 | -4 | 6.4 | 1/8x28 | 46 | 22 | 14 |
| 1D943-4-4 | 6 | 1/4 | -4 | 6.4 | 1/4x19 | 49 | 27 | 19 |
| 1D943-6-6 | 10 | 3/8 | -6 | 9.5 | 3/8x19 | 57 | 28 | 22 |
| 1D943-8-6 | 10 | 3/8 | -6 | 9.5 | 1/2x14 | 60 | 31 | 27 |
| 1D943-8-8 | 12 | 1/2 | -8 | 12.7 | 1/2x14 | 64 | 30 | 27 |
| 1D943-10-10 | 16 | 5/8 | -10 | 15.9 | 5/8x14 | 75 | 36 | 30 |
| 1D943-12-10 | 16 | 5/8 | -10 | 15.9 | 3/4x14 | 72 | 35 | 32 |
| 1D943-12-12 | 19 | 3/4 | -12 | 19.1 | 3/4x14 | 72 | 33 | 32 |
| 1D943-16-12 | 19 | 3/4 | -12 | 19.1 | 1x11 | 77 | 38 | 41 |
| 1D943-16-16 | 25 | 1 | -16 | 25.4 | 1x11 | 85 | 40 | 41 |

Approved **fitting series** for hose types, depending on size: Also available in stainless steel. Details can be found in CAT 4400.1/UK

| |
|-------------------------------------------------------------------------------------------|
| 304 387 387ST 387TC 421WC 426 487 487ST 487TC 722 722TC 722ST ... |
| 787 787TC 787ST 797 797TC 797ST 881 |



03 Male JIC 37° – Rigid Straight

ISO12151-5-S – AGJ

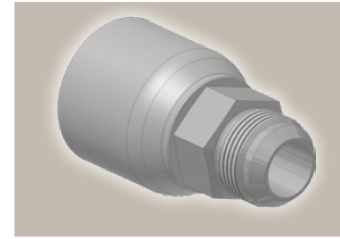
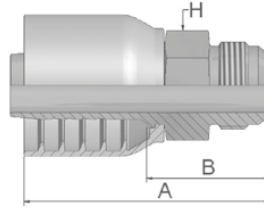

| Part Number | Hose I.D. | | | | Thread UNF | A mm | B mm | H | |
|-------------|-----------|------|------|-----|---------------|---------|---------|-----|----|
| | DN | Inch | Size | mm | | | | mm | mm |
| 10343-6-6 | 10 | 3/8 | -6 | 9.5 | 9/16x18 | 57 | 31 | 3/4 | |
| 10343-8-6 | 10 | 3/8 | -6 | 9.5 | 3/4x16 | 58 | 32 | 7/8 | |

06 Female JIC 37° – Swivel Straight

ISO12151-5-SWS – DKJ

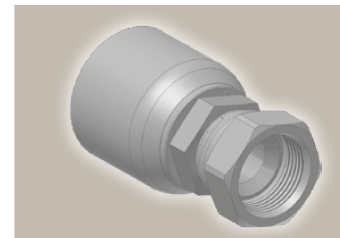
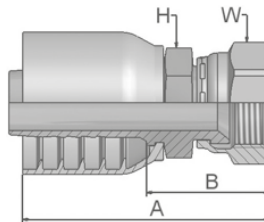

| Part Number | Hose I.D. | | | | Thread UNF | A mm | B mm | H | | W | |
|--------------|-----------|------|------|------|---------------|---------|---------|--------|-------|----|------|
| | DN | Inch | Size | mm | | | | mm | Inch | mm | Inch |
| 10643-6-6 | 10 | 3/8 | -6 | 9.5 | 9/16x18 | 58 | 32 | 11/16 | 11/16 | | |
| 10643-8-6 | 10 | 3/8 | -6 | 9.5 | 3/4x16 | 63 | 37 | 11/16 | 7/8 | | |
| 10643-8-8* | 12 | 1/2 | -8 | 12.7 | 3/4x16 | 66 | 34 | 13/16 | 7/8 | | |
| 10643-10-8 | 12 | 1/2 | -8 | 12.7 | 7/8x14 | 72 | 40 | 7/8 | 1 | | |
| 10643-10-10* | 16 | 5/8 | -10 | 15.9 | 7/8x14 | 73 | 38 | 15/16 | 1 | | |
| 10643-12-10 | 16 | 5/8 | -10 | 15.9 | 1 1/16x12 | 79 | 42 | 1 1/16 | 1 1/4 | | |
| 10643-12-12 | 19 | 3/4 | -12 | 19.1 | 1 1/16x12 | 81 | 44 | 1 1/16 | 1 1/4 | | |
| 10643-14-12 | 19 | 3/4 | -12 | 19.1 | 1 3/16x12 | 81 | 44 | 1 1/4 | 1 3/8 | | |
| 10643-12-16 | 25 | 1 | -16 | 25.4 | 1 1/16x12 | 84 | 42 | 1 3/8 | 1 1/4 | | |
| 10643-16-16 | 25 | 1 | -16 | 25.4 | 1 5/16x12 | 92 | 51 | 1 3/8 | 1 1/2 | | |

* These fittings contain a dual seat that accepts both JIC (37°) and SAE (45°) male configurations.

Approved **fitting series** for hose types, depending on size: Also available in stainless steel. Details can be found in CAT 4400.1/UK

| | | | | | | | | | | | | | |
|-----------|-----|-------|-------|-------|-------|-------|-----|-------|-------|-----|-------|-------|-----|
| 43 | 304 | 387 | 387ST | 387TC | 421WC | 426 | 487 | 487ST | 487TC | 722 | 722TC | 722ST | ... |
| | 787 | 787TC | 787ST | 797 | 797TC | 797ST | 881 | | | | | | |



37 Female JIC 37° – Swivel 45° Elbow

ISO 12151-5-SWE 45° – DKJ 45°

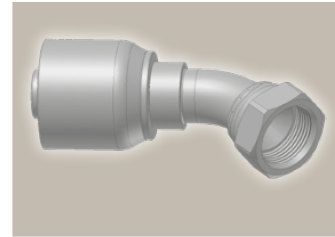
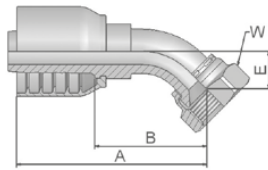

| Part Number | Hose I.D. | | | | Thread UNF | A mm | B mm | E mm | W mm |
|-------------|-----------|------|------|------|---------------|---------|---------|---------|---------|
| | DN | Inch | Size | mm | | | | | |
| 13743-6-6 | 10 | 3/8 | -6 | 9.5 | 9/16x18 | 61 | 35 | 10 | 11/16 |
| 13743-8-8 | 12 | 1/2 | -8 | 12.7 | 3/4x16 | 72 | 40 | 14 | 7/8 |
| 13743-12-12 | 19 | 3/4 | -12 | 19.1 | 1 1/16x12 | 92 | 56 | 20 | 1 1/4 |
| 13743-16-12 | 19 | 3/4 | -12 | 19.1 | 1 5/16x12 | 95 | 56 | 24 | 3/8 |
| 13743-16-16 | 25 | 1 | -16 | 25.4 | 1 5/16x12 | 110 | 69 | 24 | 1 1/2 |

* These fittings contain a dual seat that accepts both JIC (37°) and SAE (45°) male configurations.

39 Female JIC 37° – Swivel 90° Elbow

ISO 12151-5-SWES – DKJ 90°

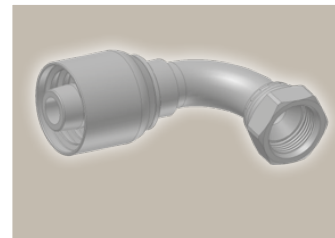
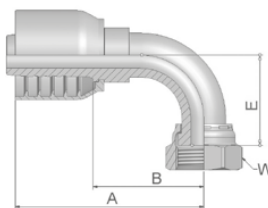

| Part Number | Hose I.D. | | | | Thread UNF | A mm | B mm | E mm | W mm Inch |
|--------------|-----------|------|------|------|---------------|---------|---------|---------|--------------|
| | DN | Inch | Size | mm | | | | | |
| 13943-6-6 | 10 | 3/8 | -6 | 9.5 | 9/16x18 | 56 | 30 | 23 | 11/16 |
| 13943-10-8 | 12 | 1/2 | -8 | 12.7 | 7/8x14 | 70 | 38 | 32 | 1 |
| 13943-10-10* | 16 | 5/8 | -10 | 15.9 | 7/8x14 | 80 | 40 | 37 | 1 |
| 13943-12-12 | 19 | 3/4 | -12 | 19.1 | 1 1/16x12 | 89 | 52 | 48 | 1 1/4 |
| 13943-16-16 | 25 | 1 | -16 | 25.4 | 1 5/16x12 | 109 | 68 | 56 | 1 1/2 |

* These fittings contain a dual seat that accepts both JIC (37°) and SAE (45°) male configurations.

Approved **fitting series** for hose types, depending on size: Also available in stainless steel. Details can be found in CAT 4400.1/UK

| | | | | | | | | | | | | | |
|-----------|-----|-------|-------|-------|-------|-------|-----|-------|-------|-----|-------|-------|-----|
| 43 | 304 | 387 | 387ST | 387TC | 421WC | 426 | 487 | 487ST | 487TC | 722 | 722TC | 722ST | ... |
| | 787 | 787TC | 787ST | 797 | 797TC | 797ST | 881 | | | | | | |



15 ISO 6162-1-Flange Straight

ISO 12151-3-S-L – SFL
(21.0 MPa/ 3000 psi)

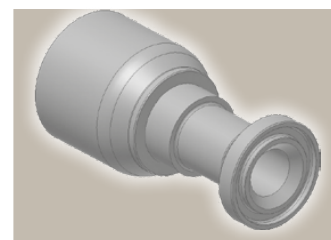
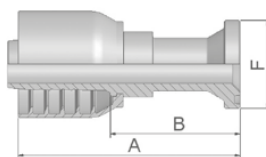

| Part Number | Hose I.D. | | | | Flange Inch | A mm | B mm | F mm |
|-------------|-----------|------|------|------|----------------|---------|---------|---------|
| | DN | Inch | Size | mm | | | | |
| 11543-8-8 | 12 | 1/2 | -8 | 12.7 | 1/2 | 89 | 54 | 30 |
| 11543-12-10 | 16 | 5/8 | -10 | 15.9 | 3/4 | 69 | 30 | 38 |
| 11543-12-12 | 19 | 3/4 | -12 | 19.1 | 3/4 | 98 | 59 | 38 |
| 11543-16-12 | 19 | 3/4 | -12 | 19.1 | 1 | 70 | 31 | 45 |
| 11543-16-16 | 25 | 1 | -16 | 25.4 | 1 | 108 | 63 | 45 |
| 11543-20-16 | 25 | 1 | -16 | 25.4 | 1 1/4 | 82 | 36 | 51 |

To select corresponding half-flange and O-ring see section Eb.

17 ISO 6162-1 Flange 45° Elbow

ISO 12151-3 – E45 – L – SFL 45°
(21.0 MPa/ 3000 psi)

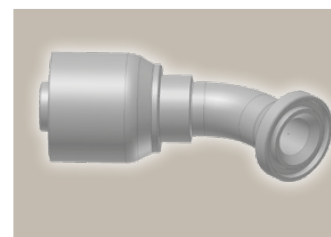
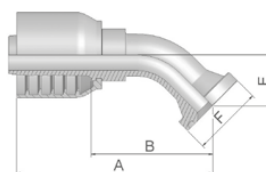

| Part Number | Hose I.D. | | | | Flange Inch | A mm | B mm | E mm | F mm |
|-------------|-----------|------|------|------|----------------|---------|---------|---------|---------|
| | DN | Inch | Size | mm | | | | | |
| 11743-8-8 | 12 | 1/2 | -8 | 12.7 | 1/2 | 79 | 44 | 20 | 30 |
| 11743-12-10 | 16 | 5/8 | -10 | 15.9 | 3/4 | 96 | 57 | 26 | 38 |
| 11743-12-12 | 19 | 3/4 | -12 | 19.1 | 3/4 | 98 | 58 | 26 | 38 |
| 11743-16-16 | 25 | 1 | -16 | 25.4 | 1 | 119 | 73 | 27 | 45 |
| 11743-20-16 | 25 | 1 | -16 | 25.4 | 1 1/4 | 121 | 76 | 32 | 51 |

To select corresponding half-flange and O-ring see section Eb.

43 Series

Approved **fitting series** for hose types, depending on size: Also available in stainless steel. Details can be found in CAT 4400.1/UK

| | | | | | | | | | | | | |
|-----------|-----|-------|-------|-------|-------|-------|-----|-------|-------|-----|-------|-----------|
| 43 | 304 | 387 | 387ST | 387TC | 421WC | 426 | 487 | 487ST | 487TC | 722 | 722TC | 722ST ... |
| | 787 | 787TC | 787ST | 797 | 797TC | 797ST | 881 | | | | | |

19

ISO 6162-1-Flange 90° Elbow

ISO 12151-3 – E– L – SFL 90°
(21.0 MPa/ 3000 psi)

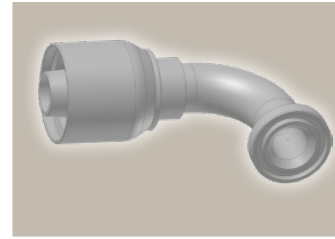
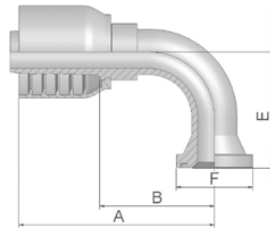

| Part Number | Hose I.D. | | | | Flange Inch | A mm | B mm | E mm | F mm |
|-------------|-----------|------|------|------|----------------|---------|---------|---------|---------|
| | DN | Inch | Size | mm | | | | | |
| 11943-8-8 | 12 | 1/2 | -8 | 12.7 | 1/2 | 75 | 40 | 41 | 30 |
| 11943-12-12 | 19 | 3/4 | -12 | 19.1 | 3/4 | 89 | 50 | 58 | 38 |
| 11943-16-12 | 19 | 3/4 | -12 | 19.1 | 1 | 90 | 50 | 58 | 45 |

To select corresponding half-flange and O-ring see section Eb.

6A

ISO 6162-2-Flange Straight

ISO 12151-3-S-S – SFS
(42.0 MPa/ 6000 psi)

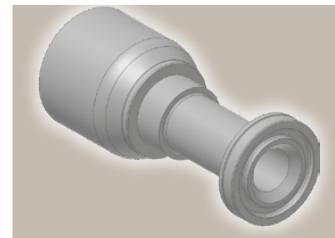
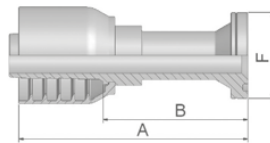

| Part Number | Hose I.D. | | | | Flange Inch | A mm | B mm | F mm |
|-------------|-----------|------|------|------|----------------|---------|---------|---------|
| | DN | Inch | Size | mm | | | | |
| 16A43-12-12 | 19 | 3/4 | -12 | 19.1 | 3/4 | 105 | 66 | 41 |
| 16A43-16-16 | 25 | 1 | -16 | 25.4 | 1 | 127 | 82 | 48 |

To select corresponding half-flange and O-ring see section Eb.

Approved **fitting series** for hose types, depending on size: Also available in stainless steel. Details can be found in CAT 4400.1/UK

| | | | | | | | | | | | | | |
|-----------|-----|-------|-------|-------|-------|-------|-----|-------|-------|-----|-------|-------|-----|
| 43 | 304 | 387 | 387ST | 387TC | 421WC | 426 | 487 | 487ST | 487TC | 722 | 722TC | 722ST | ... |
| | 787 | 787TC | 787ST | 797 | 797TC | 797ST | 881 | | | | | | |



Medium Pressure
Flange

Parkrimp No-Skive Fittings
43 Series

6N ISO 6162-2-Flange 90° Elbow

ISO 12151-3 – E-S – SFS 90°
(42.0 MPa/ 6000 psi)

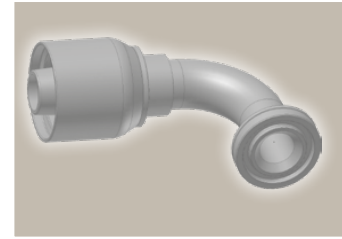
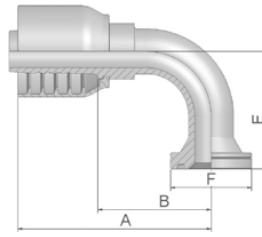

| Part Number | Hose I.D. | | | | Flange Inch | A mm | B mm | E mm | F mm |
|-------------|-----------|------|------|------|----------------|---------|---------|---------|---------|
| | DN | Inch | Size | mm | | | | | |
| 16N43-12-12 | 19 | 3/4 | -12 | 19.1 | 3/4 | 98 | 58 | 54 | 41 |
| 16N43-16-16 | 25 | 1 | -16 | 25.4 | 1 | 111 | 64 | 70 | 48 |

To select corresponding half-flange and O-ring see section Eb.

43 Series

Approved **fitting series** for hose types, depending on size: Also available in stainless steel. Details can be found in CAT 4400.1/UK

| | | | | | | | | | | | | |
|-----------|-----|-------|-------|-------|-------|-------|-----|-------|-------|-----|-------|-----------|
| 43 | 304 | 387 | 387ST | 387TC | 421WC | 426 | 487 | 487ST | 487TC | 722 | 722TC | 722ST ... |
| | 787 | 787TC | 787ST | 797 | 797TC | 797ST | 881 | | | | | |



Cb-13

Catalogue 4400/UK

Medium Pressure
ORFS

Parkrimp No-Skive Fittings
43 Series

JC Female ORFS Swivel – Straight Short

ISO 12151-1 – SWSA
SAE J516 – ORFS

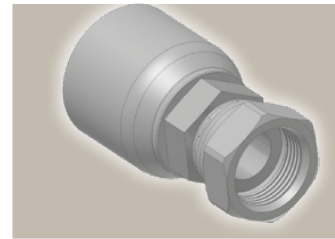
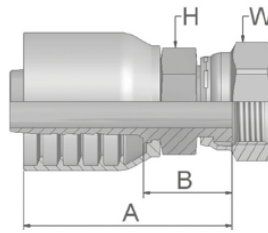

| Part Number | Hose I.D. | | | | Thread UNF | A mm | B mm | H mm | W mm |
|-------------|-----------|------|------|------|---------------|---------|---------|---------|---------|
| | DN | Inch | Size | mm | | | | | |
| 1JC43-6-6 | 10 | 3/8 | -6 | 9.5 | 11/16x16 | 49 | 23 | 11/16 | 13/16 |
| 1JC43-8-8 | 12 | 1/2 | -8 | 12.7 | 13/16x16 | 56 | 24 | 13/16 | 15/16 |
| 1JC43-10-8 | 12 | 1/2 | -8 | 12.7 | 1x14 | 58 | 26 | 15/16 | 1-1/8 |
| 1JC43-10-10 | 16 | 5/8 | -10 | 15.9 | 1x14 | 63 | 27 | 15/16 | 1-1/8 |
| 1JC43-12-12 | 19 | 3/4 | -12 | 19.1 | 1 3/16x12 | 68 | 31 | 1 1/8 | 1 3/8 |
| 1JC43-16-12 | 19 | 3/4 | -12 | 19.1 | 1 7/16x12 | 72 | 35 | 1 3/8 | 1 5/8 |
| 1JC43-16-16 | 25 | 1 | -16 | 25.4 | 1 7/16x12 | 80 | 39 | 1 3/8 | 1 5/8 |

JS ORFS Swivel Female (Long)

ISO 12151-1-SWSB
SAE J516 – ORFS

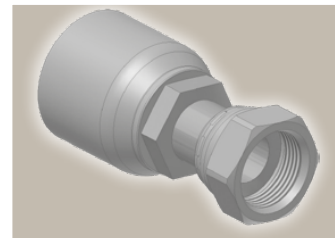
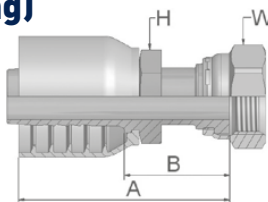

| Part Number | Hose I.D. | | | | Thread UNF | A mm | B mm | H mm Inch | W mm Inch |
|-------------|-----------|------|------|------|---------------|---------|---------|--------------|--------------|
| | DN | Inch | Size | mm | | | | | |
| 1JS43-10-10 | 16 | 5/8 | -10 | 15.9 | 1x14 | 78 | 42 | 15/16 | 1 1/8 |

Approved **fitting series** for hose types, depending on size: Also available in stainless steel. Details can be found in CAT 4400.1/UK

| | | | | | | | | | | | | | |
|----|-----|-------|-------|-------|-------|-------|-----|-------|-------|-----|-------|-------|-----|
| 43 | 304 | 387 | 387ST | 387TC | 421WC | 426 | 487 | 487ST | 487TC | 722 | 722TC | 722ST | ... |
| | 787 | 787TC | 787ST | 797 | 797TC | 797ST | 881 | | | | | | |



Cb-14

Catalogue 4400/UK

J7 Female ORFS – Swivel 45° Elbow

ISO 12151-1 – SWE 45°
SAE J516 – ORFS 45°

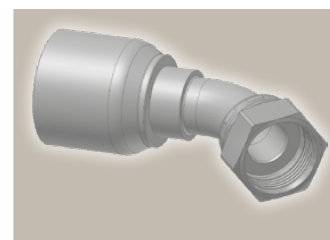
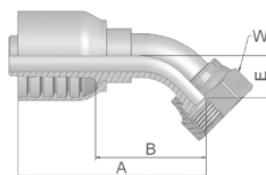

| Part Number | Hose I.D. | | | | Thread UNF | A mm | B mm | E mm | W mm |
|-------------|-----------|------|------|------|---------------|---------|---------|---------|---------|
| | DN | Inch | Size | mm | | | | | |
| 1J743-8-6 | 10 | 3/8 | -6 | 9.5 | 13/16x16 | 64 | 38 | 15 | 15/16 |
| 1J743-8-8 | 12 | 1/2 | -8 | 12.7 | 13/16x16 | 72 | 40 | 15 | 15/16 |
| 1J743-10-10 | 16 | 5/8 | -10 | 15.9 | 1x14 | 81 | 44 | 16 | 1 1/8 |
| 1J743-12-12 | 19 | 3/4 | -12 | 19.1 | 1 3/16x12 | 92 | 56 | 21 | 1 3/8 |
| 1J743-16-16 | 25 | 1 | -16 | 25.4 | 1 7/16x12 | 111 | 70 | 24 | 1 5/8 |

J9 Female ORFS – Swivel 90° Elbow – Short Drop

ISO 12151-1 – SWES
SAE J516 – ORFS 90°

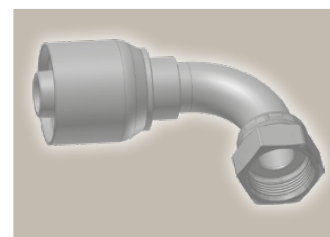
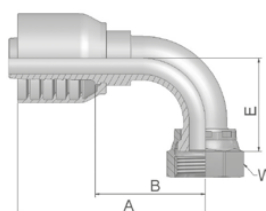

| Part Number | Hose I.D. | | | | Thread UNF | A mm | B mm | E mm | W mm |
|-------------|-----------|------|------|------|---------------|---------|---------|---------|---------|
| | DN | Inch | Size | mm | | | | | |
| 1J943-6-6 | 10 | 3/8 | -6 | 9.5 | 11/16x16 | 56 | 30 | 23 | 13/16 |
| 1J943-8-6 | 10 | 3/8 | -6 | 9.5 | 13/16x16 | 58 | 32 | 29 | 15/16 |
| 1J943-8-8 | 12 | 1/2 | -8 | 12.7 | 13/16x16 | 66 | 34 | 29 | 15/16 |
| 1J943-10-8 | 12 | 1/2 | -8 | 12.7 | 1x14 | 70 | 38 | 32 | 1 1/8 |
| 1J943-10-10 | 16 | 5/8 | -10 | 15.9 | 1x14 | 75 | 39 | 32 | 1 1/8 |
| 1J943-12-10 | 16 | 5/8 | -10 | 15.9 | 1 3/16x12 | 89 | 52 | 48 | 1 3/8 |
| 1J943-12-12 | 19 | 3/4 | -12 | 19.1 | 1 3/16x12 | 78 | 52 | 48 | 1 3/8 |
| 1J943-16-16 | 25 | 1 | -16 | 25.4 | 1 7/16x12 | 109 | 68 | 56 | 1 5/8 |

43 Series

Approved **fitting series** for hose types, depending on size: Also available in stainless steel. Details can be found in CAT 4400.1/UK

| | | | | | | | | | | | | | |
|----|-----|-------|-------|-------|-------|-------|-----|-------|-------|-----|-------|-------|-----|
| 43 | 304 | 387 | 387ST | 387TC | 421WC | 426 | 487 | 487ST | 487TC | 722 | 722TC | 722ST | ... |
| | 787 | 787TC | 787ST | 797 | 797TC | 797ST | 881 | | | | | | |





DIN – Metric

Page Cc-1 – Cc-9

| | | | |
|-------------------------------------------------------------------------------------------------------------------------------------------------------------------------------------------------------------------------|--------------------------------------------------------------------------------------------------------------------------------------------------------------------------------------------------------------------------------|-------------------------------------------------------------------------------------------------------------------------------------------------------------------------------------------------------------------------------|---------------------------------------------------------------------------------------------------------------------------------------------------------------------------------------------------------|
| <p>CA</p> <p>Cc-1</p>  <p>Female Metric 24° Light Series with O-Ring Swivel – Straight ISO 12151-2-SWS-L – DKOL</p> | <p>CE</p> <p>Cc-2</p>  <p>Female Metric 24° Light Series with O-Ring Swivel – 45° Elbow ISO 12151-2-SWE-L – DKOL 45°</p> | <p>CF</p> <p>Cc-3</p>  <p>Female Metric 24° Light Series with O-Ring Swivel – 90° Elbow ISO 12151-2-SWE-L – DKOL 90°</p> | <p>D0</p> <p>Cc-4</p>  <p>Male Metric 24° Light Series – Rigid Straight ISO 12151-2-S-L – CEL</p> |
| <p>C9</p> <p>Cc-5</p>  <p>Female Metric 24° – Swivel Heavy Series with O-Ring Straight ISO 12151-2-SWS-S – DKOS</p> | <p>0C</p> <p>Cc-6</p>  <p>Female Metric 24° – Swivel Heavy Series with O-Ring 45° Elbow ISO 12151-2 – SWE-S – DKOS 45°</p> | <p>1C</p> <p>Cc-7</p>  <p>Female Metric 24° – Swivel Heavy Series with O-Ring 90° Elbow ISO 12151-2-SWE-S – DKOS 90°</p> | <p>D2</p> <p>Cc-8</p>  <p>Male Metric 24° – Rigid Heavy Series – Straight ISO 12151-2-S-S – CES</p> |
| <p>49</p> <p>Cc-9</p>  <p>Metric Banjo Straight DIN 7642</p> | | | |

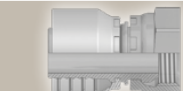

BSP

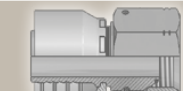
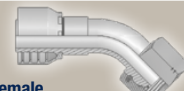
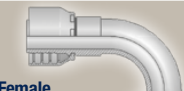
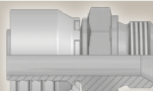
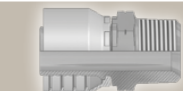
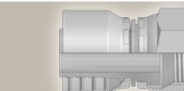
Page Cc-10 – Cc-18

| | | | |
|--------------------------------------------------------------------------------------------------------------------------------------------------------------------------------------------------------|--------------------------------------------------------------------------------------------------------------------------------------------------------------------------------------------------------------------------|---------------------------------------------------------------------------------------------------------------------------------------------------------------------------------------------------------------------------|------------------------------------------------------------------------------------------------------------------------------------------------------------------------------------------------------------------------------|
| <p>92</p> <p>Cc-10</p>  <p>Female BSP Parallel Pipe Swivel – Straight (60° Cone) BS5200-A – DKR</p> | <p>B1</p> <p>Cc-11</p>  <p>Female BSP Parallel Pipe Swivel 45° Elbow (60° Cone) BS 5200-D – DKR 45°</p> | <p>B2</p> <p>Cc-12</p>  <p>Female BSP Parallel Pipe Swivel 90° Elbow (60° Cone) BS 5200-B – DKR 90°</p> | <p>B4</p> <p>Cc-13</p>  <p>Female BSP Parallel Pipe Swivel – 90° Elbow Block Type (60° Cone) BS 5200-E – DKR 90°</p> |
| <p>EA</p> <p>Cc-14</p>  <p>BSP Swivel Female with O-Ring (60° Cone) BS 5200 – ISO 12151-6 – DKOR</p> | <p>EB</p> <p>Cc-15</p>  <p>BSP Swivel Female with O-Ring 45° Elbow (60° Cone) BS 5200 – ISO 12151-6 – DKOR 45°</p> | <p>EC</p> <p>Cc-16</p>  <p>BSP Swivel Female with O-Ring 90° Elbow (60° Cone) BS 5200 – ISO 12151-6 – DKOR 90°</p> | <p>D9</p> <p>Cc-17</p>  <p>Male BSP Parallel Pipe Rigid – Straight (60° Cone) BS5200 – AGR</p> |
| <p>91</p> <p>Cc-18</p>  <p>Male BSP Taper Pipe – Rigid Straight BS5200 – AGR-K</p> | <p>B5</p> <p>Cc-18</p>  <p>Female BSP Parallel Pipe Swivel Straight (Flat Seat)</p> | | |

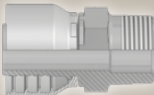
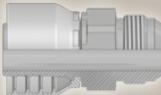
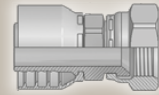
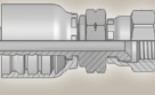
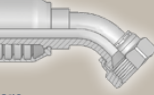
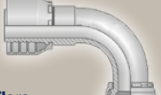

SAE

Page Cc-19 – Cc-24

| | | | |
|-----------------------------------------------------------------------------------------------------------------------------------------------------------------------------------------------------------------------------|--------------------------------------------------------------------------------------------------------------------------------------------------------------------------------------------------------------------------|--------------------------------------------------------------------------------------------------------------------------------------------------------------------------------------------------------------------|----------------------------------------------------------------------------------------------------------------------------------------------------------------------------|
| <p>01 Cc-19</p>  <p>Male NPTF Pipe Rigid – Straight SAE J476A / J516 – AGN</p> | <p>03 Cc-20</p>  <p>Male JIC 37° – Rigid Straight ISO12151-5-S – AGJ</p> | <p>06/68 Cc-21</p>  <p>Female – JIC 37° SAE 45° Dual Flare Swivel – Straight ISO12151-5-SWS – DKJ</p> | <p>08 Cc-22</p>  <p>Female SAE 45° – Swivel Straight SAE J516</p> |
| <p>37/3V Cc-22</p>  <p>Female JIC 37° SAE 45° – Dual Flare Swivel Female 45° Elbow ISO 12151-5-SWE 45° – DKJ 45°</p> | <p>39/3W Cc-23</p>  <p>Female JIC 37° SAE 45° – Dual Flare Swivel Female 90° Elbow ISO 12151-5-SWES – DKJ 90°</p> | <p>41/3Y Cc-24</p>  <p>Female JIC 37° / 45° Swivel Female 90° Elbow (Long) ISO 12151-5-SWEL – DKJ 90°L</p> | |

Flange

Page Cc-25 – Cc-29

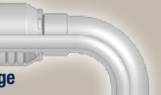
| | | | |
|------------------------------------------------------------------------------------------------------------------------------------------------------------------------------------------------------------------------------------|---------------------------------------------------------------------------------------------------------------------------------------------------------------------------------------------------------------------|--------------------------------------------------------------------------------------------------------------------------------------------------------------------------------------------------------------------|------------------------------------------------------------------------------------------------------------------------------------------------------------------------------------------------------------|
| <p>15 Cc-25</p>  <p>ISO 6162-1-Flange Straight ISO 12151-3-S-L – SFL (21.0 MPa/ 3000 psi)</p> | <p>17 Cc-26</p>  <p>ISO 6162-1 Flange 45° Elbow ISO 12151-3 – E45 – L – SFL 45° (21.0 MPa/ 3000 psi)</p> | <p>19 Cc-27</p>  <p>ISO 6162-1-Flange 90° Elbow ISO 12151-3 – E – L – SFL 90° (21.0 MPa/ 3000 psi)</p> | <p>6A Cc-28</p>  <p>ISO 6162-2-Flange Straight ISO 12151-3-S-S – SFS (42.0 MPa/ 6000 psi)</p> |
| <p>6F Cc-28</p>  <p>ISO 6162-2-Flange 45° Elbow – Heavy Series ISO 12151-3 – E45-S – SFS 45° (42.0 MPa/ 6000 psi)</p> | <p>6N Cc-29</p>  <p>ISO 6162-2-Flange 90° Elbow ISO 12151-3 – E-S – SFS 90° (42.0 MPa/ 6000 psi)</p> | | |

ORFS

Page Cc-30 – Cc-35

| | | | |
|----------------------------------------------------------------------------------------------------------------------------------------------------------------------------------------------------------------------|---------------------------------------------------------------------------------------------------------------------------------------------------------------------------------------------------------------|------------------------------------------------------------------------------------------------------------------------------------------------------------------------------------------------------------|-----------------------------------------------------------------------------------------------------------------------------------------------------------------------------------------------------------------------|
| <p>JC Cc-30</p>  <p>Female ORFS Swivel – Straight Short ISO 12151-1 – SWSA SAE J516 – ORFS</p> | <p>JS Cc-31</p>  <p>ORFS Swivel Female (Long) ISO 12151-1-SWSB SAE J516 – ORFS</p> | <p>J7 Cc-32</p>  <p>Female ORFS – Swivel 45° Elbow ISO 12151-1 – SWE 45° SAE J516 – ORFS 45°</p> | <p>J9 Cc-33</p>  <p>Female ORFS – Swivel 90° Elbow – Short Drop ISO 12151-1 – SWES SAE J516 – ORFS 90°</p> |
| <p>J1 Cc-34</p>  <p>Female ORFS – Swivel 90° Elbow – Long Drop ISO 12151-1 – SWEL SAE J516 – ORFS 90° L</p> | <p>J5 Cc-34</p>  <p>Female ORFS – Swivel 90° Elbow – Medium Drop ISO 12151-1 – SWEM – ORFS 90° M</p> | <p>JM Cc-35</p>  <p>ORFS Male ISO 12151-1-S – SAE J516</p> | <p>JD Cc-35</p>  <p>Male ORFS Bulkhead with Locknut Straight (with O-ring) ISO 12151-1 – SAE J516</p> |

46/48 Series

JIS

Page Cc-36 – Cc-37

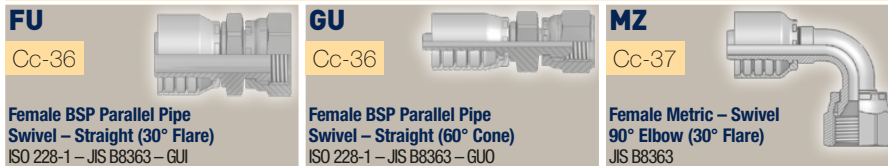

High Pressure Cleaning

Page Cc-38 – Cc-39



Others

Page Cc-40

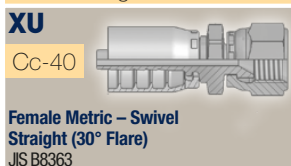

UPTC (Universal push-to-connect)

Page Cc-41 – Cc-42

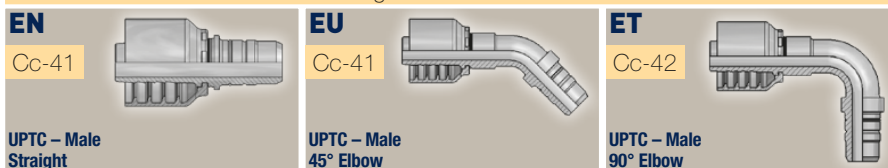

3S-FITTING DESIGN Short, Safe, Strong

Parker Integrated Backup-Hex
for Straight 48 Series
JIC/ORFS Connections

New 3S-Fittings see Cc-21 and Cc-30

- Robust with higher strength
- Fast torque assembly
- Safe use during vibration and pressure peaks
- Reduced assembly time at replacements
- Reduction of contact corrosion
- Extremely durable

Before – After Comparison

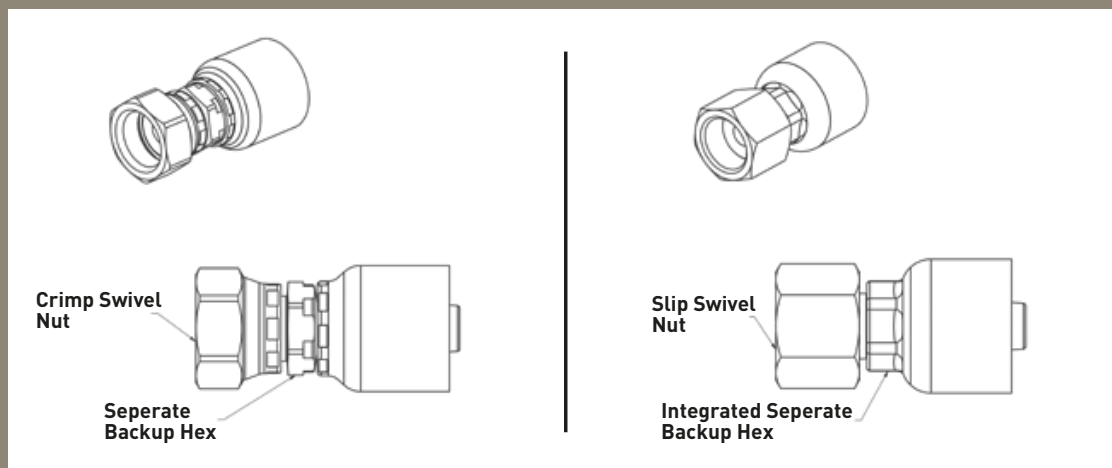

Old Design

3S-Fitting Design

46/48 Series

Medium Pressure
DIN – Metric

Parkrimp No-Skive Fittings
46/48 Series

CA **Female Metric 24°
Light Series with O-Ring
Swivel – Straight**
ISO 12151-2-SWS-L – DKOL

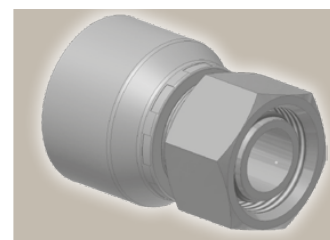
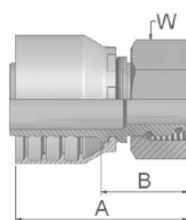

| Part Number | | Hose I.D. | | | | Thread | Tube | A | B | W |
|-------------|-------------|-----------|-------|------|------|---------|------------|----|----|----|
| 46 series | 48 series | DN | Inch | Size | mm | metric | O.D. mm | mm | mm | mm |
| 1CA46-6-4 | 1CA48-6-4 | 6 | 1/4 | -4 | 6.4 | M12x1.5 | 6 | 46 | 22 | 14 |
| 1CA46-8-4 | 1CA48-8-4 | 6 | 1/4 | -4 | 6.4 | M14x1.5 | 8 | 47 | 24 | 17 |
| 1CA46-10-4 | 1CA48-10-4 | 6 | 1/4 | -4 | 6.4 | M16x1.5 | 10 | 47 | 22 | 19 |
| 1CA46-12-4 | 1CA48-12-4 | 6 | 1/4 | -4 | 6.4 | M18x1.5 | 12 | 46 | 22 | 22 |
| 1CA46-8-5 | 1CA48-8-5 | 8 | 5/16 | -5 | 7.9 | M14x1.5 | 8 | 50 | 26 | 17 |
| 1CA46-10-5 | 1CA48-10-5 | 8 | 5/16 | -5 | 7.9 | M16x1.5 | 10 | 46 | 23 | 19 |
| 1CA46-12-5 | 1CA48-12-5 | 8 | 5/16 | -5 | 7.9 | M18x1.5 | 12 | 46 | 22 | 22 |
| 1CA46-8-6 | 1CA48-8-6 | 10 | 3/8 | -6 | 9.5 | M14x1.5 | 8 | 49 | 26 | 17 |
| 1CA46-10-6 | 1CA48-10-6 | 10 | 3/8 | -6 | 9.5 | M16x1.5 | 10 | 48 | 25 | 19 |
| 1CA46-12-6 | 1CA48-12-6 | 10 | 3/8 | -6 | 9.5 | M18x1.5 | 12 | 46 | 23 | 22 |
| 1CA46-15-6 | 1CA48-15-6 | 10 | 3/8 | -6 | 9.5 | M22x1.5 | 15 | 48 | 25 | 27 |
| 1CA46-18-6 | 1CA48-18-6 | 10 | 3/8 | -6 | 9.5 | M26x1.5 | 18 | 50 | 28 | 32 |
| 1CA46-12-8 | 1CA48-12-8 | 12 | 1/2 | -8 | 12.7 | M18x1.5 | 12 | 50 | 27 | 22 |
| 1CA46-15-8 | 1CA48-15-8 | 12 | 1/2 | -8 | 12.7 | M22x1.5 | 15 | 50 | 26 | 27 |
| 1CA46-18-8 | 1CA48-18-8 | 12 | 1/2 | -8 | 12.7 | M26x1.5 | 18 | 49 | 25 | 32 |
| 1CA46-15-10 | 1CA48-15-10 | 16 | 5/8 | -10 | 15.9 | M22x1.5 | 15 | 54 | 29 | 27 |
| 1CA46-18-10 | 1CA48-18-10 | 16 | 5/8 | -10 | 15.9 | M26x1.5 | 18 | 50 | 25 | 32 |
| 1CA46-22-10 | 1CA48-22-10 | 16 | 5/8 | -10 | 15.9 | M30x2 | 22 | 58 | 33 | 36 |
| 1CA46-18-12 | 1CA48-18-12 | 19 | 3/4 | -12 | 19.1 | M26x1.5 | 18 | 51 | 25 | 32 |
| 1CA46-22-12 | 1CA48-22-12 | 19 | 3/4 | -12 | 19.1 | M30x2 | 22 | 56 | 30 | 36 |
| 1CA46-28-12 | 1CA48-28-12 | 19 | 3/4 | -12 | 19.1 | M36x2 | 28 | 61 | 35 | 41 |
| 1CA46-22-16 | 1CA48-22-16 | 25 | 1 | -16 | 25.4 | M30x2 | 22 | 60 | 30 | 36 |
| 1CA46-28-16 | 1CA48-28-16 | 25 | 1 | -16 | 25.4 | M36x2 | 28 | 63 | 33 | 41 |
| 1CA46-35-16 | 1CA48-35-16 | 25 | 1 | -16 | 25.4 | M45x2 | 35 | 63 | 33 | 50 |
| 1CA46-35-20 | 1CA48-28-20 | 31 | 1 1/4 | -20 | 31.8 | M36x2 | 28 | 81 | 34 | 41 |
| | | 31 | 1 1/4 | -20 | 31.8 | M45x2 | 35 | 69 | 31 | 50 |
| | 1CA48-35-20 | 31 | 1 1/4 | -20 | 31.8 | M45x2 | 35 | 82 | 35 | 50 |
| | 1CA48-42-20 | 31 | 1 1/4 | -20 | 31.8 | M52x2 | 42 | 82 | 35 | 60 |
| | 1CA48-35-24 | 38 | 1 1/2 | -24 | 38.1 | M45x2 | 35 | 75 | 37 | 50 |
| | 1CA48-42-24 | 38 | 1 1/2 | -24 | 38.1 | M52x2 | 42 | 77 | 39 | 60 |

46/48 Series

Hose fittings are delivered with ozone resistant Nitrile (NBR) O-ring as a standard version. Working temperature from -40 °C up to +105 °C. Hose fittings with special O-rings (Viton or EPDM) available on request. O-ring dimensions and part-numbers see in section Eb.

Approved **fitting series** for hose types, depending on size: Also available in stainless steel. Details can be found in CAT 4400.1/UK

46 or **48** 441 461LT 462 462TC 462ST 629PU 692PU Twin

46 463 492 492ST 492TC 692 692Twin 692TC BCH1

48 301SN 304 387 387ST 387TC 421RH 421SN 426 421TC 436 441RH 462PU 462PU Twin BCH2 HT2 ...

471TC 477 477ST 477TC 477RH 487 487ST 487TC 493 787 787TC 787ST 797 797TC 797ST 811 881



Cc-1

Catalogue 4400/UK

CE **Female Metric 24°
Light Series with O-Ring
Swivel – 45° Elbow**
ISO 12151-2-SWE -L – DKOL 45°

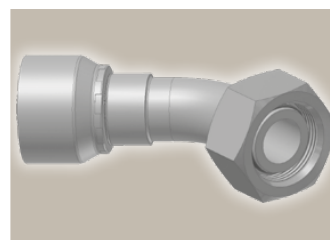
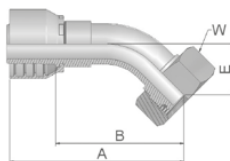

| Part Number | | Hose I.D. | | | | Thread metric | Tube | A mm | B mm | E mm | W mm |
|-------------|-------------|-----------|-------|------|------|------------------|------------|---------|---------|---------|---------|
| 46 series | 48 series | DN | Inch | Size | mm | | O.D. mm | | | | |
| 1CE46-6-4 | | 6 | 1/4 | -4 | 6.4 | M12x1.5 | 6 | 69 | 46 | 19 | 14 |
| | 1CE48-6-4 | 6 | 1/4 | -4 | 6.4 | M12x1.5 | 6 | 70 | 45 | 19 | 14 |
| 1CE46-8-4 | 1CE48-8-4 | 6 | 1/4 | -4 | 6.4 | M14x1.5 | 8 | 59 | 36 | 16 | 17 |
| 1CE46-10-4 | 1CE48-10-4 | 6 | 1/4 | -4 | 6.4 | M16x1.5 | 10 | 59 | 36 | 16 | 19 |
| 1CE46-12-4 | 1CE48-12-4 | 6 | 1/4 | -4 | 6.4 | M18x1.5 | 12 | 60 | 36 | 16 | 22 |
| 1CE46-8-5 | 1CE48-8-5 | 8 | 5/16 | -5 | 7.9 | M14x1.5 | 8 | 65 | 41 | 20 | 17 |
| 1CE46-10-5 | 1CE48-10-5 | 8 | 5/16 | -5 | 7.9 | M16x1.5 | 10 | 68 | 44 | 16 | 19 |
| 1CE46-12-5 | 1CE48-12-5 | 8 | 5/16 | -5 | 7.9 | M18x1.5 | 12 | 61 | 38 | 17 | 22 |
| 1CE46-10-6 | 1CE48-10-6 | 10 | 3/8 | -6 | 9.5 | M16x1.5 | 10 | 69 | 46 | 20 | 19 |
| 1CE46-12-6 | 1CE48-12-6 | 10 | 3/8 | -6 | 9.5 | M18x1.5 | 12 | 68 | 45 | 19 | 22 |
| 1CE46-15-6 | 1CE48-15-6 | 10 | 3/8 | -6 | 9.5 | M22x1.5 | 15 | 69 | 46 | 20 | 27 |
| 1CE46-12-8 | 1CE48-12-8 | 12 | 1/2 | -8 | 12.7 | M18x1.5 | 12 | 75 | 51 | 24 | 22 |
| 1CE46-15-8 | 1CE48-15-8 | 12 | 1/2 | -8 | 12.7 | M22x1.5 | 15 | 71 | 48 | 23 | 27 |
| 1CE46-18-8 | 1CE48-18-8 | 12 | 1/2 | -8 | 12.7 | M26x1.5 | 18 | 71 | 47 | 22 | 32 |
| 1CE46-15-10 | 1CE48-15-10 | 16 | 5/8 | -10 | 15.9 | M22x1.5 | 15 | 79 | 54 | 26 | 27 |
| 1CE46-18-10 | 1CE48-18-10 | 16 | 5/8 | -10 | 15.9 | M26x1.5 | 18 | 75 | 50 | 23 | 32 |
| 1CE46-18-12 | 1CE48-18-12 | 19 | 3/4 | -12 | 19.1 | M26x1.5 | 18 | 90 | 64 | 27 | 32 |
| 1CE46-22-12 | 1CE48-22-12 | 19 | 3/4 | -12 | 19.1 | M30x2 | 22 | 88 | 62 | 26 | 36 |
| 1CE46-28-12 | 1CE48-28-12 | 19 | 3/4 | -12 | 19.1 | M36x2 | 28 | 90 | 64 | 28 | 41 |
| 1CE46-22-16 | 1CE48-22-16 | 25 | 1 | -16 | 25.4 | M30x2 | 22 | 112 | 82 | 35 | 36 |
| 1CE46-28-16 | | 25 | 1 | -16 | 25.4 | M36x 2 | 28 | 113 | 83 | 33 | 41 |
| | 1CE48-28-16 | 25 | 1 | -16 | 25.4 | M36x2 | 28 | 113 | 83 | 33 | 41 |
| | 1CE48-28-20 | 31 | 1 1/4 | -20 | 31.8 | M36x2 | 28 | 142 | 95 | 39 | 41 |
| 1CE46-35-20 | | 31 | 1 1/4 | -20 | 31.8 | M45x2 | 35 | 130 | 92 | 32 | 50 |
| | 1CE48-35-20 | 31 | 1 1/4 | -20 | 31.8 | M45x2 | 35 | 141 | 94 | 37 | 50 |
| | 1CE48-42-24 | 38 | 1 1/2 | -24 | 38.1 | M52x2 | 42 | 155 | 117 | 49 | 60 |

Hose fittings are delivered with ozone resistant Nitrile (NBR) O-ring as a standard version. Working temperature from -40 °C up to +105 °C.
Hose fittings with special O-rings (Viton or EPDM) available on request. O-ring dimensions and part-numbers see in section Eb.

Approved **fitting series** for hose types, depending on size: Also available in stainless steel. Details can be found in CAT 4400.1/UK

46 or **48** 441 461LT 462 462TC 462ST 629PU 692PU Twin

46 463 492 492ST 492TC 692 692Twin 692TC BCH1

48 301SN 304 387 387ST 387TC 421RH 421SN 426 421TC 436 441RH 462PU 462PU Twin BCH2 HT2 ...

471TC 477 477ST 477TC 477RH 487 487ST 487TC 493 787 787TC 787ST 797 797TC 797ST 811 881



Medium Pressure
DIN – Metric

Parkrimp No-Skive Fittings
46/48 Series

CF **Female Metric 24°
Light Series with O-Ring
Swivel – 90° Elbow**
ISO 12151-2-SWE-L – DKOL 90°

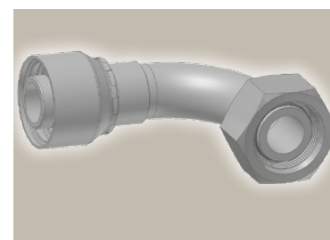
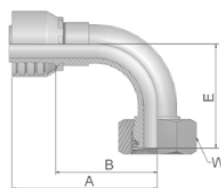

| Part Number | | Hose I.D. | | | | Thread | Tube | A | B | E | W |
|-------------|-------------|-----------|-------|------|------|---------|------------|-----|-----|-----|----|
| 46 series | 48 series | DN | Inch | Size | mm | metric | O.D. mm | mm | mm | mm | mm |
| 1CF46-6-4 | 1CF48-6-4 | 6 | 1/4 | -4 | 6.4 | M12x1.5 | 6 | 57 | 33 | 33 | 14 |
| 1CF46-8-4 | 1CF48-8-4 | 6 | 1/4 | -4 | 6.4 | M14x1.5 | 8 | 51 | 28 | 29 | 17 |
| 1CF46-10-4 | 1CF48-10-4 | 6 | 1/4 | -4 | 6.4 | M16x1.5 | 10 | 52 | 28 | 30 | 19 |
| 1CF46-12-4 | 1CF48-12-4 | 6 | 1/4 | -4 | 6.4 | M18x1.5 | 12 | 53 | 26 | 29 | 22 |
| 1CF46-8-5 | 1CF48-8-5 | 8 | 5/16 | -5 | 7.9 | M14x1.5 | 8 | 62 | 38 | 35 | 17 |
| 1CF46-10-5 | 1CF48-10-5 | 8 | 5/16 | -5 | 7.9 | M16x1.5 | 10 | 61 | 37 | 30 | 19 |
| 1CF46-12-5 | 1CF48-12-5 | 8 | 5/16 | -5 | 7.9 | M18x1.5 | 12 | 60 | 37 | 30 | 22 |
| 1CF46-10-6 | 1CF48-10-6 | 10 | 3/8 | -6 | 9.5 | M16x1.5 | 10 | 60 | 37 | 38 | 19 |
| 1CF46-12-6 | 1CF48-12-6 | 10 | 3/8 | -6 | 9.5 | M18x1.5 | 12 | 58 | 36 | 35 | 22 |
| 1CF46-15-6 | 1CF48-15-6 | 10 | 3/8 | -6 | 9.5 | M22x1.5 | 15 | 58 | 35 | 37 | 27 |
| 1CF46-12-8 | 1CF48-12-8 | 12 | 1/2 | -8 | 12.7 | M18x1.5 | 12 | 63 | 39 | 45 | 22 |
| 1CF46-15-8 | 1CF48-15-8 | 12 | 1/2 | -8 | 12.7 | M22x1.5 | 15 | 61 | 37 | 43 | 27 |
| 1CF46-18-8 | 1CF48-18-8 | 12 | 1/2 | -8 | 12.7 | M26x1.5 | 18 | 65 | 41 | 43 | 32 |
| 1CF46-15-10 | 1CF48-15-10 | 16 | 5/8 | -10 | 15.9 | M22x1.5 | 15 | 67 | 42 | 51 | 27 |
| 1CF46-18-10 | 1CF48-18-10 | 16 | 5/8 | -10 | 15.9 | M26x1.5 | 18 | 66 | 41 | 45 | 32 |
| 1CF46-22-10 | 1CF48-22-10 | 16 | 5/8 | -10 | 15.9 | M30x2 | 22 | 71 | 46 | 47 | 36 |
| 1CF46-18-12 | 1CF48-18-12 | 19 | 3/4 | -12 | 19.1 | M26x1.5 | 18 | 80 | 54 | 56 | 32 |
| 1CF46-22-12 | 1CF48-22-12 | 19 | 3/4 | -12 | 19.1 | M30x2 | 22 | 80 | 54 | 55 | 36 |
| 1CF46-28-12 | 1CF48-28-12 | 19 | 3/4 | -12 | 19.1 | M36x2 | 28 | 80 | 54 | 57 | 41 |
| 1CF46-22-16 | 1CF48-22-16 | 25 | 1 | -16 | 25.4 | M30x2 | 22 | 102 | 72 | 74 | 36 |
| 1CF46-28-16 | 1CF48-28-16 | 25 | 1 | -16 | 25.4 | M36x2 | 28 | 101 | 72 | 71 | 41 |
| | 1CF48-22-20 | 31 | 1 1/4 | -20 | 31.8 | M30x2 | 22 | 130 | 83 | 81 | 36 |
| 1CF46-28-20 | | 31 | 1 1/4 | -20 | 31.8 | M36x2 | 28 | 124 | 86 | 81 | 41 |
| | 1CF48-28-20 | 31 | 1 1/4 | -20 | 31.8 | M36x2 | 28 | 129 | 82 | 81 | 41 |
| 1CF46-35-20 | | 31 | 1 1/4 | -20 | 31.8 | M45x2 | 35 | 124 | 86 | 79 | 50 |
| | 1CF48-35-20 | 31 | 1 1/4 | -20 | 31.8 | M45x2 | 35 | 130 | 83 | 79 | 50 |
| | 1CF48-35-24 | 38 | 1 1/2 | -24 | 38.1 | M45x2 | 35 | 139 | 101 | 99 | 50 |
| | 1CF48-42-24 | 38 | 1 1/2 | -24 | 38.1 | M52x2 | 42 | 139 | 101 | 101 | 60 |

46/48 Series

Hose fittings are delivered with ozone resistant Nitrile (NBR) O-ring as a standard version. Working temperature from -40 °C up to +105 °C. Hose fittings with special O-rings (Viton or EPDM) available on request. O-ring dimensions and part-numbers see in section Eb.

Approved **fitting series** for hose types, depending on size: Also available in stainless steel. Details can be found in CAT 4400.1/UK

46 or **48** 441 461LT 462 462TC 462ST 629PU 692PU Twin

46 463 492 492ST 492TC 692 692Twin 692TC BCH1

48 301SN 304 387 387ST 387TC 421RH 421SN 426 421TC 436 441RH 462PU 462PU Twin BCH2 HT2 ...

471TC 477 477ST 477TC 477RH 487 487ST 487TC 493 787 787TC 787ST 797 797TC 797ST 811 881



Cc-3

Catalogue 4400/UK

D0 **Male Metric 24°**
Light Series – Rigid
Straight
ISO 12151-2-S-L – CEL

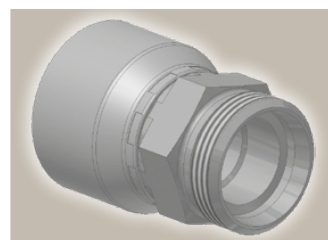
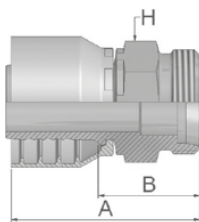

| Part Number | | Hose I.D. | | | | Thread | Tube O.D. | A | B | H |
|-------------|-------------|-----------|-------|------|------|---------|-----------|----|----|----|
| 46 series | 48 series | DN | Inch | Size | mm | metric | mm | mm | mm | mm |
| 1D046-6-4 | 1D048-6-4 | 6 | 1/4 | -4 | 6.4 | M12x1.5 | 6 | 44 | 20 | 12 |
| 1D046-8-4 | 1D048-8-4 | 6 | 1/4 | -4 | 6.4 | M14x1.5 | 8 | 46 | 22 | 14 |
| 1D046-10-4 | 1D048-10-4 | 6 | 1/4 | -4 | 6.4 | M16x1.5 | 10 | 48 | 24 | 17 |
| 1D046-12-4 | 1D048-12-4 | 6 | 1/4 | -4 | 6.4 | M18x1.5 | 12 | 48 | 24 | 19 |
| 1D046-8-5 | 1D048-8-5 | 8 | 5/16 | -5 | 7.9 | M14x1.5 | 8 | 44 | 20 | 14 |
| 1D046-10-5 | | 8 | 5/16 | -5 | 7.9 | M16x1.5 | 10 | 47 | 24 | 17 |
| | 1D048-10-5 | 8 | 5/16 | -5 | 7.9 | M16x1.5 | 10 | 48 | 24 | 17 |
| 1D046-12-5 | 1D048-12-5 | 8 | 5/16 | -5 | 7.9 | M18x1.5 | 12 | 48 | 24 | 19 |
| 1D046-10-6 | 1D048-10-6 | 10 | 3/8 | -6 | 9.5 | M16x1.5 | 10 | 47 | 24 | 17 |
| 1D046-12-6 | 1D048-12-6 | 10 | 3/8 | -6 | 9.5 | M18x1.5 | 12 | 47 | 24 | 19 |
| 1D046-15-6 | 1D048-15-6 | 10 | 3/8 | -6 | 9.5 | M22x1.5 | 15 | 49 | 26 | 22 |
| 1D046-12-8 | | 12 | 1/2 | -8 | 12.7 | M18x1.5 | 12 | 47 | 23 | 19 |
| 1D046-15-8 | 1D048-15-8 | 12 | 1/2 | -8 | 12.7 | M22x1.5 | 15 | 50 | 26 | 22 |
| 1D046-18-8 | 1D048-18-8 | 12 | 1/2 | -8 | 12.7 | M26x1.5 | 18 | 53 | 29 | 27 |
| 1D046-15-10 | 1D048-15-10 | 16 | 5/8 | -10 | 15.9 | M22x1.5 | 15 | 57 | 29 | 27 |
| 1D046-18-10 | 1D048-18-10 | 16 | 5/8 | -10 | 15.9 | M26x1.5 | 18 | 54 | 29 | 27 |
| 1D046-18-12 | 1D048-18-12 | 19 | 3/4 | -12 | 19.1 | M26x1.5 | 18 | 55 | 29 | 27 |
| 1D046-22-12 | 1D048-22-12 | 19 | 3/4 | -12 | 19.1 | M30x2 | 22 | 59 | 33 | 30 |
| 1D046-28-12 | 1D048-28-12 | 19 | 3/4 | -12 | 19.1 | M36x2 | 28 | 60 | 34 | 36 |
| 1D046-28-16 | 1D048-28-16 | 25 | 1 | -16 | 25.4 | M36x2 | 28 | 65 | 35 | 36 |
| 1D046-35-20 | | 31 | 1 1/4 | -20 | 31.8 | M45x2 | 35 | 78 | 40 | 46 |
| | 1D048-35-20 | 31 | 1 1/4 | -20 | 31.8 | M45x2 | 35 | 85 | 38 | 46 |
| | 1D048-42-24 | 38 | 1 1/2 | -24 | 38.1 | M52x2 | 42 | 77 | 39 | 55 |

Approved **fitting series** for hose types, depending on size: Also available in stainless steel. Details can be found in CAT 4400.1/UK

46 or **48** 441 | 461LT | 462 | 462TC | 462ST | 629PU | 692PU Twin

46 463 | 492 | 492ST | 492TC | 692 | 692Twin | 692TC | BCH1

48 301SN | 304 | 387 | 387ST | 387TC | 421RH | 421SN | 426 | 421TC | 436 | 441RH | 462PU | 462PU Twin | BCH2 | HT2 | ...

471TC | 477 | 477ST | 477TC | 477RH | 487 | 487ST | 487TC | 493 | 787 | 787TC | 787ST | 797 | 797TC | 797ST | 811 | 881



C9 Female Metric 24° – Swivel Heavy Series with O-Ring Straight

ISO 12151-2-SWS-S – DKOS

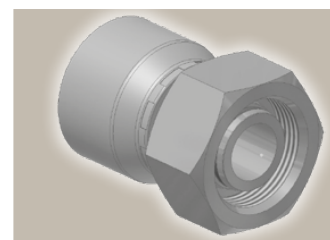
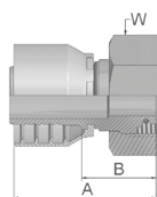

| Part Number | | Hose I.D. | | | | Thread | Tube | A | B | W |
|-------------|-------------|-----------|-------|------|------|---------|------------|----|----|----|
| 46 series | 48 series | DN | Inch | Size | mm | metric | O.D. mm | mm | mm | mm |
| 1C946-6-4 | | 6 | 1/4 | -4 | 6.4 | M14x1.5 | 6 | 48 | 26 | 17 |
| | 1C948-6-4 | 6 | 1/4 | -4 | 6.4 | M14x1.5 | 6 | 49 | 26 | 17 |
| 1C946-8-4 | 1C948-8-4 | 6 | 1/4 | -4 | 6.4 | M16x1.5 | 8 | 47 | 23 | 19 |
| 1C946-10-4 | 1C948-10-4 | 6 | 1/4 | -4 | 6.4 | M18x1.5 | 10 | 46 | 22 | 22 |
| 1C946-12-4 | 1C948-12-4 | 6 | 1/4 | -4 | 6.4 | M20x1.5 | 12 | 47 | 24 | 24 |
| 1C946-14-4 | 1C948-14-4 | 6 | 1/4 | -4 | 6.4 | M22x1.5 | 14 | 48 | 24 | 27 |
| 1C946-8-5 | 1C948-8-5 | 8 | 5/16 | -5 | 7.9 | M16x1.5 | 8 | 46 | 23 | 19 |
| 1C946-10-5 | 1C948-10-5 | 8 | 5/16 | -5 | 7.9 | M18x1.5 | 10 | 46 | 22 | 22 |
| 1C946-12-5 | 1C948-12-5 | 8 | 5/16 | -5 | 7.9 | M20x1.5 | 12 | 48 | 24 | 24 |
| 1C946-14-5 | 1C948-14-5 | 8 | 5/16 | -5 | 7.9 | M22x1.5 | 14 | 48 | 24 | 27 |
| 1C946-16-5 | 1C948-16-5 | 8 | 5/16 | -5 | 7.9 | M24x1.5 | 16 | 52 | 28 | 30 |
| 1C946-8-6 | 1C948-8-6 | 10 | 3/8 | -6 | 9.5 | M16x1.5 | 8 | 49 | 26 | 19 |
| 1C946-10-6 | 1C948-10-6 | 10 | 3/8 | -6 | 9.5 | M18x1.5 | 10 | 45 | 22 | 22 |
| 1C946-12-6 | 1C948-12-6 | 10 | 3/8 | -6 | 9.5 | M20x1.5 | 12 | 47 | 24 | 24 |
| 1C946-14-6 | 1C948-14-6 | 10 | 3/8 | -6 | 9.5 | M22x1.5 | 14 | 47 | 24 | 27 |
| 1C946-16-6 | 1C948-16-6 | 10 | 3/8 | -6 | 9.5 | M24x1.5 | 16 | 50 | 28 | 30 |
| 1C946-12-8 | 1C948-12-8 | 12 | 1/2 | -8 | 12.7 | M20x1.5 | 12 | 51 | 28 | 24 |
| 1C946-14-8 | 1C948-14-8 | 12 | 1/2 | -8 | 12.7 | M22x1.5 | 14 | 48 | 24 | 27 |
| 1C946-16-8 | 1C948-16-8 | 12 | 1/2 | -8 | 12.7 | M24x1.5 | 16 | 51 | 28 | 30 |
| 1C946-20-8 | 1C948-20-8 | 12 | 1/2 | -8 | 12.7 | M30x2 | 20 | 53 | 29 | 36 |
| 1C946-16-10 | 1C948-16-10 | 16 | 5/8 | -10 | 15.9 | M24x1.5 | 16 | 53 | 28 | 30 |
| 1C946-20-10 | 1C948-20-10 | 16 | 5/8 | -10 | 15.9 | M30x2 | 20 | 53 | 28 | 36 |
| | 1C948-12-12 | 19 | 3/4 | -12 | 19.1 | M20x1.5 | 12 | 53 | 28 | 24 |
| | 1C948-16-12 | 19 | 3/4 | -12 | 19.1 | M24x1.5 | 16 | 55 | 29 | 30 |
| 1C946-20-12 | 1C948-20-12 | 19 | 3/4 | -12 | 19.1 | M30x2 | 20 | 56 | 30 | 36 |
| 1C946-25-12 | 1C948-25-12 | 19 | 3/4 | -12 | 19.1 | M36x2 | 25 | 61 | 35 | 46 |
| 1C946-25-16 | 1C948-25-16 | 25 | 1 | -16 | 25.4 | M36x2 | 25 | 63 | 33 | 46 |
| 1C946-30-16 | 1C948-30-16 | 25 | 1 | -16 | 25.4 | M42x2 | 30 | 67 | 38 | 50 |
| | 1C948-25-20 | 31 | 1 1/4 | -20 | 31.8 | M36x2 | 25 | 81 | 34 | 46 |
| 1C946-38-20 | | 31 | 1 1/4 | -20 | 31.8 | M52x2 | 38 | 74 | 36 | 60 |
| | 1C948-38-20 | 31 | 1 1/4 | -20 | 31.8 | M52x2 | 38 | 80 | 33 | 60 |

46/48 Series

Hose fittings are delivered with ozone resistant Nitrile (NBR) O-ring as a standard version. Working temperature from -40 °C up to +105 °C. Hose fittings with special O-rings (Viton or EPDM) available on request. O-ring dimensions and part-numbers see in section Eb.

Approved **fitting series** for hose types, depending on size: Also available in stainless steel. Details can be found in CAT 4400.1/UK

46 or **48** 441 461LT 462 462TC 462ST 629PU 692PU Twin

46 463 492 492ST 492TC 692 692Twin 692TC BCH1

48 301SN 304 387 387ST 387TC 421RH 421SN 426 421TC 436 441RH 462PU 462PU Twin BCH2 HT2 ...

471TC 477 477ST 477TC 477RH 487 487ST 487TC 493 787 787TC 787ST 797 797TC 797ST 811 881



OC Female Metric 24° – Swivel Heavy Series with O-Ring 45° Elbow

ISO 12151-2 – SWE -S – DKOS 45°

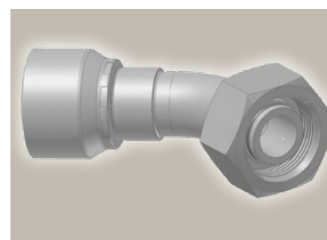
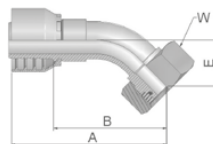

| Part Number | | Hose I.D. | | | | Thread | Tube | A | B | E | W |
|-------------|-------------|-----------|-------|------|------|---------|---------|-----|-----|----|----|
| 46 series | 48 series | DN | Inch | Size | mm | metric | O.D. mm | mm | mm | mm | mm |
| 10C46-6-4 | 10C48-6-4 | 6 | 1/4 | -4 | 6.4 | M14x1.5 | 6 | 61 | 38 | 16 | 17 |
| 10C46-8-4 | 10C48-8-4 | 6 | 1/4 | -4 | 6.4 | M16x1.5 | 8 | 59 | 35 | 16 | 19 |
| 10C46-10-4 | 10C48-10-4 | 6 | 1/4 | -4 | 6.4 | M18x1.5 | 10 | 59 | 36 | 16 | 22 |
| 10C46-12-4 | 10C48-12-4 | 6 | 1/4 | -4 | 6.4 | M20x1.5 | 12 | 71 | 48 | 17 | 24 |
| 10C46-10-5 | 10C48-10-5 | 8 | 5/16 | -5 | 7.9 | M18x1.5 | 10 | 62 | 38 | 17 | 22 |
| 10C46-12-5 | 10C48-12-5 | 8 | 5/16 | -5 | 7.9 | M20x1.5 | 12 | 70 | 47 | 17 | 24 |
| 10C46-10-6 | 10C48-10-6 | 10 | 3/8 | -6 | 9.5 | M18x1.5 | 10 | 70 | 47 | 19 | 22 |
| 10C46-12-6 | 10C48-12-6 | 10 | 3/8 | -6 | 9.5 | M20x1.5 | 12 | 69 | 46 | 20 | 24 |
| 10C46-14-6 | 10C48-14-6 | 10 | 3/8 | -6 | 9.5 | M22x1.5 | 14 | 69 | 46 | 20 | 27 |
| 10C46-14-8 | 10C48-14-8 | 12 | 1/2 | -8 | 12.7 | M22x1.5 | 14 | 69 | 46 | 21 | 27 |
| 10C46-16-8 | 10C48-16-8 | 12 | 1/2 | -8 | 12.7 | M24x1.5 | 16 | 72 | 49 | 23 | 30 |
| 10C46-16-10 | 10C48-16-10 | 16 | 5/8 | -10 | 15.9 | M24x1.5 | 16 | 77 | 52 | 24 | 30 |
| 10C46-20-10 | 10C48-20-10 | 16 | 5/8 | -10 | 15.9 | M30x2 | 20 | 76 | 51 | 25 | 36 |
| 10C46-20-12 | 10C48-20-12 | 19 | 3/4 | -12 | 19.1 | M30x2 | 20 | 90 | 64 | 28 | 36 |
| 10C46-25-12 | 10C48-25-12 | 19 | 3/4 | -12 | 19.1 | M36x2 | 25 | 91 | 65 | 29 | 46 |
| | 10C48-30-12 | 19 | 3/4 | -12 | 19.1 | M42x2 | 30 | 93 | 67 | 30 | 50 |
| 10C46-25-16 | | 25 | 1 | -16 | 25.4 | M36x2 | 25 | 109 | 80 | 33 | 46 |
| | 10C48-25-16 | 25 | 1 | -16 | 25.4 | M36x2 | 30 | 109 | 80 | 33 | 46 |
| 10C46-30-16 | 10C48-30-16 | 25 | 1 | -16 | 25.4 | M42x2 | 30 | 115 | 86 | 36 | 50 |
| 10C46-38-20 | | 31 | 1 1/4 | -20 | 31.8 | M52x2 | 38 | 136 | 98 | 38 | 60 |
| | 10C48-38-20 | 31 | 1 1/4 | -20 | 31.8 | M52x2 | 38 | 140 | 93 | 37 | 60 |
| | 10C48-38-24 | 38 | 1 1/2 | -24 | 38.1 | M52x2 | 38 | 155 | 117 | 49 | 60 |

Hose fittings are delivered with ozone resistant Nitrile (NBR) O-ring as a standard version. Working temperature from -40 °C up to +105 °C. Hose fittings with special O-rings (Viton or EPDM) available on request. O-ring dimensions and part-numbers see in section Eb.

Approved **fitting series** for hose types, depending on size: Also available in stainless steel. Details can be found in CAT 4400.1/UK

46 or **48** 441 461LT 462 462TC 462ST 629PU 692PU Twin

46 463 492 492ST 492TC 692 692Twin 692TC BCH1

48 301SN 304 387 387ST 387TC 421RH 421SN 426 421TC 436 441RH 462PU 462PU Twin BCH2 HT2 ...

471TC 477 477ST 477TC 477RH 487 487ST 487TC 493 787 787TC 787ST 797 797TC 797ST 811 881



1C Female Metric 24° – Swivel Heavy Series with O-Ring 90° Elbow

ISO 12151-2-SWE-S – DKOS 90°

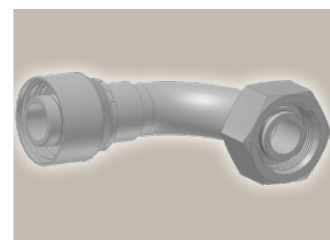
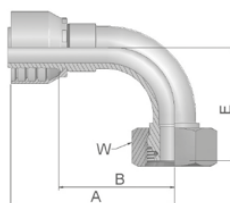

| Part Number | | Hose I.D. | | | | Thread | Tube | A | B | E | W |
|-------------|-------------|-----------|-------|------|------|---------|---------|-----|-----|-----|----|
| 46 series | 48 series | DN | Inch | Size | mm | metric | O.D. mm | mm | mm | mm | mm |
| 11C46-6-4 | 11C48-6-4 | 6 | 1/4 | -4 | 6.4 | M14x1.5 | 6 | 62 | 39 | 32 | 17 |
| 11C46-8-4 | 11C48-8-4 | 6 | 1/4 | -4 | 6.4 | M16x1.5 | 8 | 50 | 26 | 29 | 19 |
| 11C46-10-4 | 11C48-10-4 | 6 | 1/4 | -4 | 6.4 | M18x1.5 | 10 | 50 | 26 | 29 | 22 |
| 11C46-12-4 | 11C48-12-4 | 6 | 1/4 | -4 | 6.4 | M20x1.5 | 12 | 60 | 38 | 30 | 24 |
| 11C46-10-5 | 11C48-10-5 | 8 | 5/16 | -5 | 7.9 | M18x1.5 | 10 | 60 | 36 | 31 | 22 |
| 11C46-12-5 | 11C48-12-5 | 8 | 5/16 | -5 | 7.9 | M20x1.5 | 12 | 60 | 36 | 32 | 24 |
| 11C46-10-6 | 11C48-10-6 | 10 | 3/8 | -6 | 9.5 | M18x1.5 | 10 | 59 | 37 | 36 | 22 |
| 11C46-12-6 | 11C48-12-6 | 10 | 3/8 | -6 | 9.5 | M20x1.5 | 12 | 58 | 35 | 37 | 24 |
| 11C46-14-6 | 11C48-14-6 | 10 | 3/8 | -6 | 9.5 | M22x1.5 | 14 | 58 | 35 | 37 | 27 |
| | 11C48-16-6 | 10 | 3/8 | -6 | 9.5 | M24x1.5 | 16 | 63 | 38 | 40 | 30 |
| | 11C48-12-8 | 12 | 1/2 | -8 | 12.7 | M20x1.5 | 12 | 63 | 39 | 44 | 24 |
| 11C46-14-8 | 11C48-14-8 | 12 | 1/2 | -8 | 12.7 | M22x1.5 | 14 | 62 | 38 | 42 | 27 |
| 11C46-16-8 | 11C48-16-8 | 12 | 1/2 | -8 | 12.7 | M24x1.5 | 16 | 61 | 37 | 45 | 30 |
| 11C46-20-8 | 11C48-20-8 | 12 | 1/2 | -8 | 12.7 | M30x2 | 20 | 61 | 37 | 46 | 36 |
| 11C46-16-10 | 11C48-16-10 | 16 | 5/8 | -10 | 15.9 | M24x1.5 | 16 | 66 | 41 | 48 | 30 |
| 11C46-20-10 | 11C48-20-10 | 16 | 5/8 | -10 | 15.9 | M30x2 | 20 | 65 | 40 | 48 | 36 |
| 11C46-25-10 | 11C48-25-10 | 16 | 5/8 | -10 | 15.9 | M36x2 | 25 | 76 | 51 | 52 | 46 |
| 11C46-20-12 | 11C48-20-12 | 19 | 3/4 | -12 | 19.1 | M30x2 | 20 | 79 | 54 | 58 | 36 |
| 11C46-25-12 | 11C48-25-12 | 19 | 3/4 | -12 | 19.1 | M36x2 | 25 | 80 | 54 | 59 | 46 |
| | 11C48-30-12 | 19 | 3/4 | -12 | 19.1 | M42x2 | 30 | 80 | 55 | 61 | 50 |
| 11C46-25-16 | 11C48-25-16 | 25 | 1 | -16 | 25.4 | M36x2 | 25 | 102 | 72 | 71 | 46 |
| 11C46-30-16 | 11C48-30-16 | 25 | 1 | -16 | 25.4 | M42x2 | 30 | 104 | 75 | 75 | 50 |
| | 11C48-30-20 | 31 | 1 1/4 | -20 | 31.8 | M42x2 | 30 | 130 | 83 | 86 | 50 |
| 11C46-38-20 | | 31 | 1 1/4 | -20 | 31.8 | M52x2 | 38 | 124 | 86 | 80 | 60 |
| | 11C48-38-20 | 31 | 1 1/4 | -20 | 31.8 | M52x2 | 38 | 130 | 83 | 78 | 60 |
| | 11C48-38-24 | 38 | 1 1/2 | -24 | 38.1 | M52x2 | 38 | 139 | 101 | 101 | 60 |

46/48 Series

Hose fittings are delivered with ozone resistant Nitrile (NBR) O-ring as a standard version. Working temperature from -40 °C up to +105 °C. Hose fittings with special O-rings (Viton or EPDM) available on request. O-ring dimensions and part-numbers see in section Eb.

Approved **fitting series** for hose types, depending on size: Also available in stainless steel. Details can be found in CAT 4400.1/UK

46 or **48** 441 461LT 462 462TC 462ST 629PU 692PU Twin

46 463 492 492ST 492TC 692 692Twin 692TC BCH1

48 301SN 304 387 387ST 387TC 421RH 421SN 426 421TC 436 441RH 462PU 462PU Twin BCH2 HT2 ...

471TC 477 477ST 477TC 477RH 487 487ST 487TC 493 787 787TC 787ST 797 797TC 797ST 811 881



D2 Male Metric 24° – Rigid Heavy Series – Straight

ISO 12151-2-S-S – CES

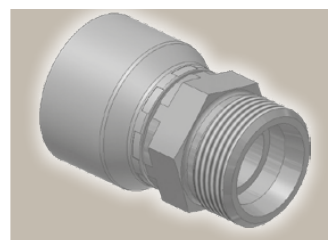
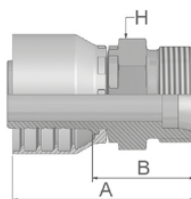

| Part Number | | Hose I.D. | | | | Thread | Tube O.D. | A | B | H |
|-------------|-------------|-----------|-------|------|------|---------|-----------|----|----|----|
| 46 series | 48 series | DN | Inch | Size | mm | metric | mm | mm | mm | mm |
| 1D246-6-4 | 1D248-6-4 | 6 | 1/4 | -4 | 6.4 | M14x1.5 | 6 | 48 | 24 | 14 |
| 1D246-8-4 | 1D248-8-4 | 6 | 1/4 | -4 | 6.4 | M16x1.5 | 8 | 48 | 24 | 17 |
| 1D246-10-4 | 1D248-10-4 | 6 | 1/4 | -4 | 6.4 | M18x1.5 | 10 | 50 | 26 | 19 |
| 1D246-12-4 | 1D248-12-4 | 6 | 1/4 | -4 | 6.4 | M20x1.5 | 12 | 48 | 26 | 22 |
| 1D246-8-5 | 1D248-8-5 | 8 | 5/16 | -5 | 7.9 | M16x1.5 | 8 | 48 | 24 | 17 |
| 1D246-10-5 | 1D248-10-5 | 8 | 5/16 | -5 | 7.9 | M18x1.5 | 10 | 50 | 26 | 19 |
| 1D246-12-5 | 1D248-12-5 | 8 | 5/16 | -5 | 7.9 | M20x1.5 | 12 | 50 | 26 | 22 |
| 1D246-14-5 | 1D248-14-5 | 8 | 5/16 | -5 | 7.9 | M22x1.5 | 14 | 51 | 28 | 22 |
| | 1D248-16-5 | 8 | 5/16 | -5 | 7.9 | M24x1.5 | 16 | 53 | 29 | 24 |
| 1D246-10-6 | 1D248-10-6 | 10 | 3/8 | -6 | 9.5 | M18x1.5 | 10 | 50 | 27 | 19 |
| 1D246-12-6 | 1D248-12-6 | 10 | 3/8 | -6 | 9.5 | M20x1.5 | 12 | 49 | 26 | 22 |
| 1D246-14-6 | 1D248-14-6 | 10 | 3/8 | -6 | 9.5 | M22x1.5 | 14 | 51 | 28 | 22 |
| 1D246-12-8 | 1D248-12-8 | 12 | 1/2 | -8 | 12.7 | M20x1.5 | 12 | 49 | 26 | 22 |
| | 1D248-14-8 | 12 | 1/2 | -8 | 12.7 | M22x1.5 | 14 | 52 | 28 | 22 |
| 1D246-16-8 | 1D248-16-8 | 12 | 1/2 | -8 | 12.7 | M24x1.5 | 16 | 52 | 29 | 24 |
| | 1D248-20-8 | 12 | 1/2 | -8 | 12.7 | M30x2 | 20 | 58 | 35 | 30 |
| 1D246-16-10 | 1D248-16-10 | 16 | 5/8 | -10 | 15.9 | M24x1.5 | 16 | 58 | 30 | 24 |
| 1D246-20-10 | 1D248-20-10 | 16 | 5/8 | -10 | 15.9 | M30x2 | 20 | 58 | 32 | 30 |
| | 1D248-16-12 | 19 | 3/4 | -12 | 19.1 | M24x1.5 | 16 | 56 | 31 | 27 |
| 1D246-20-12 | 1D248-20-12 | 19 | 3/4 | -12 | 19.1 | M30x2 | 20 | 61 | 35 | 30 |
| 1D246-25-12 | 1D248-25-12 | 19 | 3/4 | -12 | 19.1 | M36x2 | 25 | 64 | 38 | 36 |
| 1D246-25-16 | 1D248-25-16 | 25 | 1 | -16 | 25.4 | M36x2 | 25 | 68 | 39 | 36 |
| 1D246-30-16 | 1D248-30-16 | 25 | 1 | -16 | 25.4 | M42x2 | 30 | 71 | 42 | 46 |
| 1D246-38-20 | | 31 | 1 1/4 | -20 | 31.8 | M52x2 | 38 | 84 | 46 | 55 |
| | 1D248-38-20 | 31 | 1 1/4 | -20 | 31.8 | M52x2 | 38 | 91 | 44 | 55 |
| | 1D248-38-24 | 38 | 1 1/2 | -24 | 38.1 | M52x2 | 38 | 84 | 46 | 55 |

Approved **fitting series** for hose types, depending on size: Also available in stainless steel. Details can be found in CAT 4400.1/UK

46 or **48** 441 461LT 462 462TC 462ST 629PU 692PU Twin

46 463 492 492ST 492TC 692 692Twin 692TC BCH1

48 301SN 304 387 387ST 387TC 421RH 421SN 426 421TC 436 441RH 462PU 462PU Twin BCH2 HT2 ...

471TC 477 477ST 477TC 477RH 487 487ST 487TC 493 787 787TC 787ST 797 797TC 797ST 811 881



Medium Pressure
DIN – Metric

Parkrimp No-Skive Fittings
46/48 Series

49 Metric Banjo Straight

DIN 7642

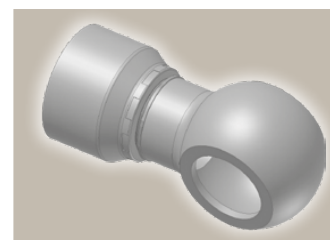
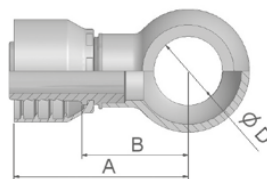

| Part Number | | Hose I.D. | | | | A | B | D |
|-------------|-------------|---------------|------|------|------|------|----|------|
| 46 series | 48 series | DN | Inch | Size | mm | mm | mm | mm |
| 14946-10-4 | 14948-10-4 | 6 | 1/4 | -4 | 6.4 | 47 | 24 | 10 |
| 14946-12-4 | 14948-12-4 | 6 | 1/4 | -4 | 6.4 | 50 | 26 | 12 |
| 14946-14-4 | 14948-14-4 | 6 | 1/4 | -4 | 6.4 | 51 | 28 | 14 |
| | 14948-16-4 | 6 | 1/4 | -4 | 6.4 | 55.6 | 29 | 16.1 |
| 14946-14-5 | 14948-14-5 | 8 | 5/16 | -5 | 7.9 | 51 | 28 | 14 |
| 14946-16-5 | 14948-16-5 | 8 | 5/16 | -5 | 7.9 | 53 | 30 | 16 |
| 14946-16-6 | 14948-16-6 | 10 | 3/8 | -6 | 9.5 | 53 | 30 | 16 |
| 14946-17-6 | 14948-17-6 | 10 | 3/8 | -6 | 9.5 | 53 | 30 | 17 |
| 14946-18-6 | 14948-18-6 | 10 | 3/8 | -6 | 9.5 | 55 | 32 | 18 |
| 14946-22-6 | 14948-22-6 | 10 | 3/8 | -6 | 9.5 | 58 | 35 | 22 |
| 14946-18-8 | 14948-18-8 | 12 | 1/2 | -8 | 12.7 | 56 | 32 | 18 |
| 14946-22-8 | 14948-22-8 | 12 | 1/2 | -8 | 12.7 | 59 | 35 | 22 |
| 14946-22-10 | 14948-22-10 | 16 | 5/8 | -10 | 15.9 | 60 | 35 | 22 |
| 14946-26-12 | 14948-26-12 | 19 | 3/4 | -12 | 19.1 | 66 | 40 | 26 |
| 14946-27-12 | 14948-27-12 | 19 | 3/4 | -12 | 19.1 | 66 | 40 | 27 |

To select corresponding screw and seals see section Eb.

46/48 Series

Approved **fitting series** for hose types, depending on size: Also available in stainless steel. Details can be found in CAT 4400.1/UK

46 or **48** 441 | 461LT | 462 | 462TC | 462ST | 629PU | 692PU Twin

46 463 | 492 | 492ST | 492TC | 692 | 692Twin | 692TC | BCH1

48 301SN | 304 | 387 | 387ST | 387TC | 421RH | 421SN | 426 | 421TC | 436 | 441RH | 462PU | 462PU Twin | BCH2 | HT2 | ...

471TC | 477 | 477ST | 477TC | 477RH | 487 | 487ST | 487TC | 493 | 787 | 787TC | 787ST | 797 | 797TC | 797ST | 811 | 881



Cc-9

Catalogue 4400/UK

92 Female BSP Parallel Pipe Swivel – Straight (60° Cone)

BS5200-A – DKR

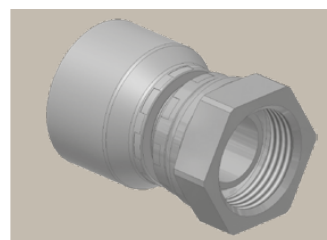
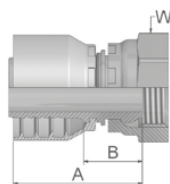

| Part Number | | Hose I.D. | | | | Thread | A | B | W |
|-------------|-------------|-----------|-------|------|------|----------|----|----|----|
| 46 series | 48 series | DN | Inch | Size | mm | BSP | mm | mm | mm |
| 19246-2-4 | 19248-2-4 | 6 | 1/4 | -4 | 6.4 | 1/8x28 | 41 | 17 | 14 |
| 19246-4-4 | | 6 | 1/4 | -4 | 6.4 | 1/4x19 | 46 | 19 | 19 |
| | 19248-4-4 | 6 | 1/4 | -4 | 6.4 | 1/4x19 | 43 | 19 | 19 |
| 19246-6-4 | 19248-6-4 | 6 | 1/4 | -4 | 6.4 | 3/8x19 | 44 | 20 | 22 |
| 19246-8-4 | 19248-8-4 | 6 | 1/4 | -4 | 6.4 | 1/2x14 | 49 | 25 | 27 |
| 19246-4-5 | 19248-4-5 | 8 | 5/16 | -5 | 7.9 | 1/4x19 | 43 | 19 | 19 |
| 19246-6-5 | 19248-6-5 | 8 | 5/16 | -5 | 7.9 | 3/8x19 | 44 | 20 | 22 |
| 19246-4-6 | 19248-4-6 | 10 | 3/8 | -6 | 9.5 | 1/4x19 | 43 | 20 | 19 |
| 19246-6-6 | 19248-6-6 | 10 | 3/8 | -6 | 9.5 | 3/8x19 | 43 | 20 | 22 |
| 19246-8-6 | 19248-8-6 | 10 | 3/8 | -6 | 9.5 | 1/2x14 | 45 | 22 | 27 |
| 19246-6-8 | 19248-6-8 | 12 | 1/2 | -8 | 12.7 | 3/8x19 | 45 | 21 | 22 |
| 19246-8-8 | 19248-8-8 | 12 | 1/2 | -8 | 12.7 | 1/2x14 | 45 | 22 | 27 |
| 19246-10-8 | 19248-10-8 | 12 | 1/2 | -8 | 12.7 | 5/8x14 | 44 | 20 | 30 |
| 19246-12-8 | 19248-12-8 | 12 | 1/2 | -8 | 12.7 | 3/4x14 | 47 | 23 | 32 |
| 19246-8-10 | 19248-8-10 | 16 | 5/8 | -10 | 15.9 | 1/2x14 | 48 | 22 | 27 |
| 19246-10-10 | 19248-10-10 | 16 | 5/8 | -10 | 15.9 | 5/8x14 | 45 | 20 | 30 |
| 19246-12-10 | 19248-12-10 | 16 | 5/8 | -10 | 15.9 | 3/4x14 | 47 | 22 | 32 |
| 19246-8-12 | 19248-8-12 | 19 | 3/4 | -12 | 19.1 | 1/2x14 | 49 | 23 | 27 |
| 19246-10-12 | 19248-10-12 | 19 | 3/4 | -12 | 19.1 | 5/8x14 | 47 | 22 | 30 |
| 19246-12-12 | 19248-12-12 | 19 | 3/4 | -12 | 19.1 | 3/4x14 | 49 | 23 | 32 |
| 19246-16-12 | 19248-16-12 | 19 | 3/4 | -12 | 19.1 | 1x11 | 51 | 25 | 41 |
| 19246-16-16 | 19248-16-16 | 25 | 1 | -16 | 25.4 | 1x11 | 55 | 25 | 41 |
| | 19248-20-16 | 25 | 1 | -16 | 25.4 | 1 1/4x11 | 63 | 31 | 50 |
| 19246-20-20 | | 31 | 1 1/4 | -20 | 31.8 | 1 1/4x11 | 68 | 31 | 50 |
| | 19248-20-20 | 31 | 1 1/4 | -20 | 31.8 | 1 1/4x11 | 79 | 32 | 50 |
| | 19248-24-24 | 38 | 1 1/2 | -24 | 38.1 | 1 1/2x11 | 71 | 33 | 60 |
| | 19248-32-32 | 51 | 2 | -32 | 50.8 | 2x11 | 84 | 35 | 70 |

Approved **fitting series** for hose types, depending on size: Also available in stainless steel. Details can be found in CAT 4400.1/UK

46 or **48** 441 461LT 462 462TC 462ST 629PU 692PU Twin

46 463 492 492ST 492TC 692 692Twin 692TC BCH1

48 301SN 304 387 387ST 387TC 421RH 421SN 426 421TC 436 441RH 462PU 462PU Twin BCH2 HT2 ...

471TC 477 477ST 477TC 477RH 487 487ST 487TC 493 787 787TC 787ST 797 797TC 797ST 811 881



Cc-10

Catalogue 4400/UK

B1 Female BSP Parallel Pipe Swivel 45° Elbow (60° Cone)

BS 5200-D – DKR 45°

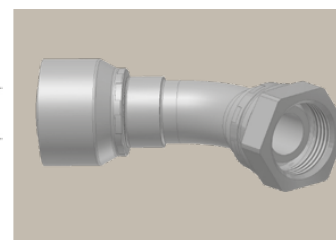
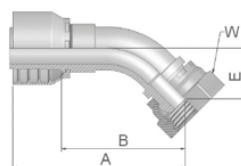

| Part Number | | Hose I.D. | | | | Thread | A | B | E | W |
|-------------|-------------|-----------|-------|------|------|----------|-----|-----|----|----|
| 46 series | 48 series | DN | Inch | Size | mm | BSP | mm | mm | mm | mm |
| 1B146-4-4 | | 6 | 1/4 | -4 | 6.4 | 1/4x19 | 59 | 35 | 16 | 19 |
| | 1B148-4-4 | 6 | 1/4 | -4 | 6.4 | 1/4x19 | 58 | 35 | 16 | 19 |
| 1B146-6-4 | 1B148-6-4 | 6 | 1/4 | -4 | 6.4 | 3/8x19 | 59 | 35 | 14 | 22 |
| 1B146-6-5 | 1B148-6-5 | 8 | 5/16 | -5 | 7.9 | 3/8x19 | 60 | 36 | 15 | 22 |
| 1B146-6-6 | 1B148-6-6 | 10 | 3/8 | -6 | 9.5 | 3/8x19 | 69 | 46 | 17 | 22 |
| 1B146-8-6 | 1B148-8-6 | 10 | 3/8 | -6 | 9.5 | 1/2x14 | 63 | 40 | 17 | 27 |
| 1B146-6-8 | 1B148-6-8 | 12 | 1/2 | -8 | 12.7 | 3/8x19 | 72 | 49 | 21 | 22 |
| 1B146-8-8 | 1B148-8-8 | 12 | 1/2 | -8 | 12.7 | 1/2x14 | 72 | 49 | 20 | 27 |
| 1B146-10-8 | 1B148-10-8 | 12 | 1/2 | -8 | 12.7 | 5/8x14 | 69 | 46 | 19 | 30 |
| 1B146-10-10 | 1B148-10-10 | 16 | 5/8 | -10 | 15.9 | 5/8x14 | 77 | 52 | 22 | 30 |
| 1B146-12-10 | 1B148-12-10 | 16 | 5/8 | -10 | 15.9 | 3/4x14 | 74 | 49 | 20 | 32 |
| 1B146-12-12 | 1B148-12-12 | 19 | 3/4 | -12 | 19.1 | 3/4x14 | 87 | 61 | 25 | 32 |
| 1B146-16-12 | 1B148-16-12 | 19 | 3/4 | -12 | 19.1 | 1x11 | 88 | 62 | 26 | 41 |
| 1B146-16-16 | 1B148-16-16 | 25 | 1 | -16 | 25.4 | 1x11 | 107 | 78 | 33 | 41 |
| 1B146-20-20 | | 31 | 1 1/4 | -20 | 31.8 | 1 1/4x11 | 136 | 98 | 38 | 50 |
| | 1B148-20-20 | 31 | 1 1/4 | -20 | 31.8 | 1 1/4x11 | 141 | 94 | 38 | 50 |
| | 1B148-24-24 | 38 | 1 1/2 | -24 | 38.1 | 1 1/2x11 | 160 | 122 | 52 | 55 |
| | 1B148-32-32 | 51 | 2 | -32 | 50.8 | 2x11 | 210 | 161 | 66 | 70 |

46/48 Series

Approved **fitting series** for hose types, depending on size: Also available in stainless steel. Details can be found in CAT 4400.1/UK

46 or **48** 441 461LT 462 462TC 462ST 629PU 692PU Twin

46 463 492 492ST 492TC 692 692Twin 692TC BCH1

48 301SN 304 387 387ST 387TC 421RH 421SN 426 421TC 436 441RH 462PU 462PU Twin BCH2 HT2 ...

471TC 477 477ST 477TC 477RH 487 487ST 487TC 493 787 787TC 787ST 797 797TC 797ST 811 881



B2 Female BSP Parallel Pipe Swivel 90° Elbow (60° Cone)

BS 5200-B – DKR 90°

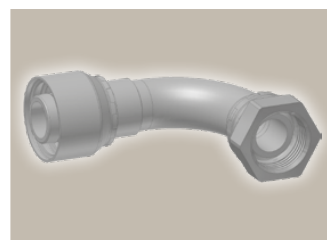
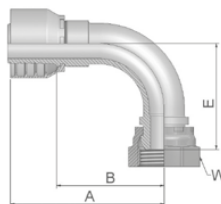

| Part Number | | Hose I.D. | | | | Thread | A | B | E | W |
|-------------|-------------|-----------|-------|------|------|----------|-----|-----|-----|----|
| 46 series | 48 series | DN | Inch | Size | mm | BSP | mm | mm | mm | mm |
| 1B246-2-4 | 1B248-2-4 | 6 | 1/4 | -4 | 6.4 | 1/8x28 | 50 | 26 | 30 | 14 |
| 1B246-4-4 | 1B248-4-4 | 6 | 1/4 | -4 | 6.4 | 1/4x19 | 50 | 26 | 28 | 19 |
| 1B246-6-4 | | 6 | 1/4 | -4 | 6.4 | 3/8x19 | 51 | 27 | 28 | 22 |
| | 1B248-6-4 | 6 | 1/4 | -4 | 6.4 | 3/8x19 | 51 | 27 | 27 | 22 |
| 1B246-8-4 | 1B248-8-4 | 6 | 1/4 | -4 | 6.4 | 1/2x14 | 51 | 27 | 29 | 27 |
| 1B246-6-5 | 1B248-6-5 | 8 | 5/16 | -5 | 7.9 | 3/8x19 | 52 | 28 | 28 | 22 |
| 1B246-6-6 | 1B248-6-6 | 10 | 3/8 | -6 | 9.5 | 3/8x19 | 61 | 38 | 33 | 22 |
| 1B246-8-6 | 1B248-8-6 | 10 | 3/8 | -6 | 9.5 | 1/2x14 | 60 | 38 | 36 | 27 |
| 1B246-6-8 | 1B248-6-8 | 12 | 1/2 | -8 | 12.7 | 3/8x19 | 63 | 40 | 41 | 22 |
| 1B246-8-8 | 1B248-8-8 | 12 | 1/2 | -8 | 12.7 | 1/2x14 | 63 | 40 | 41 | 27 |
| 1B246-10-8 | 1B248-10-8 | 12 | 1/2 | -8 | 12.7 | 5/8x14 | 67 | 43 | 38 | 30 |
| 1B246-10-10 | 1B248-10-10 | 16 | 5/8 | -10 | 15.9 | 5/8x14 | 70 | 45 | 44 | 30 |
| 1B246-12-10 | 1B248-12-10 | 16 | 5/8 | -10 | 15.9 | 3/4x14 | 70 | 45 | 42 | 32 |
| 1B246-12-12 | 1B248-12-12 | 19 | 3/4 | -12 | 19.1 | 3/4x14 | 80 | 54 | 53 | 32 |
| 1B246-16-12 | 1B248-16-12 | 19 | 3/4 | -12 | 19.1 | 1x11 | 80 | 54 | 54 | 41 |
| 1B246-16-16 | 1B248-16-16 | 25 | 1 | -16 | 25.4 | 1x11 | 104 | 75 | 69 | 41 |
| 1B246-20-20 | | 31 | 1 1/4 | -20 | 31.8 | 1 1/4x11 | 124 | 86 | 80 | 50 |
| | 1B248-20-20 | 31 | 1 1/4 | -20 | 31.8 | 1 1/4x11 | 129 | 82 | 80 | 50 |
| | 1B248-24-24 | 38 | 1 1/2 | -24 | 38.1 | 1 1/2x11 | 140 | 102 | 103 | 55 |
| | 1B248-32-32 | 51 | 2 | -32 | 50.8 | 2x11 | 185 | 137 | 134 | 70 |

Approved **fitting series** for hose types, depending on size: Also available in stainless steel. Details can be found in CAT 4400.1/UK

46 or **48** 441 | 461LT | 462 | 462TC | 462ST | 629PU | 692PU Twin

46 463 | 492 | 492ST | 492TC | 692 | 692Twin | 692TC | BCH1

48 301SN | 304 | 387 | 387ST | 387TC | 421RH | 421SN | 426 | 421TC | 436 | 441RH | 462PU | 462PU Twin | BCH2 | HT2 | ...

471TC | 477 | 477ST | 477TC | 477RH | 487 | 487ST | 487TC | 493 | 787 | 787TC | 787ST | 797 | 797TC | 797ST | 811 | 881



B4 Female BSP Parallel Pipe Swivel – 90° Elbow Block Type (60° Cone)

BS 5200-E – DKR 90°

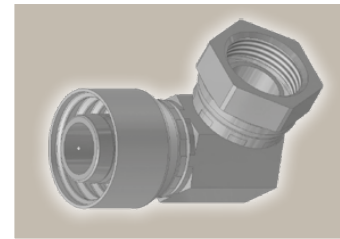
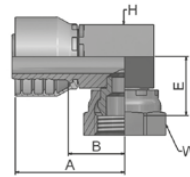

| Part Number | | Hose I.D. | | | | Thread | A | B | E | H | W |
|-------------|-------------|-----------|------|------|------|--------|----|----|----|----|----|
| 46 series | 48 series | DN | Inch | Size | mm | BSP | mm | mm | mm | mm | mm |
| 1B446-4-4 | 1B448-4-4 | 6 | 1/4 | -4 | 6.4 | 1/4x19 | 58 | 34 | 22 | 17 | 19 |
| 1B446-6-4 | 1B448-6-4 | 6 | 1/4 | -4 | 6.4 | 3/8x19 | 43 | 20 | 22 | 17 | 22 |
| 1B446-6-6 | 1B448-6-6 | 10 | 3/8 | -6 | 9.5 | 3/8x19 | 68 | 45 | 23 | 19 | 22 |
| 1B446-8-6 | 1B448-8-6 | 10 | 3/8 | -6 | 9.5 | 1/2x14 | 67 | 44 | 27 | 22 | 27 |
| 1B446-8-8 | 1B448-8-8 | 12 | 1/2 | -8 | 12.7 | 1/2x14 | 67 | 43 | 27 | 22 | 27 |
| 1B446-10-10 | 1B448-10-10 | 16 | 5/8 | -10 | 15.9 | 5/8x14 | 69 | 44 | 27 | 27 | 30 |
| 1B446-12-12 | 1B448-12-12 | 19 | 3/4 | -12 | 19.1 | 3/4x14 | 72 | 47 | 33 | 32 | 32 |
| 1B446-16-16 | 1B448-16-16 | 25 | 1 | -16 | 25.4 | 1x11 | 82 | 52 | 34 | 36 | 41 |

Short version available upon request (swaging on universal crimpers only)

Approved **fitting series** for hose types, depending on size: Also available in stainless steel. Details can be found in CAT 4400.1/UK

46 or **48** 441 461LT 462 462TC 462ST 629PU 692PU Twin

46 463 492 492ST 492TC 692 692Twin 692TC BCH1

48 301SN 304 387 387ST 387TC 421RH 421SN 426 421TC 436 441RH 462PU 462PU Twin BCH2 HT2 ...

471TC 477 477ST 477TC 477RH 487 487ST 487TC 493 787 787TC 787ST 797 797TC 797ST 811 881

EA **BSP Swivel Female
with O-Ring (60° Cone)**
BS 5200 – ISO 12151-6 – DKOR

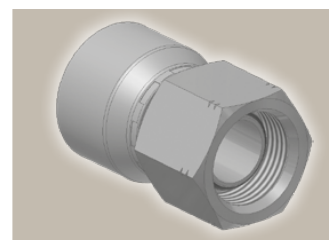
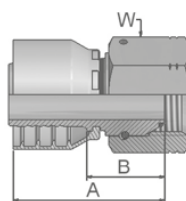

| Part Number | | Hose I.D. | | | | Thread | A | B | W |
|-------------|-------------|-----------|-------|------|------|----------|----|----|----|
| 46 series | 48 series | DN | Inch | Size | mm | BSP | mm | mm | mm |
| 1EA46-4-4 | 1EA48-4-4 | 6 | 1/4 | -4 | 6.4 | 1/4x19 | 40 | 17 | 19 |
| 1EA46-6-4 | 1EA48-6-4 | 6 | 1/4 | -4 | 6.4 | 3/8x19 | 49 | 26 | 22 |
| | 1EA48-6-5 | 8 | 5/16 | -5 | 7.9 | 3/8x19 | 50 | 25 | 22 |
| | 1EA48-4-6 | 10 | 3/8 | -6 | 9.5 | 1/4x19 | 44 | 21 | 19 |
| 1EA46-6-6 | 1EA48-6-6 | 10 | 3/8 | -6 | 9.5 | 3/8x19 | 43 | 20 | 22 |
| 1EA46-8-6 | 1EA48-8-6 | 10 | 3/8 | -6 | 9.5 | 1/2x14 | 51 | 28 | 27 |
| | 1EA48-6-8 | 12 | 1/2 | -8 | 12.7 | 3/8x19 | 46 | 22 | 22 |
| 1EA46-8-8 | 1EA48-8-8 | 12 | 1/2 | -8 | 12.7 | 1/2x14 | 45 | 22 | 27 |
| | 1EA48-10-8 | 12 | 1/2 | -8 | 12.7 | 5/8x14 | 43 | 20 | 30 |
| 1EA46-10-10 | 1EA48-10-10 | 16 | 5/8 | -10 | 15.9 | 5/8x14 | 46 | 21 | 30 |
| 1EA46-12-10 | 1EA48-12-10 | 16 | 5/8 | -10 | 15.9 | 3/4x14 | 54 | 29 | 32 |
| 1EA46-12-12 | 1EA48-12-12 | 19 | 3/4 | -12 | 19.1 | 3/4x14 | 49 | 23 | 32 |
| 1EA46-16-12 | 1EA48-16-12 | 19 | 3/4 | -12 | 19.1 | 1x11 | 61 | 35 | 41 |
| 1EA46-16-16 | 1EA48-16-16 | 25 | 1 | -16 | 25.4 | 1x11 | 61 | 31 | 41 |
| | 1EA48-20-20 | 31 | 1 1/4 | -20 | 31.8 | 1 1/4x11 | 78 | 31 | 50 |
| | 1EA48-24-24 | 38 | 1 1/2 | -24 | 38.1 | 1 1/2x11 | 72 | 34 | 55 |

Hose fittings are delivered with ozone resistant Nitrile (NBR) O-ring as a standard version. Working temperature from -40 °C up to +105 °C.
Hose fittings with special O-rings (Viton or EPDM) available on request. O-ring dimensions and part-numbers see in section Eb.

Approved **fitting series** for hose types, depending on size: Also available in stainless steel. Details can be found in CAT 4400.1/UK

46 or **48** 441 | 461LT | 462 | 462TC | 462ST | 629PU | 692PU Twin

46 463 | 492 | 492ST | 492TC | 692 | 692Twin | 692TC | BCH1

48 301SN | 304 | 387 | 387ST | 387TC | 421RH | 421SN | 426 | 421TC | 436 | 441RH | 462PU | 462PU Twin | BCH2 | HT2 | ...

471TC | 477 | 477ST | 477TC | 477RH | 487 | 487ST | 487TC | 493 | 787 | 787TC | 787ST | 797 | 797TC | 797ST | 811 | 881

EB **BSP Swivel Female
with O-Ring
45° Elbow (60° Cone)**

BS 5200 – ISO 12151-6 – DKOR 45°

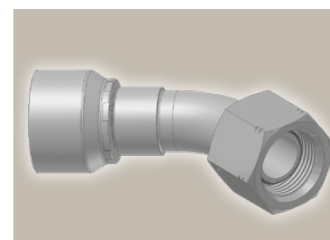
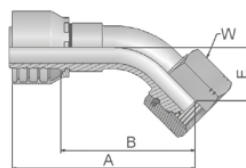

| Part Number | | Hose I.D. | | | | Thread | A | B | E | W |
|-------------|-------------|-----------|-------|------|------|----------|-----|-----|----|----|
| 46 series | 48 series | DN | Inch | Size | mm | BSP | mm | mm | mm | mm |
| 1EB46-4-4 | | 6 | 1/4 | -4 | 6.4 | 1/4x19 | 59 | 36 | 14 | 19 |
| | 1EB48-4-4 | 6 | 1/4 | -4 | 6.4 | 1/4x19 | 57 | 34 | 14 | 19 |
| 1EB46-6-6 | 1EB48-6-6 | 10 | 3/8 | -6 | 9.5 | 3/8x19 | 69 | 46 | 17 | 22 |
| 1EB46-8-8 | 1EB48-8-8 | 12 | 1/2 | -8 | 12.7 | 1/2x14 | 71 | 48 | 20 | 27 |
| 1EB46-12-10 | 1EB48-12-10 | 16 | 5/8 | -10 | 15.9 | 3/4x14 | 78 | 52 | 21 | 32 |
| 1EB46-12-12 | 1EB48-12-12 | 19 | 3/4 | -12 | 19.1 | 3/4x14 | 89 | 63 | 27 | 32 |
| 1EB46-16-16 | 1EB48-16-16 | 25 | 1 | -16 | 25.4 | 1x11 | 112 | 82 | 33 | 41 |
| | 1EB48-20-20 | 31 | 1 1/4 | -20 | 31.8 | 1 1/4x11 | 138 | 91 | 35 | 50 |
| | 1EB48-24-24 | 38 | 1 1/2 | -24 | 38.1 | 1 1/2x11 | 157 | 119 | 50 | 55 |

Hose fittings are delivered with ozone resistant Nitrile (NBR) O-ring as a standard version. Working temperature from -40 °C up to +105 °C.
Hose fittings with special O-rings (Viton or EPDM) available on request. O-ring dimensions and part-numbers see in section Eb.

46/48 Series

Approved **fitting series** for hose types, depending on size: Also available in stainless steel. Details can be found in CAT 4400.1/UK

46 or **48** 441 461LT 462 462TC 462ST 629PU 692PU Twin

46 463 492 492ST 492TC 692 692Twin 692TC BCH1

48 301SN 304 387 387ST 387TC 421RH 421SN 426 421TC 436 441RH 462PU 462PU Twin BCH2 HT2 ...

471TC 477 477ST 477TC 477RH 487 487ST 487TC 493 787 787TC 787ST 797 797TC 797ST 811 881

EC BSP Swivel Female with O-Ring 90° Elbow (60° Cone)

BS 5200 – ISO 12151-6 – DKOR 90°

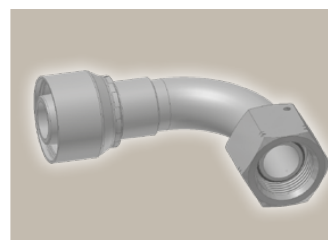
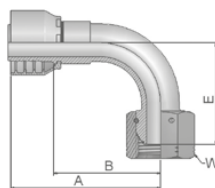

| Part Number | | Hose I.D. | | | | Thread | A | B | E | W |
|-------------|-------------|-----------|-------|------|------|----------|-----|-----|-----|----|
| 46 series | 48 series | DN | Inch | Size | mm | BSP | mm | mm | mm | mm |
| 1EC46-4-4 | 1EC48-4-4 | 6 | 1/4 | -4 | 6.4 | 1/4x19 | 50 | 27 | 24 | 19 |
| 1EC46-6-4 | 1EC48-6-4 | 6 | 1/4 | -4 | 6.4 | 3/8x19 | 51 | 28 | 27 | 22 |
| 1EC46-6-6 | 1EC48-6-6 | 10 | 3/8 | -6 | 9.5 | 3/8x19 | 60 | 38 | 33 | 22 |
| 1EC46-8-6 | 1EC48-8-6 | 10 | 3/8 | -6 | 9.5 | 1/2x14 | 60 | 38 | 36 | 27 |
| | 1EC48-6-8 | 12 | 1/2 | -8 | 12.7 | 3/8x19 | 63 | 39 | 41 | 22 |
| 1EC46-8-8 | 1EC48-8-8 | 12 | 1/2 | -8 | 12.7 | 1/2x14 | 63 | 40 | 40 | 27 |
| 1EC46-10-8 | 1EC48-10-8 | 12 | 1/2 | -8 | 12.7 | 5/8x14 | 63 | 40 | 39 | 30 |
| 1EC46-10-10 | 1EC48-10-10 | 16 | 5/8 | -10 | 15.9 | 5/8x14 | 70 | 45 | 44 | 30 |
| 1EC46-12-10 | | 16 | 5/8 | -10 | 15.9 | 3/4x14 | 70 | 45 | 42 | 32 |
| | 1EC48-12-10 | 16 | 5/8 | -10 | 15.9 | 5/8x14 | 70 | 45 | 42 | 32 |
| 1EC46-12-12 | 1EC48-12-12 | 19 | 3/4 | -12 | 19.1 | 3/4x14 | 79 | 54 | 55 | 32 |
| 1EC46-16-12 | 1EC48-16-12 | 19 | 3/4 | -12 | 19.1 | 1x11 | 80 | 54 | 59 | 41 |
| 1EC46-16-16 | 1EC48-16-16 | 25 | 1 | -16 | 25.4 | 1x11 | 105 | 75 | 71 | 41 |
| | 1EC48-20-20 | 31 | 1 1/4 | -20 | 31.8 | 1 1/4x11 | 129 | 82 | 75 | 50 |
| | 1EC48-24-24 | 38 | 1 1/2 | -24 | 38.1 | 1 1/2x11 | 140 | 102 | 103 | 55 |
| | 1EC48-32-32 | 51 | 2 | -32 | 50.8 | 2x11 | 185 | 137 | 132 | 70 |

Hose fittings are delivered with ozone resistant Nitrile (NBR) O-ring as a standard version. Working temperature from -40 °C up to +105 °C. Hose fittings with special O-rings (Viton or EPDM) available on request. O-ring dimensions and part-numbers see in section Eb.

Approved **fitting series** for hose types, depending on size: Also available in stainless steel. Details can be found in CAT 4400.1/UK

46 or **48** 441 | 461LT | 462 | 462TC | 462ST | 629PU | 692PU Twin

46 463 | 492 | 492ST | 492TC | 692 | 692Twin | 692TC | BCH1

48 301SN | 304 | 387 | 387ST | 387TC | 421RH | 421SN | 426 | 421TC | 436 | 441RH | 462PU | 462PU Twin | BCH2 | HT2 | ...

471TC | 477 | 477ST | 477TC | 477RH | 487 | 487ST | 487TC | 493 | 787 | 787TC | 787ST | 797 | 797TC | 797ST | 811 | 881

D9 **Male BSP Parallel Pipe**
Rigid – Straight (60° Cone)
BS5200 – AGR

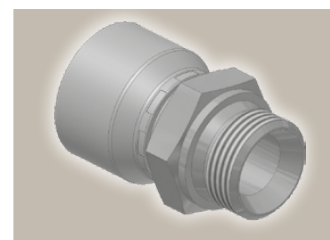
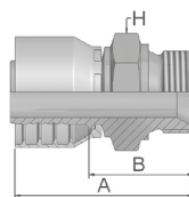

| Part Number | | Hose I.D. | | | | Thread | A | B | H |
|-------------|-------------|-----------|-------|------|------|----------|-----|----|----|
| 46 series | 48 series | DN | Inch | Size | mm | BSP | mm | mm | mm |
| 1D946-2-4 | 1D948-2-4 | 6 | 1/4 | -4 | 6.4 | 1/8x28 | 46 | 22 | 14 |
| 1D946-4-4 | 1D948-4-4 | 6 | 1/4 | -4 | 6.4 | 1/4x19 | 51 | 27 | 19 |
| 1D946-6-4 | 1D948-6-4 | 6 | 1/4 | -4 | 6.4 | 3/8x19 | 53 | 31 | 22 |
| 1D946-8-4 | 1D948-8-4 | 6 | 1/4 | -4 | 6.4 | 1/2x14 | 54 | 52 | 27 |
| 1D946-4-5 | | 8 | 5/16 | -5 | 7.9 | 1/4x19 | 50 | 27 | 19 |
| | 1D948-4-5 | 8 | 5/16 | -5 | 7.9 | 1/4x19 | 49 | 27 | 19 |
| 1D946-6-5 | 1D948-6-5 | 8 | 5/16 | -5 | 7.9 | 3/8x19 | 55 | 31 | 22 |
| 1D946-4-6 | | 10 | 3/8 | -6 | 9.5 | 1/4x19 | 49 | 27 | 19 |
| | 1D948-4-6 | 10 | 3/8 | -6 | 9.5 | 1/4x19 | 50 | 27 | 19 |
| 1D946-6-6 | 1D948-6-6 | 10 | 3/8 | -6 | 9.5 | 3/8x19 | 54 | 31 | 22 |
| 1D946-8-6 | 1D948-8-6 | 10 | 3/8 | -6 | 9.5 | 1/2x14 | 56 | 33 | 27 |
| 1D946-6-8 | 1D948-6-8 | 12 | 1/2 | -8 | 12.7 | 3/8x19 | 54 | 30 | 22 |
| 1D946-8-8 | 1D948-8-8 | 12 | 1/2 | -8 | 12.7 | 1/2x14 | 57 | 33 | 27 |
| 1D946-10-8 | 1D948-10-8 | 12 | 1/2 | -8 | 12.7 | 5/8x14 | 58 | 35 | 30 |
| 1D946-12-8 | 1D948-12-8 | 12 | 1/2 | -8 | 12.7 | 3/4x14 | 60 | 36 | 32 |
| 1D946-8-10 | 1D948-8-10 | 16 | 5/8 | -10 | 15.9 | 1/2x14 | 58 | 33 | 27 |
| 1D946-10-10 | 1D948-10-10 | 16 | 5/8 | -10 | 15.9 | 5/8x14 | 60 | 35 | 30 |
| 1D946-12-10 | 1D948-12-10 | 16 | 5/8 | -10 | 15.9 | 3/4x14 | 62 | 37 | 32 |
| 1D946-12-12 | 1D948-12-12 | 19 | 3/4 | -12 | 19.1 | 3/4x14 | 62 | 36 | 32 |
| 1D946-16-12 | 1D948-16-12 | 19 | 3/4 | -12 | 19.1 | 1x11 | 67 | 41 | 41 |
| 1D946-16-16 | 1D948-16-16 | 25 | 1 | -16 | 25.4 | 1x11 | 72 | 42 | 41 |
| | 1D948-20-16 | 25 | 1 | -16 | 25.4 | 1 1/4x11 | 75 | 46 | 50 |
| 1D946-20-20 | | 31 | 1 1/4 | -20 | 31.8 | 1 1/4x11 | 85 | 47 | 50 |
| | 1D948-20-20 | 31 | 1 1/4 | -20 | 31.8 | 1 1/4x11 | 92 | 45 | 50 |
| | 1D948-24-24 | 38 | 1 1/2 | -24 | 38.1 | 1 1/2x11 | 87 | 49 | 60 |
| | 1D948-32-32 | 51 | 2 | -32 | 50.8 | 2x11 | 102 | 54 | 70 |

46/48 Series

Approved **fitting series** for hose types, depending on size: Also available in stainless steel. Details can be found in CAT 4400.1/UK

46 or **48** 441 461LT 462 462TC 462ST 629PU 692PU Twin

46 463 492 492ST 492TC 692 692Twin 692TC BCH1

48 301SN 304 387 387ST 387TC 421RH 421SN 426 421TC 436 441RH 462PU 462PU Twin BCH2 HT2 ...

471TC 477 477ST 477TC 477RH 487 487ST 487TC 493 787 787TC 787ST 797 797TC 797ST 811 881



91 Male BSP Taper Pipe – Rigid Straight

BS5200 – AGR-K

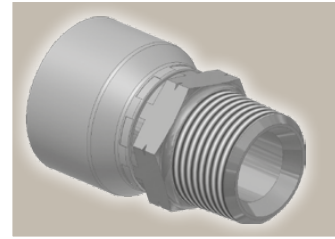
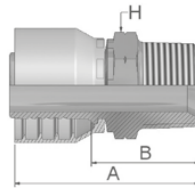

| Part Number | | Hose I.D. | | | | Thread | A | B | H |
|-------------|-------------|-----------|------|------|------|--------|----|----|----|
| 46 series | 48 series | DN | Inch | Size | mm | BSP | mm | mm | mm |
| 19146-4-4 | 19148-4-4 | 6 | 1/4 | -4 | 6.4 | 1/4x19 | 49 | 26 | 14 |
| | 19148-6-4 | 6 | 1/4 | -4 | 6.4 | 3/8x19 | 51 | 28 | 17 |
| 19146-4-5 | 19148-4-5 | 8 | 5/16 | -5 | 7.9 | 1/4x19 | 49 | 25 | 14 |
| 19146-6-5 | 19148-6-5 | 8 | 5/16 | -5 | 7.9 | 3/8x19 | 48 | 24 | 19 |
| | 19148-4-6 | 10 | 3/8 | -6 | 9.5 | 1/4x19 | 46 | 24 | 14 |
| 19146-6-6 | 19148-6-6 | 10 | 3/8 | -6 | 9.5 | 3/8x19 | 52 | 27 | 19 |
| 19146-8-6 | 19148-8-6 | 10 | 3/8 | -6 | 9.5 | 1/2x14 | 57 | 34 | 22 |
| | 19148-6-8 | 12 | 1/2 | -8 | 12.7 | 3/8x19 | 48 | 25 | 19 |
| 19146-8-8 | 19148-8-8 | 12 | 1/2 | -8 | 12.7 | 1/2x14 | 57 | 33 | 22 |
| | 19148-12-10 | 16 | 5/8 | -10 | 15.9 | 3/4x14 | 63 | 37 | 30 |
| 19146-12-12 | 19148-12-12 | 19 | 3/4 | -12 | 19.1 | 3/4x14 | 63 | 37 | 30 |
| 19146-16-16 | 19148-16-16 | 25 | 1 | -16 | 25.4 | 1x11 | 72 | 42 | 36 |

B5 Female BSP Parallel Pipe Swivel Straight (Flat Seat)

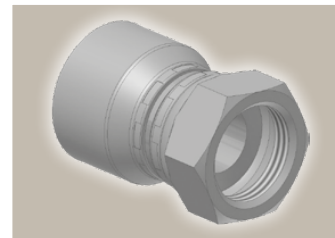
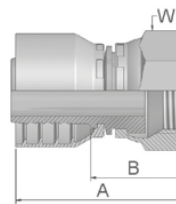

| Part Number | | Hose I.D. | | | | Thread | A | B | W |
|-------------|-------------|-----------|------|------|------|--------|----|----|----|
| 46 series | 48 series | DN | Inch | Size | mm | BSP | mm | mm | mm |
| 1B546-4-4 | 1B548-4-4 | 6 | 1/4 | -4 | 6.4 | 1/4x19 | 41 | 17 | 19 |
| 1B546-4-5 | 1B548-4-5 | 8 | 5/16 | -5 | 7.9 | 1/4x19 | 41 | 17 | 19 |
| 1B546-6-5 | 1B548-6-5 | 8 | 5/16 | -5 | 7.9 | 3/8x19 | 38 | 14 | 22 |
| 1B546-8-5 | 1B548-8-5 | 8 | 5/16 | -5 | 7.9 | 1/2x14 | 44 | 21 | 27 |
| 1B546-6-6 | 1B548-6-6 | 10 | 3/8 | -6 | 9.5 | 3/8x19 | 37 | 14 | 22 |
| 1B546-8-6 | 1B548-8-6 | 10 | 3/8 | -6 | 9.5 | 1/2x14 | 43 | 20 | 27 |
| 1B546-8-8 | 1B548-8-8 | 12 | 1/2 | -8 | 12.7 | 1/2x14 | 43 | 19 | 27 |
| 1B546-12-8 | 1B548-12-8 | 12 | 1/2 | -8 | 12.7 | 3/4x14 | 43 | 19 | 32 |
| 1B546-12-10 | 1B548-12-10 | 16 | 5/8 | -10 | 15.9 | 3/4x14 | 43 | 18 | 32 |
| 1B546-12-12 | 1B548-12-12 | 19 | 3/4 | -12 | 19.1 | 3/4x14 | 44 | 18 | 32 |
| 1B546-16-16 | 1B548-16-16 | 25 | 1 | -16 | 25.4 | 1x11 | 51 | 21 | 41 |

Approved **fitting series** for hose types, depending on size: Also available in stainless steel. Details can be found in CAT 4400.1/UK

| | | | | | | | | | | | | | | | | | |
|------------------------|-------|-------|-------|-------|-------|---------|------------|-------|-------|-----|-------|-------|------------|-------|-------|-----|-----|
| 46 or 48 | 441 | 461LT | 462 | 462TC | 462ST | 629PU | 692PU Twin | | | | | | | | | | |
| 46 | 463 | 492 | 492ST | 492TC | 692 | 692Twin | 692TC | BCH1 | | | | | | | | | |
| 48 | 301SN | 304 | 387 | 387ST | 387TC | 421RH | 421SN | 426 | 421TC | 436 | 441RH | 462PU | 462PU Twin | BCH2 | HT2 | ... | |
| | 471TC | 477 | 477ST | 477TC | 477RH | 487 | 487ST | 487TC | 493 | 787 | 787TC | 787ST | 797 | 797TC | 797ST | 811 | 881 |



01 **Male NPTF Pipe**
Rigid – Straight
SAE J476A / J516 – AGN

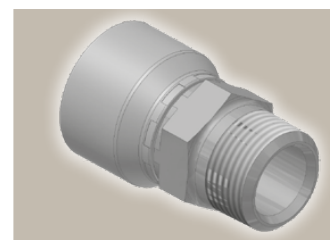
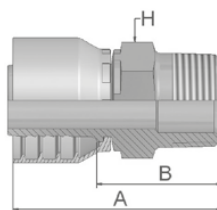

| Part Number | | Hose I.D. | | | | Thread | A | B | H |
|-------------|-------------|-----------|-------|------|------|--------------|-----|----|----|
| 46 series | 48 series | DN | Inch | Size | mm | NPTF | mm | mm | mm |
| 10146-2-4 | 10148-2-4 | 6 | 1/4 | -4 | 6.4 | 1/8-27 | 48 | 24 | 12 |
| 10146-4-4 | 10148-4-4 | 6 | 1/4 | -4 | 6.4 | 1/4-18 | 53 | 29 | 14 |
| 10146-6-4 | 10148-6-4 | 6 | 1/4 | -4 | 6.4 | 3/8-18 | 55 | 31 | 19 |
| 10146-4-5 | 10148-4-5 | 8 | 5/16 | -5 | 7.9 | 1/4-18 | 53 | 29 | 14 |
| 10146-6-5 | 10148-6-5 | 8 | 5/16 | -5 | 7.9 | 3/8-18 | 55 | 31 | 19 |
| 10146-4-6 | 10148-4-6 | 10 | 3/8 | -6 | 9.5 | 1/4-18 | 52 | 29 | 14 |
| 10146-6-6 | 10148-6-6 | 10 | 3/8 | -6 | 9.5 | 3/8-18 | 54 | 31 | 19 |
| 10146-8-6 | 10148-8-6 | 10 | 3/8 | -6 | 9.5 | 1/2-14 | 55 | 32 | 22 |
| 10146-6-8 | 10148-6-8 | 12 | 1/2 | -8 | 12.7 | 3/8-18 | 55 | 32 | 19 |
| 10146-8-8 | 10148-8-8 | 12 | 1/2 | -8 | 12.7 | 1/2-14 | 61 | 38 | 22 |
| 10146-8-10 | 10148-8-10 | 16 | 5/8 | -10 | 15.9 | 1/2-14 | 63 | 38 | 22 |
| 10146-12-10 | 10148-12-10 | 16 | 5/8 | -10 | 15.9 | 3/4-14 | 59 | 34 | 27 |
| 10146-12-12 | 10148-12-12 | 19 | 3/4 | -12 | 19.1 | 3/4-14 | 60 | 34 | 27 |
| 10146-16-16 | 10148-16-16 | 25 | 1 | -16 | 25.4 | 1-11 1/2 | 75 | 45 | 36 |
| 10146-20-20 | | 31 | 1 1/4 | -20 | 31.8 | 1 1/4-11 1/2 | 86 | 48 | 46 |
| | 10148-20-20 | 31 | 1 1/4 | -20 | 31.8 | 1 1/4-11 1/2 | 104 | 57 | 46 |
| | 10148-24-24 | 38 | 1 1/2 | -24 | 38.1 | 1 1/2-11 1/2 | 89 | 51 | 50 |
| | 10148-32-32 | 51 | 2 | -32 | 50.8 | 2-11 1/2 | 104 | 55 | 65 |

46/48 Series

Approved **fitting series** for hose types, depending on size: Also available in stainless steel. Details can be found in CAT 4400.1/UK

46 or **48** 441 461LT 462 462TC 462ST 629PU 692PU Twin

46 463 492 492ST 492TC 692 692Twin 692TC BCH1

48 301SN 304 387 387ST 387TC 421RH 421SN 426 421TC 436 441RH 462PU 462PU Twin BCH2 HT2 ...

471TC 477 477ST 477TC 477RH 487 487ST 487TC 493 787 787TC 787ST 797 797TC 797ST 811 881



03 Male JIC 37° - Rigid Straight

ISO12151-5-S - AGJ

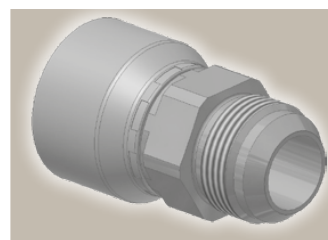
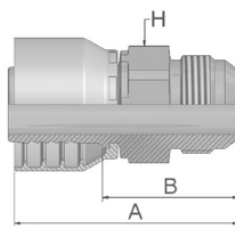

| Part Number | | Hose I.D. | | | | Thread | A | B | H |
|-------------|-------------|-----------|-------|------|------|-----------|-----|----|----|
| 46 series | 48 series | DN | Inch | Size | mm | UNF | mm | mm | mm |
| 10346-4-4 | 10348-4-4 | 6 | 1/4 | -4 | 6.4 | 7/16x20 | 52 | 29 | 14 |
| 10346-5-4 | 10348-5-4 | 6 | 1/4 | -4 | 6.4 | 1/2x20 | 52 | 29 | 14 |
| 10346-6-4 | 10348-6-4 | 6 | 1/4 | -4 | 6.4 | 9/16x18 | 55 | 31 | 19 |
| 10346-5-5 | 10348-5-5 | 8 | 5/16 | -5 | 7.9 | 1/2x20 | 50 | 26 | 14 |
| 10346-6-5 | 10348-6-5 | 8 | 5/16 | -5 | 7.9 | 9/16x18 | 55 | 31 | 19 |
| 10346-8-5 | 10348-8-5 | 8 | 5/16 | -5 | 7.9 | 3/4x16 | 57 | 33 | 19 |
| 10346-4-6 | 10348-4-6 | 10 | 3/8 | -6 | 9.5 | 7/16x20 | 54 | 31 | 19 |
| 10346-5-6 | 10348-5-6 | 10 | 3/8 | -6 | 9.5 | 1/2x20 | 53 | 30 | 19 |
| 10346-6-6 | 10348-6-6 | 10 | 3/8 | -6 | 9.5 | 9/16x18 | 56 | 31 | 19 |
| 10346-8-6 | 10348-8-6 | 10 | 3/8 | -6 | 9.5 | 3/4x16 | 53 | 30 | 22 |
| 10346-10-6 | 10348-10-6 | 10 | 3/8 | -6 | 9.5 | 7/8x14 | 56 | 33 | 24 |
| 10346-8-8 | 10348-8-8 | 12 | 1/2 | -8 | 12.7 | 3/4x16 | 57 | 34 | 22 |
| 10346-10-8 | 10348-10-8 | 12 | 1/2 | -8 | 12.7 | 7/8x14 | 56 | 32 | 24 |
| 10346-12-8 | 10348-12-8 | 12 | 1/2 | -8 | 12.7 | 1 1/16x12 | 62 | 38 | 27 |
| 10346-10-10 | 10348-10-10 | 16 | 5/8 | -10 | 15.9 | 7/8x14 | 63 | 38 | 24 |
| 10346-12-10 | 10348-12-10 | 16 | 5/8 | -10 | 15.9 | 1 1/16x12 | 64 | 39 | 27 |
| 10346-12-12 | 10348-12-12 | 19 | 3/4 | -12 | 19.1 | 1 1/16x12 | 68 | 42 | 27 |
| 10346-14-12 | 10348-14-12 | 19 | 3/4 | -12 | 19.1 | 1 3/16x12 | 68 | 42 | 30 |
| 10346-16-12 | 10348-16-12 | 19 | 3/4 | -12 | 19.1 | 1 5/16x12 | 64 | 38 | 36 |
| 10346-16-16 | 10348-16-16 | 25 | 1 | -16 | 25.4 | 1 5/16x12 | 76 | 46 | 36 |
| 10346-20-16 | 10348-20-16 | 25 | 1 | -16 | 25.4 | 1 5/8x12 | 73 | 43 | 46 |
| 10346-20-20 | | 31 | 1 1/4 | -20 | 31.8 | 1 5/8x12 | 86 | 48 | 46 |
| | 10348-20-20 | 31 | 1 1/4 | -20 | 31.8 | 1 5/8x12 | 101 | 53 | 46 |
| | 10348-24-24 | 38 | 1 1/2 | -24 | 38.1 | 1 7/8x12 | 85 | 47 | 50 |
| | 10348-32-32 | 51 | 2 | -32 | 50.8 | 2 1/2x12 | 109 | 61 | 65 |

Approved **fitting series** for hose types, depending on size: Also available in stainless steel. Details can be found in CAT 4400.1/UK

46 or **48** 441 461LT 462 462TC 462ST 629PU 692PU Twin

46 463 492 492ST 492TC 692 692Twin 692TC BCH1

48 301SN 304 387 387ST 387TC 421RH 421SN 426 421TC 436 441RH 462PU 462PU Twin BCH2 HT2 ...

471TC 477 477ST 477TC 477RH 487 487ST 487TC 493 787 787TC 787ST 797 797TC 797ST 811 881



Cc-20

Catalogue 4400/UK

Medium Pressure
SAE

Parkrimp No-Skive Fittings
46/48 Series

06/68 Female – JIC 37°
SAE 45° Dual Flare
Swivel – Straight
ISO12151-5-SWS – DKJ

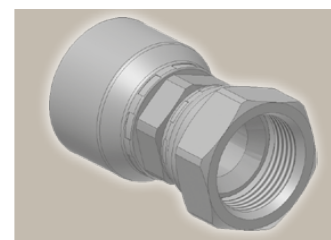
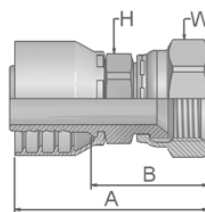

*New 3S-Fitting-Design – more information see Cc-Index

| Part Number | | Hose I.D. | | | | Thread | A | B | H | W |
|-------------|--------------|-----------|-------|------|------|-----------|-----|----|----|----|
| 46 series | 48 series | DN | Inch | Size | mm | UNF | mm | mm | mm | mm |
| 16846-4-4 | 10648-4-4* | 6 | 1/4 | -4 | 6.4 | 7/16x20 | 48 | 24 | 13 | 14 |
| 16846-5-4 | 10648-5-4* | 6 | 1/4 | -4 | 6.4 | 1/2x20 | 49 | 25 | 13 | 17 |
| 10646-6-4 | 10648-6-4* | 6 | 1/4 | -4 | 6.4 | 9/16x18 | 55 | 31 | 14 | 19 |
| 16846-5-5 | 16848-5-5 | 8 | 5/16 | -5 | 7.9 | 1/2x20 | 54 | 31 | 14 | 17 |
| 10646-6-5 | 10648-6-5 | 8 | 5/16 | -5 | 7.9 | 9/16x18 | 53 | 29 | 14 | 19 |
| 16846-8-5 | 16848-8-5 | 8 | 5/16 | -5 | 7.9 | 3/4x16 | 57 | 34 | 17 | 22 |
| 16846-4-6 | 16848-4-6 | 10 | 3/8 | -6 | 9.5 | 7/16x20 | 50 | 27 | 14 | 17 |
| 16846-5-6 | 16848-5-6 | 10 | 3/8 | -6 | 9.5 | 1/2x20 | 52 | 29 | 14 | 17 |
| 10646-6-6 | 10648-6-6* | 10 | 3/8 | -6 | 9.5 | 9/16x18 | 52 | 30 | 17 | 19 |
| 16846-8-6 | 10648-8-6* | 10 | 3/8 | -6 | 9.5 | 3/4x16 | 56 | 34 | 17 | 22 |
| 16846-10-6 | 16848-10-6 | 10 | 3/8 | -6 | 9.5 | 7/8x14 | 59 | 36 | 22 | 27 |
| 10646-6-8 | 10648-6-8 | 12 | 1/2 | -8 | 12.7 | 9/16x18 | 55 | 32 | 22 | 19 |
| 16846-8-8 | 10648-8-8* | 12 | 1/2 | -8 | 12.7 | 3/4x16 | 56 | 34 | 22 | 22 |
| 16846-10-8 | 10648-10-8* | 12 | 1/2 | -8 | 12.7 | 7/8x14 | 59 | 36 | 22 | 27 |
| 10646-12-8 | 10648-12-8 | 12 | 1/2 | -8 | 12.7 | 1 1/16x12 | 62 | 39 | 27 | 32 |
| 16846-8-10 | 16848-8-10 | 16 | 5/8 | -10 | 15.9 | 3/4x16 | 57 | 32 | 22 | 22 |
| 16846-10-10 | 10648-10-10* | 16 | 5/8 | -10 | 15.9 | 7/8x14 | 62 | 37 | 24 | 27 |
| 10646-12-10 | 10648-12-10* | 16 | 5/8 | -10 | 15.9 | 1 1/16x12 | 64 | 39 | 27 | 32 |
| 16846-8-12 | 16848-8-12 | 19 | 3/4 | -12 | 19.1 | 3/4x16 | 58 | 32 | 24 | 22 |
| 16846-10-12 | 16848-10-12 | 19 | 3/4 | -12 | 19.1 | 7/8x14 | 61 | 35 | 24 | 27 |
| 10646-12-12 | 10648-12-12* | 19 | 3/4 | -12 | 19.1 | 1 1/16x12 | 67 | 41 | 27 | 32 |
| 10646-14-12 | 10648-14-12 | 19 | 3/4 | -12 | 19.1 | 1 3/16x12 | 68 | 42 | 30 | 36 |
| 10646-16-12 | 10648-16-12 | 19 | 3/4 | -12 | 19.1 | 1 5/16x12 | 71 | 45 | 32 | 41 |
| 10646-12-16 | 10648-12-16 | 25 | 1 | -16 | 25.4 | 1 1/16x12 | 73 | 44 | 32 | 32 |
| 10646-16-16 | 10648-16-16* | 25 | 1 | -16 | 25.4 | 1 5/16x12 | 78 | 45 | 32 | 41 |
| 10646-20-16 | 10648-20-16* | 25 | 1 | -16 | 25.4 | 1 5/8x12 | 80 | 50 | 41 | 50 |
| 10646-16-20 | 10648-16-20 | 31 | 1 1/4 | -20 | 31.8 | 1 5/16x12 | 97 | 50 | 46 | 41 |
| 10646-20-20 | 10648-20-20 | 31 | 1 1/4 | -20 | 31.8 | 1 5/8x12 | 89 | 51 | 46 | 50 |
| 10648-24-24 | 10648-24-24 | 38 | 1 1/2 | -24 | 38.1 | 1 7/8x12 | 98 | 60 | 55 | 60 |
| 10648-32-32 | 10648-32-32 | 51 | 2 | -32 | 50.8 | 2 1/2x12 | 120 | 72 | 65 | 75 |

46/48 Series

Approved **fitting series** for hose types, depending on size: Also available in stainless steel. Details can be found in CAT 4400.1/UK

| | | | | | | | | | | | | | | | | | |
|------------------------|-------|-------|-------|-------|-------|---------|------------|-------|-------|-----|-------|-------|------------|-------|-------|-----|-----|
| 46 or 48 | 441 | 461LT | 462 | 462TC | 462ST | 629PU | 692PU Twin | | | | | | | | | | |
| 46 | 463 | 492 | 492ST | 492TC | 692 | 692Twin | 692TC BCH1 | | | | | | | | | | |
| 48 | 301SN | 304 | 387 | 387ST | 387TC | 421RH | 421SN | 426 | 421TC | 436 | 441RH | 462PU | 462PU Twin | BCH2 | HT2 | ... | |
| | 471TC | 477 | 477ST | 477TC | 477RH | 487 | 487ST | 487TC | 493 | 787 | 787TC | 787ST | 797 | 797TC | 797ST | 811 | 881 |



Cc-21

Catalogue 4400/UK

Medium Pressure
SAE

Parkrimp No-Skive Fittings
46/48 Series

08 Female SAE 45° – Swivel Straight

SAE J516

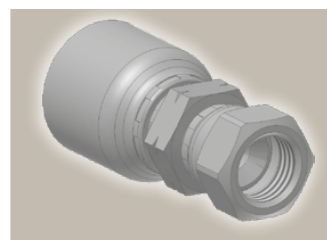
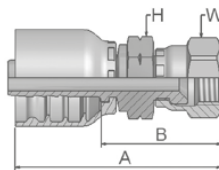

| Part Number | | Hose I.D. | | | | Thread | A | B | H | W |
|-------------|-----------|-----------|------|------|-----|--------|----|----|----|----|
| 46 series | 48 series | DN | Inch | Size | mm | UNF | mm | mm | mm | |
| | 10848-6-6 | 10 | 3/8 | -6 | 9.5 | 5/8x18 | 57 | | 34 | 19 |

37/3V Female JIC 37° SAE 45° – Dual Flare Swivel Female 45° Elbow

ISO 12151-5-SWE 45° – DKJ 45°

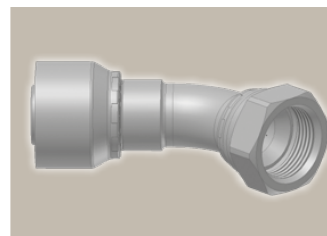
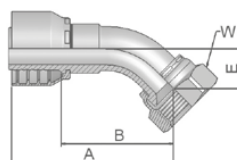

| Part Number | | Hose I.D. | | | | Thread | A | B | E | W |
|-------------|-------------|-----------|-------|------|------|-----------|-----|-----|----|----|
| 46 series | 48 series | DN | Inch | Size | mm | UNF | mm | mm | mm | mm |
| 13V46-4-4 | 13V48-4-4 | 6 | 1/4 | -4 | 6.4 | 7/16x20 | 53 | 29 | 10 | 17 |
| 13V46-5-4 | 13V48-5-4 | 6 | 1/4 | -4 | 6.4 | 1/2x20 | 57 | 33 | 9 | 17 |
| 13746-6-4 | 13748-6-4 | 6 | 1/4 | -4 | 6.4 | 9/16x18 | 55 | 31 | 11 | 19 |
| 13V46-5-5 | 13V48-5-5 | 8 | 5/16 | -5 | 7.9 | 1/2x20 | 53 | 29 | 10 | 17 |
| 13746-6-5 | 13748-6-5 | 8 | 5/16 | -5 | 7.9 | 9/16x18 | 58 | 35 | 10 | 19 |
| 13746-6-6 | 13748-6-6 | 10 | 3/8 | -6 | 9.5 | 9/16x18 | 60 | 37 | 11 | 19 |
| 13V46-8-6 | 13V48-8-6 | 10 | 3/8 | -6 | 9.5 | 3/4x16 | 67 | 44 | 15 | 22 |
| 13V46-10-6 | 13V48-10-6 | 10 | 3/8 | -6 | 9.5 | 7/8 14 | 69 | 46 | 17 | 27 |
| 13V46-8-8 | 13V48-8-8 | 12 | 1/2 | -8 | 12.7 | 3/4x16 | 61 | 37 | 15 | 22 |
| 13V46-10-8 | 13V48-10-8 | 12 | 1/2 | -8 | 12.7 | 7/8x14 | 70 | 46 | 16 | 27 |
| 13V46-10-10 | 13V48-10-10 | 16 | 5/8 | -10 | 15.9 | 7/8x14 | 69 | 44 | 16 | 27 |
| 13746-12-10 | 13748-12-10 | 16 | 5/8 | -10 | 15.9 | 1 1/16x12 | 74 | 49 | 21 | 32 |
| 13746-12-12 | 13748-12-12 | 19 | 3/4 | -12 | 19.1 | 1 1/16x12 | 83 | 58 | 22 | 32 |
| 13746-14-12 | 13748-14-12 | 19 | 3/4 | -12 | 19.1 | 1 3/16x12 | 84 | 58 | 22 | 36 |
| 13746-16-12 | 13748-16-12 | 19 | 3/4 | -12 | 19.1 | 1 5/16x12 | 84 | 58 | 24 | 41 |
| 13746-12-16 | 13748-12-16 | 25 | 1 | -16 | 25.4 | 1 1/16x12 | 91 | 61 | 21 | 32 |
| 13746-16-16 | 13748-16-16 | 25 | 1 | -16 | 25.4 | 1 5/16x12 | 99 | 70 | 24 | 41 |
| 13746-20-16 | 13748-20-16 | 25 | 1 | -16 | 25.4 | 1 5/8x12 | 101 | 71 | 26 | 50 |
| 13746-20-20 | | 31 | 1 1/4 | -20 | 31.8 | 1 5/8x12 | 129 | 92 | 32 | 50 |
| | 13748-20-20 | 31 | 1 1/4 | -20 | 31.8 | 1 5/8x12 | 135 | 88 | 32 | 50 |
| | 13748-24-24 | 38 | 1 1/2 | -24 | 38.1 | 1 7/8x12 | 165 | 127 | 58 | 60 |

Approved **fitting series** for hose types, depending on size: Also available in stainless steel. Details can be found in CAT 4400.1/UK

46 or **48** 441 461LT 462 462TC 462ST 629PU 692PU Twin

46 463 492 492ST 492TC 692 692Twin 692TC BCH1

48 301SN 304 387 387ST 387TC 421RH 421SN 426 421TC 436 441RH 462PU 462PU Twin BCH2 HT2 ...

471TC 477 477ST 477TC 477RH 487 487ST 487TC 493 787 787TC 787ST 797 797TC 797ST 811 881



Cc-22

Catalogue 4400/UK

Medium Pressure
SAE

Parkrimp No-Skive Fittings
46/48 Series

39/3W Female JIC 37°
SAE 45° - Dual Flare
Swivel Female 90° Elbow
ISO 12151-5-SWES - DKJ 90°

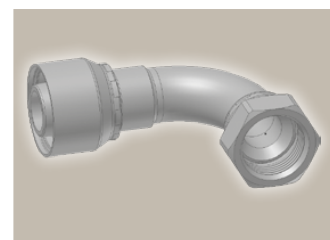
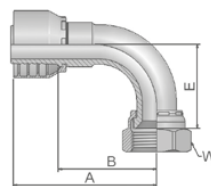

| Part Number | | Hose I.D. | | | | Thread | A | B | E | W |
|-------------|-------------|-----------|-------|------|------|-----------|-----|-----|----|----|
| 46 series | 48 series | DN | Inch | Size | mm | UNF | mm | mm | mm | mm |
| 13W46-4-4 | 13W48-4-4 | 6 | 1/4 | -4 | 6.4 | 7/16x20 | 48 | 24 | 21 | 17 |
| 13W46-5-4 | 13W48-5-4 | 6 | 1/4 | -4 | 6.4 | 1/2x20 | 57 | 34 | 21 | 17 |
| 13946-6-4 | 13948-6-4 | 6 | 1/4 | -4 | 6.4 | 9/16x18 | 49 | 25 | 23 | 19 |
| 13W46-5-5 | 13W48-5-5 | 8 | 5/16 | -5 | 7.9 | 1/2x20 | 49 | 25 | 21 | 17 |
| 13946-6-5 | 13948-6-5 | 8 | 5/16 | -5 | 7.9 | 9/16x18 | 51 | 28 | 23 | 19 |
| 13W46-4-6 | 13W48-4-6 | 10 | 3/8 | -6 | 9.5 | 7/16x20 | 46 | 23 | 21 | 17 |
| 13946-6-6 | 13948-6-6 | 10 | 3/8 | -6 | 9.5 | 9/16x18 | 51 | 28 | 23 | 19 |
| 13W46-8-6 | 13W48-8-6 | 10 | 3/8 | -6 | 9.5 | 3/4x16 | 59 | 36 | 29 | 22 |
| 13W46-10-6 | 13W48-10-6 | 10 | 3/8 | -6 | 9.5 | 7/8x14 | 61 | 38 | 32 | 27 |
| 13946-6-8 | 13948-6-8 | 12 | 1/2 | -8 | 12.7 | 9/16x18 | 54 | 30 | 23 | 19 |
| 13W46-8-8 | 13W48-8-8 | 12 | 1/2 | -8 | 12.7 | 3/4x16 | 55 | 31 | 29 | 22 |
| 13W46-10-8 | 13W48-10-8 | 12 | 1/2 | -8 | 12.7 | 7/8x14 | 63 | 39 | 32 | 27 |
| 13W46-10-10 | 13W48-10-10 | 16 | 5/8 | -10 | 15.9 | 7/8x14 | 64 | 39 | 33 | 27 |
| 13946-12-10 | 13948-12-10 | 16 | 5/8 | -10 | 15.9 | 1 1/16x12 | 74 | 49 | 48 | 32 |
| 13946-12-12 | 13948-12-12 | 19 | 3/4 | -12 | 19.1 | 1 1/16x12 | 80 | 54 | 48 | 32 |
| 13946-14-12 | 13948-14-12 | 19 | 3/4 | -12 | 19.1 | 1 3/16x12 | 80 | 54 | 51 | 36 |
| 13946-16-12 | 13948-16-12 | 19 | 3/4 | -12 | 19.1 | 1 5/16x12 | 80 | 54 | 56 | 41 |
| 13946-12-16 | 13948-12-16 | 25 | 1 | -16 | 25.4 | 1 1/16x12 | 87 | 58 | 48 | 32 |
| 13946-16-16 | 13948-16-16 | 25 | 1 | -16 | 25.4 | 1 5/16x12 | 98 | 68 | 56 | 41 |
| 13946-20-16 | 13948-20-16 | 25 | 1 | -16 | 25.4 | 1 5/8x12 | 98 | 68 | 62 | 50 |
| 13946-20-20 | | 31 | 1 1/4 | -20 | 31.8 | 1 5/8x12 | 124 | 86 | 70 | 50 |
| | 13948-20-20 | 31 | 1 1/4 | -20 | 31.8 | 1 5/8x12 | 129 | 82 | 70 | 50 |
| | 13948-24-24 | 38 | 1 1/2 | -24 | 38.1 | 1 7/8x12 | 140 | 102 | 91 | 60 |

46/48 Series

Approved **fitting series** for hose types, depending on size: Also available in stainless steel. Details can be found in CAT 4400.1/UK

46 or **48** 441 461LT 462 462TC 462ST 629PU 692PU Twin

46 463 492 492ST 492TC 692 692Twin 692TC BCH1

48 301SN 304 387 387ST 387TC 421RH 421SN 426 421TC 436 441RH 462PU 462PU Twin BCH2 HT2 ...

471TC 477 477ST 477TC 477RH 487 487ST 487TC 493 787 787TC 787ST 797 797TC 797ST 811 881



Medium Pressure
SAE

Parkrimp No-Skive Fittings
46/48 Series

41/3Y Female JIC 37° / 45° Swivel Female 90° Elbow (Long)

ISO 12151-5-SWEL – DKJ 90°L

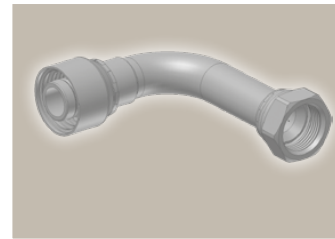
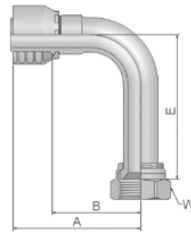

| Part Number | | Hose I.D. | | | | Thread | A | B | E | W |
|-------------|-------------|-----------|------|------|------|-----------|----|------|-----|----|
| 46 series | 48 series | DN | Inch | Size | mm | UNF | mm | mm | mm | mm |
| 13Y46-4-4 | 13Y48-4-4 | 6 | 1/4 | -4 | 6.4 | 7/16x20 | 61 | 37 | 46 | 17 |
| 14146-6-4 | 14148-6-4 | 6 | 1/4 | -4 | 6.4 | 9/16x18 | 57 | 34 | 55 | 19 |
| 14146-6-6 | 14148-6-6 | 10 | 3/8 | -6 | 9.5 | 9/16x18 | 57 | 34 | 54 | 19 |
| 13Y46-8-6 | | 10 | 3/8 | -6 | 9.5 | 3/4x16 | 59 | 36.5 | 62 | 22 |
| | 13Y48-8-6 | 10 | 3/8 | -6 | 9.5 | 3/4x16 | 55 | 32 | 62 | 22 |
| 13Y46-8-8 | 13Y48-8-8 | 12 | 1/2 | -8 | 12.7 | 3/4x16 | 59 | 36 | 64 | 22 |
| 13Y46-10-10 | 13Y48-10-10 | 16 | 5/8 | -10 | 15.9 | 7/8x14 | 61 | 36 | 70 | 27 |
| 14146-12-12 | 14148-12-12 | 19 | 3/4 | -12 | 19.1 | 1 1/16x12 | 80 | 54 | 96 | 32 |
| 14146-16-16 | 14148-16-16 | 25 | 1 | -16 | 25.4 | 1 5/16x12 | 98 | 68 | 110 | 41 |

Approved **fitting series** for hose types, depending on size: Also available in stainless steel. Details can be found in CAT 4400.1/UK

46 or **48** 441 | 461LT | 462 | 462TC | 462ST | 629PU | 692PU Twin

46 463 | 492 | 492ST | 492TC | 692 | 692Twin | 692TC | BCH1

48 301SN | 304 | 387 | 387ST | 387TC | 421RH | 421SN | 426 | 421TC | 436 | 441RH | 462PU | 462PU Twin | BCH2 | HT2 | ...

471TC | 477 | 477ST | 477TC | 477RH | 487 | 487ST | 487TC | 493 | 787 | 787TC | 787ST | 797 | 797TC | 797ST | 811 | 881



15 ISO 6162-1-Flange Straight

ISO 12151-3-S-L – SFL
(21.0 MPa/ 3000 psi)

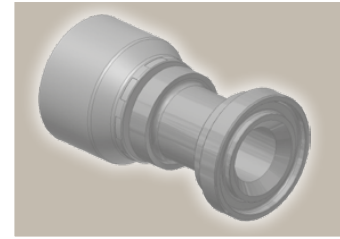
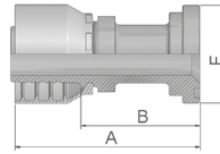

| Part Number | | Hose I.D. | | | | Flange | A | B | F |
|-------------|-------------|-----------|-------|------|------|--------|-----|----|----|
| 46 series | 48 series | DN | Inch | Size | mm | Inch | mm | mm | mm |
| 11546-8-8 | 11548-8-8 | 12 | 1/2 | -8 | 12.7 | 1/2 | 74 | 50 | 30 |
| 11546-12-8 | 11548-12-8 | 12 | 1/2 | -8 | 12.7 | 3/4 | 51 | 27 | 38 |
| 11546-12-10 | 11548-12-10 | 16 | 5/8 | -10 | 15.9 | 3/4 | 55 | 30 | 38 |
| 11546-12-12 | 11548-12-12 | 19 | 3/4 | -12 | 19.1 | 3/4 | 81 | 55 | 38 |
| 11546-16-12 | 11548-16-12 | 19 | 3/4 | -12 | 19.1 | 1 | 56 | 30 | 45 |
| 11546-20-12 | 11548-20-12 | 19 | 3/4 | -12 | 19.1 | 1 1/4 | 62 | 36 | 51 |
| 11546-16-16 | 11548-16-16 | 25 | 1 | -16 | 25.4 | 1 | 84 | 54 | 45 |
| 11546-20-16 | 11548-20-16 | 25 | 1 | -16 | 25.4 | 1 1/4 | 65 | 35 | 51 |
| 11546-24-16 | 11548-24-16 | 25 | 1 | -16 | 25.4 | 1 1/2 | 68 | 38 | 60 |
| | 11548-16-20 | 31 | 1 1/4 | -20 | 31.8 | 1 | 111 | 64 | 45 |
| 11546-20-20 | | 31 | 1 1/4 | -20 | 31.8 | 1 1/4 | 114 | 76 | 51 |
| | 11548-20-20 | 31 | 1 1/4 | -20 | 31.8 | 1 1/4 | 119 | 72 | 51 |
| 11546-24-20 | | 31 | 1 1/4 | -20 | 31.8 | 1 1/2 | 72 | 35 | 60 |
| | 11548-24-20 | 31 | 1 1/4 | -20 | 31.8 | 1 1/2 | 82 | 35 | 60 |
| | 11548-32-20 | 31 | 1 1/4 | -20 | 31.8 | 2 | 123 | 76 | 71 |
| | 11548-24-24 | 38 | 1 1/2 | -24 | 38.1 | 1 1/2 | 117 | 79 | 60 |
| | 11548-32-24 | 38 | 1 1/2 | -24 | 38.1 | 2 | 80 | 42 | 71 |
| | 11548-24-32 | 51 | 2 | -32 | 50.8 | 1 1/2 | 129 | 81 | 60 |
| | 11548-32-32 | 51 | 2 | -32 | 50.8 | 2 | 127 | 79 | 71 |

To select corresponding half-flange and O-ring see section Eb.

46/48 Series

Approved **fitting series** for hose types, depending on size: Also available in stainless steel. Details can be found in CAT 4400.1/UK

| | | | | | | | | | | | | | | | | | |
|------------------------|-------|-------|-------|-------|-------|---------|------------|-------|-------|-----|-------|-------|------------|-------|-------|-----|-----|
| 46 or 48 | 441 | 461LT | 462 | 462TC | 462ST | 629PU | 692PU Twin | | | | | | | | | | |
| 46 | 463 | 492 | 492ST | 492TC | 692 | 692Twin | 692TC | BCH1 | | | | | | | | | |
| 48 | 301SN | 304 | 387 | 387ST | 387TC | 421RH | 421SN | 426 | 421TC | 436 | 441RH | 462PU | 462PU Twin | BCH2 | HT2 | ... | |
| | 471TC | 477 | 477ST | 477TC | 477RH | 487 | 487ST | 487TC | 493 | 787 | 787TC | 787ST | 797 | 797TC | 797ST | 811 | 881 |



17

ISO 6162-1 Flange 45° Elbow

ISO 12151-3 – E45 – L – SFL 45°
(21.0 MPa/ 3000 psi)

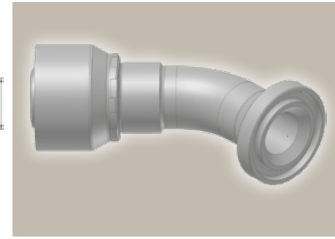
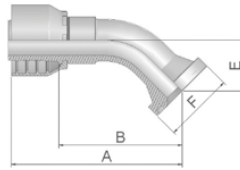

| Part Number | | Hose I.D. | | | | Flange | A | B | E | F |
|-------------|-------------|-----------|-------|------|------|--------|-----|-----|----|----|
| 46 series | 48 series | DN | Inch | Size | mm | Inch | mm | mm | mm | mm |
| 11746-8-8 | 11748-8-8 | 12 | 1/2 | -8 | 12.7 | 1/2 | 72 | 48 | 20 | 30 |
| 11746-12-8 | 11748-12-8 | 12 | 1/2 | -8 | 12.7 | 3/4 | 70 | 47 | 21 | 38 |
| 11746-12-10 | 11748-12-10 | 16 | 5/8 | -10 | 15.9 | 3/4 | 75 | 50 | 24 | 38 |
| 11746-12-12 | 11748-12-12 | 19 | 3/4 | -12 | 19.1 | 3/4 | 88 | 62 | 26 | 38 |
| 11746-16-12 | 11748-16-12 | 19 | 3/4 | -12 | 19.1 | 1 | 88 | 62 | 26 | 45 |
| 11746-20-12 | 11748-20-12 | 19 | 3/4 | -12 | 19.1 | 1 1/4 | 87 | 61 | 25 | 51 |
| 11746-16-16 | | 25 | 1 | -16 | 25.4 | 1 | 109 | 78 | 32 | 45 |
| | 11748-16-16 | 25 | 1 | -16 | 25.4 | 1 | 107 | 78 | 32 | 45 |
| 11746-20-16 | 11748-20-16 | 25 | 1 | -16 | 25.4 | 1 1/4 | 109 | 79 | 32 | 51 |
| | 11748-16-20 | 31 | 1 1/4 | -20 | 31.8 | 1 | 141 | 94 | 38 | 45 |
| 11746-20-20 | | 31 | 1 1/4 | -20 | 31.8 | 1 1/4 | 136 | 98 | 38 | 51 |
| | 11748-20-20 | 31 | 1 1/4 | -20 | 31.8 | 1 1/4 | 141 | 94 | 38 | 51 |
| 11746-24-20 | | 31 | 1 1/4 | -20 | 31.8 | 1 1/2 | 136 | 98 | 38 | 60 |
| | 11748-24-20 | 31 | 1 1/4 | -20 | 31.8 | 1 1/2 | 141 | 94 | 38 | 60 |
| | 11748-24-24 | 38 | 1 1/2 | -24 | 38.1 | 1 1/2 | 151 | 113 | 44 | 60 |
| | 11748-32-24 | 38 | 1 1/2 | -24 | 38.1 | 2 | 150 | 112 | 44 | 71 |
| | 11748-24-32 | 51 | 2 | -32 | 50.8 | 1 1/2 | 164 | 115 | 44 | 60 |
| | 11748-32-32 | 51 | 2 | -32 | 50.8 | 2 | 202 | 153 | 56 | 71 |

To select corresponding half-flange and O-ring see section Eb.

Approved **fitting series** for hose types, depending on size: Also available in stainless steel. Details can be found in CAT 4400.1/UK

| | | | | | | | | | | | | | | | | | |
|------------------------|-------|-------|-------|-------|-------|---------|------------|-------|-------|-----|-------|-------|------------|-------|-------|-----|-----|
| 46 or 48 | 441 | 461LT | 462 | 462TC | 462ST | 629PU | 692PU Twin | | | | | | | | | | |
| 46 | 463 | 492 | 492ST | 492TC | 692 | 692Twin | 692TC | BCH1 | | | | | | | | | |
| 48 | 301SN | 304 | 387 | 387ST | 387TC | 421RH | 421SN | 426 | 421TC | 436 | 441RH | 462PU | 462PU Twin | BCH2 | HT2 | ... | |
| | 471TC | 477 | 477ST | 477TC | 477RH | 487 | 487ST | 487TC | 493 | 787 | 787TC | 787ST | 797 | 797TC | 797ST | 811 | 881 |

19 ISO 6162-1-Flange 90° Elbow

ISO 12151-3 – E– L – SFL 90°
(21.0 MPa/ 3000 psi)

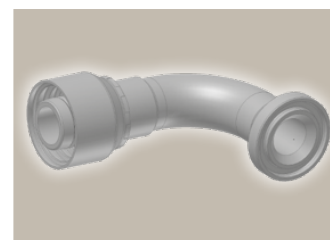
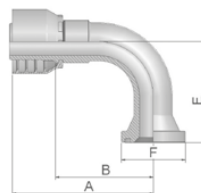

| Part Number | | Hose I.D. | | | | Flange | A | B | E | F |
|-------------|-------------|-----------|-------|------|------|--------|-----|-----|-----|----|
| 46 series | 48 series | DN | Inch | Size | mm | Inch | mm | mm | mm | mm |
| 11946-8-8 | 11948-8-8 | 12 | 1/2 | -8 | 12.7 | 1/2 | 64 | 41 | 41 | 30 |
| 11946-12-8 | 11948-12-8 | 12 | 1/2 | -8 | 12.7 | 3/4 | 70 | 47 | 43 | 38 |
| 11946-12-10 | 11948-12-10 | 16 | 5/8 | -10 | 15.9 | 3/4 | 78 | 53 | 52 | 38 |
| 11946-16-10 | 11948-16-10 | 16 | 5/8 | -10 | 15.9 | 1 | 78 | 53 | 53 | 45 |
| 11946-12-12 | 11948-12-12 | 19 | 3/4 | -12 | 19.1 | 3/4 | 80 | 54 | 58 | 38 |
| 11946-16-12 | 11948-16-12 | 19 | 3/4 | -12 | 19.1 | 1 | 80 | 54 | 58 | 45 |
| 11946-20-12 | 11948-20-12 | 19 | 3/4 | -12 | 19.1 | 1 1/4 | 80 | 54 | 54 | 51 |
| 11946-12-16 | 11948-12-16 | 25 | 1 | -16 | 25.4 | 3/4 | 98 | 68 | 70 | 38 |
| 11946-16-16 | 11948-16-16 | 25 | 1 | -16 | 25.4 | 1 | 98 | 68 | 70 | 45 |
| 11946-20-16 | 11948-20-16 | 25 | 1 | -16 | 25.4 | 1 1/4 | 98 | 68 | 69 | 51 |
| | 11948-24-16 | 25 | 1 | -16 | 25.4 | 1 1/2 | 100 | 70 | 62 | 60 |
| | 11948-16-20 | 31 | 1 1/4 | -20 | 31.8 | 1 | 129 | 82 | 90 | 45 |
| 11946-20-20 | | 31 | 1 1/4 | -20 | 31.8 | 1 1/4 | 124 | 86 | 90 | 51 |
| | 11948-20-20 | 31 | 1 1/4 | -20 | 31.8 | 1 1/4 | 130 | 83 | 90 | 51 |
| 11946-24-20 | | 31 | 1 1/4 | -20 | 31.8 | 1 1/2 | 124 | 86 | 90 | 60 |
| | 11948-24-20 | 31 | 1 1/4 | -20 | 31.8 | 1 1/2 | 129 | 82 | 90 | 60 |
| | 11948-32-20 | 31 | 1 1/4 | -20 | 31.8 | 2 | 130 | 83 | 67 | 71 |
| | 11948-24-24 | 38 | 1 1/2 | -24 | 38.1 | 1 1/2 | 149 | 111 | 104 | 60 |
| | 11948-32-24 | 38 | 1 1/2 | -24 | 38.1 | 2 | 139 | 101 | 104 | 71 |
| | 11948-24-32 | 51 | 2 | -32 | 50.8 | 1 1/2 | 154 | 106 | 104 | 60 |
| | 11948-32-32 | 51 | 2 | -32 | 50.8 | 2 | 180 | 132 | 138 | 71 |

To select corresponding half-flange and O-ring see section Eb.

46/48 Series

Approved **fitting series** for hose types, depending on size: Also available in stainless steel. Details can be found in CAT 4400.1/UK

46 or **48** 441 | 461LT | 462 | 462TC | 462ST | 629PU | 692PU Twin

46 463 | 492 | 492ST | 492TC | 692 | 692Twin | 692TC | BCH1

48 301SN | 304 | 387 | 387ST | 387TC | 421RH | 421SN | 426 | 421TC | 436 | 441RH | 462PU | 462PU Twin | BCH2 | HT2 | ...

471TC | 477 | 477ST | 477TC | 477RH | 487 | 487ST | 487TC | 493 | 787 | 787TC | 787ST | 797 | 797TC | 797ST | 811 | 881



6A ISO 6162-2-Flange Straight

ISO 12151-3-S-S – SFS
(42.0 MPa/ 6000 psi)

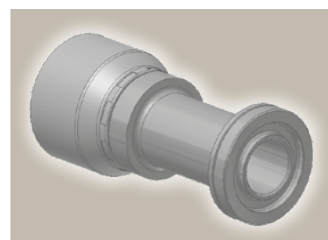
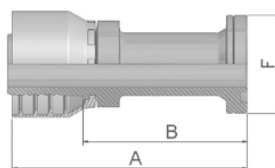

| Part Number | | Hose I.D. | | | | Flange | A | B | F |
|-------------|-------------|-----------|-------|------|------|--------|-----|-----|----|
| 46 series | 48 series | DN | Inch | Size | mm | Inch | mm | mm | mm |
| 16A46-8-8 | 16A48-8-8 | 12 | 1/2 | -8 | 12.7 | 1/2 | 75 | 51 | 32 |
| | 16A48-12-10 | 16 | 5/8 | -10 | 15.9 | 3/4 | 60 | 35 | 41 |
| 16A46-12-12 | 16A48-12-12 | 19 | 3/4 | -12 | 19.1 | 3/4 | 96 | 70 | 41 |
| 16A46-12-16 | 16A48-12-16 | 25 | 1 | -16 | 25.4 | 3/4 | 99 | 69 | 41 |
| 16A46-16-16 | 16A48-16-16 | 25 | 1 | -16 | 25.4 | 1 | 111 | 81 | 48 |
| 16A46-20-20 | | 31 | 1 1/4 | -20 | 31.8 | 1 1/4 | 122 | 84 | 54 |
| | 16A48-20-20 | 31 | 1 1/4 | -20 | 31.8 | 1 1/4 | 130 | 83 | 54 |
| | 16A48-24-24 | 38 | 1 1/2 | -24 | 38.1 | 1 1/2 | 139 | 101 | 64 |
| | 16A48-32-32 | 51 | 2 | -32 | 50.8 | 2 | 172 | 124 | 79 |

To select corresponding half-flange and O-ring see section Eb.

6F ISO 6162-2-Flange 45° Elbow – Heavy Series

ISO 12151-3 – E45-S – SFS 45°
(42.0 MPa/ 6000 psi)

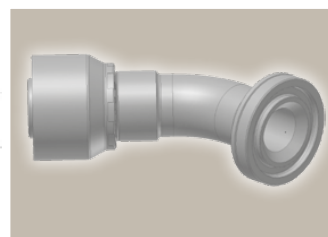
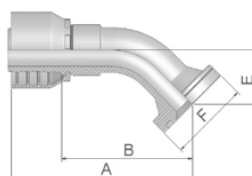

| Part Number | | Hose I.D. | | | | Flange | A | B | E | F |
|-------------|-------------|-----------|-------|------|------|--------|-----|-----|----|----|
| 46 series | 48 series | DN | Inch | Size | mm | Inch | mm | mm | mm | mm |
| 16F46-12-12 | 16F48-12-12 | 19 | 3/4 | -12 | 19,1 | 3/4 | 88 | 62 | 26 | 41 |
| 16F46-16-16 | 16F48-16-16 | 25 | 1 | -16 | 25,4 | 1 | 107 | 78 | 32 | 48 |
| | 16F48-20-20 | 31 | 1 1/4 | -20 | 31,8 | 1 1/4 | 141 | 94 | 38 | 54 |
| | 16F48-24-24 | 38 | 1 1/2 | -24 | 38,1 | 1 1/2 | 150 | 112 | 44 | 64 |
| | 16F48-32-32 | 51 | 2 | -32 | 50,8 | 2 | 200 | 152 | 56 | 79 |

To select corresponding half-flange and O-ring see section Eb.

Approved **fitting series** for hose types, depending on size: Also available in stainless steel. Details can be found in CAT 4400.1/UK

46 or **48** 441 | 461LT | 462 | 462TC | 462ST | 629PU | 692PU Twin

46 463 | 492 | 492ST | 492TC | 692 | 692Twin | 692TC | BCH1

48 301SN | 304 | 387 | 387ST | 387TC | 421RH | 421SN | 426 | 421TC | 436 | 441RH | 462PU | 462PU Twin | BCH2 | HT2 | ...

471TC | 477 | 477ST | 477TC | 477RH | 487 | 487ST | 487TC | 493 | 787 | 787TC | 787ST | 797 | 797TC | 797ST | 811 | 881

6N ISO 6162-2-Flange 90° Elbow

ISO 12151-3 – E-S – SFS 90°
(42.0 MPa/ 6000 psi)

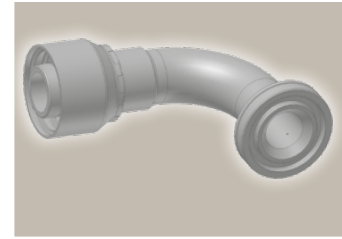
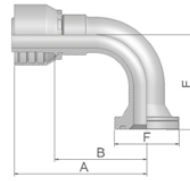

| Part Number | | Hose I.D. | | | | Flange | A | B | E | F |
|-------------|-------------|-----------|-------|------|------|--------|-----|-----|-----|----|
| 46 series | 48 series | DN | Inch | Size | mm | Inch | mm | mm | mm | |
| 16N46-8-12 | 16N48-8-12 | 19 | 3/4 | -12 | 19.1 | 1/2 | 70 | 44 | 40 | 32 |
| 16N46-12-12 | 16N48-12-12 | 19 | 3/4 | -12 | 19.1 | 3/4 | 80 | 54 | 54 | 41 |
| 16N46-16-12 | 16N48-16-12 | 19 | 3/4 | -12 | 19.1 | 1 | 80 | 54 | 53 | 48 |
| 16N46-12-16 | 16N48-12-16 | 25 | 1 | -16 | 25.4 | 3/4 | 88 | 58 | 70 | 41 |
| 16N46-16-16 | 16N48-16-16 | 25 | 1 | -16 | 25.4 | 1 | 98 | 68 | 70 | 48 |
| 16N46-20-20 | | 31 | 1 1/4 | -20 | 31.8 | 1 1/4 | 124 | 86 | 90 | 54 |
| | 16N48-20-20 | 31 | 1 1/4 | -20 | 31.8 | 1 1/4 | 129 | 82 | 90 | 54 |
| | 16N48-24-24 | 38 | 1 1/2 | -24 | 38.1 | 1 1/2 | 139 | 101 | 104 | 64 |
| | 16N48-32-32 | 51 | 2 | -32 | 50.8 | 2 | 186 | 138 | 138 | 79 |

To select corresponding half-flange and O-ring see section Eb.

46/48 Series

Approved **fitting series** for hose types, depending on size: Also available in stainless steel. Details can be found in CAT 4400.1/UK

| | | | | | | | | | | | | | | | | | |
|------------------------|-------|-------|-------|-------|-------|---------|------------|-------|-------|-----|-------|-------|------------|-------|-------|-----|-----|
| 46 or 48 | 441 | 461LT | 462 | 462TC | 462ST | 629PU | 692PU Twin | | | | | | | | | | |
| 46 | 463 | 492 | 492ST | 492TC | 692 | 692Twin | 692TC BCH1 | | | | | | | | | | |
| 48 | 301SN | 304 | 387 | 387ST | 387TC | 421RH | 421SN | 426 | 421TC | 436 | 441RH | 462PU | 462PU Twin | BCH2 | HT2 | ... | |
| | 471TC | 477 | 477ST | 477TC | 477RH | 487 | 487ST | 487TC | 493 | 787 | 787TC | 787ST | 797 | 797TC | 797ST | 811 | 881 |

JC Female ORFS Swivel – Straight Short

ISO 12151-1 – SWSA
SAE J516 – ORFS

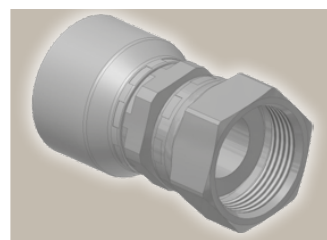
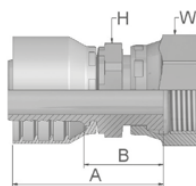

*New 3S-Fitting-Design – more information see Cc-Index

| Part Number | | Hose I.D. | | | | Thread | A | B | H | W |
|-------------|--------------|-----------|-------|------|------|------------|----|----|----|----|
| 46 series | 48 series | DN | Inch | Size | mm | UNF | mm | mm | mm | mm |
| 1JC46-4-4 | | 6 | 1/4 | -4 | 6.4 | 9/16x18 | 46 | 22 | 14 | 17 |
| | 1JC48-4-4* | 6 | 1/4 | -4 | 6.4 | 9/16x18 | 39 | 15 | 13 | 17 |
| 1JC46-6-4 | | 6 | 1/4 | -4 | 6.4 | 11/16x16 | 45 | 23 | 17 | 22 |
| | 1JC48-6-4* | 6 | 1/4 | -4 | 6.4 | 11/16x16 | 40 | 17 | 13 | 22 |
| 1JC46-8-4 | 1JC48-8-4 | 6 | 1/4 | -4 | 6.4 | 13/16x16 | 45 | 22 | 19 | 24 |
| 1JC46-6-5 | 1JC48-6-5 | 8 | 5/16 | -5 | 7.9 | 11/16x16 | 47 | 23 | 17 | 22 |
| 1JC46-4-6 | 1JC48-4-6 | 10 | 3/8 | -6 | 9.5 | 9/16x18 | 42 | 19 | 17 | 17 |
| 1JC46-6-6 | | 10 | 3/8 | -6 | 9.5 | 11/16x16 | 43 | 21 | 17 | 22 |
| | 1JC48-6-6* | 10 | 3/8 | -6 | 9.5 | 11/16x16 | 40 | 17 | 17 | 22 |
| 1JC46-8-6 | | 10 | 3/8 | -6 | 9.5 | 13/16x16 | 45 | 22 | 19 | 24 |
| | 1JC48-8-6* | 10 | 3/8 | -6 | 9.5 | 13/16x16 | 41 | 19 | 17 | 24 |
| 1JC46-6-8 | 1JC48-6-8 | 12 | 1/2 | -8 | 12.7 | 11/16x16 | 44 | 20 | 17 | 22 |
| 1JC46-8-8 | | 12 | 1/2 | -8 | 12.7 | 13/16x16 | 46 | 22 | 22 | 24 |
| | 1JC48-8-8* | 12 | 1/2 | -8 | 12.7 | 13/16x16 | 43 | 21 | 22 | 24 |
| 1JC46-10-8 | | 12 | 1/2 | -8 | 12.7 | 1x14 | 48 | 24 | 24 | 30 |
| | 1JC48-10-8* | 12 | 1/2 | -8 | 12.7 | 1x14 | 46 | 22 | 22 | 30 |
| 1JC46-12-8 | 1JC48-12-8 | 12 | 1/2 | -8 | 12.7 | 1 3/16x12 | 52 | 29 | 30 | 36 |
| 1JC46-8-10 | 1JC48-8-10 | 16 | 5/8 | -10 | 15.9 | 13/16x16 | 47 | 22 | 22 | 24 |
| 1JC46-10-10 | | 16 | 5/8 | -10 | 15.9 | 1x14 | 51 | 26 | 24 | 30 |
| | 1JC48-10-10* | 16 | 5/8 | -10 | 15.9 | 1x14 | 49 | 24 | 24 | 30 |
| 1JC46-12-10 | | 16 | 5/8 | -10 | 15.9 | 1 3/16x12 | 54 | 28 | 30 | 36 |
| | 1JC48-12-10* | 16 | 5/8 | -10 | 15.9 | 1 3/16x12 | 51 | 26 | 24 | 36 |
| 1JC46-10-12 | 1JC48-10-12 | 19 | 3/4 | -12 | 19.1 | 1x14 | 54 | 28 | 24 | 30 |
| 1JC46-12-12 | | 19 | 3/4 | -12 | 19.1 | 1 3/16x12 | 55 | 29 | 30 | 36 |
| | 1JC48-12-12* | 19 | 3/4 | -12 | 19.1 | 1 3/16x12 | 52 | 27 | 27 | 36 |
| 1JC46-16-12 | 1JC48-16-12 | 19 | 3/4 | -12 | 19.1 | 1 7/16x12 | 59 | 33 | 36 | 41 |
| | 1JC48-12-16 | 25 | 1 | -16 | 25.4 | 1 3/16x12 | 60 | 30 | 32 | 36 |
| 1JC46-16-16 | | 25 | 1 | -16 | 25.4 | 1 7/16x12 | 63 | 33 | 36 | 41 |
| | 1JC48-16-16* | 25 | 1 | -16 | 25.4 | 1 7/16x12 | 63 | 31 | 32 | 41 |
| 1JC46-20-16 | | 25 | 1 | -16 | 25.4 | 1 11/16x12 | 62 | 32 | 41 | 50 |
| | 1JC48-20-16* | 25 | 1 | -16 | 25.4 | 1 11/16x12 | 63 | 31 | 32 | 50 |
| 1JC46-20-20 | | 31 | 1 1/4 | -20 | 31.8 | 1 11/16x12 | 71 | 33 | 41 | 50 |
| | 1JC48-20-20 | 31 | 1 1/4 | -20 | 31.8 | 1 11/16x12 | 85 | 36 | 50 | 50 |

Approved **fitting series** for hose types, depending on size: Also available in stainless steel. Details can be found in CAT 4400.1/UK

46 or **48** 441 461LT 462 462TC 462ST 629PU 692PU Twin

46 463 492 492ST 492TC 692 692Twin 692TC BCH1

48 301SN 304 387 387ST 387TC 421RH 421SN 426 421TC 436 441RH 462PU 462PU Twin BCH2 HT2 ...

471TC 477 477ST 477TC 477RH 487 487ST 487TC 493 787 787TC 787ST 797 797TC 797ST 811 881



JS ORFS Swivel Female (Long)

ISO 12151-1-SWSB
SAE J516 – ORFS

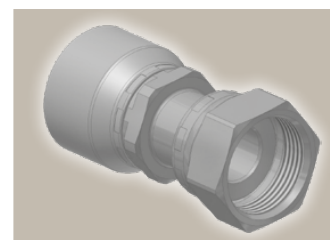
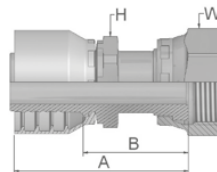

| Part Number | | Hose I.D. | | | | Thread | A | B | H | W |
|-------------|-------------|-----------|-------|------|------|------------|-----|----|----|----|
| 46 series | 48 series | DN | Inch | Size | mm | UNF | mm | mm | mm | mm |
| 1JS46-4-4 | | 6 | 1/4 | -4 | 6.4 | 9/16x18 | 53 | 29 | 14 | 17 |
| | 1JS48-4-4 | 6 | 1/4 | -4 | 6.4 | 9/16x18 | 51 | 29 | 14 | 17 |
| 1JS46-6-4 | | 6 | 1/4 | -4 | 6.4 | 11/16x16 | 56 | 31 | 17 | 22 |
| | 1JS48-6-4 | 6 | 1/4 | -4 | 6.4 | 11/16x16 | 54 | 31 | 17 | 22 |
| 1JS46-6-5 | 1JS48-6-5 | 8 | 5/16 | -5 | 7.9 | 11/16x16 | 55 | 31 | 17 | 22 |
| | 1JS48-4-6 | 10 | 3/8 | -6 | 9.5 | 9/16x18 | 53 | 31 | 14 | 17 |
| 1JS46-6-6 | 1JS48-6-6 | 10 | 3/8 | -6 | 9.5 | 11/16x16 | 52 | 29 | 17 | 22 |
| 1JS46-8-6 | 1JS48-8-6 | 10 | 3/8 | -6 | 9.5 | 13/16x16 | 58 | 35 | 19 | 24 |
| 1JS46-6-8 | 1JS48-6-8 | 12 | 1/2 | -8 | 12.7 | 11/16x16 | 52 | 29 | 17 | 22 |
| 1JS46-8-8 | 1JS48-8-8 | 12 | 1/2 | -8 | 12.7 | 13/16x16 | 57 | 33 | 22 | 24 |
| 1JS46-10-8 | 1JS48-10-8 | 12 | 1/2 | -8 | 12.7 | 1x14 | 63 | 39 | 24 | 30 |
| 1JS46-10-10 | 1JS48-10-10 | 16 | 5/8 | -10 | 15.9 | 1x14 | 65 | 39 | 24 | 30 |
| 1JS46-12-10 | 1JS48-12-10 | 16 | 5/8 | -10 | 15.9 | 1 3/16x12 | 70 | 45 | 30 | 36 |
| | 1JS48-10-12 | 19 | 3/4 | -12 | 19.1 | 1x14 | 65 | 39 | 24 | 30 |
| 1JS46-12-12 | 1JS48-12-12 | 19 | 3/4 | -12 | 19.1 | 1 3/16x12 | 71 | 45 | 30 | 36 |
| 1JS46-16-12 | 1JS48-16-12 | 19 | 3/4 | -12 | 19.1 | 1 7/16x12 | 73 | 47 | 36 | 41 |
| 1JS46-16-16 | 1JS48-16-16 | 25 | 1 | -16 | 25.4 | 1 7/16x12 | 76 | 46 | 36 | 41 |
| 1JS46-20-20 | | 31 | 1 1/4 | -20 | 31.8 | 1 11/16x12 | 88 | 50 | 41 | 50 |
| | 1JS48-20-20 | 31 | 1 1/4 | -20 | 31.8 | 1 11/16x12 | 102 | 54 | 46 | 50 |
| | 1JS48-24-24 | 38 | 1 1/2 | -24 | 38.1 | 2x12 | 99 | 62 | 50 | 60 |

46/48 Series

Approved **fitting series** for hose types, depending on size: Also available in stainless steel. Details can be found in CAT 4400.1/UK

46 or **48** 441 461LT 462 462TC 462ST 629PU 692PU Twin

46 463 492 492ST 492TC 692 692Twin 692TC BCH1

48 301SN 304 387 387ST 387TC 421RH 421SN 426 421TC 436 441RH 462PU 462PU Twin BCH2 HT2 ...

471TC 477 477ST 477TC 477RH 487 487ST 487TC 493 787 787TC 787ST 797 797TC 797ST 811 881

J7 Female ORFS – Swivel 45° Elbow

ISO 12151-1 – SWE 45°
SAE J516 – ORFS 45°

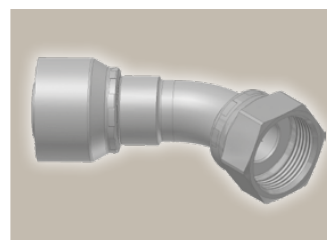
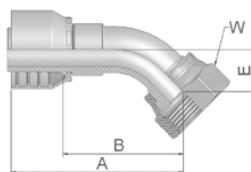

| Part Number | | Hose I.D. | | | | Thread | A | B | E | W |
|-------------|-------------|-----------|-------|------|------|------------|-----|-----|----|----|
| 46 series | 48 series | DN | Inch | Size | mm | UNF | mm | mm | mm | mm |
| 1J746-4-4 | 1J748-4-4 | 6 | 1/4 | -4 | 6.4 | 9/16x18 | 54 | 31 | 10 | 17 |
| 1J746-6-4 | 1J748-6-4 | 6 | 1/4 | -4 | 6.4 | 11/16x16 | 53 | 30 | 11 | 22 |
| 1J746-8-4 | 1J748-8-4 | 6 | 1/4 | -4 | 6.4 | 13/16x16 | 59 | 34 | 15 | 24 |
| 1J746-6-5 | 1J748-6-5 | 8 | 5/16 | -5 | 7.9 | 11/16x16 | 56 | 32 | 11 | 22 |
| 1J746-6-6 | 1J748-6-6 | 10 | 3/8 | -6 | 9.5 | 11/16x16 | 54 | 31 | 11 | 22 |
| 1J746-8-6 | 1J748-8-6 | 10 | 3/8 | -6 | 9.5 | 13/16x16 | 59 | 36 | 15 | 24 |
| 1J746-6-8 | | 12 | 1/2 | -8 | 12.7 | 11/16x16 | 57 | 33 | 11 | 22 |
| | 1J748-6-8 | 12 | 1/2 | -8 | 12.7 | 11/16 | 57 | 33 | 11 | 22 |
| 1J746-8-8 | 1J748-8-8 | 12 | 1/2 | -8 | 12.7 | 13/16x16 | 61 | 38 | 15 | 24 |
| 1J746-10-8 | 1J748-10-8 | 12 | 1/2 | -8 | 12.7 | 1x14 | 65 | 41 | 16 | 30 |
| 1J746-12-8 | 1J748-12-8 | 12 | 1/2 | -8 | 12.7 | 1 3/16x12 | 77 | 53 | 21 | 36 |
| 1J746-10-10 | 1J748-10-10 | 16 | 5/8 | -10 | 15.9 | 1x14 | 67 | 42 | 16 | 30 |
| 1J746-12-10 | 1J748-12-10 | 16 | 5/8 | -10 | 15.9 | 1 3/16x12 | 80 | 55 | 21 | 36 |
| 1J746-10-12 | 1J748-10-12 | 19 | 3/4 | -12 | 19.1 | 1x14 | 73 | 47 | 16 | 30 |
| 1J746-12-12 | 1J748-12-12 | 19 | 3/4 | -12 | 19.1 | 1 3/16x12 | 83 | 57 | 21 | 36 |
| 1J746-16-12 | 1J748-16-12 | 19 | 3/4 | -12 | 19.1 | 1 7/16x12 | 94 | 68 | 24 | 41 |
| 1J746-12-16 | 1J748-12-16 | 25 | 1 | -16 | 25.4 | 1 3/16x12 | 91 | 61 | 21 | 36 |
| 1J746-16-16 | 1J748-16-16 | 25 | 1 | -16 | 25.4 | 1 7/16x12 | 99 | 69 | 24 | 41 |
| 1J746-20-16 | 1J748-20-16 | 25 | 1 | -16 | 25.4 | 1 11/16x12 | 101 | 71 | 25 | 50 |
| 1J746-20-20 | | 31 | 1 1/4 | -20 | 31.8 | 1 11/16x12 | 124 | 86 | 26 | 50 |
| | 1J748-20-20 | 31 | 1 1/4 | -20 | 31.8 | 1 11/16x12 | 130 | 82 | 27 | 50 |
| | 1J748-24-24 | 38 | 1 1/2 | -24 | 38.1 | 2x12 | 148 | 110 | 40 | 60 |

Approved **fitting series** for hose types, depending on size: Also available in stainless steel. Details can be found in CAT 4400.1/UK

46 or **48** 441 | 461LT | 462 | 462TC | 462ST | 629PU | 692PU Twin

46 463 | 492 | 492ST | 492TC | 692 | 692Twin | 692TC | BCH1

48 301SN | 304 | 387 | 387ST | 387TC | 421RH | 421SN | 426 | 421TC | 436 | 441RH | 462PU | 462PU Twin | BCH2 | HT2 | ...

471TC | 477 | 477ST | 477TC | 477RH | 487 | 487ST | 487TC | 493 | 787 | 787TC | 787ST | 797 | 797TC | 797ST | 811 | 881



J9 Female ORFS – Swivel 90° Elbow – Short Drop

ISO 12151-1 – SWES
SAE J516 – ORFS 90°

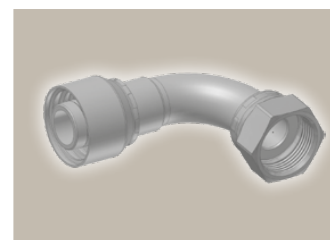
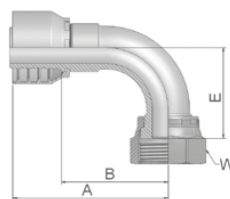

| Part Number | | Hose I.D. | | | | Thread | A | B | E | W |
|-------------|-------------|-----------|-------|------|------|------------|-----|-----|----|----|
| 46 series | 48 series | DN | Inch | Size | mm | UNF | mm | mm | mm | mm |
| 1J946-4-4 | 1J948-4-4 | 6 | 1/4 | -4 | 6.4 | 9/16x18 | 52 | 29 | 21 | 17 |
| 1J946-6-4 | 1J948-6-4 | 6 | 1/4 | -4 | 6.4 | 11/16x16 | 51 | 27 | 23 | 22 |
| | 1J948-8-4 | 6 | 1/4 | -4 | 6.4 | 13/16x16 | 50 | 26 | 29 | 24 |
| 1J946-6-5 | 1J948-6-5 | 8 | 5/16 | -5 | 7.9 | 11/16x16 | 53 | 29 | 23 | 22 |
| 1J946-4-6 | 1J948-4-6 | 10 | 3/8 | -6 | 9.5 | 9/16x18 | 47 | 24 | 21 | 17 |
| 1J946-6-6 | 1J948-6-6 | 10 | 3/8 | -6 | 9.5 | 11/16x16 | 52 | 29 | 23 | 22 |
| 1J946-8-6 | 1J948-8-6 | 10 | 3/8 | -6 | 9.5 | 13/16x16 | 53 | 30 | 29 | 24 |
| 1J946-6-8 | 1J948-6-8 | 12 | 1/2 | -8 | 12.7 | 11/16x16 | 53 | 29 | 23 | 22 |
| 1J946-8-8 | 1J948-8-8 | 12 | 1/2 | -8 | 12.7 | 13/16x16 | 55 | 32 | 29 | 24 |
| 1J946-10-8 | 1J948-10-8 | 12 | 1/2 | -8 | 12.7 | 1x14 | 66 | 42 | 32 | 30 |
| 1J946-12-8 | 1J948-12-8 | 12 | 1/2 | -8 | 12.7 | 1 3/16x12 | 58 | 34 | 48 | 36 |
| 1J946-10-10 | 1J948-10-10 | 16 | 5/8 | -10 | 15.9 | 1x14 | 65 | 39 | 32 | 30 |
| 1J946-12-10 | 1J948-12-10 | 16 | 5/8 | -10 | 15.9 | 1 3/16x12 | 71 | 45 | 48 | 36 |
| 1J946-10-12 | 1J948-10-12 | 19 | 3/4 | -12 | 19.1 | 1x14 | 69 | 43 | 32 | 30 |
| 1J946-12-12 | 1J948-12-12 | 19 | 3/4 | -12 | 19.1 | 1 3/16x12 | 80 | 54 | 48 | 36 |
| 1J946-16-12 | | 19 | 3/4 | -12 | 19.1 | 1 7/16x12 | 88 | 62 | 56 | 41 |
| 1J946-12-16 | | 25 | 1 | -16 | 25.4 | 1 3/16x12 | 88 | 58 | 48 | 36 |
| | 1J948-12-16 | 25 | 1 | -16 | 25.4 | 1 3/16 12 | 88 | 58 | 48 | 36 |
| 1J946-16-16 | 1J948-16-16 | 25 | 1 | -16 | 25.4 | 1 7/16x12 | 98 | 68 | 56 | 41 |
| 1J946-20-16 | 1J948-20-16 | 25 | 1 | -16 | 25.4 | 1 11/16x12 | 104 | 74 | 64 | 50 |
| 1J946-20-20 | | 31 | 1 1/4 | -20 | 31.8 | 1 11/16x12 | 124 | 86 | 64 | 50 |
| | 1J948-20-20 | 31 | 1 1/4 | -20 | 31.8 | 1 11/16x12 | 129 | 82 | 64 | 50 |
| | 1J948-24-24 | 38 | 1 1/2 | -24 | 38.1 | 2x12 | 140 | 102 | 82 | 60 |

46/48 Series

Approved **fitting series** for hose types, depending on size: Also available in stainless steel. Details can be found in CAT 4400.1/UK

46 or **48** 441 461LT 462 462TC 462ST 629PU 692PU Twin

46 463 492 492ST 492TC 692 692Twin 692TC BCH1

48 301SN 304 387 387ST 387TC 421RH 421SN 426 421TC 436 441RH 462PU 462PU Twin BCH2 HT2 ...

471TC 477 477ST 477TC 477RH 487 487ST 487TC 493 787 787TC 787ST 797 797TC 797ST 811 881

J1 Female ORFS – Swivel 90° Elbow – Long Drop

ISO 12151-1 – SWEL
SAE J 516 – ORFS 90° L

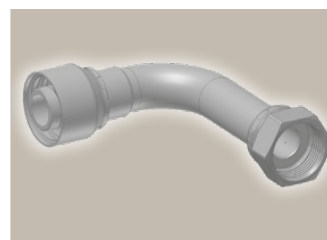

| Part Number | | Hose I.D. | | | | Thread | A | B | E | W |
|-------------|-------------|-----------|------|------|------|-----------|----|----|-----|----|
| 46 series | 48 series | DN | Inch | Size | mm | UNF | mm | mm | mm | mm |
| 1J146-4-4 | 1J148-4-4 | 6 | 1/4 | -4 | 6.4 | 9/16x18 | 58 | 35 | 46 | 17 |
| | 1J148-6-4 | 6 | 1/4 | -4 | 6.4 | 11/16x16 | 59 | 36 | 54 | 22 |
| 1J146-6-6 | 1J148-6-6 | 10 | 3/8 | -6 | 9.5 | 11/16x16 | 58 | 35 | 54 | 22 |
| 1J146-8-6 | 1J148-8-6 | 10 | 3/8 | -6 | 9.5 | 13/16x16 | 59 | 37 | 64 | 24 |
| 1J146-8-8 | 1J148-8-8 | 12 | 1/2 | -8 | 12.7 | 13/16x16 | 61 | 37 | 64 | 24 |
| | 1J148-10-8 | 12 | 1/2 | -8 | 12.7 | 1x14 | 66 | 42 | 70 | 30 |
| 1J146-10-10 | 1J148-10-10 | 16 | 5/8 | -10 | 15.9 | 1x14 | 65 | 39 | 70 | 30 |
| 1J146-12-12 | 1J148-12-12 | 19 | 3/4 | -12 | 19.1 | 1 3/16x12 | 80 | 54 | 96 | 36 |
| | 1J148-16-16 | 25 | 1 | -16 | 25.4 | 1 7/16x12 | 98 | 68 | 114 | 41 |

J5 Female ORFS – Swivel 90° Elbow – Medium Drop

ISO 12151-1 – SWEM – ORFS 90° M

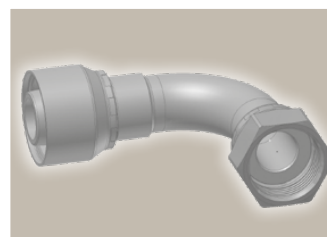
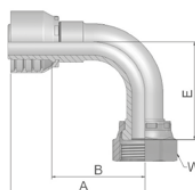

| Part Number | | Hose I.D. | | | | Thread | A | B | E | W |
|-------------|-------------|-----------|------|------|------|-----------|----|----|----|----|
| 46 series | 48 series | DN | Inch | Size | mm | UNF | mm | mm | mm | mm |
| 1J546-4-4 | 1J548-4-4 | 6 | 1/4 | -4 | 6.4 | 9/16x18 | 59 | 35 | 32 | 17 |
| 1J546-6-4 | 1J548-6-4 | 6 | 1/4 | -4 | 6.4 | 11/16x16 | 62 | 39 | 38 | 22 |
| 1J546-6-6 | 1J548-6-6 | 10 | 3/8 | -6 | 9.5 | 11/16x16 | 58 | 35 | 38 | 22 |
| 1J546-8-6 | 1J548-8-6 | 10 | 3/8 | -6 | 9.5 | 13/16x16 | 60 | 37 | 41 | 24 |
| 1J546-8-8 | 1J548-8-8 | 12 | 1/2 | -8 | 12.7 | 13/16x16 | 60 | 37 | 41 | 24 |
| 1J546-10-10 | 1J548-10-10 | 16 | 5/8 | -10 | 15.9 | 1x14 | 65 | 39 | 47 | 30 |
| 1J546-12-12 | 1J548-12-12 | 19 | 3/4 | -12 | 19.1 | 1 3/16x12 | 80 | 54 | 58 | 36 |

Approved **fitting series** for hose types, depending on size: Also available in stainless steel. Details can be found in CAT 4400.1/UK

46 or **48** 441 461LT 462 462TC 462ST 629PU 692PU Twin

46 463 492 492ST 492TC 692 692Twin 692TC BCH1

48 301SN 304 387 387ST 387TC 421RH 421SN 426 421TC 436 441RH 462PU 462PU Twin BCH2 HT2 ...

471TC 477 477ST 477TC 477RH 487 487ST 487TC 493 787 787TC 787ST 797 797TC 797ST 811 881

JM **ORFS Male**
ISO 12151-1-S – SAE J516

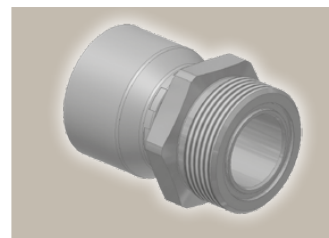
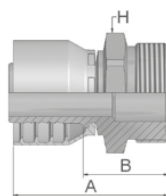

| Part Number | | Hose I.D. | | | | Thread | A | B | H |
|-------------|-------------|-----------|-------|------|------|------------|----|----|----|
| 46 series | 48 series | DN | Inch | Size | mm | UNF | mm | mm | mm |
| 1JM46-4-4 | | 6 | 1/4 | -4 | 6.4 | 9/16x18 | 46 | 22 | 17 |
| | 1JM48-4-4 | 6 | 1/4 | -4 | 6.4 | 9/16x18 | 44 | 22 | 17 |
| 1JM46-6-4 | | 6 | 1/4 | -4 | 6.4 | 11/16x16 | 48 | 24 | 19 |
| | 1JM48-6-4 | 6 | 1/4 | -4 | 6.4 | 11/16x16 | 46 | 24 | 19 |
| 1JM46-6-5 | 1JM48-6-5 | 8 | 5/16 | -5 | 7.9 | 11/16x16 | 53 | 26 | 19 |
| 1JM46-6-6 | 1JM48-6-6 | 10 | 3/8 | -6 | 9.5 | 11/16x16 | 47 | 24 | 19 |
| 1JM46-8-6 | 1JM48-8-6 | 10 | 3/8 | -6 | 9.5 | 13/16x16 | 50 | 27 | 22 |
| 1JM46-8-8 | 1JM48-8-8 | 12 | 1/2 | -8 | 12.7 | 13/16x16 | 51 | 27 | 22 |
| 1JM46-10-8 | 1JM48-10-8 | 12 | 1/2 | -8 | 12.7 | 1x14 | 55 | 32 | 27 |
| 1JM46-10-10 | 1JM48-10-10 | 16 | 5/8 | -10 | 15.9 | 1x14 | 57 | 32 | 27 |
| 1JM46-12-10 | 1JM48-12-10 | 16 | 5/8 | -10 | 15.9 | 1 3/16x12 | 59 | 34 | 32 |
| 1JM46-12-12 | 1JM48-12-12 | 19 | 3/4 | -12 | 19.1 | 1 3/16x12 | 60 | 34 | 32 |
| 1JM46-16-12 | 1JM48-16-12 | 19 | 3/4 | -12 | 19.1 | 1 7/16x12 | 64 | 38 | 41 |
| 1JM46-16-16 | 1JM48-16-16 | 25 | 1 | -16 | 25.4 | 1 7/16x12 | 67 | 37 | 41 |
| 1JM46-20-16 | 1JM48-20-16 | 25 | 1 | -16 | 25.4 | 1 11/16x12 | 66 | 36 | 46 |
| | 1JM48-20-20 | 31 | 1 1/4 | -20 | 31.8 | 1 11/16x12 | 85 | 37 | 46 |

To select corresponding O-ring see section Eb.

JD **Male ORFS**
Bulkhead with Locknut
Straight (with O-ring)
ISO 12151-1 – SAE J516

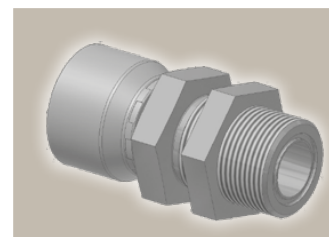
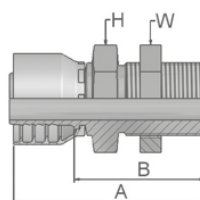

| Part Number | | Hose I.D. | | | | Thread | A | B | H | W |
|-------------|-------------|-----------|------|------|------|-----------|----|----|----|----|
| 46 series | 48 series | DN | Inch | Size | mm | UNF | mm | mm | mm | mm |
| 1JD46-4-4 | 1JD48-4-4 | 6 | 1/4 | -4 | 6.4 | 9/16x18 | 72 | 48 | 22 | 22 |
| 1JD46-6-6 | 1JD48-6-6 | 10 | 3/8 | -6 | 9.5 | 11/16x16 | 73 | 51 | 27 | 27 |
| 1JD46-8-8 | 1JD48-8-8 | 12 | 1/2 | -8 | 12.7 | 13/16x16 | 79 | 56 | 30 | 30 |
| 1JD46-10-10 | 1JD48-10-10 | 16 | 5/8 | -10 | 15.9 | 1x14 | 86 | 60 | 32 | 36 |
| 1JD46-12-12 | 1JD48-12-12 | 19 | 3/4 | -12 | 19.1 | 1 3/16x12 | 88 | 63 | 36 | 38 |
| | 1JD48-16-16 | 25 | 1 | -16 | 25.4 | 1 7/16x12 | 94 | 64 | 46 | 46 |

To select corresponding O-ring see section Eb.

Approved **fitting series** for hose types, depending on size: Also available in stainless steel. Details can be found in CAT 4400.1/UK

46 or **48** 441 461LT 462 462TC 462ST 629PU 692PU Twin

46 463 492 492ST 492TC 692 692Twin 692TC BCH1

48 301SN 304 387 387ST 387TC 421RH 421SN 426 421TC 436 441RH 462PU 462PU Twin BCH2 HT2 ...

471TC 477 477ST 477TC 477RH 487 487ST 487TC 493 787 787TC 787ST 797 797TC 797ST 811 881

FU Female BSP Parallel Pipe Swivel – Straight (30° Flare)

ISO 228-1 – JIS B8363 – GUI

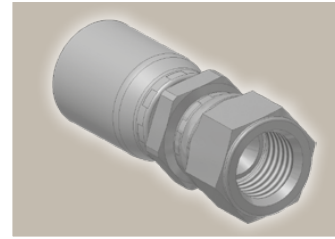
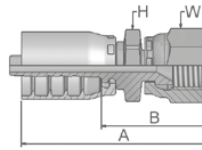

| Part Number | | Hose I.D. | | | | Thread | A | B | H | W |
|-------------|-------------|-----------|------|------|------|--------|----|----|----|----|
| 46 series | 48 series | DN | Inch | Size | mm | BSP | mm | mm | mm | mm |
| 1FU46-4-4 | 1FU48-4-4 | 6 | 1/4 | -4 | 6.4 | 1/4x19 | 50 | 32 | 19 | 19 |
| 1FU46-6-6 | 1FU48-6-6 | 10 | 3/8 | -6 | 9.5 | 3/8x19 | 58 | 35 | 24 | 22 |
| 1FU46-12-12 | 1FU48-12-12 | 19 | 3/4 | -12 | 19.1 | 3/4x14 | 71 | 45 | 36 | 36 |
| 1FU46-16-16 | 1FU48-16-16 | 25 | 1 | -16 | 25.4 | 1x11 | 76 | 46 | 41 | 41 |

GU Female BSP Parallel Pipe Swivel – Straight (60° Cone)

ISO 228-1 – JIS B8363 – GUO

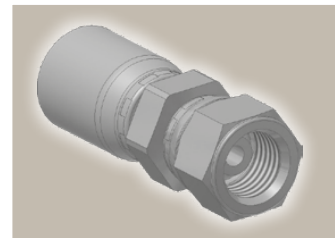
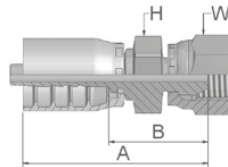

| Part Number | | Hose I.D. | | | | Thread | A | B | H | W |
|-------------|-----------|-----------|------|------|------|--------|----|----|----|----|
| 46 series | 48 series | DN | Inch | Size | mm | BSP | mm | mm | mm | mm |
| 1GU46-4-4 | 1GU48-4-4 | 6 | 1/4 | -4 | 6.4 | 1/4x19 | 55 | 33 | 19 | 19 |
| 1GU46-6-6 | 1GU48-6-6 | 10 | 3/8 | -6 | 9.5 | 3/8x19 | 58 | 35 | 22 | 22 |
| 1GU46-8-8 | 1GU48-8-8 | 12 | 1/2 | -8 | 12.7 | 1/2x14 | 55 | 32 | 27 | 27 |

Approved **fitting series** for hose types, depending on size: Also available in stainless steel. Details can be found in CAT 4400.1/UK

| | | | | | | | | | | | | | | | | | |
|------------------------|-------|-------|-------|-------|-------|---------|------------|-------|-------|-----|-------|-------|------------|-------|-------|-----|-----|
| 46 or 48 | 441 | 461LT | 462 | 462TC | 462ST | 629PU | 692PU Twin | | | | | | | | | | |
| 46 | 463 | 492 | 492ST | 492TC | 692 | 692Twin | 692TC | BCH1 | | | | | | | | | |
| 48 | 301SN | 304 | 387 | 387ST | 387TC | 421RH | 421SN | 426 | 421TC | 436 | 441RH | 462PU | 462PU Twin | BCH2 | HT2 | ... | |
| | 471TC | 477 | 477ST | 477TC | 477RH | 487 | 487ST | 487TC | 493 | 787 | 787TC | 787ST | 797 | 797TC | 797ST | 811 | 881 |

Medium Pressure
JIS

Parkrimp No-Skive Fittings
46/48 Series

MZ Female Metric – Swivel 90° Elbow (30° Flare)

JIS B8363

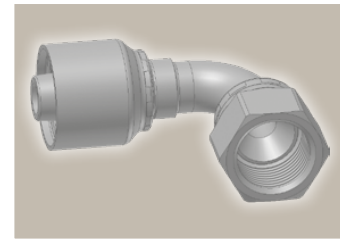
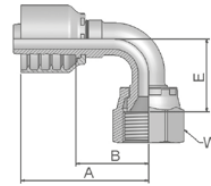

| Part Number | | Hose I.D. | | | | Thread | A | B | E | W |
|-------------|-----------|---------------|------|------|------|------------|----|----|----|-------|
| 46 series | 48 series | DN | Inch | Size | mm | metric | mm | mm | mm | mm |
| 1MZ46-4-4 | 1MZ48-4-4 | 6 | 1/4 | -4 | 6.4 | M14x1.5 | 48 | 24 | 23 | 19 |
| 1MZ46-6-6 | 1MZ48-6-6 | 10 | 3/8 | -6 | 9.5 | M18x1.5 | 51 | 28 | 29 | 24 |
| 1MZ46-8-8 | 1MZ48-8-8 | 12 | 1/2 | -8 | 12.7 | M22x1.5 | 55 | 31 | 31 | 27 |

46/48 Series

Approved **fitting series** for hose types, depending on size: Also available in stainless steel. Details can be found in CAT 4400.1/UK

| | | | | | | | | | | | | | | | | | |
|------------------------|-------|-------|-------|-------|-------|---------|------------|-------|-------|-----|-------|-------|------------|-------|-------|-----|-----|
| 46 or 48 | 441 | 461LT | 462 | 462TC | 462ST | 629PU | 692PU Twin | | | | | | | | | | |
| 46 | 463 | 492 | 492ST | 492TC | 692 | 692Twin | 692TC | BCH1 | | | | | | | | | |
| 48 | 301SN | 304 | 387 | 387ST | 387TC | 421RH | 421SN | 426 | 421TC | 436 | 441RH | 462PU | 462PU Twin | BCH2 | HT2 | ... | |
| | 471TC | 477 | 477ST | 477TC | 477RH | 487 | 487ST | 487TC | 493 | 787 | 787TC | 787ST | 797 | 797TC | 797ST | 811 | 881 |



Cc-37

Catalogue 4400/UK

CW Power Cleaner Connection

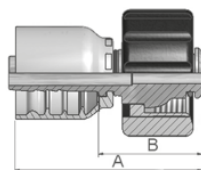

| Part Number | | Hose I.D. | | | | Thread | Tube | A | B |
|-------------|------------|-----------|------|------|------|---------|------------|----|----|
| 46 series | 48 series | DN | Inch | Size | mm | metric | O.D. mm | mm | mm |
| 1CW46-15-4 | 1CW48-15-4 | 6 | 1/4 | -4 | 6.4 | M22x1.5 | 15 | 53 | 29 |
| 1CW46-15-5 | 1CW48-15-5 | 8 | 5/16 | -5 | 7.9 | M22x1.5 | 15 | 53 | 29 |
| 1CW46-15-6 | 1CW48-15-6 | 10 | 3/8 | -6 | 9.5 | M22x1.5 | 15 | 52 | 29 |
| 1CW46-15-8 | 1CW48-15-8 | 12 | 1/2 | -8 | 12.7 | M22x1.5 | 15 | 53 | 29 |

Rubber hand grip Part-No. WKS-X-XXX in black or blue please find on page Eb-17.

NW Female Kärcher Metric Cleaning Hose Fitting Swivel – Straight

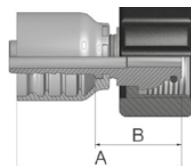

| Part Number | | Hose I.D. | | | | Thread | A | B |
|-------------|------------|-----------|------|------|-----|---------|----|----|
| 46 series | 48 series | DN | Inch | Size | mm | metric | mm | mm |
| 1NW46-15-4 | 1NW48-15-4 | 6 | 1/4 | -4 | 6.4 | M22x1.5 | 52 | 29 |
| 1NW46-15-5 | 1NW48-15-5 | 8 | 5/16 | -5 | 7.9 | M22x1.5 | 52 | 29 |
| 1NW46-15-6 | 1NW48-15-6 | 10 | 3/8 | -6 | 9.5 | M22x1.5 | 48 | 25 |

Rubber hand grip Part-No. WKS-X-XXX in black or blue please find on page Eb-17.

Approved **fitting series** for hose types, depending on size: Also available in stainless steel. Details can be found in CAT 4400.1/UK

46 or **48** 441 461LT 462 462TC 462ST 629PU 692PU Twin

46 463 492 492ST 492TC 692 692Twin 692TC BCH1

48 301SN 304 387 387ST 387TC 421RH 421SN 426 421TC 436 441RH 462PU 462PU Twin BCH2 HT2 ...

471TC 477 477ST 477TC 477RH 487 487ST 487TC 493 787 787TC 787ST 797 797TC 797ST 811 881

Medium Pressure
High Pressure Cleaning

Parkrimp No-Skive Fittings
46/48 Series

PW **Male Kärcher
Metric Cleaning Hose Fitting
Rigid – Straight**

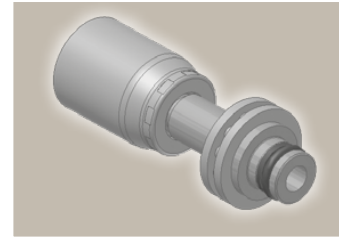
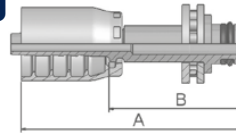

| Part Number | | Hose I.D. | | | | Tube | A | B |
|-------------|------------|---------------|------|------|-----|------------|----|----|
| 46 series | 48 series | DN | Inch | Size | mm | O.D. mm | mm | mm |
| 1PW46-10-4 | 1PW48-10-4 | 6 | 1/4 | -4 | 6.4 | 10 | 60 | 36 |
| 1PW46-11-4 | 1PW48-11-4 | 6 | 1/4 | -4 | 6.4 | 11 | 60 | 37 |
| 1PW46-10-5 | 1PW48-10-5 | 8 | 5/16 | -5 | 7.9 | 10 | 60 | 36 |
| 1PW46-11-5 | 1PW48-11-5 | 8 | 5/16 | -5 | 7.9 | 11 | 61 | 37 |
| 1PW46-10-6 | 1PW48-10-6 | 10 | 3/8 | -6 | 9.5 | 10 | 60 | 37 |

Rubber hand grip Part-No. WKS-X-XXX in black or blue please find on page Eb-17.

1PWxx-**11**-x = with ball bearing as shown above

1PWxx-**10**-x = without ball bearing

46/48 Series

Approved **fitting series** for hose types, depending on size: Also available in stainless steel. Details can be found in CAT 4400.1/UK

| | | | | | | | | | | | | | | | | | |
|------------------------|-------|-------|-------|-------|-------|---------|------------|-------|-------|-----|-------|-------|------------|-------|-------|-----|-----|
| 46 or 48 | 441 | 461LT | 462 | 462TC | 462ST | 629PU | 692PU Twin | | | | | | | | | | |
| 46 | 463 | 492 | 492ST | 492TC | 692 | 692Twin | 692TC BCH1 | | | | | | | | | | |
| 48 | 301SN | 304 | 387 | 387ST | 387TC | 421RH | 421SN | 426 | 421TC | 436 | 441RH | 462PU | 462PU Twin | BCH2 | HT2 | ... | |
| | 471TC | 477 | 477ST | 477TC | 477RH | 487 | 487ST | 487TC | 493 | 787 | 787TC | 787ST | 797 | 797TC | 797ST | 811 | 881 |



XU Female Metric – Swivel Straight (30° Flare)

JIS B8363

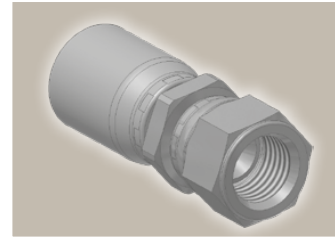
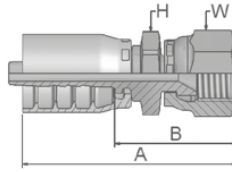

| Part Number | | Hose I.D. | | | | Thread metric | A | B | H | W |
|-------------|-------------|-----------|------|------|------|---------------|----|----|----|----|
| 46 series | 48 series | DN | Inch | Size | mm | | mm | mm | mm | mm |
| | 1XU48-10-10 | 16 | 5/8 | -10 | 15.9 | M24x1.5 | 69 | 44 | 30 | 32 |
| | 1XU48-12-12 | 19 | 3/4 | -12 | 19.1 | M30x1.5 | 73 | 47 | 32 | 36 |

Approved **fitting series** for hose types, depending on size: Also available in stainless steel. Details can be found in CAT 4400.1/UK

| | | | | | | | | | | | | | | | | | |
|------------------------|-------|-------|-------|-------|-------|---------|------------|-------|-------|-----|-------|-------|------------|-------|-------|-----|-----|
| 46 or 48 | 441 | 461LT | 462 | 462TC | 462ST | 629PU | 692PU Twin | | | | | | | | | | |
| 46 | 463 | 492 | 492ST | 492TC | 692 | 692Twin | 692TC | BCH1 | | | | | | | | | |
| 48 | 301SN | 304 | 387 | 387ST | 387TC | 421RH | 421SN | 426 | 421TC | 436 | 441RH | 462PU | 462PU Twin | BCH2 | HT2 | ... | |
| | 471TC | 477 | 477ST | 477TC | 477RH | 487 | 487ST | 487TC | 493 | 787 | 787TC | 787ST | 797 | 797TC | 797ST | 811 | 881 |



EN UPTC – Male Straight

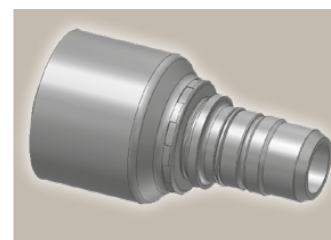
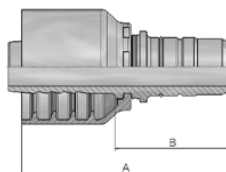

| Part Number | | Hose I.D. | | | | Tube | A | B |
|-------------|-------------|---------------|------|------|------|------------|----|----|
| 46 series | 48 series | DN | Inch | Size | mm | O.D. mm | mm | mm |
| 1EN46-8-4 | 1EN48-8-4 | 6 | 1/4 | -4 | 6,4 | 8 | 49 | 26 |
| 1EN46-10-5 | 1EN48-10-5 | 8 | 5/16 | -5 | 7,9 | 10 | 50 | 26 |
| 1EN46-12-6 | 1EN48-12-6 | 10 | 3/8 | -6 | 9,5 | 12 | 50 | 27 |
| 1EN46-15-8 | 1EN48-15-8 | 12 | 1/2 | -8 | 12,7 | 15 | 53 | 29 |
| 1EN46-18-10 | 1EN48-18-10 | 16 | 5/8 | -10 | 15,9 | 18 | 56 | 31 |
| 1EN46-22-12 | 1EN48-22-12 | 19 | 3/4 | -12 | 19,1 | 22 | 57 | 32 |

EU UPTC – Male 45° Elbow

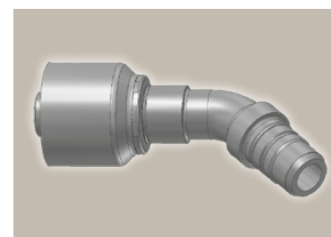
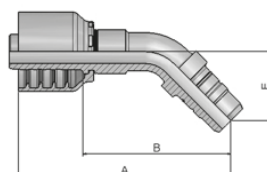

46/48 Series

| Part Number | | Hose I.D. | | | | Tube | A | B | E |
|-------------|-------------|---------------|------|------|------|------------|----|----|----|
| 46 series | 48 series | DN | Inch | Size | mm | O.D. mm | mm | mm | mm |
| 1EU46-8-4 | 1EU48-8-4 | 6 | 1/4 | -4 | 6,4 | 8 | 66 | 43 | 23 |
| 1EU46-10-5 | 1EU48-10-5 | 8 | 5/16 | -5 | 7,9 | 10 | 68 | 45 | 23 |
| 1EU46-12-6 | 1EU48-12-6 | 10 | 3/8 | -6 | 9,5 | 12 | 71 | 48 | 23 |
| 1EU46-15-8 | 1EU48-15-8 | 12 | 1/2 | -8 | 12,7 | 15 | 78 | 54 | 25 |
| 1EU46-18-10 | 1EU48-18-10 | 16 | 5/8 | -10 | 15,9 | 18 | 84 | 59 | 32 |
| 1EU46-22-12 | 1EU48-22-12 | 19 | 3/4 | -12 | 19,1 | 22 | 95 | 69 | 33 |

Approved **fitting series** for hose types, depending on size:

46 or **48** 441 | 461LT | 462 | 462TC | 462ST | 629PU | 692PU Twin

46 463 | 492 | 492ST | 492TC | 692 | 692Twin | 692TC | BCH1

48 301SN | 304 | 387 | 387ST | 387TC | 421RH | 421SN | 426 | 421TC | 436 | 441RH | 462PU | 462PU Twin | BCH2 | HT2 | ...

471TC | 477 | 477ST | 477TC | 477RH | 487 | 487ST | 487TC | 493 | 787 | 787TC | 787ST | 797 | 797TC | 797ST | 811 | 881

Medium Pressure
UPTC

Parkrimp No-Skive Fittings
46/48 Series

ET UPTC – Male 90° Elbow

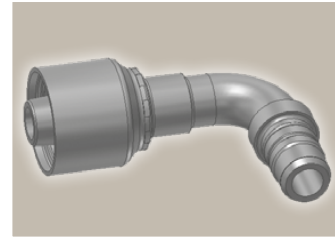
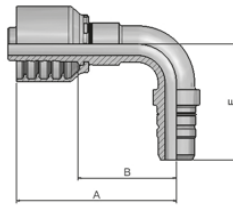

| Part Number | | Hose I.D. | | | | Tube | A | B | E |
|-------------|-------------|-----------|------|------|------|------------|----|----|----|
| 46 series | 48 series | DN | Inch | Size | mm | O.D. mm | mm | mm | mm |
| 1ET46-8-4 | 1ET48-8-4 | 6 | 1/4 | -4 | 6.4 | 8 | 59 | 36 | 39 |
| 1ET46-10-5 | 1ET48-10-5 | 8 | 5/16 | -5 | 7.9 | 10 | 58 | 35 | 39 |
| 1ET46-12-6 | 1ET48-12-6 | 10 | 3/8 | -6 | 9.5 | 12 | 57 | 34 | 40 |
| 1ET46-15-8 | 1ET48-15-8 | 12 | 1/2 | -8 | 12.7 | 15 | 61 | 38 | 45 |
| 1ET46-18-10 | 1ET48-18-10 | 16 | 5/8 | -10 | 15.9 | 18 | 65 | 39 | 57 |
| 1ET46-22-12 | 1ET48-22-12 | 19 | 3/4 | -12 | 19.1 | 22 | 80 | 54 | 64 |

Approved **fitting series** for hose types, depending on size:

| | | | | | | | | | | | | | | | | | |
|------------------------|-------|-------|-------|-------|-------|---------|------------|-------|-------|-----|-------|-------|------------|-------|-------|-----|-----|
| 46 or 48 | 441 | 461LT | 462 | 462TC | 462ST | 629PU | 692PU Twin | | | | | | | | | | |
| 46 | 463 | 492 | 492ST | 492TC | 692 | 692Twin | 692TC BCH1 | | | | | | | | | | |
| 48 | 301SN | 304 | 387 | 387ST | 387TC | 421RH | 421SN | 426 | 421TC | 436 | 441RH | 462PU | 462PU Twin | BCH2 | HT2 | ... | |
| | 471TC | 477 | 477ST | 477TC | 477RH | 487 | 487ST | 487TC | 493 | 787 | 787TC | 787ST | 797 | 797TC | 797ST | 811 | 881 |



Cc-42

Catalogue 4400/UK

Shell

Page Cd-1

10048

Cd-1

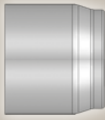

No-Skive shell

SAE

Page Cd-1

01

Cd-1

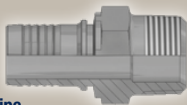

Male NPTF Pipe
Rigid – Straight
SAE J476A / J516 – AGN

Flange

Page Cd-2

15

Cd-2

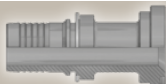

ISO 6162-1-Flange
Straight
ISO 12151-3-S-L – SFL
(21.0 MPa/ 3000 psi)

17

Cd-2

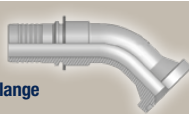

ISO 6162-1 Flange
45° Elbow
ISO 12151-3 – E45 – L – SFL 45°
(21.0 MPa/ 3000 psi)

19

Cd-2



ISO 6162-1-Flange
90° Elbow
ISO 12151-3 – E – L – SFL 90°
(21.0 MPa/ 3000 psi)

Crimp Diameters please find on www.parker.com/crimpsource-euro

Medium Pressure
Shell / SAE

Parkrimp No-Skive Fittings
2piece – Series 48

10048 No-Skive shell

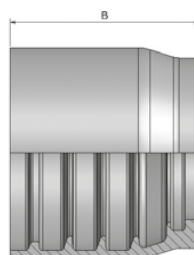

Only for use with adjustable crimpers.

| Part Number | Hose I.D. | | | | B mm |
|-------------|---------------|-------|------|------|---------|
| | DN | Inch | Size | mm | |
| 10048-40 | 63 | 2 1/2 | -40 | 63.5 | 67 |
| 10048-48 | 76 | 3 | -48 | 76.2 | 75 |

01 Male NPTF Pipe Rigid – Straight

SAE J476A / J516 – AGN

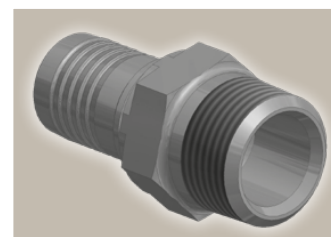
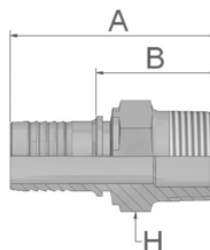

2piece – Series 48

| Part Number | Hose I.D. | | | | Thread NPTF | A mm | B mm | H mm |
|-------------|---------------|-------|------|------|--------------------|---------|---------|-------------|
| | DN | Inch | Size | mm | | | | |
| K0147-48-40 | 63 | 2 1/2 | -40 | 63.5 | 3-8 | 135 | 73 | 95 |
| K0147-48-48 | 76 | 3 | -48 | 76.2 | 3-8 | 143 | 73 | 95 |

Approved **fitting series** for hose types, depending on size:

48 187 187TC 187ST 462TC



Cd-1

Catalogue 4400/UK

Medium Pressure
Flange

Parkrimp No-Skive Fittings
2piece – Series 48

15 ISO 6162-1-Flange Straight

ISO 12151-3-S-L – SFL
(21.0 MPa/ 3000 psi)

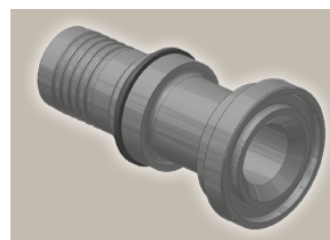
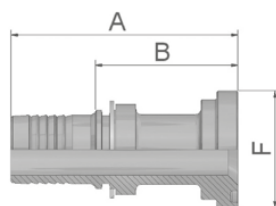

| Part Number | Hose I.D. | | | | Flange Inch | A mm | B mm | F mm |
|-------------|-----------|-------|------|------|----------------|---------|---------|---------|
| | DN | Inch | Size | mm | | | | |
| K1547-40-40 | 63 | 2 1/2 | -40 | 63.5 | 2 1/2 | 127 | 65 | 84 |
| K1547-48-40 | 63 | 2 1/2 | -40 | 63.5 | 3 | 137 | 75 | 102 |
| K1547-48-48 | 76 | 3 | -48 | 76.2 | 3 | 155 | 85.5 | 102 |

To select corresponding half-flange and O-ring see section Eb.

17 ISO 6162-1 Flange 45° Elbow

ISO 12151-3 – E45 – L – SFL 45°
(21.0 MPa/ 3000 psi)

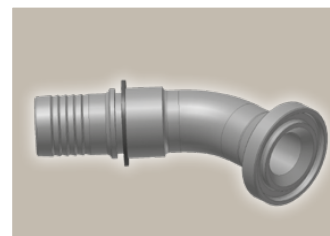
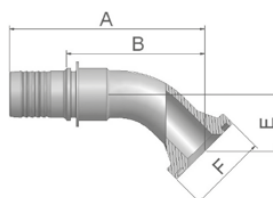

| Part Number | Hose I.D. | | | | Flange Inch | A mm | B mm | E mm | F mm |
|-------------|-----------|-------|------|------|----------------|---------|---------|---------|---------|
| | DN | Inch | Size | mm | | | | | |
| K1747-40-40 | 63 | 2 1/2 | -40 | 63.5 | 2 1/2 | 179 | 118 | 47 | 84 |
| K1747-48-48 | 76 | 3 | -48 | 76.2 | 3 | 204 | 134 | 53 | 102 |

To select corresponding half-flange and O-ring see section Eb.

19 ISO 6162-1-Flange 90° Elbow

ISO 12151-3 – E – L – SFL 90°
(21.0 MPa/ 3000 psi)

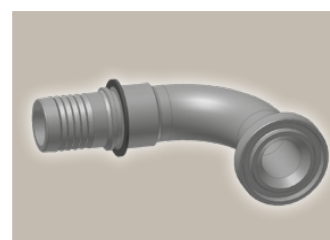
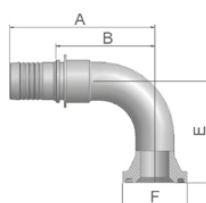

| Part Number | Hose I.D. | | | | Flange Inch | A mm | B mm | E mm | F mm |
|-------------|-----------|-------|------|------|----------------|---------|---------|---------|---------|
| | DN | Inch | Size | mm | | | | | |
| K1947-40-40 | 63 | 2 1/2 | -40 | 63.5 | 2 1/2 | 177 | 116 | 111 | 84 |
| K1947-48-48 | 76 | 3 | -48 | 76.2 | 3 | 206 | 136 | 131 | 102 |

To select corresponding half-flange and O-ring see section Eb.

Approved **fitting series** for hose types, depending on size:

48 187 187TC 187ST 462TC



Cd-2

Catalogue 4400/UK

Shell

Page Ce-1

100IF

Ce-1



No-Skive shell

Flange

Page Ce-2 – Ce-3

15

Ce-2



**ISO 6162-1-Flange
Straight**

ISO 12151-3-S-L – SFL
(21.0 MPa/ 3000 psi)

17

Ce-2



**ISO 6162-1 Flange
45° Elbow**

ISO 12151-3 – E45 – L – SFL 45°
(21.0 MPa/ 3000 psi)

19

Ce-3



**ISO 6162-1-Flange
90° Elbow**

ISO 12151-3 – E – L – SFL 90°
(21.0 MPa/ 3000 psi)

Crimp Diameters please find on www.parker.com/crimpsource-euro

Medium Pressure
Shell

Parkrimp No-Skive Fittings
2piece – Series IF

100IF No-Skive shell



Only for use with
adjustable crimpers.

| Part Number |  Hose I.D. | | | | B mm |
|-------------|------------------------------------------------------------------------------------------------|-------|------|-------|---------|
| | DN | Inch | Size | mm | |
| 100IF-40 | 63 | 2 1/2 | -40 | 63.5 | 63 |
| 100IF-48 | 76 | 3 | -48 | 76.2 | 68 |
| 100IF-56 | 90 | 3 1/2 | -56 | 88.9 | 100 |
| 100IF-64 | 100 | 4 | -64 | 101.6 | 95 |
| 100IF-80 | 127 | 5 | -80 | 127.0 | 110 |
| 100IF-96 | 152 | 6 | -96 | 152.4 | 142 |

2piece – Series IF

Approved **fitting series** for hose types, depending on size:

 811 811S



Ce-1

Catalogue 4400/UK

15 ISO 6162-1-Flange Straight

ISO 12151-3-S-L – SFL
(21.0 MPa/ 3000 psi)

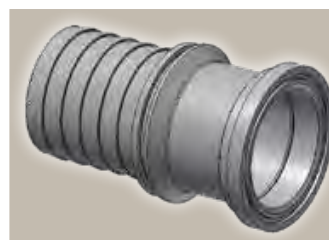
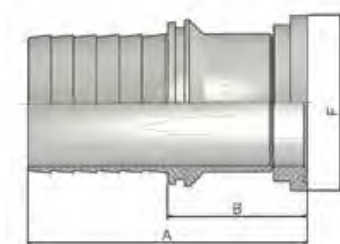

| Part Number | Hose I.D. | | | | Flange Inch | A mm | B mm | F mm |
|-------------|-----------|-------|------|-------|----------------|---------|---------|---------|
| | DN | Inch | Size | mm | | | | |
| K15IF-40-40 | 63 | 2 1/2 | -40 | 63.5 | 2 1/2 | 120 | 67 | 84 |
| K15IF-48-48 | 76 | 3 | -48 | 76.2 | 3 | 166 | 95 | 102 |
| K15IF-56-56 | 90 | 3 1/2 | -56 | 88.9 | 3 1/2 | 183 | 91 | 114 |
| K15IF-64-64 | 100 | 4 | -64 | 101.6 | 4 | 206 | 103 | 127 |
| K15IF-80-80 | 127 | 5 | -80 | 127.0 | 5 | 221 | 118 | 152 |
| K15IF-80-96 | 152 | 6 | -96 | 152.4 | 5 | 281 | 151 | 152 |

To select corresponding half-flange and O-ring see section Eb.

17 ISO 6162-1 Flange 45° Elbow

ISO 12151-3 – E45 – L – SFL 45°
(21.0 MPa/ 3000 psi)

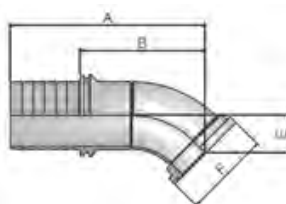

| Part Number | Hose I.D. | | | | Flange Inch | A mm | B mm | E mm | F mm |
|-------------|-----------|-------|------|-------|----------------|---------|---------|---------|---------|
| | DN | Inch | Size | mm | | | | | |
| K17IF-40-40 | 63 | 2 1/2 | -40 | 63.5 | 2 1/2 | 164 | 111 | 47 | 84 |
| K17IF-48-48 | 76 | 3 | -48 | 76.2 | 3 | 224 | 153 | 53 | 102 |
| K17IF-56-56 | 90 | 3 1/2 | -56 | 88.9 | 3 1/2 | 258 | 166 | 50 | 114 |
| K17IF-64-64 | 100 | 4 | -64 | 101.6 | 4 | 294 | 191 | 57 | 127 |
| K17IF-80-80 | 127 | 5 | -80 | 127.0 | 5 | 341 | 238 | 92 | 152 |
| K17IF-80-96 | 152 | 6 | -96 | 152.4 | 5 | 401 | 271 | 92 | 152 |

SAE flange halves see in section Eb.

Fittings with standard O-ring seals can be used for temperatures from -40 °C up to +105 °C.
O-rings see section Eb. Special O-rings are available on request.

Approved **fitting series** for hose types, depending on size:

811 811S



19 ISO 6162-1-Flange 90° Elbow

ISO 12151-3 – E- L – SFL 90°
(21.0 MPa/ 3000 psi)

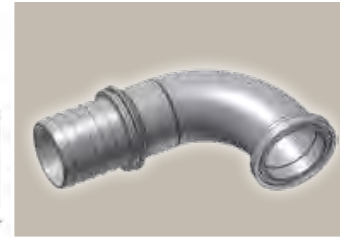
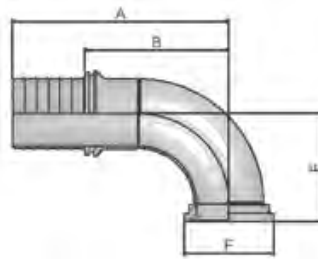

| Part Number | Hose I.D. | | | | Flange Inch | A mm | B mm | E mm | F mm |
|-------------|-----------|-------|------|-------|----------------|---------|---------|---------|---------|
| | DN | Inch | Size | mm | | | | | |
| K19IF-40-40 | 63 | 2 1/2 | -40 | 63.5 | 2 1/2 | 162 | 109 | 111 | 84 |
| K19IF-48-48 | 76 | 3 | -48 | 76.2 | 3 | 226 | 155 | 131 | 102 |
| K19IF-56-56 | 90 | 3 1/2 | -56 | 88.9 | 3 1/2 | 275 | 183 | 137 | 114 |
| K19IF-64-64 | 100 | 4 | -64 | 101.6 | 4 | 314 | 211 | 159 | 127 |
| K19IF-80-80 | 127 | 5 | -80 | 127.0 | 5 | 361 | 258 | 241 | 152 |
| K19IF-80-96 | 152 | 6 | -96 | 152.4 | 5 | 421 | 291 | 241 | 152 |

SAE flange halves see in section Eb.

Fittings with standard O-ring seals can be used for temperatures from -40 °C up to +105 °C.

O-rings see section Eb. Special O-rings are available on request.

2piece – Series IF

Approved **fitting series** for hose types, depending on size:

IF 811 811S





Hydraulic Hoses and Fittings

High Pressure



ENGINEERING YOUR SUCCESS.

High Pressure Hoses and Fittings

Three systems for heavy duty performers

Multispiral Parkrimp *No-Skive*

Crimpable with
Parkrimp System



Compact Spiral Interlock *No-Skive*

Crimpable with
Parkrimp System



ParLock Interlock Skive

Crimpable with
adjustable crimpers



Applications

The definitive hose range for all
high pressure applications



D-2

Crimper systems you can trust

Parkrimp crimpers for *No-Skive* one-piece fittings



KarryKrimp® 2



KarryKrimp® 2
Bench Mount



Parkrimp®

Adjustable crimpers for two-piece ParLock fittings



TH8E-530



TH 8E-380-CM



TH 8E-480-CM



Parkrimp *No-Skive*
one-piece fittings



ParLock
two-piece skive fittings

Good – Better – Best – engineered for your success.

New classification for easier hose and fitting selection

Good

“Good” hoses are cost-effective products – fully meeting the main parameters of the traditional international standards and exceeding them in particular requirements, such as service life, appearance, environmental aspects etc. (BCH braided hoses in combination with fitting series 16, 46, 48 in the medium pressure range and SX spiral hoses with fitting series 73 and 77).

Good High Pressure

SX35, SX42

Fitting Series



* MP (Multipack) only

Better

The category “Better” includes hose products which are exceeding the traditional international standards in the main parameters, such as working pressure, temperature, flexibility, impulse pressure resistance etc. These are the main qualities appreciated by the customers at the Parker well known *No-Skive* hoses – *Elite* braided in the medium pressure range and Parkrimp spiral.

Better High Pressure

**Parkrimp
701, 731**

Fitting Series



Best

Category “Best” contains GLOBALCORE™ hose products which are meeting or even exceeding the latest and most demanding International Standard ISO 18752. GLOBALCORE™ is the world’s first high performance, cohesive hose and fitting range. GLOBALCORE™ hoses have constant working pressures of 21.0 or 28.0 MPa in the medium pressure range and 35.0 or 42.0 MPa in the high pressure range.

Best High Pressure

**GLOBALCORE™
787, 797**

Fitting Series



Good

Newly developed high performance *No-Skive* hoses

SX spiral hoses – meeting international technical standards – newly developed for demanding small and medium OEMs and general distribution.

SX35 Multispiral

ISO 3862 Type R13



Size -12, -16, -20
-40 °C up to +125 °C
Constant working pressure 35.0 MPa



Parker NO-SKIVE - SX35-12 WP 35,0 MPa (5000 PSI) 1" ISO 3862 4SP / R13

SX42 Multispiral

ISO 3862 Type R15



Size -12, -16, -20
-40 °C up to +125 °C
Constant working pressure 42.0 MPa



Parker NO-SKIVE - SX42-12 WP 42,0 MPa (6000 PSI) 1" ISO 3862 R15 - 19 m

Customers choice is the key

Good, Better, Best classification for easier hose and fitting selection

- Different levels for different markets and applications
- Help customers to make better buying decision
- Defined hose and fitting combination on hose layline
- Clear visibility of correct fitting
- Easy to understand
- Ensures quality of hose and fitting combination

Superior performance of Best hoses versus Better and Good hoses

- Bend radius up to 50% smaller
- Flexibility (bending force) up to 30% higher
- Weight up to 20% lower
- Dimensions up to 25% smaller area
- Impulse resistance and service life up to four times higher
- Working temperature up to 25% higher

Construction is one of the typical markets and applications where „Good hose and fittings“ are the preferred product selection.



GLOBALCORE™

The world's first high-performance, cohesive hose and fitting system

722 / 722TC / 722ST *No-Skive* GlobalCore

Resilient 4-wire spiral construction

Primary Applications

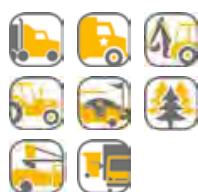

Parker's GlobalCore 722 spiral hose provides 28 MPa (4,000 psi) constant working pressure in sizes -6 through -16. Designed for high-pressure, high-impulse applications, 722 hose is offered in Standard, ToughCover and SuperTough cover options.

It is one-half the bend radius of 100R12 hose, making it easy to install and reducing the amount of hose needed. Exceeding the ISO 18752 performance specification, Parker's 722 hose excels in multiple applications around the world.

787 / 787TC / 787ST *No-Skive* GlobalCore

Lighter weight, high flexibility make installation easy

Primary Applications



Parker's GlobalCore 787 hose provides 35 MPa (5,000 psi) constant working pressure in all sizes. Compared with conventional spiral hose, 787 hose offers measurably greater advantages in routing and installation, product size and weight, inventory savings and much more. The 787 hose exceeds the ISO 18752 performance specification.

797 / 797TC / 797ST *No-Skive* GlobalCore

Lighter weight, high flexibility make installation easy

Primary Applications



Parker's GlobalCore 797 hose provides 42 MPa (6,000 psi) constant working pressure in all sizes. Compared with conventional spiral hose, 797 hose offers measurably greater advantages in routing and installation, product size and weight, inventory savings and much more. The 797 hose exceeds the ISO 18752 performance specification.



D-6

www.parker.com/globalcore

GlobalCore significantly reduces system complexity



- ½ ISO 18752 minimum bend radius
- 28 MPa (4,000 psi) constant working pressure
- Exceeds ISO 18752 performance specification (BC and CC)
- 4-spiral construction for longer life in high-impulse, heavy-duty cycle applications
- TC cover provides 80 times the abrasion resistance compared to Standard rubber cover hoses
- ST cover provides 450 times the abrasion resistance compared to Standard rubber cover hoses



- ½ ISO 18752 minimum bend radius
- 35 MPa (5,000 psi) constant working pressure in all sizes
- Exceeds ISO 18752 performance specification (BC/DC)
- Nearly 30 % smaller O.D. by area than SAE spiral
- Twice the impulse/life – tested to 2,000,000 cycles
- Flex impulse tested, providing a hose superior in both performance and service life
- 30 % less hose weight than SAE spiral
- TC cover provides 80 times the abrasion resistance compared to Standard rubber cover hoses
- ST cover provides 450 times the abrasion resistance compared to Standard rubber cover hoses



- ½ the bend radius of SAE spiral
- 42 MPa (6,000 psi) constant working pressure in all sizes
- Exceeds ISO 18752 performance specification (BC/CC/DC)
- Nearly 30 % smaller O.D. by area than SAE spiral
- Twice the impulse/life – tested to 2,000,000 cycles
- Flex impulse tested, providing a hose superior in both performance and service life
- 30 % less hose weight than SAE spiral
- TC cover provides 80 times the abrasion resistance compared to Standard rubber cover hoses
- ST cover provides 450 times the abrasion resistance compared to Standard rubber cover hoses

Full Flange System

Provides full flange mounting option for ISO 6162-1 (35.0 MPa/5000 psi) and ISO 6162-2 (42.0 MPa/ 6000 psi) flanges – system flexibility reduces inventory investment.

The full flange system addresses the needs of customers by:

- Being easier to assemble
- Providing one-piece integrity
- Being easier to handle
- Being easier to route in tight spaces
- Enabling assemblies to be sent to customers with the flange in place
- Easing bent tube installation (displacement angle) with a freely rotating flange



The full flange system can be used repeatedly because of its patent-pending attachment system – the flange is not permanently locked onto the fitting.

- This is not a captive flange – it can easily be removed
- Flange can be reused if necessary
- Flange is not scrapped on a mis-crimp

Fitting Configuration

This fitting configuration is specifically designed for Parker's full flange system, and will accept either a ISO 6162-1 or ISO 6162-2 flange. The X5, X7 and X9 fittings are designed to work with all Parkrimp crimpers. These fittings can replace multiple existing fittings and help to reduce inventory.

Reduction of Inventory

Parker's full flange system requires less inventory than the existing split flange system.

By using the new X5, X7 and X9 fittings, distributors can streamline inventory and can still respond to customer needs. Before the introduction of the full flange system, distributors needed to stock both ISO 6162 fittings to be prepared.

For more information about Full Flange System please refer to pages Dd-18, Dd-19, Df-19, Df-20, Eb-4 and Eb-5



1X577-20-20

Straight
ISO 6162-1 or ISO 6162-2 fitting
Alternative to 15, 4A and 6A

1X777-20-20

45°
ISO 6162-1 or ISO 6162-2 fitting
Alternative to 17, 4F and 6F

1X977-20-20

90°
ISO 6162-1 or ISO 6162-2 fitting
Alternative to 19, 4N and 6N

High Pressure GLOBALCORE™

| Hoses | | | Page |
|-------|------------------------------|----------------------------------------------|-------|
| Best | 722 <i>No-Skive</i> | Standard | Daa-1 |
| Best | 722TC <i>No-Skive</i> | High abrasion resistance | Daa-2 |
| Best | 722ST <i>No-Skive</i> | Extreme abrasion resistance | Daa-3 |
| Best | 787 <i>No-Skive</i> | Compact Spiral | Daa-4 |
| Best | 787TC <i>No-Skive</i> | Compact Spiral – High abrasion resistance | Daa-5 |
| Best | 787ST <i>No-Skive</i> | Compact Spiral – Extreme abrasion resistance | Daa-6 |
| Best | 797 <i>No-Skive</i> | Compact Spiral | Daa-7 |
| Best | 797TC <i>No-Skive</i> | Compact Spiral – High abrasion resistance | Daa-8 |
| Best | 797ST <i>No-Skive</i> | Compact Spiral – Extreme abrasion resistance | Daa-9 |

| | |
|------------------|-------|
| Fittings Series | 77 |
| Chapter | Dd |
| DIN – Metric | 1–4 |
| BSP | 5–6 |
| SAE | 7–9 |
| Flange | 10–20 |
| ORFS | 21–23 |
| French Standard | 24 |
| Special Fittings | 25 |

Parker Hannifin assumes no liability for typographical errors or other errors



Parkrimp

Standard



High abrasion resistance



Extreme abrasion resistance

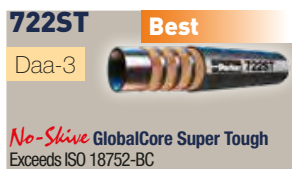

Compact Spiral



Compact Spiral – High abrasion resistance

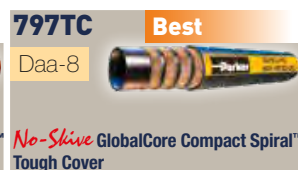
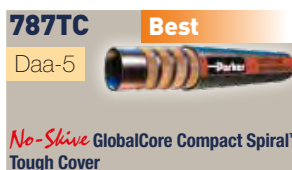

Compact Spiral – Extreme abrasion resistance

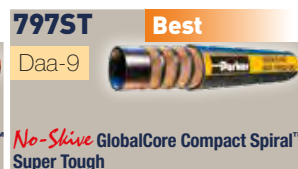
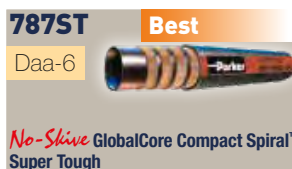

722

No-Skive GlobalCore

Exceeds ISO 18752-BC



- *No-Skive* hose construction
- ½ ISO 18752 minimum bend radius
- 28 MPa constant working pressure
- Exceeds ISO 18752 BC performance specification
- 4-spiral construction for longer life in high-impulse, heavy-duty cycle applications

Primary Applications

General high pressure hydraulic applications

Applicable Specifications

Exceed ISO 18752-BC

Construction

Inner tube: Synthetic rubber
Reinforcement: Four spiral high-tensile steel wire
Cover: Synthetic rubber

Temperature Range -40 °C up to +100 °C

Exception: Air max. +70 °C

Water max. +85 °C

Recommended Fluids

Hydraulic fluids on a mineral-oil basis, water-glycol and lubricating oils, air and water. For air and gas applications with a pressure exceeding 1.7 MPa, the cover must be pin-pricked. Consult the chemical compatibility section on pages **Ab-26** to **Ab-34** for more detailed information.

Fitting Series



Series 43 you'll find in the Medium Pressure chapter Cb

| Part Number | Hose I.D. | | | | Hose O.D. mm | Pressure Rating | | | | min. bend radius mm | weight kg |
|-------------|-----------|------|------|------|-----------------|------------------------------|------|----------------------------|-------|------------------------|--------------|
| | DN | Inch | Size | mm | | max. working pressure MPa | psi | min. burst pressure MPa | psi | | |
| 722-6 | 10 | 3/8 | -6 | 9.5 | 19.9 | 28.0 | 4000 | 112.0 | 16000 | 65 | 0.60 |
| 722-8 | 12 | 1/2 | -8 | 12.7 | 22.7 | 28.0 | 4000 | 112.0 | 16000 | 90 | 0.80 |
| 722-10 | 16 | 5/8 | -10 | 15.9 | 26.4 | 28.0 | 4000 | 112.0 | 16000 | 100 | 1.10 |
| 722-12 | 19 | 3/4 | -12 | 19.1 | 30.7 | 28.0 | 4000 | 112.0 | 16000 | 120 | 1.40 |
| 722-16 | 25 | 1 | -16 | 25.4 | 37.8 | 28.0 | 4000 | 112.0 | 16000 | 150 | 1.99 |

The combination of high temperature and high pressure could reduce the hose life.

GLOBALCORE

Hose layline example



Daa-1

Catalogue 4400/UK

High Pressure GLOBALCORE
High abrasion resistance

Parkrimp No-Skive Hose
722TC

722TC

No-Skive GlobalCore Tough Cover
Exceeds ISO 18752-BC

Primary Applications

General high pressure hydraulic applications

Type Approvals

Details please find on pages **Ab-16** to **Ab-19**

Applicable Specifications

SAE 100R12 – EN 856 Type R12 –
ISO 3862 Type R12

Construction

Inner tube: Nitrile (NBR)
Reinforcement: Four spiral high-tensile steel wire
Cover: Highly abrasion resistance
MSHA approved synthetic rubber

Temperature Range -40 °C up to +125 °C

Exception: Air max. +70 °C
Water max. +85 °C



- **No-Skive** hose construction – Compact design
- 1/2 the bend radius of SAE 100R12
- Constant working pressure of 28.0 MPa
- Exceeds ISO 18752 BC performance specification
- Highly abrasion resistant **TOUGH COVER**
- MSHA approved
- Hose is suitable for temporary immersion in mineral oil up to 70 °C with frequent inspections

Recommended Fluids

Hydraulic fluids on a mineral-oil basis, water-glycol and lubricating oils, air and water. For air and gas applications with a pressure exceeding 1.7 MPa, the cover must be pin-pricked. Consult the chemical compatibility section on pages **Ab-26** to **Ab-34** for more detailed information.

Fitting Series



Series 43 you'll find in the Medium Pressure chapter Cb

| Part Number | Hose I.D. | | | | Hose O.D. mm | Pressure Rating | | | | min. bend radius mm | weight kg |
|-------------|-----------|------|------|------|-----------------|------------------------------|------|----------------------------|-------|------------------------|--------------|
| | DN | Inch | Size | mm | | max. working pressure MPa | psi | min. burst pressure MPa | psi | | |
| 722TC-6 | 10 | 3/8 | -6 | 9.5 | 19.9 | 28.0 | 4000 | 112.0 | 16000 | 65 | 0.60 |
| 722TC-8 | 12 | 1/2 | -8 | 12.7 | 22.7 | 28.0 | 4000 | 112.0 | 16000 | 90 | 0.80 |
| 722TC-10 | 16 | 5/8 | -10 | 15.9 | 26.4 | 28.0 | 4000 | 112.0 | 16000 | 100 | 1.10 |
| 722TC-12 | 19 | 3/4 | -12 | 19.1 | 30.7 | 28.0 | 4000 | 112.0 | 16000 | 120 | 1.40 |
| 722TC-16 | 25 | 1 | -16 | 25.4 | 37.8 | 28.0 | 4000 | 112.0 | 16000 | 150 | 1.99 |

Replace the hose when any deformation or damage on the hose cover are visible.
The combination of high temperature and high pressure could reduce the hose life.

Hose layline example

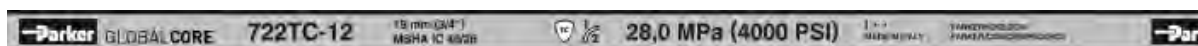

Daa-2

Catalogue 4400/UK

722ST

No-Skive GlobalCore Super Tough
Exceeds ISO 18752-BC



- *No-Skive* hose construction
- ½ ISO 18752 minimum bend radius
- 28 MPa constant working pressure
- Exceeds ISO 18752 BC performance specification
- Extreme abrasion resistant **SUPER TOUGH** cover
- 4-spiral construction for longer life in high-impulse, heavy-duty cycle applications

Primary Applications

General high pressure hydraulic applications

Applicable Specifications

Exceeds ISO 18752-BC

Construction

Inner tube: Synthetic rubber
Reinforcement: Four spiral high-tensile steel wire
Cover: Synthetic rubber with a special polyethylene coating

Temperature Range -40 °C up to +125 °C

Exception: Air max. +70 °C
Water max. +85 °C

Recommended Fluids

Hydraulic fluids on a mineral-oil basis, water-glycol and lubricating oils, air and water. For air and gas applications with a pressure exceeding 1.7 MPa, the cover must be pin-pricked. Consult the chemical compatibility section on pages **Ab-26** to **Ab-34** for more detailed information.

Fitting Series



Series 43 you'll find in the Medium Pressure chapter Cb

| Part Number | Hose I.D. | | | | Hose O.D. mm | Pressure Rating | | | | min. bend radius mm | weight kg |
|-------------|-----------|------|------|------|-----------------|------------------------------|------|----------------------------|-------|------------------------|--------------|
| | DN | Inch | Size | mm | | max. working pressure MPa | psi | min. burst pressure MPa | psi | | |
| 722ST-6 | 10 | 3/8 | -6 | 9.5 | 19.9 | 28.0 | 4000 | 112.0 | 16000 | 65 | 0.60 |
| 722ST-8 | 12 | 1/2 | -8 | 12.7 | 22.7 | 28.0 | 4000 | 112.0 | 16000 | 90 | 0.80 |
| 722ST-10 | 16 | 5/8 | -10 | 15.9 | 26.4 | 28.0 | 4000 | 112.0 | 16000 | 100 | 1.10 |
| 722ST-12 | 19 | 3/4 | -12 | 19.1 | 30.7 | 28.0 | 4000 | 112.0 | 16000 | 120 | 1.40 |
| 722ST-16 | 25 | 1 | -16 | 25.4 | 37.8 | 28.0 | 4000 | 112.0 | 16000 | 150 | 1.99 |

The combination of high temperature and high pressure could reduce the hose life.

Hose layline example

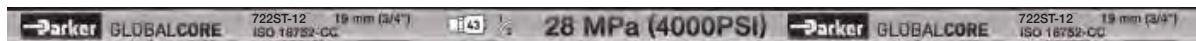

787

No-Skive GlobalCore Compact Spiral™

Sizes -4 to -6 exceed ISO 18752-AC
Sizes -8 to -32 exceed ISO 18752-BC



- 1/2 the bend radius of SAE 100R13
- Constant working pressure of 35.0 MPa
- Reduced O.D. and new construction lead to superior flexibility
- 1/3 less effort to bend
- Weight reduction – up to 26 %

Primary Applications

On- & offshore, construction, injection moulding, mining

Applicable Specifications

Exceeds ISO 18752-AC/BC

Construction

Inner tube: Proprietary synthetic rubber
Reinforcement: Two braid steel wire for sizes -4 to -6,
four or six compact spiral steel wire
for sizes - 8 to -32
Cover: Synthetic rubber

Recommended Fluids

Petroleum based hydraulic fluids and lubricating oils.
Wide Compatibility exceeding Column III, with additional
chemical resistance, especially for diesel and biodiesel.
Consult the chemical compatibility section on
pages **Ab-26** to **Ab-34** for more detailed information.

Temperature Range -40 °C up to +100 °C

Exception: Air max. +70 °C
Water max. +85 °C

Fitting Series

Series 43/48 for sizes -4 and -6



Series 77 for sizes -8 up to -32

| Part Number | Hose I.D. | | | | Hose O.D. mm | Pressure Rating | | | | min. bend radius mm | weight kg |
|-------------|-----------|-------|------|------|-----------------|------------------------------|------|----------------------------|-------|------------------------|--------------|
| | DN | Inch | Size | mm | | max. working pressure MPa | psi | min. burst pressure MPa | psi | | |
| 787-4 | 6 | 1/4 | -4 | 6.3 | 13.0 | 35.0 | 5000 | 140.0 | 20000 | 50 | 0.31 |
| 787-6 | 10 | 3/8 | -6 | 10.0 | 17.2 | 35.0 | 5000 | 140.0 | 20000 | 63 | 0.42 |
| 787-8 | 12 | 1/2 | -8 | 12.7 | 21.1 | 35.0 | 5000 | 140.0 | 20000 | 90 | 0.67 |
| 787-10 | 16 | 5/8 | -10 | 15.9 | 23.9 | 35.0 | 5000 | 140.0 | 20000 | 100 | 0.80 |
| 787-12 | 19 | 3/4 | -12 | 19.1 | 27.9 | 35.0 | 5000 | 140.0 | 20000 | 120 | 1.16 |
| 787-16 | 25 | 1 | -16 | 25.4 | 35.7 | 35.0 | 5000 | 140.0 | 20000 | 150 | 1.74 |
| 787-20 | 31 | 1 1/4 | -20 | 31.8 | 44.9 | 35.0 | 5000 | 140.0 | 20000 | 210 | 2.89 |
| 787-24 | 38 | 1 1/2 | -24 | 38.1 | 52.8 | 35.0 | 5000 | 140.0 | 20000 | 255 | 3.96 |
| 787-32 | 51 | 2 | -32 | 50.8 | 67.6 | 35.0 | 5000 | 140.0 | 20000 | 318 | 6.50 |

Replace the hose when any deformation or damage on the hose cover are visible.
The combination of high temperature and high pressure could reduce the hose life.

Hose layline example



787TC

No-Skive GlobalCore Compact Spiral™

Tough Cover

Sizes -4 to -6 exceed ISO 18752-AC
Sizes -8 to -32 exceed ISO 18752-DC

Primary Applications

On- & offshore, construction, injection moulding, mining

Type Approvals

Details please find on pages **Ab-16** to **Ab-19**

Applicable Specifications

Exceeds SAE 100R13 – ISO 3862 Type R13 –
EN 856 Type R13 – ISO 18752-AC/DC

Construction

Inner tube: Proprietary synthetic rubber
Reinforcement: Two braid steel wire for sizes -4 to -6,
four or six compact spiral steel wire
for sizes -8 to -32
Cover: Highly abrasion resistance
MSHA approved synthetic rubber

Temperature Range -40 °C up to +125 °C
(sizes -4 to -6 up to +100 °C)

Exception: Air max. +70 °C
Water max. +85 °C



- 1/2 the bend radius of SAE 100R13
- Constant working pressure of 35.0 MPa
- Reduced O.D. and new construction lead to superior flexibility
- 1/3 less effort to bend
- Weight reduction – up to 26 %
- Highly abrasion resistant **TOUGH COVER**
- MSHA approved
- Hose is suitable for temporary immersion in mineral oil up to 70 °C with frequent inspections

Recommended Fluids

Petroleum based hydraulic fluids and lubricating oils.
Wide Compatibility exceeding Column III, with additional chemical resistance, especially for diesel and biodiesel.
Consult the chemical compatibility section on pages **Ab-26** to **Ab-34** for more detailed information.

Fitting Series

Series 43/48 for sizes -4 and -6



Series 77 for sizes -8 up to -32



| Part Number | Hose I.D. | | | | Hose O.D. mm | Pressure Rating | | | | min. bend radius mm | weight kg |
|-------------|-----------|-------|------|------|-----------------|------------------------------|------|----------------------------|-------|------------------------|--------------|
| | DN | Inch | Size | mm | | max. working pressure MPa | psi | min. burst pressure MPa | psi | | |
| 787TC-4 | 6 | 1/4 | -4 | 6.3 | 13.0 | 35.0 | 5000 | 140.0 | 20000 | 50 | 0.31 |
| 787TC-6 | 10 | 3/8 | -6 | 10.0 | 17.2 | 35.0 | 5000 | 140.0 | 20000 | 63 | 0.42 |
| 787TC-8 | 12 | 1/2 | -8 | 12.7 | 21.1 | 35.0 | 5000 | 140.0 | 20000 | 90 | 0.67 |
| 787TC-10 | 16 | 5/8 | -10 | 15.9 | 23.9 | 35.0 | 5000 | 140.0 | 20000 | 100 | 0.80 |
| 787TC-12 | 19 | 3/4 | -12 | 19.1 | 27.9 | 35.0 | 5000 | 140.0 | 20000 | 120 | 1.16 |
| 787TC-16 | 25 | 1 | -16 | 25.4 | 35.7 | 35.0 | 5000 | 140.0 | 20000 | 150 | 1.74 |
| 787TC-20 | 31 | 1 1/4 | -20 | 31.8 | 44.9 | 35.0 | 5000 | 140.0 | 20000 | 210 | 2.89 |
| 787TC-24 | 38 | 1 1/2 | -24 | 38.1 | 52.8 | 35.0 | 5000 | 140.0 | 20000 | 255 | 3.96 |
| 787TC-32 | 51 | 2 | -32 | 50.8 | 67.6 | 35.0 | 5000 | 140.0 | 20000 | 318 | 6.50 |

Replace the hose when any deformation or damage on the hose cover are visible.
The combination of high temperature and high pressure could reduce the hose life.

Hose layline example



787ST

No-Skive GlobalCore Compact Spiral™

Super Tough

Sizes -4 to -6 exceed ISO 18752-AC
Sizes -8 to -32 exceed ISO 18752-DC

Primary Applications

On- & offshore, construction, injection moulding, mining

Type Approvals

Details please find on pages **Ab-16** to **Ab-19**

Applicable Specifications

Exceeds SAE 100R13 – ISO 3862 Type R13 –
EN 856 Type R13 – ISO 18752-AC/DC

Construction

Inner tube: Proprietary synthetic rubber
Reinforcement: Two braid steel wire for sizes -4 to -6,
four or six compact spiral steel wire
for sizes -8 to -32
Cover: Synthetic rubber
with a special polyethylene coating

Temperature Range -40 °C up to +125 °C
(sizes -4 to -6 up to +100 °C)

Exception: Air max. +70 °C
Water max. +85 °C



- 1/2 the bend radius of SAE 100R13
- Constant working pressure of 35.0 MPa
- Reduced O.D. and new construction lead to superior flexibility
- 1/3 less effort to bend
- Weight reduction – up to 26 %
- Extreme abrasion resistant
SUPER TOUGH cover

Recommended Fluids

Petroleum based hydraulic fluids and lubricating oils.
Wide Compatibility exceeding Column III, with additional
chemical resistance, especially for diesel and biodiesel.
Consult the chemical compatibility section on
pages **Ab-26** to **Ab-34** for more detailed information.

Fitting Series

Series 43/48 for sizes -4 and -6



Series 77 for sizes -8 up to -32

| Part Number | Hose I.D. | | | | Hose O.D. mm | Pressure Rating | | | | min. bend radius mm | weight kg |
|-------------|-----------|-------|------|------|-----------------|------------------------------|------|----------------------------|-------|------------------------|--------------|
| | DN | Inch | Size | mm | | max. working pressure MPa | psi | min. burst pressure MPa | psi | | |
| 787ST-4 | 6 | 1/4 | -4 | 6.3 | 13.0 | 35.0 | 5000 | 140.0 | 20000 | 50 | 0.31 |
| 787ST-6 | 10 | 3/8 | -6 | 10.0 | 17.2 | 35.0 | 5000 | 140.0 | 20000 | 63 | 0.42 |
| 787ST-8 | 12 | 1/2 | -8 | 12.7 | 21.1 | 35.0 | 5000 | 140.0 | 20000 | 90 | 0.67 |
| 787ST-10 | 16 | 5/8 | -10 | 15.9 | 23.9 | 35.0 | 5000 | 140.0 | 20000 | 100 | 0.80 |
| 787ST-12 | 19 | 3/4 | -12 | 19.1 | 27.9 | 35.0 | 5000 | 140.0 | 20000 | 120 | 1.16 |
| 787ST-16 | 25 | 1 | -16 | 25.4 | 35.7 | 35.0 | 5000 | 140.0 | 20000 | 150 | 1.74 |
| 787ST-20 | 31 | 1 1/4 | -20 | 31.8 | 44.9 | 35.0 | 5000 | 140.0 | 20000 | 210 | 2.89 |
| 787ST-24 | 38 | 1 1/2 | -24 | 38.1 | 52.8 | 35.0 | 5000 | 140.0 | 20000 | 255 | 3.96 |
| 787ST-32 | 51 | 2 | -32 | 50.8 | 67.6 | 35.0 | 5000 | 140.0 | 20000 | 318 | 6.50 |

Replace the hose when any deformation or damage on the hose cover are visible.
The combination of high temperature and high pressure could reduce the hose life.

Hose layline example

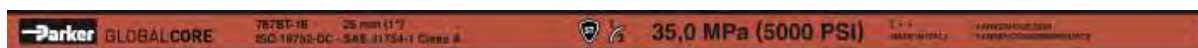

797

No-Skive GlobalCore Compact Spiral™

Size -4 exceeds ISO 18752-AC
Sizes -6 to -32 exceed ISO 18752-BC

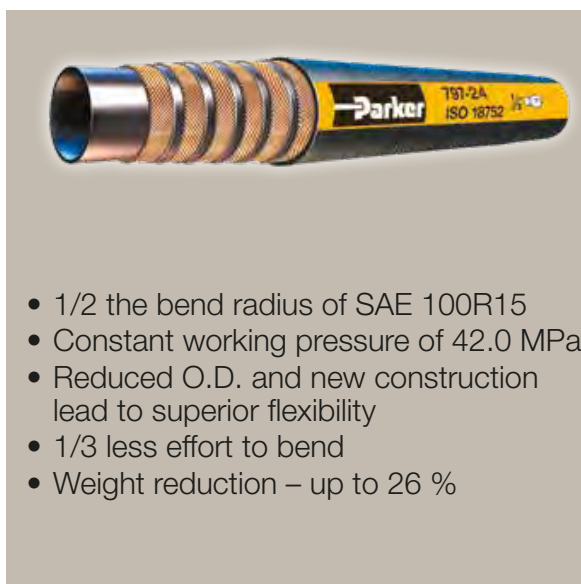

- 1/2 the bend radius of SAE 100R15
- Constant working pressure of 42.0 MPa
- Reduced O.D. and new construction lead to superior flexibility
- 1/3 less effort to bend
- Weight reduction – up to 26 %

Primary Applications

On- & offshore, construction, injection moulding, mining

Applicable Specifications

Exceed ISO 18752-AC/CC/DC

Construction

Inner tube: Proprietary synthetic rubber
Reinforcement: Two braid steel wire for size -4,
four or six compact spiral steel wire
for sizes -6 to -32
Cover: Synthetic rubber

Temperature Range -40 °C up to +100 °C

Exception: Air max. +70 °C

Water max. +85 °C

Recommended Fluids

Petroleum based hydraulic fluids and lubricating oils.
Wide Compatibility exceeding Column III, with additional
chemical resistance, especially for diesel and biodiesel.
Consult the chemical compatibility section on
pages **Ab-26** to **Ab-34** for more detailed information.

Fitting Series

Series 43/48 for size -4



Series 43 for size -6



Series 77 for sizes -8 up to -32



| Part Number | Hose I.D. | | | | Hose O.D. mm | Pressure Rating | | | | min. bend radius mm | weight kg |
|-------------|-----------|-------|------|------|-----------------|------------------------------|------|----------------------------|-------|------------------------|--------------|
| | DN | Inch | Size | mm | | max. working pressure MPa | psi | min. burst pressure MPa | psi | | |
| 797-4 | 6 | 1/4 | -4 | 6.3 | 13.0 | 42.0 | 6000 | 168.0 | 24000 | 50 | 0.31 |
| 797-6 | 10 | 3/8 | -6 | 10.0 | 17.0 | 42.0 | 6000 | 168.0 | 24000 | 63 | 0.46 |
| 797-8 | 12 | 1/2 | -8 | 12.7 | 21.1 | 42.0 | 6000 | 168.0 | 24000 | 100 | 0.67 |
| 797-10 | 16 | 5/8 | -10 | 15.9 | 23.9 | 42.0 | 6000 | 168.0 | 24000 | 115 | 0.80 |
| 797-12 | 19 | 3/4 | -12 | 19.1 | 27.9 | 42.0 | 6000 | 168.0 | 24000 | 135 | 1.16 |
| 797-16 | 25 | 1 | -16 | 25.4 | 35.7 | 42.0 | 6000 | 168.0 | 24000 | 165 | 1.74 |
| 797-20 | 31 | 1 1/4 | -20 | 31.8 | 44.9 | 42.0 | 6000 | 168.0 | 24000 | 225 | 2.89 |
| 797-24 | 38 | 1 1/2 | -24 | 38.1 | 52.8 | 42.0 | 6000 | 168.0 | 24000 | 305 | 3.96 |
| 797-32 | 51 | 2 | -32 | 50.8 | 67.6 | 42.0 | 6000 | 168.0 | 24000 | 380 | 6.50 |

Replace the hose when any deformation or damage on the hose cover are visible.
The combination of high temperature and high pressure could reduce the hose life.

Hose layline example



High Pressure GLOBALCORE
Compact Spiral – High abrasion resistance

Parkrimp No-Skive Hose
797TC

797TC

No-Skive GlobalCore Compact Spiral™

Tough Cover

Size -4 exceeds ISO 18752-AC
Sizes -8 to -20 exceed ISO 18752-DC
Sizes -6, -24, -32 exceed ISO 18752-CC

Primary Applications

On- & offshore, construction, injection moulding, mining

Type Approvals

Details please find on pages **Ab-16** to **Ab-19**

Applicable Specifications

Exceeds SAE 100R15 – ISO 3862 Type R15 –
ISO 18752-AC/CC/DC

Construction

Inner tube: Proprietary synthetic rubber
Reinforcement: Two braid steel wire for size -4,
four or six compact spiral steel wire
for sizes -6 to -32
Cover: Highly abrasion resistance
MSHA approved synthetic rubber

Temperature Range -40 °C up to +125 °C
(size -4 up to +100 °C)

Exception: Air max. +70 °C
Water max. +85 °C

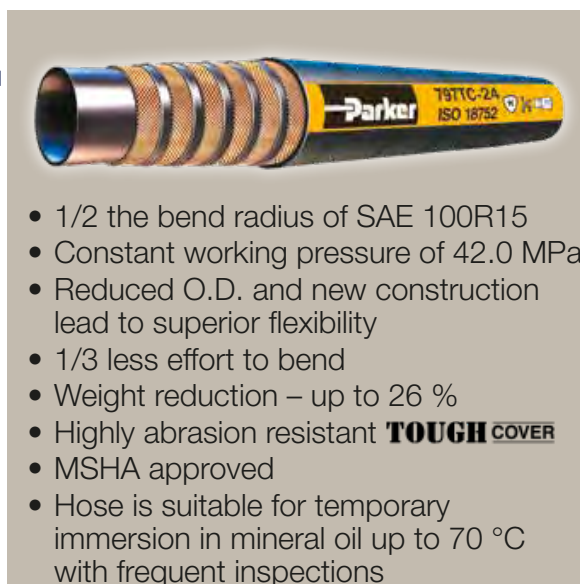

- 1/2 the bend radius of SAE 100R15
- Constant working pressure of 42.0 MPa
- Reduced O.D. and new construction lead to superior flexibility
- 1/3 less effort to bend
- Weight reduction – up to 26 %
- Highly abrasion resistant **TOUGH COVER**
- MSHA approved
- Hose is suitable for temporary immersion in mineral oil up to 70 °C with frequent inspections

Recommended Fluids

Petroleum based hydraulic fluids and lubricating oils.
Wide Compatibility exceeding Column III, with additional chemical resistance, especially for diesel and biodiesel.
Consult the chemical compatibility section on pages **Ab-26** to **Ab-34** for more detailed information.

Fitting Series

Series 43/48 for size-4



Series 43 for size -6



Series 77 for sizes -8 up to -32



| Part Number | Hose I.D. | | | | Hose O.D. mm | Pressure Rating | | | | min. bend radius mm | weight kg |
|-------------|-----------|-------|------|------|-----------------|------------------------------|------|----------------------------|-------|------------------------|--------------|
| | DN | Inch | Size | mm | | max. working pressure MPa | psi | min. burst pressure MPa | psi | | |
| 797TC-4 | 6 | 1/4 | -4 | 6.3 | 13.0 | 42.0 | 6000 | 168.0 | 24000 | 50 | 0.31 |
| 797TC-6 | 10 | 3/8 | -6 | 10.0 | 17.0 | 42.0 | 6000 | 168.0 | 24000 | 63 | 0.46 |
| 797TC-8 | 12 | 1/2 | -8 | 12.7 | 21.1 | 42.0 | 6000 | 168.0 | 24000 | 100 | 0.67 |
| 797TC-10 | 16 | 5/8 | -10 | 15.9 | 23.9 | 42.0 | 6000 | 168.0 | 24000 | 115 | 0.80 |
| 797TC-12 | 19 | 3/4 | -12 | 19.1 | 27.9 | 42.0 | 6000 | 168.0 | 24000 | 135 | 1.16 |
| 797TC-16 | 25 | 1 | -16 | 25.4 | 35.7 | 42.0 | 6000 | 168.0 | 24000 | 165 | 1.74 |
| 797TC-20 | 31 | 1 1/4 | -20 | 31.8 | 44.9 | 42.0 | 6000 | 168.0 | 24000 | 225 | 2.89 |
| 797TC-24 | 38 | 1 1/2 | -24 | 38.1 | 52.8 | 42.0 | 6000 | 168.0 | 24000 | 305 | 3.96 |
| 797TC-32 | 51 | 2 | -32 | 50.8 | 67.6 | 42.0 | 6000 | 168.0 | 24000 | 380 | 6.50 |

Replace the hose when any deformation or damage on the hose cover are visible.
The combination of high temperature and high pressure could reduce the hose life.

Hose layline example



Daa-8

Catalogue 4400/UK

797ST

No-Skive GlobalCore Compact Spiral™

Super Tough

Size -4 exceeds ISO 18752-AC
Sizes -8 to -20 exceed ISO 18752-DC
Sizes -6, -24, -32 exceed ISO 18752-CC

Primary Applications

On- & offshore, construction, injection moulding, mining

Type Approvals

Details please find on pages **Ab-16** to **Ab-19**

Applicable Specifications

Exceeds SAE 100R15 – ISO 3862 Type R15 –
ISO 18752-AC/CC/DC

Construction

Inner tube: Proprietary synthetic rubber
Reinforcement: Two braid steel wire for size -4,
four or six compact spiral steel wire
for sizes -6 to -32
Cover: Synthetic rubber
with a special polyethylene coating

Temperature Range -40 °C up to +125 °C
(size -4 up to +100 °C)

Exception: Air max. +70 °C
Water max. +85 °C



- 1/2 the bend radius of SAE 100R15
- Constant working pressure of 42.0 MPa
- Reduced O.D. and new construction lead to superior flexibility
- 1/3 less effort to bend
- Weight reduction – up to 26 %
- Extreme abrasion resistant

SUPER TOUGH cover

Recommended Fluids

Petroleum based hydraulic fluids and lubricating oils.
Wide Compatibility exceeding Column III, with additional
chemical resistance, especially for diesel and biodiesel.
Consult the chemical compatibility section on
pages **Ab-26** to **Ab-34** for more detailed information.

Fitting Series

Series 43/48 for size -4



Series 43 for size -6



Series 77 for sizes -8 up to -32



| Part Number | Hose I.D. | | | | Hose O.D. mm | Pressure Rating | | | | min. bend radius mm | weight kg |
|-------------|-----------|-------|------|------|-----------------|------------------------------|------|----------------------------|-------|------------------------|--------------|
| | DN | Inch | Size | mm | | max. working pressure MPa | psi | min. burst pressure MPa | psi | | |
| 797ST-4 | 6 | 1/4 | -4 | 6.3 | 13.0 | 42.0 | 6000 | 168.0 | 24000 | 50 | 0.31 |
| 797ST-6 | 10 | 3/8 | -6 | 10.0 | 17.0 | 42.0 | 6000 | 168.0 | 24000 | 63 | 0.46 |
| 797ST-8 | 12 | 1/2 | -8 | 12.7 | 21.1 | 42.0 | 6000 | 168.0 | 24000 | 100 | 0.67 |
| 797ST-10 | 16 | 5/8 | -10 | 15.9 | 23.9 | 42.0 | 6000 | 168.0 | 24000 | 115 | 0.80 |
| 797ST-12 | 19 | 3/4 | -12 | 19.1 | 27.9 | 42.0 | 6000 | 168.0 | 24000 | 135 | 1.16 |
| 797ST-16 | 25 | 1 | -16 | 25.4 | 35.7 | 42.0 | 6000 | 168.0 | 24000 | 165 | 1.74 |
| 797ST-20 | 31 | 1 1/4 | -20 | 31.8 | 44.9 | 42.0 | 6000 | 168.0 | 24000 | 225 | 2.89 |
| 797ST-24 | 38 | 1 1/2 | -24 | 38.1 | 52.8 | 42.0 | 6000 | 168.0 | 24000 | 305 | 3.96 |
| 797ST-32 | 51 | 2 | -32 | 50.8 | 67.6 | 42.0 | 6000 | 168.0 | 24000 | 380 | 6.50 |

Replace the hose when any deformation or damage on the hose cover are visible.
The combination of high temperature and high pressure could reduce the hose life.

Hose layline example



High Pressure

| Hoses | | Page | |
|------------------------|-------------------------------------------|-----------------------------------|-----------------|
| Parkrimp | 371LT <i>No-Skive</i> | 3-braids low temperature | Dab-1 |
| | 372 <i>No-Skive</i> | 3-braids standard | Dab-2 |
| | 372RH <i>No-Skive</i> | 3-braids railway | Dab-3 |
| | 372TC <i>No-Skive</i> | 3-braids high abrasion resistance | Dab-4 |
| | Good SX35 <i>No-Skive</i> | Standard | Dab-5 |
| | SX35LT <i>No-Skive</i> | Low temperature | Dab-6 |
| | Good SX35TC <i>No-Skive</i> | High abrasion resistance | Dab-7 |
| | Good SX42 <i>No-Skive</i> | Standard | Dab-8 |
| | SX42LT <i>No-Skive</i> | Low temperature | Dab-9 |
| | Good SX42TC <i>No-Skive</i> | High abrasion resistance | Dab-10 |
| | Better 701 <i>No-Skive</i> | Standard | Dab-11 |
| | 701TC <i>No-Skive</i> | High abrasion resistance | Dab-12 |
| | Better 731 <i>No-Skive</i> | Standard | Dab-13 |
| | 731TC <i>No-Skive</i> | High abrasion resistance | Dab-14 |
| | 774 <i>No-Skive</i> | Phosphate Ester | Dab-15 |
| | 797RH | Railway | Dab-16 |
| | ParLock | F42 <i>No-Skive</i> | Phosphate Ester |
| H29 | | Standard | Dab-18 |
| H29TC | | High abrasion resistance | Dab-19 |
| H29ST | | Extreme abrasion resistance | Dab-20 |
| H31 | | Standard | Dab-21 |
| H31TC | | High abrasion resistance | Dab-22 |
| H31ST | | Extreme abrasion resistance | Dab-23 |
| R35 | | Standard | Dab-24 |
| R35TC/RS35TC-48 | | High abrasion resistance | Dab-25 |
| R42 | | Standard | Dab-26 |
| R42TC | | High abrasion resistance | Dab-27 |
| R42ST | | Extreme abrasion resistance | Dab-28 |
| R50TC/R56TC | | High abrasion resistance | Dab-29 |
| BPK | | Water-Blasting | Dab-30 |
| FA35 | | Firearmor Blowout Preventer | Dab-31 |
| RD35TC | | High abrasion resistance | Dab-32 |
| CEM69TC | | Cementing hose | Dab-33 |

| Fittings Series | Parkrimp | | | ParLock | | | |
|-------------------------|----------|-------|-------|---------|-------|-----|----|
| | 70 | 73 | 77 | VS | V4/V6 | V5 | WB |
| Chapter | Db | Dc | Dd | De | Df | Dg | Dh |
| Shell | | | | 1 | 1 | 1 | 1 |
| DIN – Metric | 1–4 | 1–4 | 1–4 | 2–5 | 2–5 | 2–3 | 2 |
| BSP | 5–7 | 5–6 | 5–6 | 6–7 | 6–8 | | 3 |
| SAE | 8–10 | 7–9 | 7–9 | 8–10 | 9–11 | | 4 |
| Flange | 11–14 | 10–15 | 10–20 | 11–13 | 12–22 | | |
| ORFS | 15–17 | 16–18 | 21–23 | 14–15 | 23–25 | | |
| French Standard | | | 24 | | | | |
| Others | 18 | 19 | | | | | |
| Special Fittings | | 20 | 25 | | | | |

Parker Hannifin assumes no liability for typographical errors or other errors



D-Index

Catalogue 4400/UK

Parkrimp

3-braids standard

372

Dab-2

No-Skive Compact

3-wire braid compact
hose with
4SP working pressures



3-braids low temperature

371LT

Dab-1

No-Skive Compact

3-wire braid low-temperature compact
hose with 4SP working pressures



3-braids high abrasion resistance

372TC

Dab-4

No-Skive Compact

3-wire braid compact hose
with
4SP working pressures



3-braids railway

372RH

Dab-3

No-Skive Compact

3-wire braid with fire-retardant cover



Parkrimp

Standard

| | | | |
|-------------------------------------------------------------------------------------------------------------------------------------------------------------------------------------------------------------------------------------------------------------------------------------|-------------------------------------------------------------------------------------------------------------------------------------------------------------------------------------------------------------------------------------------------------------------------------------|------------------------------------------------------------------------------------------------------------------------------------------------------------------------------------------------------------------------------------------------------------------------------------------|-------------------------------------------------------------------------------------------------------------------------------------------------------------------------------------------------------------------------------------------------------------------------------------------|
| <p>SX35 Good</p> <p>Dab-5 </p> <p><i>No-Skive Multispiral</i> ISO 3862 Type R13 – Parker Specifications</p> | <p>SX42 Good</p> <p>Dab-8 </p> <p><i>No-Skive Multispiral</i> ISO 3862 Type R15 – Parker Specifications</p> | <p>701 Better</p> <p>Dab-11 </p> <p><i>No-Skive Multispiral</i> Exceeds ISO 3862 Type 4SP – EN 856 Type 4SP</p> | <p>731 Better</p> <p>Dab-13 </p> <p><i>No-Skive Multispiral</i> Exceeds ISO 3862 Type 4SH – EN 856 Type 4SH</p> |
|-------------------------------------------------------------------------------------------------------------------------------------------------------------------------------------------------------------------------------------------------------------------------------------|-------------------------------------------------------------------------------------------------------------------------------------------------------------------------------------------------------------------------------------------------------------------------------------|------------------------------------------------------------------------------------------------------------------------------------------------------------------------------------------------------------------------------------------------------------------------------------------|-------------------------------------------------------------------------------------------------------------------------------------------------------------------------------------------------------------------------------------------------------------------------------------------|

Low temperature

| | |
|---------------------------------------------------------------------------------------------------------------------------------------------------------------------------------|---------------------------------------------------------------------------------------------------------------------------------------------------------------------------------|
| <p>SX35LT</p> <p>Dab-6 </p> <p><i>No-Skive Multispiral</i> Parker Specification</p> | <p>SX42LT</p> <p>Dab-9 </p> <p><i>No-Skive Multispiral</i> Parker Specification</p> |
|---------------------------------------------------------------------------------------------------------------------------------------------------------------------------------|---------------------------------------------------------------------------------------------------------------------------------------------------------------------------------|

Phosphate Ester

| | |
|-------------------------------------------------------------------------------------------------------------------------------------------------------------------------------------------|-------------------------------------------------------------------------------------------------------------------------------------------------------------------------------------------|
| <p>774</p> <p>Dab-15 </p> <p><i>No-Skive Multispiral</i> For phosphate ester base fluids</p> | <p>F42</p> <p>Dab-17 </p> <p><i>No-Skive Multispiral</i> For phosphate ester base fluids</p> |
|-------------------------------------------------------------------------------------------------------------------------------------------------------------------------------------------|-------------------------------------------------------------------------------------------------------------------------------------------------------------------------------------------|

High abrasion resistance

| | | | |
|-----------------------------------------------------------------------------------------------------------------------------------------------------------------------------------------------------------------------------------------------------------------------------------------------------|------------------------------------------------------------------------------------------------------------------------------------------------------------------------------------------------------------------------------------------------------------------------------------------------------|---------------------------------------------------------------------------------------------------------------------------------------------------------------------------------------------------------------|----------------------------------------------------------------------------------------------------------------------------------------------------------------------------------------------------|
| <p>SX35TC Good</p> <p>Dab-7 </p> <p><i>No-Skive Multispiral Tough Cover</i> ISO 3862 Type R13 – Parker Specifications</p> | <p>SX42TC Good</p> <p>Dab-10 </p> <p><i>No-Skive Multispiral Tough Cover</i> ISO 3862 Type R15 – Parker Specifications</p> | <p>701TC</p> <p>Dab-12 </p> <p><i>No-Skive Multispiral Tough Cover</i> ISO 3862 Type 4SP – EN 856 Type 4SP</p> | <p>731TC</p> <p>Dab-14 </p> <p><i>No-Skive Multispiral</i> ISO 3862 Type 4SH – EN 856 Type 4SH</p> |
|-----------------------------------------------------------------------------------------------------------------------------------------------------------------------------------------------------------------------------------------------------------------------------------------------------|------------------------------------------------------------------------------------------------------------------------------------------------------------------------------------------------------------------------------------------------------------------------------------------------------|---------------------------------------------------------------------------------------------------------------------------------------------------------------------------------------------------------------|----------------------------------------------------------------------------------------------------------------------------------------------------------------------------------------------------|

Railway

797RH

Dab-16 

No-Skive Compact Spiral™
Fire-retardant cover

Hose

ParLock

Standard

| | | | |
|------------------------------------------------------------------------------------------------------------------------------------------------------------------------------------------------------|------------------------------------------------------------------------------------------------------------------------------------------------------------------------------------------------------|-------------------------------------------------------------------------------------------------------------------------------------------------------------------------------------------------------------|--------------------------------------------------------------------------------------------------------------------------------------------------------------------------------------------------------------|
| <p>H29 Dab-18</p>  <p>ParLock Multispiral Exceeds ISO 3862 Type 4SH – EN 856 Type 4SH</p> | <p>H31 Dab-21</p>  <p>ParLock Multispiral Exceeds ISO 3862 Type 4SP – EN 856 Type 4SP</p> | <p>R35 Dab-24</p>  <p>ParLock Multispiral Exceeds ISO 3862 Type R13 – Parker Specifications</p> | <p>R42 Dab-26</p>  <p>ParLock Multispiral Exceeds ISO 3862 Type R15 – Parker Specifications</p> |
|------------------------------------------------------------------------------------------------------------------------------------------------------------------------------------------------------|------------------------------------------------------------------------------------------------------------------------------------------------------------------------------------------------------|-------------------------------------------------------------------------------------------------------------------------------------------------------------------------------------------------------------|--------------------------------------------------------------------------------------------------------------------------------------------------------------------------------------------------------------|

High abrasion resistance

| | | | |
|--------------------------------------------------------------------------------------------------------------------------------------------------------------------------------------------------------------------|--------------------------------------------------------------------------------------------------------------------------------------------------------------------------------------------------------|-------------------------------------------------------------------------------------------------------------------------------------------------------------------------------------------------------------------------|----------------------------------------------------------------------------------------------------------------------------------------------------------------------------------------------------------------|
| <p>H29TC Dab-19</p>  <p>ParLock Multispiral Exceeds ISO 3862 Type 4SH – EN 856 Type 4SH</p> | <p>H31TC Dab-22</p>  <p>ParLock Multispiral Exceeds ISO 3862 Type 4SP – EN 856 Type 4SP</p> | <p>R35TC/RS35TC-48 Dab-25</p>  <p>ParLock Multispiral Exceeds ISO 3862 Type R13 – Parker Specifications</p> | <p>R42TC Dab-27</p>  <p>ParLock Multispiral Exceeds ISO 3862 Type R15 – Parker Specifications</p> |
| <p>R50TC/R56TC Dab-29</p>  <p>ParLock Multispiral Exceeds ISO 3862 Type R15 – Parker Specifications</p> | <p>RD35TC Dab-32</p>  <p>ParLock Multispiral Drilling Application API 7K Grade D/ISO 14693</p> | <p>CEM69TC Dab-33</p>  <p>Parlock Multispiral Cementing Hose According to API 7K</p> | |

Extreme abrasion resistance

| | | |
|----------------------------------------------------------------------------------------------------------------------------------------------------------------------------------------------------------|----------------------------------------------------------------------------------------------------------------------------------------------------------------------------------------------------------|-----------------------------------------------------------------------------------------------------------------------------------------------------------------------------------------------------------------|
| <p>H29ST Dab-20</p>  <p>ParLock Multispiral Exceeds ISO 3862 Type 4SH – EN 856 Type 4SH</p> | <p>H31ST Dab-23</p>  <p>ParLock Multispiral Exceeds ISO 3862 Type 4SP – EN 856 Type 4SP</p> | <p>R42ST Dab-28</p>  <p>ParLock Multispiral Exceeds ISO 3862 Type R15 – Parker Specifications</p> |
|----------------------------------------------------------------------------------------------------------------------------------------------------------------------------------------------------------|----------------------------------------------------------------------------------------------------------------------------------------------------------------------------------------------------------|-----------------------------------------------------------------------------------------------------------------------------------------------------------------------------------------------------------------|

Water-Blasting

BPK
Dab-30



Blastopak ParLock Multispiral
DIN EN 1829-2

Firearmor Blowout Preventer

FA35
Dab-31



**ParLock Multispiral Firearmor Blowout
Preventer Application**
Meets API 16D – Lloyd's 1000/499 fire test

High Pressure
3-braids low temperature

Parkrimp No-Skive Hose
371LT

371LT

No-Skive Compact

3-wire braid low-temperature compact hose with 4SP working pressures

Primary Applications

Mobile applications in low temperature environments:
Forestry machines, refrigerated warehouses

Applicable Specifications

Parker Specification

Construction

Inner tube: Synthetic rubber
Reinforcement: Three high-tensile steel wire braids
Cover: Synthetic rubber

Temperature Range -50 °C up to +100 °C

Exception: Air max. +70 °C
Water max. +85 °C



- *No-Skive* hose construction – Compact design
- Excellent ozone resistance
- Temperature range from -50 °C up to +100 °C

Recommended Fluids

Hydraulic fluids on a mineral-oil basis, water-glycol and lubricating oils, air and water. For air and gas applications with a pressure exceeding 1.7 MPa, the cover must be pin-pricked. Consult the chemical compatibility section on pages **Ab-26** to **Ab-34** for more detailed information.

Fitting Series



| Part Number | Hose I.D. | | | | Hose O.D. mm | Pressure Rating | | | | min. bend radius mm | weight kg |
|-------------|-----------|------|------|------|-----------------|------------------------------|------|----------------------------|-------|------------------------|--------------|
| | DN | Inch | Size | mm | | max. working pressure MPa | psi | min. burst pressure MPa | psi | | |
| 371LT-6 | 10 | 3/8 | -6 | 9.5 | 21.4 | 44.5 | 6500 | 178.0 | 25800 | 120 | 0.73 |
| 371LT-8 | 12 | 1/2 | -8 | 12.7 | 24.6 | 41.5 | 6000 | 166.0 | 24000 | 160 | 0.90 |
| 371LT-10 | 16 | 5/8 | -10 | 15.9 | 28.2 | 35.0 | 5000 | 140.0 | 20000 | 210 | 1.09 |
| 371LT-12 | 19 | 3/4 | -12 | 19.1 | 32.2 | 35.0 | 5000 | 140.0 | 20000 | 260 | 1.36 |
| 371LT-16 | 25 | 1 | -16 | 25.4 | 39.7 | 28.0 | 4000 | 112.0 | 16000 | 310 | 1.78 |

The combination of high temperature and high pressure could reduce the hose life.

Hose layline example

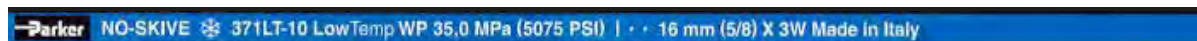

Dab-1

Catalogue 4400/UK

Parkrimp Hose

High Pressure
3-braids standard

Parkrimp No-Skive Hose
372

372

No-Skive Compact

3-wire braid compact hose with
4SP working pressures

Primary Applications

General high pressure small bending radii hydraulic applications

Type Approvals

Details please find on pages **Ab-16** to **Ab-19**

Applicable Specifications

Parker Specification

Construction

Inner tube: Nitrile (NBR)
Reinforcement: Three high-tensile steel wire braids
Cover: Synthetic rubber

Temperature Range -40 °C up to +100 °C

Exception: Air max. +70 °C
Water max. +85 °C



- **No-Skive** hose construction – Compact design
- Nitrile (NBR) inner tube for extended fluid compatibility

Recommended Fluids

Hydraulic fluids on a mineral-oil basis, water-glycol and lubricating oils, air and water. For air and gas applications with a pressure exceeding 1.7 MPa, the cover must be pin-pricked. Consult the chemical compatibility section on pages **Ab-26** to **Ab-34** for more detailed information.

Fitting Series



| Part Number | Hose I.D. | | | | Hose O.D. mm | Pressure Rating | | | | min. bend radius mm | weight kg |
|-------------|-----------|------|------|------|-----------------|------------------------------|------|----------------------------|-------|------------------------|--------------|
| | DN | Inch | Size | mm | | max. working pressure MPa | psi | min. burst pressure MPa | psi | | |
| 372-6 | 10 | 3/8 | -6 | 9.5 | 21.4 | 44.5 | 6500 | 178.0 | 25800 | 120 | 0.73 |
| 372-8 | 12 | 1/2 | -8 | 12.7 | 24.6 | 41.5 | 6000 | 166.0 | 24000 | 160 | 0.90 |
| 372-10 | 16 | 5/8 | -10 | 15.9 | 28.2 | 35.0 | 5000 | 140.0 | 20000 | 210 | 1.09 |
| 372-12 | 19 | 3/4 | -12 | 19.1 | 32.2 | 35.0 | 5000 | 140.0 | 20000 | 260 | 1.36 |
| 372-16 | 25 | 1 | -16 | 25.4 | 39.7 | 28.0 | 4000 | 112.0 | 16000 | 310 | 1.78 |

The combination of high temperature and high pressure could reduce the hose life.

Hose layline example



Dab-2

Catalogue 4400/UK

High Pressure
3-braids railway

Parkrimp No-Skive Hose
372RH

372RH

No-Skive Compact

3-wire braid with fire-retardant cover

Primary Applications

Dynamic and static high-pressure hydraulic systems

Type Approvals

Details please find on pages **Ab-16** to **Ab-19**

Applicable Specifications

Parker Specification

Working pressure and O.D. to EN 856-4SP

Construction

Inner tube: Nitrile (NBR)

Reinforcement: Three high-tensile steel wire braids

Cover: Fire retardant synthetic rubber

Temperature Range -40 °C up to +100 °C

Exception: Air max. +70 °C

Water max. +85 °C



- **No-Skive** hose construction
- Nitrile (NBR) inner tube – high chemical resistance
- Small bend radii
- Fire-retardant cover
- Railway approved:
 - European Standard EN45545 HL3 for R22 (internal) and R23 (external)
 - ISO 15540

Recommended Fluids

Hydraulic fluids on a mineral-oil basis, water-glycol and lubricating oils, air and water. For air and gas applications with a pressure exceeding 1.7 MPa, the cover must be pin-pricked. Consult the chemical compatibility section on pages **Ab-26** to **Ab-34** for more detailed information.

Fitting Series



| Part Number | Hose I.D. | | | | Hose O.D. mm | Pressure Rating | | | | min. bend radius mm | weight kg |
|-------------|-----------|------|------|------|-----------------|------------------------------|------|----------------------------|-------|------------------------|--------------|
| | DN | Inch | Size | mm | | max. working pressure MPa | psi | min. burst pressure MPa | psi | | |
| 372RH-6 | 10 | 3/8 | -6 | 9.5 | 21.4 | 44.5 | 6500 | 178.0 | 25800 | 120 | 0.73 |
| 372RH-8 | 12 | 1/2 | -8 | 12.7 | 24.6 | 41.5 | 6000 | 166.0 | 24000 | 160 | 0.90 |
| 372RH-10 | 16 | 5/8 | -10 | 15.9 | 28.2 | 35.0 | 5000 | 140.0 | 20000 | 210 | 1.09 |
| 372RH-12 | 19 | 3/4 | -12 | 19.1 | 32.2 | 35.0 | 5000 | 140.0 | 20000 | 260 | 1.36 |
| 372RH-16 | 25 | 1 | -16 | 25.4 | 39.7 | 28.0 | 4000 | 112.0 | 16000 | 310 | 1.78 |

The combination of high temperature and high pressure could reduce the hose life.

Hose layline example



Dab-3

Catalogue 4400/UK

Parkrimp Hose

High Pressure
3-braids high abrasion resistance

Parkrimp No-Skive Hose
372TC

372TC

No-Skive Compact

3-wire braid compact hose with 4SP working pressures

Primary Applications

General high pressure hydraulic applications (typically in the mobile industry)

Type Approvals

Details please find on pages **Ab-16** to **Ab-19**

Applicable Specifications

Parker Specification – working pressures and outside diameters according to EN 856-4SP

Construction

Inner tube: Nitrile (NBR)
Reinforcement: Three high-tensile steel wire braids
Cover: Highly abrasion resistance
MSHA approved synthetic rubber

Temperature Range -40 °C up to +100 °C

Exception: Air max. +70 °C
Water max. +85 °C



- **No-Skive** hose construction – Compact design
- Nitrile (NBR) inner tube for greater fluid compatibility
- Highly abrasion resistant **TOUGH COVER**
- MSHA approved
- Hose is suitable for temporary immersion in mineral oil up to 70 °C with frequent inspections

Recommended Fluids

Hydraulic fluids on a mineral-oil basis, water-glycol and lubricating oils, air and water. For air and gas applications with a pressure exceeding 1.7 MPa, the cover must be pin-pricked. Consult the chemical compatibility section on pages **Ab-26** to **Ab-34** for more detailed information.

Fitting Series



| Part Number | Hose I.D. | | | | Hose O.D. mm | Pressure Rating | | | | min. bend radius mm | weight kg |
|-------------|-----------|------|------|------|-----------------|------------------------------|------|----------------------------|-------|------------------------|--------------|
| | DN | Inch | Size | mm | | max. working pressure MPa | psi | min. burst pressure MPa | psi | | |
| 372TC-6 | 10 | 3/8 | -6 | 9.5 | 21.4 | 44.5 | 6500 | 178.0 | 25800 | 120 | 0.73 |
| 372TC-8 | 12 | 1/2 | -8 | 12.7 | 24.6 | 41.5 | 6000 | 166.0 | 24000 | 160 | 0.90 |
| 372TC-10 | 16 | 5/8 | -10 | 15.9 | 28.2 | 35.0 | 5000 | 140.0 | 20000 | 210 | 1.09 |
| 372TC-12 | 19 | 3/4 | -12 | 19.1 | 32.2 | 35.0 | 5000 | 140.0 | 20000 | 260 | 1.36 |
| 372TC-16 | 25 | 1 | -16 | 25.4 | 39.7 | 28.0 | 4000 | 112.0 | 16000 | 310 | 1.78 |

Replace the hose when any deformation or damage on the hose cover are visible. The combination of high temperature and high pressure could reduce the hose life.

Hose layline example



Dab-4

Catalogue 4400/UK

SX35

No-Skive Multispiral

ISO 3862 Type R13 – Parker Specifications



- **No-Skive** hose construction
- High performance
- Reinforcement of four spiral high-tensile steel wire
- Constant working pressure of 35.0 MPa
- Temperature range up to +125 °C

Primary Applications

General high pressure hydraulic applications

Applicable Specifications

ISO 3862 Type R13 – Parker Specification

Construction

Inner tube: Synthetic rubber
Reinforcement: Four spiral high-tensile steel wire
Cover: Synthetic rubber

Temperature Range -40 °C up to +125 °C

Exception: Air max. +70 °C
Water max. +85 °C

Recommended Fluids

Hydraulic fluids on a mineral-oil basis, water-glycol and lubricating oils, air and water. For air and gas applications with a pressure exceeding 1.7 MPa, the cover must be pin-pricked. Consult the chemical compatibility section on pages **Ab-26** to **Ab-34** for more detailed information.

Fitting Series



| Part Number | Hose I.D. | | | | Hose O.D. mm | Pressure Rating | | | | min. bend radius mm | weight kg |
|-------------|-----------|-------|------|------|-----------------|------------------------------|------|----------------------------|-------|------------------------|--------------|
| | DN | Inch | Size | mm | | max. working pressure MPa | psi | min. burst pressure MPa | psi | | |
| SX35-12 | 20 | 3/4 | -12 | 19.1 | 32.4 | 35.0 | 5000 | 140.0 | 20000 | 240 | 1.72 |
| SX35-16 | 25 | 1 | -16 | 25.4 | 38.2 | 35.0 | 5000 | 140.0 | 20000 | 300 | 2.14 |
| SX35-20 | 32 | 1 1/4 | -20 | 31.5 | 46.3 | 35.0 | 5000 | 140.0 | 20000 | 420 | 2.96 |

The combination of high temperature and high pressure could reduce the hose life.

Hose layline example



High Pressure
Low/High temperature

Parkrimp No-Skive Hose
SX35LT

SX35LT

No-Skive Multispiral
Parker Specification

Primary Applications

General high pressure hydraulic applications for very low temperature environments

Applicable Specifications

Parker Specification

Construction

Inner tube: Synthetic rubber
Reinforcement: Four high-tensile steel wires
Cover: Synthetic rubber

Temperature Range -57 °C up to +100 °C

Exception: Air max. +70 °C
Water max. +85 °C

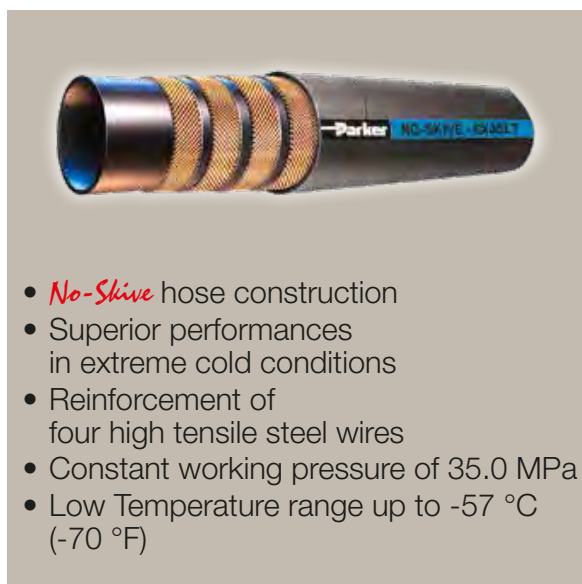

- *No-Skive* hose construction
- Superior performances in extreme cold conditions
- Reinforcement of four high tensile steel wires
- Constant working pressure of 35.0 MPa
- Low Temperature range up to -57 °C (-70 °F)

Recommended Fluids

Hydraulic fluids on a mineral-oil basis, water-glycol and lubricating oils, air and water. For air and gas applications with a pressure exceeding 1.7 MPa, the cover must be pin-pricked. Consult the chemical compatibility section on pages **Ab-26** to **Ab-34** for more detailed information.

Fitting Series



| Part Number | Hose I.D. | | | | Hose O.D. mm | Pressure Rating | | | | min. bend radius mm | weight kg |
|-------------|-----------|-------|------|------|-----------------|------------------------------|------|----------------------------|-------|------------------------|--------------|
| | DN | Inch | Size | mm | | max. working pressure MPa | psi | min. burst pressure MPa | psi | | |
| SX35LT-12 | 20 | 3/4 | -12 | 19.1 | 32.4 | 35.0 | 5000 | 140.0 | 20000 | 240 | 1.72 |
| SX35LT-16 | 25 | 1 | -16 | 25.4 | 38.2 | 35.0 | 5000 | 140.0 | 20000 | 300 | 2.14 |
| SX35LT-20 | 32 | 1 1/4 | -20 | 31.5 | 46.3 | 35.0 | 5000 | 140.0 | 20000 | 420 | 2.96 |

The combination of high temperature and high pressure could reduce the hose life.

Hose layline example



Dab-6

Catalogue 4400/UK

High Pressure
High abrasion resistance

Parkrimp No-Skive Hose

SX35TC

No-Skive Multispiral Tough Cover

ISO 3862 Type R13 – Parker Specifications



- *No-Skive* hose construction
- High performance
- Highly abrasion resistant **TOUGH COVER**
- MSHA approved
- Reinforcement of four spiral high-tensile steel wire
- Constant working pressure of 35.0 MPa
- Temperature range up to +125 °C

Primary Applications

General high pressure hydraulic applications

Applicable Specifications

ISO 3862 Type R13 – Parker Specification

Construction

Inner tube: Synthetic rubber
Reinforcement: Four spiral high-tensile steel wire
Cover: Highly abrasion resistance
MSHA approved synthetic rubber

Temperature Range -40 °C up to +125 °C

Exception: Air max. +70 °C
Water max. +85 °C

Recommended Fluids

Hydraulic fluids on a mineral-oil basis, water-glycol and lubricating oils, air and water. For air and gas applications with a pressure exceeding 1.7 MPa, the cover must be pin-pricked. Consult the chemical compatibility section on pages **Ab-26** to **Ab-34** for more detailed information.

Fitting Series



| Part Number | Hose I.D. | | | | Hose O.D. mm | Pressure Rating | | | | min. bend radius mm | weight kg |
|-------------|-----------|-------|------|------|-----------------|------------------------------|------|----------------------------|-------|------------------------|--------------|
| | DN | Inch | Size | mm | | max. working pressure MPa | psi | min. burst pressure MPa | psi | | |
| SX35TC-12 | 20 | 3/4 | -12 | 19.1 | 32.4 | 35.0 | 5000 | 140.0 | 20000 | 240 | 1.72 |
| SX35TC-16 | 25 | 1 | -16 | 25.4 | 38.2 | 35.0 | 5000 | 140.0 | 20000 | 300 | 2.14 |
| SX35TC-20 | 32 | 1 1/4 | -20 | 31.5 | 46.3 | 35.0 | 5000 | 140.0 | 20000 | 420 | 2.96 |

The combination of high temperature and high pressure could reduce the hose life.

Hose layline example

Parker NO-SKIVE - SX35TC-12 WP 35,0 MPa (5000 PSI) 1" ISO 3862 4SP / R13 - 19 mm (3/4") MADE IN ITALY



Dab-7

Catalogue 4400/UK

Parkrimp Hose

SX42

No-Skive Multispiral

ISO 3862 Type R15 – Parker Specifications



- *No-Skive* hose construction
- High performance
- Reinforcement of four or six spiral high-tensile steel wire
- Constant working pressure of 42.0 MPa
- Temperature range up to +125 °C

Primary Applications

General high pressure hydraulic applications

Applicable Specifications

ISO 3862 Type R15 – Parker Specification

Construction

Inner tube: Synthetic rubber
Reinforcement: Four or six spiral high-tensile steel wire
Cover: Synthetic rubber

Temperature Range -40 °C up to +125 °C

Exception: Air max. +70 °C
Water max. +85 °C

Recommended Fluids

Hydraulic fluids on a mineral-oil basis, water-glycol and lubricating oils, air and water. For air and gas applications with a pressure exceeding 1.7 MPa, the cover must be pin-pricked. Consult the chemical compatibility section on pages **Ab-26** to **Ab-34** for more detailed information.

Fitting Series

Size -12

Size -16 and -20



| Part Number | Hose I.D. | | | | Hose O.D. mm | Pressure Rating | | | | min. bend radius mm | weight kg |
|-------------|-----------|-------|------|------|-----------------|------------------------------|------|----------------------------|-------|------------------------|--------------|
| | DN | Inch | Size | mm | | max. working pressure MPa | psi | min. burst pressure MPa | psi | | |
| SX42-12 | 20 | 3/4 | -12 | 19.1 | 32.4 | 42.0 | 6000 | 168.0 | 24000 | 260 | 1.72 |
| SX42-16 | 25 | 1 | -16 | 25.4 | 38.2 | 42.0 | 6000 | 168.0 | 24000 | 330 | 1.74 |
| SX42-20 | 32 | 1 1/4 | -20 | 31.5 | 46.3 | 42.0 | 6000 | 168.0 | 24000 | 400 | 2.98 |

The combination of high temperature and high pressure could reduce the hose life.

Hose layline example



High Pressure
Low/High temperature

Parkrimp No-Skive Hose
SX42LT

SX42LT

No-Skive Multispiral
Parker Specification



- *No-Skive* hose construction
- Superior performances in extreme cold conditions
- Reinforcement of four or six high tensile steel wires
- Constant working pressure of 42.0 MPa
- Low Temperature range up to -57 °C (-70 °F)

Primary Applications

General high pressure hydraulic applications for very low temperature environments

Applicable Specifications

Parker Specification

Construction

Inner tube: Synthetic rubber
Reinforcement: Four or six spiral high-tensile steel wires
Cover: Synthetic rubber

Temperature Range -57 °C up to +100 °C

Exception: Air max. +70 °C
Water max. +85 °C

Recommended Fluids

Hydraulic fluids on a mineral-oil basis, water-glycol and lubricating oils, air and water. For air and gas applications with a pressure exceeding 1.7 MPa, the cover must be pin-pricked. Consult the chemical compatibility section on pages **Ab-26** to **Ab-34** for more detailed information.

Fitting Series

Size -12

Size -16 and -20



| Part Number | Hose I.D. | | | | Hose O.D. mm | Pressure Rating | | | | min. bend radius mm | weight kg |
|-------------|-----------|-------|------|------|-----------------|------------------------------|------|----------------------------|-------|------------------------|--------------|
| | DN | Inch | Size | mm | | max. working pressure MPa | psi | min. burst pressure MPa | psi | | |
| SX42LT-12 | 20 | 3/4 | -12 | 19.1 | 32.4 | 42.0 | 6000 | 168.0 | 24000 | 260 | 1.72 |
| SX42LT-16 | 25 | 1 | -16 | 25.4 | 38.2 | 42.0 | 6000 | 168.0 | 24000 | 330 | 1.74 |
| SX42LT-20 | 32 | 1 1/4 | -20 | 31.5 | 46.3 | 42.0 | 6000 | 168.0 | 24000 | 400 | 2.98 |

The combination of high temperature and high pressure could reduce the hose life.

Parkrimp Hose

Hose layline example



Dab-9

Catalogue 4400/UK

High Pressure
High abrasion resistance

Parkrimp No-Skive Hose

SX42TC

No-Skive **Multispiral Tough Cover**

ISO 3862 Type R15 – Parker Specifications



- *No-Skive* hose construction
- High performance
- Highly abrasion resistant **TOUGH COVER**
- MSHA approved
- Reinforcement of four or six spiral high-tensile steel wire
- Constant working pressure of 42.0 MPa
- Temperature range up to +125 °C

Primary Applications

General high pressure hydraulic applications

Applicable Specifications

ISO 3862 Type R15 – Parker Specification

Construction

Inner tube: Synthetic rubber
Reinforcement: Four or six spiral high-tensile steel wire
Cover: Highly abrasion resistance
MSHA approved synthetic rubber

Temperature Range -40 °C up to +125 °C

Exception: Air max. +70 °C
Water max. +85 °C

Recommended Fluids

Hydraulic fluids on a mineral-oil basis, water-glycol and lubricating oils, air and water. For air and gas applications with a pressure exceeding 1.7 MPa, the cover must be pin-pricked. Consult the chemical compatibility section on pages **Ab-26** to **Ab-34** for more detailed information.

Fitting Series

Size -12

Size -16 and -20



| Part Number | Hose I.D. | | | | Hose O.D. mm | Pressure Rating | | | | min. bend radius mm | weight kg |
|-------------|-----------|-------|------|------|-----------------|------------------------------|------|----------------------------|-------|------------------------|--------------|
| | DN | Inch | Size | mm | | max. working pressure MPa | psi | min. burst pressure MPa | psi | | |
| SX42TC-12 | 20 | 3/4 | -12 | 19.1 | 32.4 | 42.0 | 6000 | 168.0 | 24000 | 260 | 1.72 |
| SX42TC-16 | 25 | 1 | -16 | 25.4 | 38.2 | 42.0 | 6000 | 168.0 | 24000 | 330 | 1.74 |
| SX42TC-20 | 32 | 1 1/4 | -20 | 31.5 | 46.3 | 42.0 | 6000 | 168.0 | 24000 | 400 | 2.98 |

The combination of high temperature and high pressure could reduce the hose life.

Hose layline example



Dab-10

Catalogue 4400/UK

701

No-Skive Multispiral

Exceeds ISO 3862 Type 4SP –
EN 856 Type 4SP



- *No-Skive* hose construction
- Reinforcement of four spiral high-tensile steel wire

Primary Applications

General high pressure hydraulic applications

Type Approvals

Details please find on pages **Ab-16** to **Ab-19**

Applicable Specifications

Exceed ISO 3862 Type 4SP – EN 856 Type 4SP

Construction

Inner tube: Synthetic rubber
Reinforcement: Four spiral high-tensile steel wire
Cover: Synthetic rubber

Temperature Range -40 °C up to +100 °C

Exception: Air max. +70 °C
Water max. +85 °C

Recommended Fluids

Hydraulic fluids on a mineral-oil basis, water-glycol and lubricating oils, air and water. For air and gas applications with a pressure exceeding 1.7 MPa, the cover must be pin-pricked. Consult the chemical compatibility section on pages **Ab-26** to **Ab-34** for more detailed information.

Fitting Series



| Part Number | Hose I.D. | | | | Hose O.D. mm | Pressure Rating | | | | min. bend radius mm | weight kg |
|-------------|-----------|------|------|------|-----------------|------------------------------|------|----------------------------|-------|------------------------|--------------|
| | DN | Inch | Size | mm | | max. working pressure MPa | psi | min. burst pressure MPa | psi | | |
| 701-6 | 10 | 3/8 | -6 | 9.5 | 21.4 | 45.0 | 6500 | 180.0 | 26000 | 180 | 0.78 |
| 701-8 | 12 | 1/2 | -8 | 12.7 | 24.6 | 41.5 | 6000 | 166.0 | 24000 | 230 | 0.93 |
| 701-10 | 16 | 5/8 | -10 | 15.9 | 28.2 | 35.0 | 5000 | 140.0 | 20000 | 250 | 1.15 |
| 701-12 | 19 | 3/4 | -12 | 19.1 | 32.2 | 35.0 | 5000 | 140.0 | 20000 | 300 | 1.58 |
| 701-16 | 25 | 1 | -16 | 25.4 | 39.7 | 28.0 | 4000 | 112.0 | 16000 | 340 | 2.04 |

The combination of high temperature and high pressure could reduce the hose life.

Parkrimp Hose

Hose layline example



High Pressure
High abrasion resistance

Parkrimp No-Skive Hose
701TC

701TC

No-Skive Multispiral Tough Cover
ISO 3862 Type 4SP – EN 856 Type 4SP



- *No-Skive* hose construction
- Reinforcement of four spiral high-tensile steel wire
- Highly abrasion resistant **TOUGH COVER**
- MSHA approved
- Hose is suitable for temporary immersion in mineral oil up to 70 °C with frequent inspections

Primary Applications

General high pressure hydraulic applications

Type Approvals

Details please find on pages **Ab-16** to **Ab-19**

Applicable Specifications

ISO 3862 Type 4SP – EN 856 Type 4SP

Construction

Inner tube: Synthetic rubber
Reinforcement: Four spiral high-tensile steel wire
Cover: Highly abrasion resistance
MSHA approved synthetic rubber

Recommended Fluids

Hydraulic fluids on a mineral-oil basis, water-glycol and lubricating oils, air and water. For air and gas applications with a pressure exceeding 1.7 MPa, the cover must be pin-pricked. Consult the chemical compatibility section on pages **Ab-26** to **Ab-34** for more detailed information.

Temperature Range -40 °C up to +100 °C

Exception: Air max. +70 °C
Water max. +85 °C

Fitting Series



| Part Number | Hose I.D. | | | | Hose O.D. mm | Pressure Rating | | | | min. bend radius mm | weight kg |
|-------------|-----------|------|------|------|-----------------|------------------------------|------|----------------------------|-------|------------------------|--------------|
| | DN | Inch | Size | mm | | max. working pressure MPa | psi | min. burst pressure MPa | psi | | |
| 701TC-6 | 10 | 3/8 | -6 | 9.5 | 21.4 | 45.0 | 6500 | 180.0 | 26000 | 180 | 0.78 |
| 701TC-8 | 12 | 1/2 | -8 | 12.7 | 24.6 | 41.5 | 6000 | 166.0 | 24000 | 230 | 0.93 |
| 701TC-10 | 16 | 5/8 | -10 | 15.9 | 28.2 | 35.0 | 5000 | 140.0 | 20000 | 250 | 1.15 |
| 701TC-12 | 19 | 3/4 | -12 | 19.1 | 32.2 | 35.0 | 5000 | 140.0 | 20000 | 300 | 1.58 |
| 701TC-16 | 25 | 1 | -16 | 25.4 | 39.7 | 28.0 | 4000 | 112.0 | 16000 | 340 | 2.04 |

The combination of high temperature and high pressure could reduce the hose life.

Hose layline example

NO-SKIVE 701TC-12 WP 35,0 MPa (5000 PSI) MSHA XXXX 19 mm (3/4) X 4S EN 856-4SP/20/4Q91



Dab-12

Catalogue 4400/UK

731

No-Skive Multispiral

Exceeds ISO 3862 Type 4SH –
EN 856 Type 4SH



- *No-Skive* hose construction
- Reinforcement of four spiral high-tensile steel wire

Primary Applications

General high pressure hydraulic applications

Applicable Specifications

Exceed ISO 3862 Type 4SH – EN 856 Type 4SH

Construction

Inner tube: Synthetic rubber
Reinforcement: Four spiral high-tensile steel wire
Cover: Synthetic rubber

Temperature Range -40 °C up to +100 °C

Exception: Air max. +70 °C
Water max. +85 °C

Recommended Fluids

Hydraulic fluids on a mineral-oil basis, water-glycol and lubricating oils, air and water. For air and gas applications with a pressure exceeding 1.7 MPa, the cover must be pin-pricked. Consult the chemical compatibility section on pages **Ab-26** to **Ab-34** for more detailed information.

Fitting Series



| Part Number | Hose I.D. | | | | Hose O.D. mm | Pressure Rating | | | | min. bend radius mm | weight kg |
|-------------|-----------|-------|------|------|-----------------|------------------------------|------|----------------------------|-------|------------------------|--------------|
| | DN | Inch | Size | mm | | max. working pressure MPa | psi | min. burst pressure MPa | psi | | |
| 731-12 | 19 | 3/4 | -12 | 19.1 | 32.0 | 42.0 | 6000 | 168.0 | 24000 | 280 | 1.72 |
| 731-16 | 25 | 1 | -16 | 25.4 | 39.0 | 38.0 | 5500 | 152.0 | 22000 | 340 | 2.14 |
| 731-20 | 31 | 1 1/4 | -20 | 31.8 | 45.0 | 32.5 | 4700 | 130.0 | 18800 | 460 | 2.96 |
| 731-24 | 38 | 1 1/2 | -24 | 38.1 | 53.0 | 29.0 | 4200 | 116.0 | 16800 | 560 | 3.20 |
| 731-32 | 51 | 2 | -32 | 50.8 | 68.0 | 25.0 | 3600 | 100.0 | 14400 | 700 | 5.30 |

The combination of high temperature and high pressure could reduce the hose life.

Hose layline example

NO-SKIVE 731-12 WP 42,0 MPa (6000 PSI) MSHA XXXX 19 mm (3/4) X 4S EN 856-4SH/20/4Q91



High Pressure
High abrasion resistance

Parkrimp No-Skive Hose
731TC

731TC

No-Skive Multispiral

ISO 3862 Type 4SH – EN 856 Type 4SH



- **No-Skive** hose construction
- Reinforcement of four spiral high-tensile steel wire
- Highly abrasion resistant **TOUGH COVER**
- MSHA approved
- Hose is suitable for temporary immersion in mineral oil up to 70 °C with frequent inspections

Primary Applications

General high pressure hydraulic applications

Type Approvals

Details please find on pages **Ab-16** to **Ab-19**

Applicable Specifications

ISO 3862 Type 4SH – EN 856 Type 4SH

Construction

Inner tube: Synthetic rubber
Reinforcement: Four spiral high-tensile steel wire
Cover: Highly abrasion resistance
MSHA approved synthetic rubber

Recommended Fluids

Hydraulic fluids on a mineral-oil basis, water-glycol and lubricating oils, air and water. For air and gas applications with a pressure exceeding 1.7 MPa, the cover must be pin-pricked. Consult the chemical compatibility section on pages **Ab-26** to **Ab-34** for more detailed information.

Temperature Range -40 °C up to +100 °C

Exception: Air max. +70 °C

Water max. +85 °C

Fitting Series



| Part Number | Hose I.D. | | | | Hose O.D. mm | Pressure Rating | | | | min. bend radius mm | weight kg |
|-------------|-----------|-------|------|------|-----------------|------------------------------|------|----------------------------|-------|------------------------|--------------|
| | DN | Inch | Size | mm | | max. working pressure MPa | psi | min. burst pressure MPa | psi | | |
| 731TC-12 | 19 | 3/4 | -12 | 19.1 | 32.0 | 42.0 | 6000 | 168.0 | 24000 | 280 | 1.72 |
| 731TC-16 | 25 | 1 | -16 | 25.4 | 39.0 | 38.0 | 5500 | 152.0 | 22000 | 340 | 2.14 |
| 731TC-20 | 31 | 1 1/4 | -20 | 31.8 | 45.0 | 32.5 | 4700 | 130.0 | 18800 | 460 | 2.96 |
| 731TC-24 | 38 | 1 1/2 | -24 | 38.1 | 53.0 | 29.0 | 4200 | 116.0 | 16800 | 560 | 3.20 |
| 731TC-32 | 51 | 2 | -32 | 50.8 | 68.0 | 25.0 | 3600 | 100.0 | 14400 | 700 | 5.30 |

Replace the hose when any deformation or damage on the hose cover are visible.
The combination of high temperature and high pressure could reduce the hose life.

Hose layline example

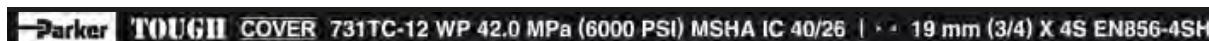

Dab-14

Catalogue 4400/UK

774

No-Skive Multispiral

For phosphate ester base fluids

Primary Applications

Test stands for aerospace, foundries, steel mills
High pressure hydraulic applications with phosphate ester fluids

Restrictions

Do not allow tube to contact any petroleum base fluids.
Use liquid soap as hose lubricant.

Applicable Specifications

Parker Specification

Construction

Inner tube: Phosphate ester resistant
EPDM synthetic rubber
Reinforcement: Four spiral high-tensile steel wire
Cover: EPDM synthetic rubber, green,
phosphate ester and weather resistant

Temperature Range -40 °C up to +80 °C



- *No-Skive* hose construction
- Phosphate ester and weather resistant, green, EPDM synthetic rubber cover

Recommended Fluids

Phosphate ester base hydraulic fluids.
Consult the chemical compatibility section on pages **Ab-26** to **Ab-34** for more detailed information.

Fitting Series

on request

| Part Number | Hose I.D. | | | | Hose O.D. mm | Pressure Rating | | | | min. bend radius mm | weight kg |
|-------------|-----------|-------|------|------|-----------------|------------------------------|------|----------------------------|-------|------------------------|--------------|
| | DN | Inch | Size | mm | | max. working pressure MPa | psi | min. burst pressure MPa | psi | | |
| 774-12 | 19 | 3/4 | -12 | 19.1 | 31.0 | 28.0 | 4000 | 112.0 | 16000 | 240 | 1.40 |
| 774-16 | 25 | 1 | -16 | 25.4 | 38.0 | 28.0 | 4000 | 112.0 | 16000 | 300 | 1.99 |
| 774-20 | 31 | 1 1/4 | -20 | 31.8 | 47.0 | 21.0 | 3000 | 84.0 | 12000 | 420 | 2.59 |
| 774-24 | 38 | 1 1/2 | -24 | 38.1 | 53.0 | 17.5 | 2500 | 70.0 | 10000 | 500 | 2.99 |
| 774-32 | 51 | 2 | -32 | 50.8 | 67.0 | 17.5 | 2500 | 70.0 | 10000 | 630 | 4.09 |

The combination of high temperature and high pressure could reduce the hose life.

Hose layline example

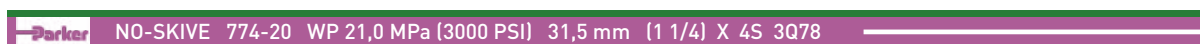

Dab-15

Catalogue 4400/UK

Parkrimp Hose

797RH

No-Skive Compact Spiral™

Fire-retardant cover

Primary Applications

General high pressure hydraulic circuits for railway applications.

Type Approvals

Details please find on pages **Ab-16** to **Ab-19**

Applicable Specifications

Exceed SAE 100R15 - ISO 3862 Type R15 - ISO 18752-DC

Construction

Inner tube: Proprietary synthetic rubber
Reinforcement: Four spiral high-tensile steel wire
Cover: Fire retardant synthetic rubber

Temperature Range -40 °C up to +125 °C

Exception: Air max. +70 °C
Water max. +85 °C



- 1/2 the bend radius of SAE 100R15
- Constant working pressure of 42.0 MPa
- Reduced O.D. and new construction lead to superior flexibility
- 1/3 less effort to bend
- Weight reduction – up to 26 %
- Railway approved:
 - European Standard EN45545 HL2 for R22 (internal) and R23 (external)

Recommended Fluids

Petroleum base hydraulic fluids and lubricating oils.
Wide Compatibility exceeding Column III, with additional chemical resistance, especially for diesel and biodiesel.
Consult the chemical compatibility section on pages **Ab-26** to **Ab-34** for more detailed information.

Fitting Series



| Part Number | Hose I.D. | | | | Hose O.D. mm | Pressure Rating | | | | min. bend radius mm | weight kg |
|-------------|-----------|------|------|------|-----------------|------------------------------|------|----------------------------|-------|------------------------|--------------|
| | DN | Inch | Size | mm | | max. working pressure MPa | psi | min. burst pressure MPa | psi | | |
| 797RH-8 | 12 | 1/2 | -8 | 12.7 | 21.1 | 42.0 | 6000 | 168.0 | 24000 | 100 | 0.67 |
| 797RH-10 | 16 | 5/8 | -10 | 15.9 | 23.9 | 42.0 | 6000 | 168.0 | 24000 | 115 | 0.80 |
| 797RH-12 | 19 | 3/4 | -12 | 19.1 | 27.9 | 42.0 | 6000 | 168.0 | 24000 | 135 | 1.16 |
| 797RH-16 | 25 | 1 | -16 | 25.4 | 35.7 | 42.0 | 6000 | 168.0 | 24000 | 165 | 1.74 |

Replace the hose when any deformation or damage on the hose cover are visible.
The combination of high temperature and high pressure could reduce the hose life.

Hose layline example

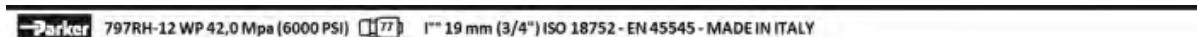

F42

No-Skive Multispiral

For phosphate ester base fluids

Primary Applications

Test stands for aerospace, foundries, steel mills, high pressure hydraulic applications with phosphate ester fluids

Applicable Specifications

Parker Specification

Restrictions

Do not allow tube to contact any petroleum base fluids. Use liquid soap as hose lubricant.

Construction

Inner tube: Phosphate ester resistant EPDM synthetic rubber
Reinforcement: Four or six spiral high-tensile steel wire
Cover: EPDM synthetic rubber, green, phosphate ester and weather resistant

Temperature Range -40 °C up to +80 °C

Exception: Air max. +70 °C
Water max. +85 °C



- **No-Skive** hose construction
- Phosphate ester and weather resistant, green, EPDM synthetic rubber cover
- Constant working pressure of 42.0 MPa

Recommended Fluids

Phosphate ester based hydraulic fluids, water-glycol based fluids, air and water.

Consult the chemical compatibility section on pages **Ab-26** to **Ab-34** for more detailed information.

Fitting Series

on request

| Part Number | Hose I.D. | | | | Hose O.D. mm | Pressure Rating | | | | min. bend radius mm | weight kg |
|-------------|-----------|-------|------|------|-----------------|------------------------------|------|----------------------------|-------|------------------------|--------------|
| | DN | Inch | Size | mm | | max. working pressure MPa | psi | min. burst pressure MPa | psi | | |
| F42-8 | 12 | 1/2 | -8 | 12.7 | 25.0 | 42.0 | 6000 | 168.0 | 24000 | 200 | 0.83 |
| F42-12 | 19 | 3/4 | -12 | 19.1 | 31.9 | 42.0 | 6000 | 168.0 | 24000 | 265 | 1.53 |
| F42-16 | 25 | 1 | -16 | 25.4 | 38.5 | 42.0 | 6000 | 168.0 | 24000 | 330 | 2.08 |
| F42-20 | 31 | 1 1/4 | -20 | 31.8 | 50 | 42.0 | 6000 | 168.0 | 24000 | 445 | 3.96 |

The combination of high temperature and high pressure could reduce the hose life.

Hose layline example

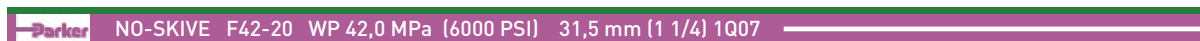

Dab-17

Catalogue 4400/UK

Parkrimp Hose

H29

ParLock Multispiral

Exceeds ISO 3862 Type 4SH –
EN 856 Type 4SH

Primary Applications

General high pressure hydraulic applications

Type Approvals

Details please find on pages **Ab-16** to **Ab-19**

Applicable Specifications

Exceed ISO 3862 Type 4SH – EN 856 Type 4SH

Construction

Inner tube: Synthetic rubber
Reinforcement: Four spiral high-tensile steel wire
Cover: Synthetic rubber

Temperature Range -40 °C up to +100 °C

Exception: Air max. +70 °C
Water max. +85 °C

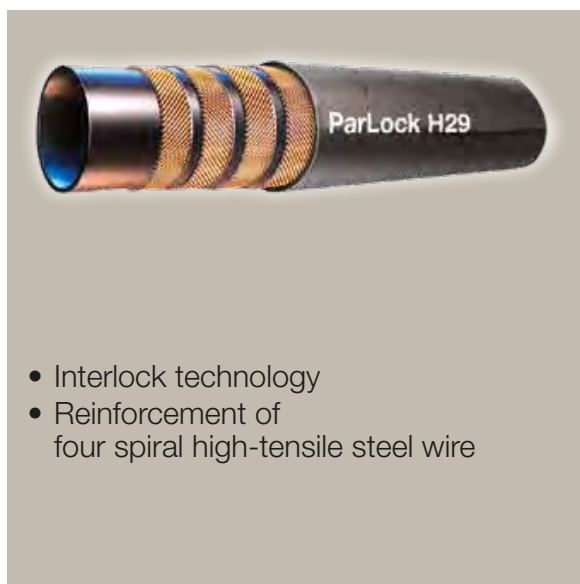

- Interlock technology
- Reinforcement of four spiral high-tensile steel wire

Recommended Fluids

Hydraulic fluids on a mineral-oil basis, water-glycol and lubricating oils, air and water. For air and gas applications with a pressure exceeding 1.7 MPa, the cover must be pin-pricked. Consult the chemical compatibility section on pages **Ab-26** to **Ab-34** for more detailed information.

Fitting Series

Internal and external skiving



| Part Number | Hose I.D. | | | | Hose O.D. mm | Pressure Rating | | | | min. bend radius mm | weight kg |
|-------------|-----------|-------|------|------|-----------------|------------------------------|------|----------------------------|-------|------------------------|--------------|
| | DN | Inch | Size | mm | | max. working pressure MPa | psi | min. burst pressure MPa | psi | | |
| H29-12 | 19 | 3/4 | -12 | 19.1 | 32.2 | 43.0 | 6250 | 172.0 | 25000 | 280 | 1.7 |
| H29-16 | 25 | 1 | -16 | 25.4 | 38.7 | 40.0 | 5800 | 160.0 | 23200 | 340 | 2.2 |
| H29-20 | 31 | 1 1/4 | -20 | 31.8 | 45.5 | 35.0 | 5000 | 140.0 | 20000 | 460 | 2.6 |
| H29-24 | 38 | 1 1/2 | -24 | 38.1 | 53.5 | 31.0 | 4500 | 124.0 | 18000 | 560 | 3.4 |
| H29-32 | 51 | 2 | -32 | 50.8 | 68.1 | 28.0 | 4050 | 112.0 | 16200 | 700 | 4.8 |

The combination of high temperature and high pressure could reduce the hose life.

Hose layline example

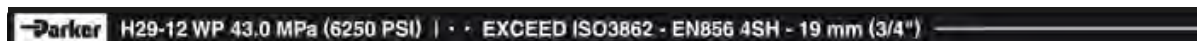

High Pressure
High abrasion resistance

ParLock Hose
H29TC

H29TC

ParLock Multispiral

Exceeds ISO 3862 Type 4SH – EN 856 Type 4SH



- Interlock technology
- Reinforcement of four spiral high-tensile steel wire
- Highly abrasion resistant **TOUGH COVER**
- MSHA approved
- Hose is suitable for temporary immersion in mineral oil up to 70 °C with frequent inspections

Primary Applications

General high pressure hydraulic applications

Type Approvals

Details please find on pages **Ab-16** to **Ab-19**

Applicable Specifications

Exceed ISO 3862 Type 4SH – EN 856 Type 4SH

Construction

Inner tube: Synthetic rubber
Reinforcement: Four spiral high-tensile steel wire
Cover: Highly abrasion resistance
MSHA approved synthetic rubber

Temperature Range -40 °C up to +100 °C

Exception: Air max. +70 °C

Water max. +85 °C

Recommended Fluids

Hydraulic fluids on a mineral-oil basis, water-glycol and lubricating oils, air and water. For air and gas applications with a pressure exceeding 1.7 MPa, the cover must be pin-pricked. Consult the chemical compatibility section on pages **Ab-26** to **Ab-34** for more detailed information.

Fitting Series

Internal and external skiving



| Part Number | Hose I.D. | | | | Hose O.D. mm | Pressure Rating | | | | min. bend radius mm | weight kg |
|-------------|-----------|-------|------|------|-----------------|------------------------------|------|----------------------------|-------|------------------------|--------------|
| | DN | Inch | Size | mm | | max. working pressure MPa | psi | min. burst pressure MPa | psi | | |
| H29TC-12 | 19 | 3/4 | -12 | 19.1 | 32.2 | 43.0 | 6250 | 172.0 | 25000 | 280 | 1.7 |
| H29TC-16 | 25 | 1 | -16 | 25.4 | 38.7 | 40.0 | 5800 | 160.0 | 23200 | 340 | 2.2 |
| H29TC-20 | 31 | 1 1/4 | -20 | 31.8 | 45.5 | 35.0 | 5000 | 140.0 | 20000 | 460 | 2.6 |
| H29TC-24 | 38 | 1 1/2 | -24 | 38.1 | 53.5 | 31.0 | 4500 | 124.0 | 18000 | 560 | 3.4 |
| H29TC-32 | 51 | 2 | -32 | 50.8 | 68.1 | 28.0 | 4050 | 112.0 | 16200 | 700 | 4.8 |

The combination of high temperature and high pressure could reduce the hose life.

ParLock Hose

Hose layline example

Parker TOUGH COVER H29TC-12 WP 43,0 MPa (6250 PSI) MSHA IC 40/26 | • EXCEED ISO3862 - EN856



Dab-19

Catalogue 4400/UK

High Pressure
Extreme abrasion resistance

ParLock Hose
H29ST

H29ST

ParLock Multispiral

Exceeds ISO 3862 Type 4SH – EN 856 Type 4SH



- Interlock technology
- Extreme abrasion resistant
SUPER TOUGH cover
- Reinforcement of four spiral high-tensile steel wire

Primary Applications

General high pressure hydraulic applications

Type Approvals

Details please find on pages **Ab-16** to **Ab-19**

Applicable Specifications

Exceed ISO 3862 Type 4SH – EN 856 Type 4SH

Construction

Inner tube: Synthetic rubber
Reinforcement: Four spiral high-tensile steel wire
Cover: Synthetic rubber
with a special polyethylene coating

Recommended Fluids

Hydraulic fluids on a mineral-oil basis, water-glycol and lubricating oils, air and water. For air and gas applications with a pressure exceeding 1.7 MPa, the cover must be pin-pricked. Consult the chemical compatibility section on pages **Ab-26** to **Ab-34** for more detailed information.

Temperature Range -40 °C up to +100 °C

Exception: Air max. +70 °C
Water max. +85 °C

Fitting Series

Internal and external skiving



| Part Number | Hose I.D. | | | | Hose O.D. mm | Pressure Rating | | | | min. bend radius mm | weight kg |
|-------------|-----------|-------|------|------|-----------------|------------------------------|------|----------------------------|-------|------------------------|--------------|
| | DN | Inch | Size | mm | | max. working pressure MPa | psi | min. burst pressure MPa | psi | | |
| H29ST-12 | 19 | 3/4 | -12 | 19.1 | 32.2 | 43.0 | 6250 | 172.0 | 25000 | 280 | 1.7 |
| H29ST-16 | 25 | 1 | -16 | 25.4 | 38.7 | 40.0 | 5800 | 160.0 | 23200 | 340 | 2.2 |
| H29ST-20 | 31 | 1 1/4 | -20 | 31.8 | 45.5 | 35.0 | 5000 | 140.0 | 20000 | 460 | 2.6 |
| H29ST-24 | 38 | 1 1/2 | -24 | 38.1 | 53.5 | 31.0 | 4500 | 124.0 | 18000 | 560 | 3.4 |
| H29ST-32 | 51 | 2 | -32 | 50.8 | 68.1 | 28.0 | 4050 | 112.0 | 16200 | 700 | 4.8 |

Replace the hose when any deformation or damage on the hose cover are visible.
The combination of high temperature and high pressure could reduce the hose life.

Hose layline example



Dab-20

Catalogue 4400/UK

H31

ParLock Multispiral

Exceeds ISO 3862 Type 4SP –
EN 856 Type 4SP



- Interlock technology
- Reinforcement of four spiral high-tensile steel wire

Primary Applications

General high pressure hydraulic applications

Type Approvals

Details please find on pages **Ab-16** to **Ab-19**

Applicable Specifications

Exceed ISO 3862 Type 4SP – EN 856 Type 4SP

Construction

Inner tube: Synthetic rubber
Reinforcement: Four spiral high-tensile steel wire
Cover: Synthetic rubber

Temperature Range -40 °C up to +100 °C

Exception: Air max. +70 °C
Water max. +85 °C

Recommended Fluids

Hydraulic fluids on a mineral-oil basis, water-glycol and lubricating oils, air and water. For air and gas applications with a pressure exceeding 1.7 MPa, the cover must be pin-pricked. Consult the chemical compatibility section on pages **Ab-26** to **Ab-34** for more detailed information.

Fitting Series

External skiving (size -4 up to -8)



Internal and external skiving (size -10 up to -16)



| Part Number | Hose I.D. | | | | Hose O.D. mm | Pressure Rating | | | | min. bend radius mm | weight kg |
|-------------|-----------|------|------|------|-----------------|------------------------------|------|----------------------------|-------|------------------------|--------------|
| | DN | Inch | Size | mm | | max. working pressure MPa | psi | min. burst pressure MPa | psi | | |
| H31-4 | 6 | 1/4 | -4 | 6.4 | 17.8 | 50.0 | 7250 | 200.0 | 29000 | 120 | 0.73 |
| H31-6 | 10 | 3/8 | -6 | 9.5 | 21.4 | 44.5 | 6450 | 178.0 | 25800 | 130 | 0.91 |
| H31-8 | 12 | 1/2 | -8 | 12.7 | 24.6 | 41.5 | 6000 | 166.0 | 24000 | 180 | 1.08 |
| H31-10 | 16 | 5/8 | -10 | 15.9 | 28.5 | 39.0 | 5650 | 156.0 | 22600 | 225 | 1.39 |
| H31-12 | 19 | 3/4 | -12 | 19.1 | 32.0 | 35.0 | 5000 | 140.0 | 20300 | 280 | 1.73 |
| H31-16 | 25 | 1 | -16 | 25.4 | 39.7 | 31.0 | 4500 | 124.0 | 18000 | 355 | 2.31 |

The combination of high temperature and high pressure could reduce the hose life.

ParLock Hose

Hose layline example

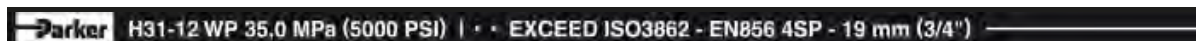

High Pressure
High abrasion resistance

ParLock Hose
H31TC

H31TC

ParLock Multispiral

Exceeds ISO 3862 Type 4SP – EN 856 Type 4SP

Primary Applications

General high pressure hydraulic applications

Type Approvals

Details please find on pages **Ab-16** to **Ab-19**

Applicable Specifications

Exceed ISO 3862 Type 4SP – EN 856 Type 4SP

Construction

Inner tube: Synthetic rubber
Reinforcement: Four spiral high-tensile steel wire
Cover: Highly abrasion resistance
MSHA approved synthetic rubber

Temperature Range -40 °C up to +100 °C

Exception: Air max. +70 °C
Water max. +85 °C



- Interlock technology
- Reinforcement of four spiral high-tensile steel wire
- Highly abrasion resistant **TOUGH COVER**
- MSHA approved
- Hose is suitable for temporary immersion in mineral oil up to 70 °C with frequent inspections

Recommended Fluids

Hydraulic fluids on a mineral-oil basis, water-glycol and lubricating oils, air and water. For air and gas applications with a pressure exceeding 1.7 MPa, the cover must be pin-pricked. Consult the chemical compatibility section on pages **Ab-26** to **Ab-34** for more detailed information.

Fitting Series

External skiving (size -4 up to -8)



Internal and external skiving (size -10 up to -16)



| Part Number | Hose I.D. | | | | Hose O.D. mm | Pressure Rating | | | | min. bend radius mm | weight kg |
|-------------|-----------|------|------|------|-----------------|------------------------------|------|----------------------------|-------|------------------------|--------------|
| | DN | Inch | Size | mm | | max. working pressure MPa | psi | min. burst pressure MPa | psi | | |
| H31TC-4 | 6 | 1/4 | -4 | 6.4 | 17.8 | 50.0 | 7250 | 200.0 | 29000 | 120 | 0.73 |
| H31TC-6 | 10 | 3/8 | -6 | 9.5 | 21.4 | 44.5 | 6450 | 178.0 | 25800 | 130 | 0.91 |
| H31TC-8 | 12 | 1/2 | -8 | 12.7 | 24.6 | 41.5 | 6000 | 166.0 | 24000 | 180 | 1.08 |
| H31TC-10 | 16 | 5/8 | -10 | 15.9 | 28.5 | 39.0 | 5650 | 156.0 | 22600 | 225 | 1.39 |
| H31TC-12 | 19 | 3/4 | -12 | 19.1 | 32.0 | 35.0 | 5000 | 140.0 | 20300 | 280 | 1.73 |
| H31TC-16 | 25 | 1 | -16 | 25.4 | 39.7 | 31.0 | 4500 | 124.0 | 18000 | 355 | 2.31 |

Replace the hose when any deformation or damage on the hose cover are visible.
The combination of high temperature and high pressure could reduce the hose life.

Hose layline example

Parker TOUGH COVER H31TC-6 WP 44,5 MPa (6450 PSI) MSHA IC 40/26 | • • EXCEED ISO3862 - EN856 4SP



Dab-22

Catalogue 4400/UK

High Pressure
Extreme abrasion resistance

ParLock Hose
H31ST

H31ST

ParLock Multispiral

Exceeds ISO 3862 Type 4SP – EN 856 Type 4SP



- Interlock technology
- Extreme abrasion resistant
SUPER TOUGH cover
- Reinforcement of four spiral high-tensile steel wire

Primary Applications

General high pressure hydraulic applications

Type Approvals

Details please find on pages **Ab-16** to **Ab-19**

Applicable Specifications

Exceed ISO 3862 Type 4SP – EN 856 Type 4SP

Construction

Inner tube: Synthetic rubber
Reinforcement: Four spiral high-tensile steel wire
Cover: Synthetic rubber with a special polyethylene coating

Temperature Range -40 °C up to +100 °C

Exception: Air max. +70 °C
Water max. +85 °C

Recommended Fluids

Hydraulic fluids on a mineral-oil basis, water-glycol and lubricating oils, air and water. For air and gas applications with a pressure exceeding 1.7 MPa, the cover must be pin-pricked. Consult the chemical compatibility section on pages **Ab-26** to **Ab-34** for more detailed information.

Fitting Series

External skiving (size -4 up to -8)



Internal and external skiving (size -10 up to -16)



| Part Number | Hose I.D. | | | | Hose O.D. mm | Pressure Rating | | | | min. bend radius mm | weight kg |
|-------------|-----------|------|------|------|-----------------|------------------------------|------|----------------------------|-------|------------------------|--------------|
| | DN | Inch | Size | mm | | max. working pressure MPa | psi | min. burst pressure MPa | psi | | |
| H31ST-4 | 6 | 1/4 | -4 | 6.4 | 17.8 | 50.0 | 7250 | 200.0 | 29000 | 120 | 0.73 |
| H31ST-6 | 10 | 3/8 | -6 | 9.5 | 21.4 | 44.5 | 6450 | 178.0 | 25800 | 130 | 0.91 |
| H31ST-8 | 12 | 1/2 | -8 | 12.7 | 24.6 | 41.5 | 6000 | 166.0 | 24000 | 180 | 1.08 |
| H31ST-10 | 16 | 5/8 | -10 | 15.9 | 28.5 | 39.0 | 5650 | 156.0 | 22600 | 225 | 1.39 |
| H31ST-12 | 19 | 3/4 | -12 | 19.1 | 32.0 | 35.0 | 5000 | 140.0 | 20300 | 280 | 1.73 |
| H31ST-16 | 25 | 1 | -16 | 25.4 | 39.7 | 31.0 | 4500 | 124.0 | 18000 | 355 | 2.31 |

The combination of high temperature and high pressure could reduce the hose life.

ParLock Hose

Hose layline example

Parker SUPER TOUGH H31ST-4 WP 50,0 MPa (7250 PSI) | · · EXCEED ISO3862 - EN856 4SP · ·



Dab-23

Catalogue 4400/UK

R35

ParLock Multispiral

Exceeds ISO 3862 Type R13 – Parker Specifications



- Interlock technology
- Reinforcement of four or six spiral high-tensile steel wire
- Constant working pressure of 35.0 MPa

Primary Applications

General high pressure hydraulic applications

Type Approvals

Details please find on pages **Ab-16** to **Ab-19**

Applicable Specifications

Exceed ISO 3862 Type R13 – Parker Specification

Construction

Inner tube: Synthetic rubber
Reinforcement: Four or six spiral high-tensile steel wire
Cover: Synthetic rubber

Temperature Range -40 °C up to +125 °C

Exception: Air max. +70 °C
Water max. +85 °C

Recommended Fluids

Hydraulic fluids on a mineral-oil basis, water-glycol and lubricating oils, air and water. For air and gas applications with a pressure exceeding 1.7 MPa, the cover must be pin-pricked. Consult the chemical compatibility section on pages **Ab-26** to **Ab-34** for more detailed information.

Fitting Series

Internal and external skiving (size -12, -16, -20)



Internal and external skiving (size -24, -32)



| Part Number | Hose I.D. | | | | Hose O.D. mm | Pressure Rating | | | | min. bend radius mm | weight kg |
|-------------|-----------|-------|------|------|-----------------|------------------------------|------|----------------------------|-------|------------------------|--------------|
| | DN | Inch | Size | mm | | max. working pressure MPa | psi | min. burst pressure MPa | psi | | |
| R35-12 | 19 | 3/4 | -12 | 19.1 | 32.00 | 35.0 | 5000 | 140.0 | 20000 | 220 | 1.5 |
| R35-16 | 25 | 1 | -16 | 25.4 | 39.35 | 35.0 | 5000 | 140.0 | 20000 | 280 | 2.2 |
| R35-20 | 31 | 1 1/4 | -20 | 31.8 | 45.50 | 35.0 | 5000 | 140.0 | 20000 | 380 | 2.6 |
| R35-24 | 38 | 1 1/2 | -24 | 38.1 | 57.30 | 35.0 | 5000 | 140.0 | 20000 | 480 | 4.8 |
| R35-32 | 51 | 2 | -32 | 50.8 | 71.10 | 35.0 | 5000 | 140.0 | 20000 | 600 | 6.7 |

The combination of high temperature and high pressure could reduce the hose life.

Hose layline example



High Pressure
High abrasion resistance

ParLock Hose
R35TC/RS35TC

R35TC/RS35TC-48

ParLock Multispiral

Exceeds ISO 3862 Type R13 – Parker Specifications

Primary Applications

General high pressure hydraulic applications

Type Approvals

Details please find on pages **Ab-16** to **Ab-19**

Applicable Specifications

Exceed ISO 3862 Type R13 – Parker Specification

Construction

Inner tube: Synthetic rubber
Reinforcement: Four or six spiral high-tensile steel wire
Cover: Highly abrasion resistance
MSHA approved synthetic rubber

Temperature Range -40 °C up to +125 °C

Exception: Air max. +70 °C
Water max. +85 °C

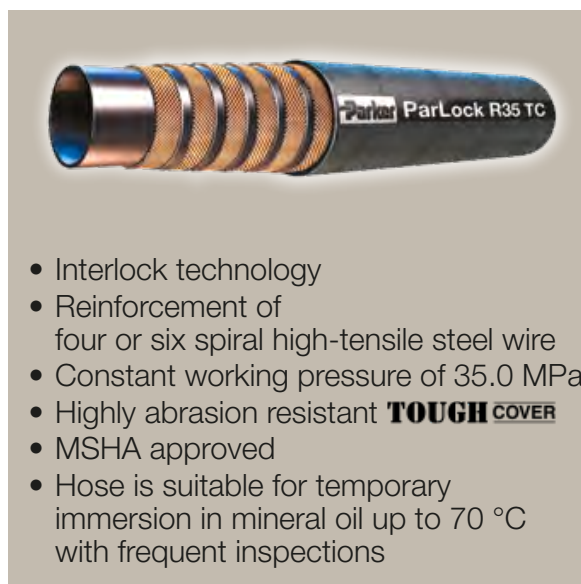

- Interlock technology
- Reinforcement of four or six spiral high-tensile steel wire
- Constant working pressure of 35.0 MPa
- Highly abrasion resistant **TOUGH COVER**
- MSHA approved
- Hose is suitable for temporary immersion in mineral oil up to 70 °C with frequent inspections

Recommended Fluids

Hydraulic fluids on a mineral-oil basis, water-glycol and lubricating oils, air and water. For air and gas applications with a pressure exceeding 1.7 MPa, the cover must be pin-pricked. Consult the chemical compatibility section on pages **Ab-26** to **Ab-34** for more detailed information.

Fitting Series

Internal and external skiving (size -12 up to -20) **V4**
Internal and external skiving (size -24 up to -48) **V6**

| Part Number | Hose I.D. | | | | Hose O.D. mm | Pressure Rating | | | | min. bend radius mm | weight kg |
|-------------|-----------|-------|------|------|-----------------|------------------------------|--------|----------------------------|-------|------------------------|--------------|
| | DN | Inch | Size | mm | | max. working pressure MPa | psi | min. burst pressure MPa | psi | | |
| R35TC-12 | 19 | 3/4 | -12 | 19.1 | 32.00 | 35.0 | 5000 | 140.0 | 20000 | 220 | 1.5 |
| R35TC-16 | 25 | 1 | -16 | 25.4 | 39.35 | 35.0 | 5000 | 140.0 | 20000 | 280 | 2.2 |
| R35TC-20 | 31 | 1 1/4 | -20 | 31.8 | 45.50 | 35.0 | 5000 | 140.0 | 20000 | 380 | 2.6 |
| R35TC-24 | 38 | 1 1/2 | -24 | 38.1 | 57.30 | 35.0 | 5000 | 140.0 | 20000 | 480 | 4.8 |
| R35TC-32 | 51 | 2 | -32 | 50.8 | 71.10 | 35.0 | 5000 | 140.0 | 20000 | 600 | 6.7 |
| R35TC-40 | 63 | 2 1/2 | -40 | 63.5 | 84.50 | 35.0 | 5000 | 140.0 | 20000 | 800 | 9.0 |
| RS35TC-48 | 76 | 3 | -48 | 76.2 | 96.00 | 35.0* | 5000* | 88.0 | 12750 | 900 | 10.0 |
| RS35TC-48 | 76 | 3 | -48 | 76.2 | 96.00 | 21.0** | 3040** | 88.0 | 12750 | 900 | 10.0 |

Replace the hose when any deformation or damage on the hose cover are visible. The combination of high temperature and high pressure could reduce the hose life.

* 35 MPa: Static applications according to ISO 6807-D

** 21 MPa: Dynamic hydraulic application design factor > 4:1

Hose layline example



Dab-25

Catalogue 4400/UK

ParLock Hose

R42

ParLock Multispiral

Exceeds ISO 3862 Type R15 – Parker Specifications



- Interlock technology
- Reinforcement of four or six spiral high-tensile steel wire
- Constant working pressure of 42.0 MPa

Primary Applications

General high pressure hydraulic applications

Type Approvals

Details please find on pages **Ab-16** to **Ab-19**

Applicable Specifications

Exceed ISO 3862 Type R15 – Parker Specification

Construction

Inner tube: Synthetic rubber
Reinforcement: Four or six spiral high-tensile steel wire
Cover: Synthetic rubber

Temperature Range -40 °C up to +125 °C

Exception: Air max. +70 °C
Water max. +85 °C

Recommended Fluids

Hydraulic fluids on a mineral-oil basis, water-glycol and lubricating oils, air and water. For air and gas applications with a pressure exceeding 1.7 MPa, the cover must be pin-pricked. Consult the chemical compatibility section on pages **Ab-26** to **Ab-34** for more detailed information.

Fitting Series

Internal and external skiving (size -10, -12, -16)



Internal and external skiving (size -20, -24, -32)



| Part Number | Hose I.D. | | | | Hose O.D. mm | Pressure Rating | | | | min. bend radius mm | weight kg |
|-------------|-----------|-------|------|------|-----------------|------------------------------|------|----------------------------|-------|------------------------|--------------|
| | DN | Inch | Size | mm | | max. working pressure MPa | psi | min. burst pressure MPa | psi | | |
| R42-10 | 16 | 5/8 | -10 | 15.9 | 28.50 | 42.0 | 6000 | 168.0 | 24000 | 225 | 1.39 |
| R42-12 | 19 | 3/4 | -12 | 19.1 | 32.00 | 42.0 | 6000 | 168.0 | 24000 | 280 | 1.70 |
| R42-16 | 25 | 1 | -16 | 25.4 | 39.00 | 42.0 | 6000 | 168.0 | 24000 | 300 | 2.30 |
| R42-20 | 31 | 1 1/4 | -20 | 31.8 | 50.75 | 42.0 | 6000 | 168.0 | 24000 | 400 | 3.80 |
| R42-24 | 38 | 1 1/2 | -24 | 38.1 | 57.00 | 42.0 | 6000 | 168.0 | 24000 | 500 | 4.80 |
| R42-32 | 51 | 2 | -32 | 50.8 | 71.50 | 42.0 | 6000 | 168.0 | 24000 | 700 | 7.00 |

The combination of high temperature and high pressure could reduce the hose life.

Hose layline example

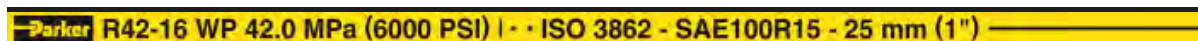

High Pressure
High abrasion resistance

ParLock Hose
R42TC

R42TC

ParLock Multispiral

Exceeds ISO 3862 Type R15 – Parker Specifications

Primary Applications

General high pressure hydraulic applications

Type Approvals

Details please find on pages **Ab-16** to **Ab-19**

Applicable Specifications

Exceed ISO 3862 Type R15 – Parker Specification

Construction

Inner tube: Synthetic rubber
Reinforcement: Four or six spiral high-tensile steel wire
Cover: Highly abrasion resistance
MSHA approved synthetic rubber

Temperature Range -40 °C up to +125 °C

Exception: Air max. +70 °C
Water max. +85 °C



- Interlock technology
- Reinforcement of four or six spiral high-tensile steel wire
- Constant working pressure of 42.0 MPa
- Highly abrasion resistant **TOUGH COVER**
- MSHA approved
- Hose is suitable for temporary immersion in mineral oil up to 70 °C with frequent inspections

Recommended Fluids

Hydraulic fluids on a mineral-oil basis, water-glycol and lubricating oils, air and water. For air and gas applications with a pressure exceeding 1.7 MPa, the cover must be pin-pricked. Consult the chemical compatibility section on pages **Ab-26** to **Ab-34** for more detailed information.

Fitting Series

Internal and external skiving (size -10, -12, -16)



Internal and external skiving (size -20, -24, -32)



| Part Number | Hose I.D. | | | | Hose O.D. mm | Pressure Rating | | | | min. bend radius mm | weight kg |
|-------------|-----------|-------|------|------|-----------------|------------------------------|------|----------------------------|-------|------------------------|--------------|
| | DN | Inch | Size | mm | | max. working pressure MPa | psi | min. burst pressure MPa | psi | | |
| R42TC-10 | 16 | 5/8 | -10 | 15.9 | 28.50 | 42.0 | 6000 | 168.0 | 24000 | 225 | 1.39 |
| R42TC-12 | 19 | 3/4 | -12 | 19.1 | 32.00 | 42.0 | 6000 | 168.0 | 24000 | 280 | 1.70 |
| R42TC-16 | 25 | 1 | -16 | 25.4 | 39.00 | 42.0 | 6000 | 168.0 | 24000 | 300 | 2.30 |
| R42TC-20 | 31 | 1 1/4 | -20 | 31.8 | 50.75 | 42.0 | 6000 | 168.0 | 24000 | 400 | 3.80 |
| R42TC-24 | 38 | 1 1/2 | -24 | 38.1 | 57.00 | 42.0 | 6000 | 168.0 | 24000 | 500 | 4.80 |
| R42TC-32 | 51 | 2 | -32 | 50.8 | 71.50 | 42.0 | 6000 | 168.0 | 24000 | 700 | 7.00 |

Replace the hose when any deformation or damage on the hose cover are visible.
The combination of high temperature and high pressure could reduce the hose life.

Hose layline example

Parker TOUGH COVER R42TC-32 WP 42.0 MPa (6000 PSI) MSHA IC 40/26 | · ISO 3862 - SAE100R



Dab-27

Catalogue 4400/UK

ParLock Hose

High Pressure
Extreme abrasion resistance

ParLock Hose
R42ST

R42ST

ParLock Multispiral

Exceeds ISO 3862 Type R15 – Parker Specifications



- Interlock technology
- Extreme abrasion resistant **SUPER TOUGH** cover
- Reinforcement of four or six spiral high-tensile steel wire
- Constant working pressure of 42.0 MPa

Primary Applications

General high pressure hydraulic applications

Type Approvals

Details please find on pages **Ab-16** to **Ab-19**

Applicable Specifications

Exceed ISO 3862 Type R15 – Parker Specification

Construction

Inner tube: Synthetic rubber
Reinforcement: Four or six spiral high-tensile steel wire
Cover: Synthetic rubber with a special polyethylene coating

Recommended Fluids

Hydraulic fluids on a mineral-oil basis, water-glycol and lubricating oils, air and water. For air and gas applications with a pressure exceeding 1.7 MPa, the cover must be pin-pricked. Consult the chemical compatibility section on pages **Ab-26** to **Ab-34** for more detailed information.

Temperature Range -40 °C up to +125 °C

Exception: Air max. +70 °C
Water max. +85 °C

Fitting Series

Internal and external skiving (size -10, -12, -16)



Internal and external skiving (size -20, -24, -32)



| Part Number | Hose I.D. | | | | Hose O.D. mm | Pressure Rating | | | | min. bend radius mm | weight kg |
|-------------|-----------|-------|------|------|-----------------|------------------------------|------|----------------------------|-------|------------------------|--------------|
| | DN | Inch | Size | mm | | max. working pressure MPa | psi | min. burst pressure MPa | psi | | |
| R42ST-10 | 16 | 5/8 | -10 | 15.9 | 28.50 | 42.0 | 6000 | 168.0 | 24000 | 225 | 1.39 |
| R42ST-12 | 19 | 3/4 | -12 | 19.1 | 32.00 | 42.0 | 6000 | 168.0 | 24000 | 280 | 1.70 |
| R42ST-16 | 25 | 1 | -16 | 25.4 | 39.00 | 42.0 | 6000 | 168.0 | 24000 | 300 | 2.30 |
| R42ST-20 | 31 | 1 1/4 | -20 | 31.8 | 50.75 | 42.0 | 6000 | 168.0 | 24000 | 400 | 3.80 |
| R42ST-24 | 38 | 1 1/2 | -24 | 38.1 | 57.00 | 42.0 | 6000 | 168.0 | 24000 | 500 | 4.80 |
| R42ST-32 | 51 | 2 | -32 | 50.8 | 71.50 | 42.0 | 6000 | 168.0 | 24000 | 700 | 7.00 |

The combination of high temperature and high pressure could reduce the hose life.

Hose layline example



Dab-28

Catalogue 4400/UK

High Pressure
High abrasion resistance

ParLock Hose
R50TC/R56TC

R50TC/R56TC

ParLock Multispiral

Exceeds ISO 3862 Type R15 – Parker Specifications

Primary Applications

Mobile hydraulic equipment and agricultural machines with typically large constructions.

Type Approvals

Details please find on pages **Ab-16** to **Ab-19**

Applicable Specifications

Exceed ISO 3862 Type R15 – Parker Specification

Construction

Inner tube: Synthetic rubber
Reinforcement: Four or six spiral high-tensile steel wire
Cover: Highly abrasion resistance
MSHA approved synthetic rubber

Temperature Range -40 °C up to +100 °C

Exception: Air max. +70 °C
Water max. +85 °C



- Interlock technology
- Reinforcement of four or six spiral high-tensile steel wire
- Constant working pressure of 50.0 MPa (R50TC) and 56.0 MPa (R56TC)
- Highly abrasion resistant **TOUGH COVER**
- MSHA approved
- Hose is suitable for temporary immersion in mineral oil up to 70 °C with frequent inspections

Recommended Fluids

Hydraulic fluids on a mineral-oil basis, water-glycol and lubricating oils, air and water. For air and gas applications with a pressure exceeding 1.7 MPa, the cover must be pin-pricked. Consult the chemical compatibility section on pages **Ab-26** to **Ab-34** for more detailed information.

Fitting Series Internal and external skiving

R56TC-4 up to R56TC-8

R50TC-10 up to -16

R50TC-20



| Part Number | Hose I.D. | | | | Hose O.D. mm | Pressure Rating | | | | min. bend radius mm | weight kg |
|-------------|-----------|-------|------|------|-----------------|------------------------------|------|----------------------------|-------|------------------------|--------------|
| | DN | Inch | Size | mm | | max. working pressure MPa | psi | min. burst pressure MPa | psi | | |
| R56TC-4 | 6 | 1/4 | -4 | 6.4 | 17.9 | 56.0 | 8100 | 224.0 | 32400 | 120 | 0.65 |
| R56TC-6 | 10 | 3/8 | -6 | 9.5 | 21.8 | 56.0 | 8100 | 224.0 | 32400 | 130 | 0.95 |
| R56TC-8 | 12 | 1/2 | -8 | 12.7 | 25.5 | 56.0 | 8100 | 224.0 | 32400 | 180 | 1.25 |
| R50TC-10 | 16 | 5/8 | -10 | 15.9 | 28.50 | 50.0 | 7250 | 200.0 | 29000 | 225 | 1.48 |
| R50TC-12 | 19 | 3/4 | -12 | 19.1 | 32.00 | 50.0 | 7250 | 200.0 | 29000 | 270 | 1.85 |
| R50TC-16 | 25 | 1 | -16 | 25.4 | 38.40 | 50.0 | 7250 | 200.0 | 29000 | 300 | 2.70 |
| R50TC-20 | 31 | 1 1/4 | -20 | 31.8 | 52.60 | 50.0 | 7250 | 200.0 | 29000 | 450 | 5.00 |

Replace the hose when any deformation or damage on the hose cover are visible.
The combination of high temperature and high pressure could reduce the hose life.

Hose layline example



Dab-29

Catalogue 4400/UK

ParLock Hose

BPK

Blastopak ParLock Multispiral DIN EN 1829-2



Primary Applications

Water blasting applications, water cutting applications, cleaning and paint or corrosion removal.
Not recommended for dynamic hydraulic applications

Applicable Specifications

Exceed ISO 3862 Type R15 – Parker Specification

Construction

Inner tube: Synthetic rubber
Reinforcement: Four or six spiral high-tensile steel wire
Cover: Synthetic rubber

Continuous Service Temperature Range

-10 °C up to +70 °C

Max. Service Temperature Range

-40 °C up to +93 °C



- Interlock technology
- Reinforcement of four or six spiral high-tensile steel wire
- DIN EN 1829-2
- Each hose assembly have to be proof tested at 1.5 WP with test report

Applicable Specifications

DIN EN 1829-2

Recommended Fluids

Water, water-soap emulsion

Fitting Series

Internal and external skiving



| Part Number | Hose I.D. | | | | Hose O.D. mm | Pressure Rating | | | | min. bend radius mm | weight kg |
|-------------|-----------|------|------|------|-----------------|------------------------------|-------|----------------------------|-------|------------------------|--------------|
| | DN | Inch | Size | mm | | max. working pressure MPa | psi | min. burst pressure MPa | psi | | |
| BPK-6 | 10 | 3/8 | -6 | 9.5 | 21.8 | 110.0 | 15900 | 275.0 | 39800 | 130 | 1.10 |
| BPK-8 | 12 | 1/2 | -8 | 12.7 | 25.5 | 110.0 | 15900 | 275.0 | 39800 | 200 | 1.40 |
| BPK-12 | 20 | 3/4 | -12 | 19.1 | 35.2 | 110.0 | 15900 | 275.0 | 39800 | 250 | 2.50 |
| BPK-16 | 25 | 1 | -16 | 25.4 | 41.8 | 80.0 | 11600 | 200.0 | 29000 | 300 | 3.00 |

Replace the hose when any deformation or damage on the hose cover are visible.
The combination of high temperature and high pressure could reduce the hose life.

Hose layline example



Dab-30

Catalogue 4400/UK

FA35

ParLock Multispiral Firearmor Blowout Preventer Application

Meets API 16D – Lloyd’s 1000/499 fire test

Primary Applications

Hydraulic system that operates the BOP security valve, both armored and without external protection. To be used on all rigs where fire resistance acc. to API 16D specifications are required.

Applicable Specifications

Meets API 16D – Lloyd’s 1000/499 fire test

Construction

Inner tube: Synthetic rubber
Reinforcement: Four or six spiral high-tensile steel wire
Cover: Special red flame resistant compound

Temperature Range -40 °C up to +100 °C

Exception: Air max. +70 °C
Water max. +85 °C



- Interlock Technology
- Fire armored as blowout preventer
- Special red flame resistant cover compound
- Constant working pressure of 35.0 MPa
- Design factor 4:1
- Very flexible
- Size -6 and -8 only to use with special sleeve FS-R-6 and FS-R-8
- Can be assembled only by Parker BOP certified distributors

Recommended Fluids

Hydraulic fluids on a mineral-oil basis, water-glycol and lubricating oils, air and water. For air and gas applications with a pressure exceeding 1.7 MPa, the cover must be pin-pricked. Consult the chemical compatibility section on pages **Ab-26** to **Ab-34** for more detailed information.

Fitting Series

External skiving (size -6 and -8)



Internal and external skiving (size -10 up to -20)



Internal and external skiving (size -24 and -32)



| Part Number | Hose I.D. | | | | Hose O.D. mm | Pressure Rating | | | | min. bend radius mm | weight kg |
|-------------|-----------|-------|------|------|-----------------|------------------------------|------|----------------------------|-------|------------------------|--------------|
| | DN | Inch | Size | mm | | max. working pressure MPa | psi | min. burst pressure MPa | psi | | |
| FA35-6 | 10 | 3/8 | -6 | 9.5 | 22.8 | 35.0 | 5000 | 140.0 | 20000 | 130 | 0.91 |
| FA35-8 | 12 | 1/2 | -8 | 12.7 | 25.2 | 35.0 | 5000 | 140.0 | 20000 | 180 | 1.08 |
| FA35-10 | 16 | 5/8 | -10 | 15.9 | 29.5 | 35.0 | 5000 | 140.0 | 20000 | 225 | 1.39 |
| FA35-12 | 19 | 3/4 | -12 | 19.1 | 32.4 | 35.0 | 5000 | 140.0 | 20000 | 280 | 1.70 |
| FA35-16 | 25 | 1 | -16 | 25.4 | 39.0 | 35.0 | 5000 | 140.0 | 20000 | 340 | 2.20 |
| FA35-20 | 31 | 1 1/4 | -20 | 31.8 | 46.6 | 35.0 | 5000 | 140.0 | 20000 | 460 | 2.60 |
| FA35-24 | 38 | 1 1/2 | -24 | 38.1 | 58.7 | 35.0 | 5000 | 140.0 | 20000 | 480 | 4.80 |
| FA35-32 | 51 | 2 | -32 | 50.8 | 72.0 | 35.0 | 5000 | 140.0 | 20000 | 600 | 6.70 |

Replace the hose when any deformation or damage on the hose cover are visible. The combination of high temperature and high pressure could reduce the hose life.

Parker BOP FS-R

is a red PKR rubber flame resistant sleeve that must be used for BOP hose assembly in order to protect the fitting area and be approved in accordance with the API 16D flame test.

The sleeve has to be fit over the fitting and doesn't need any clamp to be fixed.



Part Numbers: FS-R-6, FS-R-8

Hose layline example

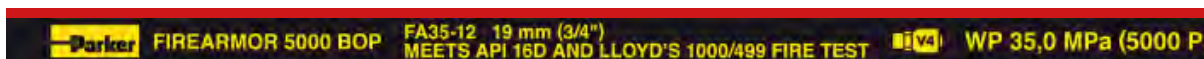

High Pressure
High abrasion resistance

ParLock Hose
RD35TC

RD35TC

ParLock Multispiral Drilling Application

API 7K Grade D/ISO 14693

Primary Applications

Rotary drilling and vibrator high pressure hydraulic applications

Type Approvals

Details please find on pages **Ab-16** to **Ab-19**

Applicable Specifications

API 7K Grade D/ISO 14693

Construction

Inner tube: Synthetic rubber
Reinforcement: Six spiral high-tensile steel wire
Cover: Highly abrasion resistance
MSHA approved synthetic rubber

Temperature Range -20 °C up to +100 °C

Exception: Air max. +70 °C
Water max. +85 °C



- Interlock Technology
- Reinforcement of six spiral high-tensile steel wire
- Constant working pressure of 35.0 MPa
- Design factor 2.5:1
- Highly abrasion resistant **TOUGH COVER**
- MSHA approved
- Hose is suitable for temporary immersion in mineral oil up to 70 °C with frequent inspections
- Antistatic properties

Recommended Fluids

Water, mud and cement, mineral oils, glycols and polyglycols, mineral oils in aqueous emulsion. Consult the chemical compatibility section on pages **Ab-26** to **Ab-34** for more detailed information.

Fitting Series

Internal and external skiving



| Part Number | Hose I.D. | | | | Hose O.D. mm | Pressure Rating | | | | min. bend radius mm | weight kg |
|-------------|-----------|------|------|------|-----------------|------------------------------|------|----------------------------|-------|------------------------|--------------|
| | DN | Inch | Size | mm | | max. working pressure MPa | psi | min. burst pressure MPa | psi | | |
| RD35TC-32 | 51 | 2 | -32 | 50.8 | 71.10 | 35.0 | 5000 | 88.0* | 12750 | 600 | 6.7 |

Replace the hose when any deformation or damage on the hose cover are visible. The combination of high temperature and high pressure could reduce the hose life.

Hose layline example

| | | | | | | | |
|--|-----------------------------|--|------------------|------------------------------------------------------------|------------------------------------|-----------------------------------|------------------------------------|
| | ROTARY DRILLING VIBRATOR | | RD35TC-48 | WP 34,5 MPa (5000 PSI) TEST PRESS. 69,0 MPa (10000 PSI) | ISO 14693 GRADE D MSHA IC 40/26 | -20°C TO +100°C -4°F TO +212°F | DN 76 mm (3") 1°° MADE IN ITALY |
|--|-----------------------------|--|------------------|------------------------------------------------------------|------------------------------------|-----------------------------------|------------------------------------|



Dab-32

Catalogue 4400/UK

CEM69TC

ParLock Multispiral Cementing Hose

According to API 7K

Primary Applications

Dedicated for cementing hose applications with flexible connection between the cementing pump manifold and cementing head for conveyance of cement slurries at high pressure.

Type Approvals

DNV-GL type examination certificate in accordance with API 7K.

Applicable Specifications

API 7K FSL0, ISO 14693

Construction

- Inner Tube: Synthetic rubber
- Reinforcement: Six spirals high-tensile steel wire
- Cover: Highly abrasion resistance
MSHA approved synthetic rubber

Temperature Range -20 °C up to +100 °C

- Exception: Air max. +70 °C
- Water max. +85 °C



- Interlock technology
- Reinforcement of six high tensile steel wire
- Design factor 1:2,25
- Highly abrasion resistant **TOUGH COVER**
- MSHA approved
- Antistatic properties

Recommended Fluids

Water and mud, mineral oils, glycols, polyglycol, mineral oils in aqueous emulsion and liquid cement.

Fitting Series

Internal and external skiving



| Part Number | Hose I.D. | | | | Hose O.D. mm | max. working pressure MPa | psi | Pressure Rating | | min. burst pressure MPa | psi | min. bend radius mm | weight kg |
|-------------|-----------|------|------|------|-----------------|------------------------------|-------|----------------------|-------|----------------------------|-------|------------------------|--------------|
| | DN | Inch | Size | mm | | | | test pressure MPa | psi | | | | |
| CEM69TC-32 | 51 | 2 | -32 | 50.8 | 71.5 | 69.0 | 10000 | 103.4 | 15000 | 155.3 | 22500 | 1000 | 7.00 |

Replace the hose when any deformation or damage on the hose cover are visible. The combination of high temperature and high pressure could reduce the hose life.

Parkrimp Hose

Hose layline example

| | | | | | | |
|--|----------------------------------------|------------|--------------------------------------------------------------|---------------------------------|--------------------------------------|-------------------------------------|
| | CEMENTING HOSE NOT FOR SOUR SERVICE | CEM69TC-32 | WP 69,0 MPA (10000 PSI) TEST PRESS. 103,4 MPA (15000 PSI) | API 7K - FSL 0 MSHA IC 40/26 | -20°C TO +100 °C -4 °F TO +212 °F | DN 51 mm (2") 100% MADE IN ITALY |
|--|----------------------------------------|------------|--------------------------------------------------------------|---------------------------------|--------------------------------------|-------------------------------------|









Dab-33

Catalogue 4400/UK

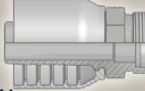



DIN – Metric

Page Db-1 – Db-4

| | | | |
|-------------------------------------------------------------------------------------------------------------------------------------------------------------------------------------------------------------------|--------------------------------------------------------------------------------------------------------------------------------------------------------------------------------------------------------------------------|-------------------------------------------------------------------------------------------------------------------------------------------------------------------------------------------------------------------------|---------------------------------------------------------------------------------------------------------------------------------------------------------------------------------------------------|
| <p>CA Db-1 Female Metric 24° Light Series with O-Ring Swivel – Straight ISO 12151-2-SWS-L – DKOL</p>  | <p>CE Db-1 Female Metric 24° Light Series with O-Ring Swivel – 45° Elbow ISO 12151-2-SWE-L – DKOL 45°</p>  | <p>CF Db-2 Female Metric 24° Light Series with O-Ring Swivel – 90° Elbow ISO 12151-2-SWE-L – DKOL 90°</p>  | <p>D0 Db-2 Male Metric 24° Light Series – Rigid Straight ISO 12151-2-S-L – CEL</p>  |
| <p>C9 Db-3 Female Metric 24° – Swivel Heavy Series with O-Ring Straight ISO 12151-2-SWS-S – DKOS</p>  | <p>OC Db-3 Female Metric 24° – Swivel Heavy Series with O-Ring 45° Elbow ISO 12151-2 – SWE-S – DKOS 45°</p>  | <p>1C Db-4 Female Metric 24° – Swivel Heavy Series with O-Ring 90° Elbow ISO 12151-2-SWE-S – DKOS 90°</p>  | <p>D2 Db-4 Male Metric 24° – Rigid Heavy Series – Straight ISO 12151-2-S-S – CES</p>  |

BSP

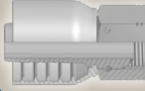
Page Db-5 – Db-7

| | | | |
|-------------------------------------------------------------------------------------------------------------------------------------------------------------------------------------------------------------------|------------------------------------------------------------------------------------------------------------------------------------------------------------------------------------------------------|-------------------------------------------------------------------------------------------------------------------------------------------------------------------------------------------------------|-------------------------------------------------------------------------------------------------------------------------------------------------------------------------------------------------|
| <p>92 Db-5 Female BSP Parallel Pipe Swivel – Straight (60° Cone) BS5200-A – DKR</p>  | <p>B1 Db-5 Female BSP Parallel Pipe Swivel 45° Elbow (60° Cone) BS 5200-D – DKR 45°</p>  | <p>B2 Db-6 Female BSP Parallel Pipe Swivel 90° Elbow (60° Cone) BS 5200-B – DKR 90°</p>  | <p>EA Db-6 BSP Swivel Female with O-Ring (60° Cone) BS 5200 – ISO 12151-6 – DKOR</p>  |
| <p>EC Db-7 BSP Swivel Female with O-Ring 90° Elbow (60° Cone) BS 5200 – ISO 12151-6 – DKOR 90°</p>  | <p>D9 Db-7 Male BSP Parallel Pipe Rigid – Straight (60° Cone) BS5200 – AGR</p>  | | |



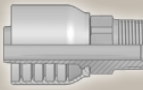
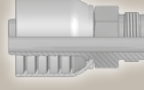
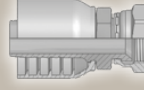
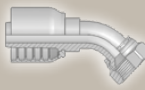
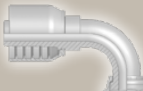

SAE

Page Db-8 – Db-10

| | | | |
|--------------------------------------------------------------------------------------------------------------------------------------------------------------------------------------------------------------------------|----------------------------------------------------------------------------------------------------------------------------------------------------------------------------|----------------------------------------------------------------------------------------------------------------------------------------------------------------------------------|----------------------------------------------------------------------------------------------------------------------------------------------------------------------------------------------|
| <p>01 Db-8 Male NPTF Pipe Rigid – Straight SAE J476A / J516 – AGN</p>  | <p>03 Db-8 Male JIC 37° – Rigid Straight ISO12151-5-S – AGJ</p>  | <p>06 Db-9 Female JIC 37° – Swivel Straight ISO12151-5-SWS – DKJ</p>  | <p>37 Db-10 Female JIC 37° – Swivel 45° Elbow ISO 12151-5-SWE 45° – DKJ 45°</p>  |
| <p>39/3W Db-10 Female JIC 37° SAE 45° – Dual Flare Swivel Female 90° Elbow ISO 12151-5-SWES – DKJ 90°</p>  | | | |

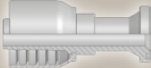
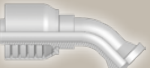

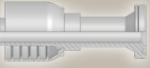
Flange

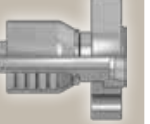
Page Db-11 – Db-14

| | | | |
|-------------------------------------------------------------------------------------------------------------------------------------------------------------------------------------------------------------------------------|------------------------------------------------------------------------------------------------------------------------------------------------------------------------------------------------------------------|-----------------------------------------------------------------------------------------------------------------------------------------------------------------------------------------------------------------|---------------------------------------------------------------------------------------------------------------------------------------------------------------------------------------------------------|
| <p>15 Db-11 ISO 6162-1-Flange Straight ISO 12151-3-S-L – SFL (21.0 MPa/ 3000 psi)</p>  | <p>17 Db-11 ISO 6162-1 Flange 45° Elbow ISO 12151-3 – E45 – L – SFL 45° (21.0 MPa/ 3000 psi)</p>  | <p>19 Db-12 ISO 6162-1-Flange 90° Elbow ISO 12151-3 – E – L – SFL 90° (21.0 MPa/ 3000 psi)</p>  | <p>6A Db-12 ISO 6162-2-Flange Straight ISO 12151-3-S-S – SFS (42.0 MPa/ 6000 psi)</p>  |
| <p>6F Db-13 ISO 6162-2-Flange 45° Elbow – Heavy Series ISO 12151-3 – E45-S – SFS 45° (42.0 MPa/ 6000 psi)</p>  | <p>6N Db-13 ISO 6162-2-Flange 90° Elbow ISO 12151-3 – E-S – SFS 90° (42.0 MPa/ 6000 psi)</p>  | <p>PY Db-14 Flange – 24° Male French Gas Straight</p>  | |

ORFS

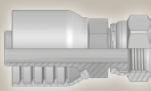
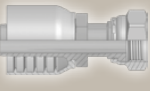
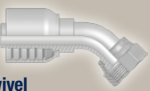
Page Db-15 – Db-17

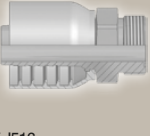
| | | | |
|-------------------------------------------------------------------------------------------------------------------------------------------------------------------------------------------------------------------|----------------------------------------------------------------------------------------------------------------------------------------------------------------------------------------|-------------------------------------------------------------------------------------------------------------------------------------------------------------------------------------------------------|------------------------------------------------------------------------------------------------------------------------------------------------------------------------------------------------------------------|
| <p>JC Db-15 Female ORFS Swivel – Straight Short ISO 12151-1 – SWSA SAE J516 – ORFS</p>  | <p>JS Db-15 ORFS Swivel Female (Long) ISO 12151-1-SWSB SAE J516 – ORFS</p>  | <p>J7 Db-16 Female ORFS – Swivel 45° Elbow ISO 12151-1 – SWE 45° SAE J516 – ORFS 45°</p>  | <p>J9 Db-16 Female ORFS – Swivel 90° Elbow – Short Drop ISO 12151-1 – SWES SAE J516 – ORFS 90°</p>  |
| <p>J1 Db-17 Female ORFS – Swivel 90° Elbow – Long Drop ISO 12151-1 – SWEL SAE J516 – ORFS 90° L</p>  | <p>JM Db-17 ORFS Male ISO 12151-1-S – SAE J516</p>  | | |

Others

Page Db-18

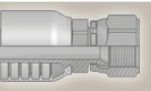
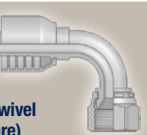
| | |
|-------------------------------------------------------------------------------------------------------------------------------------------------------------------------------------|--------------------------------------------------------------------------------------------------------------------------------------------------------------------------------------|
| <p>XU Db-18 Female Metric – Swivel Straight (30° Flare) JIS B8363</p>  | <p>XY Db-18 Female Metric – Swivel 90° Elbow (30° Flare) JIS B8363</p>  |
|-------------------------------------------------------------------------------------------------------------------------------------------------------------------------------------|--------------------------------------------------------------------------------------------------------------------------------------------------------------------------------------|

CA Female Metric 24° Light Series with O-Ring Swivel – Straight

ISO 12151-2-SWS-L – DKOL

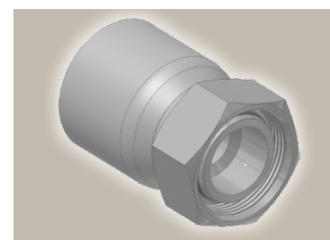
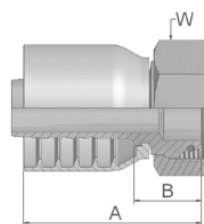

| Part Number | Hose I.D. | | | | Thread metric | Tube O.D. mm | A mm | B mm | W mm |
|-------------|-----------|------|------|------|------------------|--------------------|---------|---------|---------|
| | DN | Inch | Size | mm | | | | | |
| 1CA70-10-6 | 10 | 3/8 | -6 | 9.5 | M16x1.5 | 10 | 54 | 25 | 19 |
| 1CA70-12-6 | 10 | 3/8 | -6 | 9.5 | M18x1.5 | 12 | 54 | 24 | 22 |
| 1CA70-15-8 | 12 | 1/2 | -8 | 12.7 | M22x1.5 | 15 | 62 | 27 | 27 |
| 1CA70-18-8 | 12 | 1/2 | -8 | 12.7 | M26x1.5 | 18 | 57 | 22 | 32 |
| 1CA70-15-10 | 16 | 5/8 | -10 | 15.9 | M22x1.5 | 15 | 67 | 28 | 27 |
| 1CA70-18-10 | 16 | 5/8 | -10 | 15.9 | M26x1.5 | 18 | 62 | 25 | 32 |
| 1CA70-22-10 | 16 | 5/8 | -10 | 15.9 | M30x2 | 22 | 64 | 24 | 36 |
| 1CA70-18-12 | 19 | 3/4 | -12 | 19.1 | M26x1.5 | 18 | 65 | 26 | 32 |
| 1CA70-22-12 | 19 | 3/4 | -12 | 19.1 | M30x2 | 22 | 63 | 24 | 36 |
| 1CA70-28-12 | 19 | 3/4 | -12 | 19.1 | M36x2 | 28 | 66 | 26 | 41 |
| 1CA70-28-16 | 25 | 1 | -16 | 25.4 | M36x2 | 28 | 78 | 33 | 41 |
| 1CA70-35-16 | 25 | 1 | -16 | 25.4 | M45x2 | 35 | 76 | 31 | 50 |

Fittings with standard O-ring seals can be used for temperatures from -40 °C up to +105 °C.
O-rings see section Eb. Special O-rings are available on request.

CE Female Metric 24° Light Series with O-Ring Swivel – 45° Elbow

ISO 12151-2-SWE -L – DKOL 45°

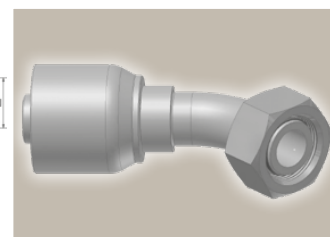
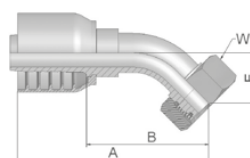

| Part Number | Hose I.D. | | | | Thread metric | Tube O.D. mm | A mm | B mm | E mm | W mm |
|-------------|-----------|------|------|------|------------------|--------------------|---------|---------|---------|---------|
| | DN | Inch | Size | mm | | | | | | |
| 1CE70-12-6 | 10 | 3/8 | -6 | 9.5 | M18x1.5 | 12 | 70 | 40 | 20 | 22 |
| 1CE70-15-8 | 12 | 1/2 | -8 | 12.7 | M22x1.5 | 15 | 85 | 50 | 24 | 27 |
| 1CE70-18-10 | 16 | 5/8 | -10 | 15.9 | M26x1.5 | 18 | 89 | 49 | 23 | 32 |
| 1CE70-22-12 | 19 | 3/4 | -12 | 19.1 | M30x2 | 22 | 98 | 58 | 26 | 36 |
| 1CE70-28-16 | 25 | 1 | -16 | 25.4 | M36x2 | 28 | 127 | 80 | 34 | 41 |

Fittings with standard O-ring seals can be used for temperatures from -40 °C up to +105 °C.
O-rings see section Eb. Special O-rings are available on request.

70 Series

Approved **fitting series** for hose types, depending on size:

70 371LT 372 372RH 372TC 701 701 TC F42-8



CF **Female Metric 24°
Light Series with O-Ring
Swivel – 90° Elbow**
ISO 12151-2-SWE-L – DKOL 90°

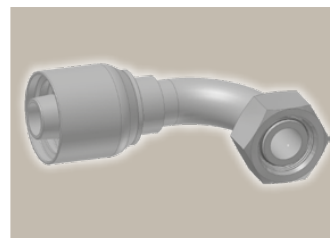
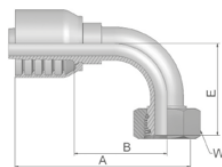

| Part Number | Hose I.D. | | | | Thread metric | Tube O.D. mm | A mm | B mm | E mm | W mm |
|-------------|-----------|------|------|------|------------------|--------------------|---------|---------|---------|---------|
| | DN | Inch | Size | mm | | | | | | |
| 1CF70-10-6 | 10 | 3/8 | -6 | 9.5 | M16x1.5 | 10 | 67 | 38 | 39 | 19 |
| 1CF70-12-6 | 10 | 3/8 | -6 | 9.5 | M18x1.5 | 12 | 67 | 38 | 37 | 22 |
| 1CF70-15-8 | 12 | 1/2 | -8 | 12.7 | M22x1.5 | 15 | 73 | 39 | 45 | 27 |
| 1CF70-18-8 | 12 | 1/2 | -8 | 12.7 | M26x1.5 | 18 | 71 | 36 | 40 | 32 |
| 1CF70-15-10 | 16 | 5/8 | -10 | 15.9 | M22x1.5 | 15 | 79 | 42 | 51 | 27 |
| 1CF70-18-10 | 16 | 5/8 | -10 | 15.9 | M26x1.5 | 18 | 79 | 42 | 49 | 32 |
| 1CF70-18-12 | 19 | 3/4 | -12 | 19.1 | M26x1.5 | 18 | 89 | 49 | 56 | 32 |
| 1CF70-22-12 | 19 | 3/4 | -12 | 19.1 | M30x2 | 22 | 89 | 49 | 55 | 36 |
| 1CF70-28-16 | 25 | 1 | -16 | 25.4 | M36x2 | 28 | 114 | 68 | 78 | 41 |
| 1CF70-35-16 | 25 | 1 | -16 | 25.4 | M45x2 | 35 | 115 | 68 | 69 | 50 |

Fittings with standard O-ring seals can be used for temperatures from -40 °C up to +105 °C.
O-rings see section Eb. Special O-rings are available on request.

D0 **Male Metric 24°
Light Series – Rigid
Straight**
ISO 12151-2-S-L – CEL

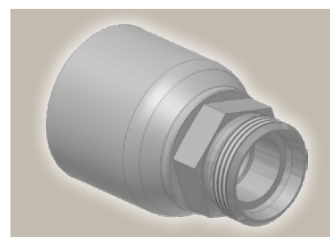
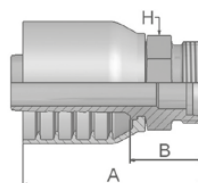

| Part Number | Hose I.D. | | | | Thread metric | Tube O.D. mm | A mm | B mm | H mm |
|-------------|-----------|------|------|------|------------------|--------------------|---------|---------|---------|
| | DN | Inch | Size | mm | | | | | |
| 1D070-15-8 | 12 | 1/2 | -8 | 12.7 | M22x1.5 | 15 | 60 | 26 | 22 |
| 1D070-18-10 | 16 | 5/8 | -10 | 15.9 | M26x1.5 | 18 | 65 | 28 | 27 |
| 1D070-22-12 | 19 | 3/4 | -12 | 19.1 | M30x2 | 22 | 69 | 30 | 30 |
| 1D070-28-16 | 25 | 1 | -16 | 25.4 | M36x2 | 28 | 79 | 32 | 36 |

Approved **fitting series** for hose types, depending on size:

70 371LT 372 372RH 372TC 701 701 TC F42-8



C9 Female Metric 24° – Swivel Heavy Series with O-Ring Straight

ISO 12151-2-SWS-S – DKOS

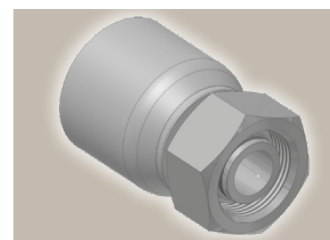
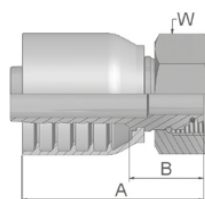

| Part Number | Hose I.D. | | | | Thread metric | Tube O.D. mm | A mm | B mm | W mm |
|-------------|-----------|------|------|------|---------------|--------------|------|------|------|
| | DN | Inch | Size | mm | | | | | |
| 1C970-8-6 | 10 | 3/8 | -6 | 9.5 | M16x1.5 | 8 | 53 | 24 | 19 |
| 1C970-12-6 | 10 | 3/8 | -6 | 9.5 | M20x1.5 | 12 | 52 | 22 | 24 |
| 1C970-14-6 | 10 | 3/8 | -6 | 9.5 | M22x1.5 | 14 | 53 | 24 | 27 |
| 1C970-12-8 | 12 | 1/2 | -8 | 12.7 | M20x1.5 | 12 | 60 | 25 | 24 |
| 1C970-16-8 | 12 | 1/2 | -8 | 12.7 | M24x1.5 | 16 | 59 | 24 | 30 |
| 1C970-20-8 | 12 | 1/2 | -8 | 12.7 | M30x2 | 20 | 59 | 24 | 36 |
| 1C970-16-10 | 16 | 5/8 | -10 | 15.9 | M24x1.5 | 16 | 66 | 27 | 30 |
| 1C970-20-10 | 16 | 5/8 | -10 | 15.9 | M30x2 | 20 | 64 | 27 | 36 |
| 1C970-25-10 | 16 | 5/8 | -10 | 15.9 | M36x2 | 25 | 65 | 29 | 46 |
| 1C970-20-12 | 19 | 3/4 | -12 | 19.1 | M30x2 | 20 | 66 | 27 | 36 |
| 1C970-25-12 | 19 | 3/4 | -12 | 19.1 | M36x2 | 25 | 68 | 28 | 46 |
| 1C970-25-16 | 25 | 1 | -16 | 25.4 | M36x2 | 25 | 78 | 33 | 46 |
| 1C970-30-16 | 25 | 1 | -16 | 25.4 | M42x2 | 30 | 80 | 33 | 50 |

Fittings with standard O-ring seals can be used for temperatures from -40 °C up to +105 °C.
O-rings see section Eb. Special O-rings are available on request.

OC Female Metric 24° – Swivel Heavy Series with O-Ring 45° Elbow

ISO 12151-2 – SWE -S – DKOS 45°

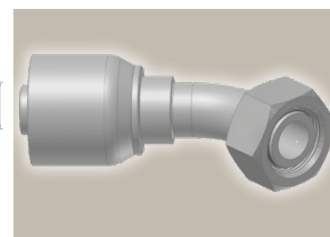
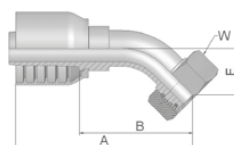

| Part Number | Hose I.D. | | | | Thread metric | Tube O.D. mm | A mm | B mm | E mm | W mm |
|-------------|-----------|------|------|------|---------------|--------------|------|------|------|------|
| | DN | Inch | Size | mm | | | | | | |
| 10C70-12-6 | 10 | 3/8 | -6 | 9.5 | M20x1.5 | 12 | 69 | 40 | 20 | 24 |
| 10C70-14-6 | 10 | 3/8 | -6 | 9.5 | M22x1.5 | 14 | 76 | 46 | 20 | 27 |
| 10C70-16-8 | 12 | 1/2 | -8 | 12.7 | M24x1.5 | 16 | 83 | 48 | 24 | 30 |
| 10C70-16-10 | 16 | 5/8 | -10 | 15.9 | M24x1.5 | 16 | 88 | 49 | 22 | 30 |
| 10C70-20-10 | 16 | 5/8 | -10 | 15.9 | M30x2 | 20 | 91 | 51 | 25 | 36 |
| 10C70-25-10 | 16 | 5/8 | -10 | 15.9 | M36x2 | 25 | 92 | 56 | 27 | 46 |
| 10C70-20-12 | 19 | 3/4 | -12 | 19.1 | M30x2 | 20 | 99 | 60 | 28 | 36 |
| 10C70-25-12 | 19 | 3/4 | -12 | 19.1 | M36x2 | 25 | 100 | 61 | 29 | 46 |
| 10C70-25-16 | 25 | 1 | -16 | 25.4 | M36x2 | 25 | 123 | 76 | 33 | 46 |
| 10C70-30-16 | 25 | 1 | -16 | 25.4 | M42x2 | 30 | 126 | 79 | 36 | 50 |

Fittings with standard O-ring seals can be used for temperatures from -40 °C up to +105 °C.
O-rings see section Eb. Special O-rings are available on request.

Approved **fitting series** for hose types, depending on size:

70 371LT 372 372RH 372TC 701 701 TC F42-8



1C Female Metric 24° – Swivel Heavy Series with O-Ring 90° Elbow

ISO 12151-2-SWE-S – DKOS 90°

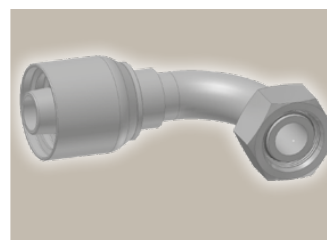
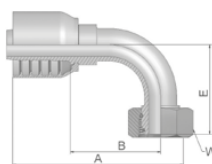

| Part Number | Hose I.D. | | | | Thread metric | Tube O.D. mm | A mm | B mm | E mm | W mm |
|-------------|-----------|------|------|------|------------------|--------------------|---------|---------|---------|---------|
| | DN | Inch | Size | mm | | | | | | |
| 11C70-8-6 | 10 | 3/8 | -6 | 9.5 | M16x1.5 | 8 | 67 | 38 | 37 | 19 |
| 11C70-12-6 | 10 | 3/8 | -6 | 9.5 | M20x1.5 | 12 | 67 | 38 | 37 | 24 |
| 11C70-14-6 | 10 | 3/8 | -6 | 9.5 | M22x1.5 | 14 | 64 | 35 | 37 | 27 |
| 11C70-16-8 | 12 | 1/2 | -8 | 12.7 | M24x1.5 | 16 | 72 | 37 | 45 | 30 |
| 11C70-20-8 | 12 | 1/2 | -8 | 12.7 | M30x2 | 20 | 75 | 40 | 46 | 36 |
| 11C70-16-10 | 16 | 5/8 | -10 | 15.9 | M24x1.5 | 16 | 79 | 40 | 45 | 30 |
| 11C70-20-10 | 16 | 5/8 | -10 | 15.9 | M30x2 | 20 | 79 | 40 | 48 | 36 |
| 11C70-25-10 | 16 | 5/8 | -10 | 15.9 | M36x2 | 25 | 85 | 45 | 52 | 46 |
| 11C70-20-12 | 19 | 3/4 | -12 | 19.1 | M30x2 | 20 | 89 | 50 | 58 | 36 |
| 11C70-25-12 | 19 | 3/4 | -12 | 19.1 | M36x2 | 25 | 89 | 49 | 59 | 46 |
| 11C70-30-12 | 19 | 3/4 | -12 | 19.1 | M42x2 | 30 | 89 | 50 | 60 | 50 |
| 11C70-25-16 | 25 | 1 | -16 | 25.4 | M36x2 | 25 | 109 | 64 | 69 | 46 |
| 11C70-30-16 | 25 | 1 | -16 | 25.4 | M42x2 | 30 | 115 | 68 | 76 | 50 |

Fittings with standard O-ring seals can be used for temperatures from -40 °C up to +105 °C.
O-rings see section Eb. Special O-rings are available on request.

D2 Male Metric 24° – Rigid Heavy Series – Straight

ISO 12151-2-S-S – CES

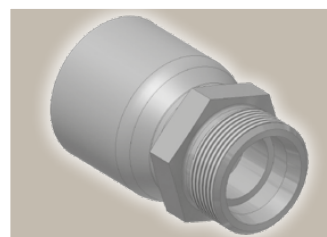
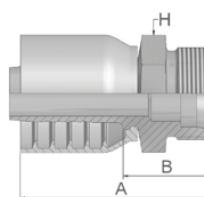

| Part Number | Hose I.D. | | | | Thread metric | Tube O.D. mm | A mm | B mm | H mm |
|-------------|-----------|------|------|------|------------------|--------------------|---------|---------|---------|
| | DN | Inch | Size | mm | | | | | |
| 1D270-12-6 | 10 | 3/8 | -6 | 9.5 | M20x1.5 | 12 | 53 | 24 | 22 |
| 1D270-14-6 | 10 | 3/8 | -6 | 9.5 | M22x1.5 | 14 | 55 | 25 | 22 |
| 1D270-16-8 | 12 | 1/2 | -8 | 12.7 | M24x1.5 | 16 | 62 | 28 | 24 |
| 1D270-20-8 | 12 | 1/2 | -8 | 12.7 | M30x2 | 20 | 67 | 32 | 30 |
| 1D270-20-10 | 16 | 5/8 | -10 | 15.9 | M30x2 | 20 | 75 | 32 | 30 |
| 1D270-20-12 | 19 | 3/4 | -12 | 19.1 | M30x2 | 20 | 72 | 33 | 30 |
| 1D270-25-12 | 19 | 3/4 | -12 | 19.1 | M36x2 | 25 | 74 | 35 | 36 |
| 1D270-25-16 | 25 | 1 | -16 | 25.4 | M36x2 | 25 | 84 | 37 | 36 |
| 1D270-30-16 | 25 | 1 | -16 | 25.4 | M42x2 | 30 | 85 | 40 | 46 |

Approved **fitting series** for hose types, depending on size:

70 371LT 372 372RH 372TC 701 701 TC F42-8

92 Female BSP Parallel Pipe Swivel – Straight (60° Cone)

BS5200-A – DKR

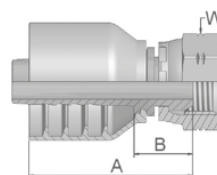

| Part Number | Hose I.D. | | | | Thread BSP | A mm | B mm | W mm |
|-------------|-----------|------|------|------|---------------|---------|---------|---------|
| | DN | Inch | Size | mm | | | | |
| 19270-6-6 | 10 | 3/8 | -6 | 9.5 | 3/8x19 | 49 | 20 | 22 |
| 19270-8-6 | 10 | 3/8 | -6 | 9.5 | 1/2x14 | 51 | 22 | 27 |
| 19270-8-8 | 12 | 1/2 | -8 | 12.7 | 1/2x14 | 57 | 22 | 27 |
| 19270-10-8 | 12 | 1/2 | -8 | 12.7 | 5/8x14 | 55 | 20 | 30 |
| 19270-10-10 | 16 | 5/8 | -10 | 15.9 | 5/8x14 | 57 | 21 | 30 |
| 19270-12-10 | 16 | 5/8 | -10 | 15.9 | 3/4x14 | 61 | 22 | 32 |
| 19270-12-12 | 19 | 3/4 | -12 | 19.1 | 3/4x14 | 61 | 22 | 32 |
| 19270-16-12 | 19 | 3/4 | -12 | 19.1 | 1x11 | 63 | 24 | 41 |
| 19270-16-16 | 25 | 1 | -16 | 25.4 | 1x11 | 72 | 25 | 41 |

B1 Female BSP Parallel Pipe Swivel 45° Elbow (60° Cone)

BS 5200-D – DKR 45°

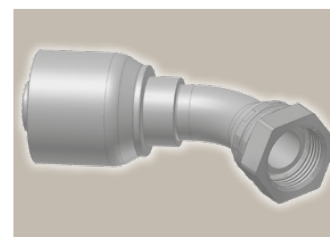
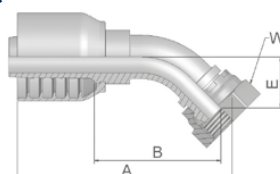

| Part Number | Hose I.D. | | | | Thread BSP | A mm | B mm | E mm | W mm |
|-------------|-----------|------|------|------|---------------|---------|---------|---------|---------|
| | DN | Inch | Size | mm | | | | | |
| 1B170-4-6 | 10 | 3/8 | -6 | 9.5 | 1/4x19 | 68 | 39 | 19 | 19 |
| 1B170-6-6 | 10 | 3/8 | -6 | 9.5 | 3/8x19 | 67 | 37 | 17 | 22 |
| 1B170-8-6 | 10 | 3/8 | -6 | 9.5 | 1/2x14 | 68 | 39 | 19 | 27 |
| 1B170-8-8 | 12 | 1/2 | -8 | 12.7 | 1/2x14 | 79 | 45 | 20 | 27 |
| 1B170-10-8 | 12 | 1/2 | -8 | 12.7 | 5/8x14 | 78 | 43 | 19 | 30 |
| 1B170-10-10 | 16 | 5/8 | -10 | 15.9 | 5/8x14 | 89 | 50 | 23 | 30 |
| 1B170-12-10 | 16 | 5/8 | -10 | 15.9 | 3/4x14 | 88 | 49 | 22 | 32 |
| 1B170-12-12 | 19 | 3/4 | -12 | 19.1 | 3/4x14 | 96 | 57 | 25 | 32 |
| 1B170-16-12 | 19 | 3/4 | -12 | 19.1 | 1x11 | 95 | 56 | 24 | 41 |
| 1B170-16-16 | 25 | 1 | -16 | 25.4 | 1x11 | 121 | 77 | 33 | 41 |

70 Series

Approved **fitting series** for hose types, depending on size:

70 371LT 372 372RH 372TC 701 701 TC F42-8

B2 Female BSP Parallel Pipe Swivel 90° Elbow (60° Cone)

BS 5200-B – DKR 90°

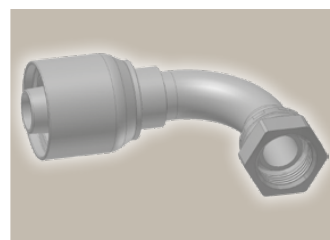
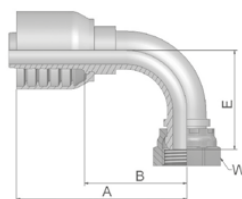

| Part Number | Hose I.D. | | | | Thread BSP | A mm | B mm | E mm | W mm |
|-------------|-----------|------|------|------|---------------|---------|---------|---------|---------|
| | DN | Inch | Size | mm | | | | | |
| 1B270-6-6 | 10 | 3/8 | -6 | 9.5 | 3/8x19 | 66 | 37 | 33 | 22 |
| 1B270-8-6 | 10 | 3/8 | -6 | 9.5 | 1/2x14 | 66 | 37 | 35 | 27 |
| 1B270-8-8 | 12 | 1/2 | -8 | 12.7 | 1/2x14 | 70 | 35 | 39 | 27 |
| 1B270-10-8 | 12 | 1/2 | -8 | 12.7 | 5/8x14 | 74 | 39 | 38 | 30 |
| 1B270-10-10 | 16 | 5/8 | -10 | 15.9 | 5/8x14 | 81 | 41 | 46 | 30 |
| 1B270-12-10 | 16 | 5/8 | -10 | 15.9 | 3/4x14 | 92 | 52 | 59 | 32 |
| 1B270-16-10 | 16 | 5/8 | -10 | 15.9 | 1x11 | 86 | 46 | 44 | 41 |
| 1B270-12-12 | 19 | 3/4 | -12 | 19.1 | 3/4x14 | 89 | 50 | 53 | 32 |
| 1B270-16-12 | 19 | 3/4 | -12 | 19.1 | 1x11 | 89 | 49 | 51 | 41 |
| 1B270-16-16 | 25 | 1 | -16 | 25.4 | 1x11 | 116 | 69 | 69 | 41 |

EA BSP Swivel Female with O-Ring (60° Cone)

BS 5200 – ISO 12151-6 – DKOR

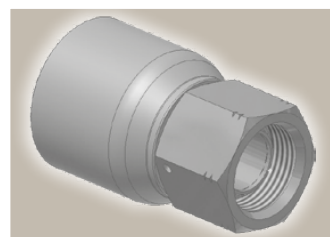
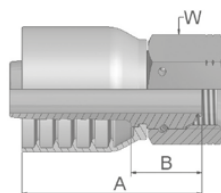

| Part Number | Hose I.D. | | | | Thread BSP | A mm | B mm | W mm |
|-------------|-----------|------|------|------|---------------|---------|---------|---------|
| | DN | Inch | Size | mm | | | | |
| 1EA70-8-8 | 12 | 1/2 | -8 | 12.7 | 1/2x14 | 56 | 21 | 27 |
| 1EA70-12-12 | 19 | 3/4 | -12 | 19.1 | 3/4x14 | 63 | 23 | 32 |
| 1EA70-16-16 | 25 | 1 | -16 | 25.4 | 1x11 | 77 | 31 | 41 |

Fittings with standard O-ring seals can be used for temperatures from -40 °C up to +105 °C.
O-rings see section Eb. Special O-rings are available on request.

Approved **fitting series** for hose types, depending on size:

70 371LT 372 372RH 372TC 701 701 TC F42-8



EC **BSP Swivel Female
with O-Ring
90° Elbow (60° Cone)**

BS 5200 – ISO 12151-6 – DKOR 90°

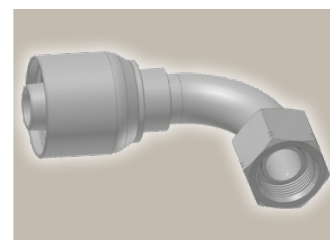
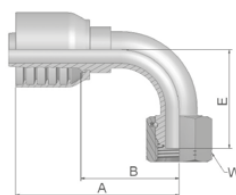

| Part Number | Hose I.D. | | | | Thread BSP | A mm | B mm | E mm | W mm |
|-------------|-----------|------|------|------|---------------|---------|---------|---------|---------|
| | DN | Inch | Size | mm | | | | | |
| 1EC70-8-8 | 12 | 1/2 | -8 | 12.7 | 1/2x14 | 71 | 36 | 40 | 27 |
| 1EC70-12-12 | 19 | 3/4 | -12 | 19.1 | 3/4x14 | 89 | 49 | 55 | 32 |
| 1EC70-16-16 | 25 | 1 | -16 | 25.4 | 1x11 | 115 | 68 | 71 | 41 |

Fittings with standard O-ring seals can be used for temperatures from -40 °C up to +105 °C.
O-rings see section Eb. Special O-rings are available on request.

D9 **Male BSP Parallel Pipe
Rigid – Straight (60° Cone)**

BS5200 – AGR

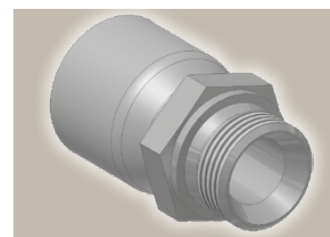
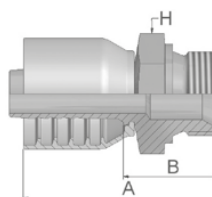

| Part Number | Hose I.D. | | | | Thread BSP | A mm | B mm | H mm |
|-------------|-----------|------|------|------|---------------|---------|---------|---------|
| | DN | Inch | Size | mm | | | | |
| 1D970-6-6 | 10 | 3/8 | -6 | 9.5 | 3/8x19 | 57 | 28 | 22 |
| 1D970-8-6 | 10 | 3/8 | -6 | 9.5 | 1/2x14 | 60 | 31 | 27 |
| 1D970-8-8 | 12 | 1/2 | -8 | 12.7 | 1/2x14 | 62 | 28 | 27 |
| 1D970-10-8 | 12 | 1/2 | -8 | 12.7 | 5/8x14 | 70 | 36 | 30 |
| 1D970-12-8 | 12 | 1/2 | -8 | 12.7 | 3/4x14 | 69 | 35 | 32 |
| 1D970-10-10 | 16 | 5/8 | -10 | 15.9 | 5/8x14 | 75 | 36 | 30 |
| 1D970-12-10 | 16 | 5/8 | -10 | 15.9 | 3/4x14 | 72 | 35 | 32 |
| 1D970-12-12 | 19 | 3/4 | -12 | 19.1 | 3/4x14 | 72 | 33 | 32 |
| 1D970-16-12 | 19 | 3/4 | -12 | 19.1 | 1x11 | 77 | 38 | 41 |
| 1D970-16-16 | 25 | 1 | -16 | 25.4 | 1x11 | 85 | 40 | 41 |

70 Series

Approved **fitting series** for hose types, depending on size:

| | | | | | | | |
|-----------|-------|-----|-------|-------|-----|--------|-------|
| 70 | 371LT | 372 | 372RH | 372TC | 701 | 701 TC | F42-8 |
|-----------|-------|-----|-------|-------|-----|--------|-------|



Db-7

Catalogue 4400/UK

01 Male NPTF Pipe Rigid – Straight

SAE J476A/ J516 – AGN

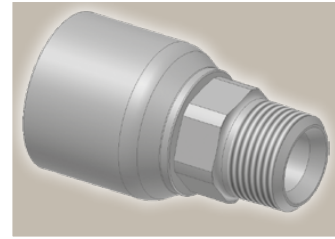
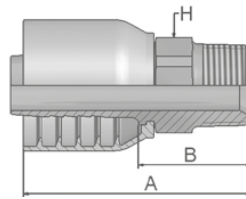

| Part Number | Hose I.D. | | | | Thread NPTF | A mm | B mm | H mm |
|----------------|-----------|------|------|------|----------------|---------|---------|---------|
| | DN | Inch | Size | mm | | | | |
| 10170-6-6-SM | 10 | 3/8 | -6 | 9.5 | 3/8-18 | 60 | 31 | 19 |
| 10170-12-8-SM | 12 | 1/2 | -8 | 12.7 | 3/4-14 | 68 | 33 | 27 |
| 10170-8-10-SM | 16 | 5/8 | -10 | 15.9 | 1/2-14 | 75 | 38 | 24 |
| 10170-12-10-SM | 16 | 5/8 | -10 | 15.9 | 3/4-14 | 71 | 34 | 27 |
| 10170-12-12-SM | 19 | 3/4 | -12 | 19.1 | 3/4-14 | 79 | 39 | 27 |
| 10170-16-12-SM | 19 | 3/4 | -12 | 19.1 | 1-11 1/2 | 79 | 39 | 36 |

03 Male JIC 37° – Rigid Straight

ISO12151-5-S – AGJ

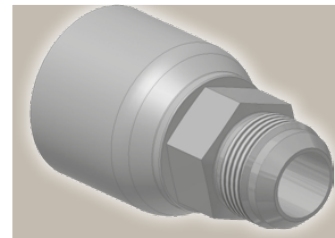
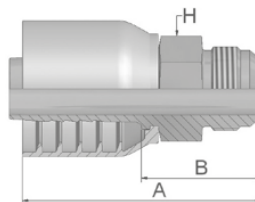

| Part Number | Hose I.D. | | | | Thread UNF | A mm | B mm | H mm |
|----------------|-----------|------|------|------|---------------|---------|---------|---------|
| | DN | Inch | Size | mm | | | | |
| 10370-6-6-SM | 10 | 3/8 | -6 | 9.5 | 9/16x18 | 60 | 31 | 19 |
| 10370-8-6-SM | 10 | 3/8 | -6 | 9.5 | 3/4x16 | 59 | 29 | 19 |
| 10370-8-8-SM | 12 | 1/2 | -8 | 12.7 | 3/4x16 | 68 | 33 | 22 |
| 10370-10-8-SM | 12 | 1/2 | -8 | 12.7 | 7/8x14 | 68 | 34 | 24 |
| 10370-12-8-SM | 12 | 1/2 | -8 | 12.7 | 1 1/16x12 | 71 | 36 | 27 |
| 10370-10-10-SM | 16 | 5/8 | -10 | 15.9 | 7/8x14 | 75 | 38 | 24 |
| 10370-12-10-SM | 16 | 5/8 | -10 | 15.9 | 1 1/16x12 | 78 | 39 | 27 |
| 10370-12-12-SM | 19 | 3/4 | -12 | 19.1 | 1 1/16x12 | 82 | 42 | 27 |
| 10370-16-12-SM | 19 | 3/4 | -12 | 19.1 | 1 5/16x12 | 81 | 43 | 36 |
| 10370-16-16-SM | 25 | 1 | -16 | 25.4 | 1 5/16x12 | 94 | 47 | 36 |

Approved **fitting series** for hose types, depending on size:

70 371LT 372 372RH 372TC 701 701 TC F42-8

06 Female JIC 37° – Swivel Straight

ISO12151-5-SWS – DKJ

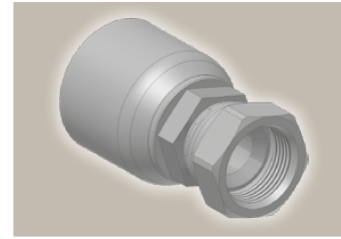
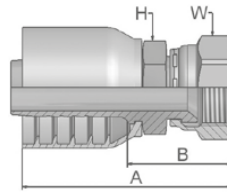

| Part Number | Hose I.D. | | | | Thread UNF | A mm | B mm | H mm | W mm |
|----------------|---------------|------|------|------|-------------------|---------|---------|-------------|-------------|
| | DN | Inch | Size | mm | | | | | |
| 10670-6-6-SM | 10 | 3/8 | -6 | 9.5 | 9/16x18 | 58 | 29 | 17 | 19 |
| 10670-8-6-SM | 10 | 3/8 | -6 | 9.5 | 3/4x16 | 61 | 32 | 19 | 22 |
| 10670-8-8-SM* | 12 | 1/2 | -8 | 12.7 | 3/4x16 | 67 | 32 | 22 | 22 |
| 10670-12-8-SM | 12 | 1/2 | -8 | 12.7 | 1 1/16x12 | 71 | 36 | 27 | 32 |
| 10670-10-10-SM | 16 | 5/8 | -10 | 15.9 | 7/8x14 | 75 | 35 | 24 | 27 |
| 10670-12-10-SM | 16 | 5/8 | -10 | 15.9 | 1 1/16x12 | 79 | 39 | 27 | 32 |
| 10670-12-12-SM | 19 | 3/4 | -12 | 19.1 | 1 1/16x12 | 80 | 41 | 27 | 32 |
| 10670-14-12-SM | 19 | 3/4 | -12 | 19.1 | 1 3/16x12 | 81 | 42 | 32 | 36 |
| 10670-16-12-SM | 19 | 3/4 | -12 | 19.1 | 1 5/16x12 | 84 | 45 | 32 | 41 |
| 10670-12-16-SM | 25 | 1 | -16 | 25.4 | 1 1/16x12 | 89 | 44 | 36 | 32 |
| 10670-16-16-SM | 25 | 1 | -16 | 25.4 | 1 5/16x12 | 94 | 47 | 36 | 41 |
| 10670-20-16-SM | 25 | 1 | -16 | 25.4 | 1 5/8x12 | 98 | 52 | 41 | 50 |

* These fittings contain a dual seat that accepts both JIC (37°) and SAE (45°) male configurations.

70 Series

Approved **fitting series** for hose types, depending on size:

70 | 371LT | 372 | 372RH | 372TC | 701 | 701 TC | F42-8



Db-9

Catalogue 4400/UK

37 Female JIC 37° – Swivel 45° Elbow

ISO 12151-5-SWE 45° – DKJ 45°

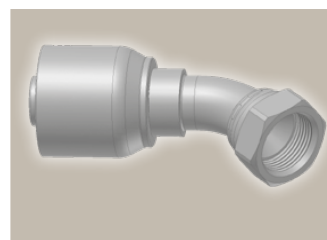
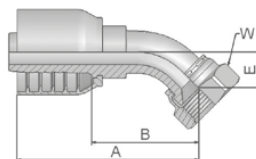

| Part Number | Hose I.D. | | | | Thread UNF | A mm | B mm | E mm | W mm |
|-----------------|-----------|------|------|------|---------------|---------|---------|---------|---------|
| | DN | Inch | Size | mm | | | | | |
| 13770-6-6-SM | 10 | 3/8 | -6 | 9.5 | 9/16x18 | 61 | 32 | 11 | 19 |
| 13770-8-8-SM* | 12 | 1/2 | -8 | 12.7 | 3/4x16 | 73 | 38 | 14 | 22 |
| 13770-10-8-SM* | 12 | 1/2 | -8 | 12.7 | 7/8x14 | 78 | 43 | 17 | 27 |
| 13770-8-10-SM* | 16 | 5/8 | -10 | 15.9 | 3/4x16 | 78 | 39 | 15 | 22 |
| 13770-10-10-SM* | 16 | 5/8 | -10 | 15.9 | 7/8x14 | 83 | 42 | 16 | 27 |
| 13770-12-10-SM | 16 | 5/8 | -10 | 15.9 | 1 1/16x12 | 88 | 48 | 21 | 32 |
| 13770-12-12-SM | 19 | 3/4 | -12 | 19.1 | 1 1/16x12 | 91 | 52 | 20 | 32 |
| 13770-16-16-SM | 25 | 1 | -16 | 25.4 | 1 5/16x12 | 111 | 66 | 24 | 41 |
| 13770-20-16-SM | 25 | 1 | -16 | 25.4 | 1 5/8x12 | 114 | 67 | 26 | 50 |

* These fittings contain a dual seat that accepts both JIC (37°) and SAE (45°) male configurations.

39/3W Female JIC 37° SAE 45° – Dual Flare Swivel Female 90° Elbow

ISO 12151-5-SWES – DKJ 90°

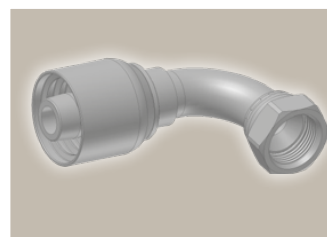
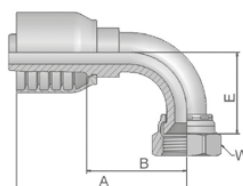

| Part Number | Hose I.D. | | | | Thread UNF | A mm | B mm | E mm | W mm |
|----------------|-----------|------|------|------|---------------|---------|---------|---------|---------|
| | DN | Inch | Size | mm | | | | | |
| 13970-6-6-SM | 10 | 3/8 | -6 | 9.5 | 9/16x18 | 57 | 28 | 23 | 19 |
| 13W70-8-6-SM | 10 | 3/8 | -6 | 9.5 | 3/4x16 | 64 | 35 | 29 | 22 |
| 13970-12-10-SM | 16 | 5/8 | -10 | 15.9 | 1 1/16x12 | 87 | 48 | 48 | 32 |
| 13970-12-12-SM | 19 | 3/4 | -12 | 19.1 | 1 1/16x12 | 89 | 50 | 48 | 32 |
| 13970-16-12-SM | 19 | 3/4 | -12 | 19.1 | 1 5/16x12 | 89 | 49 | 56 | 41 |
| 13970-12-16-SM | 25 | 1 | -16 | 25.4 | 1 1/16x12 | 99 | 54 | 46 | 32 |
| 13970-16-16-SM | 25 | 1 | -16 | 25.4 | 1 5/16x12 | 109 | 64 | 56 | 41 |
| 13970-20-16-SM | 25 | 1 | -16 | 25.4 | 1 5/8x12 | 111 | 64 | 62 | 50 |

* These fittings contain a dual seat that accepts both JIC (37°) and SAE (45°) male configurations.

Approved **fitting series** for hose types, depending on size:

70 371LT 372 372RH 372TC 701 701 TC F42-8

15 ISO 6162-1-Flange Straight

ISO 12151-3-S-L – SFL
(21.0 MPa/ 3000 psi)

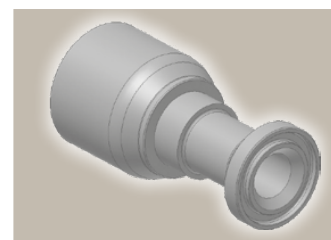
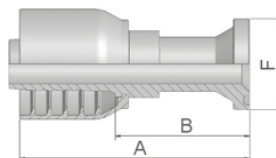

| Part Number | Hose I.D. | | | | Flange Inch | A mm | B mm | F mm |
|-------------|-----------|------|------|------|----------------|---------|---------|---------|
| | DN | Inch | Size | mm | | | | |
| 11570-8-8 | 12 | 1/2 | -8 | 12.7 | 1/2 | 89 | 54 | 30 |
| 11570-10-10 | 16 | 5/8 | -10 | 15.9 | 5/8 | 116 | 79 | 34 |
| 11570-12-10 | 16 | 5/8 | -10 | 15.9 | 3/4 | 69 | 30 | 38 |
| 11570-12-12 | 19 | 3/4 | -12 | 19.1 | 3/4 | 98 | 59 | 38 |
| 11570-16-12 | 19 | 3/4 | -12 | 19.1 | 1 | 70 | 31 | 45 |
| 11570-20-12 | 19 | 3/4 | -12 | 19.1 | 1 1/4 | 75 | 36 | 51 |
| 11570-12-16 | 25 | 1 | -16 | 25.4 | 3/4 | 111 | 66 | 38 |
| 11570-16-16 | 25 | 1 | -16 | 25.4 | 1 | 108 | 63 | 45 |
| 11570-20-16 | 25 | 1 | -16 | 25.4 | 1 1/4 | 82 | 36 | 51 |

SAE flange halves see in section Eb.

Fittings with standard O-ring seals can be used for temperatures from -40 °C up to +105 °C.
O-rings see section Eb. Special O-rings are available on request.

17 ISO 6162-1 Flange 45° Elbow

ISO 12151-3 – E45 – L – SFL 45°
(21.0 MPa/ 3000 psi)

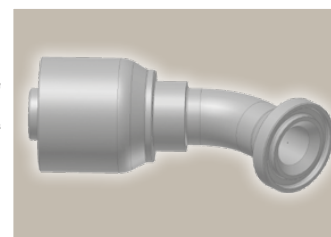
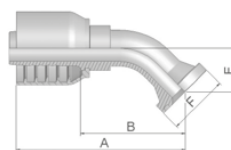

| Part Number | Hose I.D. | | | | Flange Inch | A mm | B mm | E mm | F mm |
|-------------|-----------|------|------|------|----------------|---------|---------|---------|---------|
| | DN | Inch | Size | mm | | | | | |
| 11770-8-8 | 12 | 1/2 | -8 | 12.7 | 1/2 | 79 | 44 | 20 | 30 |
| 11770-10-10 | 16 | 5/8 | -10 | 15.9 | 5/8 | 104 | 67 | 24 | 34 |
| 11770-12-10 | 16 | 5/8 | -10 | 15.9 | 3/4 | 96 | 57 | 26 | 38 |
| 11770-12-12 | 19 | 3/4 | -12 | 19.1 | 3/4 | 98 | 58 | 26 | 38 |
| 11770-16-12 | 19 | 3/4 | -12 | 19.1 | 1 | 97 | 57 | 25 | 45 |
| 11770-16-16 | 25 | 1 | -16 | 25.4 | 1 | 119 | 73 | 27 | 45 |
| 11770-20-16 | 25 | 1 | -16 | 25.4 | 1 1/4 | 121 | 76 | 32 | 51 |

SAE flange halves see in section Eb.

Fittings with standard O-ring seals can be used for temperatures from -40 °C up to +105 °C.
O-rings see section Eb. Special O-rings are available on request.

Approved **fitting series** for hose types, depending on size:

70 371LT 372 372RH 372TC 701 701 TC F42-8

19 ISO 6162-1-Flange 90° Elbow

ISO 12151-3 – E– L – SFL 90°
(21.0 MPa/ 3000 psi)

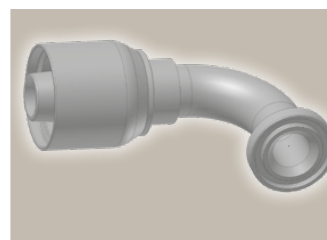
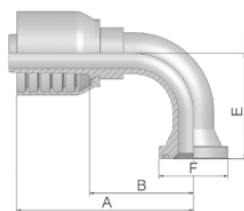

| Part Number | Hose I.D. | | | | Flange Inch | A mm | B mm | E mm | F mm |
|-------------|-----------|------|------|------|----------------|---------|---------|---------|---------|
| | DN | Inch | Size | mm | | | | | |
| 11970-8-8 | 12 | 1/2 | -8 | 12.7 | 1/2 | 75 | 40 | 41 | 30 |
| 11970-12-8 | 12 | 1/2 | -8 | 12.7 | 3/4 | 77 | 42 | 42 | 38 |
| 11970-10-10 | 16 | 5/8 | -10 | 15.9 | 5/8 | 92 | 55 | 55 | 34 |
| 11970-12-10 | 16 | 5/8 | -10 | 15.9 | 3/4 | 95 | 65 | 54 | 38 |
| 11970-12-12 | 19 | 3/4 | -12 | 19.1 | 3/4 | 89 | 50 | 58 | 38 |
| 11970-16-12 | 19 | 3/4 | -12 | 19.1 | 1 | 90 | 50 | 58 | 45 |
| 11970-16-16 | 25 | 1 | -16 | 25.4 | 1 | 105 | 55 | 61 | 45 |
| 11970-20-16 | 25 | 1 | -16 | 25.4 | 1 1/4 | 113 | 68 | 70 | 51 |

SAE flange halves see in section Eb.

Fittings with standard O-ring seals can be used for temperatures from -40 °C up to +105 °C.
O-rings see section Eb. Special O-rings are available on request.

6A ISO 6162-2-Flange Straight

ISO 12151-3-S-S – SFS
(42.0 MPa/ 6000 psi)

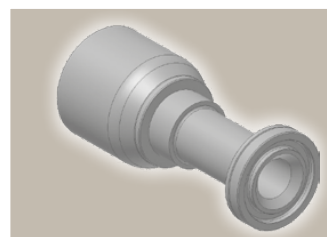
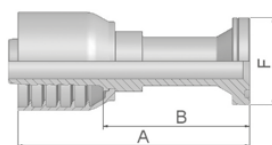

| Part Number | Hose I.D. | | | | Flange Inch | A mm | B mm | F mm |
|-------------|-----------|------|------|------|----------------|---------|---------|---------|
| | DN | Inch | Size | mm | | | | |
| 16A70-8-8 | 12 | 1/2 | -8 | 12.7 | 1/2 | 103 | 68 | 32 |
| 16A70-12-8 | 12 | 1/2 | -8 | 12.7 | 3/4 | 105 | 70 | 41 |
| 16A70-8-10 | 16 | 5/8 | -10 | 15.9 | 1/2 | 107 | 68 | 32 |
| 16A70-12-10 | 16 | 5/8 | -10 | 15.9 | 3/4 | 117 | 78 | 41 |
| 16A70-8-12 | 19 | 3/4 | -12 | 19.1 | 1/2 | 107 | 67 | 32 |
| 16A70-12-12 | 19 | 3/4 | -12 | 19.1 | 3/4 | 105 | 66 | 41 |
| 16A70-16-12 | 19 | 3/4 | -12 | 19.1 | 1 | 110 | 70 | 48 |
| 16A70-12-16 | 25 | 1 | -16 | 25.4 | 3/4 | 127 | 82 | 41 |
| 16A70-16-16 | 25 | 1 | -16 | 25.4 | 1 | 127 | 82 | 48 |
| 16A70-20-16 | 25 | 1 | -16 | 25.4 | 1 1/4 | 127 | 82 | 54 |

SAE flange halves see in section Eb.

Fittings with standard O-ring seals can be used for temperatures from -40 °C up to +105 °C.
O-rings see section Eb. Special O-rings are available on request.

Approved **fitting series** for hose types, depending on size:

70 371LT 372 372RH 372TC 701 701 TC F42-8

6F ISO 6162-2-Flange 45° Elbow – Heavy Series

ISO 12151-3 – E45-S – SFS 45°
(42.0 MPa/ 6000 psi)

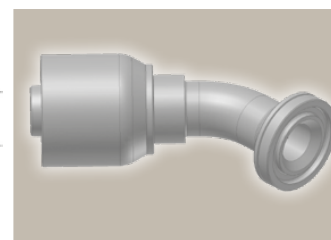
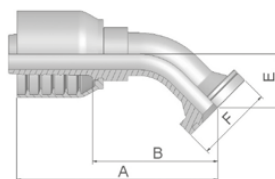

| Part Number | Hose I.D. | | | | Flange Inch | A mm | B mm | E mm | F mm |
|-------------|-----------|------|------|------|----------------|---------|---------|---------|---------|
| | DN | Inch | Size | mm | | | | | |
| 16F70-8-8 | 12 | 1/2 | -8 | 12.7 | 1/2 | 81 | 46 | 19 | 32 |
| 16F70-12-8 | 12 | 1/2 | -8 | 12.7 | 3/4 | 90 | 55 | 26 | 41 |
| 16F70-8-10 | 16 | 5/8 | -10 | 15.9 | 1/2 | 92 | 53 | 26 | 32 |
| 16F70-12-10 | 16 | 5/8 | -10 | 15.9 | 3/4 | 92 | 55 | 26 | 41 |
| 16F70-8-12 | 19 | 3/4 | -12 | 19.1 | 1/2 | 94 | 54 | 26 | 32 |
| 16F70-12-12 | 19 | 3/4 | -12 | 19.1 | 3/4 | 105 | 66 | 26 | 41 |
| 16F70-16-12 | 19 | 3/4 | -12 | 19.1 | 1 | 101 | 62 | 26 | 48 |
| 16F70-12-16 | 25 | 1 | -16 | 25.4 | 3/4 | 118 | 73 | 27 | 41 |
| 16F70-16-16 | 25 | 1 | -16 | 25.4 | 1 | 117 | 77 | 27 | 48 |
| 16F70-20-16 | 25 | 1 | -16 | 25.4 | 1 1/4 | 117 | 70 | 31 | 54 |

SAE flange halves see in section Eb.

Fittings with standard O-ring seals can be used for temperatures from -40 °C up to +105 °C.
O-rings see section Eb. Special O-rings are available on request.

6N ISO 6162-2-Flange 90° Elbow

ISO 12151-3 – E-S – SFS 90°
(42.0 MPa/ 6000 psi)

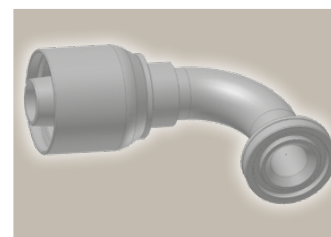
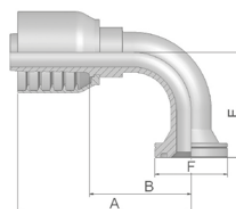

| Part Number | Hose I.D. | | | | Flange Inch | A mm | B mm | E mm | F mm |
|-------------|-----------|------|------|------|----------------|---------|---------|---------|---------|
| | DN | Inch | Size | mm | | | | | |
| 16N70-8-8 | 12 | 1/2 | -8 | 12.7 | 1/2 | 74 | 39 | 41 | 32 |
| 16N70-12-8 | 12 | 1/2 | -8 | 12.7 | 3/4 | 79 | 44 | 45 | 41 |
| 16N70-8-10 | 16 | 5/8 | -10 | 15.9 | 1/2 | 95 | 56 | 54 | 32 |
| 16N70-12-10 | 16 | 5/8 | -10 | 15.9 | 3/4 | 92 | 55 | 54 | 41 |
| 16N70-16-10 | 16 | 5/8 | -10 | 15.9 | 1 | 86 | 46 | 54 | 48 |
| 16N70-8-12 | 19 | 3/4 | -12 | 19.1 | 1/2 | 81 | 42 | 54 | 32 |
| 16N70-12-12 | 19 | 3/4 | -12 | 19.1 | 3/4 | 98 | 58 | 54 | 41 |
| 16N70-16-12 | 19 | 3/4 | -12 | 19.1 | 1 | 92 | 53 | 53 | 48 |
| 16N70-12-16 | 25 | 1 | -16 | 25.4 | 3/4 | 113 | 66 | 57 | 41 |
| 16N70-16-16 | 25 | 1 | -16 | 25.4 | 1 | 111 | 64 | 70 | 48 |
| 16N70-20-16 | 25 | 1 | -16 | 25.4 | 1 1/4 | 115 | 68 | 68 | 54 |

SAE flange halves see in section Eb.

Fittings with standard O-ring seals can be used for temperatures from -40 °C up to +105 °C.
O-rings see section Eb. Special O-rings are available on request.

Approved **fitting series** for hose types, depending on size:

70 371LT 372 372RH 372TC 701 701 TC F42-8

High Pressure
Flange

Parkrimp No-Skive Fittings
70 Series

PY Flange - 24° Male
French Gas
Straight

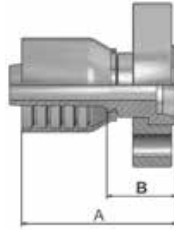

| Part Number |  Hose I.D. | | | | A mm | B mm |
|-------------|------------------------------------------------------------------------------------------------|------|------|------|---------|---------|
| | DN | Inch | Size | mm | | |
| 1PY70-10-10 | 16 | 5/8 | -10 | 15.9 | 63 | 24 |
| 1PY70-12-12 | 19 | 3/4 | -12 | 19.1 | 69 | 30 |
| 1PY70-16-16 | 25 | 1 | -16 | 25.4 | 87 | 41 |

Approved **fitting series** for hose types, depending on size:

70 371LT 372 372RH 372TC 701 701 TC F42-8



Db-14

Catalogue 4400/UK

JC Female ORFS Swivel – Straight Short

ISO 12151-1 – SWSA
SAE J516 – ORFS

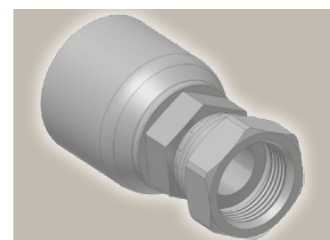
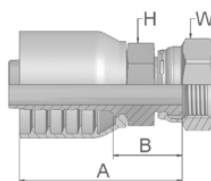

| Part Number | Hose I.D. | | | | Thread UNF | A mm | B mm | H mm | W mm |
|----------------|-----------|------|------|------|---------------|---------|---------|---------|---------|
| | DN | Inch | Size | mm | | | | | |
| 1JC70-6-6-SM | 10 | 3/8 | -6 | 9.5 | 11/16x16 | 49 | 20 | 19 | 22 |
| 1JC70-8-6-SM | 10 | 3/8 | -6 | 9.5 | 13/16x16 | 51 | 22 | 19 | 24 |
| 1JC70-8-8-SM | 12 | 1/2 | -8 | 12.7 | 13/16x16 | 56 | 24 | 13/16 | 15/16 |
| 1JC70-10-8-SM | 12 | 1/2 | -8 | 12.7 | 1x14 | 58 | 24 | 24 | 30 |
| 1JC70-12-8-SM | 12 | 1/2 | -8 | 12.7 | 1 3/16x12 | 63 | 28 | 32 | 36 |
| 1JC70-8-10-SM | 16 | 5/8 | -10 | 15.9 | 13/16x16 | 58 | 22 | 24 | 24 |
| 1JC70-10-10-SM | 16 | 5/8 | -10 | 15.9 | 1x14 | 64 | 24 | 24 | 30 |
| 1JC70-12-10-SM | 16 | 5/8 | -10 | 15.9 | 1 3/16x12 | 68 | 29 | 32 | 36 |
| 1JC70-8-12-SM | 19 | 3/4 | -12 | 19.1 | 13/16x16 | 61 | 22 | 27 | 24 |
| 1JC70-12-12-SM | 19 | 3/4 | -12 | 19.1 | 1 3/16x12 | 68 | 29 | 32 | 36 |
| 1JC70-16-12-SM | 19 | 3/4 | -12 | 19.1 | 1 7/16x12 | 72 | 33 | 36 | 41 |
| 1JC70-12-16-SM | 25 | 1 | -16 | 25.4 | 13/16x12 | 76 | 31 | 36 | 36 |
| 1JC70-16-16-SM | 25 | 1 | -16 | 25.4 | 1 7/16x12 | 80 | 35 | 36 | 41 |
| 1JC70-20-16-SM | 25 | 1 | -16 | 25.4 | 1 11/16x12 | 80 | 33 | 41 | 50 |

JS ORFS Swivel Female (Long)

ISO 12151-1-SWSB
SAE J516 – ORFS

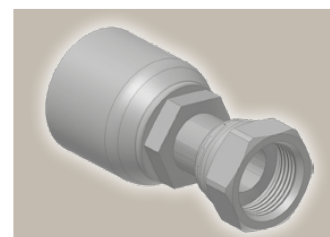
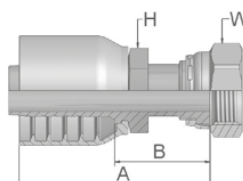

| Part Number | Hose I.D. | | | | Thread UNF | A mm | B mm | H mm | W mm |
|----------------|-----------|------|------|------|---------------|---------|---------|---------|---------|
| | DN | Inch | Size | mm | | | | | |
| 1JS70-6-6-SM | 10 | 3/8 | -6 | 9.5 | 11/16x16 | 58 | 29 | 17 | 22 |
| 1JS70-8-6-SM | 10 | 3/8 | -6 | 9.5 | 13/16x16 | 64 | 35 | 19 | 24 |
| 1JS70-8-8-SM | 12 | 1/2 | -8 | 12.7 | 13/16x16 | 67 | 33 | 22 | 24 |
| 1JS70-10-8-SM | 12 | 1/2 | -8 | 12.7 | 1x14 | 73.5 | 38.5 | 24 | 30 |
| 1JS70-10-10-SM | 16 | 5/8 | -10 | 15.9 | 1x14 | 79 | 39 | 24 | 30 |
| 1JS70-12-12-SM | 19 | 3/4 | -12 | 19.1 | 1 3/16x12 | 84 | 45 | 30 | 36 |
| 1JS70-16-12-SM | 19 | 3/4 | -12 | 19.1 | 1 7/16x12 | 86 | 47 | 36 | 41 |
| 1JS70-16-16-SM | 25 | 1 | -16 | 25.4 | 1 7/16x12 | 98 | 53 | 36 | 41 |
| 1JS70-20-16-SM | 25 | 1 | -16 | 25.4 | 1 11/16x12 | 94 | 47 | 41 | 50 |

70 Series

Approved **fitting series** for hose types, depending on size:

70 371LT 372 372RH 372TC 701 701 TC F42-8



J7 Female ORFS – Swivel 45° Elbow

ISO 12151-1 – SWE 45°
SAE J516 – ORFS 45°

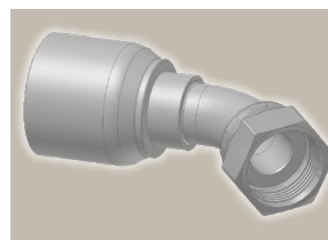
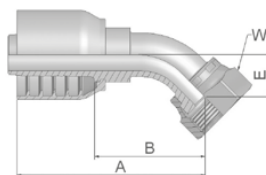

| Part Number | Hose I.D. | | | | Thread UNF | A mm | B mm | E mm | W mm |
|----------------|-----------|------|------|------|---------------|---------|---------|---------|---------|
| | DN | Inch | Size | mm | | | | | |
| 1J770-6-6-SM | 10 | 3/8 | -6 | 9.5 | 11/16x16 | 62 | 33 | 11 | 22 |
| 1J770-8-6-SM | 10 | 3/8 | -6 | 9.5 | 13/16x16 | 64 | 35 | 15 | 24 |
| 1J770-6-8-SM | 12 | 1/2 | -8 | 12.7 | 11/16x16 | 68 | 33 | 11 | 22 |
| 1J770-8-8-SM | 12 | 1/2 | -8 | 12.7 | 13/16x16 | 72 | 37 | 15 | 24 |
| 1J770-10-8-SM | 12 | 1/2 | -8 | 12.7 | 1x14 | 80 | 46 | 17 | 30 |
| 1J770-10-10-SM | 16 | 5/8 | -10 | 15.9 | 1x14 | 83 | 44 | 16 | 30 |
| 1J770-12-10-SM | 16 | 5/8 | -10 | 15.9 | 1 3/16x12 | 90 | 53 | 21 | 36 |
| 1J770-12-12-SM | 19 | 3/4 | -12 | 19.1 | 1 3/16x12 | 92 | 53 | 21 | 36 |
| 1J770-16-12-SM | 19 | 3/4 | -12 | 19.1 | 1 7/16x12 | 95 | 56 | 24 | 41 |
| 1J770-16-16-SM | 25 | 1 | -16 | 25.4 | 1 7/16x12 | 113 | 66 | 24 | 41 |

J9 Female ORFS – Swivel 90° Elbow – Short Drop

ISO 12151-1 – SWES
SAE J516 – ORFS 90°

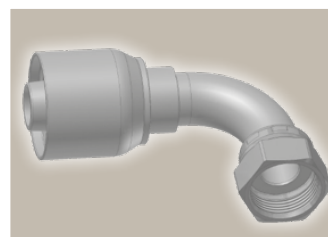
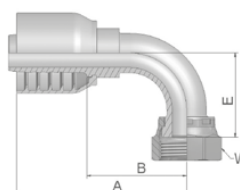

| Part Number | Hose I.D. | | | | Thread UNF | A mm | B mm | E mm | W mm |
|----------------|-----------|------|------|------|---------------|---------|---------|---------|---------|
| | DN | Inch | Size | mm | | | | | |
| 1J970-6-6-SM | 10 | 3/8 | -6 | 9.5 | 11/16x16 | 58 | 29 | 23 | 22 |
| 1J970-8-6-SM | 10 | 3/8 | -6 | 9.5 | 13/16x16 | 58 | 29 | 29 | 24 |
| 1J970-8-8-SM | 12 | 1/2 | -8 | 12.7 | 13/16x16 | 70 | 35 | 29 | 24 |
| 1J970-10-8-SM | 12 | 1/2 | -8 | 12.7 | 1x14 | 73 | 38 | 32 | 30 |
| 1J970-12-8-SM | 12 | 1/2 | -8 | 12.7 | 1 3/16x12 | 76 | 41 | 48 | 36 |
| 1J970-10-10-SM | 16 | 5/8 | -10 | 15.9 | 1x14 | 78 | 39 | 33 | 30 |
| 1J970-12-10-SM | 16 | 5/8 | -10 | 15.9 | 1 3/16x12 | 86 | 50 | 48 | 36 |
| 1J970-12-12-SM | 19 | 3/4 | -12 | 19.1 | 1 3/16x12 | 89 | 49 | 48 | 36 |
| 1J970-16-12-SM | 19 | 3/4 | -12 | 19.1 | 1 7/16x12 | 89 | 49 | 56 | 41 |
| 1J970-16-16-SM | 25 | 1 | -16 | 25.4 | 1 7/16x12 | 111 | 64 | 56 | 41 |
| 1J970-20-16-SM | 25 | 1 | -16 | 25.4 | 1 11/16x12 | 111 | 64 | 64 | 50 |

Approved **fitting series** for hose types, depending on size:

70 371LT 372 372RH 372TC 701 701 TC F42-8

J1 Female ORFS – Swivel 90° Elbow – Long Drop

ISO 12151-1 – SWEL
SAE J 516 – ORFS 90° L

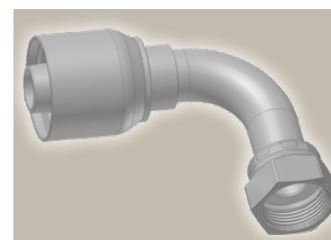
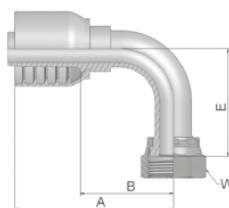

| Part Number | Hose I.D. | | | | Thread UNF | A mm | B mm | E mm | W mm |
|----------------|-----------|------|------|------|---------------|---------|---------|---------|---------|
| | DN | Inch | Size | mm | | | | | |
| 1J170-8-8-SM | 12 | 1/2 | -8 | 12.7 | 13/16x16 | 71 | 36 | 64 | 24 |
| 1J170-10-8-SM | 12 | 1/2 | -8 | 12.7 | 1x14 | 73 | 38 | 70 | 30 |
| 1J170-10-10-SM | 16 | 5/8 | -10 | 15.9 | 1x14 | 78 | 39 | 70 | 30 |
| 1J170-12-10-SM | 16 | 5/8 | -10 | 15.9 | 1 3/16x12 | 76 | 40 | 96 | 36 |
| 1J170-12-12-SM | 19 | 3/4 | -12 | 19.1 | 1 3/16x12 | 89 | 49 | 96 | 36 |
| 1J170-16-16-SM | 25 | 1 | -16 | 25.4 | 1 7/16x12 | 109 | 64 | 114 | 41 |

JM ORFS Male

ISO 12151-1-S – SAE J516

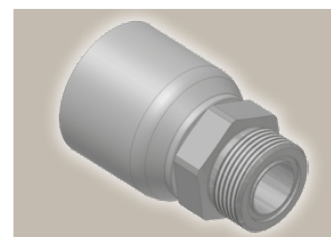
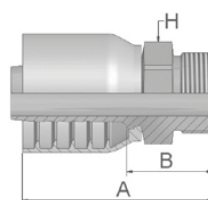

| Part Number | Hose I.D. | | | | Thread UNF | A mm | B mm | H mm |
|----------------|-----------|------|------|------|---------------|---------|---------|---------|
| | DN | Inch | Size | mm | | | | |
| 1JM70-6-6-SM | 10 | 3/8 | -6 | 9.5 | 11/16x16 | 53 | 24 | 19 |
| 1JM70-8-6-SM | 10 | 3/8 | -6 | 9.5 | 13/16x16 | 56 | 27 | 22 |
| 1JM70-8-8-SM | 12 | 1/2 | -8 | 12.7 | 13/16x16 | 62 | 27 | 22 |
| 1JM70-10-8-SM | 12 | 1/2 | -8 | 12.7 | 1x14 | 66 | 32 | 27 |
| 1JM70-10-10-SM | 16 | 5/8 | -10 | 15.9 | 1x14 | 68 | 32 | 27 |
| 1JM70-12-10-SM | 16 | 5/8 | -10 | 15.9 | 1 3/16x12 | 71 | 34 | 32 |
| 1JM70-12-12-SM | 19 | 3/4 | -12 | 19.1 | 1 3/16x12 | 74 | 34 | 32 |
| 1JM70-16-12-SM | 19 | 3/4 | -12 | 19.1 | 1 7/16x12 | 74 | 35 | 41 |
| 1JM70-16-16-SM | 25 | 1 | -16 | 25.4 | 1 7/16x12 | 84 | 39 | 41 |
| 1JM70-20-16-SM | 25 | 1 | -16 | 25.4 | 1 11/16x12 | 82 | 37 | 46 |

JM fittings are supplied without O-ring.
O-rings see section Eb. Special O-rings are available on request.

Approved **fitting series** for hose types, depending on size:

70 371LT 372 372RH 372TC 701 701 TC F42-8

XU Female Metric – Swivel Straight (30° Flare)

JIS B8363

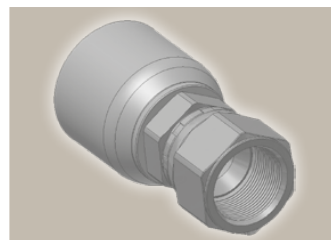
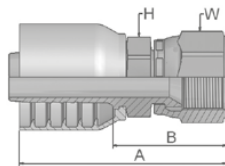

| Part Number | Hose I.D. | | | | Thread metric | A mm | B mm | H mm | W mm |
|-------------|-----------|------|------|------|------------------|---------|---------|---------|---------|
| | DN | Inch | Size | mm | | | | | |
| 1XU70-10-10 | 16 | 5/8 | -10 | 15.9 | M24x1.5 | 67 | 28 | 30 | 32 |
| 1XU70-12-12 | 19 | 3/4 | -12 | 19.1 | M30x1.5 | 68 | 28 | 32 | 36 |
| 1XU70-16-16 | 25 | 1 | -16 | 25.4 | M33x1.5 | 82 | 35 | 36 | 41 |

XY Female Metric – Swivel 90° Elbow (30° Flare)

JIS B8363

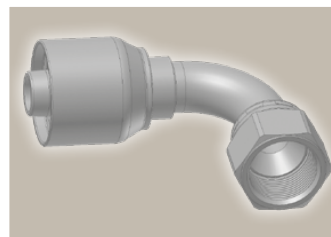
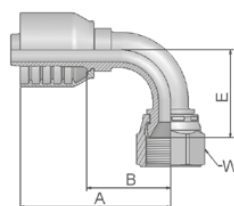

| Part Number | Hose I.D. | | | | Thread metric | A mm | B mm | E mm | W mm |
|-------------|-----------|------|------|------|------------------|---------|---------|---------|---------|
| | DN | Inch | Size | mm | | | | | |
| 1XY70-10-10 | 16 | 5/8 | -10 | 15.9 | M24x1.5 | 77 | 41 | 41 | 32 |
| 1XY70-12-12 | 19 | 3/4 | -12 | 19.1 | M24x1.5 | 89 | 49 | 52 | 36 |





Approved **fitting series** for hose types, depending on size:

70 371LT 372 372RH 372TC 701 701 TC F42-8



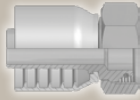
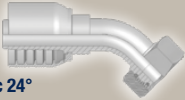

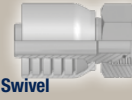
DIN – Metric

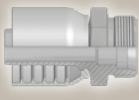
Page Dc-1 – Dc-4

| | | | |
|----------------------------------------------------------------------------------------------------------------------------------------------------------------------------------------------------------------------------------|----------------------------------------------------------------------------------------------------------------------------------------------------------------------------------------------------------------------------------|-----------------------------------------------------------------------------------------------------------------------------------------------------------------------------------------------------------------------------------|-------------------------------------------------------------------------------------------------------------------------------------------------------------------------------------------------------------------------------|
| <p>CA Dc-1</p>  <p>Female Metric 24° Light Series with O-Ring Swivel – Straight ISO 12151-2-SWS-L – DKOL</p> | <p>CE Dc-1</p>  <p>Female Metric 24° Light Series with O-Ring Swivel – 45° Elbow ISO 12151-2-SWE-L – DKOL 45°</p> | <p>CF Dc-2</p>  <p>Female Metric 24° Light Series with O-Ring Swivel – 90° Elbow ISO 12151-2-SWE-L – DKOL 90°</p> | <p>C9 Dc-2</p>  <p>Female Metric 24° – Swivel Heavy Series with O-Ring Straight ISO 12151-2-SWS-S – DKOS</p> |
| <p>OC Dc-3</p>  <p>Female Metric 24° – Swivel Heavy Series with O-Ring 45° Elbow ISO 12151-2-SWE-S – DKOS 45°</p> | <p>1C Dc-3</p>  <p>Female Metric 24° – Swivel Heavy Series with O-Ring 90° Elbow ISO 12151-2-SWE-S – DKOS 90°</p> | <p>D2 Dc-4</p>  <p>Male Metric 24° – Rigid Heavy Series – Straight ISO 12151-2-S-S – CES</p> | |

BSP

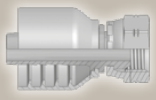
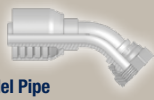
Page Dc-5 – Dc-6

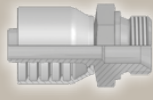





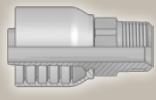
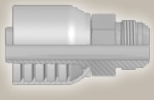
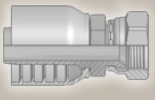
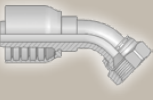
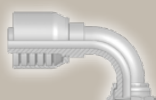

| | | | |
|--------------------------------------------------------------------------------------------------------------------------------------------------------------------------------------------------------|----------------------------------------------------------------------------------------------------------------------------------------------------------------------------------------------------------------|-----------------------------------------------------------------------------------------------------------------------------------------------------------------------------------------------------------------|-----------------------------------------------------------------------------------------------------------------------------------------------------------------------------------------------------|
| <p>92 Dc-5</p>  <p>Female BSP Parallel Pipe Swivel – Straight (60° Cone) BS5200-A – DKR</p> | <p>B1 Dc-5</p>  <p>Female BSP Parallel Pipe Swivel 45° Elbow (60° Cone) BS 5200-D – DKR 45°</p> | <p>B2 Dc-6</p>  <p>Female BSP Parallel Pipe Swivel 90° Elbow (60° Cone) BS 5200-B – DKR 90°</p> | <p>D9 Dc-6</p>  <p>Male BSP Parallel Pipe Rigid – Straight (60° Cone) BS5200 – AGR</p> |
|--------------------------------------------------------------------------------------------------------------------------------------------------------------------------------------------------------|----------------------------------------------------------------------------------------------------------------------------------------------------------------------------------------------------------------|-----------------------------------------------------------------------------------------------------------------------------------------------------------------------------------------------------------------|-----------------------------------------------------------------------------------------------------------------------------------------------------------------------------------------------------|

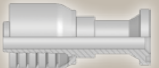
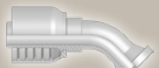
SAE

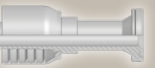
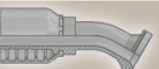



Page Dc-6 – Dc-8

| | | | |
|--------------------------------------------------------------------------------------------------------------------------------------------------------------------------------------------------|--------------------------------------------------------------------------------------------------------------------------------------------------------------------------------------|--------------------------------------------------------------------------------------------------------------------------------------------------------------------------------------------|-------------------------------------------------------------------------------------------------------------------------------------------------------------------------------------------------------|
| <p>01 Dc-7</p>  <p>Male NPTF Pipe Rigid – Straight SAE J476A / J516 – AGN</p> | <p>03 Dc-7</p>  <p>Male JIC 37° – Rigid Straight ISO12151-5-S – AGJ</p> | <p>06 Dc-8</p>  <p>Female JIC 37° – Swivel Straight ISO12151-5-SWS – DKJ</p> | <p>37 Dc-8</p>  <p>Female JIC 37° – Swivel 45° Elbow ISO 12151-5-SWE 45° – DKJ 45°</p> |
| <p>39 Dc-9</p>  <p>Female JIC 37° – Swivel 90° Elbow ISO 12151-5-SWES – DKJ 90°</p> | | | |

Flange

| Page Dc-10 – Dc-15 | | | |
|-------------------------------------------------------------------------------------------------------------------------------------------------------------------------------------------------------------|----------------------------------------------------------------------------------------------------------------------------------------------------------------------------------------------------------------------------------|-------------------------------------------------------------------------------------------------------------------------------------------------------------------------------------------------------------------|------------------------------------------------------------------------------------------------------------------------------------------------------------------------------------------------------------|
| <p>15/4A Dc-10</p>  <p>ISO 6162-1-Flange Straight ISO 12151-3-S-L – SFL (35.0 MPa/ 5000 psi)</p> | <p>17/4F Dc-10</p>  <p>ISO 6162-1-Flange 45° Elbow ISO 12151-3 – E45S – L – SFL 45° (35.0 MPa/ 5000 psi)</p> | <p>19/4N Dc-11</p>  <p>ISO 6162-1-Flange 90° Elbow ISO 12151-3-E-L – SFL 90° (35.0 MPa/ 5000 psi)</p> | <p>6A Dc-11</p>  <p>ISO 6162-2-Flange Straight ISO 12151-3-S-S – SFS (42.0 MPa/ 6000 psi)</p> |
| <p>6E Dc-12</p>  <p>ISO 6162-2-Flange 30° Elbow SFS 30° (42.0 MPa/ 6000 psi)</p> | <p>6F Dc-12</p>  <p>ISO 6162-2-Flange 45° Elbow – Heavy Series ISO 12151-3 – E45-S – SFS 45° (42.0 MPa/ 6000 psi)</p> | <p>6N Dc-13</p>  <p>ISO 6162-2-Flange 90° Elbow ISO 12151-3 – E-S – SFS 90° (42.0 MPa/ 6000 psi)</p> | <p>XA Dc-13</p>  <p>Caterpillar® Flange Straight</p> |
| <p>XF Dc-14</p>  <p>Caterpillar® Flange 45° Elbow</p> | <p>XG Dc-14</p>  <p>Caterpillar® Flange 60° Elbow</p> | <p>XN Dc-15</p>  <p>Caterpillar® Flange 90° Elbow</p> | |

ORFS

| Page Dc-16 – Dc-18 | | | |
|---------------------------------------------------------------------------------------------------------------------------------------------------------------------------------------------------------|---------------------------------------------------------------------------------------------------------------------------------------------------------------------------------------------|------------------------------------------------------------------------------------------------------------------------------------------------------------------------------------------------------------|-----------------------------------------------------------------------------------------------------------------------------------------------------------------------------------------------------------------------|
| <p>JC Dc-16</p>  <p>Female ORFS Swivel – Straight Short ISO 12151-1 – SWSA SAE J516 – ORFS</p> | <p>JS Dc-16</p>  <p>ORFS Swivel Female (Long) ISO 12151-1-SWSB SAE J516 – ORFS</p> | <p>J7 Dc-17</p>  <p>Female ORFS – Swivel 45° Elbow ISO 12151-1 – SWE 45° SAE J516 – ORFS 45°</p> | <p>J9 Dc-17</p>  <p>Female ORFS – Swivel 90° Elbow – Short Drop ISO 12151-1 – SWES SAE J516 – ORFS 90°</p> |
| <p>JM Dc-18</p>  <p>ORFS Male ISO 12151-1-S – SAE J516</p> | | | |

Others

| Page Dc-19 | |
|----------------------------------------------------------------------------------------------------------------------------------------------------------------------------------------|--|
| <p>XU Dc-19</p>  <p>Female Metric – Swivel Straight (30° Flare) JIS B8363</p> | |

A large range of special hose fittings for the MRO market can be found on page Dc-20

High Pressure
DIN – Metric

Parkrimp No-Skive Fittings
73 Series

CA **Female Metric 24°
Light Series with O-Ring
Swivel – Straight**

ISO 12151-2-SWS-L – DKOL

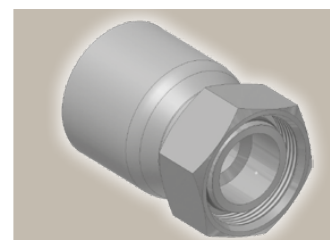
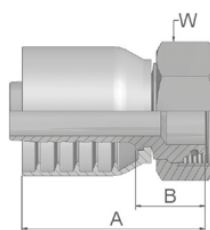

| Part Number | Hose I.D. | | | | Thread metric | Tube O.D. mm | A mm | B mm | W mm |
|-------------|-----------|-------|------|------|------------------|--------------------|---------|---------|---------|
| | DN | Inch | Size | mm | | | | | |
| 1CA73-28-16 | 25 | 1 | -16 | 25.4 | M36x2 | 28 | 87 | 36 | 41 |
| 1CA73-35-20 | 31 | 1 1/4 | -20 | 31.8 | M45x2 | 35 | 103 | 39 | 50 |
| 1CA73-42-24 | 38 | 1 1/2 | -24 | 38.1 | M52x2 | 42 | 104 | 41 | 60 |

Fittings with standard O-ring seals can be used for temperatures from -40 °C up to +105 °C.
O-rings see section Eb. Special O-rings are available on request.

CE **Female Metric 24°
Light Series with O-Ring
Swivel – 45° Elbow**

ISO 12151-2-SWE -L – DKOL 45°

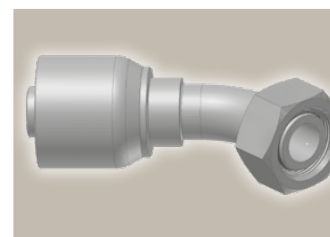
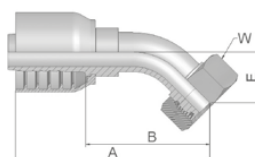

| Part Number | Hose I.D. | | | | Thread metric | Tube O.D. mm | A mm | B mm | W mm |
|-------------|-----------|-------|------|------|------------------|--------------------|---------|---------|---------|
| | DN | Inch | Size | mm | | | | | |
| 1CE73-35-20 | 31 | 1 1/4 | -20 | 31.8 | M45x2 | 35 | 162 | 97 | 37 |

Fittings with standard O-ring seals can be used for temperatures from -40 °C up to +105 °C.
O-rings see section Eb. Special O-rings are available on request.

73 Series

Approved **fitting series** for hose types:

| | | | | | | | | |
|-----------|-----|-------|------|--------|--------|------|--------|--------|
| 73 | 731 | 731TC | SX35 | SX35LT | SX35TC | SX42 | SX42LT | SX42TC |
|-----------|-----|-------|------|--------|--------|------|--------|--------|



Dc-1

Catalogue 4400/UK

High Pressure
DIN – Metric

Parkrimp No-Skive Fittings
73 Series

CF Female Metric 24° Light Series with O-Ring Swivel – 90° Elbow

ISO 12151-2-SWE-L – DKOL 90°

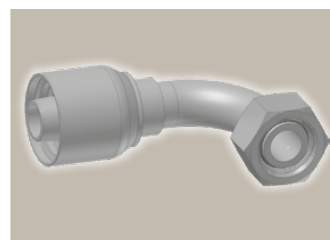
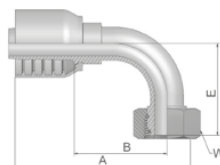

| Bestell-Nr. | Schlauch ID | | | | Gewinde metrisch | Rohr AD mm | A mm | B mm | E mm | W mm |
|-------------|-------------|-------|------|------|---------------------|------------------|---------|---------|---------|---------|
| | DN | Zoll | Size | mm | | | | | | |
| 1CF73-28-16 | 25 | 1 | -16 | 25.4 | - | - | - | - | - | - |
| 1CF73-35-20 | 31 | 1 1/4 | -20 | 31.8 | M45x2 | 35 | 150 | 86 | 79 | 50 |
| 1CF73-42-24 | 38 | 1 1/2 | -24 | 38.1 | - | - | - | - | - | - |

Fittings with standard O-ring seals can be used for temperatures from -40 °C up to +105 °C.
O-rings see section Eb. Special O-rings are available on request.

C9 Female Metric 24° – Swivel Heavy Series with O-Ring Straight

ISO 12151-2-SWS-S – DKOS

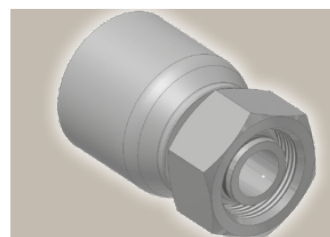
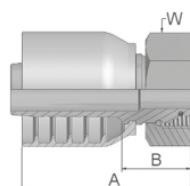

| Part Number | Hose I.D. | | | | Thread metric | Tube O.D. mm | A mm | B mm | W mm |
|-----------------|-----------|-------|------|------|------------------|--------------------|---------|---------|---------|
| | DN | Inch | Size | mm | | | | | |
| 1C973-20-12 | 19 | 3/4 | -12 | 19.1 | M30x2 | 20 | 81 | 33 | 36 |
| 1C973-25-12 | 19 | 3/4 | -12 | 19.1 | M36x2 | 25 | 79 | 31 | 46 |
| 1C973-25-12SW41 | 19 | 3/4 | -12 | 19.1 | M36x2 | 25 | 79 | 31 | 41 |
| 1C973-30-12 | 19 | 3/4 | -12 | 19.1 | M42x2 | 30 | 82 | 34 | 50 |
| 1C973-25-16 | 25 | 1 | -16 | 25.4 | M36x2 | 25 | 87 | 36 | 46 |
| 1C973-30-16 | 25 | 1 | -16 | 25.4 | M42x2 | 30 | 87 | 36 | 50 |
| 1C973-25-20 | 31 | 1 1/4 | -20 | 31.8 | M36x2 | 25 | 102 | 38 | 46 |
| 1C973-30-20 | 31 | 1 1/4 | -20 | 31.8 | M42x2 | 30 | 106 | 42 | 50 |
| 1C973-38-20 | 31 | 1 1/4 | -20 | 31.8 | M52x2 | 38 | 101 | 37 | 60 |
| 1C973-38-24 | 38 | 1 1/2 | -24 | 38.1 | M52x2 | 38 | 105 | 42 | 60 |

Fittings with standard O-ring seals can be used for temperatures from -40 °C up to +105 °C.
O-rings see section Eb. Special O-rings are available on request.

Approved **fitting series** for hose types:

73 | 731 | 731TC | SX35 | SX35LT | SX35TC | SX42 | SX42LT | SX42TC



Dc-2

Catalogue 4400/UK

0C Female Metric 24° – Swivel Heavy Series with O-Ring 45° Elbow

ISO 12151-2 – SWE -S – DKOS 45°

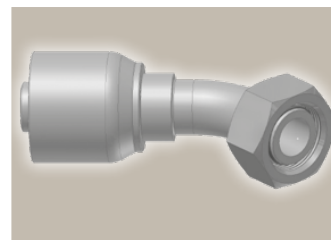
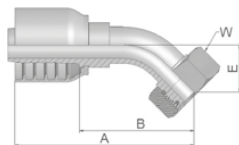

| Part Number | Hose I.D. | | | | Thread metric | Tube O.D. mm | A mm | B mm | E mm | W mm |
|-----------------|-----------|-------|------|------|------------------|--------------------|---------|---------|---------|---------|
| | DN | Inch | Size | mm | | | | | | |
| 10C73-20-12 | 19 | 3/4 | -12 | 19.1 | M30x2 | 20 | 113 | 65 | 30 | 36 |
| 10C73-25-12 | 19 | 3/4 | -12 | 19.1 | M36x2 | 25 | 112 | 64 | 29 | 46 |
| 10C73-25-12SW41 | 19 | 3/4 | -12 | 19.1 | M36x2 | 25 | 112 | 64 | 29 | 41 |
| 10C73-25-16 | 25 | 1 | -16 | 25.4 | M36x2 | 25 | 128 | 78 | 33 | 46 |
| 10C73-30-16 | 25 | 1 | -16 | 25.4 | M42x2 | 30 | 137 | 128 | 33 | 50 |
| 10C73-25-20 | 31 | 1 1/4 | -20 | 31.8 | M36x2 | 25 | 150 | 86 | 33 | 46 |
| 10C73-30-20 | 31 | 1 1/4 | -20 | 31.8 | M42x2 | 30 | 155 | 91 | 34 | 50 |
| 10C73-38-20 | 31 | 1 1/4 | -20 | 31.8 | M52x2 | 38 | 161 | 97 | 37 | 60 |
| 10C73-38-24 | 38 | 1 1/2 | -24 | 38.1 | M52x2 | 38 | 182 | 120 | 49 | 60 |

Fittings with standard O-ring seals can be used for temperatures from -40 °C up to +105 °C.
O-rings see section Eb. Special O-rings are available on request.

1C Female Metric 24° – Swivel Heavy Series with O-Ring 90° Elbow

ISO 12151-2-SWE-S – DKOS 90°

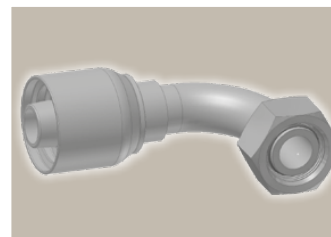
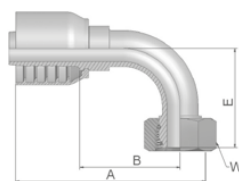

| Part Number | Hose I.D. | | | | Thread metric | Tube O.D. mm | A mm | B mm | E mm | W mm |
|-----------------|-----------|-------|------|------|------------------|--------------------|---------|---------|---------|---------|
| | DN | Inch | Size | mm | | | | | | |
| 11C73-20-12 | 19 | 3/4 | -12 | 19.1 | M30x2 | 20 | 101 | 53 | 60 | 36 |
| 11C73-25-12 | 19 | 3/4 | -12 | 19.1 | M36x2 | 25 | 101 | 53 | 59 | 46 |
| 11C73-25-12SW41 | 19 | 3/4 | -12 | 19.1 | M36x2 | 25 | 101 | 53 | 59 | 41 |
| 11C73-25-16 | 25 | 1 | -16 | 25.4 | M36x2 | 25 | 117 | 67 | 69 | 46 |
| 11C73-30-16 | 25 | 1 | -16 | 25.4 | M42x2 | 30 | 118 | 67 | 69 | 50 |
| 11C73-30-20 | 31 | 1 1/4 | -20 | 31.8 | M42x2 | 30 | 137 | 73 | 73 | 50 |
| 11C73-38-20 | 31 | 1 1/4 | -20 | 31.8 | M52x2 | 38 | 151 | 87 | 78 | 60 |
| 11C73-38-24 | 38 | 1 1/2 | -24 | 38.1 | M52x2 | 38 | 166 | 103 | 101 | 60 |
| 11C73-38-32 | 51 | 2 | -32 | 50.8 | M52x2 | 38 | 224 | 152 | 166 | 60 |

Fittings with standard O-ring seals can be used for temperatures from -40 °C up to +105 °C.
O-rings see section Eb. Special O-rings are available on request.

73 Series

Approved **fitting series** for hose types:



| | | | | | | | | |
|----|-----|-------|------|--------|--------|------|--------|--------|
| 73 | 731 | 731TC | SX35 | SX35LT | SX35TC | SX42 | SX42LT | SX42TC |
|----|-----|-------|------|--------|--------|------|--------|--------|

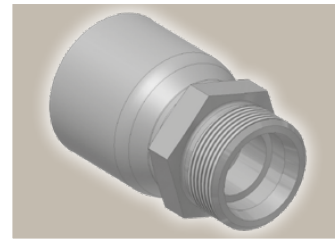
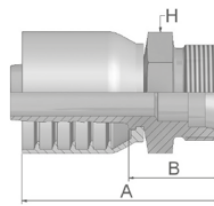

D2 Male Metric 24° – Rigid Heavy Series – Straight

ISO 12151-2-S-S – CES



| Part Number |  Hose I.D. | | | |  Thread metric | Tube O.D. mm | A mm | B mm |  H mm |
|-------------|------------------------------------------------------------------------------------------------|-------|------|------|-------------------------------------------------------------------------------------------------------|--------------------|---------|---------|------------------------------------------------------------------------------------------------|
| | DN | Inch | Size | mm | | | | | |
| 1D273-20-12 | 19 | 3/4 | -12 | 19.1 | M30x2 | 20 | 84 | 35 | 30 |
| 1D273-25-12 | 19 | 3/4 | -12 | 19.1 | M36x2 | 25 | 86 | 38 | 36 |
| 1D273-30-12 | 19 | 3/4 | -12 | 19.1 | M42x2 | 30 | 90 | 42 | 46 |
| 1D273-25-16 | 25 | 1 | -16 | 25.4 | M36x2 | 25 | 91 | 40 | 36 |
| 1D273-30-16 | 25 | 1 | -16 | 25.4 | M42x2 | 30 | 94 | 42 | 46 |
| 1D273-30-20 | 31 | 1 1/4 | -20 | 31.8 | M42x2 | 30 | 110 | 46 | 46 |
| 1D273-38-20 | 31 | 1 1/4 | -20 | 31.8 | M52x2 | 38 | 112 | 46 | 55 |

Approved **fitting series** for hose types:

73 731 731TC SX35 SX35LT SX35TC SX42 SX42LT SX42TC



92 Female BSP Parallel Pipe Swivel – Straight (60° Cone)

BS5200-A – DKR

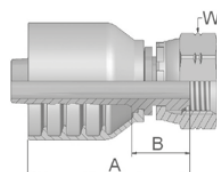

| Part Number | Hose I.D. | | | | Thread BSP | A mm | B mm | W mm |
|-------------|-----------|-------|------|------|---------------|---------|---------|---------|
| | DN | Inch | Size | mm | | | | |
| 19273-12-12 | 19 | 3/4 | -12 | 19.1 | 3/4x14 | 75 | 27 | 32 |
| 19273-16-16 | 25 | 1 | -16 | 25.4 | 1x11 | 89 | 38 | 41 |
| 19273-20-20 | 31 | 1 1/4 | -20 | 31.8 | 1 1/4x11 | 101 | 37 | 50 |
| 19273-24-20 | 31 | 1 1/4 | -20 | 31.8 | 1 1/2x11 | 101 | 37 | 55 |
| 19273-24-24 | 38 | 1 1/2 | -24 | 38.1 | 1 1/2x11 | 100 | 37 | 55 |
| 19273-32-32 | 51 | 2 | -32 | 50.8 | 2x11 | 113 | 38 | 70 |

B1 Female BSP Parallel Pipe Swivel 45° Elbow (60° Cone)

BS 5200-D – DKR 45°

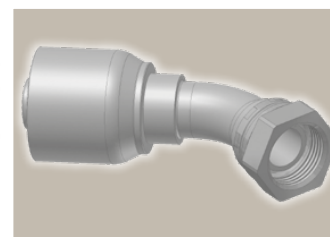
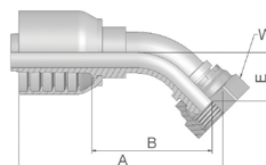

| Part Number | Hose I.D. | | | | Thread BSP | A mm | B mm | E mm | W mm |
|-------------|-----------|-------|------|------|---------------|---------|---------|---------|---------|
| | DN | Inch | Size | mm | | | | | |
| 1B173-12-12 | 19 | 3/4 | -12 | 19.1 | 3/4x14 | 110 | 62 | 26 | 32 |
| 1B173-16-16 | 25 | 1 | -16 | 25.4 | 1x11 | 136 | 84 | 36 | 41 |
| 1B173-20-20 | 31 | 1 1/4 | -20 | 31.8 | 1 1/4x11 | 168 | 104 | 43 | 50 |
| 1B173-24-24 | 38 | 1 1/2 | -24 | 38.1 | 1 1/2x11 | 186 | 123 | 52 | 55 |
| 1B173-32-32 | 51 | 2 | -32 | 50.8 | 2x11 | 249 | 177 | 70 | 70 |

73 Series

Approved **fitting series** for hose types:

73 731 731TC SX35 SX35LT SX35TC SX42 SX42LT SX42TC



Dc-5

Catalogue 4400/UK

B2 Female BSP Parallel Pipe Swivel 90° Elbow (60° Cone)

BS 5200-B – DKR 90°

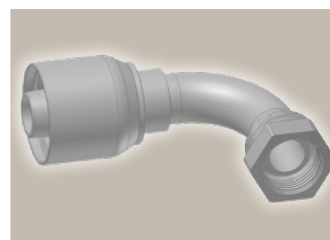
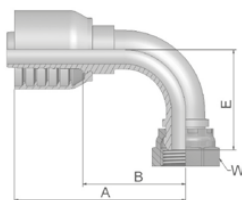

| Part Number | Hose I.D. | | | | Thread BSP | A mm | B mm | E mm | W mm |
|-------------|-----------|-------|------|------|---------------|---------|---------|---------|---------|
| | DN | Inch | Size | mm | | | | | |
| 1B273-12-12 | 19 | 3/4 | -12 | 19.1 | 3/4x14 | 106 | 58 | 55 | 32 |
| 1B273-16-16 | 25 | 1 | -16 | 25.4 | 1x11 | 120 | 70 | 74 | 41 |
| 1B273-20-20 | 31 | 1 1/4 | -20 | 31.8 | 1 1/4x11 | 151 | 87 | 80 | 50 |
| 1B273-24-20 | 31 | 1 1/4 | -20 | 31.8 | 1 1/2x11 | 151 | 87 | 80 | 55 |
| 1B273-24-24 | 38 | 1 1/2 | -24 | 38.1 | 1 1/2x11 | 166 | 103 | 103 | 55 |
| 1B273-32-32 | 51 | 2 | -32 | 50.8 | 2x11 | 229 | 157 | 121 | 70 |

D9 Male BSP Parallel Pipe Rigid – Straight (60° Cone)

BS5200 – AGR

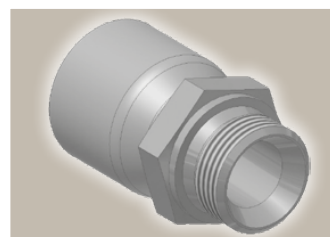
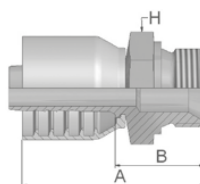

| Part Number | Hose I.D. | | | | Thread BSP | A mm | B mm | H mm |
|-------------|-----------|-------|------|------|---------------|---------|---------|---------|
| | DN | Inch | Size | mm | | | | |
| 1D973-12-12 | 19 | 3/4 | -12 | 19.1 | 3/4x14 | 87 | 39 | 32 |
| 1D973-16-16 | 25 | 1 | -16 | 25.4 | 1x11 | 96 | 43 | 41 |
| 1D973-20-20 | 31 | 1 1/4 | -20 | 31.8 | 1 1/4x11 | 113 | 49 | 50 |
| 1D973-24-24 | 38 | 1 1/2 | -24 | 38.1 | 1 1/2x11 | 114 | 51 | 55 |
| 1D973-32-32 | 51 | 2 | -32 | 50.8 | 2x11 | 129 | 58 | 70 |

Approved **fitting series** for hose types:

73 731 731TC SX35 SX35LT SX35TC SX42 SX42LT SX42TC



01 Male NPTF Pipe Rigid – Straight

SAE J476A / J516 – AGN

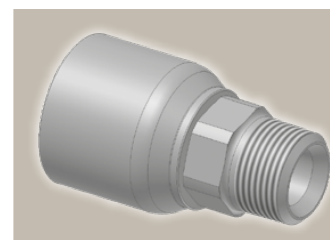
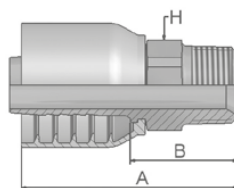

| Part Number | Hose I.D. | | | | Thread NPTF | A mm | B mm | H mm Inch |
|----------------|-----------|-------|------|------|----------------|---------|---------|--------------|
| | DN | Inch | Size | mm | | | | |
| 10173-12-12-SM | 19 | 3/4 | -12 | 19.1 | 3/4-14 | 90 | 42 | 30 |
| 10173-16-12-SM | 19 | 3/4 | -12 | 19.1 | 1-11 1/2 | 96 | 48 | 36 |
| 10173-16-16-SM | 25 | 1 | -16 | 25.4 | 1-11 1/2 | 100 | 50 | 36 |
| 10173-20-20-SM | 31 | 1 1/4 | -20 | 31.8 | 1 1/4-11 1/2 | 125 | 61 | 46 |
| 10173-24-24-SM | 38 | 1 1/2 | -24 | 38.1 | 1 1/2-11 1/2 | 124 | 62 | 50 |
| 10173-32-32 | 51 | 2 | -32 | 50.8 | 2-11 1/2 | 141 | 73 | 2 1/2 |

03 Male JIC 37° – Rigid Straight

ISO12151-5-S – AGJ

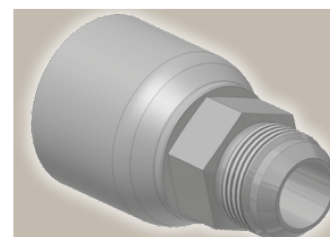
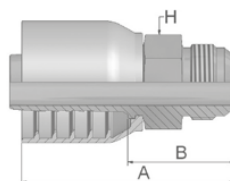

| Part Number | Hose I.D. | | | | Thread UNF | A mm | B mm | H mm |
|----------------|-----------|-------|------|------|---------------|---------|---------|---------|
| | DN | Inch | Size | mm | | | | |
| 10373-12-12-SM | 19 | 3/4 | -12 | 19.1 | 1 1/16x12 | 89 | 41 | 30 |
| 10373-16-12-SM | 19 | 3/4 | -12 | 19.1 | 1 5/16x12 | 93 | 45 | 36 |
| 10373-16-16-SM | 25 | 1 | -16 | 25.4 | 1 5/16x12 | 97 | 47 | 36 |
| 10373-20-16-SM | 25 | 1 | -16 | 25.4 | 1 5/8x12 | 102 | 52 | 46 |
| 10373-20-20-SM | 31 | 1 1/4 | -20 | 31.8 | 1 5/8x12 | 118 | 54 | 46 |
| 10373-24-20-SM | 31 | 1 1/4 | -20 | 31.8 | 1 7/8x12 | 118 | 54 | 50 |
| 10373-24-24-SM | 38 | 1 1/2 | -24 | 38.1 | 1 7/8x12 | 122 | 59 | 50 |
| 10373-32-32-SM | 51 | 2 | -32 | 50.8 | 2 1/2x12 | 143 | 72 | 65 |

73 Series

Approved **fitting series** for hose types:

73 | 731 | 731TC | SX35 | SX35LT | SX35TC | SX42 | SX42LT | SX42TC



Dc-7

Catalogue 4400/UK

06 Female JIC 37° – Swivel Straight

ISO12151-5-SWS – DKJ

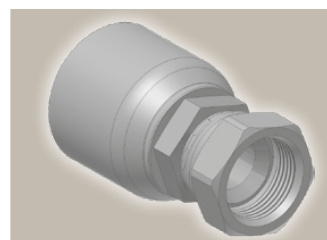
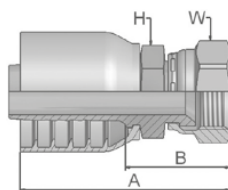

| Part Number | Hose I.D. | | | | Thread UNF | A mm | B mm | H | | W | |
|----------------|-----------|-------|------|------|---------------|---------|---------|----|------|----|------|
| | DN | Inch | Size | mm | | | | mm | Inch | mm | Inch |
| 10673-12-12-SM | 19 | 3/4 | -12 | 19.1 | 1 1/16x12 | 93 | 45 | 30 | | 32 | |
| 10673-16-12 | 19 | 3/4 | -12 | 19.1 | 1 5/16x12 | 99 | 51 | 36 | | 41 | |
| 10673-16-16-SM | 25 | 1 | -16 | 25.4 | 1 5/16x12 | 103 | 52 | 36 | | 41 | |
| 10673-20-16 | 25 | 1 | -16 | 25.4 | 1 5/16x12 | 109 | 59 | 41 | | 50 | |
| 10673-16-20-SM | 31 | 1 1/4 | -20 | 31.8 | 1 5/16x12 | 116 | 52 | 46 | | 41 | |
| 10673-20-20-SM | 31 | 1 1/4 | -20 | 31.8 | 1 5/8x12 | 125 | 61 | 46 | | 50 | |
| 10673-24-20-SM | 31 | 1 1/4 | -20 | 31.8 | 1 7/8x12 | 130 | 66 | 50 | | 60 | |
| 10673-24-24-SM | 38 | 1 1/2 | -24 | 38.1 | 1 7/8x12 | 128 | 66 | 50 | | 60 | |
| 10673-32-24-SM | 38 | 1 1/2 | -24 | 38.1 | 2 1/2x12 | 138 | 76 | 65 | | 75 | |
| 10673-32-32-SM | 51 | 2 | -32 | 50.8 | 2 1/2x12 | 150 | 79 | 65 | | 75 | |

37 Female JIC 37° – Swivel 45° Elbow

ISO 12151-5-SWE 45° – DKJ 45°

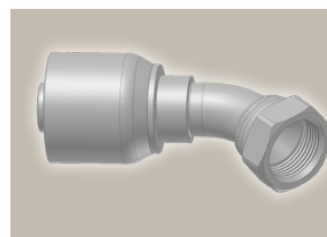
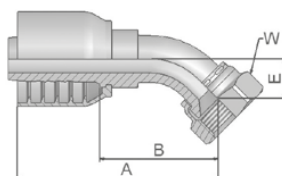

| Part Number | Hose I.D. | | | | Thread UNF | A mm | B mm | E mm | W | |
|----------------|-----------|-------|------|------|---------------|---------|---------|---------|----|----|
| | DN | Inch | Size | mm | | | | | mm | mm |
| 13773-12-12-SM | 19 | 3/4 | -12 | 19.1 | 1 1/16x12 | 104 | 56 | 22 | | 32 |
| 13773-16-12-SM | 19 | 3/4 | -12 | 19.1 | 1 5/16x12 | 107 | 59 | 24 | | 41 |
| 13773-16-16-SM | 25 | 1 | -16 | 25.4 | 1 5/16x12 | 119 | 69 | 24 | | 41 |
| 13773-20-16-SM | 25 | 1 | -16 | 25.4 | 1 5/8x12 | 143 | 92 | 47 | | 55 |
| 13773-20-20-SM | 31 | 1 1/4 | -20 | 31.8 | 1 5/8x12 | 171 | 107 | 47 | | 50 |
| 13773-24-20-SM | 31 | 1 1/4 | -20 | 31.8 | 1 7/8x12 | 172 | 108 | 48 | | 60 |
| 13773-24-24-SM | 38 | 1 1/2 | -24 | 38.1 | 1 7/8x12 | 194 | 132 | 58 | | 60 |
| 13773-32-24-SM | 38 | 1 1/2 | -24 | 38.1 | 2 1/2x12 | 208 | 145 | 72 | | 75 |
| 13773-32-32-SM | 51 | 2 | -32 | 50.8 | 2 1/2x12 | 251 | 179 | 72 | | 75 |

Approved **fitting series** for hose types:

73 | 731 | 731TC | SX35 | SX35LT | SX35TC | SX42 | SX42LT | SX42TC







Dc-8

Catalogue 4400/UK

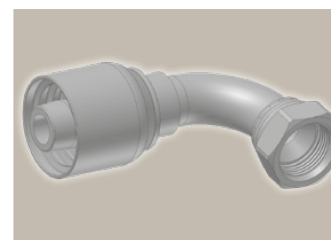
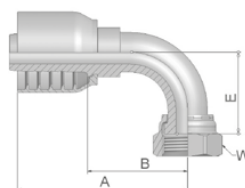
39 Female JIC 37° – Swivel 90° Elbow

ISO 12151-5-SWES – DKJ 90°



| Part Number |  Hose I.D. | | | |  Thread UNF | A mm | B mm | E mm |  W mm |
|----------------|------------------------------------------------------------------------------------------------|-------|------|------|----------------------------------------------------------------------------------------------------|---------|---------|---------|------------------------------------------------------------------------------------------------|
| | DN | Inch | Size | mm | | | | | |
| 13973-12-12-SM | 19 | 3/4 | -12 | 19.1 | 1 1/16x12 | 101 | 53 | 48 | 32 |
| 13973-16-12-SM | 19 | 3/4 | -12 | 19.1 | 1 5/16x12 | 101 | 53 | 56 | 41 |
| 13973-16-16-SM | 25 | 1 | -16 | 25.4 | 1 5/16x12 | 118 | 67 | 56 | 41 |
| 13973-20-16-SM | 25 | 1 | -16 | 25.4 | 1 5/8x12 | 118 | 67 | 85 | 55 |
| 13973-20-20-SM | 31 | 1 1/4 | -20 | 31.8 | 1 5/8x12 | 150 | 87 | 85 | 50 |
| 13973-24-20-SM | 31 | 1 1/4 | -20 | 31.8 | 1 7/8x12 | 151 | 87 | 102 | 60 |
| 13973-24-24-SM | 38 | 1 1/2 | -24 | 38.1 | 1 7/8x12 | 194 | 119 | 102 | 60 |
| 13973-32-24-SM | 38 | 1 1/2 | -24 | 38.1 | 2 1/2x12 | 168 | 106 | 152 | 75 |
| 13973-32-32-SM | 51 | 2 | -32 | 50.8 | 2 1/2x12 | 229 | 157 | 152 | 75 |

73 Series

Approved **fitting series** for hose types:

73 731 731TC SX35 SX35LT SX35TC SX42 SX42LT SX42TC



15/4A ISO 6162-1-Flange Straight

ISO 12151-3-S-L – SFL
(35.0 MPa/ 5000 psi)

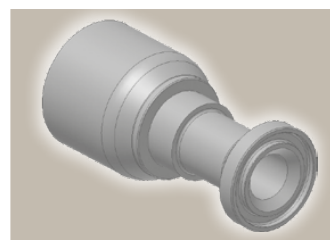
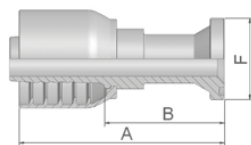

| Part Number | Hose I.D. | | | | Flange Inch | A mm | B mm | F mm |
|-------------|-----------|-------|------|------|----------------|---------|---------|---------|
| | DN | Inch | Size | mm | | | | |
| 11573-12-12 | 19 | 3/4 | -12 | 19.1 | 3/4 | 110 | 62 | 38 |
| 11573-16-12 | 19 | 3/4 | -12 | 19.1 | 1 | 110 | 62 | 45 |
| 11573-12-16 | 25 | 1 | -16 | 25.4 | 3/4 | 117 | 67 | 38 |
| 11573-16-16 | 25 | 1 | -16 | 25.4 | 1 | 117 | 67 | 45 |
| 14A73-20-16 | 25 | 1 | -16 | 25.4 | 1 1/4 | 85 | 34 | 51 |
| 11573-16-20 | 31 | 1 1/4 | -20 | 31.8 | 1 | 133 | 69 | 45 |
| 14A73-20-20 | 31 | 1 1/4 | -20 | 31.8 | 1 1/4 | 141 | 77 | 51 |
| 14A73-24-20 | 31 | 1 1/4 | -20 | 31.8 | 1 1/2 | 104 | 40 | 60 |
| 14A73-20-24 | 38 | 1 1/2 | -24 | 38.1 | 1 1/4 | 142 | 80 | 51 |
| 14A73-24-24 | 38 | 1 1/2 | -24 | 38.1 | 1 1/2 | 166 | 103 | 60 |
| 14A73-32-24 | 38 | 1 1/2 | -24 | 38.1 | 2 | 113 | 50 | 71 |
| 14A73-24-32 | 51 | 2 | -32 | 50.8 | 1 1/2 | 156 | 84 | 60 |
| 14A73-32-32 | 51 | 2 | -32 | 50.8 | 2 | 220 | 148 | 71 |

SAE flange halves see in section Eb.

Fittings with standard O-ring seals can be used for temperatures from -40 °C up to +105 °C.

O-rings see section Eb. Special O-rings are available on request.

17/4F ISO 6162-1-Flange 45° Elbow

ISO 12151-3 – E45S – L – SFL 45°
(35.0 MPa/ 5000 psi)

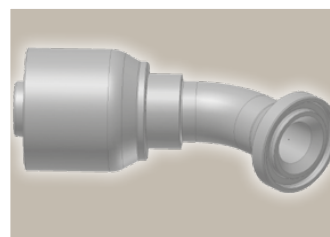
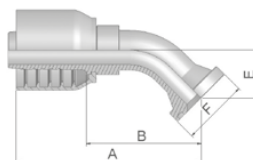

| Part Number | Hose I.D. | | | | Flange Inch | A mm | B mm | E mm | F mm |
|-------------|-----------|-------|------|------|----------------|---------|---------|---------|---------|
| | DN | Inch | Size | mm | | | | | |
| 11773-12-12 | 19 | 3/4 | -12 | 19.1 | 3/4 | 119 | 71 | 27 | 38 |
| 11773-16-12 | 19 | 3/4 | -12 | 19.1 | 1 | 109 | 64 | 26 | 44 |
| 11773-12-16 | 25 | 1 | -16 | 25.4 | 3/4 | 130 | 80 | 32 | 38 |
| 11773-16-16 | 25 | 1 | -16 | 25.4 | 1 | 127 | 77 | 32 | 45 |
| 14F73-20-16 | 25 | 1 | -16 | 25.4 | 1 1/4 | 136 | 85 | 32 | 51 |
| 14F73-20-20 | 31 | 1 1/4 | -20 | 31.8 | 1 1/4 | 160 | 96 | 35 | 51 |
| 14F73-24-20 | 31 | 1 1/4 | -20 | 31.8 | 1 1/2 | 162 | 102 | 38 | 60 |
| 14F73-24-24 | 38 | 1 1/2 | -24 | 38.1 | 1 1/2 | 178 | 115 | 44 | 60 |
| 14F73-32-24 | 38 | 1 1/2 | -24 | 38.1 | 2 | 177 | 114 | 43 | 71 |
| 14F73-24-32 | 51 | 2 | -32 | 50.8 | 1 1/2 | 192 | 120 | 53 | 60 |
| 14F73-32-32 | 51 | 2 | -32 | 50.8 | 2 | 224 | 153 | 62 | 71 |

SAE flange halves see in section Eb.

Fittings with standard O-ring seals can be used for temperatures from -40 °C up to +105 °C.

O-rings see section Eb. Special O-rings are available on request.

Approved **fitting series** for hose types:

73 731 731TC SX35 SX35LT SX35TC SX42 SX42LT SX42TC

19/4N ISO 6162-1-Flange 90° Elbow

ISO 12151-3-E-L – SFL 90°
(35.0 MPa/ 5000 psi)

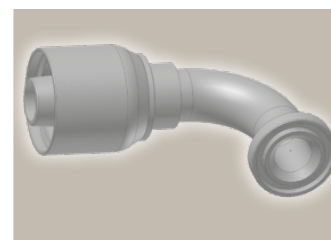
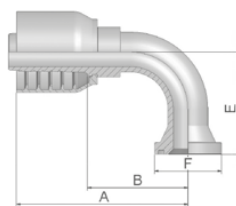

| Part Number | Hose I.D. | | | | Flange Inch | A mm | B mm | E mm | F mm |
|-------------|-----------|-------|------|------|----------------|---------|---------|---------|---------|
| | DN | Inch | Size | mm | | | | | |
| 11973-12-12 | 19 | 3/4 | -12 | 19.1 | 3/4 | 109 | 61 | 58 | 38 |
| 11973-16-12 | 19 | 3/4 | -12 | 19.1 | 1 | 102 | 54 | 58 | 45 |
| 11973-12-16 | 25 | 1 | -16 | 25.4 | 3/4 | 121 | 70 | 70 | 38 |
| 11973-16-16 | 25 | 1 | -16 | 25.4 | 1 | 118 | 67 | 70 | 45 |
| 14N73-20-16 | 25 | 1 | -16 | 25.4 | 1 1/4 | 128 | 78 | 68 | 51 |
| 14N73-24-16 | 25 | 1 | -16 | 25.4 | 1 1/2 | 132 | 81 | 70 | 60 |
| 11973-16-20 | 31 | 1 1/4 | -20 | 31.8 | 1 | 133 | 69 | 70 | 44 |
| 14N73-20-20 | 31 | 1 1/4 | -20 | 31.8 | 1 1/4 | 155 | 91 | 90 | 51 |
| 14N73-24-20 | 31 | 1 1/4 | -20 | 31.8 | 1 1/2 | 155 | 91 | 90 | 60 |
| 14N73-24-24 | 38 | 1 1/2 | -24 | 38.1 | 1 1/2 | 166 | 103 | 93 | 60 |
| 14N73-32-24 | 38 | 1 1/2 | -24 | 38.1 | 2 | 166 | 103 | 92 | 71 |
| 14N73-32-32 | 51 | 2 | -32 | 50.8 | 2 | 220 | 148 | 133 | 71 |

SAE flange halves see in section Eb.

Fittings with standard O-ring seals can be used for temperatures from -40 °C up to +105 °C.
O-rings see section Eb. Special O-rings are available on request.

6A ISO 6162-2-Flange Straight

ISO 12151-3-S-S – SFS
(42.0 MPa/ 6000 psi)

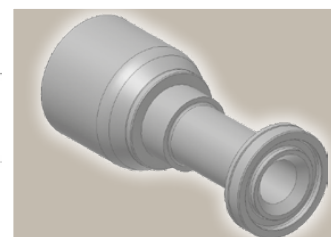
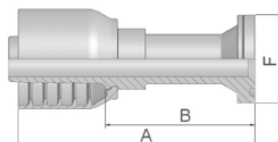

| Part Number | Hose I.D. | | | | Flange Inch | A mm | B mm | F mm |
|-------------|-----------|-------|------|------|----------------|---------|---------|---------|
| | DN | Inch | Size | mm | | | | |
| 16A73-8-12 | 19 | 3/4 | -12 | 19.1 | 1/2 | 123 | 75 | 32 |
| 16A73-12-12 | 19 | 3/4 | -12 | 19.1 | 3/4 | 130 | 82 | 41 |
| 16A73-16-12 | 19 | 3/4 | -12 | 19.1 | 1 | 135 | 87 | 48 |
| 16A73-20-12 | 19 | 3/4 | -12 | 19.1 | 1 1/4 | 96 | 48 | 54 |
| 16A73-12-16 | 25 | 1 | -16 | 25.4 | 3/4 | 124 | 73 | 41 |
| 16A73-16-16 | 25 | 1 | -16 | 25.4 | 1 | 131 | 81 | 48 |
| 16A73-20-16 | 25 | 1 | -16 | 25.4 | 1 1/4 | 142 | 91 | 54 |
| 16A73-16-20 | 31 | 1 1/4 | -20 | 31.8 | 1 | 147 | 83 | 48 |
| 16A73-20-20 | 31 | 1 1/4 | -20 | 31.8 | 1 1/4 | 149 | 85 | 54 |
| 16A73-24-20 | 31 | 1 1/4 | -20 | 31.8 | 1 1/2 | 121 | 57 | 64 |
| 16A73-20-24 | 38 | 1 1/2 | -24 | 38.1 | 1 1/4 | 158 | 96 | 54 |
| 16A73-24-24 | 38 | 1 1/2 | -24 | 38.1 | 1 1/2 | 166 | 104 | 64 |
| 16A73-32-24 | 38 | 1 1/2 | -24 | 38.1 | 2 | 129 | 66 | 79 |
| 16A73-32-32 | 51 | 2 | -32 | 50.8 | 2 | 194 | 122 | 79 |

SAE flange halves see in section Eb.

Fittings with standard O-ring seals can be used for temperatures from -40 °C up to +105 °C.
O-rings see section Eb. Special O-rings are available on request.

Approved **fitting series** for hose types:

73 731 731TC SX35 SX35LT SX35TC SX42 SX42LT SX42TC

73 Series

6E ISO 6162-2 Flange 30° Elbow

SFS 30°
(42.0 MPa/ 6000 psi)

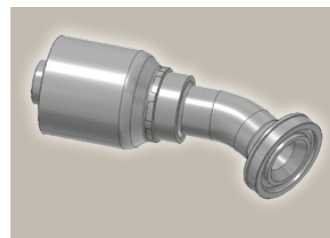
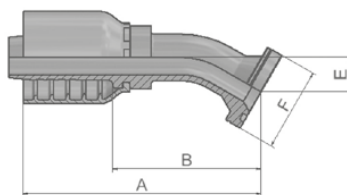

| Part Number | Hose I.D. | | | | Flange Inch | A mm | B mm | E mm | F mm |
|-------------|-----------|------|------|------|----------------|---------|---------|---------|---------|
| | DN | Inch | Size | mm | | | | | |
| 16E73-12-12 | 19 | 3/4 | -12 | 19.1 | - | - | - | - | - |
| 16E73-12-16 | 25 | 1 | -16 | 25.4 | - | - | - | - | - |
| 16E73-16-16 | 25 | 1 | -16 | 25.4 | - | - | - | - | - |

SAE flange halves see in section Eb.

Fittings with standard O-ring seals can be used for temperatures from -40 °C up to +105 °C.
O-rings see section Eb. Special O-rings are available on request.

6F ISO 6162-2-Flange 45° Elbow – Heavy Series

ISO 12151-3 – E45-S – SFS 45°
(42.0 MPa/ 6000 psi)

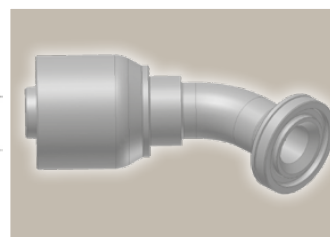
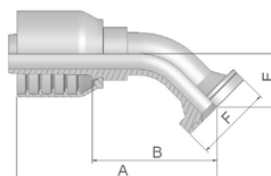

| Part Number | Hose I.D. | | | | Flange Inch | A mm | B mm | E mm | F mm |
|-------------|-----------|-------|------|------|----------------|---------|---------|---------|---------|
| | DN | Inch | Size | mm | | | | | |
| 16F73-8-12 | 19 | 3/4 | -12 | 19.1 | 1/2 | 107 | 59 | 27 | 32 |
| 16F73-12-12 | 19 | 3/4 | -12 | 19.1 | 3/4 | 110 | 62 | 26 | 41 |
| 16F73-16-12 | 19 | 3/4 | -12 | 19.1 | 1 | 110 | 62 | 26 | 48 |
| 16F73-20-12 | 19 | 3/4 | -12 | 19.1 | 1 1/4 | 125 | 77 | 32 | 54 |
| 16F73-12-16 | 25 | 1 | -16 | 25.4 | 3/4 | 123 | 73 | 32 | 41 |
| 16F73-16-16 | 25 | 1 | -16 | 25.4 | 1 | 129 | 79 | 32 | 48 |
| 16F73-20-16 | 25 | 1 | -16 | 25.4 | 1 1/4 | 129 | 79 | 32 | 54 |
| 16F73-16-20 | 31 | 1 1/4 | -20 | 31.8 | 1 | 157 | 93 | 33 | 48 |
| 16F73-20-20 | 31 | 1 1/4 | -20 | 31.8 | 1 1/4 | 163 | 98 | 38 | 54 |
| 16F73-24-20 | 31 | 1 1/4 | -20 | 31.8 | 1 1/2 | 163 | 99 | 38 | 63 |
| 16F73-20-24 | 38 | 1 1/2 | -24 | 38.1 | 1 1/4 | 170 | 107 | 44 | 54 |
| 16F73-24-24 | 38 | 1 1/2 | -24 | 38.1 | 1 1/2 | 178 | 115 | 44 | 64 |
| 16F73-32-32 | 51 | 2 | -32 | 50.8 | 2 | 230 | 158 | 56 | 79 |

SAE flange halves see in section Eb.

Fittings with standard O-ring seals can be used for temperatures from -40 °C up to +105 °C.
O-rings see section Eb. Special O-rings are available on request.

Approved **fitting series** for hose types:

73 | 731 | 731TC | SX35 | SX35LT | SX35TC | SX42 | SX42LT | SX42TC



6N ISO 6162-2-Flange 90° Elbow

ISO 12151-3 – E-S – SFS 90°
(42.0 MPa/ 6000 psi)

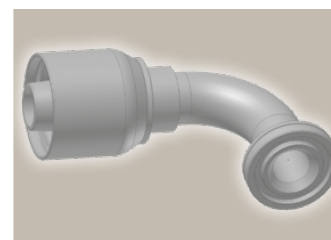
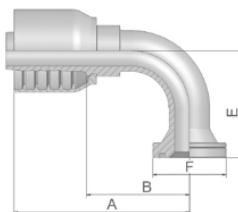

| Part Number | Hose I.D. | | | | Flange Inch | A mm | B mm | E mm | F mm |
|-------------|-----------|-------|------|------|----------------|---------|---------|---------|---------|
| | DN | Inch | Size | mm | | | | | |
| 16N73-8-12 | 19 | 3/4 | -12 | 19.1 | 1/2 | 92 | 44 | 58 | 32 |
| 16N73-12-12 | 19 | 3/4 | -12 | 19.1 | 3/4 | 101 | 53 | 58 | 41 |
| 16N73-16-12 | 19 | 3/4 | -12 | 19.1 | 1 | 111 | 63 | 58 | 48 |
| 16N73-20-12 | 19 | 3/4 | -12 | 19.1 | 1 1/4 | 110 | 62 | 63 | 54 |
| 16N73-12-16 | 25 | 1 | -16 | 25.4 | 3/4 | 109 | 58 | 70 | 41 |
| 16N73-16-16 | 25 | 1 | -16 | 25.4 | 1 | 122 | 71 | 70 | 48 |
| 16N73-20-16 | 25 | 1 | -16 | 25.4 | 1 1/4 | 122 | 71 | 70 | 54 |
| 16N73-16-20 | 31 | 1 1/4 | -20 | 31.8 | 1 | 137 | 73 | 90 | 48 |
| 16N73-20-20 | 31 | 1 1/4 | -20 | 31.8 | 1 1/4 | 172 | 108 | 71 | 54 |
| 16N73-24-20 | 31 | 1 1/4 | -20 | 31.8 | 1 1/2 | 172 | 108 | 76 | 64 |
| 16N73-20-24 | 38 | 1 1/2 | -24 | 38.1 | 1 1/4 | 152 | 90 | 104 | 54 |
| 16N73-24-24 | 38 | 1 1/2 | -24 | 38.1 | 1 1/2 | 166 | 103 | 104 | 64 |
| 16N73-32-24 | 38 | 1 1/2 | -24 | 38.1 | 2 | 166 | 103 | 104 | 79 |
| 16N73-24-32 | 51 | 2 | -32 | 50.8 | 1 1/2 | 188 | 116 | 104 | 64 |
| 16N73-32-32 | 51 | 2 | -32 | 50.8 | 2 | 229 | 157 | 138 | 79 |

SAE flange halves see in section Eb.

Fittings with standard O-ring seals can be used for temperatures from -40 °C up to +105 °C.
O-rings see section Eb. Special O-rings are available on request.

XA Caterpillar® Flange Straight

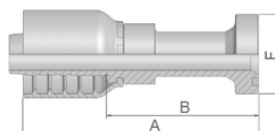

| Part Number | Hose I.D. | | | | Flange Inch | A mm | B mm | F mm |
|-------------|-----------|-------|------|------|----------------|---------|---------|---------|
| | DN | Inch | Size | mm | | | | |
| 1XA73-12-12 | 19 | 3/4 | -12 | 19.1 | 3/4 | 123 | 75 | 41 |
| 1XA73-16-12 | 19 | 3/4 | -12 | 19.1 | 1 | 134 | 86 | 48 |
| 1XA73-16-16 | 25 | 1 | -16 | 25.4 | 1 | 138 | 88 | 48 |
| 1XA73-20-16 | 25 | 1 | -16 | 25.4 | 1 1/4 | 144 | 93 | 54 |
| 1XA73-20-20 | 31 | 1 1/4 | -20 | 31.8 | 1 1/4 | 155 | 96 | 54 |
| 1XA73-24-20 | 31 | 1 1/4 | -20 | 31.8 | 1 1/2 | 162 | 97 | 64 |

Fittings with standard O-ring seals can be used for temperatures from -40 °C up to +105 °C.
O-rings see section Eb. Special O-rings are available on request.

73 Series

Approved **fitting series** for hose types:

73 731 731TC SX35 SX35LT SX35TC SX42 SX42LT SX42TC

XF Caterpillar® Flange 45° Elbow

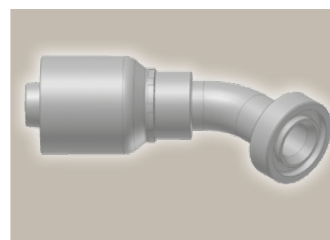
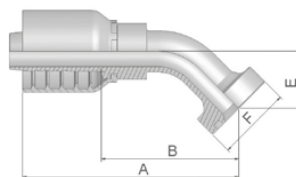

| Part Number | Hose I.D. | | | | Flange Inch | A mm | B mm | E mm | F mm |
|-------------|-----------|-------|------|------|----------------|---------|---------|---------|---------|
| | DN | Inch | Size | mm | | | | | |
| 1XF73-12-12 | 19 | 3/4 | -12 | 19.1 | 3/4 | 123 | 75 | 31 | 41 |
| 1XF73-16-12 | 19 | 3/4 | -12 | 19.1 | 1 | 122 | 74 | 31 | 48 |
| 1XF73-16-16 | 25 | 1 | -16 | 25.4 | 1 | 139 | 88 | 36 | 48 |
| 1XF73-20-20 | 31 | 1 1/4 | -20 | 31.8 | 1 1/4 | 162 | 98 | 37 | 54 |
| 1XF73-24-20 | 31 | 1 1/4 | -20 | 31.8 | 1 1/2 | 182 | 117 | 36 | 64 |

Fittings with standard O-ring seals can be used for temperatures from -40 °C up to +105 °C.
O-rings see section Eb. Special O-rings are available on request.

XG Caterpillar® Flange 60° Elbow

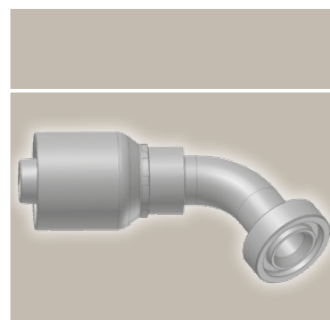
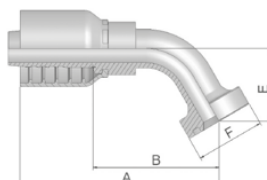

| Part Number | Hose I.D. | | | | Flange Inch | A mm | B mm | E mm | F mm |
|-------------|-----------|------|------|------|----------------|---------|---------|---------|---------|
| | DN | Inch | Size | mm | | | | | |
| 1XG73-12-12 | 19 | 3/4 | -12 | 19.1 | 3/4 | 41 | 138 | 90 | 42 |
| 1XG73-16-16 | 25 | 1 | -16 | 25.4 | 1 | 48 | 160 | 109 | 50 |
| 1XG73-20-16 | 25 | 1 | -16 | 25.4 | 1 1/4 | 54 | 153 | 103 | 48 |

Fittings with standard O-ring seals can be used for temperatures from -40 °C up to +105 °C.
O-rings see section Eb. Special O-rings are available on request.

Approved **fitting series** for hose types:

73 731 731TC SX35 SX35LT SX35TC SX42 SX42LT SX42TC

XN Caterpillar® Flange
90° Elbow

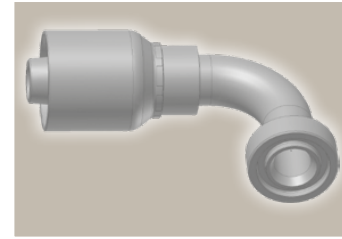
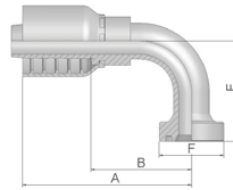

| Part Number | Hose I.D. | | | | Flange | A mm | B mm | E mm | F mm |
|-------------|---------------|-------|------|------|------------|---------|---------|---------|---------|
| | DN | Inch | Size | mm | | | | | |
| 1XN73-12-12 | 19 | 3/4 | -12 | 19.1 | 3/4 | 111 | 63 | 63 | 41 |
| 1XN73-16-12 | 19 | 3/4 | -12 | 19.1 | 1 | 111 | 63 | 62 | 48 |
| 1XN73-16-16 | 25 | 1 | -16 | 25.4 | 1 | 128 | 78 | 74 | 48 |
| 1XN73-20-16 | 25 | 1 | -16 | 25.4 | 1 1/4 | 122 | 71 | 74 | 54 |
| 1XN73-20-20 | 31 | 1 1/4 | -20 | 31.8 | 1 1/4 | 172 | 108 | 77 | 54 |

Fittings with standard O-ring seals can be used for temperatures from -40 °C up to +105 °C.
O-rings see section Eb. Special O-rings are available on request.

73 Series

Approved **fitting series** for hose types:

73 | 731 | 731TC | SX35 | SX35LT | SX35TC | SX42 | SX42LT | SX42TC



JC Female ORFS Swivel – Straight Short

ISO 12151-1 – SWSA
SAE J516 – ORFS

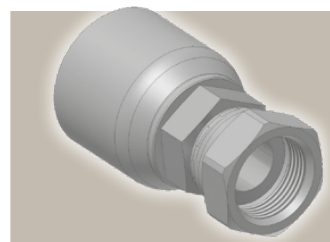
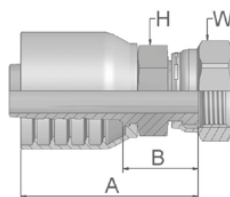

| Part Number | Hose I.D. | | | | Thread UNF | A mm | B mm | H mm | W mm |
|----------------|-----------|-------|------|------|---------------|---------|---------|---------|---------|
| | DN | Inch | Size | mm | | | | | |
| 1JC73-12-12-SM | 19 | 3/4 | -12 | 19.1 | 1 3/16x12 | 81 | 33 | 30 | 36 |
| 1JC73-16-16-SM | 25 | 1 | -16 | 25.4 | 1 7/16x12 | 89 | 38 | 36 | 41 |
| 1JC73-20-20-SM | 31 | 1 1/4 | -20 | 31.8 | 1 11/16x12 | 106 | 42 | 46 | 50 |
| 1JC73-24-24-SM | 38 | 1 1/2 | -24 | 38.1 | 2x12 | 117 | 44 | 50 | 60 |

JS ORFS Swivel Female (Long)

ISO 12151-1-SWSB
SAE J516 – ORFS

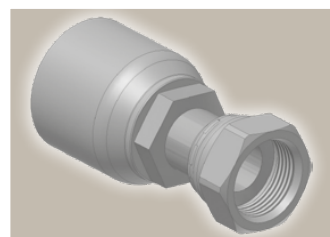
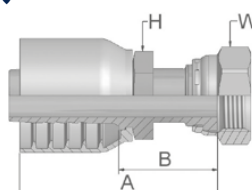

| Part Number | Hose I.D. | | | | Thread UNF | A mm | B mm | H mm Inch | W mm Inch |
|----------------|-----------|-------|------|------|---------------|---------|---------|--------------|--------------|
| | DN | Inch | Size | mm | | | | | |
| 1JS73-12-12-SM | 19 | 3/4 | -12 | 19.1 | 1 3/16x12 | 94 | 46 | 30 | 36 |
| 1JS73-16-12-SM | 19 | 3/4 | -12 | 19.1 | 1 7/16x12 | 107 | 58 | 36 | 41 |
| 1JS73-16-16-SM | 25 | 1 | -16 | 25.4 | 1 7/16x12 | 103 | 52 | 36 | 41 |
| 1JS73-20-16-SM | 25 | 1 | -16 | 25.4 | 1 11/16x12 | 114 | 64 | 41 | 50 |
| 1JS73-20-20-SM | 31 | 1 1/4 | -20 | 31.8 | 1 11/16x12 | 117 | 54 | 46 | 50 |
| 1JS73-24-24-SM | 38 | 1 1/2 | -24 | 38.1 | 2x12 | 120 | 57 | 50 | 60 |

Approved **fitting series** for hose types:

73 731 731TC SX35 SX35LT SX35TC SX42 SX42LT SX42TC



J7 Female ORFS – Swivel 45° Elbow

ISO 12151-1 – SWE 45°
SAE J516 – ORFS 45°

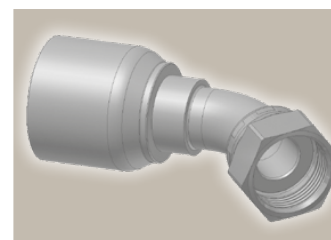
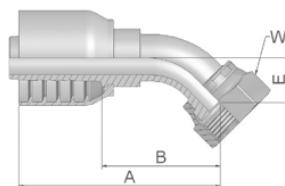

| Part Number | Hose I.D. | | | | Thread UNF | A mm | B mm | E mm | W mm |
|----------------|-----------|-------|------|------|---------------|---------|---------|---------|---------|
| | DN | Inch | Size | mm | | | | | |
| 1J773-12-12-SM | 19 | 3/4 | -12 | 19.1 | 1 3/16x12 | 105 | 57 | 21 | 36 |
| 1J773-16-12-SM | 19 | 3/4 | -12 | 19.1 | 1 7/16x12 | 107 | 59 | 24 | 41 |
| 1J773-16-16-SM | 25 | 1 | -16 | 25.4 | 1 7/16x12 | 119 | 69 | 24 | 41 |
| 1J773-20-16-SM | 25 | 1 | -16 | 25.4 | 1 11/16x12 | 131 | 80 | 26 | 50 |
| 1J773-20-20 | 31 | 1 1/4 | -20 | 31.8 | 1 11/16x12 | 147 | 83 | 25 | 7/8 |
| 1J773-20-20-SM | 31 | 1 1/4 | -20 | 31.8 | 1 11/16x12 | 154 | 90 | 30 | 50 |
| 1J773-24-20-SM | 31 | 1 1/4 | -20 | 31.8 | 2x12 | 164 | 100 | 40 | 60 |

J9 Female ORFS – Swivel 90° Elbow – Short Drop

ISO 12151-1 – SWES
SAE J516 – ORFS 90°

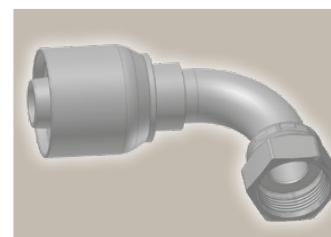
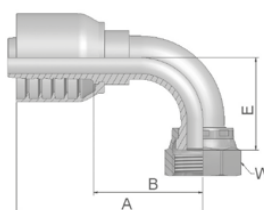

| Part Number | Hose I.D. | | | | Thread UNF | A mm | B mm | E mm | W | |
|----------------|-----------|-------|------|------|---------------|---------|---------|---------|-----|------|
| | DN | Inch | Size | mm | | | | | mm | Inch |
| 1J973-12-12-SM | 19 | 3/4 | -12 | 19.1 | 1 3/16x12 | 101 | 53 | 48 | 36 | |
| 1J973-16-12-SM | 19 | 3/4 | -12 | 19.1 | 1 7/16x12 | 113 | 65 | 56 | 41 | |
| 1J973-16-16-SM | 25 | 1 | -16 | 25.4 | 1 7/16x12 | 120 | 70 | 56 | 41 | |
| 1J973-20-16-SM | 25 | 1 | -16 | 25.4 | 1 11/16x12 | 127 | 77 | 64 | 50 | |
| 1J973-20-20 | 31 | 1 1/4 | -20 | 31.8 | 1-11/16x12 | 148 | 84 | 64 | 7/8 | |
| 1J973-24-24-SM | 38 | 1 1/2 | -24 | 38.1 | 2x12 | 166 | 103 | 82 | 60 | |

73 Series

Approved **fitting series** for hose types:

73 | 731 | 731TC | SX35 | SX35LT | SX35TC | SX42 | SX42LT | SX42TC





JM

ORFS Male

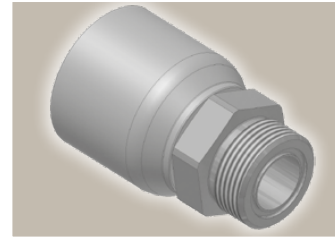
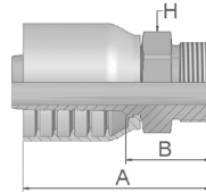
ISO 12151-1-S – SAE J516



| Part Number |  Hose I.D. | | | |  Thread UNF | A mm | B mm |  H mm |
|----------------|------------------------------------------------------------------------------------------------|-------|------|------|----------------------------------------------------------------------------------------------------|---------|---------|------------------------------------------------------------------------------------------------|
| | DN | Inch | Size | mm | | | | |
| 1JM73-12-12-SM | 19 | 3/4 | -12 | 19.1 | 1 3/16x12 | 86 | 38 | 32 |
| 1JM73-16-12-SM | 19 | 3/4 | -12 | 19.1 | 1 7/16x12 | 87 | 39 | 41 |
| 1JM73-16-16-SM | 25 | 1 | -16 | 25.4 | 1 7/16x12 | 93 | 42 | 41 |
| 1JM73-20-16-SM | 25 | 1 | -16 | 25.4 | 1 11/16x12 | 89 | 39 | 46 |
| 1JM73-20-20-SM | 31 | 1 1/4 | -20 | 31.8 | 1 11/16x12 | 106 | 42 | 46 |

JM fittings are supplied without O-ring.
O-rings see section Eb. Special O-rings are available on request.

Approved **fitting series** for hose types:





73 | 731 | 731TC | SX35 | SX35LT | SX35TC | SX42 | SX42LT | SX42TC

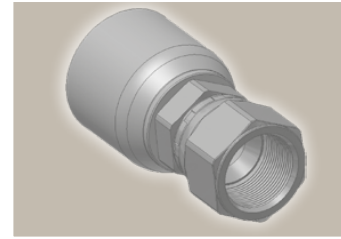
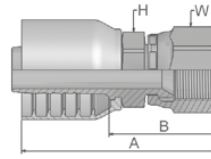

XU Female Metric – Swivel Straight (30° Flare)

JIS B8363



| Part Number |  Hose I.D. | | | |  Thread metric | A mm | B mm |  H mm |  W mm |
|-------------|------------------------------------------------------------------------------------------------|------|------|------|-------------------------------------------------------------------------------------------------------|---------|---------|------------------------------------------------------------------------------------------------|------------------------------------------------------------------------------------------------|
| | DN | Inch | Size | mm | | | | | |
| 1XU73-12-12 | 19 | 3/4 | -12 | 19.1 | M30x1.5 | 76 | 28 | 32 | 36 |
| 1XU73-16-16 | 25 | 1 | -16 | 25.4 | M33x1.5 | 85 | 35 | 36 | 41 |

73 Series

Approved **fitting series** for hose types:

- 73 | 731 | 731TC | SX35 | SX35LT | SX35TC | SX42 | SX42LT | SX42TC



Large range of special hose fittings for the MRO market

The demand for special hose fittings is part of our everyday business. In order to meet this demand with the authority expected, the Polymer Hose Division Europe has extended its standard offer with special hose fittings such as an extra drop length, etc.

The following is an overview of our special hose fitting selection:

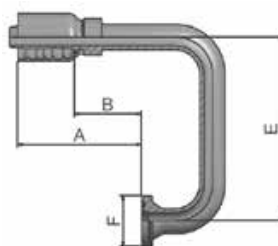

Further special hose fittings are available on request.

| Part Number | Description | | | A mm | B mm | E mm | F mm |
|-------------------|---------------------------------------------|-------------------|----------------|---------|---------|---------|---------|
| | | Hose I.D. Size | Flange Inch | | | | |
| 11973-12-12-SL100 | SAE 5000 psi 90° elbow - drop length 100 mm | -12 | 3/4 | 109 | 61 | 100 | 38 |
| 11973-12-12-SL150 | SAE 5000 psi 90° elbow - drop length 150 mm | -12 | 3/4 | 109 | 61 | 150 | 38 |
| 11973-12-12-SL180 | SAE 5000 psi 90° elbow - drop length 180 mm | -12 | 3/4 | 109 | 61 | 180 | 38 |
| 11973-16-16-SL100 | SAE 5000 psi 90° elbow - drop length 100 mm | -16 | 1 | 118 | 67 | 100 | 45 |
| 11973-16-16-SL150 | SAE 5000 psi 90° elbow - drop length 150 mm | -16 | 1 | 118 | 67 | 150 | 45 |
| 11973-16-16-SL90 | SAE 5000 psi 90° elbow - drop length 90 mm | -16 | 1 | 118 | 67 | 90 | 45 |
| 14N73-20-20-SL150 | SAE 5000 psi 90° elbow - drop length 150 mm | -20 | 1 1/4 | 155 | 91 | 150 | 51 |
| 16N73-12-12-SL100 | SAE 6000 psi 90° elbow - drop length 100 mm | -12 | 3/4 | 101 | 53 | 100 | 41 |
| 16N73-12-12-SL140 | SAE 6000 psi 90° elbow - drop length 140 mm | -12 | 3/4 | 101 | 53 | 140 | 41 |
| 16N73-12-12-SL150 | SAE 6000 psi 90° elbow - drop length 150 mm | -12 | 3/4 | 101 | 53 | 150 | 41 |
| 16N73-12-12-SL85 | SAE 6000 psi 90° elbow - drop length 85 mm | -12 | 3/4 | 101 | 53 | 85 | 41 |
| 16N73-16-12-SL100 | SAE 6000 psi 90° elbow - drop length 100 mm | -12 | 1 | 111 | 63 | 100 | 48 |
| 16N73-16-12-SL116 | SAE 6000 psi 90° elbow - drop length 116 mm | -12 | 1 | 111 | 63 | 116 | 48 |
| 16N73-16-12-SL120 | SAE 6000 psi 90° elbow - drop length 120 mm | -12 | 1 | 111 | 63 | 120 | 48 |
| 16N73-16-16-SL100 | SAE 6000 psi 90° elbow - drop length 100 mm | -16 | 1 | 118 | 67 | 100 | 48 |
| 16N73-16-16-SL110 | SAE 6000 psi 90° elbow - drop length 110 mm | -16 | 1 | 122 | 71 | 110 | 48 |
| 16N73-16-16-SL116 | SAE 6000 psi 90° elbow - drop length 116 mm | -16 | 1 | 128 | 77 | 116 | 48 |
| 16N73-16-16-SL125 | SAE 6000 psi 90° elbow - drop length 125 mm | -16 | 1 | 118 | 67 | 125 | 48 |
| 16N73-16-16-SL140 | SAE 6000 psi 90° elbow - drop length 140 mm | -16 | 1 | 122 | 71 | 140 | 48 |
| 16N73-16-16-SL175 | SAE 6000 psi 90° elbow - drop length 175 mm | -16 | 1 | 122 | 71 | 175 | 48 |
| 16N73-16-16SL150 | SAE 6000 psi 90° elbow - drop length 150 mm | -16 | 1 | 117 | 67 | 150 | 48 |
| 16N73-20-16-SL120 | SAE 6000 psi 90° elbow - drop length 120 mm | -16 | 1 1/4 | 122 | 71 | 120 | 54 |
| 16N73-20-16-SL160 | SAE 6000 psi 90° elbow - drop length 160 mm | -16 | 1 1/4 | 122 | 71 | 160 | 54 |
| 16N73-20-20-SL100 | SAE 6000 psi 90° elbow - drop length 100 mm | -20 | 1 1/4 | 155 | 91 | 100 | 54 |
| 16N73-20-20-SL180 | SAE 6000 psi 90° elbow - drop length 180 mm | -20 | 1 1/4 | 155 | 91 | 180 | 54 |
| 16N73-20-20SL145 | SAE 6000 psi 90° elbow - drop length 145 mm | -20 | 1 1/4 | 155 | 91 | 145 | 54 |
| 16N73-24-24-SL90 | SAE 6000 psi 90° elbow - drop length 90 mm | -24 | 1 1/2 | 166 | 103 | 90 | 64 |









Approved **fitting series** for hose types:

73 | 731 | 731TC | SX35 | SX35LT | SX35TC | SX42 | SX42LT | SX42TC





DIN – Metric

Page Dd-1 – Dd-4

| | | | |
|------------------------------------------------------------------------------------------------------------------------------------------------------------------------------------------------------------------------|-------------------------------------------------------------------------------------------------------------------------------------------------------------------------------------------------------------------------------|------------------------------------------------------------------------------------------------------------------------------------------------------------------------------------------------------------------------------|----------------------------------------------------------------------------------------------------------------------------------------------------------------------------------------------------------|
| <p>CA</p> <p>Dd-1</p>  <p>Female Metric 24° Light Series with O-Ring Swivel – Straight ISO 12151-2-SWS-L – DKOL</p> | <p>CE</p> <p>Dd-1</p>  <p>Female Metric 24° Light Series with O-Ring Swivel – 45° Elbow ISO 12151-2-SWE-L – DKOL 45°</p> | <p>CF</p> <p>Dd-2</p>  <p>Female Metric 24° Light Series with O-Ring Swivel – 90° Elbow ISO 12151-2-SWE-L – DKOL 90°</p> | <p>D0</p> <p>Dd-2</p>  <p>Male Metric 24° Light Series – Rigid Straight ISO 12151-2-S-L – CEL</p> |
| <p>C9</p> <p>Dd-3</p>  <p>Female Metric 24° – Swivel Heavy Series with O-Ring Straight ISO 12151-2-SWS-S – DKOS</p> | <p>OC</p> <p>Dd-3</p>  <p>Female Metric 24° – Swivel Heavy Series with O-Ring 45° Elbow ISO 12151-2 – SWE-S – DKOS 45°</p> | <p>1C</p> <p>Dd-4</p>  <p>Female Metric 24° – Swivel Heavy Series with O-Ring 90° Elbow ISO 12151-2-SWE-S – DKOS 90°</p> | <p>D2</p> <p>Dd-4</p>  <p>Male Metric 24° – Rigid Heavy Series – Straight ISO 12151-2-S-S – CES</p> |



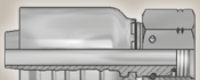
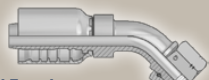
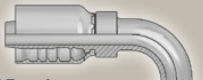

BSP

Page Dd-5 – Dd-6

| | | | |
|--------------------------------------------------------------------------------------------------------------------------------------------------------------------------------------------------------|----------------------------------------------------------------------------------------------------------------------------------------------------------------------------------------------------------------------|-----------------------------------------------------------------------------------------------------------------------------------------------------------------------------------------------------------------------|----------------------------------------------------------------------------------------------------------------------------------------------------------------------------------------------------|
| <p>EA</p> <p>Dd-5</p>  <p>BSP Swivel Female with O-Ring (60° Cone) BS 5200 – ISO 12151-6 – DKOR</p> | <p>EB</p> <p>Dd-5</p>  <p>BSP Swivel Female with O-Ring 45° Elbow (60° Cone) BS 5200 – ISO 12151-6 – DKOR 45°</p> | <p>EC</p> <p>Dd-6</p>  <p>BSP Swivel Female with O-Ring 90° Elbow (60° Cone) BS 5200 – ISO 12151-6 – DKOR 90°</p> | <p>D9</p> <p>Dd-6</p>  <p>Male BSP Parallel Pipe Rigid – Straight (60° Cone) BS5200 – AGR</p> |
|--------------------------------------------------------------------------------------------------------------------------------------------------------------------------------------------------------|----------------------------------------------------------------------------------------------------------------------------------------------------------------------------------------------------------------------|-----------------------------------------------------------------------------------------------------------------------------------------------------------------------------------------------------------------------|----------------------------------------------------------------------------------------------------------------------------------------------------------------------------------------------------|





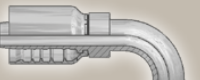







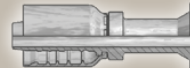
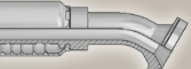

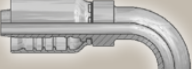
SAE

Page Dd-7 – Dd-9

| | | | |
|-------------------------------------------------------------------------------------------------------------------------------------------------------------------------------------------------|-------------------------------------------------------------------------------------------------------------------------------------------------------------------------------------|-------------------------------------------------------------------------------------------------------------------------------------------------------------------------------------------|------------------------------------------------------------------------------------------------------------------------------------------------------------------------------------------------------|
| <p>01</p> <p>Dd-7</p>  <p>Male NPTF Pipe Rigid – Straight SAE J476A / J516 – AGN</p> | <p>03</p> <p>Dd-7</p>  <p>Male JIC 37° – Rigid Straight ISO12151-5-S – AGJ</p> | <p>06</p> <p>Dd-8</p>  <p>Female JIC 37° – Swivel Straight ISO12151-5-SWS – DKJ</p> | <p>37</p> <p>Dd-9</p>  <p>Female JIC 37° – Swivel 45° Elbow ISO 12151-5-SWE 45° – DKJ 45°</p> |
| <p>39</p> <p>Dd-9</p>  <p>Female JIC 37° – Swivel 90° Elbow ISO 12151-5-SWES – DKJ 90°</p> | | | |

Flange

Page Dd-10 – Dd-20

| | | | |
|-------------------------------------------------------------------------------------------------------------------------------------------------------------------------------------------------------|----------------------------------------------------------------------------------------------------------------------------------------------------------------------------------------------------------------------------|-------------------------------------------------------------------------------------------------------------------------------------------------------------------------------------------------------------|------------------------------------------------------------------------------------------------------------------------------------------------------------------------------------------------------|
| <p>15/4A Dd-10 ISO 6162-1-Flange Straight ISO 12151-3-S-L – SFL (35.0 MPa/ 5000 psi)</p>  | <p>17/4F Dd-11 ISO 6162-1-Flange 45° Elbow ISO 12151-3 – E45S – L – SFL 45° (35.0 MPa/ 5000 psi)</p>  | <p>19/4N Dd-12 ISO 6162-1-Flange 90° Elbow ISO 12151-3-E-L – SFL 90° (35.0 MPa/ 5000 psi)</p>  | <p>6A Dd-13 ISO 6162-2-Flange Straight ISO 12151-3-S-S – SFS (42.0 MPa/ 6000 psi)</p>  |
| <p>6E Dd-14 ISO 6162-2-Flange 30° Elbow SFS 30° (42.0 MPa/ 6000 psi)</p>  | <p>6F Dd-16 ISO 6162-2-Flange 45° Elbow – Heavy Series ISO 12151-3 – E45-S – SFS 45° (42.0 MPa/ 6000 psi)</p>  | <p>6N Dd-15 ISO 6162-2-Flange 90° Elbow ISO 12151-3 – E-S – SFS 90° (42.0 MPa/ 6000 psi)</p>  | <p>X5 Dd-16 Flange – Straight Full flange system for ISO 6162-1 or ISO 6162-2</p>  |
| <p>X7 Dd-16 Flange – 45° Elbow Full flange system for ISO 6162-1 or ISO 6162-2</p>  | <p>X9 Dd-17 Flange – 90° Elbow Full flange system for ISO 6162-1 or ISO 6162-2</p>  | <p>XA Dd-17 Caterpillar® Flange Straight</p>  | <p>XF Dd-18 Caterpillar® Flange 45° Elbow</p>  |
| <p>XG Dd-18 Caterpillar® Flange 60° Elbow</p>  | <p>XN Dd-19 Caterpillar® Flange 90° Elbow</p>  | <p>K5 Dd-19 Komatsu® Flange Straight</p>  | <p>K7 Dd-20 Komatsu® Flange 45° Elbow</p>  |
| <p>K9 Dd-20 Komatsu® Flange 90° Elbow</p>  | | | |

ORFS

Page Dd-21 – Dd-23

| | | | |
|-------------------------------------------------------------------------------------------------------------------------------------------------------------------------------------------------------|---------------------------------------------------------------------------------------------------------------------------------------------------------------------------------------------------------|--------------------------------------------------------------------------------------------------------------------------------------------------------------------------------------------------------------------|----------------------------------------------------------------------------------------------------------------------------------------------------------------------------------------------------------------------|
| <p>JC Dd-21 Female ORFS Swivel – Straight Short ISO 12151-1 – SWSA SAE J516 – ORFS</p>  | <p>J7 Dd-21 Female ORFS – Swivel 45° Elbow ISO 12151-1 – SWE 45° SAE J516 – ORFS 45°</p>  | <p>J9 Dd-22 Female ORFS – Swivel 90° Elbow – Short Drop ISO 12151-1 – SWES SAE J516 – ORFS 90°</p>  | <p>J1 Dd-22 Female ORFS – Swivel 90° Elbow – Long Drop ISO 12151-1 – SWEL SAE J516 – ORFS 90° L</p>  |
| <p>JM Dd-23 ORFS Male ISO 12151-1-S – SAE J516</p>  | | | |

French Standard

Page Dd-24

FG
Dd-24
Male French Gas Series
Rigid – Straight (24° Cone)



A large range of special hose fittings
for the MRO market can be found
on page Dd-25

CA Female Metric 24° Light Series with O-Ring Swivel – Straight

ISO 12151-2-SWS-L – DKOL

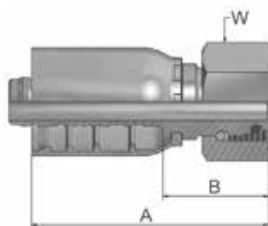

| Part Number | Hose I.D. | | | | Thread metric | Tube O.D. mm | A mm | B mm | W mm |
|-------------|-----------|-------|------|------|------------------|--------------------|---------|---------|---------|
| | DN | Inch | Size | mm | | | | | |
| 1CA77-15-8 | 12 | 1/2 | -8 | 12,7 | M22x1,5 | 15 | 63 | 28 | 27 |
| 1CA77-18-10 | 16 | 5/8 | -10 | 15,9 | M26x1,5 | 18 | 66 | 27 | 32 |
| 1CA77-18-12 | 19 | 3/4 | -12 | 19,1 | M26x1,5 | 18 | 74 | 28 | 32 |
| 1CA77-22-12 | 19 | 3/4 | -12 | 19,1 | M30x2 | 22 | 73 | 27 | 36 |
| 1CA77-22-16 | 25 | 1 | -16 | 25,4 | M30x2 | 22 | 88 | 33 | 36 |
| 1CA77-28-16 | 25 | 1 | -16 | 25,4 | M36x2 | 28 | 89 | 35 | 41 |
| 1CA77-35-20 | 31 | 1 1/4 | -20 | 31,8 | M45x2 | 35 | 100 | 37 | 50 |
| 1CA77-42-24 | 38 | 1 1/2 | -24 | 38,1 | M52x2 | 42 | 106 | 39 | 60 |

Fittings with standard O-ring seals can be used for temperatures from -40 °C up to +105 °C.
O-rings see section Eb. Special O-rings are available on request.

CE Female Metric 24° Light Series with O-Ring Swivel – 45° Elbow

ISO 12151-2-SWE -L – DKOL 45°

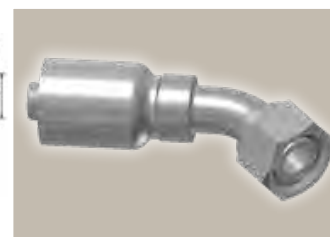
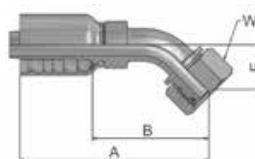

| Part Number | Hose I.D. | | | | Thread metric | Tube O.D. mm | A mm | B mm | E mm | W mm |
|-------------|-----------|-------|------|------|------------------|--------------------|---------|---------|---------|---------|
| | DN | Inch | Size | mm | | | | | | |
| 1CE77-15-8 | 12 | 1/2 | -8 | 12,7 | M22x1,5 | 15 | 84 | 49 | 24 | 27 |
| 1CE77-22-12 | 19 | 3/4 | -12 | 19,1 | M30x2 | 22 | 120 | 74 | 29 | 36 |
| 1CE77-28-16 | 25 | 1 | -16 | 25,4 | M36x2 | 28 | 142 | 88 | 33 | 41 |
| 1CE77-35-20 | 31 | 1 1/4 | -20 | 31,8 | M45x2 | 35 | 162 | 98 | 37 | 50 |
| 1CE77-42-24 | 38 | 1 1/2 | -24 | 38,1 | M52x2 | 42 | 201 | 134 | 49 | 60 |

Fittings with standard O-ring seals can be used for temperatures from -40 °C up to +105 °C.
O-rings see section Eb. Special O-rings are available on request.

77 Series

Approved **fitting series** for hose types, depending on size:

| | | | | | | | | | | | | | | | |
|-----------|--------|--------|-------|-----|-------|-------|-----|-------|-------|-----|-------|-------|-------|------|-----|
| 77 | 387 | 387ST | 387TC | 487 | 487ST | 487TC | 787 | 787TC | 787ST | 797 | 797TC | 797ST | 797RH | SX42 | ... |
| | SX42LT | SX42TC | | | | | | | | | | | | | |

High Pressure
DIN – Metric

Parkrimp No-Skive Fittings
77 Series

CF Female Metric 24° Light Series with O-Ring Swivel – 90° Elbow

ISO 12151-2-SWE-L – DKOL 90°

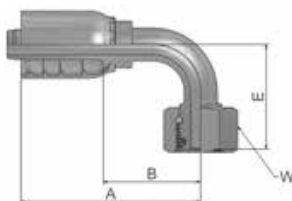

| Part Number | Hose I.D. | | | | Thread metric | Tube O.D. mm | A mm | B mm | E mm | W mm |
|-------------|-----------|-------|------|------|------------------|--------------------|---------|---------|---------|---------|
| | DN | Inch | Size | mm | | | | | | |
| 1CF77-15-8 | 12 | 1/2 | -8 | 12,7 | M22x1,5 | 15 | 76 | 41 | 45 | 27 |
| 1CF77-18-10 | 16 | 5/8 | -10 | 15,9 | M26x1,5 | 18 | 92 | 53 | 49 | 32 |
| 1CF77-18-12 | 19 | 3/4 | -12 | 19,1 | M26x1,5 | 18 | 108 | 62 | 56 | 32 |
| 1CF77-22-12 | 19 | 3/4 | -12 | 19,1 | M30x2 | 22 | 108 | 62 | 59 | 36 |
| 1CF77-28-16 | 25 | 1 | -16 | 25,4 | M36x2 | 28 | 131 | 77 | 69 | 41 |
| 1CF77-35-20 | 31 | 1 1/4 | -20 | 31,8 | M45x2 | 35 | 151 | 87 | 79 | 50 |
| 1CF77-42-24 | 38 | 1 1/2 | -24 | 38,1 | M52x2 | 42 | 179 | 112 | 101 | 60 |

Fittings with standard O-ring seals can be used for temperatures from -40 °C up to +105 °C.
O-rings see section Eb. Special O-rings are available on request.

D0 Male Metric 24° Light Series – Rigid Straight

ISO 12151-2-S-L – CEL

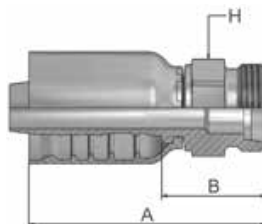

| Part Number | Hose I.D. | | | | Thread metric | A mm | B mm | H mm |
|-------------|-----------|------|------|------|------------------|---------|---------|---------|
| | DN | Inch | Size | mm | | | | |
| 1D077-15-8 | 12 | 1/2 | -8 | 12,7 | M22x1,5 | 61 | 27 | 22 |
| 1D077-18-10 | 16 | 5/8 | -10 | 15,9 | M26x1,5 | 68 | 30 | 27 |
| 1D077-22-12 | 19 | 3/4 | -12 | 19,1 | M30x2 | 82 | 36 | 30 |
| 1D077-28-16 | 25 | 1 | -16 | 25,4 | M36x2 | 92 | 38 | 36 |

Approved **fitting series** for hose types, depending on size:

| | | | | | | | | | | | | | | | |
|-----------|--------|-------|--------|-----|-------|-------|-----|-------|-------|-----|-------|-------|-------|------|-----|
| 77 | 387 | 387ST | 387TC | 487 | 487ST | 487TC | 787 | 787TC | 787ST | 797 | 797TC | 797ST | 797RH | SX42 | ... |
| | SX42LT | | SX42TC | | | | | | | | | | | | |



Dd-2

Catalogue 4400/UK

C9 Female Metric 24° – Swivel Heavy Series with O-Ring Straight

ISO 12151-2-SWS-S – DKOS

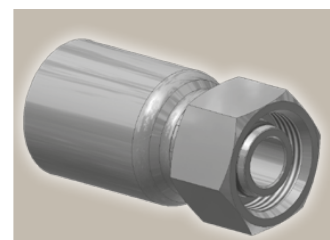
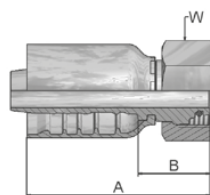

| Part Number | Hose I.D. | | | | Thread metric | A mm | B mm | W mm |
|------------------|-----------|-------|------|------|------------------|---------|---------|---------|
| | DN | Inch | Size | mm | | | | |
| 1C977-12-8 | 12 | 1/2 | -8 | 12,7 | M20x1,5 | 61 | 26 | 24 |
| 1C977-16-8 | 12 | 1/2 | -8 | 12,7 | M24x1,5 | 60 | 25 | 30 |
| 1C977-16-10 | 16 | 5/8 | -10 | 15,9 | M24x1,5 | 67 | 28 | 30 |
| 1C977-20-10 | 16 | 5/8 | -10 | 15,9 | M30x2 | 68 | 28 | 36 |
| 1C977-20-12 | 19 | 3/4 | -12 | 19,1 | M30x2 | 76 | 30 | 36 |
| 1C977-25-12 | 19 | 3/4 | -12 | 19,1 | M36x2 | 76,6 | 30,6 | 46 |
| 1C977-25-12-SW41 | 19 | 3/4 | -12 | 19,1 | M36x2 | 77 | 31 | 41 |
| 1C977-30-12 | 19 | 3/4 | -12 | 19,1 | M42x2 | 83 | 37 | 50 |
| 1C977-25-16 | 25 | 1 | -16 | 25,4 | M36x2 | 86 | 35 | 46 |
| 1C977-30-16 | 25 | 1 | -16 | 25,4 | M42x2 | 89 | 35 | 50 |
| 1C977-30-20 | 31 | 1 1/4 | -20 | 31,8 | M42x2 | 102 | 39 | 50 |
| 1C977-38-20 | 31 | 1 1/4 | -20 | 31,8 | M52x2 | 100 | 36 | 60 |
| 1C977-38-24 | 38 | 1 1/2 | -24 | 38,1 | M52x2 | 106 | 39 | 60 |

Fittings with standard O-ring seals can be used for temperatures from -40 °C up to +105 °C.
O-rings see section Eb. Special O-rings are available on request.

OC Female Metric 24° – Swivel Heavy Series with O-Ring 45° Elbow

ISO 12151-2 – SWE -S – DKOS 45°

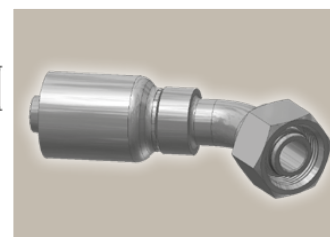
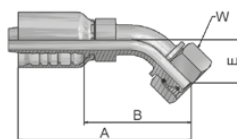

| Part Number | Hose I.D. | | | | Thread metric | A mm | B mm | E mm | W mm |
|------------------|-----------|-------|------|------|------------------|---------|---------|---------|---------|
| | DN | Inch | Size | mm | | | | | |
| 10C77-16-8 | 12 | 1/2 | -8 | 12,7 | M24x1,5 | 83 | 49 | 24 | 30 |
| 10C77-12-10 | 16 | 5/8 | -10 | 15,9 | M20x1,5 | 105 | 66 | 26 | 24 |
| 10C77-16-10 | 16 | 5/8 | -10 | 15,9 | M24x1,5 | 111 | 64 | 24 | 30 |
| 10C77-20-10 | 16 | 5/8 | -10 | 15,9 | M30x2 | 107 | 68 | 28 | 36 |
| 10C77-20-12 | 19 | 3/4 | -12 | 19,1 | M30x2 | 120 | 74 | 30 | 36 |
| 10C77-25-12 | 19 | 3/4 | -12 | 19,1 | M36x2 | 119 | 73 | 29 | 46 |
| 10C77-25-12-SW41 | 19 | 3/4 | -12 | 19,1 | M36x2 | 119 | 73 | 29 | 41 |
| 10C77-30-12 | 19 | 3/4 | -12 | 19,1 | M42x2 | 121 | 75 | 30 | 50 |
| 10C77-25-16 | 25 | 1 | -16 | 25,4 | M36x2 | 142 | 88 | 33 | 46 |
| 10C77-30-16 | 25 | 1 | -16 | 25,4 | M42x2 | 142 | 88 | 33 | 50 |
| 10C77-30-20 | 31 | 1 1/4 | -20 | 31,8 | M42x2 | 155 | 91 | 34 | 50 |
| 10C77-38-20 | 31 | 1 1/4 | -20 | 31,8 | M52x2 | 161 | 97 | 37 | 60 |
| 10C77-38-24 | 38 | 1 1/2 | -24 | 38,1 | M52x2 | 195 | 128 | 49 | 60 |

Fittings with standard O-ring seals can be used for temperatures from -40 °C up to +105 °C.
O-rings see section Eb. Special O-rings are available on request.

Approved **fitting series** for hose types, depending on size:

| | | | | | | | | | | | | | | | |
|-----------|--------|-------|--------|-----|-------|-------|-----|-------|-------|-----|-------|-------|-------|------|-----|
| 77 | 387 | 387ST | 387TC | 487 | 487ST | 487TC | 787 | 787TC | 787ST | 797 | 797TC | 797ST | 797RH | SX42 | ... |
| | SX42LT | | SX42TC | | | | | | | | | | | | |

1C Female Metric 24° – Swivel Heavy Series with O-Ring 90° Elbow

ISO 12151-2-SWE-S – DKOS 90°

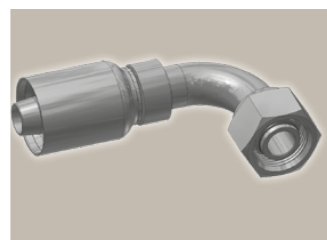
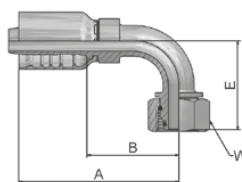

| Part Number | Hose I.D. | | | | Thread metric | A mm | B mm | E mm | W mm |
|------------------|-----------|-------|------|------|------------------|---------|---------|---------|---------|
| | DN | Inch | Size | mm | | | | | |
| 11C77-16-8 | 12 | 1/2 | -8 | 12,7 | M24x1,5 | 77 | 42 | 45 | 30 |
| 11C77-16-10 | 16 | 5/8 | -10 | 15,9 | M24x1,5 | 92 | 53 | 45 | 30 |
| 11C77-20-10 | 16 | 5/8 | -10 | 15,9 | M30x2 | 92 | 53 | 53 | 36 |
| 11C77-20-12 | 19 | 3/4 | -12 | 19,1 | M30x2 | 108 | 62 | 60 | 36 |
| 11C77-25-12 | 19 | 3/4 | -12 | 19,1 | M36x2 | 108 | 62 | 58,5 | 46 |
| 11C77-25-12-SW41 | 19 | 3/4 | -12 | 19,1 | M36x2 | 108 | 62 | 59 | 41 |
| 11C77-30-12 | 19 | 3/4 | -12 | 19,1 | M42x2 | 108 | 62 | 61 | 50 |
| 11C77-25-16 | 25 | 1 | -16 | 25,4 | M36x2 | 131 | 77 | 69 | 46 |
| 11C77-30-16 | 25 | 1 | -16 | 25,4 | M42x2 | 131 | 77 | 69 | 50 |
| 11C77-30-20 | 31 | 1 1/4 | -20 | 31,8 | M42x2 | 145 | 82 | 73 | 50 |
| 11C77-38-20 | 31 | 1 1/4 | -20 | 31,8 | M52x2 | 151 | 87 | 78 | 60 |
| 11C77-38-24 | 38 | 1 1/2 | -24 | 38,1 | M52x2 | 179 | 112 | 101 | 60 |

Fittings with standard O-ring seals can be used for temperatures from -40 °C up to +105 °C.
O-rings see section Eb. Special O-rings are available on request.

D2 Male Metric 24° – Rigid Heavy Series – Straight

ISO 12151-2-S-S – CES

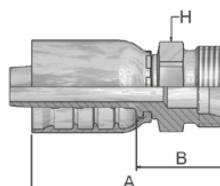

| Part Number | Hose I.D. | | | | Thread metric | A mm | B mm | H mm |
|-------------|-----------|-------|------|------|------------------|---------|---------|---------|
| | DN | Inch | Size | mm | | | | |
| 1D277-16-8 | 12 | 1/2 | -8 | 12,7 | M24x1,5 | 64 | 30 | 24 |
| 1D277-16-10 | 16 | 5/8 | -10 | 15,9 | M24x1,5 | 69 | 30 | 24 |
| 1D277-20-10 | 16 | 5/8 | -10 | 15,9 | M30x2 | 72 | 34 | 30 |
| 1D277-20-12 | 19 | 3/4 | -12 | 19,1 | M30x2 | 84 | 38 | 30 |
| 1D277-25-12 | 19 | 3/4 | -12 | 19,1 | M36x2 | 86 | 40 | 36 |
| 1D277-25-16 | 25 | 1 | -16 | 25,4 | M36x2 | 96 | 42 | 36 |
| 1D277-30-16 | 25 | 1 | -16 | 25,4 | M42x2 | 99 | 45 | 46 |
| 1D277-30-20 | 31 | 1 1/4 | -20 | 31,8 | M42x2 | 110 | 47 | 46 |
| 1D277-38-20 | 31 | 1 1/4 | -20 | 31,8 | M52x2 | 114 | 51 | 55 |
| 1D277-38-24 | 38 | 1 1/2 | -24 | 38,1 | M52x2 | 120 | 53 | 55 |

Approved **fitting series** for hose types, depending on size:

| | | | | | | | | | | | | | | | |
|----|--------|-------|--------|-----|-------|-------|-----|-------|-------|-----|-------|-------|-------|------|-----|
| 77 | 387 | 387ST | 387TC | 487 | 487ST | 487TC | 787 | 787TC | 787ST | 797 | 797TC | 797ST | 797RH | SX42 | ... |
| | SX42LT | | SX42TC | | | | | | | | | | | | |



EA **BSP Swivel Female
with O-Ring (60° Cone)**
BS 5200 – ISO 12151-6 – DKOR

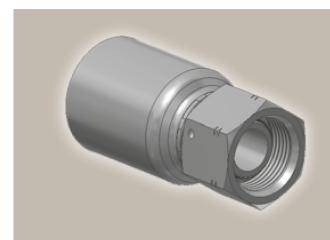
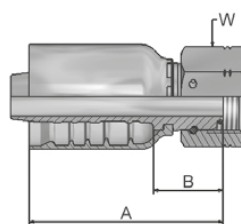

| Part Number | Hose I.D. | | | | Thread BSP | A mm | B mm | W mm |
|-------------|-----------|-------|------|------|---------------|---------|---------|---------|
| | DN | Inch | Size | mm | | | | |
| 1EA77-8-8 | 12 | 1/2 | -8 | 12,7 | 1/2x14 | 58 | 23 | 27 |
| 1EA77-10-10 | 16 | 5/8 | -10 | 15,9 | 5/8x14 | 62 | 23 | 30 |
| 1EA77-12-10 | 16 | 5/8 | -10 | 15,9 | 3/4x14 | 63 | 24 | 32 |
| 1EA77-12-12 | 19 | 3/4 | -12 | 19,1 | 3/4x14 | 72 | 26 | 32 |
| 1EA77-16-12 | 19 | 3/4 | -12 | 19,1 | 1x11 | 82 | 36 | 41 |
| 1EA77-12-16 | 25 | 1 | -16 | 25,4 | 3/4x14 | 83 | 29 | 32 |
| 1EA77-16-16 | 25 | 1 | -16 | 25,4 | 1x11 | 90 | 36 | 41 |
| 1EA77-20-20 | 31 | 1 1/4 | -20 | 31,8 | 1 1/4x11 | 96 | 33 | 50 |
| 1EA77-24-24 | 38 | 1 1/2 | -24 | 38,1 | 1 1/2 | 103 | 36 | 55 |
| 1EA77-32-32 | 51 | 2 | -32 | 50,8 | 2 | 118 | 40 | 70 |

Fittings with standard O-ring seals can be used for temperatures from -40 °C up to +105 °C.
O-rings see section Eb. Special O-rings are available on request.

EB **BSP Swivel Female
with O-Ring
45° Elbow (60° Cone)**
BS 5200 – ISO 12151-6 – DKOR 45°

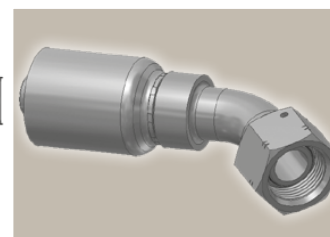
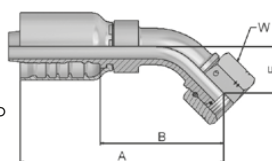

| Part Number | Hose I.D. | | | | Thread BSP | A mm | B mm | E mm | W mm |
|-------------|-----------|-------|------|------|---------------|---------|---------|---------|---------|
| | DN | Inch | Size | mm | | | | | |
| 1EB77-8-8 | 12 | 1/2 | -8 | 12,7 | 1/2x14 | 80 | 45 | 20 | 27 |
| 1EB77-10-10 | 16 | 5/8 | -10 | 15,9 | 5/8x14 | 101 | 62 | 22 | 30 |
| 1EB77-12-10 | 16 | 5/8 | -10 | 15,9 | 3/4x14 | 103 | 64 | 24 | 32 |
| 1EB77-12-12 | 19 | 3/4 | -12 | 19,1 | 3/4x14 | 117 | 71 | 27 | 32 |
| 1EB77-16-12 | 19 | 3/4 | -12 | 19,1 | 1x11 | 120 | 74 | 29 | 41 |
| 1EB77-16-16 | 25 | 1 | -16 | 25,4 | 1x11 | 133 | 79 | 35 | 41 |
| 1EB77-20-20 | 31 | 1 1/4 | -20 | 31,8 | 1 1/4x11 | 164 | 100 | 35 | 50 |
| 1EB77-24-24 | 38 | 1 1/2 | -24 | 38,1 | 1 1/2 | 197 | 130 | 50 | 55 |
| 1EB77-32-32 | 51 | 2 | -32 | 50,8 | 2 | 255 | 178 | 86 | 70 |

Fittings with standard O-ring seals can be used for temperatures from -40 °C up to +105 °C.
O-rings see section Eb. Special O-rings are available on request.

Approved **fitting series** for hose types, depending on size:

| | | | | | | | | | | | | | | | |
|-----------|--------|-------|--------|-----|-------|-------|-----|-------|-------|-----|-------|-------|-------|------|-----|
| 77 | 387 | 387ST | 387TC | 487 | 487ST | 487TC | 787 | 787TC | 787ST | 797 | 797TC | 797ST | 797RH | SX42 | ... |
| | SX42LT | | SX42TC | | | | | | | | | | | | |



EC BSP Swivel Female with O-Ring 90° Elbow (60° Cone)

BS 5200 – ISO 12151-6 – DKOR 90°

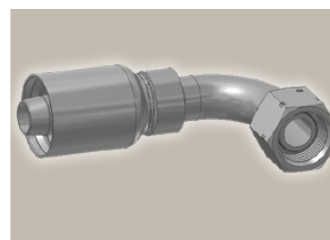
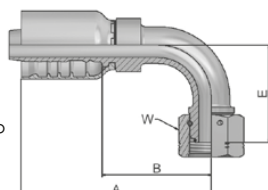

| Part Number | Hose I.D. | | | | Thread BSP | A mm | B mm | E mm | W mm |
|-------------|-----------|-------|------|------|---------------|---------|---------|---------|---------|
| | DN | Inch | Size | mm | | | | | |
| 1EC77-8-8 | 12 | 1/2 | -8 | 12,7 | 1/2x14 | 76 | 41 | 40 | 27 |
| 1EC77-10-10 | 16 | 5/8 | -10 | 15,9 | 5/8x14 | 92 | 53 | 44 | 30 |
| 1EC77-12-10 | 16 | 5/8 | -10 | 15,9 | 3/4x14 | 92 | 53 | 47 | 32 |
| 1EC77-12-12 | 19 | 3/4 | -12 | 19,1 | 3/4x14 | 108 | 62 | 55 | 32 |
| 1EC77-16-12 | 19 | 3/4 | -12 | 19,1 | 1x11 | 108 | 62 | 59 | 41 |
| 1EC77-16-16 | 25 | 1 | -16 | 25,4 | 1x11 | 131 | 77 | 72 | 41 |
| 1EC77-20-20 | 31 | 1 1/4 | -20 | 31,8 | 1 1/4x11 | 151 | 87 | 75 | 50 |
| 1EC77-24-24 | 38 | 1 1/2 | -24 | 38,1 | 1 1/2 | 179 | 112 | 103 | 55 |
| 1EC77-32-32 | 51 | 2 | -32 | 50,8 | 2 | 236 | 159 | 150 | 70 |

Fittings with standard O-ring seals can be used for temperatures from -40 °C up to +105 °C.
O-rings see section Eb. Special O-rings are available on request.

D9 Male BSP Parallel Pipe Rigid – Straight (60° Cone)

BS5200 – AGR

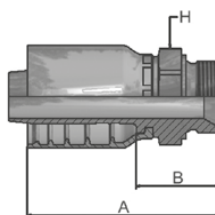

| Part Number | Hose I.D. | | | | Thread BSP | A mm | B mm | H mm |
|-------------|-----------|-------|------|------|---------------|---------|---------|---------|
| | DN | Inch | Size | mm | | | | |
| 1D977-8-8 | 12 | 1/2 | -8 | 12,7 | 1/2x14 | 68 | 33 | 27 |
| 1D977-10-10 | 16 | 5/8 | -10 | 15,9 | 5/8x14 | 74 | 36 | 30 |
| 1D977-12-12 | 19 | 3/4 | -12 | 19,1 | 3/4x14 | 87 | 41 | 32 |
| 1D977-16-12 | 19 | 3/4 | -12 | 19,1 | 1x11 | 91 | 45 | 41 |
| 1D977-16-16 | 25 | 1 | -16 | 25,4 | 1x11 | 91 | 45 | 41 |
| 1D977-20-16 | 25 | 1 | -16 | 25,4 | 1 1/4x11 | 103 | 49 | 50 |
| 1D977-20-20 | 31 | 1 1/4 | -20 | 31,8 | 1 1/4x11 | 113 | 50 | 50 |
| 1D977-24-24 | 38 | 1 1/2 | -24 | 38,1 | 1 1/2x11 | 124 | 57 | 55 |

Approved **fitting series** for hose types, depending on size:

| | | | | | | | | | | | | | | | |
|-----------|--------|--------|-------|-----|-------|-------|-----|-------|-------|-----|-------|-------|-------|------|-----|
| 77 | 387 | 387ST | 387TC | 487 | 487ST | 487TC | 787 | 787TC | 787ST | 797 | 797TC | 797ST | 797RH | SX42 | ... |
| | SX42LT | SX42TC | | | | | | | | | | | | | |



01 Male NPTF Pipe Rigid – Straight

SAE J476A / J516 – AGN

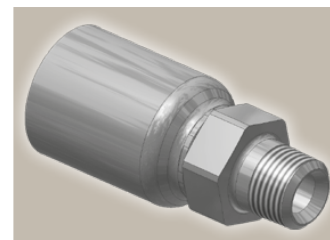
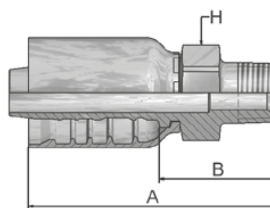

| Part Number | Hose I.D. | | | | Thread NPTF | A mm | B mm | H mm |
|-------------|-----------|-------|------|------|----------------|---------|---------|---------|
| | DN | Inch | Size | mm | | | | |
| 10177-8-8 | 12 | 1/2 | -8 | 12,7 | 1/2-14 | 69 | 35 | 22 |
| 10177-8-12 | 19 | 3/4 | -12 | 19,1 | 1/2-14 | 87 | 41 | 30 |
| 10177-12-12 | 19 | 3/4 | -12 | 19,1 | 3/4-14 | 87 | 41 | 30 |
| 10177-16-16 | 25 | 1 | -16 | 25,4 | 1-11 1/2 | 103 | 49 | 36 |
| 10177-20-20 | 31 | 1 1/4 | -20 | 31,8 | 1 1/4-11 1/2 | 116 | 53 | 46 |
| 10177-24-24 | 38 | 1 1/2 | -24 | 38,1 | 1 1/2-11 1/2 | 124 | 57 | 50 |
| 10177-32-32 | 51 | 2 | -32 | 50,8 | 2-11 1/2 | 143 | 66 | 65 |

All sizes of 10177 fittings are rated at 35,0 MPa working pressure.

03 Male JIC 37° – Rigid Straight

ISO12151-5-S – AGJ

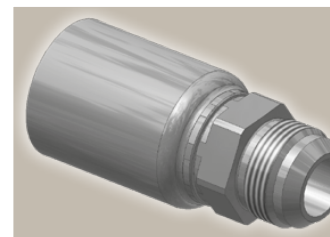
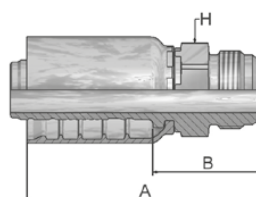

| Part Number | Hose I.D. | | | | Thread UNF | A mm | B mm | H mm |
|-------------|-----------|-------|------|------|---------------|---------|---------|---------|
| | DN | Inch | Size | mm | | | | |
| 10377-8-8 | 12 | 1/2 | -8 | 12,7 | 3/4x16 | 66,45 | 32 | 22 |
| 10377-10-8 | 12 | 1/2 | -8 | 12,7 | 7/8x14 | 69 | 34 | 24 |
| 10377-12-8 | 12 | 1/2 | -8 | 12,7 | 1 1/16x12 | 77 | 42 | 27 |
| 10377-10-10 | 16 | 5/8 | -10 | 15,9 | 7/8x14 | 76 | 38 | 24 |
| 10377-12-10 | 16 | 5/8 | -10 | 15,9 | 1 1/16x12 | 82 | 43 | 30 |
| 10377-10-12 | 19 | 3/4 | -12 | 19,1 | 7/8x14 | 87 | 41 | 30 |
| 10377-12-12 | 19 | 3/4 | -12 | 19,1 | 1 1/16x12 | 89 | 43 | 30 |
| 10377-16-12 | 19 | 3/4 | -12 | 19,1 | 1 5/16x12 | 92 | 46 | 36 |
| 10377-16-16 | 25 | 1 | -16 | 25,4 | 1 5/16x12 | 101,4 | 47 | 36 |
| 10377-20-16 | 25 | 1 | -16 | 25,4 | 1 5/8x12 | 110 | 56 | 50 |
| 10377-20-20 | 31 | 1 1/4 | -20 | 31,8 | 1 5/8x12 | 118 | 55 | 50 |
| 10377-32-32 | 51 | 2 | -32 | 50,8 | 2 1/2x12 | 148 | 71 | 65 |

All sizes of 10377 fittings are rated at 35,0 MPa working pressure.

Approved **fitting series** for hose types, depending on size:

| | | | | | | | | | | | | | | | |
|-----------|--------|-------|--------|-----|-------|-------|-----|-------|-------|-----|-------|-------|-------|------|-----|
| 77 | 387 | 387ST | 387TC | 487 | 487ST | 487TC | 787 | 787TC | 787ST | 797 | 797TC | 797ST | 797RH | SX42 | ... |
| | SX42LT | | SX42TC | | | | | | | | | | | | |



06 Female JIC 37° – Swivel Straight

ISO12151-5-SWS – DKJ

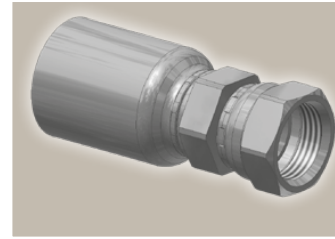
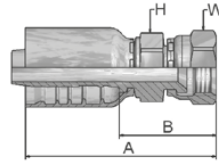

| Part Number | Hose I.D. | | | | Thread UNF | A mm | B mm | H mm | W mm |
|-------------|---------------|-------|------|------|-------------------|---------|---------|-------------|-------------|
| | DN | Inch | Size | mm | | | | | |
| 10677-8-8 | 12 | 1/2 | -8 | 12,7 | 3/4x16 | 71 | 37 | 22 | 22 |
| 10677-10-8 | 12 | 1/2 | -8 | 12,7 | 7/8x14 | 74 | 39 | 22 | 27 |
| 10677-12-8 | 12 | 1/2 | -8 | 12,7 | 1 1/16x12 | 80 | 46 | 30 | 32 |
| 10677-10-10 | 16 | 5/8 | -10 | 15,9 | 7/8x14 | 81 | 42 | 24 | 27 |
| 10677-12-10 | 16 | 5/8 | -10 | 15,9 | 1 1/16x12 | 84 | 45 | 30 | 32 |
| 10677-10-12 | 19 | 3/4 | -12 | 19,1 | 7/8x14 | 92 | 46 | 30 | 27 |
| 10677-12-12 | 19 | 3/4 | -12 | 19,1 | 1 1/16x12 | 94 | 48 | 30 | 32 |
| 10677-14-12 | 19 | 3/4 | -12 | 19,1 | 1 3/16x12 | 99 | 53 | 36 | 36 |
| 10677-16-12 | 19 | 3/4 | -12 | 19,1 | 1 5/16x12 | 99 | 53 | 36 | 41 |
| 10677-12-16 | 25 | 1 | -16 | 25,4 | 1 1/16x12 | 102 | 48 | 36 | 32 |
| 10677-16-16 | 25 | 1 | -16 | 25,4 | 1 5/16x12 | 106 | 52 | 36 | 41 |
| 10677-20-16 | 25 | 1 | -16 | 25,4 | 1 5/8x12 | 109 | 55 | 41 | 50 |
| 10677-16-20 | 31 | 1 1/4 | -20 | 31,8 | 1 5/16x12 | 120 | 57 | 46 | 41 |
| 10677-20-20 | 31 | 1 1/4 | -20 | 31,8 | 1 5/8 12 | 124 | 60 | 46 | 50 |
| 10677-24-20 | 31 | 1 1/4 | -20 | 31,8 | 1 7/8x12 | 108 | 44 | 50 | 60 |
| 10677-24-24 | 38 | 1 1/2 | -24 | 38,1 | 1 7/8x12 | 136 | 69 | 50 | 60 |
| 10677-32-32 | 51 | 2 | -32 | 50,8 | 2 1/2x12 | 160 | 83 | 65 | 75 |

All sizes of 10677 fittings are rated at 35,0 MPa working pressure.

Approved **fitting series** for hose types, depending on size:

| | | | | | | | | | | | | | | | |
|-----------|--------|--------|-------|-----|-------|-------|-----|-------|-------|-----|-------|-------|-------|------|-----|
| 77 | 387 | 387ST | 387TC | 487 | 487ST | 487TC | 787 | 787TC | 787ST | 797 | 797TC | 797ST | 797RH | SX42 | ... |
| | SX42LT | SX42TC | | | | | | | | | | | | | |



37 Female JIC 37° – Swivel 45° Elbow

ISO 12151-5-SWE 45° – DKJ 45°

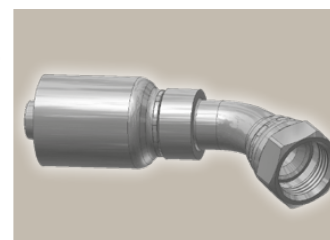
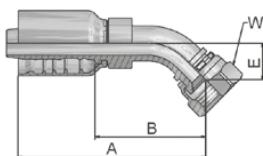

| Part Number | Hose I.D. | | | | Thread UNF | A mm | B mm | E mm | W mm |
|-------------|-----------|-------|------|------|---------------|---------|---------|---------|---------|
| | DN | Inch | Size | mm | | | | | |
| 13777-8-8 | 12 | 1/2 | -8 | 12,7 | 3/4x16 | 73 | 38 | 15 | 22 |
| 13777-10-8 | 12 | 1/2 | -8 | 12,7 | 7/8x14 | 78 | 43 | 16 | 27 |
| 13777-12-8 | 12 | 1/2 | -8 | 12,7 | 1 1/16x12 | 79 | 44 | 21 | 32 |
| 13777-10-10 | 16 | 5/8 | -10 | 15,9 | 7/8x14 | 93 | 54 | 16 | 27 |
| 13777-12-10 | 16 | 5/8 | -10 | 15,9 | 1 1/16x12 | 100 | 61 | 21 | 32 |
| 13777-10-12 | 19 | 3/4 | -12 | 19,1 | 7/8x14 | 102 | 56 | 16 | 27 |
| 13777-12-12 | 19 | 3/4 | -12 | 19,1 | 1 1/16x12 | 111 | 65 | 21 | 32 |
| 13777-16-12 | 19 | 3/4 | -12 | 19,1 | 1 5/16x12 | 114 | 68 | 24 | 41 |
| 13777-16-16 | 25 | 1 | -16 | 25,4 | 1 5/16x12 | 133 | 79 | 24 | 41 |
| 13777-20-20 | 31 | 1 1/4 | -20 | 31,8 | 1 5/8x12 | 153 | 90 | 32 | 50 |
| 13777-24-24 | 38 | 1 1/2 | -24 | 38,1 | 1 7/8x12 | 201 | 134 | 58 | 60 |
| 13777-32-32 | 51 | 2 | -32 | 50,8 | 2 1/2x12 | 258 | 181 | 72 | 75 |

All sizes of 13777 fittings are rated at 35,0 MPa working pressure.

39 Female JIC 37° – Swivel 90° Elbow

ISO 12151-5-SWES – DKJ 90°

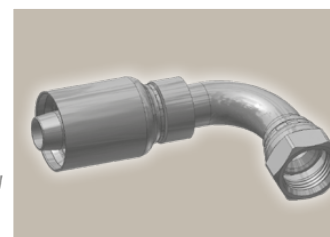
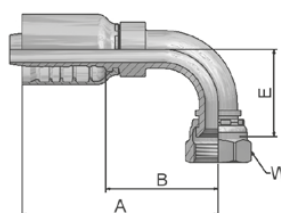

| Part Number | Hose I.D. | | | | Thread UNF | A mm | B mm | E mm | W mm |
|-------------|-----------|-------|------|------|---------------|---------|---------|---------|---------|
| | DN | Inch | Size | mm | | | | | |
| 13977-8-8 | 12 | 1/2 | -8 | 12,7 | 3/4x16 | 71 | 36 | 29 | 22 |
| 13977-10-8 | 12 | 1/2 | -8 | 12,7 | 7/8x14 | 71 | 36 | 32 | 27 |
| 13977-12-8 | 12 | 1/2 | -8 | 12,7 | 1 1/16x12 | 76 | 41 | 48 | 32 |
| 13977-10-10 | 16 | 5/8 | -10 | 15,9 | 7/8x14 | 88 | 50 | 33 | 27 |
| 13977-12-10 | 16 | 5/8 | -10 | 15,9 | 1 1/16x12 | 92 | 53 | 48 | 32 |
| 13977-10-12 | 19 | 3/4 | -12 | 19,1 | 7/8x14 | 97 | 51 | 33 | 27 |
| 13977-12-12 | 19 | 3/4 | -12 | 19,1 | 1 1/16x12 | 108 | 62 | 48 | 32 |
| 13977-16-12 | 19 | 3/4 | -12 | 19,1 | 1 5/16x12 | 108 | 62 | 56 | 41 |
| 13977-16-16 | 25 | 1 | -16 | 25,4 | 1 5/16x12 | 131 | 77 | 74 | 41 |
| 13977-20-20 | 31 | 1 1/4 | -20 | 31,8 | 1 5/8x12 | 148 | 84 | 78 | 50 |
| 13977-24-24 | 38 | 1 1/2 | -24 | 38,1 | 1 7/8x12 | 175 | 108 | 102 | 60 |
| 13977-32-32 | 51 | 2 | -32 | 50,8 | 2 1/2x12 | 236 | 159 | 152 | 75 |

All sizes of 13977 fittings are rated at 35,0 MPa working pressure.

Approved **fitting series** for hose types, depending on size:

| | | | | | | | | | | | | | | | |
|-----------|--------|-------|--------|-----|-------|-------|-----|-------|-------|-----|-------|-------|-------|------|-----|
| 77 | 387 | 387ST | 387TC | 487 | 487ST | 487TC | 787 | 787TC | 787ST | 797 | 797TC | 797ST | 797RH | SX42 | ... |
| | SX42LT | | SX42TC | | | | | | | | | | | | |



15/4A ISO 6162-1-Flange Straight

ISO 12151-3-S-L – SFL
(35.0 MPa/ 5000 psi)

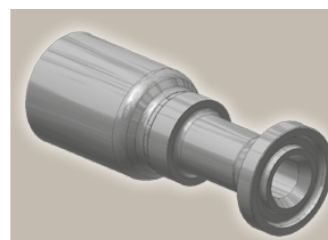
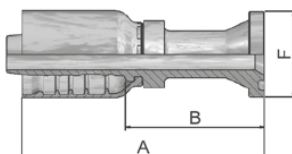

| Part Number | Hose I.D. | | | | Flange Inch | A mm | B mm | F mm |
|-------------|-----------|-------|------|------|----------------|---------|---------|---------|
| | DN | Inch | Size | mm | | | | |
| 11577-8-8 | 12 | 1/2 | -8 | 12,7 | 1/2 | 90 | 55 | 30 |
| 11577-12-8 | 12 | 1/2 | -8 | 12,7 | 3/4 | 67 | 33 | 38 |
| 11577-10-10 | 16 | 5/8 | -10 | 15,9 | 5/8 | 100 | 60 | 34 |
| 11577-12-10 | 16 | 5/8 | -10 | 15,9 | 3/4 | 75 | 36 | 38 |
| 11577-12-12 | 19 | 3/4 | -12 | 19,1 | 3/4 | 107 | 62 | 38 |
| 11577-16-12 | 19 | 3/4 | -12 | 19,1 | 1 | 88 | 42 | 45 |
| 11577-16-16 | 25 | 1 | -16 | 25,4 | 1 | 119 | 65 | 45 |
| 14A77-20-16 | 25 | 1 | -16 | 25,4 | 1 1/4 | 90 | 36 | 51 |
| 11577-16-20 | 31 | 1 1/4 | -20 | 31,8 | 1 | 130 | 66 | 45 |
| 14A77-20-20 | 31 | 1 1/4 | -20 | 31,8 | 1 1/4 | 138 | 74 | 51 |
| 14A77-24-20 | 31 | 1 1/4 | -20 | 31,8 | 1 1/2 | 100 | 37 | 60 |
| 14A77-20-24 | 38 | 1 1/2 | -24 | 38,1 | 1 1/4 | 146 | 79 | 51 |
| 14A77-24-24 | 38 | 1 1/2 | -24 | 38,1 | 1 1/2 | 140 | 73 | 60 |
| 14A77-32-24 | 38 | 1 1/2 | -24 | 38,1 | 2 | 117 | 50 | 71 |
| 14A77-32-32 | 51 | 2 | -32 | 50,8 | 2 | 163 | 86 | 71 |

SAE flange halves see in section Eb.

Fittings with standard O-ring seals can be used for temperatures from -40 °C up to +105 °C.
O-rings see section Eb. Special O-rings are available on request.

Approved **fitting series** for hose types, depending on size:

| | | | | | | | | | | | | | | | |
|-----------|--------|-------|--------|-----|-------|-------|-----|-------|-------|-----|-------|-------|-------|------|-----|
| 77 | 387 | 387ST | 387TC | 487 | 487ST | 487TC | 787 | 787TC | 787ST | 797 | 797TC | 797ST | 797RH | SX42 | ... |
| | SX42LT | | SX42TC | | | | | | | | | | | | |



17/4F ISO 6162-1-Flange 45° Elbow

ISO 12151-3 – E45S – L – SFL 45°
(35.0 MPa/ 5000 psi)

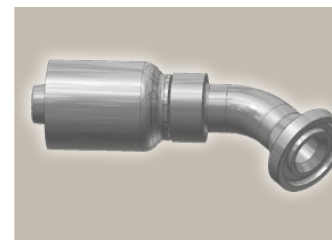
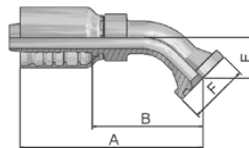

| Part Number | Hose I.D. | | | | Flange | A mm | B mm | E mm | F mm |
|-------------|---------------|-------|------|------|------------|---------|---------|---------|---------|
| | DN | Inch | Size | mm | | | | | |
| 11777-8-8 | 12 | 1/2 | -8 | 12,7 | 1/2 | 79 | 45 | 20 | 30 |
| 11777-12-8 | 12 | 1/2 | -8 | 12,7 | 3/4 | 81 | 47 | 22 | 38 |
| 11777-10-10 | 16 | 5/8 | -10 | 15,9 | 5/8 | 103 | 64 | 24 | 34 |
| 11777-12-12 | 19 | 3/4 | -12 | 19,1 | 3/4 | 116 | 70 | 26 | 38 |
| 11777-16-12 | 19 | 3/4 | -12 | 19,1 | 1 | 116 | 70 | 26 | 45 |
| 11777-16-16 | 25 | 1 | -16 | 25,4 | 1 | 130 | 76 | 32 | 45 |
| 14F77-20-16 | 25 | 1 | -16 | 25,4 | 1 1/4 | 130 | 76 | 32 | 51 |
| 14F77-20-20 | 31 | 1 1/4 | -20 | 31,8 | 1 1/4 | 167 | 104 | 38 | 51 |
| 14F77-24-20 | 31 | 1 1/4 | -20 | 31,8 | 1 1/2 | 167 | 104 | 38 | 60 |
| 14F77-24-24 | 38 | 1 1/2 | -24 | 38,1 | 1 1/2 | 192 | 125 | 44 | 60 |
| 14F77-32-24 | 38 | 1 1/2 | -24 | 38,1 | 2 | 192 | 125 | 44 | 71 |
| 14F77-32-32 | 51 | 2 | -32 | 50,8 | 2 | 211 | 134 | 56 | 71 |

SAE flange halves see in section Eb.

Fittings with standard O-ring seals can be used for temperatures from -40 °C up to +105 °C.
O-rings see section Eb. Special O-rings are available on request.

77 Series

Approved **fitting series** for hose types, depending on size:

| | | | | | | | | | | | | | | | |
|-----------|--------|-------|--------|-----|-------|-------|-----|-------|-------|-----|-------|-------|-------|------|-----|
| 77 | 387 | 387ST | 387TC | 487 | 487ST | 487TC | 787 | 787TC | 787ST | 797 | 797TC | 797ST | 797RH | SX42 | ... |
| | SX42LT | | SX42TC | | | | | | | | | | | | |

19/4N ISO 6162-1-Flange 90° Elbow

ISO 12151-3-E-L – SFL 90°
(35.0 MPa/ 5000 psi)

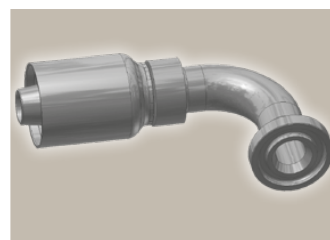
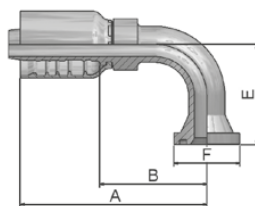

| Part Number | Hose I.D. | | | | Flange Inch | A mm | B mm | E mm | F mm |
|-------------|-----------|-------|------|------|----------------|---------|---------|---------|---------|
| | DN | Inch | Size | mm | | | | | |
| 11977-8-8 | 12 | 1/2 | -8 | 12,7 | 1/2 | 76 | 41 | 41 | 30 |
| 11977-12-8 | 12 | 1/2 | -8 | 12,7 | 3/4 | 80 | 45 | 42 | 38 |
| 11977-10-10 | 16 | 5/8 | -10 | 15,9 | 5/8 | 92 | 53 | 53 | 34 |
| 11977-12-12 | 19 | 3/4 | -12 | 19,1 | 3/4 | 108 | 62 | 58 | 38 |
| 11977-16-12 | 19 | 3/4 | -12 | 19,1 | 1 | 108 | 62 | 58 | 45 |
| 11977-16-16 | 25 | 1 | -16 | 25,4 | 1 | 120 | 66 | 70 | 45 |
| 14N77-20-16 | 25 | 1 | -16 | 25,4 | 1 1/4 | 120 | 66 | 70 | 51 |
| 11977-16-20 | 31 | 1 1/4 | -20 | 31,8 | 1 | 156 | 92 | 90 | 45 |
| 14N77-20-20 | 31 | 1 1/4 | -20 | 31,8 | 1 1/4 | 156 | 92 | 90 | 51 |
| 14N77-24-20 | 31 | 1 1/4 | -20 | 31,8 | 1 1/2 | 156 | 92 | 90 | 60 |
| 14N77-24-24 | 38 | 1 1/2 | -24 | 38,1 | 1 1/2 | 180 | 113 | 104 | 60 |
| 14N77-32-24 | 38 | 1 1/2 | -24 | 38,1 | 2 | 180 | 113 | 104 | 71 |
| 14N77-32-32 | 51 | 2 | -32 | 50,8 | 2 | 206 | 129 | 138 | 71 |

SAE flange halves see in section Eb.

Fittings with standard O-ring seals can be used for temperatures from -40 °C up to +105 °C.
O-rings see section Eb. Special O-rings are available on request.

Approved **fitting series** for hose types, depending on size:

| | | | | | | | | | | | | | | | |
|-----------|--------|--------|-------|-----|-------|-------|-----|-------|-------|-----|-------|-------|-------|------|-----|
| 77 | 387 | 387ST | 387TC | 487 | 487ST | 487TC | 787 | 787TC | 787ST | 797 | 797TC | 797ST | 797RH | SX42 | ... |
| | SX42LT | SX42TC | | | | | | | | | | | | | |

6A ISO 6162-2-Flange Straight

ISO 12151-3-S-S – SFS
(42.0 MPa/ 6000 psi)

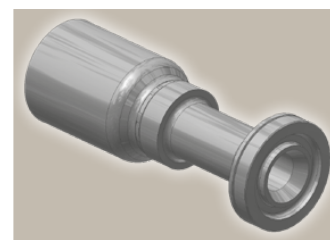
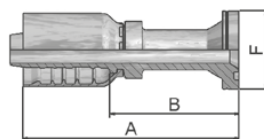

| Part Number | Hose I.D. | | | | Flange Inch | A mm | B mm | F mm |
|-------------|-----------|-------|------|------|----------------|---------|---------|---------|
| | DN | Inch | Size | mm | | | | |
| 16A77-8-8 | 12 | 1/2 | -8 | 12.7 | 1/2 | 89 | 55 | 32 |
| 16A77-12-8 | 12 | 1/2 | -8 | 12.7 | 3/4 | 69.4 | 34.75 | 41 |
| 16A77-12-10 | 16 | 5/8 | -10 | 15.9 | 3/4 | 75 | 36 | 41 |
| 16A77-16-10 | 16 | 5/8 | -10 | 15.9 | 1 | 80 | 41 | 48 |
| 16A77-8-12 | 19 | 3/4 | -12 | 19.1 | 1/2 | 106 | 60 | 32 |
| 16A77-12-12 | 19 | 3/4 | -12 | 19.1 | 3/4 | 114.2 | 68.2 | 41 |
| 16A77-16-12 | 19 | 3/4 | -12 | 19.1 | 1 | 88.2 | 42 | 48 |
| 16A77-20-12 | 19 | 3/4 | -12 | 19.1 | 1 1/4 | 93 | 47 | 54 |
| 16A77-12-16 | 25 | 1 | -16 | 25.4 | 3/4 | 126 | 72 | 41 |
| 16A77-16-16 | 25 | 1 | -16 | 25.4 | 1 | 113 | 59 | 48 |
| 16A77-20-16 | 25 | 1 | -16 | 25.4 | 1 1/4 | 103 | 49 | 54 |
| 16A77-16-20 | 31 | 1 1/4 | -20 | 31.8 | 1 | 145 | 82 | 48 |
| 16A77-20-20 | 31 | 1 1/4 | -20 | 31.8 | 1 1/4 | 146 | 82 | 54 |
| 16A77-24-20 | 31 | 1 1/4 | -20 | 31.8 | 1 1/2 | 118 | 55 | 64 |
| 16A77-20-24 | 38 | 1 1/2 | -24 | 38.1 | 1 1/4 | 154 | 87 | 54 |
| 16A77-24-24 | 38 | 1 1/2 | -24 | 38.1 | 1 1/2 | 162 | 96 | 64 |
| 16A77-32-24 | 38 | 1 1/2 | -24 | 38.1 | 2 | 133 | 66 | 79 |
| 16A77-32-32 | 51 | 2 | -32 | 50.8 | 2 | 183 | 105 | 79 |

SAE flange halves see in section Eb.

Fittings with standard O-ring seals can be used for temperatures from -40 °C up to +105 °C.
O-rings see section Eb. Special O-rings are available on request.

77 Series

Approved **fitting series** for hose types, depending on size:

| | | | | | | | | | | | | | | | |
|-----------|--------|-------|--------|-----|-------|-------|-----|-------|-------|-----|-------|-------|-------|------|-----|
| 77 | 387 | 387ST | 387TC | 487 | 487ST | 487TC | 787 | 787TC | 787ST | 797 | 797TC | 797ST | 797RH | SX42 | ... |
| | SX42LT | | SX42TC | | | | | | | | | | | | |



6E ISO 6162-2 Flange 30° Elbow

SFS 30°
(42.0 MPa/ 6000 psi)

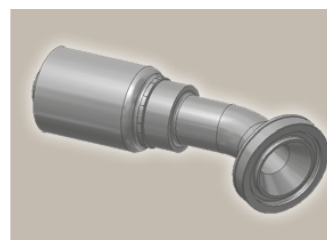
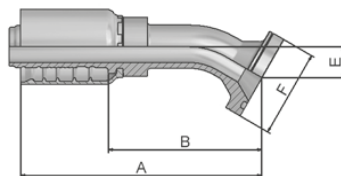

| Part Number | Hose I.D. | | | | Flange Inch | A mm | B mm | E mm | F mm |
|-------------|-----------|-------|------|------|----------------|---------|---------|---------|---------|
| | DN | Inch | Size | mm | | | | | |
| 16E77-12-12 | 19 | 3/4 | -12 | 19,1 | 3/4 | 121 | 75 | 16 | 41 |
| 16E77-16-12 | 19 | 3/4 | -12 | 19,1 | 1 | 122 | 76 | 16 | 48 |
| 16E77-16-16 | 25 | 1 | -16 | 25,4 | 1 | 136 | 82 | 19 | 48 |
| 16E77-20-16 | 25 | 1 | -16 | 25,4 | 1 1/4 | 149 | 95 | 19 | 54 |
| 16E77-20-20 | 31 | 1 1/4 | -20 | 31,8 | 1 1/4 | 175 | 111 | 24 | 54 |
| 16E77-24-24 | 38 | 1 1/2 | -24 | 38,1 | 1 1/2 | 190 | 123 | 30 | 64 |
| 16E77-32-32 | 51 | 2 | -32 | 50,8 | 2 | 223 | 145 | 32 | 79 |

SAE flange halves see in section Eb.

Fittings with standard O-ring seals can be used for temperatures from -40 °C up to +105 °C.

O-rings see section Eb. Special O-rings are available on request.

6F ISO 6162-2-Flange 45° Elbow – Heavy Series

ISO 12151-3 – E45-S – SFS 45°
(42.0 MPa/ 6000 psi)

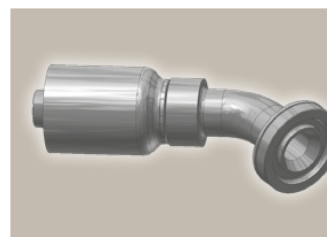
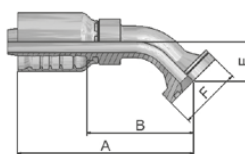

| Part Number | Hose I.D. | | | | Flange Inch | A mm | B mm | E mm | F mm |
|-------------|-----------|-------|------|------|----------------|---------|---------|---------|---------|
| | DN | Inch | Size | mm | | | | | |
| 16F77-8-8 | 12 | 1/2 | -8 | 12,7 | 1/2 | 79 | 44 | 19 | 32 |
| 16F77-12-8 | 12 | 1/2 | -8 | 12,7 | 3/4 | 85,8 | 51 | 26 | 41 |
| 16F77-8-10 | 16 | 5/8 | -10 | 15,9 | 1/2 | 105 | 66 | 26 | 32 |
| 16F77-12-10 | 16 | 5/8 | -10 | 15,9 | 3/4 | 104 | 66 | 26 | 41 |
| 16F77-16-10 | 16 | 5/8 | -10 | 15,9 | 1 | 105 | 66 | 26 | 48 |
| 16F77-12-12 | 19 | 3/4 | -12 | 19,1 | 3/4 | 116,2 | 70 | 26 | 41 |
| 16F77-16-12 | 19 | 3/4 | -12 | 19,1 | 1 | 116 | 70 | 26 | 48 |
| 16F77-12-16 | 25 | 1 | -16 | 25,4 | 3/4 | 132 | 78 | 32 | 41 |
| 16F77-16-16 | 25 | 1 | -16 | 25,4 | 1 | 141 | 87 | 32 | 48 |
| 16F77-20-16 | 25 | 1 | -16 | 25,4 | 1 1/4 | 142 | 88 | 32 | 54 |
| 16F77-16-20 | 31 | 1 1/4 | -20 | 31,8 | 1 | 154 | 90 | 38 | 48 |
| 16F77-20-20 | 31 | 1 1/4 | -20 | 31,8 | 1 1/4 | 167 | 104 | 38 | 54 |
| 16F77-24-20 | 31 | 1 1/4 | -20 | 31,8 | 1 1/2 | 173 | 110 | 44 | 64 |
| 16F77-20-24 | 38 | 1 1/2 | -24 | 38,1 | 1 1/4 | 184 | 117 | 44 | 54 |
| 16F77-24-24 | 38 | 1 1/2 | -24 | 38,1 | 1 1/2 | 192 | 125 | 44 | 64 |
| 16F77-32-24 | 38 | 1 1/2 | -24 | 38,1 | 2 | 192 | 125 | 44 | 79 |
| 16F77-32-32 | 51 | 2 | -32 | 50,8 | 2 | 218 | 141 | 56 | 79 |

SAE flange halves see in section Eb.

Fittings with standard O-ring seals can be used for temperatures from -40 °C up to +105 °C.

O-rings see section Eb. Special O-rings are available on request.

Approved **fitting series** for hose types, depending on size:

| | | | | | | | | | | | | | | | |
|-----------|--------|--------|-------|-----|-------|-------|-----|-------|-------|-----|-------|-------|-------|------|-----|
| 77 | 387 | 387ST | 387TC | 487 | 487ST | 487TC | 787 | 787TC | 787ST | 797 | 797TC | 797ST | 797RH | SX42 | ... |
| | SX42LT | SX42TC | | | | | | | | | | | | | |

6N ISO 6162-2-Flange 90° Elbow

ISO 12151-3 – E-S – SFS 90°
(42.0 MPa/ 6000 psi)

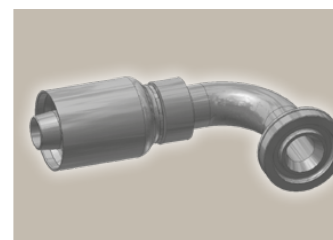
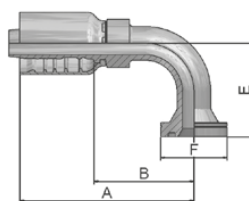

| Part Number | Hose I.D. | | | | Flange Inch | A mm | B mm | E mm | F mm |
|-------------|-----------|-------|------|------|----------------|---------|---------|---------|---------|
| | DN | Inch | Size | mm | | | | | |
| 16N77-8-8 | 12 | 1/2 | -8 | 12.7 | 1/2 | 76 | 41 | 41 | 32 |
| 16N77-12-8 | 12 | 1/2 | -8 | 12.7 | 3/4 | 81.05 | 47 | 45 | 41 |
| 16N77-8-10 | 16 | 5/8 | -10 | 15.9 | 1/2 | 92 | 53 | 54 | 32 |
| 16N77-12-10 | 16 | 5/8 | -10 | 15.9 | 3/4 | 92 | 53 | 54 | 41 |
| 16N77-16-10 | 16 | 5/8 | -10 | 15.9 | 1 | 92 | 53 | 54 | 48 |
| 16N77-12-12 | 19 | 3/4 | -12 | 19.1 | 3/4 | 108.2 | 62 | 58 | 41 |
| 16N77-16-12 | 19 | 3/4 | -12 | 19.1 | 1 | 108 | 62 | 58 | 48 |
| 16N77-20-12 | 19 | 3/4 | -12 | 19.1 | 1 1/4 | 108 | 62 | 63 | 54 |
| 16N77-12-16 | 25 | 1 | -16 | 25.4 | 3/4 | 115 | 61 | 70 | 41 |
| 16N77-16-16 | 25 | 1 | -16 | 25.4 | 1 | 120 | 66 | 70 | 48 |
| 16N77-20-16 | 25 | 1 | -16 | 25.4 | 1 1/4 | 135 | 81 | 70 | 54 |
| 16N77-16-20 | 31 | 1 1/4 | -20 | 31.8 | 1 | 138 | 75 | 90 | 48 |
| 16N77-20-20 | 31 | 1 1/4 | -20 | 31.8 | 1 1/4 | 156 | 92 | 90 | 54 |
| 16N77-24-20 | 31 | 1 1/4 | -20 | 31.8 | 1 1/2 | 151 | 87 | 90 | 64 |
| 16N77-20-24 | 38 | 1 1/2 | -24 | 38.1 | 1 1/4 | 156 | 89 | 104 | 54 |
| 16N77-24-24 | 38 | 1 1/2 | -24 | 38.1 | 1 1/2 | 180 | 113 | 104 | 64 |
| 16N77-32-24 | 38 | 1 1/2 | -24 | 38.1 | 2 | 175 | 108 | 104 | 79 |
| 16N77-32-32 | 51 | 2 | -32 | 50.8 | 2 | 223 | 138 | 138 | 79 |

SAE flange halves see in section Eb.

Fittings with standard O-ring seals can be used for temperatures from -40 °C up to +105 °C.
O-rings see section Eb. Special O-rings are available on request.

77 Series

Approved **fitting series** for hose types, depending on size:

| | | | | | | | | | | | | | | | |
|-----------|--------|--------|-------|-----|-------|-------|-----|-------|-------|-----|-------|-------|-------|------|-----|
| 77 | 387 | 387ST | 387TC | 487 | 487ST | 487TC | 787 | 787TC | 787ST | 797 | 797TC | 797ST | 797RH | SX42 | ... |
| | SX42LT | SX42TC | | | | | | | | | | | | | |



X5 Flange – Straight

Full flange system for
ISO 6162-1 or ISO 6162-2

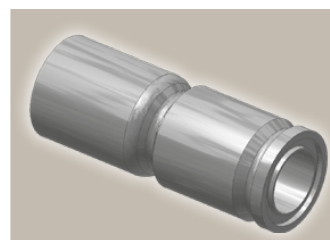
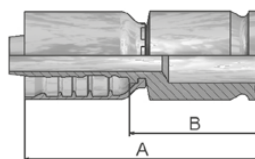

| Part Number | Hose I.D. | | | | Flange Inch | A mm | B mm |
|-------------|-----------|-------|------|------|----------------|---------|---------|
| | DN | Inch | Size | mm | | | |
| 1X577-12-12 | 19 | 3/4 | -12 | 19,1 | 3/4 | 103 | 57 |
| 1X577-16-12 | 19 | 3/4 | -12 | 19,1 | 1 | 103 | 57 |
| 1X577-16-16 | 25 | 1 | -16 | 25,4 | 1 | 113 | 59 |
| 1X577-20-16 | 25 | 1 | -16 | 25,4 | 1 1/4 | 113 | 59 |
| 1X577-20-20 | 31 | 1 1/4 | -20 | 31,8 | 1 1/4 | 124 | 57 |
| 1X577-24-24 | 38 | 1 1/2 | -24 | 38,1 | 1 1/2 | 129 | 62 |
| 1X577-32-32 | 51 | 2 | -32 | 50,8 | 2 | 154 | 77 |

Full flange system see Eb-4.

X7 Flange – 45° Elbow

Full flange system for
ISO 6162-1 or ISO 6162-2

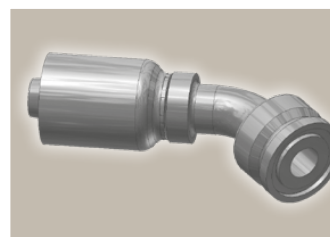
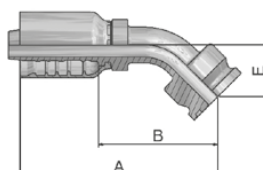

| Part Number | Hose I.D. | | | | Flange Inch | A mm | B mm | E mm |
|-------------|-----------|-------|------|------|----------------|---------|---------|---------|
| | DN | Inch | Size | mm | | | | |
| 1X777-12-12 | 19 | 3/4 | -12 | 19,1 | 3/4 | 119 | 73 | 29 |
| 1X777-16-12 | 19 | 3/4 | -12 | 19,1 | 1 | 118 | 72 | 29 |
| 1X777-16-16 | 25 | 1 | -16 | 25,4 | 1 | 141 | 87 | 32 |
| 1X777-20-16 | 25 | 1 | -16 | 25,4 | 1 1/4 | 147 | 93 | 38 |
| 1X777-16-20 | 31 | 1 1/4 | -20 | 31,8 | 1 | 146 | 82 | 38 |
| 1X777-20-20 | 31 | 1 1/4 | -20 | 31,8 | 1 1/4 | 159 | 96 | 38 |
| 1X777-24-20 | 31 | 1 1/4 | -20 | 31,8 | 1 1/2 | 165 | 102 | 44 |
| 1X777-24-24 | 38 | 1 1/2 | -24 | 38,1 | 1 1/2 | 183 | 116 | 45 |

Full flange system see Eb-4.

Approved **fitting series** for hose types, depending on size:

| | | | | | | | | | | | | | | | |
|-----------|--------|--------|-------|-----|-------|-------|-----|-------|-------|-----|-------|-------|-------|------|-----|
| 77 | 387 | 387ST | 387TC | 487 | 487ST | 487TC | 787 | 787TC | 787ST | 797 | 797TC | 797ST | 797RH | SX42 | ... |
| | SX42LT | SX42TC | | | | | | | | | | | | | |

X9 Flange – 90° Elbow

Full flange system for
ISO 6162-1 or ISO 6162-2

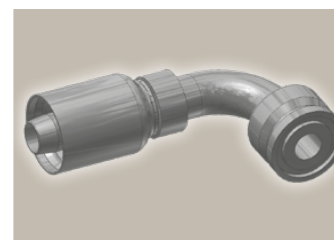
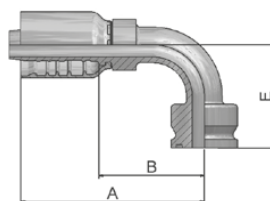

| Part Number | Hose I.D. | | | | Flange Inch | A mm | B mm | E mm |
|-------------|-----------|-------|------|------|----------------|---------|---------|---------|
| | DN | Inch | Size | mm | | | | |
| 1X977-8-8 | 12 | 1/2 | -8 | 12,7 | 1/2 | 81 | 45 | 43 |
| 1X977-12-12 | 19 | 3/4 | -12 | 19,1 | 3/4 | 108 | 62 | 61 |
| 1X977-16-12 | 19 | 3/4 | -12 | 19,1 | 1 | 108 | 62 | 61 |
| 1X977-12-16 | 25 | 1 | -16 | 25,4 | 3/4 | 110 | 56 | 70 |
| 1X977-16-16 | 25 | 1 | -16 | 25,4 | 1 | 131 | 77 | 70 |
| 1X977-20-16 | 25 | 1 | -16 | 25,4 | 1 1/4 | 131 | 77 | 70 |
| 1X977-16-20 | 31 | 1 1/4 | -20 | 31,8 | 1 | 130 | 67 | 90 |
| 1X977-20-20 | 31 | 1 1/4 | -20 | 31,8 | 1 1/4 | 148 | 84 | 90 |
| 1X977-24-20 | 31 | 1 1/4 | -20 | 31,8 | 1 1/2 | 148 | 84 | 90 |
| 1X977-24-24 | 38 | 1 1/2 | -24 | 38,1 | 1 1/2 | 180 | 113 | 104 |
| 1X977-32-32 | 51 | 2 | -32 | 50,8 | 2 | 221 | 144 | 138 |

Full flange system see Eb-4.

XA Caterpillar® Flange Straight

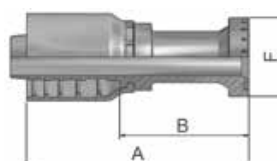

| Part Number | Hose I.D. | | | | Flange Inch | A mm | B mm | F mm |
|-------------|-----------|-------|------|------|----------------|---------|---------|---------|
| | DN | Inch | Size | mm | | | | |
| 1XA77-12-12 | 19 | 3/4 | -12 | 19,1 | 3/4 | 114 | 68 | 41 |
| 1XA77-16-12 | 19 | 3/4 | -12 | 19,1 | 3/4 | 88 | 42 | 48 |
| 1XA77-16-16 | 25 | 1 | -16 | 25,4 | 1 | 141 | 87 | 48 |
| 1XA77-20-16 | 25 | 1 | -16 | 25,4 | 1 | 104 | 50 | 54 |
| 1XA77-20-20 | 31 | 1 1/4 | -20 | 31,8 | 1 1/4 | 152 | 88 | 54 |
| 1XA77-24-20 | 31 | 1 1/4 | -20 | 31,8 | 1 1/2 | 121 | 57 | 64 |
| 1XA77-24-24 | 38 | 1 1/2 | -24 | 38,1 | 1 1/2 | 176 | 109 | 64 |
| 1XA77-32-24 | 38 | 1 1/2 | -24 | 38,1 | 2 | 133 | 66 | 79 |
| 1XA77-32-32 | 51 | 2 | -32 | 50,8 | 2 | 192 | 115 | 79 |

77 Series

Approved **fitting series** for hose types, depending on size:

| | | | | | | | | | | | | | | | |
|-----------|--------|--------|-------|-----|-------|-------|-----|-------|-------|-----|-------|-------|-------|------|-----|
| 77 | 387 | 387ST | 387TC | 487 | 487ST | 487TC | 787 | 787TC | 787ST | 797 | 797TC | 797ST | 797RH | SX42 | ... |
| | SX42LT | SX42TC | | | | | | | | | | | | | |

XF Caterpillar® Flange
45° Elbow

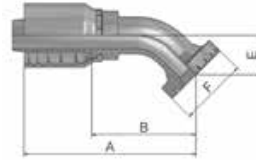

| Part Number | Hose I.D. | | | | Flange Inch | A mm | B mm | E mm | F mm |
|-------------|-----------|-------|------|------|----------------|---------|---------|---------|---------|
| | DN | Inch | Size | mm | | | | | |
| 1XF77-12-12 | 19 | 3/4 | -12 | 19,1 | 3/4 | 122 | 76 | 31 | 41 |
| 1XF77-16-16 | 25 | 1 | -16 | 25,4 | 1 | 145 | 91 | 36 | 48 |
| 1XF77-20-20 | 31 | 1 1/4 | -20 | 31,8 | 1 1/4 | 166 | 103 | 37 | 54 |
| 1XF77-24-20 | 31 | 1 1/4 | -20 | 31,8 | 1 1/2 | 166 | 103 | 37 | 64 |

XG Caterpillar® Flange
60° Elbow

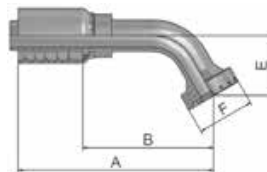

| Part Number | Hose I.D. | | | | Flange Inch | A mm | B mm | E mm | F mm |
|-------------|-----------|-------|------|------|----------------|---------|---------|---------|---------|
| | DN | Inch | Size | mm | | | | | |
| 1XG77-12-12 | 19 | 3/4 | -12 | 19,1 | 3/4 | 137 | 91 | 42 | 41 |
| 1XG77-16-16 | 25 | 1 | -16 | 25,4 | 1 | 163 | 109 | 50 | 48 |
| 1XG77-20-20 | 31 | 1 1/4 | -20 | 31,8 | 1 1/4 | 205 | 141 | 51 | 54 |

Approved **fitting series** for hose types, depending on size:

| | | | | | | | | | | | | | | | |
|-----------|--------|--------|-------|-----|-------|-------|-----|-------|-------|-----|-------|-------|-------|------|-----|
| 77 | 387 | 387ST | 387TC | 487 | 487ST | 487TC | 787 | 787TC | 787ST | 797 | 797TC | 797ST | 797RH | SX42 | ... |
| | SX42LT | SX42TC | | | | | | | | | | | | | |



XN Caterpillar® Flange 90° Elbow

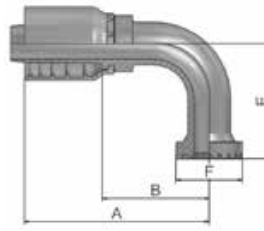

| Part Number | Hose I.D. | | | | Flange | A mm | B mm | E mm | F mm |
|-------------|---------------|-------|------|------|------------|---------|---------|---------|---------|
| | DN | Inch | Size | mm | | | | | |
| 1XN77-12-12 | 19 | 3/4 | -12 | 19,1 | 3/4 | 108 | 62 | 63 | 41 |
| 1XN77-16-12 | 19 | 3/4 | -12 | 19,1 | 1 | 108 | 62 | 63 | 48 |
| 1XN77-16-16 | 25 | 1 | -16 | 25,4 | 1 | 131 | 77 | 74 | 48 |
| 1XN77-20-16 | 25 | 1 | -16 | 25,4 | 1 1/4 | 131 | 77 | 74 | 54 |
| 1XN77-20-20 | 31 | 1 1/4 | -20 | 31,8 | 1 1/4 | 156 | 92 | 94 | 54 |
| 1XN77-24-20 | 31 | 1 1/4 | -20 | 31,8 | 1 1/2 | 156 | 92 | 77 | 64 |
| 1XN77-24-24 | 38 | 1 1/2 | -24 | 38,1 | 1 1/2 | 160 | 103 | 106 | 79 |
| 1XN77-32-24 | 38 | 1 1/2 | -24 | 38,1 | 2 | 169 | 103 | 106 | 79 |

K5 Komatsu® Flange Straight

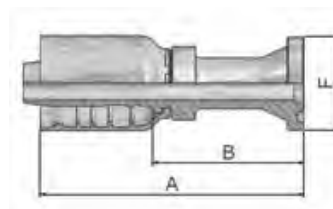

| Part Number | Hose I.D. | | | | A mm | B mm |
|-------------|---------------|------|------|------|---------|---------|
| | DN | Inch | Size | mm | | |
| 1K577-16-16 | 25 | 1 | -16 | 25,4 | 119 | 65 |

77 Series

Approved **fitting series** for hose types, depending on size:

| | | | | | | | | | | | | | | | |
|-----------|--------|--------|-------|-----|-------|-------|-----|-------|-------|-----|-------|-------|-------|------|-----|
| 77 | 387 | 387ST | 387TC | 487 | 487ST | 487TC | 787 | 787TC | 787ST | 797 | 797TC | 797ST | 797RH | SX42 | ... |
| | SX42LT | SX42TC | | | | | | | | | | | | | |

K7 Komatsu® Flange 45° Elbow

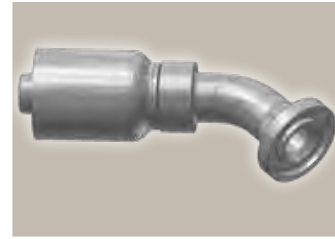
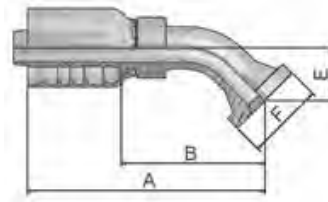

| Part Number | Hose I.D. | | | | A mm | B mm | E mm |
|-------------|-----------|-------|------|------|---------|---------|---------|
| | DN | Inch | Size | mm | | | |
| 1K777-12-12 | 19 | 3/4 | -12 | 19,1 | 116 | 70 | 26 |
| 1K777-16-16 | 25 | 1 | -16 | 25,4 | 143 | 89 | 32 |
| 1K777-20-20 | 31 | 1 1/4 | -20 | 31,8 | 159 | 96 | 38 |

K9 Komatsu® Flange 90° Elbow

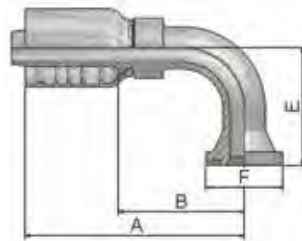

| Part Number | Hose I.D. | | | | A mm | B mm | E mm |
|-------------|-----------|-------|------|------|---------|---------|---------|
| | DN | Inch | Size | mm | | | |
| 1K977-12-12 | 19 | 3/4 | -12 | 19,1 | 108 | 62 | 58 |
| 1K977-16-16 | 25 | 1 | -16 | 25,4 | 127 | 73 | 70 |
| 1K977-20-20 | 31 | 1 1/4 | -20 | 31,8 | 148 | 84 | 90 |

Approved **fitting series** for hose types, depending on size:

| | | | | | | | | | | | | | | | |
|-----------|--------|-------|--------|-----|-------|-------|-----|-------|-------|-----|-------|-------|-------|------|-----|
| 77 | 387 | 387ST | 387TC | 487 | 487ST | 487TC | 787 | 787TC | 787ST | 797 | 797TC | 797ST | 797RH | SX42 | ... |
| | SX42LT | | SX42TC | | | | | | | | | | | | |



JC Female ORFS Swivel – Straight Short

ISO 12151-1 – SWSA
SAE J516 – ORFS

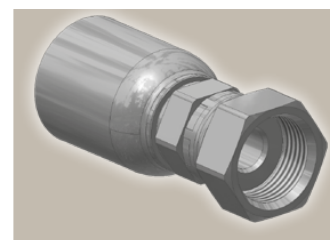
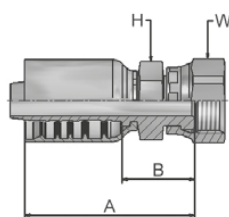

| Part Number | Hose I.D. | | | | Thread UNF | A mm | B mm | H mm | W mm |
|-------------|-----------|-------|------|------|---------------|---------|---------|---------|---------|
| | DN | Inch | Size | mm | | | | | |
| 1JC77-8-8 | 12 | 1/2 | -8 | 12,7 | 13/16x16 | 60 | 25 | 22 | 24 |
| 1JC77-10-8 | 12 | 1/2 | -8 | 12,7 | 1x14 | 65 | 31 | 24 | 30 |
| 1JC77-12-8 | 12 | 1/2 | -8 | 12,7 | 1 3/16x12 | 64 | 29 | 30 | 36 |
| 1JC77-10-10 | 16 | 5/8 | -10 | 15,9 | 1x14 | 70 | 31 | 24 | 30 |
| 1JC77-12-10 | 16 | 5/8 | -10 | 15,9 | 1 3/16x16 | 69 | 30 | 30 | 36 |
| 1JC77-10-12 | 19 | 3/4 | -12 | 19,1 | 1x14 | 79 | 33 | 30 | 30 |
| 1JC77-12-12 | 19 | 3/4 | -12 | 19,1 | 1 3/16x12 | 79 | 33 | 30 | 36 |
| 1JC77-16-12 | 19 | 3/4 | -12 | 19,1 | 1 7/16x12 | 81 | 35,3 | 36 | 41 |
| 1JC77-12-16 | 25 | 1 | -16 | 25,4 | 1 3/16x12 | 92 | 38 | 36 | 36 |
| 1JC77-16-16 | 25 | 1 | -16 | 25,4 | 1 7/16x12 | 91 | 37,1 | 36 | 41 |
| 1JC77-20-16 | 25 | 1 | -16 | 25,4 | 1 11/16x12 | 90 | 36 | 41 | 50 |
| 1JC77-20-20 | 31 | 1 1/4 | -20 | 31,8 | 1 11/16x12 | 107 | 44 | 46 | 50 |
| 1JC77-24-24 | 38 | 1 1/2 | -24 | 38,1 | 2x12 | 109 | 43 | 50 | 60 |
| 1JC77-32-32 | 51 | 2 | -32 | 50,8 | 2 1/2x12 | 143 | 66 | 65 | 75 |

J7 Female ORFS – Swivel 45° Elbow

ISO 12151-1 – SWE 45°
SAE J516 – ORFS 45°

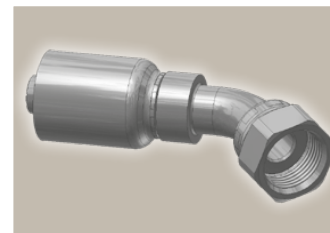
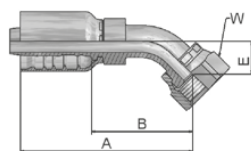

| Part Number | Hose I.D. | | | | Thread UNF | A mm | B mm | E mm | W mm |
|-------------|-----------|-------|------|------|---------------|---------|---------|---------|---------|
| | DN | Inch | Size | mm | | | | | |
| 1J777-8-8 | 12 | 1/2 | -8 | 12,7 | 13/16x16 | 72,7 | 38 | 15 | 24 |
| 1J777-10-10 | 16 | 5/8 | -10 | 15,9 | 1x14 | 86 | 47 | 16 | 30 |
| 1J777-12-10 | 16 | 5/8 | -10 | 15,9 | 1 3/16x12 | 98 | 59 | 21 | 36 |
| 1J777-12-12 | 19 | 3/4 | -12 | 19,1 | 1 3/16x12 | 111 | 65 | 21 | 36 |
| 1J777-16-12 | 19 | 3/4 | -12 | 19,1 | 1 7/16x12 | 114 | 68 | 24 | 41 |
| 1J777-16-16 | 25 | 1 | -16 | 25,4 | 1 7/16x12 | 133 | 79 | 24 | 41 |
| 1J777-20-20 | 31 | 1 1/4 | -20 | 31,8 | 1 11/16x12 | 145 | 81 | 25 | 50 |
| 1J777-24-20 | 31 | 1 1/4 | -20 | 31,8 | 2x12 | 148 | 84 | 27 | 60 |
| 1J777-24-24 | 38 | 1 1/2 | -24 | 38,1 | 2x12 | 176 | 109 | 42 | 60 |

77 Series

Approved **fitting series** for hose types, depending on size:

| | | | | | | | | | | | | | | | |
|-----------|--------|--------|-------|-----|-------|-------|-----|-------|-------|-----|-------|-------|-------|------|-----|
| 77 | 387 | 387ST | 387TC | 487 | 487ST | 487TC | 787 | 787TC | 787ST | 797 | 797TC | 797ST | 797RH | SX42 | ... |
| | SX42LT | SX42TC | | | | | | | | | | | | | |



J9 Female ORFS – Swivel 90° Elbow – Short Drop

ISO 12151-1 – SWES
SAE J516 – ORFS 90°

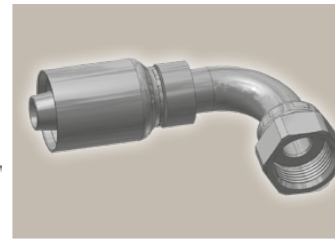
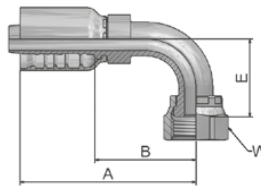

| Part Number | Hose I.D. | | | | Thread UNF | A mm | B mm | E mm | W mm |
|-------------|-----------|-------|------|------|---------------|---------|---------|---------|---------|
| | DN | Inch | Size | mm | | | | | |
| 1J977-8-8 | 12 | 1/2 | -8 | 12,7 | 13/16x16 | 70,65 | 36 | 29 | 24 |
| 1J977-10-10 | 16 | 5/8 | -10 | 15,9 | 1x14 | 97 | 50 | 32 | 30 |
| 1J977-12-10 | 16 | 5/8 | -10 | 15,9 | 1 3/16x12 | 89 | 50 | 48 | 36 |
| 1J977-10-12 | 19 | 3/4 | -12 | 19,1 | 1x14 | 97 | 51 | 32 | 30 |
| 1J977-12-12 | 19 | 3/4 | -12 | 19,1 | 1 3/16x12 | 108 | 62 | 48 | 36 |
| 1J977-16-12 | 19 | 3/4 | -12 | 19,1 | 1 7/16x12 | 108 | 62 | 56 | 41 |
| 1J977-16-16 | 25 | 1 | -16 | 25,4 | 1 7/16x12 | 131 | 77 | 56 | 41 |
| 1J977-20-20 | 31 | 1 1/4 | -20 | 31,8 | 1 11/16x12 | 146 | 82 | 64 | 50 |
| 1J977-24-24 | 38 | 1 1/2 | -24 | 38,1 | 2x12 | 163 | 96 | 69 | 60 |

J1 Female ORFS – Swivel 90° Elbow – Long Drop

ISO 12151-1 – SWEL
SAE J 516 – ORFS 90° L

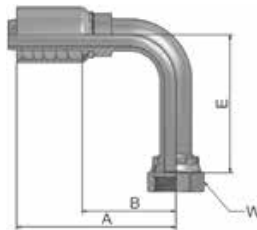

| Part Number | Hose I.D. | | | | Thread UNF | A mm | B mm | E mm | W mm |
|-------------|-----------|------|------|------|---------------|---------|---------|---------|---------|
| | DN | Inch | Size | mm | | | | | |
| 1J177-12-12 | 19 | 3/4 | -12 | 19,1 | 1 3/16x12 | 108 | 62 | 96 | 36 |
| 1J177-16-16 | 25 | 1 | -16 | 25,4 | 1 7/16x12 | 131 | 77 | 114 | 41 |

Approved **fitting series** for hose types, depending on size:

| | | | | | | | | | | | | | | | |
|-----------|--------|-------|--------|-----|-------|-------|-----|-------|-------|-----|-------|-------|-------|------|-----|
| 77 | 387 | 387ST | 387TC | 487 | 487ST | 487TC | 787 | 787TC | 787ST | 797 | 797TC | 797ST | 797RH | SX42 | ... |
| | SX42LT | | SX42TC | | | | | | | | | | | | |

JM

ORFS Male

ISO 12151-1-S – SAE J516

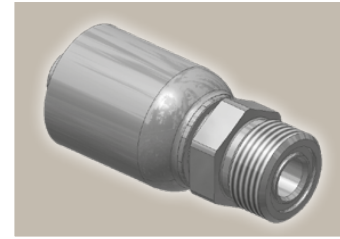
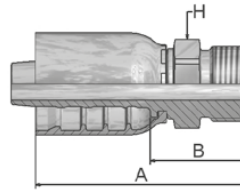

| Part Number | Hose I.D. | | | | Thread UNF | A mm | B mm | H mm |
|-------------|-----------|-------|------|------|---------------|---------|---------|---------|
| | DN | Inch | Size | mm | | | | |
| 1JM77-8-8 | 12 | 1/2 | -8 | 12,7 | 13/16x16 | 66 | 32 | 22 |
| 1JM77-12-8 | 12 | 1/2 | -8 | 12,7 | 1 3/16x12 | 75 | 40 | 32 |
| 1JM77-10-10 | 16 | 5/8 | -10 | 15,9 | 1x14 | 76 | 37 | 27 |
| 1JM77-12-10 | 16 | 5/8 | -10 | 15,9 | 1 3/16x12 | 79 | 40 | 32 |
| 1JM77-12-12 | 19 | 3/4 | -12 | 19,1 | 1 3/16x12 | 89 | 43 | 32 |
| 1JM77-16-12 | 19 | 3/4 | -12 | 19,1 | 1 7/16x12 | 93 | 47 | 41 |
| 1JM77-16-16 | 25 | 1 | -16 | 25,4 | 1 7/16x12 | 96 | 40,9 | 41 |
| 1JM77-20-16 | 25 | 1 | -16 | 25,4 | 1 11/16x12 | 93 | 39,2 | 46 |
| 1JM77-20-20 | 31 | 1 1/4 | -20 | 31,8 | 1 11/16x12 | 110 | 46 | 46 |
| 1JM77-24-20 | 31 | 1 1/4 | -20 | 31,8 | 2 12 | 116 | 52 | 55 |

JM fittings are supplied without O-ring.
Find O-rings in section E. Special O-rings are available on request.

77 Series

Approved **fitting series** for hose types, depending on size:

| | | | | | | | | | | | | | | | |
|-----------|--------|--------|-------|-----|-------|-------|-----|-------|-------|-----|-------|-------|-------|------|-----|
| 77 | 387 | 387ST | 387TC | 487 | 487ST | 487TC | 787 | 787TC | 787ST | 797 | 797TC | 797ST | 797RH | SX42 | ... |
| | SX42LT | SX42TC | | | | | | | | | | | | | |

High Pressure
French Standard

Parkrimp No-Skive Fittings
77 Series

FG Male French Gas Series
Rigid – Straight (24° Cone)

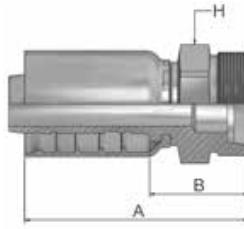

| Part Number | Hose I.D. | | | | Thread metric | A mm | B mm | H mm |
|-------------|-----------|------|------|------|------------------|---------|---------|---------|
| | DN | Inch | Size | mm | | | | |
| 1FG77-27-12 | 19 | 3/4 | -12 | 19.1 | M36x1.5 | 82 | 36 | 36 |
| 1FG77-33-16 | 25 | 1 | -16 | 25.4 | M45x1.5 | 97 | 43 | 46 |

Approved **fitting series** for hose types, depending on size:

| | | | | | | | | | | | | | | | |
|-----------|--------|-------|--------|-----|-------|-------|-----|-------|-------|-----|-------|-------|-------|------|-----|
| 77 | 387 | 387ST | 387TC | 487 | 487ST | 487TC | 787 | 787TC | 787ST | 797 | 797TC | 797ST | 797RH | SX42 | ... |
| | SX42LT | | SX42TC | | | | | | | | | | | | |



Dd-24

Catalogue 4400/UK

Large range of special hose fittings for the MRO market

The demand for special hose fittings is part of our everyday business. In order to meet this demand with the authority expected, the Polymer Hose Division Europe has extended its standard offer with special hose fittings such as an extra drop length, etc.

The following is an overview of our special hose fitting selection:

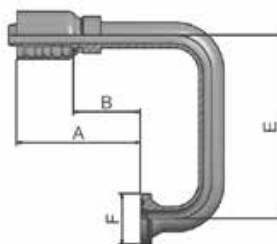

Further special hose fittings are available on request.

| Part Number | Description | Hose I.D. Size | Flange Inch | A mm | B mm | E mm | F mm |
|--------------------------|----------------------------------------------|-------------------|----------------|---------|---------|---------|---------|
| 11977-12-12-SL100 | SAE 5000 psi 90° elbow - drop length 100 mm | -12 | 3/4 | 108 | 62 | 100 | 38 |
| 11977-12-12-SL150 | SAE 5000 psi 90° elbow - drop length 150 mm | -12 | 3/4 | 108 | 62 | 150 | 38 |
| 11977-16-12-SL100 | SAE 5000 psi 90° elbow - drop length 100 mm | -12 | 1 | 108 | 62 | 100 | 45 |
| 11977-16-12-SL150 | SAE 5000 psi 90° elbow - drop length 150 mm | -12 | 1 | 108 | 62 | 150 | 45 |
| 11977-16-16-SL150 | SAE 5000 psi 90° elbow - drop length 150 mm | -16 | 1 | 131 | 77 | 150 | 45 |
| 14N77-24-24-SL150 | SAE 5000 psi 90° elbow - drop length 150 mm | -24 | 1 1/2 | 175 | 108 | 150 | 60 |
| 16A77-20-20-RL186 | SAE 6000 psi - straight - Special | -20 | 1 1/4 | 175 | 112 | | 54 |
| 16F77-12-16-STB10 | SAE 6000 psi - 10° elbow | -16 | 3/4 | 143 | 89 | 6 | 41 |
| 16F77-20-16-RL110 | SAE 6000 psi - 45° elbow - Special | -16 | 1 1/4 | 164 | 110 | 32 | 54 |
| 16N77-12-12-SL100 | SAE 6000 psi 90° elbow - drop length 100 mm | -12 | 3/4 | 108 | 62 | 100 | 41 |
| 16N77-12-12-SL230 | SAE 6000 psi 90° elbow - drop length 230 mm | -12 | 3/4 | 108 | 62 | 230 | 41 |
| 16N77-12-12-SL72 | SAE 6000 psi 90° elbow - drop length 72 mm | -12 | 3/4 | 108 | 62 | 72 | 41 |
| 16N77-12-12-SL85 | SAE 6000 psi 90° elbow - drop length 85 mm | -12 | 3/4 | 108 | 62 | 85 | 41 |
| 16N77-12-12-STB115 | SAE 6000 psi - 115° elbow | -12 | 3/4 | 116 | 70 | 72 | 41 |
| 16N77-12-12-STB180 | SAE 6000 psi - 180° elbow | -12 | 3/4 | 101 | 55 | 150 | 41 |
| 16N77-12-16-SL55 | SAE 6000 psi 90° elbow - drop length 85 mm | -16 | 3/4 | 118 | 64 | 55 | 41 |
| 16N77-12-16-SL95 | SAE 6000 psi 90° elbow - drop length 95 mm | -16 | 3/4 | 118 | 64 | 95 | 41 |
| 16N77-16-16-SL100 | SAE 6000 psi 90° elbow - drop length 100 mm | -16 | 1 | 131 | 77 | 100 | 48 |
| 16N77-16-16-SL110 | SAE 6000 psi 90° elbow - drop length 110 mm | -16 | 1 | 131 | 77 | 110 | 48 |
| 16N77-16-16-SL120 | SAE 6000 psi 90° elbow - drop length 120 mm | -16 | 1 | 131 | 77 | 120 | 48 |
| 16N77-16-16-SL150 | SAE 6000 psi 90° elbow - drop length 150 mm | -16 | 1 | 131 | 77 | 150 | 48 |
| 16N77-16-16-SL175 | SAE 6000 psi 90° elbow - drop length 175 mm | -16 | 1 | 135 | 81 | 175 | 48 |
| 16N77-16-16-STB120 | SAE 6000 psi 120° elbow | -16 | 1 | 110 | 56 | 85 | 48 |
| 16N77-16-16-STB63-SL75 | SAE 6000 psi 63° elbow - drop length 75 mm | -16 | 1 | 167 | 113 | 75 | 48 |
| 16N77-20-16-SL120 | SAE 6000 psi 90° elbow - drop length 120 mm | -16 | 1 1/4 | 135 | 81 | 120 | 54 |
| 16N77-20-16-SL130 | SAE 6000 psi 90° elbow - drop length 130 mm | -16 | 1 1/4 | 135 | 81 | 130 | 54 |
| 16N77-20-16-STB110-SL150 | SAE 6000 psi 110° elbow - drop length 150 mm | -16 | 1 1/4 | 128 | 74 | 150 | 54 |
| 16N77-20-16-STB70-SL70 | SAE 6000 psi 70° elbow - drop length 70 mm | -16 | 1 1/4 | 157 | 103 | 70 | 54 |
| 16N77-20-20-SL115-RL220 | SAE 6000 psi 90° elbow - drop length 220 mm | -20 | 1 1/4 | 220 | 156 | 115 | 54 |
| 16N77-20-20-SL120 | SAE 6000 psi 90° elbow - drop length 120 mm | -20 | 1 1/4 | 151 | 87 | 120 | 54 |
| 16N77-20-20-SL150-RL150 | SAE 6000 psi 90° elbow - drop length 150 mm | -20 | 1 1/4 | 238 | 175 | 150 | 54 |
| 16N77-20-20-SL150-RL220 | SAE 6000 psi 90° elbow - drop length 150 mm | -20 | 1 1/4 | 220 | 156 | 150 | 54 |
| 16N77-20-20-SL195-RL320 | SAE 6000 psi 90° elbow - drop length 195 mm | -20 | 1 1/4 | 320 | 256 | 195 | 54 |
| 16N77-20-20-SL230-RL250 | SAE 6000 psi 90° elbow - drop length 230 mm | -20 | 1 1/4 | 338 | 275 | 230 | 54 |
| 16N77-20-20-SL230-RL320 | SAE 6000 psi 90° elbow - drop length 230 mm | -20 | 1 1/4 | 320 | 256 | 230 | 54 |
| 16377-16-16 | SAE 6000 psi 135° elbow | -16 | 1 | 122 | 68 | 88 | 48 |
| 16377-20-20 | SAE 6000 psi 135° elbow | -20 | 1 1/4 | 132 | 69 | 109 | 54 |
| 16377-24-24 | SAE 6000 psi 135° elbow | -24 | 1 1/2 | 124 | 57 | 129 | 64 |

77 Series

Approved **fitting series** for hose types, depending on size:

| | | | | | | | | | | | | | | | |
|-----------|--------|--------|-------|-----|-------|-------|-----|-------|-------|-----|-------|-------|-------|------|-----|
| 77 | 387 | 387ST | 387TC | 487 | 487ST | 487TC | 787 | 787TC | 787ST | 797 | 797TC | 797ST | 797RH | SX42 | ... |
| | SX42LT | SX42TC | | | | | | | | | | | | | |

Shell

Page De-1



DIN – Metric

Page De-2 – De-5

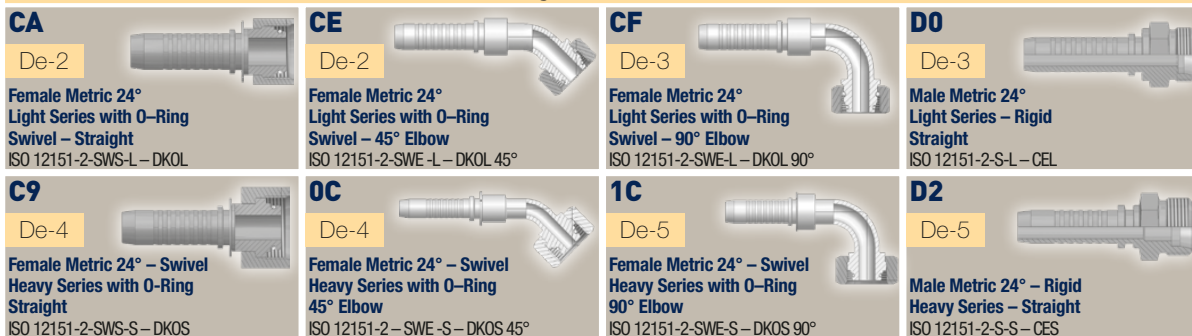

BSP

Page De-6 – De-7







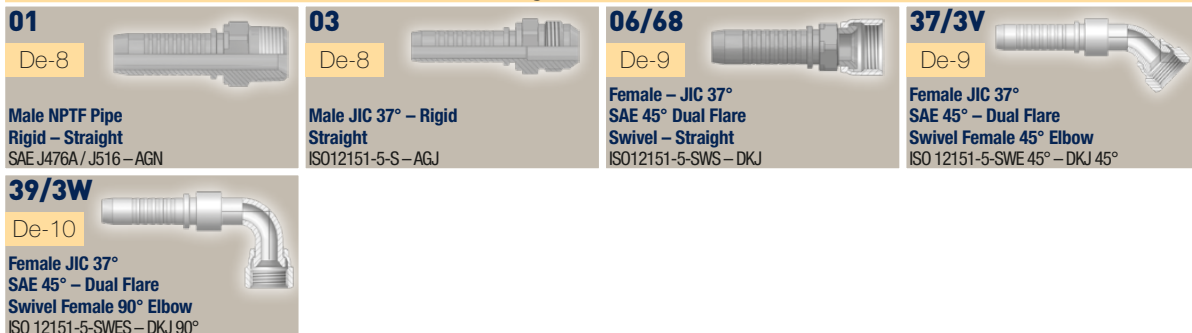

SAE

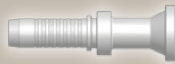

Page De-8 – De-10

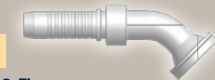

Flange

| Page De-11 – De-13 | | |
|-----------------------------------------------------------------------------------------------------------------------------------------------------------------------------------------------------------------|-----------------------------------------------------------------------------------------------------------------------------------------------------------------------------------------------------------------------------------------|---------------------------------------------------------------------------------------------------------------------------------------------------------------------------------------------------------------------------|
| <p>15</p> <p>De-11</p>  <p>ISO 6162-1-Flange Straight ISO 12151-3-S-L – SFL (21.0 MPa/ 3000 psi)</p> | <p>17</p> <p>De-11</p>  <p>ISO 6162-1-Flange 45° Elbow ISO 12151-3 – E45 – L – SFL 45° (21.0 MPa/ 3000 psi)</p> | <p>19</p> <p>De-12</p>  <p>ISO 6162-1-Flange 90° Elbow ISO 12151-3 – E – L – SFL 90° (21.0 MPa/ 3000 psi)</p> |
| <p>6A</p> <p>De-12</p>  <p>ISO 6162-2-Flange Straight ISO 12151-3-S-S – SFS (42.0 MPa/ 6000 psi)</p> | <p>6F</p> <p>De-13</p>  <p>ISO 6162-2-Flange 45° Elbow – Heavy Series ISO 12151-3 – E45-S – SFS 45° (42.0 MPa/ 6000 psi)</p> | <p>6N</p> <p>De-13</p>  <p>ISO 6162-2-Flange 90° Elbow ISO 12151-3 – E-S – SFS 90° (42.0 MPa/ 6000 psi)</p> |

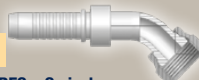
ORFS

| Page De-14 – De-15 | | |
|------------------------------------------------------------------------------------------------------------------------------------------------------------------------------------------------------------------|--------------------------------------------------------------------------------------------------------------------------------------------------------------------------------------------------------------------|-------------------------------------------------------------------------------------------------------------------------------------------------------------------------------------------------------------------------------|
| <p>JC</p> <p>De-14</p>  <p>Female ORFS Swivel – Straight Short ISO 12151-1 – SWSA SAE J516 – ORFS</p> | <p>J7</p> <p>De-14</p>  <p>Female ORFS – Swivel 45° Elbow ISO 12151-1 – SWE 45° SAE J516 – ORFS 45°</p> | <p>J9</p> <p>De-15</p>  <p>Female ORFS – Swivel 90° Elbow – Short Drop ISO 12151-1 – SWES SAE J516 – ORFS 90°</p> |

High Pressure
Shell

ParLock Fittings
VS Series

VS Interlock
Outside Skive



Only for use with
adjustable crimpers.

| Part Number | Hose I.D. | | | | B mm |
|-------------|---------------|------|------|------|---------|
| | DN | Inch | Size | mm | |
| 100VS-4 | 6 | 1/4 | -4 | 6.4 | 38 |
| 100VS-6 | 10 | 3/8 | -6 | 9.5 | 36 |
| 100VS-8 | 12 | 1/2 | -8 | 12.7 | 41 |

VS Series

Approved **fitting series** for hose types, depending on size:

VS H31 H31TC H31ST FA35



De-1

Catalogue 4400/UK

High Pressure
DIN – Metric

ParLock Fittings
VS Series

CA Female Metric 24° Light Series with O-Ring Swivel – Straight

ISO 12151-2-SWS-L – DKOL

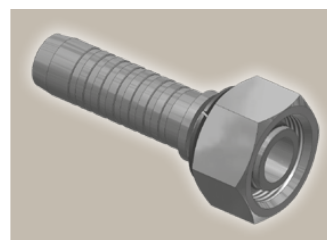
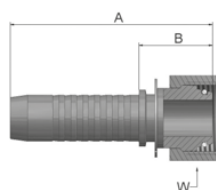

| Part Number | Hose I.D. | | | | Thread metric | Tube O.D. mm | A mm | B mm | W mm |
|-------------|-----------|------|------|------|------------------|--------------------|---------|---------|---------|
| | DN | Inch | Size | mm | | | | | |
| KCAVS-10-6 | 10 | 3/8 | -6 | 9.5 | M16x1.5 | 10 | 65 | 26 | 19 |
| KCAVS-12-6 | 10 | 3/8 | -6 | 9.5 | M18x1.5 | 12 | 62 | 23 | 22 |
| KCAVS-15-8 | 12 | 1/2 | -8 | 12.7 | M22x1.5 | 15 | 70 | 27 | 27 |

Fittings with standard O-ring seals can be used for temperatures from -40 °C up to +105 °C.
O-rings see section Eb. Special O-rings are available on request.

CE Female Metric 24° Light Series with O-Ring Swivel – 45° Elbow

ISO 12151-2-SWE -L – DKOL 45°

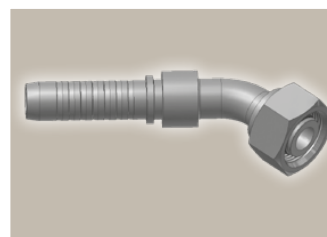
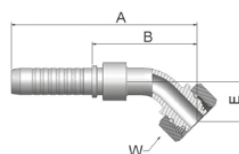

| Part Number | Hose I.D. | | | | Thread metric | Tube O.D. mm | A mm | B mm | E mm | W mm |
|-------------|-----------|------|------|------|------------------|--------------------|---------|---------|---------|---------|
| | DN | Inch | Size | mm | | | | | | |
| KCEVS-12-6 | 10 | 3/8 | -6 | 9.5 | M18x1.5 | 12 | 94 | 55 | 20 | 22 |
| KCEVS-15-8 | 12 | 1/2 | -8 | 12.7 | M22x1.5 | 15 | 104 | 62 | 24 | 27 |

Fittings with standard O-ring seals can be used for temperatures from -40 °C up to +105 °C.
O-rings see section Eb. Special O-rings are available on request.

Approved **fitting series** for hose types, depending on size:

VS H31 H31TC H31ST FA35



De-2

Catalogue 4400/UK

CF **Female Metric 24°
Light Series with O-Ring
Swivel – 90° Elbow**

ISO 12151-2-SWE-L – DKOL 90°

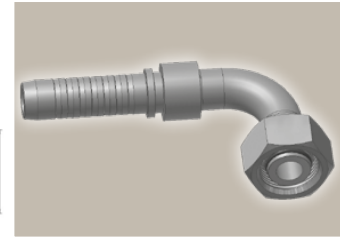
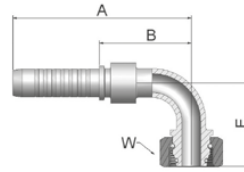

| Part Number | Hose I.D. | | | | Thread metric | Tube O.D. mm | A mm | B mm | E mm | W mm |
|-------------|-----------|------|------|------|------------------|--------------------|---------|---------|---------|---------|
| | DN | Inch | Size | mm | | | | | | |
| KCFVS-12-6 | 10 | 3/8 | -6 | 9.5 | M18x1.5 | 12 | 83 | 45 | 36 | 22 |
| KCFVS-15-8 | 12 | 1/2 | -8 | 12.7 | M22x1.5 | 15 | 92 | 50 | 45 | 27 |

Fittings with standard O-ring seals can be used for temperatures from -40 °C up to +105 °C.
O-rings see section Eb. Special O-rings are available on request.

D0 **Male Metric 24°
Light Series – Rigid
Straight**

ISO 12151-2-S-L – CEL

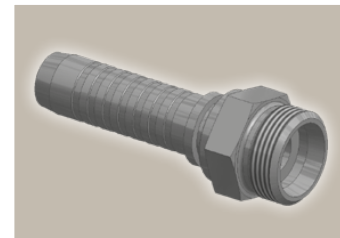
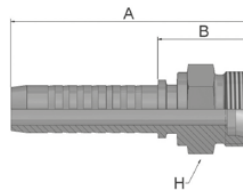

| Part Number | Hose I.D. | | | | Thread metric | Tube O.D. mm | A mm | B mm | H mm |
|-------------|-----------|------|------|------|------------------|--------------------|---------|---------|---------|
| | DN | Inch | Size | mm | | | | | |
| KDOVS-12-6 | 10 | 3/8 | -6 | 9.5 | M18x1.5 | 12 | 64 | 25 | 19 |
| KDOVS-15-8 | 12 | 1/2 | -8 | 12.7 | M22x1.5 | 15 | 71 | 28 | 22 |

VS Series

Approved **fitting series** for hose types, depending on size:

VS H31 | H31TC | H31ST | FA35



C9 Female Metric 24° – Swivel Heavy Series with O-Ring Straight

ISO 12151-2-SWS-S – DKOS

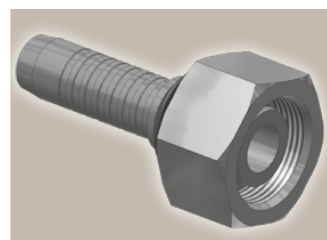
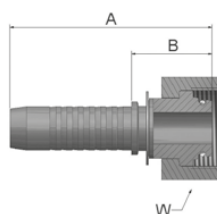

| Part Number | Hose I.D. | | | | Thread metric | Tube O.D. mm | A mm | B mm | W mm |
|-------------|-----------|------|------|------|------------------|--------------------|---------|---------|---------|
| | DN | Inch | Size | mm | | | | | |
| KC9VS-8-4 | 6 | 1/4 | -4 | 6.4 | M16x1.5 | 8 | 61 | 23 | 19 |
| KC9VS-10-4 | 6 | 1/4 | -4 | 6.4 | M18x1.5 | 10 | 62 | 24 | 22 |
| KC9VS-8-6 | 10 | 3/8 | -6 | 9.5 | M16x1.5 | 8 | 64 | 25 | 19 |
| KC9VS-12-6 | 10 | 3/8 | -6 | 9.5 | M20x1.5 | 12 | 63 | 25 | 24 |
| KC9VS-14-6 | 10 | 3/8 | -6 | 9.5 | M22x1.5 | 14 | 63 | 24 | 27 |
| KC9VS-16-8 | 12 | 1/2 | -8 | 12.7 | M24x1.5 | 16 | 71 | 29 | 30 |
| KC9VS-20-8 | 12 | 1/2 | -8 | 12.7 | M30x2 | 20 | 71 | 29 | 36 |

Fittings with standard O-ring seals can be used for temperatures from -40 °C up to +105 °C.
O-rings see section Eb. Special O-rings are available on request.

OC Female Metric 24° – Swivel Heavy Series with O-Ring 45° Elbow

ISO 12151-2 – SWE -S – DKOS 45°

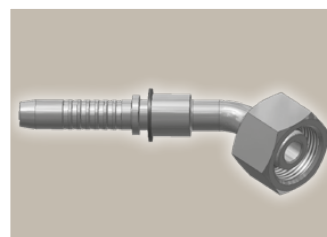
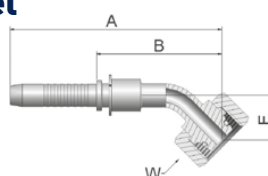

| Part Number | Hose I.D. | | | | Thread metric | Tube O.D. mm | A mm | B mm | E mm | W mm |
|-------------|-----------|------|------|------|------------------|--------------------|---------|---------|---------|---------|
| | DN | Inch | Size | mm | | | | | | |
| KOCVS-8-4 | 6 | 1/4 | -4 | 6.4 | M16x1.5 | 8 | 88 | 50 | 16 | 19 |
| KOCVS-10-4 | 6 | 1/4 | -4 | 6.4 | M18x1.5 | 10 | 88 | 50 | 16 | 22 |
| KOCVS-12-6 | 10 | 3/8 | -6 | 9.5 | M20x1.5 | 12 | 94 | 56 | 20 | 24 |
| KOCVS-14-6 | 10 | 3/8 | -6 | 9.5 | M22x1.5 | 14 | 94 | 56 | 20 | 27 |
| KOCVS-16-8 | 12 | 1/2 | -8 | 12.7 | M24x1.5 | 16 | 105 | 62 | 24 | 30 |

Fittings with standard O-ring seals can be used for temperatures from -40 °C up to +105 °C.
O-rings see section Eb. Special O-rings are available on request.

Approved **fitting series** for hose types, depending on size:

VS H31 H31TC H31ST FA35

1C Female Metric 24° – Swivel Heavy Series with O-Ring 90° Elbow

ISO 12151-2-SWE-S – DKOS 90°

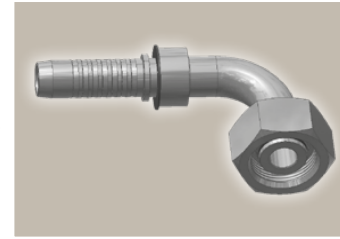
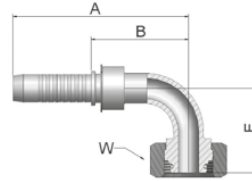

| Part Number | Hose I.D. | | | | Thread metric | Tube O.D. mm | A mm | B mm | E mm | W mm |
|-------------|-----------|------|------|------|---------------|--------------|------|------|------|------|
| | DN | Inch | Size | mm | | | | | | |
| K1CVS-8-4 | 6 | 1/4 | -4 | 6.4 | M16x1.5 | 8 | 79 | 41 | 29 | 19 |
| K1CVS-10-4 | 6 | 1/4 | -4 | 6.4 | M18x1.5 | 10 | 79 | 41 | 29 | 22 |
| K1CVS-12-6 | 10 | 3/8 | -6 | 9.5 | M20x1.5 | 12 | 83 | 45 | 37 | 24 |
| K1CVS-14-6 | 10 | 3/8 | -6 | 9.5 | M22x1.5 | 12 | 83 | 45 | 37 | 27 |
| K1CVS-16-8 | 12 | 1/2 | -8 | 12.7 | M24x1.5 | 16 | 93 | 51 | 45 | 30 |

Fittings with standard O-ring seals can be used for temperatures from -40 °C up to +105 °C. O-rings see section Eb. Special O-rings are available on request.

D2 Male Metric 24° – Rigid Heavy Series – Straight

ISO 12151-2-S-S – CES

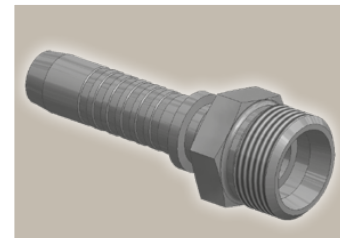
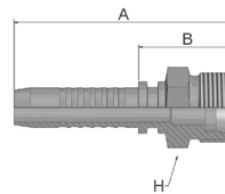

| Part Number | Hose I.D. | | | | Thread metric | Tube O.D. mm | A mm | B mm | H mm |
|-------------|-----------|------|------|------|---------------|--------------|------|------|------|
| | DN | Inch | Size | mm | | | | | |
| KD2VS-12-6 | 10 | 3/8 | -6 | 9.5 | M20x1.5 | 12 | 66 | 27 | 22 |
| KD2VS-14-6 | 10 | 3/8 | -6 | 9.5 | M22x1.5 | 14 | 68 | 30 | 22 |
| KD2VS-16-8 | 12 | 1/2 | -8 | 12.7 | M24x1.5 | 16 | 74 | 31 | 24 |

VS Series

Approved **fitting series** for hose types, depending on size:

VS H31 | H31TC | H31ST | FA35



92 Female BSP Parallel Pipe Swivel – Straight (60° Cone)

BS5200-A – DKR

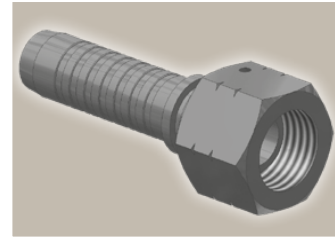
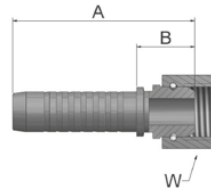

| Part Number | Hose I.D. | | | | Thread BSP | A mm | B mm | W mm |
|-------------|-----------|------|------|------|---------------|---------|---------|---------|
| | DN | Inch | Size | mm | | | | |
| K92VS-6-6 | 10 | 3/8 | -6 | 9.5 | 3/8x19 | 60 | 22 | 22 |
| K92VS-8-6 | 10 | 3/8 | -6 | 9.5 | 1/2x14 | 62 | 23 | 27 |
| K92VS-8-8 | 12 | 1/2 | -8 | 12.7 | 1/2x14 | 67 | 24 | 27 |
| K92VS-10-8 | 12 | 1/2 | -8 | 12.7 | 5/8x14 | 65 | 23 | 30 |

B1 Female BSP Parallel Pipe Swivel 45° Elbow (60° Cone)

BS 5200-D – DKR 45°

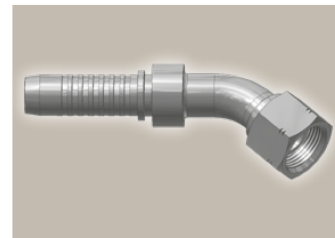
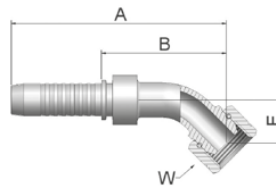

| Part Number | Hose I.D. | | | | Thread BSP | A mm | B mm | E mm | W mm |
|-------------|-----------|------|------|------|---------------|---------|---------|---------|---------|
| | DN | Inch | Size | mm | | | | | |
| KB1VS-6-6 | 10 | 3/8 | -6 | 9.5 | 3/8x19 | 90 | 52 | 17 | 22 |
| KB1VS-8-8 | 12 | 1/2 | -8 | 12.7 | 1/2x14 | 100 | 58 | 20 | 27 |
| KB1VS-10-8 | 12 | 1/2 | -8 | 12.7 | 5/8x14 | 99 | 57 | 19 | 30 |

Approved **fitting series** for hose types, depending on size:

VS H31 H31TC H31ST FA35

B2 Female BSP Parallel Pipe Swivel 90° Elbow (60° Cone)

BS 5200-B – DKR 90°

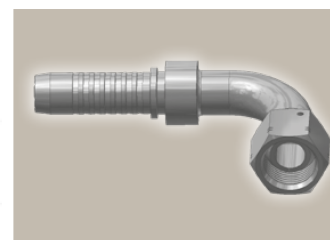
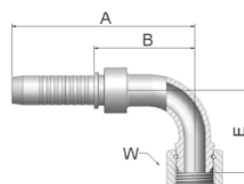

| Part Number | Hose I.D. | | | | Thread BSP | A mm | B mm | E mm | W mm |
|-------------|-----------|------|------|------|---------------|---------|---------|---------|---------|
| | DN | Inch | Size | mm | | | | | |
| KB2VS-6-6 | 10 | 3/8 | -6 | 9.5 | 3/8x19 | 82 | 44 | 33 | 22 |
| KB2VS-8-6 | 10 | 3/8 | -6 | 9.5 | 1/2x14 | 83 | 45 | 36 | 27 |
| KB2VS-8-8 | 12 | 1/2 | -8 | 12.7 | 1/2x14 | 92 | 50 | 40 | 27 |
| KB2VS-10-8 | 12 | 1/2 | -8 | 12.7 | 5/8x14 | 92 | 50 | 38 | 30 |

D9 Male BSP Parallel Pipe Rigid – Straight (60° Cone)

BS5200 – AGR

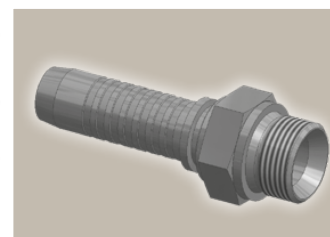
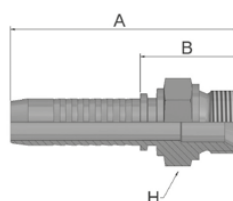

| Part Number | Hose I.D. | | | | Thread BSP | A mm | B mm | H mm |
|-------------|-----------|------|------|------|---------------|---------|---------|---------|
| | DN | Inch | Size | mm | | | | |
| KD9VS-4-4 | 6 | 1/4 | -4 | 6.4 | 1/4x19 | 67 | 28 | 19 |
| KD9VS-6-6 | 10 | 3/8 | -6 | 9.5 | 3/8x19 | 71 | 33 | 22 |
| KD9VS-8-8 | 12 | 1/2 | -8 | 12.7 | 1/2x14 | 78 | 36 | 27 |

VS Series

Approved **fitting series** for hose types, depending on size:

VS | H31 | H31TC | H31ST | FA35

01 Male NPTF Pipe Rigid – Straight

SAE J476A / J516 – AGN

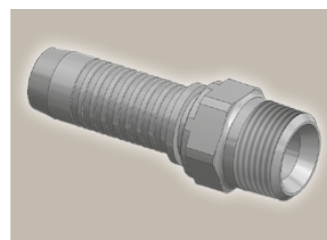
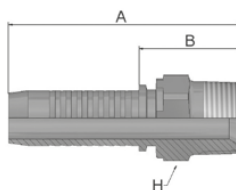

| Part Number | Hose I.D. | | | | Thread NPTF | A mm | B mm | H mm |
|-------------|-----------|------|------|------|----------------|---------|---------|---------|
| | DN | Inch | Size | mm | | | | |
| K01VS-6-6 | 10 | 3/8 | -6 | 9.5 | 3/8-18 | 71 | 33 | 19 |
| K01VS-8-8 | 12 | 1/2 | -8 | 12.7 | 1/2-14 | 83 | 40 | 22 |

03 Male JIC 37° – Rigid Straight

ISO12151-5-S – AGJ

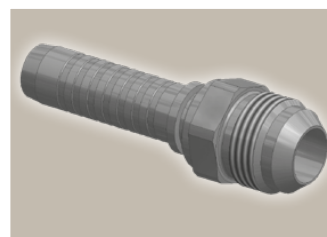
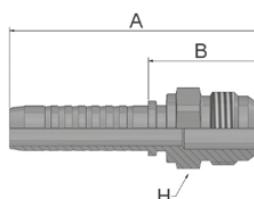

| Part Number | Hose I.D. | | | | Thread UNF | A mm | B mm | H mm |
|-------------|-----------|------|------|------|---------------|---------|---------|---------|
| | DN | Inch | Size | mm | | | | |
| K03VS-6-6 | 10 | 3/8 | -6 | 9.5 | 9/16x18 | 71 | 32 | 19 |
| K03VS-8-6 | 10 | 3/8 | -6 | 9.5 | 3/4x16 | 69 | 31 | 22 |
| K03VS-8-8 | 12 | 1/2 | -8 | 12.7 | 3/4x16 | 79 | 36 | 22 |
| K03VS-10-8 | 12 | 1/2 | -8 | 12.7 | 7/8x14 | 77 | 35 | 24 |

Approved **fitting series** for hose types, depending on size:

VS H31 | H31TC | H31ST | FA35

06/68 Female – JIC 37°
SAE 45° Dual Flare
Swivel – Straight
ISO12151-5-SWS – DKJ

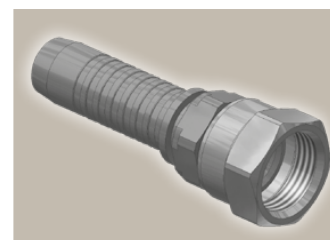
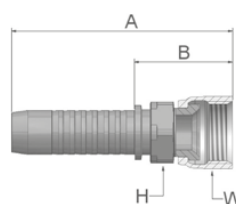

| Part Number | Hose I.D. | | | | Thread UNF | A mm | B mm | H mm | W mm |
|-------------|-----------|------|------|------|---------------|---------|---------|---------|---------|
| | DN | Inch | Size | mm | | | | | |
| K68VS-4-4 | 6 | 1/4 | -4 | 6.4 | 7/16 20 | 66 | 28 | 14 | 17 |
| K06VS-6-6 | 10 | 3/8 | -6 | 9.5 | 9/16x18 | 69 | 31 | 17 | 19 |
| K68VS-8-6 | 10 | 3/8 | -6 | 9.5 | 3/4x16 | 74 | 35 | 17 | 22 |
| K68VS-8-8 | 12 | 1/2 | -8 | 12.7 | 3/4x16 | 77 | 35 | 22 | 22 |
| K68VS-10-8 | 12 | 1/2 | -8 | 12.7 | 7/8x14 | 83 | 41 | 22 | 27 |
| K06VS-12-8 | 12 | 1/2 | -8 | 12.7 | 1 1/16x12 | 83 | 41 | 27 | 32 |

37/3V Female JIC 37°
SAE 45° – Dual Flare
Swivel Female 45° Elbow
ISO 12151-5-SWE 45° – DKJ 45°

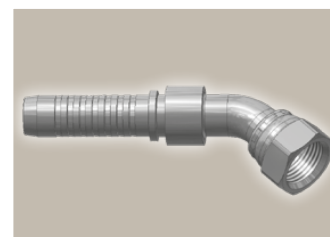
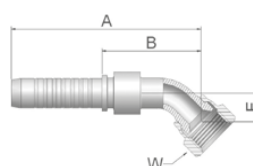

| Part Number | Hose I.D. | | | | Thread UNF | A mm | B mm | E mm | W mm |
|-------------|-----------|------|------|------|---------------|---------|---------|---------|---------|
| | DN | Inch | Size | mm | | | | | |
| K37VS-6-6 | 10 | 3/8 | -6 | 9.5 | 9/16x18 | 83 | 45 | 11 | 19 |
| K3VVS-8-6 | 10 | 3/8 | -6 | 9.5 | 3/4x16 | 87 | 49 | 15 | 22 |
| K3VVS-8-8 | 12 | 1/2 | -8 | 12.7 | 3/4x16 | 93 | 51 | 15 | 22 |
| K3VVS-10-8 | 12 | 1/2 | -8 | 12.7 | 7/8x14 | 94 | 52 | 16 | 27 |
| K37VS-12-8 | 12 | 1/2 | -8 | 12.7 | 1 1/16x12 | 99 | 57 | 21 | 32 |

VS Series

Approved **fitting series** for hose types, depending on size:

VS | H31 | H31TC | H31ST | FA35



High Pressure
SAE

ParLock Fittings
VS Series

39/3W Female JIC 37°
SAE 45° - Dual Flare
Swivel Female 90° Elbow
ISO 12151-5-SWES - DKJ 90°

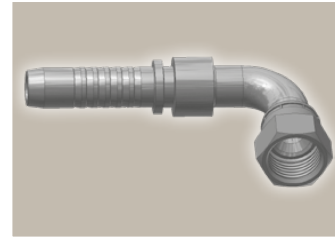
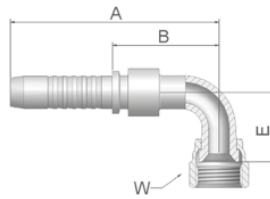

| Part Number | Hose I.D. | | | | Thread UNF | A mm | B mm | E mm | W mm |
|-------------|-----------|------|------|------|---------------|---------|---------|---------|---------|
| | DN | Inch | Size | mm | | | | | |
| K39VS-6-6 | 10 | 3/8 | -6 | 9.5 | 9/16x18 | 80 | 42 | 23 | 19 |
| K3WVS-8-6 | 10 | 3/8 | -6 | 9.5 | 3/4x16 | 80 | 42 | 29 | 22 |
| K3WVS-8-8 | 12 | 1/2 | -8 | 12.7 | 3/4x16 | 87 | 45 | 29 | 22 |
| K3WVS-10-8 | 12 | 1/2 | -8 | 12.7 | 7/8x14 | 87 | 45 | 32 | 27 |

Approved **fitting series** for hose types, depending on size:

VS H31 | H31TC | H31ST | FA35



De-10

Catalogue 4400/UK

15 ISO 6162-1-Flange Straight

ISO 12151-3-S-L – SFL
(21.0 MPa/ 3000 psi)

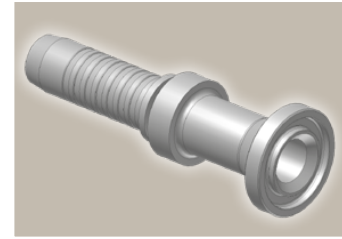
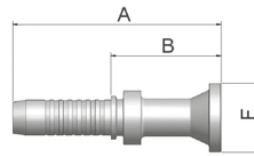

| Part Number | Hose I.D. | | | | Flange Inch | A mm | B mm | F mm |
|-------------|-----------|------|------|------|----------------|---------|---------|---------|
| | DN | Inch | Size | mm | | | | |
| K15VS-8-8 | 12 | 1/2 | -8 | 12.7 | 1/2 | 102 | 59 | 30 |
| K15VS-12-8 | 12 | 1/2 | -8 | 12.7 | 3/4 | 77 | 34 | 38 |

SAE flange halves see in section Eb.

17 ISO 6162-1 Flange 45° Elbow

ISO 12151-3 – E45 – L – SFL 45°
(21.0 MPa/ 3000 psi)

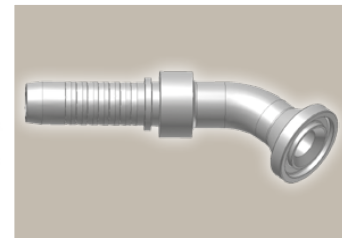
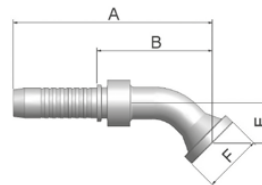

| Part Number | Hose I.D. | | | | Flange Inch | A mm | B mm | E mm | F mm |
|-------------|-----------|------|------|------|----------------|---------|---------|---------|---------|
| | DN | Inch | Size | mm | | | | | |
| K17VS-8-8 | 12 | 1/2 | -8 | 12.7 | 1/2 | 100 | 57 | 20 | 30 |
| K17VS-12-8 | 12 | 1/2 | -8 | 12.7 | 3/4 | 101 | 58 | 21 | 38 |

SAE flange halves see in section Eb.

VS Series

Approved **fitting series** for hose types, depending on size:

VS H31 | H31TC | H31ST | FA35

19

ISO 6162-1-Flange 90° Elbow

ISO 12151-3 – E– L – SFL 90°
(21.0 MPa/ 3000 psi)

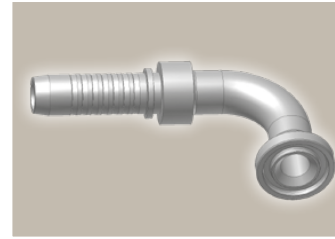
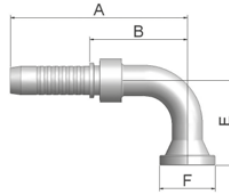

| Part Number | Hose I.D. | | | | Flange Inch | A mm | B mm | E mm | F mm |
|-------------|-----------|------|------|------|----------------|---------|---------|---------|---------|
| | DN | Inch | Size | mm | | | | | |
| K19VS-8-8 | 12 | 1/2 | -8 | 12.7 | 1/2 | 92 | 50 | 41 | 30 |
| K19VS-12-8 | 12 | 1/2 | -8 | 12.7 | 3/4 | 92 | 50 | 42 | 38 |

SAE flange halves see in section Eb.

6A

ISO 6162-2-Flange Straight

ISO 12151-3-S-S – SFS
(42.0 MPa/ 6000 psi)

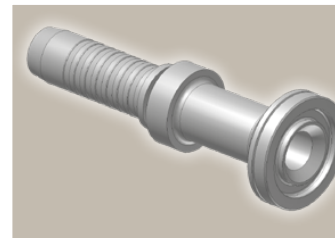
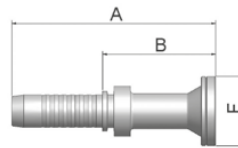

| Part Number | Hose I.D. | | | | Flange Inch | A mm | B mm | F mm |
|-------------|-----------|------|------|------|----------------|---------|---------|---------|
| | DN | Inch | Size | mm | | | | |
| K6AVS-8-8 | 12 | 1/2 | -8 | 12.7 | 1/2 | 105 | 63 | 32 |
| K6AVS-12-8 | 12 | 1/2 | -8 | 12.7 | 3/4 | 79 | 36 | 41 |

SAE flange halves see in section Eb.

Approved **fitting series** for hose types, depending on size:

VS H31 | H31TC | H31ST | FA35



6F ISO 6162-2-Flange 45° Elbow – Heavy Series

ISO 12151-3 – E45-S – SFS 45°
(42.0 MPa/ 6000 psi)

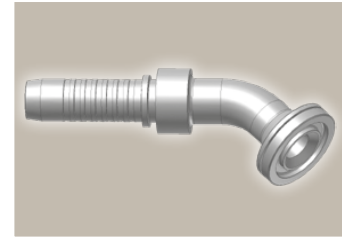
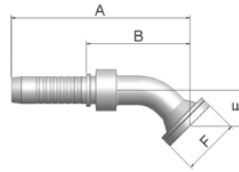

| Part Number | Hose I.D. | | | | Flange Inch | A mm | B mm | E mm | F mm |
|-------------|-----------|------|------|------|----------------|---------|---------|---------|---------|
| | DN | Inch | Size | mm | | | | | |
| K6FVS-8-8 | 12 | 1/2 | -8 | 12.7 | 1/2 | 94 | 52 | 19 | 32 |
| K6FVS-12-8 | 12 | 1/2 | -8 | 12.7 | 3/4 | 106 | 64 | 26 | 41 |

SAE flange halves see in section Eb.

6N ISO 6162-2-Flange 90° Elbow

ISO 12151-3 – E-S – SFS 90°
(42.0 MPa/ 6000 psi)

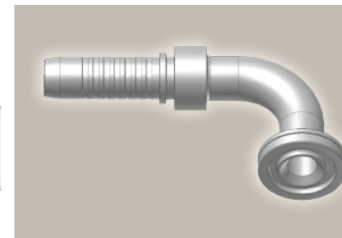
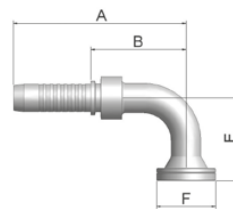

| Part Number | Hose I.D. | | | | Flange Inch | A mm | B mm | E mm | F mm |
|-------------|-----------|------|------|------|----------------|---------|---------|---------|---------|
| | DN | Inch | Size | mm | | | | | |
| K6NVS-8-8 | 12 | 1/2 | -8 | 12.7 | 1/2 | 87 | 45 | 41 | 32 |
| K6NVS-12-8 | 12 | 1/2 | -8 | 12.7 | 3/4 | 92 | 50 | 45 | 41 |

SAE flange halves see in section Eb.

VS Series

Approved **fitting series** for hose types, depending on size:

VS H31 | H31TC | H31ST | FA35

JC Female ORFS Swivel – Straight Short

ISO 12151-1 – SWSA
SAE J516 – ORFS

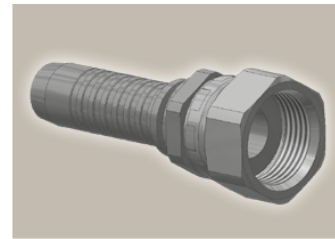
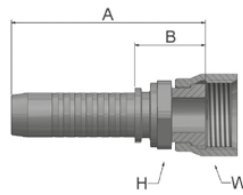

| Part Number | Hose I.D. | | | | Thread UNF | A mm | B mm | H mm | W mm |
|-------------|-----------|------|------|------|---------------|---------|---------|---------|---------|
| | DN | Inch | Size | mm | | | | | |
| KJCVS-6-6 | 10 | 3/8 | -6 | 9.5 | 11/16x16 | 60 | 22 | 17 | 22 |
| KJCVS-8-6 | 10 | 3/8 | -6 | 9.5 | 13/16x16 | 62 | 23 | 19 | 24 |
| KJCVS-8-8 | 12 | 1/2 | -8 | 12.7 | 13/16x16 | 67 | 24 | 22 | 24 |
| KJCVS-10-8 | 12 | 1/2 | -8 | 12.7 | 1x14 | 69 | 26 | 24 | 30 |

J7 Female ORFS – Swivel 45° Elbow

ISO 12151-1 – SWE 45°
SAE J516 – ORFS 45°

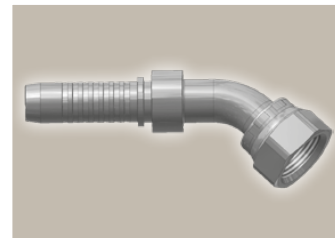
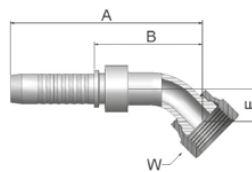

| Part Number | Hose I.D. | | | | Thread UNF | A mm | B mm | E mm | W mm |
|-------------|-----------|------|------|------|---------------|---------|---------|---------|---------|
| | DN | Inch | Size | mm | | | | | |
| KJ7VS-6-6 | 10 | 3/8 | -6 | 9.5 | 11/16x16 | 83 | 45 | 11 | 22 |
| KJ7VS-8-6 | 10 | 3/8 | -6 | 9.5 | 13/16x16 | 89 | 51 | 15 | 24 |
| KJ7VS-8-8 | 12 | 1/2 | -8 | 12.7 | 13/16x16 | 93 | 51 | 15 | 24 |
| KJ7VS-10-8 | 12 | 1/2 | -8 | 12.7 | 1x14 | 96 | 53 | 16 | 30 |



Approved **fitting series** for hose types, depending on size:

VS H31 H31TC H31ST FA35

J9 **Female ORFS – Swivel
90° Elbow – Short Drop**

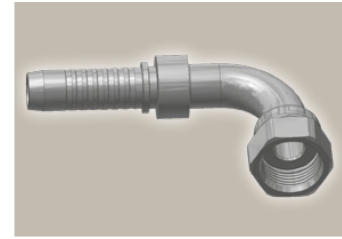
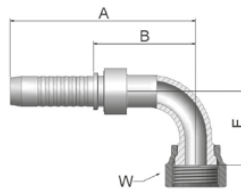
ISO 12151-1 – SWES
SAE J516 – ORFS 90°





| Part Number |  Hose I.D. | | | |  Thread UNF | A mm | B mm | E mm |  W mm |
|-------------|------------------------------------------------------------------------------------------------|------|------|------|----------------------------------------------------------------------------------------------------|---------|---------|---------|------------------------------------------------------------------------------------------------|
| | DN | Inch | Size | mm | | | | | |
| KJ9VS-6-6 | 10 | 3/8 | -6 | 9.5 | 11/16x16 | 80 | 42 | 23 | 22 |
| KJ9VS-8-6 | 10 | 3/8 | -6 | 9.5 | 13/16x16 | 83 | 45 | 29 | 24 |
| KJ9VS-8-8 | 12 | 1/2 | -8 | 12.7 | 13/16x16 | 87 | 45 | 29 | 24 |
| KJ9VS-10-8 | 12 | 1/2 | -8 | 12.7 | 1x14 | 88 | 46 | 30 | 30 |

Approved **fitting series** for hose types, depending on size:

VS H31 H31TC H31ST FA35







Shell

Page Df-1

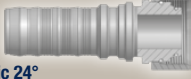
| | |
|---------------------------------------------------------------------------------------------------------------------------------------------------------------------------|---------------------------------------------------------------------------------------------------------------------------------------------------------------------------|
| <p>V4</p> <p>Df-1</p>  <p>Interlock In-/Outside Skive 4 Wire Hoses</p> | <p>V6</p> <p>Df-1</p>  <p>Interlock In-/Outside Skive 6 Wire Hoses</p> |
|---------------------------------------------------------------------------------------------------------------------------------------------------------------------------|---------------------------------------------------------------------------------------------------------------------------------------------------------------------------|





DIN – Metric

Page Df-2 – Df-5

| | | | |
|-----------------------------------------------------------------------------------------------------------------------------------------------------------------------------------------------------------------------------|-----------------------------------------------------------------------------------------------------------------------------------------------------------------------------------------------------------------------------|------------------------------------------------------------------------------------------------------------------------------------------------------------------------------------------------------------------------------|--------------------------------------------------------------------------------------------------------------------------------------------------------------------------------------------------------------------------|
| <p>CA</p> <p>Df-2</p>  <p>Female Metric 24° Light Series with O-Ring Swivel – Straight ISO 12151-2-SWS-L – DKOL</p> | <p>CE</p> <p>Df-2</p>  <p>Female Metric 24° Light Series with O-Ring Swivel – 45° Elbow ISO 12151-2-SWE-L – DKOL 45°</p> | <p>CF</p> <p>Df-3</p>  <p>Female Metric 24° Light Series with O-Ring Swivel – 90° Elbow ISO 12151-2-SWE-L – DKOL 90°</p> | <p>C9</p> <p>Df-3</p>  <p>Female Metric 24° – Swivel Heavy Series with O-Ring Straight ISO 12151-2-SWS-S – DKOS</p> |
| <p>0C</p> <p>Df-4</p>  <p>Female Metric 24° – Swivel Heavy Series with O-Ring 45° Elbow ISO 12151-2-SWE-S – DKOS 45°</p> | <p>1C</p> <p>Df-4</p>  <p>Female Metric 24° – Swivel Heavy Series with O-Ring 90° Elbow ISO 12151-2-SWE-S – DKOS 90°</p> | <p>D2</p> <p>Df-5</p>  <p>Male Metric 24° – Rigid Heavy Series – Straight ISO 12151-2-S-S – CES</p> | |

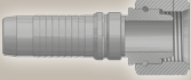

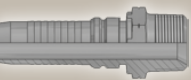

BSP

Page Df-6 – Df-8

| | | | |
|---------------------------------------------------------------------------------------------------------------------------------------------------------------------------------------------------------|-------------------------------------------------------------------------------------------------------------------------------------------------------------------------------------------------------------|--------------------------------------------------------------------------------------------------------------------------------------------------------------------------------------------------------------|------------------------------------------------------------------------------------------------------------------------------------------------------------------------------------------------------|
| <p>92</p> <p>Df-6</p>  <p>Female BSP Parallel Pipe Swivel – Straight (60° Cone) BS5200-A – DKR</p> | <p>B1</p> <p>Df-6</p>  <p>Female BSP Parallel Pipe Swivel 45° Elbow (60° Cone) BS 5200-D – DKR 45°</p> | <p>B2</p> <p>Df-7</p>  <p>Female BSP Parallel Pipe Swivel 90° Elbow (60° Cone) BS 5200-B – DKR 90°</p> | <p>D9</p> <p>Df-7</p>  <p>Male BSP Parallel Pipe Rigid – Straight (60° Cone) BS5200 – AGR</p> |
| <p>91</p> <p>Df-8</p>  <p>Male BSP Taper Pipe – Rigid Straight BS5200 – AGR-K</p> | | | |

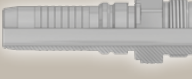
SAE

Page Df-9 – Df-11

| | | | |
|--------------------------------------------------------------------------------------------------------------------------------------------------------------------------------------------------|-------------------------------------------------------------------------------------------------------------------------------------------------------------------------------------|--------------------------------------------------------------------------------------------------------------------------------------------------------------------------------------------|-------------------------------------------------------------------------------------------------------------------------------------------------------------------------------------------------------|
| <p>01</p> <p>Df-9</p>  <p>Male NPTF Pipe Rigid – Straight SAE J476A / J516 – AGN</p> | <p>03</p> <p>Df-9</p>  <p>Male JIC 37° – Rigid Straight ISO12151-5-S – AGJ</p> | <p>06</p> <p>Df-10</p>  <p>Female JIC 37° – Swivel Straight ISO12151-5-SWS – DKJ</p> | <p>37</p> <p>Df-10</p>  <p>Female JIC 37° – Swivel 45° Elbow ISO 12151-5-SWE 45° – DKJ 45°</p> |
| <p>39</p> <p>Df-11</p>  <p>Female JIC 37° – Swivel 90° Elbow ISO 12151-5-SWES – DKJ 90°</p> | | | |

Flange

Page Df-12 – Df-22

| | | | |
|-------------------------------------------------------------------------------------------------------------------------------------------------------------------------------------------------------------------------------------|----------------------------------------------------------------------------------------------------------------------------------------------------------------------------------------------------------------------------|----------------------------------------------------------------------------------------------------------------------------------------------------------------------------------------------------------------------|---------------------------------------------------------------------------------------------------------------------------------------------------------------------------------------------------------------|
| <p>15/4A</p> <p>Df-12</p>  <p>ISO 6162-1-Flange Straight ISO 12151-3-S-L – SFL (35.0 MPa/ 5000 psi)</p> | <p>17/4F</p> <p>Df-13</p>  <p>ISO 6162-1-Flange 45° Elbow ISO 12151-3 – E45S – L – SFL 45° (35.0 MPa/ 5000 psi)</p> | <p>19/4N</p> <p>Df-14</p>  <p>ISO 6162-1-Flange 90° Elbow ISO 12151-3-E-L – SFL 90° (35.0 MPa/ 5000 psi)</p> | <p>6A</p> <p>Df-15</p>  <p>ISO 6162-2-Flange Straight ISO 12151-3-S-S – SFS (42.0 MPa/ 6000 psi)</p> |
| <p>6F</p> <p>Df-16</p>  <p>ISO 6162-2-Flange 45° Elbow – Heavy Series ISO 12151-3 – E45-S – SFS 45° (42.0 MPa/ 6000 psi)</p> | <p>6N</p> <p>Df-17</p>  <p>ISO 6162-2-Flange 90° Elbow ISO 12151-3 – E-S – SFS 90° (42.0 MPa/ 6000 psi)</p> | <p>8A</p> <p>Df-18</p>  <p>Flange – Straight 8000 psi</p> | <p>8F</p> <p>Df-18</p>  <p>Flange – 45° Elbow 8000 psi</p> |
| <p>8N</p> <p>Df-19</p>  <p>Flange – 90° Elbow 8000 psi</p> | <p>X5</p> <p>Df-19</p>  <p>Flange – Straight Full flange system for ISO 6162-1 or ISO 6162-2</p> | <p>X7</p> <p>Df-20</p>  <p>Flange – 45° Elbow Full flange system for ISO 6162-1 or ISO 6162-2</p> | <p>X9</p> <p>Df-20</p>  <p>Flange – 90° Elbow Full flange system for ISO 6162-1 or ISO 6162-2</p> |
| <p>XA</p> <p>Df-21</p>  <p>Caterpillar® Flange Straight</p> | <p>XF</p> <p>Df-21</p>  <p>Caterpillar® Flange 45° Elbow</p> | <p>XG</p> <p>Df-22</p>  <p>Caterpillar® Flange 60° Elbow</p> | <p>XN</p> <p>Df-22</p>  <p>Caterpillar® Flange 90° Elbow</p> |

ORFS

Page Df-23 – Df-25

| | | | |
|--------------------------------------------------------------------------------------------------------------------------------------------------------------------------------------------|----------------------------------------------------------------------------------------------------------------------------------------------------------------------------------------------------|-------------------------------------------------------------------------------------------------------------------------------------------------------------------------------------------------------------------|------------------------------------------------------------------------------------------------------------------------------------------------------------------------------------------------------------------------------|
| <p>JC</p> <p>Df-23</p>  <p>Female ORFS Swivel – Straight Short ISO 12151-1 – SWSA</p> | <p>JS</p> <p>Df-23</p>  <p>ORFS Swivel Female (Long) ISO 12151-1-SWSB SAE J516 – ORFS</p> | <p>J7</p> <p>Df-24</p>  <p>Female ORFS – Swivel 45° Elbow ISO 12151-1 – SWE 45° SAE J516 – ORFS 45°</p> | <p>J9</p> <p>Df-24</p>  <p>Female ORFS – Swivel 90° Elbow – Short Drop ISO 12151-1 – SWES SAE J516 – ORFS 90°</p> |
| <p>JM</p> <p>Df-25</p>  <p>ORFS Male ISO 12151-1-S – SAE J516</p> | | | |

V4/V6 Series

V4 Interlock In-/Outside Skive

4 Wire Hoses

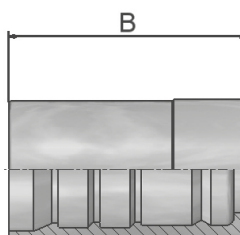

Only for use with adjustable crimpers.
Minimum of 320 tons crimping force recommended.

| Part Number | Hose I.D. | | | | B mm |
|-------------|-----------|-------|------|------|---------|
| | DN | Inch | Size | mm | |
| 100V4-10 | 16 | 5/8 | -10 | 15.9 | 49 |
| 100V4-12 | 19 | 3/4 | -12 | 19.1 | 60 |
| 100V4-16 | 25 | 1 | -16 | 25.4 | 75 |
| 100V4-20 * | 31 | 1 1/4 | -20 | 31.8 | 88 |
| 100V6-20 * | 31 | 1 1/4 | -20 | 31.8 | 90 |
| 100V4-24 * | 38 | 1 1/2 | -24 | 38.1 | 94 |

* not suitable for R42, R42TC and R42ST

V6 Interlock In-/Outside Skive

6 Wire Hoses

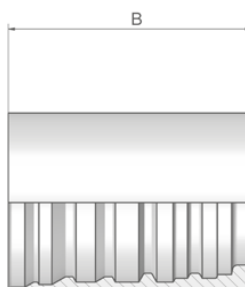

Only for use with adjustable crimpers.
Minimum of 340 tons crimping force required.

| Part Number | Hose I.D. | | | | B mm |
|-------------|-----------|-------|------|------|---------|
| | DN | Inch | Size | mm | |
| 100V6-24 | 38 | 1 1/2 | -24 | 38.1 | 96 |
| 100V6-32 | 51 | 2 | -32 | 50.8 | 110 |
| 100V6-40 | 63 | 2 1/2 | -40 | 63.5 | 134 |
| 100V6-48 | 76 | 3 | -48 | 76.2 | 110 |

V4/V6 Series

High Pressure
DIN – Metric

ParLock Fittings
V4/V6 Series

CA Female Metric 24° Light Series with O-Ring Swivel – Straight

ISO 12151-2-SWS-L – DKOL

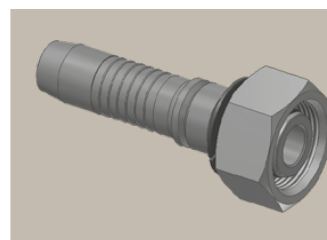
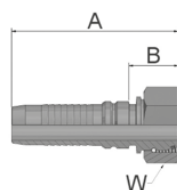

| Part Number | Hose I.D. | | | | Thread metric | Tube O.D. mm | A mm | B mm | W mm |
|-------------|-----------|-------|------|------|------------------|--------------------|---------|---------|---------|
| | DN | Inch | Size | mm | | | | | |
| KCAV4-22-12 | 19 | 3/4 | -12 | 19.1 | M30x2 | 22 | 89 | 28 | 36 |
| KCAV4-28-16 | 25 | 1 | -16 | 25.4 | M36x2 | 28 | 103 | 31 | 41 |
| KCAV4-35-20 | 31 | 1 1/4 | -20 | 31.8 | M45x2 | 35 | 120 | 32 | 50 |
| KCAV6-35-20 | 31 | 1 1/4 | -20 | 31.8 | M45x2 | 35 | 130 | 39 | 50 |
| KCAV4-42-24 | 38 | 1 1/2 | -24 | 38.1 | M52x2 | 42 | 128 | 35 | 60 |
| KCAV6-42-24 | 38 | 1 1/2 | -24 | 38.1 | M52x2 | 42 | 138 | 42 | 60 |

Fittings with standard O-ring seals can be used for temperatures from -40 °C up to +105 °C.
O-rings see section Eb. Special O-rings are available on request.

CE Female Metric 24° Light Series with O-Ring Swivel – 45° Elbow

ISO 12151-2-SWE -L – DKOL 45°

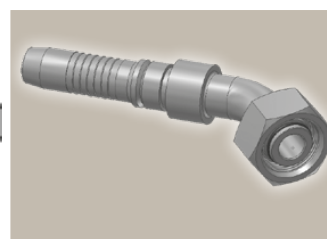
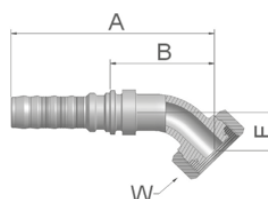

| Part Number | Hose I.D. | | | | Thread metric | Tube O.D. mm | A mm | B mm | E mm | W mm |
|-------------|-----------|-------|------|------|------------------|--------------------|---------|---------|---------|---------|
| | DN | Inch | Size | mm | | | | | | |
| KCEV4-22-12 | 19 | 3/4 | -12 | 19.1 | M30x2 | 22 | 137 | 75 | 29 | 36 |
| KCEV4-35-20 | 31 | 1 1/4 | -20 | 31.8 | M45x2 | 35 | 197 | 109 | 37 | 50 |
| KCEV6-35-20 | 31 | 1 1/4 | -20 | 31.8 | M45x2 | 35 | 188 | 97 | 37 | 50 |
| KCEV6-42-24 | 38 | 1 1/2 | -24 | 38.1 | M52x2 | 42 | 226 | 130 | 49 | 60 |

Fittings with standard O-ring seals can be used for temperatures from -40 °C up to +105 °C.
O-rings see section Eb. Special O-rings are available on request.

Approved **fitting series** for hose types, depending on size: Also available in stainless steel. Details can be found in CAT 4400.1/UK

| | | | | | | | | | | | | | | |
|-----------|-----|-------|--------|--------|-------|-------|-------|-------|--------|---------|-----|-------|-------|------|
| V4 | H31 | H31TC | H31ST | R42 | R42TC | R42ST | R35 | R35TC | RS35TC | R50TC | H29 | H29TC | H29ST | FA35 |
| V6 | R35 | R35TC | RD35TC | RS35TC | R42 | R42ST | R42TC | R50TC | FA35 | CEM69TC | | | | |



Df-2

Catalogue 4400/UK

High Pressure
DIN – Metric

ParLock Fittings
V4/V6 Series

CF Female Metric 24° Light Series with O-Ring Swivel – 90° Elbow

ISO 12151-2-SWE-L – DKOL 90°

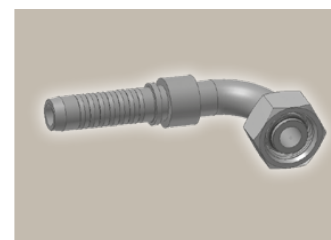
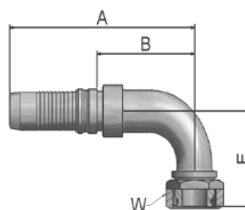

| Part Number | Hose I.D. | | | | Thread metric | Tube O.D. mm | A mm | B mm | E mm | W mm |
|-------------|-----------|-------|------|------|------------------|--------------------|---------|---------|---------|---------|
| | DN | Inch | Size | mm | | | | | | |
| KCFV4-22-16 | 25 | 1 | -16 | 25.4 | M30x2 | 22 | 150 | 77 | 70 | 36 |
| KCFV4-35-20 | 31 | 1 1/4 | -20 | 31.8 | M45x2 | 35 | 186 | 98 | 79 | 50 |
| KCFV6-35-20 | 31 | 1 1/4 | -20 | 31.8 | M45x2 | 35 | 177 | 86 | 79 | 50 |
| KCFV6-42-24 | 38 | 1 1/2 | -24 | 38.1 | M52x2 | 42 | 209 | 113 | 101 | 60 |

Fittings with standard O-ring seals can be used for temperatures from -40 °C up to +105 °C.
O-rings see section Eb. Special O-rings are available on request.

C9 Female Metric 24° – Swivel Heavy Series with O-Ring Straight

ISO 12151-2-SWS-S – DKOS

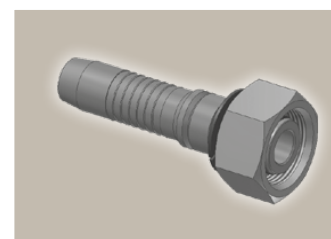
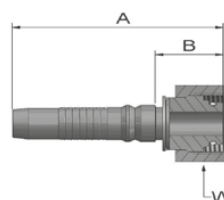

| Part Number | Hose I.D. | | | | Thread metric | Tube O.D. mm | A mm | B mm | W mm |
|-------------|-----------|-------|------|------|------------------|--------------------|---------|---------|---------|
| | DN | Inch | Size | mm | | | | | |
| KC9V4-20-10 | 16 | 5/8 | -10 | 15.9 | M30x2 | 20 | 87 | 27 | 36 |
| KC9V4-20-12 | 19 | 3/4 | -12 | 19.1 | M30x2 | 20 | 88 | 26 | 36 |
| KC9V4-25-12 | 19 | 3/4 | -12 | 19.1 | M36x2 | 25 | 91 | 30.3 | 46 |
| KC9V4-30-12 | 19 | 3/4 | -12 | 19.1 | M42x2 | 30 | 95 | 33 | 50 |
| KC9V4-25-16 | 25 | 1 | -16 | 25.4 | M36x2 | 25 | 103 | 30 | 46 |
| KC9V4-30-16 | 25 | 1 | -16 | 25.4 | M42x2 | 30 | 108 | 35 | 50 |
| KC9V4-38-16 | 25 | 1 | -16 | 25.4 | M52x2 | 38 | 110 | 37 | 60 |
| KC9V4-30-20 | 31 | 1 1/4 | -20 | 31.8 | M42x2 | 30 | 123 | 35 | 50 |
| KC9V4-38-20 | 31 | 1 1/4 | -20 | 31.8 | M52x2 | 38 | 126 | 38 | 60 |
| KC9V6-30-20 | 31 | 1 1/4 | -20 | 31.8 | M42x2 | 30 | 131.5 | 41.5 | 50 |
| KC9V6-38-20 | 31 | 1 1/4 | -20 | 31.8 | M52x2 | 38 | 135 | 44 | 60 |
| KC9V4-38-24 | 38 | 1 1/2 | -24 | 38.1 | M52x2 | 38 | 129 | 36 | 60 |
| KC9V6-38-24 | 38 | 1 1/2 | -24 | 38.1 | M52x2 | 38 | 139 | 43 | 60 |
| KC9V6-54-32 | 51 | 2 | -32 | 50.8 | M68x2 | 54 | 175 | 65 | 80 |

Fittings with standard O-ring seals can be used for temperatures from -40 °C up to +105 °C.
O-rings see section Eb. Special O-rings are available on request.

Approved **fitting series** for hose types, depending on size: Also available in stainless steel. Details can be found in CAT 4400.1/UK

| | | | | | | | | | | | | | | |
|-----------|-----|-------|--------|--------|-------|-------|-------|-------|--------|---------|-----|-------|-------|------|
| V4 | H31 | H31TC | H31ST | R42 | R42TC | R42ST | R35 | R35TC | RS35TC | R50TC | H29 | H29TC | H29ST | FA35 |
| V6 | R35 | R35TC | RD35TC | RS35TC | R42 | R42ST | R42TC | R50TC | FA35 | CEM69TC | | | | |



Df-3

Catalogue 4400/UK

V4/V6 Series

0C Female Metric 24° – Swivel Heavy Series with O-Ring 45° Elbow

ISO 12151-2 – SWE -S – DKOS 45°

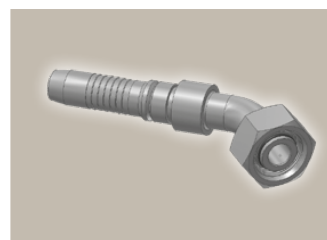
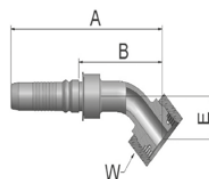

| Part Number | Hose I.D. | | | | Thread metric | Tube O.D. mm | A mm | B mm | E mm | W mm |
|-------------|-----------|-------|------|------|------------------|--------------------|---------|---------|---------|---------|
| | DN | Inch | Size | mm | | | | | | |
| KOCV4-20-10 | 16 | 5/8 | -10 | 15.9 | M30x2 | 20 | 124 | 65 | 26 | 36 |
| KOCV4-20-12 | 19 | 3/4 | -12 | 19.1 | M30x2 | 20 | 138 | 76 | 30 | 36 |
| KOCV4-25-12 | 19 | 3/4 | -12 | 19.1 | M36x2 | 25 | 137 | 76 | 29 | 46 |
| KOCV4-25-16 | 25 | 1 | -16 | 25.4 | M36x2 | 25 | 161 | 88 | 33 | 46 |
| KOCV4-30-16 | 25 | 1 | -16 | 25.4 | M42x2 | 30 | 162 | 88.7 | 33 | 50 |
| KOCV4-30-20 | 31 | 1 1/4 | -20 | 31.8 | M42x2 | 30 | 193 | 105 | 34 | 50 |
| KOCV4-38-20 | 31 | 1 1/4 | -20 | 31.8 | M52x2 | 38 | 197 | 108.7 | 37 | 60 |
| KOCV6-30-20 | 31 | 1 1/4 | -20 | 31.8 | M42x2 | 30 | 184 | 93 | 34 | 50 |
| KOCV6-38-20 | 31 | 1 1/4 | -20 | 31.8 | M52x2 | 38 | 187 | 96.3 | 37 | 60 |
| KOCV4-38-24 | 38 | 1 1/2 | -24 | 38.1 | M52x2 | 38 | 227 | 133 | 49 | 60 |
| KOCV6-38-24 | 38 | 1 1/2 | -24 | 38.1 | M52x2 | 38 | 226 | 130 | 49 | 60 |

Fittings with standard O-ring seals can be used for temperatures from -40 °C up to +105 °C.
O-rings see section Eb. Special O-rings are available on request.

1C Female Metric 24° – Swivel Heavy Series with O-Ring 90° Elbow

ISO 12151-2-SWE-S – DKOS 90°

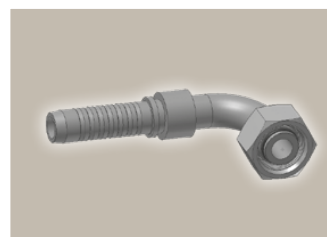
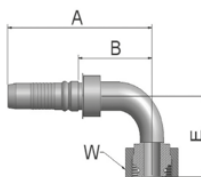

| Part Number | Hose I.D. | | | | Thread metric | Tube O.D. mm | A mm | B mm | E mm | W mm |
|-------------|-----------|-------|------|------|------------------|--------------------|---------|---------|---------|---------|
| | DN | Inch | Size | mm | | | | | | |
| K1CV4-20-10 | 16 | 5/8 | -10 | 15.9 | M30x2 | 20 | 112 | 52.3 | 50 | 36 |
| K1CV4-20-12 | 19 | 3/4 | -12 | 19.1 | M30x2 | 20 | 125 | 63 | 60 | 36 |
| K1CV4-25-12 | 19 | 3/4 | -12 | 19.1 | M36x2 | 25 | 126 | 65 | 59 | 46 |
| K1CV4-25-16 | 25 | 1 | -16 | 25.4 | M36x2 | 25 | 150 | 77 | 69 | 46 |
| K1CV4-30-16 | 25 | 1 | -16 | 25.4 | M42x2 | 30 | 151 | 77.7 | 69 | 50 |
| K1CV4-38-16 | 25 | 1 | -16 | 25.4 | M52x2 | 38 | 150 | 77 | 68 | 60 |
| K1CV4-30-20 | 31 | 1 1/4 | -20 | 31.8 | M42x2 | 30 | 183 | 95 | 73 | 50 |
| K1CV4-38-20 | 31 | 1 1/4 | -20 | 31.8 | M52x2 | 38 | 187 | 98.7 | 78 | 60 |
| K1CV6-30-20 | 31 | 1 1/4 | -20 | 31.8 | M42x2 | 30 | 169 | 78 | 69 | 50 |
| K1CV6-38-20 | 31 | 1 1/4 | -20 | 31.8 | M52x2 | 38 | 177 | 86.3 | 78 | 60 |
| K1CV4-38-24 | 38 | 1 1/2 | -24 | 38.1 | M52x2 | 38 | 210 | 117 | 101 | 60 |
| K1CV6-38-24 | 38 | 1 1/2 | -24 | 38.1 | M52x2 | 38 | 209 | 113 | 101 | 60 |

Fittings with standard O-ring seals can be used for temperatures from -40 °C up to +105 °C.
O-rings see section Eb. Special O-rings are available on request.

Approved **fitting series** for hose types, depending on size: Also available in stainless steel. Details can be found in CAT 4400.1/UK

| | |
|-----------|-----------------------------------------------------------------------------|
| V4 | H31 H31TC H31ST R42 R42TC R42ST R35 R35TC RS35TC R50TC H29 H29TC H29ST FA35 |
| V6 | R35 R35TC RD35TC RS35TC R42 R42ST R42TC R50TC FA35 CEM69TC |



High Pressure
DIN – Metric

ParLock Fittings
V4/V6 Series

D2 **Male Metric 24° – Rigid Heavy Series – Straight**
ISO 12151-2-S-S – CES

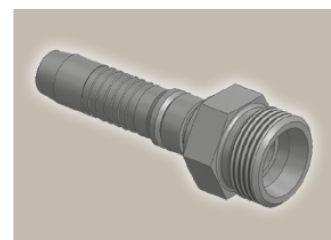
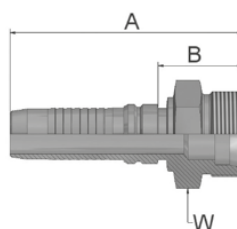

| Part Number | Hose I.D. | | | | Thread metric | Tube O.D. mm | A mm | B mm | H mm |
|-------------|---------------|-------|------|------|----------------------|--------------------|---------|---------|-------------|
| | DN | Inch | Size | mm | | | | | |
| KD2V4-20-12 | 19 | 3/4 | -12 | 19.1 | M30x2 | 20 | 96 | 34 | 30 |
| KD2V4-25-12 | 19 | 3/4 | -12 | 19.1 | M36x2 | 25 | 98 | 36.3 | 36 |
| KD2V4-25-16 | 25 | 1 | -16 | 25.4 | M36x2 | 25 | 110.3 | 37.7 | 46 |
| KD2V4-30-16 | 25 | 1 | -16 | 25.4 | M42x2 | 30 | 115 | 41.7 | 46 |
| KD2V4-38-20 | 31 | 1 1/4 | -20 | 31.8 | M52x2 | 38 | 135 | 46.7 | 55 |
| KD2V6-30-20 | 31 | 1 1/4 | -20 | 31.8 | M42x2 | 30 | 140 | 59 | 46 |
| KD2V6-38-20 | 31 | 1 1/4 | -20 | 31.8 | M52x2 | 38 | 142 | 51 | 55 |
| KD2V4-38-24 | 38 | 1 1/2 | -24 | 38.1 | M52x2 | 38 | 139 | 46 | 55 |
| KD2V6-38-24 | 38 | 1 1/2 | -24 | 38.1 | M52x2 | 38 | 151 | 55 | 55 |

V4/V6 Series

Approved **fitting series** for hose types, depending on size: Also available in stainless steel. Details can be found in CAT 4400.1/UK

| | | | | | | | | | | | | | | |
|-----------|-----|-------|--------|--------|-------|-------|-------|-------|--------|---------|-----|-------|-------|------|
| V4 | H31 | H31TC | H31ST | R42 | R42TC | R42ST | R35 | R35TC | RS35TC | R50TC | H29 | H29TC | H29ST | FA35 |
| V6 | R35 | R35TC | RD35TC | RS35TC | R42 | R42ST | R42TC | R50TC | FA35 | CEM69TC | | | | |



Df-5

Catalogue 4400/UK

92 Female BSP Parallel Pipe Swivel – Straight (60° Cone)

BS5200-A – DKR

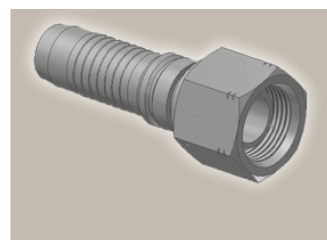
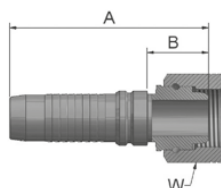

| Part Number | Hose I.D. | | | | Thread BSP | A mm | B mm | W mm |
|-------------|-----------|-------|------|------|---------------|---------|---------|---------|
| | DN | Inch | Size | mm | | | | |
| K92V4-10-10 | 16 | 5/8 | -10 | 15.9 | 5/8x14 | 80 | 20.3 | 30 |
| K92V4-12-12 | 19 | 3/4 | -12 | 19.1 | 3/4x14 | 85 | 23.3 | 32 |
| K92V4-16-12 | 19 | 3/4 | -12 | 19.1 | 1x11 | 93 | 31.3 | 41 |
| K92V4-16-16 | 25 | 1 | -16 | 25.4 | 1x11 | 105 | 32 | 41 |
| K92V4-20-20 | 31 | 1 1/4 | -20 | 31.8 | 1 1/4x11 | 118 | 30 | 50 |
| K92V6-20-20 | 31 | 1 1/4 | -20 | 31.8 | 1 1/4x11 | 127 | 36 | 50 |
| K92V4-24-24 | 38 | 1 1/2 | -24 | 38.1 | 1 1/2x11 | 124 | 30.9 | 55 |
| K92V6-24-24 | 38 | 1 1/2 | -24 | 38.1 | 1 1/2x11 | 134 | 38 | 55 |
| K92V4-32-32 | 51 | 2 | -32 | 50.8 | 2x11 | 131 | 34.2 | 70 |
| K92V6-32-32 | 51 | 2 | -32 | 50.8 | 2x11 | 151 | 41 | 70 |

B1 Female BSP Parallel Pipe Swivel 45° Elbow (60° Cone)

BS 5200-D – DKR 45°

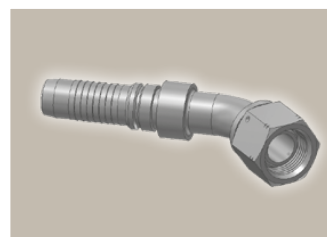
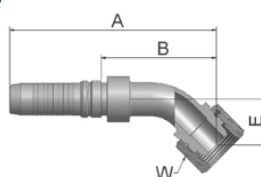

| Part Number | Hose I.D. | | | | Thread BSP | A mm | B mm | E mm | W mm |
|-------------|-----------|-------|------|------|---------------|---------|---------|---------|---------|
| | DN | Inch | Size | mm | | | | | |
| KB1V4-12-12 | 19 | 3/4 | -12 | 19.1 | 3/4x14 | 134 | 72.3 | 26 | 32 |
| KB1V4-16-16 | 25 | 1 | -16 | 25.4 | 1x11 | 164 | 91 | 36 | 41 |
| KB1V4-20-20 | 31 | 1 1/4 | -20 | 31.8 | 1 1/4x11 | 198 | 109.7 | 38 | 50 |
| KB1V6-20-20 | 31 | 1 1/4 | -20 | 31.8 | 1 1/4x11 | 194 | 103 | 43 | 50 |
| KB1V4-24-24 | 38 | 1 1/2 | -24 | 38.1 | 1 1/2x11 | 230 | 137 | 52 | 55 |
| KB1V6-24-24 | 38 | 1 1/2 | -24 | 38.1 | 1 1/2x11 | 229 | 133 | 52 | 55 |
| KB1V4-32-32 | 51 | 2 | -32 | 50.8 | 2x11 | 277 | 180 | 70 | 70 |
| KB1V6-32-32 | 51 | 2 | -32 | 50.8 | 2x11 | 288 | 178 | 70 | 70 |

Approved **fitting series** for hose types, depending on size: Also available in stainless steel. Details can be found in CAT 4400.1/UK

| | | | | | | | | | | | | | | |
|-----------|-----|-------|--------|--------|-------|-------|-------|-------|--------|---------|-----|-------|-------|------|
| V4 | H31 | H31TC | H31ST | R42 | R42TC | R42ST | R35 | R35TC | RS35TC | R50TC | H29 | H29TC | H29ST | FA35 |
| V6 | R35 | R35TC | RD35TC | RS35TC | R42 | R42ST | R42TC | R50TC | FA35 | CEM69TC | | | | |

B2 Female BSP Parallel Pipe Swivel 90° Elbow (60° Cone)

BS 5200-B – DKR 90°

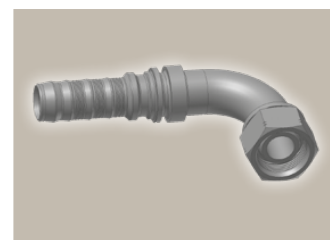
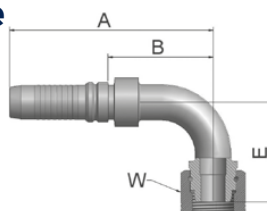

| Part Number | Hose I.D. | | | | Thread BSP | A mm | B mm | E mm | W mm |
|-------------|-----------|-------|------|------|---------------|---------|---------|---------|---------|
| | DN | Inch | Size | mm | | | | | |
| KB2V4-12-12 | 19 | 3/4 | -12 | 19.1 | 3/4x14 | 125 | 63.3 | 55 | 32 |
| KB2V4-16-16 | 25 | 1 | -16 | 25.4 | 1x11 | 150 | 77 | 74 | 41 |
| KB2V4-20-20 | 31 | 1 1/4 | -20 | 31.8 | 1 1/4x11 | 186 | 98.7 | 80 | 50 |
| KB2V6-20-20 | 31 | 1 1/4 | -20 | 31.8 | 1 1/4x11 | 177 | 86 | 80 | 50 |
| KB2V4-24-24 | 38 | 1 1/2 | -24 | 38.1 | 1 1/2x11 | 210 | 116.9 | 103 | 55 |
| KB2V6-24-24 | 38 | 1 1/2 | -24 | 38.1 | 1 1/2x11 | 209 | 113 | 103 | 55 |
| KB2V4-32-32 | 51 | 2 | -32 | 50.8 | 2x11 | 257 | 160 | 149 | 70 |
| KB2V6-32-32 | 51 | 2 | -32 | 50.8 | 2x11 | 268 | 157 | 149 | 70 |

D9 Male BSP Parallel Pipe Rigid – Straight (60° Cone)

BS5200 – AGR

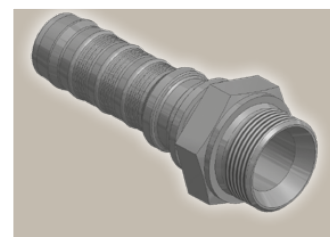
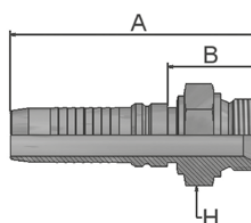

| Part Number | Hose I.D. | | | | Thread BSP | A mm | B mm | H mm |
|-------------|-----------|-------|------|------|---------------|---------|---------|---------|
| | DN | Inch | Size | mm | | | | |
| KD9V4-10-10 | 16 | 5/8 | -10 | 15.9 | 5/8x14 | 94 | 35 | 30 |
| KD9V4-12-12 | 19 | 3/4 | -12 | 19.1 | 3/4x14 | 99 | 37.3 | 32 |
| KD9V4-16-16 | 25 | 1 | -16 | 25.4 | 1x11 | 115 | 42.7 | 41 |
| KD9V4-20-20 | 31 | 1 1/4 | -20 | 31.8 | 1 1/4x11 | 134 | 46.2 | 50 |
| KD9V6-20-20 | 31 | 1 1/4 | -20 | 31.8 | 1 1/4x11 | 139 | 48 | 50 |
| KD9V4-24-24 | 38 | 1 1/2 | -24 | 38.1 | 1 1/2x11 | 142 | 48.4 | 55 |
| KD9V6-24-24 | 38 | 1 1/2 | -24 | 38.1 | 1 1/2x11 | 155 | 58 | 55 |
| KD9V4-32-32 | 51 | 2 | -32 | 50.8 | 2x11 | 148 | 50 | 70 |
| KD9V6-32-32 | 51 | 2 | -32 | 50.8 | 2x11 | 168 | 58 | 70 |

V4/V6 Series

Approved **fitting series** for hose types, depending on size: Also available in stainless steel. Details can be found in CAT 4400.1/UK

| | |
|-----------|-----------------------------------------------------------------------------|
| V4 | H31 H31TC H31ST R42 R42TC R42ST R35 R35TC RS35TC R50TC H29 H29TC H29ST FA35 |
| V6 | R35 R35TC RD35TC RS35TC R42 R42ST R42TC R50TC FA35 CEM69TC |

91 Male BSP Taper Pipe – Rigid Straight

BS5200 – AGR-K

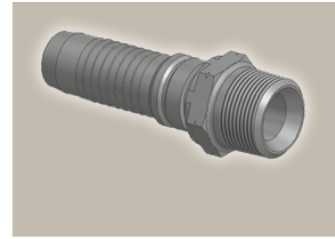
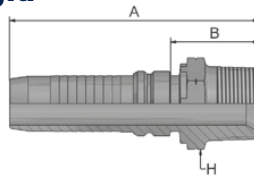

| Part Number | Hose I.D. | | | | Thread BSP | A mm | B mm | H mm |
|-------------|-----------|-------|------|------|---------------|---------|---------|---------|
| | DN | Inch | Size | mm | | | | |
| K91V4-12-12 | 19 | 3/4 | -12 | 19.1 | 3/4x14 | 99 | 37 | 30 |
| K91V4-16-16 | 25 | 1 | -16 | 25.4 | 1x11 | 113 | 40 | 36 |
| K91V4-20-20 | 31 | 1 1/4 | -20 | 31.8 | 1 1/4x11 | 138 | 50 | 46 |
| K91V4-24-24 | 38 | 1 1/2 | -24 | 38.1 | 1 1/2x11 | 144 | 59 | 55 |
| K91V4-32-32 | 51 | 2 | -32 | 50.8 | 2x11 | 154 | 56 | 65 |

Approved **fitting series** for hose types, depending on size: Also available in stainless steel. Details can be found in CAT 4400.1/UK

V4 H31 H31TC H31ST R42 R42TC R42ST R35 R35TC RS35TC R50TC H29 H29TC H29ST FA35

V6 R35 R35TC RD35TC RS35TC R42 R42ST R42TC R50TC FA35 CEM69TC



01 Male NPTF Pipe Rigid – Straight

SAE J476A / J516 – AGN

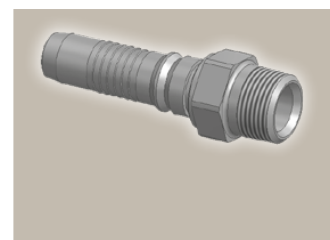
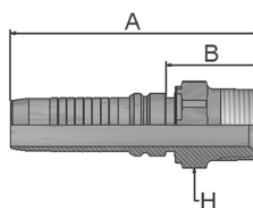

| Part Number | Hose I.D. | | | | Thread NPTF | A mm | B mm | H mm |
|-------------|-----------|-------|------|------|----------------|---------|---------|---------|
| | DN | Inch | Size | mm | | | | |
| K01V4-12-12 | 19 | 3/4 | -12 | 19.1 | 3/4-14 | 100 | 38.3 | 30 |
| K01V4-16-16 | 25 | 1 | -16 | 25.4 | 1-11 1/2 | 116.5 | 43.9 | 36 |
| K01V4-20-20 | 31 | 1 1/4 | -20 | 31.8 | 1 1/4-11 1/2 | 146 | 58.2 | 46 |
| K01V6-20-20 | 31 | 1 1/4 | -20 | 31.8 | 1 1/4-11 1/2 | 151 | 60.2 | 46 |
| K01V4-24-24 | 38 | 1 1/2 | -24 | 38.1 | 1 1/2-11 1/2 | 148.4 | 55.3 | 50 |
| K01V6-24-24 | 38 | 1 1/2 | -24 | 38.1 | 1 1/2-11 1/2 | 159 | 62.7 | 50 |
| K01V4-32-32 | 51 | 2 | -32 | 50.8 | 2-11 1/2 | 159.8 | 62.3 | 65 |
| K01V6-32-32 | 51 | 2 | -32 | 50.8 | 2-11 1/2 | 181 | 70 | 65 |

03 Male JIC 37° – Rigid Straight

ISO12151-5-S – AGJ

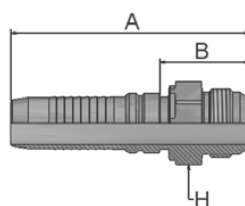

| Part Number | Hose I.D. | | | | Thread UNF | A mm | B mm | H mm |
|-------------|-----------|-------|------|------|---------------|---------|---------|---------|
| | DN | Inch | Size | mm | | | | |
| K03V4-12-12 | 19 | 3/4 | -12 | 19.1 | 1 1/16x12 | 101 | 39.3 | 30 |
| K03V4-16-12 | 19 | 3/4 | -12 | 19.1 | 1 5/16x12 | 103 | 41.3 | 36 |
| K03V4-16-16 | 25 | 1 | -16 | 25.4 | 1 5/16x12 | 117 | 44.1 | 36 |
| K03V4-20-16 | 25 | 1 | -16 | 25.4 | 1 5/8x12 | 122 | 49.5 | 46 |
| K03V4-20-20 | 31 | 1 1/4 | -20 | 31.8 | 1 5/8x12 | 139 | 50.7 | 46 |
| K03V4-24-20 | 31 | 1 1/4 | -20 | 31.8 | 1 7/8x12 | 139 | 51 | 50 |
| K03V6-20-20 | 31 | 1 1/4 | -20 | 31.8 | 1 5/8x12 | 147 | 56 | 46 |
| K03V4-24-24 | 38 | 1 1/2 | -24 | 38.1 | 1 7/8x12 | 146 | 52.6 | 50 |
| K03V6-24-24 | 38 | 1 1/2 | -24 | 38.1 | 1 7/8x12 | 156 | 60 | 50 |
| K03V4-32-32 | 51 | 2 | -32 | 50.8 | 2 1/2x12 | 161 | 64 | 65 |
| K03V6-32-32 | 51 | 2 | -32 | 50.8 | 2 1/2x12 | 182 | 72 | 65 |

V4/V6 Series

Approved **fitting series** for hose types, depending on size: Also available in stainless steel. Details can be found in CAT 4400.1/UK

| | | | | | | | | | | | | | | |
|-----------|-----|-------|--------|--------|-------|-------|-------|-------|--------|---------|-----|-------|-------|------|
| V4 | H31 | H31TC | H31ST | R42 | R42TC | R42ST | R35 | R35TC | RS35TC | R50TC | H29 | H29TC | H29ST | FA35 |
| V6 | R35 | R35TC | RD35TC | RS35TC | R42 | R42ST | R42TC | R50TC | FA35 | CEM69TC | | | | |



06 Female JIC 37° – Swivel Straight

ISO12151-5-SWS – DKJ

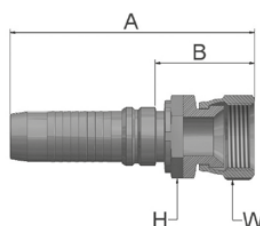

| Part Number | Hose I.D. | | | | Thread UNF | A mm | B mm | H mm | W mm |
|-------------|-----------|-------|------|------|---------------|---------|---------|---------|---------|
| | DN | Inch | Size | mm | | | | | |
| K06V4-12-12 | 19 | 3/4 | -12 | 19.1 | 1 1/16x12 | 105 | 43 | 30 | 32 |
| K06V4-16-12 | 19 | 3/4 | -12 | 19.1 | 1 5/16x12 | 109 | 48 | 36 | 41 |
| K06V4-16-16 | 25 | 1 | -16 | 25.4 | 1 5/16x12 | 122 | 50 | 36 | 41 |
| K06V4-20-16 | 25 | 1 | -16 | 25.4 | 1 5/8x12 | 125 | 52 | 41 | 50 |
| K06V4-20-20 | 31 | 1 1/4 | -20 | 31.8 | 1 5/8x12 | 146 | 58 | 46 | 50 |
| K06V4-24-20 | 31 | 1 1/4 | -20 | 31.8 | 1 7/8x12 | 150 | 63 | 50 | 60 |
| K06V6-20-20 | 31 | 1 1/4 | -20 | 31.8 | 1 5/8x12 | 154 | 63 | 46 | 50 |
| K06V6-24-20 | 31 | 1 1/4 | -20 | 31.8 | 1 7/8x12 | 159 | 68 | 50 | 60 |
| K06V4-24-24 | 38 | 1 1/2 | -24 | 38.1 | 1 7/8x12 | 152 | 59 | 50 | 60 |
| K06V6-24-24 | 38 | 1 1/2 | -24 | 38.1 | 1 7/8x12 | 163 | 67 | 50 | 60 |
| K06V4-32-32 | 51 | 2 | -32 | 50.8 | 2 1/2x12 | 168 | 70 | 65 | 75 |
| K06V6-32-32 | 51 | 2 | -32 | 50.8 | 2 1/2x12 | 188 | 77 | 65 | 75 |

37 Female JIC 37° – Swivel 45° Elbow

ISO 12151-5-SWE 45° – DKJ 45°

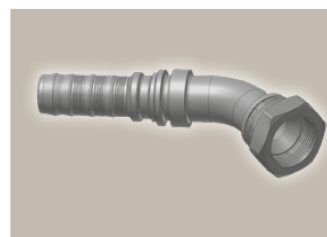
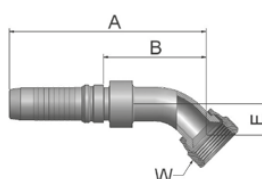

| Part Number | Hose I.D. | | | | Thread UNF | A mm | B mm | E mm | W mm |
|-------------|-----------|-------|------|------|---------------|---------|---------|---------|---------|
| | DN | Inch | Size | mm | | | | | |
| K37V4-12-12 | 19 | 3/4 | -12 | 19.1 | 1 1/16x12 | 129 | 67 | 22 | 32 |
| K37V4-16-16 | 25 | 1 | -16 | 25.4 | 1 5/16x12 | 152 | 79.7 | 24 | 41 |
| K37V4-20-20 | 31 | 1 1/4 | -20 | 31.8 | 1 5/8x12 | 201 | 113 | 42 | 50 |
| K37V6-20-20 | 31 | 1 1/4 | -20 | 31.8 | 1 5/8x12 | 192 | 101 | 42 | 50 |
| K37V4-24-24 | 38 | 1 1/2 | -24 | 38.1 | 1 7/8x12 | 227 | 133.9 | 49 | 60 |
| K37V6-24-24 | 38 | 1 1/2 | -24 | 38.1 | 1 7/8x12 | 235 | 139 | 58 | 60 |
| K37V4-32-32 | 51 | 2 | -32 | 50.8 | 2 1/2x12 | 279 | 182 | 72 | 75 |
| K37V6-32-32 | 51 | 2 | -32 | 50.8 | 2 1/2x12 | 290 | 180 | 72 | 75 |

Approved **fitting series** for hose types, depending on size: Also available in stainless steel. Details can be found in CAT 4400.1/UK

| | | | | | | | | | | | | | | |
|-----------|-----|-------|--------|--------|-------|-------|-------|-------|--------|---------|-----|-------|-------|------|
| V4 | H31 | H31TC | H31ST | R42 | R42TC | R42ST | R35 | R35TC | RS35TC | R50TC | H29 | H29TC | H29ST | FA35 |
| V6 | R35 | R35TC | RD35TC | RS35TC | R42 | R42ST | R42TC | R50TC | FA35 | CEM69TC | | | | |







Df-10

Catalogue 4400/UK

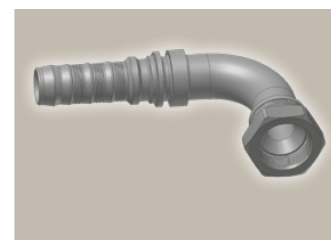
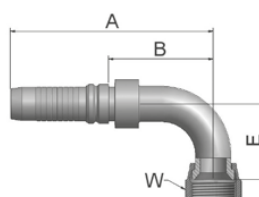
39 Female JIC 37° – Swivel 90° Elbow

ISO 12151-5-SWES – DKJ 90°



| Part Number |  Hose I.D. | | | |  Thread UNF | A mm | B mm | E mm |  W mm |
|-------------|------------------------------------------------------------------------------------------------|-------|------|------|----------------------------------------------------------------------------------------------------|---------|---------|---------|------------------------------------------------------------------------------------------------|
| | DN | Inch | Size | mm | | | | | |
| K39V4-12-12 | 19 | 3/4 | -12 | 19.1 | 1 1/16x12 | 125 | 63.3 | 48 | 32 |
| K39V4-16-12 | 19 | 3/4 | -12 | 19.1 | 1 5/16x12 | 125 | 63.3 | 56 | 41 |
| K39V4-16-16 | 25 | 1 | -16 | 25.4 | 1 5/16x12 | 150 | 77.7 | 56 | 41 |
| K39V4-20-16 | 25 | 1 | -16 | 25.4 | 1 5/8x12 | 150 | 77 | 62 | 50 |
| K39V4-20-20 | 31 | 1 1/4 | -20 | 31.8 | 1 5/8x12 | 186 | 98 | 85 | 50 |
| K39V4-24-20 | 31 | 1 1/4 | -20 | 31.8 | 1 7/8x12 | 186 | 98 | 80 | 60 |
| K39V6-20-20 | 31 | 1 1/4 | -20 | 31.8 | 1 5/8x12 | 177 | 86 | 85 | 50 |
| K39V4-24-24 | 38 | 1 1/2 | -24 | 38.1 | 1 7/8x12 | 210 | 116.9 | 102 | 60 |
| K39V6-24-24 | 38 | 1 1/2 | -24 | 38.1 | 1 7/8x12 | 209 | 113 | 102 | 60 |
| K39V4-32-32 | 51 | 2 | -32 | 50.8 | 2 1/2x12 | 257 | 160 | 152 | 75 |
| K39V6-32-32 | 51 | 2 | -32 | 50.8 | 2 1/2x12 | 268 | 157 | 152 | 75 |

V4/V6 Series

Approved **fitting series** for hose types, depending on size: Also available in stainless steel. Details can be found in CAT 4400.1/UK

| | |
|-----------|-----------------------------------------------------------------------------|
| V4 | H31 H31TC H31ST R42 R42TC R42ST R35 R35TC RS35TC R50TC H29 H29TC H29ST FA35 |
| V6 | R35 R35TC RD35TC RS35TC R42 R42ST R42TC R50TC FA35 CEM69TC |



15/4A ISO 6162-1-Flange Straight

ISO 12151-3-S-L – SFL
(35.0 MPa/ 5000 psi)

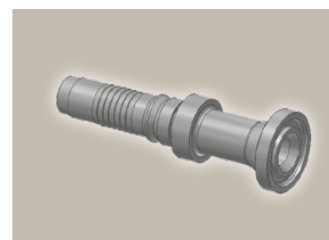
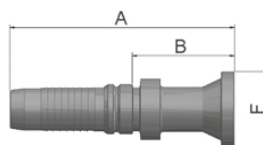

| Part Number | Hose I.D. | | | | Flange Inch | A mm | B mm | F mm |
|-------------|-----------|-------|------|------|----------------|---------|---------|---------|
| | DN | Inch | Size | mm | | | | |
| K15V4-12-12 | 19 | 3/4 | -12 | 19.1 | 3/4 | 119 | 58 | 38 |
| K15V4-16-12 | 19 | 3/4 | -12 | 19.1 | 1 | 100 | 38.3 | 45 |
| K15V4-12-16 | 25 | 1 | -16 | 25.4 | 3/4 | 134.8 | 62.2 | 38 |
| K15V4-16-16 | 25 | 1 | -16 | 25.4 | 1 | 133 | 61 | 45 |
| K4AV4-20-16 | 25 | 1 | -16 | 25.4 | 1 1/4 | 101 | 28 | 51 |
| K15V4-16-20 | 31 | 1 1/4 | -20 | 31.8 | 1 | 152 | 64 | 45 |
| K4AV4-20-20 | 31 | 1 1/4 | -20 | 31.8 | 1 1/4 | 160 | 72 | 51 |
| K4AV4-24-20 | 31 | 1 1/4 | -20 | 31.8 | 1 1/2 | 126 | 38.7 | 60 |
| K15V6-16-20 | 31 | 1 1/4 | -20 | 31.8 | 1 | 161 | 70 | 44 |
| K4AV6-20-20 | 31 | 1 1/4 | -20 | 31.8 | 1 1/4 | 167 | 76 | 51 |
| K4AV6-24-20 | 31 | 1 1/4 | -20 | 31.8 | 1 1/2 | 165 | 74 | 60 |
| K4AV4-20-24 | 38 | 1 1/2 | -24 | 38.1 | 1 1/4 | 167 | 73 | 51 |
| K4AV4-24-24 | 38 | 1 1/2 | -24 | 38.1 | 1 1/2 | 190 | 97 | 60 |
| K4AV4-32-24 | 38 | 1 1/2 | -24 | 38.1 | 2 | 149 | 56 | 71 |
| K4AV6-24-24 | 38 | 1 1/2 | -24 | 38.1 | 1 1/2 | 201 | 105 | 60 |
| K4AV6-32-24 | 38 | 1 1/2 | -24 | 38.1 | 2 | 159 | 63 | 71 |
| K4AV4-32-32 | 51 | 2 | -32 | 50.8 | 2 | 189 | 92 | 71 |
| K4AV6-32-32 | 51 | 2 | -32 | 50.8 | 2 | 210 | 100 | 71 |

Approved **fitting series** for hose types, depending on size: Also available in stainless steel. Details can be found in CAT 4400.1/UK

| | | | | | | | | | | | | | | |
|-----------|-----|-------|--------|--------|-------|-------|-------|-------|--------|---------|-----|-------|-------|------|
| V4 | H31 | H31TC | H31ST | R42 | R42TC | R42ST | R35 | R35TC | RS35TC | R50TC | H29 | H29TC | H29ST | FA35 |
| V6 | R35 | R35TC | RD35TC | RS35TC | R42 | R42ST | R42TC | R50TC | FA35 | CEM69TC | | | | |



17/4F ISO 6162-1-Flange 45° Elbow

ISO 12151-3 – E45S – L – SFL 45°
(35.0 MPa/ 5000 psi)

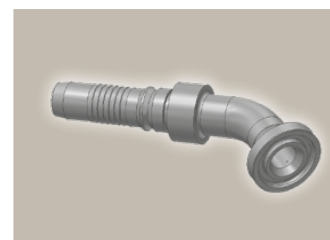
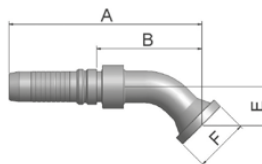

| Part Number | Hose I.D. | | | | Flange Inch | A mm | B mm | E mm | F mm |
|-------------|-----------|-------|------|------|----------------|---------|---------|---------|---------|
| | DN | Inch | Size | mm | | | | | |
| K17V4-12-12 | 19 | 3/4 | -12 | 19.1 | 3/4 | 133 | 72 | 26 | 38 |
| K17V4-16-12 | 19 | 3/4 | -12 | 19.1 | 1 | 133 | 72 | 26 | 45 |
| K4FV4-20-12 | 19 | 3/4 | -12 | 19.1 | 1 1/4 | 133 | 71 | 25 | 51 |
| K17V4-16-16 | 25 | 1 | -16 | 25.4 | 1 | 160 | 87 | 32 | 45 |
| K4FV4-20-16 | 25 | 1 | -16 | 25.4 | 1 1/4 | 160 | 87 | 32 | 51 |
| K17V4-16-20 | 31 | 1 1/4 | -20 | 31.8 | 1 | 198 | 109.7 | 38 | 45 |
| K4FV4-20-20 | 31 | 1 1/4 | -20 | 31.8 | 1 1/4 | 198 | 109.7 | 38 | 51 |
| K4FV4-24-20 | 31 | 1 1/4 | -20 | 31.8 | 1 1/2 | 198 | 109.7 | 38 | 60 |
| K17V6-16-20 | 31 | 1 1/4 | -20 | 31.8 | 1 | 188 | 97 | 38 | 44 |
| K4FV6-20-20 | 31 | 1 1/4 | -20 | 31.8 | 1 1/4 | 188 | 97 | 38 | 51 |
| K4FV6-24-20 | 31 | 1 1/4 | -20 | 31.8 | 1 1/2 | 188 | 97 | 38 | 60 |
| K4FV4-24-24 | 38 | 1 1/2 | -24 | 38.1 | 1 1/2 | 222 | 128.9 | 44 | 60 |
| K4FV4-32-24 | 38 | 1 1/2 | -24 | 38.1 | 2 | 222 | 128.9 | 44 | 71 |
| K4FV6-20-24 | 38 | 1 1/2 | -24 | 38.1 | 1 1/4 | 201 | 105 | 44 | 51 |
| K4FV6-24-24 | 38 | 1 1/2 | -24 | 38.1 | 1 1/2 | 221 | 125 | 44 | 60 |
| K4FV6-32-24 | 38 | 1 1/2 | -24 | 38.1 | 2 | 221 | 125 | 44 | 71 |
| K4FV4-32-32 | 51 | 2 | -32 | 50.8 | 2 | 269 | 171 | 62 | 71 |
| K4FV6-32-32 | 51 | 2 | -32 | 50.8 | 2 | 280 | 169 | 62 | 71 |

V4/V6 Series

Approved **fitting series** for hose types, depending on size: Also available in stainless steel. Details can be found in CAT 4400.1/UK

| | | | | | | | | | | | | | | |
|-----------|-----|-------|--------|--------|-------|-------|-------|-------|--------|---------|-----|-------|-------|------|
| V4 | H31 | H31TC | H31ST | R42 | R42TC | R42ST | R35 | R35TC | RS35TC | R50TC | H29 | H29TC | H29ST | FA35 |
| V6 | R35 | R35TC | RD35TC | RS35TC | R42 | R42ST | R42TC | R50TC | FA35 | CEM69TC | | | | |



19/4N ISO 6162-1-Flange 90° Elbow

ISO 12151-3-E-L – SFL 90°
(35.0 MPa/ 5000 psi)

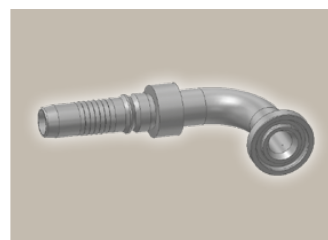
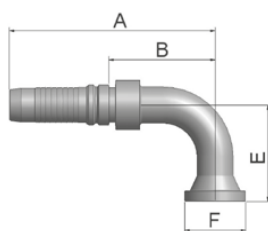

| Part Number | Hose I.D. | | | | Flange Inch | A mm | B mm | E mm | F mm |
|-------------------|-----------|-------|------|------|----------------|---------|---------|---------|---------|
| | DN | Inch | Size | mm | | | | | |
| K19V4-12-12 | 19 | 3/4 | -12 | 19.1 | 3/4 | 125 | 63.3 | 58 | 38 |
| K19V4-16-12 | 19 | 3/4 | -12 | 19.1 | 1 | 125 | 63.3 | 58 | 45 |
| K19V4-16-16 | 25 | 1 | -16 | 25.4 | 1 | 150 | 77.7 | 70 | 45 |
| K4NV4-20-16 | 25 | 1 | -16 | 25.4 | 1 1/4 | 150 | 77 | 69 | 51 |
| K19V4-16-20 | 31 | 1 1/4 | -20 | 31.8 | 1 | 186 | 98 | 90 | 45 |
| K4NV4-20-20 | 31 | 1 1/4 | -20 | 31.8 | 1 1/4 | 186 | 98.2 | 90 | 51 |
| K4NV4-24-20 | 31 | 1 1/4 | -20 | 31.8 | 1 1/2 | 186 | 98 | 90 | 60 |
| K4NV4-24-20-SL110 | 31 | 1 1/4 | -20 | 31.8 | 1 1/2 | 186 | 98 | 110 | 60 |
| K19V6-16-20 | 31 | 1 1/4 | -20 | 31.8 | 1 | 177 | 86 | 90 | 44 |
| K4NV6-20-20 | 31 | 1 1/4 | -20 | 31.8 | 1 1/4 | 177 | 86 | 90 | 51 |
| K4NV6-24-20 | 31 | 1 1/4 | -20 | 31.8 | 1 1/2 | 177 | 86 | 90 | 60 |
| K4NV4-20-24 | 38 | 1 1/2 | -24 | 38.1 | 1 1/4 | 197 | 103 | 104 | 51 |
| K4NV4-24-24 | 38 | 1 1/2 | -24 | 38.1 | 1 1/2 | 210 | 116.9 | 104 | 60 |
| K4NV4-24-24-SL150 | 38 | 1 1/2 | -24 | 38.1 | 1 1/2 | 210 | 116.9 | 150 | 60 |
| K4NV4-24-24-SL200 | 38 | 1 1/2 | -24 | 38.1 | 1 1/2 | 210 | 116.9 | 200 | 60 |
| K4NV4-32-24 | 38 | 1 1/2 | -24 | 38.1 | 2 | 210 | 116.9 | 104 | 71 |
| K4NV6-20-24 | 38 | 1 1/2 | -24 | 38.1 | 1 1/4 | 184 | 88 | 104 | 51 |
| K4NV6-24-24 | 38 | 1 1/2 | -24 | 38.1 | 1 1/2 | 209 | 113 | 104 | 60 |
| K4NV6-32-24 | 38 | 1 1/2 | -24 | 38.1 | 2 | 209 | 113 | 104 | 71 |
| K4NV4-24-32 | 51 | 2 | -32 | 50.8 | 1 1/2 | 227 | 130 | 138 | 60 |
| K4NV4-32-32 | 51 | 2 | -32 | 50.8 | 2 | 257 | 160.2 | 138 | 71 |
| K4NV6-32-32 | 51 | 2 | -32 | 50.8 | 2 | 268 | 157 | 138 | 71 |

Approved **fitting series** for hose types, depending on size: Also available in stainless steel. Details can be found in CAT 4400.1/UK

| | | | | | | | | | | | | | | |
|-----------|-----|-------|--------|--------|-------|-------|-------|-------|--------|---------|-----|-------|-------|------|
| V4 | H31 | H31TC | H31ST | R42 | R42TC | R42ST | R35 | R35TC | RS35TC | R50TC | H29 | H29TC | H29ST | FA35 |
| V6 | R35 | R35TC | RD35TC | RS35TC | R42 | R42ST | R42TC | R50TC | FA35 | CEM69TC | | | | |



6A ISO 6162-2-Flange Straight

ISO 12151-3-S-S – SFS
(42.0 MPa/ 6000 psi)

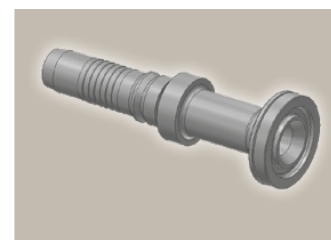
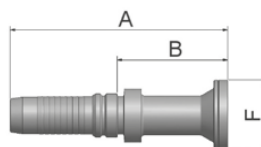

| Part Number | Hose I.D. | | | | Flange Inch | A mm | B mm | F mm |
|-------------|-----------|-------|------|------|----------------|---------|---------|---------|
| | DN | Inch | Size | mm | | | | |
| K6AV4-8-10 | 16 | 5/8 | -10 | 15.9 | 1/2 | 121 | 62 | 32 |
| K6AV4-12-10 | 16 | 5/8 | -10 | 15.9 | 3/4 | 94 | 33.8 | 41 |
| K6AV4-12-12 | 19 | 3/4 | -12 | 19.1 | 3/4 | 126 | 64.4 | 41 |
| K6AV4-16-12 | 19 | 3/4 | -12 | 19.1 | 1 | 100 | 38 | 48 |
| K6AV4-12-16 | 25 | 1 | -16 | 25.4 | 3/4 | 150 | 77 | 41 |
| K6AV4-16-16 | 25 | 1 | -16 | 25.4 | 1 | 148 | 75 | 48 |
| K6AV4-20-16 | 25 | 1 | -16 | 25.4 | 1 1/4 | 116 | 44 | 54 |
| K6AV4-24-16 | 25 | 1 | -16 | 25.4 | 1 1/2 | 118 | 45 | 64 |
| K6AV4-16-20 | 31 | 1 1/4 | -20 | 31.8 | 1 | 166 | 78 | 48 |
| K6AV4-20-20 | 31 | 1 1/4 | -20 | 31.8 | 1 1/4 | 166 | 78 | 54 |
| K6AV4-24-20 | 31 | 1 1/4 | -20 | 31.8 | 1 1/2 | 139 | 51 | 64 |
| K6AV6-16-20 | 31 | 1 1/4 | -20 | 31.8 | 1 | 175 | 84 | 48 |
| K6AV6-20-20 | 31 | 1 1/4 | -20 | 31.8 | 1 1/4 | 175 | 83 | 54 |
| K6AV6-24-20 | 31 | 1 1/4 | -20 | 31.8 | 1 1/2 | 147 | 56 | 64 |
| K6AV4-20-24 | 38 | 1 1/2 | -24 | 38.1 | 1 1/4 | 174 | 81 | 54 |
| K6AV4-24-24 | 38 | 1 1/2 | -24 | 38.1 | 1 1/2 | 192 | 99 | 64 |
| K6AV4-32-24 | 38 | 1 1/2 | -24 | 38.1 | 2 | 184 | 91 | 79 |
| K6AV6-20-24 | 38 | 1 1/2 | -24 | 38.1 | 1 1/4 | 185 | 89 | 54 |
| K6AV6-24-24 | 38 | 1 1/2 | -24 | 38.1 | 1 1/2 | 202 | 106 | 64 |
| K6AV6-32-24 | 38 | 1 1/2 | -24 | 38.1 | 2 | 194 | 98 | 79 |
| K6AV4-24-32 | 51 | 2 | -32 | 50.8 | 1 1/2 | 198 | 101 | 64 |
| K6AV4-32-32 | 51 | 2 | -32 | 50.8 | 2 | 212 | 115 | 79 |
| K6AV6-24-32 | 51 | 2 | -32 | 50.8 | 1 1/2 | 219 | 108.3 | 64 |
| K6AV6-32-32 | 51 | 2 | -32 | 50.8 | 2 | 233 | 122 | 79 |
| K6AV6-32-40 | 63 | 2 1/2 | -40 | 63.5 | 2 | 252 | 117 | 79 |
| K6AV6-40-40 | 63 | 2 1/2 | -40 | 63.5 | 2 1/2 | 253 | 118 | 108 |
| K6AV6-48-40 | 63 | 2 1/2 | -40 | 63.5 | 3 | 250 | 115 | 132 |
| K6AV6-48-48 | 76 | 3 | -48 | 76.2 | 3 | 240 | 133 | 132 |

V4/V6 Series

Approved **fitting series** for hose types, depending on size: Also available in stainless steel. Details can be found in CAT 4400.1/UK

| | |
|-----------|-----------------------------------------------------------------------------|
| V4 | H31 H31TC H31ST R42 R42TC R42ST R35 R35TC RS35TC R50TC H29 H29TC H29ST FA35 |
| V6 | R35 R35TC RD35TC RS35TC R42 R42ST R42TC R50TC FA35 CEM69TC |



6F ISO 6162-2-Flange 45° Elbow – Heavy Series

ISO 12151-3 – E45-S – SFS 45°
(42.0 MPa/ 6000 psi)

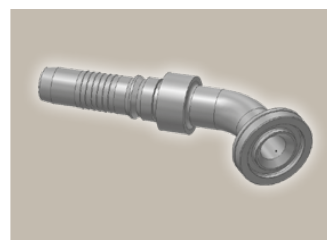
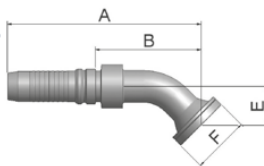

| Part Number | Hose I.D. | | | | Flange Inch | A mm | B mm | E mm | F mm |
|------------------|-----------|-------|------|------|----------------|---------|---------|---------|---------|
| | DN | Inch | Size | mm | | | | | |
| K6FV4-8-10 | 16 | 5/8 | -10 | 15.9 | 1/2 | 123 | 63.3 | 26 | 32 |
| K6FV4-12-10 | 16 | 5/8 | -10 | 15.9 | 3/4 | 123 | 63.3 | 26 | 41 |
| K6FV4-12-12 | 19 | 3/4 | -12 | 19.1 | 3/4 | 133 | 72 | 26 | 41 |
| K6FV4-12-12-SL55 | 19 | 3/4 | -12 | 19.1 | 3/4 | 162 | 101 | 55 | 41 |
| K6FV4-16-12 | 19 | 3/4 | -12 | 19.1 | 1 | 133 | 71.3 | 26 | 48 |
| K6FV4-16-12-SL55 | 19 | 3/4 | -12 | 19.1 | 1 | 162 | 101 | 55 | 48 |
| K6FV4-12-16 | 25 | 1 | -16 | 25.4 | 3/4 | 155 | 78 | 32 | 41 |
| K6FV4-16-16 | 25 | 1 | -16 | 25.4 | 1 | 160 | 87 | 32 | 48 |
| K6FV4-16-16-SL55 | 25 | 1 | -16 | 25.4 | 1 | 183 | 110 | 55 | 48 |
| K6FV4-20-16 | 25 | 1 | -16 | 25.4 | 1 1/4 | 161 | 88.7 | 32 | 54 |
| K6FV4-20-16-SL55 | 25 | 1 | -16 | 25.4 | 1 1/4 | 184 | 112 | 55 | 54 |
| K6FV4-16-20 | 31 | 1 1/4 | -20 | 31.8 | 1 | 198 | 109.7 | 38 | 48 |
| K6FV4-20-20 | 31 | 1 1/4 | -20 | 31.8 | 1 1/4 | 198 | 109.7 | 38 | 54 |
| K6FV4-20-20-SL60 | 31 | 1 1/4 | -20 | 31.8 | 1 1/4 | 220 | 132 | 60 | 54 |
| K6FV4-24-20 | 31 | 1 1/4 | -20 | 31.8 | 1 1/2 | 198 | 109.7 | 38 | 64 |
| K6FV4-24-20-SL60 | 31 | 1 1/4 | -20 | 31.8 | 1 1/2 | 220 | 132 | 60 | 64 |
| K6FV6-16-20 | 31 | 1 1/4 | -20 | 31.8 | 1 | 188 | 97 | 38 | 48 |
| K6FV6-20-20 | 31 | 1 1/4 | -20 | 31.8 | 1 1/4 | 189 | 97.3 | 38 | 54 |
| K6FV6-20-20-SL60 | 31 | 1 1/4 | -20 | 31.8 | 1 1/4 | 210 | 119 | 60 | 54 |
| K6FV6-24-20 | 31 | 1 1/4 | -20 | 31.8 | 1 1/2 | 189 | 97.3 | 38 | 64 |
| K6FV4-24-24 | 38 | 1 1/2 | -24 | 38.1 | 1 1/2 | 222 | 128.9 | 44 | 64 |
| K6FV4-24-24-SL70 | 38 | 1 1/2 | -24 | 38.1 | 1 1/2 | 248 | 155 | 70 | 64 |
| K6FV4-32-24 | 38 | 1 1/2 | -24 | 38.1 | 2 | 222 | 128.9 | 44 | 79 |
| K6FV6-20-24 | 38 | 1 1/2 | -24 | 38.1 | 1 1/4 | 209 | 113.3 | 44 | 54 |
| K6FV6-24-24 | 38 | 1 1/2 | -24 | 38.1 | 1 1/2 | 221 | 125.3 | 44 | 64 |
| K6FV6-24-24-SL70 | 38 | 1 1/2 | -24 | 38.1 | 1 1/2 | 247 | 151 | 70 | 64 |
| K6FV6-32-24 | 38 | 1 1/2 | -24 | 38.1 | 2 | 221 | 125.3 | 44 | 79 |
| K6FV4-32-32 | 51 | 2 | -32 | 50.8 | 2 | 263 | 166 | 56 | 79 |
| K6FV4-32-32-SL70 | 51 | 2 | -32 | 50.8 | 2 | 277 | 180 | 70 | 79 |
| K6FV6-24-32 | 51 | 2 | -32 | 50.8 | 1 1/2 | 260 | 149.3 | 56 | 64 |
| K6FV6-32-32 | 51 | 2 | -32 | 50.8 | 2 | 274 | 163.3 | 56 | 79 |

Approved **fitting series** for hose types, depending on size: Also available in stainless steel. Details can be found in CAT 4400.1/UK

| | | | | | | | | | | | | | | |
|-----------|-----|-------|--------|--------|-------|-------|-------|-------|--------|---------|-----|-------|-------|------|
| V4 | H31 | H31TC | H31ST | R42 | R42TC | R42ST | R35 | R35TC | RS35TC | R50TC | H29 | H29TC | H29ST | FA35 |
| V6 | R35 | R35TC | RD35TC | RS35TC | R42 | R42ST | R42TC | R50TC | FA35 | CEM69TC | | | | |



6N ISO 6162-2-Flange 90° Elbow

ISO 12151-3 – E-S – SFS 90°
(42.0 MPa/ 6000 psi)

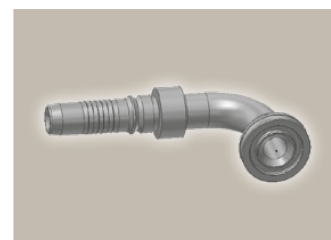
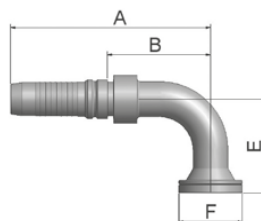

| Part Number | Hose I.D. | | | | Flange Inch | A mm | B mm | E mm | F mm |
|-------------------|-----------|-------|------|------|----------------|---------|---------|---------|---------|
| | DN | Inch | Size | mm | | | | | |
| K6NV4-8-10 | 16 | 5/8 | -10 | 15.9 | 1/2 | 111 | 51 | 54 | 32 |
| K6NV4-12-10 | 16 | 5/8 | -10 | 15.9 | 3/4 | 111 | 50.3 | 54 | 41 |
| K6NV4-12-12 | 19 | 3/4 | -12 | 19.1 | 3/4 | 125 | 63.3 | 58 | 41 |
| K6NV4-12-12-SL100 | 19 | 3/4 | -12 | 19.1 | 3/4 | 125 | 63 | 100 | 41 |
| K6NV4-16-12 | 19 | 3/4 | -12 | 19.1 | 1 | 125 | 63.3 | 58 | 48 |
| K6NV4-16-12-SL100 | 19 | 3/4 | -12 | 19.1 | 1 | 125 | 63 | 100 | 48 |
| K6NV4-12-16 | 25 | 1 | -16 | 25.4 | 3/4 | 140 | 67 | 70 | 41 |
| K6NV4-12-16-SL55 | 25 | 1 | -16 | 25.4 | 3/4 | 140 | 67 | 55 | 41 |
| K6NV4-16-16 | 25 | 1 | -16 | 25.4 | 1 | 150 | 77.7 | 70 | 48 |
| K6NV4-16-16-SL100 | 25 | 1 | -16 | 25.4 | 1 | 150 | 77 | 100 | 48 |
| K6NV4-20-16 | 25 | 1 | -16 | 25.4 | 1 1/4 | 154 | 81 | 70 | 54 |
| K6NV4-20-16-SL115 | 25 | 1 | -16 | 25.4 | 1 1/4 | 154 | 81 | 115 | 54 |
| K6NV4-16-20 | 31 | 1 1/4 | -20 | 31.8 | 1 | 186 | 98.7 | 90 | 48 |
| K6NV4-20-20 | 31 | 1 1/4 | -20 | 31.8 | 1 1/4 | 186 | 98.7 | 90 | 54 |
| K6NV4-20-20-SL120 | 31 | 1 1/4 | -20 | 31.8 | 1 1/4 | 186 | 98 | 120 | 54 |
| K6NV4-20-20-SL330 | 31 | 1 1/4 | -20 | 31.8 | 1 1/4 | 186 | 98 | 330 | 54 |
| K6NV4-24-20 | 31 | 1 1/4 | -20 | 31.8 | 1 1/2 | 186 | 98.7 | 90 | 64 |
| K6NV4-24-20-SL135 | 31 | 1 1/4 | -20 | 31.8 | 1 1/2 | 186 | 98 | 135 | 64 |
| K6NV6-16-20 | 31 | 1 1/4 | -20 | 31.8 | 1 | 177 | 86 | 90 | 48 |
| K6NV6-20-20 | 31 | 1 1/4 | -20 | 31.8 | 1 1/4 | 177 | 86.3 | 90 | 54 |
| K6NV6-20-20-SL120 | 31 | 1 1/4 | -20 | 31.8 | 1 1/4 | 177 | 86 | 120 | 54 |
| K6NV6-24-20 | 31 | 1 1/4 | -20 | 31.8 | 1 1/2 | 177 | 86.3 | 90 | 64 |
| K6NV4-20-24 | 38 | 1 1/2 | -24 | 38.1 | 1 1/4 | 197 | 103.9 | 104 | 54 |
| K6NV4-24-24 | 38 | 1 1/2 | -24 | 38.1 | 1 1/2 | 210 | 116.9 | 104 | 64 |
| K6NV4-24-24-SL140 | 38 | 1 1/2 | -24 | 38.1 | 1 1/2 | 210 | 117 | 140 | 64 |
| K6NV4-24-24-SL160 | 38 | 1 1/2 | -24 | 38.1 | 1 1/2 | 210 | 117 | 160 | 64 |
| K6NV4-24-24-SL200 | 38 | 1 1/2 | -24 | 38.1 | 1 1/2 | 210 | 117 | 200 | 64 |
| K6NV4-32-24 | 38 | 1 1/2 | -24 | 38.1 | 2 | 210 | 116.9 | 104 | 79 |
| K6NV6-20-24 | 38 | 1 1/2 | -24 | 38.1 | 1 1/4 | 192 | 96.3 | 104 | 54 |
| K6NV6-24-24 | 38 | 1 1/2 | -24 | 38.1 | 1 1/2 | 210 | 113.3 | 104 | 64 |
| K6NV6-32-24 | 38 | 1 1/2 | -24 | 38.1 | 2 | 209 | 113.3 | 104 | 79 |
| K6NV4-24-32 | 51 | 2 | -32 | 50.8 | 1 1/2 | 221 | 124 | 104 | 64 |
| K6NV4-32-32 | 51 | 2 | -32 | 50.8 | 2 | 257 | 160 | 138 | 79 |
| K6NV6-24-32 | 51 | 2 | -32 | 50.8 | 1 1/2 | 236 | 125.3 | 104 | 64 |
| K6NV6-32-32 | 51 | 2 | -32 | 50.8 | 2 | 268 | 157.3 | 138 | 79 |

V4/V6 Series

Approved **fitting series** for hose types, depending on size: Also available in stainless steel. Details can be found in CAT 4400.1/UK

| | | | | | | | | | | | | | | |
|-----------|-----|-------|--------|--------|-------|-------|-------|-------|--------|---------|-----|-------|-------|------|
| V4 | H31 | H31TC | H31ST | R42 | R42TC | R42ST | R35 | R35TC | RS35TC | R50TC | H29 | H29TC | H29ST | FA35 |
| V6 | R35 | R35TC | RD35TC | RS35TC | R42 | R42ST | R42TC | R50TC | FA35 | CEM69TC | | | | |



8A Flange – Straight

8000 psi

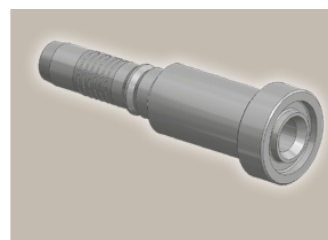
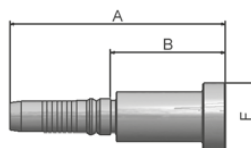

| Part Number | Hose I.D. | | | | Flange Inch | A mm | B mm | F mm |
|-------------|-----------|-------|------|------|----------------|---------|---------|---------|
| | DN | Inch | Size | mm | | | | |
| K8AV4-12-10 | 16 | 5/8 | -10 | 15.9 | 3/4 | 130 | 71 | 41 |
| K8AV4-12-12 | 19 | 3/4 | -12 | 19.1 | 3/4 | 132 | 71 | 41 |
| K8AV4-16-12 | 19 | 3/4 | -12 | 19.1 | 1 | 143 | 82 | 48 |
| K8AV4-16-16 | 25 | 1 | -16 | 25.4 | 1 | 148 | 75 | 48 |
| K8AV4-20-16 | 25 | 1 | -16 | 25.4 | 1 1/4 | 111 | 39 | 54 |
| K8AV6-20-20 | 31 | 1 1/4 | -20 | 31.8 | 1 1/4 | 190 | 88 | 54 |

8F Flange – 45° Elbow

8000 psi

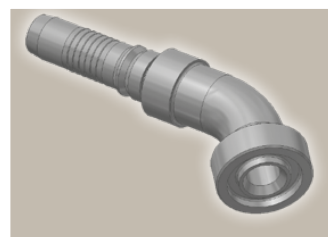
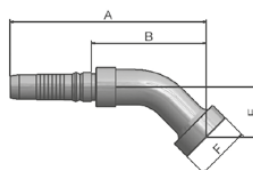

| Part Number | Hose I.D. | | | | Flange Inch | A mm | B mm | E mm | F mm |
|-------------|-----------|-------|------|------|----------------|---------|---------|---------|---------|
| | DN | Inch | Size | mm | | | | | |
| K8FV4-12-10 | 16 | 5/8 | -10 | 15.9 | 3/4 | 123 | 64 | 26 | 41 |
| K8FV4-12-12 | 19 | 3/4 | -12 | 19.1 | 3/4 | 138 | 76 | 26 | 41 |
| K8FV4-16-12 | 19 | 3/4 | -12 | 19.1 | 1 | 143 | 81 | 32 | 48 |
| K8FV4-16-16 | 25 | 1 | -16 | 25.4 | 1 | 178 | 105 | 35 | 48 |
| K8FV4-20-16 | 25 | 1 | -16 | 25.4 | 1 1/4 | 178 | 105 | 35 | 54 |
| K8FV6-20-20 | 31 | 1 1/4 | -20 | 31.8 | 1 1/4 | 194 | 103 | 38 | 54 |

Approved **fitting series** for hose types, depending on size: Also available in stainless steel. Details can be found in CAT 4400.1/UK

| | | | | | | | | | | | | | | |
|-----------|-----|-------|--------|--------|-------|-------|-------|-------|--------|---------|-----|-------|-------|------|
| V4 | H31 | H31TC | H31ST | R42 | R42TC | R42ST | R35 | R35TC | RS35TC | R50TC | H29 | H29TC | H29ST | FA35 |
| V6 | R35 | R35TC | RD35TC | RS35TC | R42 | R42ST | R42TC | R50TC | FA35 | CEM69TC | | | | |

8N Flange – 90° Elbow

8000 psi

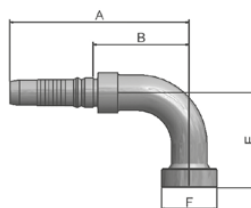

| Part Number | Hose I.D. | | | | Flange Inch | A mm | B mm | E mm | F mm |
|-------------|-----------|-------|------|------|----------------|---------|---------|---------|---------|
| | DN | Inch | Size | mm | | | | | |
| K8NV4-12-10 | 16 | 5/8 | -10 | 15.9 | 3/4 | 111 | 51 | 58 | 41 |
| K8NV4-12-12 | 19 | 3/4 | -12 | 19.1 | 3/4 | 133 | 71 | 70 | 41 |
| K8NV4-16-12 | 19 | 3/4 | -12 | 19.1 | 1 | 133 | 71 | 70 | 48 |
| K8NV4-16-16 | 25 | 1 | -16 | 25.4 | 1 | 170 | 97 | 75 | 48 |
| K8NV4-20-16 | 25 | 1 | -16 | 25.4 | 1 1/4 | 170 | 97 | 90 | 54 |
| K8NV6-20-20 | 31 | 1 1/4 | -20 | 31.8 | 1 1/4 | 182 | 91 | 90 | 54 |

X5 Flange – Straight

Full flange system for
ISO 6162-1 or ISO 6162-2

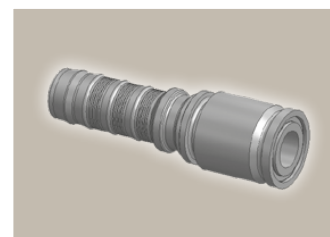
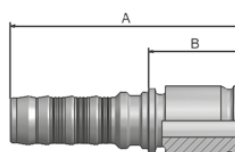

| Part Number | Hose I.D. | | | | Flange Inch | A mm | B mm |
|-------------|-----------|-------|------|------|----------------|---------|---------|
| | DN | Inch | Size | mm | | | |
| KX5V6-20-20 | 31 | 1 1/4 | -20 | 31.8 | 1 1/4 | 152.3 | 61.3 |
| KX5V6-24-24 | 38 | 1 1/2 | -24 | 38.1 | 1 1/2 | 159.3 | 63.3 |
| KX5V6-32-32 | 51 | 2 | -32 | 50.8 | 2 | 188 | 78 |
| KX5V6-40-40 | 63 | 2 1/2 | -40 | 63.5 | 2 1/2 | 233 | 83 |
| KX5V6-48-40 | 63 | 2 1/2 | -40 | 63.5 | 3 | 233 | 98 |

V4/V6 Series

Approved **fitting series** for hose types, depending on size: Also available in stainless steel. Details can be found in CAT 4400.1/UK

| | |
|-----------|-----------------------------------------------------------------------------|
| V4 | H31 H31TC H31ST R42 R42TC R42ST R35 R35TC RS35TC R50TC H29 H29TC H29ST FA35 |
| V6 | R35 R35TC RD35TC RS35TC R42 R42ST R42TC R50TC FA35 CEM69TC |

High Pressure
Flange

ParLock Fittings
V4/V6 Series

X7 Flange - 45° Elbow

Full flange system for
ISO 6162-1 or ISO 6162-2

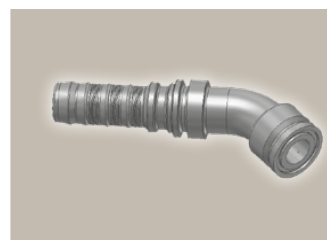
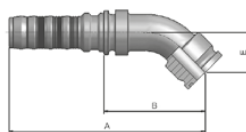

| Part Number | Hose I.D. | | | | Flange Inch | A mm | B mm | E mm |
|-------------|-----------|-------|------|------|----------------|---------|---------|---------|
| | DN | Inch | Size | mm | | | | |
| KX7V6-20-20 | 31 | 1 1/4 | -20 | 31.8 | 1 1/4 | 190 | 99 | 39 |
| KX7V6-24-24 | 38 | 1 1/2 | -24 | 38.1 | 1 1/2 | 221 | 125 | 44 |
| KX7V6-32-32 | 51 | 2 | -32 | 50.8 | 2 | 275 | 164.5 | 57 |

X9 Flange - 90° Elbow

Full flange system for
ISO 6162-1 or ISO 6162-2

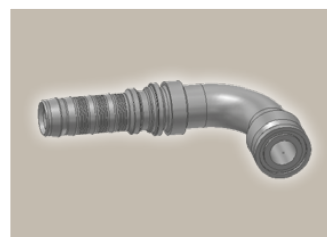
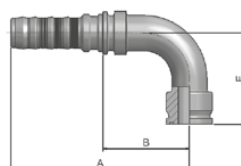

| Part Number | Hose I.D. | | | | Flange Inch | A mm | B mm | E mm |
|-------------|-----------|-------|------|------|----------------|---------|---------|---------|
| | DN | Inch | Size | mm | | | | |
| KX9V6-20-20 | 31 | 1 1/4 | -20 | 31.8 | 1 1/4 | 176.8 | 85.5 | 90 |
| KX9V6-24-24 | 38 | 1 1/2 | -24 | 38.1 | 1 1/2 | 209.3 | 113 | 104 |
| KX9V6-32-32 | 51 | 2 | -32 | 50.8 | 2 | 268 | 157 | 138 |

Approved **fitting series** for hose types, depending on size: Also available in stainless steel. Details can be found in CAT 4400.1/UK

| | | | | | | | | | | | | | | |
|-----------|-----|-------|--------|--------|-------|-------|-------|-------|--------|---------|-----|-------|-------|------|
| V4 | H31 | H31TC | H31ST | R42 | R42TC | R42ST | R35 | R35TC | RS35TC | R50TC | H29 | H29TC | H29ST | FA35 |
| V6 | R35 | R35TC | RD35TC | RS35TC | R42 | R42ST | R42TC | R50TC | FA35 | CEM69TC | | | | |



XA Caterpillar® Flange Straight

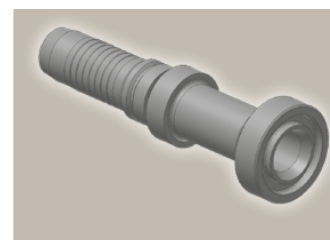
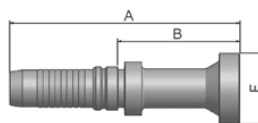

| Part Number | Hose I.D. | | | | Flange | A | B | F |
|-------------|---------------|-------|------|------|------------|-----|-----|----|
| | DN | Inch | Size | mm | | | | |
| KXAV4-12-12 | 19 | 3/4 | -12 | 19.1 | 3/4 | 132 | 71 | 41 |
| KXAV4-16-12 | 19 | 3/4 | -12 | 19.1 | 1 | 144 | 82 | 48 |
| KXAV4-16-16 | 25 | 1 | -16 | 25.4 | 1 | 155 | 82 | 48 |
| KXAV4-20-16 | 25 | 1 | -16 | 25.4 | 1 1/4 | 160 | 88 | 54 |
| KXAV6-20-20 | 31 | 1 1/4 | -20 | 31.8 | 1 1/4 | 181 | 90 | 54 |
| KXAV6-24-20 | 31 | 1 1/4 | -20 | 31.8 | 1 1/2 | 188 | 97 | 64 |
| KXAV6-24-24 | 38 | 1 1/2 | -24 | 38.1 | 1 1/2 | 207 | 111 | 64 |

XF Caterpillar® Flange 45° Elbow

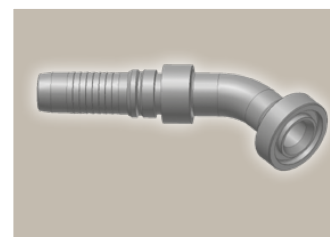
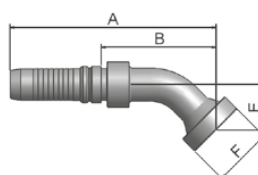

| Part Number | Hose I.D. | | | | Flange | A | B | E | F |
|-------------|---------------|-------|------|------|------------|-----|-----|----|----|
| | DN | Inch | Size | mm | | | | | |
| KXFF4-12-12 | 19 | 3/4 | -12 | 19.1 | 3/4 | 138 | 76 | 31 | 41 |
| KXFF4-16-16 | 25 | 1 | -16 | 25.4 | 1 | 164 | 91 | 36 | 48 |
| KXFF4-20-16 | 25 | 1 | -16 | 25.4 | 1 1/4 | 164 | 92 | 35 | 54 |
| KXFF6-20-20 | 31 | 1 1/4 | -20 | 31.8 | 1 1/4 | 187 | 96 | 37 | 54 |
| KXFF6-24-20 | 31 | 1 1/4 | -20 | 31.8 | 1 1/2 | 187 | 96 | 37 | 64 |
| KXFF6-24-24 | 38 | 1 1/2 | -24 | 38.1 | 1 1/2 | 216 | 120 | 39 | 64 |

V4/V6 Series

Approved **fitting series** for hose types, depending on size: Also available in stainless steel. Details can be found in CAT 4400.1/UK

| | | | | | | | | | | | | | | |
|-----------|-----|-------|--------|--------|-------|-------|-------|-------|--------|---------|-----|-------|-------|------|
| V4 | H31 | H31TC | H31ST | R42 | R42TC | R42ST | R35 | R35TC | RS35TC | R50TC | H29 | H29TC | H29ST | FA35 |
| V6 | R35 | R35TC | RD35TC | RS35TC | R42 | R42ST | R42TC | R50TC | FA35 | CEM69TC | | | | |

High Pressure
Flange

ParLock Fittings
V4/V6 Series

XG Caterpillar® Flange 60° Elbow

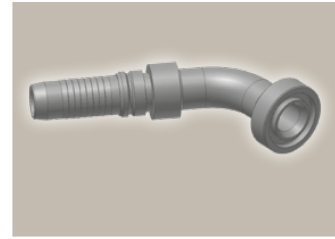
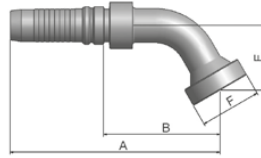

| Part Number | Hose I.D. | | | | Flange Inch | A mm | B mm | E mm | F mm |
|-------------|-----------|-------|------|------|----------------|---------|---------|---------|---------|
| | DN | Inch | Size | mm | | | | | |
| KXGV4-16-12 | 19 | 3/4 | -12 | 19.1 | 1 | 152 | 91 | 42 | 48 |
| KXGV4-16-16 | 25 | 1 | -16 | 25.4 | 1 | 182 | 109 | 50 | 48 |
| KXGV4-20-16 | 25 | 1 | -16 | 25.4 | 1 1/4 | 184 | 112 | 50 | 54 |
| KXGV6-20-20 | 31 | 1 1/4 | -20 | 31.8 | 1 1/4 | 206 | 115 | 55 | 54 |
| KXGV6-24-20 | 31 | 1 1/4 | -20 | 31.8 | 1 1/2 | 208 | 117 | 52 | 64 |
| KXGV6-24-24 | 38 | 1 1/2 | -24 | 38.1 | 1 1/2 | 266 | 170 | 52 | 64 |

XN Caterpillar® Flange 90° Elbow

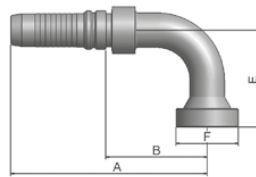

| Part Number | Hose I.D. | | | | Flange Inch | A mm | B mm | E mm | F mm |
|-------------|-----------|-------|------|------|----------------|---------|---------|---------|---------|
| | DN | Inch | Size | mm | | | | | |
| KXNV4-12-12 | 19 | 3/4 | -12 | 19.1 | 3/4 | 125 | 63 | 63 | 41 |
| KXNV4-16-12 | 19 | 3/4 | -12 | 19.1 | 1 | 125 | 63 | 62 | 48 |
| KXNV4-16-16 | 25 | 1 | -16 | 25.4 | 1 | 150 | 77 | 74 | 48 |
| KXNV4-20-16 | 25 | 1 | -16 | 25.4 | 1 1/4 | 154 | 81 | 74 | 54 |
| KXNV6-20-20 | 31 | 1 1/4 | -20 | 31.8 | 1 1/4 | 177 | 86 | 77 | 54 |
| KXNV6-24-20 | 31 | 1 1/4 | -20 | 31.8 | 1 1/2 | 177 | 86 | 77 | 64 |
| KXNV6-24-24 | 38 | 1 1/2 | -24 | 38.1 | 1 1/2 | 209 | 113 | 106 | 64 |

Approved **fitting series** for hose types, depending on size: Also available in stainless steel. Details can be found in CAT 4400.1/UK

V4 H31 H31TC H31ST R42 R42TC R42ST R35 R35TC RS35TC R50TC H29 H29TC H29ST FA35

V6 R35 R35TC RD35TC RS35TC R42 R42ST R42TC R50TC FA35 CEM69TC



Df-22

Catalogue 4400/UK

JC Female ORFS Swivel – Straight Short

ISO 12151-1 – SWSA
SAE J516 – ORFS

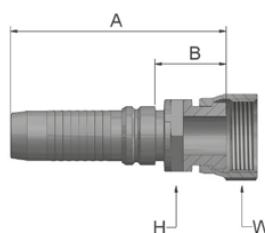

| Part Number | Hose I.D. | | | | Thread UNF | A mm | B mm | H mm | W mm |
|-------------|-----------|-------|------|------|---------------|---------|---------|---------|---------|
| | DN | Inch | Size | mm | | | | | |
| KJCV4-12-12 | 19 | 3/4 | -12 | 19.1 | 1 3/16x12 | 93 | 31.3 | 30 | 36 |
| KJCV4-16-12 | 19 | 3/4 | -12 | 19.1 | 1 7/16x12 | 93 | 31 | 36 | 41 |
| KJCV4-12-16 | 25 | 1 | -16 | 25.4 | 1 3/16x12 | 101 | 29 | 36 | 36 |
| KJCV4-16-16 | 25 | 1 | -16 | 25.4 | 1 7/16x12 | 108 | 36 | 36 | 41 |
| KJCV4-20-16 | 25 | 1 | -16 | 25.4 | 1 11/16x12 | 120 | 47 | 41 | 50 |
| KJCV4-20-20 | 31 | 1 1/4 | -20 | 31.8 | 1 11/16x12 | 127 | 39 | 46 | 50 |
| KJCV6-20-20 | 31 | 1 1/4 | -20 | 31.8 | 1 11/16x12 | 132 | 41 | 46 | 50 |
| KJCV6-24-20 | 31 | 1 1/4 | -20 | 31.8 | 2x12 | 133 | 42 | 50 | 60 |
| KJCV4-24-24 | 38 | 1 1/2 | -24 | 38.1 | 2x12 | 131 | 37.9 | 50 | 60 |
| KJCV6-24-24 | 38 | 1 1/2 | -24 | 38.1 | 2x12 | 140 | 44 | 50 | 60 |

JS ORFS Swivel Female (Long)

ISO 12151-1-SWSB
SAE J516 – ORFS

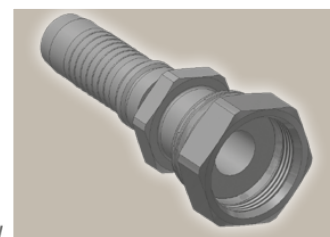
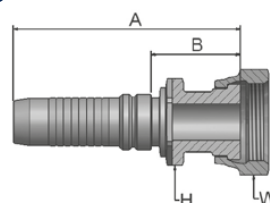

| Part Number | Hose I.D. | | | | Thread UNF | A mm | B mm | H mm | W mm |
|-------------|-----------|-------|------|------|---------------|---------|---------|---------|---------|
| | DN | Inch | Size | mm | | | | | |
| KJSV4-16-16 | 25 | 1 | -16 | 25.4 | 1 7/16x12 | 121 | 49 | 36 | 41 |
| KJSV4-20-16 | 25 | 1 | -16 | 25.4 | 1 11/16x12 | 120 | 47.7 | 41 | 50 |
| KJSV4-20-20 | 31 | 1 1/4 | -20 | 31.8 | 1 11/16x12 | 137 | 49.7 | 41 | 50 |

V4/V6 Series

Approved **fitting series** for hose types, depending on size: Also available in stainless steel. Details can be found in CAT 4400.1/UK

| | | | | | | | | | | | | | | |
|-----------|-----|-------|--------|--------|-------|-------|-------|-------|--------|---------|-----|-------|-------|------|
| V4 | H31 | H31TC | H31ST | R42 | R42TC | R42ST | R35 | R35TC | RS35TC | R50TC | H29 | H29TC | H29ST | FA35 |
| V6 | R35 | R35TC | RD35TC | RS35TC | R42 | R42ST | R42TC | R50TC | FA35 | CEM69TC | | | | |

J7 Female ORFS – Swivel 45° Elbow

ISO 12151-1 – SWE 45°
SAE J516 – ORFS 45°

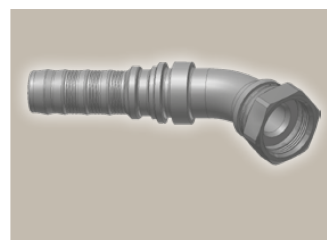
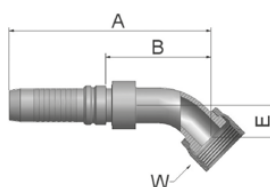

| Part Number | Hose I.D. | | | | Thread UNF | A mm | B mm | E mm | W mm |
|-------------|-----------|-------|------|------|---------------|---------|---------|---------|---------|
| | DN | Inch | Size | mm | | | | | |
| KJ7V4-12-12 | 19 | 3/4 | -12 | 19.1 | 1 3/16x12 | 128 | 66.3 | 21 | 36 |
| KJ7V4-16-12 | 19 | 3/4 | -12 | 19.1 | 1 7/16x12 | 131 | 70 | 24 | 41 |
| KJ7V4-16-16 | 25 | 1 | -16 | 25.4 | 1 7/16x12 | 152 | 79 | 24 | 41 |
| KJ7V4-20-16 | 25 | 1 | -16 | 25.4 | 1 11/16x12 | 154 | 81 | 26 | 50 |
| KJ7V4-20-20 | 31 | 1 1/4 | -20 | 31.8 | 1 11/16x12 | 189 | 101.7 | 30 | 50 |
| KJ7V6-20-20 | 31 | 1 1/4 | -20 | 31.8 | 1 11/16x12 | 179 | 87.8 | 33 | 50 |
| KJ7V6-24-20 | 31 | 1 1/4 | -20 | 31.8 | 2x12 | 190 | 99 | 40 | 60 |
| KJ7V4-24-24 | 38 | 1 1/2 | -24 | 38.1 | 2x12 | 218 | 124.9 | 40 | 60 |
| KJ7V6-24-24 | 38 | 1 1/2 | -24 | 38.1 | 2x12 | 216 | 120 | 40 | 60 |

J9 Female ORFS – Swivel 90° Elbow – Short Drop

ISO 12151-1 – SWES
SAE J516 – ORFS 90°

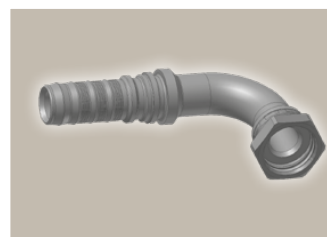
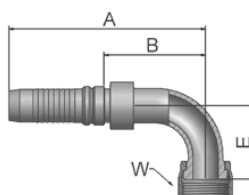

| Part Number | Hose I.D. | | | | Thread UNF | A mm | B mm | E mm | W mm |
|-------------|-----------|-------|------|------|---------------|---------|---------|---------|---------|
| | DN | Inch | Size | mm | | | | | |
| KJ9V4-12-12 | 19 | 3/4 | -12 | 19.1 | 1 3/16x12 | 125 | 63.3 | 48 | 36 |
| KJ9V4-16-12 | 19 | 3/4 | -12 | 19.1 | 1 7/16x12 | 125 | 63 | 56 | 41 |
| KJ9V4-16-16 | 25 | 1 | -16 | 25.4 | 1 7/16x12 | 150 | 77.7 | 56 | 41 |
| KJ9V4-20-16 | 25 | 1 | -16 | 25.4 | 1 11/16x12 | 150 | 77 | 64 | 50 |
| KJ9V4-20-20 | 31 | 1 1/4 | -20 | 31.8 | 1 11/16x12 | 186 | 98 | 69 | 50 |
| KJ9V6-20-20 | 31 | 1 1/4 | -20 | 31.8 | 1 11/16x12 | 177 | 86 | 79 | 50 |
| KJ9V6-24-20 | 31 | 1 1/4 | -20 | 31.8 | 2x12 | 177 | 86 | 70 | 60 |
| KJ9V4-24-24 | 38 | 1 1/2 | -24 | 38.1 | 2x12 | 210 | 116.9 | 82 | 60 |
| KJ9V6-24-24 | 38 | 1 1/2 | -24 | 38.1 | 2x12 | 202 | 106 | 87 | 60 |

Approved **fitting series** for hose types, depending on size: Also available in stainless steel. Details can be found in CAT 4400.1/UK

| | |
|-----------|-----------------------------------------------------------------------------|
| V4 | H31 H31TC H31ST R42 R42TC R42ST R35 R35TC RS35TC R50TC H29 H29TC H29ST FA35 |
| V6 | R35 R35TC RD35TC RS35TC R42 R42ST R42TC R50TC FA35 CEM69TC |



High Pressure
ORFS

ParLock Fittings
V4/V6 Series

JM

ORFS Male

ISO 12151-1-S – SAE J516

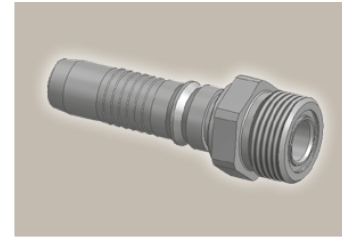
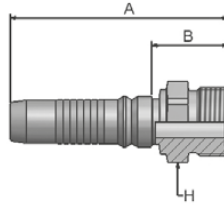

| Part Number | Hose I.D. | | | | Thread UNF | A mm | B mm | H mm |
|-------------|-----------|------|------|------|---------------|---------|---------|---------|
| | DN | Inch | Size | mm | | | | |
| KJMV4-12-12 | 19 | 3/4 | -12 | 19.1 | 1 3/16x12 | 95 | 33.3 | 32 |
| KJMV4-16-12 | 19 | 3/4 | -12 | 19.1 | 1 7/16x12 | 98.7 | 37 | 41 |

V4/V6 Series

Approved **fitting series** for hose types, depending on size: Also available in stainless steel. Details can be found in CAT 4400.1/UK

V4 H31 H31TC H31ST R42 R42TC R42ST R35 R35TC RS35TC R50TC H29 H29TC H29ST FA35

V6 R35 R35TC RD35TC RS35TC R42 R42ST R42TC R50TC FA35 CEM69TC



Df-25

Catalogue 4400/UK

Shell

Page Dg-1

V5

Dg-1

Interlock
In-/Outside Skive
R56TC Hose

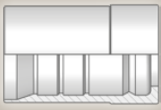

DIN – Metric

Page Dg-2 – Dg-3

C9

Dg-2

Female Metric 24° – Swivel
Heavy Series with O-Ring
Straight
ISO 12151-2-SWS-S – DKOS

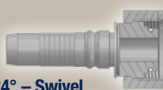

0C

Dg-2

Female Metric 24° – Swivel
Heavy Series with O-Ring
45° Elbow
ISO 12151-2 – SWE-S – DKOS 45°

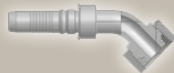

1C

Dg-3

Female Metric 24° – Swivel
Heavy Series with O-Ring
90° Elbow
ISO 12151-2-SWE-S – DKOS 90°



High Pressure
Shell

ParLock Fittings
V5 Series

V5 **Interlock
In-/Outside Skive**
R56TC Hose

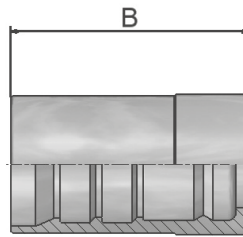

Only for use with
adjustable crimpers.

| Part Number |  Hose I.D. | | | | B mm |
|-------------|------------------------------------------------------------------------------------------------|------|------|------|---------|
| | DN | Inch | Size | mm | |
| 100V5-6 | 10 | 3/8 | -6 | 9.5 | 47 |
| 100V5-8 | 12 | 1/2 | -8 | 12.7 | 53 |

V5 Series

Approved **fitting series** for hose types:

V5 R56TC



Dg-1

Catalogue 4400/UK

High Pressure
DIN – Metric

ParLock Fittings
V5 Series

C9 Female Metric 24° – Swivel Heavy Series with O-Ring Straight

ISO 12151-2-SWS-S – DKOS

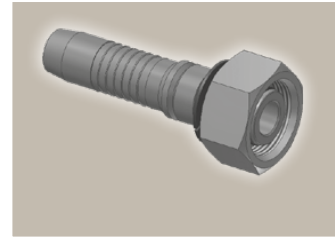
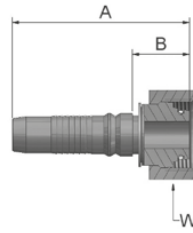

| Part Number | Hose I.D. | | | | Thread metric | Tube O.D. mm | A mm | B mm | W mm |
|-------------|-----------|------|------|------|---------------|--------------|------|------|------|
| | DN | Inch | Size | mm | | | | | |
| KC9V5-14-6 | 10 | 3/8 | -6 | 9.5 | M22x1.5 | 14 | 69 | 23 | 27 |
| KC9V5-16-8 | 12 | 1/2 | -8 | 12.7 | M24x1.5 | 16 | 79 | 26 | 30 |

Fittings with standard O-ring seals can be used for temperatures from -40 °C up to +105 °C. O-rings see section Eb. Special O-rings are available on request.

0C Female Metric 24° – Swivel Heavy Series with O-Ring 45° Elbow

ISO 12151-2 – SWE -S – DKOS 45°

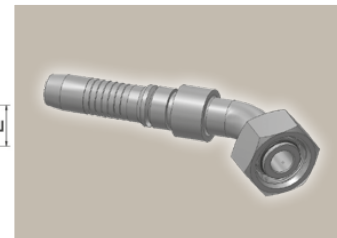
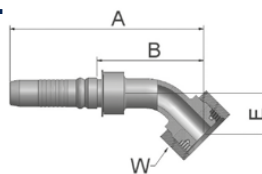

| Part Number | Hose I.D. | | | | Thread metric | Tube O.D. mm | A mm | B mm | E mm | W mm |
|-------------|-----------|------|------|------|---------------|--------------|------|------|------|------|
| | DN | Inch | Size | mm | | | | | | |
| K0CV5-14-6 | 10 | 3/8 | -6 | 9.5 | M22x1.5 | 14 | 99 | 50 | 20 | 27 |
| K0CV5-16-8 | 12 | 1/2 | -8 | 12.7 | M24x1.5 | 16 | 112 | 60 | 24 | 30 |

Fittings with standard O-ring seals can be used for temperatures from -40 °C up to +105 °C. O-rings see section Eb. Special O-rings are available on request.

Approved **fitting series** for hose types:

V5 R56TC



Dg-2

Catalogue 4400/UK

1C Female Metric 24° – Swivel Heavy Series with O-Ring 90° Elbow

ISO 12151-2-SWE-S – DKOS 90°

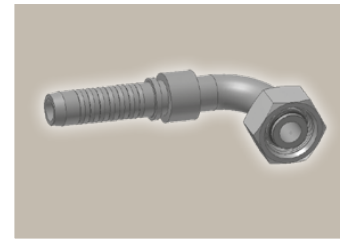
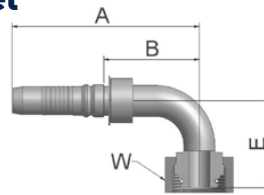

| Part Number | Hose I.D. | | | | Thread metric | Tube O.D. mm | A mm | B mm | E mm | W mm |
|-------------|-----------|------|------|------|---------------|--------------|------|------|------|------|
| | DN | Inch | Size | mm | | | | | | |
| K1CV5-14-6 | 10 | 3/8 | -6 | 9.5 | M22x1.5 | 14 | 88 | 39 | 37 | 27 |
| K1CV5-16-8 | 12 | 1/2 | -8 | 12.7 | M24x1.5 | 16 | 101 | 48 | 45 | 30 |

Fittings with standard O-ring seals can be used for temperatures from -40 °C up to +105 °C. O-rings see section Eb. Special O-rings are available on request.

V5 Series

Approved **fitting series** for hose types:



Shell

Page Dh-1

100WB

Dh-1

Interlock
In-/Outside Skive
BPK Hose

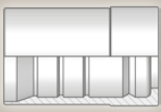

DIN – Metric

Page Dh-2

C9

Dh-2

Female Metric 24° – Swivel
Heavy Series with O-Ring
Straight
ISO 12151-2-SWS-S – DKOS



BSP

Page Dh-3

92

Dh-3

Female BSP Parallel Pipe
Swivel – Straight (60° Cone)
BS5200-A – DKR

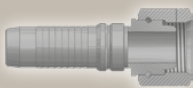

SAE

Page Dh-4

01

Dh-4

Male NPTF Pipe
Rigid – Straight
SAE J476A / J516 – AGN

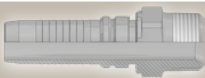

High Pressure
Shell

ParLock Fittings
WB Series

100WB Interlock In-/Outside Skive

BPK Hose

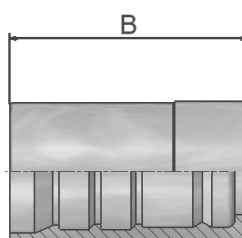

Only for use with
adjustable crimpers.

| Part Number |  Hose I.D. | | | | B mm |
|-------------|------------------------------------------------------------------------------------------------|------|------|------|---------|
| | DN | Inch | Size | mm | |
| 100WB-6 | 10 | 3/8 | -6 | 9.5 | 47.0 |
| 100WB-8 | 12 | 1/2 | -8 | 12.7 | 52.5 |
| 100WB-12 | 19 | 3/4 | -12 | 19.1 | 61.0 |
| 100WB-16 | 25 | 1 | -16 | 25.4 | 74.5 |

WB Series

Approved **fitting series** for hose types:



Dh-1

Catalogue 4400/UK

High Pressure
DIN – Metric

ParLock Fittings
WB Series

C9 Female Metric 24° – Swivel Heavy Series with O-Ring Straight

ISO 12151-2-SWS-S – DKOS

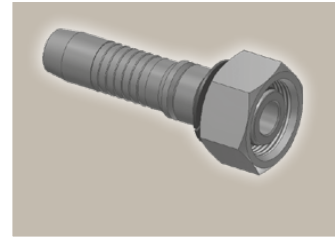
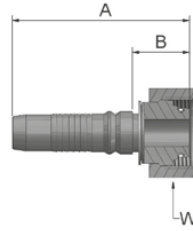

| Part Number | Hose I.D. | | | | Thread metric | Tube O.D. mm | A mm | B mm | W mm |
|-------------|-----------|------|------|------|---------------|--------------|------|------|------|
| | DN | Inch | Size | mm | | | | | |
| KC9WB-14-6 | 10 | 3/8 | -6 | 9.5 | M22x1.5 | 14 | 72 | 23 | 27 |
| KC9WB-16-8 | 12 | 1/2 | -8 | 12.7 | M24x1.5 | 16 | 85 | 32 | 30 |
| KC9WB-25-12 | 19 | 3/4 | -12 | 19.1 | M36x2 | 25 | 95 | 34 | 46 |
| KC9WB-30-16 | 25 | 1 | -16 | 25.4 | M42x2 | 30 | 108 | 36 | 50 |

Fittings with standard O-ring seals can be used for temperatures from -40 °C up to +105 °C.
O-rings see section Eb. Special O-rings are available on request.

Approved **fitting series** for hose types:







Dh-2

Catalogue 4400/UK

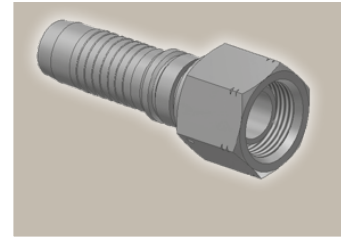
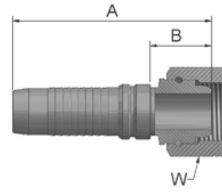
92 Female BSP Parallel Pipe Swivel – Straight (60° Cone)

BS5200-A – DKR



| Part Number |  Hose I.D. | | | |  Thread BSP | A mm | B mm |  W mm |
|-------------|------------------------------------------------------------------------------------------------|------|------|------|----------------------------------------------------------------------------------------------------|---------|---------|------------------------------------------------------------------------------------------------|
| | DN | Inch | Size | mm | | | | |
| K92WB-6-6 | 10 | 3/8 | -6 | 9.5 | 3/8x19 | 72 | 23 | 22 |
| K92WB-8-8 | 12 | 1/2 | -8 | 12.7 | 1/2x14 | 79 | 26 | 27 |

Approved **fitting series** for hose types:



01

**Male NPTF Pipe
Rigid – Straight**

SAE J476A / J516 – AGN

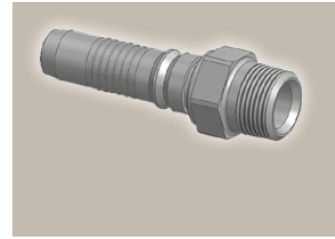
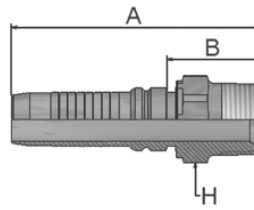

| Part Number | Hose I.D. | | | | Thread NPTF | A mm | B mm | H mm |
|-------------|---------------|------|------|------|--------------------|---------|---------|-------------|
| | DN | Inch | Size | mm | | | | |
| K01WB-6-6 | 10 | 3/8 | -6 | 9.5 | 3/8-18 | 77 | 28 | 19 |
| K01WB-8-8 | 12 | 1/2 | -8 | 12.7 | 1/2-14 | 90 | 37 | 22 |
| K01WB-12-12 | 19 | 3/4 | -12 | 19.1 | 3/4-14 | 98 | 36 | 30 |
| K01WB-16-16 | 25 | 1 | -16 | 25.4 | 1-11 1/2 | 114 | 41 | 36 |

Approved **fitting series** for hose types:





Hydraulic Hoses, Fittings and Equipment

Machines, Tooling, Accessories



ENGINEERING YOUR SUCCESS.

Hydraulic Hose Assembly Workshop Equipment

– meeting the demands of professional
hose assembly manufacture

Hose assemblies must be manufactured in conformity with all the relevant EN/ISO standards and with the requirements of various work safety and trade associations. Polymer Hose Division Europe has selected and developed a complete range of machines and tooling to ensure effective and safe production of hose assemblies. This can be achieved only when equipment designed for the purpose is used.

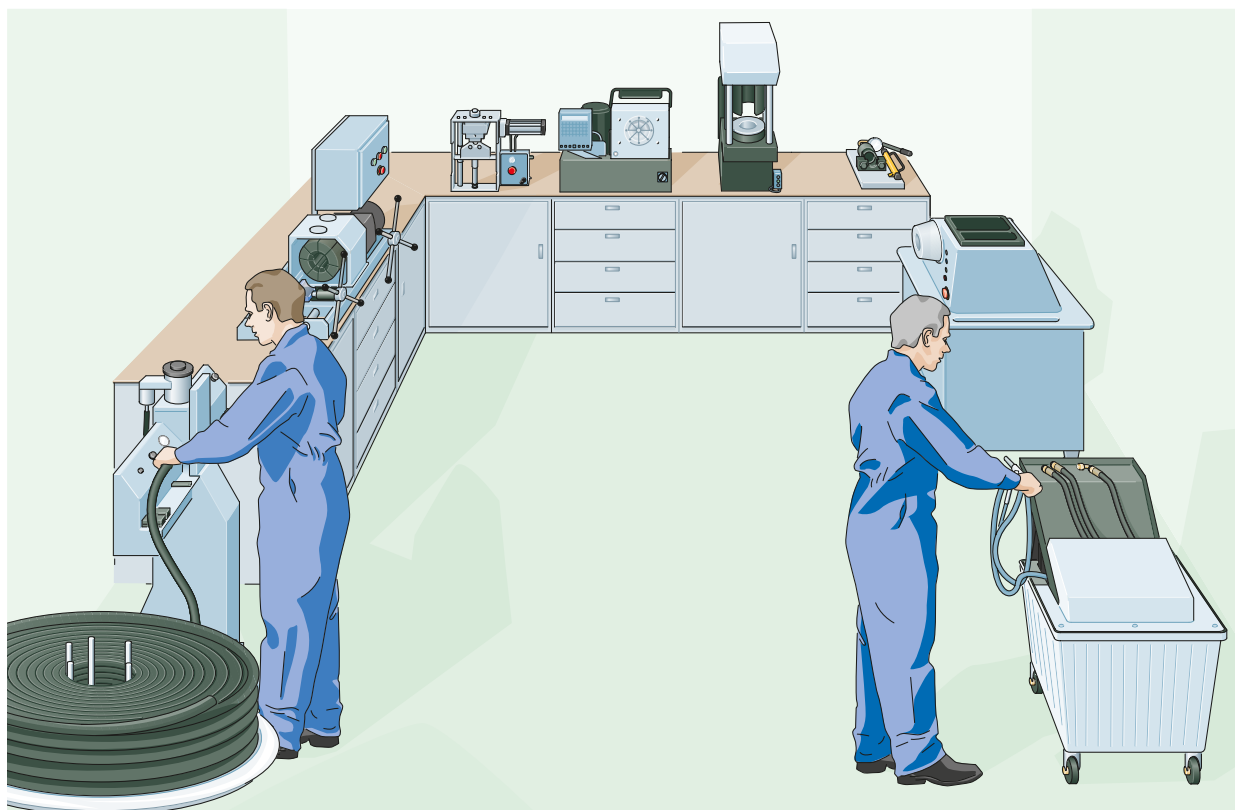

**The programme includes the right tools for
ready-to-install Parkrimp No-Skive
and ParLock hose assemblies:**

- Cutting hoses
- Crimping hoses
- Marking hose assemblies
- Cleaning hose assemblies
- Testing hose assemblies



TH 7-12
7-stage hose reel



85CE-061L + 85CE-1PE
KarryKrimp 2 Bench Mount



TH3E-EM6-M
Hose Cutting Machine



TH 5-3
Hose Assembly Test Bench



TH 4-4 U
Hand Marking Tools



TH 6-6
Cleaning System



TH8E-535-CM
Adjustable Crimper

**It's so easy to crimp
your own hose
assemblies**

Please visit us at
www.easy-crimping.com



Parkrimp® *No-Skive*

The system for fast and leak-free assemblies

Hose fittings have an impact on the overall efficiency and safety of a hydraulic system. The No-Skive concept was launched by Parker Hannifin some 30 years ago but continuous development and the use of modern materials and production techniques have resulted in a state-of-the-art hose to fitting connection. Much easier handling and a high level of safety are available with No-Skive crimp fittings. Parker offers one piece No-Skive fittings as part of a package consisting of quality hose, No-Skive fittings, hose crimpers and tooling.



Parkrimp *No-Skive* one-piece fittings



Parkrimp® *No-Skive*

- No skiving tool needed
- No need to remove the cover
- Crimps one-piece fittings
- Parkalign positions the fittings in the dies perfectly every time
- Quick and easy: no gauges to set on the machine
- Portable machines for field repair
- Meets EN safety regulations

Modular Design = Portable + Bench Mount Parkrimp crimpers for *No-Skive* one-piece fittings

The modular design enables the customer to choose between the portability that Parker KarryKrimp crimpers have always offered, and the option to make these same crimpers bench mount units. The modular design gives users the flexibility of a portable crimper with the advantage of increased productivity when connected to the Bench Power Unit 85CE-1PE.



KarryKrimp® 1

KarryKrimp® 1
Bench Mount

KarryKrimp® 2

KarryKrimp® 2
Bench Mount

ParLock Hose and Fittings

The high-performance skiving system

Certain customers and applications stipulate the usage of multispiral hose assemblies with external/internal skive-type fittings. With the ParLock hose and fitting range, Parker meets this demanding market requirement. Parker adjustable crimpers for two-piece fittings ensure precise, leak-free and tear-proof assembly of hose and fitting.

- High flex-impulse applications
- High vibration applications
- The ParLock design is approved by the German Accident Prevention & Insurance Association (Berufsgenossenschaft) conforming to EN 201 (approved for injection-moulding machine applications)

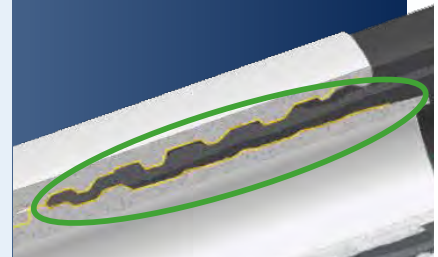

ParLock two-piece skive fittings



TH2-13-3PH
Hose skiving machine

Adjustable crimpers for two-piece ParLock fittings



TH8E-530



TH 8E-380-CM



TH 8E-480-CM

ParLock System

- A full range of multispiral hoses to ISO 3862 (4SP to R15)
- Field-tested, proven reliability
- Hose and fitting combinations giving performance that exceeds ISO/EN requirements
- Approved hose and fitting compatibility "one manufacturer, one source"

Hose Whip Restraint

Safety Restraining System for Pressure Hoses

- Prevents whipping of a pressurized hose in the event of the hose separating from its fitting
- The system consists of two parts – a hose collar and a cable assembly

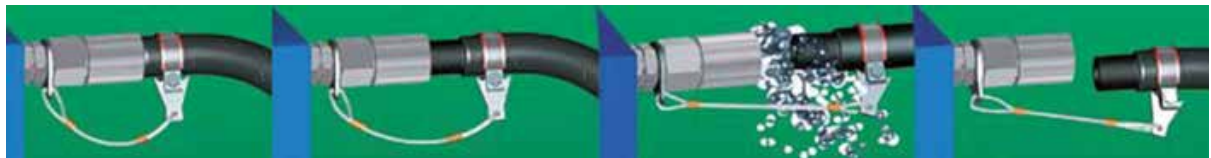

Parker's Hose Whip Restraint System is designed to prevent whipping of a pressurized hose in the event of the hose separating from its fitting. The Hose Whip Restraint System provides an additional level of safety and helps prevent damage to nearby equipment or injury to operators near the failed hose by limiting the whip or travel of the pressurized hose after it breaks free from its hose fitting. Serious damage or injury can occur from whipping hoses, especially at higher pressures.

The system consists of two parts – a hose collar and a cable assembly. The hose collar (WRCxx) is selected based on the outside diameter of the hose, and the cable assembly is selected based on the type of hose connection. Two types of cable assemblies are available – one for flange-type connections (WRFxxx), and the other for port adapters (WRAxxx).

The Hose Whip Restraint is not to be used in place of proper hose crimping procedures. Exceeding the maximum operating pressure of the hose jeopardizes the proper operation of the Hose Whip Restraint System.

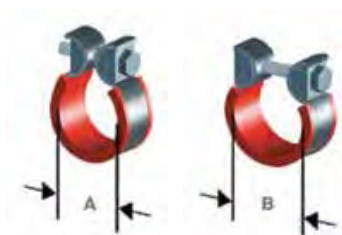

Hose collars
for Hose Whip Restraint System



Cable Assemblies
for hoses attached with port adapters



Cable Assemblies
for hoses using flange-style
connections
ISO 6162-1 (35.0 MPa/5000 psi) and
ISO 6162-2 (42.0 MPa/ 6000 psi)

For more information about
hose whip restraint please
refer to page *Eb-19*.

Machines, Tooling, Accessories

Machines

| | |
|--------------------------------------------|---------------|
| Parkrimp® Crimping Presses | Ea-1 – Ea-4 |
| Accessories for Parkrimp® Crimping Presses | Ea-5 |
| Parkrimp® Die Sets / Die Storage Racks | Ea-6 |
| Hose Cutting Machines | Ea-7 – Ea-12 |
| Marking Machines | Ea-13 – Ea-14 |
| Cleaning Systems | Ea-15 – Ea-18 |
| Hose Assembly Test Bench | Ea-19 |
| Hose Reels | Ea-20 – Ea-21 |
| Adjustable Crimping Presses | Ea-22 – Ea-26 |
| Hose Skiving Machines | Ea-27 – Ea-29 |
| Skiving Tools for Hose Skiving Machines | Ea-30 |
| Clean Seal Capsules | Ea-31 |
| Clean Seal Protection – Heat Shrink | Ea-32 |
| Assembly and Hose Fitting Insertion Device | Ea-33 |

Accessories

| | |
|---------------------------------------------------|---------------|
| Flange Half | Eb-1 |
| Bolts for Flange Halves ISO 6162-1 and ISO 6162-2 | Eb-2 – Eb-3 |
| Full Flange System | Eb-4 |
| Bolts for Full Flange System | Eb-5 |
| Banjo Bolt | Eb-6 |
| O-Rings | Eb-7 – Eb-8 |
| Worm Drive Hose Clamps | Eb-9 – Eb-10 |
| Hose Protection | Eb-11 – Eb-21 |
| Hose Whip Restraint | Eb-22 |
| Containment Grips | Eb-23 |
| Thread Identification Kit | Eb-23 |
| Parker „Hoze-Oil“ | Eb-24 |
| OilOn | Eb-24 |
| Push-Lok® Assembly Oil | Eb-24 |

Assembly Instructions

| | |
|-------------------------------|------|
| KarryKrimp® 1 / KarryKrimp® 2 | Ec-1 |
| Parkrimp® 2 | Ec-2 |

Your Crimp Source online

Ed-1

Parker Hannifin assumes no liability for typographical errors or other errors



KarryKrimp® 1

Modular portable crimper for braided hoses

- Crimps
 - 1 and 2 steel wire or textile braided hoses size -4 up to size -20
- Available in modular design with all Parkrimp system advantages
- The same unit offers portability and bench mountability
- Easily portable for outside work
- Used for service with hand pump or airhydraulic and electrical pump
- Portable, compact rugged design
- Pivoting pusher design for easy die change out
- Increased height enables longer bent tube fittings to be crimped

Primary Applications

Small workshops, repair shops, mobile service vehicles.



Fitting Series

26, 43, 46, 48

Restrictions

Not suitable for multispiral hoses, 2-piece fittings, stainless steel fittings and serial production of hose assemblies in size -12 and above.

Not suitable for all fitting geometries/dimensions. Please consult Parker for further information.

Technical / Order Data

| | | |
|--------------|-------------|--------------------------|
| KarryKrimp 1 | Dimensions | H 760 x W 335 x D 330 mm |
| | Weight | 28 kg |
| | Part Number | 82CE-061L |

Included standard equipment

| | | | |
|----------------|-------------|-------------|---------|
| Crimp head | Part Number | 82CE-CHD | |
| Stand assembly | Part Number | 85C-STD | |
| Hose assembly | Part Number | 85CE-00L | |
| Die rings | silver | Part Number | 82C-R01 |
| | black | Part Number | 82C-R02 |

Accessories see page **Ea-5**

KarryKrimp® 2

Modular portable crimper
for braided and multispiral hoses

- Crimps
 - 1 and 2 steel wire or textile braided hoses up to size -20
 - 3 steel wire braided hoses up to size -16
 - 4 layer multispiral hoses up to size -16
 - Compact spiral hoses up to size -12 797 (STD-TC-ST)
- Available in modular design with all Parkrimp system advantages
- The same unit offers portability and bench mountability
- Easily portable for outside work
- Portable, compact rugged design
- Pivoting pusher design for easy die change out

Primary Applications

Small workshops, repair shops, mobile service vehicles.
Crimps both steel and stainless steel fittings.



Fitting Series

26, 43, 46, 48, 70, 73, 77

Restrictions

Not suitable for 2-piece fittings.
Not suitable for all fitting geometries/dimensions.
Please consult Parker for further information.

Technical / Order Data

| | | |
|---------------------|--------------------|--------------------------|
| KarryKrimp 2 | Dimensions | H 805 x W 340 x D 350 mm |
| | Weight | 46 kg |
| | Part Number | 85CE-061L |

Included standard equipment

| | | |
|-----------------------|--------------------|----------------------------|
| <i>Crimp head</i> | Part Number | 85CE-CHD |
| <i>Stand assembly</i> | Part Number | 85C-STD |
| <i>Hose assembly</i> | Part Number | 85CE-00L |
| <i>Die rings</i> | silver | Part Number 85C-R01 |
| | black | Part Number 85C-R02 |

Accessories see page **Ea-5**

KarryKrimp Bench Mount

Modular crimpers with Bench Power Unit for workshops

- In addition to the portable versions, the sole crimping units can be used with the Bench Power Unit for workshop versions
- Faster cycle times for increased productivity
- Increased height for longer elbows or bent tube fittings
- The crimpers and the Bench Power Unit are supplied separately



Modular Design = Portable + Bench Mount

The modular design enables the customer to choose between the portability that Parker KarryKrimp crimpers have always offered, and the option to make these same crimpers bench mount units.

The modular design gives users the flexibility of a portable crimper with the advantage of increased productivity when connected to the Bench Power Unit 85CE-1PE.



Technical / Order Data

Bench Power Unit 85CE-1PE



| | |
|---------------------|--------------------------|
| Working pressure | 70 MPa |
| Dimensions | L 425 x W 525 x H 460 mm |
| Weight | 62 kg |
| Usable oil capacity | 8000 ccm |
| Electrical power | 230 V / 50/60 Hz / 10 A |
| Part Number | 85CE-1PE |

Parkrimp® 2

Bench-mounted crimper for all Parkrimp *No-Sliver* hose types from size -4 up to size -32, including 4 and 6 layer multispiral hoses

- Crimps
 - 1 and 2 steel wire or textile braided hoses up to size -32
 - 3 steel wire braided compact up to size -16
 - 4 and 6 layer multispiral hoses up to size -32
 - Compact Spiral hoses up to size -24 (Size -32 not recommended)
 - Stainless steel fitting series 77 up to size -24
- Used for service with 400 V hydraulic power unit

Primary Applications

Workshops and repair shops (for small series).
Crimps both steel and stainless steel fittings.



Fitting Series

26, 43, 46, 48, 70, 73, 77

Restrictions

Not suitable for 2-piece fittings.
For steel and stainless steel fittings series 77 size -32 only partially suitable.
Not suitable for all fitting geometries/dimensions.
Please consult Parker for further information.

Technical / Order Data

| | | |
|------------------------------------------------------------------------------------------------|--------------------|---------------------------------------------------|
| Parkrimp 2 with power unit, bench-mounted, but without die sets, connector plug and oil | Electrical power | 400 V / 4.4 kW / 8.9 A / 50 Hz |
| | Dimensions | H 1170 x W 530 x D 985 mm |
| | Weight | without packaging 370 kg with packaging 430 kg |
| | Part Number | 83CE-083U |

Included standard equipment

| | | |
|---------------------|--------------------|-----------------|
| <i>Adaptor bowl</i> | Part Number | 83C-0CB |
| <i>Die ring</i> | Part Number | 83C-R02 |
| <i>Die plate</i> | Part Number | 83C-R02H |

Accessories for KarryKrimp® 1 and KarryKrimp® 2

For use with Karrykrimp 1 crimping press

Hand pump
82C-2HP



| | |
|---------------------|--------------------------|
| Working pressure | max. 70 MPa |
| Dimensions | L 530 x W 121 x H 178 mm |
| Weight | 4.1 kg |
| Usable oil capacity | 900 ccm |
| Lever force | 42 kg |
| Part Number | 82C-2HP |

For use with KarryKrimp 1 and KarryKrimp 2 crimping presses

Hand pump
85CE-0HP



| | |
|---------------------|--------------------------|
| Working pressure | max. 70 MPa |
| Dimensions | L 580 x W 150 x H 195 mm |
| Weight | 10.7 kg |
| Usable oil capacity | 2200 ccm |
| Lever force | 35 kg |
| Part Number | 85CE-0HP |

Turbo air pump
85C-0AP



| | |
|---------------------|--------------------------|
| Working pressure | 70 MPa |
| Dimensions | L 350 x W 170 x H 210 mm |
| Weight | 8.2 kg |
| Usable oil capacity | 2080 ccm |
| Connection | air 1/4-18 NPTF thread |
| Part Number | 85C-0AP |

Power pump
82CE-0EP



| | |
|---------------------|----------------------------|
| Working pressure | 70 MPa with 3/2 hand valve |
| Dimensions | L 244 x W 244 x H 362 mm |
| Weight | 10.0 kg |
| Usable oil capacity | 1900 ccm |
| Connection | 230 V / 50/60 Hz / 10 A |
| Part Number | 82CE-0EP |

Air Hydraulic pump
85CE-XAM

Optional: Manual lever
Part Number
85CE-XA-LK1



| | |
|---------------------|----------------------------------------------------------------|
| Working pressure | 70 MPa |
| Dimensions | L 351 x W 260 x H 152 mm |
| Weight | 8.8 kg |
| Usable oil capacity | 1000 ccm |
| Connection | air: 1/4-18 NPTF female oil: 3/8-18 NPTF female; 90° swivel |
| Part Number | 85CE-XAM |

Bench Power Unit
85CE-1PE



| | |
|---------------------|--------------------------|
| Working pressure | 70 MPa |
| Dimensions | L 425 x W 525 x H 460 mm |
| Weight | 62 kg |
| Usable oil capacity | 8000 ccm |
| Electrical power | 230 V / 50/60 Hz / 10 A |
| Part Number | 85CE-1PE |

Hose Assemblies 82CE-00L (DN06)
resp. 85CE-00L (DN10)
Hose assembly to connect
pump to the press



| | |
|--------------------|--------------------------------|
| Working pressure | max. 70 MPa |
| Length | 1830 mm |
| Port size | 3/8-18 NPT male, coupling 3/8" |
| Part Number | 82CE-00L resp. 85CE-00L |

Parkrimp® Die Sets

Parker`s Colour-Coded Die Sets

- Chain link keeps segments together
- No loose parts to mismatch or misplace
- The crimp die provides 360-degree gripping power for greater impulse life



| Hose I.D. size | DN | Die sets | Part Number | | | | | | |
|----------------|----|----------|-------------|----------------------|-----------|----------------------|---------------------|--------------------|-----------|
| | | | 26 series | 43 series | 46 series | 48 series | 70 series | 73 series | 77 series |
| -4 | 6 | red | 80C-E04 | 80C-A04 | 80C-B04 | 80C-C04 | | | |
| -5 | 8 | violett | 80C-E05 | 80C-A05 | 80C-B05 | 80C-C05 | | | |
| -6 | 10 | yellow | 80C-E06 | 80C-A06 | 80C-B06 | 80C-C06 | 83C-D06 | | |
| -8 | 12 | blue | 80C-E08 | 80C-A08 | 80C-B08 | 80C-C08 | 83C-D08 | | 80C-CS08 |
| -10 | 16 | orange | 80C-E10 | 80C-A10 | 80C-B10 | 80C-C10 | 83C-D10 | | 80C-CS10 |
| -12 | 20 | green | 80C-E12 | 80C-A12 | 80C-B12 | 80C-C12 | 83C-D12 | 83C-L12 or 80C-L12 | 80C-CS12 |
| -16 | 25 | black | 80C-E16 | 80C-A16 or 83C-A16H | 80C-B16 | 80C-C16 | 83C-D16 or 83C-D16H | 83C-L16 or 80C-L16 | 83C-CS16 |
| -20 | 32 | white | 83C-E20 | 80C-A20 or 83C-A20H* | 80C-B20 | 80C-C20 or 83C-C20H* | | 83C-L20 | 83C-CS20 |
| -24 | 40 | red | 83C-E24 | 83C-A24 | | 83C-C24 | | 83C-L24 | 83C-CS24 |
| -32 | 50 | green | 83C-E32 | 83C-A32 | | 83C-C32 | | 83C-L32 | 83C-CS32 |

Note: *Please consult the pages **Ec** for assembly instructions. Die sets with the "H" suffix are used for jump sizes and certain metric fittings to permit insertion and removal of fittings. Die sets 80C-XX 8 segments are chained together. Die sets 83C-XX consist of two chained halves. Exceptions 83C-D06, -D08, -D10, -D12, -D16

Die Storage Racks

- Modular die rack designed to hold small and large Parkrimp dies
- Can be bolted together to a work bench horizontally or vertically

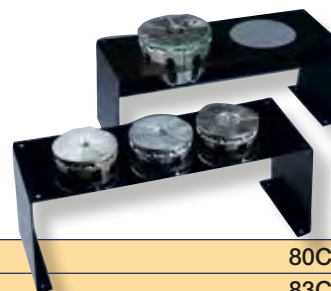

| | | |
|-------------------------------------|-------------|---------|
| Storage of three sets of small dies | Part Number | 80C-0DR |
| Storage of two sets of large dies | Part Number | 83C-0DR |

EM 10.P

Hose Cutting Machine

- Cuts
 - 1 steel wire or textile braided hoses up to size -16
 - 2 steel wire braided hoses up to size -12
- Can be used on a workbench or in a vice bench
- Cutting blade covered during use
- Equipped with an electrical safety switch



Primary Applications

Repair shops or mobile service vehicles, preferably in combination with KarryKrimp 1

Restrictions

Not suitable for multispiral hoses or large bore industrial hoses.

Technical / Order Data

Hose Cutting Machine EM 10.P

with cutting blade, smooth TM 160 x 2,5 x 20

Cutting blade, smooth

| | |
|-----------------------|------------------------------|
| Electric motor | circular saw motor 230 V |
| Electric power | 50/60 Hz / 1200 W / 6100 rpm |
| Electrical insulation | according VDE KI.II 0740 |
| Radioshielding | according VDE 0875 |
| Cutting blade | 160 x 2.5 x 20 mm (HSS) |
| Dimensions | L 360 x W 340 x H 310 mm |
| Weight | 8 kg |
| Part Number | EM 10.P |
| Part Number | TM 160 x 2,5 x 20 |

TH 3-2-12VDC

Hose Cutting Machine

- Cuts
 - 1 and 2 steel wire or textile braided hoses up to size -20
 - 4 steel wire multispiral hoses up to size -16
- For mobile service vehicles with 12 V connection

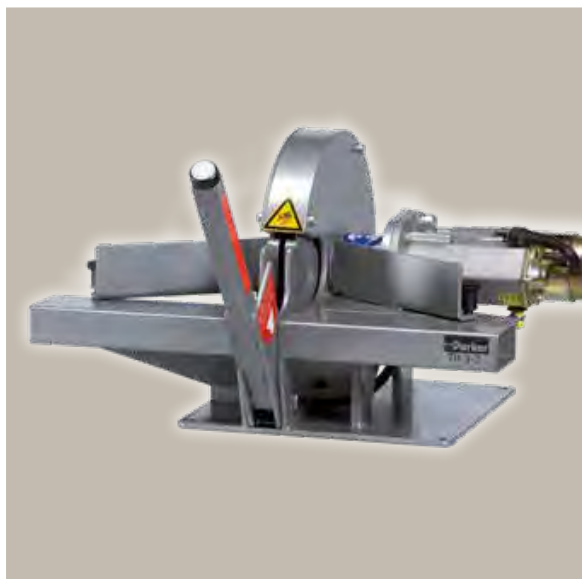

Primary Applications

Mobile service vehicles

Restrictions

Not suitable for large bore hoses.

Technical / Order Data

Hose Cutting Machine TH 3-2-12VDC
with cutting blade, serrated

| | |
|----------------|--------------------------|
| Electric motor | 12 V / 2.0 kW |
| Cutting blade | 250 x 2 x 40 mm |
| Dimensions | W 567 x D 470 x H 365 mm |
| Weight | 30 kg |

Cutting blade, serrated 250 x 2 x 40 mm

| | |
|--------------------|--------------------|
| Part Number | TH3-2-12VDC |
| Part Number | TM250x2x40Z |

*Electric motor 24 V / 3.2 kW available on request

TH 3E-EM3

Hose Cutting Machine

- Cuts
 - 1 and 2 steel wire or textile braided hoses up to size -20
 - 4 steel wire multispiral hoses up to size -20
 - Industrial hoses up to size -32
- According to the CE safety standards the blade stops within 10 seconds after switching off the brake motor
- Faster and safer cut using less energy, cutting motor with a larger shaft oversize bearing to gurantee less vibration created by radial forces
- Cutting blades approved on considered material



Primary Applications

Repair shops or mobile service vehicles

Restrictions

Not suitable for large bore industrial hoses.

Technical / Order Data

Hose Cutting Machine TH 3E-EM3
with cutting blade, serrated TMG275x3x30

Cutting blade, serrated 275 x 3 x 30 mm

| | |
|--------------------|--------------------------|
| Electrical power | 400V/ 3kW / 50Hz |
| Cutting blade | 275 x 3 x 30 mm |
| Dimensions | W 540 x D 440 x H 300 mm |
| Weight | 50 kg |
| Part Number | TH 3E-EM3 |
| Part Number | TMG275x3x30 |

TH 3E-EM6-M

TH3E-EM6-P

Hose Cutting Machines

- Cuts
 - 1 and 2 steel wire or textile braided hoses up to size -32
 - Compact Spiral hoses up to size -20
 - 6 steel wire multispiral hoses up to size -32
- According to the CE safety standards the blade stops within 10 seconds after switching off the brake motor
- Faster and safer cut using less energy, cutting motor with a larger shaft oversize bearing to guarantee less vibration created by radial forces
- Cutting blades approved on considered material

Primary Applications

Service in hose workshops and for small series production

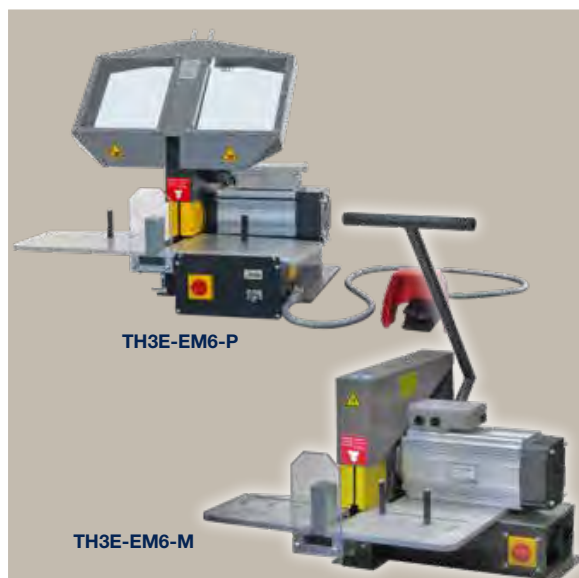

Restrictions

Cutting 6 layer multispiral hoses will reduce the service life of the blade.

Technical / Order Data

| | | |
|-------------------------------------------------------------------------------------------------------------|--------------------|--------------------------|
| Hose Cutting Machine TH 3E-EM6-M with cutting blade, serrated TMG350x3x30 | Electrical power | 400 V / 4.6 kW / 50 Hz |
| | Exhaust system Ø | 60 mm |
| | Cutting blade | 350 x 3 x 30 mm |
| | Dimensions | L 745 x W 690 x H 430 mm |
| | Weight | 75 kg |
| | Part Number | TH3E-EM6-M |
| Cutting blade, serrated 350 x 3 x 30 mm | Part Number | TMG350x3x30 |
| Hose Cutting Machine TH 3E-EM6-P with pneumatic feed with cutting blade, serrated TMG 350x3x30 | Electrical power | 400 V / 4,6 kW / 50 Hz |
| | Exhaust system Ø | 60 mm |
| | Cutting blade | 350 x 3 x 30 mm |
| | Dimensions | L 820 x B 785 x H 755 mm |
| | Weight | 110 kg |
| | Part Number | TH3E-EM6-P |
| Cutting blade, serrated 350 x 3 x 30 mm | Part Number | TMG350x3x30 |

TH 3E-115

Hose Cutting Machine

- Cuts
 - all industrial hose types up to 75 mm O.D.
 - 1, 2 and 3 steel wire or textile braided hoses up to size -40
 - 4/6 steel wire multispiral hoses up to size -32
- According to the CE safety standards the blade stops within 10 seconds after switching off the brake motor
- Faster and safer cut using less energy, cutting motor with a larger shaft oversize bearing to gurantee less vibration created by radial forces
- Cutting blades approved on considered material
- Easiest cutting of big dimensioned hoses with more energy efficient machines



Primary Applications

Service and series production at workshops.

Technical / Order Data

| | | |
|---------------------------------------------------------------------------------|--------------------|-------------------------------|
| Hose Cutting Machine TH 3E-115 with cutting blade, coated TMC520x4x40 | Electrical power | 400 V / 7.5 kW / 25 A / 50 Hz |
| | Exhaust system Ø | 100 mm |
| | Cutting blade | 520 x 4 x 40 mm |
| | Dimensions | L 1210 x W 650 x H 1650 mm |
| | Weight | 245 kg |
| | Part Number | TH3E-115 |
| Cutting blade, coated 520 x 4 x 40 mm | Part Number | TMC520x4x40 |

TH 3E-110

Hose Cutting Machine

- Cuts
 - 1 and 2 steel wire or textile braided hoses up to size -48
 - 4 steel wire multispiral hoses up to size -48
 - 6 steel wire multispiral hoses up to size -48
 - Industrial hoses up to size -64
- According to the CE safety standards the blade stops within 10 seconds after switching off the brake motor
- Faster and safer cut using less energy, cutting motor with a larger shaft oversize bearing to guarantee less vibration created by radial forces
- Cutting blades approved on considered material
- Easiest cutting of big dimensioned hoses with more energy efficient machines



Primary Applications

Service and series production at workshops

Technical / Order Data

| | | |
|---------------------------------------------------------------------------------|--------------------|-------------------------------|
| Hose Cutting Machine TH 3E-110 with cutting blade, coated TMC520x4x40 | Electrical power | 400 V / 7.5 kW / 25 A / 50 Hz |
| | Exhaust system Ø | 100 mm |
| | Cutting blade | 520 x 4 x 40 |
| | Dimensions | W 800 x D 780 x H 1700 mm |
| | Weight | 280 kg |
| | Part Number | TH3E-110 |
| Cutting blade, coated 520 x 4 x 40 mm | Part Number | TMC520x4x40 |

TH 4-7, TH 4-8

Marking Machines

- Manually or pneumatically driven
- Suitable for marking all 1- and 2-piece fittings series up to size -32

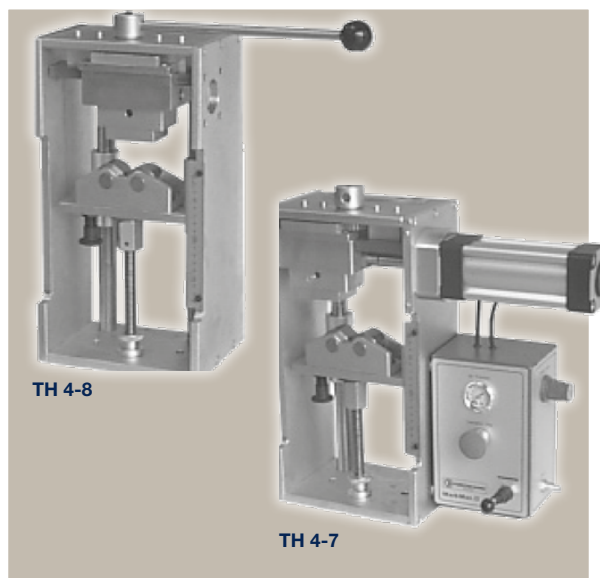

Primary Applications

Smaller workshops and mobile service vehicles

Technical / Order Data

| | | |
|----------------------------------------------------------------------------------------|--------------------|--------------------------|
| Marking Machine TH 4-8 manual excl. QC-adapter, type case and type holder | Colour | zinc plated |
| | Dimensions | L 500 x W 200 x H 500 mm |
| | Weight | 28 kg |
| | Part Number | TH4-8 |
| Marking Machine TH 4-7 pneumatic excl. QC-adapter, type case and type holder | Colour | zinc plated |
| | Air pressure | min. 0.6 MPa |
| | Dimensions | L 500 x W 380 x H 500 mm |
| | Weight | 35 kg |
| Type case 3 mm | Part Number | TH4-9 |
| Type print holder 2 lines | Part Number | TH4-9-1 |
| QC-adapter for type print holder | Part Number | TH4-10 |



QC-adapter



Type case

Type case TH 4-9 content

AAABBCCDDEEEFFGGHHIIJJKK
 LLLMMNNNOOOPPQRRRSSSTT
 UUUUVVWXYZ//...,1112222333344
 445556667778889990000 and 20 pcs of blanks

Machines

TH 4-4 U

Hand Marking Tools

- Hand marking tool for marking the crimp shells of 1- and 2-piece fittings up to size -32
- Permanent and easy marking in hose assembling workshops
- Type holder with two lines makes it possible to print additional information on the shell or fittings



Primary Applications

Workshops and mobile service vehicles

Technical / Order Data

| | | |
|-----------------------------------------------------------------------------------------|--------------------|--------------------------|
| Hand Marking Tool TH 4-4 U including type case and quick-change stamping tool | Marking area | Ø O.D. 11.5 mm - 100 mm |
| | Dimensions | L 250 x W 340 x H 450 mm |
| | Type holder | 2 lines |
| | Weight | 35 kg |
| | Part Number | TH4-4U |
| Type case for TH 4-4 U | Part Number | UPTS 100 |
| Quick-change stamping tool for TH 4-4 U single line | Part Number | UPTH-11b-PW3 |
| Type holder for TH 4-4 U 2 lines | Part Number | UPTH-22b |

Stamping tool
UPTH-11b-PW3



Type case UPTS 100 content

Letters: 1x P, 1x N, 3x letters empty
Numbers: 6 x 1; 5 x 2,3,4,5; 4 x 6; 3 x 7,8,9; 4 x 0
Neutral: 1x 15 mm, 1x 30 mm + brush, tweezers, key

TH 6-6

Cleaning System

- Cleaning device for hose and hose assemblies for hoses up to size -20
- Assemblies flushed with fluid and blown out with air
- Defined cleanliness levels can be achieved
- Air connection min. 0.7 MPa required



Technical / Order Data

| | | |
|--------------------------------------------------------|---------------------|--------------------------------|
| | Air pressure | min. 0.7 MPa |
| | Flow | 25 l/min |
| | Air consumption | max. 100 NI/min |
| | Length | (depending on I.D.) max. 2.5 m |
| | Dimensions | L 960 x W 435 x H 940 mm |
| | Weight | 55 kg |
| | with cleaning fluid | 93 kg |
| | Part Number | TH6-6 |
| Cleaning Machine TH 6-6 | Part Number | H899959 |
| Filter set without cartridges | Part Number | 600.4 |
| Filter cartridges 5 µm | Part Number | H899771 |
| Neutral cleaning fluid additive (30 litre drum) | Part Number | H899771 |

TH 6-7

Cleaning System

- Quick and simple system using compressed air to clean hoses
- Delivered with two plastic nozzles for hoses from size -4 up to -32

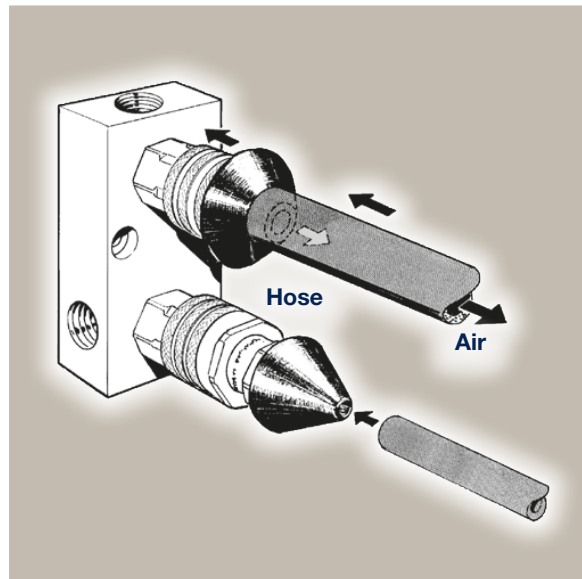

Primary Applications

The hose is pressed against the nozzle and thereby opens a valve to allow the compressed air to blow through the hose and blow out loose particles.

Technical / Order Data

| | | |
|---------------------------------------------------------------------------|--------------------|-------------------------|
| Cleaning System TH 6-7 with two plastic nozzles in 30 and 55 mm | Air pressure | min. 0.6 MPa |
| | Air connection | 1/2" BSP |
| | Dimensions | L 120 x W 50 x H 100 mm |
| | Weight | 0.3 kg |
| | Part Number | TH6-7 |
| Nozzle 30 mm | Part Number | TH6-7-30 |
| Nozzle 55 mm | Part Number | TH6-7-55 |

TH 6-10-EL-8

Ultra Clean Kit

- Cleaning of hoses from size -4 up to -20
- Reduces downtime and risk of hose failure
- Has a quarter-turn locking ring for easy nozzle change and projectile loading
- Durable brass and aluminium internals, strong plastic handle, and anodized aluminium firing head and locking ring



Primary Applications

Workshops and mobile service vehicles

Restrictions

5 micron filter and regulator with gauge are strongly suggested

Technical / Order Data

Ultra Clean Kit TH 6-10-EL-8 with case, launcher in size -20, nozzles in size -4, -5, -6, -8, -10, -12, -16 and -20 (1 each)

| | |
|--------------------|--------------------------------|
| Air pressure | min. 0.55 MPa max. 0.75 MPa |
| Air connection | 1/2" I.D. air hose |
| Dimensions | L 407 x W 134 x H 343 mm |
| Weight | 4 kg |
| Part Number | TH6-10-EL-8 |

Nozzles and Projectiles for Ultra Clean Kit TH6-10-EL-8

| Hose Size | Nozzle Part Number | Projectile Part Number |
|-----------|--------------------|------------------------|
| -4 | TH6-10-H06 | TH6-10-P10 |
| -5 | TH6-10-H08 | TH6-10-P12 |
| -6 | TH6-10-H10 | TH6-10-P14 |
| -8 | TH6-10-H13 | TH6-10-P18 |
| -10 | TH6-10-H16 | TH6-10-P22 |
| -12 | TH6-10-H19 | TH6-10-P26 |
| -16 | TH6-10-H25 | TH6-10-P33 |
| -20 | TH6-10-H32 | TH6-10-P40 |

Machines

TH 6-10-HL-10-2

Ultra Clean Kit

- Cleaning of hoses from size -4 up to -32
- Reduces downtime and risk of hose failure
- Full-flow quick release coupling and unique 360° rotary plug for proper air flow and non-fatigue operator use
- Aluminium, fully anodized for harsh environments and heavy use
- Unique safety release bar that locks the faceplate into a closed position for firing Ultra Clean projectiles



Primary Applications

Workshops and mobile service vehicles

Restrictions

5 micron filter and regulator with gauge are strongly suggested

Technical / Order Data

Ultra Clean Kit TH 6-10-HL-10-2 with case, launcher in size -32, nozzles in size -4, -5, -6, -8, -10, -12, -16, -20, -24 and -32 (1 each)

| | |
|--------------------|--------------------------------|
| Air pressure | min. 0.55 MPa max. 0.75 MPa |
| Air connection | 1/2" I.D. air hose |
| Dimensions | L 407 x W 134 x H 343 mm |
| Weight | 5 kg |
| Part Number | TH6-10-HL-10-2 |

Nozzles and Projectiles for Ultra Clean Kit TH6-10-HL-10-2

| Hose Size | Nozzle Part Number | Projectile Part Number |
|-----------|--------------------|------------------------|
| -4 | TH6-10-H06 | TH6-10-P10 |
| -5 | TH6-10-H08 | TH6-10-P12 |
| -6 | TH6-10-H10 | TH6-10-P14 |
| -8 | TH6-10-H13 | TH6-10-P18 |
| -10 | TH6-10-H16 | TH6-10-P22 |
| -12 | TH6-10-H19 | TH6-10-P26 |
| -16 | TH6-10-H25 | TH6-10-P33 |
| -20 | TH6-10-H32 | TH6-10-P40 |
| -24 | TH6-10-H38 | TH6-10-P50 |
| -32 | TH6-10-H50 | TH6-10-P60 |



TH 5-3

Hose Assembly Test Bench up to 145.0 MPa

- Totally sealed test chamber
- Safety interlock – pressure automatically decreases within 1/10 sec. when the test chamber is opened
- Rapid fill and automatic air bleeding of the test piece
- Weight-compensated protection cover with safety windows
- Bio-degradable water-oil emulsion as test medium
- Simple operation



Primary Applications

Service and series production in workshops. The hose assembly test bench makes the efficient and safe final inspection of hose assemblies practical and fast. Static pressure testing of other hydraulic components is also possible.

Restrictions

This test bench is not designed for burst pressure testing. Due to the limited flexibility of large bore multispiral hoses it is not ideal for size -24 and size -32 pressure testing.

Technical / Order Data

Hose Assembly Test Bench TH 5-3
incl. HD adapter set

| | |
|-----------------------|------------------------------------|
| Test pressure | 12.0 - 145.0 MPa |
| Drive | intensifier |
| Compressed air rating | 0.7 MPa, 20 NI/min |
| Pressure regulator | manual |
| Test medium | water-oil emulsion |
| Safety control unit | yes |
| Tank capacity | 100 l |
| Colour | black / silver |
| Dimensions | L 2210 x W 840 x H 1260 mm |
| Weight | empty 210 kg with medium 310 kg |
| Accessories | filter 100 µm, air service unit |
| Part Number | TH5-3 |

Hose Assembly Test Bench TH 5-3-BM
with result recording unit

Part Number TH5-3-BM

HD adapter set

Part Number 405.906

Corrosion protection, 20 l

Part Number H899770

TH 7-12

7-stage hose reel

- Seven-stage reel for hoses from size -4 up to -20
- Every stage (except bottom stage) can be swung out horizontally so that new rolls can easily be inserted



Technical / Order Data

Hose Reel TH 7-12

for service and series production in workshops

| | |
|--------------------|-----------------------------|
| Reel dimensions | |
| Int. Ø min. / max. | 250 mm / 1010 mm |
| Height max. | 300 mm |
| Max. load per reel | 80 kg |
| Colour | zinc plated |
| Dimensions | L 1270 x W 1000 x H 2230 mm |
| Weight | 148 kg |
| Part Number | TH7-12 |

TH 7-13

1-stage hose reel

- One-stage reel for hoses from size -4 up to -32
- Table adjustable to fit the center of the coil



Technical / Order Data

Hose Reel TH 7-13

for service and series production in workshops

| | |
|--------------------|----------------------------|
| Reel dimensions | |
| Int. Ø min. / max. | adjustable 150 - 500 mm |
| Max. load of reel | 500 kg |
| Colour | zinc plated / grey |
| Dimensions | L 1200 x W 1200 x H 830 mm |
| Weight | 40 kg |
| Part Number | TH7-13 |

TH 7-14

Horizontal motorized hose reel

- Motorized reel for hoses fromsize -4 up to -32
- Variable speed control in both directions
- Ideal for cutting long lengths where coiling is necessary



Technical / Order Data

Hose Reel TH 7-14

for service and series production in workshops

| | |
|--------------------|--------------------------|
| Reel dimensions | |
| Int. Ø min. / max. | adjustable 150 - 500 mm |
| Max. load of reel | 500 kg |
| Electric power | 230 V / 10 A / 50 Hz |
| Colour | zinc plated / light grey |
| Dimensions | W 1200 x H 830 mm |
| Weight | 65 kg |
| Part Number | TH7-14 |

TH 7-15

Vertical motorized hose reel

- Motorized reel for hoses fromsize -4 up to -20
- Variable speed control in both directions
- Ideal for cutting long lengths where coiling is necessary
- Very easy to unload

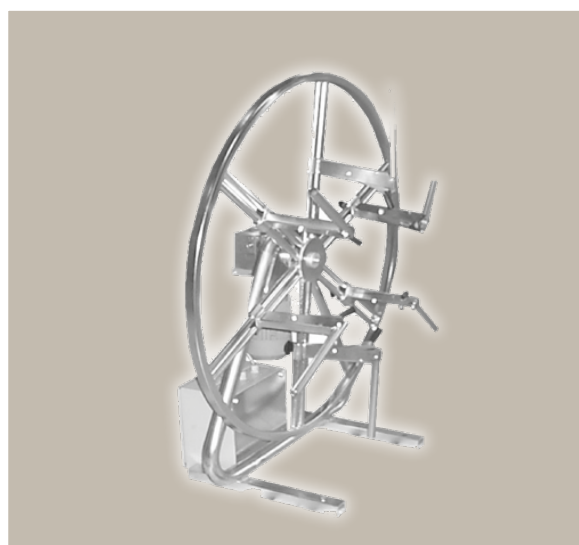

Technical / Order Data

Hose Reel TH 7-15

for service and series production in workshops

| | |
|--------------------|-------------------------|
| Reel dimensions | |
| Int. Ø min. / max. | adjustable 250 - 800 mm |
| Max. load of reel | 100 kg |
| Electric power | 230 V / 10 A / 50 Hz |
| Colour | zinc plated |
| Dimensions | W 600 x H 1400 mm |
| Weight | 75 kg |
| Part Number | TH7-15 |

Machines

Adjustable Crimper

TH 8E-200, -200VDC, -200-ECO, -200-24VDC

TH 8E-200, -200VDC, -200-ECO, -200-24VDC

Strong Crimping Press

- Crimps
 - all Parker *No-Sliver* hoses up to size -24
 - ParLock and Compact Spiral hoses up to size -16
- Easy installation on the workbench in the workshop area or in the van
- For die sets series 239

Primary Applications

Hose assembly workshops with small series production and services.

Restrictions

Not for ParLock hose fittings in size -20, -24 and -32 (fittings series V4 and V6).



| | | |
|---------------------------------------------------------------------------------------------------------------------------------------------------------------------------|--------------------|-------------------------------------|
| All TH 8E-200 with | Crimp force | 130 t |
| | Crimp range | 70 mm |
| – die set packet PBSET-TH8E-200 | Noise level | 69 dBA |
| | Colour | black/silver |
| – quick change tool QDC239.5 | Electrical power | 400 V / 50 Hz / 3 PH / 3 kW |
| | Control system | micrometer |
| Attention: Delivery without oil or connecting plug | Dimensions | L 800 x B 530 x H 560 mm |
| | Oil quantity | 40 l |
| TH 8E-200 | Weight | 140 kg |
| | Part Number | TH8E-200 |
| TH 8E-200-ECO | Electrical power | 400 V / 50 Hz / 3 PH / 3 kW |
| | Control system | micrometer |
| TH 8E-200-ECO | Dimensions | L 420 x B 535 x H 520 mm |
| | Oil quantity | 40 l |
| TH 8E-200VDC, TH 8E-200-24VDC | Weight | 88 kg |
| | Part Number | TH8E-200-ECO |
| TH 8E-200VDC, TH 8E-200-24VDC | Electrical power | 12 V DC / 24 V DC |
| | Control system | micrometer |
| TH 8E-200VDC, TH 8E-200-24VDC | Dimensions | L 420 x B 535 x H 520 mm |
| | Oil quantity | 4 l |
| TH 8E-200VDC, TH 8E-200-24VDC | Weight | 88 kg |
| | Part Number | TH 8E-200VDC/TH 8E-200-24VDC |
| Adapter die set, Ø 12–54: PB239-12 PB239-14 PB239-17 PB239-20 PB239-22 PB239-24 PB239-26 PB239-28 PB239-31 PB239-32 PB239-36 PB239-38 PB239-40 PB239-44 PB239-50 PB239-54 | | |
| | Part Number | PBSET-TH8E-200 |
| Quick change tool | Part Number | QDC239.3 |

TH 8E-530, TH 8E-535-CM

Strong Crimping Press

- Crimps
 - all Parker *No-Sliver* fittings up to size -32 (except Compact Spiral size -32)
- Easy installation on the workbench in the workshop area or in the van
- For die sets series 239L and 266 (adapter die set PB266.239L required)



Primary Applications

Hose assembly workshops with small series production and services.

All TH 8E-530 and TH 8E-535 with
– adapter die set PB266.239L
– die set packet (14 mm – 74 mm) PBSET-TH8E-53X
– quick change tool QDC239.5
Attention: Delivery without oil or connecting plug

TH 8E-530

TH 8E-530-CM

TH 8E-535-CM

Adapter die set, Ø 12–74: PB239-65-12, PB239-65-14, PB239-65-17, PB239-65-20, PB239-65-22, PB239-65-24, PB239-65-26, PB239-80-28, PB239-80-31, PB239-80-32, PB239-80-36, PB239-80-38, PB239-80-40, PB239-80-44, PB239-100-50, PB266L-54, PB266L-57, PB266L-62, PB266L-67, PB266L-71, PB266L-74

| | |
|--------------------------------------------------|-----------------------------------|
| Part Number | PB266.239L |
| Die rack | Part Number QDS239S |
| Die set packet , diameter from 14 – 74 mm | Part Number PBSET-TH8E-53X |
| Quick change tool | Part Number QDC239.5 |

Restrictions

Not for ParLock hose fittings in size -20, -24 and -32 (fittings series V4 and V6).

| | |
|-------------------------|------------------------------------|
| Crimp force | 200 t |
| Crimp range | 94 mm |
| Noise level | 69 dBA |
| Colour | black/silver |
| Electrical power | 400 V / 50 Hz / 3 PH / 4 kW |
| Control system | micrometer |
| Dimensions | L 700 x W 600 x H 735 mm |
| Oil quantity | 50 l |
| Weight | 248 kg |
| Part Number | TH8E-530 |
| Electrical power | 230-480 V / 50-60 Hz / 3 PH / 4 kW |
| Control system | C-Touch |
| Dimensions | L 700 x W 600 x H 735 mm |
| Oil quantity | 50 l |
| Weight | 255 kg |
| Part Number | TH8E-530-CM |
| Electrical power | 230-480 V / 50-60 Hz / 3 PH / 4 kW |
| Control system | C-Touch |
| Dimensions | L 690 x W 600 x H 1053 mm |
| Oil quantity | 55 l |
| Weight | 375 kg |
| Part Number | TH8E-535-CM |

TH8E-800-CM

Strong Crimping Press

- Crimps
 - all Parker *No-Sliver* fittings up to size -32
 - Industrial hose up to 4" (DN 100)
 - SAE 100 R13 / SAE 100 R15 hose
with Parker *No-Sliver* fittings up to size -32
 - SAE 100 R15 hose
with ParLock fittings V4 and V6 ... up to size -20
- Adjustable crimper electronic system C and 3 different crimp programs, manual opening and closing, semi-automatic opening and closing, semi-automatic opening and closing with foot switch or depth stop
- It is possible to crimp small diameters with an adapter die set



Primary Applications

Hose assembly workshops with small series production and services at certified distributors, ParkerStores and hose workshops in the maintenance areas at OEM customers

Restrictions

Not for ParLock hose fittings in size -24 and size-32 (fittings series V4 and V6).
There could be interference with long drop elbow fittings.

Technical / Order Data

Crimping Press TH8E-800-CM with

- adapter die set PB237.239.2L2
- quick change tool QDC239.5
- die set packet (12 mm – 74 mm) PBSET-TH8-800

Attention: Delivery without oil or connecting plug

| | |
|-------------------|---------------------------------------|
| Electrical power | 230-480 V / 50-60 Hz / 3 PH / 4 kW |
| Crimp force | 220 t |
| Control system | C-Touch |
| Crimp range | 139 mm |
| Noise level | 70 dB (A) |
| Colour | black/silver |
| Dimensions | L 690 x W 720 x H 1400 mm |
| Oil tank capacity | 70 l |
| Weight | without oil 440 kg with oil 510 kg |

TH8E-800

Adapter die set

Depth stop

Die rack

Die set packet, Ø 12 – 74: PB239-65-12, PB239-65-14, PB239-65-17, PB239-65-20, PB239-65-22, PB239-65-24, PB239-65-26, PB239-80-28, PB239-80-31, PB239-80-32, PB239-80-36, PB239-80-38, PB239-80-40, PB239-80-44, PB239-100-50, PB237L-54, PB237L-57, PB237L-62, PB237L-67, PB237L-71, PB237L-74

Foot switch

Mirror set

Quick change tool

| | |
|--------------------|-----------------------------|
| Part Number | TH8E-800-CM |
| Electrical power | 400 V / 50 Hz / 3 PH / 4 kW |
| Control system | micrometer |
| Part Number | TH8E-800 |
| Part Number | PB237.239.2L2 |
| Part Number | TA800/A |
| Part Number | QDS239S |
| Part Number | PBSET-TH8E-800 |
| Part Number | FU-HMX |
| Part Number | SHS-800 |
| Part Number | QDC239.5 |



TH 8E-380-CM

Heavy-Duty Crimping Press

- Crimps
 - all Parkrimp and ParLock hose types including 4 and 6 spiral steel wire
 - DIN 4SP/4SH, SAE 100 R13 / R15 Multispiral hoses up to size -32
 - all Parker industrial hoses up to 4" (DN 100)



Primary Applications

Heavy-duty crimper for crimping multispiral hoses in workshops for series production. Suitable for all standard Parker hoses.

Restrictions

Special hose assemblies with 2 elbows in extremely long version.

Technical / Order Data

TH 8E-380-CM with

- Adapter die set package PB237.239.2L2
- Quick change tool QDC239.5
- Die set package PBSET-TH8-380

For V4 and V6 fittings above size -16 long die sets are required (e.g. PB 237L-57)

Attention: Delivery without oil and connecting plug

| | |
|-------------------------------|------------------------------------|
| Electrical power | 230-480 V / 50/60 Hz / 3 PH / 4 kW |
| Crimp force | 340 t |
| Control system | Control C + Touch |
| Crimp range | 161 mm |
| Type of dies | 237L / 239L |
| Open / Close speed | 33 / 23 mm/s |
| Noise level | 62 dB (A) |
| Dimensions | L 1200 x W 600 x H 1700 mm |
| Weight without oil / with oil | 750 kg / 840 kg |

Adapter die set package 237/239L

Part Number TH8E-380-CM

Depth Stop Automatic

Part Number PB237.239.2L2

Die rack

Part Number TA380/A

Die set package, Ø 12 – 78: PB239-65-12, PB239-65-14, PB239-65-17, PB239-65-20, PB239-65-22, PB239-65-24, PB239-65-26, PB239-80-28, PB239-80-31, PB239-80-32, PB239-80-36, PB239-80-38, PB239-80-40, PB239-80-44, PB239-100-50, PB237L-54, PB237L-57, PB237L -62, PB237L -67, PB237L-71, PB237L-74, PB237L-78

PBSET-TH8E-380

Die set package optional Ø 84 – 131: PB237L-84, PB237L-86, PB237L-90, PB237L-96, PB237L-103, PB237L-106, PB237L-111, PB237L-116, PB237L-121, PB237L-126, PB237L-131

Part Number PBSET-237L-IH

Foot switch

Part Number FU-HMX

Mirror set

Part Number SHS375-380

Quick change tool

Part Number QDC239.5

Workplace lamp

Part Number TH8-LUS

TH 8E-480-CM

Heavy-Duty Crimping Press

- Crimps
 - all Parkrimp and ParLock hose types including 4 and 6 spiral steel wire
 - DIN 4SP/4SH, SAE 100 R13 / R15 Multispiral hoses up to size -48
 - all Parker industrial hoses up to 8"
- Compact design
- Safe positioning on the fixed 6 o'clock die
- Slide bearings on the crimp tool, no service and 20% less friction



Primary Applications

Heavy Duty Crimping Press for service and series production at workshops

Technical / Order Data

| | | |
|-----------------------------------------------------|--------------------|--------------------------------------|
| | Electrical power | 230-480 V / 50-60 Hz / 3 PH / 5.5 kW |
| | Crimp force | 450 t |
| | Control system | C-Touch |
| | Crimp range | 310 mm |
| | Open speed | 20 mm/s |
| | Crimp speed | 1.5 mm/s |
| | Close speed | 23 mm/s |
| | Noise level | 62 dB (A) |
| | Dimensions | L 730 x W 1590 x H 2015 mm |
| | Weight without oil | 2600 kg |
| | Oil capacity | 300 l |
| | Part Number | TH8E-480-CM |
| TH 8E-480-CM with | Part Number | PB245.237L |
| • Adapter die set package PB245.237L | Part Number | PB237.239.2L2 |
| • Adapter die set package PB237.239.2L2 | Part Number | QDC239.5 |
| • Quick change tool QDC239.5 | Part Number | TH8-LUS |
| • Die set package PBSET-TH8-380 | | |
| Attention: Delivery without oil and connecting plug | | |
| Adapter die set PB245.237L | Part Number | PB245.237L |
| Adapter die set PB237.239.2L2 | Part Number | PB237.239.2L2 |
| Quick change tool | Part Number | QDC239.5 |
| Workplace lamp | Part Number | TH8-LUS |

TH 2-9

Hose Skiving Machine

- Efficient skiving of hydraulic hoses (external and internal) from size -4 up to -32
- Easily controlled by a footpedal
- Waste collection bin



Primary Applications

For small series and service application.

Restrictions

Not recommended for series production.

Technical / Order Data

| | | | |
|-------------------------------------------------------------|---------------------------------|---------------------------------------|-------------------|
| Hose Skiving Machine TH 2-9 without skiving tools | Hose capacity, external skiving | 4 and 6 layer | size -4 up to -32 |
| | Hose capacity, internal skiving | 4 and 6 layer | size -6 up to -32 |
| | Speed | 125 rpm | |
| | Colour | light grey | |
| Hose Skiving Machine TH 2-9-3PH 3 phases, 400 V | Dimensions | L 600 x W 410 x H 390 mm | |
| | Weight | 35 kg | |
| Hose Skiving Machine TH 2-9-1PH 1 phase, 230 V | Electrical power | 3 PH / 400 V / 50 Hz / 16 A / 0.37 kW | |
| | Part Number | TH2-9-3PH | |
| Hose Skiving Machine TH 2-9-1PH 1 phase, 230 V | Electrical power | 1 PH / 230 V / 50 Hz / 10 A / 0.37 kW | |
| | Part Number | TH2-9-1PH | |



Internal
skiving tool



External
skiving tool
with one external tool

Skiving tools see page **Ea-29**

TH 2-10-3PH

Hose Skiving Machine

- Efficient skiving of hydraulic hoses (external and internal) from size -4 up to -32
- Semi-automatic electro-pneumatic control-system
- Adjustable pressure and speed
- Automatic self-centering system
- Waste collection bin



Primary Applications

Mainly for hose assembly workshop production for medium and large series.

Restrictions

Work cycle for internal and external skiving takes place separately, not in one step.

Technical / Order Data

Hose Skiving Machine TH 2-10-3PH without skiving tools

| | |
|---------------------------------|--------------------------------------|
| Hose capacity, external skiving | |
| 4 and 6 layer | size -4 up to -32 |
| Hose capacity, internal skiving | |
| 4 and 6 layer | size -6 up to -32 |
| Speed | 315 rpm |
| Air pressure | min. 0.7 MPa |
| Colour | light grey |
| Electrical power | 3 PH / 400 V / 50 Hz / 16 A / 1.2 kW |
| Dimensions | L 680 x W 1200 x H 1080 mm |
| Weight | 132 kg |
| Part Number | TH2-10-3PH |



Internal
skiving tool



External
skiving tool
with two external tools

Skiving tools see page **Ea-29**

TH 2-13-3PH

Twin-Skive Machine

- Twin-skiving of hydraulic hoses (external and internal) from size -4 up to -32 in one operation
- Semi-automatic electro-pneumatic control-system
- Automatic self-centring system
- Adjustable pressure and speed
- Waste collection bin
- Eliminates work-related injuries



Primary Applications

For hose assembly workshops for series production.

Restrictions

Max. hose outside diameter 75 mm for external skiving.

Technical / Order Data

Hose Skiving Machine TH 2-13-3PH without skiving tools

| | |
|---------------------------------|-------------------------------------------|
| Hose capacity, external skiving | |
| 4 and 6 layer | size -4 up to -32 |
| Hose capacity, internal skiving | |
| 4 and 6 layer | size -6 up to -32 |
| Speed | 400 / 315 rpm |
| Air pressure | min. 0.7 MPa |
| Colour | light grey |
| Electrical power | 3 PH / 400 V / 50 Hz / 16 A / 2 x 0.75 kW |
| Dimensions | L 680 x W 1200 x H 1080 mm |
| Weight | 150 kg |
| Part Number | TH2-13-3PH |

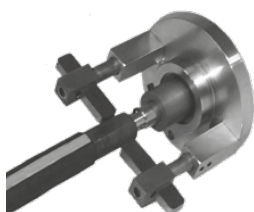

Skiving tool

Skiving tools see page **Ea-29**

Skiving Tools for TH 2-9, TH 2-10-3PH und TH 2-13-3PH

Internal skiving tool for TH 2-9, TH 2-10-3PH and TH 2-13-3PH

| Internal skiving tool TH 2-9 and TH 2-10-3PH | Size | Internal skiving tool (without knife) | Internal skiving knife |
|----------------------------------------------------------------------------------------------------------------|------|------------------------------------------|------------------------|
| | | Part Number | Part Number |
|  A: Internal skiving knife | -6 | TH2-12-NT-6 | TH2-12NK-6 |
| | -8 | TH2-12-NT-8 | TH2-12NK-8 |
| | -10 | TH2-12NT-10 | TH2-12NK-1012 |
| | -12 | TH2-12NT-12 | |
| | -16 | TH2-12NT-16 | TH2-12NK-1620 |
| | -20 | TH2-12NT-20 | |
| | -24 | TH2-12NT-24 | TH2-12NK-2432 |
| | -32 | TH2-12NT-32 | |

External skiving tool for TH 2-9 and TH 2-10-3PH

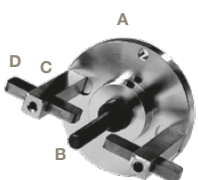
| External skiving tool TH 2-9 and TH 2-10-3PH | Size | Mandrel Size Part Number | External skiving tool (without knife) | Additional arm | External skiving knife |
|---------------------------------------------------------------------------------------------------------------------------------------------------------------------------------------------------------------------|------------|-----------------------------|------------------------------------------|--------------------------------------------|---------------------------|
| | | | Part Number | Part Number | Part Number |
|  A: External skiving tool holder B: Mandrel for external skiving C: Holder for skiving tool D: External skiving knife | -4 | TH2-11M-4 | short arm TH2-11ES | short arm TH2-11ES-1 TH2-10-3PH only | TH2-11EK |
| | -6 | TH2-11M-6 | | | |
| | -8 | TH2-11M-8 | | | |
| | -10 | TH2-11M-10 | long arm TH2-11EL | long arm TH2-11EL-1 TH2-10-3PH only | |
| | -12 | TH2-11M-12 | | | |
| | -16 | TH2-11M-16 | | | |
| | -20 | TH2-11M-20 | | | |
| -24 | TH2-11M-24 | | | | |
| -32 | TH2-11M-32 | | | | |

Internal and external skiving tool for TH 2-13-3PH

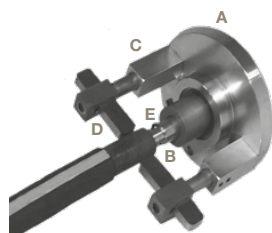

Skiving tool
 A: Tooling holder complete
 B: Mandrel for internal skiving
 C: Holder for external skiving knife
 D: External skiving knife
 E: Internal skiving knife

| Internal and external skiving tool TH 2-13-3PH | Size | | Mandrel Size Part Number | Internal skiving knife Part Number | External skiving toolholder Part Number | Additional arm | External skiving knife |
|------------------------------------------------------|------|------------|-----------------------------|------------------------------------------|-----------------------------------------------|----------------|---------------------------|
| | | | | | | Part Number | Part Number |
| | -6 | external | TH2-11M-6 | | TH2-11ES | TH2-13ET | TH2-11EK |
| | | internal | TH2-12NT-6 | TH2-12NK-6 | | | |
| | -8 | | TH2-13M-8 | TH2-12NK-8 | short arm TH2-13ES-1 | | |
| | -10 | | TH2-13M-10 | TH2-12NK-1012 | | | |
| | -12 | | TH2-13M-12 | TH2-12NK-1620 | long arm TH2-13EL-1 | | |
| | -16 | | TH2-13M-16 | TH2-12NK-2432 | | | |
| | -20 | | TH2-13M-20 | | | | |
| | -24 | | TH2-13M-24 | | | | |
| -32 | | TH2-13M-32 | | | | | |

Clean Seal Capsules

The Clean Seal capsule is a simple, easy and clean alternative to cap your hose and fitting assemblies. The Clean Seal cap enables a secure fit due to an easy to use heat shrink system. Reduce your cap complexity as one Clean Seal cap will seal multiple end configurations and sizes, eliminating many unique traditional caps.

The Clean Seal process utilizes heat shrink technology to cover the end of a hose assembly. The heat shrink technology eliminates problems due to re-contamination issues. When traditional caps and plugs are forced onto assemblies, plastic debris and particles shred off into your hose, ultimately causing re-contamination.



| Packaged | | Bulk | | Length mm | Hex Sizes Covered | |
|-------------|----------|-------------|----------|--------------|----------------------|---------|
| Part Number | Quantity | Part Number | Quantity | | Inch | mm |
| PCS-2023P | 810 | PCS-2023B | 23400 | 23 | 0.47 - 0.71 | 12 - 18 |
| PCS-2030P | 810 | PCS-2030B | 23400 | 30 | 0.47 - 0.71 | 12 - 18 |
| PCS-2224P | 810 | PCS-2224B | 23500 | 24 | 0.63 - 0.83 | 16 - 21 |
| PCS-2527P | 800 | PCS-2527B | 17600 | 27 | 0.71 - 0.91 | 18 - 23 |
| PCS-2540P | 800 | PCS-2540B | 17600 | 40 | 0.71 - 0.91 | 18 - 23 |
| PCS-2840P | 720 | PCS-2840B | 15200 | 40 | 0.87 - 1.02 | 22 - 26 |
| PCS-3133P | 640 | PCS-3133B | 12240 | 33 | 0.94 - 1.14 | 24 - 29 |
| PCS-3140P | 640 | PCS-3140B | 12240 | 40 | 0.94 - 1.14 | 24 - 29 |
| PCS-3440P | 640 | PCS-3440B | 10240 | 40 | 1.07 - 1.26 | 27 - 32 |
| PCS-3840P | 560 | PCS-3840B | 7800 | 40 | 1.09 - 1.42 | 30 - 36 |
| PCS-4345P | 480 | PCS-4345B | 6240 | 45 | 1.26 - 1.61 | 32 - 41 |
| PCS-4650P | 480 | PCS-4650B | 5760 | 50 | 1.34 - 1.73 | 34 - 44 |
| PCS-5260P | 400 | PCS-5260B | 4400 | 60 | 1.62 - 1.97 | 41 - 50 |
| PCS-5860P | 400 | PCS-5860B | 3600 | 60 | 1.93 - 2.20 | 49 - 56 |
| PCS-6760P | 320 | PCS-6760B | 2560 | 60 | 2.16 - 2.56 | 55 - 65 |

Example: PCS-AA \overline{BB} X → Example: **PCS-4650B**

AA = \varnothing A

BB = length B

X = quantity

B = bulk

P = package

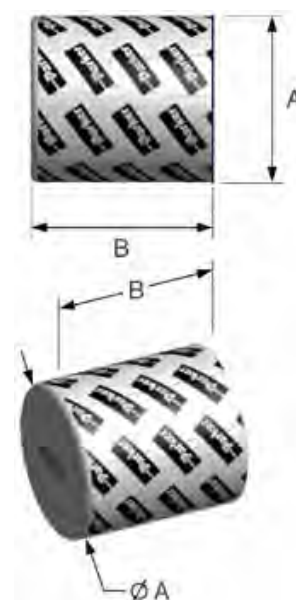

Removal is an easy 3-step process.



UC-CSS-230VE

Production Heat Shrink machine

- Simple, easy and clean alternative to cap hose and fitting assemblies
- Secure fit due to an easy to use heat shrink system
- Heat shrink technology eliminates problems due to re-contamination issues
- For use on fittings up to -24 (1-1/2")
- Fits straight and elbow fittings
- Easy pull tab removal
- Reduced environmental impact compared to traditional caps: less plastic used, more crushable
- Multiple hoses can be capped at one time



Primary Applications

For hose assembly workshops for series production.



Technical / Order Data

Production Heat Shrink machine
with timer

| | |
|--------------------|------------------------|
| Fitting | up to size -24 |
| Electrical power | 230 V / 50/60 Hz |
| Dimensions | 241 x 520 x 180 mm |
| Weight | 11.8 kg |
| Part Number | UC-CSS-230VE-G2 |

Electric heat gun
with case

| | |
|--------------------|-----------------------|
| Fitting | up to size -24 |
| Electrical power | 230 V / 50/60 Hz |
| Dimensions | 330 x 330 x 127 mm |
| Weight | 2.7 kg |
| Part Number | UC-HL-1920E-EU |

Flex vacuum pumpstand

| | |
|--------------------|--------------------|
| Part Number | UC-HG-STAND |
|--------------------|--------------------|

Diffuser, 95 mm, 1-1/2" heat gun connection

| | |
|--------------------|-----------------|
| Part Number | UC-1.5HD |
|--------------------|-----------------|



Flex vacuum pumpstand



Diffuser

Push-Lok® Assembly Tools 611050G and 611050HV

Tool designed for assembly of Push-Lok® fittings and hoses in all sizes. Toggle actions greatly reduce effort necessary to hold hose and press in fitting. Only a few pounds of force is needed on either handle to quickly assemble any size.

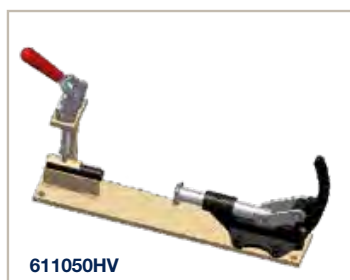

Hose Fitting Insertion Device TH1E-5

for straight and elbow nipples and fittings.

The TH1E-5 is the first manual fitting insertion device for the assembly or pre-assembly of low, medium and high pressure hose assemblies up to size -20. Straight fittings are using an insertion cone or insertion mandrel while bended fittings are inserted into the hose using an insertion disk.

The hose is simply fixed in the clamping unit and the nipple or the fitting is slightly pushed by hand into the hose.

Subsequently the insertion unit which is equipped with insertion cone, mandrel, or disc is pushed to the left by hand lever until the nipple or fitting is completely inserted into the hose.



Technical / Order Data

| | | |
|--------------------------------------------------|--------------------|--------------------------|
| Assembly Tool 611050G | Overall length | 320 mm |
| | Weight | 2,2 kg |
| | Part Number | 611050G |
| Assembly Tool 611050HV "Rigid version" | Dimensions | L 500 x B 90 x H 300 mm |
| | Weight | 7,5 kg |
| | Part Number | 611050HV |
| Hose Fitting Insertion Device TH1E-5 | Dimensions | L 650 x B 250 x H 140 mm |
| | Weight | 25 kg |
| | Part Number | TH1E-5 |

Flange Halves

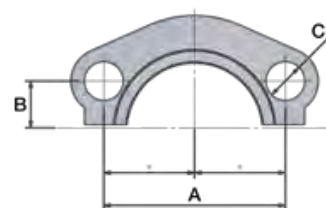

FHS (M1H) – ISO 6162-1 Flange Half – Standard Series

(for use with 15, 17 and 19 flanges)

| Part Number | | Flange | | | A | B | C | max. dynamic working pressure | |
|-------------|----------|--------|-------|------|-------|------|------|-------------------------------|------|
| NEW | OLD | DN | Inch | Size | mm | mm | mm | MPa | psi |
| FHS32CFX | (M1H-8) | 13 | 1/2 | -8 | 38.1 | 8.8 | 8.9 | 34.5 | 5000 |
| FHS33CFX | (M1H-12) | 19 | 3/4 | -12 | 47.6 | 11.1 | 10.6 | 34.5 | 5000 |
| FHS34CFX | (M1H-16) | 25 | 1 | -16 | 52.4 | 13.1 | 10.6 | 34.5 | 5000 |
| FHS35CFX | (M1H-20) | 32 | 1-1/4 | -20 | 58.7 | 15.1 | 12.0 | 28.0 | 4000 |
| FHS36CFX | (M1H-24) | 38 | 1-1/2 | -24 | 69.9 | 17.9 | 13.3 | 21.0 | 3000 |
| FHS38CFX | (M1H-32) | 51 | 2 | -32 | 77.8 | 21.5 | 13.5 | 21.0 | 3000 |
| FHS310CFX | (M1H-40) | 64 | 2-1/2 | -40 | 88.9 | 25.4 | 13.5 | 17.5 | 2538 |
| FHS312CFX | (M1H-48) | 76 | 3 | -48 | 106.4 | 31.0 | 16.7 | 16.0 | 2321 |
| FHS314CFX | (M1H-56) | 89 | 3-1/2 | -56 | 120.7 | 35.0 | 16.7 | 3.5 | 508 |
| FHS316CFX | (M1H-64) | 102 | 4 | -64 | 130.2 | 38.9 | 16.7 | 3.5 | 508 |
| FHS320CFX | (M1H-80) | 127 | 5 | -80 | 152.4 | 46.1 | 16.7 | 3.5 | 508 |

50H – ISO 6162-1 Flange Half 5000 psi

(for use with 4A, 4F and 4N flanges)

| Part Number | DN | Flange Inch | Size | A mm | B mm | C mm | max. dynamic working pressure | |
|-------------|----|-------------|------|------|------|------|-------------------------------|------|
| | | | | | | | MPa | psi |
| 50H-20 | 32 | 1-1/4 | -20 | 58.7 | 15.1 | 12.0 | 34.5 | 5000 |
| 50H-24 | 38 | 1-1/2 | -24 | 69.9 | 17.9 | 13.5 | 34.5 | 5000 |
| 50H-32 | 51 | 2 | -32 | 77.8 | 21.5 | 13.5 | 34.5 | 5000 |

FHS (M2H) – ISO 6162-2 Flange Half 6000 psi

(for use with 6A, 6F and 6N flanges)

| Part Number | | Flange | | | A | B | C | max. dynamic working pressure | |
|-------------|----------|--------|-------|------|-------|------|------|-------------------------------|------|
| NEW | OLD | DN | Inch | Size | mm | mm | mm | MPa | psi |
| FHS62CFX | (M2H-8) | 13 | 1/2 | -8 | 40.5 | 9.1 | 9.0 | 41.0 | 6000 |
| FHS63CFX | (M2H-12) | 19 | 3/4 | -12 | 50.8 | 11.9 | 11.0 | 41.0 | 6000 |
| FHS64CFX | (M2H-16) | 25 | 1 | -16 | 57.2 | 13.9 | 13.0 | 41.0 | 6000 |
| FHS65CFX | (M2H-20) | 32 | 1-1/4 | -20 | 66.7 | 15.9 | 15.0 | 41.0 | 6000 |
| FHS66CFX | (M2H-24) | 38 | 1-1/2 | -24 | 79.4 | 18.2 | 17.0 | 41.0 | 6000 |
| FHS68CFX | (M2H-32) | 51 | 2 | -32 | 96.8 | 22.2 | 22.0 | 41.0 | 6000 |
| FHS610CFX | (M2H-40) | 64 | 2-1/2 | -40 | 123.8 | 29.3 | 25.0 | 42.0 | 6000 |
| FHS612CFX | (M2H-48) | 76 | 3 | -48 | 152.4 | 35.7 | 31.0 | 42.0 | 6000 |

8FH – ISO 6162-2 Flange Half 8000 psi

(for use with 8A, 8F and 8N flanges)

| Part Number | DN | Flange Inch | Size | A mm | B mm | C mm | max. dynamic working pressure | |
|---------------|----|-------------|------|------|------|------|-------------------------------|------|
| | | | | | | | MPa | psi |
| 8FH-12-SM | 19 | 3/4 | -12 | 50.8 | 11.9 | 11.0 | 56.0 | 8000 |
| 8FH-16-SM | 25 | 1 | -16 | 57.2 | 13.9 | 13.0 | 56.0 | 8000 |
| 8FH-20-SM | 32 | 1-1/4 | -20 | 66.7 | 15.9 | 13.0 | 56.0 | 8000 |
| 8FH-20-SM-M14 | 32 | 1-1/4 | -20 | 66.7 | 15.9 | 15.0 | 56.0 | 8000 |



Accessories

Bolts for Flange Halves

Bolts for Flange Halves ISO 6162-1

FHS (M1H) – ISO 6162-1 Flange Half – Standard Series

(for use with 15, 17 and 19 flanges)



| Part Number | | | |  G Thread metric <i>Inch</i> | A mm <i>Inch</i> |  max. dynamic working pressure | |
|-----------------|-----|-------|------|----------------------------------------------------------------------------------------------------------------------------|----------------------------|-------------------------------------------------------------------------------------------------------------------------|------|
| | DN | Inch | Size | | | MPa | psi |
| ZYLS8X25VZX | 13 | 1/2 | -8 | M8x1.25 | 25 | 34.5 | 5000 |
| UNC5/16-18X11/4 | 13 | 1/2 | -8 | UNC5/16-18 | 11/4 | 34.5 | 5000 |
| ZYLS10X30VZX | 19 | 3/4 | -12 | M10x1.5 | 30 | 34.5 | 5000 |
| UNC3/8-16X11/4 | 19 | 3/4 | -12 | UNC3/8-16 | 11/4 | 34.5 | 5000 |
| ZYLS10X30VZX | 25 | 1 | -16 | M10x1.5 | 30 | 34.5 | 5000 |
| UNC3/8-16X11/4 | 25 | 1 | -16 | UNC3/8-16 | 11/4 | 34.5 | 5000 |
| ZYLS10X30VZX | 32 | 1-1/4 | -20 | M10x1.5 | 30 | 28.0 | 4000 |
| UNC7/16-14X11/2 | 32 | 1-1/4 | -20 | UNC7/16-14 | 11/2 | 28.0 | 4000 |
| ZYLS12X35VZX | 38 | 1-1/2 | -24 | M12x1.75 | 35 | 21.0 | 3000 |
| UNC1/2-13X11/2 | 38 | 1-1/2 | -24 | UNC1/2-13 | 11/2 | 21.0 | 3000 |
| ZYLS12X35VZX | 51 | 2 | -32 | M12x1.75 | 35 | 21.0 | 3000 |
| UNC1/2-13X11/2 | 51 | 2 | -32 | UNC1/2-13 | 11/2 | 21.0 | 3000 |
| ZYLS12X40VZX | 64 | 2-1/2 | -40 | M12x1.75 | 40 | 17.5 | 2538 |
| UNC1/2-13X13/4 | 64 | 2-1/2 | -40 | UNC1/2-13 | 13/4 | 17.5 | 2538 |
| ZYLS16X50VZX | 76 | 3 | -48 | M16x2 | 50 | 16.0 | 2321 |
| UNC5/8-11X13/4 | 76 | 3 | -48 | UNC5/8-11 | 13/4 | 16.0 | 2321 |
| ZYLS16X50VZX | 89 | 3-1/2 | -56 | M16x2 | 50 | 3.5 | 508 |
| UNC5/8-11X2 | 89 | 3-1/2 | -56 | UNC5/8-11 | 2 | 3.5 | 508 |
| ZYLS16X50VZX | 102 | 4 | -64 | M16x2 | 50 | 3.5 | 508 |
| UNC5/8-11X2 | 102 | 4 | -64 | UNC5/8-11 | 2 | 3.5 | 508 |
| ZYLS16X55VZX | 127 | 5 | -80 | M16x2 | 55 | 3.5 | 508 |
| UNC5/8-11X21/4 | 127 | 5 | -80 | UNC5/8-11 | 21/4 | 3.5 | 508 |

- metric bolts according to ISO 4762-10.9 (DIN 912-10.9)

- UNC bolts according to ANSI / ASME B18.3

50H – ISO 6162-1 Flange Half 5000 psi

(for use with 4A, 4F and 4N flanges)

| Part Number | | | |  G Thread metric <i>Inch</i> | A mm <i>Inch</i> |  max. dynamic working pressure | |
|-----------------|----|-------|------|------------------------------------------------------------------------------------------------------------------------------|----------------------------|---------------------------------------------------------------------------------------------------------------------------|------|
| | DN | Inch | Size | | | MPa | psi |
| - | 32 | 1-1/4 | -20 | - | - | 34.5 | 5000 |
| UNC7/16-14X11/2 | 32 | 1-1/4 | -20 | UNC7/16-14 | 11/2 | 34.5 | 5000 |
| - | 38 | 1-1/2 | -24 | - | - | 34.5 | 5000 |
| UNC1/2-13X11/2 | 38 | 1-1/2 | -24 | UNC1/2-13 | 11/2 | 34.5 | 5000 |
| - | 51 | 2 | -32 | - | - | 34.5 | 5000 |
| UNC1/2-13X11/2 | 51 | 2 | -32 | UNC1/2-13 | 11/2 | 34.5 | 5000 |

- metric bolts according to ISO 4762-10.9 (DIN 912-10.9)

- UNC bolts according to ANSI / ASME B18.3

Assembly torque see page **Ab-24**



Accessories

Bolts for Flange Halves

Bolts for Flange Halves ISO 6162-2

FHS (M2H) – ISO 6162-2 Flange Half 6000 psi

(for use with 6A, 6F and 6N flanges)



| Part Number | | | |  G Thread metric <i>Inch</i> | A mm <i>Inch</i> |  max. dynamic working pressure | |
|-----------------|----|-------|------|----------------------------------------------------------------------------------------------------------------------------|----------------------------|-------------------------------------------------------------------------------------------------------------------------|------|
| | DN | Inch | Size | | | MPa | psi |
| ZYLS8X25VZX | 13 | 1/2 | -8 | M8x1.25 | 25 | 42.0 | 6000 |
| UNC5/16-18X11/4 | 13 | 1/2 | -8 | UNC5/16-18 | 1-1/4 | 42.0 | 6000 |
| ZYLS10X35VZX | 19 | 3/4 | -12 | M10x1.5 | 35 | 42.0 | 6000 |
| UNC3/8-16X11/2 | 19 | 3/4 | -12 | UNC3/8-16 | 1-1/2 | 42.0 | 6000 |
| ZYLS12X45VZX | 25 | 1 | -16 | M12x1.75 | 45 | 42.0 | 6000 |
| UNC7/16-14X13/4 | 25 | 1 | -16 | UNC7/16-14 | 1-3/4 | 42.0 | 6000 |
| ZYLS12X45VZX | 32 | 1-1/4 | -20 | M12x1.75 | 45 | 42.0 | 6000 |
| UNC1/2-13X13/4 | 32 | 1-1/4 | -20 | UNC1/2-13 | 1-3/4 | 42.0 | 6000 |
| ZYLS16X55VZX | 38 | 1-1/2 | -24 | M16x2 | 55 | 42.0 | 6000 |
| UNC5/8-11X21/4 | 38 | 1-1/2 | -24 | UNC5/8-11 | 2-1/4 | 42.0 | 6000 |
| ZYLS20X65VZX | 51 | 2 | -32 | M20x2.5 | 65 | 42.0 | 6000 |
| UNC3/4-10X23/4 | 51 | 2 | -32 | UNC3/4-10 | 2-3/4 | 42.0 | 6000 |
| ZYLS24X75VZX | 64 | 2-1/2 | -40 | M24x3 | 75 | 42.0 | 6000 |
| - | 64 | 2-1/2 | -40 | - | - | 42.0 | 6000 |
| ZYLS30X90VZX | 76 | 3 | -48 | M30x3.5 | 90 | 42.0 | 6000 |
| - | 76 | 3 | -48 | - | - | 42.0 | 6000 |

- metric bolts according to ISO 4762-10.9 (DIN 912-10.9)

- UNC bolts according to ANSI / ASME B18.3

8FH – ISO 6162-2 Flange Half 8000 psi

(for use with 8A, 8F and 8N flanges)

| Part Number | | | |  G Thread metric <i>Inch</i> | A mm <i>Inch</i> |  max. dynamic working pressure | |
|---------------|----|-------|------|------------------------------------------------------------------------------------------------------------------------------|----------------------------|---------------------------------------------------------------------------------------------------------------------------|------|
| | DN | Inch | Size | | | MPa | psi |
| ZYLS10X45109X | 19 | 3/4 | -12 | M10x1.5 | 45 | 56.0 | 8000 |
| ZYLS12X50109X | 25 | 1 | -16 | M12x1.75 | 50 | 56.0 | 8000 |
| ZYLS12X50109X | 32 | 1-1/4 | -20 | M12x1.75 | 50 | 56.0 | 8000 |
| ZYLS14X50109X | 32 | 1-1/4 | -20 | M14x2 | 50 | 56.0 | 8000 |
| - | 51 | 2 | -32 | - | - | 34.5 | 5000 |

- metric bolts according to ISO 4762-10.9 (DIN 912-10.9)

- UNC bolts according to ANSI / ASME B18.3

Assembly torque see page **Ab-25**

Accessories

Full Flange System

Full Flange System



Provides full flange mounting option for ISO 6162-1 (35.0 MPa/5000 psi) and ISO 6162-2 (42.0 MPa/ 6000 psi) flanges – system flexibility reduces inventory investment.



Once the hose fitting is crimped to the hose, the flange is placed over the fitting end and then is held in place with the retaining ring. When the flange engages the retaining ring, the flange is held securely and is ready to be bolted to the port. Installation to the port is easy – there is no fumbling with the flange halves, and the flange can be rotated for ease of assembly to the port. The full flange system can be used repeatedly because of its patent-pending attachment system – the flange is not permanently locked onto the fitting.



Flange System

ISO 6162-1 (35.0 MPa/ 5000 psi)*

|  SAE Flange Size Inch |  max. dynamic working pressure | | Flange Part Number | Seal Part Number | Retaining Ring Part Number |
|----------------------------------------------------------------------------------------------------------------|-------------------------------------------------------------------------------------------------------------------------|------|-----------------------|---------------------|-------------------------------|
| | MPa | psi | | | |
| 3/4 | 35.0 | 5000 | R-312-CFX | 020119N0552 | R12X |
| 1 | 35.0 | 5000 | R-316-CFX | 020122N0552 | R16X |
| 1 1/4 | 35.0 | 5000 | R-320-CFX | 020126N0552 | R20X |
| 1 1/2 | 35.0 | 5000 | R-324-CFX | 020132N0552 | R24X |
| 2 | 35.0 | 5000 | R-332-CFX | 020139N0552 | R32X |
| 2 1/2 | 35.0 | 5000 | R-340-CFX | 020231N0552 | R40X |
| 3 | 21.0 | 3000 | R-348-CFX | 020235N0552 | R48X |

Flange System

ISO 6162-2 (42.0 MPa/ 6000 psi)*

|  SAE Flange Size Inch |  max. dynamic working pressure | | Flange Part Number | Seal Part Number | Retaining Ring Part Number |
|----------------------------------------------------------------------------------------------------------------|-------------------------------------------------------------------------------------------------------------------------|------|-----------------------|---------------------|-------------------------------|
| | MPa | psi | | | |
| 3/4 | 42.0 | 6000 | R-612-CFX | 020119N0552 | R12X |
| 1 | 42.0 | 6000 | R-616-CFX | 020122N0552 | R16X |
| 1 1/4 | 42.0 | 6000 | R-620-CFX | 020126N0552 | R20X |
| 1 1/2 | 42.0 | 6000 | R-624-CFX | 020132N0552 | R24X |
| 2 | 42.0 | 6000 | R-632-CFX | 020139N0552 | R32X |
| 2 1/2 | 35.0 | 5000 | R-640-CFX | 020231N0552 | R40X |
| 3 | 21.0 | 3000 | R-648-CFX | 020235N0552 | R48X |

* 2 1/2 inch max. 35.0 MPa/ 5000 psi
 3 inch max. 21.0 MPa/ 3000 psi

The stainless steel retaining rings and O-rings are recommended for one-time use.





Accessories

Bolts for Full Flange System

Bolts for Full Flange System ISO 6162

ISO 6162-1 Retaining Ring Flange System

(for use with X5, X7 and X9 flanges)





| Part Number |  Flange Part Number |  SAE Flange Size Inch |  G Thread metric Inch | A mm Inch |  max. dynamic working pressure | |
|-----------------|------------------------------------------------------------------------------------------------------------|--------------------------------------------------------------------------------------------------------------|--------------------------------------------------------------------------------------------------------------|--------------|-------------------------------------------------------------------------------------------------------------------------|------|
| | | | | | MPa | psi |
| ZYLS10X40VZX | R-312-CFX | 3/4 | M10x1.5 | 40 | 35.0 | 5000 |
| UNC3/8-16X11/4 | R-312-CFX | 3/4 | UNC3/8-16 | 1-1/4 | 35.0 | 5000 |
| ZYLS10X40VZX | R-316-CFX | 1 | M10x1.5 | 40 | 35.0 | 5000 |
| UNC3/8-16X11/4 | R-316-CFX | 1 | UNC3/8-16 | 1-1/4 | 35.0 | 5000 |
| ZYLS10X40VZX | R-320-CFX | 1-1/4 | M10x1.5 | 40 | 28.0 | 4000 |
| UNC7/16-14X11/2 | R-320-CFX | 1-1/4 | UNC7/16-14 | 1-1/2 | 28.0 | 4000 |
| ZYLS12X50VZX | R-324-CFX | 1-1/2 | M12x1.75 | 50 | 28.0 | 4000 |
| UNC1/2-13X11/2 | R-324-CFX | 1-1/2 | UNC1/2-13 | 1-1/2 | 28.0 | 4000 |
| ZYLS12X55VZX | R-332-CFX | 2 | M12x1.75 | 55 | 28.0 | 4000 |
| UNC1/2-13X11/2 | R-332-CFX | 2 | UNC1/2-13 | 1-1/2 | 28.0 | 4000 |
| ZYLS12X65VZX | R-340-CFX | 2-1/2 | M12x1.75 | 65 | 21.0 | 3000 |
| UNC1/2-13X13/4 | R-340-CFX | 2-1/2 | UNC1/2-13 | 1-3/4 | 21.0 | 3000 |
| ZYLS16X80VZX | R-348-CFX | 3 | M16x2 | 80 | 21.0 | 3000 |
| UNC5/8-11X13/4 | R-348-CFX | 3 | UNC5/8-11 | 1-3/4 | 21.0 | 3000 |

- metric bolts according to ISO 4762-10.9 (DIN 912-10.9)

- UNC bolts according to ANSI / ASME B18.3

ISO 6162-2 Retaining Ring Flange System

(for use with X5, X7 and X9 flanges)

| Part Number |  Flange Part Number |  SAE Flange Size Inch |  G Thread metric Inch | A mm Inch |  max. dynamic working pressure | |
|-----------------|--------------------------------------------------------------------------------------------------------------|----------------------------------------------------------------------------------------------------------------|----------------------------------------------------------------------------------------------------------------|--------------|---------------------------------------------------------------------------------------------------------------------------|------|
| | | | | | MPa | psi |
| ZYLS10X45VZX | R-612-CFX | 3/4 | M10x1.5 | 45 | 42.0 | 6000 |
| UNC3/8-16X11/2 | R-612-CFX | 3/4 | UNC3/8-16 | 1-1/2 | 42.0 | 6000 |
| ZYLS12X45VZX | R-616-CFX | 1 | M12x1.75 | 45 | 42.0 | 6000 |
| UNC7/16-14X11/2 | R-616-CFX | 1 | UNC7/16-14 | 1-1/2 | 42.0 | 6000 |
| ZYLS14X50VZX | R-620-CFX | 1-1/4 | M14x2 | 50 | 42.0 | 6000 |
| UNC1/2-13X13/4 | R-620-CFX | 1-1/4 | UNC1/2-13 | 1-3/4 | 42.0 | 6000 |
| ZYLS16X60VZX | R-624-CFX | 1-1/2 | M16x2 | 60 | 42.0 | 6000 |
| UNC5/8-11X21/4 | R-624-CFX | 1-1/2 | UNC5/8-11 | 2-1/4 | 42.0 | 6000 |
| ZYLS20X70VZX | R-632-CFX | 2 | M20x2.5 | 70 | 42.0 | 6000 |
| UNC3/4-10X23/4 | R-632-CFX | 2 | UNC3/4-10 | 2-3/4 | 42.0 | 6000 |
| ZYLS24X90VZX | R-640-CFX | 2-1/2 | M24x3 | 90 | 42.0 | 6000 |
| - | R-640-CFX | 2-1/2 | - | - | 42.0 | 6000 |
| ZYLS30X100VZX | R-648-CFX | 3 | M30x3.5 | 100 | 42.0 | 6000 |
| - | R-648-CFX | 3 | - | - | 42.0 | 6000 |

- metric bolts according to ISO 4762-10.9 (DIN 912-10.9)

- UNC bolts according to ANSI / ASME B18.3

Assembly torque see page **Ab-24, Ab-25**

Accessories

Banjo Bolt

Banjo Bolt

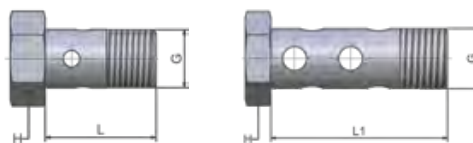

AM/AR – Banjo Bolt (DIN 7643)

| Single Part Number | Double Part Number | I.D. Banjo mm | G Thread metric Inch | L Single mm | L1 Double mm | H mm |
|-----------------------|-----------------------|---------------------|----------------------------|-------------------|--------------------|---------|
| AM-03 | A2M3 | 8 | M8x1 | 17 | 26 | 12 |
| AM-04 | A2M4 | 10 | M10x1 | 19 | 30 | 14 |
| AR-04 | | 10 | 1/8 | 19 | | 14 |
| AM-06 | A2M6 | 12 | M12x1.5 | 24 | 38 | 17 |
| AM-08 | A2M8 | 14 | M14x1.5 | 26 | 41 | 19 |
| AR-08 | | 14 | 1/4 | 26 | | 19 |
| AR-08C | | 14 | 1/4 | 26 | | 19 |
| AM-10 | A2M10 | 16 | M16x1.5 | 28 | 46 | 22 |
| AR-10 | | 17 | 3/8 | 29 | | 22 |
| AM-13 | | 18 | M18x1.5 | 32 | | 24 |
| AM-16 | | 22 | M22x1.5 | 39 | | 27 |
| AR-16 | | 22 | 1/2 | 39 | | 27 |
| AM-20 | | 26 | M26x1.5 | 45 | | 32 |
| AR-20 | | 27 | 3/4 | 45 | | 32 |

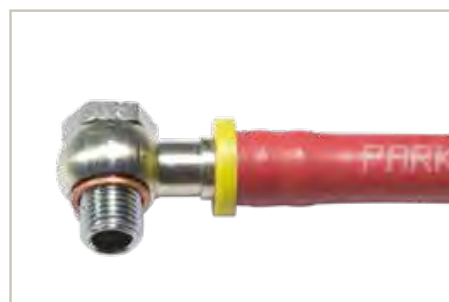

Complete banjo fitting

853009 – Copper Ring (Form A DIN 7603)

| Copper Ring Part Number | I.D. Banjo mm | G Thread metric Inch |
|----------------------------|---------------------|----------------------------|
| 853009-8 | 8 | M8x1 |
| 853009-10 | 10 | M10x1 |
| 853009-10 | 10 | 1/8 |
| 853009-12 | 12 | M12x1.5 |
| 853009-14 | 14 | M14x1.5 |
| 853009-14 | 14 | 1/4 |
| 853009-16 | 16 | M16x1.5 |
| 853009-17 | 17 | 3/8 |
| 853009-18 | 18 | M18x1.5 |
| 853009-21 | 21 | 1/2 |
| 853009-22 | 22 | M22x1.5 |
| 853009-26 | 26 | M26x1.5 |

Banjo fitting, bolt, double bolt, copper ring

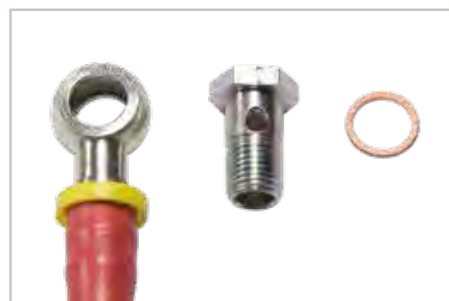

Accessories

O-Rings

O-Rings

Fittings are supplied with O-rings made from ozone-resistant Nitrile (NBR) rubber compound suitable for temperatures from -30 °C up to +105 °C and for ambient temperatures from -40 °C up to +120 °C

On request: Viton® (FPM) compound from -25 °C up to +200 °C
Ethylene-Propylene (EPDM) compound from -55 °C up to +150 °C

711509 – O-rings for SAE fittings (05 end configuration)

| O-Ring | | W | Thread UNF | Size |
|-------------|-------|------|------------|------|
| Part Number | mm | mm | UNF | |
| 711509-1 | 8.92 | 1.83 | 7/16x20 | -4 |
| 711509-2 | 10.52 | 1.83 | 1/2x20 | -5 |
| 711509-3 | 11.89 | 1.98 | 9/16x18 | -6 |
| 711509-4 | 16.36 | 2.21 | 3/4x16 | -8 |
| 711509-5 | 19.18 | 2.45 | 7/8x14 | -10 |
| 711509-6 | 23.47 | 2.95 | 1-1/16x12 | -12 |
| 711509-7 | 29.74 | 2.95 | 1-5/16x12 | -16 |
| 711509-8 | 37.47 | 3.00 | 1-5/8x12 | -20 |

2-0 – O-rings for ORFS male (JD and JM end configuration)

| O-Ring | | W | Thread UNF | Size |
|--------------|-------|------|------------|------|
| Part Number | mm | mm | UNF | |
| 2-011N552-90 | 7.65 | 1.78 | 9/16x18 | -4 |
| 2-012N552-90 | 9.25 | 1.78 | 11/16x16 | -6 |
| 2-014N552-90 | 12.42 | 1.78 | 13/16x16 | -8 |
| 2-016N552-90 | 15.60 | 1.78 | 1x14 | -10 |
| 2-018N552-90 | 18.77 | 1.78 | 1-3/16x12 | -12 |
| 2-021N552-90 | 23.52 | 1.78 | 1-7/16x12 | -16 |
| 2-025N552-90 | 29.87 | 1.78 | 1-11/16x12 | -20 |
| 2-029N552-90 | 37.82 | 1.78 | 2x12 | -24 |

EARG/VURG/VERG – O-rings for BSP fittings

| O-Ring | | W | Thread BSP | Size |
|-------------|------|-----|------------|------|
| Part Number | mm | mm | BSP | |
| EARG-4 | 6.0 | 1.0 | 1/4x19 | -4 |
| C9RG-10 | 8.5 | 1.5 | 3/8x19 | -6 |
| VURG-4 | 12.0 | 1.5 | 1/2x14 | -8 |
| EARG-10 | 13.1 | 1.6 | 5/8x14 | -10 |
| VERG-14 | 17.0 | 1.5 | 3/4x14 | -12 |
| VERG-19 | 21.0 | 1.5 | 1x11 | -16 |
| EARG-20 | 29.5 | 1.5 | 1-1/4x11 | -20 |



Accessories

O-Rings



O-Rings

O-rings for flange ISO 6162-1/-2



for flanges 15, 17, 19, 4A, 4F, 4N, 6A, 6F and 6N

| O-Ring |  |  |  | |
|-------------|-----------------------------------------------------------------------------------|-----------------------------------------------------------------------------------|-------------------------------------------------------------------------------------|------|
| Part Number | mm | mm | Inch | Size |
| 020210N0552 | 18.64 | 3.53 | 1/2 | -8 |
| 020214N0552 | 24.99 | 3.53 | 3/4 | -12 |
| 020219N0552 | 32.92 | 3.53 | 1 | -16 |
| 020222N0552 | 37.69 | 3.53 | 1 1/4 | -20 |
| 020225N0552 | 47.22 | 3.53 | 1 1/2 | -24 |
| 020228N0552 | 56.74 | 3.53 | 2 | -32 |
| 020232N0552 | 69.44 | 3.53 | 2 1/2 | -40 |
| 020237N0552 | 85.32 | 3.53 | 3 | -48 |
| 020241N0552 | 98.02 | 3.53 | 3 1/2 | -56 |
| 020245N0552 | 110.72 | 3.53 | 4 | -64 |
| 020253N0552 | 136.12 | 3.53 | 5 | -80 |

CARG – O-rings for metric 24° female swivel hose-end fittings

| O-Ring |  |  |  | | Tube O.D. mm |
|-------------|------------------------------------------------------------------------------------|------------------------------------------------------------------------------------|--------------------------------------------------------------------------------------|---------------------|--------------|
| Part Number | mm | mm | Light series metric | Heavy series metric | |
| CARG-6 | 4.5 | 1.5 | M12x1.5 | M14x1.5 | 6 |
| C9RG-8 | 6.5 | 1.5 | M14x1.5 | M16x1.5 | 8 |
| C9RG-10 | 8.5 | 1.5 | M16x1.5 | M18x1.5 | 10 |
| C9RG-12 | 10.5 | 1.5 | M18x1.5 | M20x1.5 | 12 |
| C9RG-14 | 12.0 | 2.0 | | M22x1.5 | 14 |
| CARG-15 | 12.5 | 2.0 | M22x1.5 | | 15 |
| C9RG-16 | 14.0 | 2.0 | | M24x1.5 | 16 |
| CARG-18 | 16.0 | 2.0 | M26x1.5 | | 18 |
| C9RG-20 | 17.0 | 2.5 | | M30x2 | 20 |
| CARG-22 | 20.0 | 2.0 | M30x2 | | 22 |
| C9RG-25 | 22.0 | 2.5 | | M36x2 | 25 |
| CARG-28 | 26.0 | 2.0 | M36x2 | | 28 |
| C9RG-30 | 27.0 | 2.5 | | M42x2 | 30 |
| CARG-35 | 32.0 | 2.5 | M45x2 | | 35 |
| C9RG-38 | 35.0 | 2.5 | | M52x2 | 38 |
| CARG-42 | 39.0 | 2.5 | M52x2 | | 42 |

XARG – Flange “D” rings Caterpillar® and 8000 psi style flanges

| O-Ring |  |  |  | |
|-------------|-------------------------------------------------------------------------------------|-------------------------------------------------------------------------------------|---------------------------------------------------------------------------------------|------|
| Part Number | mm | mm | Inch | Size |
| XARG-12 | 25.4 | 5.0 | 3/4 | -12 |
| XARG-16 | 31.9 | 5.0 | 1 | -16 |
| XARG-20 | 38.2 | 5.0 | 1 1/4 | -20 |
| XARG-24 | 44.7 | 5.0 | 1 1/2 | -24 |
| XARG-32 | 63.9 | 5.0 | 2 | -32 |

Accessories

Worm Drive Hose Clamps

Worm Drive Hose Clamps

With cross slotted hex head screw (DIN 3017) for all applications

- Bands and housings of AISI 300 series stainless steel
- Unique interlock construction locks directly into band which tightens under tension
- Shouldered hex head, slotted screw
No spot welds to rupture under stress or corrode
- Rounded band edges
- High efficiency giving high pressure sealing
- Wide clamping range, giving more flexibility to the user



Miniature Worm Drive Hose Clamps

These small, tough, precision-engineered hose clamps provide:

- Low profile
- Narrow housing
- No protrusions
- Highest sealing
- High working pressure at low torque
- Easy to install in confined areas

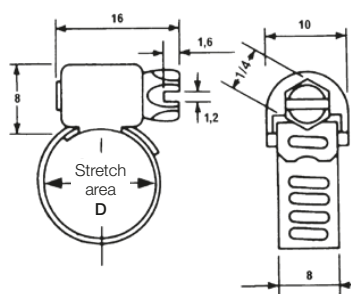

Band width 5/16" - 8 mm

Miniature Standard "M" Series

For all clamping applications meeting normal environmental conditions. Hex head screw made of zinc plated carbon steel.

Miniature Stainless "MS-N" Series

Preferred for those environmental conditions which require the extra protection provided by this 100% stainless steel hose clamp. Hex head screw of AISI 305 series made of stainless steel.

| "M" series Part Number | D Stretch area | | "MS" series Part Number |
|---------------------------|-------------------|-------------|----------------------------|
| | mm | Inch | |
| M 0200 | 6 - 16 | 0.25 - 0.62 | MS 0200 N |
| M 0300 | 8 - 22 | 0.30 - 0.87 | MS 0300 N |
| M 0400 | 16 - 32 | 0.66 - 1.25 | MS 0400 N |
| M 0500 | 16 - 38 | 0.66 - 1.50 | MS 0500 N |
| M 0600 | 19 - 45 | 0.66 - 1.75 | MS 0600 N |
| M 0700 | 25 - 50 | 1.00 - 2.00 | MS 0700 N |
| M 0800 | 35 - 60 | 1.38 - 2.38 | MS 0800 N |
| M 0900 | 45 - 70 | 1.75 - 2.75 | MS 0900 N |
| M 1000 | 58 - 82 | 2.25 - 3.25 | MS 1000 N |
| M 1100 | 64 - 90 | 2.50 - 3.50 | MS 1100 N |
| M 1200 | 77 - 100 | 3.00 - 4.00 | MS 1200 N |

For your safety

Hose clamps are intended to ensure the sealing of flexible hoses carrying fluids under pressure; we therefore recommend that you choose the appropriate hose clamp, adhere to the assembly torques indicated and correctly position the hose clamp onto the fitting. Any deformation of the hose requires tightening of the clamp. We disclaim all responsibility for any product failure that might ensue should these recommendations be ignored.



Accessories

Worm Drive Hose Clamps

Worm Drive Hose Clamps

With cross slotted hex head screw (DIN 3017) for all applications

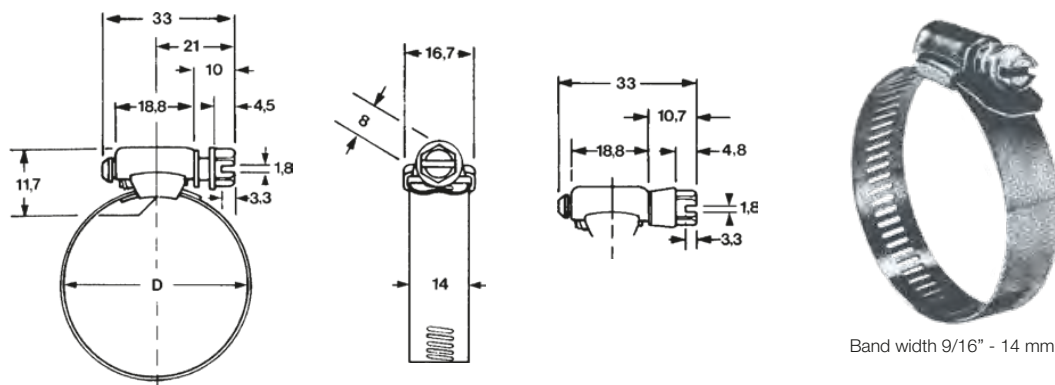

Standard "S" Series

Band and housing of stainless steel for all clamping applications, meeting normal environmental conditions. Hex head screw made of zinc plated carbon steel.

Stainless "SS-N" Series

Preferred for those environmental conditions which require the extra protection provided by this 100% stainless steel hose clamp. Hex head screw of AISI 305 series made of stainless steel.

| "S" series Part Number | "SS" series Part Number | D Stretch area | | |
|---------------------------|----------------------------|-------------------|-----------|-------------|
| | | size | mm | Inch |
| S0600 | SS0600N | -6 | 10 - 22 | 0.38 - 0.87 |
| S0800 | SS0800N | -8 | 11 - 25 | 0.44 - 1.00 |
| S1000 | SS1000N | -10 | 13 - 27 | 0.50 - 1.06 |
| S1200 | SS1200N | -12 | 13 - 32 | 0.50 - 1.25 |
| S1600 | SS1600N | -16 | 19 - 38 | 0.75 - 1.50 |
| S2000 | SS2000N | -20 | 19 - 44 | 0.75 - 1.75 |
| S2400 | SS2400N | -24 | 26 - 50 | 1.00 - 2.00 |
| S2800 | SS2800N | -28 | 34 - 57 | 1.32 - 2.25 |
| S3200 | SS3200N | -32 | 40 - 64 | 1.57 - 2.50 |
| S3600 | SS3600N | -36 | 23 - 70 | 0.88 - 2.75 |
| S4000 | SS4000N | -40 | 29 - 76 | 1.13 - 3.00 |
| S4400 | SS4400N | -44 | 34 - 82 | 1.32 - 3.25 |
| S4800 | SS4800N | -48 | 42 - 90 | 1.63 - 3.50 |
| S5200 | SS5200N | -52 | 48 - 95 | 1.88 - 3.75 |
| S5600 | SS5600N | -56 | 54 - 100 | 2.13 - 4.00 |
| S6400 | SS6400N | -64 | 67 - 114 | 2.63 - 4.50 |
| S7200 | SS7200N | -72 | 76 - 127 | 3.00 - 5.00 |
| S8000 | SS8000N | -80 | 92 - 140 | 3.63 - 5.50 |
| S8800 | SS8800N | -88 | 108 - 152 | 4.25 - 6.00 |
| S9600 | SS9600N | -96 | 120 - 165 | 4.74 - 6.50 |
| S1040 | SS1040N | -104 | 129 - 178 | 5.06 - 7.00 |

Numerous applications in all fields

Automobile industry, ship building, automation systems, agricultural machinery, packaging machines, machine tools, mechanical handling equipment, welding equipment, construction equipment, petrochemical industry, mining, metallurgy.



Accessories

Hose Protection

Protected hose assemblies live longer

In places where the hose assembly is exposed to severe mechanical strain, additional hose protectors such as guards, sleeves etc. have proven to be a good solution. The spring guards or armor guards, for example, prevent kinking of the hose and are the ideal protection against extreme abrasion or possible damage from the outside. Before the fitting is crimped to the hose, the guard needs to be pushed onto the hose – so please remember to order the guards together with your order of hose assembly components.

For some applications it is an advantage to bundle hose assemblies with plastic hose protector coils or sleeves so that they make compact units. For this purpose we recommend using PolyGuard protectors, ParKoil hose protectors and Partek Wraps. Partek Wraps hose sleeves are designed for bundling hose assemblies after installation.

Parker offers a broad range of accessories to work smarter, faster and better!

Spring Guard & Armour Guard (SG & AG)

Parker spring guard and armour guard are two products that prolong the life of your hose lines that are exposed to rugged operating conditions. They distribute bending radii to avoid kinking in hose lines and protect hose from abrasion and deep cuts. Guards are constructed of steel wire and plated to resist rust. See page **Eb-12** and **Eb-13**

PolyGuard & Parkoil (HG & PG)

Protect and bundle your hoses with these spiral guards that minimize kinking and cannot rust. Both the PolyGuard and Parkoil install without removing the hose. See page **Eb-18** and **Eb-19**

Partek (AS & PS)

Nylon woven protective sleeving gives you tough hose abrasion resistance with two versions of coverage – standard “AS” and a lighter “PS” – both providing protection and bundling capability. See page **Eb-14** and **Eb-15**

Minesleeve (DMS)

Best abrasion resistance without adding stiffness to hose assemblies and exceeds the MSHA specifications for flame resistance and flame propagation. See page **Eb-16**

Firesleeve (FS-F)

A flame-resistant sheath that protects your hose from extremely high temperature conditions. See page **Eb-17**

Partek Wrap (PS-BV)

The need for a protective hose sleeve is not always considered while designing for a hose's application. Many hose assembly installations would benefit from a sleeve, but it is not obvious until all the other hoses and components are in place. Partek Wrap enables the hose sleeve to be installed after the hose assemblies have been positioned and secured in place. The Partek Wrap can be used as extra abrasion protection or to wrap multiple hoses or cables together. See page **Eb-20**

Hose Shields (HP-B)

Hose protection shields extend hose life by protecting the hose from abrasion that occurs when hose rubs against other hose, metal or concrete. Parker hose shields are resistant to oil, lubricants, gasoline, most solvents and can withstand ambient temperatures from -40 °C to +150 °C. Easily installed and secured by cable ties without disconnecting any hose lines. See page **Eb-21**



SG – Spring Guard

Spring Guards protect the hose cover against abrasion and are constructed of steel wire and plated to resist rust.



| Hose I.D. Part mm Number | SG-060 | SG-066 | SG-072 | SG-084 | SG-097 | SG-106 | SG-113 | SG-122 | SG-131 | SG-155 | SG-166 | SG-182 | SG-209 | SG-220 | SG-232 | SG-270 |
|---------------------------------------------------------------------------------------------------------------------------|-------------|--------|--------|--------|--------|--------|--------|--------|--------|--------|--------|--------|--------|--------|--------|--------|
| 201, 206, 221FR, 244 | -4 | -5 | -6 | -8 | -10 | | -12 | | -16 | -20 | | -24 | | | -32 | |
| 213, 285, 293 | -4/-5 | -6 | | -8 | -10 | -12 | | | -16 | -20 | | -24 | | -32 | | |
| 301SN, 304 | | -4 | -5 | -6 | -8 | -10 | | -12 | | -16 | | | -20 | | -24 | |
| 421RH, 421SN, 421TC, 426, 436, 441, 441RH, 461LT, 462, 462TC, 462ST, 462PU, 463, 471TC, 493, 611HT, 681, 681DB, BCH2, HT2 | -4 | -5 | -6 | -8 | -10 | | -12 | | | -16 | | -20 | -24 | | | -32 |
| 492, 492TC, 492ST, BCH1, 692, 692PU, 692TC | -4/-5 | -6 | | -8 | -10 | | -12 | | | -16 | -20 | | | | | |
| 372, 372RH, 372TC, 371LT, 701, 701TC | | | | | -6 | -8 | | -10 | -12 | | -16 | | -20 | | -24 | |
| 774, F42 | | | | | | -8 | | | -12 | -16 | | | -20 | -24 | | -32 |
| 731, 731TC | | | | | | | | | -12 | | -16 | | -20 | | -24 | |
| 801PLUS, 801RH, 804, 821FR, 830M, 836, 837BM, 837PU, 838M, 846 | -4/-5 | -6 | | -8 | -10 | | -12 | | -16 | | | | | | | |
| 811, 881, H29, H29ST, H29TC | | | | | | | | | -12 | -16 | | -20 | | -24 | | -32 |
| H31, H31ST, H31TC | | | -4 | | -6 | -8 | | -10 | -12 | | -16 | | | | | |
| R35, R35TC | | | | | | | | | -12 | | -16 | -20 | | | -24 | |
| R42, R42ST, R42TC | | | | | | | | -10 | -12 | | -16 | | -20 | | -24 | |
| R50TC, R56TC | | | -4 | | -6 | -8 | | -10 | -12 | -16 | | | -20 | | | |
| 787, 787TC, 787ST, 797, 797TC, 797ST, 797RH | -4 | | -6 | | -8 | -10 | | -12 | | -16 | | -20 | | -24 | | -32 |
| 722, 722TC, 722ST | | | | -6 | -8 | | -10 | | -12 | -16 | | | | | | |
| 412, 412ST | -4/-5 -6 | | | | | | | | | | | | | | | |
| 477, 477RH, 477TC, 477ST, 387, 387TC, 387ST, 487, 487TC, 487ST | -4 | -5 | -6 | -8 | -10 | | -12 | | | -16 | | | -20 | -24 | | -32 |
| SX35, SX35LT, SX35TC, SX42, SX42LT, SX42TC | | | | | | | | | -12 | -16 | | | -20 | | | |
| BPK | | | | | -6 | -8 | | | | -12 | | -16 | | | | |
| FA35 | | | | | -6 | -8 | | -10 | -12 | | -16 | | -20 | | | -24 |

AG – Armour Guard

For extreme abrasion or possible damage from the outside, the corrosion-protected steel flat coil sleeve is recommended.



| Hose \ I.D. Part Number | AG-060 | AG-066 | AG-072 | AG-084 | AG-097 | AG-106 | AG-113 | AG-122 | AG-131 | AG-155 | AG-161 | AG-166 | AG-182 | AG-209 | AG-232 | AG-270 | AG-292 | AG-319 |
|-----------------------------------------------------------------------------------------------------|--------|--------|--------|--------|--------|--------|--------|--------|--------|--------|--------|--------|--------|--------|--------|--------|--------|--------|
| I.D. mm | 15.20 | 16.75 | 18.25 | 21.30 | 24.60 | 26.90 | 28.70 | 30.95 | 33.25 | 39.35 | 40.85 | 42.15 | 46.20 | 53.05 | 58.90 | 68.55 | 74.20 | 81.00 |
| 201, 206, 221FR | -4 | -5 | -6 | -8 | -10 | | -12 | | -16 | -20 | | | -24 | | -32 | | -40 | |
| 213, 285, 293 | -4/-5 | -6 | | -8 | -10 | -12 | | | -16 | -20 | | | -24 | | | | -40 | |
| 301SN, 304 | | -4 | -5 | -6 | -8 | -10 | | -12 | | -16 | | | | -20 | -24 | | -32 | |
| 421RH, 421SN, 426, 436, 441, 441RH, 461LT, 462, 462TC, 463, 471TC, 492, 493, 611HT, 681, 681DB, 692 | -4 | -5 | -6 | -8 | -10 | | -12 | | | -16 | | | -20 | -24 | | -32 | | -40 |
| 372, 372RH, 371LT, 701 | | | | | -6 | -8 | | -10 | -12 | -16 | | | | -20 | -24 | | | |
| 774 | | | | -6 | -8 | | -10 | -12 | -16 | | | | | -20 | | -32 | | |
| 731 | | | | | | | | | -12 | | | -16 | -20 | -24 | | | -32 | |
| 801PLUS, 801RH, 804, 821FR, 836, 837BM | -4/-5 | | -6 | -8 | -10 | | -12 | | -16 | | | | | | | | | |
| 811, 881, H29, H29ST, H29TC | | | | | | | | | -12 | -16 | | | -20 | | | -32 | | -40 |
| H31, H31ST, H31TC | | | -4 | | -6 | -8 | | -10 | -12 | | -16 | | | | | | | |
| R35, R35TC | | | | | | | | | -12 | | -16 | | -20 | | -24 | | -32 | |
| R42, R42ST, R42TC | | | | | | | | -10 | -12 | | -16 | | | -20 | -24 | | -32 | |
| R50TC / R56TC | | | | | -6 | -8 | | -10 | -12 | | -16 | | | -20 | | | | |
| 787TC, 797TC | | | -6 | -8 | | -10 | | -12 | | -16 | | | -20 | | -24 | -32 | | |
| 412 | -4/-6 | | | | | | | | | | | | | | | | | |
| 477 | -4 | -5 | -6 | -8 | | -10 | | | -12 | -16 | | | | | | | | |

Accessories

Hose Protection

Partek® Nylon Protective Sleeve

AS – Partek® Nylon Protective Sleeve

Parker's Partek Nylon Protective Sleeving gives you tough hose abrasion protection two ways.

First, per the ISO 6945 specification, Partek has a unique tubular weave nylon construction,

Partek "AS" is strong enough to withstand greater than 200,000 abrasion cycles without wearing through the fabric at any location.

In addition, this weave also gives an exceptionally smooth interior wall, allowing rubber hose to move freely inside the sleeve. This provides easy installation and prevents any internal abrasion problems. Partek sleeving is available in either black or yellow and in sizes to fit most hydraulic hose. Partek, the quick and easy solution to hose protection in high-abrasion areas.



Temperature Range -55 °C up to +120 °C

| Part Number | | I.D. round | | I.D. flat | |
|-------------|---------|------------|------|-----------|------|
| | | mm | Inch | mm | Inch |
| black | yellow | | | | |
| AS-B-11 | AS-Y-11 | 19 | 0.75 | 27 | 1.07 |
| AS-B-13 | AS-Y-13 | 24 | 0.93 | 34 | 1.34 |
| AS-B-15 | AS-Y-15 | 29 | 1.13 | 42 | 1.66 |
| AS-B-17 | AS-Y-17 | 31 | 1.22 | 46 | 1.82 |
| AS-B-19 | AS-Y-19 | 34 | 1.35 | 51 | 2.02 |
| AS-B-22 | AS-Y-22 | 36 | 1.43 | 54 | 2.13 |
| AS-B-27 | AS-Y-27 | 41 | 1.63 | 62 | 2.45 |
| AS-B-33 | AS-Y-33 | 46 | 1.81 | 70 | 2.75 |
| AS-B-35 | AS-Y-35 | 56 | 2.19 | 85 | 3.33 |
| AS-B-37 | AS-Y-37 | 60 | 2.38 | 92 | 3.63 |
| AS-B-39 | AS-Y-39 | 67 | 2.63 | 102 | 4.02 |
| AS-B-45 | AS-Y-45 | 73 | 2.88 | 113 | 4.43 |
| AS-B-47 | AS-Y-47 | 80 | 3.13 | 122 | 4.80 |
| AS-B-53 | AS-Y-53 | 86 | 3.38 | 132 | 5.20 |
| AS-B-58 | AS-Y-58 | 92 | 3.63 | 142 | 5.59 |
| AS-B-64 | AS-Y-64 | 102 | 4.00 | 157 | 6.18 |

PS – Partek® Nylon Protective Sleeve

Parker's Partek Nylon Protective Sleeving gives you tough hose abrasion protection two ways. First, per the ISO 6945 specification, Partek has a unique tubular weave nylon construction, Partek "PS" is strong enough to withstand greater than 50,000 abrasion cycles without wearing through the fabric at any location. In addition, this weave also gives an exceptionally smooth interior wall, allowing rubber hose to move freely inside the sleeve. This provides easy installation and prevents any internal abrasion problems. Partek sleeving is available in either black or yellow and in sizes to fit most hydraulic hose. Partek, the quick and easy solution to hose protection in high-abrasion areas.



Temperature Range -55 °C up to +120 °C

| Part Number | I.D. round | | I.D. flat | |
|-------------|------------|------|-----------|------|
| | mm | Inch | mm | Inch |
| PS-B-12 | 19 | 0.75 | 27 | 1.08 |
| PS-B-13 | 23 | 0.91 | 34 | 1.32 |
| PS-B-15 | 27 | 1.06 | 40 | 1.56 |
| PS-B-17 | 31 | 1.22 | 46 | 1.82 |
| PS-B-22 | 36 | 1.42 | 54 | 2.14 |
| PS-B-33 | 46 | 1.81 | 70 | 2.75 |
| PS-B-35 | 56 | 2.19 | 85 | 3.33 |
| PS-B-37 | 60 | 2.38 | 92 | 3.63 |
| PS-B-39 | 67 | 2.63 | 102 | 4.02 |
| PS-B-45 | 73 | 2.88 | 113 | 4.43 |
| PS-B-47 | 80 | 3.13 | 122 | 4.8 |
| PS-B-80 | 127 | 5.00 | 197 | 7.75 |
| PS-B-88 | 140 | 5.50 | 217 | 8.54 |

Accessories

Hose Protection

Minesleeve

DMS – Minesleeve

Parker Minesleeve offers the best abrasion resistance without adding stiffness to hose assemblies and exceeds the MSHA specifications for flame resistance and flame propagation. Burst tests performed according to SAE J343 on hose assemblies covered with Minesleeve (DMS) show an oil spill retention capability of 7 times greater than similar products. Also suitable for bundling small hose assemblies, tubing or wires.



- Abrasion resistance
 - offers the best abrasion resistance without adding stiffness to hose assemblies
- Fire & flame resistance
 - exceeds US MSHA specifications for flame resistance & flame propagation
- Electrical conductivity
 - tests performed to ISO 8031 on hose assemblies covered with minesleeve show electrical conductivity values well below the specification requirements
- Oil spill retention
 - burst tests performed according to SAE J343 on hose assemblies covered with minesleeve show an oil spill retention capability of 7 times greater than similar products, also suitable for bundling small hose assemblies, tubing or wires. DMS complies with the requirements from: ISO 4413, ISO 3457, DIN ISO 201, DGUV 113-020 and others.
- MSHA approved

Temperature Range -50 °C up to +120 °C

| Part Number | I.D. round | | I.D. flat | |
|-------------|------------|------|-----------|------|
| | mm | Inch | mm | Inch |
| DMS-23 | 23 | 0.91 | 39 | 1.54 |
| DMS-27 | 27 | 1.06 | 45 | 1.77 |
| DMS-31 | 31 | 1.22 | 52 | 2.05 |
| DMS-36 | 36 | 1.42 | 57 | 2.24 |
| DMS-47 | 47 | 1.85 | 77 | 3.03 |
| DMS-55 | 55 | 2.17 | 89 | 3.5 |
| DMS-66 | 66 | 2.60 | 107 | 4.21 |
| DMS-85 | 85 | 3.35 | 136 | 5.35 |
| DMS-93 | 93 | 3.66 | 149 | 5.87 |
| DMS-127 | 127 | 5.00 | 197 | 7.75 |

FS-F – Fire Sleeves

Parker Firesleeve is a flame resistant sheath that protects the hose from extreme temperature conditions. Firesleeve easily slides over hoses and readily expands over fitting. When fitting the fire sleeve to hose assemblies with reusable or crimped fittings, a fire sleeve clamp must be used.



- Braided fiberglass sleeve with orange, bonded and seamless silicone rubber cover

- Conforms to SAE Aerospace Standard 1072A Type 2A

Temperature Range -54 °C up to +260 °C

- Certification:
 - UL 1441 Certified
 - VW1 Flame Test Certified
 - MSHA Certified for use in underground mines
 - SAE AS1072E
 - DNV-GL Certified to 800C/30 mins (ISO15540 & ISO15541)
 - BS EN 373 Molten Splash Tested
 - BS EN 388 Abrasion Tested
 - BS EN ISO 6940 Flame Resistance Tested
 - BS EN ISO 6530 Oil Resistance Tested
 - BS 2576 Tensile Strength Tested
 - MIL-C-24576A
 - PJA and P96 Thermal Conductivity

| Part Number | min. I.D. | | max. O.D. | | Suction Hose (R4) | | | 1-/2-Wire Braided | | | Multispiral | | |
|-------------|-----------|------|-----------|------|-------------------|----------|------------|-------------------|----------|------------|----------------|----------|------------|
| | mm | Inch | mm | Inch | inch | mm | size | inch | mm | size | inch | mm | size |
| FS-F-10 | 15 | 0.58 | 25 | 0.97 | | | | 1/4 | 6 | -4 | | | |
| FS-F-11 | 17 | 0.65 | 26 | 1.03 | | | | 1/4 5/16 | 6 8 | -4 -5 | | | |
| FS-F-12 | 18 | 0.71 | 28 | 1.09 | | | | 5/16 | 8 | -5 | | | |
| FS-F-14 | 21 | 0.84 | 31 | 1.22 | | | | 3/8 | 10 | -6 | | | |
| FS-F-16 | 24 | 0.96 | 35 | 1.38 | | | | 1/2 | 13 | -8 | 1/4 3/8 | 6 10 | -4 -6 |
| FS-F-18 | 27 | 1.08 | 38 | 1.50 | | | | 1/2 5/8 | 13 16 | -8 -10 | 1/2 | 13 | -8 |
| FS-F-20 | 31 | 1.21 | 40 | 1.59 | | | | 3/4 | 19 | -12 | 1/2 5/8 | 13 16 | -8 -10 |
| FS-F-22 | 34 | 1.34 | 44 | 1.75 | 3/4 | 19 | -12 | | | | 3/4 | 19 | -12 |
| FS-F-24 | 37 | 1.46 | 48 | 1.90 | | | | 1 | 25 | -16 | | | |
| FS-F-28 | 43 | 1.71 | 52 | 2.06 | 1 | 25 | -16 | 1 | 25 | -16 | 1 | 25 | -16 |
| FS-F-30 | 47 | 1.84 | 56 | 2.19 | | | | | | | | | |
| FS-F-32 | 50 | 1.96 | 59 | 2.32 | 1 1/4 | 32 | -20 | 1 1/4 | 32 | -20 | | | |
| FS-F-38 | 59 | 2.34 | 70 | 2.74 | | | -24 | 1 1/4 1 1/2 | 32 38 | -20 -24 | 1 1/4 1 1/2 | 32 38 | -20 -24 |
| FS-F-40 | 63 | 2.46 | 71 | 2.79 | | | | | | | 1 1/2 | 38 | -24 |
| FS-F-48 | 75 | 2.96 | 86 | 3.40 | 2 | 51 | -32 | 2 | 51 | -32 | 2 | 51 | -32 |
| FS-F-60 | 94 | 3.71 | 105 | 4.15 | 2 1/2 3 | 65 76 | -40 -48 | 2 1/2 3 | 65 76 | -40 -48 | 2 1/2 | 65 | -40 |
| FS-F-64 | 102 | 4.10 | 114 | 4.50 | | | | | | | 3 | 76 | 48 |
| FS-F-72 | 114 | 4.60 | 126 | 5.00 | 3 1/2 | 90 | 56 | | | | | | |
| FS-F-80 | 127 | 5.00 | 139 | 5.50 | 4 | 102 | 64 | | | | | | |

Accessories



HG – PolyGuard Hose Protector

Heavy duty polyethylene provides protection in rugged operating conditions, great for bundling high-pressure hose lines



- Shields hose from abrasion and cuts
- Easy to install without removing hose lines: no clamps needed
- Minimises risk of kinking
- Resistant to air, water, oil, gasoline, hydraulic fluid and most solvents
- Ideal for bundling plastic tubing or hose lines
- Cannot rust or corrode
- Color: black

Caution: This material will support combustion

Temperature Range -40 °C up to +93 °C

| Part Number | min. I.D. | | 1-/2-wire braided | | | Multispiral | | | Suction hose (R4) | | |
|-------------|--------------|-------------|---------------------|----------------|-------------------|---------------------|----------------|-------------------|---------------------|----------------|-------------------|
| | mm | Inch | Inch | mm | Size | Inch | mm | Size | Inch | mm | Size |
| HG-075 | 18.3 - 19.8 | 0.72 - 0.78 | 1/2 5/8 | 13 16 | -8 -10 | 1/4 3/8 | 6 10 | -4 -6 | - | - | - |
| HG-100 | 24.6 - 26.2 | 0.97 - 1.03 | 3/4 | 19 | -12 | 1/2 5/8 | 13 16 | -8 -10 | 3/4 | 19 | -12 |
| HG-125 | 31.0 - 32.5 | 1.22 - 1.28 | 1 | 25 | -16 | 3/4 | 19 | -12 | - | - | - |
| HG-150 | 37.30 - 38.9 | 1.47 - 1.53 | 1 1/4 | 32 | -20 | 1 | 25 | -16 | 1 1 1/4 | 25 32 | -16 -20 |
| HG-200 | 50.0 - 51.6 | 1.97 - 2.03 | 1 1/2 2 2 1/2 | 32 38 51 | -24 -32 -40 | 1 1/4 1 1/2 2 | 32 38 51 | -20 -24 -32 | 1 1/2 2 2 1/2 | 32 38 51 | -24 -32 -40 |
| HG-350 | 88.1 - 89.7 | 3.47 - 3.53 | 3 | 76 | -48 | 2 1/2 3 | 65 76 | -40 -48 | 3 | 76 | -48 |

PG – ParKoil Hose Protector

Lower-cost protection for applications that call for a tighter bend radius and are less demanding



- Shields hose from abrasion and cuts
- Easy to install without removing hose lines: no clamps needed
- Minimises risk of kinking
- Resistant to air, water, oil, gasoline, hydraulic fluid and most solvents
- Ideal for bundling plastic tubing or hose lines
- Cannot rust or corrode
- Color: black

Caution: This material will support combustion

Temperature Range -17 °C up to +93 °C

| Part Number | min. I.D. | | 1-/2-wire braided | | | Multispiral | | | Suction hose (R4) | | |
|-------------|-------------|---------------|-------------------|----------|------------|-------------|----------|------------|-------------------|----------|------------|
| | mm (± 1.25) | Inch (± 0.05) | Inch | mm | Size | Inch | mm | Size | Inch | mm | Size |
| PG-038 | 9.65 | 0.38 | 3/16 | 5 | -3 | - | - | - | - | - | - |
| PG-050 | 12.70 | 0.50 | 1/4 5/16 | 6 8 | -4 -5 | - | - | - | - | - | - |
| PG-062 | 15.75 | 0.62 | 3/8 | 10 | -6 | 1/4 | 6 | -4 | - | - | - |
| PG-075 | 19.05 | 0.75 | 1/2 | 13 | -8 | 3/8 | 10 | -6 | - | - | - |
| PG-088 | 22.35 | 0.88 | 5/8 | 16 | -10 | 1/2 | 13 | -8 | - | - | - |
| PG-100 | 25.40 | 1.00 | 3/4 | 19 | -12 | 5/8 | 16 | -10 | - | - | - |
| PG-119 | 30.25 | 1.19 | - | - | - | 3/4 | 19 | -12 | 3/4 | 19 | -12 |
| PG-138 | 35.05 | 1.38 | 1 1 1/4 | 25 32 | -16 -20 | 1 1 1/4 | 25 32 | -16 -20 | 1 | 25 | -16 |
| PG-188 | 47.75 | 1.88 | 1 1/2 2 | 38 51 | -24 -32 | 1 1/2 2 | 38 51 | -24 -32 | 1 1/2 2 | 38 51 | -24 -32 |

Accessories

Accessories

Hose Protection

Partek Wrap / Rubber Hand Grip

PS – Partek Wrap

Nylon hose sleeve designed for bundling hose assemblies after installation

- Post-assembly installation
- Light weight and high flexibility
- Urethane-coated 1050 ballistic Nylon
- Ambient temperature range of -51 °C to 93 °C
- Fast and easy installation
- Designed for added abrasion resistance or bundling of multiple hoses
- Can be cut to size with household scissors



| Part Number | I.D. round | | I.D. flat | |
|-------------|------------|------|-----------|------|
| | mm | Inch | mm | Inch |
| PS-BV-200 | 50 | 2 | 80 | 3.2 |
| PS-BV-300 | 75 | 3 | 80 | 3.2 |
| PS-BV-400 | 100 | 4 | 162 | 6.5 |
| PS-BV-500 | 125 | 5 | 203 | 8.1 |
| PS-BV-600 | 150 | 6 | 243 | 9.7 |
| PS-BV-700 | 175 | 7 | 283 | 11.3 |
| PS-BV-800 | 200 | 8 | 325 | 13.0 |

WKS Rubber hand grip

For *No-Skive* high pressure water cleaning hoses

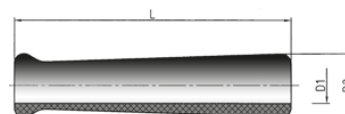

| Hand Grip | | Hose I.D. | | | | L mm | D1 mm | D2 mm |
|-------------|--------|-----------|------|------|------|---------|----------|----------|
| Part Number | Colour | DN | Inch | Size | mm | | | |
| WKS-4-BLK | black | 6 | 1/4 | -4 | 6.4 | 120 | 15.0 | 24 |
| WKS-4-BLU | blue | 6 | 1/4 | -4 | 6.4 | 120 | 15.0 | 24 |
| WKS-5-BLK | black | 8 | 5/16 | -5 | 7.9 | 150 | 17.0 | 34 |
| WKS-5-BLU | blue | 8 | 5/16 | -5 | 7.9 | 150 | 17.0 | 34 |
| WKS-6-BLK | black | 10 | 3/8 | -6 | 9.5 | 150 | 19.5 | 34 |
| WKS-6-BLU | blue | 10 | 3/8 | -6 | 9.5 | 150 | 19.5 | 34 |
| WKS-8-BLK | black | 12 | 1/2 | -8 | 12.7 | 150 | 22.5 | 34 |
| WKS-8-BLU | blue | 12 | 1/2 | -8 | 12.7 | 150 | 22.5 | 34 |
| WKS-8-GRA | grey | 12 | 1/2 | -8 | 12.7 | 150 | 22.5 | 34 |



Eb-20

Catalogue 4400/UK

Accessories

Hose Protection

Hose Shield

HP-B – Hose Shield

Hose protection shields extend hose life by protecting the hose from abrasion that occurs when hose rubs against other hose, metal or concrete. Parker hose shields are resistant to oil, lubricants, gasoline, most solvents and can withstand ambient temperatures from -40 °C to +150 °C. Easily installed and secured by cable ties without disconnecting any hose lines.



- Use with hose from size -4 up to size -32
- Eliminate hose abrasion on concrete, metal or any rough surface
- Guard against hose deterioration on mobile hydraulic equipment
- Let Parker fill all your hydraulic and pneumatic hose product needs

| | | |
|------------------------------------------------------------------------------------------------------------------------------------------------------------------------------------------------------------------------------------------------------------------------------------------------|--------------------|-----------------------|
| Hose Shields KIT HP-B-13X18-KIT with – 2 x HP-13 RFL Hose Protectors, length 101 mm (4") – 2 x HP-15 RFL Hose Protectors, length 152 mm (6") – 4 x HP-18 RFL Hose Protectors, length 203 mm (8") – 30 x HT-12 Tie Wraps – 30 x HT-16 Tie Wraps – 15 x HT-22 Tie Wraps | Part Number | HP-B-13X18-KIT |
| Counter Display HP-B-13-RFL with – 10 x HP-B-13 Hose Protectors, length 101 mm (4") – 30 x HT-12 Tie Wraps | Part Number | HP-B-13-RFL |
| Counter Display HP-B-15-RFL with – 10 x HP-B-15 Hose Protectors, length 152 mm (6") – 30 x HT-16 Tie Wraps | Part Number | HP-B-15-RFL |
| Counter Display HP-B-18-RFL with – 5 x HP-B-18 Hose Protectors, length 203 mm (8") – 15 x HT-18 Tie Wraps | Part Number | HP-B-18-RFL |
| Hose Protector , length 101 mm (4") | Part Number | HP-B-13 |
| Hose Protector , length 152 mm (6") | Part Number | HP-B-15 |
| Hose Protector , length 203 mm (8") | Part Number | HP-B-18 |

Accessories

Hose Whip Restraint

Hose collars/ Cable Assemblies

Hose Whip Restraint

Safety Restraining System for Pressure Hoses

- Prevents whipping of a pressurized hose in the event of the hose separating from its fitting
- The system consists of two parts
 - a hose collar and a cable assembly



| Part Number | A | | B | |
|-------------|------|----|-------|------|
| | Inch | mm | Inch | mm |
| WRC1212 | 0.47 | 12 | 0.492 | 12.5 |
| WRC1313 | 0.51 | 13 | 0.531 | 13.5 |
| WRC1415 | 0.55 | 14 | 0.591 | 15 |
| WRC1718 | 0.67 | 17 | 0.709 | 18 |
| WRC1819 | 0.71 | 18 | 0.748 | 19 |
| WRC2021 | 0.79 | 20 | 0.827 | 21 |
| WRC2223 | 0.87 | 22 | 0.906 | 23 |
| WRC2425 | 0.95 | 24 | 0.984 | 25 |
| WRC2526 | 0.98 | 25 | 1.024 | 26 |
| WRC2728 | 1.06 | 27 | 1.102 | 28 |
| WRC2829 | 1.10 | 28 | 1.142 | 29 |
| WRC3031 | 1.18 | 30 | 1.220 | 31 |
| WRC3435 | 1.34 | 34 | 1.378 | 35 |
| WRC3637 | 1.42 | 36 | 1.457 | 37 |
| WRC3839 | 1.50 | 38 | 1.535 | 39 |
| WRC4445 | 1.73 | 44 | 1.772 | 45 |
| WRC4547 | 1.77 | 45 | 1.850 | 47 |
| WRC4850 | 1.89 | 48 | 1.969 | 50 |
| WRC5153 | 2.01 | 51 | 2.087 | 53 |
| WRC5456 | 2.13 | 54 | 2.205 | 56 |
| WRC5759 | 2.25 | 57 | 2.330 | 59 |
| WRC6365 | 2.48 | 63 | 2.559 | 65 |
| WRC6971 | 2.72 | 69 | 2.795 | 71 |
| WRC7577 | 3.00 | 75 | 3.030 | 77 |
| WRC8486 | 3.30 | 84 | 3.380 | 86 |
| WRC8789 | 3.42 | 87 | 3.500 | 89 |

Hose collars

for Hose Whip Restraint System

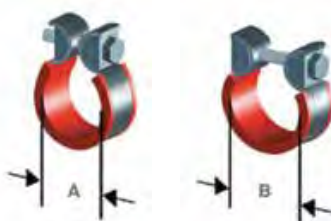

Cable Assemblies

for hoses attached with port adapters



Cable Assemblies

for hoses using flange-style connections
ISO 6162-1 (35.0 MPa/5000 psi) and
ISO 6162-2 (42.0 MPa/ 6000 psi)

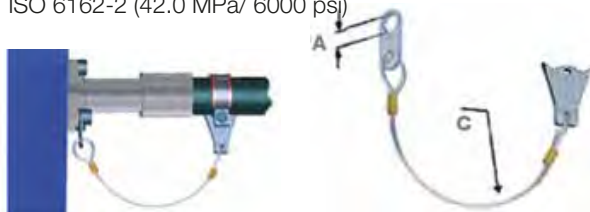

| Part Number | A | | C | |
|-------------|------|------|-------|-----|
| | Inch | mm | Inch | mm |
| WRF085 | 0.33 | 8.5 | 11.81 | 300 |
| WRF105 | 0.41 | 10.5 | 17.72 | 450 |
| WRF125 | 0.49 | 12.5 | 17.72 | 450 |
| WRF145 | 0.57 | 14.5 | 17.72 | 450 |
| WRF165 | 0.65 | 16.5 | 17.72 | 450 |
| WRF205 | 0.81 | 20.5 | 17.72 | 450 |

| Part Number | A | | C | |
|-------------|------|------|-------|-----|
| | Inch | mm | Inch | mm |
| WRA145 | 0.57 | 14.5 | 11.81 | 300 |
| WRA170 | 0.67 | 17.0 | 11.81 | 300 |
| WRA185 | 0.73 | 18.5 | 11.81 | 300 |
| WRA205 | 0.81 | 20.5 | 11.81 | 300 |
| WRA225 | 0.89 | 22.5 | 11.81 | 300 |
| WRA245 | 0.96 | 24.5 | 11.81 | 300 |
| WRA265 | 1.04 | 26.5 | 11.81 | 300 |
| WRA305 | 1.20 | 30.5 | 11.81 | 300 |
| WRA340 | 1.34 | 34.0 | 17.72 | 450 |
| WRA365 | 1.44 | 36.5 | 17.72 | 450 |
| WRA425 | 1.67 | 42.5 | 17.72 | 450 |
| WRA455 | 1.79 | 45.5 | 17.72 | 450 |
| WRA490 | 1.93 | 49.0 | 17.72 | 450 |
| WRA525 | 2.07 | 52.5 | 17.72 | 450 |
| WRA600 | 2.36 | 60.0 | 17.72 | 450 |

HS – Containment Grips

- Material: electrogalvanized steel wire

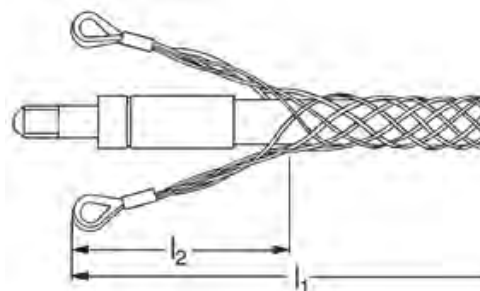

| Part Number | Hose I.D. | | | | Ø mm | Working load kN | Breaking load kN | Total length | |
|-------------|-----------|------|------|------|---------|--------------------|---------------------|--------------|----------|
| | DN | Inch | Size | mm | | | | l1 mm | l2 mm |
| HS-03 | 5 | 3/16 | -3 | 4.8 | 9 - 15 | 3 | 9 | 600 | 200 |
| HS-05 | 8 | 5/16 | -5 | 7.9 | 12 - 20 | 6 | 18 | 600 | 200 |
| HS-08 | 12 | 1/2 | -8 | 12.7 | 20 - 30 | 11 | 33 | 600 | 200 |
| HS-12 | 20 | 3/4 | -12 | 19.0 | 30 - 40 | 11 | 33 | 600 | 200 |
| HS-16 | 25 | 1 | -16 | 25.4 | 40 - 50 | 16 | 48 | 600 | 200 |

Thread Identification Kit

The thread identification tools are useful to help you identify international threads such as:

- European threads (Metric, BSPP, BSPT threads) and
- U.S. threads (NPT and SAE straight threads UNF)



Technical / Order Data

Thread identification kit
with thread gauges, a set of callipers, thread profiles and instruction booklet

| | | |
|--------------------|---------|-------------------|
| Part Number | English | H905375-GB |
| Part Number | German | H905375-DE |
| Part Number | French | H905375-FR |

The components of the thread ID Kit are not high-precision gauges but simple instruments for workshop use.

Accessories

Parker „Hoze-Oil“

Parker's hose assembly lubricant is pressure and temperature resistant. The lubrication effect will help to insert Parker No-Skive hose and fittings. If necessary simply wet the fitting end with a drop of hoze oil.

Volume

1 l

Part Number

Hoze-Oil



OilOn TH 11-3

Oiling pad for lubrication of fittings

The perfect way to lubricate the fitting, making it easier to insert into the hose. A foam rubber sponge that evenly disperses the oil onto the fitting, in an effective and easy manner.

Material

steel/plastic

Dimensions

L 130 x W 130 x H 70 mm

Part Number

TH11-3

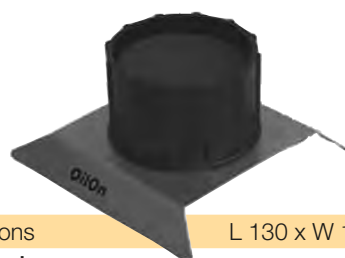

Push-Lok® Assembly Oil H896137

Water-oil emulsion for easier assembly of Parker Push-Lok® fittings. This product is very useful in combination with 830M, 837BM and 837PU hoses as the Push-Lok® assembly oil is free from wetting disturbing substances, e.g. silicone (Labs-free).

Volume

1 l

Part Number

H896137



KarryKrimp® 1 / KarryKrimp® 2

KarryKrimp 1 crimps Parkrimp® fittings 16, 26, 43, 46, 48 series size -4 up to -20

KarryKrimp 2 crimps Parkrimp® fittings 16, 26, 43, 46, 48, 70, 73 and 77 series

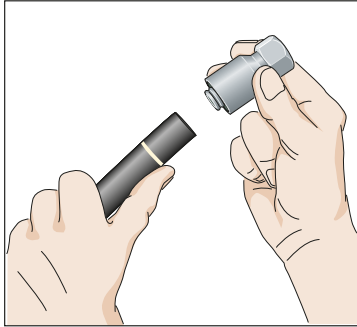

1. Mark the hose insertion depth acc. crimpable with a marker and push hose into fitting until the mark on the hose is even with the end of the shell. If necessary simply wet the fitting end with a drop of hose oil. Do not lubricate if using spiral hose.

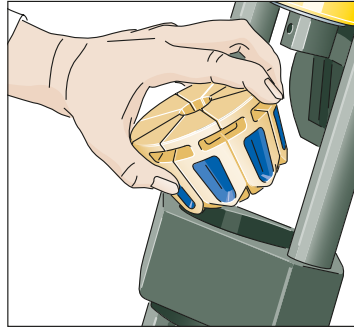

2. Pull pin and drop hinged die-train in place. Pay attention to die segment location.

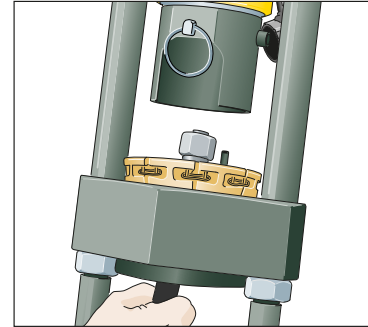

3. Insert fitting into the dies. Release, fitting will self position.



3. (a) Position the fitting on the die step.

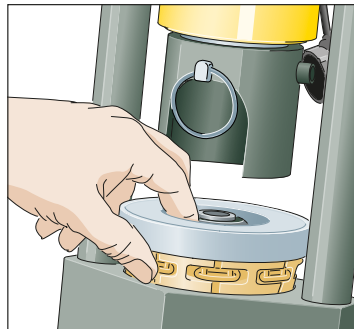

4. Place die ring on top of the dies.

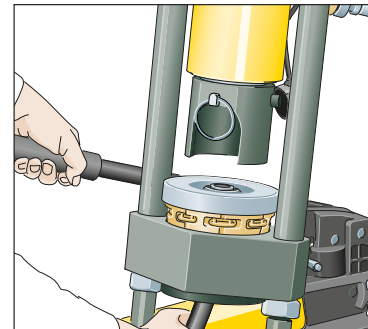

5. Position cylinder and replace pin. Pump until die ring contacts base plate.

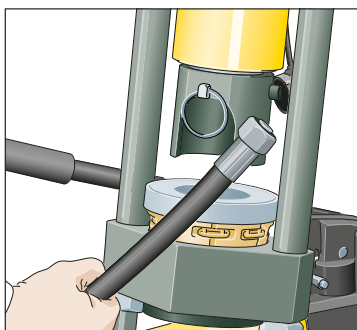

6. Release pressure
– remove finished assembly.

Parkrimp® 2

Parkrimp® fittings 16, 26, 43, 46, 48, 70, 73 and 77 series

For one-piece die sets 80C- ... and 83C- ... size -4 to -16



With the pusher in the full up position, lift the back half of the split die ring. Lock it in the up position by pushing the slide pin in (the slide pin is located inside the pusher at the back).

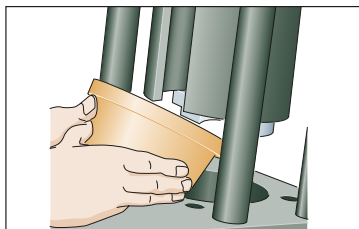

Carefully insert the adapter bowl into the base bowl. The adapter bowl must be tilted toward the back of the crimper during insertion.

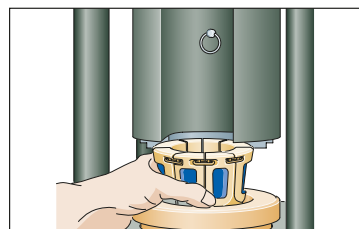

Insert the proper size and series die set into the adapter bowl.
Note: die sets are colour coded by size and have the fitting series and dash size stamped on the top.
Pay attention to die segment location.

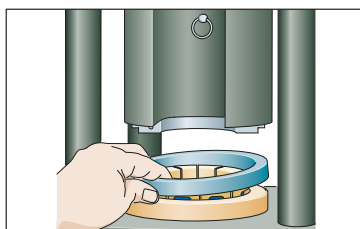

When swaging 43 series fittings on 100R2, 100R3, 100R4 and 100R9 type hose, the black spacer ring must be placed.

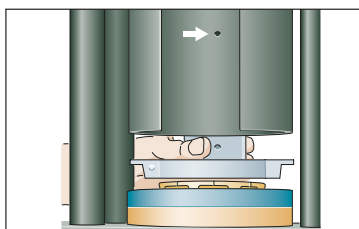

Lower the back half of the split die ring onto the dies by pulling the slide pin forward.



Insert the front half of the split die ring aligning the pin in the half with the hole in the front half.

For two-piece die sets 83C-... size -20 to -32

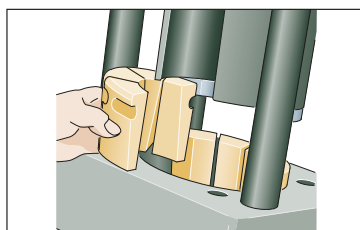

Insert the proper size die set into the die bowl (the die sets are in two halves of four dies each; Place one half in the back and one half in the front to facilitate removal of bent tube fittings).

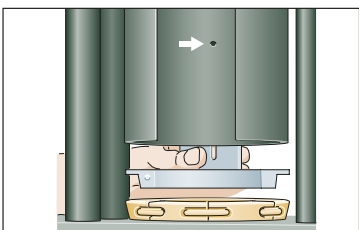

Lower the back half of the split die ring onto the dies by pulling the slide pin forward.

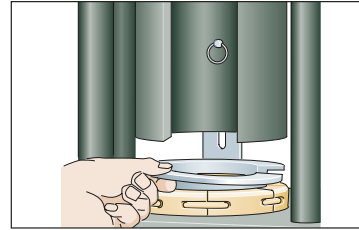

Insert the front half of the split die ring aligning the pin in the half with the hole in the front half.



Parkalign® feature
Position hose from below in dies.
Rest bottom of coupling on die step.

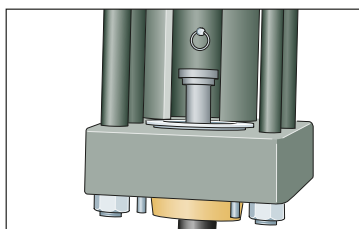

Turn on the pump by pressing the button on the left hand switch box. Lower the pusher by pressing the lower button on the right hand switch box. When the die ring contacts the base plate, the swaging is complete.

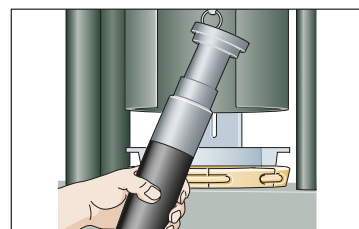

Push the black button at the top of the switch box to open dies and remove the finished assembly.
You do not have to remove any tooling to remove or insert straight fittings. The front half of the split die ring and the front die train must be removed to insert and remove bent tube fittings.

Your crimpsource online keeps you always up-to-date

Crimpsource online is your tool for a fast, easy and exact assembly of hose products in Europe

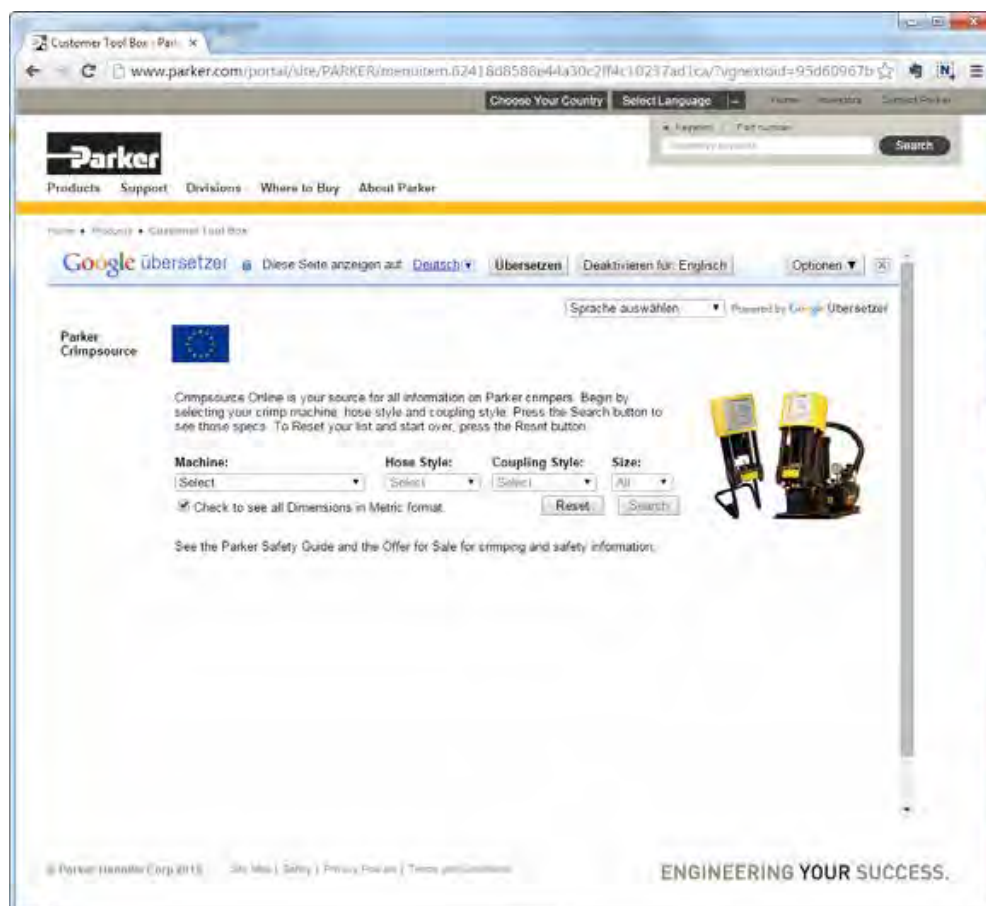

Find the correct crimp specification on the push of a button!

www.parker.com/crimpsource-euro

Catalogue 4400/UK

Part Number Index

| Part Number | Page | Part Number | Page | Part Number | Page | Part Number | Page |
|-------------|--------|-------------|-------|-------------|--------|-------------|-------|
| 187 | Caa-1 | 10648 | Cc-21 | 19246 | Cc-10 | 14A77 | Dd-10 |
| 201 | B2a-1 | 10670 | Db-9 | 19248 | Cc-10 | 14F73 | Dc-10 |
| 206 | B2a-2 | 10673 | Dc-8 | 19270 | Db-5 | 14F77 | Dd-11 |
| 213 | B2a-3 | 10677 | Dd-8 | 19273 | Dc-5 | 14N73 | Dc-11 |
| 244 | B2a-5 | 10826 | B2b-4 | 30182 | B1b-11 | 14N77 | Dd-12 |
| 285 | B2a-6 | 10848 | Cc-22 | 30282 | B1b-11 | 15S26 | B2b-7 |
| 293 | B2a-7 | 11543 | Cb-11 | 30382 | B1b-12 | 15T26 | B2b-7 |
| 304 | Cab-5 | 11546 | Cc-25 | 30682 | B1b-12 | 16A43 | Cb-12 |
| 372 | Dab-2 | 11548 | Cc-25 | 30882 | B1b-13 | 16A46 | Cc-28 |
| 387 | Caa-4 | 11570 | Db-11 | 33482 | B1b-10 | 16A48 | Cc-28 |
| 412 | Cab-6 | 11573 | Dc-10 | 33782 | B1b-13 | 16A70 | Db-12 |
| 426 | Cab-12 | 11577 | Dd-10 | 33982 | B1b-14 | 16A73 | Dc-11 |
| 436 | Cab-13 | 11743 | Cb-11 | 34982 | B1b-6 | 16A77 | Dd-13 |
| 441 | Cab-14 | 11746 | Cc-26 | 38282 | B1b-17 | 16F46 | Cc-28 |
| 462 | Cab-17 | 11748 | Cc-26 | 39182 | B1b-10 | 16F48 | Cc-28 |
| 463 | Cab-22 | 11770 | Db-11 | 39282 | B1b-8 | 16F70 | Db-13 |
| 477 | Cab-24 | 11773 | Dc-10 | 711509 | Eb-7 | 16F73 | Dc-12 |
| 487 | Caa-7 | 11777 | Dd-11 | 853009 | Eb-6 | 16F77 | Dd-14 |
| 492 | Cab-28 | 11943 | Cb-12 | 16E73 | Dc-12 | 16N43 | Cb-13 |
| 493 | Cab-31 | 11946 | Cc-27 | 16E77 | Dd-14 | 16N46 | Cc-29 |
| 681 | B2a-9 | 11948 | Cc-27 | 020__N0552 | Eb-4 | 16N48 | Cc-29 |
| 692 | Cab-32 | 11970 | Db-12 | 0202__N0552 | Eb-8 | 16N70 | Db-13 |
| 701 | Dab-11 | 11973 | Dc-11 | 100IF | Ce-1 | 16N73 | Dc-13 |
| 722 | Daa-1 | 11977 | Dd-12 | 100V4 | Df-1 | 16N77 | Dd-15 |
| 731 | Dab-13 | 13726 | B2b-4 | 100V5 | Dg-1 | 187ST | Caa-3 |
| 774 | Dab-15 | 13743 | Cb-10 | 100V6 | Df-1 | 187TC | Caa-2 |
| 787 | Daa-4 | 13746 | Cc-22 | 100VS | De-1 | 1B143 | Cb-5 |
| 797 | Daa-7 | 13748 | Cc-22 | 100WB | Dh-1 | 1B146 | Cc-11 |
| 804 | B1a-3 | 13770 | Db-10 | 10C43 | Cb-3 | 1B148 | Cc-11 |
| 811 | Cab-37 | 13773 | Dc-8 | 10C46 | Cc-6 | 1B170 | Db-5 |
| 836 | B1a-6 | 13777 | Dd-9 | 10C48 | Cc-6 | 1B173 | Dc-5 |
| 846 | B1a-10 | 13926 | B2b-5 | 10C70 | Db-3 | 1B243 | Cb-6 |
| 881 | Cab-39 | 13943 | Cb-10 | 10C73 | Dc-3 | 1B246 | Cc-12 |
| 10048 | Cd-1 | 13946 | Cc-23 | 10C77 | Dd-3 | 1B248 | Cc-12 |
| 10126 | B2b-3 | 13948 | Cc-23 | 11C43 | Cb-4 | 1B270 | Db-6 |
| 10146 | Cc-19 | 13970 | Db-10 | 11C46 | Cc-7 | 1B273 | Dc-6 |
| 10148 | Cc-19 | 13973 | Dc-9 | 11C48 | Cc-7 | 1B446 | Cc-13 |
| 10170 | Db-8 | 13977 | Dd-9 | 11C70 | Db-4 | 1B448 | Cc-13 |
| 10173 | Dc-7 | 14146 | Cc-24 | 11C73 | Dc-3 | 1B546 | Cc-18 |
| 10177 | Dd-7 | 14148 | Cc-24 | 11C77 | Dd-4 | 1B548 | Cc-18 |
| 10343 | Cb-9 | 14926 | B2b-2 | 13V26 | B2b-4 | 1C943 | Cb-3 |
| 10346 | Cc-20 | 14946 | Cc-9 | 13V46 | Cc-22 | 1C946 | Cc-5 |
| 10348 | Cc-20 | 14948 | Cc-9 | 13V48 | Cc-22 | 1C948 | Cc-5 |
| 10370 | Db-8 | 16826 | B2b-3 | 13W46 | Cc-23 | 1C970 | Db-3 |
| 10373 | Dc-7 | 16846 | Cc-21 | 13W48 | Cc-23 | 1C973 | Dc-2 |
| 10377 | Dd-7 | 16848 | Cc-21 | 13W70 | Db-10 | 1C977 | Dd-3 |
| 10626 | B2b-3 | 19146 | Cc-18 | 13Y46 | Cc-24 | 1CA26 | B2b-1 |
| 10643 | Cb-9 | 19148 | Cc-18 | 13Y48 | Cc-24 | 1CA43 | Cb-1 |
| 10646 | Cc-21 | 19243 | Cb-5 | 14A73 | Dc-10 | 1CA46 | Cc-1 |

Catalogue 4400/UK

Part Number Index

| Part Number | Page | Part Number | Page | Part Number | Page | Part Number | Page |
|-------------|-------|-------------|-------|-------------|--------|-------------|--------|
| 1CA48 | Cc-1 | 1EC70 | Db-7 | 1JS73 | Dc-16 | 3D982 | B1b-9 |
| 1CA70 | Db-1 | 1EC77 | Dd-6 | 1K577 | Dd-19 | 3FF82 | B1b-16 |
| 1CA73 | Dc-1 | 1EN46 | Cc-41 | 1K777 | Dd-20 | 3JC82 | B1b-15 |
| 1CA77 | Dd-1 | 1EN48 | Cc-41 | 1K977 | Dd-20 | 405.906 | Ea-19 |
| 1CE26 | B2b-1 | 1ET46 | Cc-42 | 1MZ46 | Cc-37 | 412ST | Cab-7 |
| 1CE43 | Cb-1 | 1ET48 | Cc-42 | 1MZ48 | Cc-37 | 421RH | Cab-8 |
| 1CE46 | Cc-2 | 1EU46 | Cc-41 | 1NW46 | Cc-38 | 421SN | Cab-9 |
| 1CE48 | Cc-2 | 1EU48 | Cc-41 | 1NW48 | Cc-38 | 421TC | Cab-10 |
| 1CE70 | Db-1 | 1FG77 | Dd-24 | 1PW46 | Cc-39 | 421WC | Cab-11 |
| 1CE73 | Dc-1 | 1FU46 | Cc-36 | 1PW48 | Cc-39 | 441RH | Cab-15 |
| 1CE77 | Dd-1 | 1FU48 | Cc-36 | 1PY70 | Db-14 | 461LT | Cab-16 |
| 1CF26 | B2b-2 | 1GU46 | Cc-36 | 1X577 | Dd-16 | 462PU | Cab-18 |
| 1CF43 | Cb-2 | 1GU48 | Cc-36 | 1X777 | Dd-16 | 462PU Twin | Cab-19 |
| 1CF46 | Cc-3 | 1J146 | Cc-34 | 1X977 | Dd-17 | 462ST | Cab-21 |
| 1CF48 | Cc-3 | 1J148 | Cc-34 | 1XA73 | Dc-13 | 462TC | Cab-20 |
| 1CF70 | Db-2 | 1J170 | Db-17 | 1XA77 | Dd-17 | 471TC | Cab-23 |
| 1CF73 | Dc-2 | 1J177 | Dd-22 | 1XF73 | Dc-14 | 477RH | Cab-25 |
| 1CF77 | Dd-2 | 1J546 | Cc-34 | 1XF77 | Dd-18 | 477ST | Cab-27 |
| 1CW46 | Cc-38 | 1J548 | Cc-34 | 1XG73 | Dc-14 | 477TC | Cab-26 |
| 1CW48 | Cc-38 | 1J743 | Cb-15 | 1XG77 | Dd-18 | 487ST | Caa-9 |
| 1D043 | Cb-2 | 1J746 | Cc-32 | 1XN73 | Dc-15 | 487TC | Caa-8 |
| 1D046 | Cc-4 | 1J748 | Cc-32 | 1XN77 | Dd-19 | 492ST | Cab-30 |
| 1D048 | Cc-4 | 1J770 | Db-16 | 1XU48 | Cc-40 | 492TC | Cab-29 |
| 1D070 | Db-2 | 1J773 | Dc-17 | 1XU70 | Db-18 | 50H | Eb-1 |
| 1D077 | Dd-2 | 1J777 | Dd-21 | 1XU73 | Dc-19 | 600.4 | Ea-15 |
| 1D243 | Cb-4 | 1J943 | Cb-15 | 1XY70 | Db-1 | 611050G | Ea-33 |
| 1D246 | Cc-8 | 1J946 | Cc-33 | 2-0_N552-90 | Eb-7 | 611050HV | Ea-33 |
| 1D248 | Cc-8 | 1J948 | Cc-33 | 221FR | B2a-4 | 611HT | B2a-8 |
| 1D270 | Db-4 | 1J970 | Db-16 | 301SN | Cab-4 | 681DB | B2a-10 |
| 1D273 | Dc-4 | 1J973 | Dc-17 | 35C82 | B1b-17 | 692PU | Cab-34 |
| 1D277 | Dd-4 | 1J977 | Dd-22 | 36C82 | B1b-18 | 692PU Twin | Cab-35 |
| 1D943 | Cb-8 | 1JC26 | B2b-6 | 371LT | Dab-1 | 692TC | Cab-36 |
| 1D946 | Cc-17 | 1JC43 | Cb-14 | 372RH | Dab-3 | 692Twin | Cab-33 |
| 1D948 | Cc-17 | 1JC46 | Cc-30 | 372TC | Dab-4 | 701TC | Dab-12 |
| 1D970 | Db-7 | 1JC48 | Cc-30 | 37C82 | B1b-18 | 722ST | Daa-3 |
| 1D973 | Dc-6 | 1JC70 | Db-15 | 387ST | Caa-6 | 722TC | Daa-2 |
| 1D977 | Dd-6 | 1JC73 | Dc-16 | 387TC | Caa-5 | 731TC | Dab-14 |
| 1EA43 | Cb-6 | 1JC77 | Dd-21 | 39B82 | B1b-6 | 787ST | Daa-6 |
| 1EA46 | Cc-14 | 1JD46 | Cc-35 | 39C82 | B1b-7 | 787TC | Daa-5 |
| 1EA48 | Cc-14 | 1JD48 | Cc-35 | 3AF82 | B1b-16 | 797RH | Dab-16 |
| 1EA70 | Db-6 | 1JM46 | Cc-35 | 3B182 | B1b-8 | 797ST | Daa-9 |
| 1EA77 | Dd-5 | 1JM48 | Cc-35 | 3B282 | B1b-9 | 797TC | Daa-8 |
| 1EB43 | Cb-7 | 1JM70 | Db-17 | 3C382 | B1b-3 | 801PLUS | B1a-1 |
| 1EB46 | Cc-15 | 1JM73 | Dc-18 | 3C482 | B1b-4 | 801RH | B1a-2 |
| 1EB48 | Cc-15 | 1JM77 | Dd-23 | 3C582 | B1b-5 | 80C-ODR | Ea-6 |
| 1EB77 | Dd-5 | 1JS43 | Cb-14 | 3CA82 | B1b-1 | 811S | Cab-38 |
| 1EC43 | Cb-7 | 1JS46 | Cc-31 | 3CE82 | B1b-1 | 821FR | B1a-4 |
| 1EC46 | Cc-16 | 1JS48 | Cc-31 | 3CF82 | B1b-2 | 82C-2HP | Ea-5 |
| 1EC48 | Cc-16 | 1JS70 | Db-15 | 3D082 | B1b-2 | 82CE-00L | Ea-5 |

Catalogue 4400/UK

Part Number Index

| Part Number | Page | Part Number | Page | Part Number | Page | Part Number | Page |
|-------------|--------|-------------|--------|-------------|-------|----------------|-------|
| 82CE-061L | Ea-1 | FU-HMX | Ea-24 | K1CV5 | Dg-3 | KCAV4 | Df-2 |
| 82CE-0EP | Ea-5 | FU-HMX | Ea-25 | K1CV6 | Df-4 | KCAV6 | Df-2 |
| 82CE-CHD | Ea-1 | H29 | Dab-18 | K1CVS | De-5 | KCAVS | De-2 |
| 82C-R01 | Ea-1 | H29ST | Dab-20 | K37V4 | Df-10 | KCEV4 | Df-2 |
| 82C-R02 | Ea-1 | H29TC | Dab-19 | K37V6 | Df-10 | KCEV6 | Df-2 |
| 830M | B1a-5 | H31 | Dab-21 | K37VS | De-9 | KCEVS | De-2 |
| 837BM | B1a-7 | H31ST | Dab-23 | K39V4 | Df-11 | KCFV4 | Df-3 |
| 837PU-Plus | B1a-8 | H31TC | Dab-22 | K39V6 | Df-11 | KCFV6 | Df-3 |
| 838M | B1a-9 | H896137 | Eb-24 | K39VS | De-10 | KCFVS | De-3 |
| 83C-0CB | Ea-4 | H899770 | Ea-19 | K3VVS | De-9 | KD0VS | De-3 |
| 83C-0DR | Ea-6 | H899771 | Ea-15 | K3WVS | De-10 | KD2V4 | Df-5 |
| 83CE-083U | Ea-4 | H899959 | Ea-15 | K4AV4 | Df-12 | KD2V6 | Df-5 |
| 83C-R02 | Ea-4 | H905375__ | Eb-23 | K4AV6 | Df-12 | KD2VS | De-5 |
| 83C-R02H | Ea-4 | HG | Eb-18 | K4FV4 | Df-13 | KD9V4 | Df-7 |
| 85C-0AP | Ea-5 | Hoze-Oil | Eb-24 | K4FV6 | Df-13 | KD9V6 | Df-7 |
| 85CE-00L | Ea-1 | HP-B | Eb-21 | K4NV4 | Df-14 | KD9VS | De-7 |
| 85CE-00L | Ea-2 | HS | Eb-23 | K4NV6 | Df-14 | KJ7V4 | Df-24 |
| 85CE-00L | Ea-5 | HT2 | Cab-3 | K68VS | De-9 | KJ7V6 | Df-24 |
| 85CE-061L | Ea-2 | K0147 | Cd-1 | K6AV4 | Df-15 | KJ7VS | De-14 |
| 85CE-0HP | Ea-5 | K01V4 | Df-9 | K6AV6 | Df-15 | KJ9V4 | Df-24 |
| 85CE-1PE | Ea-3 | K01V6 | Df-9 | K6AVS | De-12 | KJ9V6 | Df-24 |
| 85CE-1PE | Ea-5 | K01VS | De-8 | K6FV4 | Df-16 | KJ9VS | De-15 |
| 85CE-CHD | Ea-2 | K01WB | Dh-4 | K6FV6 | Df-16 | KJCV4 | Df-23 |
| 85CE-XAM | Ea-5 | K03V4 | Df-9 | K6FVS | De-13 | KJCV6 | Df-23 |
| 85C-R01 | Ea-2 | K03V6 | Df-9 | K6NV4 | Df-17 | KJCVS | De-14 |
| 85C-R02 | Ea-2 | K03VS | De-8 | K6NV6 | Df-17 | KJMV4 | Df-25 |
| 85C-STD | Ea-1 | K06V4 | Df-10 | K6NVS | De-13 | KJSV4 | Df-23 |
| 85C-STD | Ea-2 | K06V6 | Df-10 | K8AV4 | Df-18 | KX5V6 | Df-19 |
| 8FH-__-SM | Eb-1 | K06VS | De-9 | K8AV6 | Df-18 | KX7V6 | Df-20 |
| AG | Eb-13 | K0CV4 | Df-4 | K8FV4 | Df-18 | KX9V6 | Df-20 |
| AM | Eb-6 | K0CV5 | Dg-2 | K8FV6 | Df-18 | KXAV4 | Df-21 |
| AR | Eb-6 | K0CV6 | Df-4 | K8NV4 | Df-19 | KXAV6 | Df-21 |
| AS-B | Eb-14 | K0CVS | De-4 | K8NV6 | Df-19 | KXfV4 | Df-21 |
| AS-Y | Eb-14 | K1547 | Cd-2 | K91V4 | Df-8 | KXfV6 | Df-21 |
| BCH1 | Cab-1 | K15IF | Ce-2 | K92V4 | Df-6 | KXGV4 | Df-22 |
| BCH2 | Cab-2 | K15V4 | Df-12 | K92V6 | Df-6 | KXGV6 | Df-22 |
| BPK | Dab-30 | K15V6 | Df-12 | K92VS | De-6 | KXNV4 | Df-22 |
| C9RG | Eb-7 | K15VS | De-11 | K92WB | Dh-3 | KXNV6 | Df-22 |
| C9RG | Eb-8 | K1747 | Cd-2 | KB1V4 | Df-6 | M__ | Eb-9 |
| CARG | Eb-8 | K17IF | Ce-2 | KB1V6 | Df-6 | MS__N | Eb-9 |
| CEM69TC | Dab-33 | K17V4 | Df-13 | KB1VS | De-6 | PB237.239.2L2 | Ea-24 |
| DMS | Eb-16 | K17V6 | Df-13 | KB2V4 | Df-7 | PB237.239.2L2 | Ea-25 |
| EARG | Eb-7 | K17VS | De-11 | KB2V6 | Df-7 | PB237.239.2L2 | Ea-26 |
| EM 10.P | Ea-7 | K1947 | Cd-2 | KB2VS | De-7 | PB245.237L | Ea-26 |
| F42 | Dab-17 | K19IF | Ce-3 | KC9V4 | Df-3 | PB266.239L | Ea-23 |
| FA35 | Dab-31 | K19V4 | Df-14 | KC9V5 | Dg-2 | PBSET-237L-IH | Ea-25 |
| FHS3__CFX | Eb-1 | K19V6 | Df-14 | KC9V6 | Df-3 | PBSET-TH8E-200 | Ea-22 |
| FHS6__CFX | Eb-1 | K19VS | De-12 | KC9VS | De-4 | PBSET-TH8E-380 | Ea-25 |
| FS-F | Eb-17 | K1CV4 | Df-4 | KC9WB | Dh-2 | PBSET-TH8E-53X | Ea-23 |

Catalogue 4400/UK

Part Number Index

| Part Number | Page | Part Number | Page | Part Number | Page | Part Number | Page |
|-----------------|--------|-------------------|-------|--------------|-------|-------------|------|
| PBSET-TH8E-800 | Ea-24 | TH2-9-3PH | Ea-27 | UNC__ | Eb-2 | | |
| PBSET-TH8E-800 | Ea-24 | TH3-2-12VDC | Ea-8 | UNC__ | Eb-3 | | |
| PCS-__B | Ea-31 | TH3E-110 | Ea-12 | UNC__ | Eb-5 | | |
| PCS-__P | Ea-31 | TH3E-115 | Ea-11 | UPTH-11b-PW3 | Ea-14 | | |
| PG | Eb-19 | TH3E-EM6-M | Ea-10 | UPTH-22b | Ea-14 | | |
| PS-B | Eb-15 | TH3E-EM6-P | Ea-10 | UPTS 100 | Ea-14 | | |
| PS-BV | Eb-20 | TH4-10 | Ea-13 | VERG | Eb-7 | | |
| QDC239.3 | Ea-22 | TH4-4U | Ea-14 | VURG | Eb-7 | | |
| QDC239.5 | Ea-23 | TH4-7 | Ea-13 | WKS | Eb-20 | | |
| QDC239.5 | Ea-24 | TH4-8 | Ea-13 | WRA | Eb-22 | | |
| QDC239.5 | Ea-25 | TH4-9 | Ea-13 | WRC | Eb-22 | | |
| QDC239.5 | Ea-26 | TH4-9-1 | Ea-13 | WRF | Eb-22 | | |
| QDS239S | Ea-23 | TH5-3 | Ea-19 | XARG | Eb-8 | | |
| QDS239S | Ea-24 | TH5-3-BM | Ea-19 | ZYLS__VZX | Eb-2 | | |
| QDS239S | Ea-25 | TH6-10-EL-8 | Ea-17 | ZYLS__VZX | Eb-3 | | |
| R-__-CFX | Eb-4 | TH6-10-H__ | Ea-17 | ZYLS__VZX | Eb-5 | | |
| R__X | Eb-4 | TH6-10-H__ | Ea-18 | ZYLS__X | Eb-3 | | |
| R35 | Dab-24 | TH6-10-P__ | Ea-17 | | | | |
| R35TC | Dab-25 | TH6-10-P__ | Ea-18 | | | | |
| R42 | Dab-26 | TH6-6 | Ea-15 | | | | |
| R42ST | Dab-28 | TH6-7 | Ea-16 | | | | |
| R42TC | Dab-27 | TH6-7-30 | Ea-16 | | | | |
| R50TC | Dab-29 | TH6-7-55 | Ea-16 | | | | |
| R56TC | Dab-29 | TH7-12 | Ea-20 | | | | |
| RD35TC | Dab-32 | TH7-13 | Ea-20 | | | | |
| RS35TC-48 | Dab-25 | TH7-14 | Ea-21 | | | | |
| S__ | Eb-10 | TH7-15 | Ea-21 | | | | |
| SG | Eb-12 | TH8E-200 | Ea-22 | | | | |
| SHS375-380 | Ea-25 | TH8E-200-ECO | Ea-22 | | | | |
| SHS-800 | Ea-24 | TH8E-380-CM | Ea-25 | | | | |
| SS__N | Eb-10 | TH8E-480-CM | Ea-26 | | | | |
| SX35 | Dab-5 | TH8E-530 | Ea-23 | | | | |
| SX35LT | Dab-6 | TH8E-530-CM | Ea-23 | | | | |
| SX35TC | Dab-7 | TH8E-535-CM | Ea-23 | | | | |
| SX42 | Dab-8 | TH8E-800 | Ea-24 | | | | |
| SX42LT | Dab-9 | TH8E-800-CM | Ea-24 | | | | |
| SX42TC | Dab-10 | TH8-LUS | Ea-25 | | | | |
| TA380/A | Ea-25 | TH8-LUS | Ea-26 | | | | |
| TA800/A | Ea-24 | TM 160 x 2,5 x 20 | Ea-7 | | | | |
| TH 3E-EM3 | Ea-9 | TM250x2x40Z | Ea-8 | | | | |
| TH 8E-200-24VDC | Ea-22 | TMC520x4x40 | Ea-11 | | | | |
| TH 8E-200VDC | Ea-22 | TMC520x4x40 | Ea-12 | | | | |
| TH11-3 | Eb-24 | TMG275x3x30 | Ea-9 | | | | |
| TH1E-5 | Ea-33 | TMG350x3x30 | Ea-10 | | | | |
| TH2-10-3PH | Ea-28 | TMG350x3x30 | Ea-10 | | | | |
| TH2-11__ | Ea-30 | UC-1.5HD | Ea-32 | | | | |
| TH2-12__ | Ea-30 | UC-CSS-230VE-G2 | Ea-32 | | | | |
| TH2-13-3PH | Ea-29 | UC-HG-STAND | Ea-32 | | | | |
| TH2-9-1PH | Ea-27 | UC-HL-1910E-EU | Ea-32 | | | | |

Parker's Motion & Control Technologies

At Parker, we're guided by a relentless drive to help our customers become more productive and achieve higher levels of profitability by engineering the best systems for their requirements. It means looking at customer applications from many angles to find new ways to create value. Whatever the motion and control technology need, Parker has the experience, breadth of product and global reach to consistently deliver. No company knows more about motion and control technology than Parker.

For further info call
00800 27 27 5374



Aerospace

Key Markets

Aftermarket services
Commercial transports
Engines
General & business aviation
Helicopters
Launch vehicles
Military aircraft
Missiles
Power generation
Regional transports
Unmanned aerial vehicles

Key Products

Control systems & actuation products
Engine systems & components
Fluid conveyance systems & components
Fluid metering, delivery & atomization devices
Fuel systems & components
Fuel tank inerting systems
Hydraulic systems & components
Thermal management
Wheels & brakes



Climate Control

Key Markets

Agriculture
Air conditioning
Construction Machinery
Food & beverage
Industrial machinery
Life sciences
Oil & gas
Precision cooling
Process
Refrigeration
Transportation

Key Products

Accumulators
Advanced actuators
CO₂ controls
Electronic controllers
Filter driers
Hand shut-off valves
Heat exchangers
Hose & fittings
Pressure regulating valves
Refrigerant distributors
Safety relief valves
Smart pumps
Solenoid valves
Thermostatic expansion valves



Hydraulics

Key Markets

Aerial lift
Agriculture
Alternative energy
Construction machinery
Forestry
Industrial machinery
Machine tools
Marine
Material handling
Mining
Oil & gas
Power generation
Refuse vehicles
Renewable energy
Truck hydraulics
Turf equipment

Key Products

Accumulators
Cartridge valves
Electrohydraulic actuators
Human machine interfaces
Hybrid drives
Hydraulic cylinders
Hydraulic motors & pumps
Hydraulic systems
Hydraulic valves & controls
Hydrostatic steering
Integrated hydraulic circuits
Power take-offs
Power units
Rotary actuators
Sensors



Pneumatics

Key Markets

Aerospace
Conveyor & material handling
Factory automation
Life science & medical
Machine tools
Packaging machinery
Transportation & automotive

Key Products

Air preparation
Brass fittings & valves
Manifolds
Pneumatic accessories
Pneumatic actuators & grippers
Pneumatic valves & controls
Quick disconnects
Rotary actuators
Rubber & thermoplastic hose & couplings
Structural extrusions
Thermoplastic tubing & fittings
Vacuum generators, cups & sensors



Electromechanical

Key Markets

Aerospace
Factory automation
Life science & medical
Machine tools
Packaging machinery
Paper machinery
Plastics machinery & converting
Primary metals
Semiconductor & electronics
Textile
Wire & cable

Key Products

AC/DC drives & systems
Electric actuators, gantry robots & slides
Electrohydraulic actuation systems
Electromechanical actuation systems
Human machine interface
Linear motors
Stepper motors, servo motors, drives & controls
Structural extrusions



Filtration

Key Markets

Aerospace
Food & beverage
Industrial plant & equipment
Life sciences
Marine
Mobile equipment
Oil & gas
Power generation & renewable energy
Process
Transportation
Water Purification

Key Products

Analytical gas generators
Compressed air filters & dryers
Engine air, coolant, fuel & oil filtration systems
Fluid condition monitoring systems
Hydraulic & lubrication filters
Hydrogen, nitrogen & zero air generators
Instrumentation filters
Membrane & fiber filters
Microfiltration
Sterile air filtration
Water desalination & purification filters & systems



Fluid & Gas Handling

Key Markets

Aerial lift
Agriculture
Bulk chemical handling
Construction machinery
Food & beverage
Fuel & gas delivery
Industrial machinery
Life sciences
Marine
Mining
Mobile
Oil & gas
Renewable energy
Transportation

Key Products

Check valves
Connectors for low pressure fluid conveyance
Deep sea umbilicals
Diagnostic equipment
Hose couplings
Industrial hose
Mooring systems & power cables
PTFE hose & tubing
Quick couplings
Rubber & thermoplastic hose
Tube fittings & adapters
Tubing & plastic fittings



Process Control

Key Markets

Alternative fuels
Biopharmaceuticals
Chemical & refining
Food & beverage
Marine & shipbuilding
Medical & dental
Microelectronics
Nuclear Power
Offshore oil exploration
Oil & gas
Pharmaceuticals
Power generation
Pulp & paper
Steel
Water/wastewater

Key Products

Analytical Instruments
Analytical sample conditioning products & systems
Chemical injection fittings & valves
Fluoropolymer chemical delivery fittings, valves & pumps
High purity gas delivery fittings, valves, regulators & digital flow controllers
Industrial mass flow meters/controllers
Permanent no-weld tube fittings
Precision industrial regulators & flow controllers
Process control double block & bleeds
Process control fittings, valves, regulators & manifold valves



Sealing & Shielding

Key Markets

Aerospace
Chemical processing
Consumer
Fluid power
General industrial
Information technology
Life sciences
Microelectronics
Military
Oil & gas
Power generation
Renewable energy
Telecommunications
Transportation

Key Products

Dynamic seals
Elastomeric o-rings
Electro-medical instrument design & assembly
EMI shielding
Extruded & precision-cut, fabricated elastomeric seals
High temperature metal seals
Homogeneous & inserted elastomeric shapes
Medical device fabrication & assembly
Metal & plastic retained composite seals
Shielded optical windows
Silicone tubing & extrusions
Thermal management
Vibration dampening

ENGINEERING YOUR SUCCESS.

www.parker.com



European Headquarters
La Tuilière 6, 1163 Etoy,
Switzerland
Tel: +41 21 821 85 00

© 2022 Parker Hannifin Corporation. All rights reserved. Bulletin BUL/C4400-A/UK 2022-08