



aerospace  
climate control  
electromechanical  
filtration  
fluid & gas handling  
**hydraulics**  
pneumatics  
process control  
sealing & shielding



# CVG Control Valve Group

Proportional, Load Sensing



ENGINEERING YOUR SUCCESS.

**Note**

FAILURE OR IMPROPER SELECTION OR IMPROPER USE OF THE PRODUCTS DESCRIBED HEREIN OR RELATED ITEMS CAN CAUSE DEATH, PERSONAL INJURY AND PROPERTY DAMAGE.

This document and other information from Parker-Hannifin Corporation, its subsidiaries and authorized distributors provide product or system options for further investigation by users having technical expertise.

The user, through its own analysis and testing, is solely responsible for making the final selection of the system and components and assuring that all performance, endurance, maintenance, safety and warning requirements of the application are met. The user must analyze all aspects of the application, follow applicable industry standards, and follow the information concerning the product in the current product catalog and in any other materials provided from Parker or its subsidiaries or authorized distributors. To the extent that Parker or its subsidiaries or authorized distributors provide component or system options based upon data or specifications provided by the user, the user is responsible for determining that such data and specifications are suitable and sufficient for all applications and reasonably foreseeable uses of the components or systems.

**Contents**

Description	Page
<b>Introduction</b>	<b>4</b>
General description, applications, benefits	4
Operation	5
<b>Technical data</b>	<b>6</b>
<b>Ordering code</b>	<b>7</b>
How to order CVG – CVG master code	7
Inlet section	8
Control section	9
Outlet section	10
Adapter section	11
<b>Measuring data CVG</b>	<b>12</b>
Pressure drop CVG compensator spools	12
<b>Measuring data CVG30</b>	<b>13</b>
Pressure drop CVG 30 spools	13
Compensator adjustment range CVG30	13
<b>Measuring data CVG50</b>	<b>14</b>
Pressure drop CVG 50 spools	14
Compensator adjustment range CVG50	14
<b>Measuring data CVG60</b>	<b>15</b>
Pressure drop CVG60 spools	15
Compensator adjustment range CVG60	15
<b>Spool Selection Table</b>	<b>16</b>
Standard spools	16
Meter out spools	16
<b>Assembly Diagrams</b>	<b>17</b>
CVG33 assembly example	17
Hydraulic diagram CVG33	17
CVG53 assembly example	18
Hydraulic diagram CVG53	18
CVG63 assembly example	19
Hydraulic diagram CVG63	19
<b>Dimensions CVG30</b>	<b>20</b>
Inlet section connections	20
Outlet section connections	20
Assembly, dimensions	21
Control section connections	21
<b>Dimensions CVG50</b>	<b>22</b>
Inlet section connections	22
Outlet section connections	22
Assembly, dimensions	23
Control section connections	23
<b>Dimensions CVG60</b>	<b>24</b>
Inlet section connections	24
Outlet section connections	24
Assembly, dimensions	25
Control section connections	25
<b>Spare Parts</b>	<b>26</b>
CVG30 control section	26
CVG50 control section	27
CVG60 control section	28
CVG30 inlet section with pressure relief	29
CVG50 inlet section with pressure relief	30
CVG60 inlet section with pressure relief	31
Adapters	32

## Introduction

### General description

The CVG (Control Valve Group) is a compact load-sensing valve assembly consisting of multiple directional valve sections. Each control section has its own compensator, so that speed control of multiple sections is achieved, regardless of changes in pressure. The compensator limits the maximum flow of control section and it can be adjusted. Each control section has pressure limiting valves in work ports. If load exceeds the setting, the control section starts to reduce flow. The control section keeps flow steady with different main spool opening if pressure changes.

The design of the CVG is modular. There are three nominal sizes of control sections available: CVG30, CVG50 and CVG60. Different sizes can be fitted together with adapters. The nominal size determines the port sizes and compensators flow range. Specific flow range is selected by a main spool in each control section. The inlet section has an option for a main pressure relief valve and a pilot oil reducing valve for electrically controlled CVG. The outlet section has also ports P and T to ensure full flow for control sections.

The main spool of control section can be operated proportionally with hydraulic remote or electrically in an open loop and also in a closed loop depending on option.

### Applications

A CVG can be used to control wide range of machines like cranes, large mobile vehicles, lifting equipment, drilling equipment and stationary applications. High flows can be accurately controlled with low pressure drop and low hysteresis.

## Mobile Directional Control Valve CVG

### Benefits

**Excellent machine controllability** – individual pressure compensation in each work section delivers predictable metering with single and multi-function operation, regardless of changes in pressure or input flow. The maximum work pressure can be limited individually in each work port. This enhances machine control and improves productivity. The CVG has excellent linearity, repeatability and low hysteresis.

**Flexible design** – the modular CVG design enables the machine designer to add or remove content to achieve the machine requirements. Different nominal sizes, several spools and a wide range of spool control options provide wide range of possibilities where to build customized assembly to meet the requirements.

**Wide flow range** – the CVG single control sections can handle flow starting from 50LPM in nominal size CVG30 ending up to 2000 LPM in CVG60. Inlet and outlet can handle pump input up to 10 000LPM in CVG60.

**Energy-efficient** – high level controllability and efficiency can be achieved by choosing the right spool size from different nominal sizes. CVG can handle load pressure up to 420 bar. With right system design this gives possibility to reduce oil flow and still have same power supplied through the valve.

**Factory tested** – every CVG valve assemblies are tested and adjusted before sending to the customer. This reduces start up time and reduces risk of system failure. Customer individual features can be fully tested before start up.

**Ease of service** – the components of CVG are easily changed without removing CVG from the system. Compensator, pressure limiting valves and load-sensing check valve are located on the top of each controls section making it a service friendly design. Spare parts are available worldwide from Parker.

**Operation**

Speed and direction movements of actuators are proportionally controlled by spring centered main spools. The pilot pressure moves the main spool against spring force. In the electric version pilot pressure is adjusted by electro-proportional 3-way pressure reduction valves. In the hydraulic version the pilot pressure is adjusted by an external control valve. The pilot oil flow to electro-proportional pilot valves is supplied either internally or externally. The internal signal is taken from port P through a pressure reducing valve in the inlet section.

The pressure difference over main spool is kept constant by a 2-way pressure compensator. Flow (and speed of actuator) with certain opening of the main spool is constant independent of load variations. Pressure compensators are equipped with adjustable springs. The spring force sets also a limit for maximum flow (speed of actuator). Maximum feeding pressures in work ports A and B are adjusted separately. When pressure exceeds setting of the pilot valve, the pressure compensator starts to act like a pressure reducing valve.

The CVG is a load sensing valve group. Every main spool is equipped with LS signal channels. The highest load pressure in the system is always connected to the LS port in the inlet section. This signal can be used to control a variable displacement pump. A CVG can be used with fixed displacement pumps when the inlet section is equipped with a 3-way pressure compensator. When the system pressure exceeds the setting of the pilot valve of the 3-way compensator, it starts to act like a pressure relief valve.

In the open loop version, the position of the main spool follows electric control signal coming from the amplifier card. The main spool can be equipped with a position sensor to read the movement of the main spool. In close loop control with electro-proportional control version, the position signal is sent to the amplifier card that compares position signal to command signal and corrects the control signal to solenoids accordingly. When having close loop control option in CVG, the electro proportional control end of spool is replaced with the close loop control valve end. It has onboard electronics to compare spool position to command signal and needs only power supply and command signal for the main spool position.

**Technical Data**

General			
Design	Control valve group with modular design		
Mounting positions	Optional		
Ambient temperature	[°C]	-30 ... +70	
Hydraulic			
Operating pressure	[bar]	350, peak pressure 420	
Fluid	Mineral oil in accordance with DIN51524 and DIN51525		
Fluid temperature	[°C]	-20 ... +90	
Viscosity permitted	[cSt] / [mm²/s]	15 ... 380	
Viscosity recommended	[cSt] / [mm²/s]	30 ... 80	
Filtration	ISO4406 (1999); 18/16/13		
Leakage at 40 cSt	[l/min]	Up to 3 with 350 bar, depending on spool	
Pilot pressure	[bar]	Internally 45, externally to port PP2 through pressure reducing valve 45-420 should be 45-350 supply to port PP2 for pressure reducing valve Max. pilot pressure 100	
Hydraulic pilot	[bar]	External remote control for spool 0 - 35	
Tank line	[bar]	Port T maximum pressure 30	
Drain pressure	[bar]	Port DR maximum pressure 1	
Nominal flow	Flow with 5 bar pressure drop over one control edge of main spool		
		<b>CVG30</b>	<b>CVG50</b>
	[l/min]	500 / section	800 / section
		<b>CVG60</b>	
	[l/min]	1200 / section	2000 / section
Maximum flow	[l/min]	750 / section	1200 / section
Main pressure relief	Maximum flow of single* pressure relief valve		
		<b>CVG30 inlet section</b>	<b>CVG50 inlet section</b>
	[l/min]	400	1200
		Parker A06G2PZN	Parker Lokomec CEL40
		<b>CVG60 inlet section</b>	1200
			Parker Lokomec CEL40
Static / Dynamic			
Step response	[ms]	Open loop step response 0 to 100 %	
		<b>CVG30</b>	<b>CVG50</b>
		300	600
		<b>CVG60</b>	600
		Closed loop control with onboard electronics <150 ms. Consult factory.	
Electrical characteristic			
Duty cycle	[%]	100	
Amplifier	Parker IQAN control systems or Parker amplifiers for proportional valves		
Protection class	IP65		
Current	[mA]	For spool control 0-800 mA (spool movement 300 - 750 mA)	
Solenoid connection	AMP Junior-Power-Timer (optional Deutsch DT04-2P connector)		
ATEX solenoids	Consult factory		
Surface treatment			
Painting	2-component epoxy primer RAL7004		

\*Outlet section can be equipped with secondary pressure relief. Adjustment is 10 bar higher than inlet pressure relief valve.

**Ordering Code**

**How to order CVG**

**CVG master code**

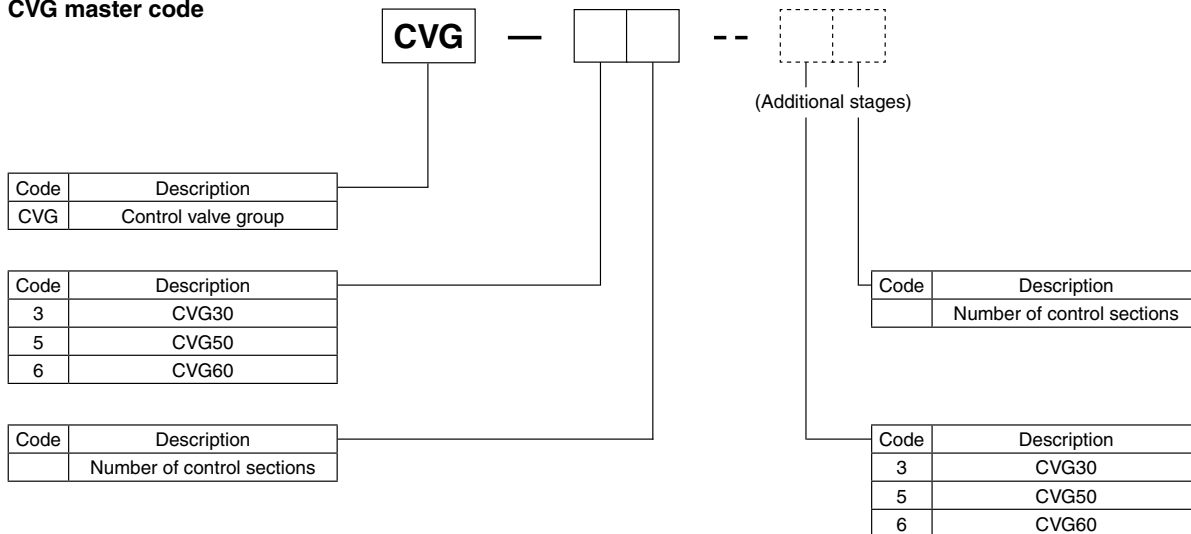

**Example: CVG-51-32**

Inlet with pressure relief valve and pilot oil pressure reducing valve. One CVG50 control section with electro-proportional pilot cover. Adapter to fit two CVG30 control sections and outlet with ports P and T.

**Adjustment values**

Pressure and flow adjustment values of CVG assembly are added after each part item code. Pressure setting of main pressure relief is added after inlet section code. Flow and pressure settings of A and B port is added after control section code.

Qxx = maximum flow setting  
 Axx = maximum supply pressure of port A  
 Bxx = maximum supply pressure of port B

**CVG-51-32 specific order code with pressure and flow settings <sup>1)</sup>.**

1. P50-21-BN2 350
2. S50-81-08-C1-00-F0-BN2 Q800 A350 B280
3. A530-BN2
4. S30-81-05-C1-00-F0-BN2 Q600 A350 B280
5. S30-31-03-C1-00-F0-BN2 Q450 A280 B280
6. T30-12-BN

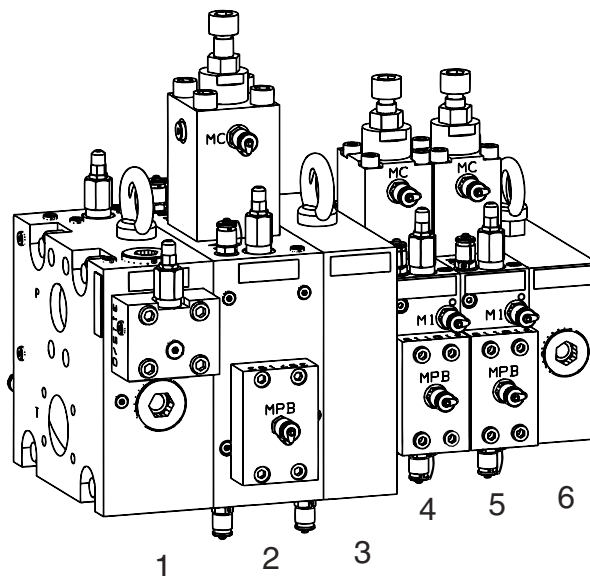

<sup>1)</sup> See specified coding for inlet, control and outlet section from ordering code pages.

**Ordering Code**

**Inlet section**

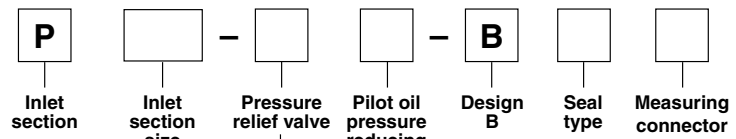

Code	Inlet section size
30	CVG30
50	CVG50
60	CVG60

Code	Pressure relief valve
1	Without pressure relief valve
2	With pressure relief valve

Code	Pilot oil pressure reducing valve
1	With pilot oil pressure reducing valve, internal supply
2	No pilot oil pressure reducing valve, external supply from port PP
3	With pilot oil pressure reducing valve, external supply from port PP2

Code	Seal type
N	NBR
V	FPM

Code	Pressure measuring connector type
2	Carbon steel connector
3	Stainless steel connector

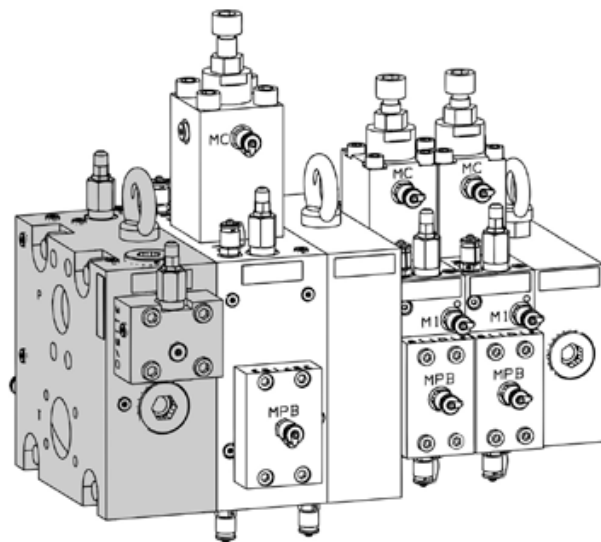

1

**Ordering Code**

**Control section**

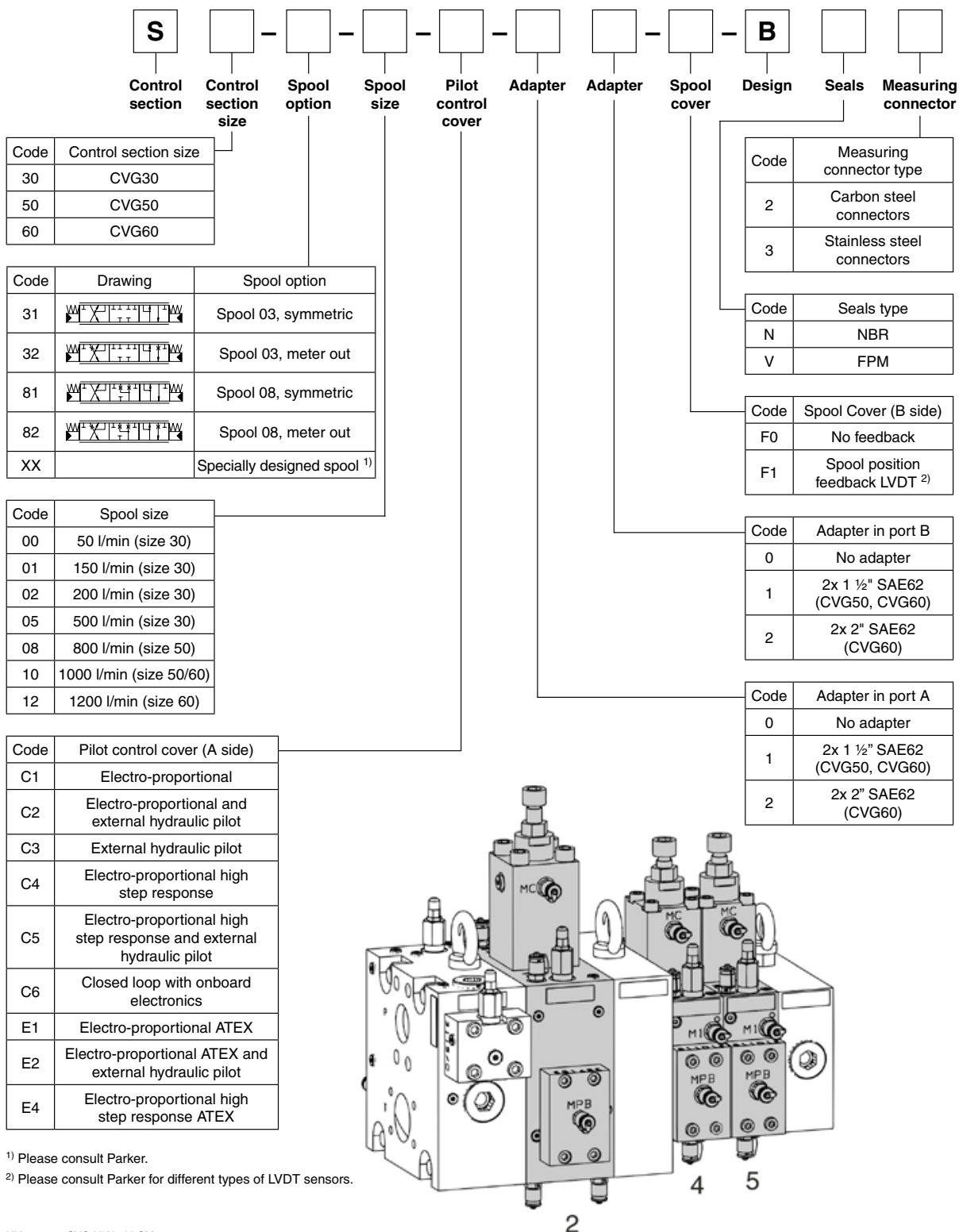

<sup>1)</sup> Please consult Parker.  
<sup>2)</sup> Please consult Parker for different types of LVDT sensors.

**Ordering Code**

**Outlet section**

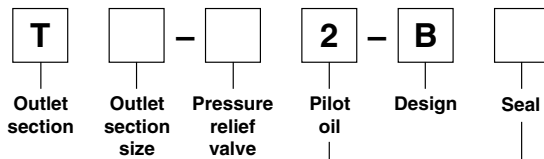

Code	Outlet section size
3	CVG30
5	CVG50
6	CVG60

Code	Pressure relief valve
0	Blind plate. No connections
1	Without pressure relief. Connections P and T
2	With pressure relief valve. Connections P and T

Code	Seal type
N	NBR
V	FPM

Code	Pilot oil pressure reducing valve
2	Without pilot oil pressure reducing valve

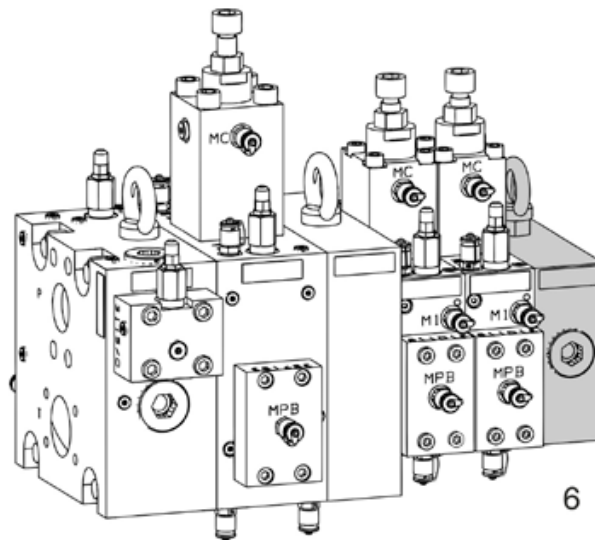

**Ordering Code**

**Adapter section**

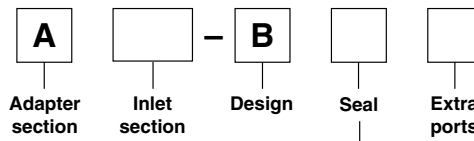

Code	Inlet section size
330	CVG30 to CVG30
530	CVG50 to CVG30
630	CVG60 to CVG30
650	CVG60 to CVG50
550	CVG50 to CVG50

Code	Extra ports
1	No ports
2	Extra ports P, T

Code	Seal type
N	NBR
V	FPM

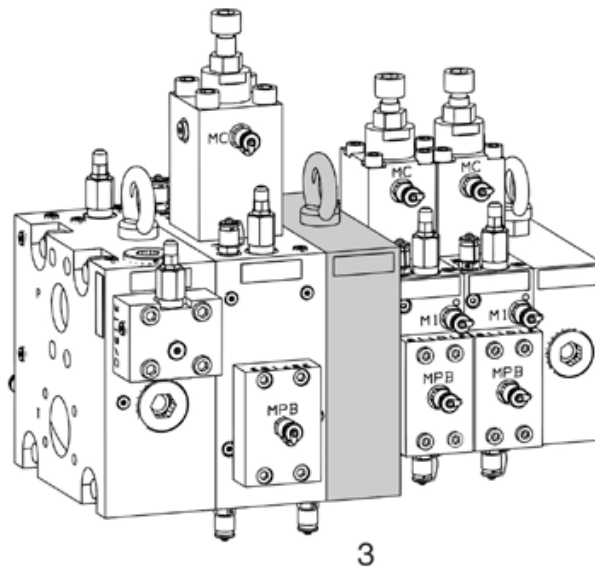

**Measuring Data CVG**

**Pressure drop CVG compensator spools**

The pressure difference over compensator is measured when compensator spool is forced fully open. Pressure is measured from ports MP and M1. Total pressure loss over control section is sum of compensator spool pressure loss and main spool pressure loss.

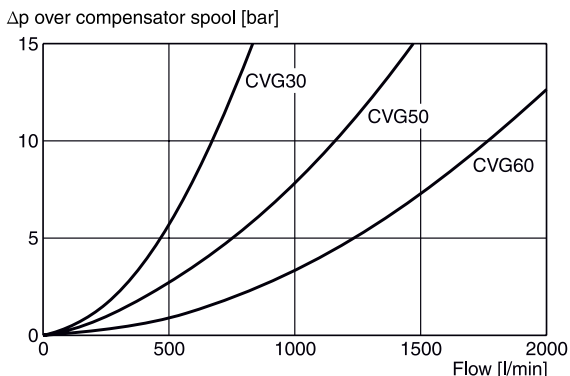

Measured with HLP46 at 50 °C

**CVG30 spool opening vs current**

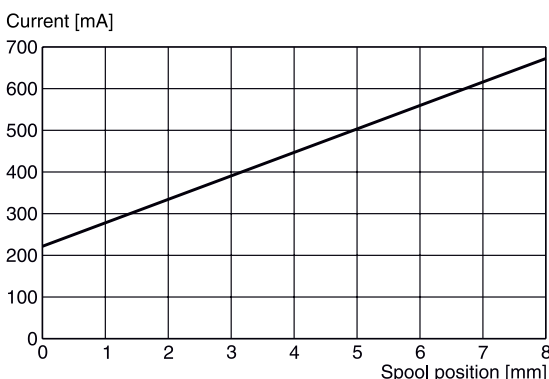

**CVG30 step response**

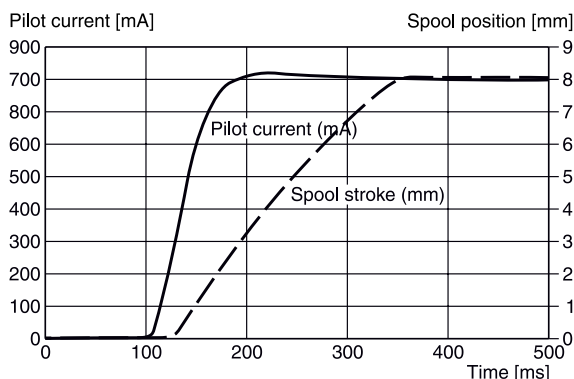

**CVG50/60 spool opening vs current**

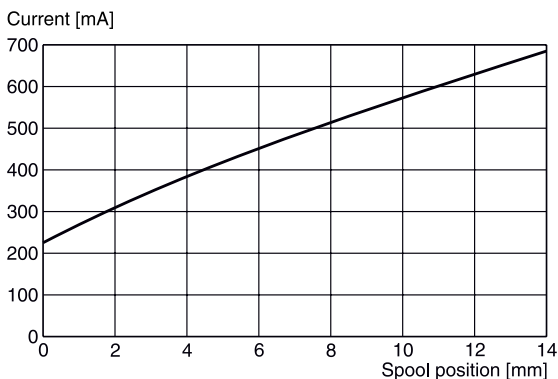

**CVG50/60 step response**

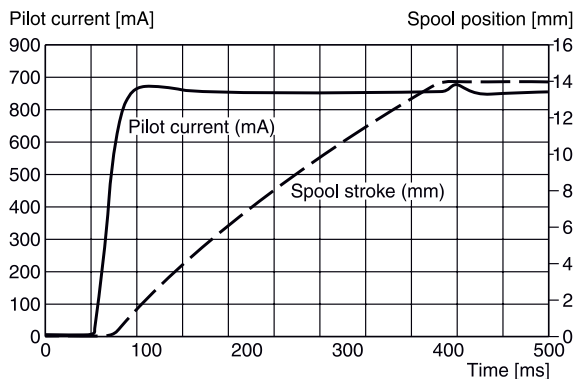

HY11-3353 CVG UK.indd CM 07.10.13



**Measuring Data CVG30**

**Pressure drop CVG30 spools**

The diagram below specifies the pressure loss over spool control edge.

$\Delta p$  over main spool [bar]

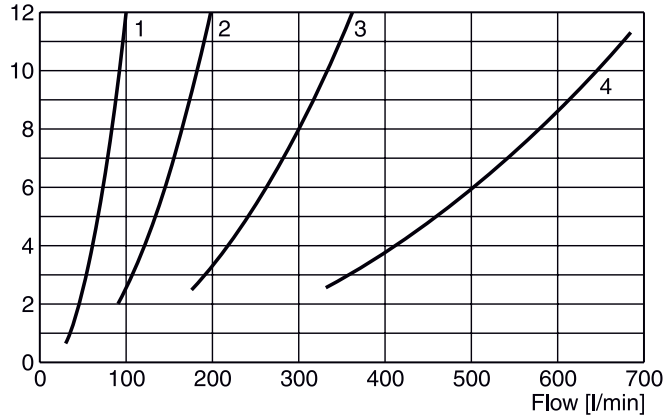

spool	nominal size	Position b		Position a	
		P-B	A-T	P-A	B-T
00	50 l/min (size 30)	1	1	1	1
01	150 l/min (size 30)	2	2	2	2
02	200 l/min (size 30)	3	3	3	3
05	500 l/min (size 30)	4	4	4	4

**Compensator adjustment range CVG30**

The diagram specifies the control curves for spool "81-05"\* with different compensator settings.

Flow [l/min]

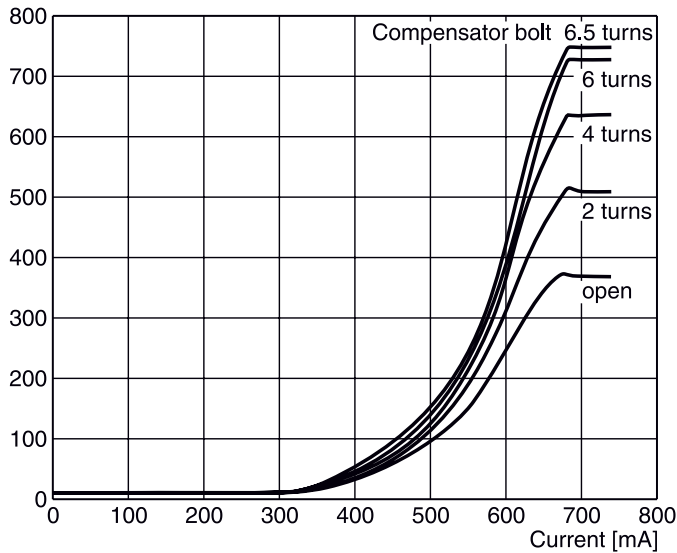

All characteristic curves measured with HLP46 at 50 °C

\* For adjustment range for other spools, please consult Parker.

HY11-3353 CVG UK.indd CM 07.10.13



**Measuring Data CVG50**

**Pressure drop CVG 50 spools**

The diagram below specifies the pressure loss over spool control edge.

$\Delta p$  over main spool [bar]

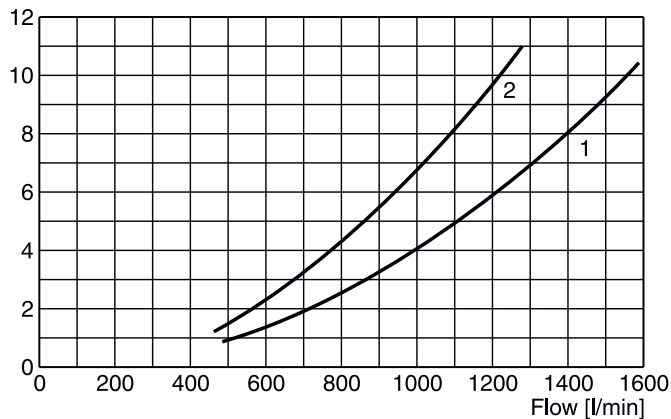

spool	nominal size	Position b		Position a	
		P-B	A-T	P-A	B-T
08	800 l/min (size 50)	1	1	1	1
10	1000 l/min (size 50)	2	2	2	2

**Compensator adjustment range CVG50**

The diagram shows the control curves for spool "81-08\*" with different compensator settings.

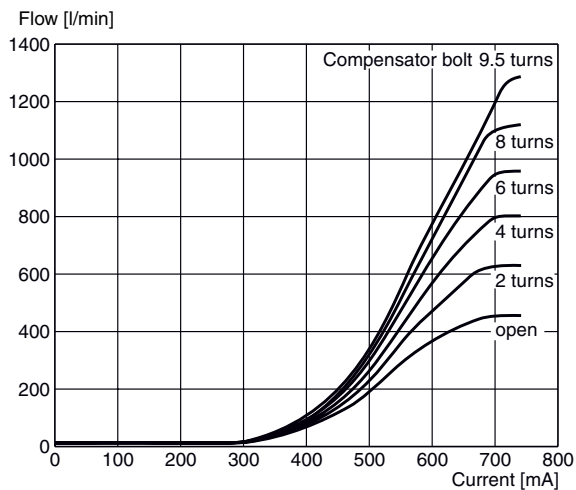

The diagram shows the control curves for spool "81-10\*\*" with different compensator settings.

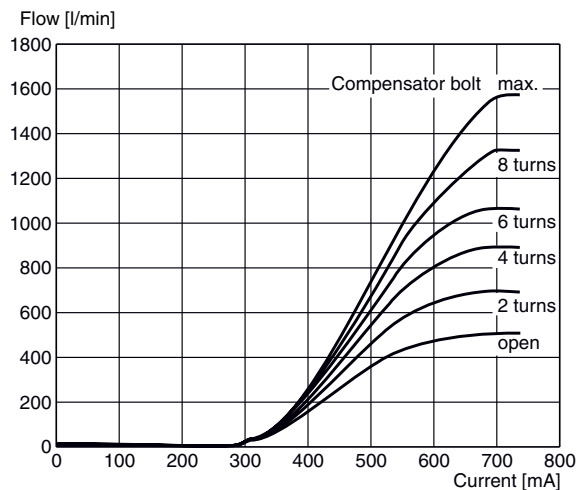

All characteristic curves measured with HLP46 at 50 °C

\* For adjustment range for other spools, please consult Parker.

HY11-3353 CVG UK.indd CM 07.10.13



**Measuring Data CVG60**

**Pressure drop CVG60 spools**

The diagram below specifies the pressure loss over spool control edge.

$\Delta p$  over main spool [bar]

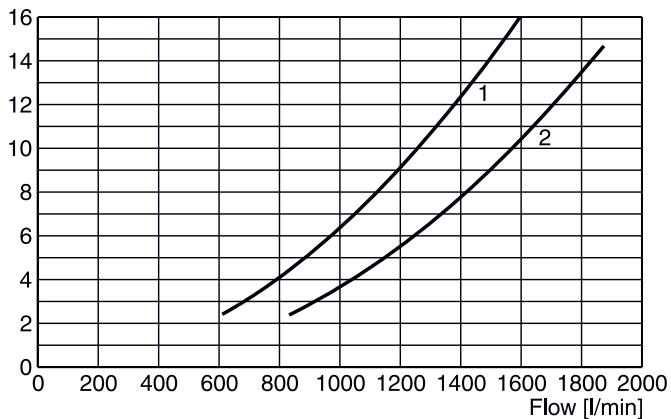

spool	nominal size	Position b		Position a	
		P-B	A-T	P-A	B-T
10	1000 l/min (size 60)	1	1	1	1
12	1200 l/min (size 60)	2	2	2	2

**Compensator adjustment range CVG60**

The diagram shows the control curves for spool "81-12"\* with different compensator settings.

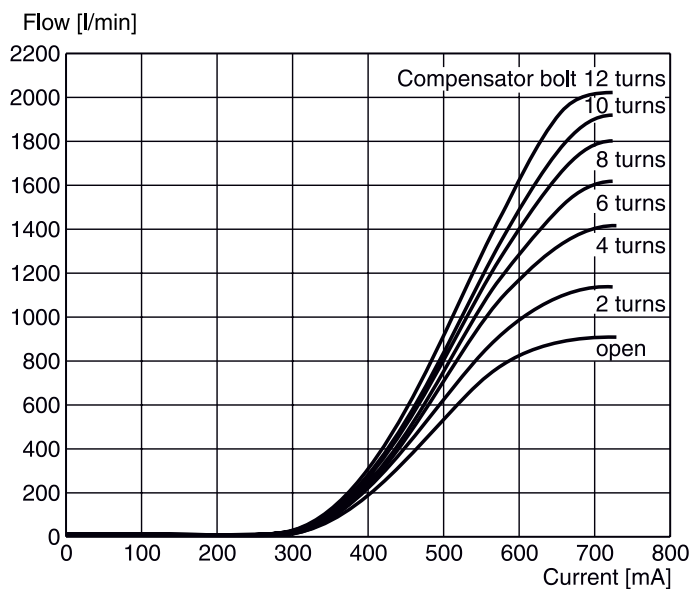

All characteristic curves measured with HLP46 at 50 °C

\* For adjustment range for other spools, please consult Parker.

HY11-3353 CVG UK.indd CM 07.10.13



**Spool Selection Table**
**CVG-B spool table**
**Standard spools**

CVG size	Code	Nominal flow*	Recommended compensator adjustment range [l/min]	Function	Spool assembly part number	Spool part number
CVG30	81-00	60	70 - 110	open center, symmetric	31008702	31013300
CVG30	31-00	60	70 - 110	closed center, symmetric	31008705	31014400
CVG30	81-01	140	130 - 220	open center, symmetric	31008713	31131200
CVG30	31-01	140	130 - 220	closed center, symmetric	31008719	31172100
CVG30	81-02	220	220 - 370	open center, symmetric	31008701	31013200
CVG30	31-02	220	220 - 370	closed center, symmetric	31008704	31014500
CVG30	81-05	500	360 - 750	open center, symmetric	31008700	31011500
CVG30	31-05	500	360 - 750	closed center, symmetric	31008703	31014600
CVG50	81-08	820	600 - 1200	open center, symmetric	31012801	39721200
CVG50	31-08	820	600 - 1200	closed center, symmetric	31012804	31043800
CVG50	81-10	1000	700 - 1400	open center, symmetric	31012800	39721000
CVG50	31-10	1000	700 - 1400	closed center, symmetric	31012803	31036800
CVG60	81-10	950	800 - 1500	open center, symmetric	31012801	39721200
CVG60	31-10	950	800 - 1500	closed center, symmetric	31012804	31043800
CVG60	81-12	1150	1000 - 2000	open center, symmetric	31012800	39721000
CVG60	31-12	1150	1000 - 2000	closed center, symmetric	31012803	31036800

**Meter out spools**

CVG size	Code	Nominal flow*	Recommended compensator adjustment range [l/min]	Function	Spool assembly part number	Spool part number
CVG30	32-02	220	215 - 370	closed center, A-T meter-out 25 %	31008707	31068300
CVG30	32-05	500	360 - 750	closed center, A-T meter-out 25 %	31008706	31063500
CVG50	82-10	1000	700 - 1400	open center, A-T meter-out 25 %	31012808	31086000
CVG50	32-10	1000	700 - 1400	closed center, A-T meter-out 25 %	31012806	31049800
CVG60	82-12	1150	1000 - 2000	open center, A-T meter-out 25 %	31012808	31086000
CVG60	32-12	1150	1000 - 2000	closed center, A-T meter-out 25 %	31012806	31049800

\* l/min at 5 bar over one control edge measured from M1 and MA. Accuracy  $\pm 2\%$ .

**Assembly Diagrams**

**CVG33 assembly example**

The CVG33 assembly includes the inlet section, three control sections and the outlet section. Here is shown one variation of CVG33 assembly with three different types of control sections. The same assembly is shown in the dimensional section of this catalogue.

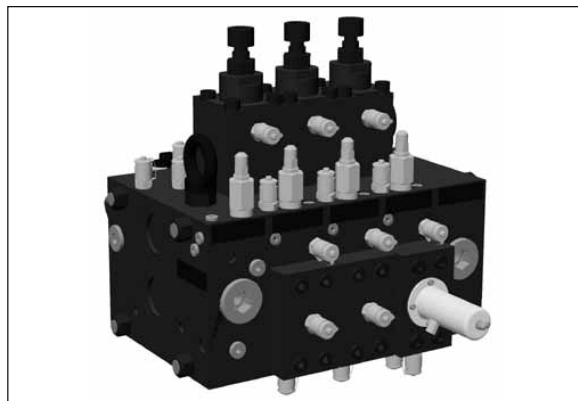

- 1 P30-21-BN2  
Inlet section with pressure relief and pilot pressure valve
- 2 S30-81-05-C1-00-F0-BN2  
Section 1 with electronic spool pilot
- 3 S30-81-05-C2-00-F0-BN2  
Section 2 with electronic and hydraulic spool pilot
- 4 S30-31-05-C3-00-F1-BN2  
Section 3 with hydraulic spool pilot and spool position sensor
- 5 T30-22-BN  
Outlet section with pressure relief

**Hydraulic diagram CVG33**

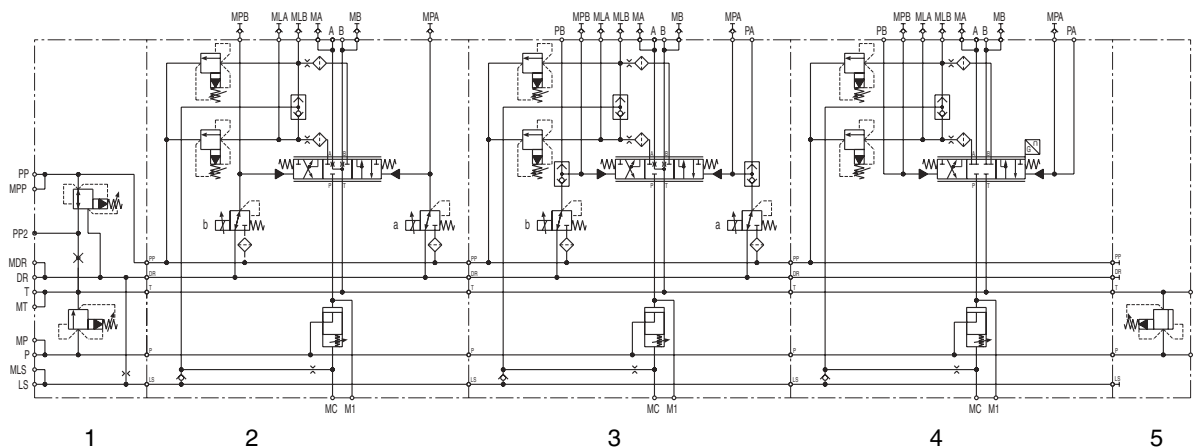

**Assembly Diagrams**

**CVG53 assembly example**

The CVG53 assembly includes the inlet section, three control sections and the outlet section. Here is shown one variation of CVG53 assembly with three different types of control sections. The same assembly is shown in the dimensional section of this catalogue.

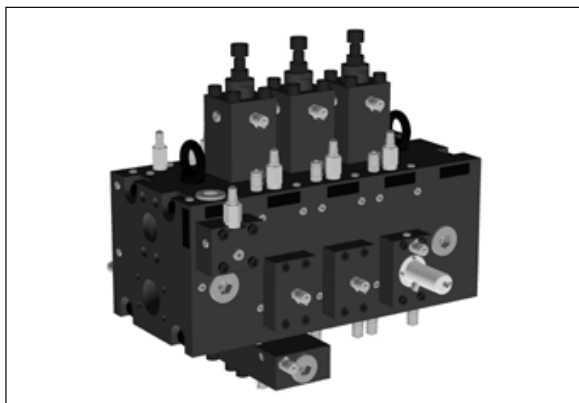

- 1 P50-21-BN2  
Inlet section with pressure relief and pilot pressure valve
- 2 S50-81-08-C1-11-F0-BN2  
Section 1 with electronic spool pilot
- 3 S50-81-08-C2-00-F0-BN2  
Section 2 with electronic and hydraulic spool pilot
- 4 S50-31-08-C3-00-F1-BN2  
Section 3 with hydraulic spool pilot and spool position sensor
- 5 T50-12-BN  
Outlet section without pressure relief

**Hydraulic diagram CVG53**

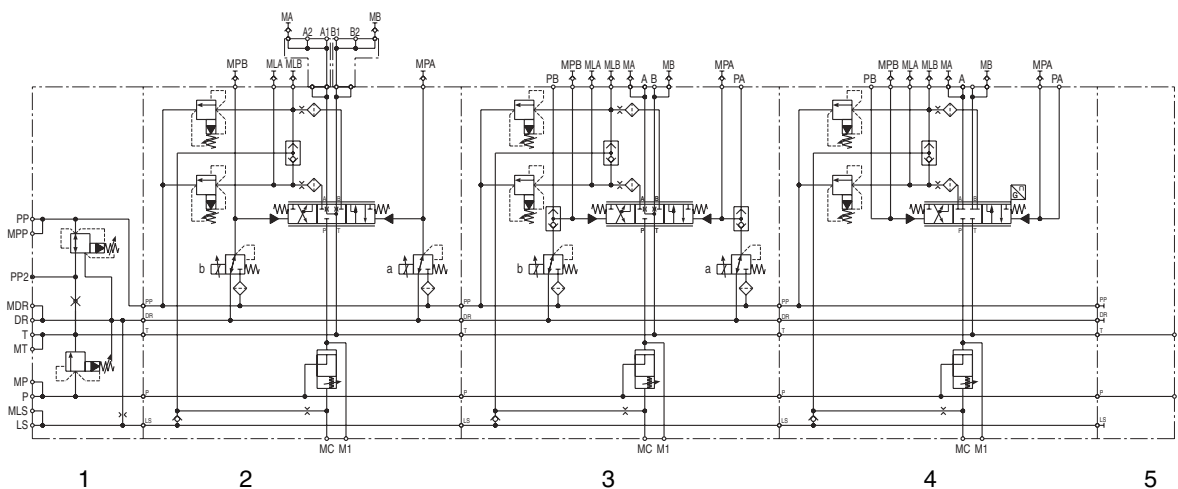

**Assembly Diagrams**

**CVG63 assembly example**

The CVG63 assembly includes the inlet section, three control sections and the outlet section. Here is shown one variation of CVG63 assembly with three different types of control sections. The same assembly is shown in the dimensional section of this catalogue.

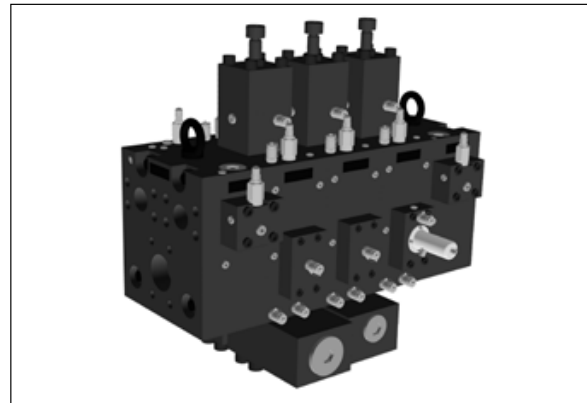

- 1 P60-21-BN  
Inlet section with pressure relief and pilot pressure valve
- 2 S60-81-08-C1-22-F0-BN2  
Section 1 with electronic spool pilot
- 3 S60-81-08-C2-11-F0-BN2  
Section 2 with electronic and hydraulic spool pilot
- 4 S60-31-08-C3-00-F1-BN2  
Section 3 with hydraulic spool pilot and spool position sensor
- 5 T60-22-BN  
Outlet section with pressure relief

**Hydraulic diagram CVG63**

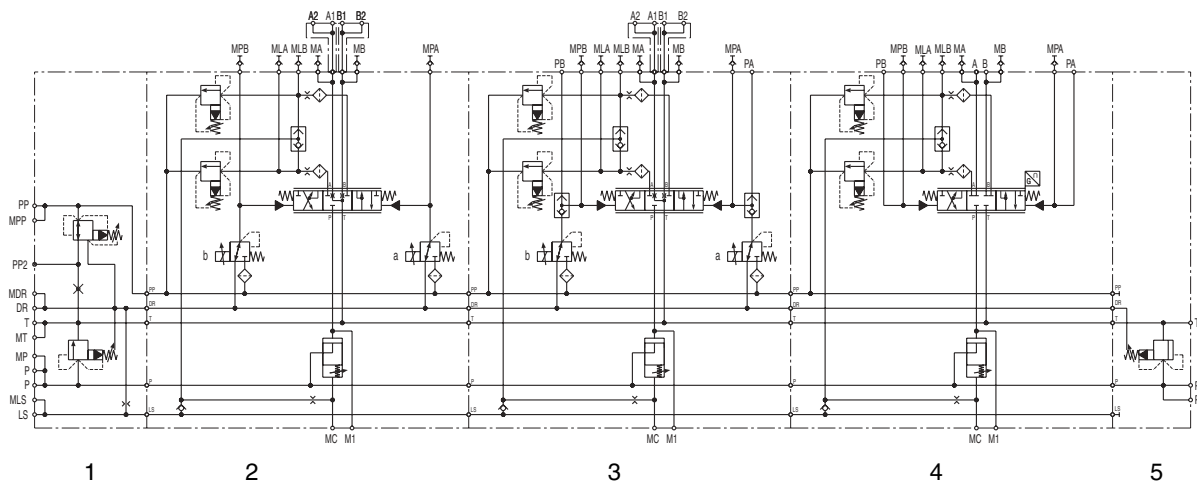

### Dimensions CVG30

### Mobile Directional Control Valve CVG

#### Inlet section connections

P, T	G 1 1/2" BSPP
DR	G 3/8" BSPP
LS, PP, PP2	G 1/4" BSPP
MP, MT, MLS, MPP, MDR	G 1/4" BSPP

#### Outlet section connections

P, T	G 1 1/2" BSPP
------	---------------

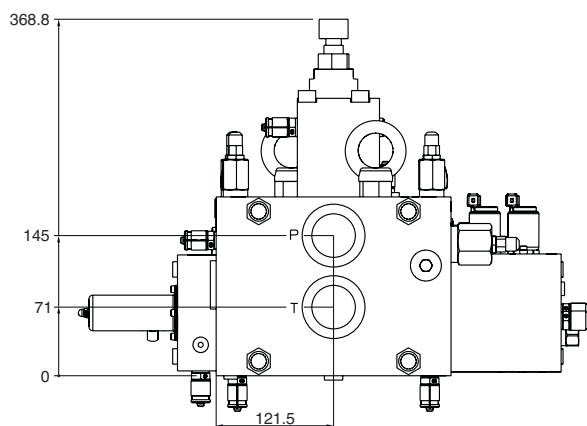
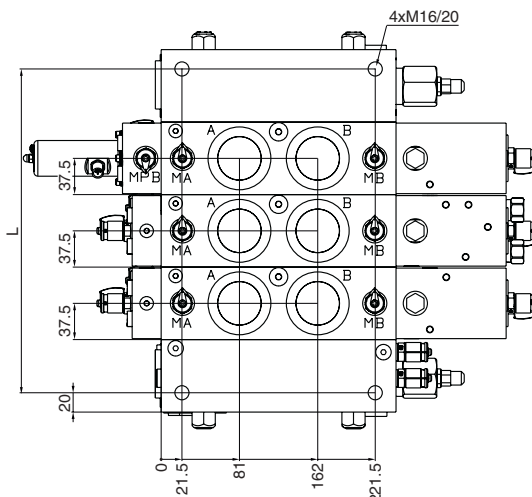
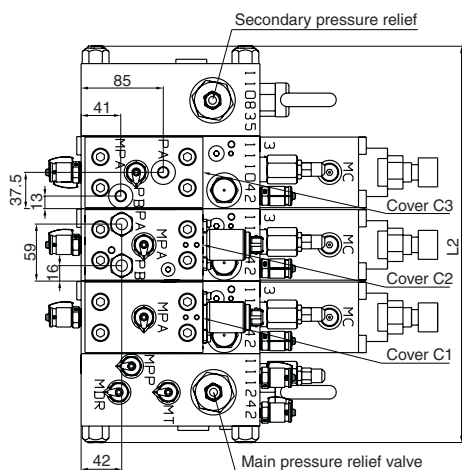
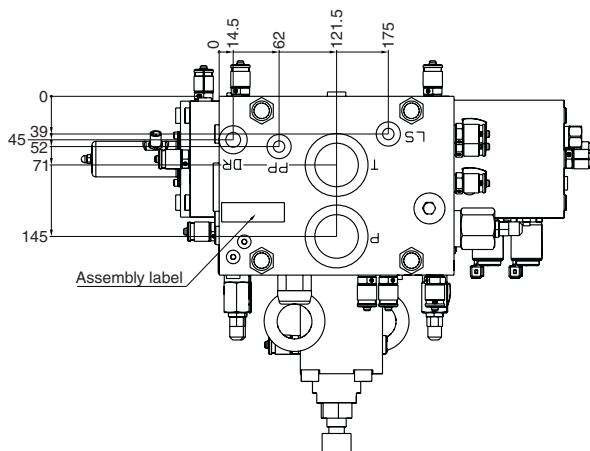

	D1	D2	D3	L1
G 1/8"	8.8	20	10	
G 1/4"	11.8	25	14	
G 3/8"	15.25	29	14	
G 1/2"	19	34	16	
G 3/4"	24.5	42	18	
G 1"	30.5	47	20	
G 1 1/4"	39.5	58	22	
G 1 1/2"	45	65	24	
G 2"	57	76	29	

ISO 228 - G BSPP threads

HY11-3353 CVG UK.indd CM 07.10.13



Catalogue HY11-3353/UK  
**Dimensions CVG30**

**Mobile Directional Control Valve  
 CVG**

**Assembly**

Pos.	Name	Code	Weight (kg)
1	Inlet section	P30-21-BN2	21
2	Control section	S30-81-05-C1-00-F0-BN2	38
3	Control section	S30-81-05-C2-00-F0-BN2	38
4	Control section	S30-31-05-C3-00-F1-BN2	38
5	Outlet section	T30-22-BN	22

**Dimensions**

No. of control sections	L (mm)	L2 (mm)	Weight (kg)
1	225	185	81
2	300	260	119
3	375	295	157
4	450	330	195
5	525	365	233

**Control section connections**

A, B	G 1 1/2" BSPP
MPA, MPB	G 1/4" BSPP
MLA, MLB, M1	G 1/4" BSPP
PA, PB (Cover C2 and C3)	G 1/4" BSPP

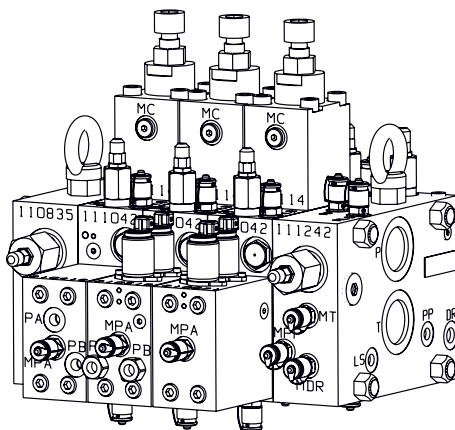
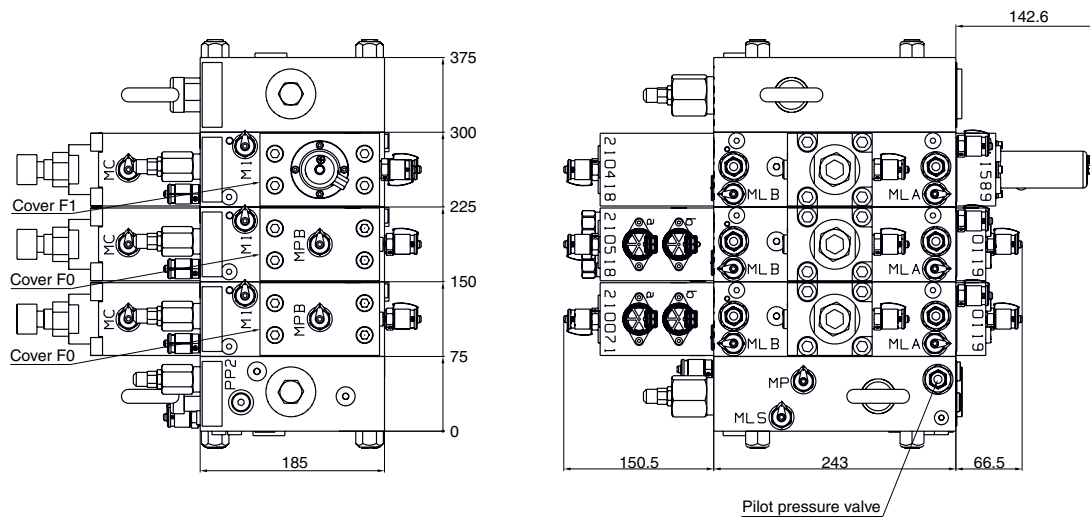

HY11-3353 CVG UK.indd CM 07.10.13



**Dimensions CVG50**

**Inlet section connections**

P	2" SAE62
T	2 1/2" SAE61
DR	G 1/2" BSPP
LS, PP, PP2	G 3/8" BSPP
MP, MT, MLS, MPP, MDR	G 1/4" BSPP

**Outlet section connections**

P	2" SAE62
T	2 1/2" SAE61

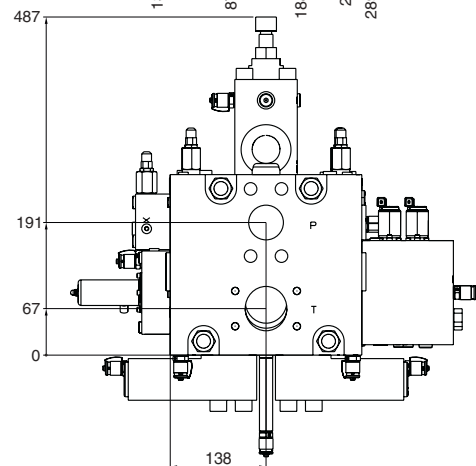
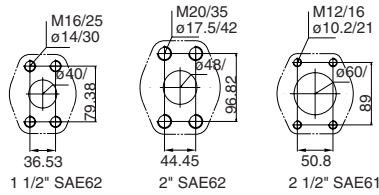
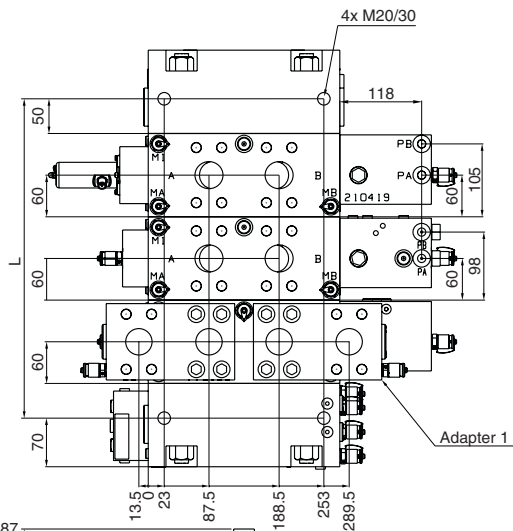
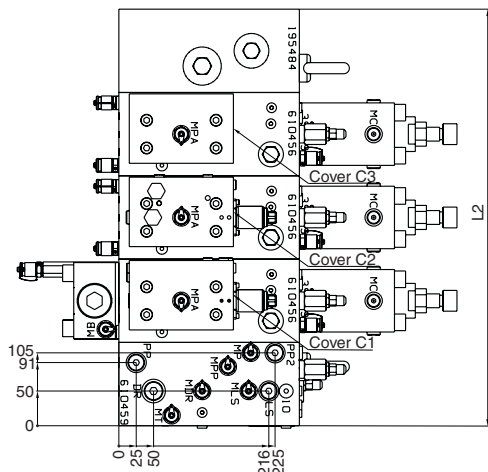
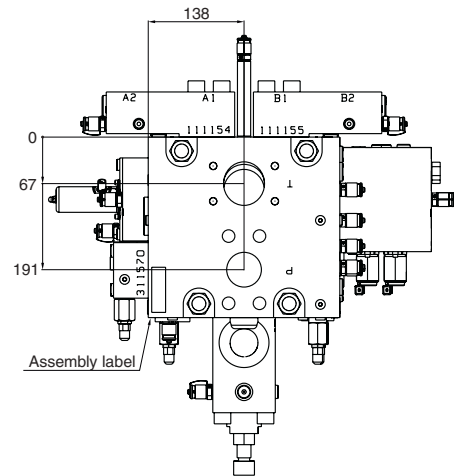

	D1	D2	D3	L1
G 1/8"	8.8	20	10	
G 1/4"	11.8	25	14	
G 3/8"	15.25	29	14	
G 1/2"	19	34	16	
G 3/4"	24.5	42	18	
G 1"	30.5	47	20	
G 1 1/4"	39.5	58	22	
G 1 1/2"	45	65	24	
G 2"	57	76	29	

ISO 228 - G BSPP threads

HY11-3353 CVG UK.indd CM 07.10.13



Catalogue HY11-3353/UK  
**Dimensions CVG50**

**Mobile Directional Control Valve  
 CVG**

**Assembly**

Pos.	Name	Code	Weight (kg)
1	Inlet section	P50-21-BN2	58
2	Control section	S50-81-08-C1-11-F0-BN2	81
3	Control section	S50-81-08-C2-00-F0-BN2	81
4	Control section	S50-31-08-C3-00-F1-BN2	81
5	Outlet section	T50-12-BN	54

**Dimensions**

No. of control sections	L (mm)	L2 (mm)	Weight (kg)
1	220	360	193
2	340	480	274
3	460	600	355
4	580	720	436
5	700	840	517

**Control section connections**

A, B	1 ½" SAE62
MPA, MPB	G ¼" BSPP
MLA, MLB, M1	G ¼" BSPP
PA, PB (Cover C2 and C3)	G ¼" BSPP

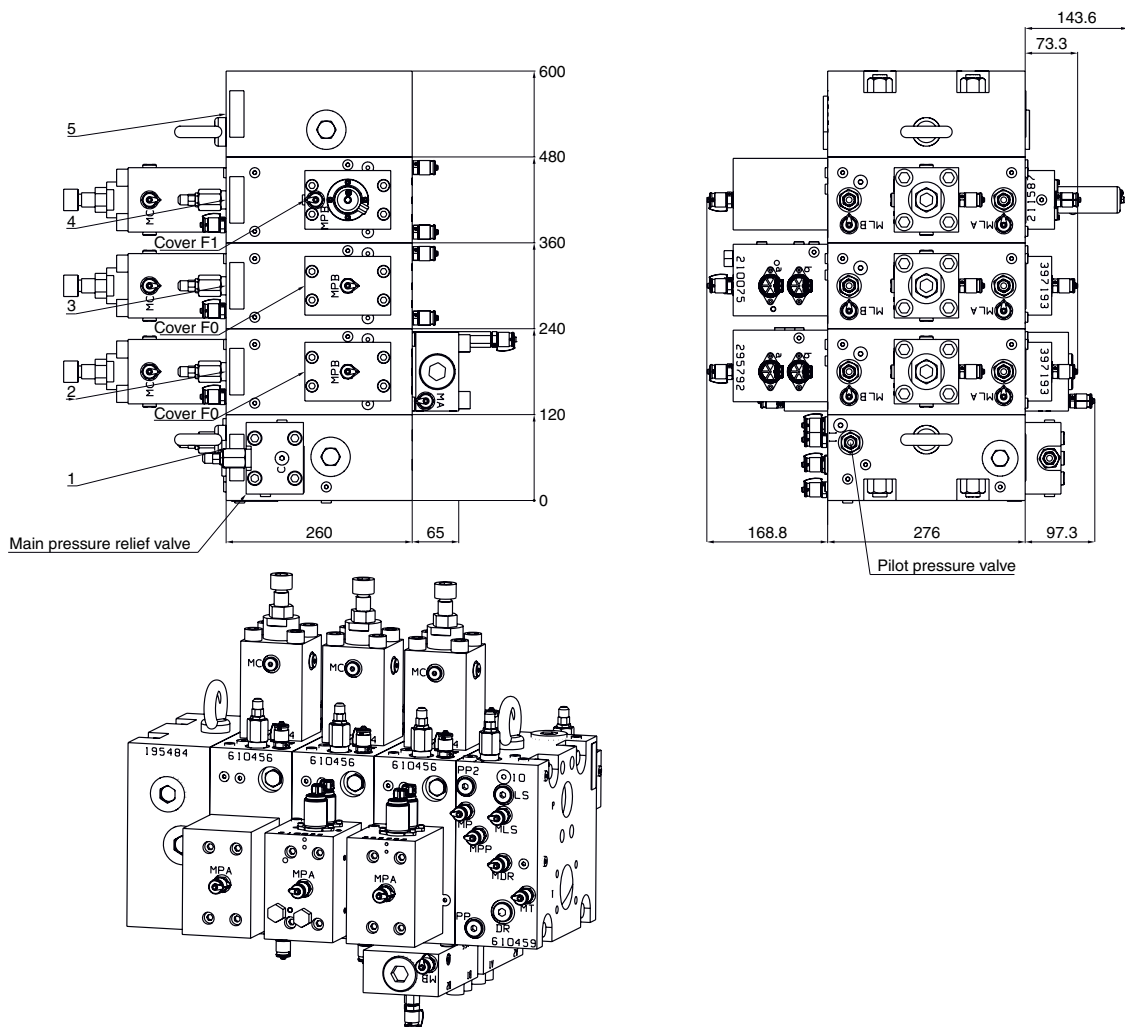

HY11-3353 CVG UK.indd CM 07.10.13



**Dimensions CVG60**

**Inlet section connections**

P	2x 2" SAE62
T	3" SAE61
DR	G 1/2" BSPP
LS, PP, PP2	G 3/8" BSPP
MP, MT, MLS, MPP, MDR	G 1/4" BSPP

**Outlet section connections**

P	2x 2" SAE62
T	3" SAE61

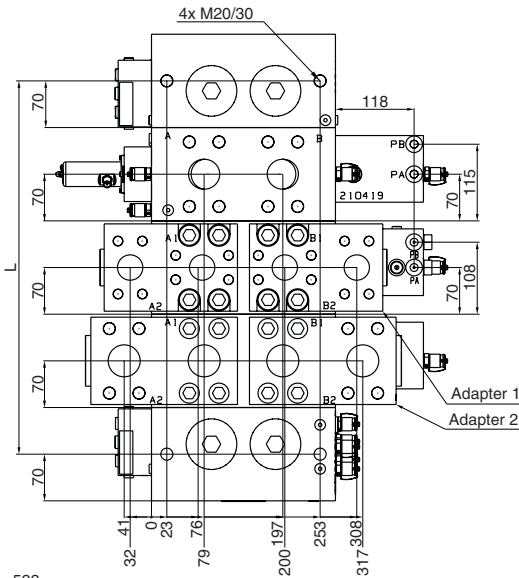
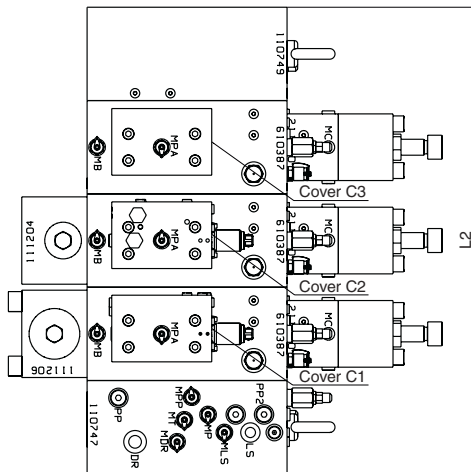
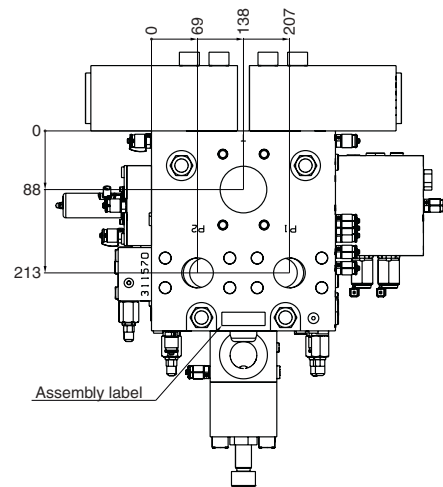

	D1	D2	D3	L1
	G 1/8"	8.8	20	10
	G 1/4"	11.8	25	14
	G 3/8"	15.25	29	14
	G 1/2"	19	34	16
	G 3/4"	24.5	42	18
	G 1"	30.5	47	20
	G 1 1/4"	39.5	58	22
	G 1 1/2"	45	65	24
	G 2"	57	76	29

ISO 228 - G BSPP threads

HY11-3353 CVG UK.indd CM 07.10.13



Catalogue HY11-3353/UK  
**Dimensions CVG60**

**Mobile Directional Control Valve  
 CVG**

**Assembly**

Pos.	Name	Code	Weight
1	Inlet section	P60-21-BN2	79
2	Control section	S60-81-10-C1-22-F0-BN2	135
3	Control section	S60-81-10-C2-11-F0-BN2	131
4	Control section	S60-31-10-C3-00-F1-BN2	97
5	Outlet section	T60-22-BN	54

**Dimensions**

No. of control sections	L (mm)	L2 (mm)	Weight (kg)
1	280	420	250
2	420	560	347
3	560	700	444
4	700	840	541
5	840	980	638

**Control section connections**

A, B	2" SAE62
MPA, MPB	G 1/4" BSPP
MLA, MLB, M1	G 1/4" BSPP
PA, PB (Cover C2 and C3)	G 1/4" BSPP

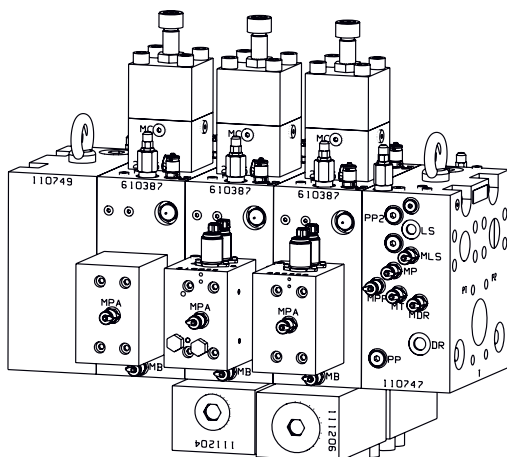
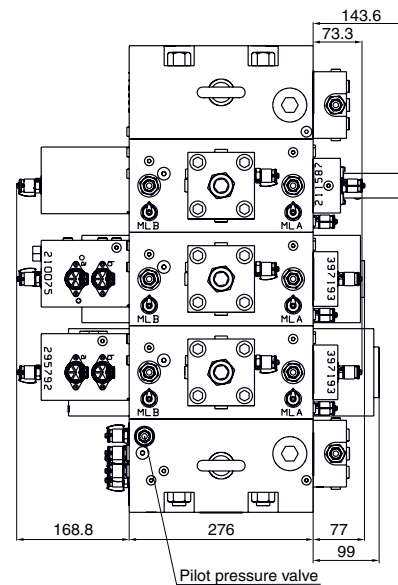
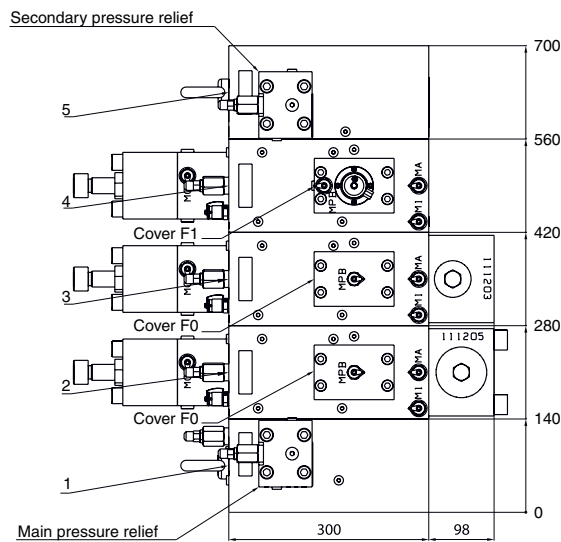

HY11-3353 CVG UK.indd CM 07.10.13



**CVG30 control section**

Position	110829XX		Quantity
	Code	Type	
1	TS110829	SEAL KIT 110829	
2	31013500	CVG30 PILOT COVER ASSEMBLY C1	1
2	31013502	CVG30 PILOT COVER ASSEMBLY C2	1
2	31013502	CVG30 PILOT COVER ASSEMBLY C3	1
3	31013600	CVG30 COVER ASSEMBLY F0	1
4	310087XX	CVG30 SPOOL ASSEMBLY	1
5	31013400	CVG30 COMPENSATOR ASSEMBLY	1
6	PRPA1017	A04G2PZN + CAP 410312	2
7	K02A3N	K02A3N	1
8	VAHA0011	RK1 CHECK VALVE	1
9	KU005200	M5X5-2,0	2
10	PAMA0410	TM85201 24VDC32BAR FILT+OVER	2
11		LVDT ASSEMBLY	1
12	SF438064	SPRING FOR SPOOL	1
13	SF426127	SPRING FOR COMPENSATOR	1
14	41006800	COMPENSATOR SPOOL	1
15	KU006060	M6X6-0,6	1
16	MISTG142	SMK 20-G1/4-VC-V2A<1,4305>AI	8

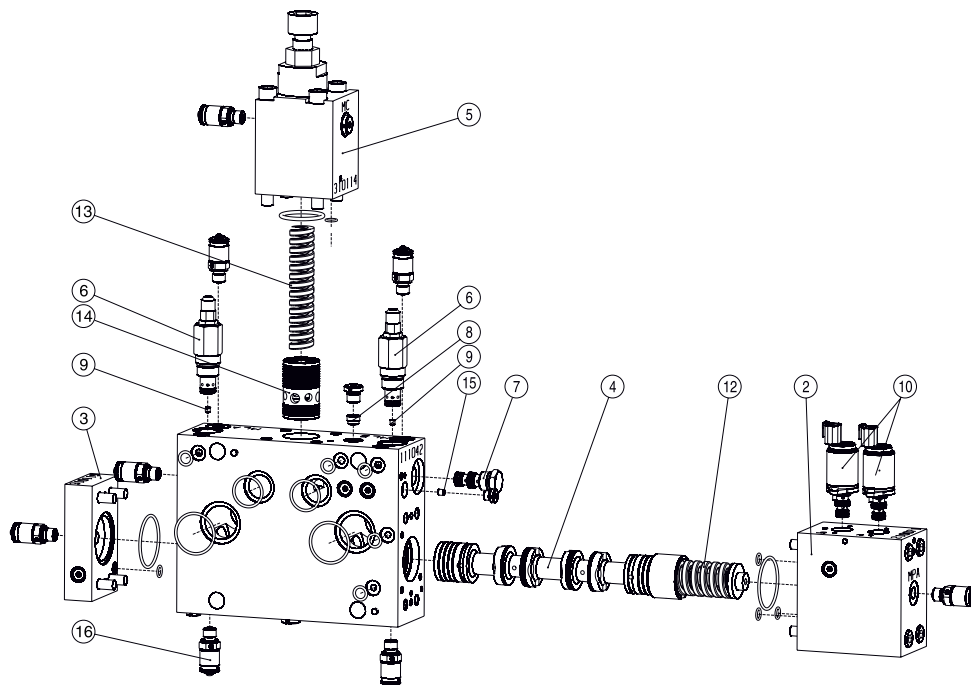

HY11-3353 CVG UK.indd CM 07.10.13



**CVG50 control section**

Position	110842XX		Quantity
	Code	Type	
1	TS110842	SEAL KIT 110842	1
2	31013100	CVG PILOT COVER ASSEMBLY C1	1
2	31013101	CVG PILOT COVER ASSEMBLY C2	1
2	31013102	CVG PILOT COVER ASSEMBLY C3	1
3	31013000	CVG COVER ASSEMBLY F0	1
4	31012800	CVG SPOOL ASSEMBLY	1
5	31012900	CVG50 COMPENSATOR ASSEMBLY	1
6	PRPA1017	A04G2PZN + CAP 410312	2
7	K02A3N	K02A3N	1
8	VAHA0011	RK1 CHECK VALVE	1
9	KU005200	M5X5-2,0	2
10	PAMA0410	TM85201 24VDC32BAR FILT+OVER	2
11		LVDT ASSEMBLY	1
12	SF451001	SPRING FOR SPOOL	1
13	SF432000	SPRING FOR COMPENSATOR	1
14	44289400	COMPENSATOR SPOOL	1
15	KU006080	M6X6-0,8	1
16	EMA3/1/4EDBPCF	EMA3/1/4EDBPCF	8

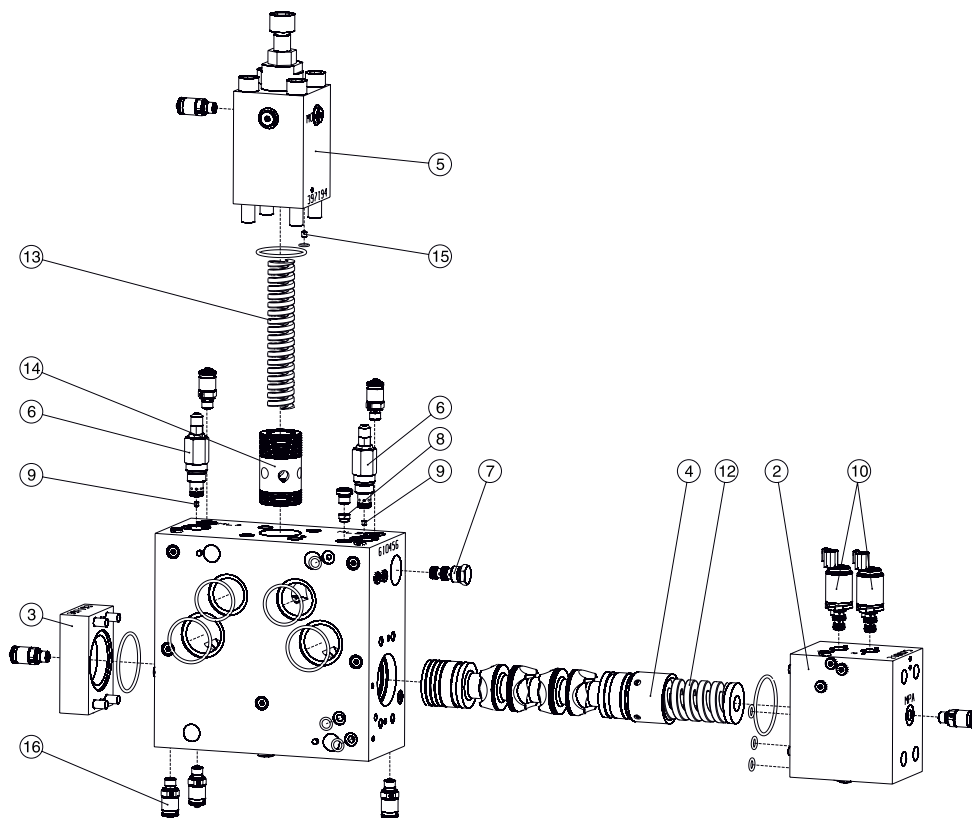

HY11-3353 CVG UK.indd CM 07.10.13

**CVG60 control section**

Position	110734XX		Quantity
	Code	Type	
1	TS 110734	SEAL KIT 110734	
2	31013100	CVG PILOT COVER ASSEMBLY C1	1
2	31013101	CVG PILOT COVER ASSEMBLY C2	1
2	31013102	CVG PILOT COVER ASSEMBLY C3	1
3	31013000	CVG COVER ASSEMBLY F0	1
4	31012800	CVG SPOOL ASSEMBLY	1
5	31178700	CVG60 COMPENSATOR ASSEMBLY	1
6	PRPA1017	A04G2PZN + CAP 410312	2
7	K02A3N	K02A3N	1
8	VAHA0011	RK1 CHECK VALVE	1
9	KU005200	M5X5-2,0	2
10	PAMA0410	TM85201 24VDC32BAR FILT+OVER	2
11		LVDT ASSEMBLY	1
12	SF451001	SPRING FOR SPOOL	1
13	SF432000	SPRING FOR COMPENSATOR	1
14	44289400	COMPENSATOR SPOOL	1
15	KU006080	M6X6-0,8	1
16	EMA3/1/4EDBPCF	EMA3/1/4EDBPCF	8

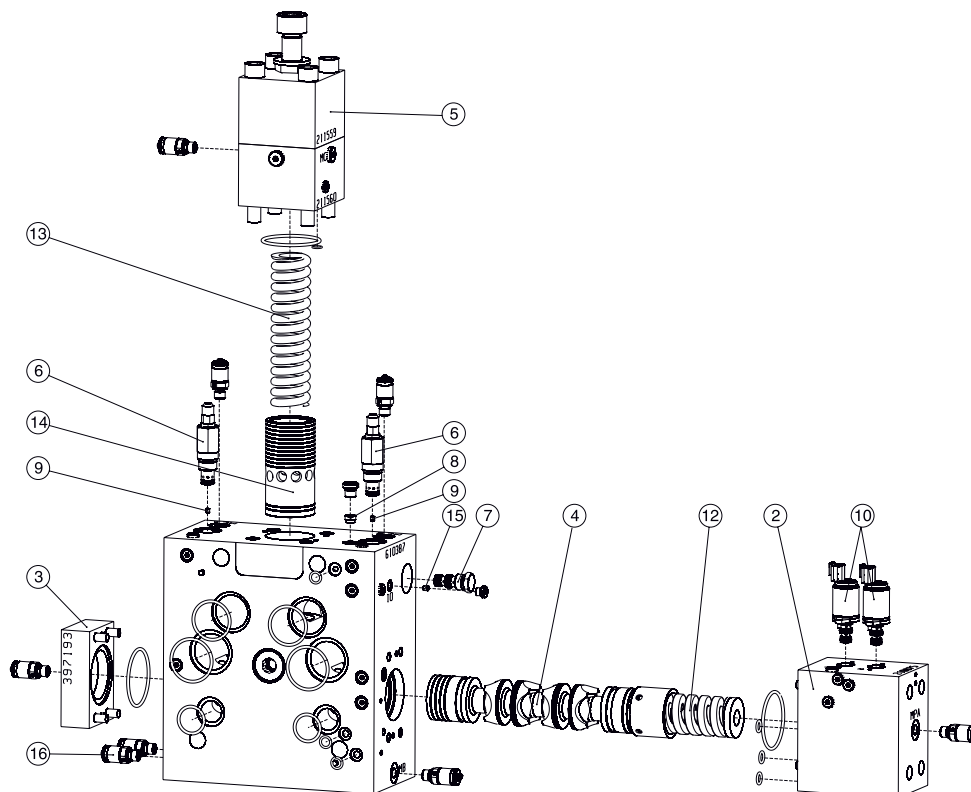

HY11-3353 CVG UK.indd CM 07.10.13



**Spare Parts**

**CVG30 Inlet section with pressure relief**

Position	211545XX		Quantity
	Code	Type	
1	TS211545	SEAL KIT 211545	1
2	PRPA2505	A06G2PZN + CAP 410312	1
3	PAPA1038	C04B3HZN + CAP 410312	1
4	KU006040	M6X6-0,4	
5	EMA3/1/4EDBPCF	EMA3/1/4EDBPCF	5

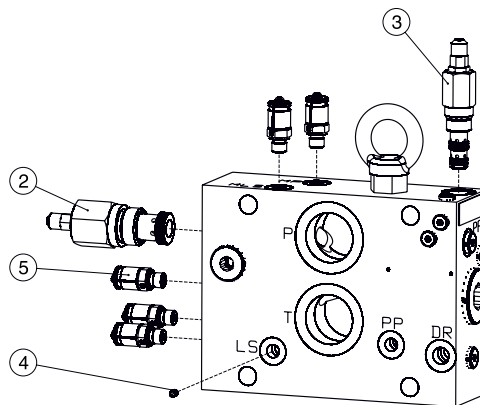

**Spare Parts**

**CVG50 Inlet section with pressure relief**

Position	211080XX		Quantity
	Code	Type	
1	TS211080	SEAL KIT 211080	1
2	31156900	CRL40 R6S AN X12C10	1
3	41003802	CEL40 A40 AN 00	1
4	PAPA1038	C04B3HZN + CAP 410312	1
5	KU006040	M6X6-0,4	1
6	EMA3/1/4EDBPCF	EMA3/1/4EDBPCF	5

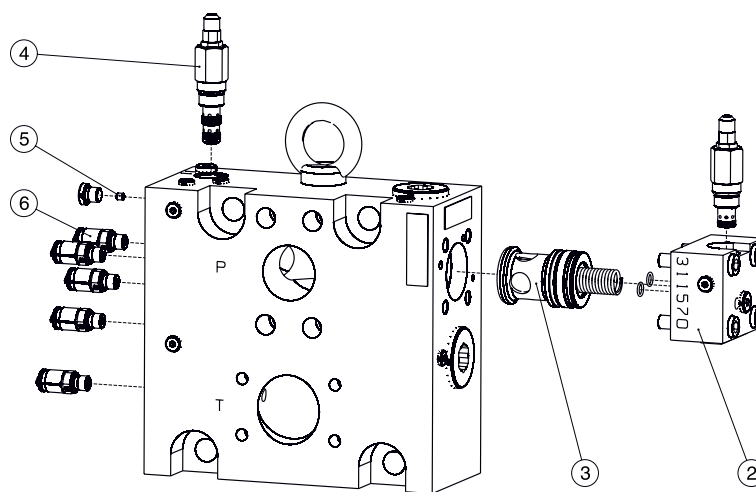

**Spare Parts**

**CVG60 Inlet section with pressure relief**

Position	210938XX		Quantity
	Code	Type	
1	TS210938	SEAL KIT 210938	1
2	31156900	CRL40 R6S AN X12C10	1
3	41003802	CEL40 A40 AN 00	1
4	PAPA1038	C04B3HZN + CAP 410312	1
5	KU006040	M6X6-0,4	1
6	EMA3/1/4EDBPCF	EMA3/1/4EDBPCF	5

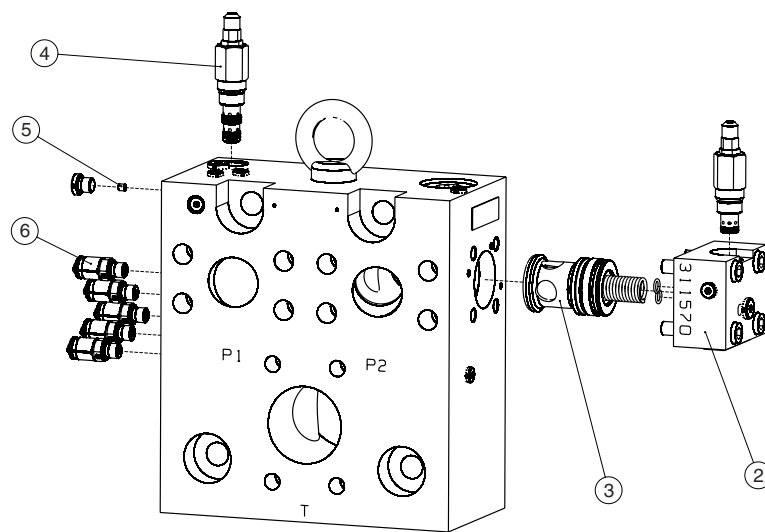

**Spare Parts**

**Adapters**

	211350XX	Adapter A650	1
1	TS211350	SEAL KIT 211350	

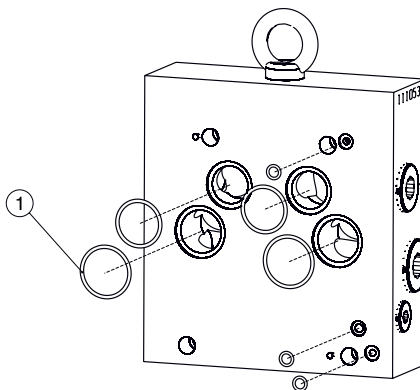

	111198XX	Adapter A630	1
1	TS111198	SEAL KIT 111198	

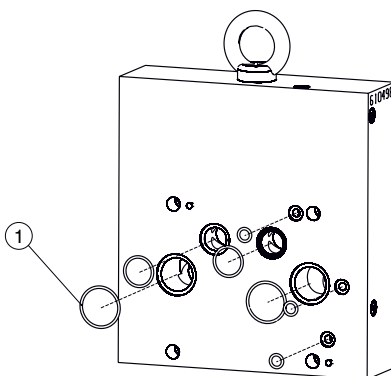

	211351XX	Adapter A530	1
1	TS211351	SEAL KIT 211351	

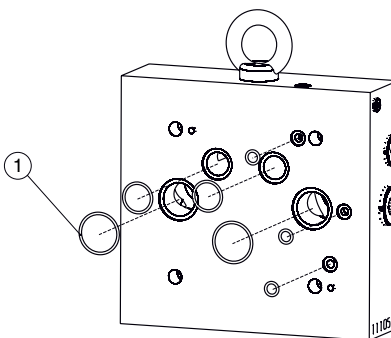

HY11-3353 CVG UK.indd CM 07.10.13









## Parker Worldwide

### Europe, Middle East, Africa

**AE – United Arab Emirates,** Dubai  
Tel: +971 4 8127100  
parker.me@parker.com

**AT – Austria,** Wiener Neustadt  
Tel: +43 (0)2622 23501-0  
parker.austria@parker.com

**AT – Eastern Europe,** Wiener Neustadt  
Tel: +43 (0)2622 23501 900  
parker.easteurope@parker.com

**AZ – Azerbaijan,** Baku  
Tel: +994 50 22 33 458  
parker.azerbaijan@parker.com

**BE/LU – Belgium,** Nivelles  
Tel: +32 (0)67 280 900  
parker.belgium@parker.com

**BG – Bulgaria,** Sofia  
Tel: +359 2 980 1344  
parker.bulgaria@parker.com

**BY – Belarus,** Minsk  
Tel: +375 17 209 9399  
parker.belarus@parker.com

**CH – Switzerland,** Etoy  
Tel: +41 (0)21 821 87 00  
parker.switzerland@parker.com

**CZ – Czech Republic,** Klecany  
Tel: +420 284 083 111  
parker.czechrepublic@parker.com

**DE – Germany,** Kaarst  
Tel: +49 (0)2131 4016 0  
parker.germany@parker.com

**DK – Denmark,** Ballerup  
Tel: +45 43 56 04 00  
parker.denmark@parker.com

**ES – Spain,** Madrid  
Tel: +34 902 330 001  
parker.spain@parker.com

**FI – Finland,** Vantaa  
Tel: +358 (0)20 753 2500  
parker.finland@parker.com

**FR – France,** Contamine s/Arve  
Tel: +33 (0)4 50 25 80 25  
parker.france@parker.com

**GR – Greece,** Athens  
Tel: +30 210 933 6450  
parker.greece@parker.com

**HU – Hungary,** Budaoers  
Tel: +36 23 885 470  
parker.hungary@parker.com

**IE – Ireland,** Dublin  
Tel: +353 (0)1 466 6370  
parker.ireland@parker.com

**IT – Italy,** Corsico (MI)  
Tel: +39 02 45 19 21  
parker.italy@parker.com

**KZ – Kazakhstan,** Almaty  
Tel: +7 7273 561 000  
parker.easteurope@parker.com

**NL – The Netherlands,** Oldenzaal  
Tel: +31 (0)541 585 000  
parker.nl@parker.com

**NO – Norway,** Asker  
Tel: +47 66 75 34 00  
parker.norway@parker.com

**PL – Poland,** Warsaw  
Tel: +48 (0)22 573 24 00  
parker.poland@parker.com

**PT – Portugal,** Leca da Palmeira  
Tel: +351 22 999 7360  
parker.portugal@parker.com

**RO – Romania,** Bucharest  
Tel: +40 21 252 1382  
parker.romania@parker.com

**RU – Russia,** Moscow  
Tel: +7 495 645-2156  
parker.russia@parker.com

**SE – Sweden,** Spånga  
Tel: +46 (0)8 59 79 50 00  
parker.sweden@parker.com

**SK – Slovakia,** Banská Bystrica  
Tel: +421 484 162 252  
parker.slovakia@parker.com

**SL – Slovenia,** Novo Mesto  
Tel: +386 7 337 6650  
parker.slovenia@parker.com

**TR – Turkey,** Istanbul  
Tel: +90 216 4997081  
parker.turkey@parker.com

**UA – Ukraine,** Kiev  
Tel: +380 44 494 2731  
parker.ukraine@parker.com

**UK – United Kingdom,** Warwick  
Tel: +44 (0)1926 317 878  
parker.uk@parker.com

**ZA – South Africa,** Kempton Park  
Tel: +27 (0)11 961 0700  
parker.southafrica@parker.com

### North America

**CA – Canada,** Milton, Ontario  
Tel: +1 905 693 3000

**US – USA,** Cleveland (industrial)  
Tel: +1 216 896 3000

**US – USA,** Elk Grove Village (mobile)  
Tel: +1 847 258 6200

### Asia Pacific

**AU – Australia,** Castle Hill  
Tel: +61 (0)2-9634 7777

**CN – China,** Shanghai  
Tel: +86 21 2899 5000

**HK – Hong Kong**  
Tel: +852 2428 8008

**ID – Indonesia,** Tangerang  
Tel: +62 21 7588 1906

**IN – India,** Mumbai  
Tel: +91 22 6513 7081-85

**JP – Japan,** Fujisawa  
Tel: +81 (0)4 6635 3050

**KR – South Korea,** Seoul  
Tel: +82 2 559 0400

**MY – Malaysia,** Shah Alam  
Tel: +60 3 7849 0800

**NZ – New Zealand,** Mt Wellington  
Tel: +64 9 574 1744

**SG – Singapore**  
Tel: +65 6887 6300

**TH – Thailand,** Bangkok  
Tel: +662 717 8140

**TW – Taiwan,** New Taipei City  
Tel: +886 2 2298 8987

**VN – Vietnam,** Ho Chi Minh City  
Tel: +84 8 3999 1600

### South America

**AR – Argentina,** Buenos Aires  
Tel: +54 3327 44 4129

**BR – Brazil,** Cachoeirinha RS  
Tel: +55 51 3470 9144

**CL – Chile,** Santiago  
Tel: +56 2 623 1216

**MX – Mexico,** Toluca  
Tel: +52 72 2275 4200



#### EMEA Product Information Centre

Free phone: 00 800 27 27 5374

(from AT, BE, CH, CZ, DE, DK, EE, ES, FI, FR, IE, IL, IS, IT, LU, MT, NL, NO, PL, PT, RU, SE, SK, UK, ZA)

#### US Product Information Centre

Toll-free number: 1-800-27 27 537

[www.parker.com](http://www.parker.com)

Your local authorized Parker distributor