

Global FRL and P3Y Series Air Preparation System

Modular 1/4" to 3/4"

Body Ported 3/4" & 1", with port Blocks 1.1/4" & 1.1/2"

Catalogue no. PDE2676TCUK June 2021



ENGINEERING YOUR SUCCESS.

PDE2676TCUK

Global FRL and P3Y Series



DECLARATION OF COMPLIANCE (ROHS)

European Directive 2011/65/EU – RoHS (Restriction of certain Hazardous Substances in electrical and electronic equipment), restricts the use of the 6 substances in the manufacture of specified electrical equipment.

Lead: Product containing lead and its compound (except for applications of lead as an alloying element by weight in steel up to 0.35%, in aluminium up to 0.4% and in copper alloys up to 4% and in circuit board solder) must not exceed 0.1% by weight

Mercury: The concentration level must not exceed 0.1% by volume

Cadmium: The concentration level must not exceed 0.01% by volume

Hexavalent Chromium:

This is a corrosive protective finish used on our product line. Where this finish is utilized the Chromate solution is Hexavalent (Chrome 6) free.

Polybrominated Biphenyls (PBB):

The concentration level must not exceed 0.1% by weight. This substance is not known to be in any of our products.

Polybrominated Diphenyl Esters (PBDE):

The concentration level must not exceed 0.1% by weight. This substance is not known to be in any of our products.



Following Ignition Hazard Assessments performed on the non-electrical Global Air Preparation products they are in accordance with the requirements of EN 13463-1:2009, it was considered that the equipment does not contain its own source of ignition, and therefore is not within the scope of directive 94/9/EC.

The products can be used in a Group II Category 2 environment assuming that the ATEX Directive and the following conditions are complied with:

- Installation and maintenance of the product must be undertaken by qualified personnel.
- Do not mount the products in an area where impact may occur.
- Filters must be used to limit the introduction of particles and to capture particles generated in service.
- Supply air quality must be within ISO 8573-1:2010 Class 6.4.4.
- Maximum working temperature to be as stated on product label.
- **WARNING** – pulsating pressure and/or a closed circuit can generate heat.
- Deposits of dust on the product must not exceed 5mm thickness. Refer to technical file for surface areas of plastics. The unit must be earthed via the compressed air supply line.
- The unit must not come into contact with liquid solvents, acids or alkalis. Refer to technical file for chemicals known to be incompatible. Product cleaning must be undertaken using a method complying with the specifications of the ATEX zone, preferably by using mild soap and water or antistatic products.
- **Regulators, Filter Regulators:**
Do not use Regulators or Filter Regulators within systems that can create vibration within the Regulator / Filter Regulator unit.
- **Solenoid Operated Valves:**
Are suitable for use in an ATEX environment, (Group II Category 2) providing ATEX approved solenoids are fitted.
- Technical file available on request.



Global Air Preparation products supplied by Parker Hannifin have been designed and manufactured in accordance with "sound engineering practice", as defined by Article 3 of Pressure Equipment Directive 97/23/EC.



Global Air Preparation product range is in compliance with REACH to ensure continued compliance additions to the list of SVHC (Substance of Very High Concern) are reviewed periodically.

Global Air Preparation product range has been third party Shock & Vibration tested independently in accordance to EN 61373 : 1999, Category 2



Global Air Preparation product range has been designed and tested in accordance with ISO flow testing, envelope integrity, and catalog data presented.

- Filters – ISO 5782-1 & ISO 5782-2: 1997
- Regulators- ISO 6953-1 & ISO 6953-2: 2000
- Lubricators- ISO 6301-1 & ISO 6301-2: 2009



FAILURE OR IMPROPER SELECTION OR IMPROPER USE OF THE PRODUCTS AND/OR SYSTEMS DESCRIBED HEREIN OR RELATED ITEMS CAN CAUSE DEATH, PERSONAL INJURY AND PROPERTY DAMAGE.

This document and other information from Parker Hannifin Corporation, its subsidiaries and authorized distributors provide product and/or system options for further investigation by users having technical expertise. It is important that you analyze all aspects of your application including consequences of any failure, and review the information concerning the product or system in the current product catalog. Due to the variety of operating conditions and applications for these products or systems, the user, through its own analysis and testing, is solely responsible for making the final selection of the products and systems and assuring that all performance, safety and warning requirements of the application are met.

The products described herein, including without limitation, product features, specifications, designs, availability and pricing, are subject to change by Parker Hannifin Corporation and its subsidiaries at any time without notice.

Offer of Sale

The items described in this document are hereby offered for sale by Parker Hannifin Corporation, its subsidiaries or its authorized distributors. This offer and its acceptance are governed by the provisions stated on the separate page of this document entitled "Offer of Sale".

© Copyright 2020, 2014, 2012, 2010 Parker Hannifin Corporation. All Rights Reserved



Introduction	4 - 9
P31, P32, P33 Series	10 - 80
Global System	10 - 13
Particulate Filters	14 - 19
Coalescing Filters	20 - 25
Regulators	26 - 37
Proportional Regulators	38 - 41
Filter / Regulators	42 - 49
Lubricators	50 - 55
Combinations	56 - 59
Dump Valves / Soft Start Valves	60 - 65
Safety Exhaust Valves	66 - 69
Accessories	70 - 80
P3Y Series	81 - 105
P3Y System	81
Particulate Filters	82 - 83
Coalescing Filters	84 - 85
Regulators	86 - 89
Proportional Pressure Regulators	90 - 91
Filter / Regulators	92 - 93
Lubricators	94 - 95
Combinations	96 - 97
Soft Start / Dump Valves	98 - 101
Accessories	102 - 105
Safety Guide	106



Parker Global Air Preparation System

Global.
Modular.



Performance you need,
wherever you need it.

Full featured particulate and coalescing filters, regulators, filter/regulators, and lubricators are available with a wide range of standard options to meet air preparation needs.

The comprehensive Global Air Preparation System is available in three body sizes with either BSPP (EMEA) or NPT (US) to accommodate thread type requirements.

Individual units can easily be assembled into various combinations, utilizing patented modular lightweight body connectors.

Fully Modular Air Preparation System

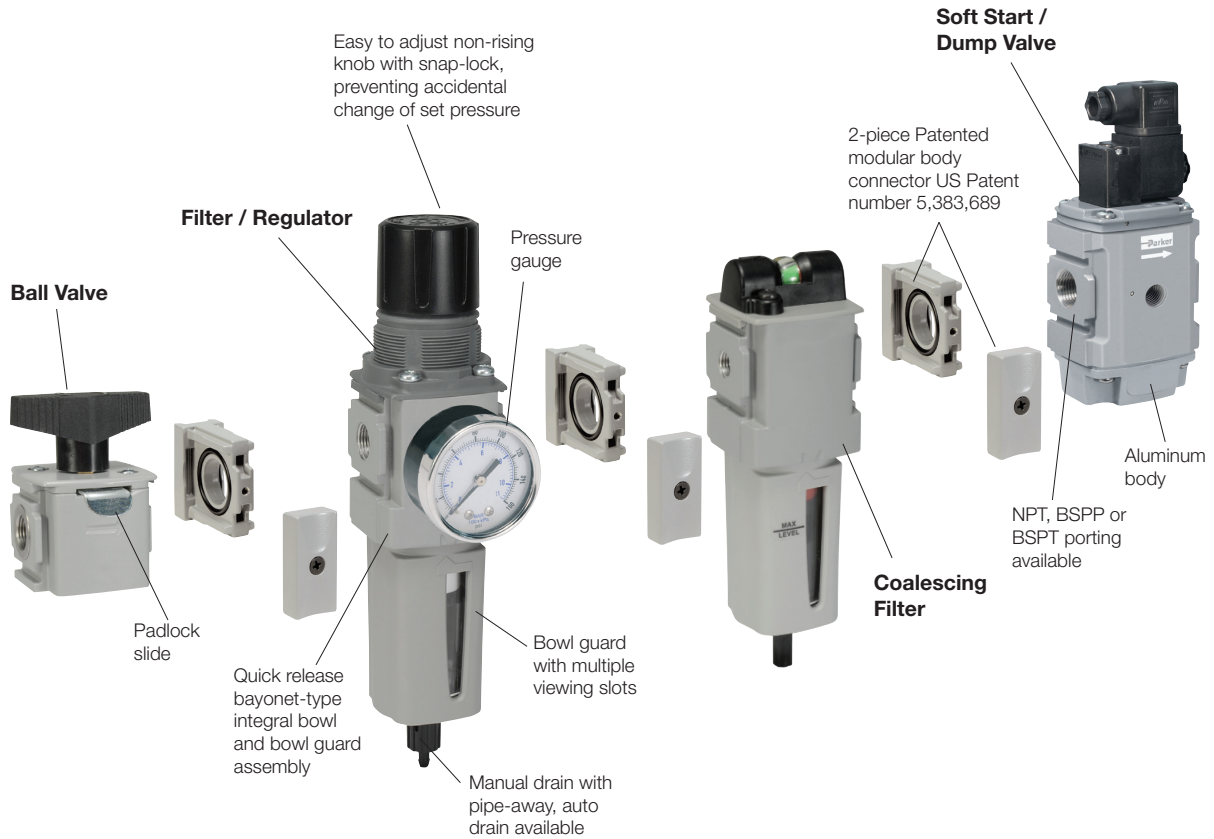

- Mixity between sizes P32 and P33 by using same mountings.
- Extended air ports sizes by adding end port blocks or for converting from BSPP body threaded to NPT.

	P31	P32	P33	BSPP	NPT	BSPT
1/8"	■			■	■	■
1/4"	□	□	■	■	■	■
3/8"		□	■	■	■	■
1/2"		□	□	■	■	■
3/4"		■	□	■	■	■

■ With end blocks
 □ Body threaded



Global Comprehensive Offering



P31 Mini Series
1/4" ports
40mm body width



P32 Compact Series
1/4", 3/8" and 1/2"
60mm body width



P33 Standard Series
1/2" and 3/4"
73mm body width



Filters

- 5 μ particulate, 1.0 μ and 0.01 μ coalescing, and adsorber available as standard
- Transparent or metal bowl with manual or auto float drains standard



Regulators

- Available as stand alone, common port and electronic proportional
- Both relieving and non-relieving versions available



Filter / Regulators

- Compact design for space savings
- Available with all the same standard options as the filters and regulators



Lubricators

- Proportional oil delivery over a wide range of air flows
- Fill under pressure



Combinations

- Compact design for space savings
- Easily assembled
- Many configurations available



Accessories

- Solenoid operated soft start, quick dump, and soft start/quick dump valves
- Manifold blocks
- Ball style lockout / shutoff valve
- Repair kits, gauges, etc.

P3Y Comprehensive Offering



P3Y Series
3/4" and 1"
90mm body width



Filters

- 5 μ particulate, 1.0 μ and 0.01 μ coalescing, and adsorber available as standard
- Polypropylene bowl with metal screw in bowl guard



Regulators

- Available as a stand alone high flow unit with a rolling diaphragm to extend life
- Optional key lock



Filter / Regulators

- Compact design for space savings
- Available with all the same standard options as the filters and regulators



Lubricators

- Proportional oil delivery over a wide range of air flows
- Fill under pressure



Combinations

- Compact design for space savings
- Easily assembled



Accessories

- Solenoid operated soft start, quick dump, and soft start/quick dump valves
- Manifold blocks
- Ball style lockout / shutoff valve
- Repair kits, gauges, etc.

PDE2676TCUK

Global FRL and P3Y Series

Air Preparation

Complete Air Preparation

P31 Mini Series



40mm body width

1/4" Ported

Flows up to:	scfm	(dm ³ /s, ANR)
Filter	25	(12)
Coalescer	7.5	(3.6)
Regulator	68	(32)
Filter/Regulator	74	(35)
Lubricator	52	(25)

Features:

- Space saving integral gauge
- Manifold style regulators available
- OSHA compliant shut-off valves
- Soft-Start & Quick Dump valves
- Electronic Proportional Regulator

P32 Compact Series

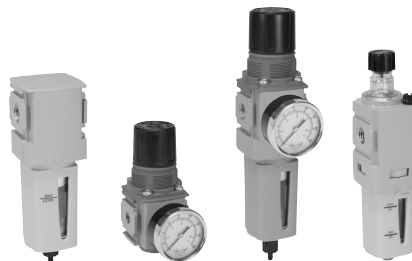

60mm body width

1/4", 3/8", & 1/2" Ported

Flows up to:	scfm	(dm ³ /s, ANR)
Filter	82	(39)
Coalescer	36	(17)
Regulator	165	(78)
Filter/Regulator	164	(77)
Lubricator	90	(42)

Features:

- Manifold style regulators available
- OSHA Compliant shut-off valves
- Soft-Start & Quick Dump valves
- Electronic Proportional Regulator

P33 Standard Series



73mm body width

1/2" & 3/4" Ported

Flows up to:	scfm	(dm ³ /s, ANR)
Filter	102	(48)
Coalescer	42	(20)
Regulator	233	(110)
Filter/Regulator	235	(109)
Lubricator	150	(71)

Features:

- OSHA Compliant shut-off valves
- Soft-Start & Quick Dump valves (Utilizes P32 size only)
- Electronic proportional regulator (Utilizes P32 size only)

P3Y Large Series



90mm body width

3/4" and 1" Ported

Flows up to:	scfm	(dm ³ /s, ANR)
Filter	170	(80)
Coalescer	307	(150)
Regulator	550	(260)
Filter/Regulator	465	(220)
Lubricator	390	(184)

Features:

- OSHA Compliant shut-off valves
- Soft-Start & Quick Dump valves
- Electronic Proportional Regulator



Complete FRL System

Safety Exhaust Valves

- External monitoring provides a cost and space saving advantage
- Solid state pressure sensors provide accurate, fast fault detection
- Quick visual LED indicators on the front of the valve
- Safety exhaust outlet is no-maintenance and non-clog by design
- Suitable for stand alone use or modular mounting to P32 or P33 FRL assembly



(optional soft start)

Semi Precision Regulators and Filter / Regulators

- Available in P32 compact series
- Fine adjustment sensitivity
- Good repeatability and minimal pressure drop
- Good flow capacity
- Light gray knob for easy identification



Common Port Manifold Regulators

- Multiple output pressures (P2, P3, P4, etc.) with common inlet (P1)
- Available in two sizes P31 and P32
- Balanced valve design for accurate pressure regulation
- Outlet pressure ports in front and rear of unit
- Multiple spring ranges available

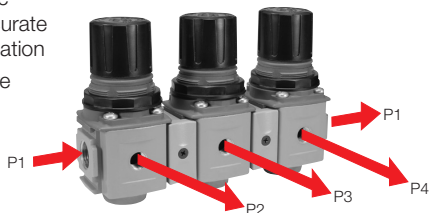

Optional Tamperproof Kits

- One facilitates the permanent tamperproofing of the Regulator and Filter/Regulator units
- Hinged black part clamps over control knob and is locked in place after sliding yellow cover over it
- Other allows for removable lockout/tagout tamperproofing
 - Four pad lock location holes tagout
 - Hinged locking clamp secures over existing knob via yellow cover which is slid over into place



Electronic Proportional Regulators

- Electro-Pneumatic regulator
- Integrated systems control
- Accurate output pressure
- Micro parameter settings
- Selectable I/O parameters
- Quick, full flow exhaust
- LED display indicates output pressure
- No air consumption in steady state
- Multiple mounting options
- Protection to IP65



P31P Mini Series



P32P Compact Series

Additional Options P32 Only

(Consult factory for availability)

- T-Handle
- Preset and Tamperproof
- Preset
- Pressure Limiter



Together we can power your application with clean, dry air

Fast cycle times, high product quality, and low downtime all require a clean, dry pneumatic system to function properly. Parker has what it takes to make sure pneumatic systems perform at their best.

Clean, dry pneumatic systems with Parker Global Air Preparation

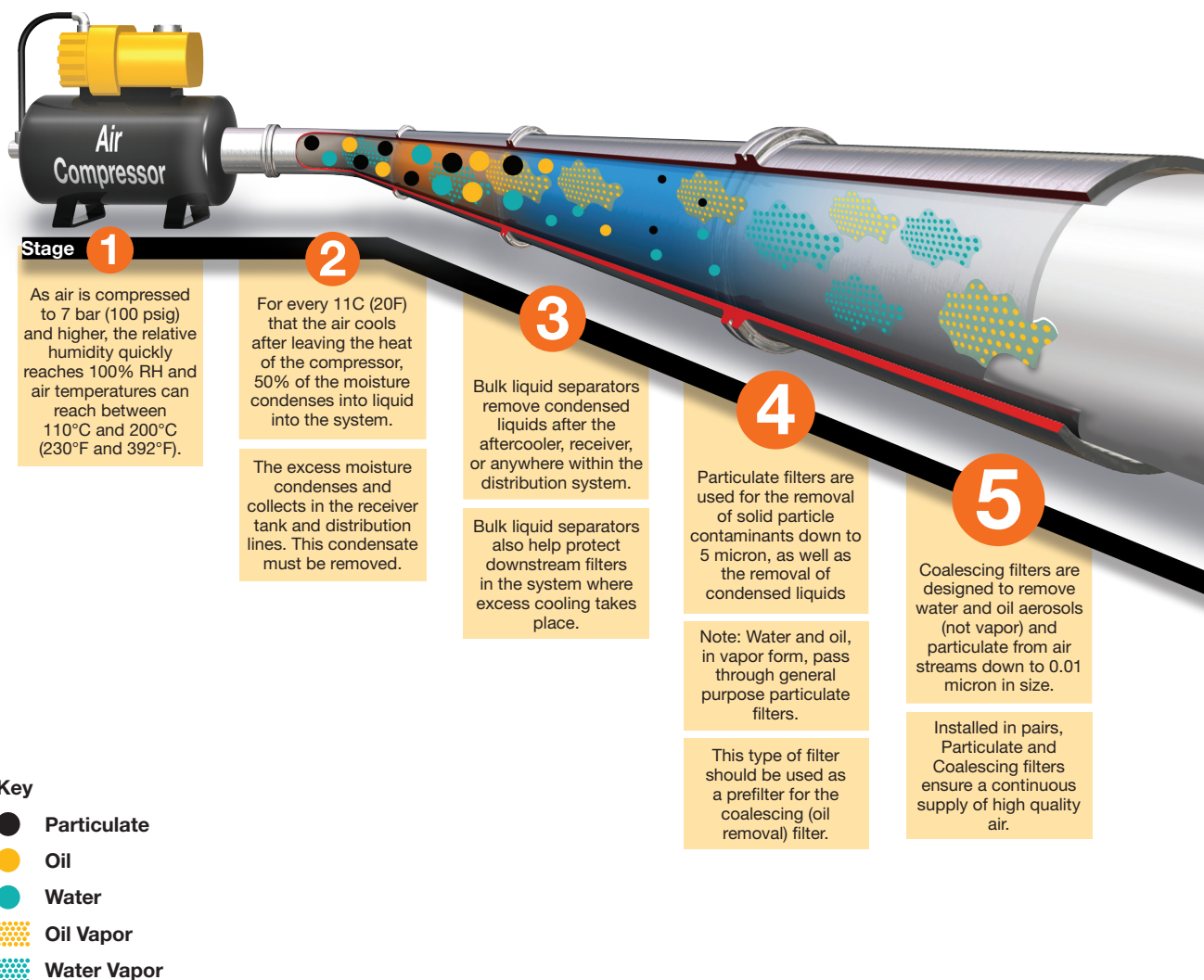

Stages	1 2	3	4	5	6	7
Function	Air Compressor	Bulk Liquid Removal	Particulate Filtration	Coalescing Filtration	Air Dryers	Hydrocarbon Removal
Application	All pneumatic systems	Basic pneumatic systems	Basic pneumatic systems	Systems requiring highest quality air.	Systems requiring air with reduced moisture content	Systems requiring highest quality air for critical applications
Description	Air leaving the compressor room at 93°C (200°F) releases 95% of its moisture into the piping system when it cools to 38°C (100°F)	Removes bulk liquid contamination and protects filters where excess cooling takes place in the distribution piping	Removes solid particulates down to 5 micron, and the separation of bulk contaminants.	Removes liquid aerosols and submicron particulates (not vapor) down to 0.01 micron.	Removes water vapor from air stream. Dew point reduced down to 4°C (40°F) (refrigeration) or -40°C (-40°F) (desiccant).	Removal of odors and trace vapors for critical applications.
Parker Global Air Preparation Solution	Customer supplied	P3TF Bulk Liquid Separator	P31, P32, P33 Particulate Filter	P31, P32, P33 Coalescing Filter	Refrigeration Dryer, TW Regenerative Desiccant Dryer	P31, P32, P33 Activated Carbon (Adsorber) Filter



Specifying air quality (purity) in accordance with ISO8573-1:2010, the international standard for compressed air quality

ISO8573-1 is the primary document used from the ISO8573 series as it is this document which specifies the amount of contamination allowed in each cubic metre of compressed air.

ISO8573-1 lists the main contaminants as Solid Particulate, Water and Oil. The purity levels for each contaminant are shown separately in tabular form, however for ease of use, this document combines all three contaminants into one easy to use table.

ISO8573-1:2010 CLASS	Solid Particulate			Mass Concentration mg/m ³	Water		Oil Total Oil (aerosol liquid and vapour) mg/m ³
	Maximum number of particles per m ³				Vapour Pressure Dewpoint	Liquid g/m ³	
	0,1 - 0,5 micron	0,5 - 1 micron	1 - 5 micron				
0	As specified by the equipment user or supplier and more stringent than Class 1						
1	≤ 20 000	≤ 400	≤ 10	-	≤ -70 °C	-	0,01
2	≤ 400 000	≤ 6 000	≤ 100	-	≤ -40 °C	-	0,1
3	-	≤ 90 000	≤ 1 000	-	≤ -20 °C	-	1
4	-	-	≤ 10 000	-	≤ +3 °C	-	5
5	-	-	≤ 100 000	-	≤ +7 °C	-	-
6	-	-	-	≤ 5	≤ +10 °C	-	-
7	-	-	-	5 - 10	-	≤ 0,5	-
8	-	-	-	-	-	0,5 - 5	-
9	-	-	-	-	-	5 - 10	-
X	-	-	-	> 10	-	> 10	> 10

Specifying air purity in accordance with ISO8573-1:2010

When specifying the purity of air required, the standard must always be referenced, followed by the purity class selected for each contaminant (a different purity class can be selected for each contamination if required).

An example of how to write an air quality specification is shown below:

ISO 8573-1:2010 Class 1.2.1

ISO 8573-1:2010 refers to the standard document and its revision, the three digits refer to the purity classifications selected for solid particulate, water and total oil. Selecting an air purity class of 1.2.1 would specify the following air quality when operating at the standard's reference conditions:

Class 1 - Particulate

In each cubic metre of compressed air, the particulate count should not exceed 20,000 particles in the 0.1 - 0.5 micron size range, 400 particles in the 0.5 - 1 micron size range and 10 particles in the 1 - 5 micron size range.

Class 2 - Water

A pressure dewpoint (PDP) of -40°C or better is required and no liquid water is allowed.

Class 1 - Oil

In each cubic metre of compressed air, not more than 0.01mg of oil is allowed. This is a total level for liquid oil, oil aerosol and oil vapour.

ISO8573-1:2010 Class zero

- **Class 0 does not mean zero contamination.**
- **Class 0 requires the user and the equipment manufacturer to agree contamination levels as part of a written specification.**
- **The agreed contamination levels for a Class 0 specification should be within the measurement capabilities of the test equipment and test methods shown in ISO8573 Pt 2 to Pt 9.**
- **The agreed Class 0 specification must be written on all documentation to be in accordance with the standard.**
- **Stating Class 0 without the agreed specification is meaningless and not in accordance with the standard.**
- **A number of compressor manufacturers claim that the delivered air from their oil-free compressors is in compliance with Class 0.**
- **If the compressor was tested in clean room conditions, the contamination detected at the outlet will be minimal. Should the same compressor now be installed in typical urban environment, the level of contamination will be dependent upon what is drawn into the compressor intake, rendering the Class 0 claim invalid.**
- **A compressor delivering air to Class 0 will still require purification equipment in both the compressor room and at the point of use for the Class 0 purity to be maintained at the application.**
- **Air for critical applications such as breathing, medical, food, etc typically only requires air quality to Class 2.2.1 or Class 2.1.1.**
- **Purification of air to meet a Class 0 specification is only cost effective if carried out at the point of use.**

Application Guide

FRL to Valve: The chart below contains recommendations for the correct selection of Global Air Preparation units to suit the number and size of valves in a typical application.

	P31 Mini Series				P32 Compact Series						P33 Standard Series					
	Number of valves that would actuate at once															
	1	2	3	4	5	6	7	8	9	10	11	12	13	14	15	16
Moduflex 1	Shaded	Shaded	Shaded	Shaded	Shaded	White	White	White	White	White	White	White	White	White	White	White
Isys Micro	Shaded	Shaded	Shaded	Shaded	White	White	White	White	White	White	White	White	White	White	White	White
HB / Viking Xtreme	Shaded	Shaded	Shaded	White	White	White	White	White	White	White	White	White	White	White	White	White
Moduflex 2	Shaded	Shaded	White	White	White	White	White	White	White	White	White	White	White	White	White	White
HA / Global ISO	Shaded	White	White	White	White	White	White	White	White	White	White	White	White	White	White	White
See Large P3Y Series																

Actuator to FRL: The chart below contains recommendations for the correct selection of Global Air Preparation units suitable for each cylinder size. If you have a tube length over 2 m, choose one tube size larger than the chart. The table is based on a Maximum cylinder speed of 0.5m/s

Cyl Ø mm Cyl Ø inches		Cylinder bore size														
		5 (5/16)	10 (7/16)	16 (9/16)	20 (3/4)	25 (1)	28 (1-1/8)	32 (1-1/4)	40 (1-1/2)	45 (1-3/4)	50 (2)	63 (2-1/2)	75 (3)	80 (3-1/4)	100 (4)	
Tube Ø mm Tube Ø inches		Tube diameter external														
		4 (5/32)	4 (5/32)	4 (5/32)	6 (1/4)	6 (1/4)	6 (1/4)	6 (1/4)	8 (5/16)	8 (5/16)	8 (5/16)	10 (3/8)	10 (3/8)	12 (1/2)	12 (1/2)	
Number of cylinders actuating at once	1	Shaded	Shaded	Shaded	Shaded	Shaded	Shaded	Shaded	Shaded	Shaded	Shaded	Shaded	Shaded	Shaded	White	White
	2	Shaded	Shaded	Shaded	Shaded	Shaded	Shaded	Shaded	Shaded	Shaded	Shaded	Shaded	Shaded	Shaded	White	White
	3	Shaded	Shaded	Shaded	Shaded	Shaded	Shaded	Shaded	Shaded	Shaded	Shaded	Shaded	Shaded	Shaded	White	White
	4	Shaded	Shaded	Shaded	Shaded	Shaded	Shaded	Shaded	Shaded	Shaded	Shaded	Shaded	Shaded	Shaded	White	White
	5	Shaded	Shaded	Shaded	Shaded	Shaded	Shaded	Shaded	Shaded	Shaded	Shaded	Shaded	Shaded	Shaded	White	White
	6	Shaded	Shaded	Shaded	Shaded	Shaded	Shaded	Shaded	Shaded	Shaded	Shaded	Shaded	Shaded	Shaded	White	White
	7	Shaded	Shaded	Shaded	Shaded	Shaded	Shaded	Shaded	Shaded	Shaded	Shaded	Shaded	Shaded	Shaded	White	White
	8	Shaded	Shaded	Shaded	Shaded	Shaded	Shaded	Shaded	Shaded	Shaded	Shaded	Shaded	Shaded	Shaded	White	White
	9	Shaded	Shaded	Shaded	Shaded	Shaded	Shaded	Shaded	Shaded	Shaded	Shaded	Shaded	Shaded	Shaded	White	White
	10	Shaded	Shaded	Shaded	Shaded	Shaded	Shaded	Shaded	Shaded	Shaded	Shaded	Shaded	Shaded	Shaded	White	White
		P31 Mini Series				P32 Compact Series				P33 Standard Series				Large P3Y Series		

Note: Data listed above is simply a guideline for a typical application only. Proper sizing and correct flow requirements must be taken into account.

P31 Particulate Filter – Mini

- Integral 1/4" ports (NPT, BSPP & BSPT)
- High efficiency 5 micron element as standard
- Excellent water removal efficiency
- Robust but lightweight aluminum construction
- One hand operation for easy element cartridge removal
- Positive bayonet latch to ensure correct & safe fitting

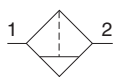

Manual drain

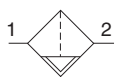

Pulse drain

Port Size	Description †	Part Number
1/4"	Poly Bowl, Manual Drain	P31FB12EGMN
1/4"	Poly Bowl, Pulse Drain	P31FB12EGBN
1/4"	Metal Bowl, Manual Drain	P31FB12EMMN
1/4"	Metal Bowl, Pulse Drain	P31FB12EMBN

† For polycarbonate bowl, see caution in Engineering Section A.

Operating Information

Supply pressure (max):	
Plastic bowl	150 psig (10 bar)
Metal bowl	250 psig (17 bar)
Operating temperature:	
Plastic bowl	14°F to 125°F (-10°C to 52°C)
Metal bowl	14°F to 150°F (-10°C to 65.5°C)
Standard filtration:	5 micron
Flow capacity*:	25 scfm (12 dm ³ /s, ANR)
Useful retention†:	0.4 US oz. (12 cm ³)
Weight:	0.24 lb (0.11 kg)

* Inlet pressure 91.3 psig (6.3 bar). Pressure drop 4.9 psig (0.34 bar).
† Useful retention refers to volume below the quiet zone baffle.

Air quality:
Within ISO 8573-1: 2010 Class 6 (Particulates)

Ordering Information:

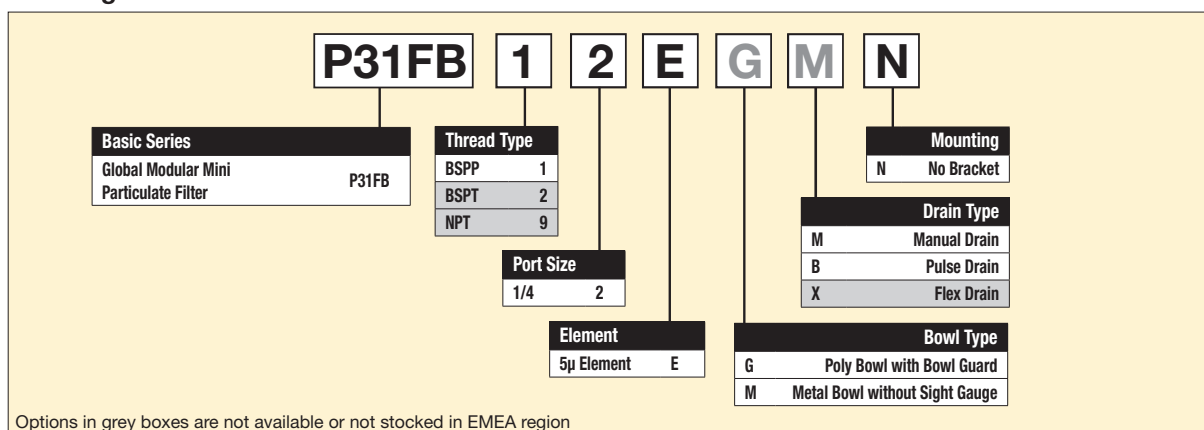

PDE2676TCUK

Global FRL and P3Y Series

P31, P32, P33 Series Mini Particulate Filters

Material Specifications

Body	Aluminum
Body cap	ABS
Plastic bowl	Polycarbonate
Metal bowl	Aluminum
Bowl guard	Nylon
Element retainer	Acetal
Baffle	Acetal
Filter element	Sintered polyethylene
Seals	Nitrile

Repair and Service Kits

Plastic bowl / bowl guard, manual drain	P31KB00BGM
Metal bowl / w/o sight gauge, manual drain	P31KB00BMM
Plastic bowl / bowl guard, pulse drain	P31KB00BGB
Metal bowl / w/o sight gauge, pulse drain	P31KB00BMB
5µ particle filter element	P31KA00ESE
C-bracket (fits to body)	P31KA00MW
T-bracket with body connector	P31KA00MT
Body connector	P31KA00CB

Flow Charts

P31FB 1/4" Filter

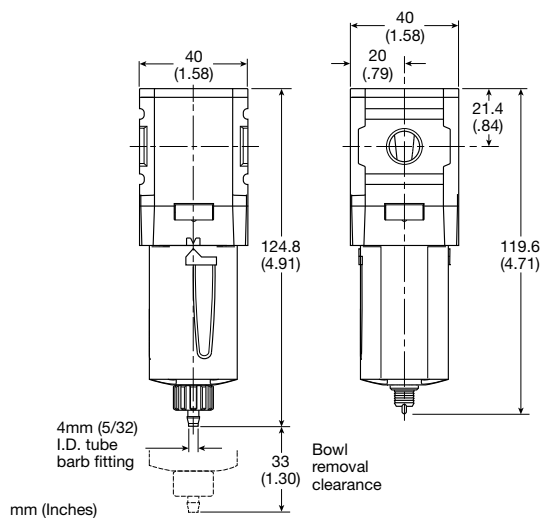
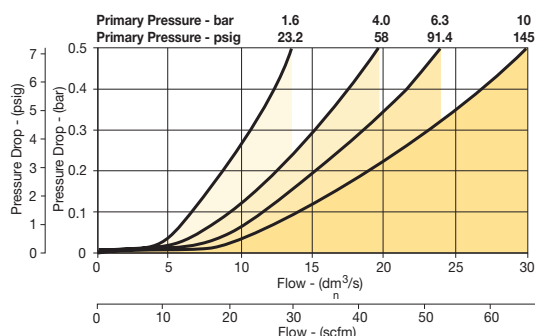

Manual Drain

Pulse Drain



P32 Particulate Filter – Compact

- Integral 1/4", 3/8" or 1/2" ports (NPT, BSPP & BSPT)
- High efficiency 5 micron element as standard
- Excellent water removal efficiency
- Robust but lightweight aluminum construction
- Positive bayonet latch to ensure correct & safe fitting

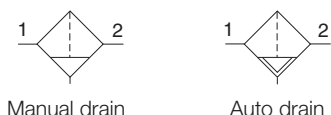

Port Size	Description †	Part Number
1/4"	Poly Bowl, Manual Drain	P32FB12EGMN
1/4"	Poly Bowl, Auto Drain	P32FB12EGAN
1/4"	Metal Bowl, Manual Drain	P32FB12ESMN
1/4"	Metal Bowl, Auto Drain	P32FB12ESAN
3/8"	Poly Bowl, Manual Drain	P32FB13EGMN
3/8"	Poly Bowl, Auto Drain	P32FB13EGAN
3/8"	Metal Bowl, Manual Drain	P32FB13ESMN
3/8"	Metal Bowl, Auto Drain	P32FB13ESAN
1/2"	Poly Bowl, Manual Drain	P32FB14EGMN
1/2"	Poly Bowl, Auto Drain	P32FB14EGAN
1/2"	Metal Bowl, Manual Drain	P32FB14ESMN
1/2"	Metal Bowl, Auto Drain	P32FB14ESAN

† For polycarbonate bowl, see caution in Engineering Section A.

Operating Information

Supply pressure (max):	
Plastic bowl	150 psig (10 bar)
Metal bowl	250 psig (17 bar)
Operating temperature:	
Plastic bowl	-13°F to 125°F (-25°C to 52°C)
Metal bowl	-13°F to 150°F (-25°C to 65.5°C)
Standard filtration:	5 micron
Flow capacity*:	1/4 50 scfm (24 dm ³ /s, ANR)
	3/8 78 scfm (37 dm ³ /s, ANR)
	1/2 82 scfm (39 dm ³ /s, ANR)
Useful retention†:	1.7 US oz. (51 cm ³)
Weight:	0.62 lb (0.28 kg)

* Inlet pressure 91.3 psig (6.3 bar). Pressure drop 4.9 psig (0.34 bar).

† Useful retention refers to volume below the quiet zone baffle.

Air quality: Within ISO 8573-1: 2010 Class 6 (Particulates)

Ordering Information:

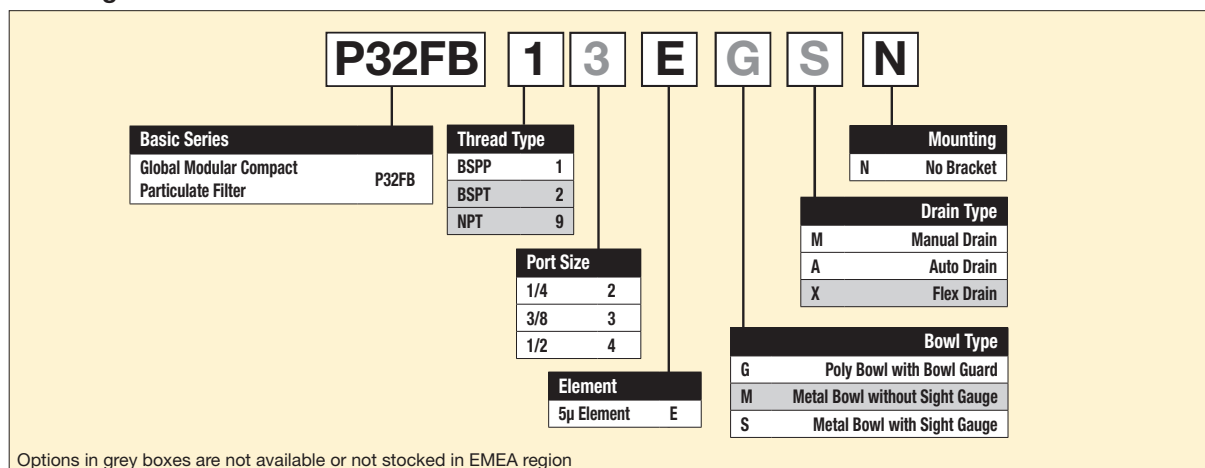

PDE2676TCUK
Global FRL and P3Y Series

P31, P32, P33 Series
Compact Particulate Filters

Material Specifications

Body	Aluminum
Body cap	ABS
Plastic bowl	Polycarbonate
Metal bowl	Aluminum
Bowl guard	Nylon
Deflector	Polypropylene
Element retainer / Baffle	Acetal
Filter element	Sintered polyethylene
Seals	Nitrile
Sight gauge	Nylon

Repair and Service Kits

Plastic bowl / bowl guard, manual drain	P32KB00BGM
Metal bowl / sight gauge, manual drain	P32KB00BSM
Auto drain	P32KA00DA
5µ particle filter element	P32KA00ESE
L-bracket (fits to body)	P32KA00ML
T-bracket (fits to body connector)	P32KA00MB
T-bracket with body connector	P32KA00MT
Body connector	P32KA00CB

Flow Charts

P32FB 1/4" Filter

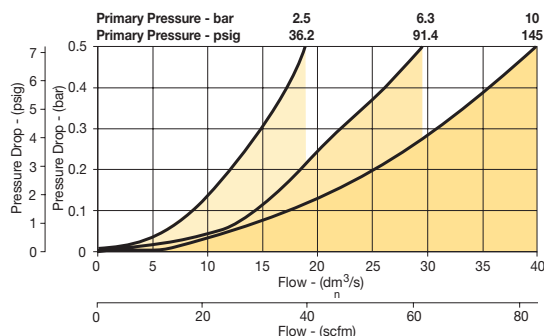

P32FB 3/8" Filter

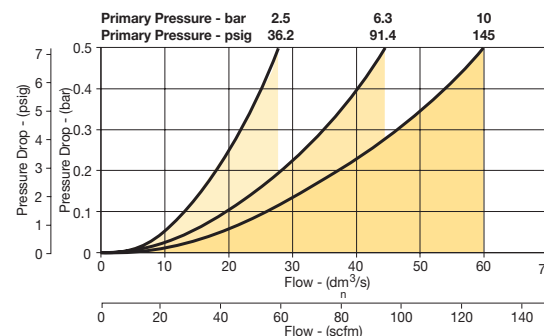

P32FB 1/2" Filter

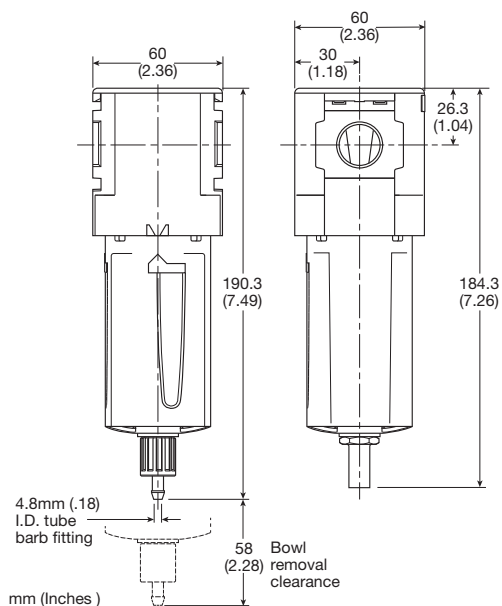
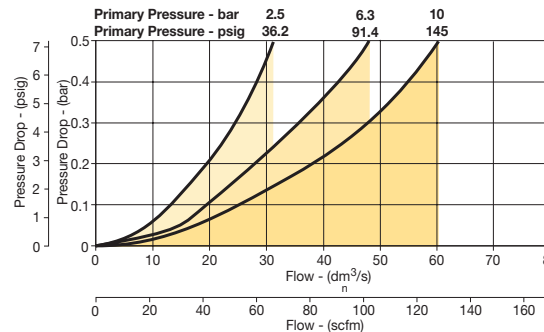

Manual Drain

Automatic Drain



P33 Particulate Filter – Standard

- Integral 1/2" or 3/4" ports (NPT, BSPP & BSPT)
- High efficiency 5 micron element as standard
- Excellent water removal efficiency
- Robust but lightweight aluminum construction
- Positive bayonet latch to ensure correct & safe fitting

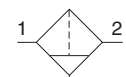

Manual drain

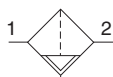

Auto drain



Port Size	Description †	Part Number
1/2"	Poly Bowl, Manual Drain	P33FA14EGMN
1/2"	Poly Bowl, Auto Drain	P33FA14EGAN
1/2"	Metal Bowl, Manual Drain	P33FA14ESMN
1/2"	Metal Bowl, Auto Drain	P33FA14ESAN
3/4"	Poly Bowl, Manual Drain	P33FA16EGMN
3/4"	Poly Bowl, Auto Drain	P33FA16EGAN
3/4"	Metal Bowl, Manual Drain	P33FA16ESMN
3/4"	Metal Bowl, Auto Drain	P33FA16ESAN

† For polycarbonate bowl, see caution in Engineering Section A.

Operating Information

Supply pressure (max):	
Plastic bowl	150 psig (10 bar)
Metal bowl	250 psig (17 bar)
Operating temperature:	
Plastic bowl	-13°F to 125°F (-25°C to 52°C)
Metal bowl	-13°F to 150°F (-25°C to 65.5°C)
Standard filtration:	5 micron
Flow capacity*:	1/2 85 scfm (40 dm ³ /s, ANR)
	3/4 102 scfm (48 dm ³ /s, ANR)
Useful retention†:	2.8 US oz. (85 cm ³)
Weight:	1.01 lb (0.46 kg)

* Inlet pressure 91.3 psig (6.3 bar). Pressure drop 4.9 psig (0.34 bar).

† Useful retention refers to volume below the quiet zone baffle.

Air quality: Within ISO 8573-1: 2010 Class 6 (Particulates)

Ordering Information:

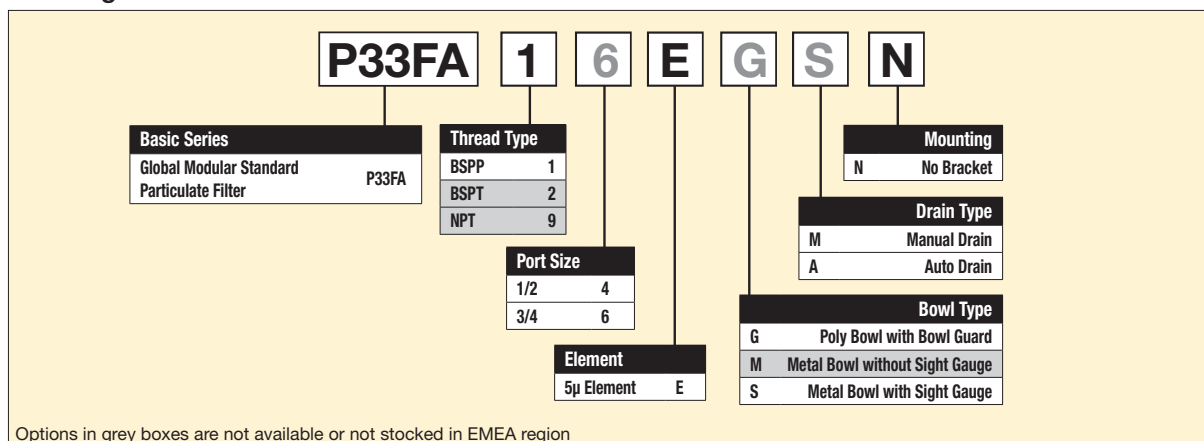

PDE2676TCUK
Global FRL and P3Y Series

P31, P32, P33 Series
Standard Particulate Filters

Material Specifications

Body	Aluminum
Body cap	ABS
Plastic bowl	Polycarbonate
Metal bowl	Aluminum
Bowl guard	Nylon
Deflector	Polypropylene
Element retainer / Baffle	Acetal
Filter element	Sintered polyethylene
Seals	Nitrile
Sight gauge	Nylon

Flow Charts

P33FA 1/2" Filter

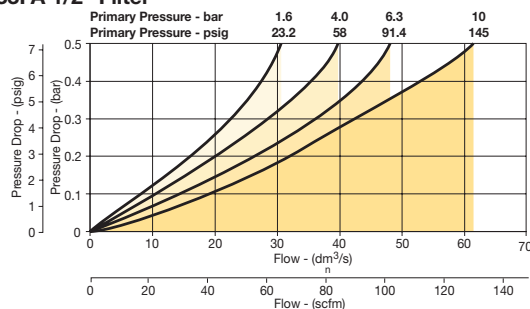

P33FA 3/4" Filter

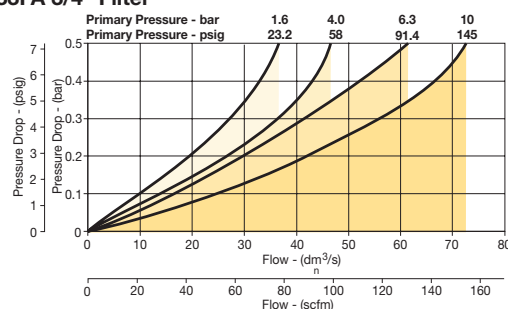

Repair and Service Kits

Plastic bowl / bowl guard, manual drain	P33KA00BGM
Metal bowl / sight gauge, manual drain	P33KA00BSM
Auto drain	P32KA00DA
5µ particle filter element	P33KA00ESE
L-bracket (fits to body)	P33KA00ML
T-bracket (fits to body connector)	P32KA00MB
T-bracket with body connector	P33KA00MT
Body connector	P32KA00CB

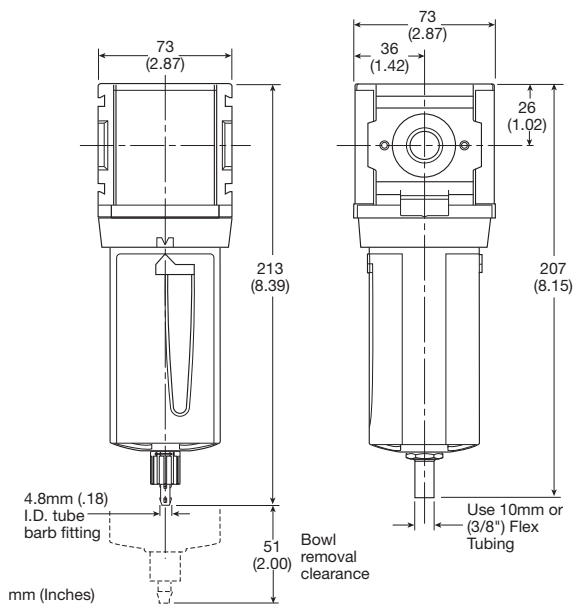

Manual Drain

Automatic Drain



P31 Coalescing and Adsorber Filters – Mini

- Integral 1/4" ports (NPT, BSPP & BSPT)
- Removes liquid aerosols and sub micron particles
- Oil free air for critical applications, such as air gauging, pneumatic instrumentation and control
- Differential Pressure Indicator (DPI) standard on coalescing filters
- Positive bayonet latch to ensure correct and safe fitting
- Adsorbing activated carbon element removes oil vapors and most hydrocarbons



Note: To optimize the life of coalescing element, it is advisable to install a P31F pre-filter with a 5 micron element upstream of the coalescing filter.

To optimize the life of an Adsorber it is advisable to install a P31 Coalescing Filter upstream of the Adsorber. Adsorber element should be replaced approximately every 1000 hours of service.

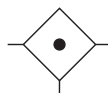

Port Size	Description †	Element	Part Number
1/4"	Poly Bowl, Manual Drain	0.01 micron	P31FB12DGMN
1/4"	Poly Bowl, Pulse Drain	0.01 micron	P31FB12DGBN
1/4"	Metal Bowl, Manual Drain	0.01 micron	P31FB12DMMN
1/4"	Metal Bowl, Pulse Drain	0.01 micron	P31FB12DMBN

† For polycarbonate bowl, see caution in Engineering Section A.

Operating Information

Supply pressure (max):	
Poly bowl	150 psig (10 bar)
Metal bowl w/ DPI	150 psig (10 bar)
Metal bowl w/o DPI	250 psig (17 bar)
Operating temperature:	
Plastic bowl	14°F to 125°F (-10°C to 52°C)
Metal bowl	14°F to 150°F (-10°C to 65.5°C)
Standard filtration:	1.0 and 0.01 micron
Adsorber	Max. oil carryover (ppm w/w) 0.003 @ 70°F (21°C)
Flow capacity*:	
1.0 micron coalescing	12 scfm (5.5 dm ³ /s, ANR)
0.01 micron coalescing	7.5 scfm (3.6 dm ³ /s, ANR)
Activated carbon adsorber	12.7 scfm (6 dm ³ /s, ANR)
Useful retention†:	0.4 US oz. (12 cm ³)
Weight:	0.24 lb (0.11 kg)

* Inlet pressure 91.3 psig (6.3 bar). Pressure drop 3 psig (0.2 bar), saturated element.

† Useful retention refers to volume below the quiet zone baffle.

Air quality:ISO 8573-1:2010: 0.01µm closes to Class 1 for maximum particle size and concentration of solid contaminants, and closes to Class 1 on maximum oil content (ppm/wt).
Within ISO 8573-1:2010: Adsorber closes to Class 1 on maximum oil content (ppm/wt).

Ordering Information:

Basic Series		Thread Type		Port Size		Element		Mounting		Drain Type		Bowl Type	
Global Modular Mini Coalescing Filter	P31FB	BSPP	1	1/4	2	0.01µ Element	C	N	No Bracket	B	Pulse Drain	G	Poly Bowl with Bowl Guard
		BSPT	2			0.01µ Element with DPI	D			M	Manual Drain	M	Metal Bowl without Sight Gauge
		NPT	9			1µ Element	9			X	Flex Drain		
						1µ Element with DPI	Q						
						Adsorber	A						

Options in grey boxes are not available or not stocked in EMEA region

PDE2676TCUK

Global FRL and P3Y Series

P31, P32, P33 Series

Mini Coalescing and Adsorber Filters

Material Specifications

Body	Aluminum
Body cap	ABS
Plastic bowl	Polycarbonate
Metal bowl	Aluminum
Filter element	Borosilicate cloth
Adsorber element	Activated carbon
Seals	Nitrile

Flow Charts

P31FB - 1.0 micron flow

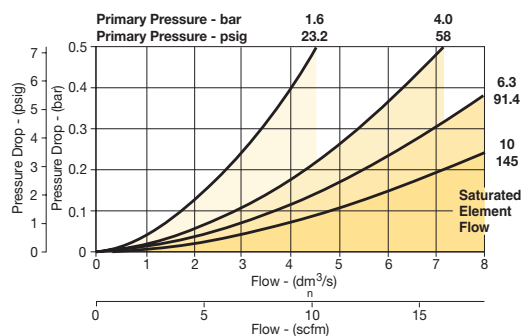

Repair and Service Kits

Plastic bowl / bowl guard, manual drain	P31KB00BGM
Metal bowl / w/o sight gauge, manual drain	P31KB00BMM
Plastic bowl / bowl guard, pulse drain	P31KB00BGB
Metal bowl / w/o sight gauge, pulse drain	P31KB00BMB
1μ coalescing filter element	P31KA00ES9
0.01μ coalescing filter element	P31KA00ESC
Activated carbon adsorber filter element	P31KA00ESA
C-bracket (fits to body)	P31KA00MW
T-bracket with body connector	P31KA00MT
Body connector	P31KA00CB
Differential pressure indicator (replacement)	P31KB00RQ

P31FB - 0.01 micron flow

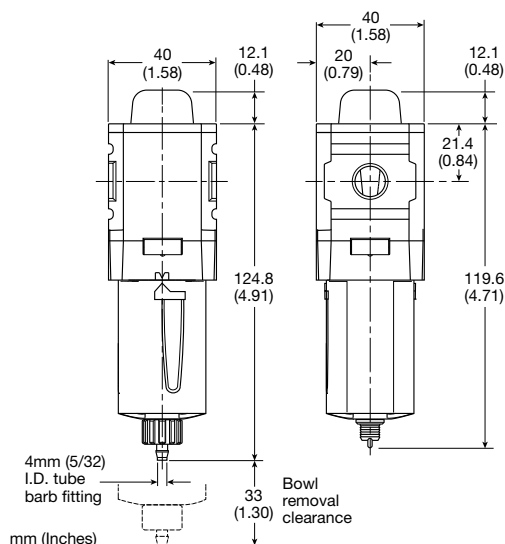
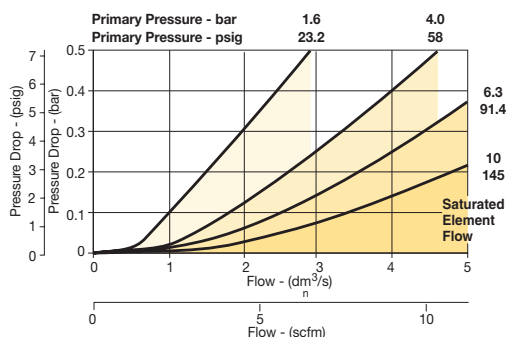

Manual Drain

Pulse Drain



P32 Coalescing and Adsorber Filters – Compact

- Integral 1/4", 3/8" or 1/2" ports (NPT, BSPP & BSPT)
- Removes liquid aerosols and sub micron particles
- Oil free air for critical applications, such as air gauging, pneumatic instrumentation and control
- Differential Pressure Indicator (DPI) standard on Coalescing Filters
- Positive bayonet latch to ensure correct & safe fitting
- Adsorbing activated carbon element removes oil vapors and most hydrocarbons

Note: To optimize the life of coalescing element, it is advisable to install a P32F pre-filter with a 5 micron element upstream of the coalescing filter. To optimize the life of an Adsorber it is advisable to install a P32 Coalescing Filter upstream of the Adsorber. Adsorber element should be replaced approximately every 1000 hours of service.



Port Size	Description †	Element	Part Number
1/4"	Poly Bowl, Manual Drain	0.01 micron	P32FB12DGMN
1/4"	Poly Bowl, Auto Drain	0.01 micron	P32FB12DGAN
1/4"	Metal Bowl, Manual Drain	0.01 micron	P32FB12DSMN
1/4"	Metal Bowl, Auto Drain	0.01 micron	P32FB12DSAN
3/8"	Poly Bowl, Manual Drain	0.01 micron	P32FB13DGMN
3/8"	Poly Bowl, Auto Drain	0.01 micron	P32FB13DGAN
3/8"	Metal Bowl, Manual Drain	0.01 micron	P32FB13DSMN
3/8"	Metal Bowl, Auto Drain	0.01 micron	P32FB13DSAN
1/2"	Poly Bowl, Manual Drain	0.01 micron	P32FB14DGMN
1/2"	Poly Bowl, Auto Drain	0.01 micron	P32FB14DGAN
1/2"	Metal Bowl, Manual Drain	0.01 micron	P32FB14DSMN
1/2"	Metal Bowl, Auto Drain	0.01 micron	P32FB14DSAN

† For polycarbonate bowl, see caution in Engineering Section A.

Operating Information

Supply pressure (max):	
Poly bowl	150 psig (10 bar)
Metal bowl w/ DPI	150 psig (10 bar)
Metal bowl w/o DPI	250 psig (17 bar)
Operating temperature:	
Plastic bowl	-13°F to 125°F (-25°C to 52°C)
Metal bowl	-13°F to 150°F (-25°C to 65.5°C)
Standard filtration:	1.0 and 0.01 micron
Adsorber	Max. oil carryover (ppm w/w) 0.003 @ 70°F (21°C)
Flow capacity*:	
1.0 micron coalescing	53 scfm (25 dm³/s, ANR)
0.01 micron coalescing	36 scfm (17 dm³/s, ANR)
Activated carbon adsorber	85 scfm (40 dm³/s, ANR)
Useful retention†:	1.7 US oz. (51 cm³)
Weight:	0.71 lb (0.32 kg)

* Inlet pressure 91.3 psig (6.3 bar). Pressure drop 3 psig (0.2 bar), saturated element.

† Useful retention refers to volume below the quiet zone baffle.

Air quality:ISO 8573-1:2010: 0.01µm closes to Class 1 for maximum particle size and concentration of solid contaminants, and closes to Class 1 on maximum oil content (ppm/wt).
Within ISO 8573-1:2010: Adsorber closes to Class 1 on maximum oil content (ppm/wt).

Ordering Information:

P32FB		1	3	D	G	A	N
Basic Series	Global Modular Compact Coalescing Filter						
	P32FB						
Thread Type							
	BSPP	1					
	BSPT	2					
	NPT	9					
Port Size							
	1/4	2					
	3/8	3					
	1/2	4					
Element							
	0.01µ Element			C			
	0.01µ Element with DPI			D			
	1µ Element			9			
	1µ Element with DPI			Q			
	Adsorber			A			
Mounting							
	N					No Bracket	
Drain Type							
	M					Manual Drain	
	A					Auto Drain	
	X					Flex Drain	
Bowl Type							
	G					Poly Bowl with Bowl Guard	
	M					Metal Bowl without Sight Gauge	
	S					Metal Bowl with Sight Gauge	

Options in grey boxes are not available or not stocked in EMEA region

PDE2676TCUK
Global FRL and P3Y Series

P31, P32, P33 Series
Compact Coalescing and Adsorber Filters

Material Specifications

Body	Aluminum
Body cap	ABS
Plastic bowl	Polycarbonate
Metal bowl	Aluminum
Filter element	Borosilicate cloth
Adsorber	Activated carbon
Seals	Nitrile
Sight gauge	Nylon

Repair and Service Kits

Plastic bowl / bowl guard, manual drain	P32KB00BGM
Metal bowl / sight gauge, manual drain	P32KB00BSM
Auto drain	P32KA00DA
1 μ coalescing filter element	P32KA00ES9
0.01 μ coalescing filter element	P32KA00ESC
Activated carbon adsorber filter element	P32KA00ESA
L-bracket (fits to body)	P32KA00ML
T-bracket (fits to body connector)	P32KA00MB
T-bracket with body connector	P32KA00MT
Body connector	P32KA00CB
Differential pressure indicator (replacement)	P32KA00RQ

Flow Charts

P32FB - 1.0 micron flow

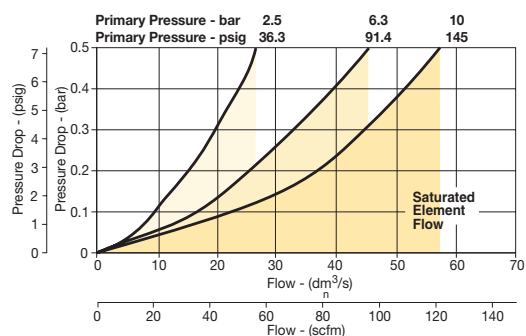

P32FB - 0.01 micron flow

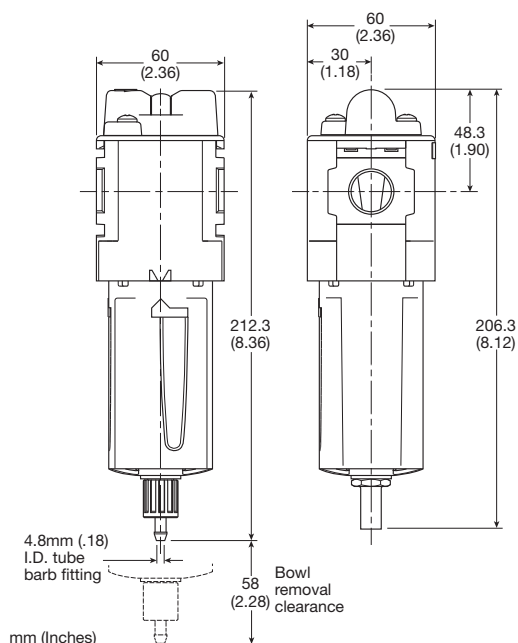
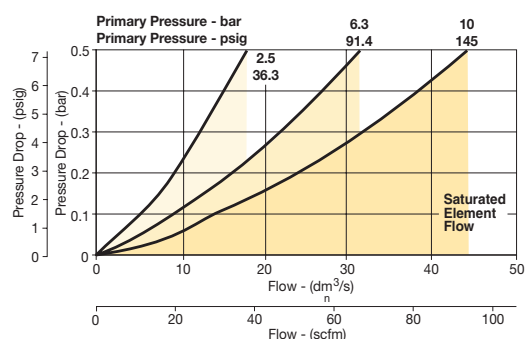

Manual Drain

Automatic Drain



P33 Coalescing and Adsorber Filters – Standard

- Integral 1/2" or 3/4" ports (NPT, BSPP & BSPT)
- Removes liquid aerosols and sub micron particles
- Oil free air for critical applications, such as air gauging, pneumatic instrumentation and control
- Differential Pressure Indicator (DPI) standard on Coalescing Filters
- Positive bayonet latch to ensure correct & safe fitting
- Adsorbing activated carbon element removes oil vapors and most hydrocarbons

Note: To optimize the life of coalescing element, it is advisable to install a P33F pre-filter with a 5 micron element upstream of the coalescing filter.

To optimize the life of an Adsorber it is advisable to install a P33 Coalescing Filter upstream of the Adsorber. Adsorber element should be replaced approximately every 1000 hours of service.

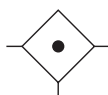

Port Size	Description †	Element	Part Number
1/2"	Poly Bowl, Manual Drain	0.01 micron	P33FA14DGMN
1/2"	Poly Bowl, Auto Drain	0.01 micron	P33FA14DGAN
1/2"	Metal Bowl, Manual Drain	0.01 micron	P33FA14DSMN
1/2"	Metal Bowl, Auto Drain	0.01 micron	P33FA14DSAN
3/4"	Poly Bowl, Manual Drain	0.01 micron	P33FA16DGMN
3/4"	Poly Bowl, Auto Drain	0.01 micron	P33FA16DGAN
3/4"	Metal Bowl, Manual Drain	0.01 micron	P33FA16DSMN
3/4"	Metal Bowl, Auto Drain	0.01 micron	P33FA16DSAN

† For polycarbonate bowl, see caution in Engineering Section A.

Operating Information

Supply pressure (max):	
Poly bowl	150 psig (10 bar)
Metal bowl w/ DPI	150 psig (10 bar)
Metal bowl w/o DPI	250 psig (17 bar)
Operating temperature:	
Plastic bowl	-13°F to 125°F (-25°C to 52°C)
Metal bowl	-13°F to 150°F (-25°C to 65.6°C)
Standard filtration:	1.0 and 0.01 micron
Adsorber	Max. oil carryover (ppm w/w) 0.003 @ 70°F (21°C)
Flow capacity*:	
1.0 micron coalescing	68 scfm (32 dm³/s, ANR)
0.01 micron coalescing	42 scfm (20 dm³/s, ANR)
Activated carbon adsorber	72 scfm (34 dm³/s, ANR)
Useful retention†:	2.8 US oz. (85 cm³)
Weight:	1.10 lb (0.50 kg)
* Inlet pressure 91.3 psig (6.3 bar). Pressure drop 3 psig (0.2 bar), saturated element.	
† Useful retention refers to volume below the quiet zone baffle.	

Air quality:ISO 8573-1:2010: 0.01µm closes to Class 1 for maximum particle size and concentration of solid contaminants, and closes to Class 1 on maximum oil content (ppm/wt).
 Within ISO 8573-1:2010: Adsorber closes to Class 1 on maximum oil content (ppm/wt).

Ordering Information:

P33FA		1	6	D	S	M	N
Basic Series	Global Modular Standard Coalescing Filter						
	P33FA						
Thread Type							
		BSPP 1					
		BSPT 2					
		NPT 9					
Port Size							
		1/2 4					
		3/4 6					
Element							
		0.01µ Element C					
		0.01µ Element with DPI D					
		1µ Element 9					
		1µ Element with DPI Q					
		Adsorber A					
Mounting							
							N No Bracket
Drain Type							
							M Manual Drain
							A Auto Drain
Bowl Type							
							G Poly Bowl with Bowl Guard
							M Metal Bowl without Sight Gauge
							S Metal Bowl with Sight Gauge

Options in grey boxes are not available or not stocked in EMEA region

PDE2676TCUK
Global FRL and P3Y Series

P31, P32, P33 Series
Standard Coalescing and Adsorber Filters

Material Specifications

Body	Aluminum
Body cap	ABS
Plastic bowl	Polycarbonate
Metal bowl	Aluminum
Filter element	Borosilicate cloth
Adsorber	Activated carbon
Seals	Nitrile
Sight gauge	Nylon

Repair and Service Kits

Plastic bowl / bowl guard, manual drain	P33KA00BGM
Metal bowl / sight gauge, manual drain	P33KA00BSM
Auto drain	P32KA00DA
1 μ coalescing filter element	P33KA00ES9
0.01 μ coalescing filter element	P33KA00ESC
Activated carbon adsorber filter element	P33KA00ESA
L-bracket (fits to body)	P33KA00ML
T-bracket (fits to body connector)	P32KA00MB
T-bracket with body connector	P32KA00MT
Body connector	P32KA00CB
Differential pressure indicator (replacement)	P32KA00RQ

Flow Charts

P33FA - 1.0 micron flow

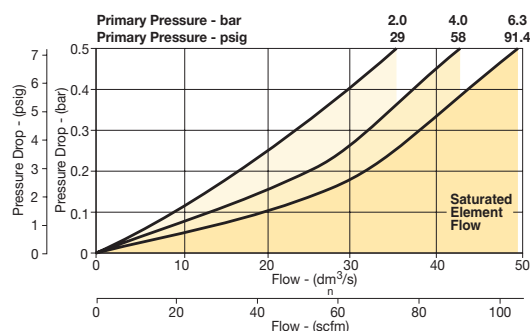

P33FA - 0.01 micron flow

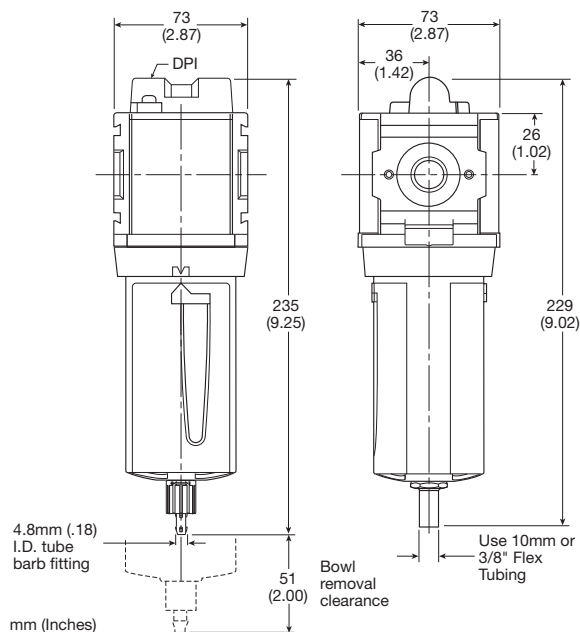
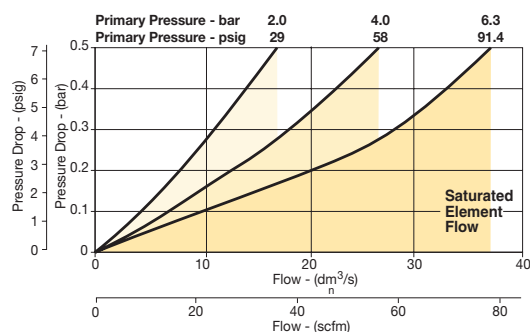

Manual Drain

Automatic Drain



P31 Regulators – Mini

- Integral 1/4" ports (NPT, BSPP & BSPT)
- Robust but lightweight aluminum construction
- Secondary pressure ranges
- Secondary aspiration plus balanced poppet provides quick response and accurate pressure regulation.
- Relieving & non-relieving types
- Non-rising knob

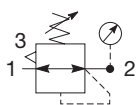

Self relieving regulator with gauge

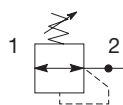

Non-relieving regulator

Port Size	Description (relieving)	Gauge	Part Number
1/4"	125 psig (8 bar)	None	P31RB12BNNP
1/4"	125 psig (8 bar)	Square	P31RB12BNTP

Operating Information

Flow capacity*:	1/4	68 scfm (32 dm ³ /s, ANR)
Operating temperature†:		-4°F to 150°F (-20°C to 65.5°C)
Supply pressure (max):		300 psig (20 bar)
Adjusting range pressure:		30 psig (0-2 bar) 60 psig (0-4 bar) 125 psig (0-8 bar) 232 psig (0-16 bar)
Gauge port (2 each)**		1/8 BSPP, BSPT, NPT
Weight:		0.37 lb (0.17 kg)

* Inlet pressure 145 psig (10 bar). Secondary pressure 91.3 psig (6.3 bar) and 14.5 psig (1 bar) pressure drop.
** Non-gauge option only.
† Units with square gauges: 5°F to 150°F (-15°C to 65.5°C)

Ordering Information:

P31RB 1 2 B N T P

Basic Series

Global Modular Mini Regulator **P31RB**

Thread Type

BSPP	1
BSPT	2
NPT	9

Port Size

1/4	2
-----	---

Relief

Relieving	B
Non-Relieving	N
Reverse Flow-Relieving	R

Mounting

P Plastic Panel Mount Nut

Adjustment

N Non-rising knob

Adjustment Range			
With Square Gauge		With Round Gauge	
psig	bar	Z	M
1 = 30*	V = 2*	30 psig; 2 bar; 0.2 MPa	60 psig; 4 bar; 0.4 MPa
3 = 60	S = 4	60 psig; 4 bar; 0.4 MPa	125 psig; 8 bar; 0.8 MPa
5 = 125	T = 8	125 psig; 8 bar; 0.8 MPa	232 psig; 16 bar; 1.6 MPa

* Regulator comes with gauge respective to the adjustment range selected.

Without Gauge	
Y	L
30 psig; 2 bar; 0.2 MPa	60 psig; 4 bar; 0.4 MPa
125 psig; 8 bar; 0.8 MPa	232 psig; 16 bar; 1.6 MPa

Options in grey boxes are not available or not stocked in EMEA region

Material Specifications

Body	Aluminum
Adjustment knob	Acetal
Bonnet	PBT
Diaphragm assembly	Brass / Nitrile
Valve assembly	Brass / Nitrile
Springs	Steel
Seals	Nitrile
Panel nut	Acetal

Repair and Service Kits

Diaphragm repair kit - relieving	P31KB00RB
Diaphragm repair kit - non-relieving	P31KB00RC
Panel mount nut - aluminum	P31KA00MM
Panel mount nut - plastic	P31KA00MP
Angle bracket (attaches via panel nut)	P31KB00MR
C-bracket (fits to body)	P31KA00MW
T-bracket with body connector	P31KA00MT
Body connector	P31KA00CB

Flow Charts

P31RB 1/4" Regulator

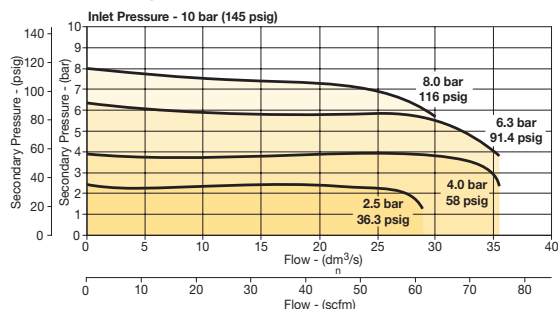

WARNING

**Product rupture can cause serious injury.
Do not connect regulator to bottled gas.
Do not exceed Maximum primary pressure rating.**

CAUTION:

REGULATOR PRESSURE ADJUSTMENT – The working range of knob adjustment is designed to permit outlet pressures within their full range. Pressure adjustment beyond this range is also possible because the knob is not a limiting device. This is a common characteristic of most industrial regulators, and limiting devices may be obtained only by special design. For best performance, regulated pressure should always be set by increasing the pressure up to the desired setting.

Gauges

Square flush mount gauge	0-4 bar	K4511SCR04B
	0-11 bar	K4511SCR11B
	0-60 psig	K4511SCR060
	0-160 psig	K4511SCR160
Square with adapter kit	0-4 bar	P6G-PR10040
	0-11 bar	P6G-PR10110
	0-60 psig	P6G-PR90060
	0-160 psig	P6G-PR90160
40mm Round 1/8" center back mount	0-60 psig / 0-4 bar	P3D-KAB1ALN
	0-140 psig / 0-10 bar	P3D-KAB1ANN
	0-300 psig / 0-20 bar	P3D-KAB1AHN

For best performance, regulated pressure should always be set by increasing the pressure up to the desired setting.

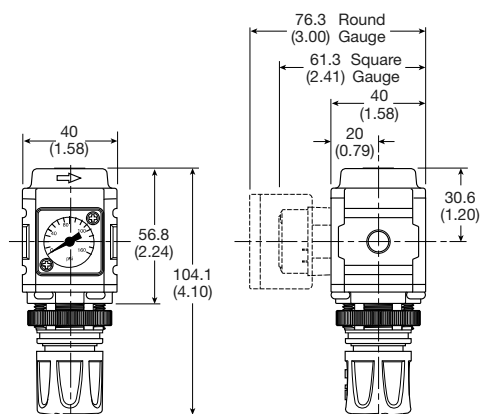

mm (Inches)

NOTE: 1.20 in. (30mm) hole required for panel nut mounting.

P31 Common P1 Regulators – Mini

- Manifold style regulator with line pressure on both sides
- Pressure output is at front or rear
- Inlet port 1/4" (NPT, BSPP & BSPT)
- Working port 1/8"
- Robust construction
- Secondary pressure ranges
- Secondary aspiration plus balanced poppet provides quick response and accurate pressure regulation
- Relieving & non-relieving types
- Non-rising knob

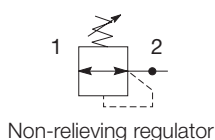
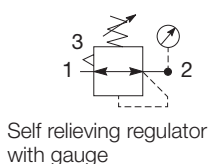
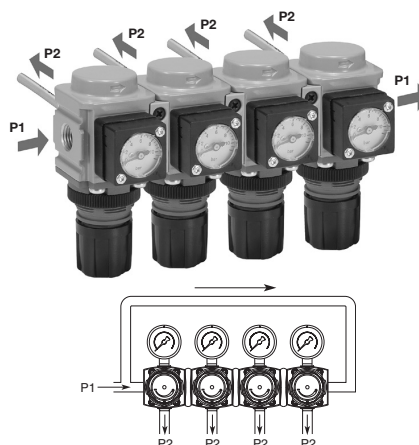

Port Size	Description (relieving)	Gauge	Part Number
1/4"	125 psig (8 bar)	None	P31HB12BNNP
1/4"	125 psig (8 bar)	Square	P31HB12BNTP

Operating Information

Flow capacity*:	1/4	42 scfm (20 dm ³ /s, ANR)
Operating temperature:		-4°F to 150°F (-20°C to 65.5°C)
Supply pressure (max):		300 psig (20 bar)
Adjusting range pressure:		30 psig (0-2 bar) 60 psig (0-4 bar) 125 psig (0-8 bar) 232 psig (0-16 bar)
P1 port size (inlet/outlet)		1/4 NPT, BSPP, BSPT
P2 regulated ports (2 ea.)		1/8 NPT, BSPP, BSPT
Weight:		0.66 lb (0.30 kg)

* Inlet pressure 145 psig (10 bar). Secondary pressure 91.3 psig (6.3 bar) and 14.5 psig (1 bar) pressure drop.

Ordering Information:

P31HB		1	2	B	N	T	P			
Basic Series	Global Modular Mini Common Regulator	P31HB	Thread Type	BSPP 1 BSPT 2 NPT 9	Port Size †	1/4 2	Relief	Relieving B Non-Relieving N	Mounting	P Plastic Panel Mount Nut
										Adjustment Range
										With Square Gauge
										With Round Gauge
										Without Gauge
										Adjustment
										Non-Rising Knob

† Working port 1/8".

* Regulator comes with gauge respective to the adjustment range selected.

Options in grey boxes are not available or not stocked in EMEA region

PDE2676TCUK
Global FRL and P3Y Series

P31, P32, P33 Series
Mini Common P1 Regulators

Materials of Construction

Body	Aluminum
Adjustment knob	Acetal
Bonnet	Glass-filled PBT
Diaphragm assembly	Brass / Nitrile
Valve assembly	Brass / Nitrile

Repair and Service Kits

Diaphragm repair kit - relieving	P31KB00RB
Diaphragm repair kit - non-relieving	P31KB00RC
Panel mount nut - aluminum	P31KA00MM
Panel mount nut - plastic	P31KA00MP
Angle bracket (attaches via panel nut)	P31KB00MR
T-bracket with body connector	P31KA00MT
Body connector	P31KA00CB

Flow Charts

P31HB 1/4" Common Regulator

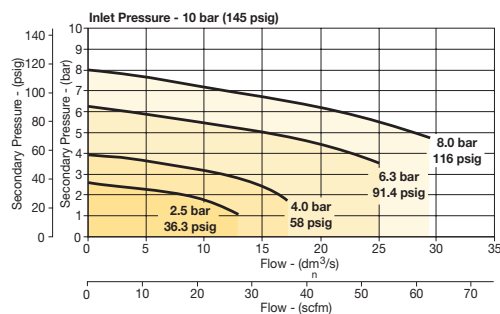

⚠ WARNING

**Product rupture can cause serious injury.
 Do not connect regulator to bottled gas.
 Do not exceed Maximum primary pressure rating.**

CAUTION:

REGULATOR PRESSURE ADJUSTMENT – The working range of knob adjustment is designed to permit outlet pressures within their full range. Pressure adjustment beyond this range is also possible because the knob is not a limiting device. This is a common characteristic of most industrial regulators, and limiting devices may be obtained only by special design. For best performance, regulated pressure should always be set by increasing the pressure up to the desired setting.

Gauges

Square with adapter kit	0-4 bar	P6G-PR10040
	0-11 bar	P6G-PR10110
	0-60 psig	P6G-PR90060
	0-160 psig	P6G-PR90160
40mm Round 1/8" center back mount	0-60 psig / 0-4 bar	P3D-KAB1ALN
	0-140 psig / 0-10 bar	P3D-KAB1ANN
	0-300 psig / 0-20 bar	P3D-KAB1AHN

For best performance, regulated pressure should always be set by increasing the pressure up to the desired setting.

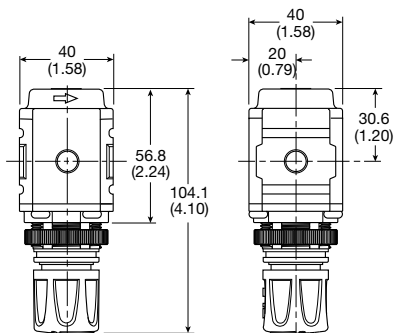

mm (Inches)

NOTE: 1.20 in. (30mm) hole required for panel nut mounting.

P32 Regulators – Compact

- Integral 1/4", 3/8" or 1/2" ports (NPT, BSPP & BSPT)
- Robust but lightweight aluminum construction
- Secondary pressure ranges
- Secondary aspiration plus balanced poppet provides quick response and accurate pressure regulation
- Relieving & non-relieving types
- Regulator will reverse flow as standard
- Non-rising knob
- Available T-handle

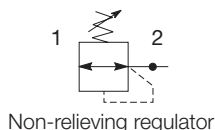
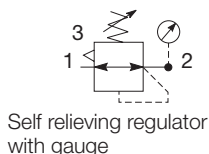

Port Size	Description (relieving)	Gauge	Part Number
1/4"	125 psig (8 bar)	None	P32RB12BNNP
1/4"	125 psig (8 bar)	Round	P32RB12BNGP
3/8"	125 psig (8 bar)	None	P32RB13BNNP
3/8"	125 psig (8 bar)	Round	P32RB13BNGP
1/2"	125 psig (8 bar)	None	P32RB14BNNP
1/2"	125 psig (8 bar)	Round	P32RB14BNGP

Operating Information

Flow capacity*:	
1/4	148 scfm (70 dm ³ /s, ANR)
3/8, 1/2	165 scfm (78 dm ³ /s, ANR)
Operating temperature:	-13°F to 150°F (-25°C to 65.5°C)
Supply pressure (max):	300 psig (20 bar)
Adjusting range pressure:	30 psig (0-2 bar) 60 psig (0-4 bar) 125 psig (0-8 bar) 250 psig (0-17 bar)
Gauge port (2 each)	1/4 NPT, BSPP, BSPT
Weight:	0.90 lb (0.41 kg)
* Inlet pressure 145 psig (10 bar). Secondary pressure 91.3 psig (6.3 bar) and 14.5 psig (1 bar) pressure drop.	

Ordering Information:

P32RB		1	3	B	N	G	P																						
Basic Series	Global Modular Compact Regulator	P32RB	Thread Type	BSPP 1 BSPT 2 NPT 9	Port Size	1/4 2 3/8 3 1/2 4	Relief	Relieving B Non-Relieving N	Mounting	P Plastic Panel Mount Nut																			
								Adjustment Range																					
								<table border="1"> <thead> <tr> <th colspan="2">With Square Gauge</th> <th colspan="2">With Round Gauge</th> </tr> <tr> <th>psig</th> <th>bar</th> <th>Z</th> <th>M</th> </tr> </thead> <tbody> <tr> <td>1 = 30*</td> <td>V = 2*</td> <td>G</td> <td>J</td> </tr> <tr> <td>3 = 60</td> <td>S = 4</td> <td></td> <td></td> </tr> <tr> <td>5 = 125</td> <td>T = 8</td> <td></td> <td></td> </tr> </tbody> </table>		With Square Gauge		With Round Gauge		psig	bar	Z	M	1 = 30*	V = 2*	G	J	3 = 60	S = 4			5 = 125	T = 8		
With Square Gauge		With Round Gauge																											
psig	bar	Z	M																										
1 = 30*	V = 2*	G	J																										
3 = 60	S = 4																												
5 = 125	T = 8																												
								<table border="1"> <thead> <tr> <th colspan="2">Without Gauge</th> </tr> <tr> <th></th> <th></th> </tr> </thead> <tbody> <tr> <td>Y</td> <td>30 psig; 2 bar; 0.2 MPa</td> </tr> <tr> <td>L</td> <td>60 psig; 4 bar; 0.4 MPa</td> </tr> <tr> <td>N</td> <td>125 psig; 8 bar; 0.8 MPa</td> </tr> <tr> <td>H</td> <td>250 psig; 17 bar; 1.7 MPa</td> </tr> </tbody> </table>		Without Gauge				Y	30 psig; 2 bar; 0.2 MPa	L	60 psig; 4 bar; 0.4 MPa	N	125 psig; 8 bar; 0.8 MPa	H	250 psig; 17 bar; 1.7 MPa								
Without Gauge																													
Y	30 psig; 2 bar; 0.2 MPa																												
L	60 psig; 4 bar; 0.4 MPa																												
N	125 psig; 8 bar; 0.8 MPa																												
H	250 psig; 17 bar; 1.7 MPa																												
						Adjustment		<table border="1"> <tbody> <tr> <td>N</td> <td>Non-Rising Knob</td> </tr> <tr> <td>T</td> <td>T-Handle</td> </tr> </tbody> </table>		N	Non-Rising Knob	T	T-Handle																
N	Non-Rising Knob																												
T	T-Handle																												
* Regulator comes with gauge respective to the adjustment range selected.																													
Options in grey boxes are not available or not stocked in EMEA region																													

Material Specifications

Body	Aluminum
Adjustment knob	Acetal
Bonnet	Glass-filled nylon
Diaphragm assembly	Nitrile / Zinc
Valve assembly	Brass / Nitrile
Springs	Steel, stainless steel
Seals	Nitrile
Panel nut	Acetal

Repair and Service Kits

Diaphragm repair kit - relieving	P32KB00RB
Diaphragm repair kit - non-relieving	P32KB00RC
Panel mount nut - aluminum	P32KA00MM
Panel mount nut - plastic	P32KA00MP
Angle bracket (attaches via panel nut)	P32KB00MR
T-bracket with body connector	P32KA00MT
T-bracket	P32KA00MB
Body connector	P32KA00CB



WARNING

Product rupture can cause serious injury.
Do not connect regulator to bottled gas.
Do not exceed Maximum primary pressure rating.

CAUTION:

REGULATOR PRESSURE ADJUSTMENT – The working range of knob adjustment is designed to permit outlet pressures within their full range. Pressure adjustment beyond this range is also possible because the knob is not a limiting device. This is a common characteristic of most industrial regulators, and limiting devices may be obtained only by special design. For best performance, regulated pressure should always be set by increasing the pressure up to the desired setting.

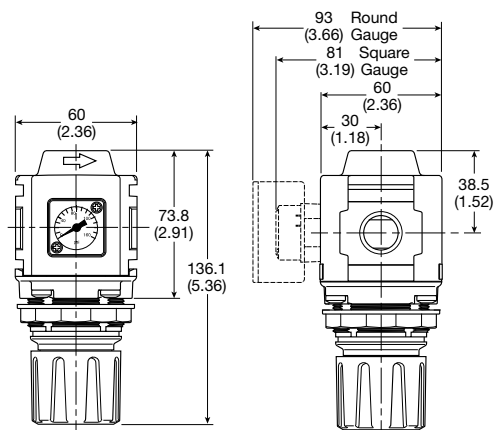

mm (Inches)

NOTE: 1.90 in. (48mm) hole required for panel nut mounting.

Flow Charts

P32RB 1/4" Regulator

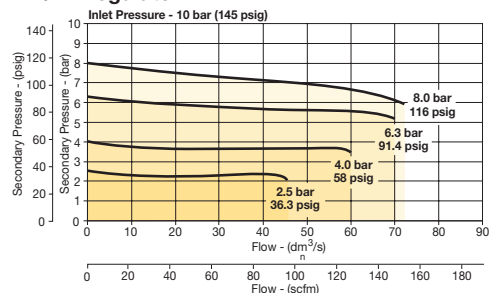

P32RB 3/8" Regulator

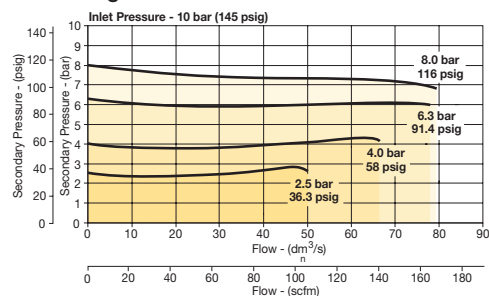

P32RB 1/2" Regulator

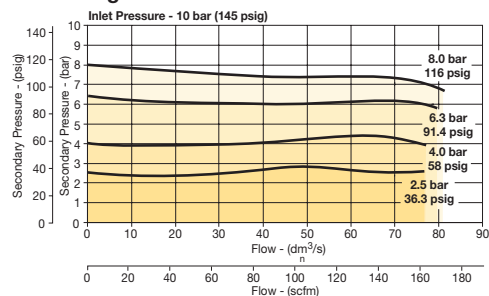

Gauges

Square flush mount gauge	0-4 bar	K4511SCR04B
	0-11 bar	K4511SCR11B
	0-60 psig	K4511SCR060
	0-160 psig	K4511SCR160
Square with adapter kit	0-4 bar	P6G-PR10040
	0-11 bar	P6G-PR10110
	0-60 psig	P6G-PR90060
	0-160 psig	P6G-PR90160
50mm (2") round 1/4" center back mount	0-60 psig / 0-4 bar	P6G-ERB2040
	0-160 psig / 0-11 bar	P6G-ERB2110
	0-300 psig / 0-20 bar	P6G-ERB2200

For best performance, regulated pressure should always be set by increasing the pressure up to the desired setting.

P32 Semi-Precision Regulator – Compact

- Integral 1/4", 3/8" or 1/2" ports (NPT, BSPP & BSPT)
- Robust but lightweight aluminum construction
- Secondary pressure ranges
- Secondary aspiration plus balanced poppet provides quick response and accurate pressure regulation
- Relieving & non-relieving types
- Regulator will reverse flow as standard
- Non-rising knob

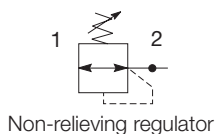
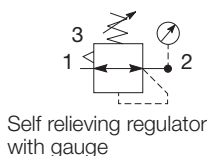

Port Size	Description (relieving)	Gauge	Part Number
1/4"	125 psig (8 bar)	None	P32RB12PNNP
1/4"	125 psig (8 bar)	Round	P32RB12PNGP
3/8"	125 psig (8 bar)	None	P32RB13PNNP
3/8"	125 psig (8 bar)	Round	P32RB13PNGP
1/2"	125 psig (8 bar)	None	P32RB14PNNP
1/2"	125 psig (8 bar)	Round	P32RB14PNGP

Operating Information

Flow capacity*:	1/4, 3/8, 1/2	53 scfm (25 dm ³ /s, ANR)
Effect of supply pressure variation		0.6 psig (0.04 bar) for 25 psig (1.7 bar) change in P1
Operating temperature:		-13°F to 150°F (-25°C to 65.5°C)
Supply pressure (max):		300 psig (20 bar)
Adjusting range pressure:		0 to 30 psig (0 to 2 bar) 0 to 60 psig (0 to 4 bar) 0 to 125 psig (0 to 8 bar) 0 to 250 psig (0 to 17 bar)
Gauge port (2 each):		1/4 NPT, BSPP, BSPT
Weight:		0.90 lb (0.41 kg)
* Inlet pressure 145 psig (10 bar). Secondary pressure 91.3 psig (6.3 bar) and 14.5 psig (1 bar) pressure drop.		

Ordering Information:

Basic Series		Thread Type		Port Size		Relief		Mounting		Adjustment Range		Adjustment	
Global Modular Compact Regulator	P32RB	BSPP	1	1/4	2	Semi-Precision Relieving	P	Plastic Panel Mount Nut	P	With Square Gauge	With Round Gauge	Non-Rising Knob	N
		BSPT	2	3/8	3	Semi-Precision Non-Relieving	T			psig	bar	T-Handle	T
		NPT	9	1/2	4					1 = 30*	V = 2*		
										3 = 60	S = 4		
										5 = 125	T = 8		
										* Regulator comes with gauge respective to the adjustment range selected.			
										Without Gauge			
										Z	30 psig; 2 bar; 0.2 MPa		
										M	60 psig; 4 bar; 0.4 MPa		
										G	125 psig; 8 bar; 0.8 MPa		
										J	250 psig; 17 bar; 1.7 MPa		
										Y	30 psig; 2 bar; 0.2 MPa		
										L	60 psig; 4 bar; 0.4 MPa		
										N	125 psig; 8 bar; 0.8 MPa		
										H	250 psig; 17 bar; 1.7 MPa		

Options in grey boxes are not available or not stocked in EMEA region

Material Specifications

Body	Aluminum
Adjustment knob	Acetal
Bonnet	Glass-filled nylon
Diaphragm assembly	Nitrile / zinc
Valve assembly	Brass / nitrile
Springs	Steel, stainless steel
Seals	Nitrile
Panel nut	Acetal

Repair and Service Kits

Diaphragm repair kit - relieving	P32KB00RB
Diaphragm repair kit - non-relieving	P32KB00RC
Panel mount nut - aluminum	P32KA00MM
Panel mount nut - plastic	P32KA00MP
Angle bracket (attaches via panel nut)	P32KB00MR
T-bracket with body connector	P32KA00MT
T-bracket	P32KA00MB
Body connector	P32KA00CB

⚠ WARNING

**Product rupture can cause serious injury.
Do not connect regulator to bottled gas.
Do not exceed Maximum primary pressure rating.**

CAUTION:

REGULATOR PRESSURE ADJUSTMENT – The working range of knob adjustment is designed to permit outlet pressures within their full range. Pressure adjustment beyond this range is also possible because the knob is not a limiting device. This is a common characteristic of most industrial regulators, and limiting devices may be obtained only by special design. For best performance, regulated pressure should always be set by increasing the pressure up to the desired setting.

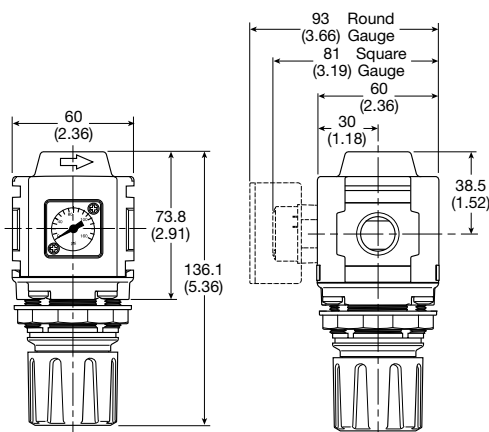

mm (Inches)

NOTE: 1.90 in. (48mm) hole required for panel nut mounting.

Flow Charts

P32RB 1/4" Regulator

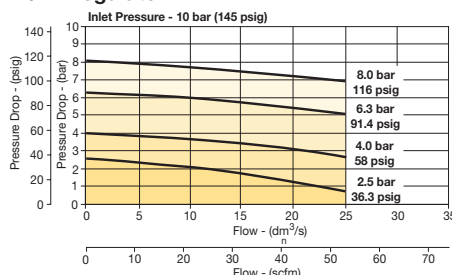

P32RB 3/8" Regulator

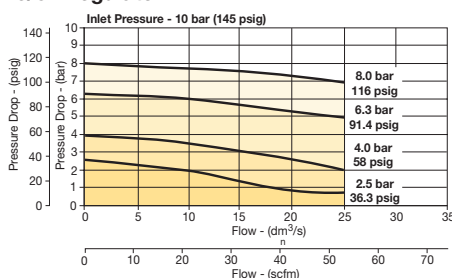

P32RB 1/2" Regulator

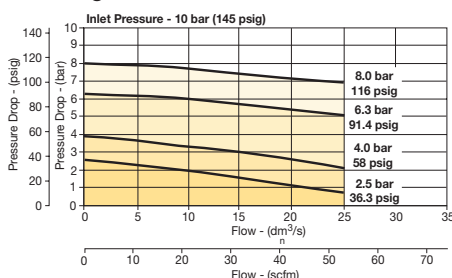

Gauges

Square flush mount gauge	0-4 bar	K4511SCR04B
	0-11 bar	K4511SCR11B
	0-60 psig	K4511SCR060
	0-160 psig	K4511SCR160
Square with adapter kit	0-4 bar	P6G-PR10040
	0-11 bar	P6G-PR10110
	0-60 psig	P6G-PR90060
	0-160 psig	P6G-PR90160
50mm (2") round 1/4" center back mount	0-60 psig / 0-4 bar	P6G-ERB2040
	0-160 psig / 0-11 bar	P6G-ERB2110
	0-300 psig / 0-20 bar	P6G-ERB2200

For best performance, regulated pressure should always be set by increasing the pressure up to the desired setting.



P32 Common - P1 Regulator – Compact

- Manifold style regulator with line pressure on both sides.
- Pressure output is at front or rear.
- Inlet ports 1/4", 3/8" or 1/2" (NPT, BSPP & BSPT)
- Working port 1/4"
- Robust construction
- Secondary pressure ranges
- Secondary aspiration plus balanced poppet provides quick response and accurate pressure regulation
- Relieving & non-relieving types
- Regulator will reverse flow as standard
- Non-rising knob

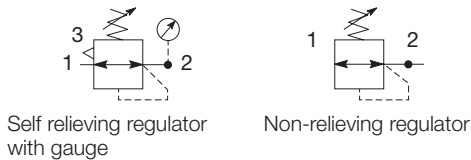
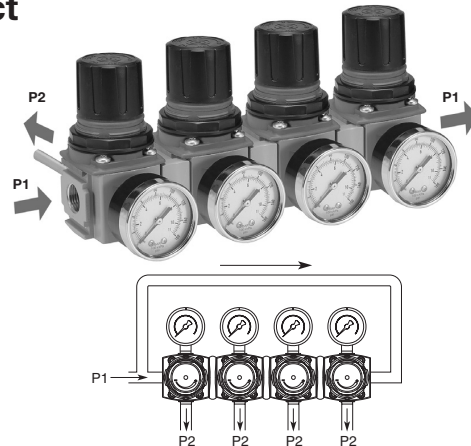

Port Size	Description (relieving)	Gauge	Part Number
1/4"	125 psig (8 bar)	None	P32HB12BNNP
3/8"	125 psig (8 bar)	None	P32HB13BNNP
1/2"	125 psig (8 bar)	None	P32HB14BNNP

Operating Information

Flow capacity*:	1/4, 3/8, 1/2	64 scfm (30 dm ³ /s, ANR)
Operating temperature:		-25°C to 65.5°C (-13°F to 150°F)
Supply pressure (max):		300 psig (20 bar)
Adjusting range pressure:		0 to 30 psig (0 to 2 bar) 0 to 60 psig (0 to 4 bar) 0 to 125 psig (0 to 8 bar) 0 to 232 psig (0 to 16 bar)
Gauge port (2 each):		1/4 NPT, BSPP, BSPT
Weight:		0.50 lb (0.23 kg)

* Inlet pressure 145 psig (10 bar). Secondary pressure 91.3 psig (6.3 bar) and 14.5 psig (1 bar) pressure drop.

Ordering Information:

Basic Series		Thread Type		Port Size †		Relief		Adjustment		Mounting		Adjustment Range			
Global Modular Compact Regulator	P32HB	BSPP	1	1/4	2	Relieving	B	N	Non-Rising Knob	P	Plastic Panel Mount Nut	With Square Gauge		With Round Gauge	
		BSPT	2	3/8	3	Non-Relieving	N	T	T-Handle			psig	bar	Z	30 psig; 2 bar; 0.2 MPa
		NPT	9	1/2	4							1 = 30*	V = 2*	M	60 psig; 4 bar; 0.4 MPa
												3 = 60	S = 4	G	125 psig; 8 bar; 0.8 MPa
												5 = 125	T = 8	J	250 psig; 17 bar; 1.7 MPa
												Without Gauge			
														Y	30 psig; 2 bar; 0.2 MPa
														L	60 psig; 4 bar; 0.4 MPa
														N	125 psig; 8 bar; 0.8 MPa
														H	250 psig; 17 bar; 1.7 MPa

Options in grey boxes are not available or not stocked in EMEA region

† Working port 1/4".

* Regulator comes with gauge respective to the adjustment range selected.

PDE2676TCUK
Global FRL and P3Y Series

P31, P32, P33 Series
Compact Common P1 Precision Regulator

Material Specifications

Body	Aluminum
Adjustment knob	Acetal
Bonnet	Glass-filled nylon
Diaphragm assembly	Nitrile / zinc
Valve assembly	Brass / nitrile
Springs	Steel, stainless steel
Seals	Nitrile
Panel nut	Acetal

Repair and Service Kits

Diaphragm repair kit - relieving	P32KB00RB
Diaphragm repair kit - non-relieving	P32KB00RC
Panel mount nut - aluminum	P32KA00MM
Panel mount nut - plastic	P32KA00MP
Angle bracket (attaches via panel nut)	P32KB00MR
T-bracket with body connector	P32KA00MT
T-bracket	P32KA00MB
Body connector	P32KA00CB

Flow Charts

P32HB Common Port Regulator

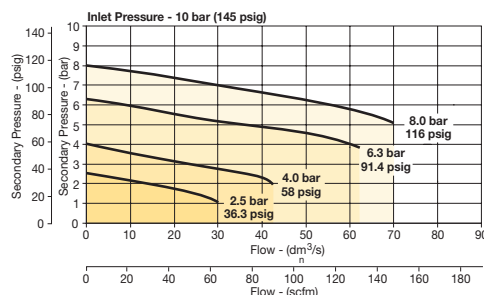

⚠ WARNING

**Product rupture can cause serious injury.
 Do not connect regulator to bottled gas.
 Do not exceed Maximum primary pressure rating.**

CAUTION:

REGULATOR PRESSURE ADJUSTMENT – The working range of knob adjustment is designed to permit outlet pressures within their full range. Pressure adjustment beyond this range is also possible because the knob is not a limiting device. This is a common characteristic of most industrial regulators, and limiting devices may be obtained only by special design. For best performance, regulated pressure should always be set by increasing the pressure up to the desired setting.

Gauges

Square flush mount gauge	0-4 bar	K4511SCR04B
	0-11 bar	K4511SCR11B
	0-60 psig	K4511SCR060
	0-160 psig	K4511SCR160
Square with adapter kit	0-4 bar	P6G-PR10040
	0-11 bar	P6G-PR10110
	0-60 psig	P6G-PR90060
	0-160 psig	P6G-PR90160
50mm (2") round 1/4" center back mount	0-60 psig / 0-4 bar	P6G-ERB2040
	0-160 psig / 0-11 bar	P6G-ERB2110
	0-300 psig / 0-20 bar	P6G-ERB2200

For best performance, regulated pressure should always be set by increasing the pressure up to the desired setting.

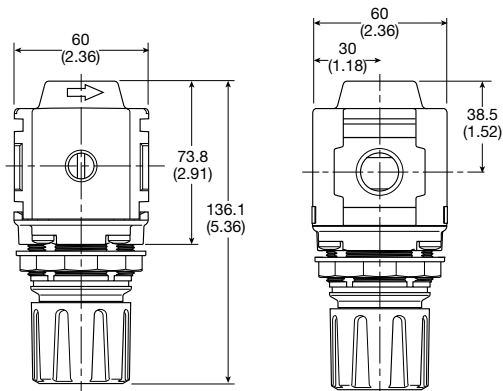

mm (Inches)

NOTE: 1.90 in. (48mm) hole required for panel nut mounting.

Most popular.



P33 Regulators – Standard

- Integral 1/2" or 3/4" ports (NPT, BSPP & BSPT)
- Robust but lightweight aluminum construction
- Secondary pressure ranges
- Secondary aspiration plus balanced poppet provides quick response and accurate pressure regulation
- Relieving & non-relieving types
- Non-rising knob

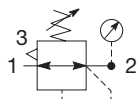

Self relieving regulator with gauge

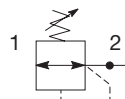

Non-relieving regulator

Port Size	Description (relieving)	Gauge	Part Number
1/2"	125 psig (8 bar)	None	P33RA14BNNP
1/2"	125 psig (8 bar)	Round	P33RA14BNGP
3/4"	125 psig (8 bar)	None	P33RA16BNNP
3/4"	125 psig (8 bar)	Round	P33RA16BNGP

Operating Information

Flow capacity*:	1/2, 3/4	233 scfm (110 dm ³ /s, ANR)
Operating temperature:		-13°F to 150°F (-25°C to 65.5°C)
Supply pressure (max):		300 psig (20 bar)
Adjusting range pressure:		0 to 30 psig (0 to 2 bar) 0 to 60 psig (0 to 4 bar) 0 to 125 psig (0 to 8 bar) 0 to 250 psig (0 to 17 bar)
Gauge port (2 each):		1/4 NPT, BSPP, BSPT
Weight:		1.37 lb (0.62 kg)

* Inlet pressure 145 psig (10 bar). Secondary pressure 91.3 psig (6.3 bar) and 14.5 psig (1 bar) pressure drop.

Ordering Information:

P33RA 1 6 B N G P

Basic Series Global Modular Standard Regulator P33RA	Thread Type BSPP 1 BSPT 2 NPT 9	Port Size 1/2 4 3/4 6	Relief Relieving B Non-Relieving N Reverse Flow-Relieving R	Adjustment Non-Rising Knob N	Mounting P Plastic Panel Mount Nut
-------------------------------------------------------------------	-------------------------------------------------	------------------------------------	-----------------------------------------------------------------------------	----------------------------------------	----------------------------------------------

Adjustment Range	
With Round Gauge	
Z	30 psig; 2 bar; 0.2 MPa
M	60 psig; 4 bar; 0.4 MPa
G	125 psig; 8 bar; 0.8 MPa
J	250 psig; 17 bar; 1.7 MPa
Without Gauge	
Y	30 psig; 2 bar; 0.2 MPa
L	60 psig; 4 bar; 0.4 MPa
N	125 psig; 8 bar; 0.8 MPa
H	250 psig; 17 bar; 1.7 MPa

Options in grey boxes are not available or not stocked in EMEA region

Material Specifications

Body	Aluminum
Adjustment knob	Acetal
Body cap	ABS
Bonnet	Glass-filled nylon
Diaphragm assembly	Nitrile / zinc
Valve assembly	Brass / nitrile
Springs	Steel, stainless steel
Seals	Nitrile
Panel nut	Acetal

Repair and Service Kits

Diaphragm repair kit - relieving	P33KA00RB
Diaphragm repair kit - non-relieving	P33KA00RC
Panel mount nut - aluminum	P33KA00MM
Panel mount nut - plastic	P33KA00MP
Angle bracket (attaches via panel nut)	P33KA00MR
T-bracket with body connector	P32KA00MT
T-bracket	P32KA00MB
Body connector	P32KA00CB

⚠ WARNING

**Product rupture can cause serious injury.
Do not connect regulator to bottled gas.
Do not exceed Maximum primary pressure rating.**

CAUTION:

REGULATOR PRESSURE ADJUSTMENT – The working range of knob adjustment is designed to permit outlet pressures within their full range. Pressure adjustment beyond this range is also possible because the knob is not a limiting device. This is a common characteristic of most industrial regulators, and limiting devices may be obtained only by special design. For best performance, regulated pressure should always be set by increasing the pressure up to the desired setting.

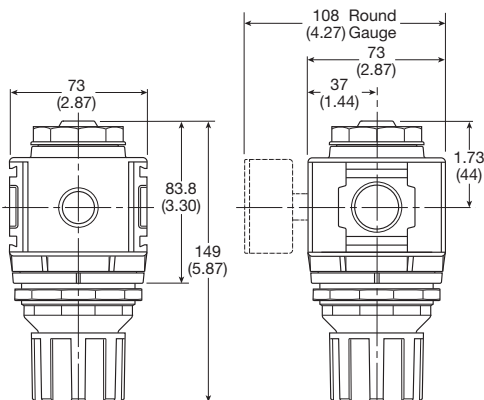

mm (Inches)

NOTE: 2.40 in. (61mm) hole required for panel nut mounting.

Flow Charts

P33RA 1/2" Regulator

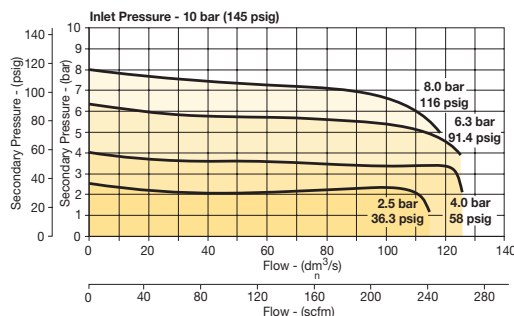

P33RA 3/4" Regulator

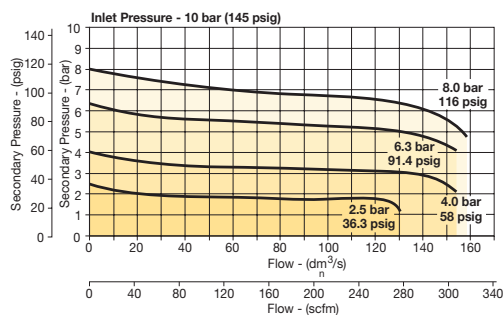

Gauges

50mm (2") round	0-60 psig / 0-4 bar	P6G-ERB2040
1/4" center back mount	0-160 psig / 0-11 bar	P6G-ERB2110
	0-300 psig / 0-20 bar	P6G-ERB2240

For best performance, regulated pressure should always be set by increasing the pressure up to the desired setting.



P31P & P32P Proportional Regulators

- Very fast response times
- Accurate output pressure
- Parameter settings
- Selectable I/O parameters
- Quick, full flow exhaust
- LED display indicates output pressure
- No air consumption in steady state
- Multiple mounting options
- Protection to IP65



P31P Series
Bottom exhaust



P32P Series
Bottom exhaust

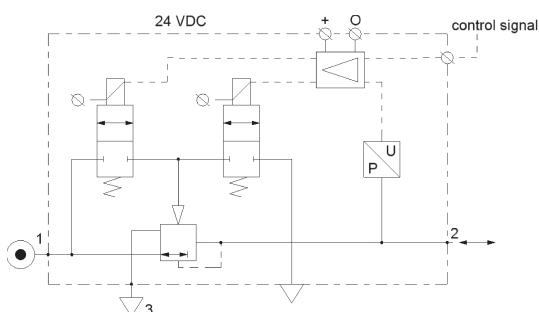

Port Size	Description	Part Number
1/4"	145 psig (0-10 bar), NC 0-10V	P31PA12AD2VD1A
1/2"	145 psig (0-10 bar), NC 0-10V	P32PA14AD2VD1A

Operating Information

Flow capacity*:	P31P	40 scfm (19 dm ³ /s, ANR)
	P32P	120 scfm (57 dm ³ /s, ANR)
Temperature range:	32°F to 122°F (0°C to 50°C)	
Supply pressure (max):	2 bar unit 36.3 psig (2.5 bar)	
	10 bar unit 152 psig (10.5 bar)	
Operating pressure (min):	P2 pressure + 7.3 psig (0.5 bar)	
Working medium:	Compressed air or inert gasses, filtered to 40µ	
Pressure range:	0 to 30 psig (0 to 2 bar)	
	0 to 145 psig (0 to 10 bar)	
Weight:	P31P	0.64 lb (0.291 kg)
	P32P	1.42 lb (0.645 kg)

* Inlet pressure 91.3 psig (6.3 bar), inlet pressure and 4.9 psig (0.34 bar) pressure drop.

Ordering Information:

Body Size		Thread Type		Power Supply		Control Signal		Input Connector	
Global Modular Mini (1/4")	P31PA	BSPP	1	2	24 volts	V	0-10V [‡]	1	M12 (4-pin)
Global Modular Compact (1/2")	P32PA	NPT	9			A	4 - 20mA		
Port Size		Version		Pressure Range		Output Signal			
Global Modular Mini (1/4")	2	Bottom Ported Exhaust (NC)	A	Z	0 - 2 bar (0-29 PSIG)	D	Digital, PNP		
Global Modular Compact (1/2")	4	Bottom Ported Forced Exhaust (NO) [†]	E	S	0 - 7 Bar (0-101 PSIG)	P	PNP or 0-10V		
		Side Ported Exhaust (NC)	B	D	0 - 10 bar (0-145 PSIG)	N	NPN or 0-10V		
		Side Ported Forced Exhaust (NO) [†]	C			M	4-20mA Fixed		

Options in grey boxes are not available or not stocked in EMEA region

[†] When the supply voltage is lost the unit will automatically exhaust the regulated pressure to 0 bar (atmospheric pressure)

[‡] Factory setting is 0-10 V control signal. 4-20 mA control signal available via parameter 4 on keypad.

D) Digital PNP output only, no analog output selectable
P) Digital PNP and analogue 0-10V outputs selectable, by means of parameter 6. (Factory default 0-10V)
N) Digital NPN and analog 0-10 V outputs selectable by means of parameter 6. (Factory default 0-10V)
M) Analog 4-20mA output only.
Note: On all analog outputs the F.S. value can be adjusted by means of parameter 8.

Technical Information

Accuracy

+/- 1.0% of F.S.*

* Full scale (F.S.) - For 2 bar (29 psig) versions this will be 2 bar (29 psig), for the 10 bar (145 psig) version full scale will be 10 bar (145 psig).

Air consumption

No consumption in stable regulated situation.

Display

The regulator is provided with a digital display, indicating the output pressure, either in bar or psig.

The factory setting is as indicated on the label, can be changed through to software at all times (parameter 14)

Supply voltage

24 VDC +/- 10%

Power consumption

Max. 1.1W with unloaded signal outputs

Control signals

The electronic pressure regulator can be externally controlled through an analogue control signal of either 0-10V or 4-20mA. (parameter 4).

Output signals

As soon as the output pressure is within the signal band a signal is given of 24VDC, PNP Ri = 1 kOhm
 Outside the signal band this connection is 0V.

Connections

(In case of output signal (Option D)

Central M12 connector 4-pole

The electrical connections are as follows:

Pin No.	Function	Color
1	24 V Supply	Brown
2	0 to 10 V Control Signal Ri = 100k Ω 4 to 20mA Control Signal Ri = 500 Ω	White
3	0 V (GND) Supply & Set Point Ground	Blue
4	24 V Alarm Output Signal	Black

Flow Charts

P31P Regulator 1/4" Ports

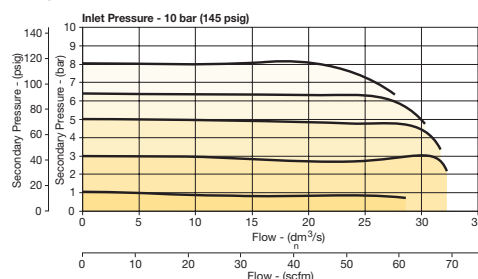

P32P Regulator 1/2" Ports

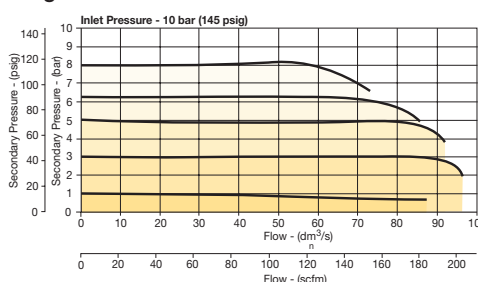

Degree of protection: IP65

EU conformity

CE: standard

EMC: according to directive 89/336/EEC

This pressure regulator is in accordance with:

EN 61000-6-1:2001 **EN 61000-6-2:2001**
EN 61000-6-3:2001 **EN 61000-6-4:2001**

Mounting position

Preferably vertical, with the cable gland on top.

Materials: P31P & P32P

Magnet core	Steel
Solenoid valve poppet	FPM
Solenoid valve housing	Techno polymer
Regulator body (P31P & P32P versions)	Aluminum
Regulator top housing	Nylon
Valve head	Brass & NBR
Remaining seals	NBR

PDE2676TCUK

Global FRL and P3Y Series

**P31, P32, P33 Series
Dimensional Data**

P31P

Dimensions inches (mm)

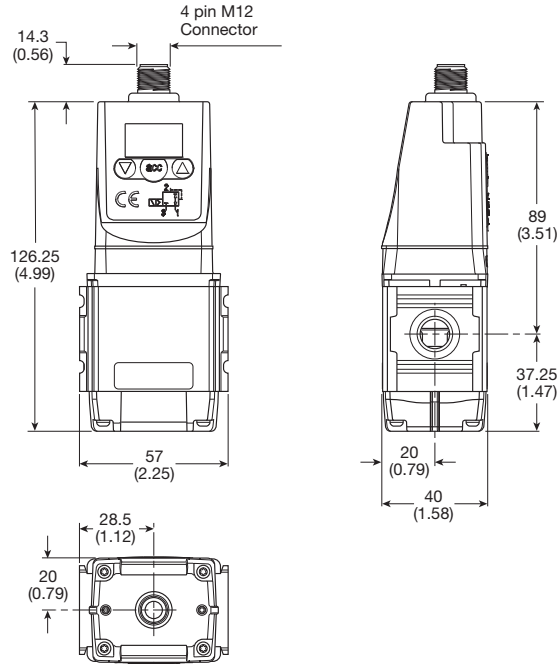

**L-Bracket
P3HKA00ML**

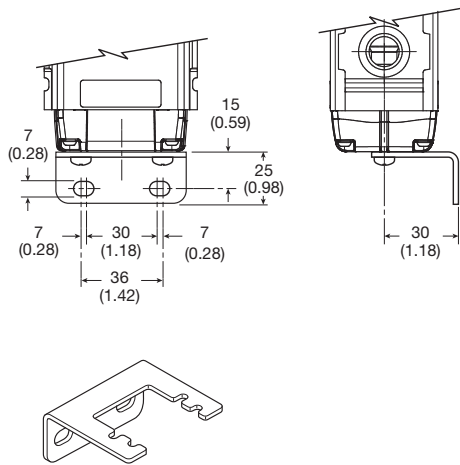

**Foot Bracket
P3HKA00MC**

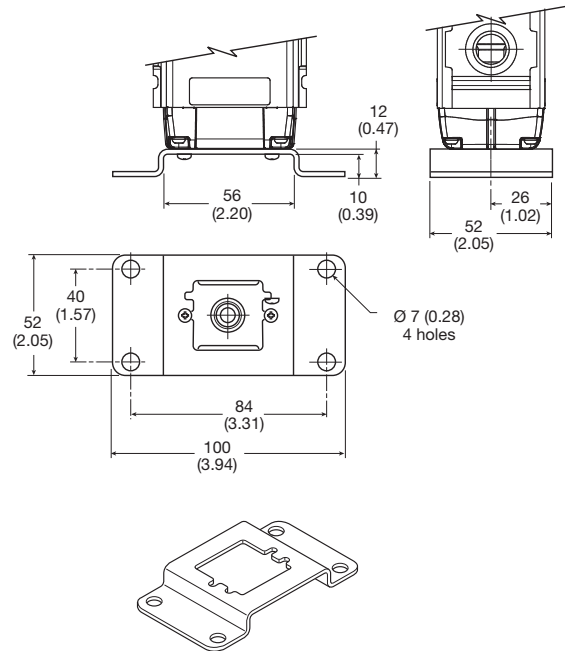

Cables

Description	Part Number
2 mtr. cable with moulded straight M12x1 connector	CB-M12-4P-2M

Most popular.



P32P

Dimensions inches (mm)

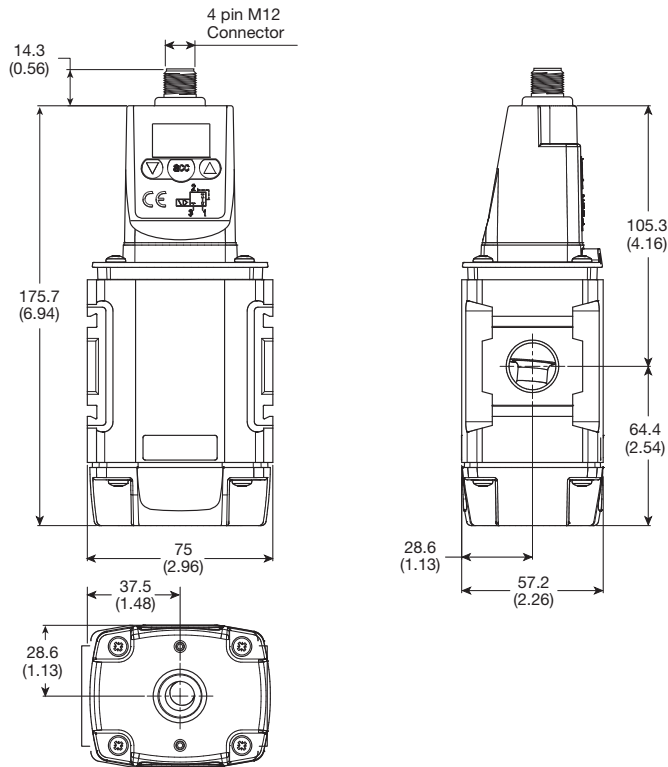

L-Bracket
P3KKA00ML

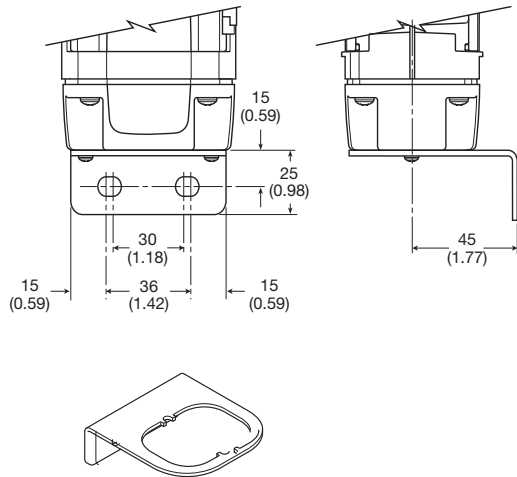

Foot Bracket
P3KKA00MC

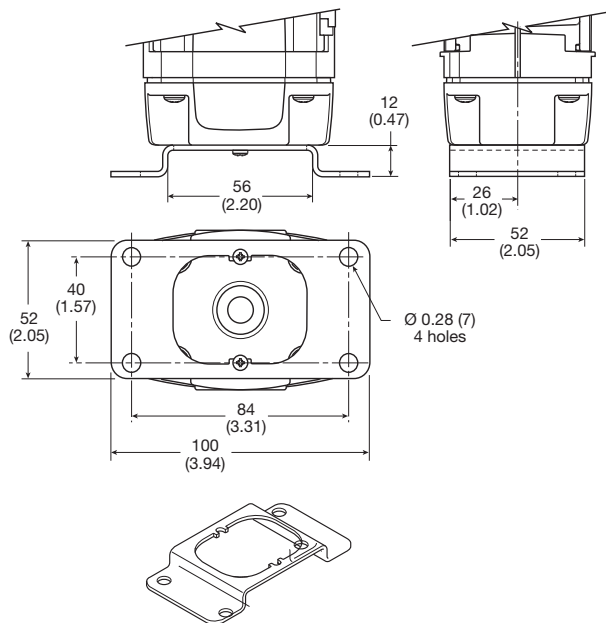

Cables

Description	Part Number
2 mtr. cable with moulded straight M12x1 connector	CB-M12-4P-2M

Most popular.



P31 Filter / Regulators – Mini

- Integral 1/4" ports (NPT, BSPP & BSPT)
- High efficiency 5 micron element as standard
- Excellent water removal efficiency
- Robust but lightweight aluminum construction
- Positive bayonet latch to ensure correct & safe fitting
- Secondary pressure ranges
- Secondary aspiration plus balanced poppet provides quick response and accurate pressure regulation

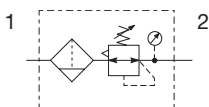

Port Size	Description (relieving)	Bowl / Drain Type †	Part Number
1/4"	125 psig (8 bar)	Poly / Manual	P31EB12EGMBN5P
1/4"	125 psig (8 bar)	Poly / Pulse	P31EB12EGBBN5P
1/4"	125 psig (8 bar)	Metal / Manual	P31EB12EMMBN5P
1/4"	125 psig (8 bar)	Metal / Pulse	P31EB12EMBBN5P

† For polycarbonate bowl, see caution in Engineering Section A.

Operating Information

Flow capacity*:	1/4	73 scfm (35 dm ³ /s, ANR)
Operating temperature†:	Plastic bowl	14°F to 125°F (-10°C to 52°C)
	Metal bowl	14°F to 150°F (-10°C to 65.5°C)
Supply pressure (max):	Plastic bowl	150 psig (10 bar)
	Metal bowl	250 psig (17 bar)
Standard filtration		5 micron
Useful retention†:		0.4 US oz. (12 cm ³)
Adjusting range pressure:		0 to 30 psig (0 to 2 bar)
		0 to 60 psig (0 to 4 bar)
		0 to 125 psig (0 to 8 bar)
		0 to 250 psig (0 to 17 bar)
Gauge port (2 each)**:		1/8 NPT, BSPP, BSPT
Weight:		0.42 lb (0.19 kg)
* Inlet pressure 145 psig (10 bar). Secondary pressure 91.3 psig (6.3 bar) and 14.5 psig (1 bar) pressure drop.		
** Non-gauge option only.		
† Units with square gauges: 5°F to 150°F (-15°C to 65.5°C)		
‡ Useful retention refers to volume below the quiet zone baffle.		

Air quality: Within ISO 8573-1: 2010 Class 6 (Particulates)

Ordering Information:

P31EB		1	2	E	G	M	B	N	T	P	
Basic Series	Global Modular Mini Filter / Regulator	Thread Type	BSPP 1 BSPT 2 NPT 9	Element	5µ Element E	Bowl Type	Poly Bowl with Bowl Guard G Metal Bowl without Sight Gauge M	Adjustment	Non-Rising Knob N	Mounting	Plastic Panel Mount Nut P
		Port Size	1/4 2			Drain Type	Pulse Drain B Manual Drain M Flex Drain X	Relief	Relieving B Non-Relieving N		
										Adjustment Range	
										With Square Gauge	With Round Gauge
										1 = 30* V = 2* 3 = 60 S = 4 5 = 125 T = 8	Z 30 psig; 2 bar; 0.2 MPa M 60 psig; 4 bar; 0.4 MPa G 125 psig; 8 bar; 0.8 MPa J [§] 232 psig; 16 bar; 1.6 MPa
											Without Gauge
											Y 30 psig; 2 bar; 0.2 MPa L 60 psig; 4 bar; 0.4 MPa N 125 psig; 8 bar; 0.8 MPa H [§] 232 psig; 16 bar; 1.6 MPa

* Regulator comes with gauge respective to the adjustment range selected.
§ Not available with poly bowl with bowl guard.

Options in grey boxes are not available or not stocked in EMEA region

Material Specifications

Body	Aluminum
Adjustment knob	Acetal
Body cap	ABS
Bonnet	PBT
Plastic bowl	Polycarbonate
Metal bowl	Aluminum
Bowl guard	Nylon
Filter element	Polyethylene
Seals	Nitrile
Springs	Steel
Valve assembly	Brass / Nitrile
Diaphragm assembly	Brass / Nitrile
Panel nut	Acetal

⚠ WARNING

**Product rupture can cause serious injury.
 Do not connect regulator to bottled gas.
 Do not exceed Maximum primary pressure rating.**

CAUTION:

REGULATOR PRESSURE ADJUSTMENT – The working range of knob adjustment is designed to permit outlet pressures within their full range. Pressure adjustment beyond this range is also possible because the knob is not a limiting device. This is a common characteristic of most industrial regulators, and limiting devices may be obtained only by special design. For best performance, regulated pressure should always be set by increasing the pressure up to the desired setting.

Flow Charts

P31EB 1/4" Filter / Regulator

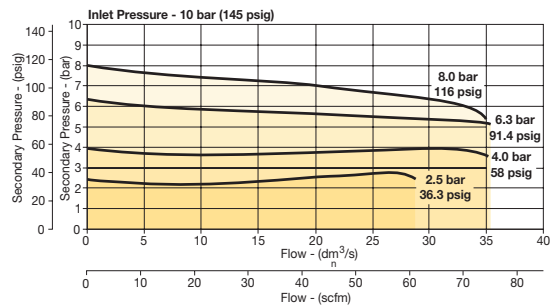

Repair and Service Kits

Plastic bowl / bowl guard manual drain	P31KB00BGM
Plastic bowl / bowl guard pulse drain	P31KB00BGB
Metal bowl / w/o sight gauge pulse drain	P31KB00BMB
5µ particle filter element	P31KA00ESE
Diaphragm repair kit - relieving	P31KB00RB
Diaphragm repair kit - non-relieving	P31KB00RC
Panel mount nut - aluminum	P31KA00MM
Panel mount nut - plastic	P31KA00MP
Angle bracket (attaches via panel nut)	P31KB00MR
C-bracket (fits to body)	P31KA00MW
T-bracket with body connector	P31KA00MT
Body connector	P31KA00CB

Gauges

Square flush mount gauge	0-4 bar	K4511SCR04B
	0-11 bar	K4511SCR11B
	0-60 psig	K4511SCR060
	0-160 psig	K4511SCR160
Square with adapter kit	0-4 bar	P6G-PR11040
	0-11 bar	P6G-PR11110
	0-60 psig	P6G-PR90060
	0-160 psig	P6G-PR90160
40mm Round 1/8" center back mount	0-60 psig / 0-4 bar	P3D-KAB1ALN
	0-160 psig / 0-11 bar	P3D-KAB1ANN
	0-300 psig / 0-20 bar	P3D-KAB1AHN

For best performance, regulated pressure should always be set by increasing the pressure up to the desired setting.

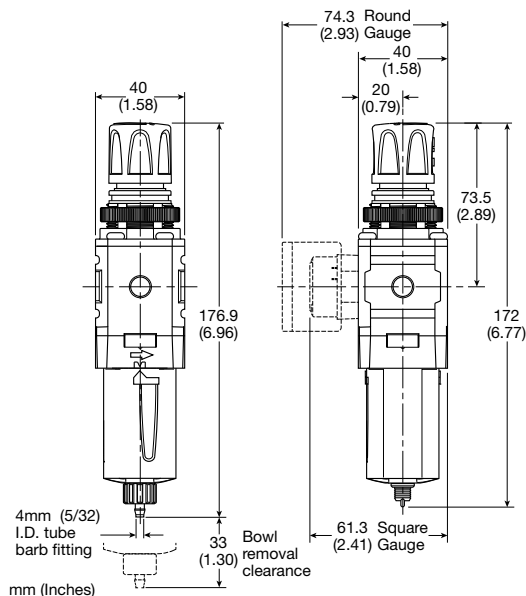

Manual Drain

Pulse Drain



P32 Filter / Regulators – Compact

- Integral 1/4", 3/8" or 1/2" ports (NPT, BSPP & BSPT)
- High efficiency 5 micron element as standard
- Excellent water removal efficiency
- Robust but lightweight aluminum construction
- Positive bayonet latch to ensure correct & safe fitting
- Secondary pressure ranges
- Secondary aspiration plus balanced poppet provides quick response and accurate pressure regulation

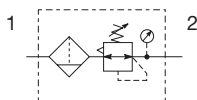

Port Size	Description (relieving)	Bowl / Drain Type †	Part Number
1/4"	125 psig (8 bar)	Poly / Manual	P32EB12EGMBNGP
1/4"	125 psig (8 bar)	Poly / Auto	P32EB12EGABNGP
1/4"	125 psig (8 bar)	Metal / Manual	P32EB12ESMBNGP
1/4"	125 psig (8 bar)	Metal / Auto	P32EB12ESABNGP
3/8"	125 psig (8 bar)	Poly / Manual	P32EB13EGMBNGP
3/8"	125 psig (8 bar)	Poly / Auto	P32EB13EGABNGP
3/8"	125 psig (8 bar)	Metal / Manual	P32EB13ESMBNGP
3/8"	125 psig (8 bar)	Metal / Auto	P32EB13ESABNGP
1/2"	125 psig (8 bar)	Poly / Manual	P32EB14EGMBNGP
1/2"	125 psig (8 bar)	Poly / Auto	P32EB14EGABNGP
1/2"	125 psig (8 bar)	Metal / Manual	P32EB14ESMBNGP
1/2"	125 psig (8 bar)	Metal / Auto	P32EB14ESABNGP

† For polycarbonate bowl, see caution in Engineering Section A.

Operating Information

Flow capacity*:	1/4	148 scfm (70 dm ³ /s, ANR)
	3/8	158 scfm (75 dm ³ /s, ANR)
	1/2	164 scfm (77 dm ³ /s, ANR)
Operating temperature:		
Plastic bowl		-13°F to 125°F (-25°C to 52°C)
Metal bowl		-13°F to 150°F (-25°C to 65.5°C)
Supply pressure (max):		
Plastic bowl		150 psig (10 bar)
Metal bowl		250 psig (17 bar)
Standard filtration:		5 micron
Useful retention†:		1.7 US oz. (51 cm ³)
Adjusting range pressure:		0 to 30 psig (0 to 2 bar)
		0 to 60 psig (0 to 4 bar)
		0 to 125 psig (0 to 8 bar)
		0 to 250 psig (0 to 17 bar)
Gauge port (2 each):		1/4 NPT, BSPP, BSPT
Weight:		1.17 lb (0.53 kg)

* Inlet pressure 145 psig (10 bar). Secondary pressure 91.3 psig (6.3 bar) and 14.5 psig (1 bar) pressure drop.

† Useful retention refers to volume below the quiet zone baffle.

Air quality: Within ISO 8573-1: 2010 Class 6 (Particulates)

Ordering Information:

Basic Series		Thread Type		Element		Adjustment		Mounting	
Global Modular Compact Filter / Regulator P32EB		BSPP 1	BSPT 2	5µ Element E		N Non-Rising Knob	T T-Handle	P Plastic Panel Mount Nut	
		NPT 9							
		Port Size							
		1/4	2						
		3/8	3						
		1/2	4						
		Bowl Type							
		Poly Bowl with Bowl Guard G							
		Metal Bowl without Sight Gauge M							
		Metal Bowl with Sight Gauge S							
		Drain Type							
		Manual Drain M							
		Auto Drain A							
		Flex Drain X							
				Relief					
				B Relieving					
				N Non-Relieving					
				Adjustment Range					
				With Square Gauge		With Round Gauge			
				psig	bar				
				1 = 30*	V = 2*	Z 30 psig; 2 bar; 0.2 MPa			
				3 = 60	S = 4	M 60 psig; 4 bar; 0.4 MPa			
				5 = 125	T = 8	G 125 psig; 8 bar; 0.8 MPa			
						J [§] 250 psig; 17 bar; 1.7 MPa			
						Without Gauge			
						Y 30 psig; 2 bar; 0.2 MPa			
						L 60 psig; 4 bar; 0.4 MPa			
						N 125 psig; 8 bar; 0.8 MPa			
						H [§] 250 psig; 17 bar; 1.7 MPa			

Options in grey boxes are not available or not stocked in EMEA region

* Regulator comes with gauge respective to the adjustment range selected.
[§] Not available with poly bowl with bowl guard.

Material Specifications

Body	Aluminum
Adjustment knob	Acetal
Element retainer / baffle	Acetal
Plastic bowl	Polycarbonate
Metal bowl	Aluminum
Bowl guard	Nylon
Filter element	Sintered polyethylene
Seals	Nitrile
Springs	Steel, stainless steel
Valve assembly	Brass / nitrile
Diaphragm assembly	Nitrile / zinc
Panel nut	Acetal
Sight gauge	Nylon

Repair and Service Kits

Plastic bowl / bowl guard manual drain	P32KB00BGM
Metal bowl / sight gauge manual drain	P32KB00BSM
Auto drain	P32KA00DA
5µ particle filter element	P32KA00ESE
Diaphragm repair kit - relieving	P32KB00RB
Diaphragm repair kit - non-relieving	P32KB00RC
Panel mount nut - aluminum	P32KA00MM
Panel mount nut - plastic	P32KA00MP
Angle bracket (fits to panel mount threads)	P32KB00MR
T-bracket (fits to body connector)	P32KA00MB
T-bracket with body connector	P32KA00MT
Body connector	P32KA00CB

Flow Charts

P32EB 1/4" Filter / Regulator

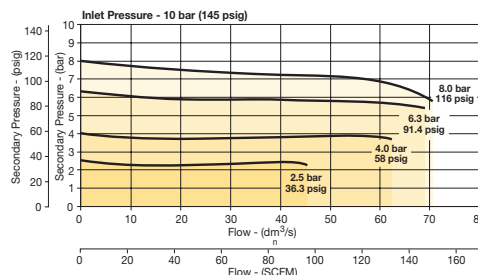

P32EB3/8" Filter/Regulator

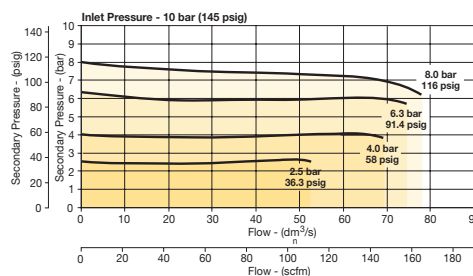

P32EB 1/2" Filter/Regulator

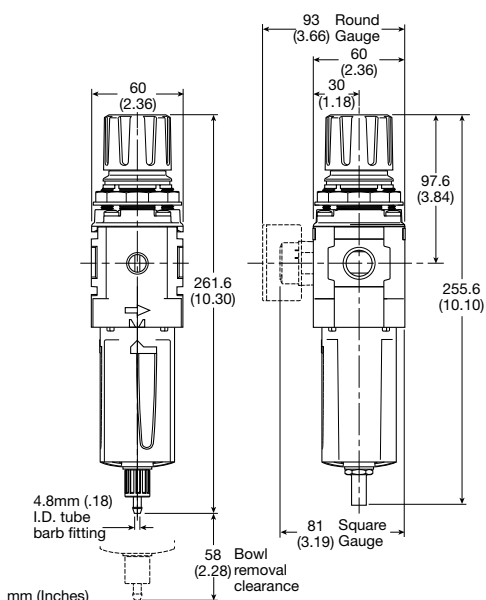
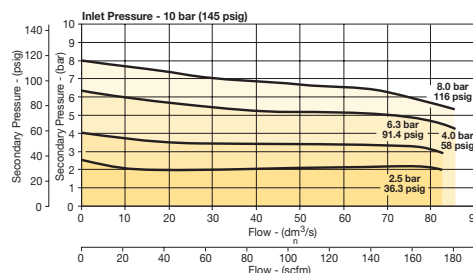

Manual Drain

Automatic Drain

WARNING

Product rupture can cause serious injury.
Do not connect regulator to bottled gas.
Do not exceed Maximum primary pressure rating.

CAUTION:

REGULATOR PRESSURE ADJUSTMENT – The working range of knob adjustment is designed to permit outlet pressures within their full range. Pressure adjustment beyond this range is also possible because the knob is not a limiting device. This is a common characteristic of most industrial regulators, and limiting devices may be obtained only by special design. For best performance, regulated pressure should always be set by increasing the pressure up to the desired setting.

Gauges

50mm (2") round	0-60 psig / 0-4 bar	P6G-ERB2040
1/4" center back mount	0-140 psig / 0-10 bar	P6G-ERB2110
	0-300 psig / 0-20 bar	P6G-ERB2200

For best performance, regulated pressure should always be set by increasing the pressure up to the desired setting.

P32 Semi-Precision Filter / Regulators – Compact

- Integral 1/4", 3/8" or 1/2" ports (NPT, BSPP & BSPT)
- High efficiency 5 micron element as standard
- Excellent water removal efficiency
- Robust but lightweight aluminum construction
- Positive bayonet latch to ensure correct & safe fitting
- Secondary pressure ranges
- Secondary aspiration plus balanced poppet provides quick response and accurate pressure regulation

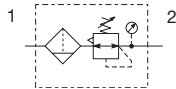

Port Size	Description / Relieving	Bowl / Drain Type †	Part Number
1/4"	125 psig (8 bar)	Poly / Manual	P32EB12EGMPNGP
1/4"	125 psig (8 bar)	Poly / Auto	P32EB12EGAPNGP
1/4"	125 psig (8 bar)	Metal / Manual	P32EB12ESMPNGP
1/4"	125 psig (8 bar)	Metal / Auto	P32EB12ESAPNGP
3/8"	125 psig (8 bar)	Poly / Manual	P32EB13EGMPNGP
3/8"	125 psig (8 bar)	Poly / Auto	P32EB13EGAPNGP
3/8"	125 psig (8 bar)	Metal / Manual	P32EB13ESMPNGP
3/8"	125 psig (8 bar)	Metal / Auto	P32EB13ESAPNGP
1/2"	125 psig (8 bar)	Poly / Manual	P32EB14EGMPNGP
1/2"	125 psig (8 bar)	Poly / Auto	P32EB14EGAPNGP
1/2"	125 psig (8 bar)	Metal / Manual	P32EB14ESMPNGP
1/2"	125 psig (8 bar)	Metal / Auto	P32EB14ESAPNGP

† For polycarbonate bowl, see caution in Engineering Section A.

Operating Information

Flow capacity*: 1/4, 3/8, 1/2	75 scfm (35 dm ³ /s, ANR)
Effect of supply pressure variation	0.6 psig (0.04 bar) for 25 psig (1.7 bar) change in P1
Operating temperature:	
Plastic bowl	-13°F to 125°F (-25°C to 52°C)
Metal bowl	-13°F to 150°F (-25°C to 65.5°C)
Supply pressure (max):	
Plastic bowl	150 psig (10 bar)
Metal bowl	250 psig (17 bar)
Standard filtration:	5 micron
Useful retention†:	1.7 US oz. (51 cm ³)
Adjusting range pressure:	0 to 30 psig (0 to 2 bar) 0 to 60 psig (0 to 4 bar) 0 to 125 psig (0 to 8 bar) 0 to 250 psig (0 to 17 bar)
Gauge port (2 each):	1/4 NPT, BSPP, BSPT
Weight:	1.17 lbs (0.53 kg)

* Inlet pressure 145 psig (10 bar). Secondary pressure 91.3 psig (6.3 bar) and 14.5 psig (1 bar) pressure drop.

† Useful retention refers to volume below the quiet zone baffle.

Air quality: Within ISO 8573-1: 2010 Class 6 (Particulates)

Ordering Information:

Basic Series		Thread Type		Element		Adjustment		Mounting	
Global Modular Compact Filter / Regulator P32EB		BSPP 1	BSPT 2	5µ Element E		N Non-Rising Knob	P Plastic Panel Mount Nut		
		NPT 9			T T-Handle				
Port Size		Bowl Type		Drain Type		Relief		Adjustment Range	
1/4 2	3/8 3	Poly Bowl with Bowl Guard G	Metal Bowl without Sight Gauge M	Manual Drain M	Auto Drain A	P Semi-Precision Relieving	With Square Gauge		With Round Gauge
1/2 4		Metal Bowl with Sight Gauge S				T Semi-Precision Non-Relieving	1 = 30* V = 2*	Z 30 psig; 2 bar; 0.2 MPa	M 60 psig; 4 bar; 0.4 MPa
								G 125 psig; 8 bar; 0.8 MPa	J [§] 250 psig; 17 bar; 1.7 MPa
								Without Gauge	
								Y 30 psig; 2 bar; 0.2 MPa	L 60 psig; 4 bar; 0.4 MPa
								N 125 psig; 8 bar; 0.8 MPa	H [§] 250 psig; 17 bar; 1.7 MPa

* Regulator comes with gauge respective to the adjustment range selected.
§ Not available with poly bowl with bowl guard.

Options in grey boxes are not available or not stocked in EMEA region

PDE2676TCUK
Global FRL and P3Y Series

P31, P32, P33 Series
Compact Semi-Precision Filter / Regulators

Material Specifications

Body	Aluminum
Adjustment knob	Acetal
Element retainer / baffle	Acetal
Plastic bowl	Polycarbonate
Metal bowl	Aluminum
Bowl guard	Nylon
Filter element	Sintered polyethylene
Seals	Nitrile
Springs	Steel, stainless steel
Valve assembly	Brass / nitrile
Diaphragm assembly	Nitrile / zinc
Panel nut	Acetal
Sight gauge	Nylon

Repair and Service Kits

Plastic bowl / bowl guard manual drain	P32KB00BGM
Metal bowl / sight gauge manual drain	P32KB00BSM
Auto drain	P32KA00DA
5µ particle filter element	P32KA00ESE
Diaphragm repair kit - relieving	P32KB00RB
Diaphragm repair kit - non-relieving	P32KB00RC
Panel mount nut - aluminum	P32KA00MM
Panel mount nut - plastic	P32KA00MP
Angle bracket (fits to panel mount threads)	P32KB00MR
T-bracket (fits to body connector)	P32KA00MB
T-bracket with body connector	P32KA00MT
Body connector	P32KA00CB

Flow Charts

P32EB 1/4" Filter / Regulator

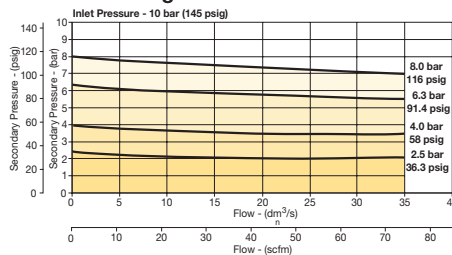

P32EB 3/8" Filter/Regulator

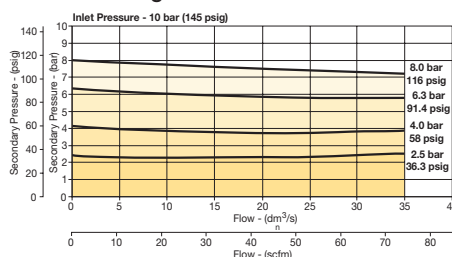

P32EB 1/2" Filter/Regulator

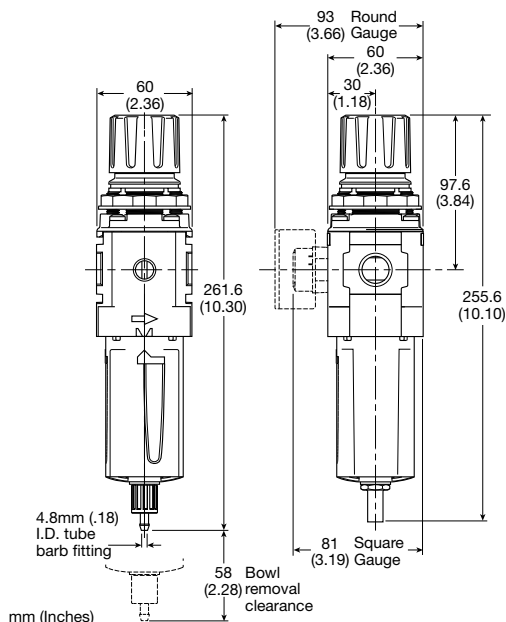
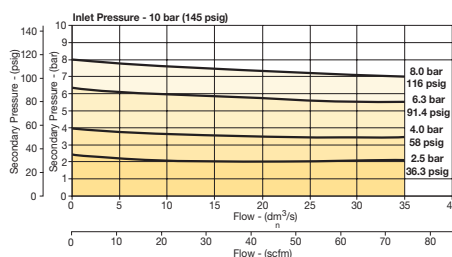

WARNING

Product rupture can cause serious injury. Do not connect regulator to bottled gas. Do not exceed Maximum primary pressure rating.

CAUTION:
REGULATOR PRESSURE ADJUSTMENT – The working range of knob adjustment is designed to permit outlet pressures within their full range. Pressure adjustment beyond this range is also possible because the knob is not a limiting device. This is a common characteristic of most industrial regulators, and limiting devices may be obtained only by special design. For best performance, regulated pressure should always be set by increasing the pressure up to the desired setting.

Gauges

50mm (2") round	0-60 psig / 0-4 bar	P6G-ERB2040
1/4" center back mount	0-160 psig / 0-11 bar	P6G-ERB2110
	0-300 psig / 0-20 bar	P6G-ERB2200

For best performance, regulated pressure should always be set by increasing the pressure up to the desired setting.



P33 Filter / Regulators – Standard

- Integral 1/2" or 3/4" ports (NPT, BSPP & BSPT)
- High efficiency 5 micron element as standard
- Excellent water removal efficiency
- Robust but lightweight aluminum construction
- Positive bayonet latch to ensure correct & safe fitting
- Secondary pressure ranges
- Secondary aspiration plus balanced poppet provides quick response and accurate pressure regulation

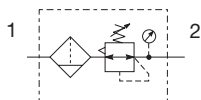

Port Size	Description / Relieving	Bowl / Drain Type †	Part Number
1/2"	125 psig (8 bar)	Poly / Manual	P33EA14EGMBNGP
1/2"	125 psig (8 bar)	Poly / Auto	P33EA14EGABNGP
1/2"	125 psig (8 bar)	Metal / Manual	P33EA14ESMBNGP
1/2"	125 psig (8 bar)	Metal / Auto	P33EA14ESABNGP
3/4"	125 psig (8 bar)	Poly / Manual	P33EA16EGMBNGP
3/4"	125 psig (8 bar)	Poly / Auto	P33EA16EGABNGP
3/4"	125 psig (8 bar)	Metal / Manual	P33EA16ESMBNGP
3/4"	125 psig (8 bar)	Metal / Auto	P33EA16ESABNGP

† For polycarbonate bowl, see caution in Engineering Section A.

Operating Information

Flow capacity*:	1/2	200 scfm (94 dm ³ /s, ANR)
	3/4	235 scfm (109 dm ³ /s, ANR)
Operating temperature:		
Plastic bowl		-13°F to 125°F (-25°C to 52°C)
Metal bowl		-13°F to 150°F (-25°C to 65.5°C)
Supply pressure (max):		
Plastic bowl		150 psig (10 bar)
Metal bowl		250 psig (17 bar)
Standard filtration:		5 micron
Useful retention†:		2.8 US oz. (85 cm ³)
Adjusting range pressure:		0 to 30 psig (0 to 2 bar)
		0 to 60 psig (0 to 4 bar)
		0 to 125 psig (0 to 8 bar)
		0 to 250 psig (0 to 17 bar)
Gauge port (2 each):		1/4 NPT, BSPP, BSPT
Weight:		1.87 lb. (0.85 kg)
* Inlet pressure 145 psig (10 bar). Secondary pressure 91.3 psig (6.3 bar) and 14.5 psig (1 bar) pressure drop.		
† Useful retention refers to volume below the quiet zone baffle.		

Air quality: Within ISO 8573-1: 2010 Class 6 (Particulates)

Ordering Information:

P33EA		1	6	E	G	M	B	N	G	P
Basic Series	Global Modular Standard Filter / Regulator	Thread Type	BSPP 1 BSPT 2 NPT 9	Element	5µ Element E	Adjustment	N Non-Rising Knob	Mounting	P Plastic Panel Mount Nut	
		Port Size	1/2 4 3/4 6	Bowl Type	Poly Bowl with Bowl Guard G Metal Bowl without Sight Gauge M Metal Bowl with Sight Gauge S	Relief	B Relieving N Non-Relieving	Adjustment Range		
						Drain Type	M Manual Drain A Auto Drain	With Round Gauge	Z 30 psig; 2 bar; 0.2 MPa M 60 psig; 4 bar; 0.4 MPa G 125 psig; 8 bar; 0.8 MPa J ^S 250 psig; 17 bar; 1.7 MPa	
								Without Gauge	Y 30 psig; 2 bar; 0.2 MPa L 60 psig; 4 bar; 0.4 MPa N 125 psig; 8 bar; 0.8 MPa H ^S 250 psig; 17 bar; 1.7 MPa	

Options in grey boxes are not available or not stocked in EMEA region

^S Not available with poly bowl with bowl guard.

Material Specifications

Body	Aluminum
Adjustment knob	Acetal
Body cap	ABS
Element retainer / baffle	Acetal
Plastic bowl	Polycarbonate
Metal bowl	Aluminum
Filter element	Sintered Polyethylene
Seals	Nitrile
Springs	Steel, stainless steel
Valve assembly	Brass / nitrile
Diaphragm assembly	Nitrile / zinc
Panel nut	Acetal
Sight gauge	Nylon

Repair and Service Kits

Plastic bowl / bowl guard, manual drain	P33KA00BGM
Metal bowl / sight gauge, manual drain	P33KA00BSM
Auto drain	P32KA00DA
5µ particle filter element	P33KA00ESE
Diaphragm repair kit - Relieving	P33KA00RB
Diaphragm repair kit - Non-relieving	P33KA00RC
Panel mount nut - Aluminum	P33KA00MM
Panel mount nut - Plastic	P33KA00MP
Angle bracket (fits to panel mount threads)	P33KA00MR
T-bracket (fits to body connector)	P32KA00MB
T-bracket with body connector	P32KA00MT
Body connector	P32KA00CB

Flow Charts

P33EA 1/2" Filter / Regulator

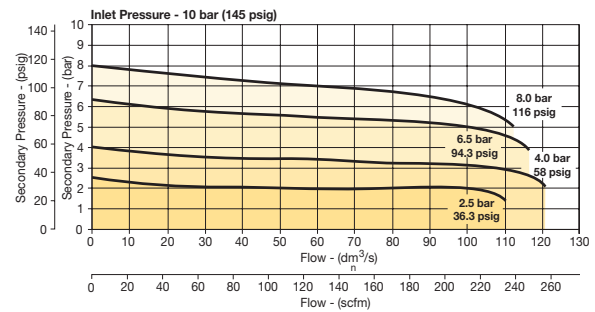

P33EA 3/4" Filter/Regulator

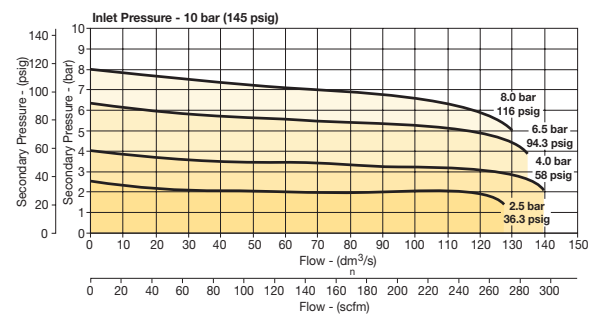

WARNING

Product rupture can cause serious injury.
Do not connect regulator to bottled gas.
Do not exceed Maximum primary pressure rating.

CAUTION:

REGULATOR PRESSURE ADJUSTMENT – The working range of knob adjustment is designed to permit outlet pressures within their full range. Pressure adjustment beyond this range is also possible because the knob is not a limiting device. This is a common characteristic of most industrial regulators, and limiting devices may be obtained only by special design. For best performance, regulated pressure should always be set by increasing the pressure up to the desired setting.

Gauges

50mm (2") round	0-60 psig / 0-4 bar	P6G-ERB2040
1/4" center back	0-160 psig / 0-11 bar	P6G-ERB2110
mount	0-300 psig / 0-20 bar	P6G-ERB2200

For best performance, regulated pressure should always be set by increasing the pressure up to the desired setting.

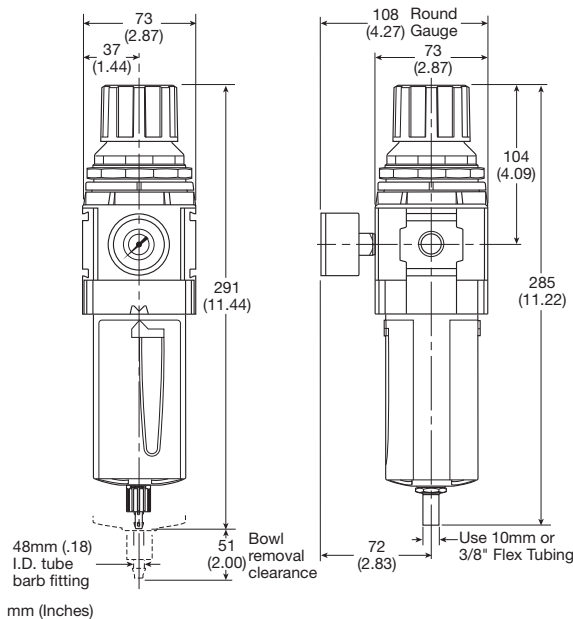

Manual Drain

Automatic Drain



P31 Lubricators – Mini

- Integral 1/4" ports (NPT, BSPP & BSPT)
- Robust but lightweight aluminum construction
- Proportional oil delivery over a wide range of air flows
- Finger tip ratchet control for precise oil drip rate adjustment

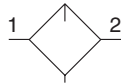

Lubricator with drain



Port Size	Description †	Part Number
1/4"	Poly Bowl - No Drain	P31LB12LGNN
1/4"	Metal Bowl - No Drain	P31LB12LMNN

† For polycarbonate bowl, see caution in Engineering Section A.

Operating Information

Flow capacity*:	
1/4	52 scfm (25 dm ³ /s, ANR)
Operating temperature:	
Plastic bowl	14°F to 125°F (-10°C to 52°C)
Metal bowl	14°F to 150°F (-10°C to 65.5°C)
Supply pressure (max):	
Plastic bowl	150 psig (10 bar)
Metal bowl	250 psig (17 bar)
Bowl capacity:	0.6 US oz. (18 cm ³)
Weight:	0.29 lb (0.13 kg)
* Inlet pressure 91.3 psig (6.3 bar). Pressure drop 4.9 psig (0.34 bar).	

Ordering Information:

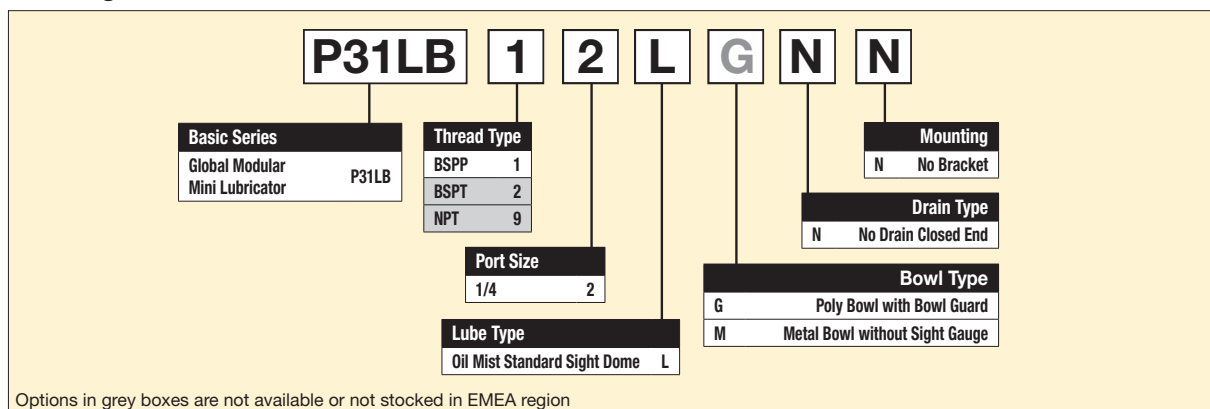

Suggested Lubricant
 Petroleum based oil of 100 to 200 SUS viscosity at 100°F (38°C) and an aniline point greater than 200°F (93°C)
 (DO NOT USE OILS WITH ADDITIVES, COMPOUNDED OILS CONTAINING SOLVENTS, GRAPHITE, DETERGENTS, OR SYNTHETIC OILS.)

PDE2676TCUK

Global FRL and P3Y Series

P31, P32, P33 Series Mini Lubricators

Material Specifications

Body	Aluminum
Body cap	ABS
Plastic bowl	Polycarbonate
Metal bowl	Aluminum
Seals	Nitrile
Sight dome	Polycarbonate
Suggested lubricant	ISO / ASTM VG32
Pick-up filter	Sintered bronze

Repair and Service Kits

Plastic bowl / bowl guard no drain	P31KB00BGN
Metal bowl / w/o sight gauge no drain	P31KB00BMN
Drip control assembly	P32KA00PG
Fill plug	P31KA00PL
C-bracket (fits to body)	P31KA00MW
T-bracket with body connector	P31KA00MT
Body connector	P31KA00CB
Lubricator oil - VG32 - 1 litre	P3YKA00PPBB

Flow Charts

P31LB 1/4" Lubricator

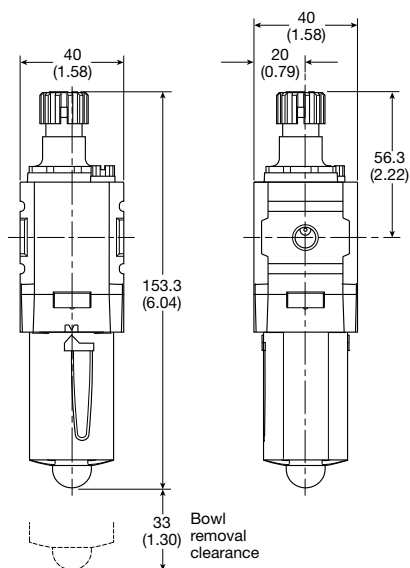
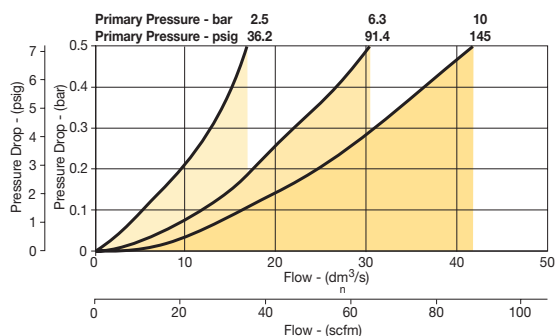

mm (Inches)

P32 Lubricators – Compact

- Integral 1/4", 3/8" or 1/2" ports (NPT, BSPP & BSPT)
- Robust but lightweight aluminum construction
- Proportional oil delivery over a wide range of air flows
- Finger tip ratchet control for precise oil drip rate adjustment
- Fill from top under system pressure

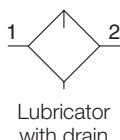

Port Size	Description †	Part Number
1/4"	Poly Bowl - No Drain	P32LB12LGNN
1/4"	Metal Bowl - No Drain	P32LB12LSNN
3/8"	Poly Bowl - No Drain	P32LB13LGNN
3/8"	Metal Bowl - No Drain	P32LB13LSNN
1/2"	Poly Bowl - No Drain	P32LB14LGNN
1/2"	Metal Bowl - No Drain	P32LB14LSNN

† For polycarbonate bowl, see caution in Engineering Section A.

Operating Information

Flow capacity*:	
1/4	38 scfm (17 dm ³ /s, ANR)
3/8	70 scfm (33 dm ³ /s, ANR)
1/2	90 scfm (42 dm ³ /s, ANR)
Operating temperature:	
Plastic bowl	14°F to 125°F (-10°C to 52°C)
Metal bowl	14°F to 150°F (-10°C to 65.5°C)
Supply pressure (max):	
Plastic bowl	150 psig (10 bar)
Metal bowl	250 psig (17 bar)
Bowl capacity:	4.09 US oz. (121 cm ³)
Weight:	0.68 lb (0.31 kg)
* Inlet pressure 91.3 psig (6.3 bar). Pressure drop 4.9 psig (0.34 bar).	

Ordering Information:

P32LB 1 3 L G N N

<div style="border: 1px solid black; padding: 5px; margin-bottom: 5px;">Basic Series</div> <div style="border: 1px solid black; padding: 5px; margin-bottom: 5px;">Global Modular Compact Lubricator</div> <div style="border: 1px solid black; padding: 5px; margin-bottom: 5px; text-align: right;">P32LB</div>	<div style="border: 1px solid black; padding: 5px; margin-bottom: 5px;">Thread Type</div> <table style="width: 100%; border-collapse: collapse;"> <tr><td style="border: 1px solid black; padding: 2px;">BSPP</td><td style="border: 1px solid black; padding: 2px;">1</td></tr> <tr><td style="border: 1px solid black; padding: 2px;">BSPT</td><td style="border: 1px solid black; padding: 2px;">2</td></tr> <tr><td style="border: 1px solid black; padding: 2px;">NPT</td><td style="border: 1px solid black; padding: 2px;">9</td></tr> </table>	BSPP	1	BSPT	2	NPT	9	<div style="border: 1px solid black; padding: 5px; margin-bottom: 5px;">Port Size</div> <table style="width: 100%; border-collapse: collapse;"> <tr><td style="border: 1px solid black; padding: 2px;">1/4</td><td style="border: 1px solid black; padding: 2px;">2</td></tr> <tr><td style="border: 1px solid black; padding: 2px;">3/8</td><td style="border: 1px solid black; padding: 2px;">3</td></tr> <tr><td style="border: 1px solid black; padding: 2px;">1/2</td><td style="border: 1px solid black; padding: 2px;">4</td></tr> </table>	1/4	2	3/8	3	1/2	4	<div style="border: 1px solid black; padding: 5px; margin-bottom: 5px;">Mounting</div> <div style="border: 1px solid black; padding: 5px; margin-bottom: 5px; text-align: center;">N No Bracket</div> <div style="border: 1px solid black; padding: 5px; margin-bottom: 5px;">Drain Type</div> <div style="border: 1px solid black; padding: 5px; margin-bottom: 5px; text-align: center;">N No Drain Closed End</div> <div style="border: 1px solid black; padding: 5px; margin-bottom: 5px;">Bowl Type</div> <table style="width: 100%; border-collapse: collapse;"> <tr><td style="border: 1px solid black; padding: 2px;">G</td><td style="border: 1px solid black; padding: 2px;">Poly Bowl with Bowl Guard</td></tr> <tr><td style="border: 1px solid black; padding: 2px;">S</td><td style="border: 1px solid black; padding: 2px;">Metal Bowl with Sight Gauge</td></tr> </table>	G	Poly Bowl with Bowl Guard	S	Metal Bowl with Sight Gauge
BSPP	1																		
BSPT	2																		
NPT	9																		
1/4	2																		
3/8	3																		
1/2	4																		
G	Poly Bowl with Bowl Guard																		
S	Metal Bowl with Sight Gauge																		
<div style="border: 1px solid black; padding: 5px; margin-bottom: 5px;">Lube Type</div> <div style="border: 1px solid black; padding: 5px; margin-bottom: 5px; text-align: center;">Oil Mist Standard Sight Dome L</div>																			

Options in grey boxes are not available or not stocked in EMEA region

Suggested Lubricant
 Petroleum based oil of 100 to 200 SUS viscosity at 100°F (38°C) and an aniline point greater than 200°F (93°C)
 (DO NOT USE OILS WITH ADDITIVES, COMPOUNDED OILS CONTAINING SOLVENTS, GRAPHITE, DETERGENTS, OR SYNTHETIC OILS.)

Material Specifications

Body	Aluminum
Body cap	ABS
Plastic bowl	Polycarbonate
Metal bowl	Aluminum
Seals	Nitrile
Sight dome	Polycarbonate
Sight gauge	Nylon
Suggested lubricant	ISO / ASTM VG32
Pick-up filter	Sintered bronze

Repair and Service Kits

Plastic bowl / bowl guard no drain	P32KB00BGN
Metal bowl / w/o sight gauge no drain	P32KB00BMN
Metal bowl / Sight gauge no drain	P32KB00BSN
Drip control assembly	P32KA00PG
Fill plug	P32KA00PL
L-bracket (fits to body)	P32KA00ML
T-bracket (fits to body connector)	P32KA00MB
T-bracket with body connector	P32KA00MT
Body connector	P32KA00CB
Lubricator oil - VG32 - 1 litre	P3YKA00PPBB

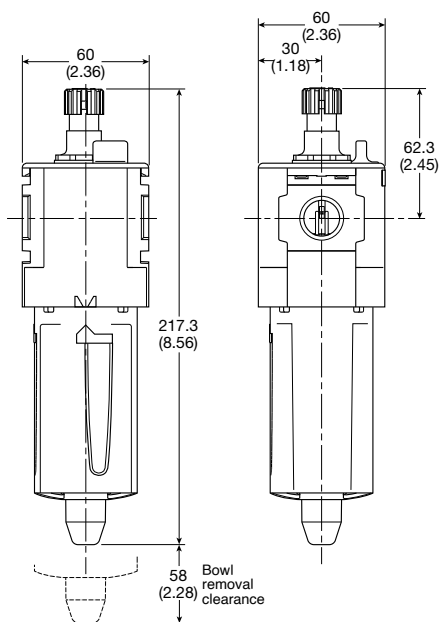

mm (Inches)

Flow Charts

P32LB 1/4" Lubricator

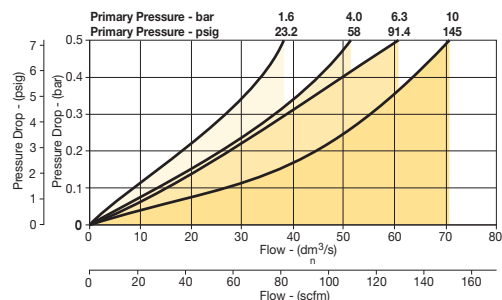

P32LB 3/8" Lubricator

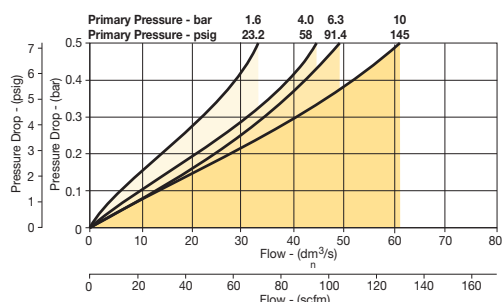

P32LB 1/2" Lubricator

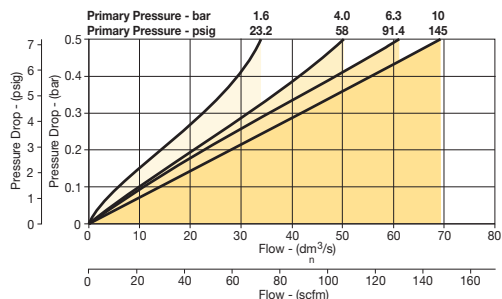

P33 Lubricators – Standard

- Integral 1/2" or 3/4" ports (NPT, BSPP & BSPT)
- Robust but lightweight aluminum construction
- Proportional oil delivery over a wide range of air flows
- Finger tip ratchet control for precise oil drip rate adjustment
- Fill from top under system pressure

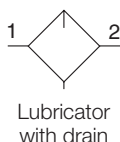

Port Size	Description †	Part Number
1/2"	Poly Bowl - No Drain	P33LA14LGNN
1/2"	Metal Bowl - No Drain	P33LA14LSNN
3/4"	Poly Bowl - No Drain	P33LA16LGNN
3/4"	Metal Bowl - No Drain	P33LA16LSNN

† For polycarbonate bowl, see caution in Engineering Section A.

Operating Information

Flow capacity*:	
1/2	110 scfm (52 dm ³ /s, ANR)
3/4	150 scfm (71 dm ³ /s, ANR)
Operating temperature:	
Plastic bowl	14°F to 125°F (-10°C to 52°C)
Metal bowl	14°F to 150°F (-10°C to 65.5°C)
Supply pressure (max):	
Plastic bowl	150 psig (10 bar)
Metal bowl	250 psig (17 bar)
Bowl capacity:	
	6.1 US oz. (181 cm ³)
Weight:	
	1.04 lb (0.47 kg)
* Inlet pressure 91.3 psig (6.3 bar). Pressure drop 4.9 psig (0.34 bar).	

Ordering Information:

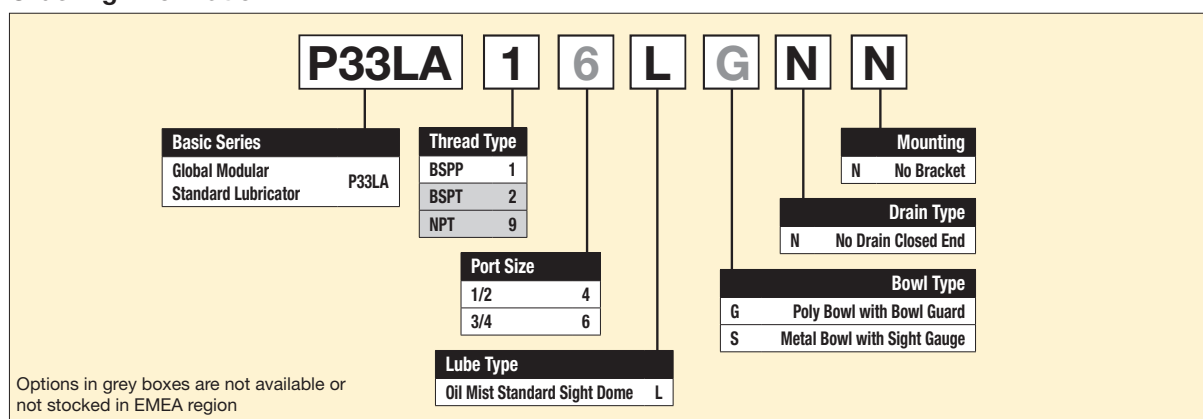

Suggested Lubricant
 Petroleum based oil of 100 to 200 SUS viscosity at 100°F (38°C) and an aniline point greater than 200°F (93°C)
 (DO NOT USE OILS WITH ADDITIVES, COMPOUNDED OILS CONTAINING SOLVENTS, GRAPHITE, DETERGENTS, OR SYNTHETIC OILS.)

Material Specifications

Body	Aluminum
Body cap	ABS
Plastic bowl	Polycarbonate
Metal bowl	Aluminum
Seals	Nitrile
Sight dome	Polycarbonate
Sight gauge	Nylon
Suggested lubricant	ISO / ASTM VG32
Pick-up filter	Sintered bronze

Repair and Service Kits

Plastic bowl / bowl guard no drain	P33KA00BGN
Metal bowl / w/o sight gauge no drain	P33KA00BMN
Metal bowl / sight gauge no drain	P33KA00BSN
Drip control assembly	P32KA00PG
Fill plug	P32KA00PL
L-bracket (fits to body)	P33KA00ML
T-bracket (fits to body connector)	P32KA00MB
T-bracket with body connector	P32KA00MT
Body connector	P32KA00CB
Lubricator oil - VG32 - 1 litre	P3YKA00PPBB

Flow Charts

P33LA 1/2" Lubricator

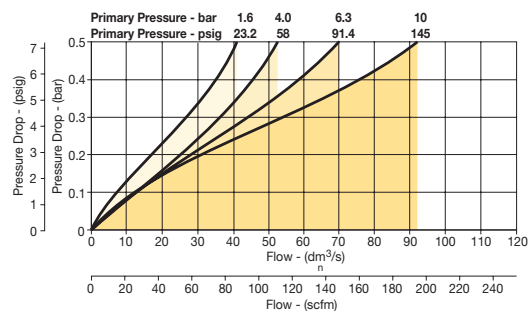

P33LA 3/4" Lubricator

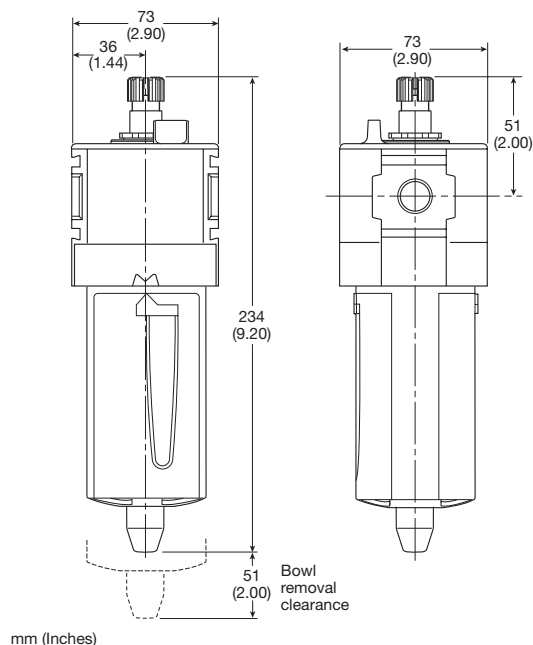
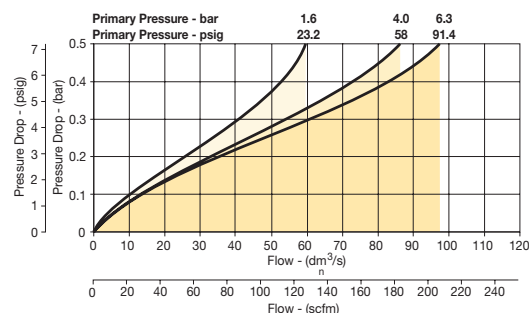

Popular Combinations: Inlet pressure 145 psig (10 bar), secondary pressure 91.3 psig (6.3 bar), 14.5 psig (1 bar) pressure drop.



Filter + Regulator + Lubricator Combinations, poly bowl
5 micron element, 116 psig (8 bar) regulator + gauge and wall mounting brackets



Port Size	Flow	Manual Drain	Pulse Drain
1/4"	27 scfm (13 dm ³ /s, ANR)	P31CB12GEMN5LNW	P31CB12GEBN5LNW



Filter/Regulator + Lubricator Combinations, poly bowl
5 micron element, 116 psig (8 bar) regulator + gauge and wall mounting brackets

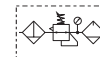

Port Size	Flow	Manual Drain	Pulse Drain
1/4"	28 scfm (14 dm ³ /s, ANR)	P31CA12GEMN5LNW	P31CA12GEBN5LNW



Ball Valve + Filter + Regulator + Lubricator Combinations, poly bowl
5 micron element, 116 psig (8 bar) regulator + gauge and wall mounting brackets

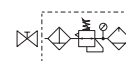

Port Size	Flow	Manual Drain	Pulse Drain
1/4"	27 scfm (13 dm ³ /s, ANR)	P31QB12GEMN5LNW	P31QB12GEBN5LNW



Ball Valve + Filter/Regulator + Lubricator Combinations, poly bowl
5 micron element, 116 psig (8 bar) regulator + gauge and wall mounting brackets

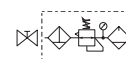

Port Size	Flow	Manual Drain	Pulse Drain
1/4"	28 scfm (14 dm ³ /s, ANR)	P31QA12GEMN5LNW	P31QA12GEBN5LNW

All combo are without any mounting nut on regulator or filter regulator.

Filter / Regulator coding
(use with codes: A M)

Filter coding (use with combo codes: B F G). For multiple filters, repeat as needed.	Regulator coding (use with combo code: B)	Lubricator coding (use with combo codes: A B)	Assembly configuration																																																																														
<p>P31</p> <p>Combination</p> <table border="1" style="width: 100%;"> <tr><td>B/V + Combination</td><td>Q</td></tr> <tr><td>Combination + B/V</td><td>X</td></tr> <tr><td>Combination</td><td>C</td></tr> </table> <p>B/V = Ball valve</p> <p>Combination Type*</p> <table border="1" style="width: 100%;"> <tr><td>F/R+L</td><td>A</td><td>F+Fc+Fa</td><td>G</td></tr> <tr><td>F+R+L</td><td>B</td><td>F/R+Fc</td><td>M</td></tr> <tr><td>F+Fc</td><td>F</td><td></td><td></td></tr> </table> <p>* Combination type F = 5µ Fc1 = 1µ Fc = .01µ Fa = Adsorber</p> <p>Bowl Type</p> <table border="1" style="width: 100%;"> <tr><td>Poly Bowl with Bowl Guard †</td><td>G</td></tr> <tr><td>Metal Bowl without Sight Gauge</td><td>M</td></tr> </table> <p>Note: All bowl types are the same for each component Example: If a "G" is specified for a F+L, both units would get a poly bowl with bowl guard. † For polycarbonate bowl, see caution in Engineering Section A.</p>	B/V + Combination	Q	Combination + B/V	X	Combination	C	F/R+L	A	F+Fc+Fa	G	F+R+L	B	F/R+Fc	M	F+Fc	F			Poly Bowl with Bowl Guard †	G	Metal Bowl without Sight Gauge	M	<p>Element</p> <table border="1" style="width: 100%;"> <tr><td>5µ Element</td><td>E</td></tr> <tr><td>0.01µ Element</td><td>C</td></tr> <tr><td>1µ Element</td><td>9</td></tr> <tr><td>Adsorber</td><td>A</td></tr> </table> <p>Drain Type</p> <table border="1" style="width: 100%;"> <tr><td>Manual Drain</td><td>M</td></tr> <tr><td>Pulse Drain</td><td>B</td></tr> </table>	5µ Element	E	0.01µ Element	C	1µ Element	9	Adsorber	A	Manual Drain	M	Pulse Drain	B	<p>Relief / Adjustment</p> <table border="1" style="width: 100%;"> <tr><td>Non-Rising Knob</td><td>N</td></tr> </table> <p>Adjustment Range</p> <table border="1" style="width: 100%;"> <tr><td>With Round Gauge</td><td></td></tr> <tr><td>30 psig; 2 bar; 0.2 MPa</td><td>Z</td></tr> <tr><td>60 psig; 4 bar; 0.4 MPa</td><td>M</td></tr> <tr><td>125 psig; 8 bar; 0.8 MPa</td><td>G</td></tr> <tr><td>232 psig; 16 bar; 1.6 MPa</td><td>J[§]</td></tr> <tr><td>Without Gauge</td><td></td></tr> <tr><td>30 psig; 2 bar; 0.2 MPa</td><td>Y</td></tr> <tr><td>60 psig; 4 bar; 0.4 MPa</td><td>L</td></tr> <tr><td>125 psig; 8 bar; 0.8 MPa</td><td>N</td></tr> <tr><td>232 psig; 16 bar; 1.6 MPa</td><td>H[§]</td></tr> </table> <p>With Square Gauge</p> <table border="1" style="width: 100%;"> <tr><td>psig</td><td>bar</td></tr> <tr><td>30* = 1</td><td>2* = V</td></tr> <tr><td>60 = 3</td><td>4 = S</td></tr> <tr><td>125 = 5</td><td>8 = T</td></tr> </table>	Non-Rising Knob	N	With Round Gauge		30 psig; 2 bar; 0.2 MPa	Z	60 psig; 4 bar; 0.4 MPa	M	125 psig; 8 bar; 0.8 MPa	G	232 psig; 16 bar; 1.6 MPa	J [§]	Without Gauge		30 psig; 2 bar; 0.2 MPa	Y	60 psig; 4 bar; 0.4 MPa	L	125 psig; 8 bar; 0.8 MPa	N	232 psig; 16 bar; 1.6 MPa	H [§]	psig	bar	30* = 1	2* = V	60 = 3	4 = S	125 = 5	8 = T	<p>Lub Type</p> <table border="1" style="width: 100%;"> <tr><td>Oil Mist</td><td>L</td></tr> <tr><td>Standard Sight Dome</td><td></td></tr> </table> <p>Drain Type</p> <table border="1" style="width: 100%;"> <tr><td>No Drain; Closed End</td><td>N</td></tr> </table> <p>Mounting</p> <table border="1" style="width: 100%;"> <tr><td>No Bracket</td><td>A</td></tr> <tr><td>Port Blocks</td><td>C[*]</td></tr> <tr><td>Port Blocks & Wall Brkt</td><td>D[*]</td></tr> <tr><td>Wall Bracket</td><td>W</td></tr> </table> <p>* For 3/8" Port Blocks please order separately. See Kits section.</p> <p>[§] Regulator comes with gauge respective to the adjustment range selected. [§] Not available with poly bowl with bowl guard.</p>	Oil Mist	L	Standard Sight Dome		No Drain; Closed End	N	No Bracket	A	Port Blocks	C [*]	Port Blocks & Wall Brkt	D [*]	Wall Bracket	W
B/V + Combination	Q																																																																																
Combination + B/V	X																																																																																
Combination	C																																																																																
F/R+L	A	F+Fc+Fa	G																																																																														
F+R+L	B	F/R+Fc	M																																																																														
F+Fc	F																																																																																
Poly Bowl with Bowl Guard †	G																																																																																
Metal Bowl without Sight Gauge	M																																																																																
5µ Element	E																																																																																
0.01µ Element	C																																																																																
1µ Element	9																																																																																
Adsorber	A																																																																																
Manual Drain	M																																																																																
Pulse Drain	B																																																																																
Non-Rising Knob	N																																																																																
With Round Gauge																																																																																	
30 psig; 2 bar; 0.2 MPa	Z																																																																																
60 psig; 4 bar; 0.4 MPa	M																																																																																
125 psig; 8 bar; 0.8 MPa	G																																																																																
232 psig; 16 bar; 1.6 MPa	J [§]																																																																																
Without Gauge																																																																																	
30 psig; 2 bar; 0.2 MPa	Y																																																																																
60 psig; 4 bar; 0.4 MPa	L																																																																																
125 psig; 8 bar; 0.8 MPa	N																																																																																
232 psig; 16 bar; 1.6 MPa	H [§]																																																																																
psig	bar																																																																																
30* = 1	2* = V																																																																																
60 = 3	4 = S																																																																																
125 = 5	8 = T																																																																																
Oil Mist	L																																																																																
Standard Sight Dome																																																																																	
No Drain; Closed End	N																																																																																
No Bracket	A																																																																																
Port Blocks	C [*]																																																																																
Port Blocks & Wall Brkt	D [*]																																																																																
Wall Bracket	W																																																																																

Options in grey boxes are not available or not stocked in EMEA region

Popular Combinations: Inlet pressure 145 psig (10 bar), secondary pressure 91.3 psig (6.3 bar), 14.5 psig (1 bar) pressure drop.



Filter + Regulator + Lubricator Combinations, poly bowl
5 micron element, 116 psig (8 bar) regulator + gauge and wall mounting brackets



Port Size	Flow	Manual Drain	Auto Drain
1/4"	42 scfm (20 dm ³ /s, ANR)	P32CB12GEMNGLNW	P32CB12GEANGLNW
3/8"	68 scfm (32 dm ³ /s, ANR)	P32CB13GEMNGLNW	P32CB13GEANGLNW
1/2"	85 scfm (40 dm ³ /s, ANR)	P32CB14GEMNGLNW	P32CB14GEANGLNW



Filter/Regulator + Lubricator Combinations, poly bowl
5 micron element, 116 psig (8 bar) regulator + gauge and wall mounting brackets



Port Size	Flow	Manual Drain	Auto Drain
1/4"	45 scfm (22 dm ³ /s, ANR)	P32CA12GEMNGLNW	P32CA12GEANGLNW
3/8"	70 scfm (33 dm ³ /s, ANR)	P32CA13GEMNGLNW	P32CA13GEANGLNW
1/2"	90 scfm (43 dm ³ /s, ANR)	P32CA14GEMNGLNW	P32CA14GEANGLNW



Ball Valve + Filter + Regulator + Lubricator Combinations, poly bowl
5 micron element, 116 psig (8 bar) regulator + gauge and wall mounting brackets

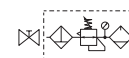

Port Size	Flow	Manual Drain	Auto Drain
3/8"	68 scfm (32 dm ³ /s, ANR)	P32QB13GEMNGLNW	P32QB13GEANGLNW
1/2"	85 scfm (40 dm ³ /s, ANR)	P32QB14GEMNGLNW	P32QB14GEANGLNW



Ball Valve + Filter/Regulator + Lubricator Combinations, poly bowl
5 micron element, 116 psig (8 bar) regulator + gauge and wall mounting brackets

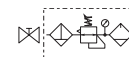

Port Size	Flow	Manual Drain	Auto Drain
3/8"	70 scfm (33 dm ³ /s, ANR)	P32QA13GEMNGLNW	P32QA13GEANGLNW
1/2"	90 scfm (43 dm ³ /s, ANR)	P32QA14GEMNGLNW	P32QA14GEANGLNW

All combo are without any mounting nut on regulator or filter regulator.

Filter / Regulator coding
(use with codes: A M)

Filter coding (use with combo codes: B F G). For multiple filters, repeat as needed.	Regulator coding (use with combo code: B)	Lubricator coding (use with combo codes: A B)	Assembly configuration																																																																														
<p>P32 C B 1 4 G</p> <p>Combination</p> <table border="1"> <tr><td>B/V + Combination</td><td>Q</td></tr> <tr><td>Combination + B/V</td><td>X</td></tr> <tr><td>Combination</td><td>C</td></tr> </table> <p>B/V = Ball valve</p> <p>Combination Type*</p> <table border="1"> <tr><td>F/R+L</td><td>A</td><td>F+Fc+Fa</td><td>G</td></tr> <tr><td>F+R+L</td><td>B</td><td>F/R+Fc</td><td>M</td></tr> <tr><td>F+Fc</td><td>F</td><td></td><td></td></tr> </table> <p>* Combination type F = 5µ Fc = 1µ Fc = .01µ Fa = Adsorber</p> <p>† For polycarbonate bowl, see caution in Engineering Section A.</p> <p>Bowl Type</p> <table border="1"> <tr><td>Poly Bowl with Bowl Guard †</td><td>G</td></tr> <tr><td>Metal Bowl without Sight Gauge</td><td>M*</td></tr> <tr><td>Metal Bowl With Sight Gauge</td><td>S</td></tr> </table> <p>* Not available when using lubricator. Note: All bowl types are the same for each component. Example: If a "G" is specified for a F+L, both units would get a poly bowl with bowl guard.</p>	B/V + Combination	Q	Combination + B/V	X	Combination	C	F/R+L	A	F+Fc+Fa	G	F+R+L	B	F/R+Fc	M	F+Fc	F			Poly Bowl with Bowl Guard †	G	Metal Bowl without Sight Gauge	M*	Metal Bowl With Sight Gauge	S	<p>Filter / Regulator coding (use with codes: A M)</p> <p>Filter coding (use with combo codes: B F G). For multiple filters, repeat as needed.</p> <p>Regulator coding (use with combo code: B)</p> <p>Relief / Adjustment</p> <p>Non-Rising Knob Relieving N</p> <p>Element</p> <table border="1"> <tr><td>0.01µ Element</td><td>C</td></tr> <tr><td>0.01µ Element with dpi</td><td>D*</td></tr> <tr><td>5µ Element</td><td>E</td></tr> <tr><td>5µ Element with dpi</td><td>F*</td></tr> <tr><td>1µ Element</td><td>9</td></tr> <tr><td>1µ Element with dpi</td><td>Q*</td></tr> <tr><td>Adsorber</td><td>A</td></tr> </table> <p>* Not available with F/R.</p> <p>Drain Type</p> <table border="1"> <tr><td>Auto Drain</td><td>A</td></tr> <tr><td>Manual Drain</td><td>M</td></tr> </table>	0.01µ Element	C	0.01µ Element with dpi	D*	5µ Element	E	5µ Element with dpi	F*	1µ Element	9	1µ Element with dpi	Q*	Adsorber	A	Auto Drain	A	Manual Drain	M	<p>Regulator coding (use with combo code: B)</p> <p>Adjustment Range</p> <table border="1"> <tr><td>30 psig; 2 bar; 0.2 MPa</td><td>Z</td></tr> <tr><td>60 psig; 4 bar; 0.4 MPa</td><td>M</td></tr> <tr><td>125 psig; 8 bar; 0.8 MPa</td><td>G</td></tr> <tr><td>250 psig; 17 bar; 1.7 MPa</td><td>J[§]</td></tr> </table> <p>Without Gauge</p> <table border="1"> <tr><td>30 psig; 2 bar; 0.2 MPa</td><td>Y</td></tr> <tr><td>60 psig; 4 bar; 0.4 MPa</td><td>L</td></tr> <tr><td>125 psig; 8 bar; 0.8 MPa</td><td>N</td></tr> <tr><td>250 psig; 17 bar; 1.7 MPa</td><td>H[§]</td></tr> </table> <p>With Square Gauge</p> <table border="1"> <tr> <td></td> <td>psig</td> <td>bar</td> </tr> <tr> <td>30* = 1</td> <td>2* = V</td> <td></td> </tr> <tr> <td>60 = 3</td> <td>4 = S</td> <td></td> </tr> <tr> <td>125 = 5</td> <td>8 = T</td> <td></td> </tr> </table> <p>* Regulator comes with gauge respective to the adjustment range selected. § Not available with poly bowl with bowl guard.</p>	30 psig; 2 bar; 0.2 MPa	Z	60 psig; 4 bar; 0.4 MPa	M	125 psig; 8 bar; 0.8 MPa	G	250 psig; 17 bar; 1.7 MPa	J[§]	30 psig; 2 bar; 0.2 MPa	Y	60 psig; 4 bar; 0.4 MPa	L	125 psig; 8 bar; 0.8 MPa	N	250 psig; 17 bar; 1.7 MPa	H[§]		psig	bar	30* = 1	2* = V		60 = 3	4 = S		125 = 5	8 = T		<p>Lubricator coding (use with combo codes: A B)</p> <p>Lub Type</p> <p>Oil Mist Standard Sight Dome L</p> <p>Drain Type</p> <p>No Drain; Closed End N</p> <p>Assembly configuration</p> <p>Mounting</p> <table border="1"> <tr><td>No Bracket</td><td>A</td></tr> <tr><td>Port Blocks</td><td>C</td></tr> <tr><td>Port Blocks & Wall Brkt</td><td>D</td></tr> <tr><td>Wall Bracket</td><td>W</td></tr> </table>	No Bracket	A	Port Blocks	C	Port Blocks & Wall Brkt	D	Wall Bracket	W
B/V + Combination	Q																																																																																
Combination + B/V	X																																																																																
Combination	C																																																																																
F/R+L	A	F+Fc+Fa	G																																																																														
F+R+L	B	F/R+Fc	M																																																																														
F+Fc	F																																																																																
Poly Bowl with Bowl Guard †	G																																																																																
Metal Bowl without Sight Gauge	M*																																																																																
Metal Bowl With Sight Gauge	S																																																																																
0.01µ Element	C																																																																																
0.01µ Element with dpi	D*																																																																																
5µ Element	E																																																																																
5µ Element with dpi	F*																																																																																
1µ Element	9																																																																																
1µ Element with dpi	Q*																																																																																
Adsorber	A																																																																																
Auto Drain	A																																																																																
Manual Drain	M																																																																																
30 psig; 2 bar; 0.2 MPa	Z																																																																																
60 psig; 4 bar; 0.4 MPa	M																																																																																
125 psig; 8 bar; 0.8 MPa	G																																																																																
250 psig; 17 bar; 1.7 MPa	J[§]																																																																																
30 psig; 2 bar; 0.2 MPa	Y																																																																																
60 psig; 4 bar; 0.4 MPa	L																																																																																
125 psig; 8 bar; 0.8 MPa	N																																																																																
250 psig; 17 bar; 1.7 MPa	H[§]																																																																																
	psig	bar																																																																															
30* = 1	2* = V																																																																																
60 = 3	4 = S																																																																																
125 = 5	8 = T																																																																																
No Bracket	A																																																																																
Port Blocks	C																																																																																
Port Blocks & Wall Brkt	D																																																																																
Wall Bracket	W																																																																																

Options in grey boxes are not available or not stocked in EMEA region



Popular Combinations: Inlet pressure 145 psig (10 bar), secondary pressure 91.3 psig (6.3 bar), 14.5 psig (1 bar) pressure drop.



Filter + Regulator + Lubricator Combinations, poly bowl
5 micron element, 116 psig (8 bar) regulator + gauge and wall mounting brackets



Port Size	Flow	Manual Drain	Auto Drain
1/2"	90 scfm (43 dm ³ /s, ANR)	P33CB14GEMNGLNW	P33CB14GEANGLNW
3/4"	110 scfm (52 dm ³ /s, ANR)	P33CB16GEMNGLNW	P33CB16GEANGLNW



Filter/Regulator + Lubricator Combinations, poly bowl
5 micron element, 116 psig (8 bar) regulator + gauge and wall mounting brackets



Port Size	Flow	Manual Drain	Auto Drain
1/2"	110 scfm (52 dm ³ /s, ANR)	P33CA14GEMNGLNW	P33CA14GEANGLNW
3/4"	150 scfm (71 dm ³ /s, ANR)	P33CA16GEMNGLNW	P33CA16GEANGLNW



Ball Valve + Filter + Regulator + Lubricator Combinations, poly bowl
5 micron element, 116 psig (8 bar) regulator + gauge and wall mounting brackets

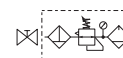

Port Size	Flow	Manual Drain	Auto Drain
1/2"	90 scfm (43 dm ³ /s, ANR)	P33QB14GEMNGLNW	P33QB14GEANGLNW
3/4"	110 scfm (52 dm ³ /s, ANR)	P33QB16GEMNGLNW	P33QB16GEANGLNW



Ball Valve + Filter/Regulator + Lubricator Combinations, poly bowl
5 micron element, 116 psig (8 bar) regulator + gauge and wall mounting brackets

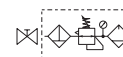

Port Size	Flow	Manual Drain	Auto Drain
1/2"	110 scfm (52 dm ³ /s, ANR)	P33QA14GEMNGLNW	P33QA14GEANGLNW
3/4"	150 scfm (71 dm ³ /s, ANR)	P33QA16GEMNGLNW	P33QA16GEANGLNW

All combo are without any mounting nut on regulator or filter regulator.

Filter / Regulator coding (use with codes: A M)		Filter coding (use with combo codes: B F G). For multiple filters, repeat as needed.	Regulator coding (use with combo code: B)	Lubricator coding (use with combo codes: A B)	Assembly configuration
P33	C B 1 6 G	E M	N G	L N	W
Combination B/V + Combination Q Combination + B/V X Combination C B/V = Ball valve Combination Type* F/R+L A F+Fc+Fa G F+R+L B F/R+Fc M F+Fc F * Combination type F = 5µ Fc = 1µ Fc = .01µ Fa = Adsorber Bowl Type † Poly Bowl With Bowl Guard G Metal Bowl Without Sight Gauge M* Metal Bowl With Sight Gauge S † For polycarbonate bowl, see caution in Engineering Section A. * Not available when using lubricator. Note: All bowl types are the same for each component. Example: If a "G" is specified for a F+L, both units would get a poly bowl with bowl guard.	Thread Type BSPP 1 BSPT 2 NPT 9 Port Size 1/2 4 3/4 6	Element 0.01µ Element C 0.01µ Element with dpi D* 5µ Element E 5µ Element with dpi F* 1µ Element 9 1µ Element with dpi Q* Adsorber A * Not available with F/R. Drain Type Auto Drain A Manual Drain M	Relief / Adjustment Non-Rising Knob Relieving N Adjustment Range With Round Gauge 30 psig; 2 bar; 0.2 MPa Z 60 psig; 4 bar; 0.4 MPa M 125 psig; 8 bar; 0.8 MPa G 250 psig; 17 bar; 1.7 MPa J* Without Gauge 30 psig; 2 bar; 0.2 MPa Y 60 psig; 4 bar; 0.4 MPa L 125 psig; 8 bar; 0.8 MPa N 250 psig; 17 bar; 1.7 MPa H* * Not available with poly bowl with bowl guard.	Lub Type Oil Mist Standard Sight Dome L Drain Type No Drain; Closed End N	Mounting No Bracket A Port Blocks C Port Blocks & Wall Brkt D Wall Bracket W

Options in grey boxes are not available or not stocked in EMEA region



Popular Combination Dimensions mm (inches)

P31C

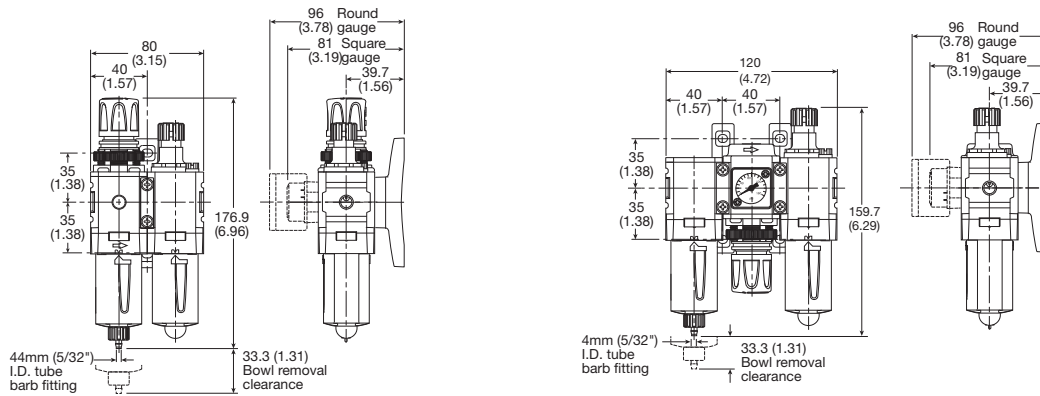

P32C

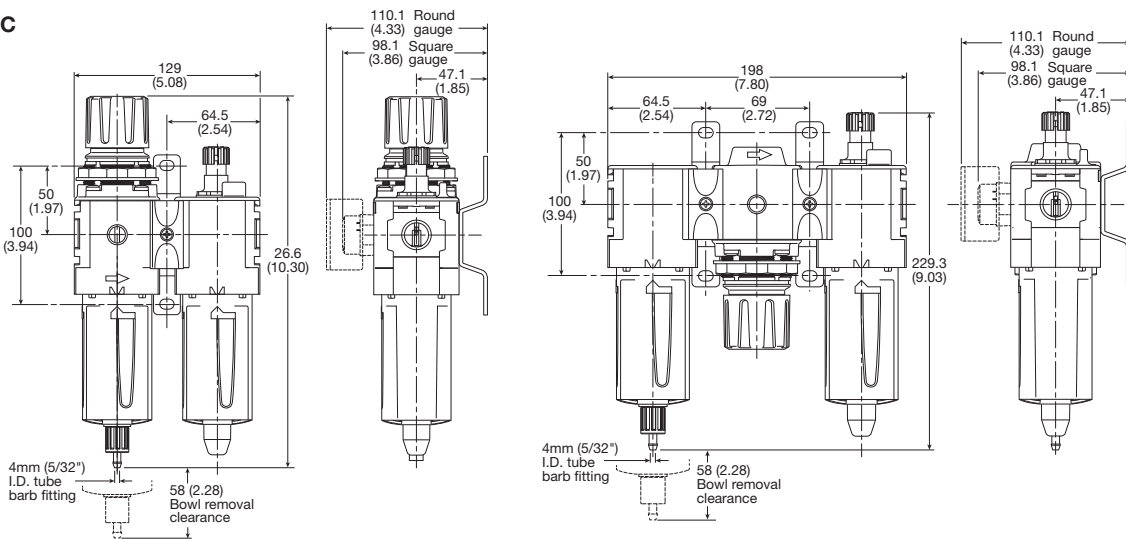

P33C

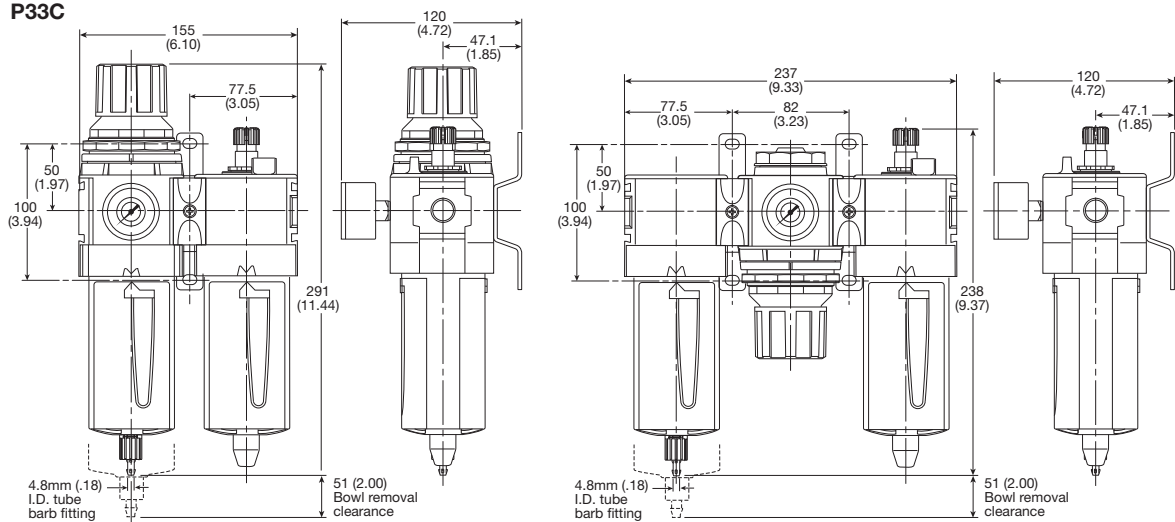

P31D & P32D Dump Valves

- Modular design with 1/4" or 1/2" integral ports (NPT, BSPP & BSPT)
- The 3-way, 2-position function automatically dumps downstream pressure on the loss of pilot signal
- Solenoid or air pilot options
- High flow & exhaust capability
- Silencer included

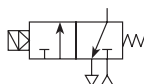

Remotely operated dump valves automatically shut off upstream pressure and exhaust the downstream pressure when the pilot pressure is released.

To maintain these units in the open position a pilot supply to the air pilot operated version or an electrical signal to the solenoid operated version must be maintained.

The valve will automatically dump when the holding signal is removed.



Port Size	Description	Weight lbs (kg)	Part Number
1/4"	120VAC Solenoid & cable plug	0.8 (0.37)	P31DA12SGNC1FN
1/4"	24VDC Solenoid & cable plug ‡	0.9 (0.41)	P31DA12SGNC2CN
1/4"	External air pilot operated	0.8 (0.37)	P31DA12PPN
1/2"	120VAC 30mm coil & cable plug incl. ‡	1.5 (0.69)	P32DA14SCNA3GN
1/2"	24VDC 30mm coil & cable plug incl. ‡	2.0 (0.91)	P32DA14SCNA2CN
1/2"	External air pilot operated ‡	1.9 (0.87)	P32DA14PPN

‡ Includes exhaust silencer

Operating Information

Flow capacity*:	P31D	36 scfm (17 dm ³ /s, ANR)
	P32D	108 scfm (51 dm ³ /s, ANR)
Temperature range (max)†:	Solenoid operated	14°F to 122°F (-10°C to 50°C)
	Air pilot operated	-4°F to 176°F (-20°C to 80°C)
Pressure (max):	Solenoid operated	150 psig (10 bar)
	Air pilot operated	250 psig (17 bar)
Operating pressure (min):		44 psig (3 bar)
Fluid:		Compressed air
Ports:	Air pilot	1/8
	Exhaust	P31D - 1/4; P32D - 1/2
	Gauge	P31D - 1/8; P32D - 1/4

* Inlet pressure 91.3 psig (6.3 bar), inlet pressure and 14.5 psig (1 bar) pressure drop.

† Air supply must be dry enough to avoid ice formation at temperatures below 35.6°F (2°C). Snap pressure: Full flow when downstream pressure reaches 50% of the inlet pressure.

Ordering Information:

Body Size		Thread Type		Pilot Type		Actuator Interface		Solenoid Voltage		Solenoid Type	
Dump Valve (1/4")	P31DA	BSPP	1	P	External Air Pilot	G	15mm Solenoid (P31 only)	2CN	24VDC Non Locking Manual Override	C	15mm (P31 series only)
Dump Valve (1/2")	P32DA	BSPT	2	S	Solenoid Pilot	C	30mm Solenoid	3GN	120VAC Non Locking Manual Override	A	30mm CNOMO Coil (P32 only)
		NPT	9			P	Threaded Air Pilot	1FN	120VAC Non Locking Manual Override (P31 series only)	D	30mm CNOMO Coil (M12 connection) (P32 only)



Note: P32 unit used for both P32 & P33 series

Options in grey boxes are not available or not stocked in EMEA region

Material Specifications

Body	Aluminum
Body cover	Polyester
Seals	Nitrile NBR

Mounting Brackets

	Description	Part number
	L-bracket mounting kit	P3HKA00ML
	Foot bracket mounting kit	P3HKA00MC

Flow Charts

P31DA 1/4" Remote Dump Valve

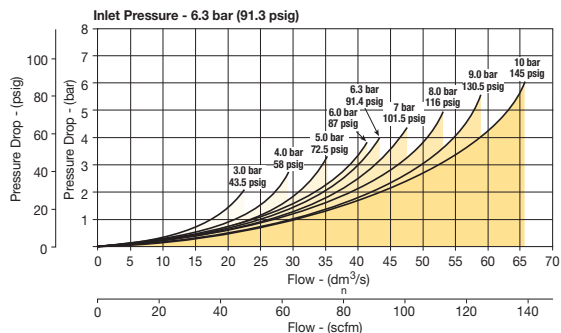

P32DA 1/2" Remote Dump Valve

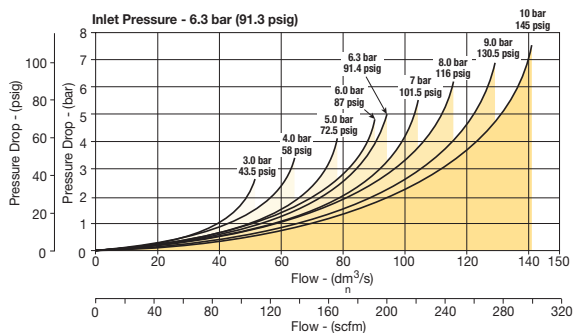

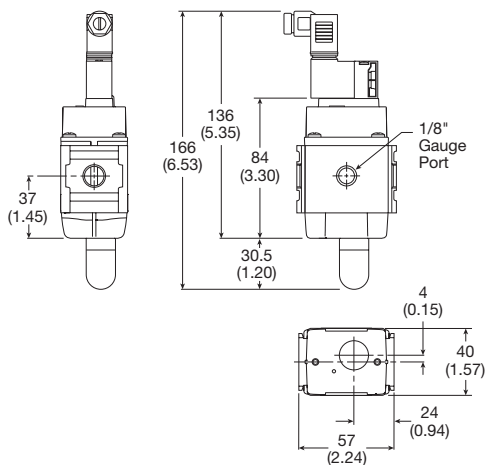

Dimensions mm (inches)

P31D

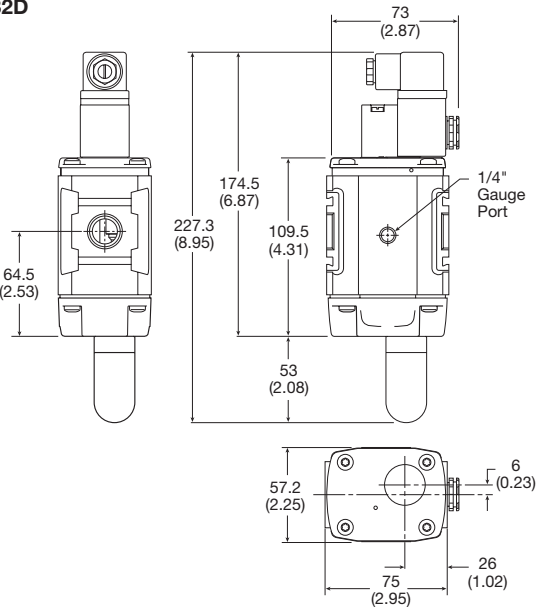

P32D



 Most popular.



P31S & P32S Soft Start Valves

- Modular design with 1/4" or 1/2" integral ports (NPT, BSPP & BSPT)
- The 2-way, 2-position function provides for the safe introduction of pressure
- Adjustable slow start
- Solenoid or air pilot options
- High flow

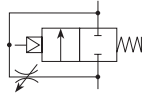

Parker Global Series Soft Start Valves, provide for the safe introduction of pressure to machines or systems. Soft Start Valves, allow the pressure to gradually build to the set point before fully opening to deliver full flow at line pressure.

The controlled introduction of pressure can be an important safety factor and prevent damage to tooling when air pressure is introduced at machine or system start up.

Note: Soft Start Valves must be installed downstream of a 3/2 valve with exhaust capability

Port Size	Description	Weight Lbs (Kg)	Part Number
1/4"	120VAC Solenoid & Cable Plug	0.8 (0.37)	P31SA12SGNC1FN
1/4"	24VDC Solenoid & Cable Plug	0.9 (0.41)	P31SA12SGNC2CN
1/4"	Internal Air Pilot Operated	0.8 (0.37)	P31SA12Y0N
1/4"	External Air Pilot (1/8" threaded)	0.8 (0.37)	P31SA12PPN
1/2"	120VAC 30mm Coil & Cable Plug incl.	1.5 (0.87)	P32SA14SCNA3GN
1/2"	24VDC 30mm Coil & Cable Plug	2.0 (0.90)	P32SA14SCNA2CN
1/2"	Internal Air Pilot Operated	2.0 (0.90)	P32SA14Y0N
1/2"	External Air Pilot (1/8" threaded)	1.5 (0.87)	P32SA14PPN

Operating Information

Flow capacity*:	P31S	36 scfm (17 dm ³ /s, ANR)
	P32S	101 scfm (48 dm ³ /s, ANR)
Temperature range (max)†:	Solenoid operated	14°F to 122°F (-10°C to 50°C)
	Air pilot operated	-4°F to 176°F (-20°C to 80°C)
Pressure (max):	Solenoid operated	150 psig (10 bar)
	Air pilot operated	250 psig (17 bar)
Operating pressure (min):		44 psig (3 bar)
Fluid:		Compressed air
Ports:	Air pilot	1/8"
	Gauge	P31S - 1/8"; P32S - 1/4"

* Inlet pressure 91.3 psig (6.3 bar), inlet pressure and 14.5 psig (1 bar) pressure drop.

† Air supply must be dry enough to avoid ice formation at temperatures below 35.6°F (2°C). Snap pressure: Full flow when downstream pressure reaches 50% of the inlet pressure.

Ordering Information:

P31SA **1** **2** **S** **G** **N**

Body Size	
Soft Start	P31SA
Soft Start	P32SA

Thread Type	
BSPP	1
BSPT	2
NPT	9

Port Size	
Global Modular Mini (1/4")	2
Global Modular Compact (1/2")	4

Actuator Interface	
O	Internal Pilot
G	15mm Solenoid (P31 Only)
C	30mm Solenoid
P	Threaded Air Pilot

Pilot Type	
P	External Air Pilot
S	Solenoid Pilot
Y	Internal Air Pilot

Solenoid type only

Solenoid Voltage	
2CN	24VDC Non Locking Manual Override
3GN	120VAC Non Locking Manual Override
1FN	120VAC Non Locking Manual Override (P31 series only)

Solenoid Type	
C	15mm (P31 series only)
A	30mm CNOMO Coil (P32 only)
D	30mm CNOMO Coil (M12 connection) (P32 only)

Note: P32 unit used for both P32 & P33 series

Options in grey boxes are not available or not stocked in EMEA region

PDE2676TCUK
Global FRL and P3Y Series

**P31, P32, P33 Series
 Soft Start Valves**

Material Specifications

Body	Aluminum
Body cover	Polyester
Seals	Nitrile NBR

Mounting Brackets

	Description	Part Number
P31	L-bracket mounting kit	P3HKA00ML
P31	Foot bracket mounting kit	P3HKA00MC

Flow Charts

P31SA 1/4" Soft Start Valve

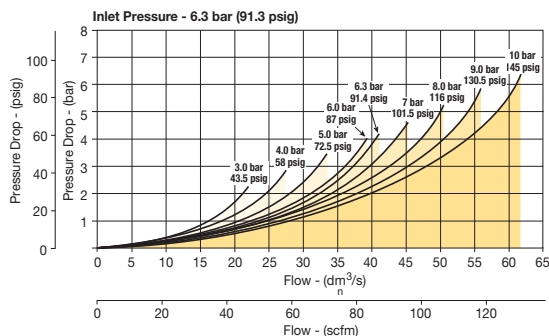

P32SA 1/2" Soft Start Valve

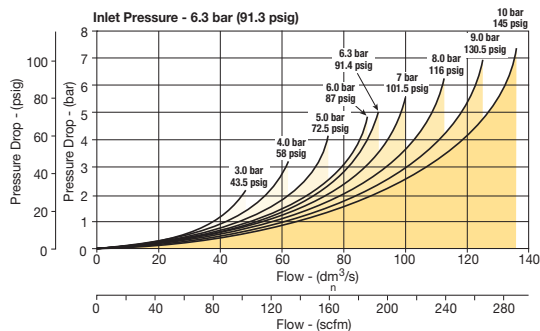

Dimensions mm (inches)

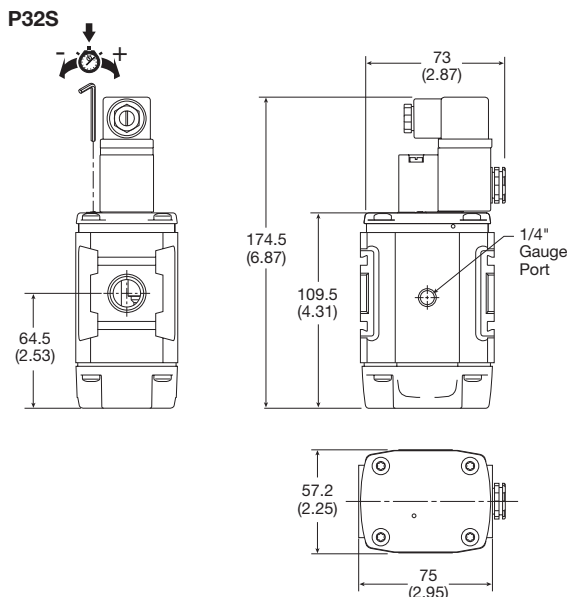
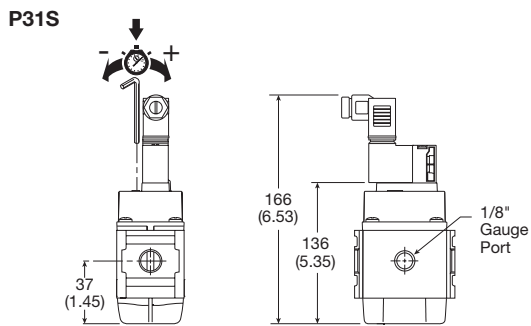

Soft Start Function:

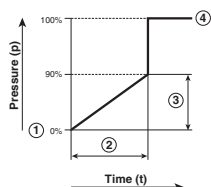

- ① Start signal
- ② Switching time delay
- ③ Gradual pressure build up
- ④ Operating pressure $p^2 (=p^*)$



P31T & P32T Combined Soft Start / Dump Valves

- Modular design with 1/4" or 1/2" integral ports (NPT, BSPP & BSPT)
- Provides for the safe introduction of pressure
- The 3-way, 2-position function automatically dumps downstream pressure on the loss of pilot signal
- Adjustable slow start
- Solenoid or air pilot options
- High flow & exhaust capability
- Silencer included

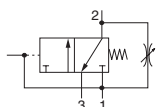

Parker Global Series Combined Soft Start / Dump Valves, provide for the safe introduction of pressure to machines or systems. Soft Start / Dump Valves when set, allow the pressure to gradually build to the set point before fully opening to deliver full flow at line pressure.

The controlled introduction of pressure can be an important safety factor and prevent damage to tooling when air pressure is introduced at machine or system start up.

To maintain these units in the open position a pilot supply to the air pilot operated version or an electrical signal to the solenoid operated version must be maintained. The valve will automatically dump when the holding signal is removed.

Port Size	Description	Weight lbs (kg)	Part Number
1/4"	120VAC Solenoid & cable plug	0.8 (0.37)	P31TA12SGNC1FN
1/4"	24VDC Solenoid & cable plug	0.9 (0.41)	P31TA12SGNC2CN
1/4"	External air pilot operated	0.8 (0.37)	P31TA12PPN
1/2"	120VAC 30mm coil & cable plug incl.	1.9 (0.87)	P32TA14SCNA3GN
1/2"	24VDC 30mm coil & cable plug incl.	2.0 (0.91)	P32TA14SCNA2CN
1/2"	External air pilot operated	1.9 (0.87)	P32TA14PPN

Operating Information

Flow capacity*:	P31T	36 scfm (17 dm ³ /s, ANR)
	P32T	97 scfm (46 dm ³ /s, ANR)
Temperature range (max)†:	Solenoid operated	14°F to 122°F (-10°C to 50°C)
	Air pilot operated	-4°F to 176°F (-20°C to 80°C)
Pressure (max):	Solenoid operated	150 psig (10 bar)
	Air pilot operated	250 psig (17 bar)
Operating pressure (min):		44 psig (3 bar)
Fluid:		Compressed air
Ports:	Air pilot	1/8
	Exhaust	P31T - 1/4; P32T - 1/2
	Gauge	P31T - 1/8; P32T - 1/4

* Inlet pressure 91.3 psig (6.3 bar), inlet pressure and 14.5 psig (1 bar) pressure drop.

† Air supply must be dry enough to avoid ice formation at temperatures below 35.6°F (2°C). Snap pressure: Full flow when downstream pressure reaches 50% of the inlet pressure.

Ordering Information:

P31TA

Body Size	Part Number
Soft Start / Dump Valve (1/4")	P31TA
Soft Start / Dump Valve (1/2")	P32TA

1

Thread Type	Code
BSPP	1
BSPT	2
NPT	9

2

Port Size	Code
Global Modular Mini (1/4")	2
Global Modular Compact (1/2")	4

S

Pilot Type	Code
External Air Pilot	P
Solenoid Pilot	S

G N

Actuator Interface	Code
15mm Solenoid (P31 only)	G
30mm Solenoid	C
Threaded Air Pilot	P

Solenoid type only

Actuator Interface	Solenoid Voltage
15mm Solenoid (P31 series only)	2CN 24VDC Non Locking Manual Override
30mm Solenoid	3GN 120VAC Non Locking Manual Override
30mm CNOMO Coil (M12 connection) (P32 only)	1FN 120VAC Non Locking Manual Override (P31 series only)

Solenoid Type	Code
15mm (P31 series only)	C
30mm CNOMO Coil (P32 only)	A
30mm CNOMO Coil (M12 connection) (P32 only)	D



Note: P32 unit used for both P32 & P33 series

Options in grey boxes are not available or not stocked in EMEA region

Material Specifications

Body	Aluminum
Body cover	Polyester
Seals	Nitrile NBR

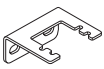
Mounting Brackets

	Description	Part Number
		P31D
	L-bracket mounting kit	P3HKA00ML
	Foot bracket mounting kit	P3HKA00MC

Flow Charts

P31TA 1/4" Soft Start & Dump Valve

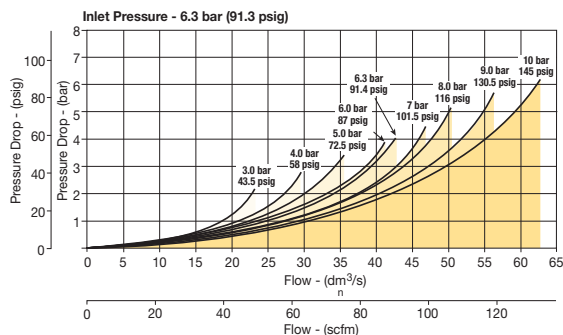

P32TA 1/2" Soft Start & Dump Valve

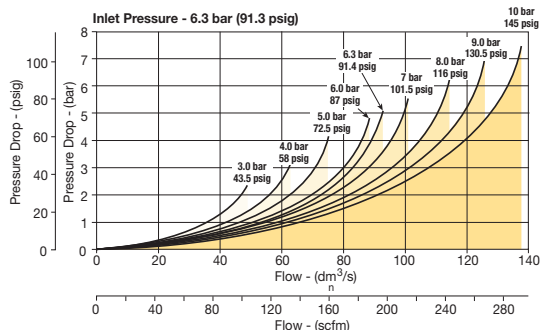

Dimensions mm (inches)

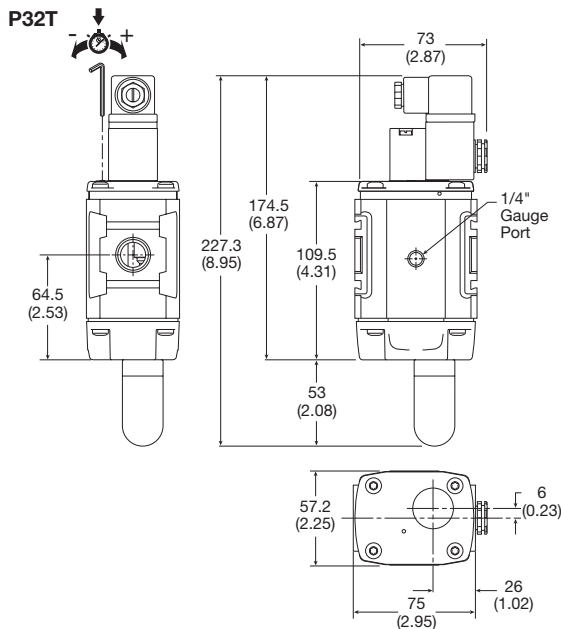
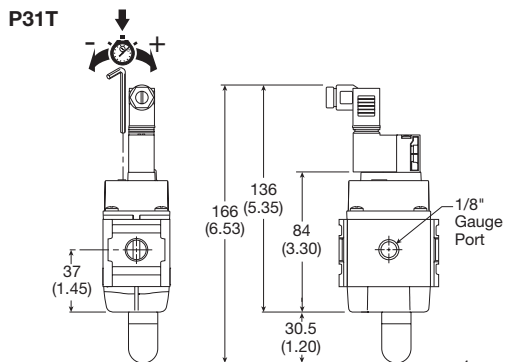

Soft Start Function:

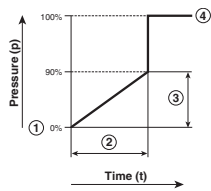

- ① Start signal
- ② Switching time delay
- ③ Gradual pressure build up
- ④ Operating pressure $p^2 (=p^1)$

P33D & P33T Safety Exhaust Valves

- Easy electrical interface with M12 connectors to safety circuit
- External monitoring provides a cost and space saving advantage
- Solid state pressure sensors provide accurate, fast fault detection
- Quick visual LED indicators on the front of the valve
- Superior seated seal design for longer life
- Safety exhaust outlet is no-maintenance and non-clog by design
- Suitable for stand alone use or modular mounting to P32 or P33 FRL assembly
- High B10 life value
- Fast exhaust times allow for smaller machine footprint

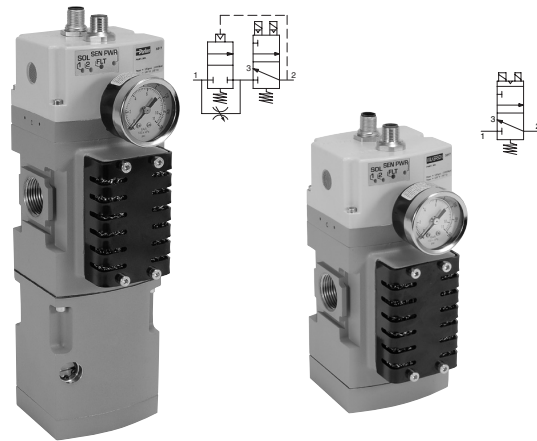

(optional soft start)

Operating Information

Operating pressure:	30 to 150 PSIG (2 to 10 bar)
Minimum operating pressure:	30 PSIG (2 bar)
Ambient temperature:	40° to 120°F (4° to 50°C)
Recommended filtration:	40µ
Operating medium:	Compressed air
Ingress protection class:	IP65
B10 (mio):	10 million switching cycles
B10 d (mio):	20 million switching cycles
Allowable discordance:	150ms
Flow media:	Compresses air to ISO 8573-1 Class 7:4:4
Weight lbs (kg):	6.5 (2.9) with soft start 4.2 (1.9) without soft start

The soft start opens to full flow at approximately 60% of input pressure.

Note:

P33*B16AAEN as general use for relay
P33*B16ABEN uses with Rockwell
P33*B16CAEN uses with Siemens
P33*B16CCEN uses with Siemens
P33*B16DCEN uses with Rockwell & Turck

Ordering Information:

P3	3	T	B	1	6	A	B	E	N
Series	Global		Design		Port Size			Sensor Monitoring	Gauge²
Standard P3	Standard 3		Current B		3/4" ¹ 6			External E	No Gauge N
		Type		Thread Type		Output for Solenoid, M12 Connector Pin			Dial Gauge ³ (standard) G
		Safety Redundant (no soft start) D		BSPP 1		2 & 4, Common 3 A			Digital Gauge ³ D
		Safety Redundant (c/w soft start) T		NPT 9		3 & 4 C	Output for Sensors, M12 Connector Pin		MPS-P34 Pressure Sensor M
						2 & 4 D	1 & 2, 1 & 4, Common 3 A		
							1 & 2, 5 & 4, Common 3 B		
							5 & 2, 1 & 4, Common 3 C		

Notes:

1. For 1/2" connections use 1/2" port blocks on standard 3/4" housing.
2. Safety valve supplied with 1/8" gauge port in either BSPP or NPT threads as specified for ports.
3. Dial or digital gauge not available on BSPP version.

Options in grey boxes are not available or not stocked in EMEA region

PDE2676TCUK

Global FRL and P3Y Series

**P31, P32, P33 Series
Safety Exhaust Valves**

General Technical Data

Valve type	Externally monitored, redundant, dual poppet
Soft start	Optional
Valve function	3/2 way, normally closed
Housing material	Cast aluminum
Seals	NBR
Fasteners	Stainless steel / brass
Silencer	Steel, non clog safety design

Electrical Specifications

Operating voltage	24V DC
Electrical connection	Two M12 connectors
Switching time 1-2 (ms)	23.3
Switching time 2-3 (ms)	42.7
Duty cycle (%)	100%
Operating voltage (DC)	21.6 to 26.4
Nominal power	
per solenoid coil at 24V DC (W) +/- 10%	1.2 W
per pressure sensor at 24V DC	1.2 W

In accordance with EN ISO 13849-1 this safety valve is suitable for use up to Category 4, Pl e, sil 3. Certified to cCSA_{US} and bears the CE mark.

A product Integration Guide is available to help connect your logic controller to the Parker Safety Exhaust Valve under the Product Support tab at www.parker.com/pdn/safetyvalve

Mounting Hardware

Body Connector		P32KA00CB
T-Bracket w / Body Connector		P32KA00MT
T-Bracket (fits to body connector or port block)		P32KA00MB
Port Block Kits (includes two)	1/2" NPT	P32KA94CP
	1/2" BSPT	P32KA24CP
	1/2" BSPP	P32KA14CP
	3/4" NPT	P32KA96CP
	3/4" BSPT	P32KA26CP
	3/4" BSPP	P32KA16CP

Solenoid M12 Pinouts

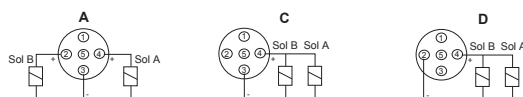

Pressure Sensor M12 Pinouts

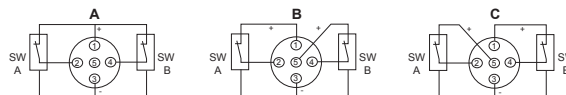

Externally Monitored (with Soft Start)

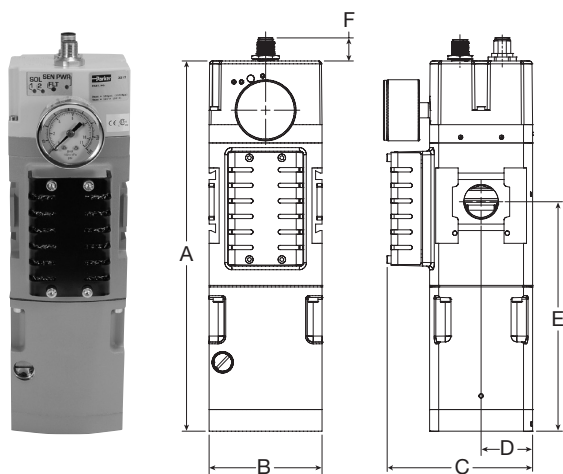

Externally Monitored (No Soft Start)

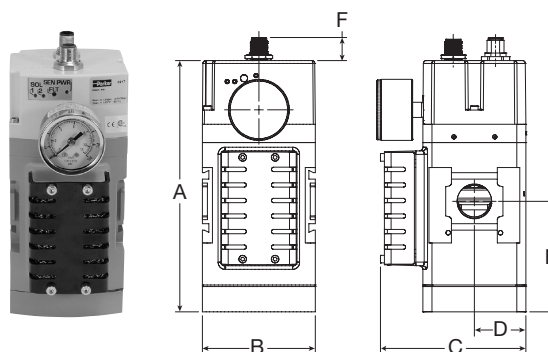

Dimensions inches (mm)

	Ports	Standard nominal flow rate		A	B	C	D	E	F
		1 → 2 L/min (SCFM)*	2 → 3 L/min (SCFM)*						
Externally Monitored with soft start	3/4"	4,100 (145)	7,500 (265)	10.31 (261.9)	3.15 (80)	4.30 (109.3)	1.44 (36.5)	6.39 (162.3)	0.64 (16.3)
Externally Monitored no soft start	3/4"	4,300 (152)	7,500 (265)	7.03 (178.7)	3.15 (80)	4.30 (109.3)	1.44 (36.5)	3.11 (79.0)	0.64 (16.3)

* Standard nominal flow rate is based on 6 bar input pressure with ΔP = 1 bar



Safety Exhaust Valve Function

When applications demand a safe environment you can count on safety valves from Parker Hannifin. The P33 family of safety exhaust valves are 3/2 normally closed valves designed to rapidly exhaust compressed air in the event of a fault condition and to provided monitored coverage ensuring safe function. The P33 is available in two distinct styles, internally* or externally monitored. The valve is suitable for use up to Category 4, performance level e. Monitoring is achieved externally via a two channel system connected to a safety interface device. Both valves are available with an adjustable soft start and high flow exhaust to shut your equipment down faster when needed. LED's provide clear status of main solenoid operation, sensor power and fault condition for quick visual reference.

Externally Monitored Valve, Faults and Resets

The externally monitored valve has the monitoring done via a PLC or relay which offers a size and cost advantage over internally monitored valves. The integration of a safety interface into the PLC or relay will help determined the achievable category and performance level of the control system. Customers are required to provide the logic function via the safety device. The valve will lock-out to the "safe state" if asynchronous movement of the valve elements occur which will be detected by solid state pressure sensors. To achieve the proper safety rating, the safety PLC or relay must monitor the solid state pressure sensors to ensure they are not in different states for more than 150ms. If the sensors are in different states for longer than 150ms then the programming logic must shut off power to the solenoids and consider it a fault condition. If during operation the externally monitored P33 enters a fault condition the valve will shut off. A separate reset signal must be incorporated into the logic sequence to avoid automatic restart of the valve. The safety exhaust valves are not for use with clutch or brake applications and are designed for use in conjunction with a safety relay or safety PLC for safe monitoring and fault detection.

Achieving Desired Performance Level **

The category and performance level (PLr) needed for your machine is determined by a risk assessment of the machinery design and application based on EN ISO 13849-1. The Parker P33 safety valve is designed for those applications requiring a PL of d or e. Please note these levels require other aspects of the system to meet these requirements. As a guide: you can achieve a Cat 4 PL e system by integrating monitoring via a programmable safety rated device. Because the P33 is a mechanical fail-safe device, the monitoring could also be done via a standard PLC and still attain as high as a PL d rating.

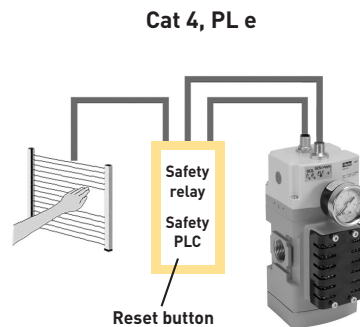
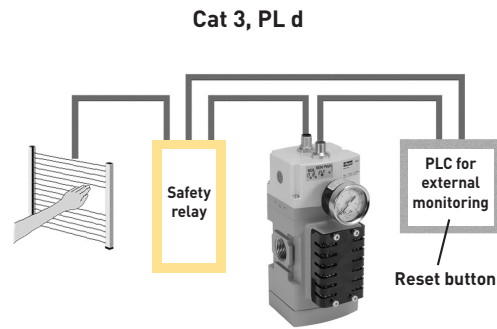

* For information on internally monitored safety valves reference Bulletin 0700-B13.

** An integration guide is available to provide further information on connecting the safety valve product to achieve the desired performance level. Please consult Parker and the standard EN ISO 13849-1 for more information.

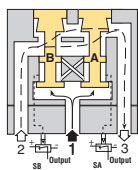

Conditions at Start

The Safety exhaust valve starts with inlet 1 closed to outlet 2 by both valve elements A and B. Outlet 2 is open to exhaust 3. Pressure signals at both sensors SA and SB are exhausted and contacts 1 and 2 of sensors SA and SB are connected. The normally closed sensors both provide voltage feedback signals to the external monitoring system.

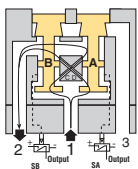

Normal Operation

During normal operation the two solenoids are simultaneously energized which actuates both pilots and causes valve elements A and B to shift. Inlet 1 is then connected to outlet 2 via crossflow passages C and D. Exhaust 3 is closed. Sensing pressure signals go to each pressure sensor and become equal to inlet pressure. Both sensors contacts open and no voltage signals are provided to the external monitoring system. This indicates that both sides of the valve actuated as expected.

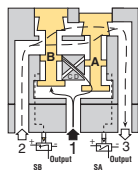

Detecting a Malfunction

A malfunction in the system or the valve itself could cause one valve element to be open and the other closed. Air then flows past the inlet poppet on valve element A, into crossflow passage D, but is substantially blocked by the spool portion of element B. The large size of the open exhaust passage past element B keeps the pressure at the outlet port below 2% of inlet pressure. Full sensing air pressure from side A goes to sensor SA, and a reduced pressure goes to sensor SB. This full pressure signal causes SA to open. Sensor SB, with a reduced pressure signal, does not open. An external monitoring system can detect the malfunction by monitoring the outputs of the SA and SB sensors. The external monitor system must then react accordingly by shutting down the power to the valve solenoids and any other components deemed necessary to stop the machine.



Machinery Directive - Overview

The Machinery Directives' goal is to protect people and the environment from accidents caused from all types of machinery. Based on the standard EN 13849 [safety of machines; safety-related parts of control systems] these standards build the procedure to assess safety-related control systems.

Required Performance Level (PLr) based on a risk assessment are now commonly used to determine the safety level required for the controls system, for the application of machinery.

Performance Level (PL) based on the original B, 1,2,3,4 safety categories, diagnostic capabilities, Mean time to dangerous failure (MTTFd), and common cause failure (CCF), define safety levels of a given safety function. This ensures that safety is not just focused on component reliability, but instead introduces common sense safety principles such as redundancy, diversity, and fail-safe behavior of safety related control parts.

The new EN 13849 standards of the Machinery Directive dictates the machine is safe when the Performance Level of the safety control circuit is equal to or greater than the Required Performance Level of the application. When determining the required performance level, the greater the risk, the higher the requirements of the control system.

$$PL_r \leq PL$$

Determining PLr According to EN 13849-1

The level of each hazardous situation is classified in five Performance levels from a to e. With PL a the control functions contribution to risk reduction is low, while at PL e it is high. The risk graph above can be used as a guideline to determine the required performance level PLr for safety function.

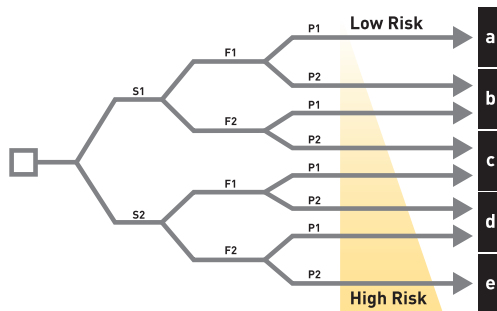

Risk Parameters

(S) Severity of injury

- S1 Slight (normally reversible injury)
- S2 Serious (normally irreversible injury, or death)

(F) Frequency and / or duration of exposure to hazard

- F1 Seldom to less often and / or brief
- F2 Frequent to continuous and / or long

(P) Possibility of avoiding the hazard

- P1 Possibility of avoiding the hazard
- P2 Scarcely ever possible

Determining PL According to EN 13849-1

Determining the MTTF_d = Mean Time To Dangerous Failure

Determining the PL = Performance Level	a								10 ⁻⁸ ≤ PFH _d < 10 ⁻⁷	Determining the SIL = Safety Integrity Level
	b								3 X 10 ⁻⁸ ≤ PFH _d < 10 ⁻⁷	
	c								10 ⁻⁸ ≤ PFH _d < 3 X 10 ⁻⁸	
	d								10 ⁻⁷ ≤ PFH _d < 10 ⁻⁶	
	e								10 ⁻⁶ ≤ PFH _d < 10 ⁻⁵	
	DC < 60% None	DC < 60% None	60% ≤ DC < 90% Low	90% ≤ DC < 99% Medium	60% ≤ DC < 90% Low	90% ≤ DC < 99% Medium	99% ≤ DC High			
	Cat. B	Cat. 1	Cat. 2		Cat. 3	Cat. 4				
	CCF not relevant		CCF ≥ 65%							

Categories Defined by EN 13849-1

Category	Summary
Category B	When a fault occurs it can lead to the loss of the safety function.
Category 1	Same that Category B, but loss of the safety function is less likely thanks to a good MTTF _d of each channel.
Category 2	System behavior allow that the occurrence of a fault can lead to the loss of the safety function between the checks; the loss of the safety function is detected by the check.
Category 3	A single fault in any of safety related parts does not lead to the loss of the safety function. Whenever reasonably possible the single fault shall be detected at or before the next demand upon the safety function. (Means redundancy)
Category 4	Same as Category 3, but if detection of single fault is not possible on or before the next demand upon the safety, an accumulation of these undetected faults shall not lead to the loss of the safety function. (Means redundancy & check)

Ball Valves / Lockout Valves

The Ball / Lockout Valve shuts off downstream line pressure in the closed position with a 90° turn of the handle. In the closed position, inlet air pressure is blocked and downstream / system air is exhausted through a threaded port. To prevent unauthorized adjustment, the padlock slide may be assembled on either side. It is recommended that this slide is installed after final system assembly.

The Safety Lockout valves conform to OSHA #29 CFR part 1910 — control of hazardous energy source (lockout / tagout).

Note: This padlock slide is a permanent assembly and may not be removed later, any unauthorized tampering will void any warranty claims. The valve can only be locked in the closed position.

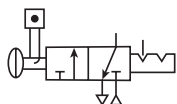
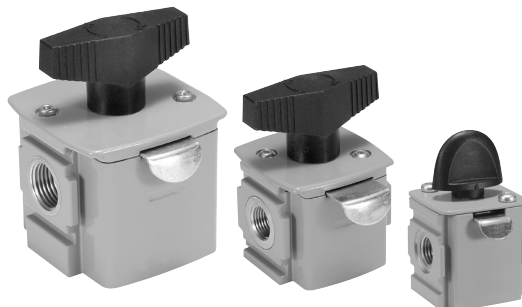

Ordering Information:

Model Type	Port Size	Exhaust Port	Flow scfm (dm ³ /s, ANR)	Modular Ball Valve Flow from Left to Right
P31	1/4"	1/4"	42.4 (20)	P31VB12LBNN
P32	3/8"	1/4"	190.7 (90)	P32VB13LBNN
	1/2"	1/4"	258.5 (122)	P32VB14LBNN
P33	1/2"	1/2"	561.5 (265)	P33VB14LBNN
	3/4"	1/2"	678 (320)	P33VB16LBNN

* Lockout tab and muffler supplied with unit.

For thread type:

BSPP	1
BSPT	2
NPT	9

Operating Information

Operating temperature:	-40°C to 80°C (-40°F to 176°F)
Pressure supply (max):	250 psig (17 bar)
Port size:	BSPP / BSPT / NPT
	1/4, 3/8, 1/2, 3/4
Weight:	P31 0.33 lbs (0.15 kg)
	P32 0.79 lbs (0.36 kg)
	P33 1.21 lbs (0.55 kg)

Material Specifications

Body	Aluminum
Seals	PTFE
Ball	Stainless Steel
Lockout Tab	Zinc Plated Steel
Screw	Zinc Plated Steel

Dimensions mm (inches)

P31

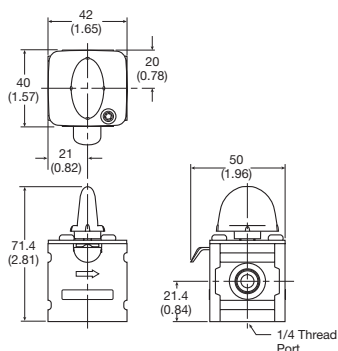

P32

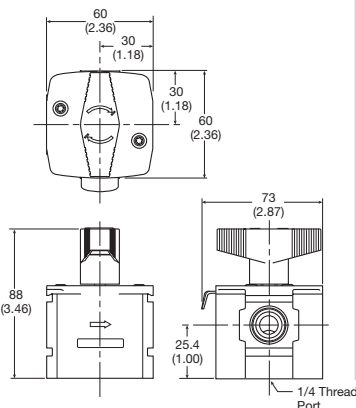

P33

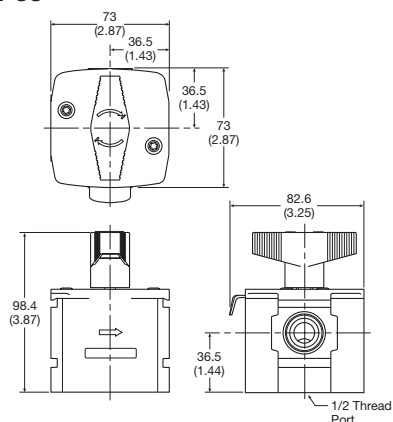

Manifold and Branch Blocks

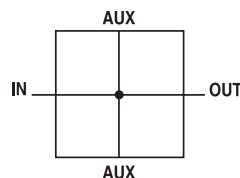

Features

- Available in 1/4, 1/2 & 3/4 threaded inlet / outlet ports
- Two additional top and bottom auxiliary ports standard
- Can be mounted anywhere in the FRL system
- Flow capacity: 1/4 66 dm³/s, 1/2 189 dm³/s, 3/4 305 dm³/s

Manifold Blocks

Model Type	In / Out Port Size	Auxiliary Port Size Top	Auxiliary Port Size Bottom	Thread Type	Order Code
P31	1/4"	1/4"	1/4"	BSPP	P31MA12022N
P32	1/2"	1/4"	1/2"	BSPP	P32MA14024N
P33	3/4"	1/4"	1/2"	BSPP	P33MA16024N

For thread type: BSPP **1** NPT **9**

Materials of Construction

Body Aluminium

Specifications

Max Operating Temperature	65.5°C (150°F)	
Max Supply Pressure	20.7 bar (300 psi)	
Weight	P31:	0.19 kg (0.42 lbs)
	P32:	0.30 kg (0.66 lbs)
	P33:	0.34 kg (0.75 lbs)

Manifold Block - Dimensions

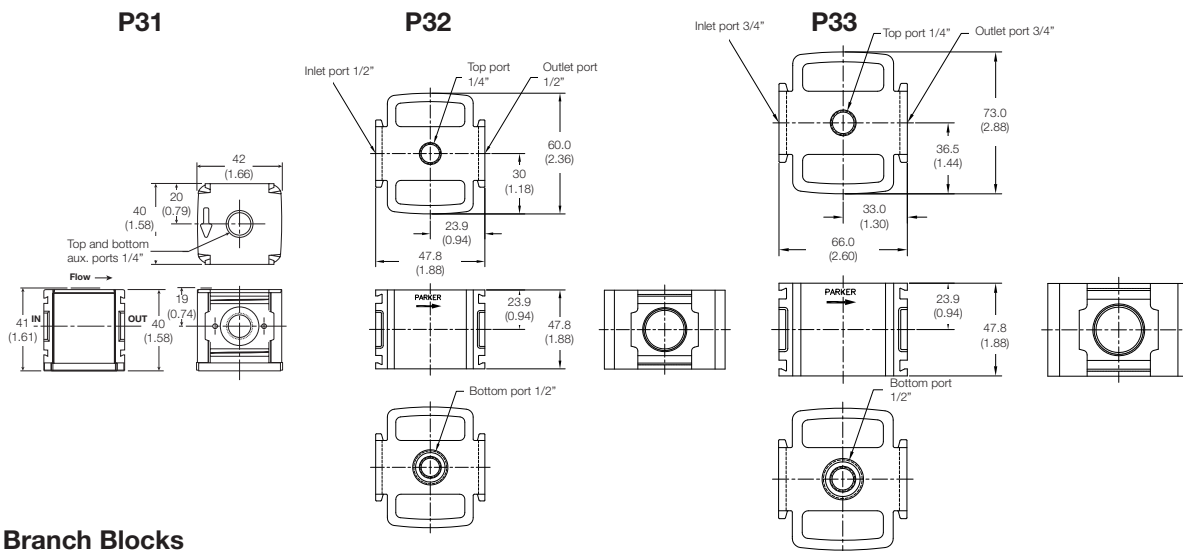

Branch Blocks

P32	1/2"	1/4"	1/4"	BSPP	P32MD14022N
P32	1/4"	1/4"	1/4"	BSPP	P32MD12022N

Materials of Construction

Body Aluminium

Specifications

Max Operating Temperature	65.5°C (150°F)
Max Supply Pressure	20.7 bar (300 psi)
Weight	0.14 kg (0.31 lbs)

Flow Capacity

1/4"	66 dm ³ /s (140 scfm)
1/2"	189 dm ³ /s (400 scfm)
3/4"	305 dm ³ /s (646 scfm)

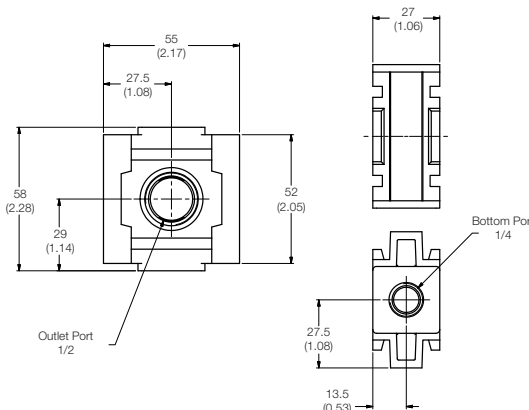

Analog Pressure Sensors

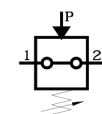

Break contact

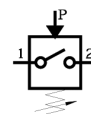

Make contact

Characteristics		Material	
Safety pressure relief P _{max}	300 bar	Housing	Passivated steel
Port size	G1/8, G1/4	Diaphragm	Buna N
Medium and ambient T _{max} temperature range	+100 °C	Switching function	
Switch back difference	Max. 5 - 15%	Make contact	Closes the circuit when the set pressure is reached
Voltage	Max. 48 V	Break contact	Interrupts the circuit when the set pressure is reached
Current	0.5 A		
Degree of protection	IP 65		
Switching frequency	Max. 200 s/min		

Order Code for Ordering

Order instructions Type	Port size A	Function	Setting range (bar)	Order code
PR / 0.1-1 NC ST 1/4 48	G1/4	Break contact	0.1-1	KL3439
PR / 0.1-1 NO ST 1/4 48	G1/4	Make contact	0.1-1	KL3440
PR / 1-10 NC ST 1/8 48	G1/8	Break contact	1-10	KL3437
PR / 1-10 NC ST 1/4 48	G1/4	Break contact	1-10	KL3436
PR / 1-10 NO ST 1/8 48	G1/8	Make contact	1-10	KL3438
PR / 1-10 NO ST 1/4 48	G1/4	Make contact	1-10	KL3435

Order instructions Type	Port size A	Function	Setting range (bar)	Order code
PR / 0.2-1 NO SR 1/4 48	G1/4	Make contact	0.2-1	KL3445
PR / 0.1-1 NC SR 1/4 48	G1/4	Break contact	0.1-1	KL3454
PR / 0.1-1 NO SR 1/4 48	G1/4	Make contact	0.1-1	KL3455
PR / 1-10 NC SR 1/8 48	G1/8	Break contact	1-10	KL3452
PR / 1-10 NC SR 1/4 48	G1/4	Break contact	1-10	KL3451
PR / 1-10 NO SR 1/8 48	G1/8	Make contact	1-10	KL3453
PR / 1-10 NO SR 1/4 48	G1/4	Make contact	1-10	KL3450

Plug can be turned 90°

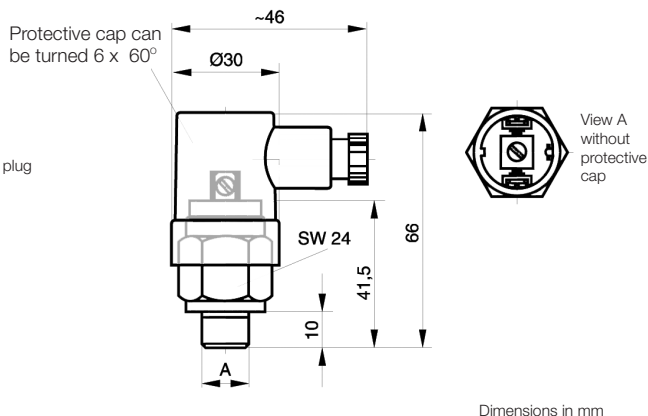
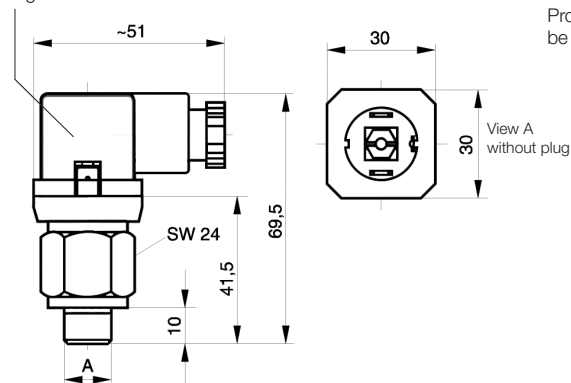

Dimensions in mm

P31 Accessories

C-Bracket
(Fits to filter and lubricator body)
P31KA00MW

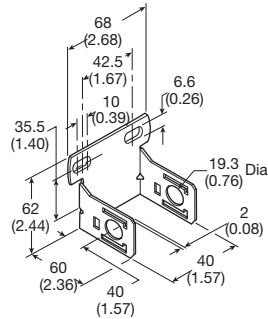
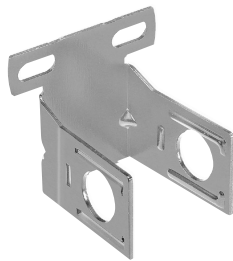

T-Bracket w/ Body Connector
(O-ring not shown)
P31KA00MT

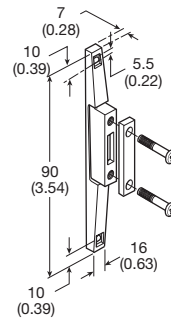

Body Connector
(O-ring not shown)
P31KA00CB

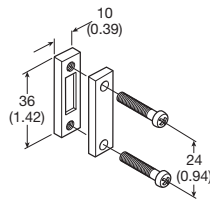

Port Block Kit
(O-ring not shown)

1/8 NPT	P31KA91CP	1/8 BSPT	P31KA21CP
1/4 NPT	P31KA92CP	1/4 BSPT	P31KA22CP
3/8 NPT	P31KA93CP	3/8 BSPT	P31KA23CP
1/8 BSPP	P31KA11CP		
1/4 BSPP	P31KA12CP		
3/8 BSPP	P31KA13CP		



Port Block Kit w/ T-Bracket
(O-ring not shown)

1/8 NPT	P31KA91CN	1/8 BSPT	P31KA21CN
1/4 NPT	P31KA92CN	1/4 BSPT	P31KA22CN
3/8 NPT	P31KA93CN	3/8 BSPT	P31KA23CN
1/8 BSPP	P31KA11CN		
1/4 BSPP	P31KA12CN		
3/8 BSPP	P31KA13CN		



Angle Bracket
(Fits to regulator and filter/regulator body)
P31KB00MR

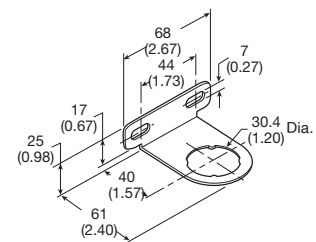

P32 Accessories

T-Bracket w/ Body Connector P32KA00MT

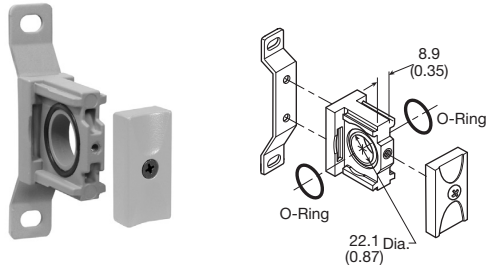

Body Connector P32KA00CB

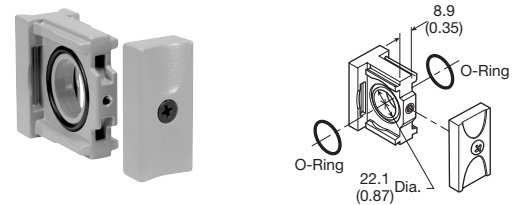

Port Block Kit

1/4 NPT.....	P32KA92CP	1/4 BSPT	P32KA22CP
3/8 NPT.....	P32KA93CP	3/8 BSPT	P32KA23CP
1/2 NPT.....	P32KA94CP	1/2 BSPT	P32KA24CP
3/4 NPT.....	P32KA96CP	3/4 BSPT	P32KA26CP
1/4 BSPP	P32KA12CP		
3/8 BSPP	P32KA13CP		
1/2 BSPP	P32KA14CP		
3/4 BSPP	P32KA16CP		



Angle Bracket (Fits to regulator and filter/regulator bonnet) P32KB00MR

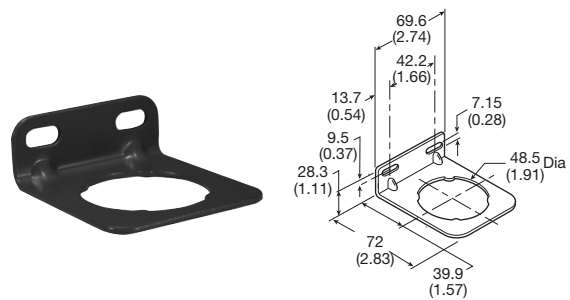

L-Bracket (Fits to filter and lubricator body) P32KA00ML

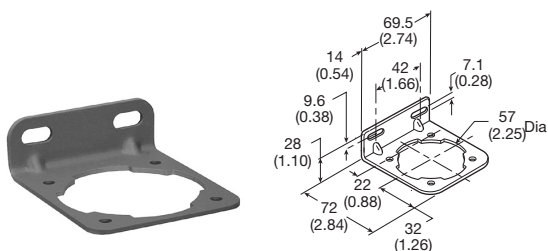

T-Bracket (fits to body connector or port block) P32KA00MB

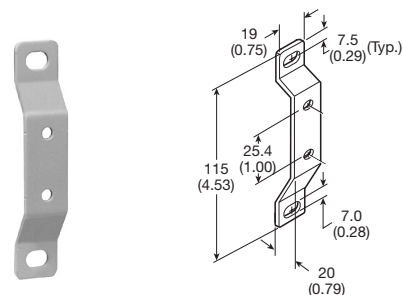

P33 Accessories

T-Bracket w/ Body Connector P32KA00MT

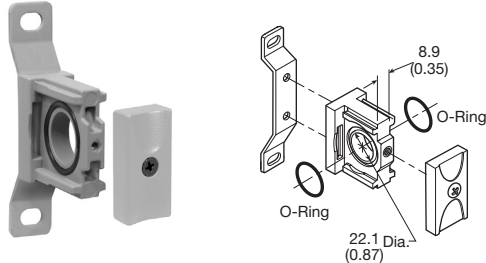

Body Connector P32KA00CB

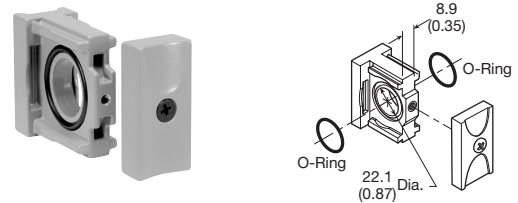

Port Block Kit

1/4 NPT.....	P32KA92CP	1/4 BSPT	P32KA22CP
3/8 NPT.....	P32KA93CP	3/8 BSPT	P32KA23CP
1/2 NPT.....	P32KA94CP	1/2 BSPT	P32KA24CP
3/4 NPT.....	P32KA96CP	3/4 BSPT	P32KA26CP
1/4 BSPP	P32KA12CP		
3/8 BSPP	P32KA13CP		
1/2 BSPP	P32KA14CP		
3/4 BSPP	P32KA16CP		



Angle Bracket (Fits to regulator and filter/regulator bonnet)

P33KA00MR

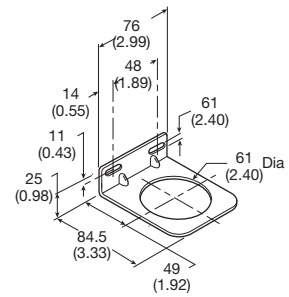



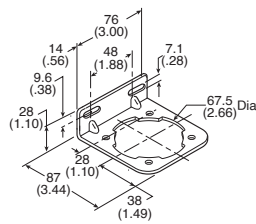



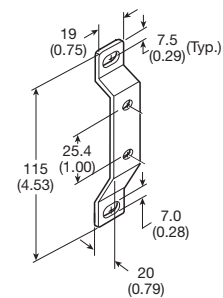



L-Bracket (Fits to filter and lubricator body) P33KA00ML



T-Bracket (fits to body connector or port block) P32KA00MB













Series	Description	Part Number	
P31 P32 P33	Panel Mount Nut (Plastic)	P31KA00MP P32KA00MP P33KA00MP	
P31 P32 P33	Panel Mount Nut (Aluminum)	P31KA00MM P32KA00MM P33KA00MM	
P31 P32 P33	5µ Element Kit	P31KA00ESE P32KA00ESE P33KA00ESE	
P31 P32 P33	1µ Element Kit	P31KA00ES9 P32KA00ES9 P33KA00ES9	
P31 P32 P33	0.01µ Element Kit	P31KA00ESC P32KA00ESC P33KA00ESC	
P31 P32 P33	Adsorber Element Kit	P31KA00ESA P32KA00ESA P33KA00ESA	
P32 / P33	Auto Drain Kit	P32KA00DA	
P31 P32 / P33	Differential Pressure Indicator Kit	P31KB00RQ P32KA00RQ	
P31 / P32 / P33	Drip Control Assembly Kit	P32KA00PH	
P31 P32 / P33	Fill Plug Kit	P31KA00PL P32KA00PL	
P31 P32 P33	Lubricator - Plastic Bowl w/ Bowl Guard No Drain	P31KB00BGN P32KB00BGN P33KA00BGN	

Options in grey are not available or not stocked in EMEA region

PDE2676TCUK

Global FRL and P3Y Series

**P31, P32, P33 Series
Accessories**

Series	Description	Part Number	
P31 P32 P33	Lubricator - Metal Bowl w/o Sight Gauge No Drain	P31KB00BMN P32KB00BMN P33KA00BMN	
P32 P33	Lubricator - Metal Bowl w/ Sight Gauge No Drain	P32KB00BSN P33KA00BSN	
P31 P32 P33	Metal Bowl w/o Sight Gauge & Manual Drain	P31KB00BMM P32KB00BMM P33KA00BMM	
P31	Metal Bowl w/o Sight Gauge & Pulse Drain	P31KB00BMB	
P32 P33	Metal Bowl w/o Sight Gauge & Auto Drain	P32KB00BMA P33KA00BMA	
P32 P33	Metal Bowl w/ Sight Gauge & Manual Drain	P32KB00BSM P33KA00BSM	
P32 P33	Metal Bowl w/ Sight Gauge & Auto Drain	P32KB00BSA P33KA00BSA	
P31 P32 P33	Plastic Bowl w/ Bowl Guard & Manual Drain	P31KB00BGM P32KB00BGM P33KA00BGM	
P31	Plastic Bowl w/ Bowl Guard & Pulse Drain	P31KB00BGB	
P32 P33	Plastic Bowl w/ Bowl Guard & Auto Drain	P32KB00BGA P33KA00BGA	
P31 P32 P33	Regulator - Relieving Repair Kit	P31KB00RB P32KB00RB P33KA00RB	
P31 P32 P33	Regulator - Non-Relieving Repair Kit	P31KB00RC P32KB00RC P33KA00RC	

Options in grey are not available or not stocked in EMEA region

Series	Description	Connection	Part Number	
P31 P32 P33	Regulator - Main Adjusting Spring 0-30 psig (0-2 bar) Kit		P31KB00PR	
			P32KB00PR	
			P33KA00PR	
P31 P32 P33	Regulator - Main Adjusting Spring 0-60 psig (0-4.1 bar) Kit		P31KB00PS	
			P32KB00PS	
			P33KA00PS	
P31 P32 P33	Regulator - Main Adjusting Spring 0-125 psig (0-8.6 bar) Kit		P31KB00PT	
			P32KB00PT	
			P33KA00PT	
P31 P32 P33	Regulator - Main Adjusting Spring 0-250 psig (0-17 bar) Kit		P31KB00PV	
			P32KB00PV	
			P33KA00PV	
P31	Square Flush Mounting Gauge Kit	0-60 psig	K4511SCR060	
		0-160 psig	K4511SCR160	
		0-4 bar	K4511SCR04B	
		0-11 bar	K4511SCR11B	
P31 / P32	Square Mounting Gauge with Adapter Kit	0-60 psig	P6G-PR90060	
		0-160 psig	P6G-PR90160	
		0-4 bar	P6G-PR10040	
		0-11 bar	P6G-PR10110	
P31 / P32 / P33	MPS-34 Digital Sensor	0-10 bar / PNP with 4-20mA / M8 4 Pin	MPS-P34G-PCI	
P31 / P32 / P33	Cable	M8 4 Pin 2 meter	CB-M8-4P-2M-PUR	
P33		M8 4 Pin 5 meter	CB-M8-4P-5M-PUR	
P32/P33	Air port Gauge	Adaptor 1/8BSP to 1/4BSP	01781310	
P31	40mm Round Gauge	0-60 psig / 0-4 bar 1/8"	P3D-KAB1ALN	
		0-140 psig / 0-10 bar 1/8"	P3D-KAB1ANN	
		0-280 psig / 0-20 bar 1/8"	P3D-KAB1AHN	
P32 / P33	50mm Round Gauge	0-60 psig / 0-4 bar 1/4"	P6G-ERB2040	
		0-160 psig / 0-11 bar 1/4"	P6G-ERB2110	
		0-300 psig / 0-20 bar 1/4"	P6G-ERB2200	
P31 P32 / P33	Body Connector O-ring (Replacement kit) (Pack of 10)		P31KA00CY P32KA00CY	
P31 P32	Tamperproof Knob Kit		P31KB00AT P32KB00AT	
P31 P32	Tamperproof Lockable Kit		P31KB00AL P32KB00AL	

Options in grey are not available or not stocked in EMEA region

Solenoid Operators - CNOMO

Solenoid Operators, Coil Combinations

	NC Normal Operator with 22 x 30 standard coil	NC Normal Operator with 30 x 30 standard coil
Working pressure	0 to 10 bar	0 to 10 bar
Ambient temperature	-10°C to 60°C *	-10°C to 60°C *
Power (DC)	4.8W	2.7W
Power (AC)	8.5VA	4.9VA
Voltage tolerance	+/-10%	+/-10%
Duty cycle	100%	100%
Insulation class	F	F
Electric connection	B Industrial	DIN 43650A
Protection	IP65	IP65
Approval		UL/CSA
Working media	All neutral media such as compressed air	

* Limited to 50°C if use with 100% duty cycle

P31 Series only - Solenoid coils 15mm NC

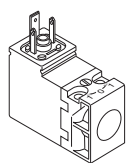

Voltage	Order code Override, blue, Non-Locking Flush	Weight (kg)
24VDC	P2E-KV32C1	0.038
115VAC 50Hz / 120VAC 60Hz	P2E-KV31F1	0.038

Solenoid Coils with M12 Connection

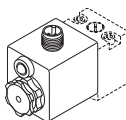

Voltage	Part Number	Weight (kg)
Direct current		
24VDC	P2FC6449	0.065

Solenoid Coils with DIN A or Industrial B Connection

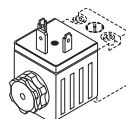

Voltage	22mm x 30mm Part Number B Industrial Standard	Weight (kg)	30mm x 30mm Part Number DIN 43650A Standard	Weight (kg)
Direct current				
24VDC	P2FCB449	0.093	P2FCA449	0.105
Alternative current				
110V 50Hz, 120V 60Hz	P2FCB453	0.093	P2FCA453	0.105

Transients

Interrupting the current through the solenoid coil produces momentary voltage peaks which, under unfavorable conditions, can amount to several hundred times the rated operating voltage. Normally, these transients do not cause problems, but to achieve the Maximum life of relays in the circuit (and particularly of transistors, thyristors and integrated circuits) it is desirable to provide protection by means of voltage-dependent resistors (varistors). All connectors/cable plugs EN175301-803 with LED's include this type of circuit protection.

Materials

Pilot Valve

Body:	Polyamide
Armature tube:	Brass
Plunger & core:	Corrosion resistant Cr-Ni steel
Seals:	Fluorocarbon
Screws:	Stainless steel

Coil

Encapsulation material:	Thermoplastic as standard Duroplast for M12 connection
-------------------------	-----------------------------------------------------------

Spare Base Solenoid Pilot Operator CNOMO NC

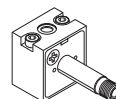

Description	Part Number Non-Lock Manual Override	Weight (kg)
Standard Duty	P2FP23N4B	0.065
No Override	P2FP23N4A	0.065

Note: Solenoid pilot operators are fitted to the Global range. Order the above part numbers for spares. The operators are supplied with mounting screws and interface 'O' rings. Coils and connectors must be ordered separately.

Solenoid Connectors / Cable Plugs EN175301-803

	Description	Order code 15mm Form C ISO15217	Order code 22mm Form B Industrial	Order code 30mm Form A ISO4400
With large headed screw suitable for mounting in inaccessible or recess position		Standard IP65	P8C-C	
		24V DC LED and protection IP65	P8C-C26C	
		110V AC LED and protection IP65	P8C-C21E	
With standard screw		Standard IP65 without flying lead	P8C-D	3EV10V10
		With LED and protection 24V AC/DC	P8C-D26C	3EV10V20-24
		With LED and protection 110V AC	P8C-D21E	3EV10V20-110
		With LED and protection 230V AC		3EV10V20-230
With cable		Standard with 2m cable IP65	P8L-C2	
		Standard with 5m cable IP65	P8L-C5	
		24V AC/DC, 2m cable LED and protection IP65	P8L-C226C	
		24V AC/DC, 5m cable LED and protection IP65	P8L-C526C	3EV10V20-24L5
		24V AC/DC, 10m cable LED and protection IP65	P8L-CA26C	
		110V AC/DC, 2m cable LED and protection IP65	P8L-C221E	
		110V AC/DC, 5m cable LED and protection IP65	P8L-C521E	3EV10V20-110L5
		230V AC, 5m cable LED and protection IP65		3EV10V20-230L5

Solenoid Coil & Cable Plug Dimensions (mm)

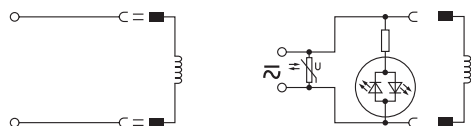
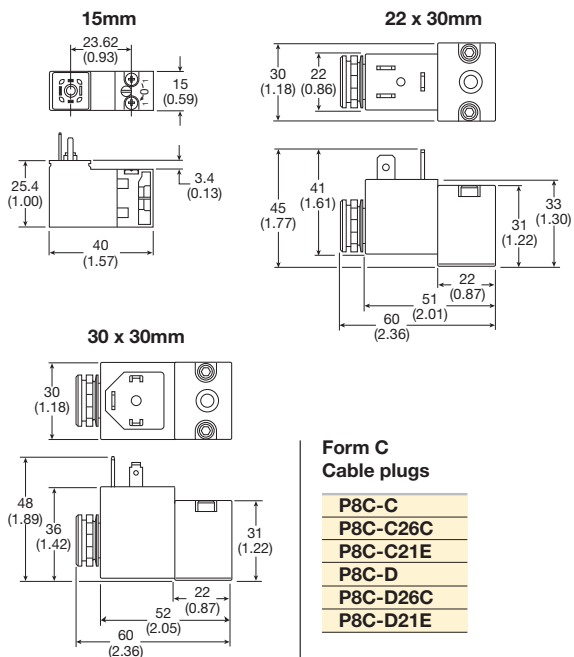

P8C-C	P8C-D26C	P8L-C226C
P8C-D	P8C-D21E	P8L-C526C
P8L-C2	P8C-C26C	P8L-CA26C
P8L-C5	P8C-C21E	P8L-C221E
3EV10V10		P8L-C521E
	3EV10V20-24	3EV10V20-24L5
	3EV10V20-110	3EV10V20-110L5
	3EV10V20-230	3EV10V20-230L5

Form C Cable plugs

P8C-C
P8C-C26C
P8C-C21E
P8C-D
P8C-D26C
P8C-D21E

Form C Cable plugs

P8L-C2
P8L-C5
P8L-C226C
P8L-C526C
P8L-CA26C
P8L-C221E
P8L-C521E

Form B Cable plugs

3EV10V10

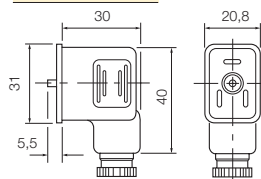

Form A Cable plugs

3EV290V10

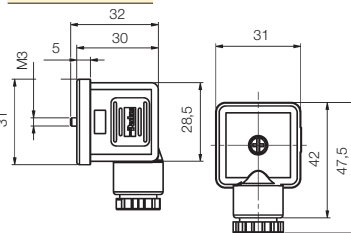

P3Y System

The P3Y system allows units to be connected together without the use of pipe connectors. This saves space, provides constant mounting centers, and maintains a modern aesthetically pleasing appearance.

The P3Y filters are specially designed to efficiently filter out rust, dirt, moisture and other impurities from compressed air lines. Operation is fully automatic with a minimum of pressure drop. Coalescing filters and adsorber filters for high purity air are also included in the P3Y series.

The P3Y regulators are designed to provide quick response and accurate pressure regulation for the most demanding hi-flow industrial applications.

The rolling diaphragm was designed for long trouble-free operation and will not rupture or tear under high cycle or demanding applications. The P3Y mist lubricators are designed to provide lubrication for many general purpose applications.

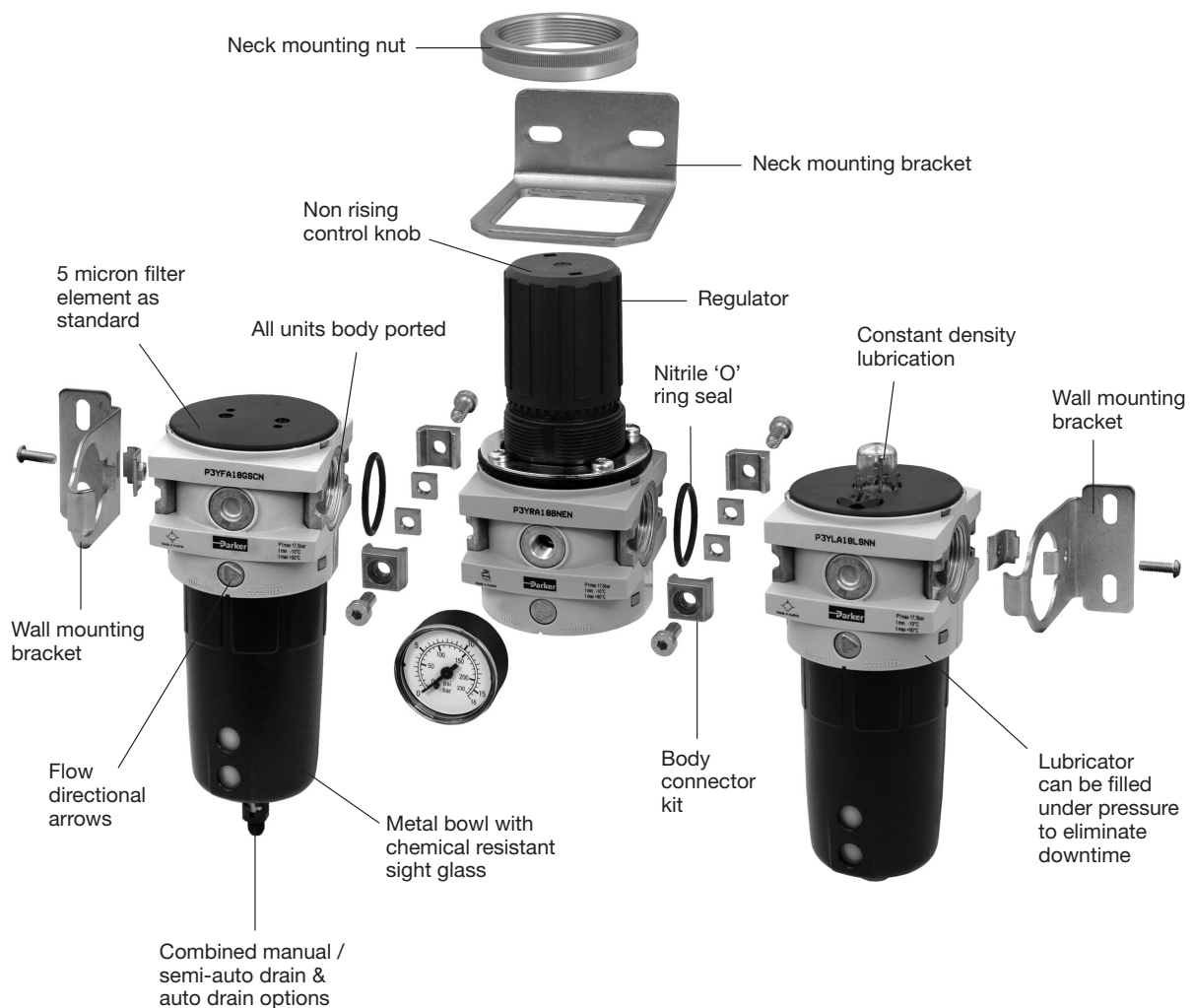

P3Y Particulate Filter - Large

- Integral 3/4" or 1" ports (NPT & BSPP)
- High efficiency particulate element as standard
- Excellent water removal efficiency
- Robust but lightweight aluminium construction
- Low temperature -40°C (-40°F) with combined manual / semi-auto drain as standard

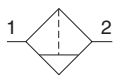

Manual drain



Auto drain

Port Size	Description	Part Number
3/4"	Combined Manual /Semi-Auto Drain	P3YFA16ESCN
3/4"	Auto Drain	P3YFA16ESAN
1"	Combined Manual /Semi Auto Drain	P3YFA18ESCN
1"	Auto Drain	P3YFA18ESAN

Operating Information

Supply pressure (max)*:	254 psig (17.5 bar)
Operating temperature:	
Auto drain	14°F to 140°F (-10°C to 60°C)
Combined drain	-40°F to 140°F (-40°C to 60°C)
Standard filtration	5 micron
Manual / semi-auto drain:	Closed at 11.6 psig (0.8 bar) G1/8 thread male
Auto drain bowl pressure:	Closed at 11.6 psig (0.8 bar)
Bowl capacity:	4.4 US oz. (130 cm ³)
Standard filtration:	5 micron
Flow capacity†:	3/4" 170 scfm (80.2 dm ³ /s, ANR) 1" 170 scfm (80.2 dm ³ /s, ANR)
Fluid:	Compressed air
Weight:	1.98 lb (0.9 kg)

† Inlet pressure 91.4 psig (6.3 bar) inlet pressure and 7.3 psig (0.5 bar) pressure drop.

* Air supply must be dry enough to avoid ice formation at temperatures below 35.6°F (2°C).

Air quality: Within ISO 8573-1: 2010 Class 6 and 7 (Particulates)

Ordering Information:

P3YFA		1	6	E	SC	N
Basic Series	Thread Type*	Port Size	Element	Drain Type		
Filter P3YFA	BSPP 1	3/4 6	E 5 micron	SC	Combined Manual / Semi-Auto Drain	
	NPT 9	1 8	G 30 micron	SA	Auto drain	

* Note: For 1-1/2" ported unit, please order P3YKA*BCP port block kit separately.

Options in grey boxes are not available or not stocked in EMEA region

Material Specifications

Body	Aluminium
Sight glass and bowl	Polypropylene
Body cover	ABS
Element	Sintered P.E.
Seals	Nitrile NBR
Manual / semi-auto drain	Acetal
Automatic drain	PA / Ø 10mm brass connection

Repair and Service Kits

5 micron element kit	P3YKA00ESE
30 micron element kit	P3YKA00ESG
Bowl kit with combined manual / semi auto drain	P3YKA00BSC
Bowl kit with auto drain	P3YKA00BSA

Flow Characteristics

(3/4") Filter 5 micron

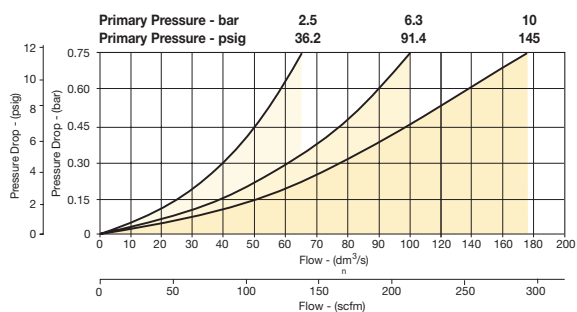

(1") Filter 5 micron

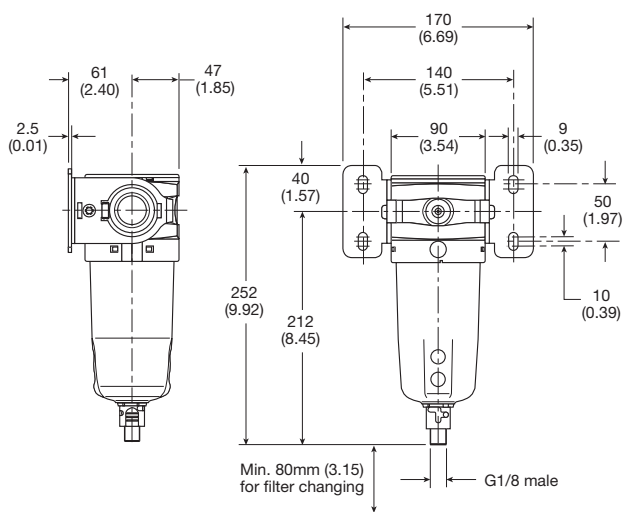
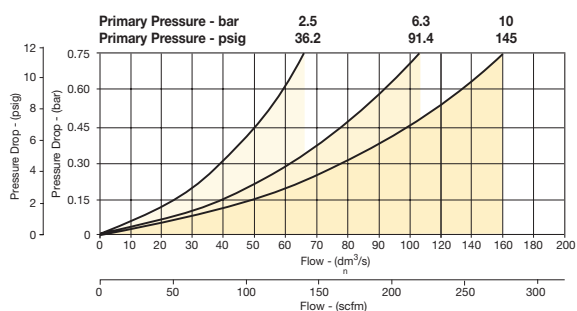

mm (Inches)

P3Y Coalescing and Adsorber Filters - Large

- Extended high efficiency filter element provides greater filtration surface area.
- Integral 3/4" or 1" ports (BSPP & NPT)
- Removes liquid aerosols and sub micron particles
- Oil free air for critical applications, such as air gauging, pneumatic instrumentation and control
- Adsorber activated carbon element removes oil vapors and most hydrocarbons
- Robust but lightweight aluminum construction



Notes: To optimize the life of the coalescing element, it is advisable to install a P3YFA pre-filter with a 5 micron element upstream of the coalescing filter.

To optimize the life of the adsorber element, it is advisable to install a P3Y coalescing 0.01 micron filter upstream of the adsorber filter.

Port Size	Description	Part Number
3/4"	Coalescing Filter 0.01 micron, Combined Manual / Semi-Auto Drain	P3YFA16DSCN
3/4"	Coalescing Filter 0.01 micron, Auto Drain	P3YFA16DSAN
1"	Coalescing Filter 0.01 micron, Combined Manual / Semi-Auto Drain	P3YFA18DSCN
1"	Coalescing Filter 0.01 micron, Auto Drain	P3YFA18DSAN

Operating Information

Supply pressure (max)*:	254 psig (17.5 bar)
Operating temperature:	14°F to 140°F (-10°C to 60°C)
Manual / auto drain:	Closed at 11.6 psig (0.8 bar) G1/8 thread male
Media specifications:	
Adsorber, max oil carryover	0.008 mg/m ³ (PPM w/w)
Bowl capacity:	4.4 US oz. (130 cm ³)
Standard filtration:	0.01 micron
Flow capacity†:	
3/4" 1.0 micron coalescing	290 scfm (137 dm ³ /s, ANR)
1" 1.0 micron coalescing	307 scfm (145 dm ³ /s, ANR)
3/4" 0.01 micron coalescing	275 (177 dm ³ /s, ANR)
1" 0.01 micron coalescing	307 (145 dm ³ /s, ANR)
3/4" Activated carbon adsorber	275 (177 dm ³ /s, ANR)
1" Activated carbon adsorber	307 (145 dm ³ /s, ANR)
Fluid:	Compressed air
Weight:	3.5 lb (1.6 kg)
† Inlet pressure 91.4 psig (6.3 bar) inlet pressure and 7.3 psig (0.5 bar) pressure.	
* Air supply must be dry enough to avoid ice formation at temperatures below 35.6°F (2°C).	

Air quality: ISO 8573-1:2010: 0.01µm closes to Class 1 for maximum particle size and concentration of solid contaminants, and closes to Class 1 on maximum oil content (ppm/wt). Within ISO 8573-1:2010: Adsorber closes to Class 1 on maximum oil content (ppm/wt).

Ordering Information:

P3YFA		1	6	D	SC	N
Basic Series	Thread Type*	Port Size	Element	Drain Type		
Coalescing Filter P3YFA	BSPP 1 NPT 9	3/4 6 1 8	D 0.01 micron Element with DPI Standard A Adsorber 2 1 Micron	SC Combined Manual / Semi Auto Drain SA Auto Drain		

* Note: For 1-1/2" ported unit, please order P3YKA*BCP port block kit separately.

Options in grey boxes are not available or not stocked in EMEA region

Material Specifications

Body	Aluminium
Sight glass and bowl	Polypropylene
Filter cover	ABS
Coalescing element	Borosilicate & nano fibers
Top & bottom end cap (coalescing)	Aluminium
Adsorber element	Activated carbon
Top & bottom end cap (adsorber)	Glass filled nylon
Support cylinders	Grade 430 stainless steel
Support media	Polypropylene
Anti re-entrainment barrier	Polyester
Encapsulation	Epoxy resin / hardener
Seals	Nitrile NBR
Manual / semi-auto drain	Acetal
Auto drain	PA / Ø 10mm brass connection
Differential pressure indicator, body	Acetal
Differential pressure indicator, internal parts	Acetal
Differential pressure indicator, spring	Stainless steel
Differential pressure indicator, seals	Nitrile NBR
Differential pressure indicator, support plate	ABS
Differential pressure indicator, screws	Steel / zinc plated

Repair and Service Kits

0.01 micron element kit	P3YKA00ESC
Adsorber element kit	P3YKA00ESA
1 micron coalescing element kit	P3YKA00ES9
Bowl kit with combined manual / semi auto drain	P3YKA00BSC
Bowl kit with auto drain	P3YKA00BSA
Differential pressure indicator kit	P3YKA00RQ

Flow Characteristics

(3/4") 0.01 Micron Coalescing Filter Saturated

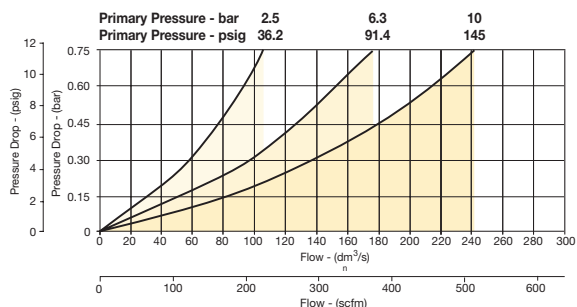

(1") 0.01 Micron Coalescing Filter Saturated

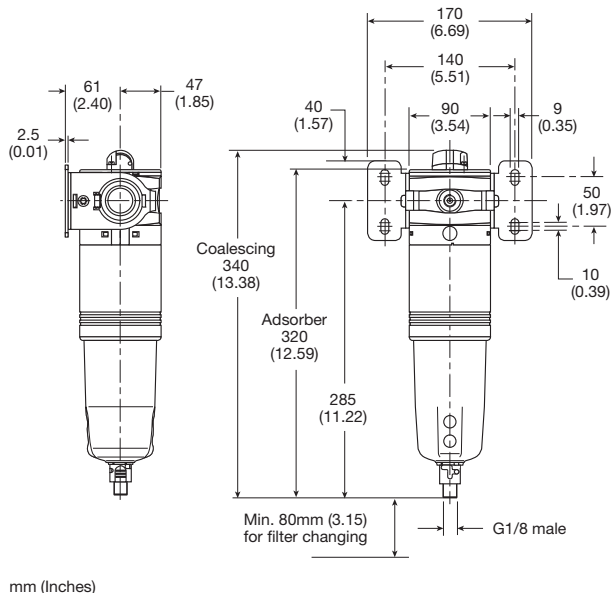
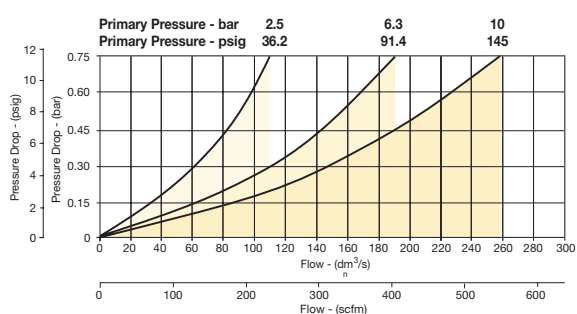

P3Y Regulators - Large

- Integral 3/4" or 1" ports (BSPP and NPT)
- Robust but lightweight aluminium construction
- Secondary pressure ranges 12 and 16 bar
- Rolling diaphragm for extended life
- Secondary aspiration plus rolling diaphragm provides quick response and accurate pressure regulation
- Optional tamperproof regulator padlock
- Reverse flow / relieving option
- Low temperature -40°C (-40°F)

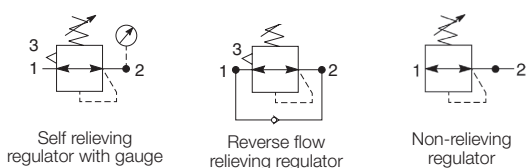

Port Size	Description	Part Number
3/4"	174 psig relieving	P3YRA16BNEN
3/4"	174 psig relieving + pressure gauge	P3YRA16BNFN
1"	174 psig relieving	P3YRA18BNEN
1"	174 psig relieving + pressure gauge	P3YRA18BNFN

Operating Information

Supply pressure (max)*:	254 psig (17.5 bar)
Operating temperature:	-40°F to 140°F (-40°C to 60°C)
Flow capacity†:	3/4" 380 scfm (179.3 dm³/s, ANR) 1" 550 scfm (259.6 dm³/s, ANR)
Fluid:	Compressed air
Gauge port (x2):	1/4"
Weight:	2.4 lb (1.08 kg)

† Inlet pressure 145 psig (10 bar) inlet pressure, 91.4 psig (6.3 bar) set pressure and 7.3 psig (0.5 bar) pressure drop.

* Air supply must be dry enough to avoid ice formation at temperatures below 35.6°F (2°C).

Ordering Information:

Basic Series		Thread Type*		Port Size		Relief		Lockable		Adjustment Range	
Regulator	P3YRA	BSPP	1	3/4	6	B	Relieving	N	Standard	E	0 to 174 psi (0 to 12 bar), No Gauge
		NPT	9	1	8	R	Reverse Flow / Relieving	A†	Lockable	H	0 to 232 psi (0 to 16 bar), No Gauge
										F	0 to 174 psi (0 to 12 bar), Gauge
										J	0 to 232 psi (0 to 16 bar), Gauge

Notes:
 * For 1-1/2" ported unit, please order P3YKA*BCP port block kit separately.
 † Not field convertible.

Options in grey boxes are not available or not stocked in EMEA region

Material Specifications

Body	Aluminium
Bonnet	Glass filled polyamide
Regulator cover	ABS
Control knob	Glass filled polyamide
Valve	Brass / NBR
Seals	Nitrile NBR
Screws	Steel / zinc plated

Repair and Service Kits

Angle bracket + metal lock ring	P3YKA00MS
Panel mounting nut	P3YKA00MM
Diaphragm kit (relieving type)	P3YKA00RR
Diaphragm kit (non-relieving type)	P3YKA00RN
0 to 300 psig (0 to 20 bar), gauge 1/4" port	P6G-ERB2200

⚠ WARNING

**Product rupture can cause serious injury.
Do not connect regulator to bottled gas.
Do not exceed Maximum primary pressure rating.**

CAUTION:

REGULATOR PRESSURE ADJUSTMENT – The working range of knob adjustment is designed to permit outlet pressures within their full range. Pressure adjustment beyond this range is also possible because the knob is not a limiting device. This is a common characteristic of most industrial regulators, and limiting devices may be obtained only by special design. For best performance, regulated pressure should always be set by increasing the pressure up to the desired setting.

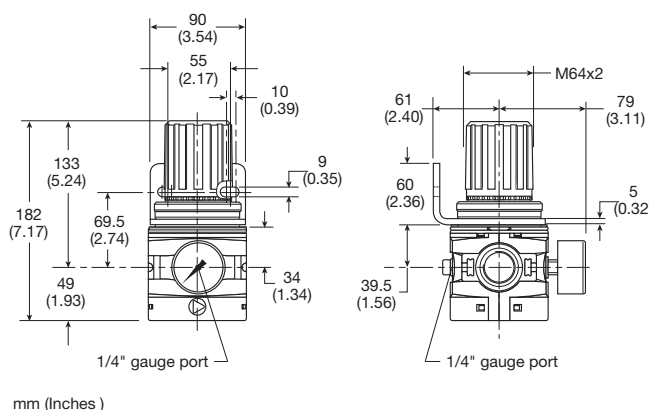

Flow Characteristics

(3/4") Regulator

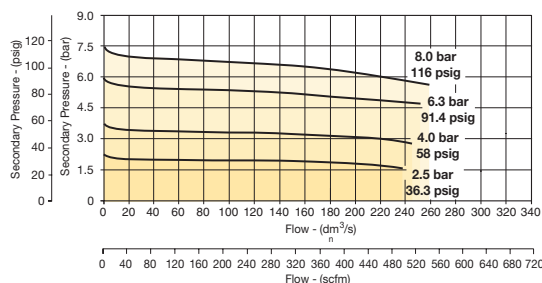

(1") Regulator

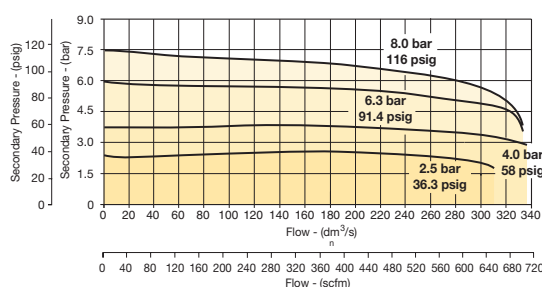

P3Y Pilot Operated Regulator - Large

- Integral 3/4" or 1" ports (BSPP & NPT)
- Pilot controlled regulators can be mounted "out of reach" with pilot regulator installed in a convenient location
- Constant pilot bleed control for accurate pressure control
- Balanced poppet provides quick response
- High flow

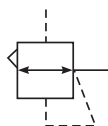

Port Size	Description	Part Number
3/4"	Pilot operated regulator	P3YRA16BPPN
1"	Pilot operated regulator	P3YRA18BPPN

Operating Information

Supply pressure (max):	254 psig (17.5 bar)
Operating temperature:	-40°F to 140°F (-40°C to 60°C)
Flow capacity [†] :	3/4" 550 scfm (259.6 dm ³ /s, ANR) 1" 550 scfm (259.6 dm ³ /s, ANR)
Fluid:	Compressed air
Weight:	2.6 lb (1.2 kg)

[†] Inlet pressure 145 psig (10 bar) inlet pressure, 91.4 psig (6.3 bar) set pressure and 7.3 psig (0.5 bar) pressure drop.

Ordering Information:

P3YRA		1	6	BPPN
Basic Series	Thread Type*	Port Size		
Pilot Operated Regulator P3YRA	BSPP 1	3/4 6		
	NPT 9	1 8		

* Note: For 1-1/2" ported unit, please order P3YKA*BCP port block kit separately.

Options in grey boxes are not available or not stocked in EMEA region

Material Specifications

Body	Aluminium
Body cover	ABS
Valve	Brass / NBR composite
Pilot valve booster	Aluminium
Seals	Nitrile NBR
Screws	Zinc plated steel

Flow Characteristics

3/4" and 1" Pilot Regulator

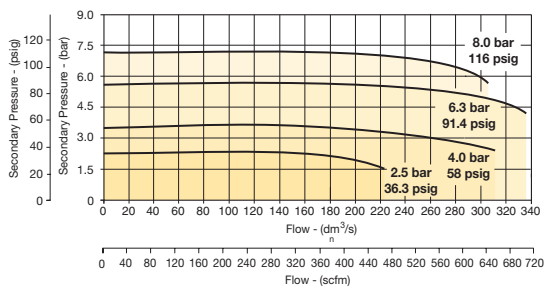

⚠ WARNING
Product rupture can cause serious injury.
Do not connect regulator to bottled gas.
Do not exceed Maximum primary pressure rating.

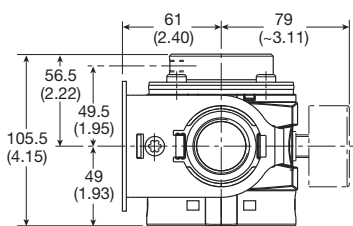
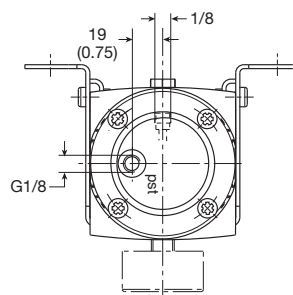

mm (Inches)

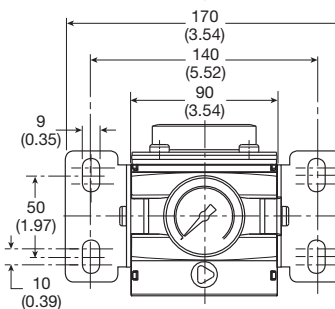

P3Y Proportional Pressure Regulator - Large

- Integral 3/4" or 1" ports (BSPP & NPT)
- Accurate output pressure
- Very fast response times
- Robust but lightweight design



Port Size	Description	Part Number
3/4"	Normally Closed, 0 - 10 bar (0 to 145 psig)	P3YPA16BD2VA2A
1"	Normally Closed, 0 - 10 bar (0 to 145 psig)	P3YPA18BD2VA2A

Operating Information

Operating pressure: P ¹ min	14.5 psig (1 bar)	Power consumption: I _{Bmax}	0.15 A
Inlet pressure ¹ : P ¹ max	232 psig (16 bar)	Set value input: U _w	V 0-10
Operating pressure: P ² min	2.9 psig (0.2 bar)	I	mA 0-20
Outlet pressure: P ² max	145 psig (10 bar)		mA 4-20
Operating temperature:	32°F to 122°F (0°C to 50°C)	Input resistance: R _E	243 K Ω
Flow capacity ¹ :	706 scfm (33.2 dm ³ /s, ANR)	Actual valve output: U _x	0 - 10 V
	l/min 20000	Output current: I _{Amax}	10 mA
	m ³ /h 1200	Degree of protection:	IP65 to DIN 40050, EN 60529
Hysteresis: P ² max	< 1%	Fluid:	Compressed air
Repeatability: P ² max	< 0.5%	Weight:	1.2 lb (2.7 kg)
Sensitivity: P ² max	< 0.5%		
Linearity: P ² max	< 1%		
Nominal voltage:	U _n V DC 24 V ± 10%		
Residual ripple:	10%		

¹) p¹ > p² + 10% p²
²) at p¹ - 10 bar to p² - 6.3 bar
[†] Inlet pressure 91.4 psig (6.3 bar) inlet pressure and 7.3 psig (0.5 bar) pressure drop.

Ordering Information:

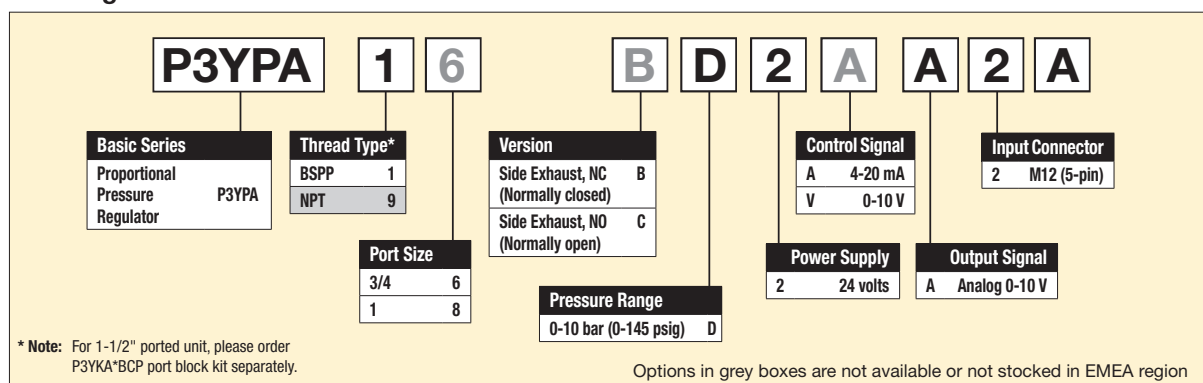

Most popular.



Material Specifications

Housing	Aluminium
Pilot valve booster	Brass / NBR composite aluminium
Standard seals	NBR
Body cover screws	Steel / zinc plated

Cables

Type	Part Number
M12, 5-pin female to flying lead cable, TPE; 2m (6.6 ft)	RKC 4.5T-2/S1587

Connection Diagram

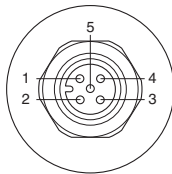

Connector M12 x 1

Pin No.	Function
1 24 V	Supply
2 0 V	Reference & mass capacity
3 0 - 10 V	Set value input
4 0 V	Signal
5 0 - 10 V	Analog output

Flow Characteristics

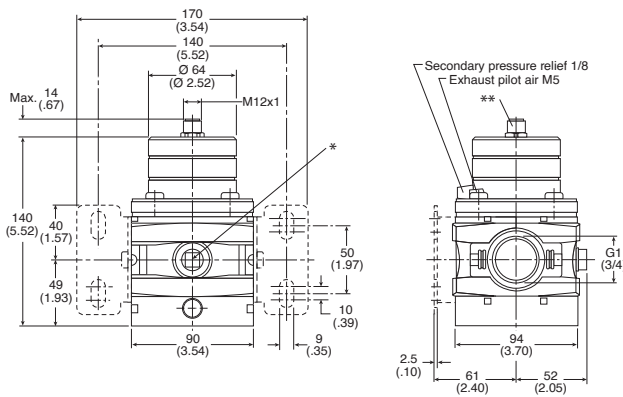
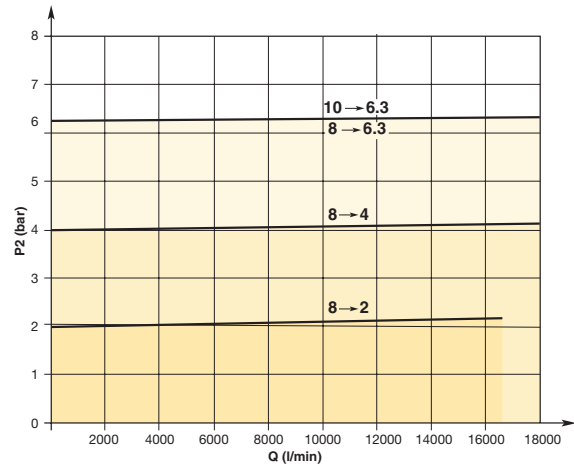

* Two opposite gauge ports 1/4, plug screw mounted
 ** Connection for 5-pin plug M12 x 1

P3Y Filter / Regulator - Large

- Integral 3/4" or 1" ports (BSPP or NPT)
- High efficiency element as standard
- Excellent water removal efficiency
- Robust but lightweight aluminium construction
- Secondary pressure ranges 12 and 16 bar
- Rolling diaphragm for extended life
- Secondary aspiration plus balanced poppet provides quick response and accurate pressure regulation.
- Reverse flow / relieving option
- Low temperature -40°C (-40°F) with combined manual / semi-auto drain as standard

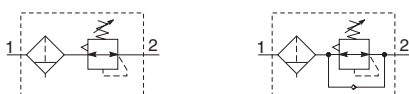

Port Size	Description (0 to 174 psi)	Part Number
3/4"	Relieving, COmbined Manual / Semi-Auto Drain	P3YEA16ESCBNEN
3/4"	Relieving, Auto Drain	P3YEA16ESABNEN
3/4"	Relieving, Gauge, COmbined Manual / Semi-Auto Drain	P3YEA16ESCBNFN
3/4"	Relieving, Gauge, Auto Drain	P3YEA16ESABNFN
1"	Relieving, COmbined Manual / Semi-Auto Drain	P3YEA18ESCBNEN
1"	Relieving, Auto Drain	P3YEA18ESABNEN
1"	Relieving, Gauge, COmbined Manual / Semi-Auto Drain	P3YEA18ESCBNFN
1"	Relieving, Gauge, Auto Drain	P3YEA18ESABNFN

Operating Information

Supply pressure (max)*:	254 psig (17.5 bar)
Operating temperature:	14°F to 140°F (-10°C to 60°C)
Auto drain	-40°F to 140°F (-40°C to 60°C)
Combined drain	
Standard filtration:	5 micron
Manual / semi-auto drain:	Closed at 11.6 psig (0.8 bar) G1/8 thread male
Auto drain bowl pressure:	Closed at 11.6 psig (0.8 bar)
Bowl capacity:	4.4 US oz. (130 cm ³)
Standard filtration:	5 micron
Flow capacity†:	3/4" 335 scfm (158.1 dm ³ /s, ANR) 1" 465 scfm (219.5 dm ³ /s, ANR)
Fluid:	Compressed air
Gauge port (x2):	1/4"
Weight:	3.3 lb (1.5 kg)
† Inlet pressure 91.4 psig (6.3 bar) inlet pressure and 7.3 psig (0.5 bar) pressure drop.	
* Air supply must be dry enough to avoid ice formation at temperatures below 35.6°F (2°C).	

Air quality: Within ISO 8573-1: 2010 Class 6 and 7 (Particulates)

Ordering Information:

Basic Series		Thread Type*		Drain Type		Relief		Lockable		Adjustment Range	
P3YEA	1	6	E SA	B	N	E	N	E	N		
Filter / Regulator P3YEA	BSPP 1		SC Combined Manual / Semi-Auto Drain	B Relieving	N Standard	E 0 to 174 psi (0 to 12 bar), No Gauge					
	NPT 9		SA Auto Drain	R Reverse Flow / Relieving	A† Lockable	H 0 to 232 psi (0 to 16 bar), No Gauge					
		Port Size				F 0 to 174 psi (0 to 12 bar), Gauge					
		3/4 6	Element			J 0 to 232 psi (0 to 16 bar), Gauge					
		1 8	E 5 micron								
			G 30 micron								

Notes:
* For 1-1/2" ported unit, please order P3YKA*BCP port block kit separately.
† Not field convertible.

Options in grey boxes are not available or not stocked in EMEA region

Material Specifications

Body	Aluminium
Sight glass and bowl	Polypropylene
Body cover	ABS
Element	Sintered polypropylene
Seals	Nitrile NBR
Manual / semi-auto drain	Acetal
Auto drain	PA / Ø 10mm brass connection
Bonnet	Glass filled polyamide
Control Knob	Glass filled polyamide
Valve	Brass / NBR
Screws	Steel / zinc plated

Repair and Service Kits

5 micron element kit	P3YKA00ESE
30 micron element kit	P3YKA00ESG
Bowl kit with combined manual/semi auto drain	P3YKA00BSC
Bowl kit with auto drain	P3YKA00BSA
Key lock kit	P3XKA00AS
Diaphragm kit (relieving type)	P3YKA00RR
Diaphragm kit (non-relieving type)	P3YKA00RN
Angle bracket + metal lock ring	P3YKA00MS
Panel mount nut	P3YKA00MM
0 to 300 psig (0 to 20 bar), gauge 1/4" port	P6G-ERB2200

Flow Characteristics

(3/4") 5 Micron Filter / Regulator

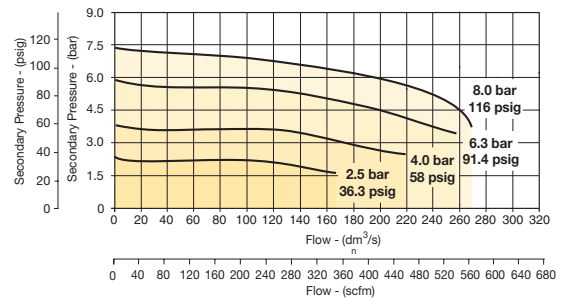

(1") 5 Micron Filter / Regulator

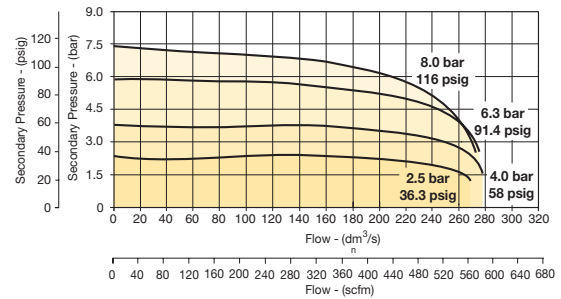

⚠ WARNING
Product rupture can cause serious injury.
Do not connect regulator to bottled gas.
Do not exceed Maximum primary pressure rating.

CAUTION:

REGULATOR PRESSURE ADJUSTMENT – The working range of knob adjustment is designed to permit outlet pressures within their full range. Pressure adjustment beyond this range is also possible because the knob is not a limiting device. This is a common characteristic of most industrial regulators, and limiting devices may be obtained only by special design. For best performance, regulated pressure should always be set by increasing the pressure up to the desired setting.

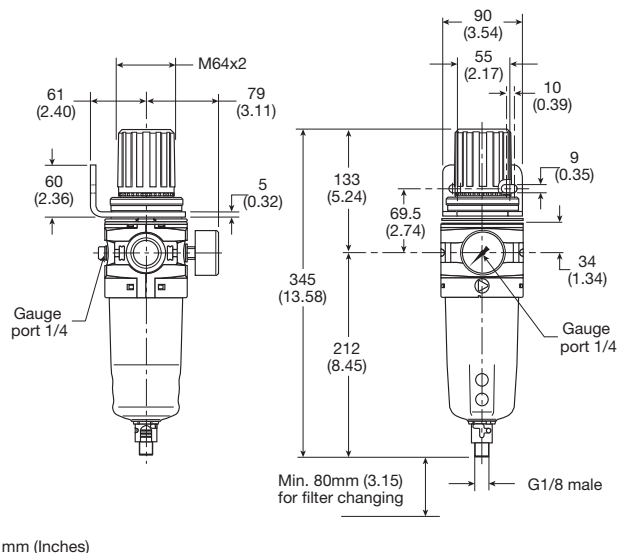

P3Y Lubricator - Large

- Integral 3/4" or 1" ports (BSPP and NPT)
- Robust but lightweight aluminium construction
- Proportional oil delivery over a wide range of air flows
- Possible to fill under system pressure eliminating down time
- Large oil reservoir

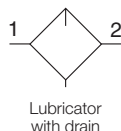

Port Size	Description	Part Number
3/4"	Oil Mist, Fill Under Pressure	P3YLA16LSNN
1"	Oil Mist, Fill Under Pressure	P3YLA18LSNN

Operating Information

Supply pressure (max)*:	254 psig (17.5 bar)
Operating temperature*:	14°F to 140°F (-10°C to 60°C)
Flow capacity†:	3/4" 315 scfm (148.2 dm³/s, ANR) 1" 390 scfm (184.1 dm³/s, ANR)
Fluid:	Compressed air
Weight:	1.8 lb (0.8 kg)

† Inlet pressure 91.4 psig (6.3 bar) inlet pressure and 7.3 psig (0.5 bar) pressure drop.

* Air supply must be dry enough to avoid ice formation at temperatures below 35.6°F (2°C).

Low flow start point (lubrication pick-up): at 6.3 bar (91.4 psig) inlet pressure 0.5 dm³/s (1.1 scfm).

Ordering Information:

P3YLA		1	6	LSNN
Basic Series		Thread Type*	Port Size	
Lubricator	P3YLA	BSPP 1 NPT 9	3/4 6 1 8	

* Note: For 1-1/2" ported unit, please order P3YKA*BCP port block kit separately. Options in grey boxes are not available or not stocked in EMEA region

Most popular.



Material Specifications

Body	Aluminium
Sight glass and bowl	Polypropylene
Sight dome	Polyamide
Lubricator cover	ABS
Top & bottom end cap	Glass filled nylon
Bayonet support	Nylon
Seals	Nitrile NBR

Repair and Service Kits

Bowl kit	P3YKA00BSN
Refill plug	P3YKA00PL
Lubricator Oil VG32 - 1 litre 0,92 kg	P3YKA00PPBB

Flow Characteristics

(3/4") Lubricator

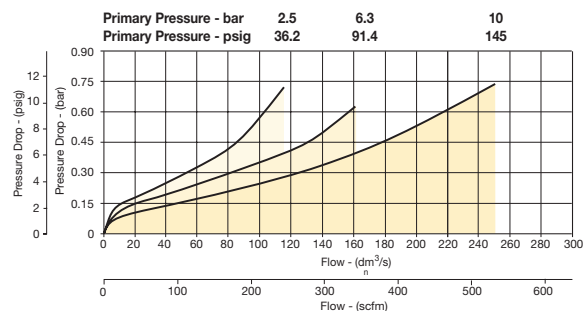

(1") Lubricator

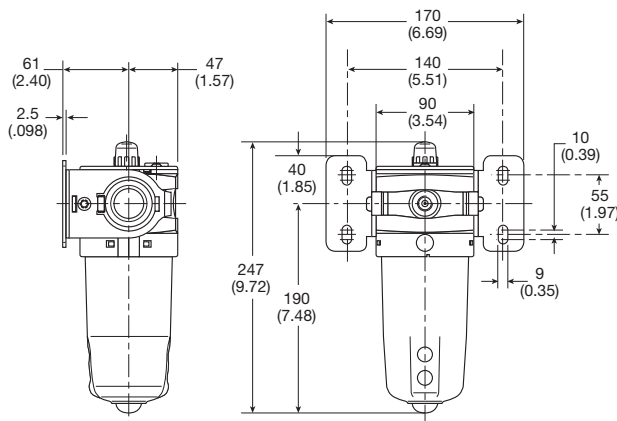
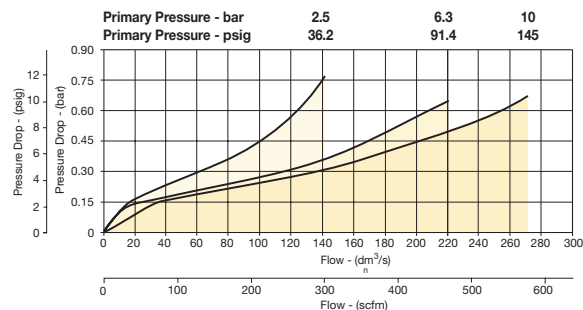

mm (Inches)

P3Y Combinations - Large



Filter + Regulator + Lubricator Combinations 5 micron element, 12 bar (174 psig) regulator + gauge and wall mounting bracket

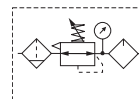

Port Size	Flow [‡] scfm	Weight lb (kg)	Combined Manual / Semi-Auto Drain [†]	Auto Drain [†]
3/4"	170	7.3 (3.3)	P3YCB16SECNFLNF	P3YCB16SEANFLNF
1"	170	7.3 (3.3)	P3YCB18SECNFLNF	P3YCB18SEANFLNF

† Standard part numbers shown in bold. For other models refer to Options chart below.

‡ Flow with 10 bar (145 psig) inlet pressure, 6.3 bar (91.4 psig) set pressure and 1 bar (14.5 psig) pressure drop.



Filter / Regulator + Lubricator Combinations 5 micron element, 12 bar (174 psig) regulator + gauge and wall mounting bracket

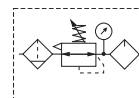

Port Size	Flow [‡] scfm	Weight lb (kg)	Combined Manual / Semi-Auto Drain [†]	Auto Drain [†]
3/4"	315	6.2 (2.8)	P3YCA16SECNFLNF	P3YCA16SEANFLNF
1"	340	6.2 (2.8)	P3YCA18SECNFLNF	P3YCA18SEANFLNF

† Standard part numbers shown in bold. For other models refer to Options chart below.

‡ Flow with 10 bar (145 psig) inlet pressure, 6.3 bar (91.4 psig) set pressure and 1 bar (14.5 psig) pressure drop.

Ordering Information:

P3YCA
1
6
SE
C
N
F
LNF

Basic Series	Thread Type*	Port Size	Element	Drain Type	Adjustment Range
Filter / Regulator + Lubricator P3YCA	BSPP 1	3/4 6	E 5 micron	C Combined Manual / Semi-Auto Drain	F 0-12 bar (0 to 174 psi) with Gauge
Filter + Regulator + Lubricator P3YCB	NPT 9	1 8	G 30 micron	A Auto Drain	J 0-16 bar (0 to 232 psi) with Gauge

* Note: For 1-1/2" ported unit, please order P3YKA*BCP port block kit separately. Options in grey boxes are not available or not stocked in EMEA region

⚠ WARNING

**Product rupture can cause serious injury.
Do not connect regulator to bottled gas.
Do not exceed Maximum primary pressure rating.**

CAUTION:
REGULATOR PRESSURE ADJUSTMENT -
The working range of knob adjustment is designed to permit outlet pressures within their full range. Pressure adjustment beyond this range is also possible because the knob is not a limiting device. This is a common characteristic of most industrial regulators, and limiting devices may be obtained only by special design. For best performance, regulated pressure should always be set by increasing the pressure up to the desired setting.



Popular Combination Dimensions mm (inches)

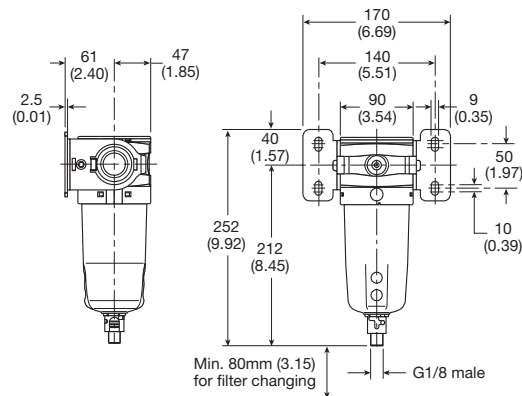
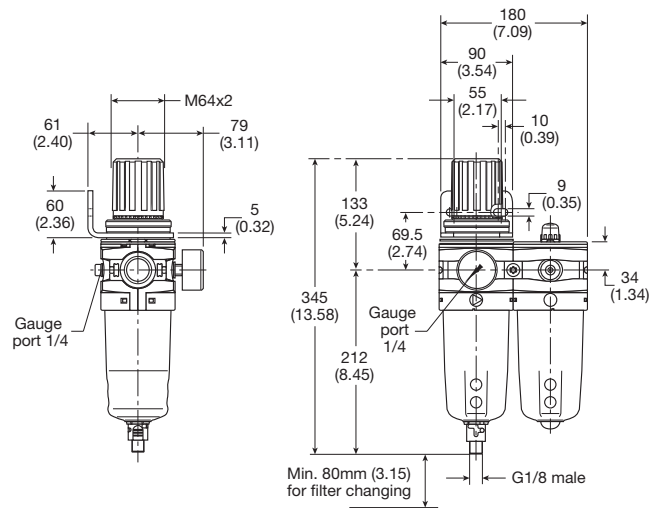
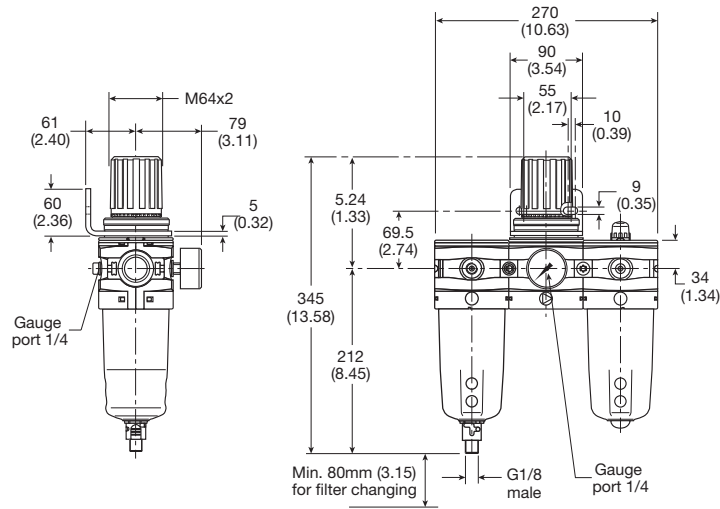

P3Y Combined Soft Start / Dump Valve - Large

- Modular design with 3/4" & 1" integral ports (BSPP or NPT)
- Provides for the safe introduction of pressure
- Automatically dumps downstream pressure on the loss of pilot signal
- Adjustable slow start
- Solenoid or air pilot options
- High flow & exhaust capability

P3Y Series Combined Soft Start / Dump Valves, provide for the safe introduction of pressure to machines or systems. Soft Start / Dump Valves when set, allow the pressure to gradually build to the set point before fully opening to deliver full flow at line pressure.

The controlled introduction of pressure can be an important safety factor and prevent damage to tooling when air pressure is introduced at machine or system start up.

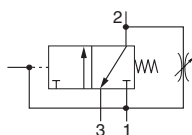

Port Size	Description	Part Number
3/4"	Air pilot operated	P3YTA16PPN
3/4"	24VDC 30mm coil	P3YTA16SCNA2CN
1"	Air pilot operated	P3YTA18PPN
1"	24VDC 30mm coil	P3YTA18SCNA2CN

Operating Information

Operating pressure (max):	30mm coil	232 psig (16 bar)
Operating pressure (min):		2.9 psig (0.2 bar)
Operating temperature*:	Solenoid operated	14°F to 140°F (-10°C to 60°C)
	Air pilot operated	14°F to 140°F (-10°C to 60°C)
Air pilot port:		1/8"
Exhaust port:	NPT	3/4"
	BSPP	1"
Gauge port:		1/4"
Flow capacity†:	3/4"	371 scfm (175.1 dm³/s, ANR)
	1"	424 scfm (200.1 dm³/s, ANR)
Fluid:		Compressed air
Weight:	Air pilot	3.1 lb (1.4 kg)
	30mm coil	3.5 lb (1.6 kg)

† Inlet pressure 91.4 psig (6.3 bar) inlet pressure and 7.3 psig (0.5 bar) pressure drop.

* Air supply must be dry enough to avoid ice formation at temperatures below 35.6°F (2°C).

Snap pressure: Full flow when downstream pressure reaches 50% of the inlet pressure.

Ordering Information:

P3YTA

Basic Series	
Soft Start / Dump Valve	P3YTA

1

Thread Type*	
BSPP	1
NPT	9

6

Port Size	
3/4	6
1	8

S C N

Pilot Type	
External Air Pilot	P
Solenoid Pilot	S

A 2 C N

Solenoid Voltage	
2CN	24VDC

Actuator Interface	
30mm Operator	C
Threaded Air Pilot	P

Solenoid Type	
A	30mm CNOMO Coil
D	30mm CNOMO Coil (M12 connection)

* Note: For 1-1/2" ported unit, please order P3YKA*BCP port block kit separately.

Options in grey boxes are not available or not stocked in EMEA region

Most popular.



Material Specifications

Body	Aluminium
Body cover	ABS
Valve	Brass / NBR composite
Pilot valve booster	Aluminium
Seals	Nitrile NBR

Note: For solenoid coil and cable plug options see solenoid operator pages.

Flow Characteristics

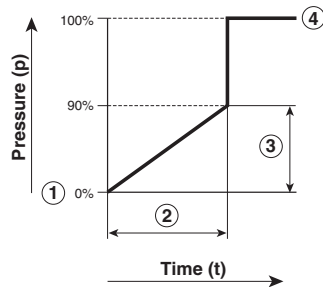

- ① Start signal
- ② Switching time delay
- ③ Gradual pressure build up
- ④ Operating pressure $p^2 (= p^1)$

Combined start / stop function

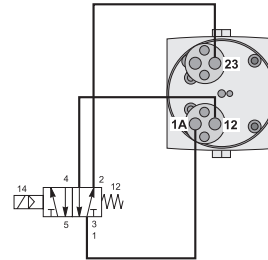

Combined start / stop function with acknowledgement

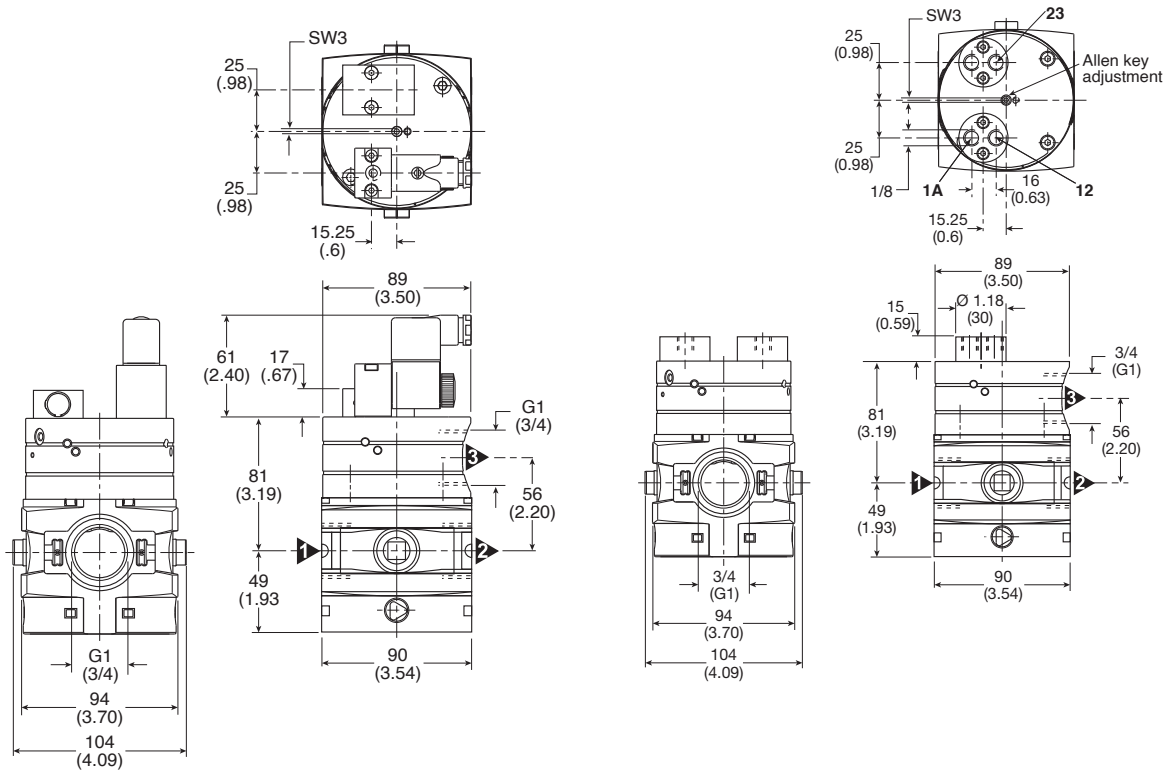
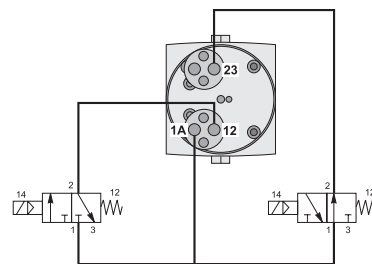

P3Y Soft Start Valve - Large

- Integral 3/4" or 1" ports
- Smooth start-up of pneumatic system
- Air pilot operation
- Adjustable slow start
- High flow

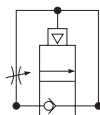

Port Size	Description	Part Number
3/4"	Soft Start Valve	P3YSA16Y0N
1"	Soft Start Valve	P3YSA18Y0N

Material Specifications

Body	Aluminium
Body cover	ABS
Valve	Brass / NBR composite
Pilot valve booster	Aluminium
Seals	Nitrile NBR

Operating Information

Operating pressure (max):	254 psig (17.5 bar)
Operating pressure (min):	29 psig (2 bar)
Operating temperature*:	
Solenoid operated	14°F to 140°F (-10°C to 60°C)
Air pilot operated	14°F to 140°F (-10°C to 60°C)
Flow capacity†:	
3/4"	324 scfm (152.9 dm³/s, ANR)
1"	324 scfm (152.9 dm³/s, ANR)
Fluid:	Compressed air
Weight:	1.8 lb (0.8 kg)

† Inlet pressure 91.4 psig (6.3 bar) inlet pressure and 7.3 psig (0.5 bar) pressure drop.

* Air supply must be dry enough to avoid ice formation at temperatures below 35.6°F (2°C).

Snap pressure: Full flow when downstream pressure reaches 50% of the inlet pressure.

Ordering Information:

P3YSA
1
6
Y
0
N

Basic Series		Thread Type*		Port Size	
Soft Start Valve	P3YSA	BSPP	1	3/4	6
		NPT	9	1	8

* Note: For 1-1/2" ported unit, please order P3YKA*BCP port block kit separately.

Options in grey boxes are not available or not stocked in EMEA region

Flow Characteristics

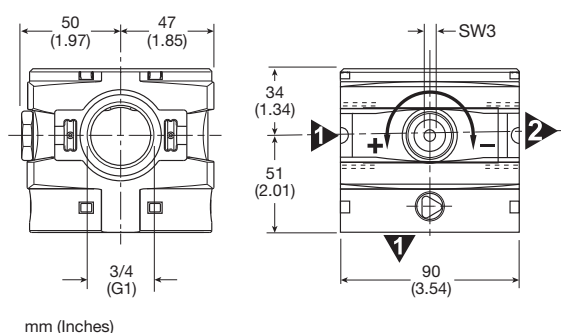
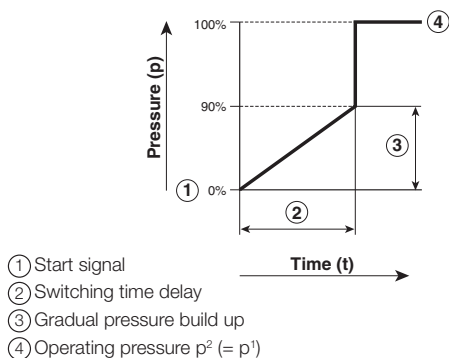

 Most popular.



P3Y Modular Ball Valve - Large

- Positive bubble tight shut-off
- 90° turn handle to prevent unauthorized adjustment
- Pad lockable (up to 6 times)
- When the inlet pressure is turned off the downstream vents through the exhaust port

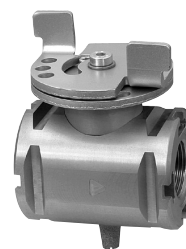
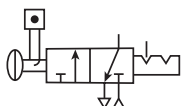

Ball / Lockout Valve shuts off downstream line pressure in the closed position with a 90° turn of the handle. In the closed position, inlet air pressure is blocked and downstream / system air is exhausted through a threaded port. To prevent unauthorized adjustment, the padlock slide may be assembled on either side. It is recommended that this slide is installed after final system assembly.

The Safety Lockout valves conform to OSHA #29 CFR part 1910 – control of hazardous energy source (lockout / tagout).

Operating Information

Operating pressure (max):	254 psig (17.5 bar)
Operating pressure (min):	29 psig (2 bar)
Operating temperature:	14°F to 140°F (-10°C to 60°C)
Flow capacity*:	3/4" 705.6 scfm (333 dm ³ /s, ANR)
	1" 705.6 scfm (333 dm ³ /s, ANR)
Weight:	3/4" 2.4 lb (1.1 kg)
	1" 2.4 lb (1.1 kg)

Ordering Information:

P3YVA		1	6	LBN
Basic Series	Thread Type*	Port Size		
Modular Ball Valve P3YVA	BSPP 1	3/4 6		
	NPT 9	1 8		

* Note: For 1-1/2" ported unit, please order P3YKA*BCP port block kit separately.

Options in grey boxes are not available or not stocked in EMEA region

Material Specifications

Body	Aluminium
Valve ball	Brass / nickle plated
Handle	Aluminium
Seals	Nitrile NBR
Exhaust silencer	Sintered bronze

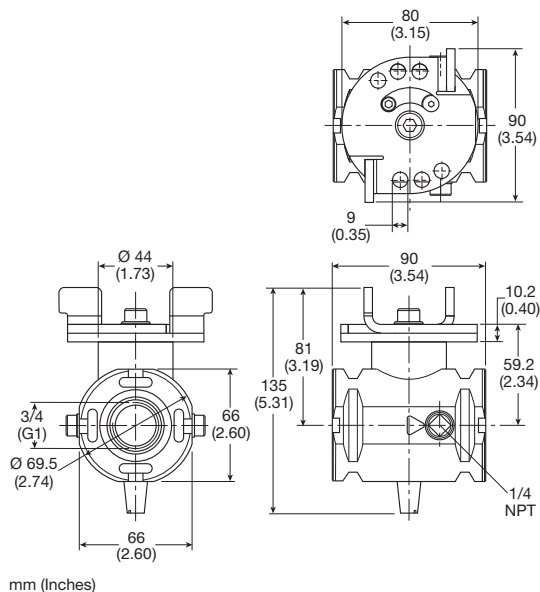

PDE2676TCUK

Global FRL and P3Y Series

P3Y Series Accessories

Modular Manifold



P3Y Series Manifolds provide up to 4 extra outlet ports. They may be assembled at any position in a combination e.g. before the lubricator to provide oil free take off or at the end of a combination to provide extra outlet ports.

Thread Type	Part Number
BSPP	P3YMA1V0N
NPT	P3YMA9V0N

Port sizes

Inlet Port	Top	Bottom	Front and Back
3/4"	1/8"	1"	1/4"
1"	1/8"	1"	1/4"

Material Specifications

Body	Aluminium
Weight	0.7 kg (1.5 lb)

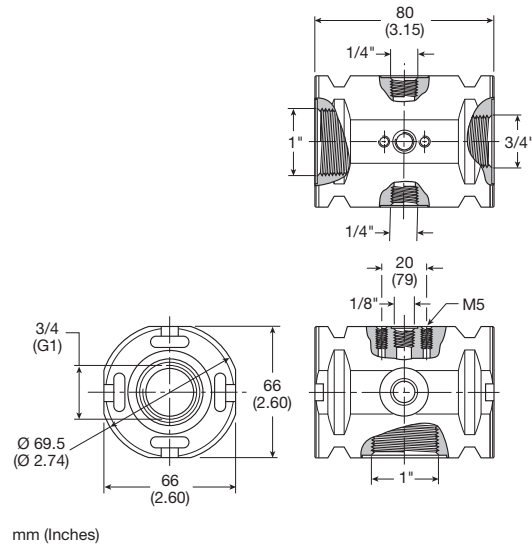

Optional Port Block Kits

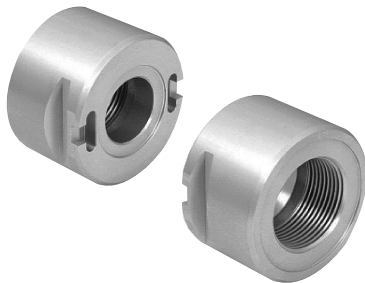

- To change port sizes Port Block Kits are available, they are attached to any unit utilizing the connecting kit.
- Allows assemblies to be removed from a hard piped system.

Material Specifications

Body	Aluminium
Weight	0.65 kg (1.43 lb)

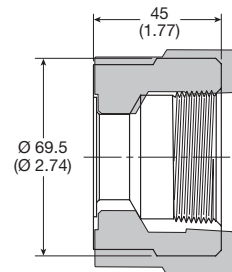

Inches (mm)

Ordering Information:

P3YKA		1	B	CP
Basic Series	Port Blocks	Thread Type	Port Size	
P3YKA		BSPP	1-1/4 A	
		NPT	1-1/2 B	



Solenoid Operators - CNOMO

**Technical Data -
Solenoid operators, coil combinations**

	NC Normal Operator with 22 x 30 standard coil	NC Normal Operator with 30 x 30 standard coil
Working pressure	0 to 10 bar	0 to 10 bar
Ambient temperature	-10°C to 60°C *	-10°C to 60°C *
Power (DC)	4.8W	2.7W
Power (AC)	8.5VA	4.9VA
Voltage tolerance	+/-10%	+/-10%
Duty cycle	100%	100%
Insulation class	F	F
Electric connection	B Industrial	DIN 43650A
Protection	IP65	IP65
Approval		UL/CSA
Working media	All neutral media such as compressed air	

* Limited to 50°C if use with 100% duty cycle

Solenoid Coils with M12 Connection

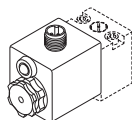

Voltage	Part Number	Weight (Kg)
Direct current		
24VDC	P2FC6449	0.065

Transients

Interrupting the current through the solenoid coil produces momentary voltage peaks which, under unfavorable conditions, can amount to several hundred times the rated operating voltage. Normally, these transients do not cause problems, but to achieve the Maximum life of relays in the circuit (and particularly of transistors, thyristors and integrated circuits) it is desirable to provide protection by means of voltage-dependent resistors (varistors). All connectors/cable plugs EN175301-803 with LED's include this type of circuit protection.

Materials

Pilot Valve

Body:	Polyamide
Armature tube:	Brass
Plunger & core:	Corrosion resistant Cr-Ni steel
Seals:	Fluorocarbon
Screws:	Stainless steel

Coil

Encapsulation material:	Thermoplastic as standard Duroplast for M12 connection
-------------------------	-----------------------------------------------------------

Solenoid Coils with DIN A or Industrial B Connection

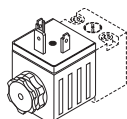

Voltage	22mm x 30mm Part Number B Industrial Standard	Weight (Kg)	30mm x 30mm Part Number DIN 43650A Standard	Weight (Kg)
Direct current				
24VDC	P2FCB449	0.093	P2FCA449	0.105
Alternative current				
110V 50Hz, 120V 60Hz	P2FCB453	0.093	P2FCA453	0.105

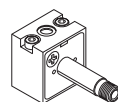

**Spare Base Solenoid Pilot Operator
CNOMO NC**



Description	Part Number	Weight (Kg)
Non-lock Manual Override	P2FP23N4B	0.065
No Override	P2FP23N4A	0.065

Note: Solenoid pilot operators are fitted to the Global range. Order the above part numbers for spares. The operators are supplied with mounting screws and interface 'O' rings. Coils and connectors must be ordered separately.

Solenoid Connectors / Cable Plugs EN175301-803

	Description	Part Number 22mm Form B Industrial	Part Number 30mm Form A DIN 43650A
 With standard screw	Standard IP65 without flying lead	3EV10V10	3EV290V10
	With LED and protection 24VAC/DC	3EV10V20-24	3EV290V20-24
	With LED and protection 110VAC	3EV10V20-110	3EV290V20-110
	With LED and protection 230VAC	3EV10V20-230	3EV290V20-230
 With cable	Standard with 5m cable IP65	-	-
	24VAC/DC, 5m cable LED and protection IP65	3EV10V20-24L5	3EV290V20-24L5
	110VAC/DC, 5m cable LED and protection IP65	3EV10V20-110L5	3EV290V20-110L5
	230VAC/DC, 5m cable LED and protection IP65	3EV10V20-230L5	3EV290V20-230L5

Solenoid Coil Dimensions mm (inches)

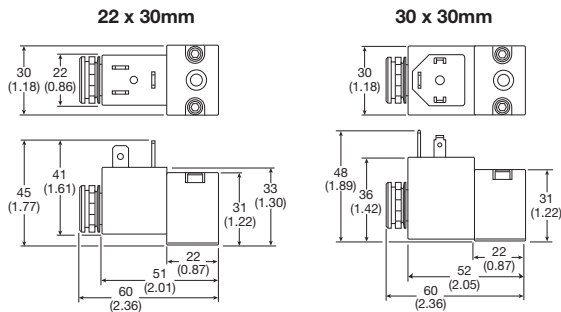

Electrical Schematics

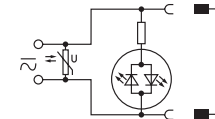

3EV10V20-24	3EV290V20-24
3EV10V20-110	3EV290V20-110
3EV10V20-230	3EV290V20-230
-	-
-	-
-	-

Cable Plug Dimensions mm (inches)

22mm Form B industrial cable plugs

3EV10V10

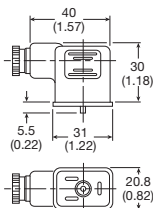





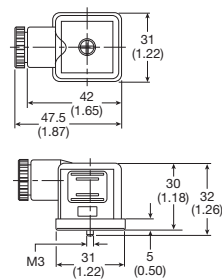



30mm Form A cable plugs

3EV290V10



PDE2676TCUK
Global FRL and P3Y Series

**P3Y Series
 Accessories**

Description	Connection	Weight lb (kg)	Part Number	
0.01 micron Element Kit			P3YKA00ESC	
1 micron Element Kit			P3YKA00ES9	
5 micron Element Kit			P3YKA00ESE	
30 micron Element Kit			P3YKA00ESG	
Adsorber Element Kit			P3YKA00ESA	
Angle Bracket + Metal Lock Ring			P3YKA00MS	
Bowl Kit With Combined Manual / Semi-Auto Drain			P3YKA00BSC	
Bowl Kit With Auto Drain			P3YKA00BSA	
Bowl Kit			P3YKA00BSN	
Connector O-Ring Kit	Qty: 5		P3YKA08CY	
Differential Pressure Indicator Kit			P3YKA00RQ	
Diaphragm Kit (Relieving Type)			P3YKA00RR	
Diaphragm Kit (Non-Relieving Type)			P3YKA00RN	
Key Lock (Replacement)			P3XKA00AS	
Lubricator Oil	VG32 - 1 litre	2.03 (0.92)	P3YKA00PPBB	
Neck Mounting Bracket Kit		8.27 (3.75)	P3YKA00MS	
P3y Connecting Kit		0.11 (0.05)	P3YKA00CB	
Panel Mounting Nut (Aluminium)		1.54 (0.70)	P3YKA00MM	
Pressure Gauge	0 to 300 psig 0 to 20 bar	1/4"	P6G-ERB2200	
Refill Plug			P3YKA00PL	
Wall Mounting Brackets		0.44 (0.2)	P3YKA00CW	

Options in grey are not available or not stocked in EMEA region

Safety Guide For Selecting And Using Pneumatic Division Products And Related Accessories

WARNING:

FAILURE OR IMPROPER SELECTION OR IMPROPER USE OF PNEUMATIC DIVISION PRODUCTS, ASSEMBLIES OR RELATED ITEMS (“PRODUCTS”) CAN CAUSE DEATH, PERSONAL INJURY, AND PROPERTY DAMAGE. POSSIBLE CONSEQUENCES OF FAILURE OR IMPROPER SELECTION OR IMPROPER USE OF THESE PRODUCTS INCLUDE BUT ARE NOT LIMITED TO:

- Unintended or mistimed cycling or motion of machine members or failure to cycle
- Work pieces or component parts being thrown off at high speeds.
- Failure of a device to function properly for example, failure to clamp or unclamp an associated item or device.
- Explosion
- Suddenly moving or falling objects.
- Release of toxic or otherwise injurious liquids or gasses.

Before selecting or using any of these Products, it is important that you read and follow the instructions below.

1. GENERAL INSTRUCTIONS

- 1.1. Scope: This safety guide is designed to cover general guidelines on the installation, use, and maintenance of Pneumatic Division Valves, FRLs (Filters, Pressure Regulators, and Lubricators), Vacuum products and related accessory components.
- 1.2. Fail-Safe: Valves, FRLs, Vacuum products and their related components can and do fail without warning for many reasons. Design all systems and equipment in a fail-safe mode, so that failure of associated valves, FRLs or Vacuum products will not endanger persons or property.
- 1.3. Relevant International Standards: For a good guide to the application of a broad spectrum of pneumatic fluid power devices see: ISO 4414:1998, Pneumatic Fluid Power – General Rules Relating to Systems. See www.iso.org for ordering information.
- 1.4. Distribution: Provide a copy of this safety guide to each person that is responsible for selection, installation, or use of Valves, FRLs or Vacuum products. Do not select, or use Parker valves, FRLs or vacuum products without thoroughly reading and understanding this safety guide as well as the specific Parker publications for the products considered or selected.
- 1.5. User Responsibility: Due to the wide variety of operating conditions and applications for valves, FRLs, and vacuum products Parker and its distributors do not represent or warrant that any particular valve, FRL or vacuum product is suitable for any specific end use system. This safety guide does not analyze all technical parameters that must be considered in selecting a product. The user, through its own analysis and testing, is solely responsible for:
 - Making the final selection of the appropriate valve, FRL, Vacuum component, or accessory.
 - Assuring that all user’s performance, endurance, maintenance, safety, and warning requirements are met and that the application presents no health or safety hazards.
 - Complying with all existing warning labels and / or providing all appropriate health and safety warnings on the equipment on which the valves, FRLs or Vacuum products are used; and,
 - Assuring compliance with all applicable government and industry standards.
- 1.6. Safety Devices: Safety devices should not be removed, or defeated.
- 1.7. Warning Labels: Warning labels should not be removed, painted over or otherwise obscured.
- 1.8. Additional Questions: Call the appropriate Parker technical service department if you have any questions or require any additional information. See the Parker publication for the product being considered or used, or call 1-800-CPARKER, or go to www.parker.com, for telephone numbers of the appropriate technical service department.

2. PRODUCT SELECTION INSTRUCTIONS

- 2.1. Flow Rate: The flow rate requirements of a system are frequently the primary consideration when designing any pneumatic system. System components need to be able to provide adequate flow and pressure for the desired application.
- 2.2. Pressure Rating: Never exceed the rated pressure of a product. Consult product labeling, Pneumatic Division catalogs or the instruction sheets supplied for Maximum pressure ratings.
- 2.3. Temperature Rating: Never exceed the temperature rating of a product. Excessive heat can shorten the life expectancy of a product and result in complete product failure.
- 2.4. Environment: Many environmental conditions can affect the integrity and suitability of a product for a given application. Pneumatic Division products are designed for use in general purpose industrial applications. If these products are to be used in unusual circumstances such as direct sunlight and/or corrosive or caustic environments, such use can shorten the useful life and lead to premature failure of a product.
- 2.5. Lubrication and Compressor Carryover: Some modern synthetic oils can and will attack nitrile seals. If there is any possibility of synthetic oils or greases migrating into the pneumatic components check for compatibility with the seal materials used. Consult the factory or product literature for materials of construction.
- 2.6. Polycarbonate Bowls and Sight Gauges: To avoid potential polycarbonate bowl failures:
 - Do not locate polycarbonate bowls or sight gauges in areas where they could be subject to direct sunlight, impact blow, or temperatures outside of the rated range.
 - Do not expose or clean polycarbonate bowls with detergents, chlorinated hydro-carbons, ketones, esters or certain alcohols.
 - Do not use polycarbonate bowls or sight gauges in air systems where compressors are lubricated with fire resistant fluids such as phosphate ester and di-ester lubricants.

- 2.7. Chemical Compatibility: For more information on plastic component chemical compatibility see Pneumatic Division technical bulletins Tec-3, Tec-4, and Tec-5
- 2.8. Product Rupture: Product rupture can cause death, serious personal injury, and property damage.
 - Do not connect pressure regulators or other Pneumatic Division products to bottled gas cylinders.
 - Do not exceed the Maximum primary pressure rating of any pressure regulator or any system component.
 - Consult product labeling or product literature for pressure rating limitations.
3. PRODUCT ASSEMBLY AND INSTALLATION INSTRUCTIONS
 - 3.1. Component Inspection: Prior to assembly or installation a careful examination of the valves, FRLs or vacuum products must be performed. All components must be checked for correct style, size, and catalog number. DO NOT use any component that displays any signs of nonconformance.
 - 3.2. Installation Instructions: Parker published Installation Instructions must be followed for installation of Parker valves, FRLs and vacuum components. These instructions are provided with every Parker valve or FRL sold, or by calling 1-800-CPARKER, or at www.parker.com.
 - 3.3. Air Supply: The air supply or control medium supplied to Valves, FRLs and Vacuum components must be moisture-free if ambient temperature can drop below freezing
4. VALVE AND FRL MAINTENANCE AND REPLACEMENT INSTRUCTIONS
 - 4.1. Maintenance: Even with proper selection and installation, valve, FRL and vacuum products service life may be significantly reduced without a continuing maintenance program. The severity of the application, risk potential from a component failure, and experience with any known failures in the application or in similar applications should determine the frequency of inspections and the servicing or replacement of Pneumatic Division products so that products are replaced before any failure occurs. A maintenance program must be established and followed by the user and, at Minimum, must include instructions 4.2 through 4.10.
 - 4.2. Installation and Service Instructions: Before attempting to service or replace any worn or damaged parts consult the appropriate Service Bulletin for the valve or FRL in question for the appropriate practices to service the unit in question. These Service and Installation Instructions are provided with every Parker valve and FRL sold, or are available by calling 1-800-CPARKER, or by accessing the Parker web site at www.parker.com.
 - 4.3. Lockout / Tagout Procedures: Be sure to follow all required lockout and tagout procedures when servicing equipment. For more information see: OSHA Standard – 29 CFR, Part 1910.147, Appendix A, The Control of Hazardous Energy – (Lockout / Tagout)
 - 4.4. Visual Inspection: Any of the following conditions requires immediate system shut down and replacement of worn or damaged components:
 - Air leakage: Look and listen to see if there are any signs of visual damage to any of the components in the system. Leakage is an indication of worn or damaged components.
 - Damaged or degraded components: Look to see if there are any visible signs of wear or component degradation.
 - Kinked, crushed, or damaged hoses. Kinked hoses can result in restricted air flow and lead to unpredictable system behavior.
 - Any observed improper system or component function: Immediately shut down the system and correct malfunction.
 - Excessive dirt build-up: Dirt and clutter can mask potentially hazardous situations.Caution: Leak detection solutions should be rinsed off after use.
 - 4.5. Routine Maintenance Issues:
 - Remove excessive dirt, grime and clutter from work areas.
 - Make sure all required guards and shields are in place.
 - 4.6. Functional Test: Before initiating automatic operation, operate the system manually to make sure all required functions operate properly and safely.
 - 4.7. Service or Replacement Intervals: It is the user's responsibility to establish appropriate service intervals. Valves, FRLs and vacuum products contain components that age, harden, wear, and otherwise deteriorate over time. Environmental conditions can significantly accelerate this process. Valves, FRLs and vacuum components need to be serviced or replaced on routine intervals. Service intervals need to be established based on:
 - Previous performance experiences.
 - Government and / or industrial standards.
 - When failures could result in unacceptable down time, equipment damage or personal injury risk.
 - 4.8. Servicing or Replacing of any Worn or Damaged Parts: To avoid unpredictable system behavior that can cause death, personal injury and property damage:
 - Follow all government, state and local safety and servicing practices prior to service including but not limited to all OSHA Lockout Tagout procedures (OSHA Standard – 29 CFR, Part 1910.147, Appendix A, The Control of Hazardous Energy – Lockout / Tagout).
 - Disconnect electrical supply (when necessary) before installation, servicing, or conversion.
 - Disconnect air supply and depressurize all air lines connected to system and Pneumatic Division products before installation, service, or conversion.
 - Installation, servicing, and / or conversion of these products must be performed by knowledgeable personnel who understand how pneumatic products are to be applied.
 - After installation, servicing, or conversions air and electrical supplies (when necessary) should be connected and the product tested for proper function and leakage. If audible leakage is present, or if the product does not operate properly, do not put product or system into use.
 - Warnings and specifications on the product should not be covered or painted over. If masking is not possible, contact your local representative for replacement labels.
 - 4.9. Putting Serviced System Back into Operation: Follow the guidelines above and all relevant Installation and Maintenance Instructions supplied with the valve FRL or vacuum component to insure proper function of the system.

Parker Worldwide

Europe, Middle East, Africa

AE – United Arab Emirates, Dubai
Tel: +971 4 8127100
parker.me@parker.com

AT – Austria, Wiener Neustadt
Tel: +43 (0)2622 23501-0
parker.austria@parker.com

AT – Eastern Europe, Wiener Neustadt
Tel: +43 (0)2622 23501 900
parker.easteurope@parker.com

AZ – Azerbaijan, Baku
Tel: +994 50 2233 458
parker.azerbaijan@parker.com

BE/LU – Belgium, Nivelles
Tel: +32 (0)67 280 900
parker.belgium@parker.com

BG – Bulgaria, Sofia
Tel: +359 2 980 1344
parker.bulgaria@parker.com

BY – Belarus, Minsk
Tel: +375 17 209 9399
parker.belarus@parker.com

CH – Switzerland, Etoy
Tel: +41 (0)21 821 87 00
parker.switzerland@parker.com

CZ – Czech Republic, Klecany
Tel: +420 284 083 111
parker.czechrepublic@parker.com

DE – Germany, Kaarst
Tel: +49 (0)2131 4016 0
parker.germany@parker.com

DK – Denmark, Ballerup
Tel: +45 43 56 04 00
parker.denmark@parker.com

ES – Spain, Madrid
Tel: +34 902 330 001
parker.spain@parker.com

FI – Finland, Vantaa
Tel: +358 (0)20 753 2500
parker.finland@parker.com

FR – France, Contamine s/Arve
Tel: +33 (0)4 50 25 80 25
parker.france@parker.com

GR – Greece, Athens
Tel: +30 210 933 6450
parker.greece@parker.com

HU – Hungary, Budaörs
Tel: +36 23 885 470
parker.hungary@parker.com

IE – Ireland, Dublin
Tel: +353 (0)1 466 6370
parker.ireland@parker.com

IT – Italy, Corsico (MI)
Tel: +39 02 45 19 21
parker.italy@parker.com

KZ – Kazakhstan, Almaty
Tel: +7 7273 561 000
parker.easteurope@parker.com

NL – The Netherlands, Oldenzaal
Tel: +31 (0)541 585 000
parker.nl@parker.com

NO – Norway, Asker
Tel: +47 66 75 34 00
parker.norway@parker.com

PL – Poland, Warsaw
Tel: +48 (0)22 573 24 00
parker.poland@parker.com

PT – Portugal, Leca da Palmeira
Tel: +351 22 999 7360
parker.portugal@parker.com

RO – Romania, Bucharest
Tel: +40 21 252 1382
parker.romania@parker.com

RU – Russia, Moscow
Tel: +7 495 645-2156
parker.russia@parker.com

SE – Sweden, Spånga
Tel: +46 (0)8 59 79 50 00
parker.sweden@parker.com

SL – Slovenia, Novo Mesto
Tel: +386 7 337 6650
parker.slovenia@parker.com

TR – Turkey, Istanbul
Tel: +90 216 4997081
parker.turkey@parker.com

UA – Ukraine, Kiev
Tel: +380 44 494 2731
parker.poland@parker.com

UK – United Kingdom, Warwick
Tel: +44 (0)1926 317 878
parker.uk@parker.com

ZA – South Africa, Kempton Park
Tel: +27 (0)11 961 0700
parker.southafrica@parker.com

North America

CA – Canada, Milton, Ontario
Tel: +1 905 693 3000

US – USA, Cleveland
Tel: +1 216 896 3000

Asia Pacific

AU – Australia, Castle Hill
Tel: +61 (0)2-9634 7777

CN – China, Shanghai
Tel: +86 21 2899 5000

HK – Hong Kong
Tel: +852 2428 8008

IN – India, Mumbai
Tel: +91 22 6513 7081-85

JP – Japan, Tokyo
Tel: +81 (0)3 6408 3901

KR – South Korea, Seoul
Tel: +82 2 559 0400

MY – Malaysia, Shah Alam
Tel: +60 3 7849 0800

NZ – New Zealand, Mt Wellington
Tel: +64 9 574 1744

SG – Singapore
Tel: +65 6887 6300

TH – Thailand, Bangkok
Tel: +662 186 7000

TW – Taiwan, Taipei
Tel: +886 2 2298 8987

South America

AR – Argentina, Buenos Aires
Tel: +54 3327 44 4129

BR – Brazil, Sao Jose dos Campos
Tel: +55 12 4009 3500

CL – Chile, Santiago
Tel: +562 2303 9640

MX – Mexico, Toluca
Tel: +52 72 2275 4200

European Product Information Centre

Free phone: 00 800 27 27 5374

(from AT, BE, CH, CZ, DE, DK, EE, ES, FI, FR, IE, IL, IS, IT, LU, MT, NL, NO, PL, PT, RU, SE, SK, UK, ZA)



Parker Hannifin Ltd.
Tachbrook Park Drive
Tachbrook Park,
Warwick, CV34 6TU
United Kingdom
Tel.: +44 (0) 1926 317 878
Fax: +44 (0) 1926 317 855
parker.uk@parker.com
www.parker.com