



## Modular Pneumatic Linear Drive Systems

ORIGA SYSTEM PLUS

aerospace  
climate control  
electromechanical  
filtration  
fluid & gas handling  
hydraulics  
pneumatics  
process control  
sealing & shielding



ENGINEERING YOUR SUCCESS.

Parker Origa rodless pneumatic cylinders are the first rodless cylinders that have been approved for use in potentially explosive atmospheres in Equipment Group II, Category 2 GD.

The Cylinders are to the ATEX Directive 2014/34/EU for Pneumatic Components.

For the different classifications and details please see pages 35, 36.

You will find further information on the ATEX Directives in our brochure PDE2584TCUK.

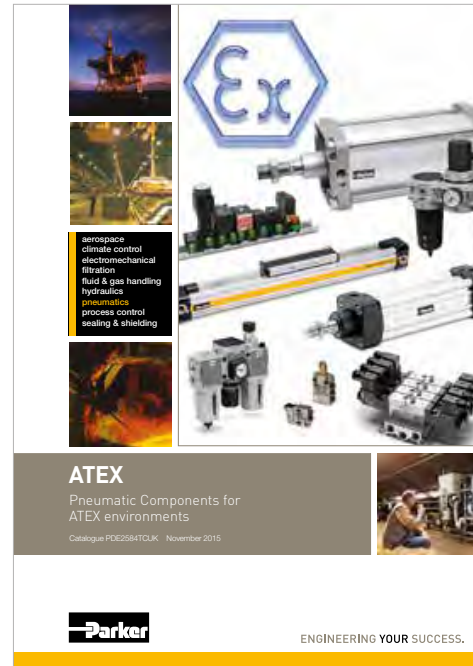

## Special Versions



for use in Ex-Areas



for Clean Room Applications certified to DIN EN ISO 14644-1



Stainless steel version for special applications



with special pneumatic cushioning system for cycle time optimisation, for Ø 16 to 50 mm – on request



High Temperature Version for temperatures up to +120°C



Low Temperature Version for temperatures down to -40°C



Slow Speed Version  $v = 0.005 - 0.2 \text{ m/s}$



High Speed Version  $v_{\text{max.}} = 30 \text{ m/s}$







Cylinders with extreme long strokes Stroke length up to 41 m

**Note:**  
For guidance on the application of the information in this catalogue please refer to the inner back cover.

# Contents Linear Drives



ORIGA System Plus - the concept		Page
	Introduction – OSP Concept	2-3
	Modular Components Overview	4-5
	Control Examples for OSP-P	6
	OSP-P Application examples	7
Rodless Pneumatic Cylinders		
	Overview	9-13
	Series OSP-P Ø10 to 80 mm	15-21, 24
	Integrated Valves V0E	22-23
	Long-Stroke Cylinders	25-29
	Clean Room Cylinders	31-34
	ATEX-Version 	35-36
<b>NEW</b>	ATEX-Version  BASIC GUIDE	35-36
	ATEX-Version  Plain Bearing Guide SLIDELINE	35-36
	Bi-parting Version	37-38
<b>NEW</b>	BASIC GUIDE BG	39-45
Linear Guides		
	Overview	47-48
	Plain Bearing Guide SLIDELINE	49-51
	Plain Bearing Guide SLIDELINE – with ACTIVE-Brake	49-51
	Roller Guide POWERSLIDE	53-57
	Aluminium-Roller Guide PROLINE	59-61
	Aluminium-Roller Guide – PROLINE with ACTIVE-Brake	59-61
	Recirculating Ball Bearing Guide STARLINE	63-69
	– Variable stop VS	66-69
	Recirculating Ball Bearing Guide KF	71-77
	– Variable stop VS	74-77
	Heavy Duty Guide HD	79-86
	– Variable stop VS	82
	– Intermediate stop module ZSM	83-86

Brakes		Page
	Overview	87-88
ACTIVE-Brakes		
	ACTIVE-Brake – for Standard Cylinder	89-92
	Plain Bearing Guide SLIDELINE – with ACTIVE-Brake	49-51
	Aluminium-Roller Guide PROLINE with ACTIVE-Brake	59-61
PASSIVE-Brakes		
	Multi-Brake: PASSIVE-Brake with Plain Bearing Guide SLIDELINE	93-96
	Multi-Brake: PASSIVE-Brake with Aluminium-Roller Guide PROLINE	97-99
OSP –Accessories		
	Overview	101-102
	Clevis Mounting	103-104
	End Cap Mounting	105
	Mid-Section Support	106
	Mountings for Linear Drives fitted with OSP-Guides	107-115
	Inversion Mounting	117
	Adaptor Profile	118
	T-Slot Profile	119
	Connection Profile	120
	Duplex Connection	121
	Multiplex Connection	122
Magnetic Switches		
	– T-Slot Version	123-126
	– ATEX-Version  on request	
	Cable Cover	127
Displacement Measuring Systems ORIGA SENSOFLEX		
	Overview	129-130
	– Series SFI-plus	129 -133

The right to introduce technical modifications is reserved

The  
System Concept

## ONE CONCEPT – THREE DRIVE OPTIONS

Based on the Parker Origa rodless cylinder, proven in world wide markets, Parker Origa now offers the complete solution for linear drive systems. Designed for absolute reliability, high performance, ease of use and optimised engineering the ORIGA SYSTEM PLUS satisfies even the most demanding applications.

### ORIGA SYSTEM PLUS

is a totally modular concept which offers the choice of pneumatic or electric actuation, with guidance and control modules to suit the exact needs of individual installations.

The actuators at the core of the system all have a common aluminium extruded profile, with double dovetail mounting rails on three sides, these

are the principle building blocks of the system to which all modular options are directly attached.



### SYSTEM MODULARITY

#### • Pneumatic Drive

– For all round versatility and convenience, combining ease of control and broad performance capability. Ideally suited for point-to point operations, reciprocating movements and simple traverse / transfer applications.

#### • Electric Screw Drive

– For high force capability and accurate path and position control.

**For additional information on electrical linear drives OSP-E, please refer to catalogue P-A4P017E.**

#### • Electric Belt Drive

– For high speed applications, accurate path and position control and longer strokes.

**For additional informations on electrical linear drives OSP-E, please refer to catalogue P-A4 P017E.**

- Different guidance options provide the necessary level of precision, performance and duty for various applications.

- Compact solutions, which are simple to install and can be easily retro-fitted.

- Valves and control options can be directly mounted to the actuator system.

- Diverse mounting options to provide total installation flexibility.



# INTRODUCTION OSP - CONCEPT

\* Information on electrical linear drives series OSP-E, please refer to catalogue P-A4P017GB

<p>Basic Linear Drive Standard Version</p> <ul style="list-style-type: none"> <li>● Series OSP-P</li> <li>● Series OSP-E*</li> <li>Belt drive</li> <li>Belt drive with integrated Guides</li> <li>Vertical belt drive with recirculating ball bearing guide</li> <li>● Series OSP-E*</li> <li>Screw drive (Ball Screw, Trapezoidal Screw)</li> </ul>		<p>BASIC GUIDE</p> <ul style="list-style-type: none"> <li>● Series OSPP-BG</li> </ul>	
<p>Air Connection on the End-face or both at One End</p> <ul style="list-style-type: none"> <li>● Series OSP-P</li> </ul>		<p>Duplex Connection</p> <ul style="list-style-type: none"> <li>● Series OSP-P</li> </ul>	
<p>Long-Stroke Cylinders for strokes up to 41 m</p> <ul style="list-style-type: none"> <li>● Series OSP-P</li> </ul>		<p>Multiplex-Connection</p> <ul style="list-style-type: none"> <li>● Series OSP-P</li> </ul>	
<p>Clean Room Cylinder certified to DIN EN ISO 146644-1</p> <ul style="list-style-type: none"> <li>● Series OSP-P</li> <li>● Series OSP-E..SB</li> </ul>		<p>Linear Guides – SLIDELINE</p> <ul style="list-style-type: none"> <li>● Series OSP-P</li> <li>● Series OSP-E Screw drive*</li> </ul>	
<p>Products for ATEX Areas</p> <ul style="list-style-type: none"> <li>● Series OSP-P</li> <li>Rodless Cylinders</li> </ul>		<p>Linear Guides – POWERSLIDE</p> <ul style="list-style-type: none"> <li>● Series OSP-P</li> <li>● Series OSP-E Belt drive*</li> <li>● Series OSP-E Screw drive*</li> </ul>	
<p>Products for ATEX Areas</p> <ul style="list-style-type: none"> <li>● Series OSP-P</li> <li>Rodless Cylinders with Linear Guide BASIC GUIDE</li> </ul>		<p>Linear Guides – PROLINE</p> <ul style="list-style-type: none"> <li>● Series OSP-P</li> <li>● Series OSP-E Belt drive*</li> <li>● Series OSP-E Screw drive*</li> </ul>	
<p>Products for ATEX Areas</p> <ul style="list-style-type: none"> <li>● Series OSP-P</li> <li>Rodless Cylinders with Linear Guide SLIDELINE</li> </ul>		<p>Linear Guides – STARLINE</p> <ul style="list-style-type: none"> <li>● Series OSP-P</li> </ul>	
<p>Bi-parting Version</p> <ul style="list-style-type: none"> <li>● Series OSP-P</li> </ul>		<p>Linear Guides – KF</p> <ul style="list-style-type: none"> <li>● Series OSP-P</li> </ul>	
<p>Integrated 3/2 Way Valves</p> <ul style="list-style-type: none"> <li>● Series OSP-P</li> </ul>		<p>Heavy Duty Linear Guides – HD</p> <ul style="list-style-type: none"> <li>● Series OSP-P</li> <li>● Series OSP-E Screw drive*</li> </ul>	
<p>Clevis Mounting</p> <ul style="list-style-type: none"> <li>● Series OSP-P</li> <li>● Series OSP-E Belt drive*</li> <li>● Series OSP-E Screw drive*</li> </ul>		<p>Intermediate stop module – ZSM</p> <ul style="list-style-type: none"> <li>● Series OSP-P</li> </ul>	
<p>End Cap Mounting</p> <ul style="list-style-type: none"> <li>● Series OSP-P</li> <li>● Series OSP-E Belt drive*</li> <li>● Series OSP-E Screw drive*</li> </ul>		<p>Brakes</p> <ul style="list-style-type: none"> <li>● ACTIVE Brakes</li> <li>● Passive Brakes</li> </ul>	
<p>Mid-Section Support</p> <ul style="list-style-type: none"> <li>● Series OSP-P</li> <li>● Series OSP-E Belt drive*</li> <li>● Series OSP-E Screw drive*</li> </ul>		<p>Magnetic Switches</p> <ul style="list-style-type: none"> <li>● Series OSP-P</li> <li>● Series OSP-E Belt drive*</li> <li>● Series OSP-E Screw drive*</li> <li>● ATEX-Versions</li> </ul>	
<p>Inversion Mounting</p> <ul style="list-style-type: none"> <li>● Series OSP-P</li> <li>● Series OSP-E Belt drive*</li> <li>● Series OSP-E Screw drive*</li> </ul>		<p>SENSOFLEX-Measuring system</p> <ul style="list-style-type: none"> <li>● Series SFI-plus</li> </ul>	
		<p>Variable Stop VS</p> <ul style="list-style-type: none"> <li>● Series OSP-P with Linear Guide STL, KF, HD</li> </ul>	

The right to introduce technical modifications is reserved

Linear Drives	OSP-P10	OSP-P16	OSP-P25	OSP-P32	OSP-P40	OSP-P50	OSP-P63	OSP-P80
Theoretical force at 6 bar [N]	47	120	295	483	754	1178	1870	3010
Effective force at 6 bar [N]	32	78	250	420	640	1000	1550	2600
Velocity v [m/s]	>0.005	>0.005	>0.005	>0.005	>0.005	>0.005	>0.005	>0.005
Magnetic piston (three sides)	X	□	□	□	□	□	□	□
Lubrication - prelubricated	□	□	□	□	□	□	□	□
Multiple air ports (4 x 90°)	X	□	□	□	□	□	□	□
Both Air Connections at End-face	X	○	○	○	○	○	○	○
Air Connection on the End-face	X	○	○	○	○	○	○	○
Cushioning	□	□	□	□	□	□	□	□
Cushioning length [mm]	2,50	11	17	20	27	30	32	39
Stroke length [mm]	1-6000	1-6000	1-6000	1-6000	1-6000	1-6000	1-6000	1-6000
Pressure range p <sub>max</sub> [bar]	8.0	8.0	8.0	8.0	8.0	8.0	8.0	8.0
Temperature range [°C]	-10-+80	-10-+80	-10-+80	-10-+80	-10-+80	-10-+80	-10-+80	-10-+80
Viton / chemical resistance	○	○	○	○	○	○	○	○
Stainless steel parts	○	○	○	○	○	○	○	○
Clevis Mounting	○	○	○	○	○	○	○	○
Slow speed lubrication	○	○	○	○	○	○	○	○
Duplex Connection / Multiplex Connection	X	on request	○	○	○	○	on request	on request
Tandem piston	○	○	○	○	○	○	○	○
<b>Basic Cylinder</b>								
F [N]	20	120	300	450	750	1200	1650	2400
M <sub>x</sub> [Nm]	0.2	0.45	1.5	3	6	10	12	24
M <sub>y</sub> [Nm]	1	4	15	30	60	115	200	360
M <sub>z</sub> [Nm]	0.3	0.5	3	5	8	15	24	48
<b>Basic Guide</b>								
F [N]	X	X	590	850	1600	2000	X	X
M <sub>x</sub> [Nm]	X	X	10	17	39	67	X	X
M <sub>y</sub> [Nm]	X	X	28	43	110	165	X	X
M <sub>z</sub> [Nm]	X	X	28	43	110	165	X	X
<b>Slideline</b>								
F [N]	X	325	675	925	1600	2000	2500	2500
M <sub>x</sub> [Nm]	X	6	14	29	50	77	120	120
M <sub>y</sub> [Nm]	X	11	34	60	110	180	260	260
M <sub>z</sub> [Nm]	X	11	34	60	110	180	260	260
<b>Proline</b>								
F [N]	X	542	857	1171	2074	3111	X	X
M <sub>x</sub> [Nm]	X	8	16	29	57	111	X	X
M <sub>y</sub> [Nm]	X	12	39	73	158	249	X	X
M <sub>z</sub> [Nm]	X	12	39	73	158	249	X	X
<b>Powerslide</b>								
F [N]	X	1400	1400-3000	1400-3000	3000	3000-4000	X	X
M <sub>x</sub> [Nm]	X	14	14-65	20-65	65-90	90-140	X	X
M <sub>y</sub> [Nm]	X	45	63-175	70-175	175-250	250-350	X	X
M <sub>z</sub> [Nm]	X	45	63-175	70-175	175-250	250-350	X	X
<b>Starline</b>								
F [N]	X	1000	3100	3100	4000-7500	4000-7500	X	X
M <sub>x</sub> [Nm]	X	15	50	62	150	210	X	X
M <sub>y</sub> [Nm]	X	30	110	160	400	580	X	X
M <sub>z</sub> [Nm]	X	30	110	160	400	580	X	X
- variable Stop	X	○	○	○	○	○	X	X

Linear Drives	OSP-P10	OSP-P16	OSP-P25	OSP-P32	OSP-P40	OSP-P50	OSP-P63	OSP-P80
<b>KF-Guide</b>								
F [N]	X	1000	3100	3100	4000-7100	4000-7500	X	X
M <sub>x</sub> [Nm]	X	12	35	44	119	170	X	X
M <sub>y</sub> [Nm]	X	25	90	133	346	480	X	X
M <sub>z</sub> [Nm]	X	25	90	133	346	480	X	X
– variable Stop	X	○	○	○	○	○	X	X
<b>HD Heavy Duty Guide</b>								
F [N]	X	X	6000	6000	15000	18000	X	X
M <sub>x</sub> [Nm]	X	X	260	285	800	1100	X	X
M <sub>y</sub> [Nm]	X	X	320	475	1100	1400	X	X
M <sub>z</sub> [Nm]	X	X	320	475	1100	1400	X	X
– Variable Stop	X	X	○	○	○	○	X	X
– Intermediate stop module	X	X	○	X	X	X	X	X
<b>ACTIVE Brake</b>								
Braking force at 6 bar (brake surface dry) [N]	X	X	350	590	900	1400	2170	4000
<b>Slideline SL / Proline PL with Brakes</b>								
<b>ACTIVE Brake</b>								
SL Braking force at 6 bar (brake surface dry) [N]	X	X	325	545	835	1200	X	X
PL Braking force at 6 bar (brake surface dry) [N]	X	X	on request	on request	on request	on request	X	X
<b>Passive Brake Multibrake</b>								
SL Braking force (brake surface dry) [N]	X	X	470	790	1200	1870	2900	2900
PL Braking force (brake surface dry) [N]	X	X	315	490	715	1100	–	–
<b>Magnetic Switches</b>								
T-Slot-Version	○	○	○	○	○	○	○	○
ATEX-Version for EX- Areas 	○	○	○	○	○	○	○	○
<b>Displacement measuring systems</b>								
SFI-plus incremental	X	X	○	○	○	○	○	○
<b>Integrated valves 3/2 WV NOVOE</b>	X	X	○	○	○	○	on request	on request
<b>Mountings</b>								
End Cap Mounting / Mid-Section Support	○	○	○	○	○	○	○	○
Inversion Mounting	X	○	○	○	○	○	○	○
Shock absorber for intermediate positioning	X	X	on request	on request	on request	on request	X	X
Adaptor Profile / T-Slot Profile	X	○	○	○	○	○	○/X	X
<b>Special Cylinders</b>								
Special Pneumatical Cushioning System	X	on request	on request	on request	on request	on request	X	X
Clean Room Cylinders to DIN EN ISO 14644-1	X	○	○	○	X	X	X	X
Long-Stroke Cylinders (max. stroke length 41 m)	X	X	X	X	X	○	○	○
ATEX-Version for EX-Areas 	○	○	○	○	○	○	○	○
Bi-parting Version	X	X	X	X	○	X	X	X
High-Speed up to 30 m/s	X	on request	on request	on request	X	X	X	X

The right to introduce technical modifications is reserved

- = Standard version
- ▲ = longer strokes on request
- \* = other temperature ranges on request
- = Option
- × = not applicable

Examples

## CONTROL EXAMPLES FOR OSP-P

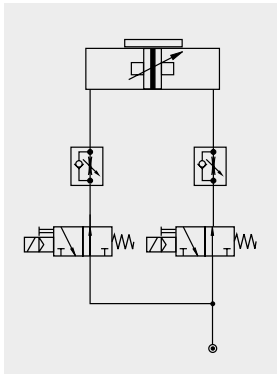

Circuit diagram for end of stroke application. Intermediate positioning is also possible.

The cylinder is controlled by two 3/2-way valves (normally open). The speed can be adjusted independantly for both directions.

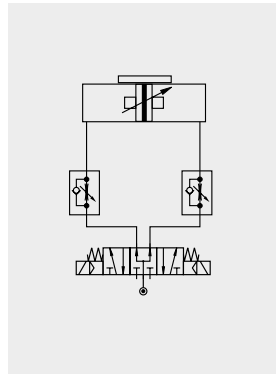

Circuit diagram for end of stroke application. Intermediate positioning is also possible.

The cylinder is controlled by a 5/3-way valve (middle position pressurized). The speed can be adjusted independantly for both directions.

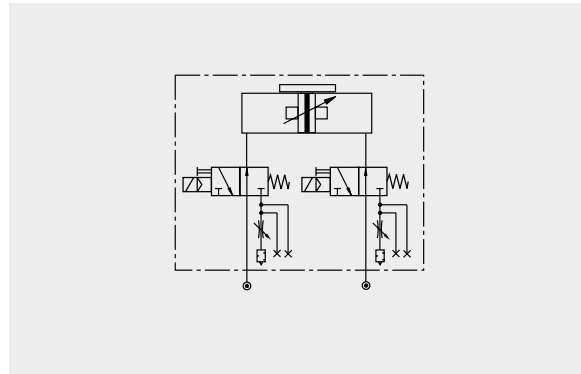

The optional integrated VOE Valves offer optimal control, and allow accurate

positioning of intermediate positions and the lowest possible speeds.

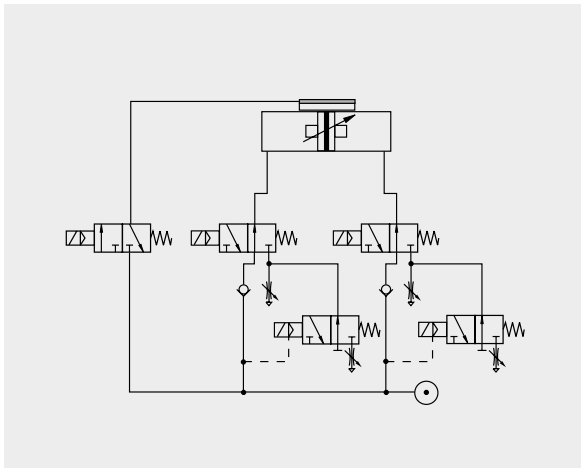

Fast/Slow speed cycle control with pneumatic brake for accurate positioning at high velocities. Additional 3/2-way valves with adjustable throttle valves at the exhaust of the standard directional control valves for two displacement

speeds in each direction of the piston's travel. The valve controlling the brake is activated after the slow speed cycle is activated

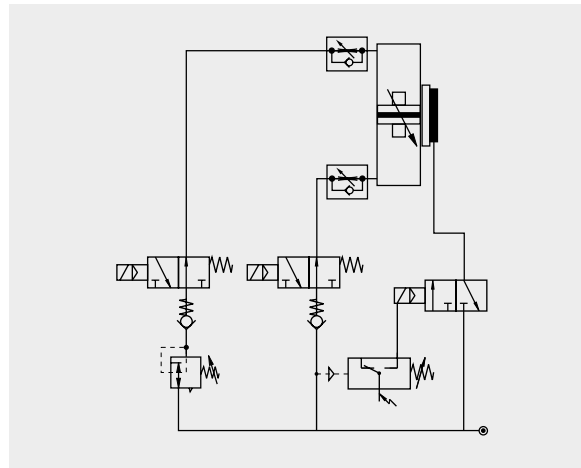

The combination of an OSP-cylinder with the passive MULTIBRAKE as shown here, allows accurate positioning and safety in case of loss of pneumatic air pressure.

Examples

## OSP-P APPLICATION EXAMPLES

ORIGA SYSTEM PLUS – rodless linear drives offer maximum flexibility for any application.

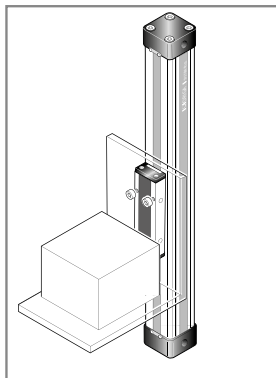

The high load capacity of the piston can cope with high bending moments without additional guides.

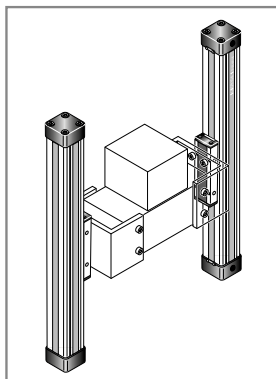
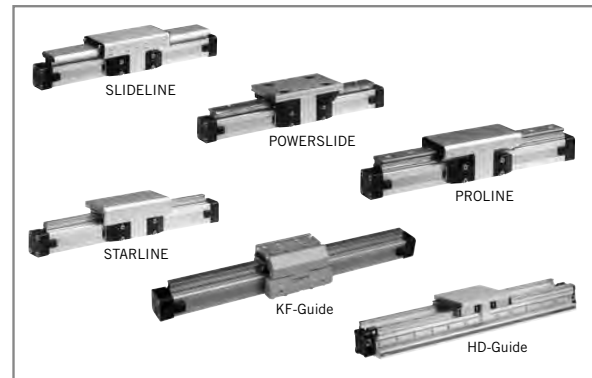

The mechanical design of the OSP-P allows synchronised movement of two cylinders.

Integrated guides offer optimal guidance for applications requiring high performance, easy assembly and maintenance free operation.

Optimal system performance by combining multi-axis cylinder combinations.

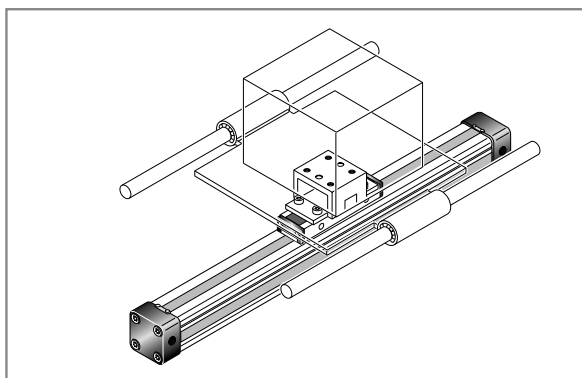

When using external guides, the clevis mounting is used to compensate for deviations in parallelism.

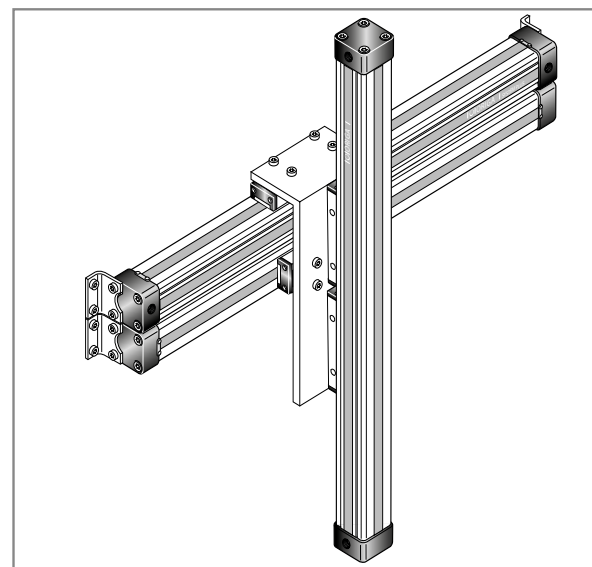

For further information and assembly instructions, please contact your local Parker Origa dealer.

The right to introduce technical modifications is reserved



# Rodless Pneumatic Cylinders Series OSP-P

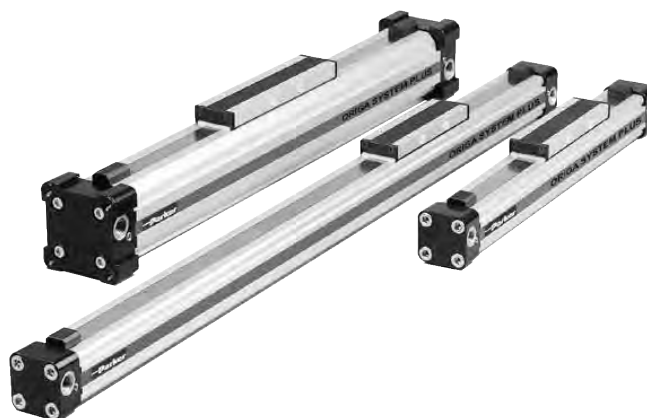

## Contents

Description	Page
<b>Standard Cylinders</b>	
Overview	9-13
Technical Data	15-17
Dimensions	18-23
Order Instructions	24
<b>Long-Stroke Cylinders</b>	
Technical Data	25-26
Dimensions	27-28
Order Instructions	29
<b>Clean Room Cylinders</b>	
Technical Data	31-32
Dimensions	33
Order Instructions	34
<b>Cylinders ATEX-Version </b>	
Technical Data	35
Dimensions	16-21
Order Instructions	36
<b>Cylinders for synchronized bi-parting movements</b>	
Technical Data	37
Dimensions	38
Order Instructions	38
<b>BASIC GUIDE BG</b>	
Technical Data	39
Dimensions	42
Order Instructions	45

The right to introduce technical modifications is reserved

The System Concept and Components

## ORIGA SYSTEM PLUS – INNOVATION FROM A PROVEN DESIGN

A completely new generation of linear drives which can be simply and neatly integrated into any machine layout.

### A NEW MODULAR LINEAR DRIVE SYSTEM

With this second generation linear drive Parker Origa offers design engineers complete flexibility. The well known ORIGA cylinder has been further developed into a combined linear actuator, guidance and control package. It forms the basis for the new, versatile ORIGA SYSTEM PLUS linear drive system.

All additional functions are designed into modular system components which replace the previous series of cylinders.

### MOUNTING RAILS ON 3 SIDES

Mounting rails on 3 sides of the cylinder enable modular components such as linear guides, brakes, valves, magnetic switches etc. to be fitted to the cylinder itself. This solves many installation problems, especially where space is limited.

The modular system concept forms an ideal basis for additional customer-specific functions.

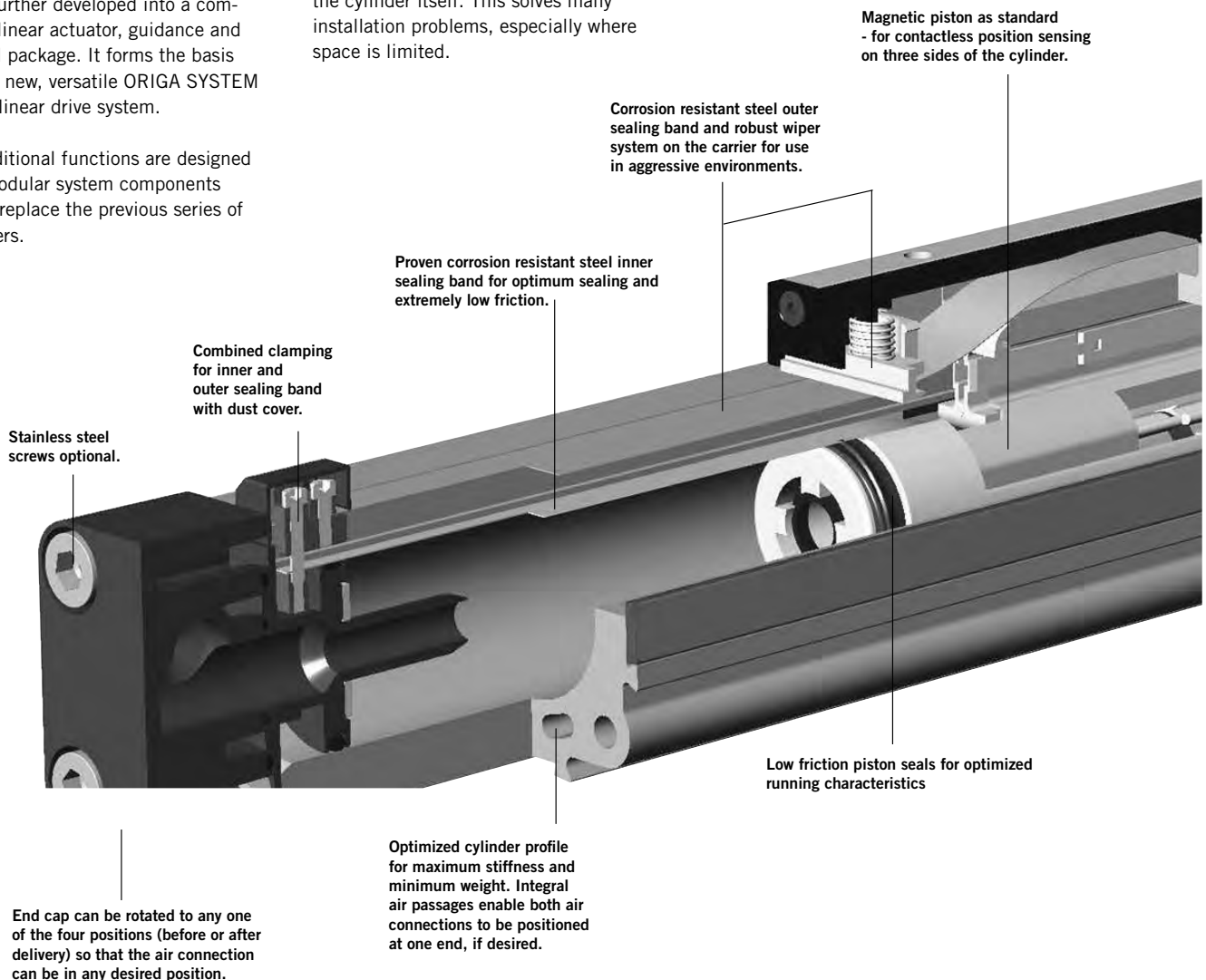

Clean Room Version  
certified to DIN EN ISO 14644-1

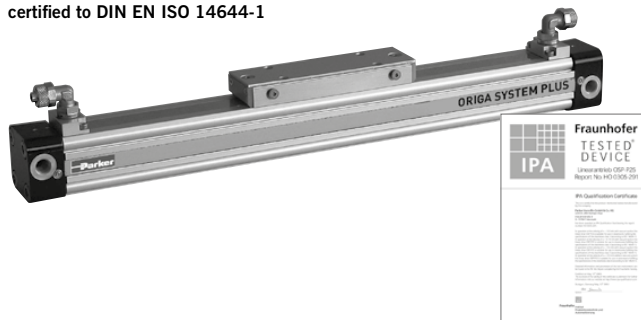

Rodless Cylinder  
for synchronized bi-parting movements

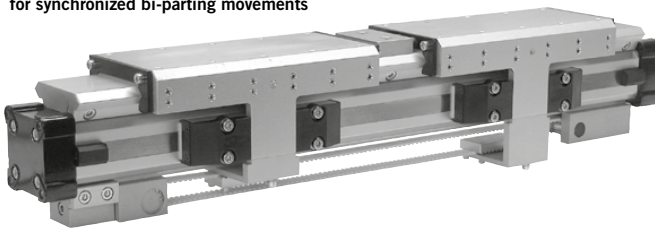

New low profile  
piston/carrier design.

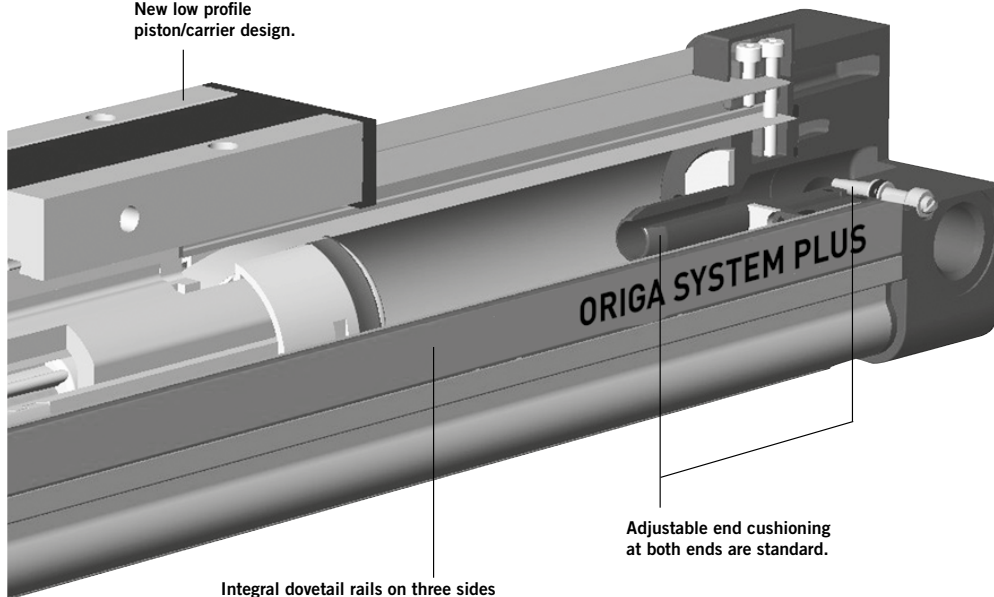

Adjustable end cushioning  
at both ends are standard.

Integral dovetail rails on three sides  
provide many adaptation possibilities  
(linear guides, magnetic switches, etc.).

Modular system components  
are simply clamped on.

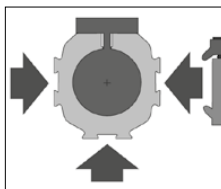

**INTEGRATED  
VOE VALVES**  
The complete compact  
solution for optimal  
cylinder control.

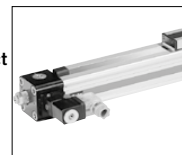

**SENSOFLEX**  
SFI-plus  
incremental  
measuring system  
with 0.1 (1.0) mm  
resolution.

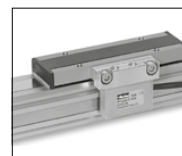

**BASIC GUIDE**  
Compact, robust plain  
bearing guide for  
medium loads.

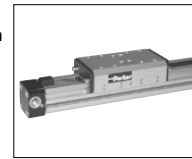

**SLIDELINE**  
Guide system  
for moderate loads.  
Optional with  
Active- / Passive-  
Brake.



**POWERSLIDE**  
Roller guide  
for high loads  
and rough  
conditions.



**PROLINE**  
The compact alu-  
minium roller guide  
for high loads and  
velocities.  
Optional with Active- /  
Passive- Brake.

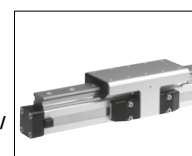

**STARLINE**  
Recirculating ball  
bearing guide for  
very high loads and  
precision.

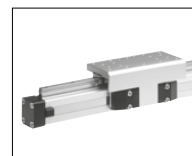

**KF GUIDE**  
Recirculating ball  
bearing guide – the  
mounting dimen-  
sions correspond  
to FESTO Type:  
DGPL-KF

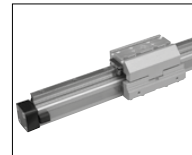

**HEAVY DUTY  
GUIDE HD**  
for heavy duty  
applications.

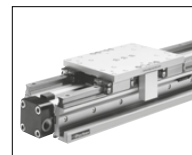

**VARIABLE STOP  
VS**  
The variable stop  
provides simple  
stroke limitation.



**PASSIVE BRAKE**  
reacts automatically  
to pressure failure.



**ACTIVE BRAKE**  
pneumatic brake  
for secure, positive  
stopping at any  
position.

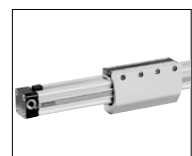

## OPTIONS AND ACCESSORIES FOR SYSTEM VERSATILITY

### SERIES OSP-P

#### STANDARD VERSIONS OSP-P10 to P80

Page 15-17

Standard carrier with integral guidance. End cap can be rotated 4 x 90° to position air connection on any side.

Magnetic piston as standard.  
Dovetail profile for mounting of accessories and the cylinder itself.

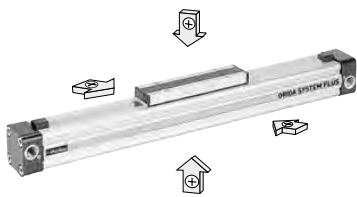

#### LONG-STROKE VERSION Page 25-29

For extremely long strokes up to max. 41 m



#### BASIC CYLINDER OPTIONS

##### CLEAN ROOM CYLINDERS Page 31-34

For use in clean room applications, certified with the IPA-Certificate (to DIN EN ISO 14644-1). The special design of the linear drive enables all emissions to be led away.



##### ATEX-Version Page 35-36

For use in Ex-Areas



##### STAINLESS VERSION

For use in constantly damp environments. All screws are A2 quality stainless steel (material no.1.4301 / 1.4303)



##### SLOW SPEED OPTIONS

Specially formulated grease lubrication facilitates slow, smooth and uniform piston travel in the speed range from 0.005 to 0.2 m/s.

Minimum achievable speeds are dependent on several factors. Please consult our technical department.  
Slow speed lubrication in combination with Viton® on demand.  
Oil free operation preferred.



##### VITON® VERSION

For use in an environment with high temperatures or in chemically aggressive areas. All seals are made of Viton®. Sealing bands: Stainless steel.



##### END-FACE AIR CONNECTION

Page 20

To solve special installation problems.



##### BOTH AIR CONNECTIONS AT ONE END

Page 21

For simplified tubing connections and space saving.



##### INTEGRATED VOE VALVES

Page 22

The complete compact solution for optimal cylinder control.



##### DUPLEX CONNECTION

Page 121

The duplex connection combines two OSP-P cylinders of the same size into a compact unit with high performance.



##### MULTIPLY CONNECTION

Page 122

The multiplex connection combines two or more OSP-P cylinders of the same size into one unit. The orientation of the carriers can be freely selected.



**MAGNETIC SWITCHES  
TYPE RST, EST**

Page 123-126

For electrical sensing of end and intermediate piston positions, also in EX-Areas.



**MOUNTINGS FOR  
OSP-P10 UP TO P80**

**CLEVIS MOUNTING**

Page 103-104

Carrier with tolerance and parallelism compensation for driving loads supported by external linear guides.

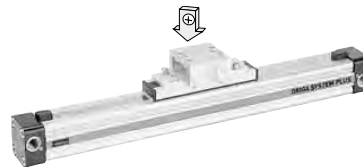

**END CAP MOUNTING**

Page 105

For end-mounting of the cylinder.



**MID-SECTION SUPPORT**

Page 106

For supporting long cylinders or mounting the cylinder by its dovetail rails.



**INVERSION MOUNTING**

Page 117

The inversion mounting transfers the driving force to the opposite side, e. g. for dirty environments.





Characteristics		Pressures quoted as gauge pressure	
Characteristics	Symbol	Unit	Description
<b>General Features</b>			
Type			Rodless cylinder
Series			OSP-P
System			Double-acting, with cushioning, position sensing capability
Mounting			see drawings
Air Connection			Threaded
Ambient temperature range	$T_{min}$ $T_{max}$	°C °C	- 10 + 80   other temperature ranges on request  In case of high temperature fluctuations - please contact our product support.
Weight (mass)		kg	see table below
Installation			In any position
Medium			Filtered, unlubricated compressed air (other media on request)
Lubrication			Permanent grease lubrication (additional oil mist lubrication not required) Option: special slow speed grease
Material	Cylinder profile		Anodized aluminium
	Carrier (piston)		Anodized aluminium
	End caps		Aluminium, lacquered / Plastic (P10)
	Sealing bands		Corrosion resistant steel
	Seals		NBR (Option: Viton®)
	Screws		Galvanized steel Option: stainless steel
Dust covers, wipers			Plastic
Max. operating pressure	$P_{max}$	bar	8

Weight (mass) [kg]		
Series (Basic cylinder)	Weight (mass) [kg]	
	at 0 mm stroke	per 100 mm stroke
OSP-P10	0.087	0.052
OSP-P16	0.22	0.1
OSP-P25	0.65	0.197
OSP-P32	1.44	0.354
OSP-P40	1.95	0.415
OSP-P50	3.53	0.566
OSP-P63	6.41	0.925
OSP-P80	12.46	1.262

Size Comparison							
P10	P16	P25	P32	P40	P50	P63	P80
For <b>linear guides</b> see from page 47 For <b>magnetic switches</b> see from page 123 For <b>mountings and accessories</b> see from page 101							

# Rodless Pneumatic Cylinder

∅ 10-80 mm

**OSP**  
— ORIGA  
— SYSTEM  
— PLUS



Series OSP-P..

### Standard Versions:

- Double-acting with adjustable end cushioning
- With magnetic piston for position sensing

### Long-Stroke Cylinders for stroke lengths up to 41 m

(see page 25-29)

### Special Versions:

- with special pneumatic cushioning system (on request)
- Clean room cylinders (see page 31-34)
- ATEX-Version (Ex) (see page 35-36)
- Stainless steel screws
- Slow speed lubrication
- Viton® seals
- Both air connections on one end
- Air connection on the end-face
- Integrated Valves



- End cap can be rotated 4 x 90° to position air connection as desired
- Free choice of stroke length up to 6000 mm, Long-Stroke version (∅50-80mm) for stroke lengths up to 41 m

The right to introduce technical modifications is reserved

## Loads, Forces and Moments

Choice of cylinder is decided by:

- Permissible loads, forces and moments
- Performance of the pneumatic end cushions. The main factors here are the mass to be cushioned and the piston speed at start of cushioning (unless external cushioning is used, e. g. hydraulic shock absorbers).

The adjacent table shows the maximum values for light, shock-free operation, which must not be exceeded even in dynamic operation. **Load and moment data are based on speeds  $v \leq 0.5$  m/s.**

When working out the action force required, it is essential to take into account the friction forces generated by the specific application or load.

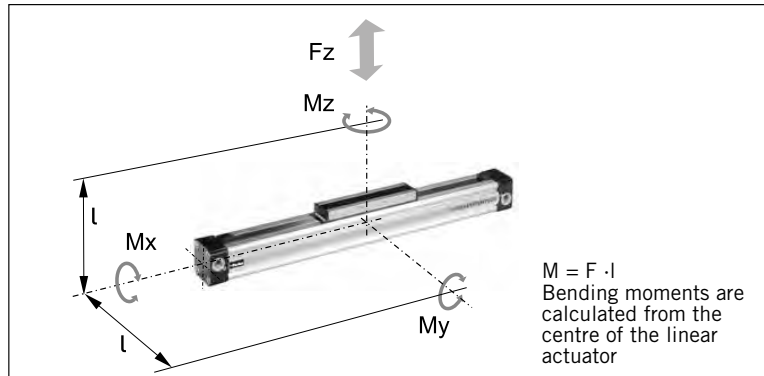

Cylinder-Series [mm Ø]	Theoretical Action Force at 6 bar [N]	effektive Action Force $F_A$ at 6 bar [N]	max. Moments			max. Load F [N]	Cushion Length [mm]
			Mx [Nm]	My [Nm]	Mz [Nm]		
OSP-P10	47	32	0.2	1	0.3	20	2.5 *
OSP-P16	120	78	0.45	4	0.5	120	11
OSP-P25	295	250	1.5	15	3	300	17
OSP-P32	483	420	3	30	5	450	20
OSP-P40	754	640	6	60	8	750	27
OSP-P50	1178	1000	10	115	15	1200	30
OSP-P63	1870	1550	12	200	24	1650	32
OSP-P80	3016	2600	24	360	48	2400	39

\* A rubber element (non-adjustable) is used for end cushioning.  
To deform the rubber element enough to reach the absolute end position would require a  $\Delta p$  of 4 bar!

## Cushioning Diagram

Work out your expected moving mass and read off the maximum permissible speed at start of cushioning. Alternatively, take your desired speed and expected mass and find the cylinder size required.

Please note that piston speed at start of cushioning is typically ca. 50 % higher than the average speed, and that it is this higher speed which determines the choice of cylinder. If these maximum permissible values are exceeded, additional shock absorbers must be used.

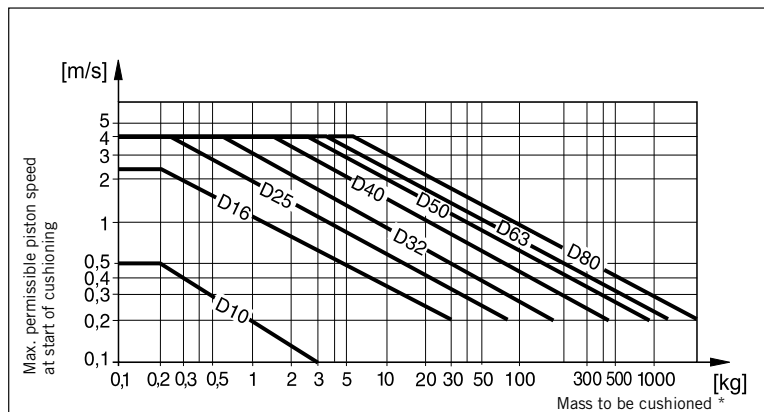

Horizontal application, pressure  $p = 6$  bar

\* For cylinders with linear guides or brakes, please be sure to take the mass of the carriage or the brake housing into account.

**If the permitted limit values are exceeded, either additional shock absorbers should be fitted in the area of the centre of gravity or you can consult us about our special cushioning system – we shall be happy to advise you on your specific application.**

### Permissible Support Spacings: OSP - P10 - P32

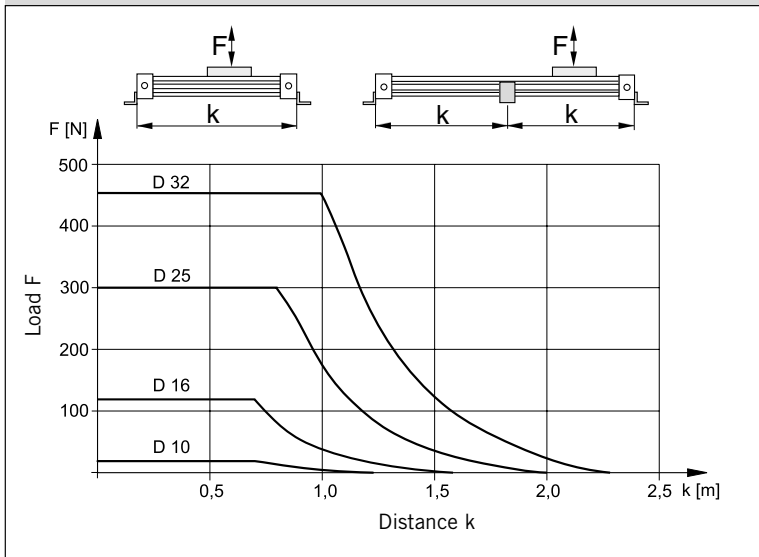

### Mid-Section Supports

To avoid excessive bending and oscillation of the cylinder, mid-section supports are required dependent on specified stroke lengths and applied loads. The diagrams show the maximum possible support spacings depending on the load.

Bending up to max. 0.5 mm is permissible between supports. The mid-section supports are clamped on to the dovetail profile of the cylinder tube. They are also able to take the axial forces.

For types and dimensions see page 106.

### Permissible Support Spacings: OSP - P40 - P80

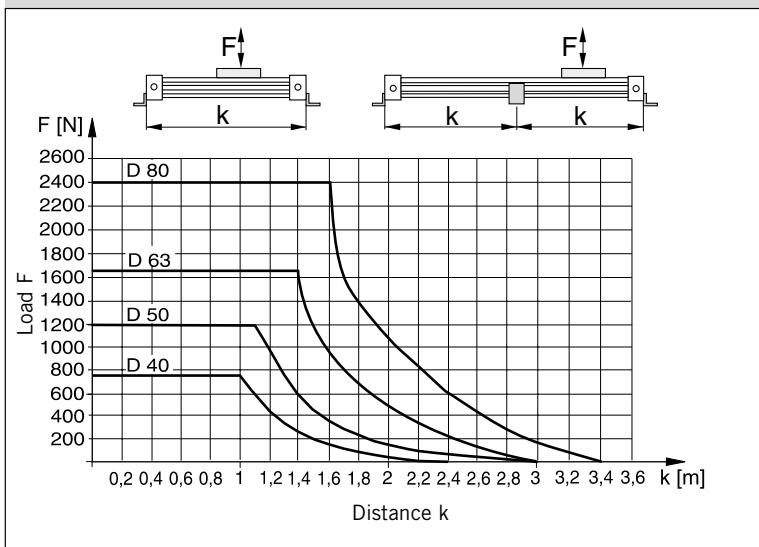

## Cylinder Stroke and Dead Length A

- Free choice of stroke length up to 6000 mm in 1 mm steps.
- Longer strokes on request

### Dimensions of Basic Cylinder OSP-P10

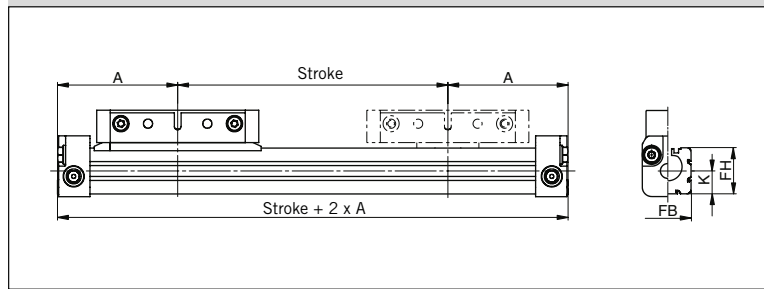

## Tandem Cylinder

Two pistons are fitted: dimension "Z" is optional. (Please note minimum distance "Zmin").

- Free choice of stroke length up to 6000 mm in 1 mm steps
- Longer strokes on request
- **Stroke length to order is stroke + dimension "Z"**

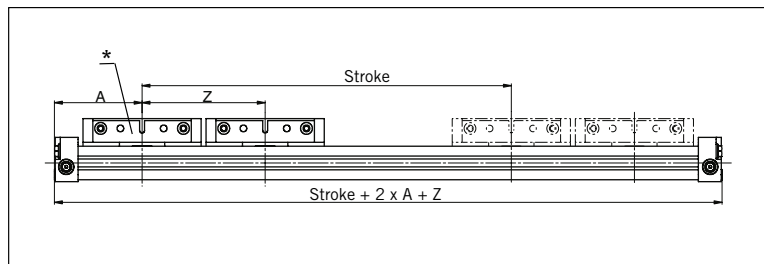

Please note:

To avoid multiple actuation of magnetic switches, the second piston is not equipped with magnets.

\* Piston with magnet

### End Cap/Air Connection Series OSP-P10

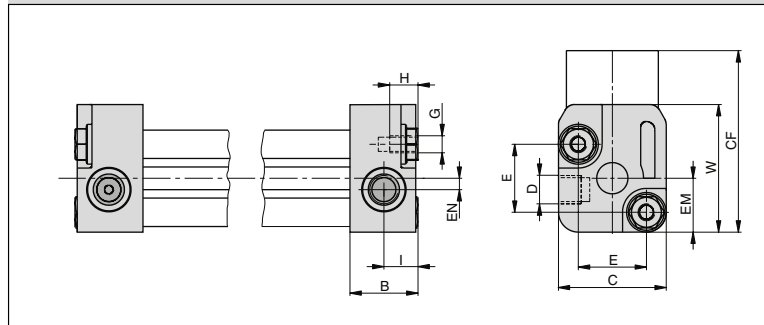

### Carrier Series OSP-P10

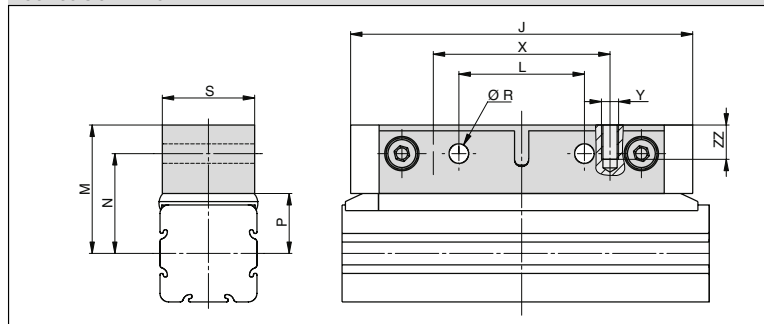

Dimension Table [mm]

Series	A	B	C	D	E	G	H	I	J	K	L	M	N	P	R	S	W	X	Y	Z <sub>min</sub>	CF	EM	EN	FB	FH	ZZ
OSP-P10	44.5	12	19	M5	12	M3	5	6	60	8.5	22	22.5	17.5	10.5	3.4	16	22.5	31	M3	64	32	9.5	2	17	17	6

### Dimensions of Basic Cylinder OSP - P16-P80

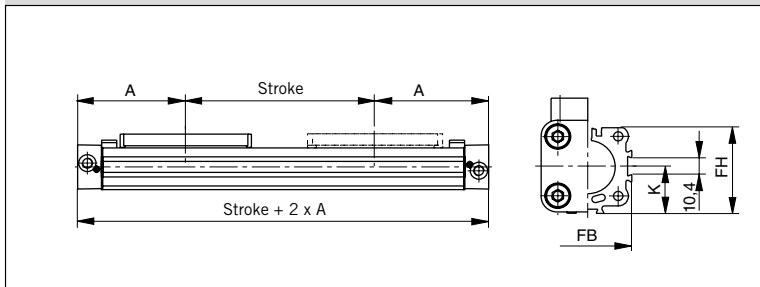

### Cylinder Stroke and Dead Length A

- Free choice of stroke length up to 6000 mm in 1 mm steps.
- Longer strokes on request.

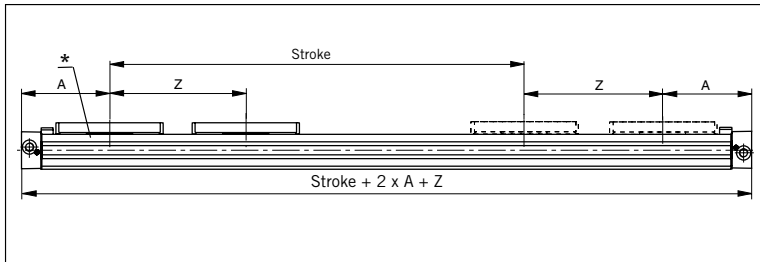

### Tandem Cylinder

Two pistons are fitted: dimension "Z" is optional. (Please note minimum distance "Zmin").

- Free choice of stroke length up to 6000 mm in 1 mm steps
- Longer strokes on request
- Stroke length to order is stroke + dimension "Z"

### End Cap/Air Connection can be rotated 4 x 90° Series OSP-P16 to P32

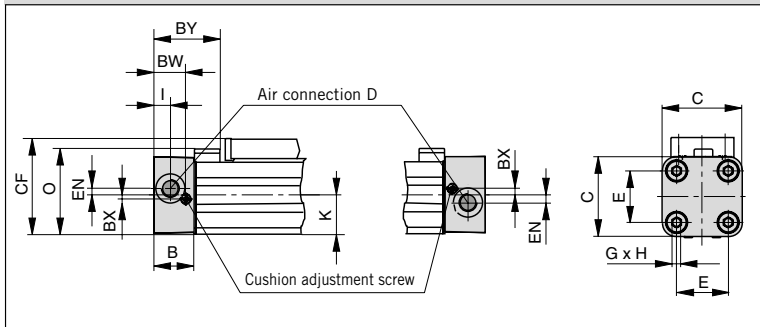

Please note:

To avoid multiple actuation of magnetic switches, the second piston is not equipped with magnets.

\* Piston with magnet

### End Cap/Air Connection can be rotated 4 x 90° Series OSP-P40 to P80

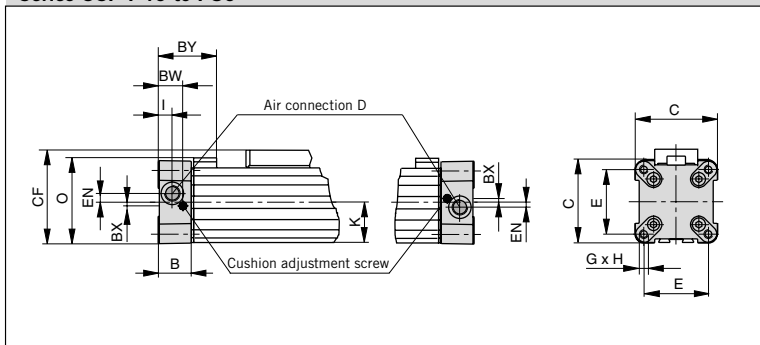

### Carrier Series OSP-P16 to P80

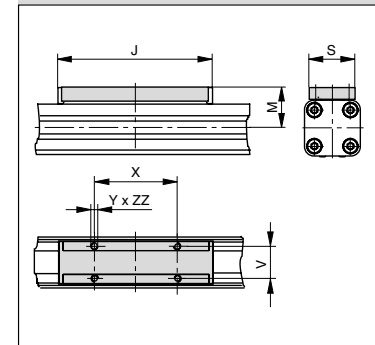

### Dimension Table [mm]

Series	A	B	C	D	E	G	H	I	J	K	M	O	S	V	X	Y	Z <sub>min</sub>	BW	BX	BY	CF	EN	FB	FH	ZZ
OSP-P16	65	14	30	M5	18	M3	9	5.5	69	15	23	33.2	22	16.5	36	M4	81	10.8	1.8	28.4	38	3	30	27.2	7
OSP-P25	100	22	41	G1/8	27	M5	15	9	117	21.5	31	47	33	25	65	M5	128	17.5	2.2	40	52.5	3.6	40	39.5	8
OSP-P32	125	25.5	52	G1/4	36	M6	15	11.5	152	28.5	38	59	36	27	90	M6	170	20.5	2.5	44	66.5	5.5	52	51.7	10
OSP-P40	150	28	69	G1/4	54	M6	15	12	152	34	44	72	36	27	90	M6	212	21	3	54	78.5	7.5	62	63	10
OSP-P50	175	33	87	G1/4	70	M6	15	14.5	200	43	49	86	36	27	110	M6	251	27	-	59	92.5	11	76	77	10
OSP-P63	215	38	106	G3/8	78	M8	21	14.5	256	54	63	107	50	34	140	M8	313	30	-	64	117	12	96	96	16
OSP-P80	260	47	132	G1/2	96	M10	25	22	348	67	80	133	52	36	190	M10	384	37.5	-	73	147	16.5	122	122	20

The right to introduce technical modifications is reserved

## Air Connection on the End-face

In some situations it is necessary or desirable to fit a special end cap with the air connection on the end-face instead of the standard end cap with the air connection on the side. The special end cap can also be rotated 4 x 90° to locate the cushion adjustment screw as desired. Supplied in pairs.



### Series OSP-P16 to P32

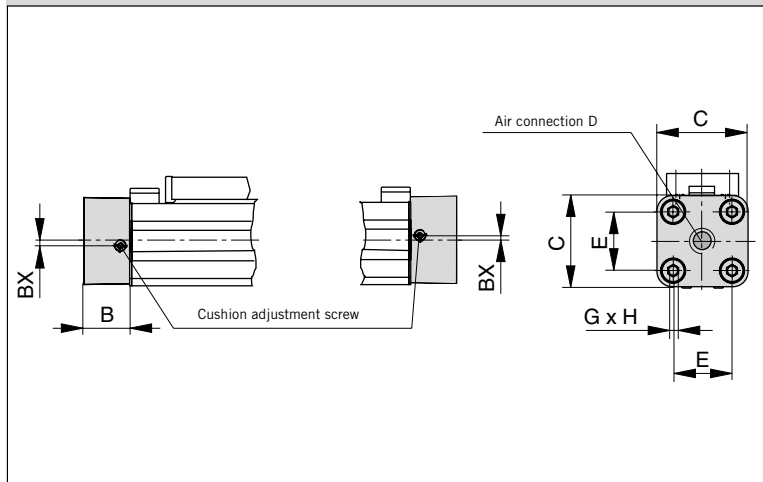

### Series OSP-P40 to P80

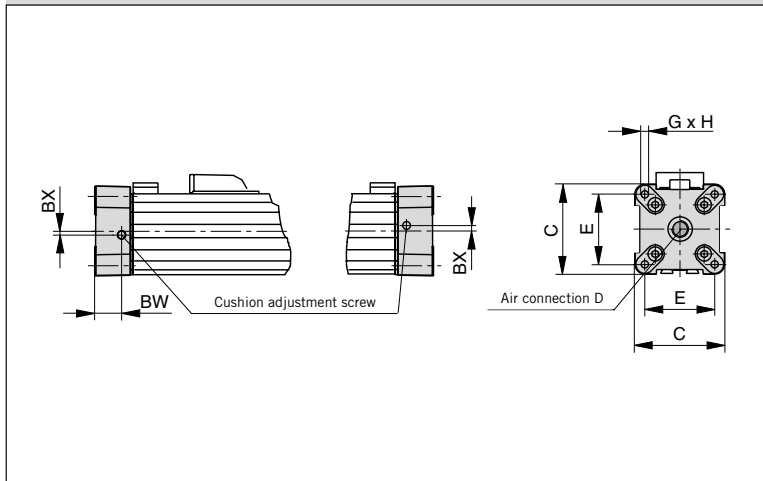

Dimension Table [mm]

Series	B	C	D	E	G	H	BX	BW
OSP-P16	14	30	M5	18	M3	9	1.8	10.8
OSP-P25	22	41	G1/8	27	M5	15	2.2	17.5
OSP-P32	25.5	52	G1/4	36	M6	15	2.5	20.5
OSP-P40	28	69	G1/4	54	M6	15	3	21
OSP-P50	33	87	G1/4	70	M6	15	–	27
OSP-P63	38	106	G3/8	78	M8	21	–	30
OSP-P80	47	132	G1/2	96	M10	25	–	37.5

### Series OSP-P16

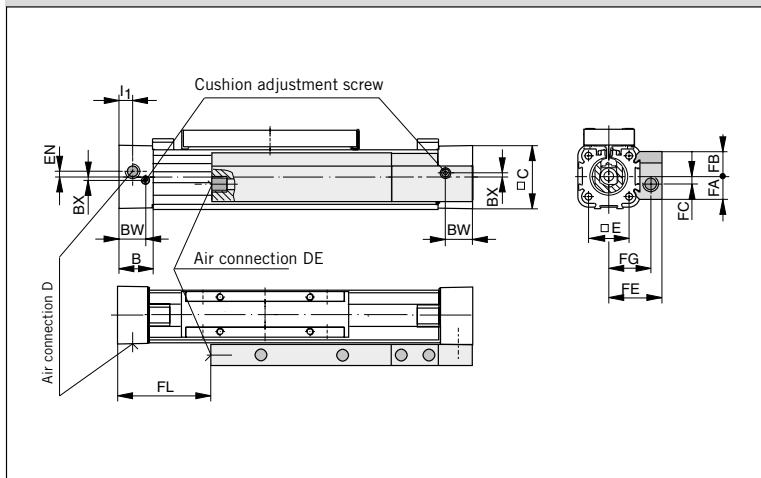

### Both Air Connections at One End

A special end cap with both air connections on one side is available for situations where shortage of space, simplicity of installation or the nature of the process make it desirable. Air supply to the other end is via internal air passages (OSP-P25 to P80) or via a hollow aluminium profile fitted externally (OSP-P16).

**In this case the end caps cannot be rotated.**



### Series OSP-P25

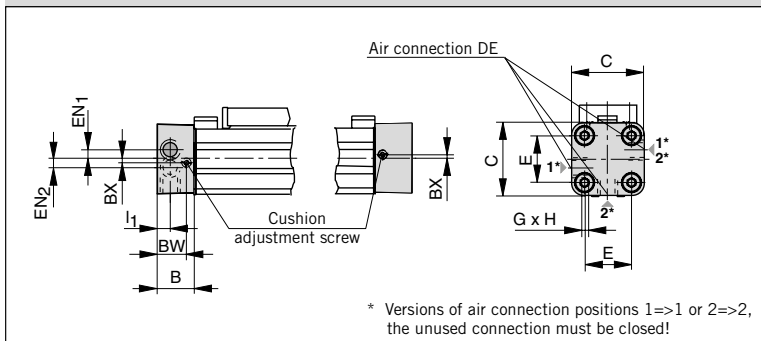

**Please note:**  
When combining the OSP-P16 single end porting with inversion mountings, RS magnetic switches can only be mounted directly opposite to the external air-supply profile.

### Series OSP-P32 to P80

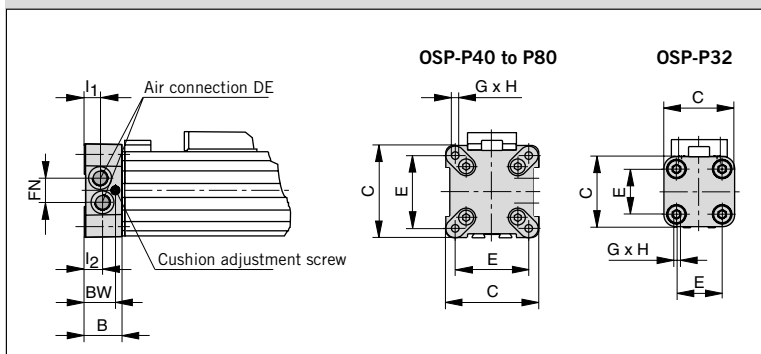

### Dimension Table [mm]

Series	B	C	E	G	H	I <sub>1</sub>	I <sub>2</sub>	BX	BW	DE	EN	EN <sub>1</sub>	EN <sub>2</sub>	FA	FB	FC	FE	FG	FL	FN
OSP-P16	14	30	18	M3	9	5.5	-	1.8	10.8	M5	3	-	-	12.6	12.6	4	27	21	36	-
OSP-P25	22	41	27	M5	15	9	-	2.2	17.5	G1/8	-	3.6	3.9	-	-	-	-	-	-	-
OSP-P32	25.5	52	36	M6	15	12.2	10.5	-	20.5	G1/8	-	-	-	-	-	-	-	-	-	15.2
OSP-P40	28	69	54	M6	15	12	12	-	21	G1/8	-	-	-	-	-	-	-	-	-	17
OSP-P50	33	87	70	M6	15	14.5	14.5	-	27	G1/4	-	-	-	-	-	-	-	-	-	22
OSP-P63	38	106	78	M8	21	16.5	13.5	-	30	G3/8	-	-	-	-	-	-	-	-	-	25
OSP-P80	47	132	96	M10	25	22	17	-	37.5	G1/2	-	-	-	-	-	-	-	-	-	34.5

The right to introduce technical modifications is reserved

## Integrated 3/2 Way Valves VOE

For optimal control of the OSP-P cylinder, 3/2 way valves integrated into the cylinder's end caps can be used as a compact and complete solution. They allow for easy positioning of the cylinder, smooth operation at the lowest speeds and fast response, making them ideally suited for the direct control of production and automation processes.

### Characteristics:

- Complete compact solution
- Various connection possibilities:
- Free choice of air connection with rotating end caps with VOE valves,
- Air connection can be rotated 4 x 90°,
- Solenoid can be rotated 4 x 90°, Pilot valve can be rotated 180°
- High piston velocities can be achieved with max. 3 exhaust ports
- Minimal installation requirements
- Requires just one air connection per valve
- Optimal control of the OSP-P cylinder
- Excellent positioning characteristics
- Integrated operation indicator
- Integrated exhaust throttle valve
- Manual override - indexed
- Adjustable end cushioning
- Easily retrofitted – please note the increase in the overall length of the cylinder!

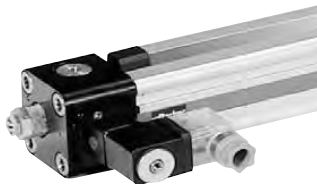

### Integrated 3/2 Way Valves VOE Series OSP-P25, P32, P40 and P50



### Characteristics 3/2 Way Valves VOE

Characteristics	3/2 Way Valves with spring return			
Pneumatic diagram				
Type	VOE-25	VOE-32	VOE-40	VOE-50
Actuation	electrical			
Basic position	P → A open, R closed			
Type	Poppet valve, non overlapping			
Mounting	integrated in end cap			
Installation	in any position			
Port size	G 1/8	G 1/4	G 3/8	G 3/8
Temperature	-10°C to +50°C *			
Operating pressure	2-8 bar			
Nominal voltage	24 V DC / 230 V AC, 50 Hz			
Power consumption	2,5 W / 6 VA			
Duty cycle	100%			
Electrical Protection	IP 65 DIN 40050			

\* other temperature ranges on request

### Dimensions VOE Valves OSP-P25 and P32

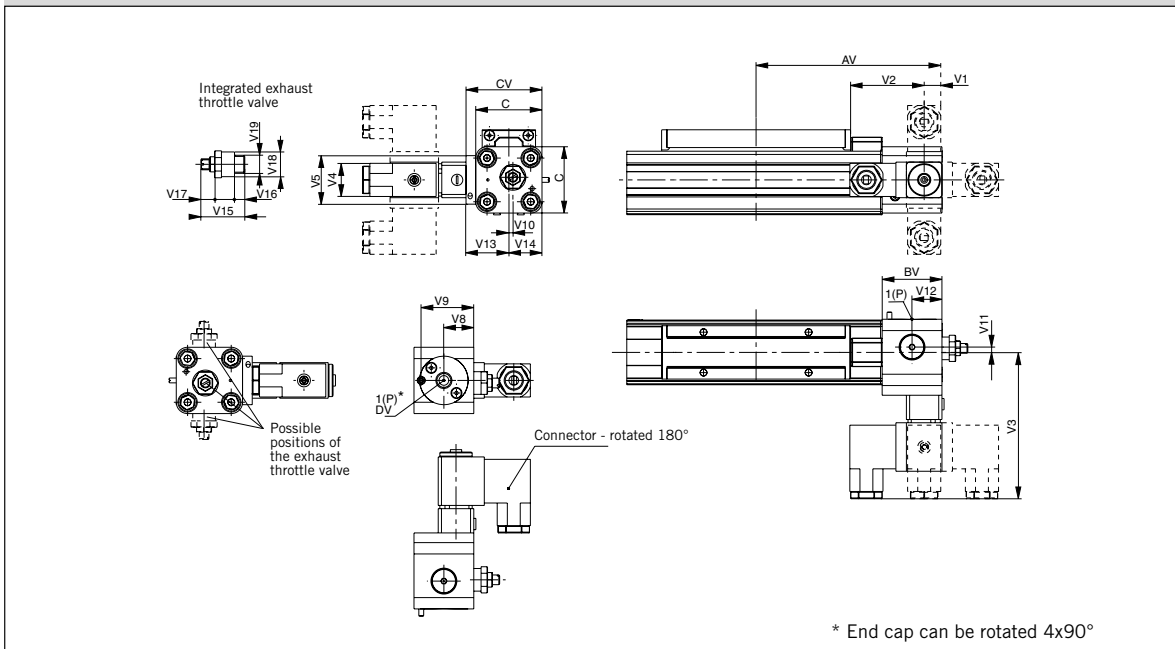

Dimension Table [mm]

Series	AV	BV	C	CV	DV	V1	V2	V3	V4	V5	V8	V9	V10	V11	V12	V13	V14	V15	V16	V17	V18	V19
OSP-P25	115	37	41	47	G1/8	11	46	90.5	22	30	18.5	32.5	2.5	3.3	18.5	26.5	20.5	24	5	4	14	G1/8
OSP-P32	139	39.5	52	58	G1/4	20.5	46	96	22	32	20.5	34.7	6	5	20.5	32	26	32	7.5	6	18	G1/4

### Dimensions VOE Valves OSP-P40 and P50

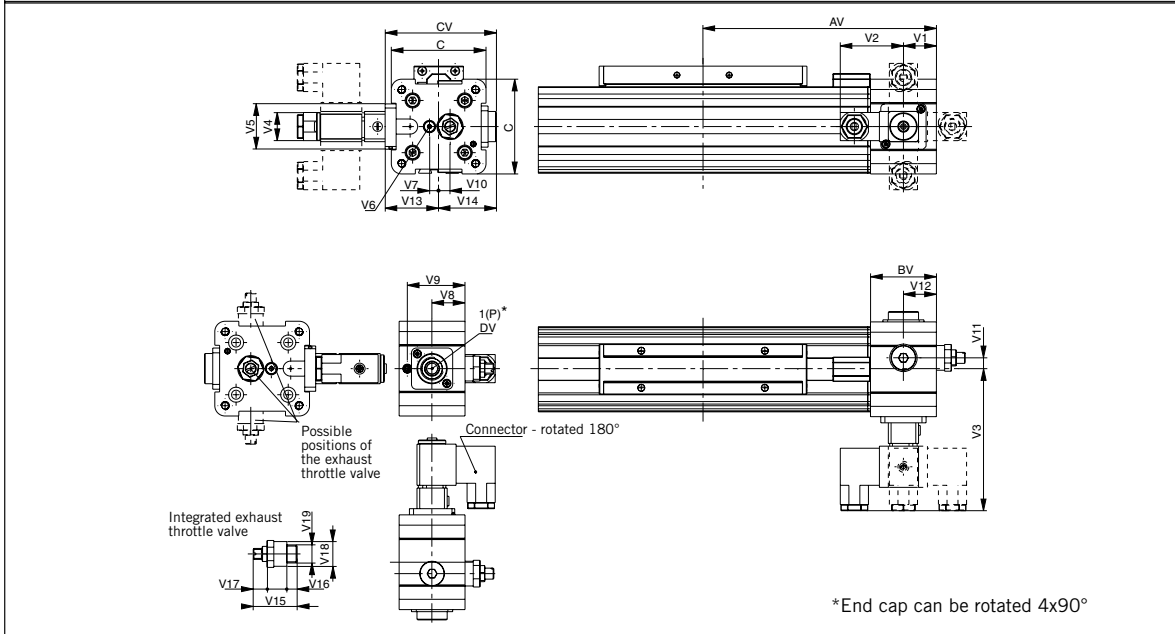

Dimension Table [mm]

Series	AV	BV	C	CV	DV	V1	V2	V3	V4	V5	V6	V7	V8	V9	V10	V11	V12	V13	V14	V15	V16	V17	V18	V19
OSP-P40	170	48	69	81	G3/8	24	46	103	22	33	M5	6.7	24	42	8.3	8.3	24	39	42	32	7.5	6	18	G1/4
OSP-P50	190	48	87	82	G3/8	24	46	102	22	33	M5	4.5	24	42	12.2	12.2	24	38	44	32	7.5	6	18	G1/4

The right to introduce technical modifications is reserved

### Order Instructions – Basic Cylinder

1-4	5+6	7	8	9	10	11	12-16	17	18	19	20	21	22	23	24	25
OSPP	25	0	0	0	0	0	01100	0	0	0	0	0	0	0	0	0

Piston-Ø
10
16
25
32
40
50
63
80

Stroke Length
In mm (5 digits)

Piston Mounting
0 without
1 clevis mounting

add. Guide Carriage
0 without

Measuring system
0 without
X SFI 0,1 mm
Y SFI 1 mm

Screws
0 standard
1 Stainless

Cushioning
0 standard
1 max. length <sup>3)</sup>

Version / Piston
0 standard
1 Tandem

Lubrication
0 standard
1 slow speed <sup>2)3)</sup>

End cap position
0 L+R 0° = in front
1 L+R 90° = underneath
2 L+R 180° = at the back
3 L + R 270° = same side as outerband
4 L 90° = underneath; R 0° = in front
5 L 180° = at the back; R 0° = in front
6 L 270° = same side as outerband; R 0° = in front
7 L 0° = in front; R 90° = underneath
8 L 180° = at the back; R 90° = underneath
9 L 270° = same side as outerband; R 90° = underneath
A L 0° = in front; R 180° = at the back
B L 90° = underneath; R 180° = at the back
C L 270° = same side as outerband; R 180° = at the back
D L 0° = in front; R 270° = same side as outerband
E L 90° = underneath; R 270° = same side as outerband
F L 180° = at the back; R 270° = same side as outerband

Brakes/ Inversion
0 without
A Activebrake AB Ø 25-80
M Inversion Ø 16-80
N Duplex Ø 25,32,40,50

Cover / Cable Channel
0 standard
1 Cable channel
2 Cable channel two-sided
X without cover rail

Air Connection
0 standard
1 end face
2 both at one end (not turnable)
3 left standard right end face
4 right standard left end face
A 3/2 Way valve VOE 24 V = Ø 25,32,40,50
B 3/2 Way valve VOE 230 V~/110 V= Ø 25,32,40,50
C 3/2 Way valve VOE 48 V = Ø 25,32,40,50
E 3/2 Way valve VOE 110 V~ Ø 25,32,40,50

Seals
0 standard (NBR)
1 Viton <sup>® 1)</sup>

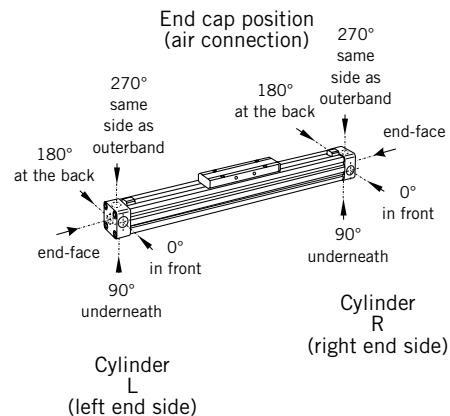

<sup>1)</sup> Viton with VOE not available.  
<sup>2)</sup> Slow speed lubrication in combination with Viton® seals on demand  
<sup>3)</sup> „Lubrication slow speed“ in combination with „max. cushioning length“ not possible.

#### Accessories - please order separately

Description	Further information see
End Cap Mountings	Page 105
Mid-Section Support	Page 106
Adaptor Profile	Page 118
T-Slot Profile	Page 119
Connection Profile	Page 120
Multiplex Connection	Page 122
Magnetic Switches	Page 123- 126

Characteristics		Pressures quoted as gauge pressure	
Characteristics	Symbol	Unit	Description
<b>General Features</b>			
Type			Rodless cylinder
Series			OSP-P
System			Double-acting, with cushioning, position sensing capability
Mounting			See drawings
Air Connection			Threaded
Ambient temperature range	$T_{min}$ $T_{max}$	°C °C	+10 +40 Other temperature ranges on request
Weight (mass)		kg	See table below
Installation			vertical, horizontal (piston at top or at bottom)
Medium			Filtered, unlubricated compressed air (other media on request)
Lubrication			Permanent grease lubrication (additional oil mist lubrication not required) Option: special slow speed grease
Material	Cylinder Profile		Anodized aluminium
	Carrier (piston)		Anodized aluminium
	End caps		Anodized aluminium
	Sealing bands		Corrosion resistant steel
	Seals		NBR (Option: Viton®)
	Screws		Galvanized steel Option: stainless steel
	Dust covers, wipers		Plastic
Max. operating pressure	$p_{max}$	bar	8
Max. speed	$v$	m/s	2

Weight (mass) [kg]		
Series (Basic cylinder)	At 0 mm stroke	Weight (mass) [kg] per 100 mm stroke
OSP-P50LS	3,53	0,566
OSP-P63LS	6,41	0,925
OSP-P80LS	12,46	1,262

Size Comparison		
P50	P63	P80

For magnetic switches see from page 123  
Accessories see from page 101

# Rodless Pneumatic Cylinder

Ø 50-80 mm



## Long-Stroke Cylinder for strokes up to 41 m

Series OSP-P..LS

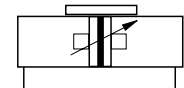

### Standard Versions:

- Double-acting with adjustable end cushioning
- With magnetic piston for position sensing

### Special Versions:

- Stainless steel screws
- Slow speed lubrication
- Viton® seals

### Options:

- Displacement measuring system SFI-plus
- Active Brake AB..

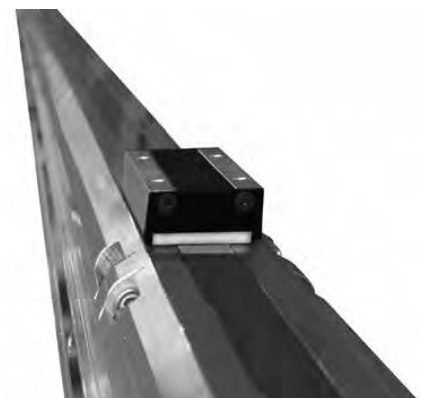

The right to introduce technical modifications is reserved

## Loads, Forces and Moments

Choice of cylinder is decided by:

- permissible loads, forces and moments
- performance of the pneumatic end cushions. The main factors here are the mass to be cushioned and the piston speed at start of cushioning (unless external cushioning is used, e. g. hydraulic shock absorbers).

The adjacent table shows the maximum values for light, shock-free operation, which must not be exceeded even in dynamic operation. **Load and moment data are based on speeds  $v \leq 0.5$  m/s.**

When working out the action force required, it is essential to take into account the friction forces generated by the specific application or load.

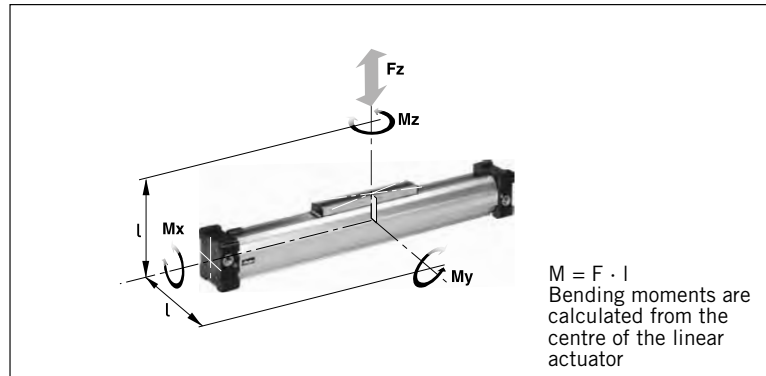

Series [mm Ø]	Theoretical Action Force at 6 bar [N]	effektive Action Force $F_A$ at 6 bar [N]	max. Moments			max. Load F [N]	Cushion Length [mm]
			Mx [Nm]	My [Nm]	Mz [Nm]		
OSP-P50LS	1178	1000	10	115	15	1200	30
OSP-P63LS	1870	1550	12	200	24	1650	32
OSP-P80LS	3016	2600	24	360	48	2400	39

## Cushioning Diagram

Work out your expected moving mass and read off the maximum permissible speed at start of cushioning. Alternatively, take your desired speed and expected mass and find the cylinder size required.

Please note that piston speed at start of cushioning is typically ca. 50 % higher than the average speed, and that it is this higher speed which determines the choice of cylinder. If these maximum permissible values are exceeded, additional shock absorbers must be used.

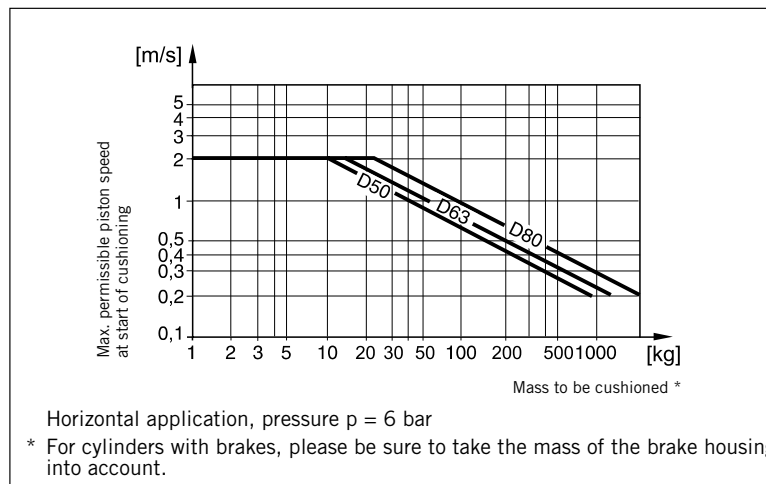

**If the permitted limit values are exceeded, additional shock absorbers should be fitted in the area of the centre of gravity .**

### Dimensions of Basic Cylinder OSP - P50LS to P80LS

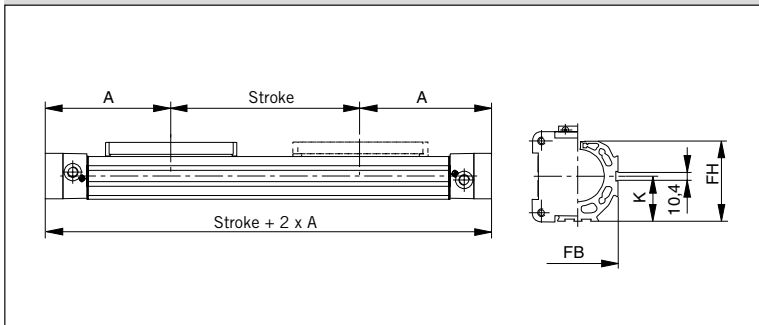

### Cylinder Stroke and Dead Length A

- Free choice of stroke length up to 41.000 mm in 1 mm steps

### Tandem Cylinder

Two pistons are fitted: dimension "Z" is optional. (Please note minimum distance "Zmin").

- Free choice of stroke length up to 41.000 mm in 1 mm steps
- Stroke length to order is stroke + dimension "Z"

Please note:

To avoid multiple actuation of magnetic switches, the second piston is not equipped with magnets.

\* Piston with magnet

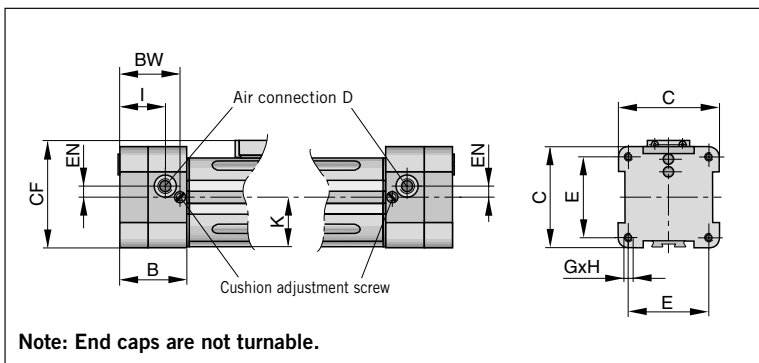
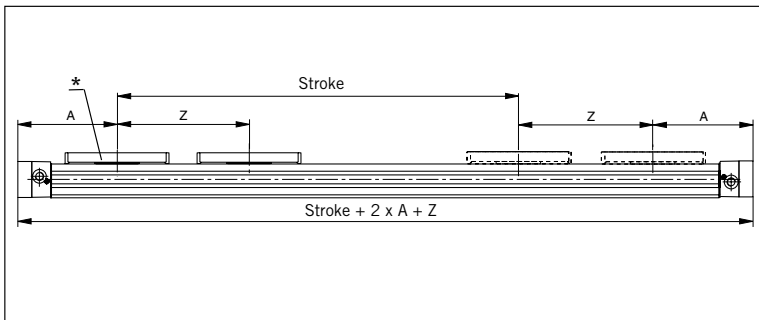

### Carrier Series OSP-P50LS to P80LS

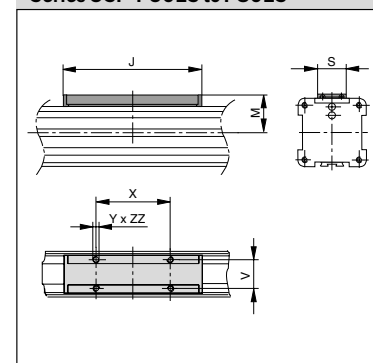

### Dimension Table [mm]

Series	A	B	C	D	E	G	H	I	J	K	M	S	V	X	Y	Z <sub>min</sub>	BW	CF	EN	FB	FH	ZZ
OSP-P50LS	200	58	87	G1/4	70	M6	15	39.5	200	43	49	36	27	110	M6	251	52	92.5	10	76	77	10
OSP-P63LS	250	73	106	G3/8	78	M8	21	49.5	256	54	63	50	34	140	M8	313	65	117	12	96	96	16
OSP-P80LS	295	82	132	G1/2	96	M10	25	57	348	67	80	52	36	190	M10	384	72.5	147	16.5	122	122	20

The right to introduce technical modifications is reserved

# Linear Drive Accessories

## Ø 50-80 mm

### Mid-Section Support E1, E1L



For linear drive  
• Series OSP-P..LS

Note on Types E1 and E1L (P50LS – P80LS):

The mid-section support can also be mounted on the underside of the actuator, in which case its distance from the centre of the actuator is different.

For mounting the Long-Stroke cylinder, a mid-section support Type E1 (fixed support) is required. Depending on the stroke length and the load, additional E1L supports (movable supports) may be required.

For permissible support spacings see diagram.

Stainless steel version on request.



Permissible Support Spacings: OSP - P50LS to P80LS

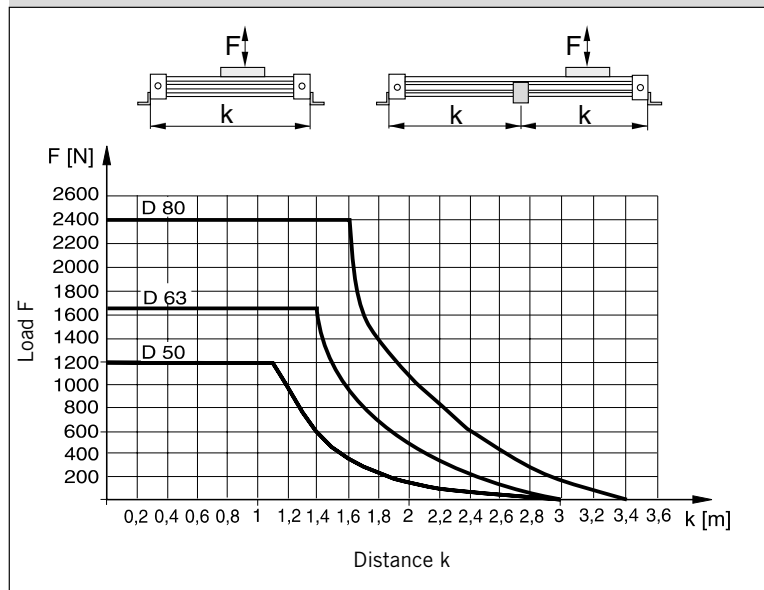

Series OSP-P50LS to P80LS: Type E1, E1L  
(Mounting from above / below using a cap screw)

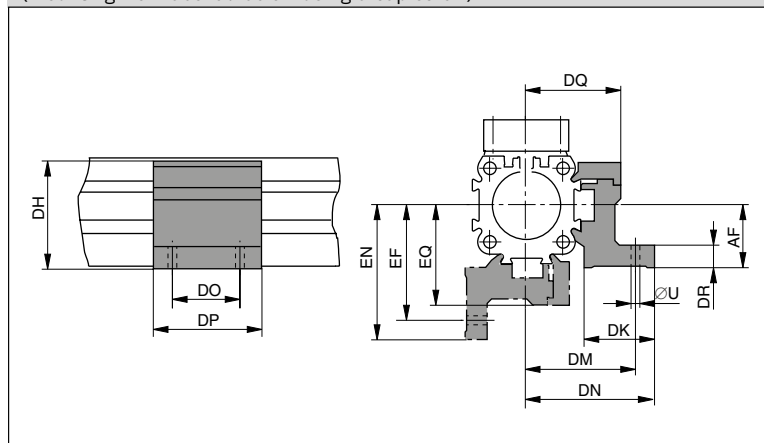

Dimension Table [mm] Series OSP-P50LS to P80LS

Series	R	U	AF	DF	DH	DK	DM	DN	DO	DP
OSP-P50LS	M6	7	48	40	71	34	59	67	45	60
OSP-P63LS	M8	9	57	47.5	91	44	73	83	45	65
OSP-P80LS	M10	11	72	60	111.5	63	97	112	55	80

Series	DQ	DR	DT	EF	EM	EN	EQ	Order No. Type E1 fixed support	Order No. Type E1L movable support
OSP-P50LS	52	10	11	64	45	72	57	20163FIL	21352FIL
OSP-P63LS	63	12	16	79	53.5	89	69	20452FIL	21353FIL
OSP-P80LS	81	15	25	103	66	118	87	20482FIL	21354FIL

## Order Instructions – Long-Stroke Cylinder

**Note:**

Assembly and commissioning of the Long-Stroke cylinder is carried out on site by ORIGA technical personnel.

For more information on ordering and installation please contact your sales or customer service partner.

**Accessories - please order separately**

Description	Further information see
Clevis Mounting	Page 104
End Cap Mountings	Page 105
Mid-Section Support	Page 28
Inversion Mounting	Page 117
Adaptor Profile	Page 118
T-Slot Profile	Page 119
Connection Profile	Page 120
Magnetic Switches	Page 123-126
Cable Cover	Page 127



Characteristics		Pressure quoted as gauge pressure	
Characteristics	Symbol	Unit	Description
<b>General features</b>			
Type			Rodless cylinder
Series			OSP-P
System			doppeltwirkend mit Dämpfung, für berührungslose Positionserfassung
Mounting			see drawings
Air connection			Gewinde
Ambient and medium temperature range	$T_{min}$ $T_{max}$	°C °C	- 10 + 80 other temperatures ranges on request  In case of high temperature fluctuations - please contact our product support.
Weight (mass)		kg	see table below
Installation			in any position
Medium			Filtered, unlubricated compressed (other media on request)
Lubrication			Permanent grease lubrication (additional oil mist lubrication not required) Option: special slow speed grease
Material	Cylinder profile		Anodized aluminium
	Carrier (piston)		Anodized aluminium
	End caps		Aluminium, lacquered
	Sealing bands		Corrosion resistant steel
	Seals		NBR (Option: Viton®)
	Screws		Stainless steel
	Covers		Anodized aluminium
	Guide plate		Plastic
Max. operating pressure*	$P_{max}$	bar	8

\*Pressure quoted as gauge pressure

Weight (mass) [kg]		
Series (basic cylinder)	Weight (mass) [kg]	
	at 0 mm stroke	per 100 mm stroke
OSP-P16	0.22	0.1
OSP-P25	0.65	0.197
OSP-P32	1.44	0.354

#### Size Comparison

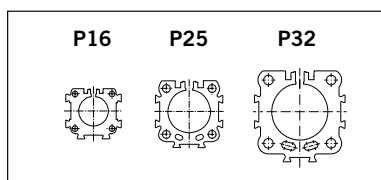

For **magnetic switches** see from page 123  
For **mountings and accessories** see from page 101-122

# Clean Room Cylinder

∅ 16 – 32 mm

## Rodless Cylinder

certified to  
**DIN EN ISO 14644-1**



#### Standard Versions:

- Double-acting with adjustable end cushioning
- With magnetic piston for position sensing
- Stainless steel screws

#### Special Versions:

- Slow speed lubrication
- Viton® seals

#### Series OSP-P..

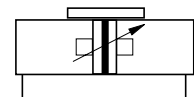

#### Features:

- Clean room classification  
ISO Class 4 at  $v_m = 0.14$  m/s  
ISO Class 5 at  $v_m = 0.5$  m/s
- suitable for smooth slow speed operation up to  $v_{min} = 0.005$  m/s
- optional stroke length up to 1200 mm (longer strokes on request)
- Low maintenance
- Compact design with equal force and velocity in both directions
- Aluminium piston with bearing rings to support high direct and cantilever loads



The right to introduce technical modifications is reserved

### Certification

Based on the Parker Origa rodless cylinder, proven in world wide markets, Parker Origa now offers the only rodless cylinder on the market with a certification from IPA Institute for the cleanroom specification according to DIN EN ISO 14644-1.



### Function:

The clean room cylinders of the ORIGA SYSTEM PLUS (OSP-P) combines the efficiency of the Parker Origa slot seal system with vacuum protection against progressive wear and contamination from the sliding components. A partial vacuum drawn between inner and outer sealing bands prevents emission into the clean room. To achieve the necessary vacuum a suction flow of ca. 4 m<sup>3</sup>/h is required.

### Function Diagram

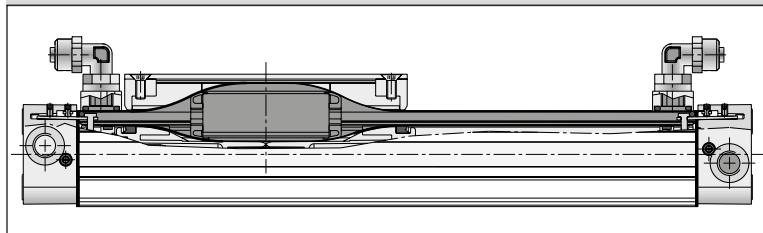

### Loads, Forces and Moments

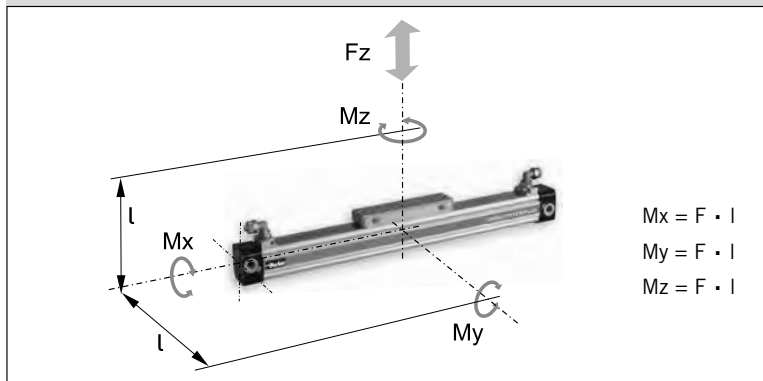

Series	Effective Force at 6 bar [N]	Max. Moment			Max. Load Fz [N]	Cushion Length [mm]
		Mx [Nm]	My [Nm]	Mz [Nm]		
OSP-P16	78	0.45	4	0.5	120	11
OSP-P25	250	1.5	15	3.0	300	17
OSP-P32	420	3.0	30	5.0	450	20

Load and moment data are based on speeds  $v \leq 0.2$  m/s. The adjacent table shows the maximum values for light, shock-free operation which must not be exceeded even in dynamic operation.

**Dimensions [mm]**

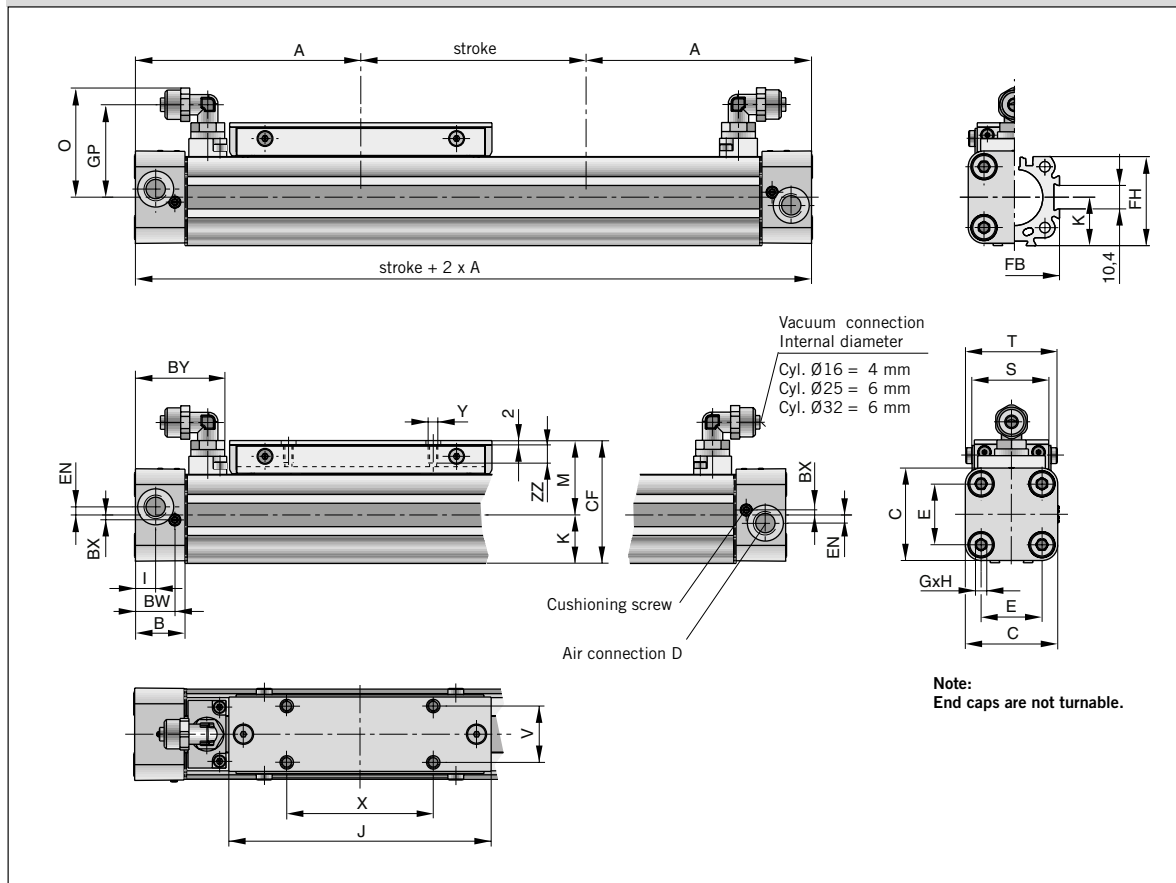

**Dimension Table [mm]**

Series	A	B	C	D	E	G	H	I	J	K	M	O	S
OSP-P16	65	14	30	M5	18	M3	9	5.5	69	15	25	31	24
OSP-P25	100	22	41	G1/8	27	M5	15	9	117	21.5	33	48.5	35
OSP-P32	125	25.5	52	G1/4	36	M6	15	11.5	152	28.5	40	53.6	38

Series	T	V	X	Y	BW	BX	BY	CF	EN	FB	FH	GP	ZZ
OSP-P16	29.6	16.5	36	M4	10.8	1.8	28.5	40	3	30	27.2	25.7	7
OSP-P25	40.6	25	65	M5	17.5	2.2	40.5	54.5	3.6	40	39.5	41	8
OSP-P32	45	27	90	M6	20.5	2.5	47.1	68.5	5.5	52	51.7	46.2	10

The right to introduce technical modifications is reserved

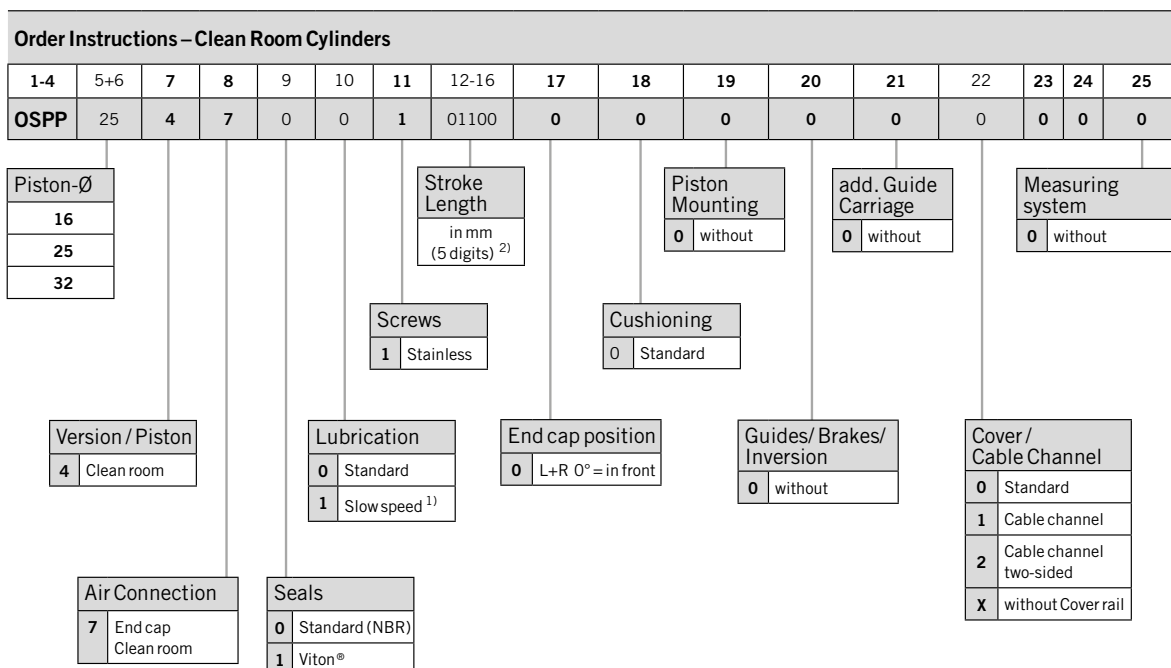

<sup>1)</sup> The combination „Slow speed lubrication“ and „Viton® sealings“ are available on request.

<sup>2)</sup> max. stroke lengths 1200 mm, longer strokes on request.

**Accessories – please order separately**

Description	Further information see
End Cap Mountings	Page 105
Mid-Section Support	Page 106
Adaptor Profile	Page 118
T-Slot Profile	Page 119
Connection Profile	Page 120
Magnetic Switches	Page 123-126

### Information for ATEX-Directives

The rodless pneumatic cylinders of Parker Origa are the first linear drive unit, for that Ex range in the group of equipment II, Category 2 GD are certified.

Detailed information for use pneumatic components in Ex-Areas see leaflet PDE2584TCUK "EU Directive 2014/34/EU for Pneumatic Components".



### Technical Data (deviant to the Standard Cylinder)

Pressure quoted as gauge pressure

Characteristics	Symbol	Unit	Description
Ambient temperature range	$T_{min}$ $T_{max}$	°C °C	-10 +60
Max. switching frequency		Hz	1 (double stroke/s) Basic cylinder 0.5 (1stroke/s) Cylinder with guide
Operating pressure range	$p_{max}$	bar	8
Max. speed	$v_{max}$	m/s	3 (Basic cylinder) 2 (Cylinder with guide SLIDELINE and cylinder with guide BASIC GUIDE)
Medium			Filtered, unlubricated compressed air – free from water and dirt to ISO 8573-1 Solids: Class 7 particle size < 40 µm for Gas Water content: pressure dew point +3 °C, class 4, but at least 5 °C below minimum operating temperature
Noise level		dB (A)	70
Information for materials			Aluminium: see data sheet "Material" Lubrication: see security data sheet "Grease for use in Cylinder with guides" Sealing bands: Corrosion resistant steel

For all other details for dimensions, weights, allowable loads, cushioning diagrams and accessories see data sheets in this catalogue.

### Equipment Group II Categorie 2GD

Rodless cylinder:  $\text{Ex II 2GDc T4 T135}^{\circ}\text{C} - 10^{\circ}\text{C} \leq T_a \leq +60^{\circ}\text{C}$

Series	Size	Stroke range	Accessories
OSP-P	Ø 10 to 80	1–6000 mm	Mountings programme
BASIC GUIDE	Ø 25 to 50	1–6000 mm	Mountings programme
SLIDELINE	Ø 16 to 80	1–5500 mm	Mountings programme

For **basic cylinder** see page 15-24  
 For **BASIC GUIDE** see page 39-45  
 For **plain bearing guide SLIDELINE** see page 49-50  
 For **mountings and accessories** see page 101-120

## Components for EX-Areas

**OSP**  
ORIGA  
SYSTEM  
PLUS

### Rodless Cylinder Ø 10 – 80 mm Basic Cylinder

Series: OSP-P ..ATEX

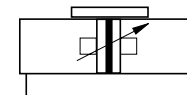

### BASIC GUIDE Ø 25 – 50 mm

Series: BG -..ATEX



### Plain Bearing Guide SLIDELINE Ø 16 – 80 mm

Series: SL -..ATEX



The right to introduce technical modifications is reserved

**Order Instructions – ATEX-CYLINDER \***

1-4	5+6	7	8	9	10	11	12-16	17	18	19	20	21	22	23	24	25
OSPP	25	6	0	0	0	0	01100	0	0	0	0	0	0	0	0	0

Piston-Ø
10
16
25
32
40
50
63
80

Stroke
Input in mm (5 digits)

Piston Mounting
0 without
1 clevis mounting Ø 16-80

add. Guide Carriage
0 without
2 Guide Carriage Slideline SL Ø 16-80

Measuring system
0 without

Screws
0 standard
1 Stainless

Cushioning
0 standard
1 max. length <sup>2)</sup>

Version / Piston
* 6 ATEXstandard

Lubrication
0 standard
1 Slow speed <sup>1) 2)</sup>

End cap position
0 L + R 0° = in front
1 L + R 90° = underneath
2 L + R 180° = at the back
3 L + R 270° = same side as outerband
4 L 90° = underneath; R 0° = in front
5 L 180° = at the back; R 0° = in front
6 L 270° = same side as outerband; R 0° = in front
7 L 0° = in front; R 90° = underneath
8 L 180° = at the back; R 90° = underneath
9 L 270° = same side as outerband; R 90° = underneath
A L 0° = in front; R 180° = at the back
B L 90° = underneath; R 180° = at the back
C L 270° = same side as outerband; R 180° = at the back
D L 0° = in front; R 270° = same side as outerband
E L 90° = underneath; R 270° = same side as outerband
F L 180° = at the back; R 270° = same side as outerband

Guides/ Brakes/ Inversion
0 without
2 Slideline SL Ø 16-80
M Inversion

Cover / Cable Channel
0 standard
1 Cable channel
2 Cable channel two-sided
X without cover rail

Air Connection
0 Standard
1 end face
2 both at one end (not turnable)
3 left stand. right end face
4 right stand. left end face

Seals
0 standard (NBR)
1 Viton® <sup>1)</sup>

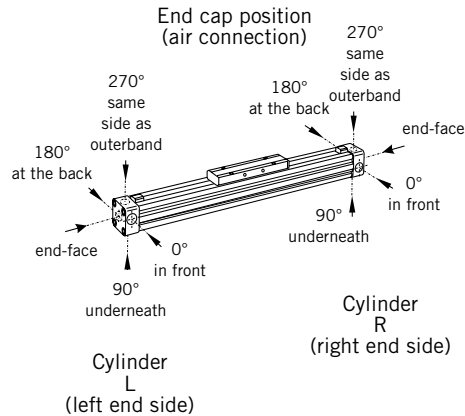

\* Order instructions BASIC GUIDE ATEX-Version see page 45

<sup>1)</sup> Slow speed lubrication in combination with Viton® seals on demand.

<sup>2)</sup> „Lubrication slow speed“ in combination with „max. cushioning length“ not possible.

**Accessories – please order separately**

Description	Further information see
End Cap Mounting for OSP-P Basic Cylinder	Page 105
End Cap Mounting for OSP-P Basic Cylinder with SLIDELINE	Page 108
Mid-Section Support for OSP-P Basic Cylinder	Page 106
Mid-Section Support for OSP-P Basic Cylinder with SLIDELINE	Page 109
Adaptor Profile	Page 118
T-Slot Profile	Page 119
Connection Profile	Page 120
Magnetic Switches ATEX-Version	on request

Characteristics				Pressure quoted as gauge pressure			
Characteristics	Symbol	Unit	Description				
<b>General Features</b>							
Type			Rodless cylinder for synchronized bi-parting movements				
Series			OSP-P				
System			Double acting with end cushioning For contactless position sensing				
Guide			Slideline SL40				
Synchronization			Toothed belt				
Mounting			See drawings				
Ambient temperature range	$T_{min}$ $T_{max}$	°C °C	-10 +60				
Weight (mass)		kg	see page 38				
Medium			Filtered, unlubricated compressed air (other media on request)				
Lubrication			Special slow speed grease – additional oil mist lubrication not required				
Material							
Toothed Belt			Steel-corded polyurethane				
Belt wheel			Aluminium				
Operating pressure range	$p_{max}$	bar	6				
Cushioning middle position			Elastic buffer				
Max. Speed	$v_{max}$	m/s	0.2				
Max. stroke of each stroke		mm	500				
Max. mass per guide carrier		kg	25				
Max. moments on guide carrier							
lateral moment	$Mx_{max}$	Nm	25				
axial moment	$My_{max}$	Nm	46				
rotating moment	$Mz_{max}$	Nm	46				
<b>For more technical information see page 15-17,19 and 49-50</b>							

# Rodless Cylinder Ø 40 mm

for synchronized  
bi-parting movements

Type OSP-P40-SL-BP



### Features:

- Accurate bi-parting movement through toothed belt synchronization
- Optimum slow speed performance
- Increased action force
- Anodized aluminium guide rail with prism-form slideway arrangement
- Adjustable polymer slide units
- Combined sealing system with polymer and felt elements to remove dirt and lubricate the slideway
- Integrated grease nipples for guide lubrication

### Applications:

- Opening and closing operations
- Gripping of workpieces – outside
- Gripping of hollow workpieces – inside
- Gripping underneath larger objects
- Clamping force adjustable via pressure regulator

### Applications

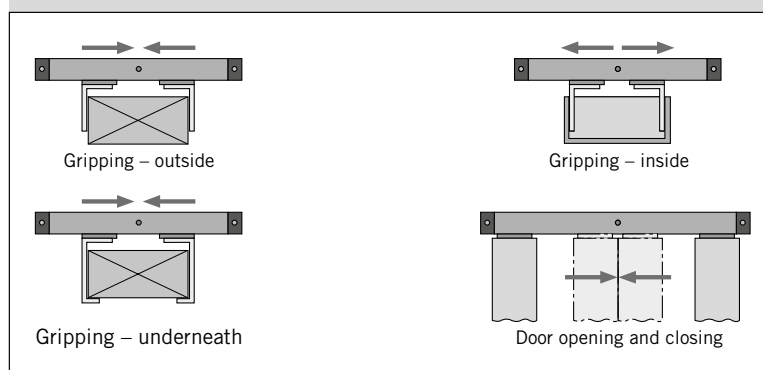

For **Magnetic Switches** see page 123-126



The right to introduce technical modifications is reserved

Weight (mass) [kg]		
Cylinder series (Basic cylinder)	Weight (mass) [kg]	
	At 0 mm stroke	per 100 mm stroke
OSP-P40-SL-BP	10.33	2.13

**Function:**

The OSP-P40-SL-BP bidirectional linear drive is based on the OSP-P40 rodless pneumatic cylinder and adapted SLIDELINE SL40 polymer plain-bearing guides.

Two pistons in the cylinder bore are connected via yokes and carriers to the SLIDELINE guide carriers, which handle the forces and moments generated.

The bi-parting movements of the guide carriers are accurately synchronized by a recirculating toothed belt.

The two pistons are driven from the middle to the end positions via a common G1/4 air connection in the middle of the cylinder, and are driven from the end positions to the middle via an air connection in each end cap.

End position cushioning is provided by adjustable air cushioning in the end caps, and middle position cushioning by rubber buffers.

**Dimensions [mm]**

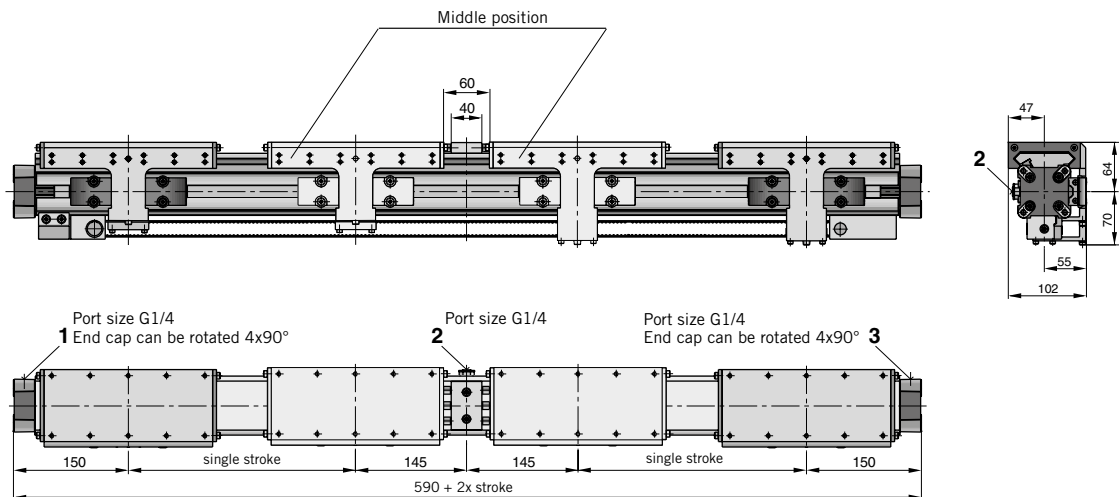

**Air connections:**

To drive the guide carriers to the middle position: pressurize ports 1 and 3.

To drive the guide carriers to the end positions: pressurize port 2.

For more dimensions see page 15-17, 19 and 49-50

**Order Instructions**

Description	Type	Order No. **
Rodless cylinder for synchronized bi-parting movements	OSP-P40-SL-BP	21315

**Note:** Order stroke = 2 x single stroke

\*\* Please use this order pattern: Order-No. + „order stroke in mm“ (5 digits)

Example: for single stroke 100 mm = order stroke 2x100 mm = 200mm: 21315-00200

Characteristics		Pressure quoted as gauge pressure	
Characteristics	Symbol	Unit	Description
<b>General features</b>			
Type			Rodless Cylinder
Series			OSPP-BG
System			Double-acting, with cushioning, position sensing capability
Mounting			see drawings
Air connection			Threaded
Ambient and medium temperature range	$T_{min}$ $T_{max}$	°C °C	- 10 + 80   other temperatures ranges on request  In case of high temperature fluctuations - please contact our product support.
Weight (mass)		kg	see table below
Installation			in any position
Medium			Filtered, unlubricated compressed (other media on request)
Lubrication			Permanent grease lubrication (additional oil mist lubrication not required) Option: special slow speed grease
Material	Cylinder profile		Anodized aluminium
	Carrier (piston)		Anodized aluminium
	End caps		Al, catalytically coated
	Sealing bands		Corrosion resistant steel
	Seals		NBR (Option: Viton®)
	Screws		Stainless steel Option: stainless steel
	Dust covers, wipers		Plastic
Max. operating pressure*	$P_{max}$	bar	8

Weight (mass) [kg]		
Cylinder series (basic cylinder)	Weight (mass) [kg]	
	at 0 mm stroke	per 100 mm stroke
OSPP-BG25	1.09	0.22
OSPP-BG32	2.26	0.38
OSPP-BG40	3.52	0.41
OSPP-BG50	5.30	0.58

Size Comparison				
BG25	BG32	BG40	BG50	

For **Magnetic Switches** see page 123-126

# Plain Bearing BASIC GUIDE

∅ 25 - 50 mm



Series OSPP-BG

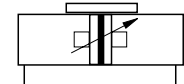

### Standard Versions:

- Double-acting with adjustable end cushioning
- With magnetic piston for position sensing

### Special Versions:

- Stainless steel screws
- Slow speed lubrication
- Viton® seals
- Both air connections on one end
- Air connection on the end-face
- Integrated Valves VOE



- End cap can be rotated 4 x 90° to position air connection as desired
- Free choice of stroke length: BG25 and BG32 up to 9640 mm BG40 and BG50 up to 5600 mm

(longer strokes on request)

The right to introduce technical modifications is reserved

# Plain Bearing BASIC GUIDE



Size BG 25 to 50  
Compact, robust plain bearing guide  
for medium loads  
• Series OSP-P

### Features:

- Compact: guide rail integrated in cylinder profile tube
- Robust: wiper system and grease nipples for long service life
- smooth operation
- simple to (re-) adjust
- Integrated grease nipples
- Variable stroke length:  
BG25 and BG32 up to 9640 mm  
BG40 and BG50 up to 5600 mm  
(longer strokes on request)

### Options:

- Corrosion resistant version available on request
- VOE-Valves
- ATEX-version (see page 35-36)

### Accessories:

- Mid-Section Support
- End Cap Mountings
- Magnetic Switches

### Versions

#### Pneumatic linear drive Series OSPP-BG

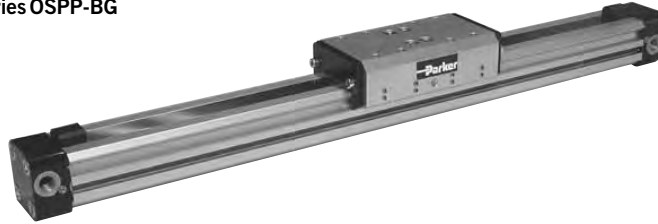

Composite sealing system with high-tech polymer and felt wiper elements to remove dirt and lubricate the slideways.

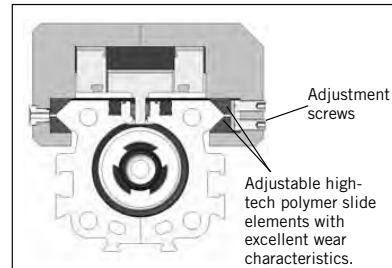
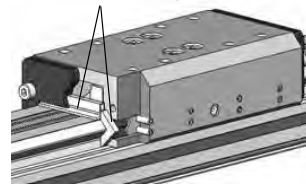

### Loads, Forces and Moments

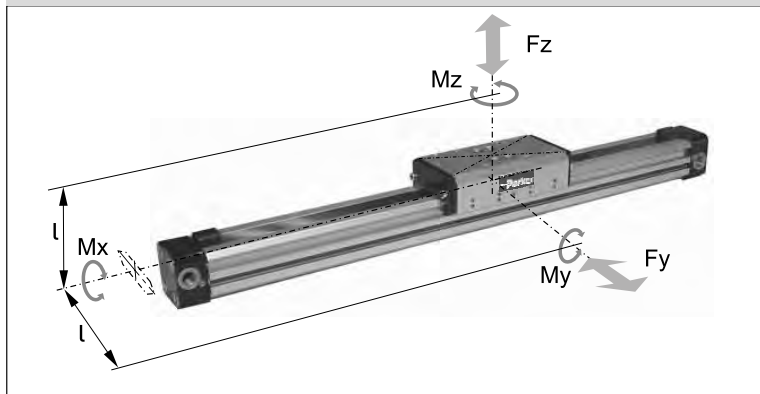

### Technical Data

The table shows the maximum permissible values for smooth operation, which should not be exceeded even under dynamic conditions.

The load and moment gures apply to speeds  $v < 0.2$  m/s.

### \* Please note:

In the cushioning diagram, add the mass of the guide carriage to the mass to be cushioned.

$$\frac{M_x}{M_{x_{max}}} + \frac{M_y}{M_{y_{max}}} + \frac{M_z}{M_{z_{max}}} + \frac{F_y}{F_{y_{max}}} + \frac{F_z}{F_{z_{max}}} \leq 1$$

The sum of the loads should not exceed 1.

Series	Max. Moments [Nm]			Max. Load [Nm] F <sub>y</sub> , F <sub>z</sub>	Mass of Basic Guide [kg]		Mass * of guide carriage [kg]	Cushion Length [mm]
	M <sub>x</sub>	M <sub>y</sub>	M <sub>z</sub>		at 0 mm stroke	per 100 mm stroke		
<b>BG25</b>	10	28	28	590	1.09	0.22	0.29	17
<b>BG32</b>	17	43	43	850	2.26	0.38	0.69	20
<b>BG40</b>	39	110	110	1600	3.52	0.41	1.37	27
<b>BG50</b>	67	165	165	2000	5.30	0.58	1.91	30

Mountings see page 44

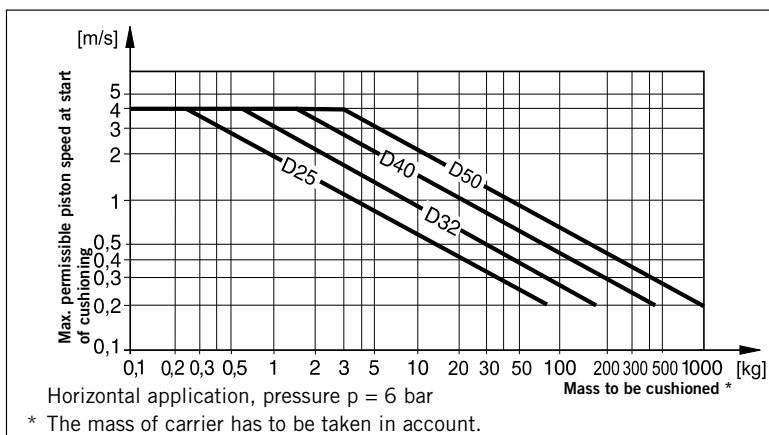

### Cushioning Diagram

Work out your expected moving mass and read off the maximum permissible speed at start of cushioning. Alternatively, take your desired speed and expected mass and find the cylinder size required.

Please note that piston speed at start of cushioning is typically approx.

50 % higher than the average speed, and that it is this higher speed which determines the choice of cylinder.

**If the permitted limit values are exceeded, additional shock absorbers should be fitted in the area of the centre of gravity.**

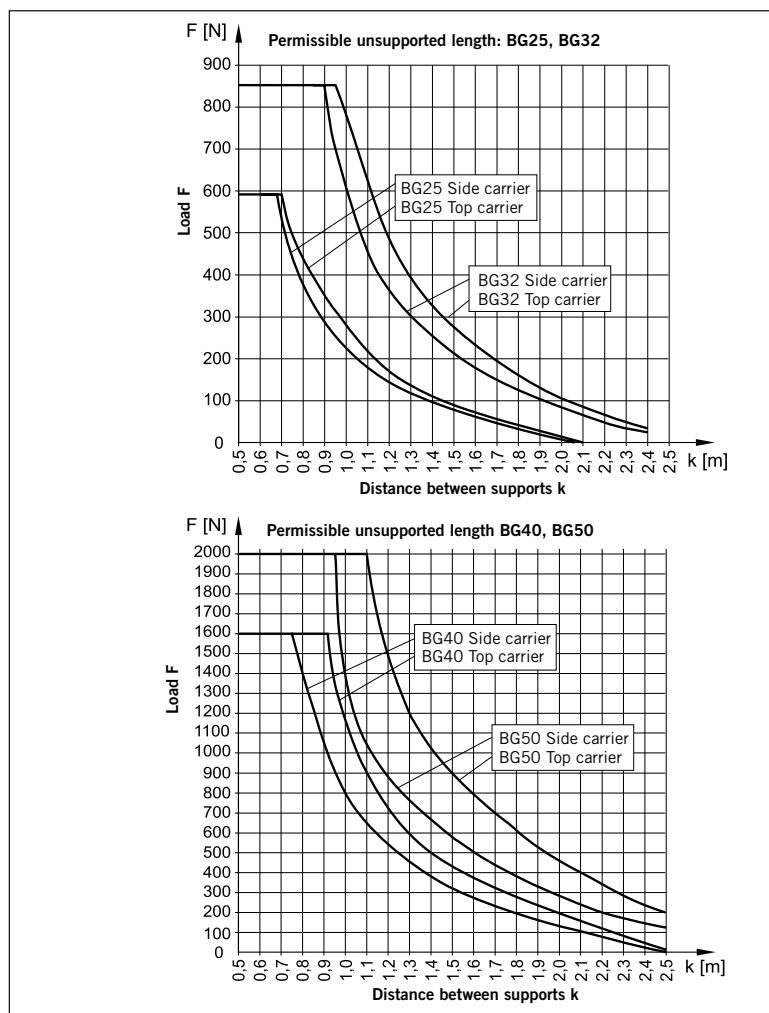

### Mid-Section Support

(Versions see page 44)

Mid-section supports are required from a certain stroke length to prevent excessive deflection and vibration of the linear drive.

The diagrams show the maximum permissible unsupported length in relation to loading. A distinction must be drawn between loading 1 and loading 2.

Deflection of 0.5 mm max. between supports is permissible.

**Note:**

For speeds  $v > 0.5$  m/s the distance between supports should not exceed 1 m.

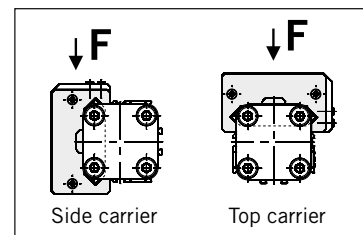
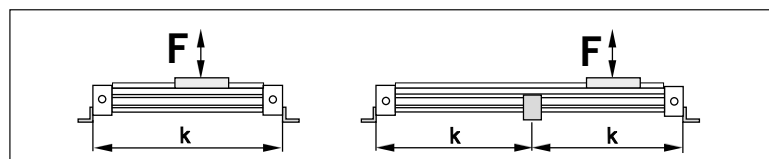

The right to introduce technical modifications is reserved

## Cylinder Stroke and Dead Length A

- Variable stroke length in 1 mm steps:  
BG25 and BG32 up to 9640 mm  
BG40 and BG50 up to 5600 mm  
(longer strokes on request)

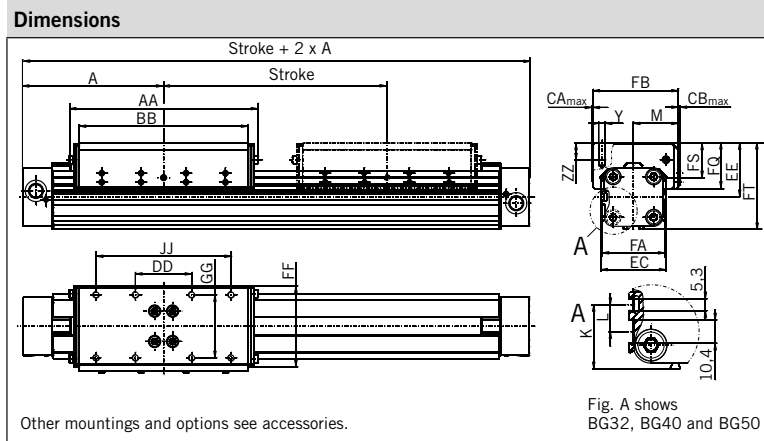

## Tandem Cylinder

Two pistons are fitted: dimension "Z" is optional.  
(Please note minimum distance  $Z_{min}$ ).

- Variable stroke length in 1 mm steps:  
BG25 and BG32 up to 9440 mm  
BG40 and BG50 up to 5300 mm  
(longer strokes on request)
- **Stroke length to order is stroke + dimension "Z"**

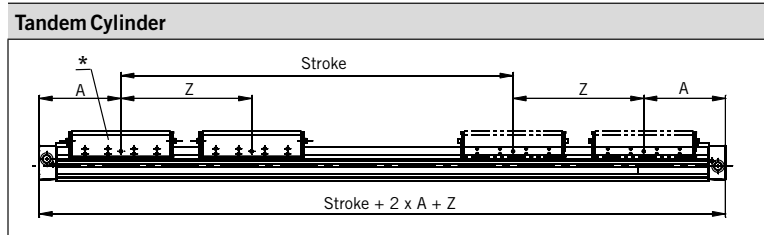

Please note:

To avoid multiple actuation of magnetic switches, the second piston is not equipped with magnets.

## Standard air connection

End cap can be rotated 4 x 90°. The air connection and cushion screw can therefore be positioned as desired.

\* piston with magnet

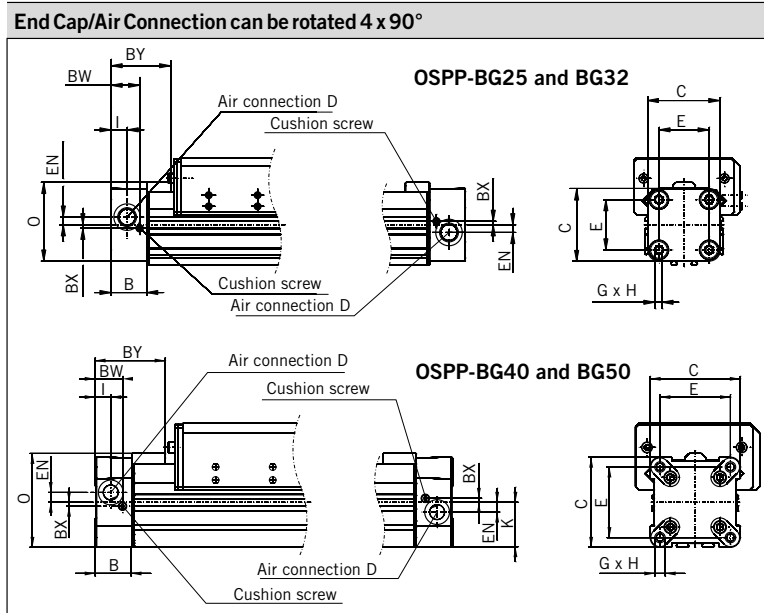

Dimension Table [mm]																	
Series	A	B	C	D	E	G	H	I	K	L	M	O	Y	Z <sub>min</sub>	AA	BB	BW
<b>BG25</b>	100	22	41	G1/8	27	M5	15	9	17.5	-	32	47	M6	128	126	108	17.5
<b>BG32</b>	125	25.5	52	G1/4	36	M6	15	11.5	28.5	12	40	59	M6	170	168	150	20.5
<b>BG40</b>	150	28	69	G1/4	54	M6	15	12	34.5	12	47	72	M6	212	198	178	21
<b>BG50</b>	175	33	87	G1/4	70	M6	15	14.5	43.5	12	54	86	M6	251	240	220	27
Series	BX	BY	CA <sub>max</sub>	CB <sub>max</sub>	DD	EC	EE	EN	FA	FB	FF	FQ	FS	FT	GG	JJ	ZZ
<b>BG25</b>	2.2	40	1.5	1.5	40	44	38	3.6	44	60	56	32	24	59.5	43	80	12
<b>BG32</b>	2.5	44	0	2	50	58	48	5.5	56	76	72	40.8	30.8	76.5	56	120	12
<b>BG40</b>	3	54	0	1	70	67	58	7.5	67	89	84	48	36	92.5	60	140	12
<b>BG50</b>	-	59	0	0	100	77.5	63	11	80	101	94	49	36	106.5	78	200	12

**End cap - Air connection both at one end**  
Series OSPP-BG 25

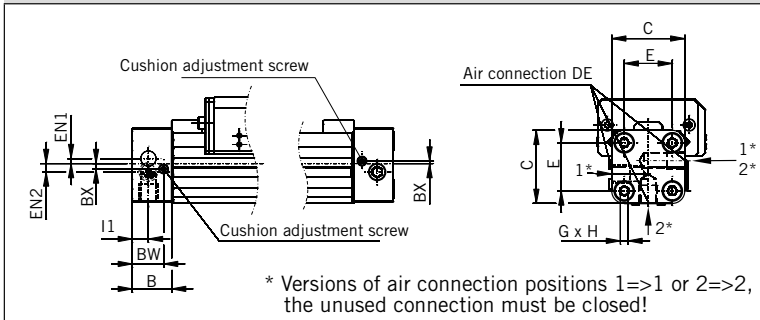

**Both Air Connections at One End**

A special end cap with both air connections on one side is available for situations where shortage of space, simplicity of installation or the nature of the process make it desirable. Air supply to the other end is given via internal air passages.

**In this case the end caps cannot be rotated.**

**End cap - Air connection both at one end**  
Series OSPP-BG32 to BG50

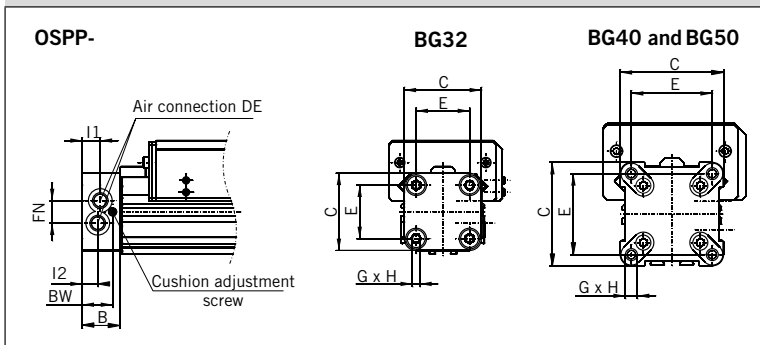

**End cap - Air connection on the End-face**  
Series OSPP-BG25 to BG50

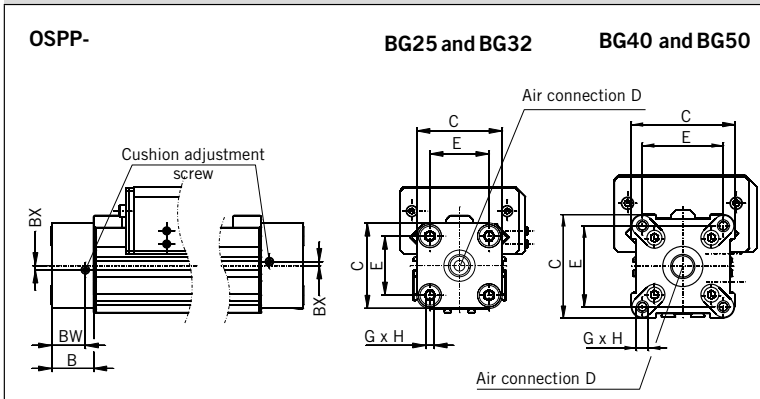

**Air Connection on the End-face**

In some situations it is necessary or desirable to fit a special end cap with the air connection on the end-face instead of the standard end cap with the air connection on the side.

The special end cap can also be rotated 4 x 90° to locate the cushion adjustment screw as desired.

Supplied in pairs.

**Dimension Table [mm]**

Series	B	C	D	DE	E	G	H	BW	BX	BY	EN1	EN2	FN	I1	I2
<b>BG25</b>	22	41	G1/8	G1/8	27	M5	15	17.5	2.2	40	3.6	3.9	-	9	-
<b>BG32</b>	25.5	52	G1/4	G1/8	36	M6	15	20.5	2.5	44	-	-	15.2	12.2	10.5
<b>BG40</b>	28	69	G1/4	G1/8	54	M6	15	21	3	54	-	-	17	12	12
<b>BG50</b>	33	87	G1/4	G1/4	70	M6	15	27	-	59	-	-	22	14.5	14.5

The right to introduce technical modifications is reserved

# Linear Drive Accessories

## ∅ 25-50 mm

### End Cap Mountings



For linear drive  
• Series OSPP-BG

On the end-face of each cylinder end cap there are four threaded holes for mounting the cylinder. The hole layout is square, so that the mounting can be fitted to the bottom, top or either side.

The air connection can still be positioned as desired.



### Mid-Section Support

For linear drive  
• Series OSPP-BG

For permissible support spacings see diagram page 41.

Stainless steel version on request.



Series OSPP-BG25 and BG32: Type A1 (Supplied in pairs)

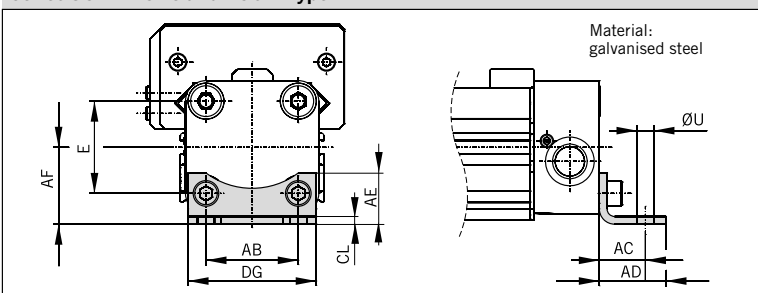

Series OSPP-BG40 and BG50: Type C1 (Supplied in pairs)

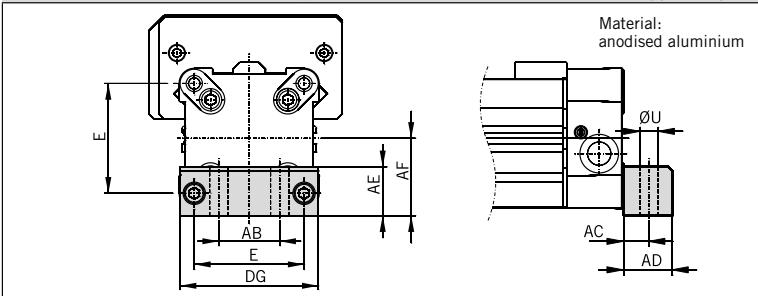

Series OSPP-BG25 to BG50: Type E1BG

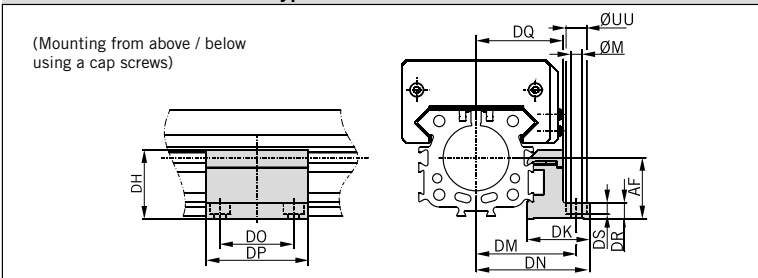

Series OSPP-BG25 to BG50: Type D1BG

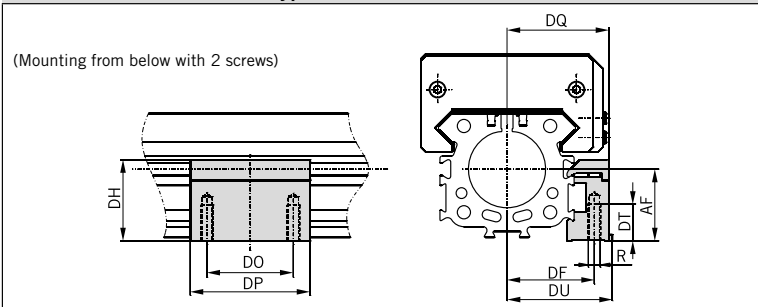

Dimension Table [mm]												
Series	E	R	∅U	∅M	AB	AC	AD	AE	AF	CL	DF	DG
BG25	27	M5	5.8	5.5	27	16	22	18	22	2.5	29	39
BG32	36	M5	6.6	5.5	36	18	26	20	30	3	36.5	50
BG40	54	M6	9	7	30	12.5	24	24	38	-	39	68
BG50	70	M6	9	7	40	12.5	24	30	48	-	45.5	86

Series	DH	DK	DM	DN	DO	DP	DQ	DR	DS	DT	DU	∅UU	Ident-No.			
													Type A1*	Type C1*	Type E1BG	Type D1BG
BG25	20	30.5	42	49.5	36	50	35	8	5.7	15	36.5	10	2010FIL	-	21482FIL	21483FIL
BG32	34	30.5	49	55.5	36	50	42.5	8	5.7	15	42.5	10	3010FIL	-	21487FIL	21488FIL
BG40	43	34	56	63	45	60	48	10	-	11	48	-	-	4010FIL	21510FIL	21511FIL
BG50	56	34	62.5	69.5	45	60	54	23	-	11	54.5	-	-	5010FIL	21594FIL	21593FIL

\* = Pair

Order Instructions – BASIC GUIDE														
1-6	7+8	9	10	11	12	13	14-18	19	20	21	22	23	24	25
OSPPBG	25	0	0	0	0	0	01100	0	0	0	0	0	0	0

Piston-Ø
25
32
40
50

Stroke
Input in mm (5 digits)

Piston Mounting
0 without

Cover / Cable Channel
0 standard
1 cable channel dove tail Ø 32, 40, 50
2 cable channel dove tail two-sided Ø 32, 40, 50

Version / Piston
0 Standard
1 Tandem
* 6 ATEX Standard <sup>3)</sup>

Screws
0 standard
1 stainless

Cushioning
0 standard
1 max. length <sup>4)</sup>

Lubrication
0 standard
1 slow speed <sup>2)</sup>

End cap position
0 L + R 0° = in front
1 L + R 90° = underneath
2 L + R 180° = at the back
3 L + R 270° = same side as outerband
4 L 90° = underneath; R 0° = in front
5 L 180° = at the back; R 0° = in front
6 L 270° = same side as outerband; R 0° = in front
7 L 0° = in front; R 90° = underneath
8 L 180° = at the back; R 90° = underneath
9 L 270° = same side as outerband; R 90° = underneath
A L 0° = in front; R 180° = at the back
B L 90° = underneath; R 180° = at the back
C L 270° = same side as outerband; R 180° = at the back
D L 0° = in front; R 270° = same side as outerband
E L 90° = underneath; R 270° = same side as outerband
F L 180° = at the back; R 270° = same side as outerband

Air Connection
0 standard
1 on the end face
2 both at one end (not turnable)
3 left standard right end face
4 right standard left end face
A 3/2 way valve VOE 24 V = Ø 25, 32, 40, 50
B 3/2 way valve VOE 230 V~/110 V = Ø 25, 32, 40, 50
C 3/2 way valve VOE 48 V = Ø 25, 32, 40, 50
E 3/2 way valve VOE 110 V~ Ø 25, 32, 40, 50

Seals
0 standard (NBR)
1 Viton <sup>® 1)</sup>

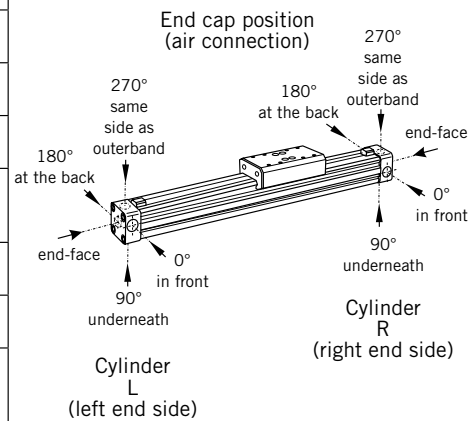

\* for more information ATEX Basic Guide see page 35

- 1) Viton with VOE not possible.
- 2) "Slow speed Lubrication" in combination with „Viton“ seals on demand.
- 3) ATEX with VOE not possible.
- 4) „Lubrication slow speed“ in combination with „max. cushioning length“ not possible.

#### Accessories – please order separately

Description	Further information see
End Cap Mounting	Page 44
Mid-Section Support	Page 44
Magnetic Switches	Page 123

The right to introduce technical modifications is reserved



# Linear Guides Series OSP-P

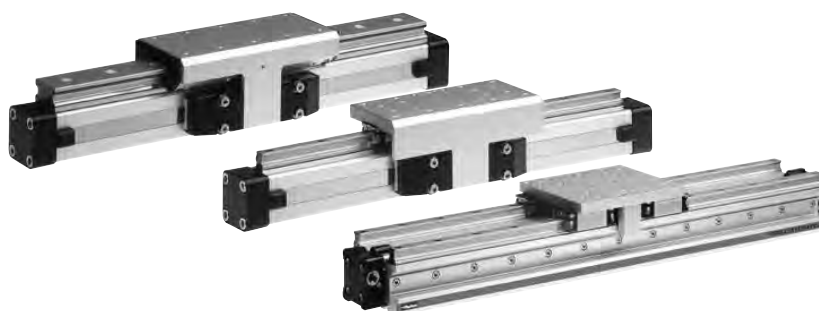

## Contents

Description	Page
Overview	47-48
Plain bearing guide SLIDELINE	49-51
Roller guide POWERSLIDE	53-57
Aluminium roller guide PROLINE	59-61
Recirculating ball bearing guide STARLINE	63-69
Recirculating ball bearing guide KF	71-77
Heavy duty guide HD	79-86

The right to introduce technical modifications is reserved

# OSP

— ORIGA  
— SYSTEM  
— PLUS

## Adaptive modular system

The Origa system plus – OSP – provides a comprehensive range of linear guides for the pneumatic and electric linear drives.

### Advantages:

- Takes high loads and forces
- High precision
- Smooth operation
- Can be retrofitted
- Can be installed in any position

### Rodless Pneumatic Cylinder Series OSP - P

Piston diameters 10 – 80 mm

See

page 15-24 (Standard)

page 35-36 (ATEX-Version)

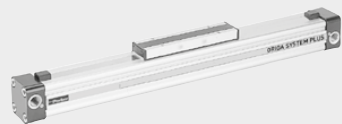

### BASIC GUIDE

Compact, robust plain bearing guide for medium loads.

Piston diameters 25-50 mm

See

page 39-45 (Standard)

page 35-36 (ATEX-Version)



## Linear Guides

### SLIDELINE

The cost-effective plain bearing guide for moderate loads. Active/ Passive Brake optional.

Piston diameters 16 – 80 mm

See Page 49-51 (Standard)

See Page 35-36 (ATEX-Version)

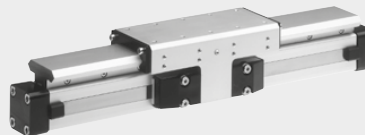

### POWERSLIDE

The roller guide for heavy loads and hard application conditions

Piston diameters 16 – 50 mm

See page 53-57



### PROLINE

The compact aluminium roller guide for high loads and velocities.

Active/ Passive Brake optional.

Piston diameters 16 – 50 mm

See page 59-61

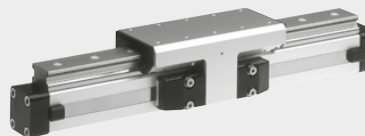

### STARLINE

Recirculating ball bearing guide for very high loads and precision

Piston diameters 16 – 50 mm

See page 63-69

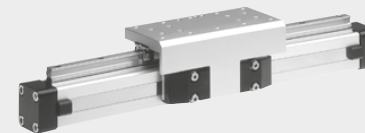

### KF GUIDE

Recirculating ball bearing guide for high loads and precision.

Correspond to FESTO dimensions (Type DGPL-KF)

Piston diameters 16 – 50 mm

See page 71-77

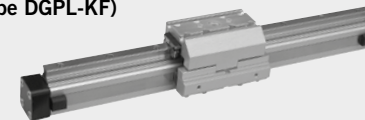

### HD HEAVY DUTY GUIDE

Recirculating ball bearing guide for highest loads and greatest accuracy.

Piston diameters 25 – 50 mm

See page 79-86

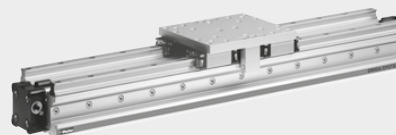

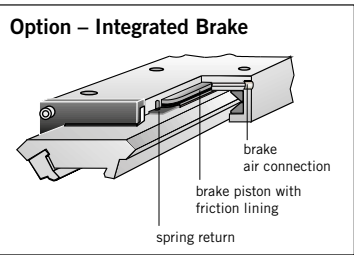
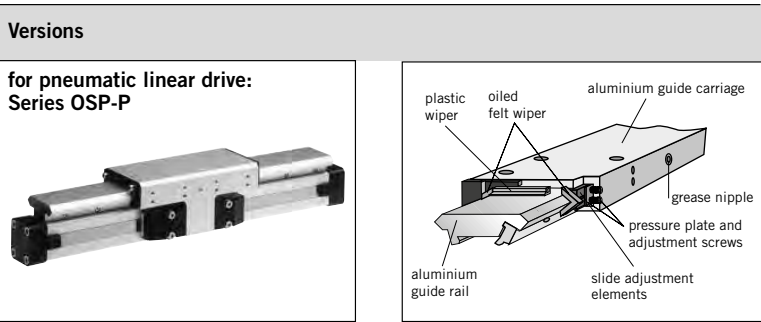

**Integrated Brake (optional)  
for series OSP-P25 to OSP-P50:**

- Actuated by pressure
- Released by exhausting and spring return

For further technical data see also linear drives OSP-P (from page 15)

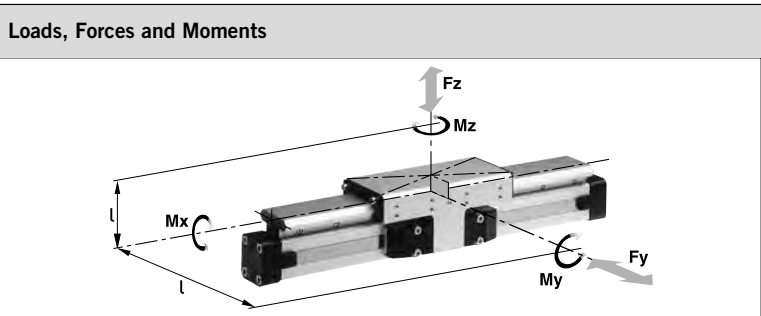

**Technical Data**

The table shows the maximum permissible values for smooth operation, which should not be exceeded even under dynamic conditions.

The load and moment figures apply to speeds  $v < 0.2$  m/s.

**\* Please note:**

In the cushioning diagram, add the mass of the guide carriage to the mass to be cushioned.

# Plain Bearing Guide SLIDELINE



**Series SL 16 to 80  
for Linear-drive**

- Series OSP-P

**Features:**

- ATEX-version (without brake) is also available (see page 35-36)
- Anodised aluminium guide rail with prism-shaped slideway arrangement
- Adjustable plastic slide elements – optional with integral brake
- Composite sealing system with plastic and felt wiper elements to remove dirt and lubricate the slideways
- Corrosion resistant version available on request
- Any length of stroke up to 5500 mm (longer strokes on request)

- 1) Only with integrated brake:  
Braking force on dry oil-free surface  
Values are decreased for lubricated slideways
- 2) Corrosion resistant fixtures available on request

Series	For linear drive	Max. moments [Nm]			Max. loads [N] Fy, Fz	Maximum braking force at 6 bar [N] <sup>1)</sup>	Mass of linear drive with guide [kg]		Mass * of guide carriage [kg]	Order-No. ** SLIDELINE <sup>2)</sup> Guide without cylinder	
		Mx	My	Mz			with 0 mm stroke	increase per 100 mm stroke		without brake	with brake
SL16	OSP-P16	6	11	11	325	-	0.57	0.22	0.23	20341	on request
SL25	OSP-P25	14	34	34	675	325	1.55	0.39	0.61	20342	20409
SL32	OSP-P32	29	60	60	925	545	2.98	0.65	0.95	20196	20410
SL40	OSP-P40	50	110	110	1600	835	4.05	0.78	1.22	20343	20411
SL50	OSP-P50	77	180	180	2000	1200	6.72	0.97	2.06	20195	20412
SL63	OSP-P63	120	260	260	2500	-	11.66	1.47	3.32	20853	-
SL80	OSP-P80	120	260	260	2500	-	15.71	1.81	3.32	21000	-

\*\* Please use this order pattern: Order-No. + „stroke in mm“ (5 digits)  
Example: SLIDELINE guide without brake D25 mm, stroke 1000 mm: 20342-01000

**For linear drives** see page 9-13, **for ATEX-version** see page 35, 36  
**For mountings** see page 107-115

The right to introduce technical modifications is reserved

## Dimensions

### Series OSP-P

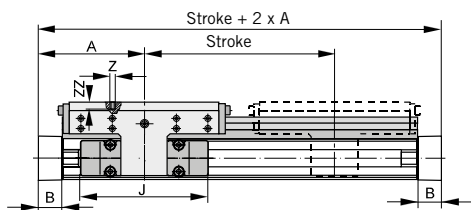

Air connection for brake (Option)

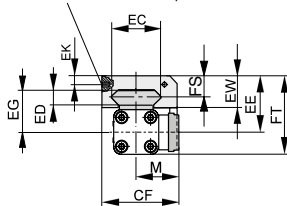

For further mounting elements and options see accessories.

For further information and technical data see data sheets for linear drives OSP-P (from page 15)

Air connection for brake (Option)

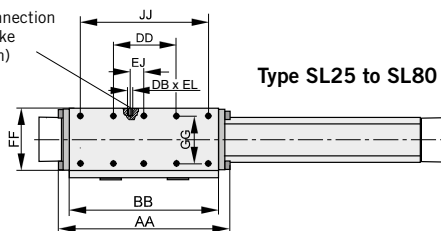

Type SL25 to SL80

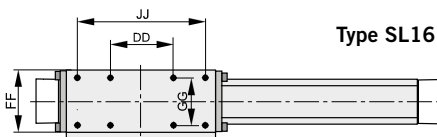

Type SL16

### Dimension Table [mm]

Series	A	B	J	M	Z	AA	BB	DB	DD	CF	EC	ED	EE	EG	EJ	EK	EL	EW	FF	FT	FS	GG	JJ	ZZ
SL16	65	14	69	31	M4	106	88	-	30	55	36	8	40	30	-	-	-	22	48	55	14	36	70	8
SL25	100	22	117	40.5	M6	162	142	M5	60	72.5	47	12	53	39	22	6	6	30	64	73.5	20	50	120	12
SL32	125	25.5	152	49	M6	205	185	M5	80	91	67	14	62	48	32	6	6	33	84	88	21	64	160	12
SL40	150	28	152	55	M6	240	220	M5	100	102	77	14	64	50	58	6	6	34	94	98.5	21.5	78	200	12
SL50	175	33	200	62	M6	284	264	M5	120	117	94	14	75	56	81	6	6	39	110	118.5	26	90	240	16
SL63	215	38	256	79	M8	312	292	-	130	152	116	18	86	66	-	-	-	46	152	139	29	120	260	14
SL80	260	47	348	96	M8	312	292	-	130	169	116	18	99	79	-	-	-	46	152	165	29	120	260	14

## Mid-Section Support

(for versions see page 109)

Mid-section supports are required from a certain stroke length to prevent excessive deflection and vibration of the linear drive. The diagrams show the maximum permissible unsupported length in relation to loading.

A distinction must be drawn between loading 1 and loading 2. Deflection of 0.5 mm max. between supports is permissible.

### Note:

For speeds  $v > 0.5$  m/s the distance between supports should not exceed 1 m.

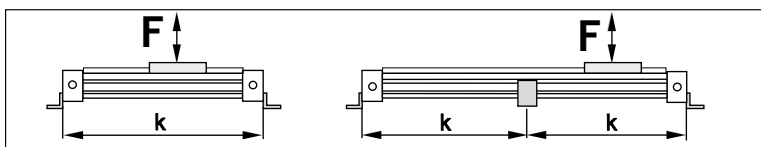
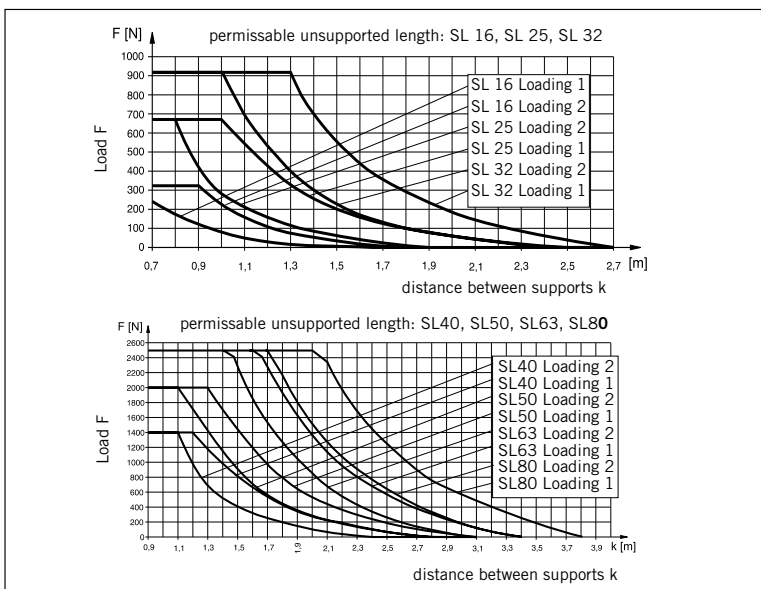
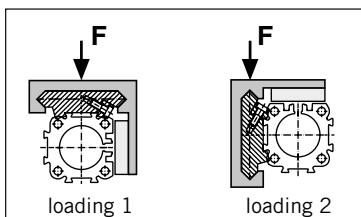

Order Instructions – SLIDELINE																
1-4	5+6	7	8	9	10	11	12-16	17	18	19	20	21	22	23	24	25
OSPP	25	0	0	0	0	0	01100	0	0	0	2	0	0	0	0	0

Piston-Ø
16
25
32
40
50
63
80

Stroke
Input in mm (5 digits)

Piston Mounting
0 without

Measuring system
0 without
X SFI 0.1 mm
Y SFI 1 mm

Screws
0 standard
1 stainless

Cushioning
0 standard
1 max. length <sup>3)</sup>

Version / Piston
0 standard
1 Tandem

Lubrication
0 standard
1 slow speed <sup>2)</sup>

End cap position
0 L + R 0° = in front
1 L + R 90° = underneath
2 L + R 180° = at the back
3 L + R 270° = same side as outerband
4 L 90° = underneath; R 0° = in front
5 L 180° = at the back; R 0° = in front
6 L 270° = same side as outerband; R 0° = in front
7 L 0° = in front; R 90° = underneath
8 L 180° = at the back; R 90° = underneath
9 L 270° = same side as outerband; R 90° = underneath
A L 0° = in front; R 180° = at the back
B L 90° = underneath; R 180° = at the back
C L 270° = same side as outerband; R 180° = at the back
D L 0° = in front; R 270° = same side as outerband
E L 90° = underneath; R 270° = same side as outerband
F L 180° = at the back; R 270° = same side as outerband

Guides/ Brakes
2 Slideline SL Ø 16-80
3 Slideline with Activebrake SL-AB Ø 25-50
4 Slideline with Multibrake SL-MB Ø 25-80

Cover / Cable Channel
0 standard
1 cable channel
2 cable channel two-sided
X without Cover rail

Air Connection
0 standard
1 on the end face
2 both at one end (not turnable)
3 left standard right end face
4 right standard left end face
A 3/2 way valve VOE 24 V = Ø 25,32,40,50
B 3/2 way valve VOE 230 V~/110 V = Ø 25,32,40,50
C 3/2 way valve VOE 48 V = Ø 25,32,40,50
E 3/2 way valve VOE 110 V = Ø 25,32,40,50

Seals
0 standard (NBR)
1 Viton <sup>® 1)</sup>

add. Guide Carriage
0 without
2 Guide Carriage Slideline SL Ø 16-80
3 Guide Carriage Slideline Activebrake SL-AB Ø 25-50
4 Guide Carriage Slideline Multibrake SL-MB Ø 25-80
M Guide Carriage Slideline Multibrake SL-MB without brakefunction Ø 25-80

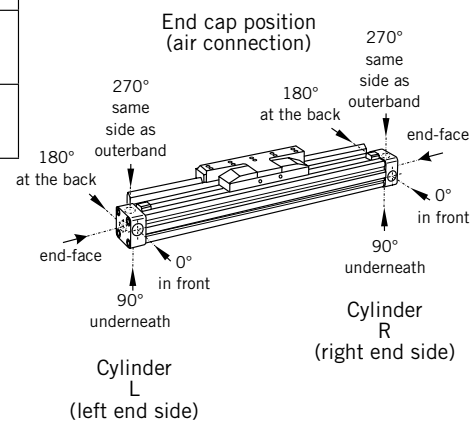

The right to introduce technical modifications is reserved

<sup>1)</sup> Viton with VOE not possible.  
<sup>2)</sup> "Slow speed lubrication" in combination with „Viton®“ seals on demand.  
<sup>3)</sup> „Lubrication slow speed“ in combination with „max. cushioning length“ not possible.



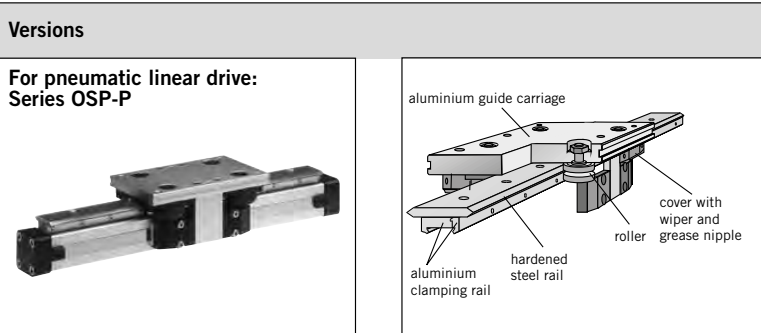

# Roller Guide POWERSLIDE



**Series PS 16 to 50  
for Linear-drive**  
• Series OSP-P

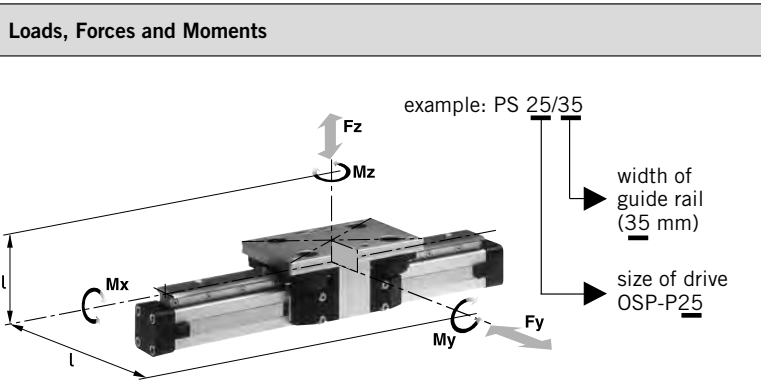

**Technical Data**

The Table shows the maximum permissible values for smooth operation, which should not be exceeded even under dynamic conditions. For further information and technical data see data sheets for linear drives OSP-P (from page 15).

**\* Please note:**  
In the cushioning diagram, add the mass of the guide carriage to the mass to be cushioned.

**Features:**

- Anodised aluminium guide carriage with vee rollers having 2 rows of ball bearings
- Hardened steel guide rail
- Several guide sizes can be used on the same drive
- Corrosion resistance version available on request
- Max. speed  $v = 4$  m/s,
- Tough roller cover with wiper and grease nipple
- Any length of stroke up to 3500 mm, (longer strokes on request)

Series	For linear drive	Max. Moment [Nm]			Max. loads [N] Fy, Fz	Mass of linear drive with guide [kg]		Mass * guide carriage [kg]	Order-No ** POWERSLIDE Guide without cylinder <sup>1)</sup>
		Mx	My	Mz		with 0 mm stroke	increase per 100 mm stroke		
PS 16/25	OSP-P16	14	45	45	1400	0.93	0.24	0.7	20285
PS 25/25	OSP-P25	14	63	63	1400	1.5	0.4	0.7	20015
PS 25/35	OSP-P25	20	70	70	1400	1.7	0.4	0.8	20016
PS 25/44	OSP-P25	65	175	175	3000	2.6	0.5	1.5	20017
PS 32/35	OSP-P32	20	70	70	1400	2.6	0.6	0.8	20286
PS 32/44	OSP-P32	65	175	175	3000	3.4	0.7	1.5	20287
PS 40/44	OSP-P40	65	175	175	3000	4.6	1.1	1.5	20033
PS 40/60	OSP-P40	90	250	250	3000	6	1.3	2.2	20034
PS 50/60	OSP-P50	90	250	250	3000	7.6	1.4	2.3	20288
PS 50/76	OSP-P50	140	350	350	4000	11.5	1.8	4.9	20289

<sup>1)</sup> corrosion resistance version on request (max.loads and moments are 25% lower)

\*\* Please use this order pattern: Order-No. + „stroke in mm“ (5 digits)  
Example: PS25/25 Guide D25 mm, stroke 1000 mm: 20015-01000

For linear drives see page 9-13  
For mountings see page 107-115

The right to introduce technical modifications is reserved

## Dimensions

### Series OSP-P

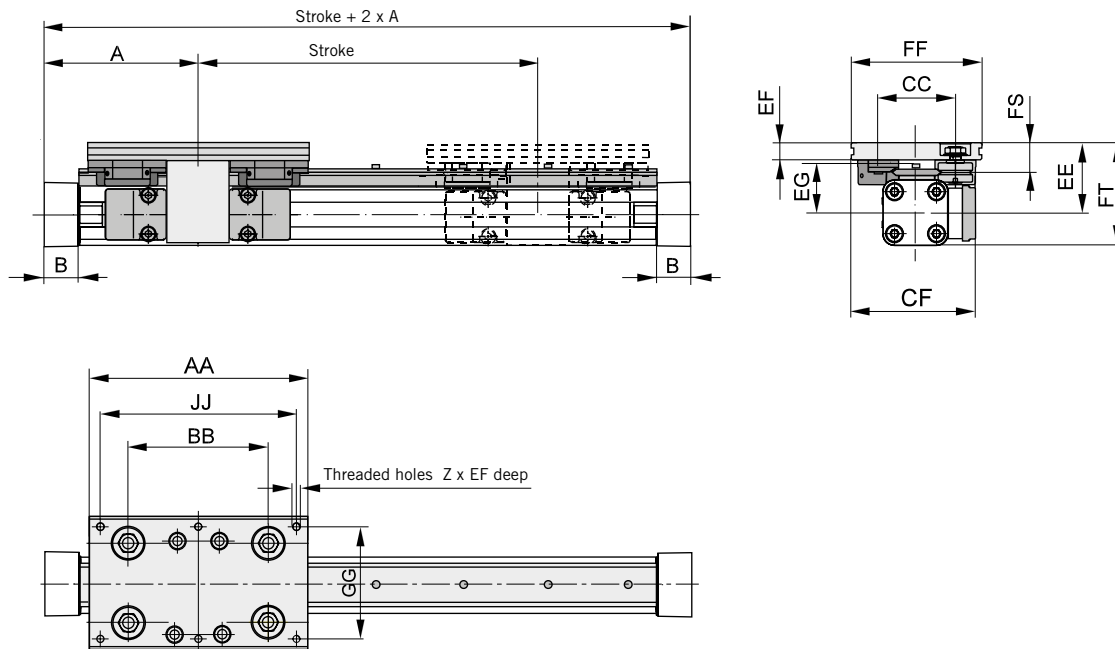

### Dimension Table [mm]

Series	A	B	Z	AA	BB	CC	CF	EE	EF	EG	FF	FS	FT	GG	JJ
PS 16/25	65	14	4xM6	120	65	47	80	49	12	35	80	21	64	64	100
PS 25/25	100	22	6xM6	145	90	47	79.5	53	11	39	80	20	73.5	64	125
PS 25/35	100	22	6xM6	156	100	57	89.5	52.5	12.5	37.5	95	21.5	73	80	140
PS 25/44	100	22	6xM8	190	118	73	100	58	15	39	116	26	78.5	96	164
PS 32/35	125	25.5	6xM6	156	100	57	95.5	58.5	12.5	43.5	95	21.5	84.5	80	140
PS 32/44	125	25.5	6xM8	190	118	73	107	64	15	45	116	26	90	96	164
PS 40/44	150	28	6xM8	190	118	73	112.5	75	15	56	116	26	109.5	96	164
PS 40/60	150	28	6xM8	240	167	89	122.5	74	17	54	135	28.5	108.5	115	216
PS 50/60	175	33	6xM8	240	167	89	130.5	81	17	61	135	28.5	123.5	115	216
PS 50/76	175	33	6xM10	280	178	119	155.5	93	20	64	185	39	135.5	160	250

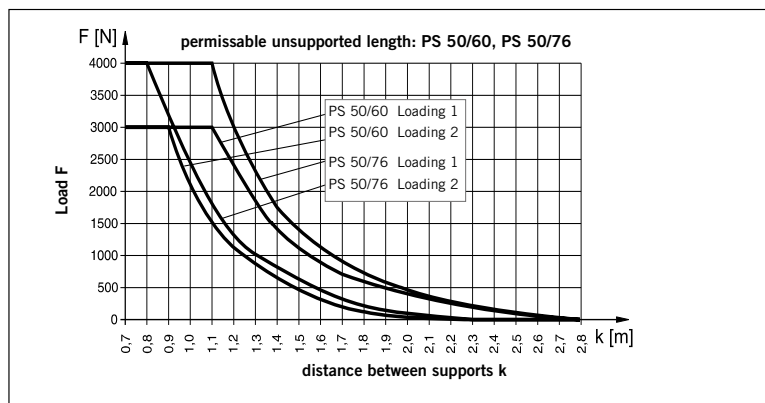
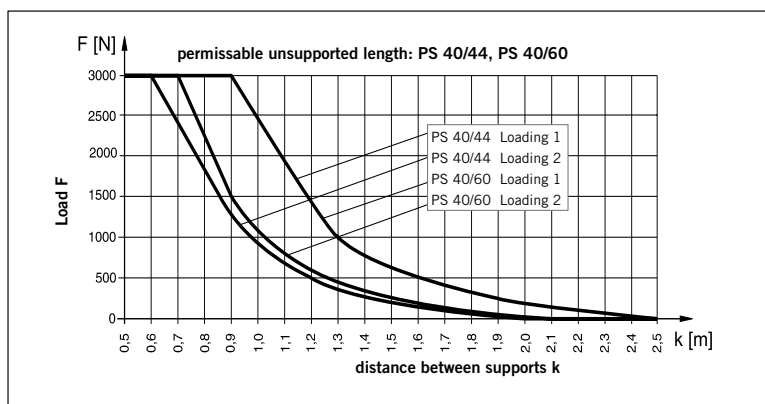
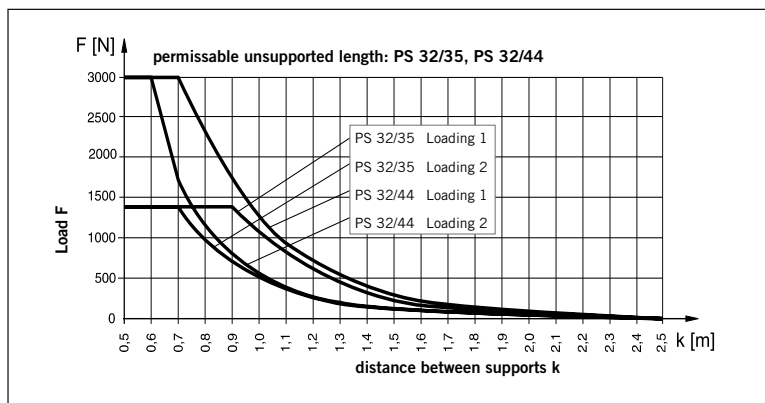
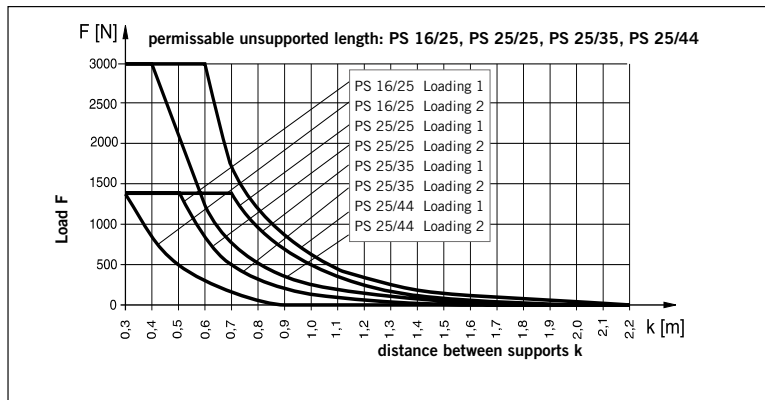

## Mid-Section Support

(for versions, see accessories)

Mid section supports are required from a certain stroke length to prevent excessive deflection and vibration of the linear drive. The diagrams show the maximum permissible unsupported length in relation to loading. A distinction must be drawn between loading 1 and loading 2. Deflection of 0.5 mm max. between supports is permissible.

### Note

For speeds  $v > 0.5$  m/s the distance between supports should not exceed 1m.

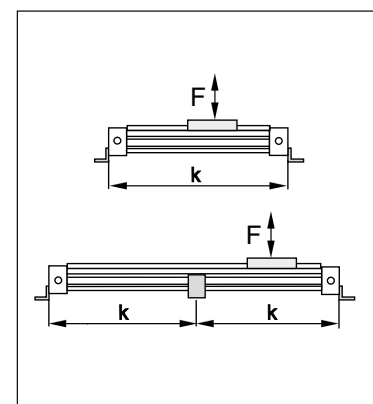
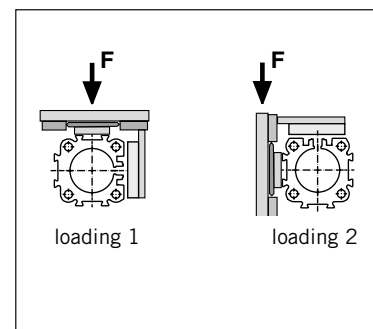

For further mounting elements and options see from page 101.

The right to introduce technical modifications is reserved

## Service life

Calculation of service life is achieved in two stages:

- Determination of load factor  $L_F$  from the loads to be carried
- Calculation of service life in km

### 1. Calculation of load factor $L_F$

$$L_F = \frac{M_x}{M_{x_{max}}} + \frac{M_y}{M_{y_{max}}} + \frac{M_z}{M_{z_{max}}} + \frac{F_y}{F_{y_{max}}} + \frac{F_z}{F_{z_{max}}}$$

with combined loads,  $L_F$  should not exceed the value 1.

## Lubrication

For maximum system life, lubrication of the rollers must be maintained at all times.

Only high quality Lithium based greases should be used.

Lubrication intervals are dependant on environmental conditions (temperature, running speed, grease quality etc.) therefore the installation should be regularly inspected.

### 2. Service life calculation

- |  |   |
|--|---|
| • For PS 16/25, PS 25/25, PS 25/35, and PS 32/35           | Service life [km] = $\frac{106}{(L_F + 0,02)^3}$  |
| • For PS 25/44, PS 32/44, PS 40/44, PS 40/60 and PS 50/60: | Service life [km] = $\frac{314}{(L_F + 0,015)^3}$ |
| • For PS 50/76:  | Service life [km] = $\frac{680}{(L_F + 0,015)^3}$ |

Order Instructions – POWERSLIDE																
1-4	5+6	7	8	9	10	11	12-16	17	18	19	20	21	22	23	24	25
OSPP	25	0	0	0	0	0	01100	0	0	0	E	0	0	0	0	0

Piston-Ø
16
25
32
40
50

Stroke
Input in mm (5 digits)

Piston Mounting
0 without

Measuring system
0 without
X SFI 0.1 mm
Y SFI 1 mm

Screws
0 standard
1 stainless

Cushioning
0 standard
1 max. length <sup>3)</sup>

Version / Piston
0 standard
1 Tandem

Lubrication
0 standard
1 Slow speed <sup>2)3)</sup>

End cap position
0 L + R 0° = in front
1 L + R 90° = underneath
2 L + R 180° = at the back
3 L + R 270° = same side as outerband
4 L 90° = underneath; R 0° = in front
5 L 180° = at the back; R 0° = in front
6 L 270° = same side as outerband; R 0° = in front
7 L 0° = in front; R 90° = underneath
8 L 180° = at the back; R 90° = underneath
9 L 270° = same side as outerband; R 90° = underneath
A L 0° = in front; R 180° = at the back
B L 90° = underneath; R 180° = at the back
C L 270° = same side as outerband; R 180° = at the back
D L 0° = in front; R 270° = same side as outerband
E L 90° = underneath; R 270° = same side as outerband
F L 180° = at the back; R 270° = same side as outerband

Guides/ Brakes
E PSXX/25 Powerslide Ø 16, 25
F PSXX/35 Powerslide Ø 25, 32
G PSXX/44 Powerslide Ø 25, 32, 40
H PSXX/60 Powerslide Ø 40, 50
I PSXX/76 Powerslide Ø 50

Cover / Cable Channel
0 standard
1 cable channel
2 cable channel two-sided
X without Cover rail

Air Connection
0 standard
1 on the end face
2 both at one end (not turnable)
3 left standard right end face
4 right standard left end face
A 3/2 way valve VOE 24 V = Ø 25, 32, 40, 50
B 3/2 way valve VOE 230 V~/110 V = Ø 25, 32, 40, 50
C 3/2 way valve VOE 48 V = Ø 25, 32, 40, 50
E 3/2 way valve VOE 110 V~/ Ø 25, 32, 40, 50

Seals
0 standard (NBR)
1 Viton <sup>®1)</sup>

add. Guide Carriage
0 without
E Guide Carriage Powerslide PSXX/25 Ø 16, 25
F Guide Carriage Powerslide PSXX/35 Ø 25, 32
G Guide Carriage Powerslide PSXX/44 Ø 25, 32, 40
H Guide Carriage Powerslide PSXX/60 Ø 40, 50
I Guide Carriage Powerslide PSXX/76 Ø 50

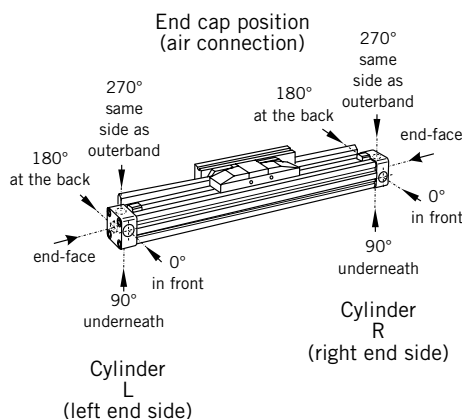

<sup>1)</sup> Viton with VOE not possible.

<sup>2)</sup> "Slow speed lubrication" in combination with „Viton®“ seals on demand.

<sup>3)</sup> „Lubrication slow speed“ in combination with „max. cushioning length“ not possible.



### Versions

for pneumatic linear drive:  
Series OSP-P

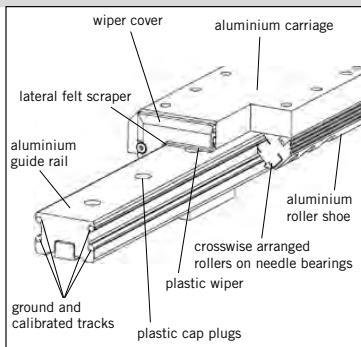

# Aluminium Roller Guide PROLINE

**OSP**  
ORIGA  
SYSTEM  
PLUS

Series PL 16 to 50  
for Linear-drive  
• Series OSP-P

### Technical Data

The table shows the maximal permissible loads. If multiple moments and forces act upon the cylinder simultaneously, the following equation applies:

$$\frac{M_x}{M_{x_{max}}} + \frac{M_y}{M_{y_{max}}} + \frac{M_z}{M_{z_{max}}} + \frac{F_y}{F_{y_{max}}} + \frac{F_z}{F_{z_{max}}} \leq 1$$

The sum of the loads should not exceed >1.  
With a load factor of less than 1, service life is 8000 km

The table shows the maximum permissible values for light, shock-free operation, which must not be exceeded even under dynamic conditions.

### Option – Integrated Brake

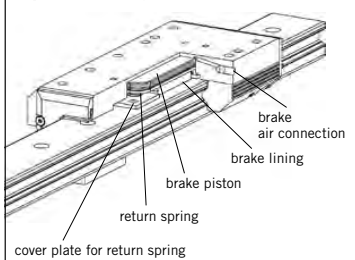

### Features:

- High precision
- High velocities (10 m/s)
- Smooth operation - low noise
- Integrated wiper system
- Long life lubrication
- Compact dimensions - compatible to Slideline plain bearing guide
- Any length of stroke up to 3750 mm

### Integrated Brake (optional) for Series OSP-P25 to OSP-P50:

- Actuated by pressurisation
- Release by depressurisation and spring actuation

### Loads, Forces and Moments

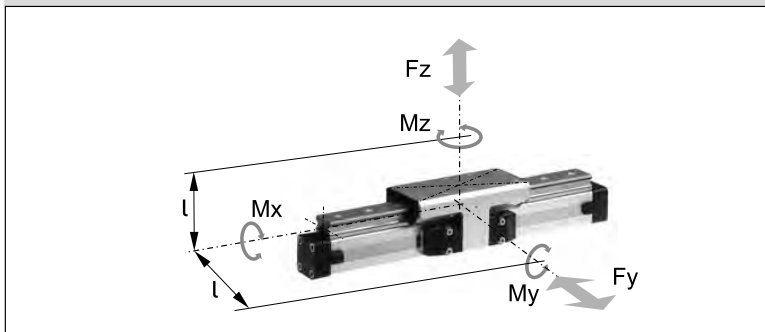

### \* Please note:

The mass of the carriage has to be added to the total moving mass when using the cushioning diagram.

Series	For linear drive	Max. Moment [Nm]			Max. loads [N] Fy, Fz	Maximum braking force at 6 bar [N] <sup>1)</sup>	Mass of linear drive with guide [kg]		Mass * guide carriage [kg]	Order-No ** PROLINE Guide without cylinder	
		Mx	My	Mz			with 0 mm stroke	increase per 100 mm stroke		without Brake	with Brake
PL 16	OSP-P16	8	12	12	542	-	0.55	0.19	0.24	20855	-
PL 25	OSP-P25	16	39	39	857	on request	1.65	0.40	0.75	20856	20860
PL 32	OSP-P32	29	73	73	1171	on request	3.24	0.62	1.18	20857	20861
PL 40	OSP-P40	57	158	158	2074	on request	4.35	0.70	1.70	20858	20862
PL 50	OSP-P50	111	249	249	3111	on request	7.03	0.95	2.50	20859	20863

<sup>1)</sup> Only with integrated brake: Braking surface on dry, oil-free surface - Values are decreased at oiled braking surface

\*\* Please use this order pattern: Order-No. + „stroke in mm“ (5 digits)

Example: PROLINE guide without brake D16 mm, stroke 1000 mm: 20855-01000

For linear drives see page 9-13  
For mountings see page 107-115

The right to introduce technical modifications is reserved

Dimension Table [mm] Series OSP-P PL16, PL25, PL32, PL40, PL50

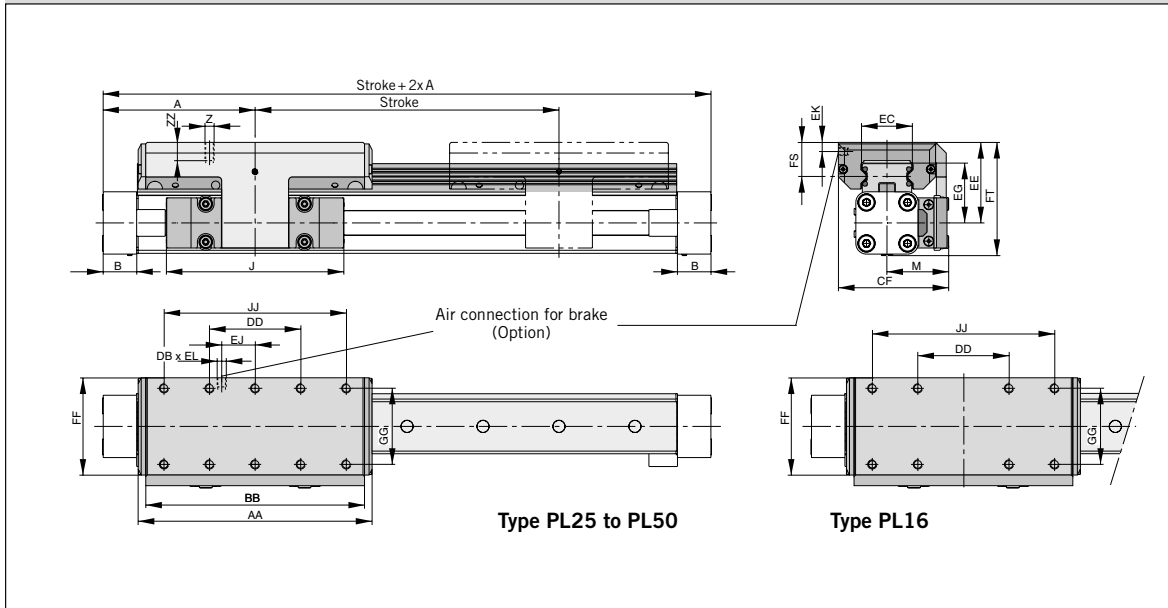

Dimension Table [mm] Series OSP-P PL16, PL25, PL32, PL40, PL50

Series	A	B	J	M	Z	AA	BB	DB	DD	CF	EC	EE	EG	EJ	EK	EL	FF	FS	FT	GG	JJ	ZZ
PL16	65	14	69	31	M4	98	88	-	30	55	23	40	30	-	-	-	48	17	55	36	70	8
PL25	100	22	117	40.5	M6	154	144	M5	60	72.5	32.5	53	39	22	6	6	64	23	73.5	50	120	12
PL32	125	25.5	152	49	M6	197	187	M5	80	91	42	62	48	32	6	6	84	25	88	64	160	12
PL40	150	28	152	55	M6	232	222	M5	100	102	47	64	50.5	58	6	6	94	23.5	98.5	78	200	12
PL50	175	33	200	62	M6	276	266	M5	120	117	63	75	57	81	6	6	110	29	118.5	90	240	16

## Mid-Section Support

(For versions, see page 107-115)  
 Mid-section supports are required from a certain stroke length to prevent excessive deflection and vibration of the linear drive. The diagrams show the maximum permissible unsupported length in relation to loading. A distinction must be drawn between loading 1 and loading 2. Deflection of 0.5 mm max. between supports is permissible.

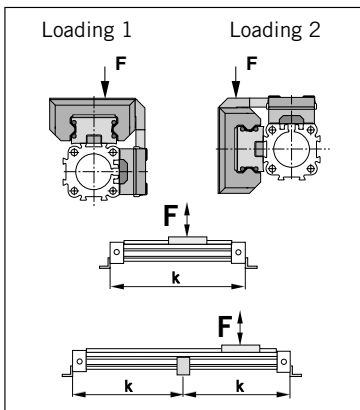

### Note:

For speeds  $v > 0.5$  m/s the distance between supports should not exceed 1 m.

Permissible Unsupported Length PL16, PL25, PL32, PL40 and PL50

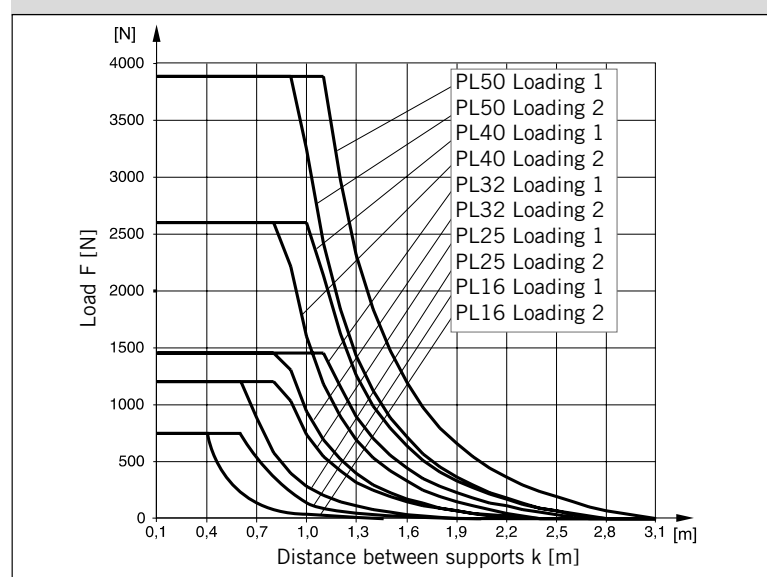

Order Instructions – PROLINE																
1-4	5+6	7	8	9	10	11	12-16	17	18	19	20	21	22	23	24	25
OSPP	25	0	0	0	0	0	01100	0	0	0	6	0	0	0	0	0

Piston-Ø
16
25
32
40
50

Stroke
Input in mm (5 digits)

Piston Mounting
0 without

Measuring system
0 without
X SFI 0.1 mm
Y SFI 1 mm

Screws
0 standard

Cushioning
0 standard
1 max. length <sup>3)</sup>

Version / Piston
0 standard
1 Tandem

Lubrication
0 standard
1 Slow speed <sup>2)3)</sup>

End cap position
0 L + R 0° = in front
1 L + R 90° = underneath
2 L + R 180° = at the back
3 L + R 270° = same side as outerband

Guides/ Brakes
6 Proline PL Ø 16-50
7 Proline with Activebrake PL-AB Ø 25-50
8 Proline with Multibrake PL-MB Ø 25-50

Cover / Cable Channel
0 standard
1 cable channel
2 cable channel two-sided
X without Cover rail

Air Connection
0 standard
1 on the end face
2 both at one end (not turnable)
3 left standard right end face
4 right standard left end face
A 3/2 way valve VOE 24 V = Ø 25, 32, 40, 50
B 3/2 way valve VOE 230 V~/110 V = Ø 25, 32, 40, 50
C 3/2 way valve VOE 48 V = Ø 25, 32, 40, 50
E 3/2 way valve VOE 110 V~ Ø 25, 32, 40, 50

Seals
0 standard (NBR)
1 Viton <sup>® 1)</sup>

4 L 90° = underneath; R 0° = in front
5 L 180° = at the back; R 0° = in front
6 L 270° = same side as outerband; R 0° = in front
7 L 0° = in front; R 90° = underneath
8 L 180° = at the back; R 90° = underneath
9 L 270° = same side as outerband; R 90° = underneath
A L 0° = in front; R 180° = at the back
B L 90° = underneath; R 180° = at the back
C L 270° = same side as outerband; R 180° = at the back
D L 0° = in front; R 270° = same side as outerband
E L 90° = underneath; R 270° = same side as outerband
F L 180° = at the back; R 270° = same side as outerband

add. Guide Carriage
0 without
6 Guide Carriage Proline PL Ø 16-50
7 Guide Carriage Proline Activebrake PL-AB Ø 25-50
8 Guide Carriage Proline Multibrake PL-MB Ø 25-50
N Guide Carriage Proline Multibrake PL-MB without brake function Ø 25-50

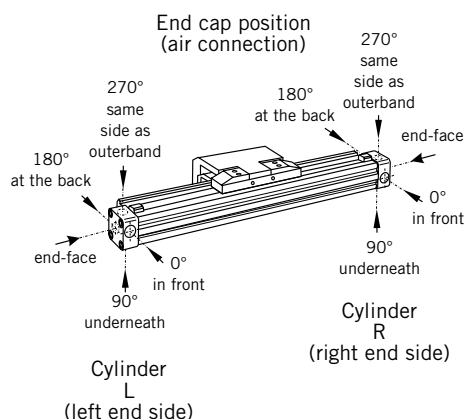

1) Viton with VOE not possible.  
 2) "Slow speed lubrication" in combination with „Viton®“ seals on demand.  
 3) „Lubrication slow speed“ in combination with „max. cushioning length“ not possible.

The right to introduce technical modifications is reserved



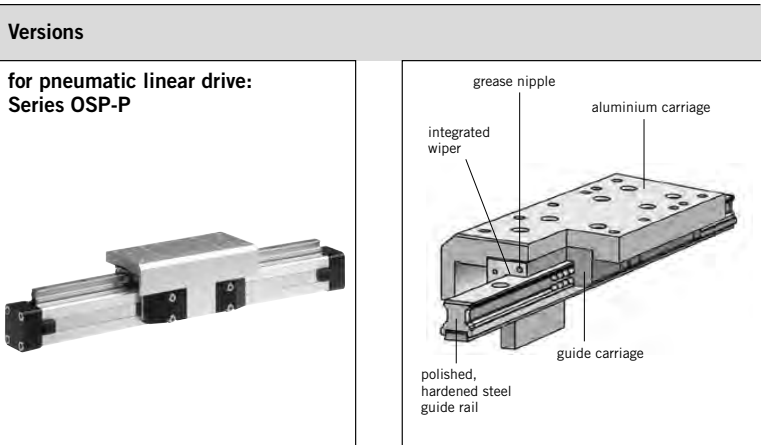

# Recirculating Ball Bearing Guide STARLINE



**Series STL 16 to 50  
for Linear Drive Series OSP-P**

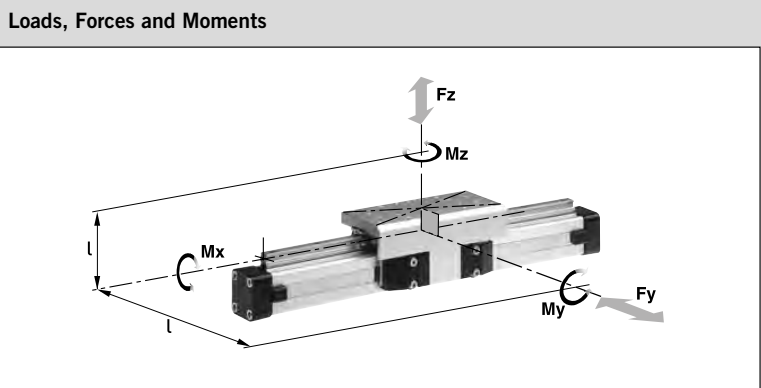

**Features:**

- Polished and hardened steel guide rail
- For very high loads in all directions
- High precision
- Integrated wiper system
- Integrated grease nipples
- Any length of stroke up to 3700 mm
- Anodized aluminium guide carriage – dimensions compatible with OSP guides SLIDELINE and PROLINE
- Installation height (STL16 - 32) compatible with OSP guides SLIDELINE and PROLINE
- Maximum speed  
STL16: v = 3 m/s  
STL25 to 50: v = 5 m/s

**Technical Data**

The table shows the maximum permissible loads. If multiple moments and forces act upon the cylinder simultaneously, the following equation applies:

$$\frac{M_x}{M_{x_{max}}} + \frac{M_y}{M_{y_{max}}} + \frac{M_z}{M_{z_{max}}} + \frac{F_y}{F_{y_{max}}} + \frac{F_z}{F_{z_{max}}} \leq 1$$

The sum of the loads should not exceed >1

The table shows the maximum permissible values for light, shock-free operation, which must not be exceeded even under dynamic conditions.

**\* Please note:**

The mass of the carriage has to be added to the total moving mass when using the cushioning diagram.

Series	For linear drive	Max. Moment [Nm]			Max. loads [N]		Mass of linear drive with guide [kg]		Mass * guide carriage [kg]	Order-No ** STARLINE Guide without cylinder
		Mx	My	Mz	Fy	Fz	with 0 mm stroke	increase per 100 mm stroke		
<b>STL 16</b>	OSP-P16	15	30	30	1000	1000	0.598	0.210	0.268	<b>21111</b>
<b>STL 25</b>	OSP-P25	50	110	110	3100	3100	1.733	0.369	0.835	<b>21112</b>
<b>STL 32</b>	OSP-P32	62	160	160	3100	3100	2.934	0.526	1.181	<b>21113</b>
<b>STL 40</b>	OSP-P40	150	400	400	4000	7500	4.452	0.701	1.901	<b>21114</b>
<b>STL 50</b>	OSP-P50	210	580	580	4000	7500	7.361	0.936	2.880	<b>21115</b>

\*\* Please use this order pattern: Order-No. + „stroke in mm“ (5 digits)  
Example: STARLINE guide D16 mm, stroke 1000 mm: 21111-01000

For linear drives see page 9-13  
For mountings see page 107-115

The right to introduce technical modifications is reserved

Dimensions Series OSP-P STL16 to STL 50

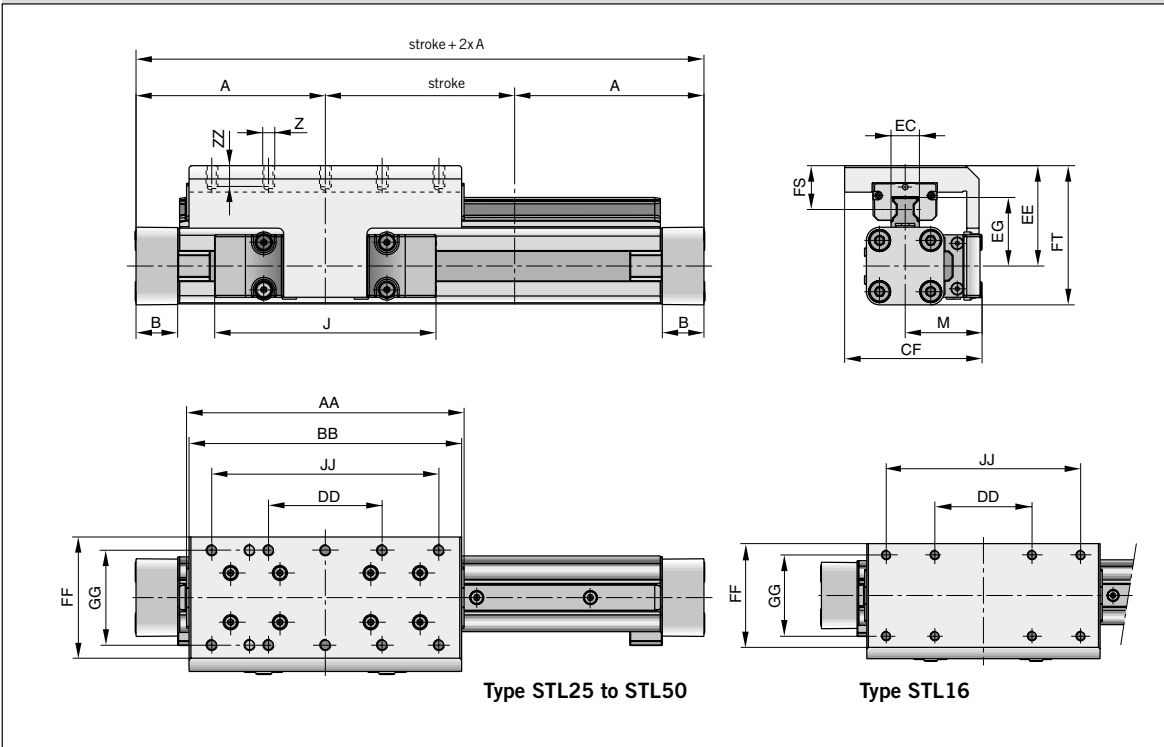

Dimension Table [mm] Series OSP-P STL16 to STL50

Series	A	B	J	M	Z	AA	BB	CF	DD	EC	EE	EG	FF	FS	FT	GG	JJ	ZZ
STL16	65	14	69	31	M4	93	90	55	30	15	40	24.6	48	18	55	36	70	8
STL25	100	22	117	40.5	M6	146.6	144	72.5	60	15	53	36.2	64	23.2	73.5	50	120	12
STL32	125	25.5	152	49	M6	186.6	184	91	80	15	62	42.2	84	26.2	88	64	160	12
STL40	150	28	152	55	M6	231	226	102	100	20	72	51.6	94	28.5	106.5	78	200	12
STL50	175	33	200	62	M6	270.9	266	117	120	23	85	62.3	110	32.5	128.5	90	240	16

### Permissible Unsupported Length STL16 to STL50

Loading 1 – Top carrier

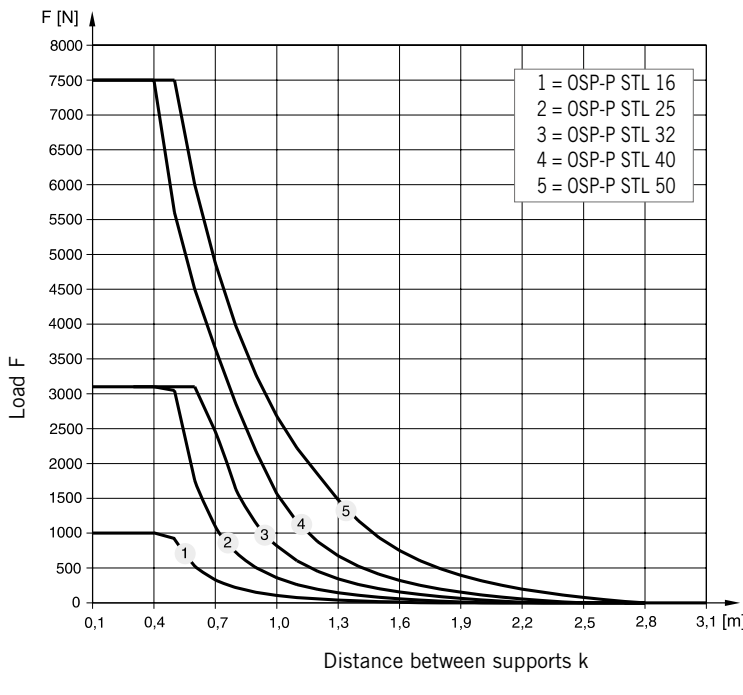

### Permissible Unsupported Length STL16 to STL50

Loading 2 – Side carrier

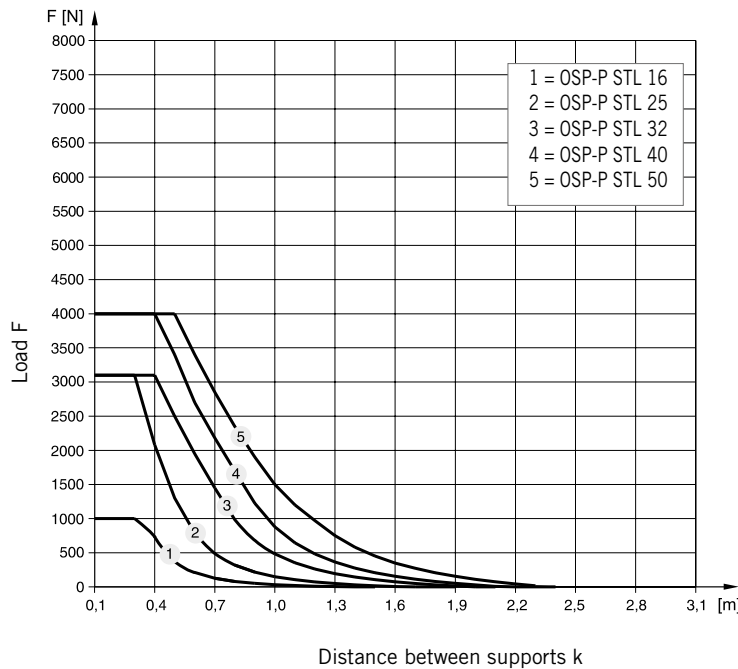

## Mid-Section Support

(For versions, see page 106-107)

Mid-section supports are required from a certain stroke length to prevent excessive deflection and vibration of the linear drive. The diagrams show the maximum permissible unsupported length in relation to loading. A distinction must be drawn between loading 1 and loading 2. Deflection of 0.5 mm max. between supports is permissible.

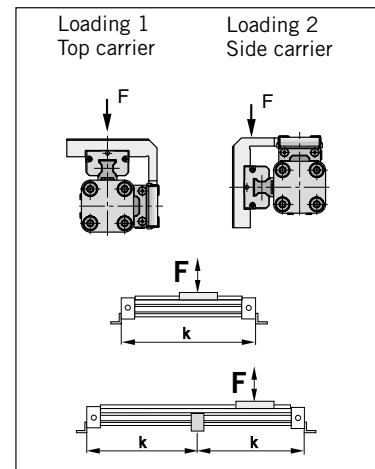

### Note:

For speeds  $v > 0.5$  m/s the distance between supports should not exceed 1 m.

## Variable Stop

The variable stop Type VS provides simple stroke limitation.

It can be retrofitted and positioned anywhere along the stroke length. For every cylinder diameter two types of shock absorber are available – see „Shock Absorber Selection“ below.

Mid-section supports and magnetic switches can still be fitted on the same side as the variable stop.

Depending on the application, two variable stops can be fitted if required.

### Variable Stop Type VS16 to VS50

Arrangement with two variable stops

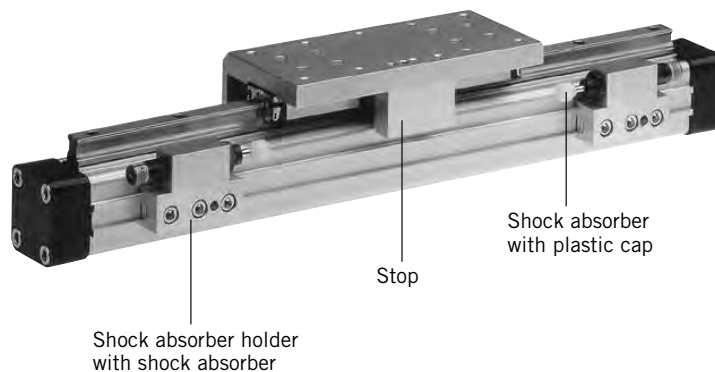

## Shock Absorber Selection

The shock absorber is selected in dependence on the mass and speed.

The mass of the carrier itself must be taken into account.

The values relate to an effective driving force of 78 N (6 bar)

### Shock Absorber Selection in Dependence on Mass and Speed for Series OSP-STL16

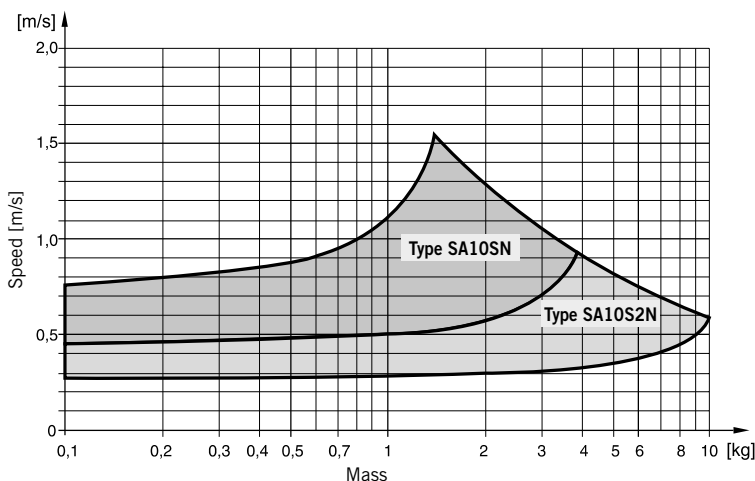

### Shock Absorber Selection in Dependence on Mass and Speed for Series OSP-STL25

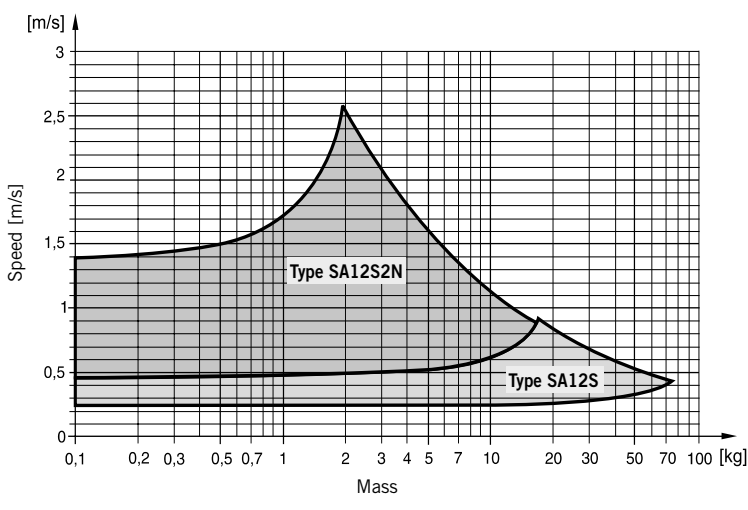

The values relate to an effective driving force of 250 N (6 bar)

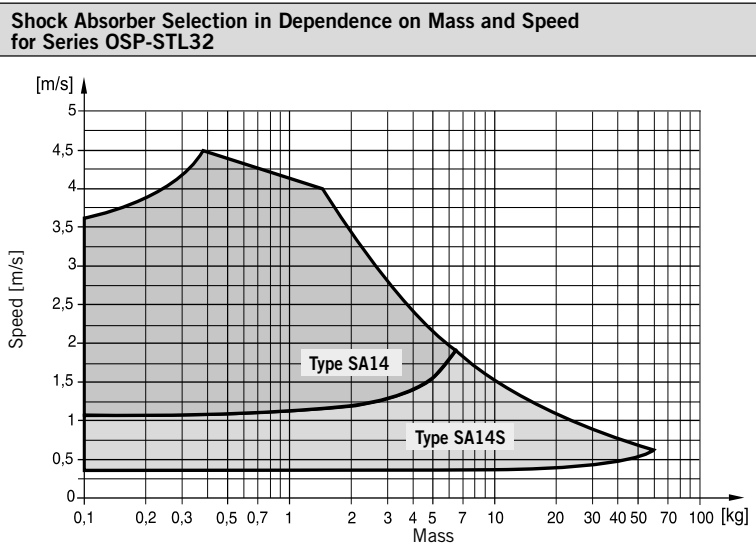

The values relate to an effective driving force of 420 N (6 bar)

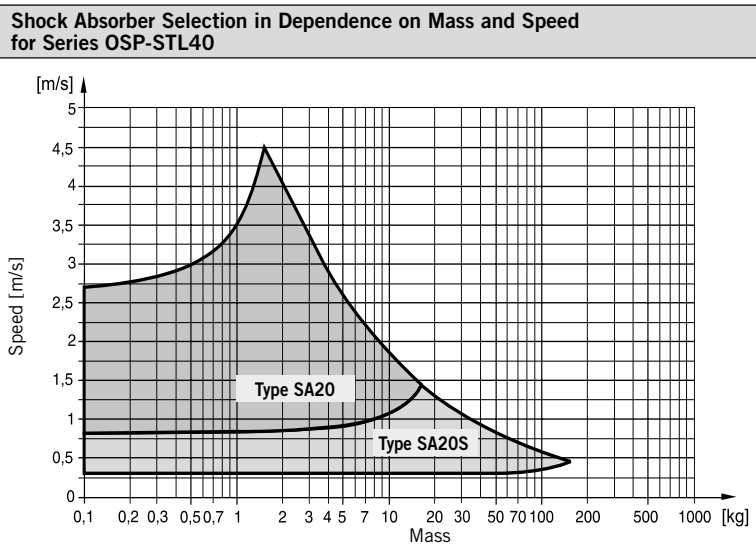

The values relate to an effective driving force of 640 N (6 bar)

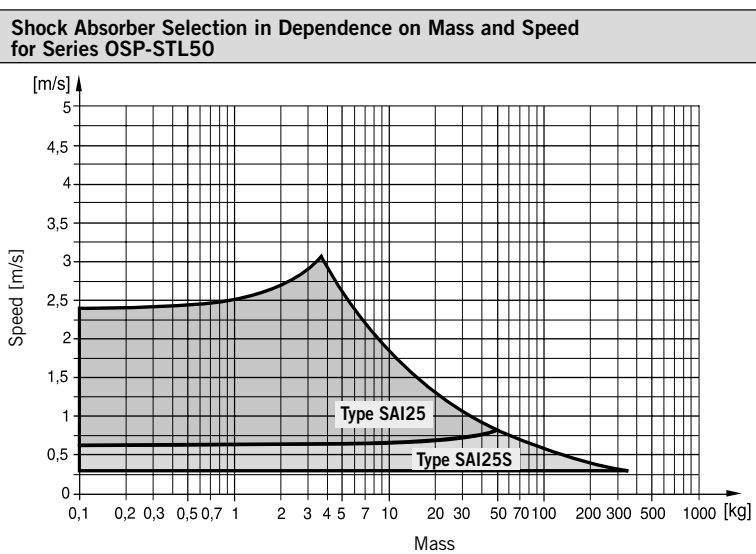

The values relate to an effective driving force of 1000 N (6 bar)

The right to introduce technical modifications is reserved

**Dimensions – Variable Stop Type VS16 to VS50**

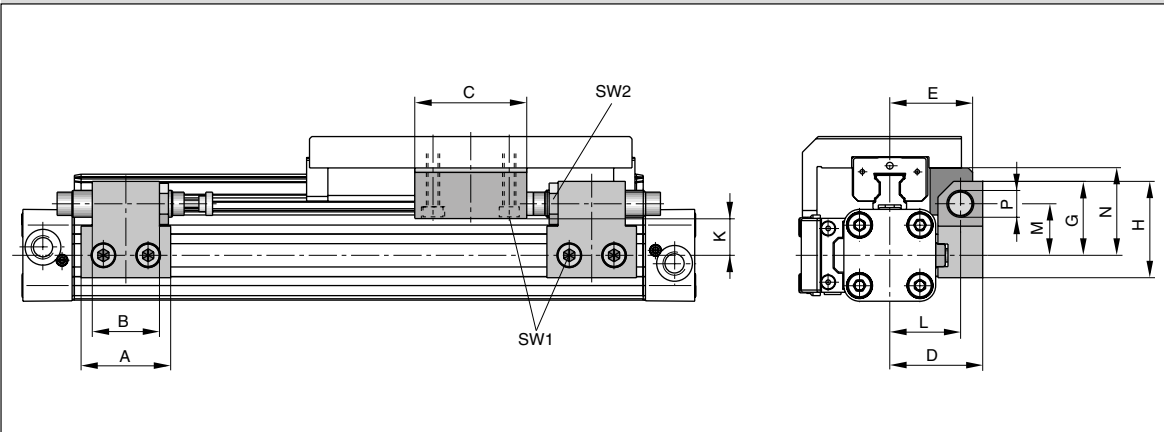

**Dimension Table [mm] – Variable Stop Type VS16 to VS50**

Series	Type	A	B	C	D	E	G	H	K	L	M	N	P	SW1	SW2
OSP-STL16	VS16	30	14	25	33	30	28	38	16.2	25.5	20.5	30	M10x1	4	12.5
OSP-STL25	VS25	40	30	50	41.5	37	33	43	18	31.5	23	39	M12x1	5	16
OSP-STL32	VS32	60	40	50	45.5	42	35	45	19	35.5	25	48	M14x1.5	5	17
OSP-STL40	VS40	84	52	60	64	59	48	63	25.6	50	34	58.6	M20x1.5	5	24
OSP-STL50	VS50	84	-	60	75	69	55	70	26.9	57	38	66.9	M25x1.5	5	30

**Order Information – Variable Stop Type VS16 to VS50**

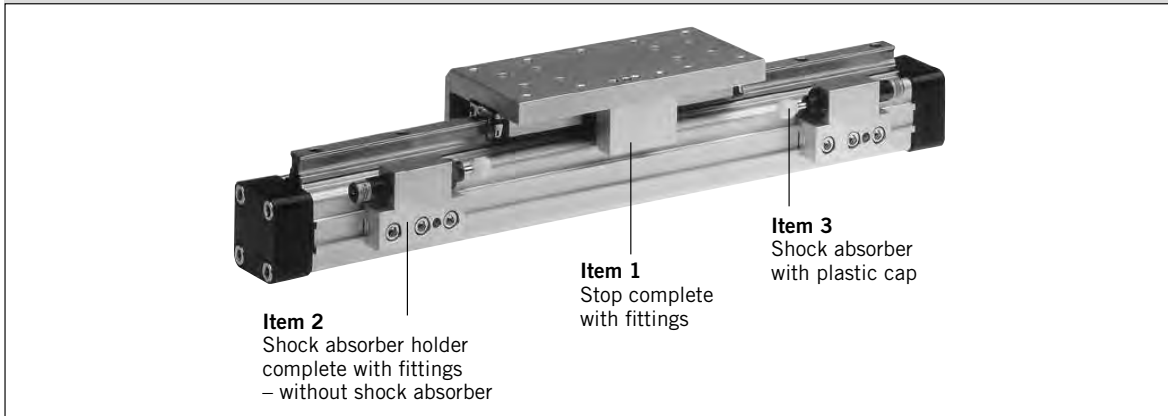

**Order Instructions – Variable Stop Type VS16 to VS50**

without cylinder and without guide

Item	Description	Size									
		VS16		VS25		VS32		VS40		VS50	
		Type	Order No.	Type	Order No.	Type	Order No.	Type	Order No.	Type	Order No.
1	Stop, complete	-	21196FIL	-	21197FIL	-	21198FIL	-	21199FIL	-	21200FIL
2	Shock absorber holder complete	-	21201FIL	-	21202FIL	-	21203FIL	-	21204FIL	-	21205FIL
3*	Shock absorber, soft	SA10SN	7718FIL	SA12S2N	7723FIL	SA14	7708FIL	SA20	7930FIL	SAI25	7712FIL
	Shock absorber, hard	SA10S2N	7721FIL	SA12S	7707FIL	SA14S	7709FIL	SA20S	7711FIL	SAI25S	7713FIL

\* Shock absorber with plastic cap

**Note:** Order instructions for VS in combination with the cylinder and guide see page 69, pos. 18

Order Instructions – STARLINE																
1-4	5+6	7	8	9	10	11	12-16	17	18	19	20	21	22	23	24	25
OSPP	25	0	0	0	0	0	01100	0	0	0	B	0	0	0	0	0

Piston-Ø
16
25
32
40
50

Stroke
Input in mm (5 digits)

Piston Mounting
0 without

Measuring system
0 without
X SFI 0.1 mm
Y SFI 1 mm

Screws
0 standard

Cushioning
0 standard
1 max. length <sup>3)</sup>
2 VS variable stop soft, left for Starline
3 VS variable stop hard, left for Starline
4 VS variable stop soft, right for Starline
5 VS variable stop hard, right for Starline
6 VS variable stop soft, both sides for Starline
7 VS variable stop hard, both sides for Starline

Version / Piston
0 standard
1 Tandem

Lubrication
0 standard
1 Slow speed <sup>2)3)</sup>

Cover / Cable Channel
0 standard
1 cable channel
2 cable channel two-sided
X without Cover rail

Air Connection
0 standard
1 on the end face
2 both at one end (not turnable)
3 left standard right end face
4 right standard left end face
A 3/2 way valve VOE 24 V = Ø 25, 32, 40, 50
B 3/2 way valve VOE 230 V~/110 V= Ø 25, 32, 40, 50
C 3/2 way valve VOE 48 V= Ø 25, 32, 40, 50
E 3/2 way valve VOE 110 V~ Ø 25, 32, 40, 50

Seals
0 standard (NBR)
1 Viton <sup>® 1)</sup>

End cap position
0 L + R 0° = in front
1 L + R 90° = underneath
2 L + R 180° = at the back
3 L + R 270° = same side as outerband
4 L 90° = underneath; R 0° = in front
5 L 180° = at the back; R 0° = in front
6 L 270° = same side as outerband; R 0° = in front
7 L 0° = in front; R 90° = underneath
8 L 180° = at the back; R 90° = underneath
9 L 270° = same side as outerband; R 90° = underneath
A L 0° = in front; R 180° = at the back
B L 90° = underneath; R 180° = at the back
C L 270° = same side as outerband; R 180° = at the back
D L 0° = in front; R 270° = same side as outerband
E L 90° = underneath; R 270° = same side as outerband
F L 180° = at the back; R 270° = same side as outerband

Guides/ Brakes
B Starline STL

add. Guide Carriage
0 without
B Guide Carriage Starline STL

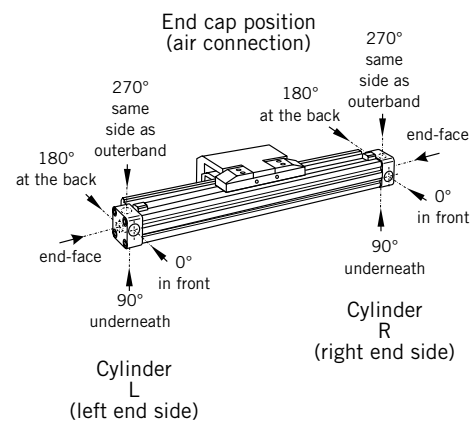

<sup>1)</sup> Viton with VOE not possible.

<sup>2)</sup> "Slow speed lubrication" in combination with „Viton<sup>®</sup>“ seals on demand.

<sup>3)</sup> „Lubrication slow speed“ in combination with „max. cushioning length“ not possible.

The right to introduce technical modifications is reserved



### Versions

for Pneumatic Linear Drive:  
Series OSP-P KF



# Recirculating Ball Bearing Guide KF



Series KF16 to KF50  
For Linear Drives  
Series OSP-P CLASSIC

### Loads, Forces and Moments

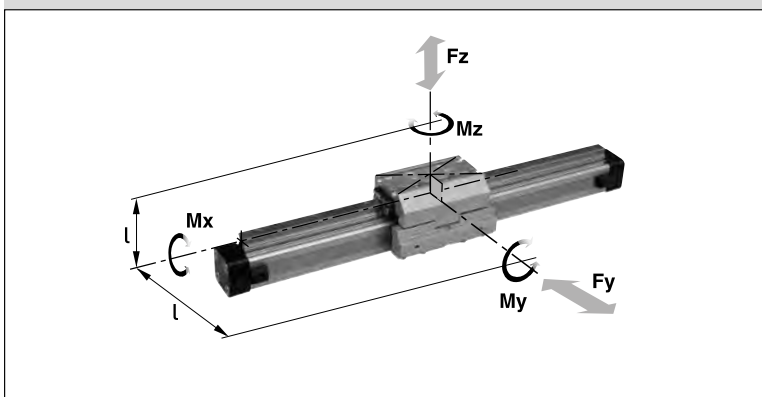

#### Features:

- Anodized aluminium guide carriage, the mounting dimensions correspond to FESTO Type: DGPL-KF
- Polished and hardened steel guide rail
- For high loads in all directions
- High precision
- Integrated wiper system
- Integrated grease nipples
- Any length of stroke up to 3700 mm
- Maximum speed  
KF16, KF40:  $v = 3$  m/s  
KF25, KF32, KF50:  $v = 5$  m/s

#### Technical Data

The table shows the maximum permissible loads. If multiple moments and forces act upon the cylinder simultaneously, the following equation applies:

$$\frac{M_x}{M_{x_{max}}} + \frac{M_y}{M_{y_{max}}} + \frac{M_z}{M_{z_{max}}} + \frac{F_y}{F_{y_{max}}} + \frac{F_z}{F_{z_{max}}} \leq 1$$

The sum of the loads should not exceed >1

The table shows the maximum permissible values for light, shock-free operation, which must not be exceeded even under dynamic conditions.

#### \* Please note:

the mass of the carriage has to be added to the total moving mass when using the cushioning diagram.

Series	For linear drive	Max. moment [Nm]			Max. loads [N]		Mass of linear drive with guide [kg]		Mass* guide carriage [kg]	Groove stone	Thread size	Order-No.	
		Mx	My	Mz	Fy	Fz	with 0 mm stroke	increase per 100 mm stroke				Groove Stone	Guide KF without cylinder**
KF16	OSP-P16	12	25	25	1000	1000	0.558	0.21	0.228	-	-	21101	
KF25	OSP-P25	35	90	90	3100	3100	1.522	0.369	0.607	M5	13508FIL	21102	
KF32	OSP-P32	44	133	133	3100	3100	2.673	0.526	0.896	M5	13508FIL	21103	
KF40	OSP-P40	119	346	346	4000	7100	4.167	0.701	1.531	M6	13509FIL	21104	
KF50	OSP-P50	170	480	480	4000	7500	7.328	0.936	2.760	M8	13510FIL	21105	

\*\* Please use this order pattern: Order-No. + „stroke in mm“ (5 digits)  
Example: KF guide D16 mm, stroke 1000 mm: 21101-01000

For linear drives see page 9-13  
For mountings see page 107-115

The right to introduce technical modifications is reserved

Dimensions Series OSP-P KF16 to KF50

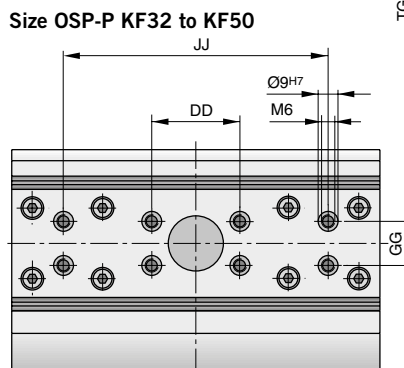
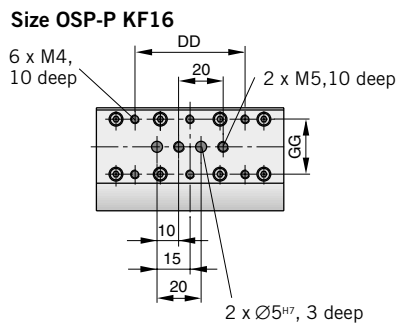
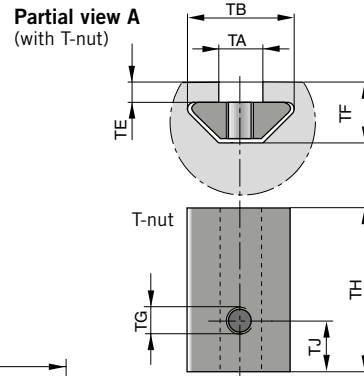
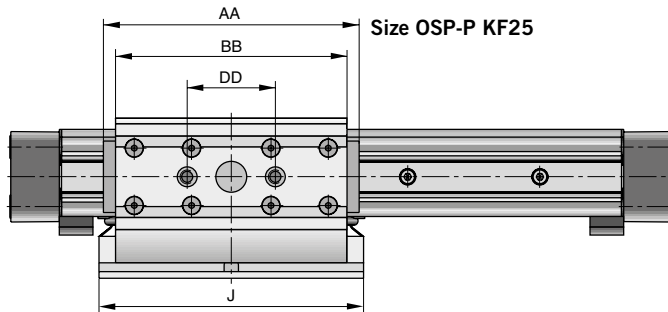
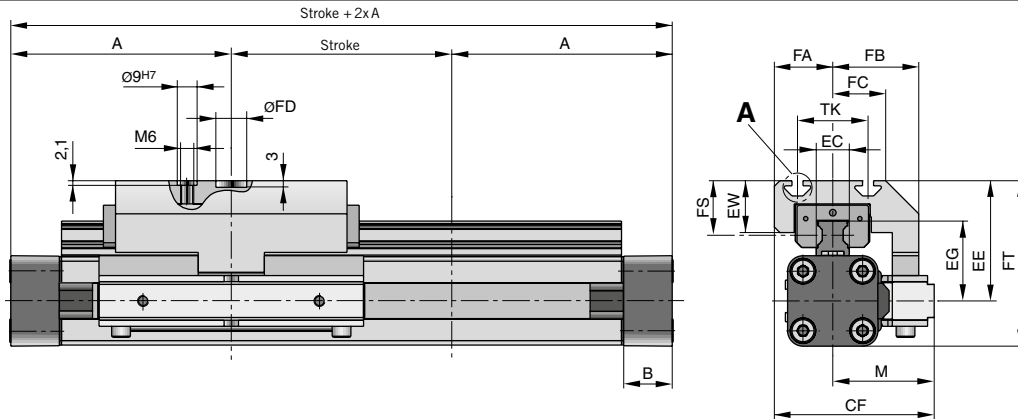

Dimension Table [mm] Series OSP-P KF16, KF25, KF32, KF40, KF50

Series	A	B	J	AA	BB	CF	DD	EC	EE	EG	EW	JJ	GG	M
KF16	65	14	76	93	85	48	50	15	41	24.6	10	-	25	30
KF25	100	22	120	120.2	105	72.5	40	15	54.5	36.2	23.5	-	-	46
KF32	125	25.5	160	146.2	131	93.8	40	15	60.5	42.2	23.5	-	20	59.8
KF40	150	28	150	188.5	167	103.3	40	20	69.5	51.6	26.5	120	20	60.8
KF50	175	33	180	220.2	202	121	40	23	90.5	62.3	32.5	120	40	69

Series	FA	FB	FC	FD	FT	FS	TA	TB	TE	TF	TG	TH	TJ	TK
KF16	17.7	29	16.5	-	56	19	-	-	-	-	-	-	-	-
KF25	26.5	39	24	14 <sup>G7</sup>	75	24.7	5	12.1	2.3	6.9	M5	11.5	4	32
KF32	34	53.8	34	25 <sup>G7</sup>	86.5	24.7	5	12.1	1.8	6.4	M5	11.5	4	47
KF40	42.5	56.8	41	25 <sup>G7</sup>	104	26	6	12.8	1.8	8.4	M6	17	5.5	55
KF50	52	65	50	25 <sup>G7</sup>	134	38	8	21.1	4.5	12.5	M8	23	7.5	72

### Permissible Unsupported Length OSP-P KF16 to KF50

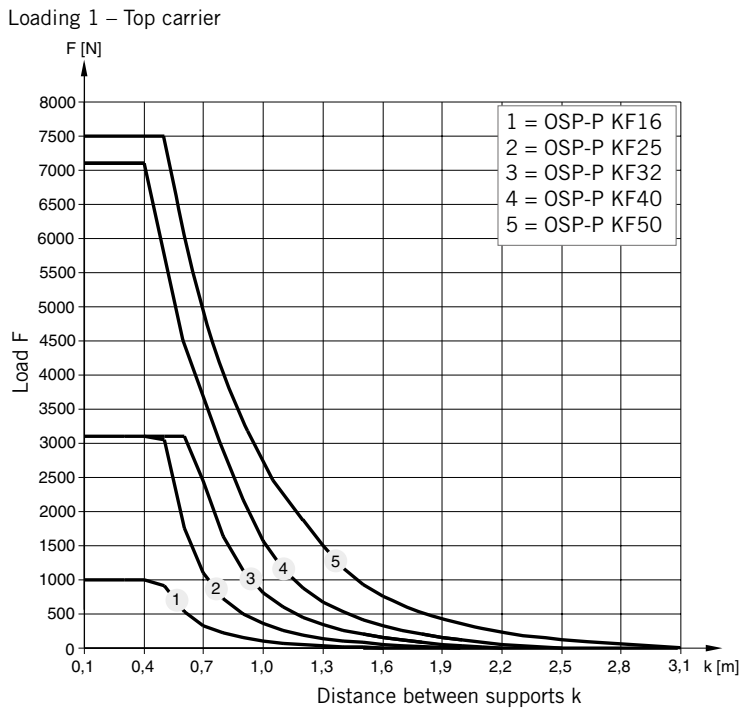

### Permissible Unsupported Length OSP-P KF16 to KF50

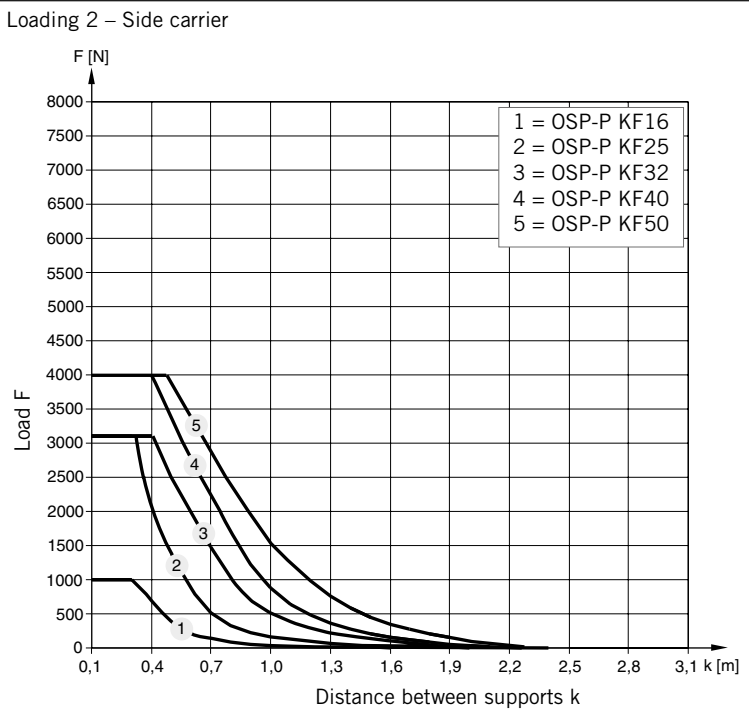

## Mid-Section Support

(For versions, see page 111, 114-115)  
 Mid-section supports are required from a certain stroke length to prevent excessive deflection and vibration of the linear drive. The diagrams show the maximum permissible unsupported length in relation to loading. A distinction must be drawn between loading 1 and loading 2.  
 Deflection of 0,5 mm max. between supports is permissible.

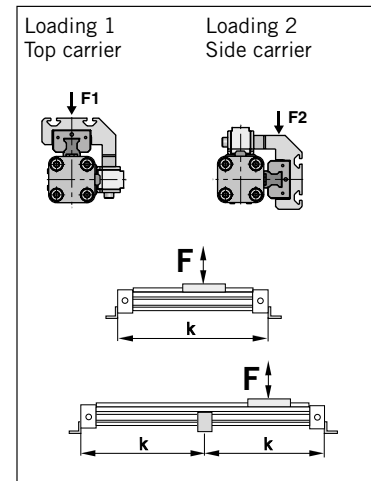

**Note:**

For speeds  $v > 0.5$  m/s the distance between supports should not exceed 1 m.

The right to introduce technical modifications is reserved

## Variable Stop

The variable stop Type VS provides simple stroke limitation. It can be retrofitted and positioned anywhere along the stroke length. For every cylinder diameter two types of shock absorber are available – see „Shock Absorber Selection“ below. Mid-section supports and magnetic switches can still be fitted on the same side as the variable stop. Depending on the application, two variable stops can be fitted if required.

### Variable Stop Type VS16 to VS50

Arrangement with two variable stops

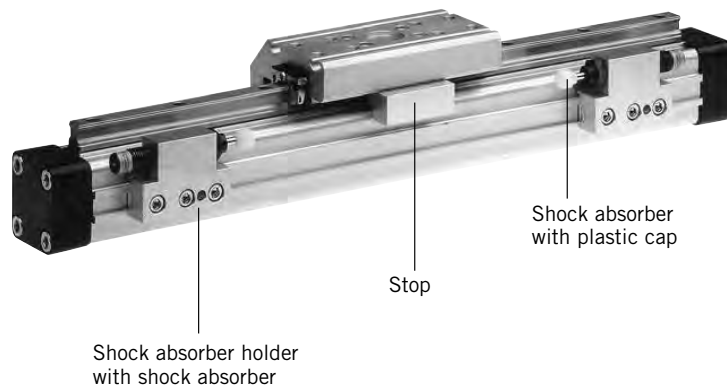

## Shock Absorber Selection

The shock absorber is selected in dependence on the mass and speed. The mass of the carrier itself must be taken into account.

### Shock Absorber Selection in Dependence on Mass and Speed for Series OSP-KF16

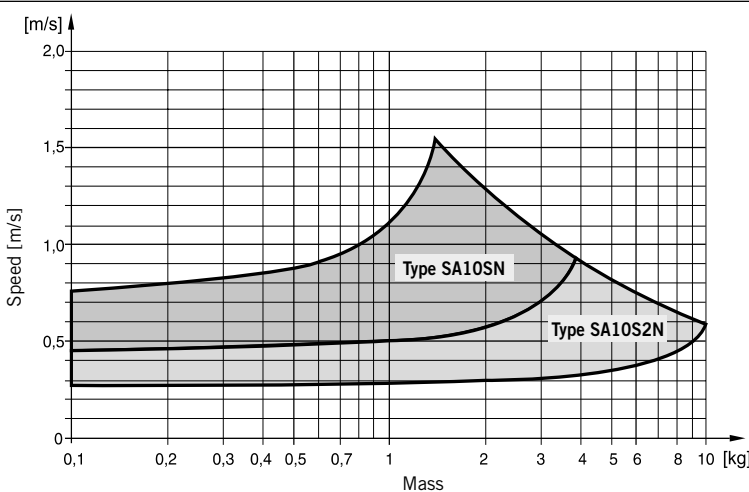

The values relate to an effective driving force of 78 N (6 bar)

### Shock Absorber Selection in Dependence on Mass and Speed for Series OSP-KF25

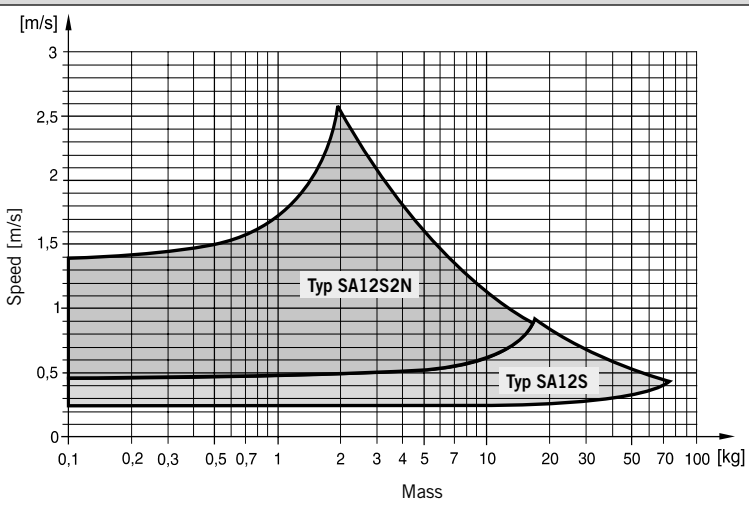

The values relate to an effective driving force of 250 N (6 bar)

**Shock Absorber Selection in Dependence on Mass and Speed for Series OSP-KF32**

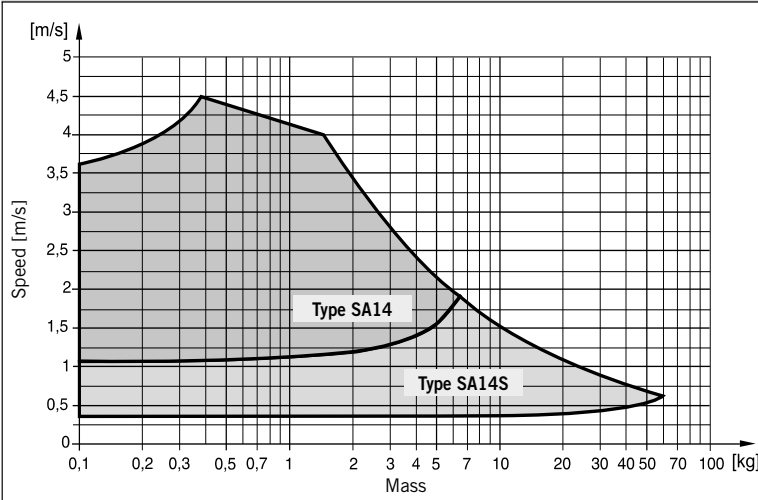

The values relate to an effective driving force of 420 N (6 bar)

**Shock Absorber Selection in Dependence on Mass and Speed for Series OSP-KF40**

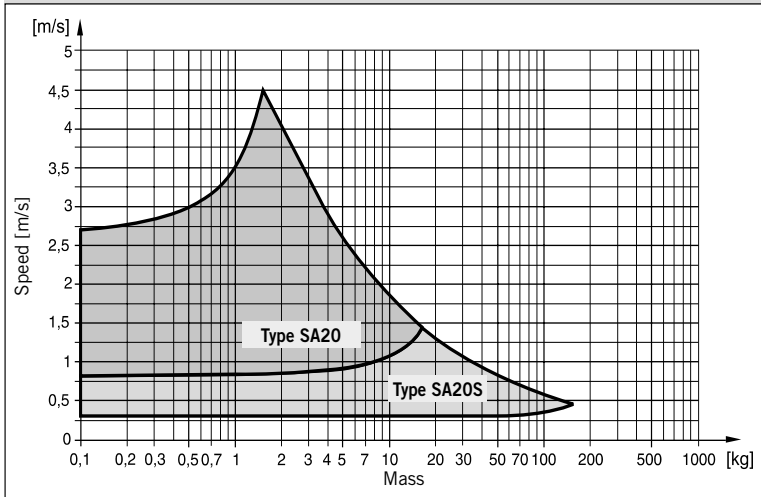

The values relate to an effective driving force of 640 N (6 bar)

**Shock Absorber Selection in Dependence on Mass and Speed for Series OSP-KF50**

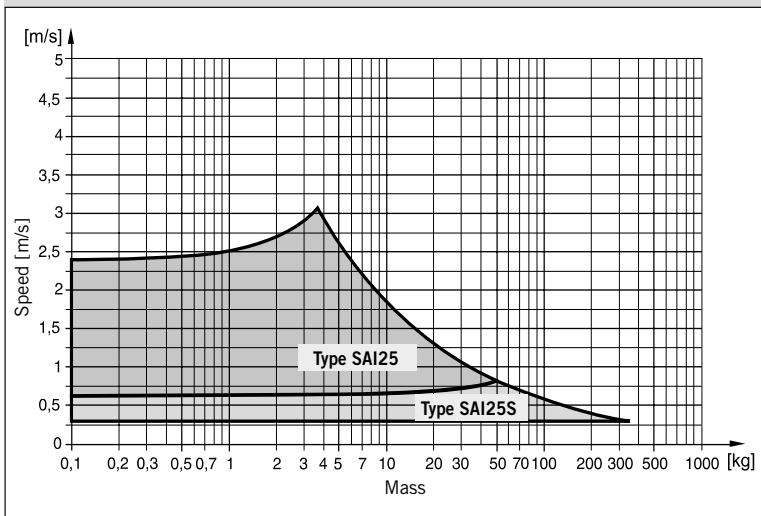

The values relate to an effective driving force of 1000 N (6 bar)

The right to introduce technical modifications is reserved

**Dimensions – Variable Stop Type VS16 to VS50**

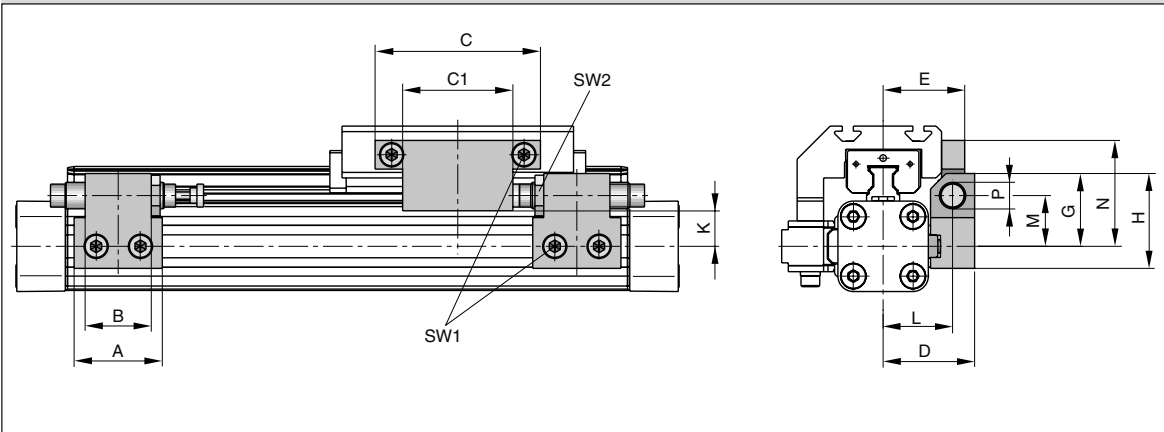

**Dimension Table [mm] – Variable Stop Type VS16 to VS50**

Series	Type	A	B	C	C1	D	E	G	H	K	L	M	N	P	SW1	SW2
OSP-KF16	VS16	30	14	50	25	33	29.7	28	38	16.2	25.5	20.5	40.5	M10 x 1	4	12.5
OSP-KF25	VS25	40	30	75	50	41.5	37	33	43	18	31.5	23	48	M12 x 1	5	16
OSP-KF32	VS32	60	40	50	-	45.5	41.5	35	45	19	35.5	25	37	M14 x 1.5	5	17
OSP-KF40	VS40	84	52	60	-	64	59	48	63	25.5	50	34	43	M20 x 1.5	5	24
OSP-KF50	VS50	84	-	60	-	75	69	55	70	26.9	57	38	58	M25 x 1.5	5	30

**Order Information – Variable Stop Type VS16 to VS50**

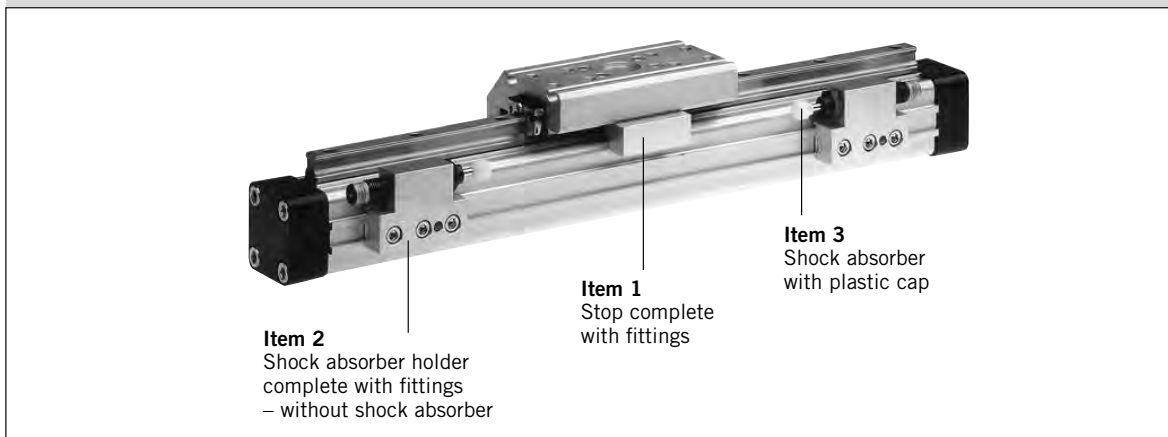

**Order Instructions – Variable Stop Type VS16 to VS50**

without cylinder and without guide

Item	Description	VS16		VS25		VS32		VS40		VS50	
		Type	Order No.	Type	Order No.	Type	Order No.	Type	Order No.	Type	Order No.
1	Stop, complete	-	21186FIL	-	21187FIL	-	21188FIL	-	21189FIL	-	21190FIL
2	Shock absorber holder, complete	-	21201FIL	-	21202FIL	-	21203FIL	-	21204FIL	-	21205FIL
3*	Shock absorber, soft	SA10SN	7718FIL	SA12S2N	7723FIL	SA14	7708FIL	SA20	7930FIL	SAI25	7712FIL
	Shock absorber, hard	SA10S2N	7721FIL	SA12S	7707FIL	SA14S	7709FIL	SA20S	7711FIL	SAI25S	7713FIL

\* Shock absorber with plastic cap

**Note:** Order instructions for VS in combination with the cylinder and guide see page 77, pos. 18

Order Instructions – KF																
1-4	5+6	7	8	9	10	11	12-16	17	18	19	20	21	22	23	24	25
OSPP	25	C	0	0	0	0	01100	0	0	0	C	0	0	0	0	0

Piston-Ø
16
25
32
40
50

Stroke
Input in mm (5 digits)

Piston Mounting
0 without

Measuring system
0 without
X SFI 0.1 mm
Y SFI 1 mm

Screws
0 standard

Cushioning
0 standard
1 max. length <sup>3)</sup>
2 VS variable stop, soft left for KF
3 VS variable stop, hard, left for KF
4 VS variable stop, soft, right for KF
5 VS variable stop, hard, right for KF
6 VS variable stop, soft, both sides for KF
7 VS variable stop, hard, both sides for KF

Cover / Cable Channel
0 standard
1 cable channel
2 cable channel two-sided
X without Cover rail

Version / Piston
C Classic
T Classic Tandem

Lubrication
0 standard
1 Slow speed <sup>2)3)</sup>

Air Connection
0 standard
1 on the end face
2 both at one end (not turnable)
3 left standard right end face
4 right standard left end face
A 3/2 way valve VOE 24 V= Ø 25,32,40, 50
B 3/2 way valve VOE 230 V~/110 V= Ø 25, 32, 40, 50
C 3/2 way valve VOE 48 V= Ø 25, 32, 40, 50
E 3/2 way valve VOE 110 V~ Ø 25, 32, 40, 50

Seals
0 standard (NBR)
1 Viton <sup>® 1)</sup>

End cap position
0 L + R 0° = in front
1 L + R 90° = underneath
2 L + R 180° = at the back
3 L + R 270° = same side as outerband
4 L 90° = underneath; R 0° = in front
5 L 180° = at the back; R 0° = in front
6 L 270° = same side as outerband; R 0° = in front
7 L 0° = in front; R 90° = underneath
8 L 180° = at the back; R 90° = underneath
9 L 270° = same side as outerband; R 90° = underneath
A L 0° = in front; R 180° = at the back
B L 90° = underneath; R 180° = at the back
C L 270° = same side as outerband; R 180° = at the back
D L 0° = in front; R 270° = same side as outerband
E L 90° = underneath; R 270° = same side as outerband
F L 180° = at the back; R 270° = same side as outerband

Guides/ Brakes
C KF

add. Guide Carriage
0 without
C Guide Carriage KF

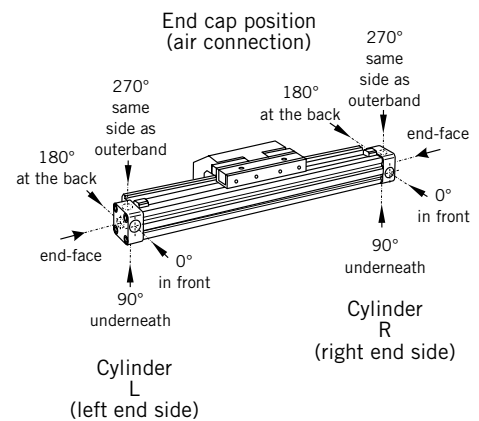

1) Viton with VOE not possible.  
 2) "Slow speed lubrication" in combination with „Viton<sup>®</sup>“ seals on demand.  
 3) „Lubrication slow speed“ in combination with „max. cushioning length“ not possible.

The right to introduce technical modifications is reserved



Version with pneumatic linear drive series OSP-P

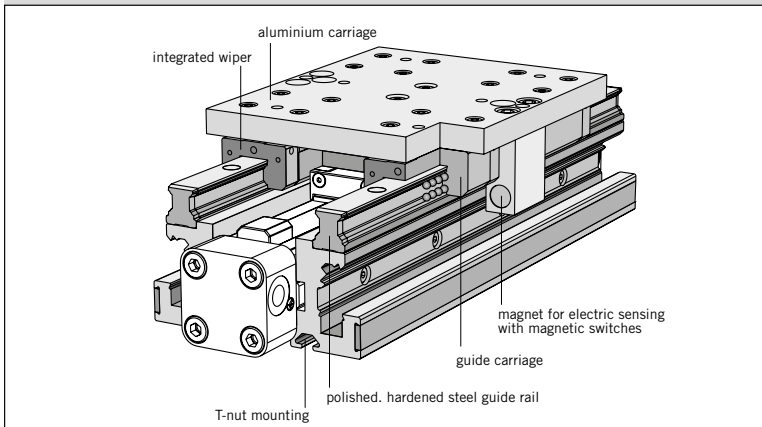

# Heavy Duty-Guide HD



Series HD 25 to 50  
for Linear Drive Series OSP-P

Loads. Forces and Moments

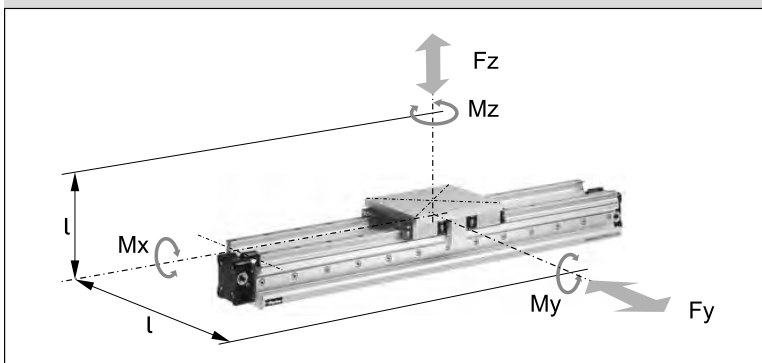

Technical Data

The table shows the maximum permissible loads. If multiple moments and forces act upon the cylinder simultaneously, the following equation applies:

$$\frac{M_x}{M_{x_{max}}} + \frac{M_y}{M_{y_{max}}} + \frac{M_z}{M_{z_{max}}} + \frac{F_y}{F_{y_{max}}} + \frac{F_z}{F_{z_{max}}} \leq 1$$

The sum of the loads should not >1

The table shows the maximum permissible values for light, shock-free operation, which must not be exceeded even under dynamic conditions.

**\* Please note:**  
The mass of the carriage does not have to be added to the total moving mass when using the cushioning diagram.

Features:

- Guide system: 4-row recirculating ball bearing guide
- Polished and hardened steel guide rail
- For highest loads in all directions
- Highest precision
- Integrated wiper system
- Integrated grease nipples
- Any lengths of stroke up to 3700 mm (longer strokes on request)
- Anodized aluminium guide carriage - dimensions compatible with OSP guide GUIDELINE
- Maximum speed  $v = 5 \text{ m/s}$

Options:

- With variable stop
- With intermediate stop module



Series	For linear drive	Max. moment [Nm]			Max. loads [N]		Mass of linear drive with guide carriage [kg]		Mass * guide [kg]	Order-No. ** HD Guide without cylinder
		Mx	My	Mz	Fy	Fz	with 0 mm stroke	increase per 100 mm stroke		
HD 25	OSP-P25	260	320	320	6000	6000	3.065	0.924	1.289	21246
HD 32	OSP-P32	285	475	475	6000	6000	4.308	1.112	1.367	21247
HD 40	OSP-P40	800	1100	1100	15000	15000	7.901	1.748	2.712	21248
HD 50	OSP-P50	1100	1400	1400	18000	18000	11.648	2.180	3.551	21249

\*\* Please use this order pattern: Order-No. + „stroke in mm“ (5 digits)  
Example: HD Guide D25 mm, stroke 1000 mm: 21246-01000

For linear drives see page 9-13

The right to introduce technical modifications is reserved

## Dimensions

### Series OSP-P

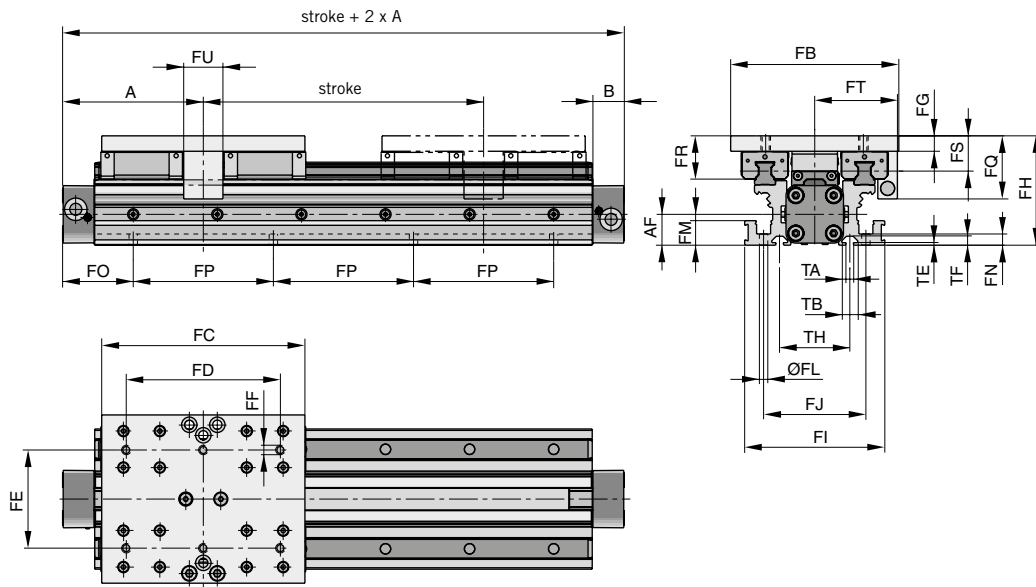

#### Note:

The HD heavy duty guide must be mounted on a flat surface for its entire length.

If T-grooves or T-bolts are used, the distance between them should not exceed 100 mm.

#### Variable Stop Type VS25 to VS50

The variable stop provides simple stroke limitation and can be supplied mounted on the right or left, as required.

For further information see following data sheets:

For dimensions and order instructions see page 82

For shock absorber selection see page 66, 67

#### Incremental displacement measuring system ORIGA-Sensoflex Series SFI-plus

can be supplied mounted on the right or left, as required.

For further information see page 129-133.

#### Arrangement of magnetic switches:

Magnetic switches can be fitted anywhere on either side.

For further information see following data sheets:

Magnetic Switches see page 123-126  
Cable Cover see page 127.

Linear Drives OSP-P see from page 15

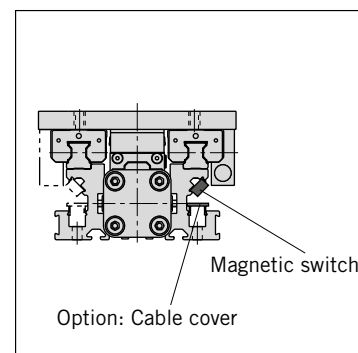
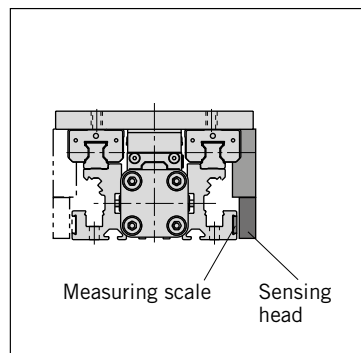
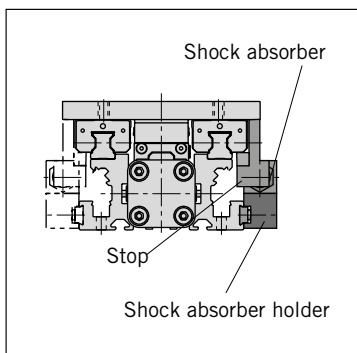

**Dimension Table [mm]**

Series	A	B	AF	FB	FC	FD	FE	FF	FG	FH	FI	FJ	ØFL
HD25	100	22	22	120	145	110	70	M6	11	78	100	73	6
HD32	125	25.5	30	120	170	140	80	M6	11	86	112	85	6
HD40	150	28	38	160	180	140	110	M8	14	108	132	104	7.5
HD50	175	33	48	180	200	160	120	M8	14	118	150	118	7.5

Series	FM	FN	FP	FQ	FR	FS	FT	FU	TA	TB	TE	TF	TH
HD25	17.5	8	100	45	31	25	59	28	5.2	11.5	1.8	6.4	50
HD32	17.5	8	100	45	31	25	63	30	5.2	11.5	1.8	6.4	60
HD40	22	10	100	58	40	31.5	76	30	8.2	20	4.5	12.3	66
HD50	22	10	100	58	44	35.5	89	30	8.2	20	4.5	12.3	76

FO				
OSP-P				
x	HD25	HD32	HD40	HD50
00	50.0	75.0	50.0	75.0
01	50.5	75.5	50.5	75.5
02	51.0	76.0	51.0	76.0
03	51.5	76.5	51.5	76.5
04	52.0	77.0	52.0	77.0
05	52.5	77.5	52.5	77.5
06	53.0	78.0	53.0	78.0
07	53.5	78.5	53.5	78.5
08	54.0	79.0	54.0	79.0
09	54.5	79.5	54.5	79.5
10	55.0	80.0	55.0	80.0
11	55.5	80.5	55.5	80.5
12	56.0	81.0	56.0	81.0
13	56.5	81.5	56.5	81.5
14	57.0	82.0	57.0	82.0
15	57.5	82.5	57.5	82.5
16	58.0	83.0	58.0	83.0
17	58.5	83.5	58.5	83.5
18	59.0	84.0	59.0	84.0
19	59.5	84.5	59.5	84.5
20	60.0	85.0	60.0	85.0
21	60.5	85.5	60.5	85.5
22	61.0	86.0	61.0	86.0
23	61.5	86.5	61.5	86.5
24	62.0	87.0	62.0	87.0
25	62.5	87.5	62.5	87.5
26	63.0	88.0	63.0	88.0
27	63.5	88.5	63.5	88.5
28	64.0	89.0	64.0	89.0
29	64.5	89.5	64.5	89.5
30	65.0	90.0	65.0	90.0
31	65.5	90.5	65.5	90.5
32	66.0	91.0	66.0	91.0
33	66.5	91.5	66.5	91.5
34	67.0	92.0	67.0	92.0
35	67.5	92.5	67.5	92.5
36	68.0	93.0	68.0	93.0
37	68.5	93.5	68.5	93.5
38	69.0	94.0	69.0	94.0
39	69.5	94.5	69.5	94.5
40	70.0	95.0	70.0	95.0
41	70.5	95.5	70.5	95.5
42	71.0	96.0	71.0	96.0
43	71.5	96.5	71.5	96.5
44	72.0	97.0	72.0	97.0
45	72.5	97.5	72.5	97.5
46	73.0	98.0	73.0	98.0
47	73.5	98.5	73.5	98.5
48	74.0	99.0	74.0	99.0
49	74.5	99.5	74.5	99.5

FO				
OSP-P				
x	HD25	HD32	HD40	HD50
50	75.0	50.0	75.0	50.0
51	75.5	50.5	75.5	50.5
52	76.0	51.0	76.0	51.0
53	76.5	51.5	76.5	51.5
54	77.0	52.0	77.0	52.0
55	77.5	52.5	77.5	52.5
56	78.0	53.0	78.0	53.0
57	78.5	53.5	78.5	53.5
58	79.0	54.0	79.0	54.0
59	79.5	54.5	79.5	54.5
60	80.0	55.0	80.0	55.0
61	80.5	55.5	80.5	55.5
62	81.0	56.0	81.0	56.0
63	81.5	56.5	81.5	56.5
64	82.0	57.0	82.0	57.0
65	82.5	57.5	82.5	57.5
66	83.0	58.0	83.0	58.0
67	83.5	58.5	83.5	58.5
68	84.0	59.0	84.0	59.0
69	84.5	59.5	84.5	59.5
70	85.0	60.0	85.0	60.0
71	85.5	60.5	85.5	60.5
72	86.0	61.0	86.0	61.0
73	86.5	61.5	86.5	61.5
74	87.0	62.0	87.0	62.0
75	87.5	62.5	87.5	62.5
76	88.0	63.0	88.0	63.0
77	88.5	63.5	88.5	63.5
78	89.0	64.0	89.0	64.0
79	89.5	64.5	89.5	64.5
80	90.0	65.0	90.0	65.0
81	90.5	65.5	90.5	65.5
82	91.0	66.0	91.0	66.0
83	91.5	66.5	91.5	66.5
84	92.0	67.0	92.0	67.0
85	92.5	67.5	92.5	67.5
86	93.0	68.0	93.0	68.0
87	93.5	68.5	93.5	68.5
88	94.0	69.0	94.0	69.0
89	94.5	69.5	94.5	69.5
90	95.0	70.0	95.0	70.0
91	95.5	70.5	95.5	70.5
92	96.0	71.0	96.0	71.0
93	96.5	71.5	96.5	71.5
94	97.0	72.0	97.0	72.0
95	97.5	72.5	97.5	72.5
96	98.0	73.0	98.0	73.0
97	98.5	73.5	98.5	73.5
98	99.0	74.0	99.0	74.0
99	99.5	74.5	99.5	74.5

**Note:**  
the dimension FO is derived from the last two digits of the stroke:

**Example:**

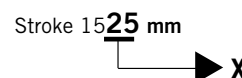

For a cylinder OSP-P25 the adjacent table indicates that for x = 25 mm: FO = 62.5 mm

The right to introduce technical modifications is reserved

### Dimensions – Variable Stop Type VS25 to VS50

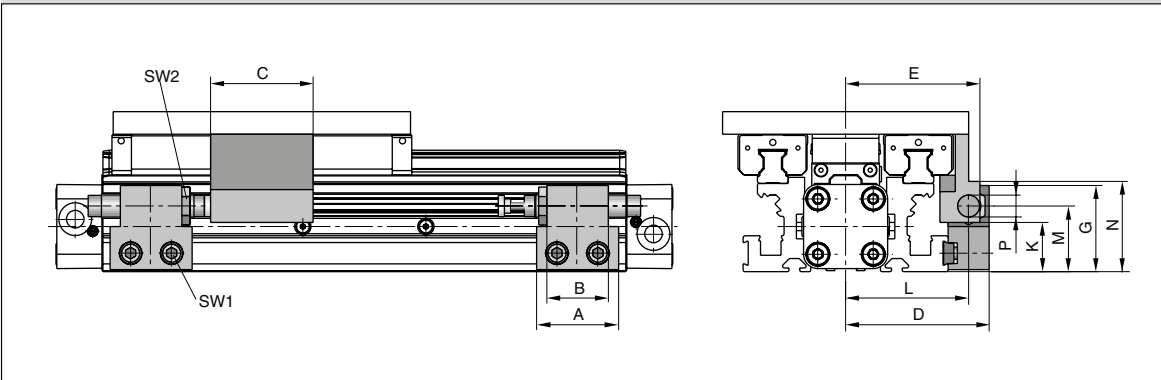

### Dimension Table [mm] – Variable Stop Type VS25 to VS50

Series	Type	A	B	C	D	E	G	K	L	M	N	P	SW1	SW2
OSP-HD25	VS25	40	30	50	70	65.5	42	26	60	32	42	M12 x 1	5	16
OSP-HD32	VS32	60	40	54	73	71	44	28	63	34	53	M14 x 1.5	5	17
OSP-HD40	VS40	84	52	55	96	92	59	35	82	45	61	M20 x 1.5	5	24
OSP-HD50	VS50	84	-	60	107	105	66	37	89	49	66	M25 x 1.5	5	30

### Order Information – Variable Stop Type VS25 to VS50

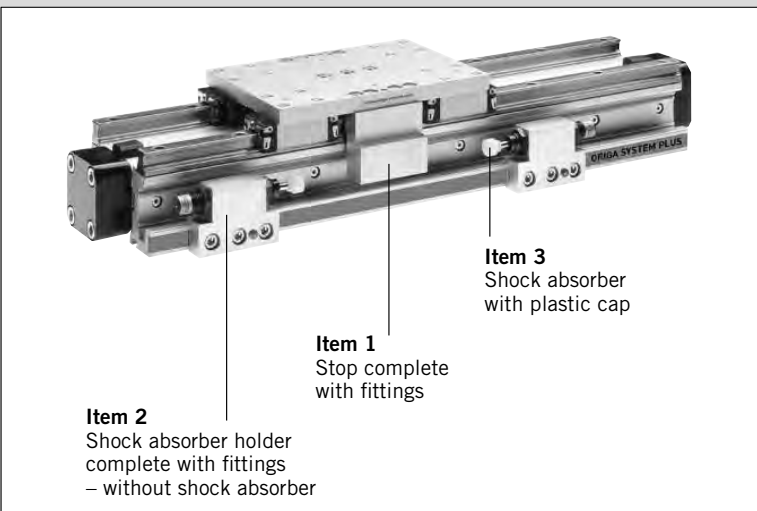

### Shock Absorber Selection

For shock absorber selection in dependence on mass and speed see page 66, 67.

### Order Instructions – Variable Stop Type VS25 to VS50

without cylinder and HD-guide

Item	Description	Size							
		VS25		VS32		VS40		VS50	
		Type	Order-No.	Type	Order-No.	Type	Order-No.	Type	Order-No.
1	Stop, complete	-	21257FIL	-	21258FIL	-	21259FIL	-	21260FIL
2	Shock absorber holder, complete	-	21202FIL	-	21203FIL	-	21204FIL	-	21205FIL
3*	Shock absorber, soft	SA12S2N	7723FIL	SA14	7708FIL	SA20	7930FIL	SAI25	7712FIL
	Shock absorber, hard	SA12S	7707FIL	SA14S	7709FIL	SA20S	7711FIL	SAI25S	7713FIL

\* Shock absorber with plastic cap (see page 66, 67)

**Note:** Order instructions for VS in combination with the HD Guide see page 86, pos. 18

### Intermediate stop module Type ZSM..HD

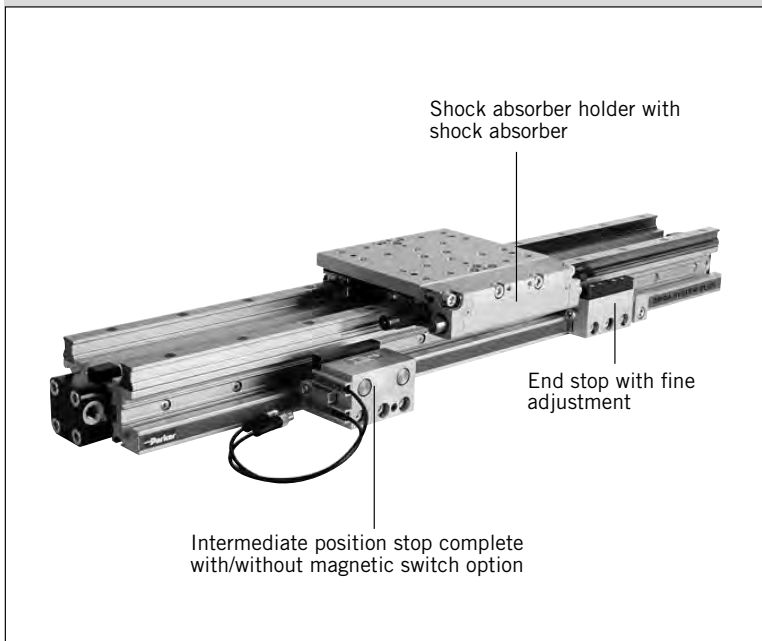

## Intermediate stop module

The intermediate stop module ZSM allows the guide carriage to stop at any desired intermediate positions with high accuracy. It can be retrofitted. Depending on the application, i.e. the number of intermediate stops, one or more intermediate position stops can be used. The intermediate position stops can be retracted and extended without the need for the guide carriage to be moved back out of position. Therefore the guide carriage can be made to stop at the defined intermediate positions in any order.

#### ORIGA intermediate stop module ZSM:

- Allows stopping at any intermediate positions
- Intermediate position stops can be located steplessly anywhere along the whole stroke length
- Movement to the next position without reverse stroke
- Compact unit
- Cost-effective positioning module without electrical or electronic components
- Option: end stop with fine adjustment

#### Technical data

Temperature range	-10°C to +70°C
Operating pressure range	4 – 8 bar
Intermediate position grid	85 mm

### Shock Absorber Type SA14S

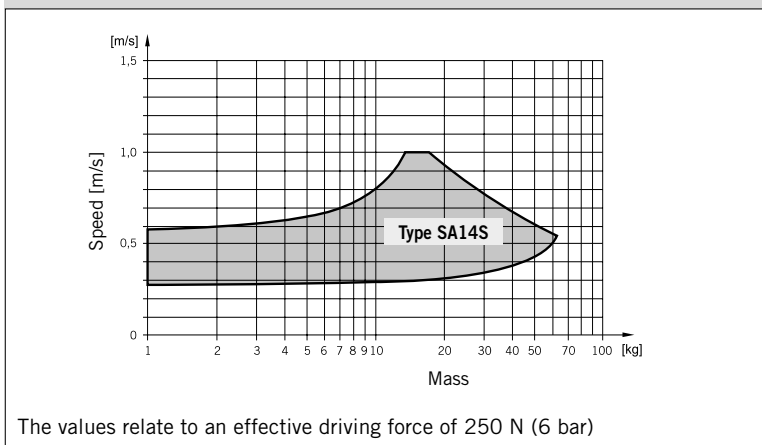

The right to introduce technical modifications is reserved

### Dimensions – intermediate stop module Type ZSM..HD

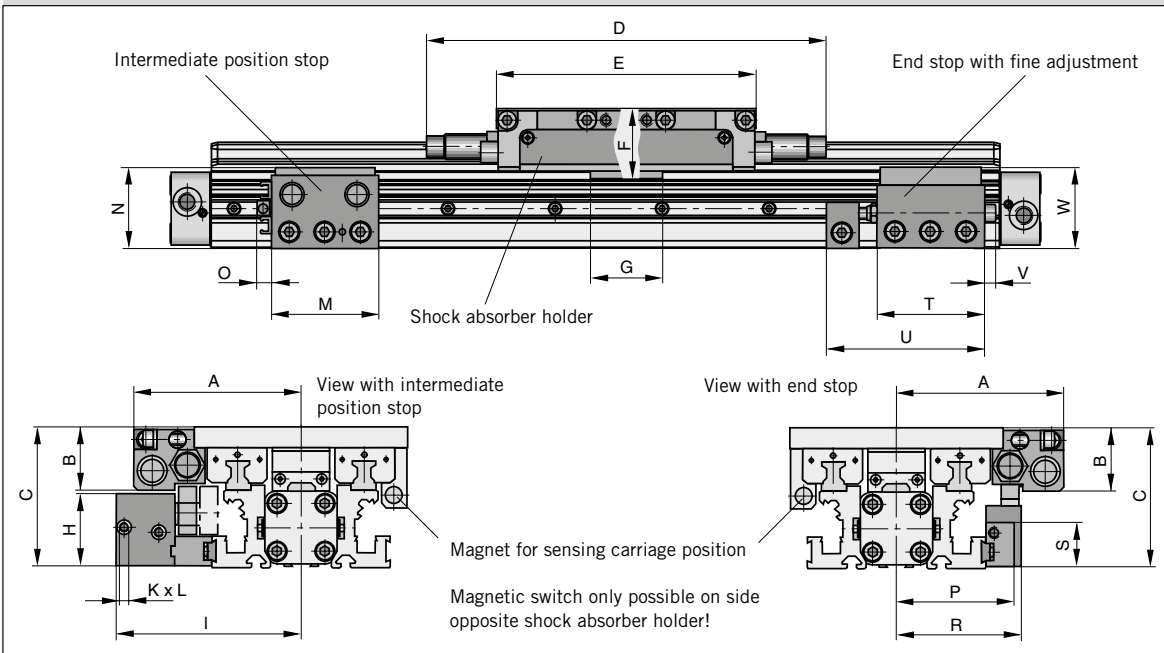

### Dimension table [mm] – intermediate stop module Type ZSM..HD

Series	A	B	C	D	E	F	G	H	I	K	L	M	N	O	P	R	S	T	U	V	W
ZSM25	94	35	78	224	145	39	40	41	104	M5	5	60	45	8	66	70	26	60	93	6	46

### Shock absorber arrangement in dependence on direction of movement

#### From right to left

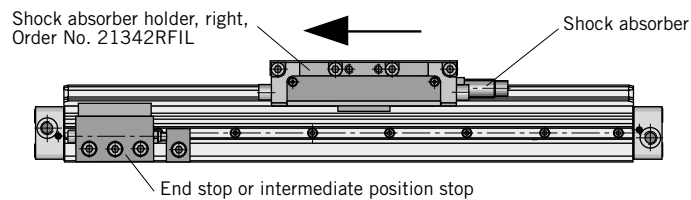

#### In both directions

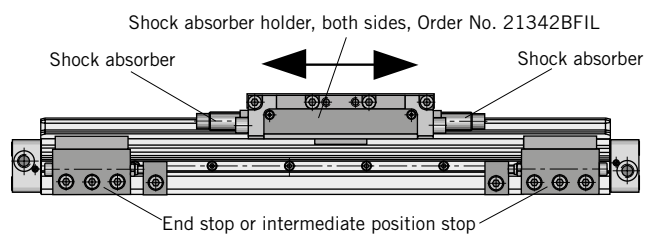

#### From left to right

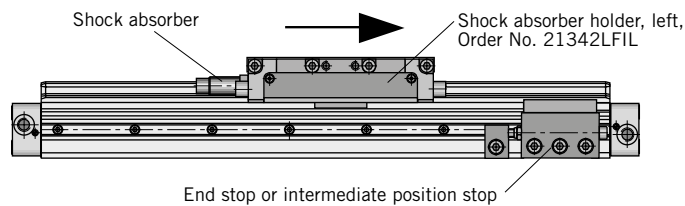

**Order instructions – intermediate stop module Type ZSM..HD**

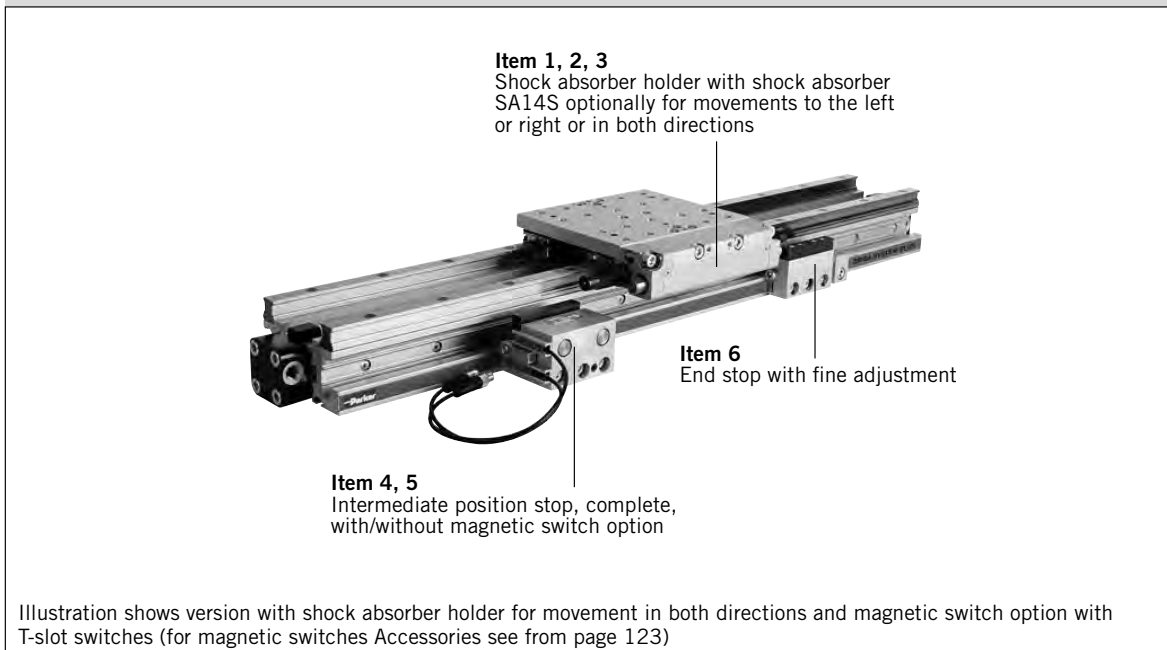

**Order instructions – intermediate stop module Type ZSM..HD**

Item	Description	For intermediate stop module	Order-No.
1*	Shock absorber holder with shock absorber SA14S, both sides	ZSM25HD	21342BFIL
2*	Shock absorber holder with shock absorber SA14S, left	ZSM25HD	21342LFIL
3*	Shock absorber holder with shock absorber SA14S, right	ZSM25HD	21342RFIL
4	Intermediate position stop complete, without magnetic switch option	ZSM25HD	21343FIL
5	Intermediate position stop complete, with magnetic switch option	ZSM25HD	21344FIL
6	End stop with fine adjustment	ZSM25HD	21346FIL

\* The shock absorbers are installed in the shock absorber holder and adjusted in our workshop.

**Note:**

**For movement onwards from the intermediate position, the intermediate position stop must advance. The intermediate position stop can only advance if both cylinder chambers of the OSP-P cylinder are pressurized.**

The right to introduce technical modifications is reserved

**Order Instructions – HEAVY DUTY - HD**

1-4	5+6	7	8	9	10	11	12-16	17	18	19	20	21	22	23	24	25
OSPP	25	0	0	0	0	0	01100	0	0	0	D	0	0	0	0	0

Piston-Ø
25
32
40
50

Stroke
Input in mm (5 digits)

Piston Mounting
0 without

Measuring system
0 without
X SFI 0.1 mm
Y SFI 1 mm

Screws
0 standard

Cushioning
0 standard
1 max. length <sup>3)</sup>
2 VS variable stop, soft left for HD
3 VS variable stop, hard, left for HD
4 VS variable stop, soft, right for HD
5 VS variable stop, hard, right for HD
6 VS variable stop, soft, both sides for HD
7 VS variable stop, hard, both sides for HD

Cover / Cable Channel
0 standard
1 cable channel
2 cable channel two-sided
X without Coverrail

Version / Piston
0 standard
1 Tandem

Lubrication
0 standard
1 Slow speed <sup>2)3)</sup>

Air Connection
0 standard
1 on the end face
2 both at one end (not turnable)
3 left standard right end face
4 right standard left end face
A 3/2 way valve VOE 24 V = Ø25, 32, 40, 50
B 3/2 way valve VOE 230 V~/110 V= Ø25, 32, 40, 50
C 3/2 way valve VOE 48 V= Ø25, 32, 40, 50
E 3/2 way valve VOE 110 V~ Ø25, 32, 40, 50

Seals
0 standard (NBR)
1 Viton <sup>®1)</sup>

End cap position
0 L + R 0° = in front
1 L + R 90° = underneath
2 L + R 180° = at the back
3 L + R 270° = same side as outerband
4 L 90° = underneath; R 0° = in front
5 L 180° = at the back; R 0° = in front
6 L 270° = same side as outerband; R 0° = in front
7 L 0° = in front; R 90° = underneath
8 L 180° = at the back; R 90° = underneath
9 L 270° = same side as outerband; R 90° = underneath
A L 0° = in front; R 180° = at the back
B L 90° = underneath; R 180° = at the back
C L 270° = same side as outerband; R 180° = at the back
D L 0° = in front; R 270° = same side as outerband
E L 90° = underneath; R 270° = same side as outerband
F L 180° = at the back; R 270° = same side as outerband

Guides
D HD

add. Guide Carriage
0 without
D Guide Carriage HD

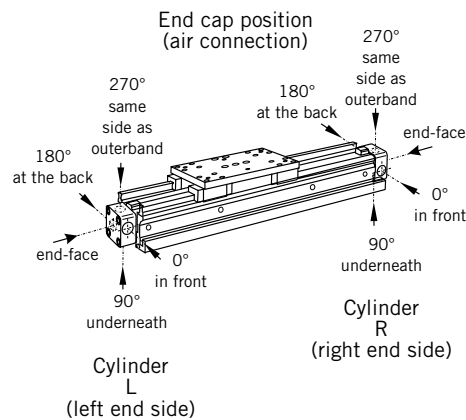

- 1) Viton with VOE not possible.
- 2) "Slow speed lubrication" in combination with „Viton<sup>®</sup>“ seals on demand.
- 3) „Lubrication slow speed“ in combination with „max. cushioning length“ not possible.

# Active and Passive Brakes Series OSP-P



## Contents

Description	Page
Overview	88
Standard cylinder with Active brake	89-92
Plain bearing SLIDELINE with Active brake	49-51
Aluminium roller guide PROLINE with Active brake	59-61
Plain bearing SLIDELINE with Passive brake Multibrake	93-96
Aluminium roller guide PROLINE with Passive brake Multibrake	97-99

# OSP

— ORIGA  
— SYSTEM  
— PLUS

## Active Brakes and Passive Brakes

### Versions:

- ACTIVE Brake
- Plain bearing guide with integrated ACTIVE Brake
- Aluminium roller guide with integrated ACTIVE Brake
- Plain bearing guide with PASSIVE Brake
- Aluminium roller guide with PASSIVE Brake

**Active Brake**  
for pneumatic linear drive  
Series OSP-P  
Piston diameters 25 - 80 mm.

See page 89-92



**Slideline with Active Brake**  
Plain bearing guide SLIDELINE - SL  
with integrated ACTIVE Brake  
Piston diameters 25 - 50 mm.

See page 49-51



**Proline with Active Brake**  
Aluminium roller guide  
PROLINE - PL with  
integrated ACTIVE Brake  
Piston diameters 25 - 50 mm.

See page 59-61



**Multibrake with Slideline**  
MULTI BRAKE – PASSIVE Brake  
with plainbearing guide  
SLIDELINE - SL  
Piston diameter 25 - 80 mm.

See page 93-96

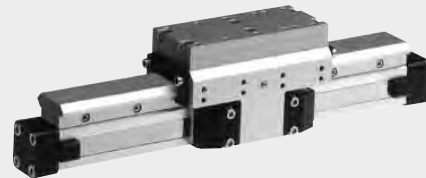

**Multibrake with Proline**  
MULTI BRAKE – PASSIVE Brake with  
aluminium roller guide  
PROLINE - PL  
Piston diameters 25 - 50 mm.

See page 97-99



**Function**

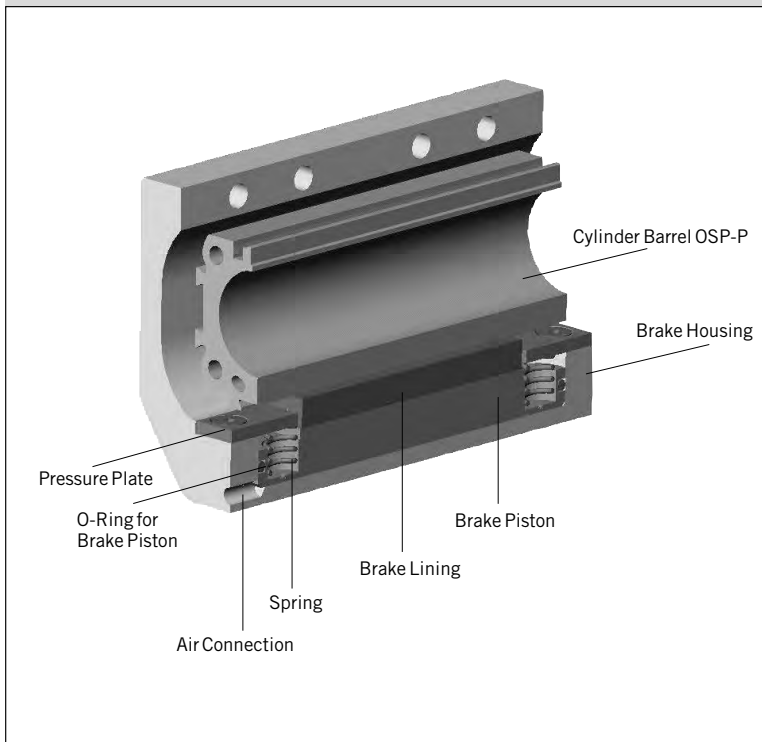

# Active Brake



**Series AB 25 to 80  
for linear drive**  
• Series OSP-P

**Features:**

- Actuated by pressurisation
- Released by spring actuation
- Completely stainless version
- Holds position, even under changing load conditions

For further technical data, please refer to the data sheets for linear drives OSP-P (see from page 15).

**Note:**

For combinations Active Brake AB + SFI-plus + Magnetic Switch contact our technical department please.

**Active brake in combination with Basic Cylinder see page 24, pos. 20**

**Forces and Weights**

Series	For linear drive	Max. braking force [N] <sup>1)</sup>	Brake pad way [mm]	Mass [kg]		Brake *
				Linear drive with brake 0 mm stroke	increase per 100 mm stroke	
<b>AB 25</b>	OSP-P25	350	2.5	1.0	0.197	0.35
<b>AB 32</b>	OSP-P32	590	2.5	2.02	0.354	0.58
<b>AB 40</b>	OSP-P40	900	2.5	2.83	0.415	0.88
<b>AB 50</b>	OSP-P50	1400	2.5	5.03	0.566	1.50
<b>AB 63</b>	OSP-P63	2170	3.0	9.45	0.925	3.04
<b>AB 80</b>	OSP-P80	4000	3.0	18.28	1.262	5.82

<sup>1)</sup> – at 6 bar  
both chambers pressurised with 6 bar  
Braking surface dry  
– oil on the braking surface will reduce the braking force

**\* Please Note:**  
The mass of the brake has to be added to the total moving mass when using the cushioning diagram.



**For additional information on loads, forces and moment, please refer from page 16**

The right to introduce technical modifications is reserved

Series OSP-P25 and P32 with Active Brake AB

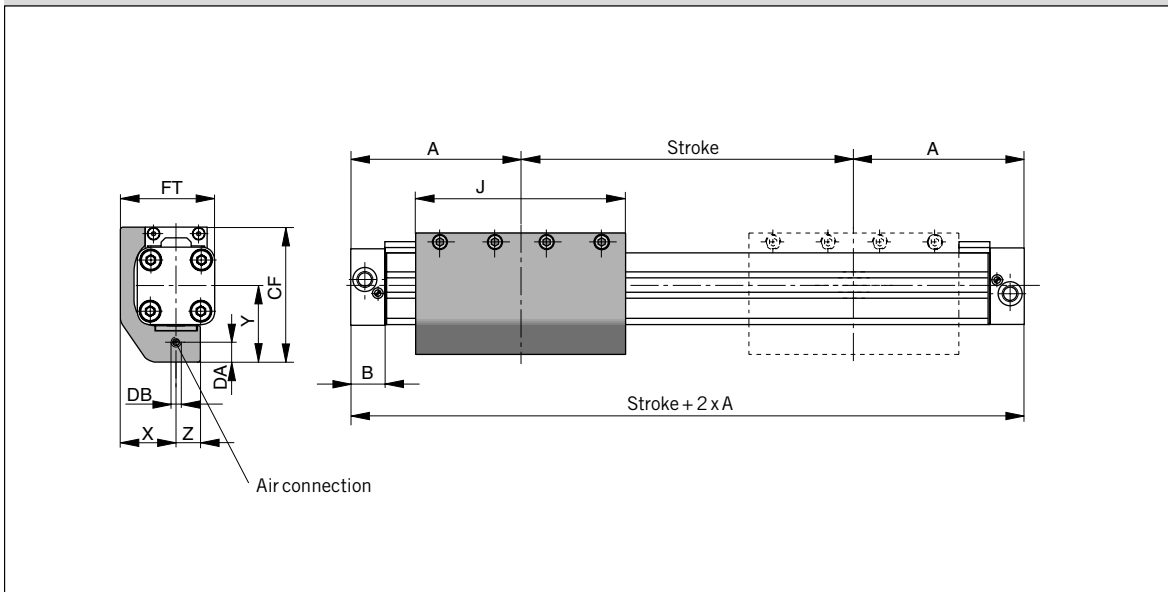

Series OSP-P40, P50, P63, P80 with Active Brake AB

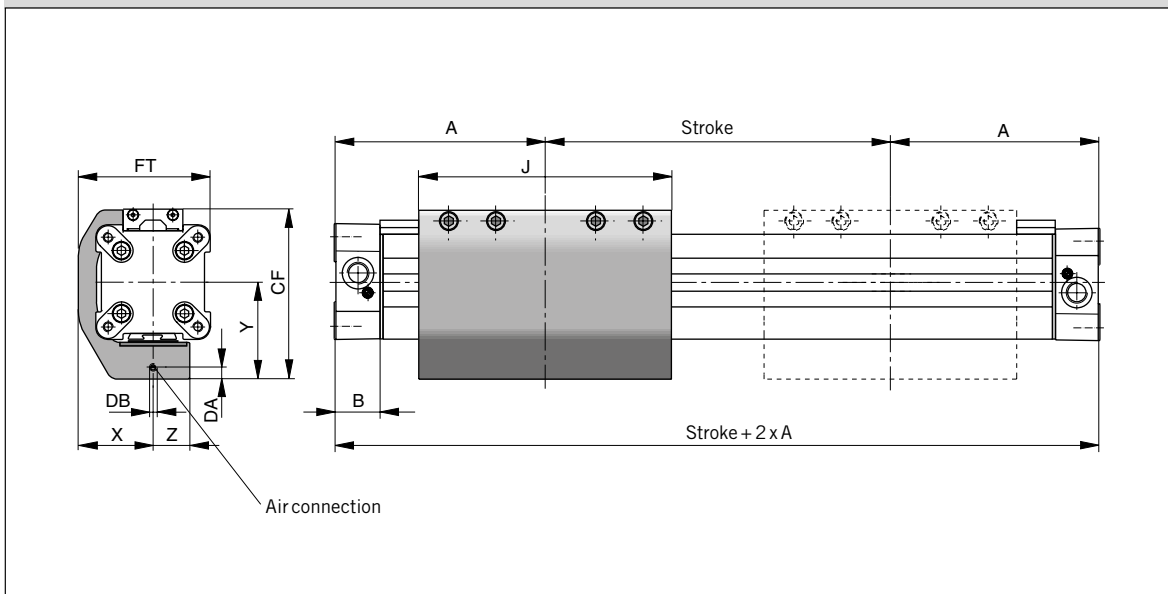

Dimension Table [mm]

Series	A	B	J	X	Y	Z	CF	DA	DB	FT
AB 25	100	22	117	29.5	43	13	74	4	M5	50
AB 32	125	25.5	151.4	36	50	15	88	4	M5	62
AB 40	150	28	151.4	45	58	22	102	7	M5	79.5
AB 50	175	33	200	54	69.5	23	118.5	7.5	M5	97.5
AB 63	215	38	256	67	88	28	151	9	G1/8	120
AB 80	260	47	348	83	105	32	185	10	G1/8	149

**Series OSP – P25 and P32 with Active Brake AB: Type A3**

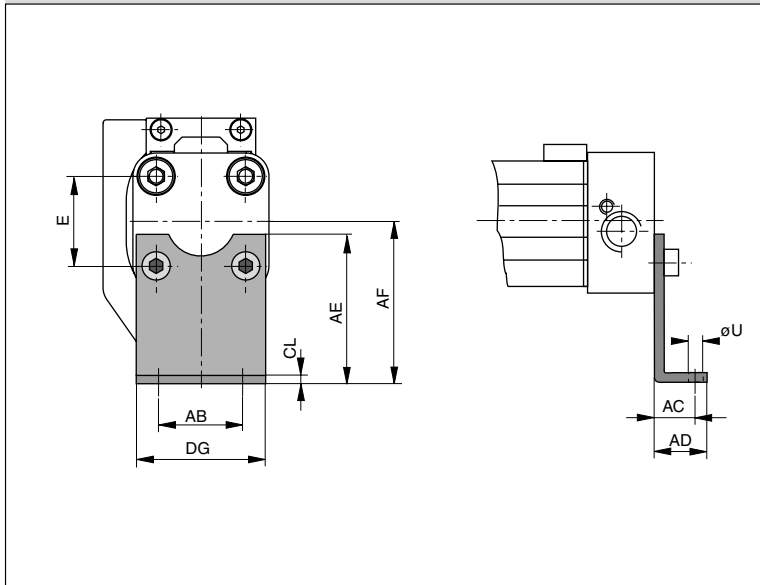

**End Cap Mountings**

On the end-face of each cylinder end cap there are four threaded holes for mounting the cylinder. The hole layout is square, so that the mounting can be fitted to the bottom, top or either side.

Material: Series OSP-P25, P32:  
Galvanised steel

The mountings are supplied in pairs.



**Series OSP – P40 , P50, P63, P80 with Active Brake AB: Type C3**

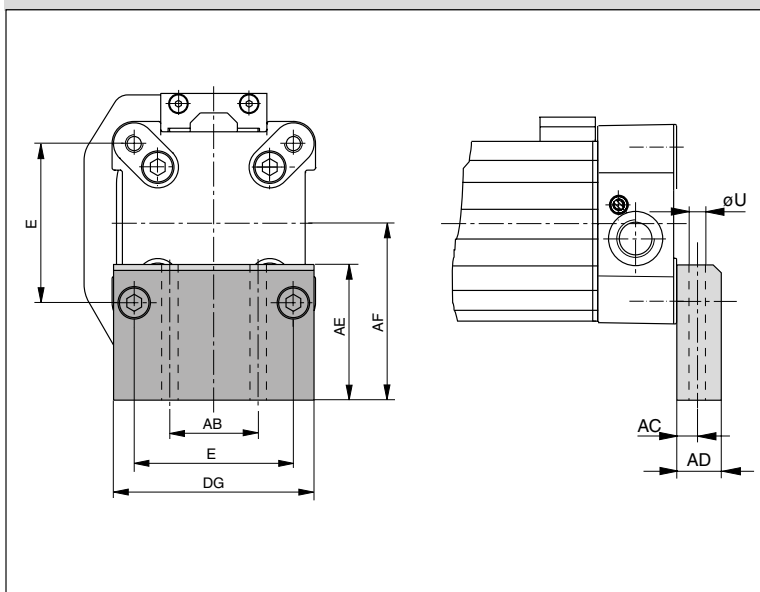

Material: Series OSP-  
P40, P50, P63, P80:  
Anodised aluminium

The mountings are supplied in pairs.

Stainless steel version on request.



**Dimension Table [mm]**

Series	E	øU	AB	AC	AD	AE	AF	CL	DG	Order No.	
										Type A3	Type C3
AB 25	27	5.8	27	16	22	45	49	2.5	39	2060FIL	–
AB 32	36	6.6	36	18	26	42	52	3	50	3060FIL	–
AB 40	54	9	30	12.5	24	46	60	–	68	–	20339FIL
AB 50	70	9	40	12.5	24	54	72	–	86	–	20350FIL
AB 63	78	11	48	15	30	76	93	–	104	–	20821FIL
AB 80	96	14	60	17.5	35	88	110	–	130	–	20822FIL

The right to introduce technical modifications is reserved

### Mid Section Support

Mid-section supports are required from a certain stroke length to prevent excessive deflection and vibration of the linear drive.

The diagrams show the maximum permissible unsupported length in relation to loading. Deflection of 0.5 mm max. between supports is permissible.

The mid section supports are attached to the dovetail rails, and can take axial loads.

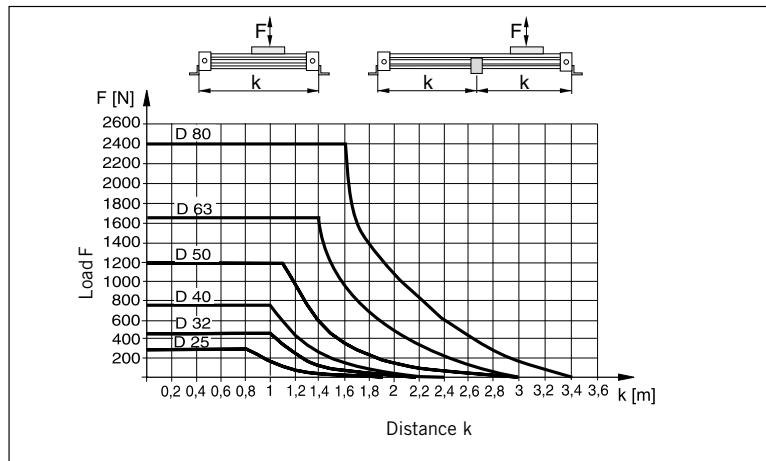

### Mid Section Supports

Note to Type E3:

Mid section supports can only be mounted opposite of the brake housing.

Stainless steel version available on request.



### Series OSP-P25 to P80 with Active Brake AB: Type E3 (Mounting from above / below with through-bolt)

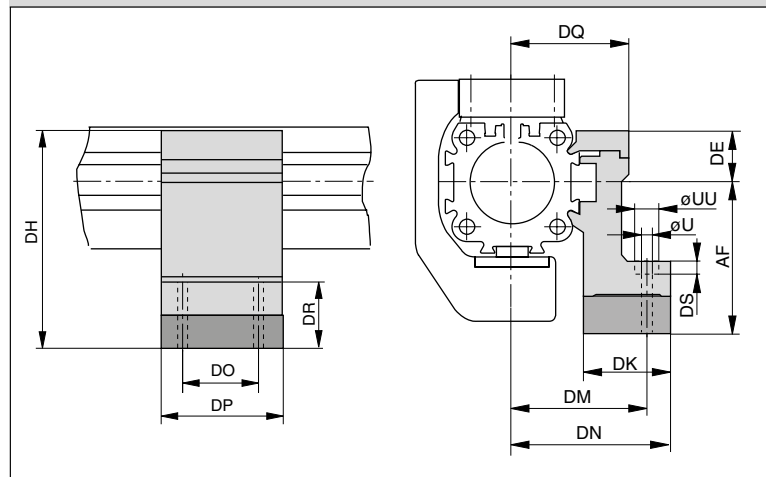

Dimension Table [mm]

Series	U	UU	AF	DE	DH	DK	DM	DN	DO	DP	DQ	DR	DS	Order no. Type E3
AB 25	5.5	10	49	16	65	26	40	47.5	36	50	34.5	35	5.7	20353FIL
AB 32	5.5	10	52	16	68	27	46	54.5	36	50	40.5	32	5.7	20356FIL
AB 40	7	–	60	23	83	34	53	60	45	60	45	32	–	20359FIL
AB 50	7	–	72	23	95	34	59	67	45	60	52	31	–	20362FIL
AB 63	9	–	93	34	127	44	73	83	45	65	63	48	–	20453FIL
AB 80	11	–	110	39.5	149.5	63	97	112	55	80	81	53	–	20819FIL

### Accessories for linear drives with Active Brakes – please order separately

Description	For details information, see:
Clevis mounting	Page 104
Adaptor profile	Page 118
T-groove profile	Page 119
Connection profile	Page 120
Magnetic switch (can <b>only</b> be mounted opposite of the brake housing)	Page 123-126
Incremental displacement measuring system SFI-plus	Page 129-133

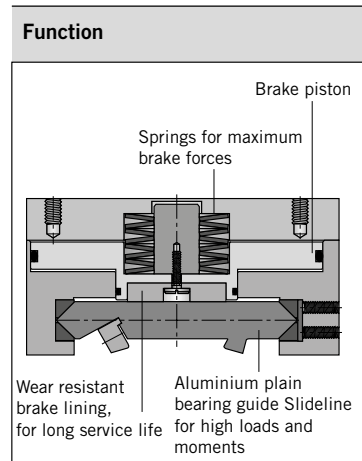
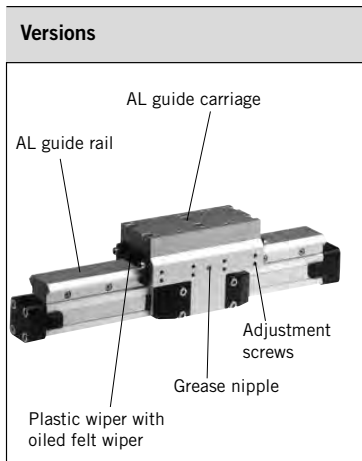

# Multi-Brake Passive Brake with plain bearing guide Slideline SL



Series MB-SL 25 to 80  
for Linear-drive  
• Series OSP-P

**Function:**

The Multi-Brake is a passive device. When the air pressure is removed the brake is actuated and movement of the cylinder is blocked. The brake is released by pressurisation.

The high friction, wear resistant brake linings allow the Multi-Brake to be used as a dynamic brake to stop cylinder movement in the shortest possible time. The powerful springs also allow the Multi-Brake to be used effectively in positioning applications.

**Features:**

- Brake operated by spring actuation
- Brake release by pressurisation
- Anodised aluminium rail, with prism shaped slide elements
- Adjustable plastic slide elements
- Composite sealing system with plastic and felt wiper elements to remove dirt and lubricate the slideway
- Replenishable guide lubrication by integrated grease nipples
- Blocking function in case of pressure loss
- Intermediate stops possible

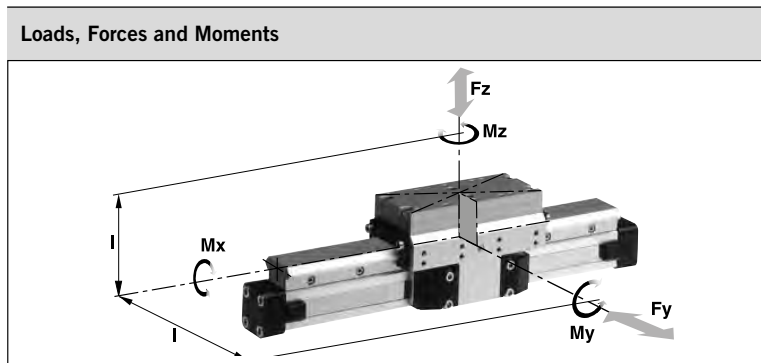

**Technical Data:**

The table shows the maximum values for light, shock-free operation, which must not be exceeded even in dynamic operation.

Load and moment data are based on speeds  $v < 0.2$  m/s.

Operating pressure 4.5 - 8 bar  
A pressure of 4.5 bar is required to release the brake.

For further technical information, please refer to the data sheets for linear drives OSP-P (see from page 15)

<sup>1)</sup> Braking surface dry – oil on the braking surface will reduce the braking force

<sup>2)</sup> **Please note:** in the cushioning diagram, the mass of the guide carriage has to be added to the total moving mass.

Series	For linear drive	Max. moments [Nm]			Max. loads [N] Fy, Fz	Max. brake force [N] <sup>1)</sup>	Mass of linear drive with guide [kg]		Mass <sup>2)</sup> guide carriage [kg]	Order-No. ** MB-SL Guide with passive brake without cylinder *
		Mx	My	Mz			with 0 mm stroke	increase per 100 mm stroke		
MB-SL 25	OSP-P25	14	34	34	675	470	2.04	0.39	1.10	20796
MB-SL 32	OSP-P32	29	60	60	925	790	3.82	0.65	1.79	20797
MB-SL 40	OSP-P40	50	110	110	1600	1200	5.16	0.78	2.34	20798
MB-SL 50	OSP-P50	77	180	180	2000	1870	8.29	0.97	3.63	20799
MB-SL 63	OSP-P63	120	260	260	2500	2900	13.31	1.47	4.97	20800
MB-SL 80	OSP-P80	120	260	260	2500	2900	17.36	1.81	4.97	20846

\*\* Please use this order pattern: Order-No. + „stroke in mm“ (5 digits)  
Example: MB-SL guide with passive brake D 25 mm, stroke 1000 mm: 20796-01000

**\*MB-SL in combination with cylinder see page. 51, pos. 20**  
For linear drives overview see page 9-13  
For mountings see page 107-115

The right to introduce technical modifications is reserved

Series OSP-P with Passive Brake MB-SL

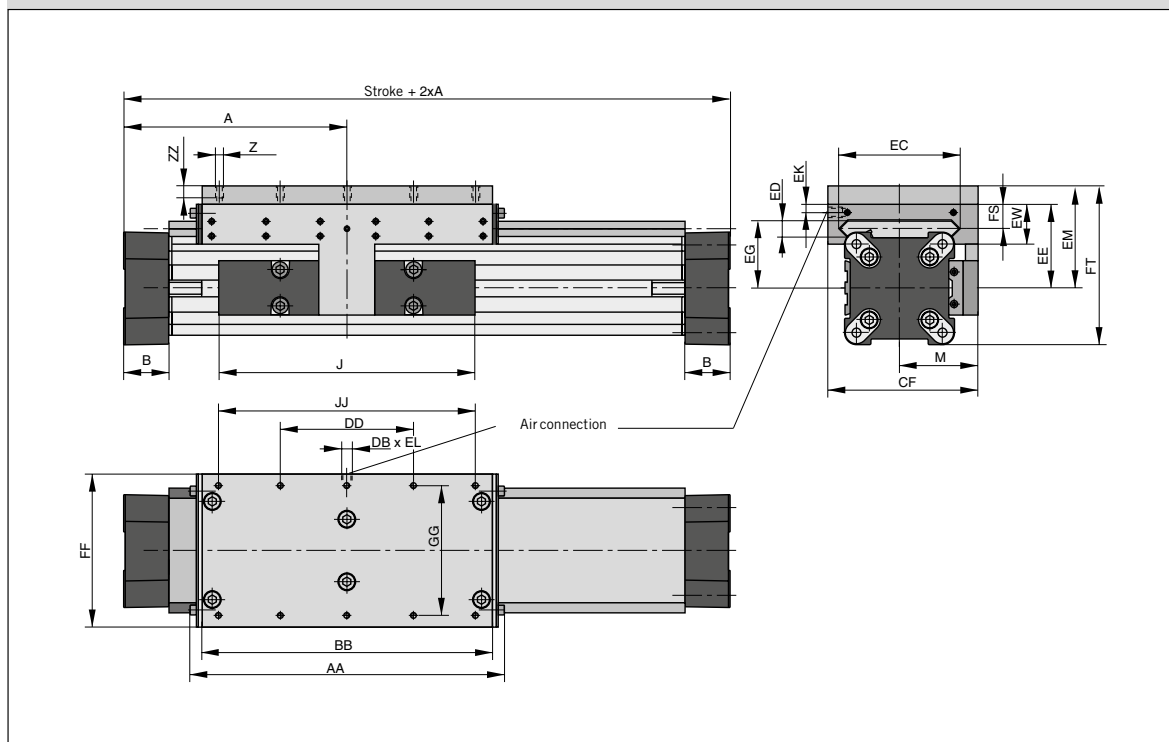

Dimension Table [mm]

Series	A	B	J	M	Z	AA	BB	DB	DD	CF	EC	ED	EE	EG	EK	EL	EM	EW	FF	FT	FS	GG	JJ	ZZ
MB-SL25	100	22	117	40,5	M6	162	142	M5	60	72.5	47	12	53	39	9	5	73	30	64	93.5	20	50	120	12
MB-SL32	125	25.5	152	49	M6	205	185	G1/8	80	91	67	14	62	48	7	10	82	33	84	108	21	64	160	12
MB-SL40	150	28	152	55	M6	240	220	G1/8	100	102	77	14	64	50	6.5	10	84	34	94	118.5	21.5	78	200	12
MB-SL50	175	33	200	62	M6	284	264	G1/8	120	117	94	14	75	56	10	12	95	39	110	138.5	26	90	240	12
MB-SL63	215	38	256	79	M8	312	292	G1/8	130	152	116	18	86	66	11	12	106	46	152	159	29	120	260	13
MB-SL80	260	47	348	96	M8	312	292	G1/8	130	169	116	18	99	79	11	12	119	46	152	185	29	120	260	13

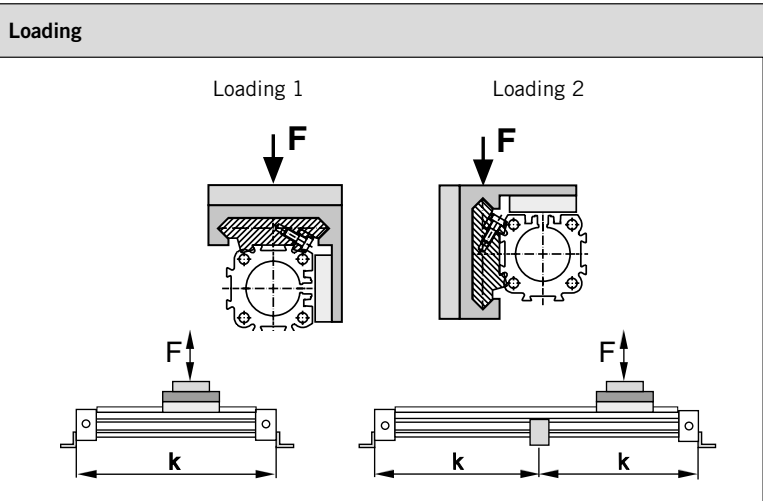

## Mid Section Support

(for versions see page 106, 109)

Mid section supports are required from a certain stroke length to prevent excessive deflection and vibration of the linear drive.

The diagrams show the maximum permissible unsupported length in relation to loading. A distinction must be drawn between loading 1 and loading 2. Deflection of 0.5 mm max. between supports is permissible.

**Note:**

For speeds  $v > 0.5$  m/s the distance between supports should not exceed 1 m.

**Permissible Unsupported Length MB-SL25, MB-SL32**

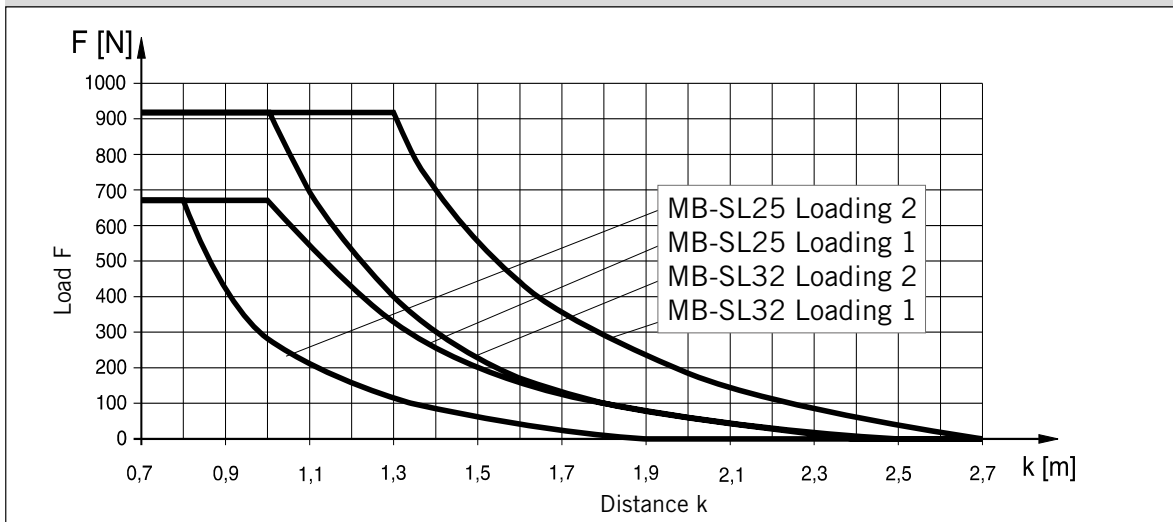

**Permissible Unsupported Length MB-SL40, MB-SL50, MB-SL63 and MB-SL80**

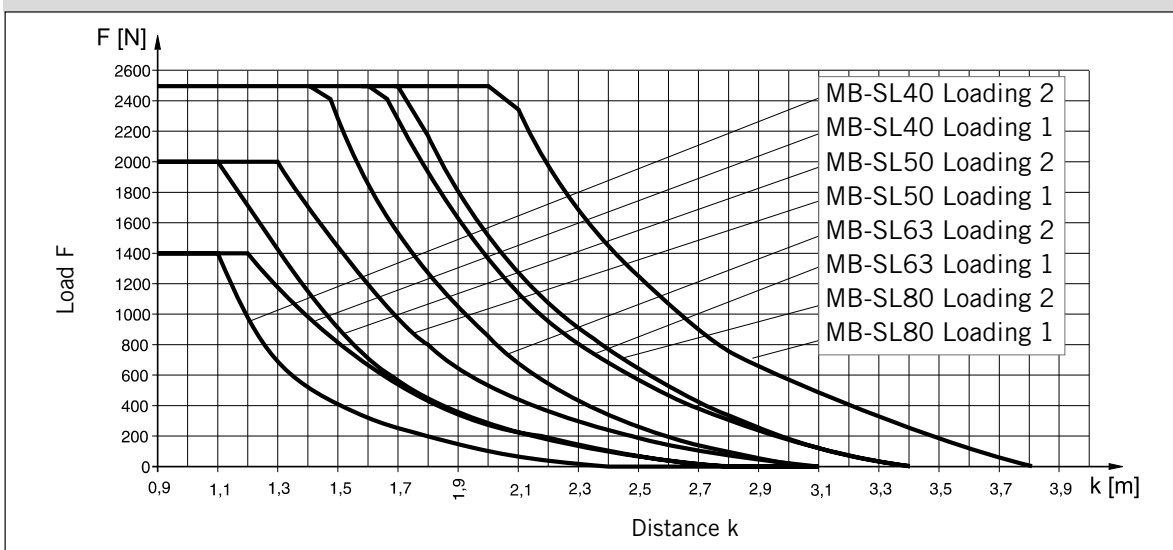

The right to introduce technical modifications is reserved

### Application Example - Vertical Application

Control of a cylinder with 3/2 way valves. Basic position – exhausted

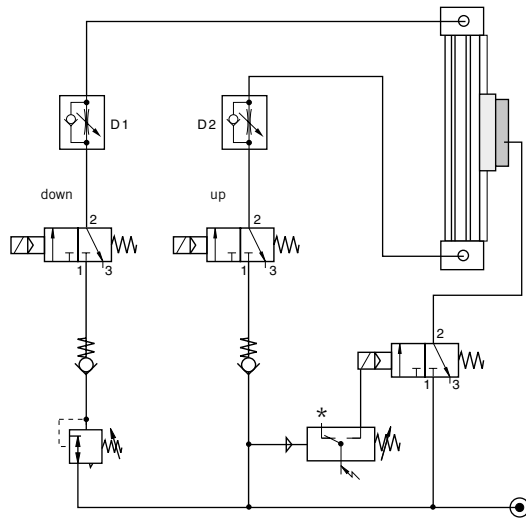

Control of a cylinder with 3/2 way valves. Basic position – pressurised

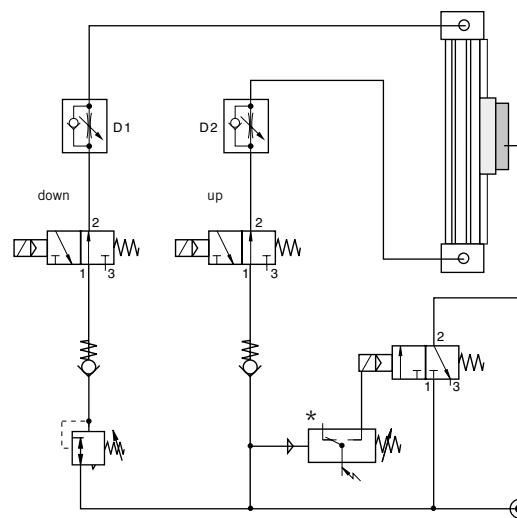

#### Control Examples

Under normal operating circumstances the pressure switch is closed and the air flows through the 3/2 way solenoid valves from port 1 to 2, thus lifting the brake from the rail (operating condition).

The brake is pressurised by means of a 3/2 way valve in combination with a pressure switch. When there is a pressure loss, the brake is actuated by the pressure switch.

When the air pressure is restored to both cylinder chambers, the brake is lifted and the linear drive can be moved again.

The speed regulating valves D1 and D2 control the speed of the linear drive, and have no influence on the brake. The two non-return valves give the system a higher stability. The pressure regulating valve is used to compensate for the downward force in this vertical application.

#### Please note:



**Before the brake is lifted, make sure that both air chambers of the linear drive are pressurised. Small diameter tubing, fittings and valves with a nominal diameter, and tubing that is too long all change the reaction time of the brake!**

#### \* Tip:

The pressure switch actuates the brake when the pressure drops below the set value.

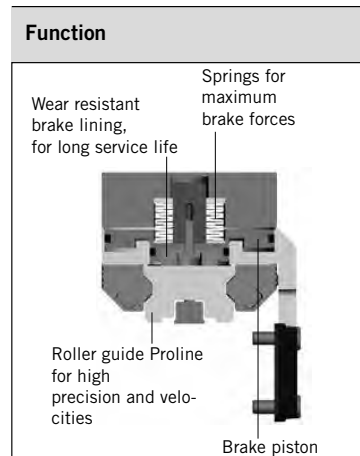
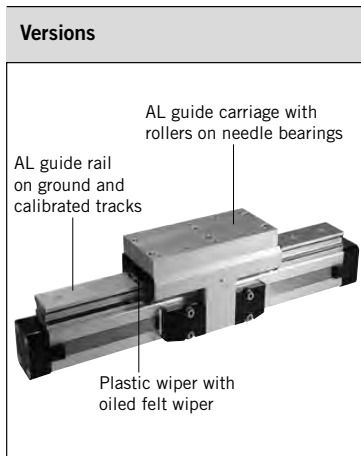

# Multi-Brake Passive Brake with Aluminium Roller Guide Proline PL



**Series MB-PL 25 to 50  
for Linear-drive  
• Series OSP-P**

**Function:**

The Multi-Brake is a passive device. When the air pressure is removed the brake is actuated and movement of the cylinder is blocked. The brake is released by pressurisation.

The high friction, wear resistant brake linings allow the Multi-Brake to be used as a dynamic brake to stop cylinder movement in the shortest possible time. The powerful springs also allow the Multi-Brake to be used effectively in positioning applications.

**Features:**

- Brake operated by spring actuation
- Brake release by pressurisation
- Composite sealing system with plastic and felt wiper elements to remove dirt and lubricate the slideway
- Blocking function in case of pressure loss
- Intermediate stops possible

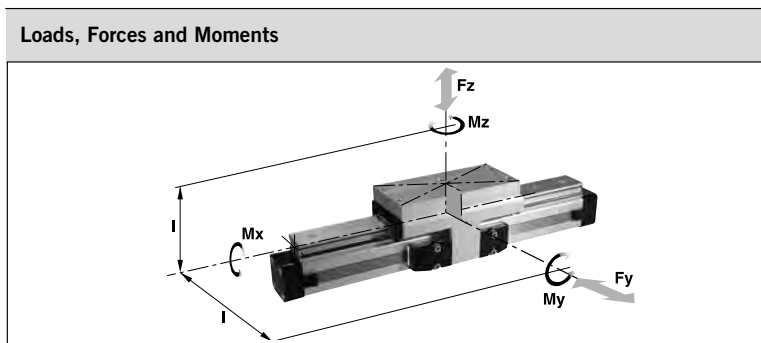

**Technical Data**

The table shows the maximal permissible loads. If multiple moments and forces act upon the cylinder simultaneously, the following equation applies:

$$\frac{M_x}{M_{x_{max}}} + \frac{M_y}{M_{y_{max}}} + \frac{M_z}{M_{z_{max}}} + \frac{F_y}{F_{y_{max}}} + \frac{F_z}{F_{z_{max}}} \leq 1$$

The sum of the loads should not exceed >1. With a load factor of less than 1, service life is 8000 km

The table shows the maximum permissible values for light, shock-free operation, which must not be exceeded even under dynamic conditions.

Operating Pressure 4.5 - 8 bar. A pressure of min. 4.5 bar release the brake.

<sup>1)</sup> Braking surface dry – oil on the braking surface will reduce the braking force

<sup>2)</sup> **Please note:** In the cushioning diagram, the mass of the guide carriage has to be added to the total moving mass.

Series	For linear drive	Max. moments [Nm]			Max. loads [N] F <sub>y</sub> , F <sub>z</sub>	Max. brake force [N] <sup>1)</sup>	Mass of linear drive with guide [kg]		Mass <sup>2)</sup> guide carriage [kg]	Order-No. ** <b>MB-PL</b> Guide with passivebrake without cylinder *
		M <sub>x</sub>	M <sub>y</sub>	M <sub>z</sub>			with 0 mm stroke	increase per 100 mm stroke		
<b>MB-PL25</b>	OSP-P25	16	39	39	857	315	2.14	0.40	1.24	<b>20864</b>
<b>MB-PL32</b>	OSP-P32	29	73	73	1171	490	4.08	0.62	2.02	<b>20865</b>
<b>MB-PL40</b>	OSP-P40	57	158	158	2074	715	5.46	0.70	2.82	<b>20866</b>
<b>MB-PL50</b>	OSP-P50	111	249	249	3111	1100	8.60	0.95	4.07	<b>20867</b>

\*\* Please use this order pattern: Order-No. + „stroke in mm“ (5 digits)  
Example: MB-PL guide with passive brake, D25 mm, stroke 1000 mm: 20864-01000

**\*MB-PL in combination with cylinder see page 61, pos. 20**  
For **linear drives** overview see page 9-13  
For **mountings** see page 107-115

The right to introduce technical modifications is reserved

**Series OSP-P with Passive Brake MB-PL**

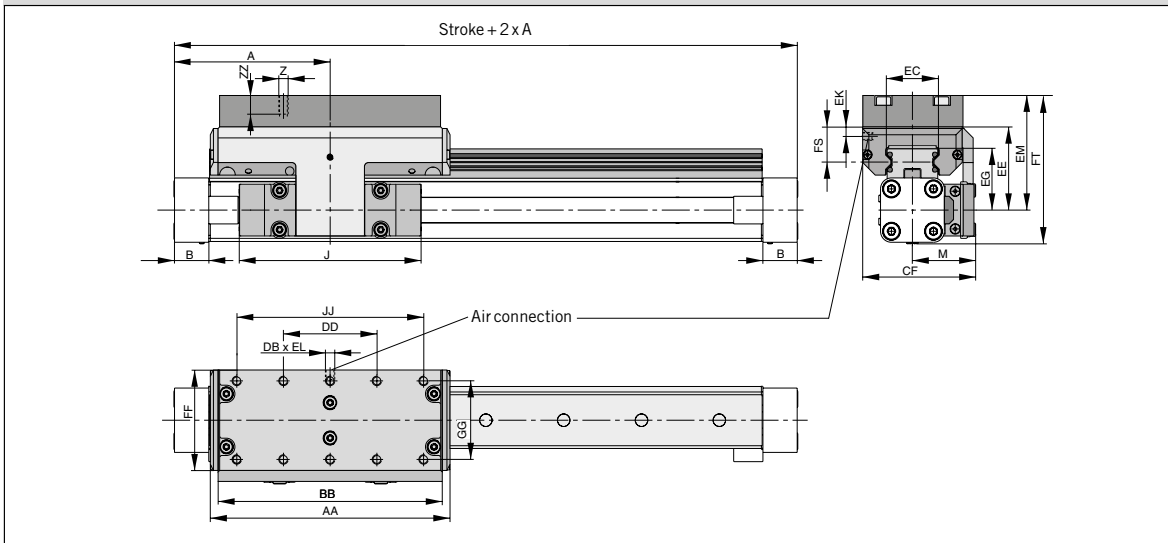

**Dimension Table [mm] Series OSP-P MB-PL25, MB-PL32, MB-PL40, MB-PL50**

Series	A	B	J	M	Z	AA	BB	DB	DD	CF	EC	EE	EG	EK	EL	EM	FF	FS	FT	GG	JJ	ZZ
MB-PL25	100	22	117	40.5	M6	154	144	M5	60	72.5	32.5	53	39	9	5	73	64	23	93.5	50	120	12
MB-PL32	125	25.5	152	49	M6	197	187	G1/8	80	91	42	62	48	7	10	82	84	25	108	64	160	12
MB-PL40	150	28	152	55	M6	232	222	G1/8	100	102	47	64	50.5	6.5	10	84	94	23.5	118.5	78	200	12
MB-PL50	175	33	200	62	M6	276	266	G1/8	120	117	63	75	57	10	12	95	110	29	138.5	90	240	16

## Mid Section Support

(For versions see page 106, 109)

Mid section supports are required from a certain stroke length to prevent excessive deflection and vibration of the linear drive. The diagrams show the maximum permissible unsupported length in relation to loading. A distinction must be drawn between loading 1 and loading 2. Deflection of 0.5 mm max. between supports is permissible.

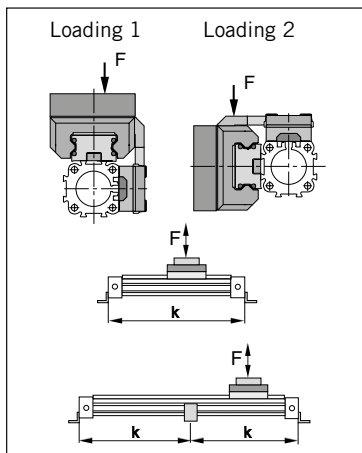

**Note:**

For speeds  $v > 0.5$  m/s the distance between supports should not exceed 1 m.

**Permissible Unsupported Length OSP-P MB-PL25, MB-PL32, MB-PL40, MB-PL50**

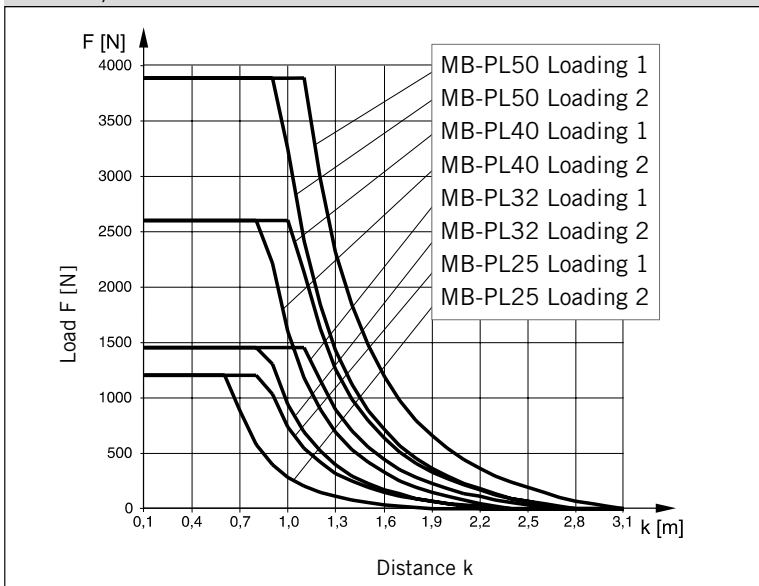

### Application Example - Vertical Application

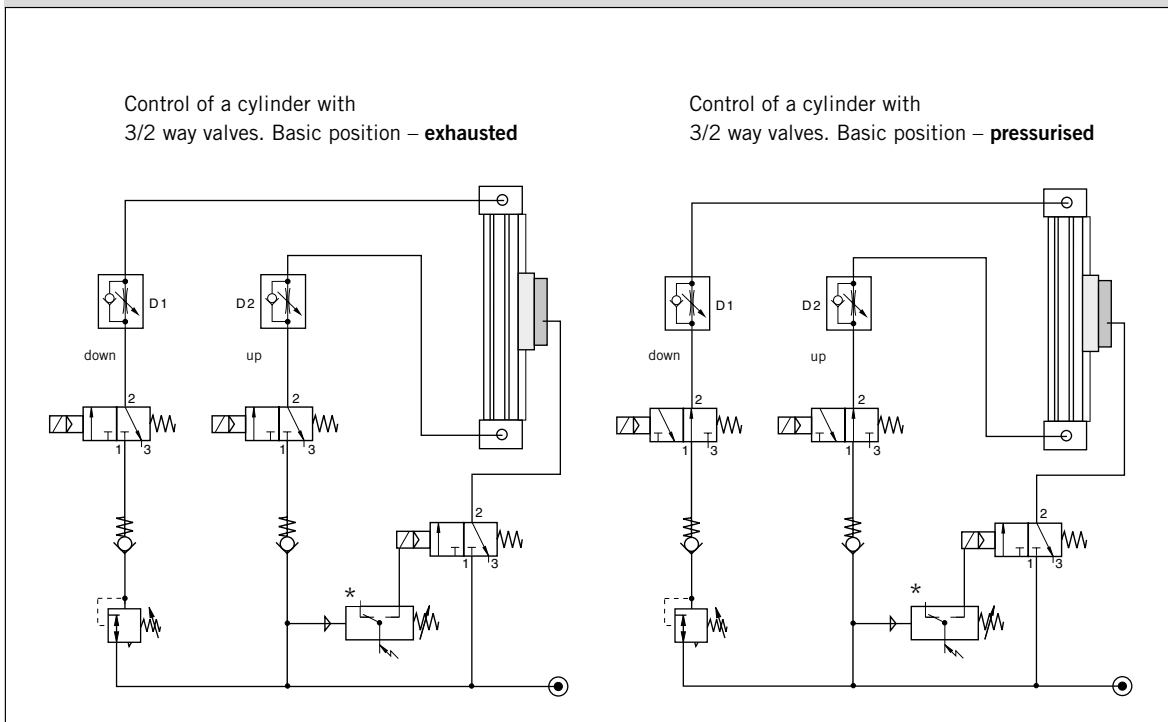

#### Control Examples

Under normal operating circumstances the pressure switch is closed and the air flows through the 3/2 way solenoid valves from port 1 to 2, thus lifting the brake from the rail (operating condition).

The brake is pressurised by means of a 3/2 way valve in combination with a pressure switch. When there is a pressure loss, the brake is actuated by the pressure switch.

When the air pressure is restored to both cylinder chambers, the brake is lifted and the linear drive can be moved again.

The speed regulating valves D1 and D2 control the speed of the linear drive, and have no influence on the brake. The two non-return valves give the system a higher stability. The pressure regulating valve is used to compensate for the downward force in this vertical application.



#### Please note:

**Before the brake is lifted, make sure that both air chambers of the linear drive are pressurised. Small diameter tubing, fittings and valves with a nominal diameter, and tubing that is too long all change the reaction time of the brake!**

#### \* Tip:

The pressure switch actuates the brake when the pressure drops below the set value.















# Linear Drive-Accessories (Mountings and Magnetic Switches) Series OSP-P



## Contents

Description	Page
Overview	102
Clevis Mounting	103-104
End Cap Mountings	105
End Cap Mountings (for Linear Drives with guides)	107, 108, 110, 112, 113
Mid-Section Support	106
Mid-Section Support (for Linear Drives with guides)	107, 109, 111, 114, 115
Inversion Mounting	117
Adaptor Profile	118
T-Slot Profile	119
Connection Profile	120
Duplex Connection	121
Multiplex Connection	122
Magnetic Switch for T-Nut mounting P8S-G	123-126
Magnetic Switch ATEX-version 	on request
Cable Cover	127

The right to introduce technical modifications is reserved

Linear Drive Accessories for Series OSP-P		
Description		
Clevis Mounting		Page 103-104
End Cap Mountings		Page 105
End Cap Mountings (for Linear Drives with guides)		From page 107
Mid-Section Support		Page 106
Mid-Section Support (for Linear Drives with guides)		From page 107
Inversion Mounting		Page 117
Adaptor Profile		Page 118
T-Slot Profile		Page 119
Connection Profile		Page 120
Dulex Connection		Page 121
Multiplex Connection		Page 122
Magnetic Switch for T-Nut mounting P8S-G		Page 123-126
Magnetic Switch, ATEX-version 		on request
Cable cover		Page 127

Series OSP-P10

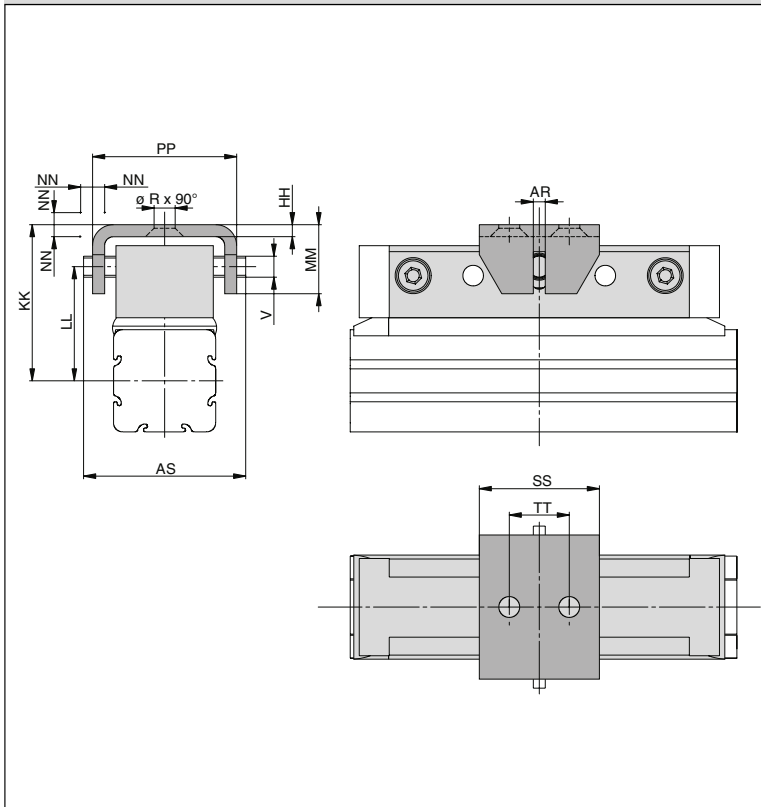

# Linear Drive Accessories

## ø 10 mm Clevis Mounting



For Linear-drive  
• Series OSP-P

When external guides are used, parallelism deviations can lead to mechanical strain on the piston. This can be avoided by the use of a clevis mounting. In the drive direction, the mounting has very little play. Freedom of movement is provided as follows:

- Tilting in direction of movement
- Vertical compensation
- Tilting sideways
- Horizontal compensation

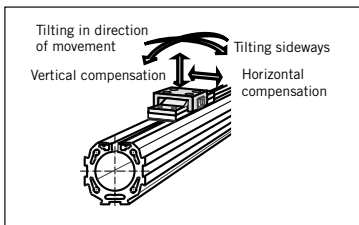

Dimension Table [mm]

Order instructions in combination with basic cylinder see page 24, pos. 19

For series	øR	V	AR	AS	HH	KK	LL	MM	NN*	PP	SS	TT	Order No.	
													Standard	Stainless
OSP-P10	3.4	3.5	2	27	2	26	19	11.5	1	24	20	10	20971FIL	-

\* Dimension NN gives the possible plus and minus play in horizontal and vertical movement, which also makes tilting sideways possible.



For rodless pneumatic cylinder OSP-P overview see page 9-13

The right to introduce technical modifications is reserved

# Linear Drive Accessories

## ø 16-80 mm

### Clevis Mounting



For Linear-drive  
• Series OSP-P

When external guides are used, parallelism deviations can lead to mechanical strain on the piston. This can be avoided by the use of a clevis mounting. In the drive direction, the mounting has very little play. Freedom of movement is provided as follows:

- Tilting in direction of movement
- Vertical compensation
- Tilting sideways
- Horizontal compensation

A stainless steel version is also available.



Series OSP-P16 to 50

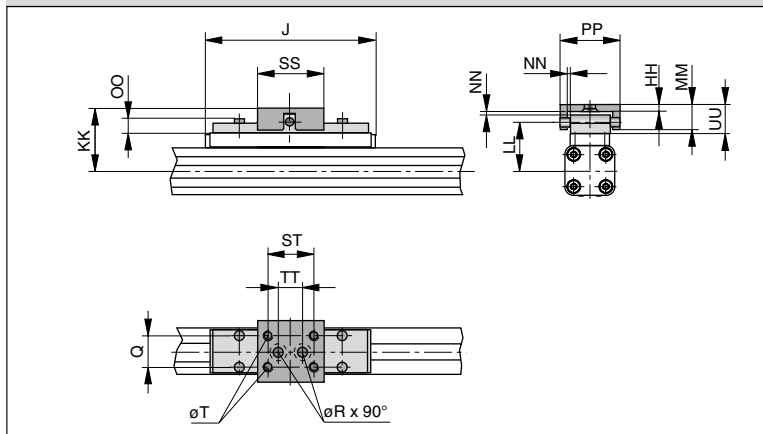

Series OSP-P63 and 80

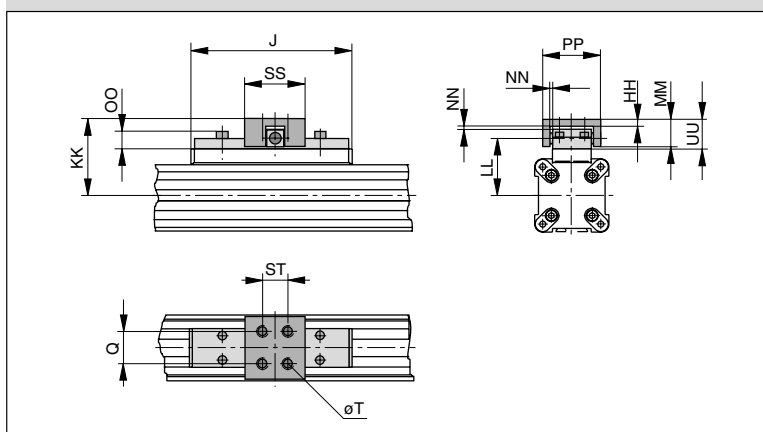

**Please note:**  
When using additional inversion mountings, take into account the dimensions on page 117.

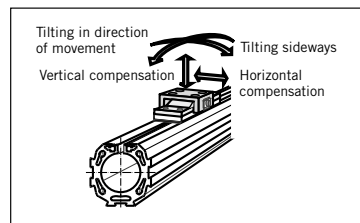

Dimension Table [mm]

Order instructions in combination with basic cylinder see page 24, pos. 19

For series	J	Q	T	øR	HH	KK	LL	MM	NN*	OO	PP	SS	ST	TT	UU	Order No.	
																Standard	Stainless
OSP-P16	69	10	M4	4.5	3	34	26.6	10	1	8.5	26	28	20	10	11	20462FIL	20463FIL
OSP-P25	117	16	M5	5.5	3.5	52	39	19	2	9	38	40	30	16	21	20005FIL	20092FIL
OSP-P32	152	25	M6	6.6	6	68	50	28	2	13	62	60	46	40	30	20096FIL	20094FIL
OSP-P40	152	25	M6	-	6	74	56	28	2	13	62	60	46	-	30	20024FIL	20093FIL
OSP-P50	200	25	M6	-	6	79	61	28	2	13	62	60	46	-	30	20097FIL	20095FIL
OSP-P63	256	37	M8	-	8	100	76	34	3	17	80	80	65	-	37	20466FIL	20467FIL
OSP-P80	348	38	M10	-	8	122	96	42	3	16	88	90	70	-	42	20477FIL	20478FIL

\* Dimension NN gives the possible plus and minus play in horizontal and vertical movement, which also makes tilting sideways possible.

For rodless pneumatic cylinder OSP-P overview see page 9-13

Series OSP-P10 : Type A1

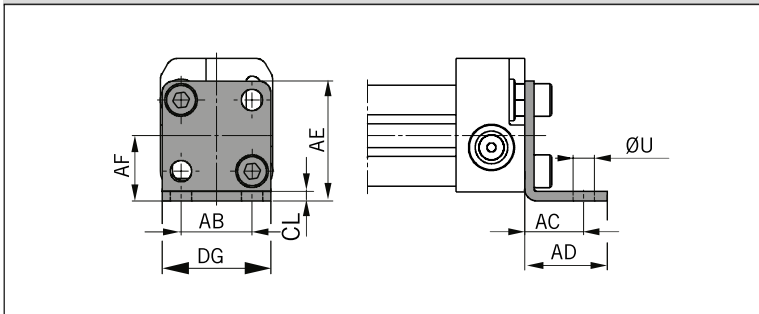

# Linear Drive Accessories

∅ 10-80 mm  
End Cap Mountings



For Linear-drive  
• Series OSP-P

On the end-face of each end cap there are four threaded holes for mounting the actuator.

The hole layout is square, so that the mounting can be fitted to the bottom, top or either side, regardless of the position chosen for the air connection.

Material:  
Series OSP-P10 – P32:  
Galvanised steel.  
Series OSP-P40 – P80:  
Anodized aluminium.

The mountings are supplied in pairs.

Series OSP-P16 to 32: Type A1

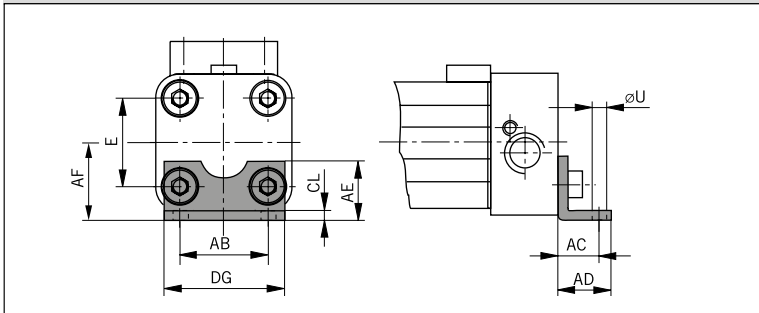

Series OSP-P40 to 80: Type C1

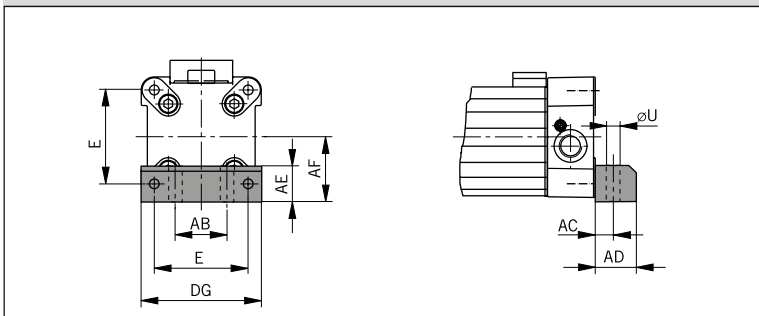

Dimension Table [mm]

For series	E	∅U	AB	AC	AD	AE	AF	CL	DG	Order-No. (pair)	
										Type A1	Type C1
OSP-P10	-	3.6	12	10	14	20.2	11	1.6	18.4	0240FIL	-
OSP-P16	18	3.6	18	10	14	12.5	15	1.6	26	20408FIL	-
OSP-P25	27	5.8	27	16	22	18	22	2.5	39	2010FIL	-
OSP-P32	36	6.6	36	18	26	20	30	3	50	3010FIL	-
OSP-P40	54	9	30	12.5	24	24	38	-	68	-	4010FIL
OSP-P50	70	9	40	12.5	24	30	48	-	86	-	5010FIL
OSP-P63	78	11	48	15	30	40	57	-	104	-	6010FIL
OSP-P80	96	14	60	17.5	35	50	72	-	130	-	8010FIL

For rodless pneumatic cylinder OSP-P overview see page 9-13

The right to introduce technical modifications is reserved

# Linear Drive Accessories

## ∅ 10-80 mm

### Mid-Section Support



For Linear-drive  
• Series OSP-P

Note on Types E1 and D1  
(P16 – P80):

The mid-section support can also be mounted on the underside of the actuator, in which case its distance from the centre of the actuator is different.

For design notes, see page 17.

Stainless steel version on request.



**Series OSP-10, Type E1**  
(Mounting from above / below using a cap screw)

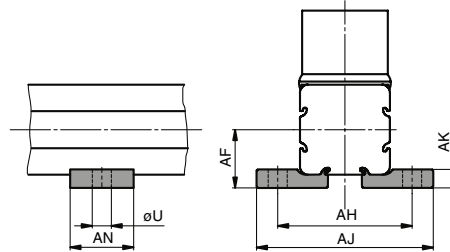

**Series OSP-P16 to P80: Type E1**  
(Mounting from above / below using a cap screw)

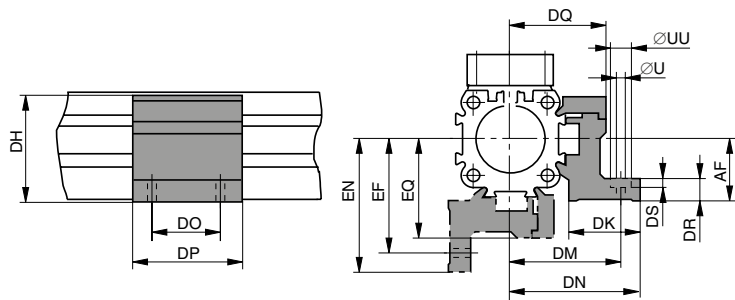

**Series OSP-16 to 80, Type D1**  
(Mounting from below with 2 screws)

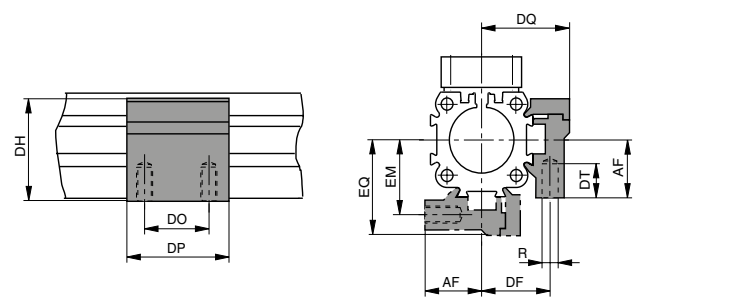

**Dimension Table [mm] Series OSP-P10**

For series	U	AF	AH	AJ	AK	AN	Order No.	
							Type E1	Type D1
OSP-P10	3.6	11	25.4	33.4	3.5	12	0250FIL	-

**Dimension Table [mm] – Series OSP-P16 to P80**

For series	R	∅U	∅UU	AF	DF	DH	DK	DM	DN	DO	DP	DQ	DR	DS	DT	EF	EM	EN	EQ	Order No.	
																				Type E1	Type D1
OSP-P16	M3	3.4	6	15	20	29.2	24	32	36.4	18	30	27	6	3.4	6.5	32	20	36.4	27	20435FIL	20434FIL
OSP-P25	M5	5.5	10	22	27	38	26	40	47.5	36	50	34.5	8	5.7	10	41.5	28.5	49	36	20009FIL	20008FIL
OSP-P32	M5	5.5	10	30	33	46	27	46	54.5	36	50	40.5	10	5.7	10	48.5	35.5	57	43	20158FIL	20157FIL
OSP-P40	M6	7	-	38	35	61	34	53	60	45	60	45	10	-	11	56	38	63	48	20028FIL	20027FIL
OSP-P50	M6	7	-	48	40	71	34	59	67	45	60	52	10	-	11	64	45	72	57	20163FIL	20162FIL
OSP-P63	M8	9	-	57	47.5	91	44	73	83	45	65	63	12	-	16	79	53.5	89	69	20452FIL	20451FIL
OSP-P80	M10	11	-	72	60	111.5	63	97	112	55	80	81	15	-	25	103	66	118	87	20482FIL	20480FIL

For rodless pneumatic cylinder OSP-P overview see page 9-13

# Linear Drive Accessories

## Mountings for Linear Drives fitted with OSP-Guides



For Linear-drives  
• Series OSP-P

Overview		Type – OSP Guides																
Mounting Type	Type	SLIDELINE PROLINE MULTIBRAKE								POWERSLIDE								
		16 <sup>1)</sup>	25	32	40	50	63 <sup>1)</sup>	80 <sup>1)</sup>	16/25	25/25	25/35	25/44	32/35	32/44	40/44	40/60	50/60	50/76
 End cap mounting	Type A1	X							X									
	Type A2	O	O	O														
	Type A3									O	O		O					
 End cap mounting, reinforced	Type B1		X	X					X	X	X	X	X					
	Type B3								O									
	Type B4											O		O				
	Type B5																	
 End cap mounting	Type C1			X	X	X	X								X	X	X	X
	Type C2			O	O													
	Type C3					O	O								O		O	
	Type C4															O		O
 Mid section support, wide Mid section support, small	Type D1	X	X	X	X	X	X	X	X	X	X	X	X	X	X	X	X	X
	Type E1	X	X	X	X	X	X	X	X	X	X	X	X	X	X	X	X	X
	Type E2	O	O	O	O	O												
	Type E3					O	O	O	O	O		O	O	O	O			
	Type E4											O	O	O	O			
Type E5																		

- X = carriage mounted in top (12 o'clock position)
- O = carriage mounted in lateral (3 or 9 o'clock position)
- = available components
- <sup>1)</sup> = not available for all sizes



**Note:**  
For mountings and mid-section supports for linear drives with recirculating ball bearing guide STARLINE, for recirculating ball bearing guide KF, see page 110 to 115.

For rodless pneumatic cylinder OSP-P see from page 9

The right to introduce technical modifications is reserved

## End cap mountings\*

Four internal screw threads are located in the end faces of all OSP actuators for mounting the drive unit. End cap mountings may be secured across any two adjacent screws.

### Material:

Series OSP-16, 25, 32:  
Galvanised steel

Series OSP-40,50, 63, 80:  
Anodized aluminium

The mountings are supplied in pairs.

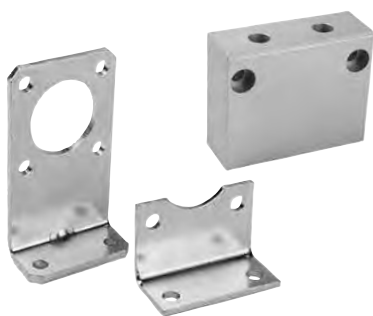

### Series OSP-P16, 25, 32: Type A

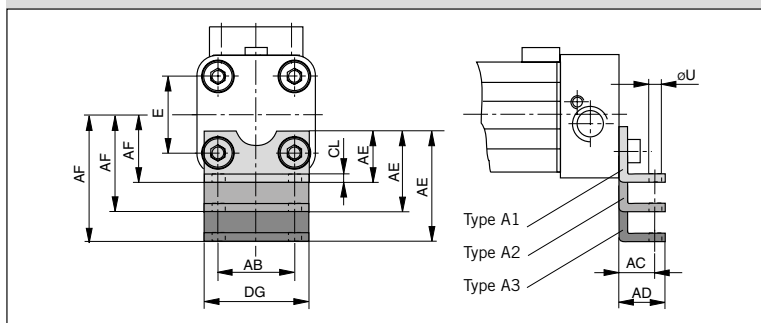

### Series OSP-P16, 25, 32: Type B

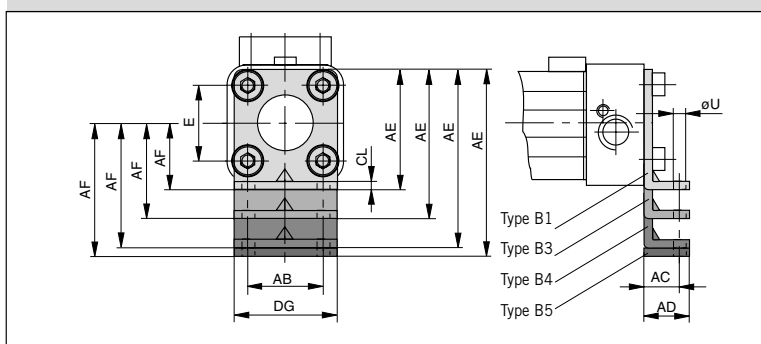

**Dimension Table [mm]**  
– Dimensions AE and AF (Dependant on the mounting type)

Mount. type	Dimensions AE for size							AF for size						
	16	25	32	40	50	63	80	16	25	32	40	50	63	80
A1	12.5	18	20	-	-	-	-	15	22	30	-	-	-	-
A2	27.5	33	34	-	-	-	-	30	37	44	-	-	-	-
A3	-	45	42	-	-	-	-	49	52	-	-	-	-	-
B1	-	42	55	-	-	-	-	22	30	-	-	-	-	-
B3	55	-	-	-	-	-	-	42	-	-	-	-	-	-
B4	-	80	85	-	-	-	-	60	60	-	-	-	-	-
B5	-	-	90	-	-	-	-	-	65	-	-	-	-	-
C1	-	-	-	24	30	40	50	-	-	-	38	48	57	72
C2	-	-	-	37	39	-	-	-	-	-	51	57	-	-
C3	-	-	-	46	54	76	88	-	-	-	60	72	93	110
C4	-	-	-	56	77	-	-	-	-	-	70	95	-	-

### Series OSP-P40, 50, 63, 80: Type C

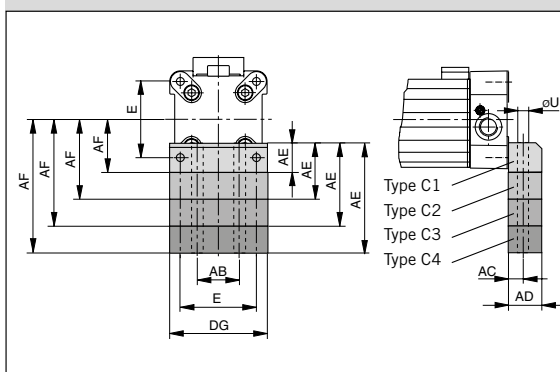

**Dimension Table [mm]**

For series	E	øU	AB	AC	AD	CL	DG
OSP-P16	18	3.6	18	10	14	1.6	26
OSP-P25	27	5.8	27	16	22	2.5	39
OSP-P32	36	6.6	36	18	26	3	50
OSP-P40	54	9	30	12.5	24	-	68
OSP-P50	70	9	40	12.5	24	-	86
OSP-P63	78	11	48	15	30	-	104
OSP-P80	96	14	60	17.5	35	-	130

\* see mounting instructions on page 107



# Linear Drive Accessories

## Ø 25-50 mm

### End Cap Mounting correspond to FESTO dimensions HP25 – 50

for Linear Drives with Recirculating Ball Bearing Guide

- Series OSP-P KF

On the end-face of each end cap there are four threaded holes for mounting the actuator.

**Material:**

Series OSP-P KF25 – 50:  
Anodized aluminium.

The mountings are supplied in pairs.

Series OSP-P KF25 to KF50: Type HP (Correspond to FESTO dimensions)

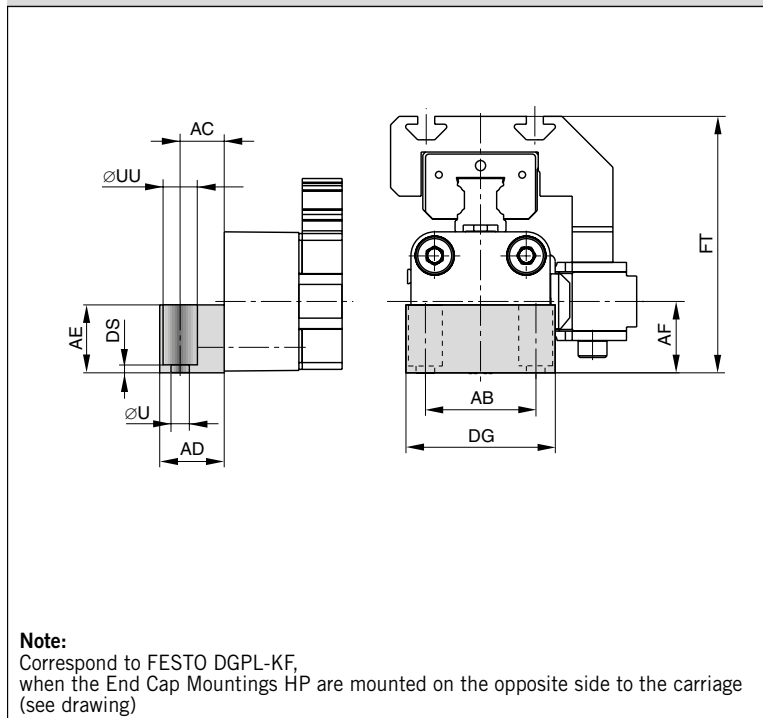

Dimension Table [mm]

Series	ØU	AB	AC	AD	AE	AF	DG	DS	FT	ØUU	Order No.
HP25	5.5	32.5	13	19	20	21	44	2	75.5	10	21107FIL
HP32	6.6	38	17	24	24	27	52	3	87.5	11	21108FIL
HP40	6.6	45	17.5	24	24	35	68	2	104.5	11	21109FIL
HP50	9	65	25	35	35	48	86	6	138.5	15	21110FIL

**Series OSP-P KF25: Type MUP**  
(Mounting over through holes)

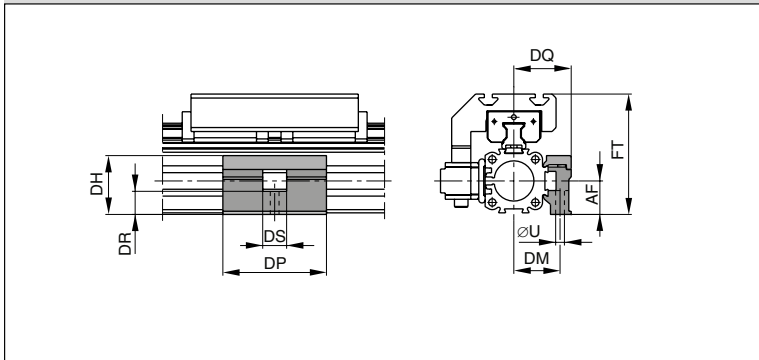

**Series OSP-P KF32 to KF40: Type MUP**  
(Mounting over through holes)

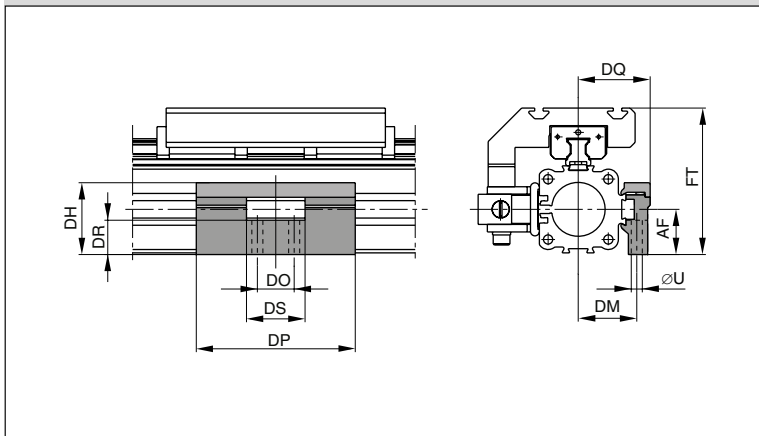

**Series OSP-P KF50: Type MUP**  
(Mounting over through holes)

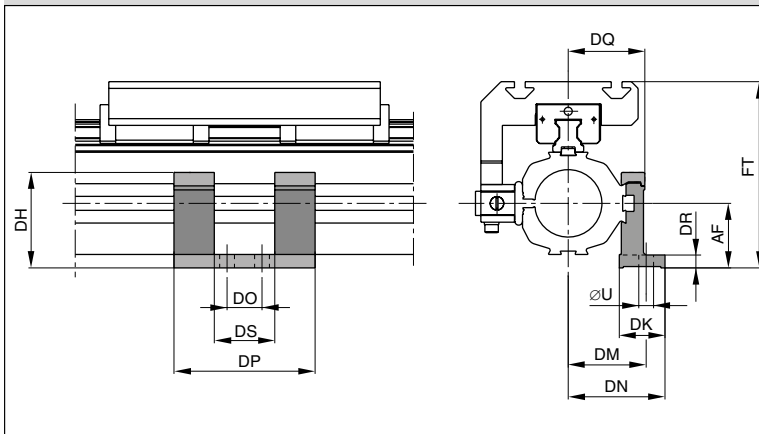

# Linear Drive Accessories

## Ø 25-50 mm

### Mid-Section Support correspond to FESTO dimensions MUP25 – 50

for Linear Drives with Recirculating Ball Bearing Guide

- Series OSP-P KF

For design notes, see page 73

**Note:**  
Correspond to FESTO DGPL-KF, when the Mid-Section Support MUP are mounted on the 90° side to the carriage (see drawings).

**Dimension Table [mm]**

Series	ØU	AF	DH	DK	DM	DN	DO	DP	DQ	DR	DS	FT	Order No.
MUP25	5.5	21	36.9	–	29	–	–	65	36	14.5	15	75.5	21119FIL
MUP32	6.6	27	42.9	–	35	–	22	95	43	20.5	35	87.5	21120FIL
MUP40	6.6	35	58	–	40	–	22	95	48	28.5	35	104.5	21121FIL
MUP50	11	48	71	34	58	72	26	105	57	10	45	138.5	21122FIL

The right to introduce technical modifications is reserved

# Linear Drive Accessories

## Ø 16 to 32 mm

### End Cap Mounting

#### Type: B

for Linear Drives with Recirculating Ball Bearing Guide

- Series OSP-P STL
- Series OSP-P KF

**Material:**  
Galvanised steel  
Anodized aluminium

The mountings are supplied in pairs.

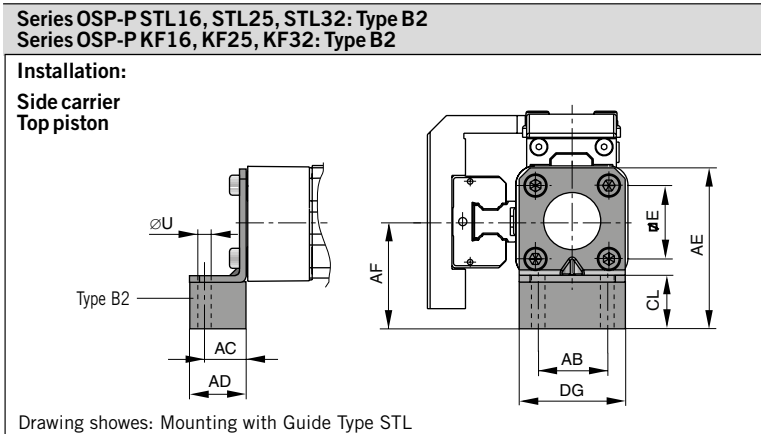
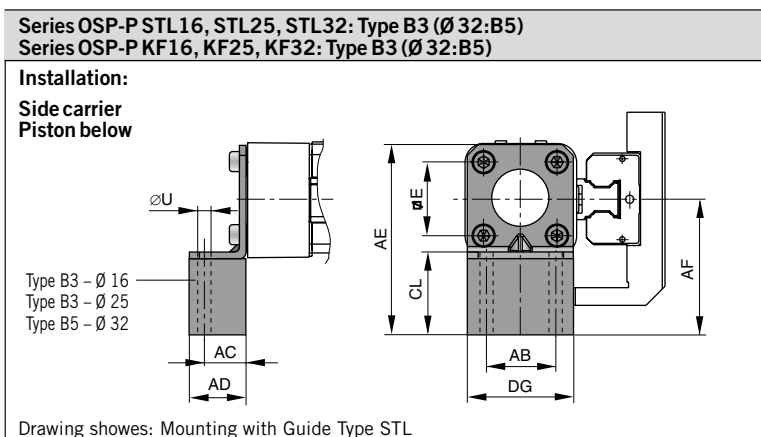
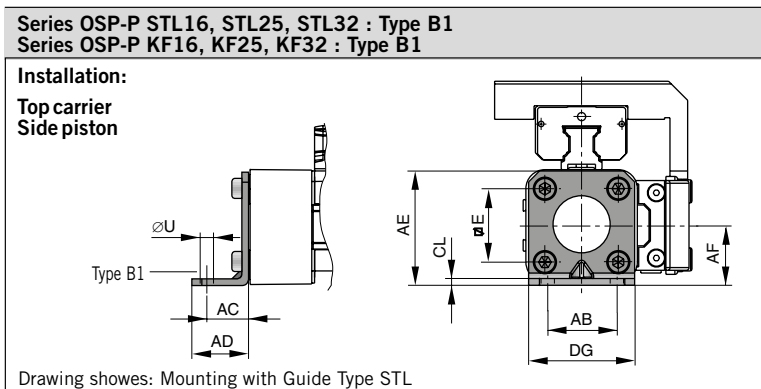

**Dimension Table [mm] for End Cap Mounting Type: B1 to B5**

For series	Mounting	E	ØU	AB	AC	AD	AE	AF	CL	DG	Order No. (pair)
OSP-PSTL16 OSP-PKF16	B1	18	3.6	18	10	14	28	15	2	26	21135FIL
	B2	18	3.6	18	10	14	43	30	17	26	21136FIL
	B3	18	3.6	18	10	14	55	42	29	26	21137FIL
OSP-P STL25 OSP-P KF25	B1	27	5.8	27	16	22	42	22	2.5	39	20311FIL
	B2	27	5.8	27	16	22	57	37	17.5	39	21138FIL
	B3	27	5.8	27	16	22	69	49	29.5	39	21139FIL
OSP-P STL32 OSP-P KF32	B1	36	6.6	36	18	26	55	30	3	50	20313FIL
	B2	36	6.6	36	18	26	69	44	17	50	21140FIL
	B5	36	6.6	36	18	26	90	65	9	50	21141FIL

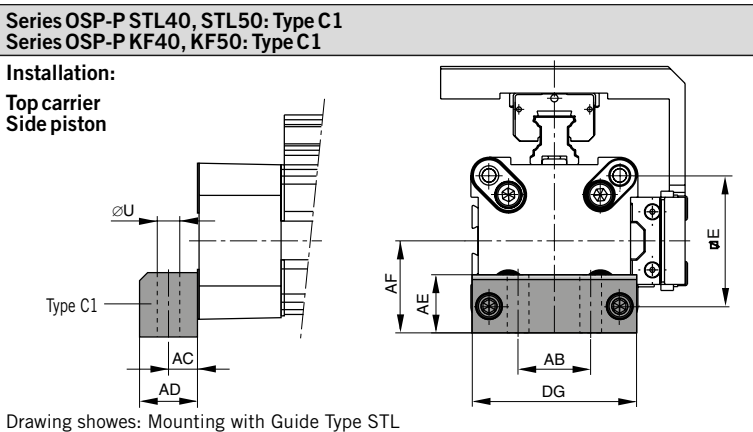

## Ø 40 to 50 mm End Cap Mounting Type: C

for Linear Drives with Recirculating  
 Ball Bearing Guide

- Series OSP-P STL
- Series OSP-P KF

**Material:**  
 Anodized aluminium

The mountings are supplied in pairs.

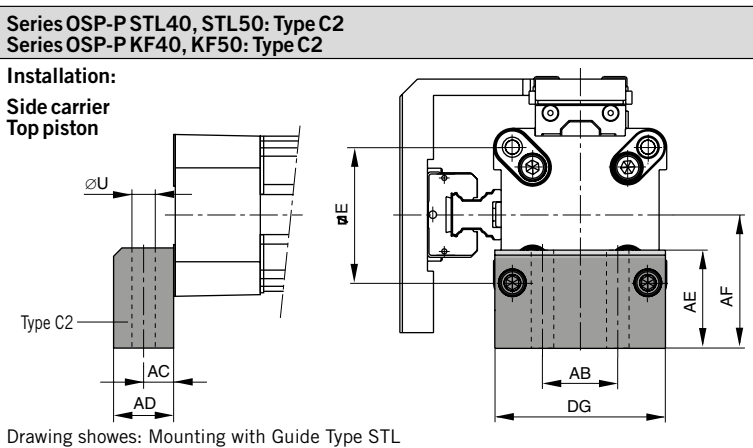
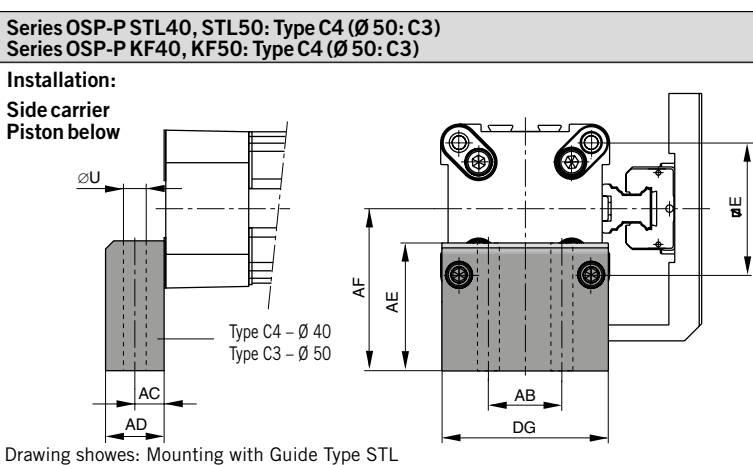

**Dimension Table [mm] for End Cap Mounting Type: C1 to C4**

For series	Mounting	E	ØU	AB	AC	AD	AE	AF	DG	Order No. (pair)
OSP-P STL40 OSP-P KF40	C1	54	9	30	12.5	24	24	38	68	4010FIL
	C2	54	9	30	12.5	24	37	51	68	20338FIL
	C4	54	9	30	12.5	24	56	70	68	20340FIL
OSP-P STL50 OSP-P KF50	C1	70	9	40	12.5	24	30	48	86	5010FIL
	C2	70	9	40	12.5	24	39	57	86	20349FIL
	C3	70	9	40	12.5	24	54	72	86	20350FIL



The right to introduce technical modifications is reserved

# Linear Drive Accessories

## Ø 16 to 50

### Mid-Section Support

#### Type: D1ST

for Linear Drives with Recirculating Ball Bearing Guide

- Series OSP-P STL
- Series OSP-P KF

Note on Types D1ST  
The mid-section support can also be mounted on the underside of the actuator, in which case its distance from the centre of the actuator is different.

For design notes, see  
page 65 (Serie OSP-P STL)  
page 73 (Serie OSP-P KF)



Series OSP-P STL16 to STL50: Type D1ST  
Series OSP-P KF16 to KF50: Type D1ST

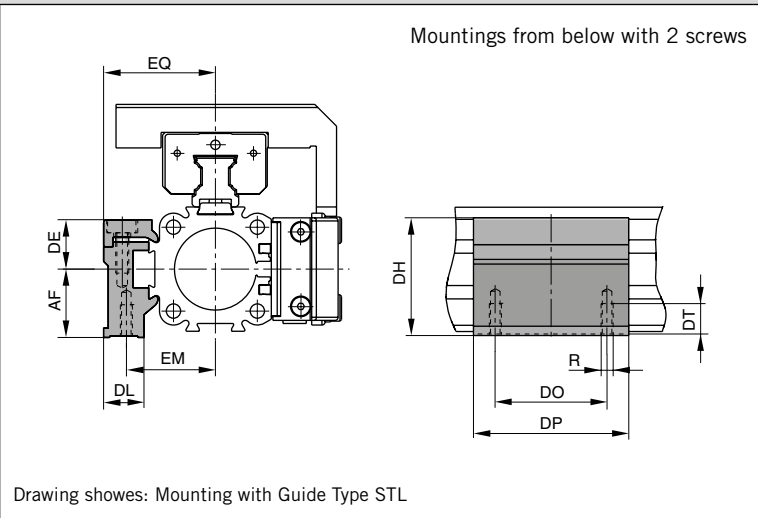

Dimension Table [mm] Mid-Section Support D1ST

For series OSP-P ..	Mounting Type	R	AF	DE	DH	DL	DO	DP	DT	EM	EQ	Order No.
STL/KF16	D1ST	M3	15	14.2	29.2	14.6	18	30	6.5	20	27	21125FIL
STL/KF25	D1ST	M5	22	16	38	13	36	50	10	28.5	36	21126FIL
STL/KF32	D1ST	M5	30	16	46	13	36	60	10	35.5	43	21127FIL
STL/KF40	D1ST	M6	38	23	61	19	45	60	11	38	48	21128FIL
STL/KF50	D1ST	M6	48	23	71	19	45	60	11	45	57	21129FIL

Order example: Type D1ST16      Order No. 21125FIL

# Mid-Section Support

## Type: E1ST bis E5ST

for Linear Drives with Recirculating Ball Bearing Guide

- Series OSP-P STL
- Series OSP-P KF



Series OSP-P STL16 to STL50: Type E1ST  
Series OSP-P KF16 to KF50: Type E1ST

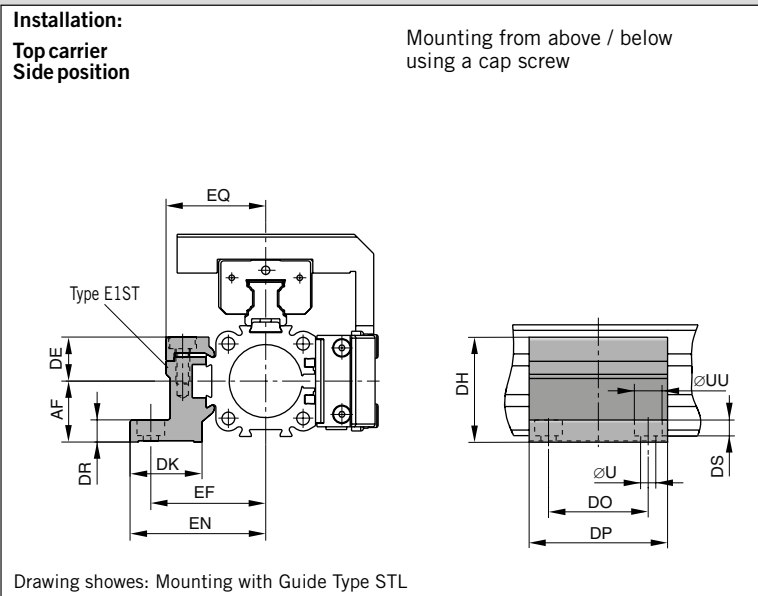

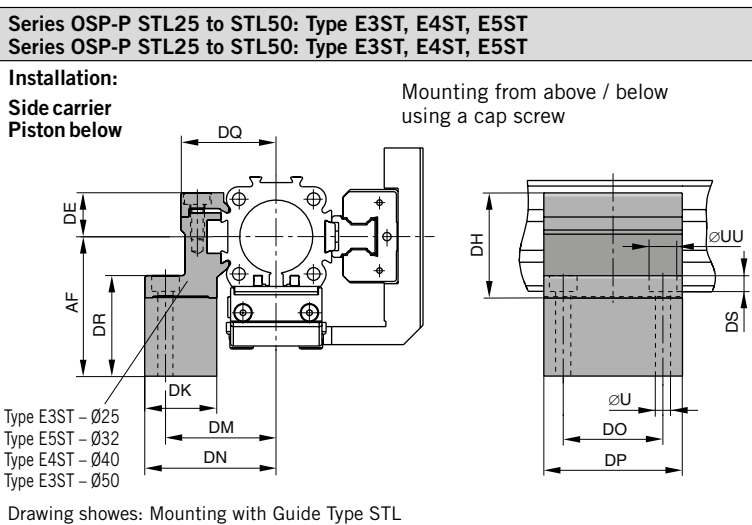

## Mid-Section Support Type: E1ST to E5ST

for Linear Drives with  
Recirculating Ball Bearing Guide

- Series OSP-P STL
- Series OSP-P KF

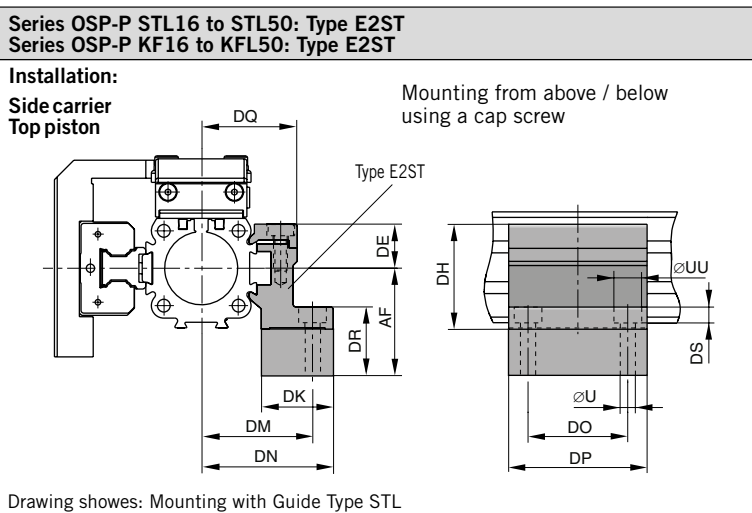

Dimension Table [mm] for Mid-Section Support E1ST to E5ST																		
For Series OSP-P..	Mounting Type	ØU	ØUU	AF	DE	DH	DK	DM	DN	DO	DP	DQ	DR	DS	EF	EN	EQ	Ident.-Nr.
STL/KF16	E1ST	3.4	6	15	14.2	29.2	24	32	36.4	18	30	27	6	3.4	32	36.4	27	21130FIL
STL/KF16	E2ST	3.4	6	30	14.2	29.2	24	32	36.4	18	30	27	21	3.4	32	36.4	27	21142FIL
STL/KF25	E1ST	5.5	10	22	16	38	26	40	47.5	36	50	34.5	8	5.7	41.5	49	36	21131FIL
STL/KF25	E2ST	5.5	10	37	16	38	26	40	47.5	36	50	34.5	23	5.7	41.5	49	36	21143FIL
STL/KF25	E3ST	5.5	10	49	16	38	26	40	47.5	36	50	34.5	35	5.7	41.5	49	36	21148FIL
STL/KF32	E1ST	5.5	10	30	16	46	27	46	54.5	36	60	40.5	10	5.7	48.5	57	43	21132FIL
STL/KF32	E2ST	5.5	10	44	16	46	27	46	54.5	36	60	40.5	24	5.7	48.5	57	43	21144FIL
STL/KF32	E5ST	5.5	10	65	16	46	27	46	54.5	36	60	40.5	45	5.7	48.5	57	43	21151FIL
STL/KF40	E1ST	7	-	38	23	61	34	53	60	45	60	45	10	-	56	63	48	21133FIL
STL/KF40	E2ST	7	-	51	23	61	34	53	60	45	60	45	23	-	56	63	48	21145FIL
STL/KF40	E4ST	7	-	70	23	61	34	53	60	45	60	45	42	-	56	63	48	21150FIL
STL/KF50	E1ST	7	-	48	23	71	34	59	67	45	60	52	10	-	64	72	57	21134FIL
STL/KF50	E2ST	7	-	57	23	71	34	59	67	45	60	52	19	-	64	72	57	21146FIL
STL/KF50	E3ST	7	-	72	23	71	34	59	67	45	60	52	34	-	64	72	57	21149FIL

Order example: Typ E1ST16

Order No. 21130FIL



Series OSP-P16 to 32

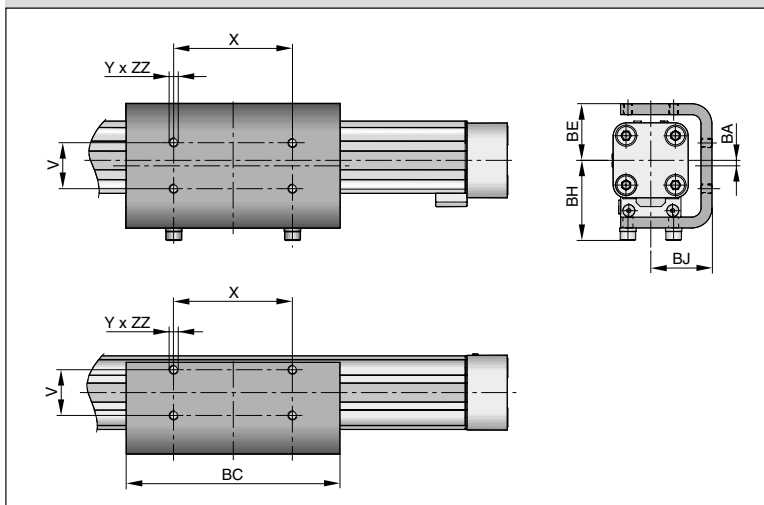

Series OSP-P40 to 80

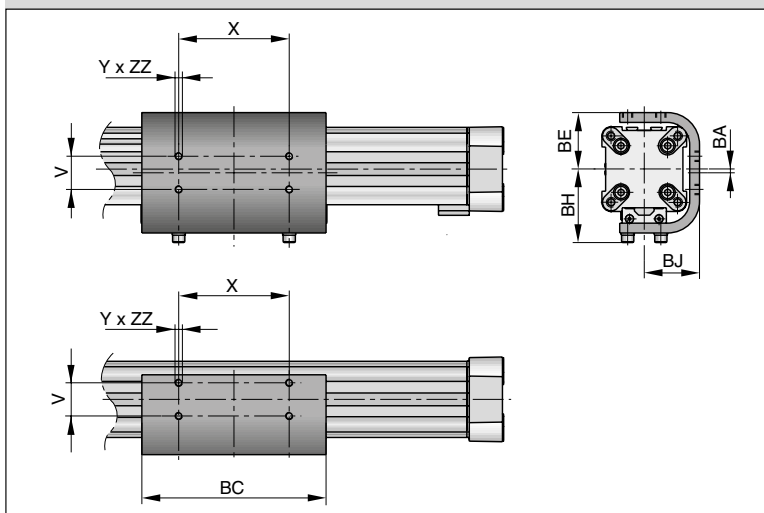

Dimension Table [mm]

For series	V	X	Y	BA	BC	BE	BH	BJ	ZZ	Order No.
OSP-P16	16,5	36	M4	2	69	23	33	25	4	20446FIL
OSP-P25	25	65	M5	3	117	31	44	33,5	6	20037FIL
OSP-P32	27	90	M6	3	150	38	52	39,5	6	20161FIL
OSP-P40	27	90	M6	3	150	46	60	45	8	20039FIL
OSP-P50	27	110	M6	1	200	55	65	52	8	20166FIL
OSP-P63	34	140	M8	2,5	255	68	83,5	64	10	20459FIL
OSP-P80	36	190	M10	3,5	347	88	107,5	82	15	20490FIL

**Note:**  
Order instructions in combination with basic cylinder see page 24, pos. 20

For rodless pneumatic cylinder OSP-P overview see page 9-13

# Linear Drive Accessories

## ø 16-80 mm

### Inversion Mounting



For Linear-drive  
• Series OSP-P

In dirty environments, or where there are special space problems, inversion of the cylinder is recommended. The inversion bracket transfers the driving force to the opposite side of the cylinder. The size and position of the mounting holes are the same as on the standard cylinder.

Stainless steel version on demand.

**Please note:**  
Other components of the OSP system such as **mid-section supports**, **magnetic switches** and the **external air passage for the P16**, can still be mounted on the free side of the cylinder.

**Note:**  
When combining single end porting with inversion mountings, RS magnetic switches can only be mounted directly opposite to the external air-supply profile.

**Important Note:**  
May be used in combination with Clevis Mounting, ref. dimensions on page 104.



The right to introduce technical modifications is reserved

# Linear Drive Accessories

## ∅ 16-50 mm Adaptor Profile



For Linear-drive  
• Series OSP-P

### Adaptor Profile OSP

- A universal attachment for mounting of valves etc.
- Solid material



### Series OSP-P16 to 50

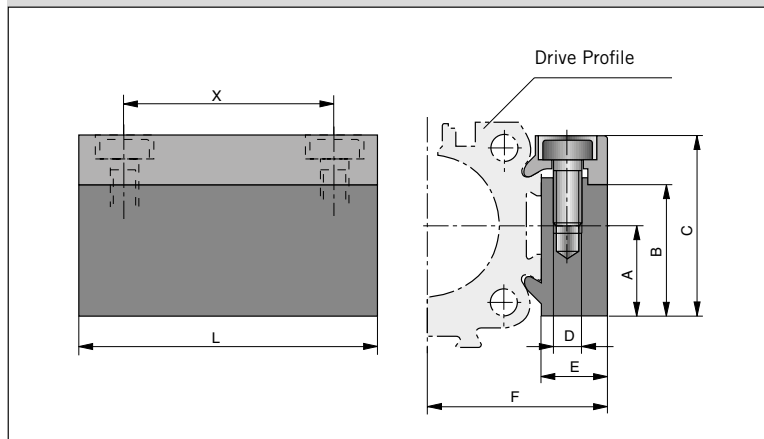

### Dimension Table [mm]

For series	A	B	C	D	E	F	L	X	Order No.	
									Standard	Stainless
OSP-P16	14	20.5	28	M3	12	27	50	38	20432FIL	20438FIL
OSP-P25	16	23	32	M5	10.5	30.5	50	36	20006FIL	20186FIL
OSP-P32	16	23	32	M5	10.5	36.5	50	36	20006FIL	20186FIL
OSP-P40	20	33	43	M6	14	45	80	65	20025FIL	20267FIL
OSP-P50	20	33	43	M6	14	52	80	65	20025FIL	20267FIL

### Series OSP-P63 to 80

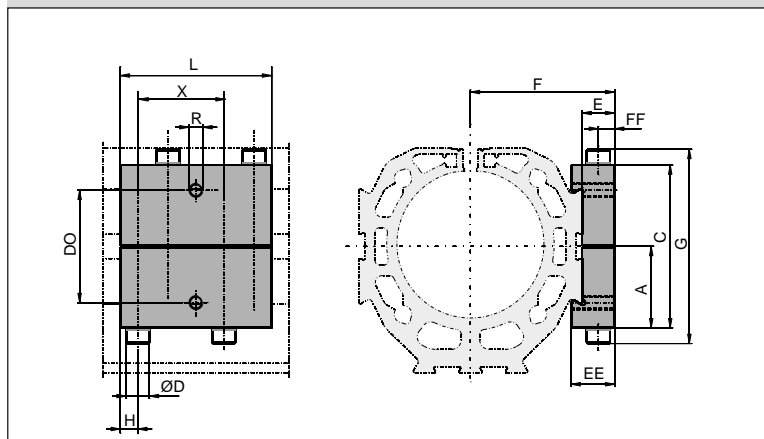

### Dimensions [mm]

Series	A	C	∅D	E	F	G	H	L	R	X	DO	EE	FF	Order-No.*
OSP-P63	34.8	70	10	14	62	83	7.5	65	M6	37	48	18.7	7	20792FIL
OSP-P80	34.8	70	10	14	75	83	7.5	65	M6	37	48	18.7	7	20792FIL

\* Stainless version

For rodless pneumatic cylinder OSP-P overview see page 9-13

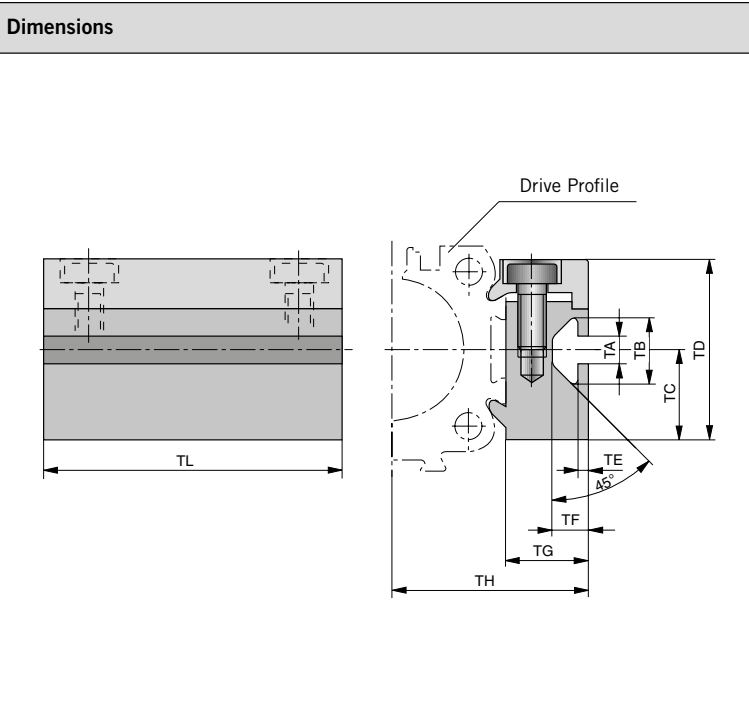

# Linear Drive Accessories

## ∅ 16-50 mm

### T-Slot Profile



For Linear-drive  
• Series OSP-P

#### T-Slot Profile OSP

• A universal attachment for mounting with standard T-Nuts

Dimension Table [mm]											
For series	TA	TB	TC	TD	TE	TF	TG	TH	TL	Order No.	
										Standard	Stainless
OSP-P16	5	11.5	14	28	1.8	6.4	12	27	50	20433FIL	20439FIL
OSP-P25	5	11.5	16	32	1.8	6.4	14.5	34.5	50	20007FIL	20187FIL
OSP-P32	5	11.5	16	32	1.8	6.4	14.5	40.5	50	20007FIL	20187FIL
OSP-P40	8.2	20	20	43	4.5	12.3	20	51	80	20026FIL	20268FIL
OSP-P50	8.2	20	20	43	4.5	12.3	20	58	80	20026FIL	20268FIL

Following T-nuts from the company ITEM could be used:

Cyl.-Series	T-nut St 5	T-nut St 8
OSP-P16-32	●	
OSP-P40-50		●



For rodless pneumatic cylinder OSP-P overview see page 9-13

The right to introduce technical modifications is reserved

# Linear Drive Accessories

## ø 16-50 mm Connection Profile



- For combining
- Series OSP-P with system profiles
  - Series OSP-P with Series OSP-P

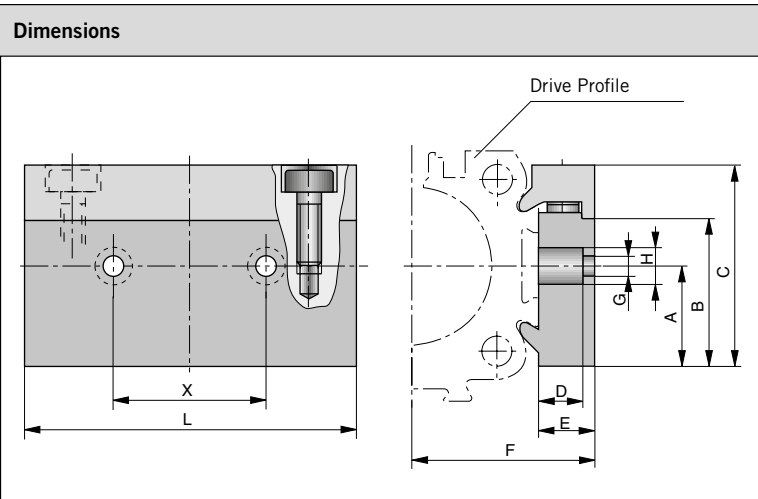

**Dimension Table [mm]**

For series	for mounting on the carrier of	A	B	C	D	E	F	G	H	L	X	Order No.
OSP-P16	OSP25	14	20.5	28	8.5	12	27	5.5	10	50	25	20849FIL
OSP-P25	OSP32-50	16	23	32	8.5	10.5	30.5	6.6	11	60	27	20850FIL
OSP-P32	OSP32-50	16	23	32	8.5	10.5	36.5	6.6	11	60	27	20850FIL
OSP-P40	OSP32-50	20	33	43	8	14	45	6.6	11	60	27	20851FIL
OSP-P50	OSP32-50	20	33	43	8	14	52	6.6	11	60	27	20851FIL

**Possible Combinations**

**Combination of Series OSP-P with system profiles**

**Combination of Series OSP-P with Series OSP-P**



For rodless pneumatic cylinder OSP-P overview see page 9-13

### Dimensions

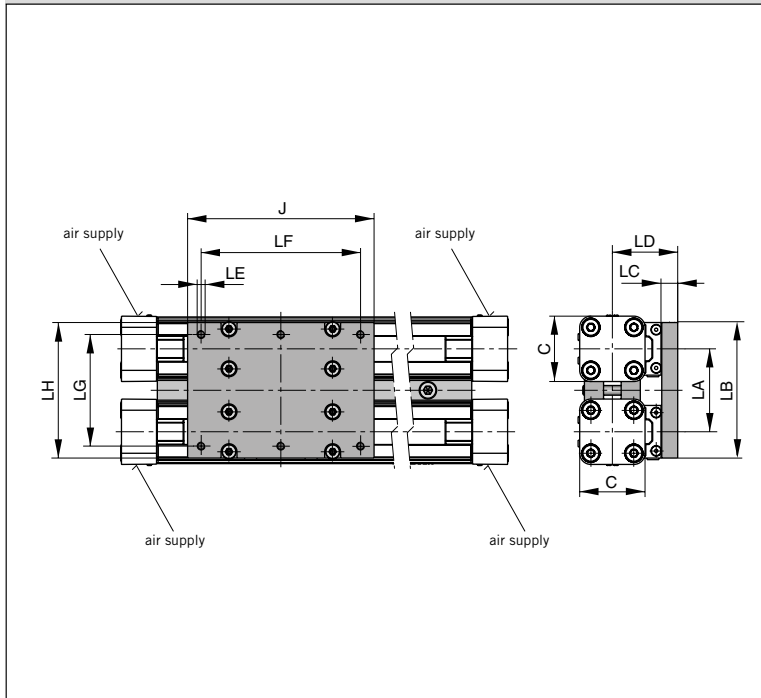

## Linear Drive Accessories

### ∅ 25-50 mm

### Duplex Connection



For connection of cylinders of the Series OSP-P

The duplex connection combines two OSP-P cylinders of the same size into a compact unit with high performance.

### Dimension Table [mm]

For series	C	J	LA	LB	LC	LD	LE	LF	LG	LH	Order No.	
											Standard	Stainless
OSP-P25	41	117	52	86	10	41	M5	100	70	85	20153FIL	20194FIL
OSP-P32	52	152	64	101	12	50	M6	130	80	100	20290FIL	20291FIL
OSP-P40	69	152	74	111	12	56	M6	130	90	110	20156FIL	20276FIL
OSP-P50	87	200	88	125	12	61	M6	180	100	124	20292FIL	20293FIL

### Features

- increased load and torque capacity
- higher driving forces

### Included in delivery:

- 2 clamping profiles with screws
- 1 mounting plate with fixings

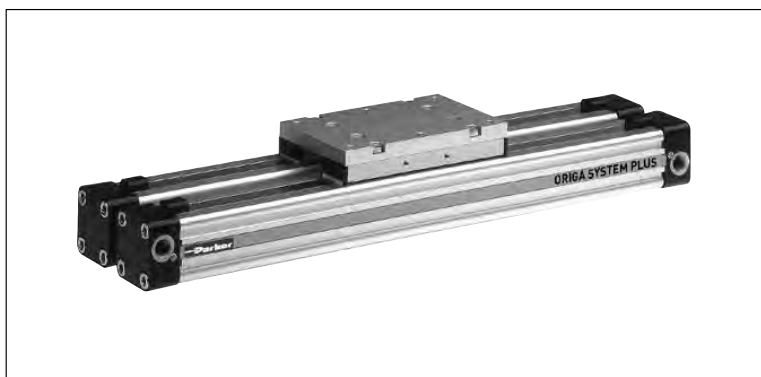

**Note:**  
Order instructions in combination with basic cylinder see page 24, pos. 20



For rodless cylinders OSP-P overview see page 9-13

The right to introduce technical modifications is reserved

# Linear Drive Accessories

## ø 25-50 mm

### Multiplex Connection



For connection of cylinders of the Series OSP-P

The multiplex connection combines two or more OSP-P cylinders of the same size into on unit.

#### Features

- The orientation of the carriers can be freely selected

#### Included in delivery:

- 2 clamping profiles with clamping screws

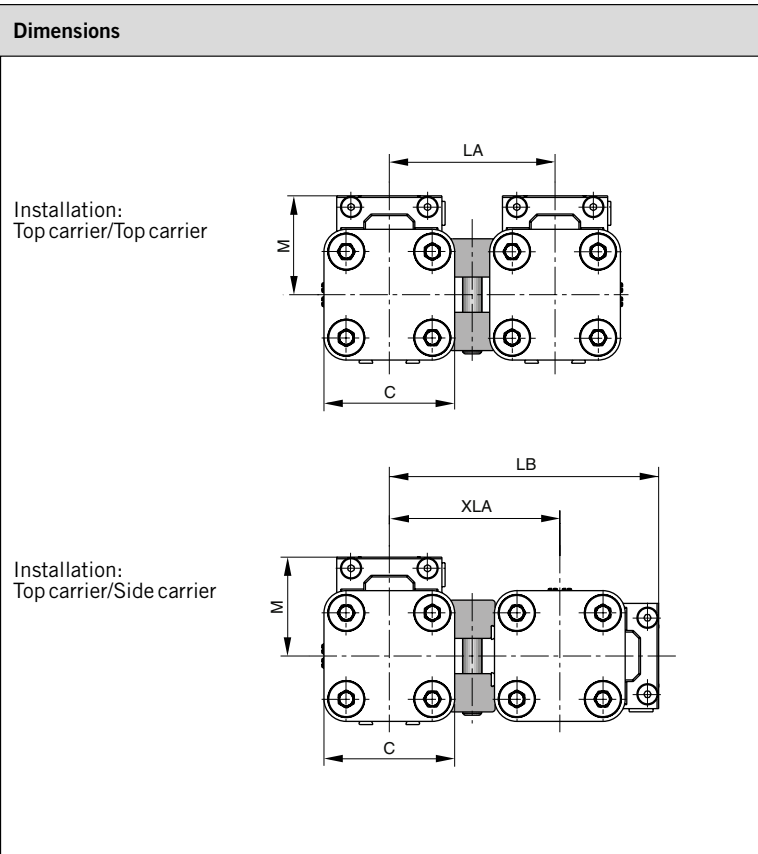

**Dimension Table [mm]**

For series	C	M	LA	LB	XLA	Order No.	
						Standard	Stainless
OSP-P25	41	31	52	84.5	53.5	20035FIL	20193FIL
OSP-P32	52	38	64	104.5	66.5	20167FIL	20265FIL
OSP-P40	69	44	74	121.5	77.5	20036FIL	20275FIL
OSP-P50	87	49	88	142.5	93.5	20168FIL	20283FIL

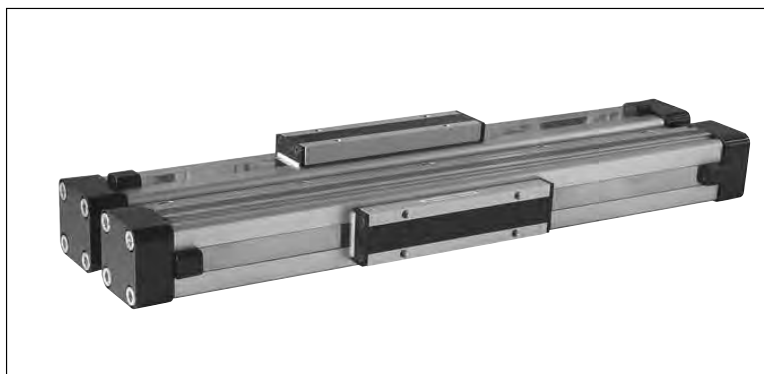

For rodless cylinders OSP-P overview see page 9-13

Characteristics		Series P8S-GR P8S-GE	Series P8S-GP
Characteristics	Unit	Description	
<b>Electrical Characteristics</b>			
Switching output / -function		Reed / NO Reed / NC	PNP / NO
Electrical configuration		2-wire	3-wire
Display LED yellow		yes (not Reed NC)	
Operating voltage Ub	V	10 - 30 AC/DC	10 - 30 DC
Voltage drop	V	≤ 3.5 (NO) ≤ 0.1 (NC)	≤ 2.2
Power consumption @ Ub = 24 V switched on, without load	mA	-	≤ 10
Permanent current	mA	≤ 100 (NO) ≤ 500 (NC)	≤ 100
Max. switching capacity	W	≤ 10	≤ 6
Switching frequency	Hz	≤ 400	≤ 1,000
Hysteresis	mT	≥ 0.2	typ. 0.7
EMC following EN 60947-5-2		yes	yes
Short-circuit protection		-	yes
Reverse polarity protection		yes	yes
Power-up pulse protection		-	yes
ATEX -Certification		-	on request
<b>Mechanical Characteristics</b>			
Housing		PA66	
Cable type		PUR / black	
Cable cross section	mm <sup>2</sup>	2 x 0.14	3 x 0.14
Bending radius fixed	mm	≥ 30	
Bending radius moving	mm	≥ 45	
<b>Ambient</b>			
Protection class to EN 60529	IP	67	
Ambient temperature range 1)	°C	- 25 to + 75	
Vibration to EN 60068-2-6	G	10 to 55 Hz, 1 mm	
Shock to EN 60068-2-27	G	30, 11 ms	

<sup>1)</sup> for the magnetic switch temperature range, please take into account the surface temperature and the self-heating properties of the linear drive.

## Linear Drive Accessories Ø 10 – 80 mm Magnetic Switches P8S-G

**OSP**  
ORIGA  
SYSTEM  
PLUS

Typ **RST**  
**EST**

The next generation of T-slot switches is appealing due to its ease of attachment without the use of special tools. Due to the new electronics, the hysteresis is especially narrow, allowing for a highly accurate switching point.

Magnetic switches are used for electrical sensing of the position of the piston, e.g. at its end positions. They can also be used for sensing of intermediate positions.

Sensing is contactless, based on magnets which are built-in as standard. A yellow LED indicates operating status.

The magnetic switches are attached with an adapter directly in the dovetail groove of the OSP cylinder.

With the Basic Guide BG, the magnetic switches are mounted directly in the T-slot.

**The possible operating speed of the load carrier or carrier bolt must account for the minimum response time of downstream devices. Accordingly, the switching distance is included in the calculation.**

$$\text{Minimum response time} = \frac{\text{Switching distance}}{\text{Overrun speed}}$$



For linear drives see overview see page 9-13

## Type RST

In the type RST contact is made by a mechanical **reed switch** encapsulated in glass.

## Type EST

In the type EST contact is made by an **electronic switch** – without bounce or wear and protected from pole reversal. The output is short circuit proof and insensitive to shocks and vibrations.

A cable with connector and open end can be ordered separately.

## Magnetic Switches RST and EST

### Electrical Service Life, Protective Measures

Magnetic switches are sensitive to excessive currents and inductions. With high switching frequencies and inductive loads such as relays, solenoid valves or lifting magnets, service life will be greatly reduced.

With **resistive and capacitive loads** with high switch-on current, such as light bulbs, a protective resistor should be fitted. This also applies to long cable lengths.

In the switching of inductive loads such as relays, solenoid valves and

lifting magnets, voltage peaks (transients) are generated which must be suppressed by protective diodes, RC loops or varistors.

### Connection Examples

- Load with protective circuits
- (a) Protective resistor for light bulb
- (b) Freewheel diode on inductivity
- (c) Varistor on inductivity
- (d) RC element on inductivity

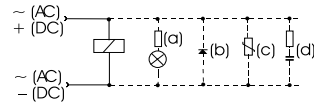

For the type EST, external protective circuits are not normally needed.

**Electrical Connection: cable**  
**Type RST-K**

Reed 2-wire

**Normally open**

**Normally closed**

**Electrical Connection: cable**  
**Type EST-K**

PNP 3-wire

**Normally open**

**Electrical Connection: plug**  
**Type RST-S**

Reed 2-wire

**Type EST-S**

PNP 3-wire

### Dimensions [mm] - Typ RST-K, EST-K - Series P8S-G

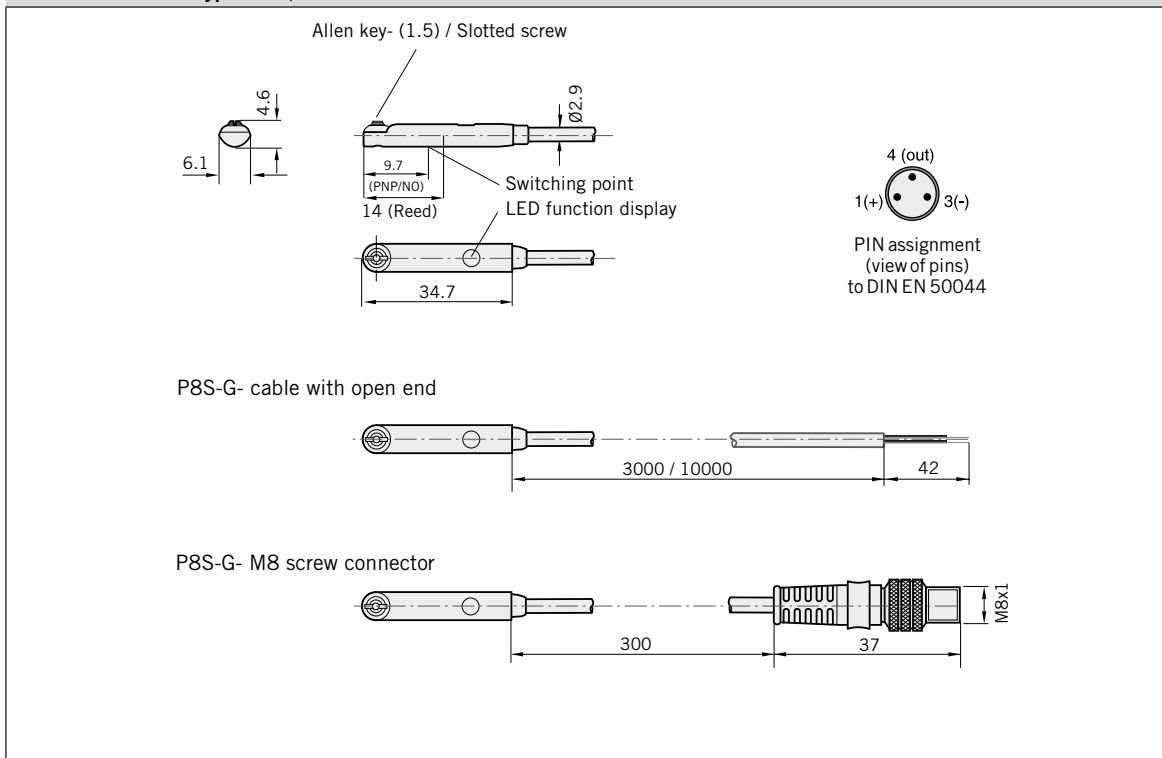

### Installation instructions for the RST/EST magnetic switches series P8S-G

Step 1:  
Insert magnetic switch  
into adapter



Step 2:  
Insert adapter into  
cylinder dovetail slot

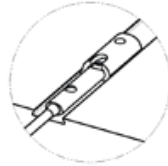

Step 3:  
Tighten screw:  
torque 0.15 Nm

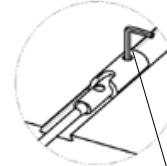

SW=1.5

### Dimensions adapters for RST/EST magnetic switch series P8S-G

for OSP-P10

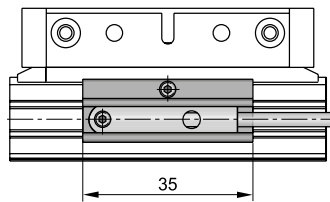
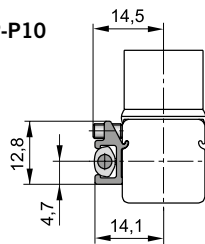

for OSP-P16-80

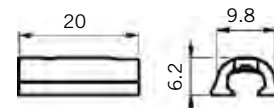

Note for OSP-P10: Switches can not be mounted directly opposite of the carrier !

### P8S-G mounting positions in the Basic Guide cylinder profile

Cylinder profile

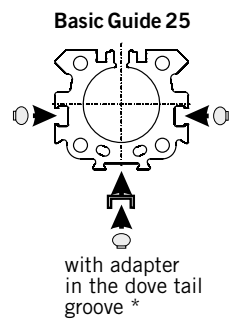

with adapter  
in the dove tail  
groove \*

Basic Guide 32

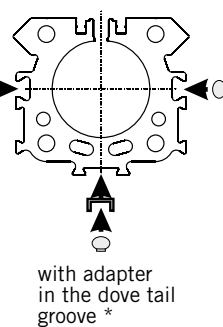

with adapter  
in the dove tail  
groove \*

Basic Guide 40

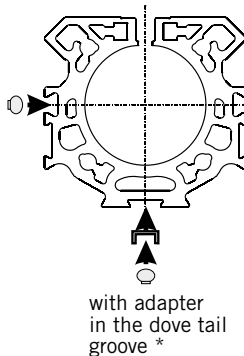

with adapter  
in the dove tail  
groove \*

Basic Guide 50

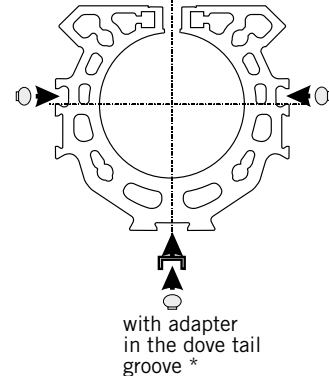

with adapter  
in the dove tail  
groove \*

\* Adapter is included in the scope of delivery of the P8S-G T-slot switches.

### Dimensions for P8S-G T-Slot magnetic switches with adapter in the cylinder profile of the Basic Guide 25-50

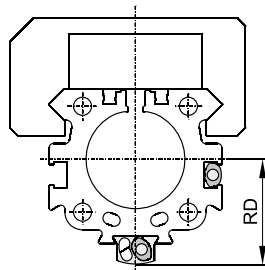

Series	Dimension [mm] RD
OSPP-BG25	27
OSPP-BG32	33.5
OSPP-BG40	39
OSPP-BG50	48

The right to introduce technical modifications is reserved

Order Instructions			
Version	Voltage	Type	Order No.
Magnetic switch, reed contact, normally open, LED indicator, cable 3 m	10-30 V AC / DC	RST-K	P8S-GRFAX
Magnetic switch, reed contact, normally open, LED indicator, cable 10 m	10-30 V AC / DC	RST-K	P8S-GRFDX
Magnetic switch, reed contact, normally open, screw connector M8, LED indicator, cable 0.3 m	10-30 V AC / DC	RST-S	P8S-GRCHX
Magnetic switch, reed contact, normally closed, cable 10 m	10-30 V AC / DC	RST-K	P8S-GEFRX
Magnetic switch, electronic, PNP LED indicator, cable 3 m	10-30 V DC	EST-K	P8S-GPFAX
Magnetic switch, electronic, PNP LED indicator, cable 10 m	10-30 V DC	EST-K	P8S-GPFDX
Magnetic switch, electronic, PNP screw connector M8, LED indicator, cable 0.3 m	10-30 V DC	EST-S	P8S-GPCHX

**Included in delivery:** 1 magnetic switch, 1 adapter for T-slot magnetic switch for type OSP-P16 up to OSP-P80.

**Note:** When using T-nut magnetic switches with the OSP-P10, please order the adapter Order No. 8872FIL separately.

Accessories		
Version	Type	Order No.
Cable M8, 2.5 m without lock nut	KS 25	KY 3240
Cable M8, 5.0 m without lock nut	KS 50	KY 3241
Cable M8, 10.0 m without lock nut	KS 100	KC 3140
Cable M8, 2.5 m with lock nut	KSG 25	KC 3102
Cable M8, 5.0 m with lock nut	KSG 50	KC 3104
Adapter for RST/EST magnetic switch – for type OSP-P10	HMTP010	8872FIL
Adapter for RST/EST magnetic switch – for type OSP-P16 up to OSP-P80		KL 9510

Magnetic switches ATEX version on request

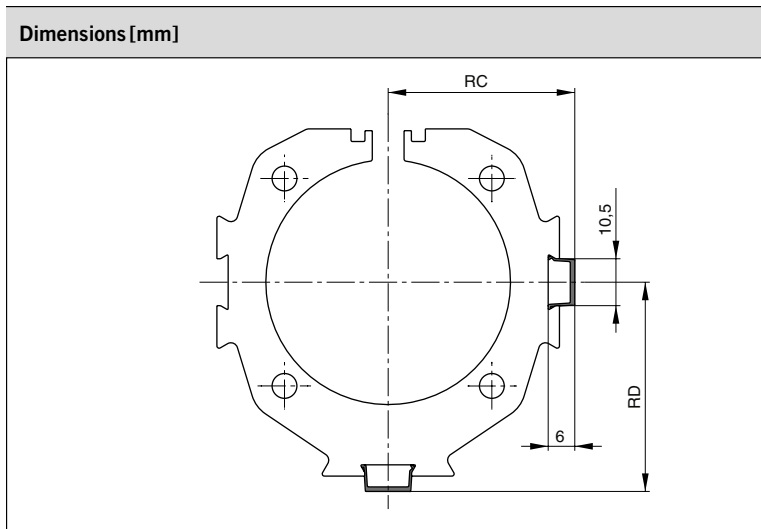

## Linear Drive Accessories

∅ 16-80 mm  
Cable Cover

Dimension Table [mm] and Order Instructions			
Series	Dimensions [mm]		Order No.
	RC	RD	
OSP-P16	18.5	19	<b>13039FIL</b>  Minimal length: 1 m Max. profile length: 2 m Multiple profiles can be used.
OSP-P25	23.5	25.5	
OSP-P32	29.5	32	
OSP-P40	34.5	37.5	
OSP-P50	41.5	46.5	
OSP-P63	51.5	57.5	
OSP-P80	64.5	70.5	

For clean guidance of magnetic switch cables along the cylinder body.  
Contains a maximum of 3 cables with diameter 3 mm.  
Material: Plastic  
Temperature Range: -10 to +80 °C

The right to introduce technical modifications is reserved

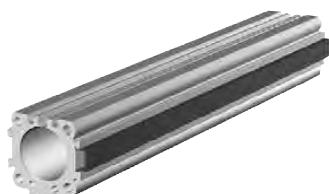



# ORIGA-SENSOFLEX Displacement Measuring System for Cylinder Series OSP-P



## Contents

Description	Page
Overview	130
Technical Data SFI-plus	131-132
Dimensions SFI-plus	132-133
Order Instructions SFI-plus	133

# ORIGA- Sensoflex

## Displacement measuring system for automated movement

**Series SFI-plus**  
(incremental measuring system)

for cylinder series

- OSP-P..

### Characteristics

- Contactless magnetic displacement measurement system
- Displacement length up to 32 m
- Resolution 0.1 mm (option: 1 mm)
- Displacement speed up to 10 m/s
- For linear and non-linear rotary motion
- Suitable for almost any control or display unit with a counter input

For further specifications,  
see page 132.



The SFI-plus magnetic displacement measuring system consists of 2 main components.

- **Measuring Scale**  
Self-adhesive magnetic measuring scale.

- **Sensing Head**  
Converts the magnetic poles into electrical signals which are then processed by counter inputs downstream (e.g. PLC, PC, digital counter)

Characteristics			
Characteristics	Unit	Description	
<b>Type</b>		21210FIL	21211FIL
Output Function			
Resolution	mm	0.1	1
Pole lengths magnetic scale	mm	5	
Maximum speed	m/s	10	
Repeat accuracy		± 1 Increment	
Distance between sensor and scale	mm	< 2	
Tangential deviation		≤ 3° / ≤ 1°	
Lateral deviation	mm	≤ ± 1.5	
Switching output		push / pull	
Electrical characteristics			
Operating voltage U <sub>b</sub>	V DC	10 – 30	
Voltage drop	V	≤ 2	
Continuous current for each output	mA	≤ 40	
Power consumption at U <sub>b</sub> = 24V, switched on, without load	mA	≤ 15	
Short-circuit protection		yes	
Reverse polarity protection		yes	
Protection from inductive load		yes	
EMC			
Emission standard for industrial		DIN EN 61000-6-4	
Immunity for industrial environments		DIN EN 61000-6-2	
Mechanical Characteristics			
Housing material		Aluminium	
Cable length	m	5.0 – casted, flying lead	
Cable cross section	mm <sup>2</sup>	2 x 0.14 + 2 x 0.22	
Cable type		PUR, black	
Bending radius, moving	mm	≥ 50	
Weight (mass)	kg	appr. 0.165	
Environmental Conditions / Shock Resistance			
Degree of protection	IP	67 to EN60529	
Ambient temperature range	°C	-25 to +85	
Vibration stress to EN 60068-2-6	m/s <sup>2</sup>	300, 55 Hz...2 kHz	
Shock to EN 60068-2-27	m/s <sup>2</sup>	300, 11 ms	

# Displacement measuring system

for automated movement

## ORIGA-Sensoflex (incremental displacement measuring system)

Series SFI-plus

for cylinder series

- OSP-P.

### Note:

For combinations Active Brake AB + SFI-plus + Magnetic Switch contact our technical department please.



### Sensing Head

The sensing head provides two pulsating, 90° out of phase counter signals (phase A/B) with a 0.1 mm resolution (option 1 mm).

The counting direction can be determined automatically from the phase variance of the counter signals.

Electrical Connection	
Colour	Function
red (RD)	10 ... 30 VDC
black (BK)	ground
yellow (YE)	signal A
green (GN)	signal B
shield	shielding

### SFI-plus mounted on a rodless cylinder series OSP-P

The SFI-plus system can be mounted directly on a rodless OSP-P cylinder with the special mounting kit. The position of the sensing head is generally 90° to the carrier.



Combinations consisting of SFI-plus and OSP-P Cylinders with guides are available on request.

### Dimensions [mm] – Sensing Head

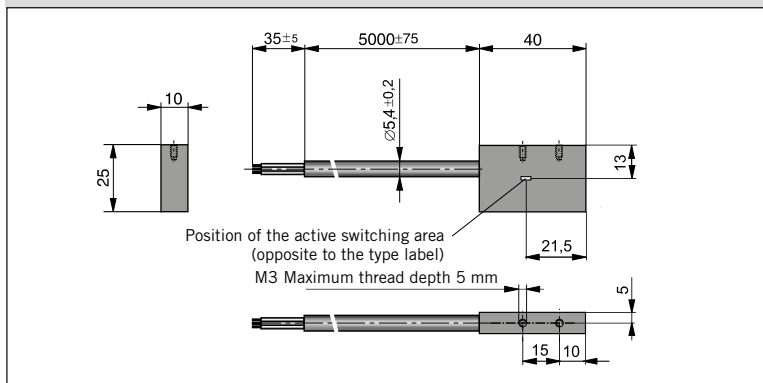

### Output signal – Sensing Head

$U_a = U_e$	Phase B	$U_{a1}$	0°	
	Phase A	$U_{a2}$	90°	

### Note: Impulse Frequency:

Pole distance of the magnetic measurement scale is 5 mm.

Impulse generation depends on the SFI-plus type used. The proportional output frequency of the signal impulses increases as the travel speed goes up.

The cycle frequency of the downstream counter input must be set accordingly.

Displacement measuring system	Resolution [mm]	Velocity [m/sec]	Output frequency [kHz]
SFI-plus 21210FIL	0.1	1	10
SFI-plus 21211FIL	1	1	1

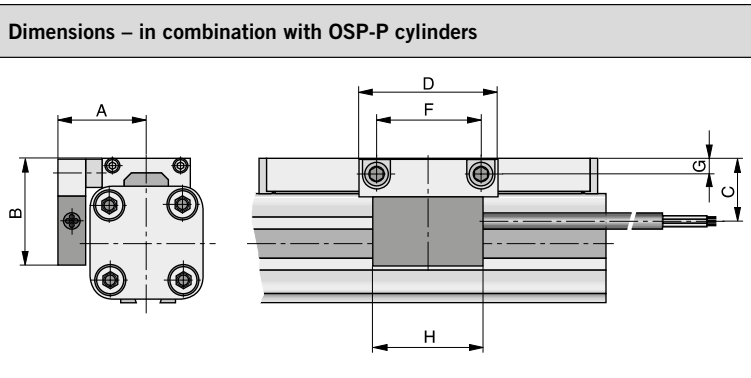

Dimension Table [mm]							
Serie	A	B	C	D	F	G	H
OSP-P25	31	43	23	50	38	5.5	40
OSP-P32	37	50	30	50	38	6.5	40
OSP-P40	42	54	34	50	38	6.5	40
OSP-P50	49	59	39	50	38	6.5	40
OSP-P63	59	73	49	50	38	10	40
OSP-P80	72	90	64	50	38	12	40

Order instructions	
Description	
Sensing head with measuring scale – Resolution 0.1 mm (please order overall length *)	<b>21240-measurement scale [mm], 5 digits</b>
Option: Sensing head with measuring scale – Resolution 1 mm (please order overall length *)	<b>21241-measurement scale [mm], 5 digits</b>
Sensing head – Resolution 0.1 mm (spare part)	<b>21210FIL</b>
Option: Sensing head – Resolution 1 mm (spare part)	<b>21211FIL</b>
Measuring scale per meter (spare part)	<b>21235FIL</b>
Mounting kit for OSP-P25	<b>21213FIL</b>
Mounting kit for OSP-P32	<b>21214FIL</b>
Mounting kit for OSP-P40	<b>21215FIL</b>
Mounting kit for OSP-P50	<b>21216FIL</b>
Mounting kit for OSP-P63	<b>21217FIL</b>
Mounting kit for OSP-P80	<b>21218FIL</b>

\* Overall length of the measuring scale results from stroke length of the cylinder + dead length  
Dead length for linear drives series OSP-P see table.

**Note:**  
Order instructions in combination with basic cylinder see page 24, pos. 25

Series	Dead length [mm]
OSP-P 25	154
OSP-P 32	196
OSP-P 40	240
OSP-P 50	280
OSP-P 63	350
OSP-P 80	422

**Example:**  
Cylinder OSP-P, Ø25 mm, stroke length 1000 mm

dead length + stroke length = overall length of the measuring scale  
**154 mm + 1000 mm = 01154 mm**

Please use this order pattern: 21240-01154

The right to introduce technical modifications is reserved

Total overview of options (not all of them can be combined !)							
1-4	5+6	7	8	9	10	11	12-16
OSPP	25	0	0	0	0	0	01100

Piston-Ø	Version / Piston	Air Connection	Seals	Lubrication	Screws	Stroke
10	0 standard	0 standard	0 standard (NBR)	0 standard	0 standard	Input in mm (5 digits)
16	1 Tandem	1 on the end face	1 Viton® <sup>1)</sup>	1 slow speed <sup>2)3)</sup>	1 stainless	
25	4 Clean room cylinder	2 both at one end (end caps are not turnable)				
32	6 ATEX Standard <sup>4)</sup>	3 left standard right end face				
40	C Classic	4 right standard left end face				
50	T Classic Tandem	7 Clean room				
63		A 3/2 way valve VOE 24 V= Ø 25, 32, 40, 50				
80		B 3/2 way valve VOE 230V~/110V= Ø 25, 32, 40, 50				
		C 3/2 way valve VOE 48V= Ø 25, 32, 40, 50				
		E 3/2 way valve VOE 110V~ Ø 25, 32, 40, 50				

<sup>1)</sup> Viton with VOE not possible.

<sup>2)</sup> "Slow speed lubrication" in combination with „Viton®“ seals on demand.

<sup>3)</sup> „Lubrication slow speed“ in combination with „max. cushioning length“ not possible.

<sup>4)</sup> Combination ATEX with VOE not possible.

	17	18	19	20	21	22	23	24	25
	0	0	0	0	0	0	0	0	0

End cap position		Cushioning		Piston Mounting		Guides/ Brakes/ Inversion		add. Guide Carriage		Cover / Cable Channel		Measuring system	
0	L+R 0° = in front	0	standard	0	without	0	without	0	without	0	standard	0	without
1	L+R 90° = underneath	1	max. length <sup>3)</sup>	1	Clevis mounting	2	Slideline SLXX	2	Guide Carriage Slideline SLXX	1	Cable channel	X	SFI 0.1 mm
2	L+R 180° = at the back	2	variable stop complete VS soft left only for Starline, KF and Heavy Duty guide	3	variable stop complete VS hard left only for Starline, KF and Heavy Duty guide	3	Slideline with Activebrake SL-ABXX	3	Guide Carriage Slideline Activebrake SL-ABXX	2	Cable channel two-sided	X	without Cover rail
3	L+R 270° = same side as outerband					4	Slideline with Passivebrake Multibrake SL-MBXX	4	Guide Carriage Slideline with Passivebrake Multibrake SL-MB				
4	L 90° = underneath; R 0° = in front	3	variable stop complete VS hard left only for Starline, KF and Heavy Duty guide	4	variable stop complete VS soft right only for Starline, KF and Heavy Duty guide	6	Proline PLXX	6	Guide Carriage Proline PLXX	7	Guide Carriage Proline Activebrake PL-ABXX	8	Guide Carriage Proline with Passivebrake Multibrake PL-MBXX
5	L 180° = at the back; R 0° = in front					7	Proline with Activebrake PL-ABXX	7	Guide Carriage Proline PL-ABXX				
6	L 270° = same side as outerband; R 0° = in front	4	variable stop complete VS soft both sides only for Starline, KF and Heavy Duty guide	5	variable stop complete VS hard right only for Starline, KF and Heavy Duty guide	8	Proline with Passivebrake Multibrake PL-MBXX	8	Guide Carriage Proline with Passivebrake Multibrake PL-MBXX	B	Guide Carriage Starline STLXX	C	Guide Carriage KFXX
7	L 0° = in front; R 90° = underneath					A	Activebrake ABXX						
8	L 180° = at the back; R 90° = underneath	6	variable stop complete VS soft both sides only for Starline, KF and Heavy Duty guide	6	variable stop complete VS hard both sides only for Starline, KF and Heavy Duty guide	B	Starline STLXX	D	Guide Carriage Heavy Duty HDXX	E	Guide Carriage Powerslide PSXX/25	F	Guide Carriage Powerslide PSXX/35
9	L 270° = same side as outerband; R 90° = underneath					C	KFXX						
A	L 0° = in front; R 180° = at the back	7	variable stop complete VS soft both sides only for Starline, KF and Heavy Duty guide	7	variable stop complete VS hard both sides only for Starline, KF and Heavy Duty guide	D	Heavy Duty HDXX	G	Guide Carriage Powerslide PSXX/44	H	Guide Carriage Powerslide PSXX/60	I	Guide Carriage Powerslide PSXX/76
B	L 90° = underneath; R 180° = at the back					E	PSXX/25 Powerslide						
C	L 270° = same side as outerband; R 180° = at the back	7	variable stop complete VS soft both sides only for Starline, KF and Heavy Duty guide	7	variable stop complete VS hard both sides only for Starline, KF and Heavy Duty guide	F	PSXX/35 Powerslide	M	Guide Carriage Slideline with Passivebrake Multibrake SL-MBXX without brake function	N	Guide Carriage Proline with Passivebrake Multibrake PL-MBXX without brake function		
D	L 0° = in front; R 270° = same side as outerband					G	PSXX/44 Powerslide						
E	L 90° = underneath; R 270° = same side as outerband	7	variable stop complete VS soft both sides only for Starline, KF and Heavy Duty guide	7	variable stop complete VS hard both sides only for Starline, KF and Heavy Duty guide	H	PSXX/60 Powerslide						
F	L 180° = at the back; R 270° = same side as outerband					I	PSXX/76 Powerslide						
						M	Inversion						
						N	Duplex						

The right to introduce technical modifications is reserved

## Parker Worldwide

### Europe, Middle East, Africa

**AE – United Arab Emirates,**  
Dubai

Tel: +971 4 8127100  
parker.me@parker.com

**AT – Austria,** Wiener Neustadt  
Tel: +43 (0)2622 23501-0  
parker.austria@parker.com

**AT – Eastern Europe,** Wiener  
Neustadt  
Tel: +43 (0)2622 23501 900  
parker.easteurope@parker.com

**AZ – Azerbaijan,** Baku  
Tel: +994 50 2233 458  
parker.azerbaijan@parker.com

**BE/LU – Belgium,** Nivelles  
Tel: +32 (0)67 280 900  
parker.belgium@parker.com

**BY – Belarus,** Minsk  
Tel: +375 17 209 9399  
parker.belarus@parker.com

**CH – Switzerland,** Etoy  
Tel: +41 (0)21 821 87 00  
parker.switzerland@parker.com

**CZ – Czech Republic,** Klecany  
Tel: +420 284 083 111  
parker.czechrepublic@parker.com

**DE – Germany,** Kaarst  
Tel: +49 (0)2131 4016 0  
parker.germany@parker.com

**DK – Denmark,** Ballerup  
Tel: +45 43 56 04 00  
parker.denmark@parker.com

**ES – Spain,** Madrid  
Tel: +34 902 330 001  
parker.spain@parker.com

**FI – Finland,** Vantaa  
Tel: +358 (0)20 753 2500  
parker.finland@parker.com

**FR – France,** Contamine s/Arve  
Tel: +33 (0)4 50 25 80 25  
parker.france@parker.com

**GR – Greece,** Athens  
Tel: +30 210 933 6450  
parker.greece@parker.com

**HU – Hungary,** Budapest  
Tel: +36 23 885 470  
parker.hungary@parker.com

**IE – Ireland,** Dublin  
Tel: +353 (0)1 466 6370  
parker.ireland@parker.com

**IT – Italy,** Corsico (MI)  
Tel: +39 02 45 19 21  
parker.italy@parker.com

**KZ – Kazakhstan,** Almaty  
Tel: +7 7272 505 800  
parker.easteurope@parker.com

**NL – The Netherlands,** Oldenzaal  
Tel: +31 (0)541 585 000  
parker.nl@parker.com

**NO – Norway,** Asker  
Tel: +47 66 75 34 00  
parker.norway@parker.com

**PL – Poland,** Warsaw  
Tel: +48 (0)22 573 24 00  
parker.poland@parker.com

**PT – Portugal,** Leca da Palmeira  
Tel: +351 22 999 7360  
parker.portugal@parker.com

**RO – Romania,** Bucharest  
Tel: +40 21 252 1382  
parker.romania@parker.com

**RU – Russia,** Moscow  
Tel: +7 495 645-2156  
parker.russia@parker.com

**SE – Sweden,** Spånga  
Tel: +46 (0)8 59 79 50 00  
parker.sweden@parker.com

**SK – Slovakia,** Banská Bystrica  
Tel: +421 484 162 252  
parker.slovakia@parker.com

**SL – Slovenia,** Novo Mesto  
Tel: +386 7 337 6650  
parker.slovenia@parker.com

**TR – Turkey,** Istanbul  
Tel: +90 216 4997081  
parker.turkey@parker.com

**UA – Ukraine,** Kiev  
Tel: +380 44 494 2731  
parker.ukraine@parker.com

**UK – United Kingdom,** Warwick  
Tel: +44 (0)1926 317 878  
parker.uk@parker.com

**ZA – South Africa,** Kempton Park  
Tel: +27 (0)11 961 0700  
parker.southafrica@parker.com

### North America

**CA – Canada,** Milton, Ontario  
Tel: +1 905 693 3000

**US – USA,** Cleveland  
Tel: +1 216 896 3000

### Asia Pacific

**AU – Australia,** Castle Hill  
Tel: +61 (0)2-9634 7777

**CN – China,** Shanghai  
Tel: +86 21 2899 5000

**HK – Hong Kong**  
Tel: +852 2428 8008

**IN – India,** Mumbai  
Tel: +91 22 6513 7081-85

**JP – Japan,** Tokyo  
Tel: +81 (0)3 6408 3901

**KR – South Korea,** Seoul  
Tel: +82 2 559 0400

**MY – Malaysia,** Shah Alam  
Tel: +60 3 7849 0800

**NZ – New Zealand,** Mt Wellington  
Tel: +64 9 574 1744

**SG – Singapore**  
Tel: +65 6887 6300

**TH – Thailand,** Bangkok  
Tel: +662 186 7000-99

**TW – Taiwan,** Taipei  
Tel: +886 2 2298 8987

### South America

**AR – Argentina,** Buenos Aires  
Tel: +54 3327 44 4129

**BR – Brazil,** Sao Jose dos Campos  
Tel: +55 800 727 5374

**CL – Chile,** Santiago  
Tel: +56 2 623 1216

**MX – Mexico,** Apodaca  
Tel: +52 81 8156 6000



#### Parker Hannifin GmbH

Pat-Parker-Platz 1  
41564 Kaarst (Germany)

Tel.: + 49 (0)2131 4016-0  
Fax: + 49 (0)2131 4016-9199  
Internet: www.parker.com  
E-Mail: parker.germany@parker.com