

Pneumatic Rodless Cylinders & Linear Guides

Catalog 0961-1

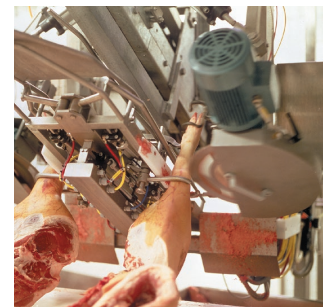

ENGINEERING YOUR SUCCESS.

Warning, Offer of Sale, Contents

OSP-P Series

- Bore sizes 10mm through 80mm
- Pressures to max. 8 bar
- Temperatures -10°F to 80°F
- Aluminum body construction

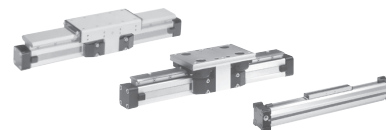

Pages 1-89

P1X Series

- 7 bore sizes 16mm through 63mm
- Integral sensor mounting rail
- Pressures 7 to 100 PSIG
- Temperatures 40°F to 140°F
- Aluminum body construction



Pages 91-109

GDL Rails & Cassettes

- 6 sizes available
- Speed up to 10m/s (33 ft/s)
- Temperatures -10°C to 80°C
- Aluminum alloy rail
- Aluminum body construction



Pages 111-124

2002 & P120 Series

- 2002 bore size: 16mm to 50mm
- P120 bore size: 40mm to 80mm
- Maximum pressure 120 PSI
- Temperatures 15°F to 175°F



Pages 125-160

P8S Electronic & Reed Sensors

(OSP & P1X Series)

- NPN, PNP, Reed
- NO, NC, 2 or 3 wire, LED
- Flying lead or M8 connector
- Continuous feedback: Analog, IO-Link



Pages 161-170

Accessories

- Mufflers, AirGuard, Check valves, Quick exhaust & shuttle valves, Threshold valves, Tank valves, Blow guns, Flow controls, Drains, Lockout valves



Pages 171-216

Part Number Index

Pages 217-223

Safety Guide, Offer of Sale

Pages 223-225

⚠ WARNING

FAILURE OR IMPROPER SELECTION OR IMPROPER USE OF THE PRODUCTS AND/OR SYSTEMS DESCRIBED HEREIN OR RELATED ITEMS CAN CAUSE DEATH, PERSONAL INJURY AND PROPERTY DAMAGE.

This document and other information from Parker Hannifin Corporation, its subsidiaries and authorized distributors provide product and/or system options for further investigation by users having technical expertise. It is important that you analyze all aspects of your application including consequences of any failure, and review the information concerning the product or system in the current product catalog. Due to the variety of operating conditions and applications for these products or systems, the user, through its own analysis and testing, is solely responsible for making the final selection of the products and systems and assuring that all performance, safety and warning requirements of the application are met.

The products described herein, including without limitation, product features, specifications, designs, availability and pricing, are subject to change by Parker Hannifin Corporation and its subsidiaries at any time without notice.

Offer of Sale

The items described in this document are hereby offered for sale by Parker Hannifin Corporation, its subsidiaries or its authorized distributors. This offer and its acceptance are governed by the provisions stated on the separate page of this document entitled "Offer of Sale".

© Copyright 2012, 2015, 2020 Parker Hannifin Corporation. All Rights Reserved



For inventory, lead times, and kit lookup, visit www.pdnplu.com

Parker Hannifin Corporation
Pneumatic Division
Wadsworth, OH
www.parkeroriga.com

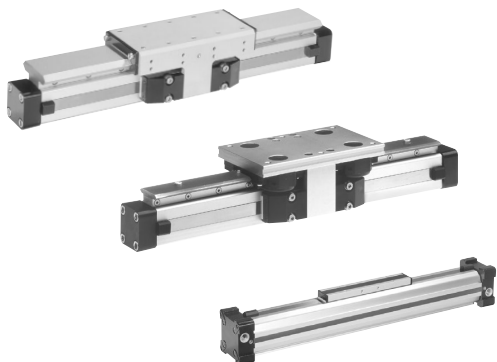

Rodless Pneumatic Cylinders OSP-P Series

OSP-P Series - Band Type Rodless

System Concept & Components	2-8
Standard Series	
Features	9-10
Ordering Information	11
Options / Technical Data	12-15
Dimensional Data	16-19
3/2 Way Valves VOE	20-21
Active Brake	22-23
Accessories	24-33
Clean Room	34-37
Bi-Parting	38-40
Linear Guides	
Features	41-42
SLIDELINE	43-47
POWERSLIDE	48-51
PROLINE	52-56
STARLINE	57-61
KF	62-68
HD	69-76
Linear Guide Accessories	77-84
Accessories	85-86
Sensoflex	87-88

Rodless Pneumatic Cylinders
OSP-P Series
P1X Series
GDL Series
2002/P120 Series
P55 Electronic & Reed Sensors
Accessories
Part Number Index
Safety Guide, Offer of Sale



For inventory, lead times, and kit lookup, visit www.pdnplu.com

Rodless Pneumatic Cylinders
OSP-P Series
P1X Series
GDL Series
2002/P120 Series
P55 Electronic & Reed Sensors
Accessories
Part Number Index
Safety Guide, Offer of Sale

OSP

Parker's rodless pneumatic cylinders are the first rodless cylinders that have been approved for use in potentially explosive atmospheres in Equipment Group II, Category 2 GD

The Cylinders are to the ATEX Certification 94/9/EG (ATEX 95) for Pneumatic Components.

ATTENTION!

Contact Parker for sizing software and/or technical assistance 877-321-4736

All dimensions are in European-Standard. Please convert all in US-Standard.

Conversion Table

Multiply	By	To Obtain
millimeters	.03937	inches
newtons	.2248	lbs.(F)
newton-meters	8.8512	in-lbs
kilograms	2.205	lbs.
inches	25.4	millimeters
lbs.(F)	4.448	newtons
in-lbs	.113	newtons-meters
lbs.	.45359	kilograms



for use in Ex-Areas



for Clean Room Applications certified to DIN EN ISO 14644-1



Stainless steel hardware for special applications

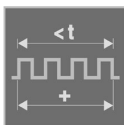

with special pneumatic cushioning system for cycle time optimization, for Ø 16 to 50 mm – on request



High Temperature Version for temperatures up to +100°C

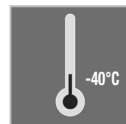

Low Temperature Version for temperatures up to -40°C (25, 32, 40mm Ø)



Slow Speed Version v = 0.005 – 0.2 m/s

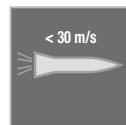

High Speed Version v_{max.} = 30 m/s (16, 25, 32mm Ø)

2D & 3D CAD Drawings can be downloaded from website www.parker.com/pneu/rodless



For inventory, lead times, and kit lookup, visit www.pdnplu.com

One Concept – Pneumatic

Based on the Parker's rodless cylinder, proven in world wide markets, Parker now offers the complete pneumatic solution for linear systems. Designed for absolute reliability, high performance, ease of use and optimized engineering the OSP SERIES satisfies even the most demanding applications.

OSP SERIES

is a totally modular concept which offers pneumatic actuation, with guidance options to suit the exact needs of individual installations.

The actuators at the core of the system all have a common aluminum extruded profile, with double dovetail mounting rails on three sides, these are the principle building blocks of the system to which all modular options are directly attached.

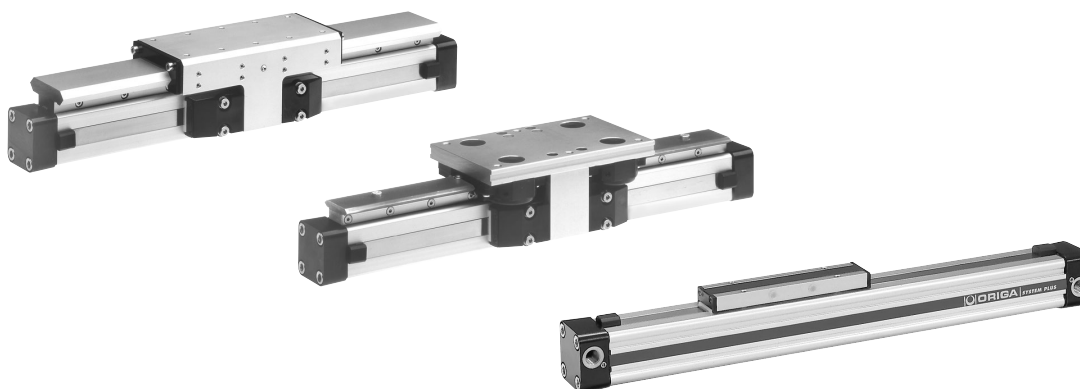

SYSTEM MODULARITY

- Pneumatic Drive
 - For all round versatility and convenience, combining ease of control and broad performance capability. Ideally suited for point-to point operations, reciprocating movements and simple traverse / transfer applications.
- Different guidance options provide the necessary level of precision, performance and duty for various applications.
- Compact solutions, which are simple to install and can be easily retrofitted.
- Valves and control options can be directly mounted to the actuator system.
- Diverse mounting options to provide total installation flexibility.

Rodless Pneumatic Cylinders
OSP-P Series
P1X Series
GDL Series
2002/P120 Series
P55 Electronic & Reed Sensors
Accessories
Part Number Index
Safety Guide, Offer of Sale



For inventory, lead times, and kit lookup, visit www.pdnplu.com

The System Concept

Rodless Pneumatic Cylinders
OSP-P Series
P1X Series
GDL Series
2002/P120 Series
P5S Electronic & Reed Sensors
Accessories
Part Number Index
Safety Guide, Offer of Sale

Basic Linear Drive



STANDARD VERSION

- OSP-P

Air Connection on the End-face or both at One End

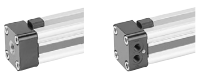

- OSP-P

Clean Room Cylinder certified to DIN EN ISO 146644-1

- Series OSP-P

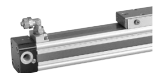

Bi-parting Version

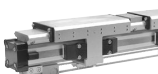

- OSP-P

Integrated 3/2 Way Valves



- OSP-P

Clevis Mounting



- OSP-P

End Cap Mounting



- OSP-P

Mid-Section Support



- OSP-P

Inversion Mounting



- OSP-P

Linear Guides

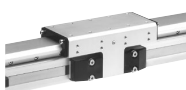

SLIDELINE

- OSP-P



POWERSLIDE

- OSP-P



PROLINE

- OSP-P



STARLINE

- OSP-P



KF - Recirculating Ball Bearing

- OSP-P

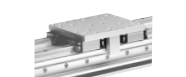

HD - Heavy Duty

- OSP-P

Intermediate Stop Module



ZSM

- OSP-P HD Guide (25 mm Bore Only)

Brakes



- Active Brakes
- Passive Brakes

Magnetic Switches



- OSP-P

SENSOFLEX - Measuring System



- SFI-plus

Variable Stop VS



- OSP-P with Linear Guide
STL, KF, HD



For inventory, lead times, and kit lookup, visit www.pdnplu.com

Catalog 0961-1
Modular Components Overview

Rodless Pneumatic Cylinders
OSP-P Series

Linear Drives	OSP-P10	OSP-P16	OSP-P25	OSP-P32	OSP-P40	OSP-P50	OSP-P63	OSP-P80
Specifications								
Theoretical Force at 6 bar (N)	47	120	295	483	754	1178	1870	3010
Effective Force at 6 bar (N)	32	78	250	420	640	1000	1550	2600
Velocity v (m/s)	> 0.005	> 0.005	> 0.005	> 0.005	> 0.005	> 0.005	> 0.005	> 0.005
Magnetic Piston (three sides)	<input type="checkbox"/>	<input type="checkbox"/>	<input type="checkbox"/>	<input type="checkbox"/>	<input type="checkbox"/>	<input type="checkbox"/>	<input type="checkbox"/>	<input type="checkbox"/>
Lubrication - Prelubricated	<input type="checkbox"/>	<input type="checkbox"/>	<input type="checkbox"/>	<input type="checkbox"/>	<input type="checkbox"/>	<input type="checkbox"/>	<input type="checkbox"/>	<input type="checkbox"/>
Multiple Air Ports (4 x 90°)	<input type="checkbox"/>	<input type="checkbox"/>	<input type="checkbox"/>	<input type="checkbox"/>	<input type="checkbox"/>	<input type="checkbox"/>	<input type="checkbox"/>	<input type="checkbox"/>
Both Air Connections at End-face	<input type="checkbox"/>	<input type="radio"/>	<input type="radio"/>	<input type="radio"/>	<input type="radio"/>	<input type="radio"/>	<input type="radio"/>	<input type="radio"/>
Air Connection on the End-face	<input type="checkbox"/>	<input type="radio"/>	<input type="radio"/>	<input type="radio"/>	<input type="radio"/>	<input type="radio"/>	<input type="radio"/>	<input type="radio"/>
Cushioning	<input type="checkbox"/>	<input type="checkbox"/>	<input type="checkbox"/>	<input type="checkbox"/>	<input type="checkbox"/>	<input type="checkbox"/>	<input type="checkbox"/>	<input type="checkbox"/>
Cushioning Length (mm)	2,50	11	17	20	27	30	32	39
Stroke Length (mm) ▲	1 - 5500	1 - 5500	1 - 5500	1 - 5500	1 - 5500	1 - 5500	1 - 5500	1 - 5500
Pressure Range pmax (bar)	8.0	8.0	8.0	8.0	8.0	8.0	8.0	8.0
Temperature Range (°C) ※	-10 – + 80	-10 – + 80	-10 – + 80	-10 – + 80	-10 – + 80	-10 – + 80	-10 – + 80	-10 – + 80
Fluorocarbon / Chemical Resistance	<input type="radio"/>	<input type="radio"/>	<input type="radio"/>	<input type="radio"/>	<input type="radio"/>	<input type="radio"/>	<input type="radio"/>	<input type="radio"/>
Stainless Steel Parts	<input type="radio"/>	<input type="radio"/>	<input type="radio"/>	<input type="radio"/>	<input type="radio"/>	<input type="radio"/>	<input type="radio"/>	<input type="radio"/>
Clevis Mounting	<input type="radio"/>	<input type="radio"/>	<input type="radio"/>	<input type="radio"/>	<input type="radio"/>	<input type="radio"/>	<input type="radio"/>	<input type="radio"/>
Slow Speed Lubrication	<input type="radio"/>	<input type="radio"/>	<input type="radio"/>	<input type="radio"/>	<input type="radio"/>	<input type="radio"/>	<input type="radio"/>	<input type="radio"/>
Duplex Connection / Multiplex Connection	<input type="checkbox"/>	on request	<input type="radio"/>	<input type="radio"/>	<input type="radio"/>	<input type="radio"/>	on request	on request
Tandem Piston	<input type="radio"/>	<input type="radio"/>	<input type="radio"/>	<input type="radio"/>	<input type="radio"/>	<input type="radio"/>	<input type="radio"/>	<input type="radio"/>
Basic Cylinder								
F (N)	20	120	300	450	750	1200	1650	2400
Mx (Nm)	0.2	0.45	1.5	3	6	10	12	24
My (Nm)	1	4	15	30	60	115	200	360
Mz (Nm)	0.3	0.5	3	5	8	15	24	48
SLIDELINE								
F (N)		325	675	925	1500	2000	2500	2500
Mx (Nm)		6	14	29	50	77	120	120
My (Nm)		11	34	60	110	180	260	260
Mz (Nm)		11	34	60	110	180	260	260
PROLINE								
F (N)		542	857	1171	2074	3111		
Mx (Nm)		8	16	29	57	111		
My (Nm)		12	39	73	158	249		
Mz (Nm)		12	39	73	158	249		
POWERSLIDE								
F (N)		1400	1400 - 3000	1400 - 3000	3000	3000 - 4000		
Mx (Nm)		14	14 - 65	20 - 65	65 - 90	90 - 140		
My (Nm)		45	63 - 175	70 - 175	175 - 250	250 - 350		
Mz (Nm)		45	63 - 175	70 - 175	175 - 250	250 - 350		
STARLINE								
F (N)		1000	3100	3100	4000-7500	4000-7500		
Mx (Nm)		15	50	62	150	210		
My (Nm)		30	110	160	400	580		
Mz (Nm)		30	110	160	400	580		
- Variable Stop		<input type="radio"/>	<input type="radio"/>	<input type="radio"/>	<input type="radio"/>	<input type="radio"/>		

- = Standard Version
- ▲ = Longer Strokes on Request
- ※ = Other Temperature Ranges on Request
- = Option
- X = Not Applicable

Rodless Pneumatic Cylinders
OSP-P Series
P1X Series
GDL Series
2002/P120 Series
P5S Electronic & Reed Sensors
Accessories
Part Number Index
Safety Guide, Offer of Sale



For inventory, lead times, and kit lookup, visit www.pdnplu.com

Cylinders	Linear Drives	OSP-P10	OSP-P16	OSP-P25	OSP-P32	OSP-P40	OSP-P50	OSP-P63	OSP-P80
		KF Guide							
Rodless Pneumatic Cylinders	F (N)		1000	3100	3100	4000-7500	4000-7500		
	Mx (Nm)		12	35	44	119	170		
	My (Nm)		25	90	133	346	480		
	Mz (Nm)		25	90	133	346	480		
	- Variable Stop		○	○	○	○	○		
	HD Heavy Duty Guide								
OSP-P Series	F (N)			6000	6000	15000	18000		
	Mx (Nm)			260	285	8000	1100		
	My (Nm)			320	475	1100	1400		
	Mz (Nm)			320	475	1100	1400		
	- Variable Stop			○	○	○	○		
	- Intermediate Stop Module			○					
	Active Brake								
P1X Series	Braking Force at 6 bar (brake surface dry) (N)								
	SLIDELINE SL / PROLINE PL with Brakes								
	Active Brake								
	SL Braking Force at 6 bar (brake surface dry) (N)			325	545	825	1200		
	PL Braking Force at 6 bar (brake surface dry) (N)			on request	on request	on request	on request		
	Passive Brake Multibrake								
	SL Braking Force at 6 bar (brake surface dry) (N)			470	790	1200	1870	2900	2900
	PL Braking Force at 6 bar (brake surface dry) (N)			315	490	715	1100		
	Magnetic Switches								
2002/P120 Series	Standard Version	○	○	○	○	○	○	○	○
	T-Nut Version	○	○	○	○	○	○	○	○
	Displacement Measuring Systems								
	SFI-plus Incremental			○	○	○	○	○	○
	Integrated Valves 3/2 WV NO VOE			○	○	○	○	on request	on request
	Mountings								
	End Cap Mounting / Mid-Section Support	○	○	○	○	○	○	○	○
	Inversion Mounting		○	○	○	○	○	○	○
	Shock Absorber for Intermediate Positioning			on request	on request	on request	on request		
	Adaptor Profile / T-Nut Profile		○	○	○	○	○		
	Special Cylinders								
	Special Pneumactical Cushioning System		on request	on request	on request	on request	on request		
	Clean Room Cylinders to DIN EN ISO 14644-1		○	○	○				
	Bi-parting Version					○			
	High-Speed up to 30 m/s		on request	on request	on request				
	□ = Standard Version								
	▲ = Longer Strokes on Request								
	* = Other Temperature Ranges on Request								
	○ = Option								
	X = Not Applicable								
Part Number Index									
Safety Guide, Offer of Sale									

 For inventory, lead times, and kit lookup, visit www.pdnplu.com

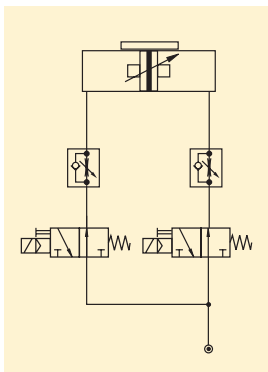

Circuit diagram for end of stroke application. Intermediate positioning is also possible.

The cylinder is controlled by two 3/2-way valves (normally open). The speed can be adjusted independently for both directions.

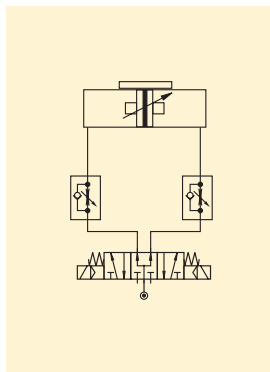

Circuit diagram for end of stroke application. Intermediate positioning is also possible.

The cylinder is controlled by a 5/3-way valve (middle position pressurized). The speed can be adjusted independently for both directions.

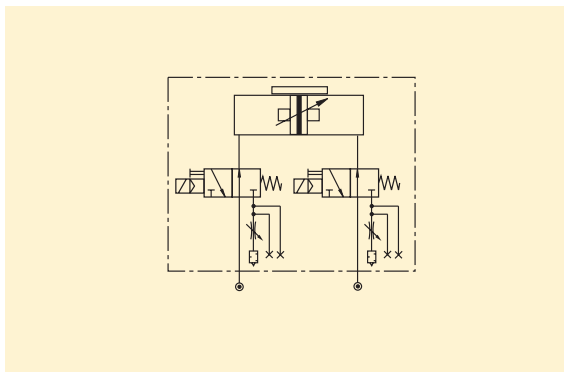

The optional integrated VOE Valves offer optimal control, and allow accurate positioning of intermediate positions and the lowest possible speeds.

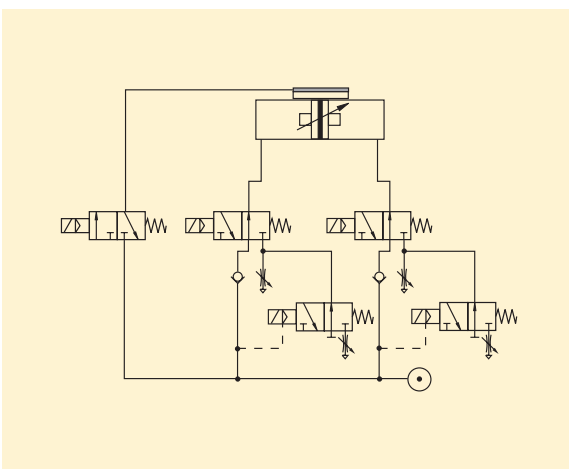

Fast/Slow speed cycle control with pneumatic brake for accurate positioning at high velocities. Additional 3/2-way valves with adjustable throttle valves at the exhaust of the standard directional control valves for two displacement speeds in each direction of the piston's travel.

The valve controlling the brake is activated after the slow speed cycle is activated.

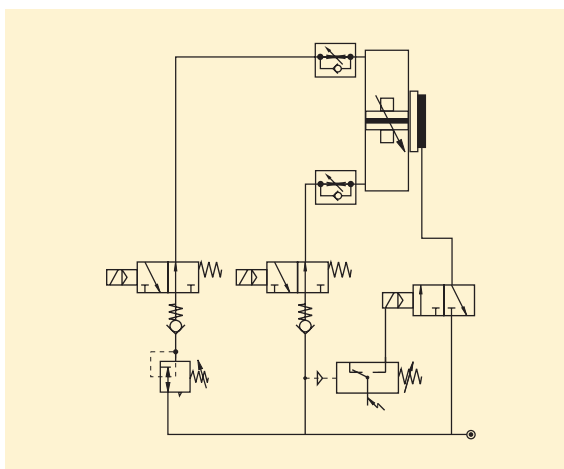

The combination of an OSP-cylinder with the passive MULTIBRAKE as shown here, allows accurate positioning and safety in case of loss of pneumatic air pressure.

Rodless Pneumatic Cylinders
OSP-P Series
P1X Series
GDL Series
2002/P120 Series
P55 Electronic & Reed Sensors
Accessories
Part Number Index
Safety Guide, Offer of Sale



For inventory, lead times, and kit lookup, visit www.pdnplu.com

OSP SERIES – rodless linear drives offer maximum flexibility for any application.

Rodless Pneumatic Cylinders
OSP-P Series
P1X Series
GDL Series
2002/P120 Series
P55 Electronic & Reed Sensors
Accessories
Part Number Index
Safety Guide, Offer of Sale

The high load capacity of the piston can cope with high bending moments without additional guides.

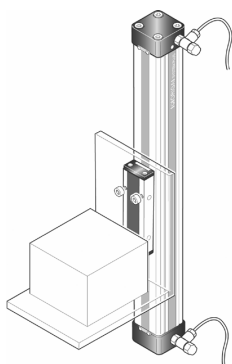

Integrated guides offer optimal guidance for applications requiring high performance, easy assembly and maintenance free operation.



The mechanical design of the OSP-P allows synchronized movement of two cylinders.

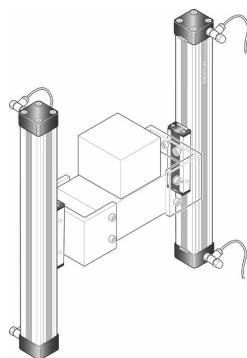

Optimal system performance by combining multi-axis cylinder combinations.

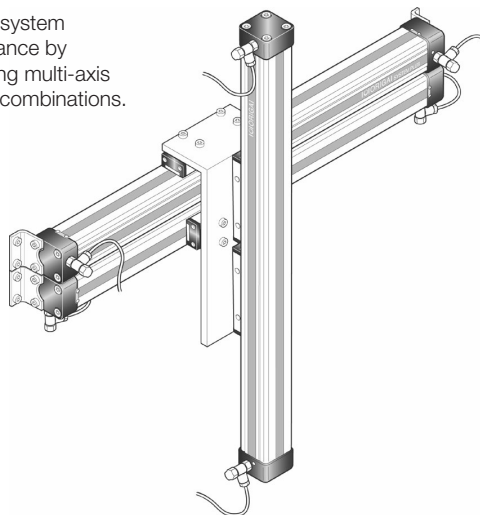

When using external guides, the clevis mounting is used to compensate for deviations in parallelism.

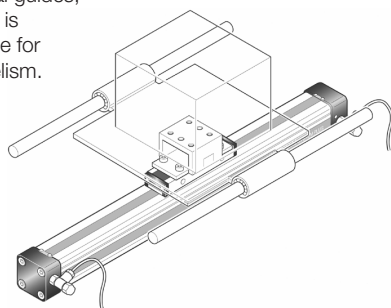

For further information and assembly instructions, please contact your local Parker dealer.



For inventory, lead times, and kit lookup, visit www.pdnplu.com

OSP-P Series

A new generation of linear drives which can be simply and neatly integrated into any machine layout.

A new modular linear drive system

With this second generation linear drive the OSP-P series offers design engineers complete flexibility.

The cylinder has been further developed into a combined linear actuator, guidance and control package. It forms the basis for the OSP-P linear drive system.

All additional functions are designed into modular system components which replace the previous series of cylinders.

Mounting rails on 3 sides

Mounting rails on 3 sides of the cylinder enable modular components such as linear guides, brakes, valves, magnetic switches etc. to be fitted to the cylinder itself. This solves many installation problems, especially where space is limited.

The modular system concept forms an ideal basis for additional customer-specific functions.

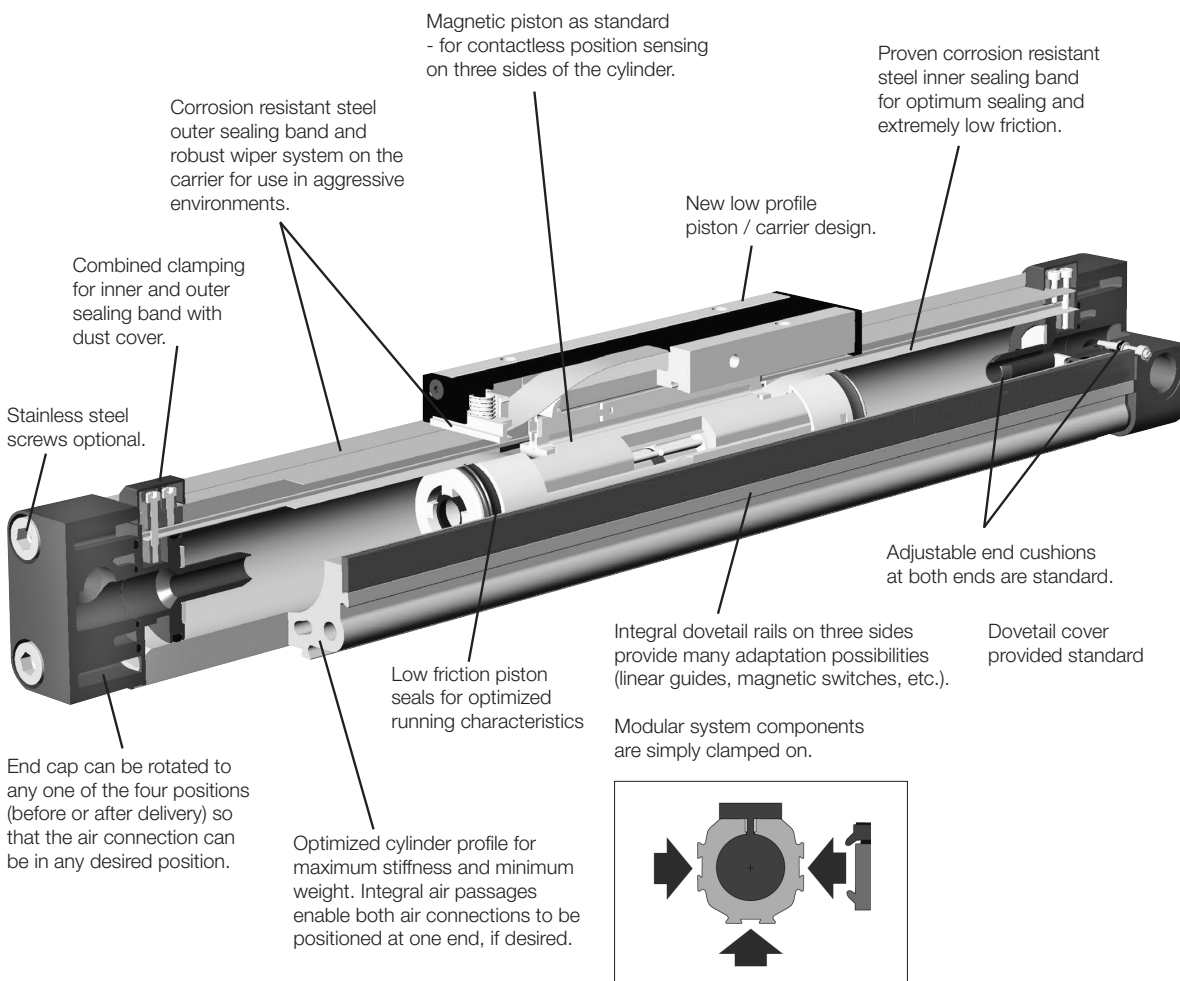

Rodless Pneumatic Cylinders
OSP-P Series
P1X Series
GDL Series
2002/P120 Series
P5S Electronic & Reed Sensors
Accessories
Part Number Index
Safety Guide, Offer of Sale



For inventory, lead times, and kit lookup, visit www.pdnplu.com

Features
Standard Features:

- Double-acting with adjustable cushions
- With magnetic piston for position sensing
- Standard stroke lengths to 5500mm, long stroke versions available upon request
- End cap can be rotated 4 x 90° to position ports as desired

Optional Features:

- Clean room cylinders
- Stainless steel screws
- 0.005 to 0.2 M/S
- Fluorocarbon seals -14°F to 212°F (-10°C to 100°C)
- Single end porting
- Integrated valves
- Integrated bearing options

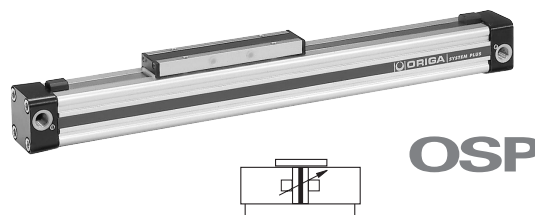
Operating information

Operating pressure:	116 PSIG (8 bar)
Temperature range:	14°F to 176°F (-10°C to 80°C)
Filtration requirements:	Filtered, nonlubricated compressed air

Specifications

- Type Rodless cylinder
- Series OSP-P
- Stroke length 5.5m (216 inches)
- System Double-acting, with cushions and magnetic piston
- Mounting See drawings
- Air connection Threaded
- Weight (mass) See table
- Installation In any position
- Lubrication Prelubricated at the factory (additional oil mist lubrication not required)
- Option: special slow speed grease

Material specifications

Cylinder profile	Anodized aluminum
Carrier (piston)	Anodized aluminum
End caps	Aluminum, lacquered / plastic (P10)
Sealing bands	Corrosion resistant steel
Seals	NBR (Option: Fluorocarbon)
Screws	Galvanized steel Option: stainless steel
Dust covers, wipers	Composite

Weight (mass) kg

Cylinder Series (Basic Cylinder)	Weight (Mass) kg	
	at 0mm Stroke	per 100mm Stroke
OSP-P10	0.087	0.052
OSP-P16	0.22	0.1
OSP-P25	0.65	0.197
OSP-P32	1.44	0.354
OSP-P40	1.95	0.415
OSP-P50	3.53	0.566
OSP-P63	6.41	0.925
OSP-P80	12.46	1.262

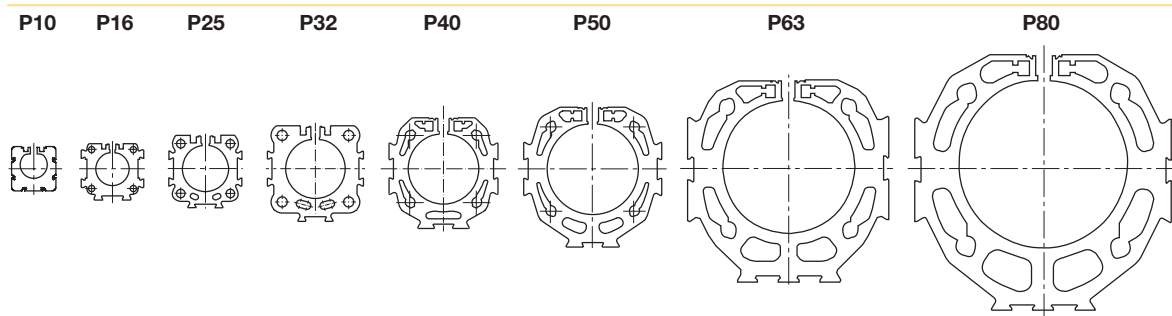
Size Comparison

 For inventory, lead times, and kit lookup, visit www.pdnplu.com

Ordering information for OSP-P rodless standard pneumatic series

1-4	5-6	7	8	9	10	11	12-16	17	18	19	20	21	22	23	24	25
OSPP	25	0	1		0	0		0	0	0	0	0	0	1	0	0

Bore
10
16
25
32
40
50
63
80

Piston Style
0 Standard
1 Tandem
C Classic
T Tandem Classic

Seals
0 Standard / Buna-N
1 Fluorocarbon

Hardware
0 Standard / Zinc
1 Stainless Steel

Porting Configurations †
0 Standard
1 End Face (16,25,32,40,50,63,80)
2 Single End Porting (25,32,40,50,63,80)
3 Left Std Pos #2, Right Pos #5 (16,25,32,40,50,63,80)
4 Left Pos #5, Right Std Pos #2 (16,25,32,40,50,63,80)
6 Single End Porting at #5 (50,63,80)
8 Inner Band Temp Compensation (25,32,40,80)
A 24VDC VQE Valves (25,32,40,50)
B 220VAC VQE Valves (25,32,40,50)
C 48VDC VQE Valves (25,32,40,50)
E 110VAC VQE Valves (25,32,40,50)

Notes: 10mm bore can only have standard port locations.
 Single end porting on 16mm bore, then end caps cannot be rotated.

Stroke
x x x x x

5 digits in whole millimeters (ex. 1100mm = 01100)

Lubrication
0 Standard
1 Slow Speed
4 Food
5 Clean Room

Cushioning & Stops
0 Standard
1 Long Cushions (25,32,40)

Piston Mounting
0 Standard
1 Floating Mount

Guides / Brakes
0 None
A Activebrake (16 thru 80)
M Inversion (NR30) (16 thru 80mm bore only)

Endcap Position
0 Both Pos #2
1 Both Pos #3
2 Both Pos #4
3 Both Pos #1
4 Left #3 / Right #2
5 Left #4 / Right #2
6 Left #1 / Right #2
7 Left #2 / Right #3
8 Left #4 / Right #3
9 Left #1 / Right #3
A Left #2 / Right #4
B Left #3 / Right #4
C Left #1 / Right #4
D Left #2 / Right #1
E Left #3 / Right #1
F Left #4 / Right #1

Notes: 10mm bore only available on option "0".

Dovetail cover
0 Standard
X Without Cover Rail

Version
0 Standard

Additional Carriages
0 None

Endcap Mounting
0 None
1 A1 (10,16,25,32)
2 A2 (16,25,32)
3 A3 (25,32)
4 B1 (25,32)
6 B3 (16)
7 B4 (25,32)
8 B5 (32)
9 C1 (40,50,63,80)
A C2 (40,50,63,80)
B C3 (40,50,63,80)
C C4 (40,50,63,80)

Note: Comes in pairs

Switches †
0 None
1 Normally Open Reed Switch (16 thru 80)
2 Normally Closed Reed Switch (16 thru 80)
3 PNP Hall Sensor w/Extension Cables (16 thru 80)
4 NPN Hall Sensor w/Extension Cables (16 thru 80)
5 NO Reed, w/10mm Bracket (10 only)
6 PNP Hall Sensor w/Extension Cables & 10mm Brackets (10mm only)
7 NPN Hall Sensor w/Extension Cables & 10mm Brackets (10mm only)
X SFI 0.1mm RES (25 thru 80)
Y SFI 1mm RES (25 thru 80)

† Note: 2 switches will be supplied.
 For different quantity, please order as a separate line item.

Diagram

Note: Position #2 is the standard location.

† Single end ports can not be rotated in the field

Rodless Pneumatic Cylinders
OSP-P Series
P1X Series
GDL Series
2002/P120 Series
P55 Electronic & Reed Sensors
Accessories
Part Number Index
Safety Guide, Offer of Sale



For inventory, lead times, and kit lookup, visit www.pdnplu.com

Rodless Pneumatic Cylinders
OSP-P Series
P1X Series
GDL Series
2002/P120 Series
P55 Electronic & Reed Sensors
Accessories
Part Number Index
Safety Guide, Offer of Sale

Plain Bearing Guide SLIDELINE

Available on 16 to 80mm bore

Features:

- Adjustable composite slide elements – optional integral brake
- Integrated sealing system with wiper elements to remove dirt and lubricate the slideways
- Any length of stroke up to 5500mm

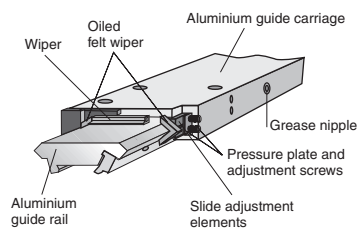
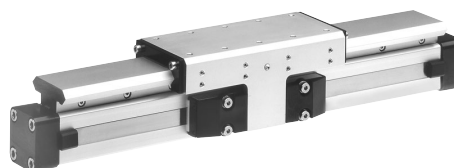

Roller Guide POWERSLIDE

Available on 16 to 50mm bore

Features:

- Anodized aluminum guide carriage with vee rollers
- Hardened steel guide rail
- Multiple guide sizes can be used on the same drive
- Max. Speed $v = 3 \text{ m/s}$
- Integrated wiper and grease nipple
- Any length of stroke up to 3500mm

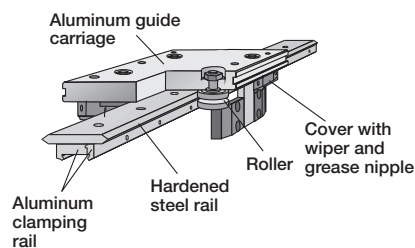
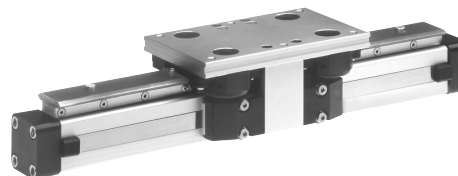

For inventory, lead times, and kit lookup, visit www.pdnplu.com

Other Options



PROLINE

The compact aluminum roller guide for high loads and velocities and utilizes the GDL Guide Bearing



STARLINE

Recirculating ball bearing guide for very high loads and precision

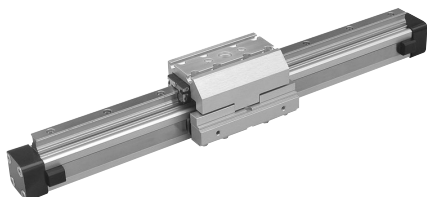

KF Guide

Recirculating ball bearing guide – the mounting dimensions correspond to FESTO Type: DGPL-KF

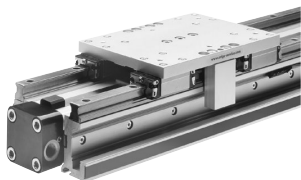

Heavy Duty Guide HD

For heavy duty applications



Integrated VOE Valves



SENSOFLEX SFI-plus

Incremental measuring system with 0.1 (1.0) mm resolution

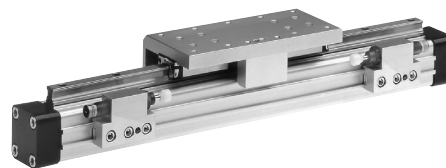

Variable Stop VS

The variable stop provides simple stroke limitation
Available on STARLINE, KF and Heavy duty guide



Clean Room Version

Certified to DIN EN ISO 14644-1

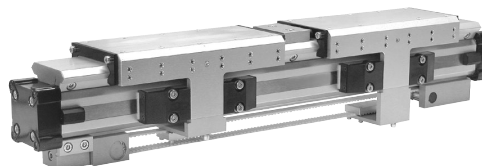

Rodless Cylinder

For synchronized bi-parting movements
Available on SLIDELINE Guide Bearing only

Rodless Pneumatic Cylinders
OSP-P Series
P1X Series
GDL Series
2002/P120 Series
P55 Electronic & Reed Sensors
Accessories
Part Number Index
Safety Guide, Offer of Sale



For inventory, lead times, and kit lookup, visit www.pdnplu.com

Rodless Pneumatic Cylinders

OSP-P Series

P1X Series

GDL Series

2002/P120 Series

P55 Electronic & Reed Sensors

Accessories

Part Number Index

Safety Guide, Offer of Sale

Loads, Forces and Moments

When sizing an OSP cylinder, consideration must be given to:

- Loads, forces and moments
- Performance of the pneumatic end cushions. The main factors are the mass to be cushioned and the piston speed (unless external cushioning is used, e. g. hydraulic shock absorbers)

$$\frac{L}{[L]} + \frac{M}{[M]} + \frac{Ms}{[Ms]} + \frac{Mv}{[Mv]} = LMF \leq 1.0$$

$$\frac{M}{[M]} + \frac{Ms}{[Ms]} + \frac{Mv}{[Mv]} = LMF \leq 1.0$$

To determine the maximum values for light, shock-free operation, which must not be exceeded even in dynamic operation.

Load and moment data are based on speeds $v \leq 0.5$ m/s.

When working out the action force required, it is essential to take into account the friction forces generated by the specific application or load.

The sum total of each of these types of moments, divided by each of the maximum values, determines a Load-Moment Factor (LMF) should be equal to or less than 1.0. On horizontal mountings, the total load (L) should also be divided by the maximum load allowable and factored into the equation.

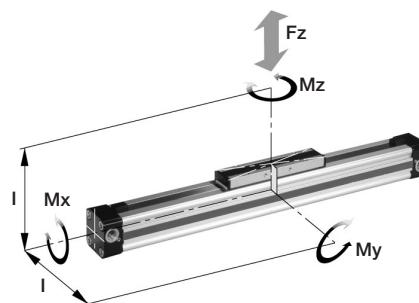

$$M = F \cdot l$$

Bending moments are calculated from the center of the linear actuator

Cylinder Series (mm Ø)	Theoretical Output Force at 6 Bar N (lb)	Actual Output Force F_A at 6 Bar N (lb)	Max. Moments			Max. Load F N (lb)	Cushion Length (mm)
			Mx Nm (in lb)	My Nm (in lb)	Mz Nm (in lb)		
OSP-P10	47 (10.6)	32 (7.2)	0.2 (1.8)	1 (8.9)	0.3 (2.7)	20 (4.5)	2.5 * (.09)
OSP-P16	120 (26.9)	78 (17.5)	0.45 (3.9)	4 (35.4)	0.5 (4.4)	120 (26.9)	11 (.43)
OSP-P25	295 (66.3)	250 (56.2)	1.5 (13.3)	15 (132.8)	3 (26.6)	300 (67.4)	17 (.67)
OSP-P32	483 (108.6)	420 (94.4)	3 (26.6)	30 (265.5)	5 (44.3)	450 (101.2)	20 (.79)
OSP-P40	754 (169.5)	640 (143.9)	6 (53.1)	60 (531)	8 (70.8)	750 (168.6)	27 (1.06)
OSP-P50	1178 (264.8)	1000 (224.8)	10 (88.5)	115 (1017.8)	15 (132.8)	1200 (269.8)	30 (1.18)
OSP-P63	1870 (420.4)	1550 (348.5)	12 (106.2)	200 (1771)	24 (212.4)	1650 (370.9)	32 (1.26)
OSP-P80	3016 (678)	2600 (584.5)	24 (212.4)	360 (3186)	48 (424.8)	2400 (539.5)	39 (1.54)

* A rubber element (non-adjustable) is used for end cushioning.
 To deform the rubber element enough to reach the absolute end position would require a Δp of 4 bar!

Cushioning diagram

Determine the moving mass and follow the chart below to determine the maximum cylinder velocity.

Alternatively, take your desired velocity and moving mass to determine the required cylinder diameter.

If these maximum permissible values are exceeded, additional shock absorbers must be used.

For sizing a basic cylinder, use the adjacent chart. To size a cylinder with guide bearing, use the charts on the following page.

The peak piston velocity can be determined by assuming it is 50% greater than the average velocity. The peak velocity should be used in sizing the cylinder cushions.

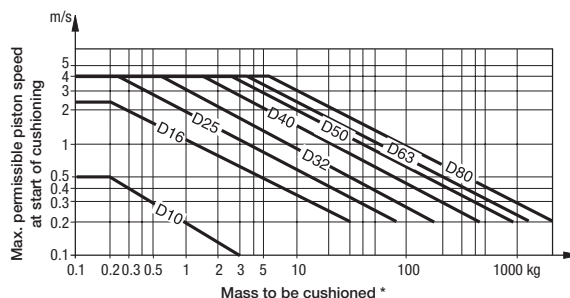

Includes piston mass.

* For cylinders with linear guides or brakes, please be sure to take the mass of the carriage or the brake housing into account.



For inventory, lead times, and kit lookup, visit www.pdnplu.com

Mid-Section Supports

To avoid excessive bending and oscillation of the cylinder, intermediate supports may be required. The diagrams below show the maximum permissible support spacing based upon load.

Bending up to 0.5 mm is permissible between supports. The mid-section supports are clamped on to the dovetail profile of the cylinder tube. They are also able to take the axial forces.

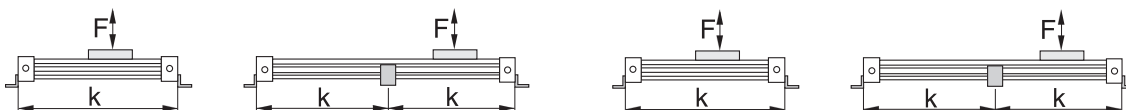

Basic cylinder 10 to 32mm bore mid-section supports

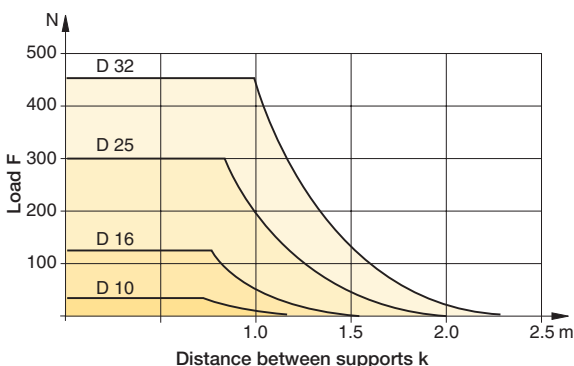

Basic cylinder 40 to 80mm bore mid-section supports

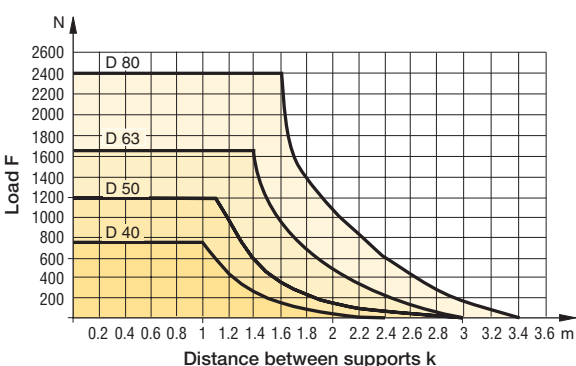

Rodless Pneumatic Cylinders
OSP-P Series
P1X Series
GDL Series
2002/P120 Series
P55 Electronic & Reed Sensors
Accessories
Part Number Index
Safety Guide, Offer of Sale



For inventory, lead times, and kit lookup, visit www.pdnplu.com

Rodless Pneumatic Cylinders
OSP-P Series
P1X Series
GDL Series
2002/P120 Series
P5S Electronic & Reed Sensors
Accessories
Part Number Index
Safety Guide, Offer of Sale

Cylinder Stroke and Dead Length A

- Free choice of stroke length up to 5500mm in 1mm steps.
- Longer strokes available on request.

Tandem Cylinder

Two pistons are fitted : dimension "Z" is optional. Please note minimum distance "Zmin".

- Free choice of stroke length up to 5500mm in 1mm steps.
- Longer strokes available on request.
- Stroke length to order is stroke + dimension "Z".

Please note:

To avoid multiple actuation of magnetic switches, the second piston is not equipped with magnets.

Basic cylinder – 10mm bore

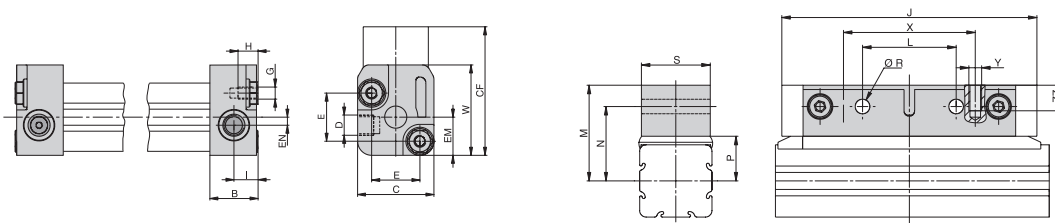
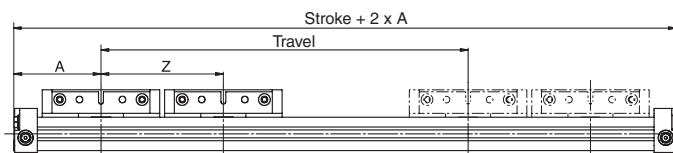
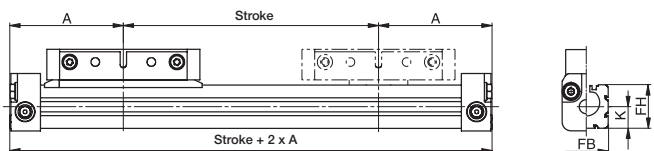

Dimensions (mm)

Series	A	B	C	D	E	G	H	I	J	K	L	M	N	P	R	S	W	X	Y	Zmin	CF	EM	EN	FB	FH	ZZ
OSP-P10	44.5	12	19	M5	12	M3	5	6	60	8.5	22	22.5	17.5	10.5	3.4	16	22.5	31	M3	64	32	9.5	2	17	17	6



For inventory, lead times, and kit lookup, visit www.pdnplu.com

Cylinder Stroke and Dead Length A

- Free choice of stroke length up to 5500mm in 1mm steps.
- Longer strokes available on request.

Tandem Cylinder

Two pistons are fitted : dimension "Z" is optional. Please note minimum distance "Zmin".

- Free choice of stroke length up to 5500mm in 1mm steps.
- Longer strokes available on request.
- Stroke length to order is stroke + dimension "Z".

Please note:

To avoid multiple actuation of magnetic switches, the second piston is not equipped with magnets.

Basic cylinder – 16 to 80mm bore

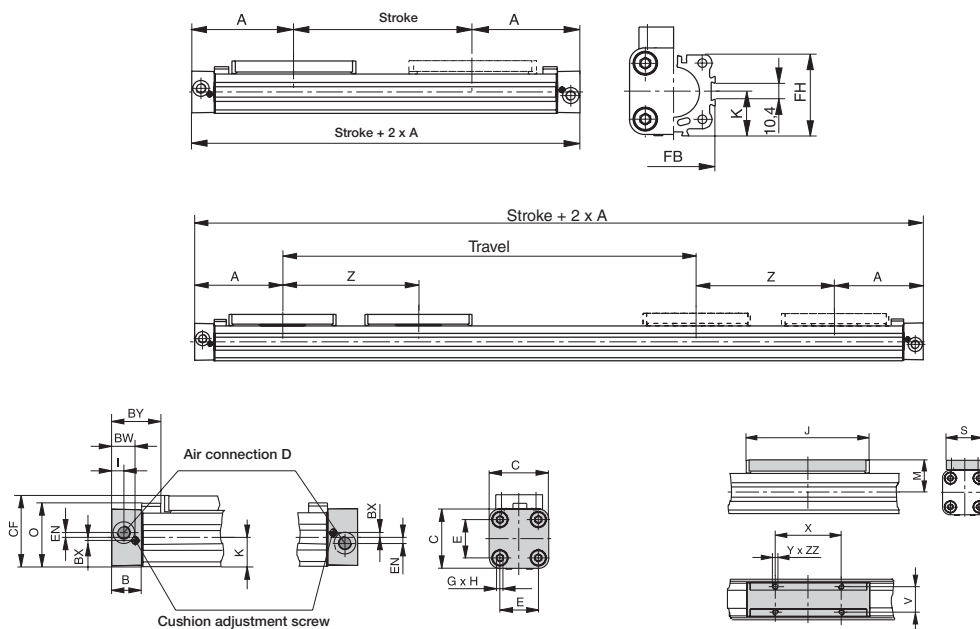

Dimensions (mm)

Series	A	B	C	D	E	G	H	I	J	K	M	O	S	V	X	Y	Z	BW	BX	BY	CF	EN	FB	FH	ZZ
OSP-P16	65	14	30	M5	18	M3	9	5.5	69	15	23	33.2	22	16.5	36	M4	81	10.8	1.8	28.4	38	3	30	27.2	7
OSP-P25	100	22	41	G1/8	27	M5	15	9	117	21.5	31	47	33	25	65	M5	128	17.5	2.2	40	52.5	3.6	40	39.5	8
OSP-P32	125	25.5	52	G1/4	36	M6	15	11.5	152	28.5	38	59	36	27	90	M6	170	20.5	2.5	44	66.5	5.5	52	51.7	1
OSP-P40	150	28	69	G1/4	54	M6	15	12	152	34	44	72	36	27	90	M6	212	21	3	54	78.5	7.5	62	63	10
OSP-P50	175	33	87	G1/4	70	M6	15	14.5	200	43	49	86	36	27	110	M6	251	27	-	59	92.5	11	76	77	10
OSP-P63	215	38	106	G3/8	78	M8	21	14.5	256	54	63	107	50	34	140	M8	313	30	-	64	117	12	96	96	16
OSP-P80	260	47	132	G1/2	96	M10	25	22	348	67	80	133	52	36	190	M10	384	37.5	-	73	147	16.5	122	122	20

Rodless Pneumatic Cylinders
OSP-P Series
P1X Series
GDL Series
2002/P120 Series
P55 Electronic & Reed Sensors
Accessories
Part Number Index
Safety Guide, Offer of Sale



For inventory, lead times, and kit lookup, visit www.pdnplu.com

Rodless Pneumatic Cylinders
OSP-P Series
P1X Series
GDL Series
2002/P120 Series
P55 Electronic & Reed Sensors
Accessories
Part Number Index
Safety Guide, Offer of Sale

Air Connection on the End-Face #5

In some situations it is necessary or desirable to fit a special end cap with the air connection on the end-face instead of the standard end cap with the air connection on the side. The special end cap can also be rotated 4 x 90° to locate the cushion adjustment screw as desired.



Series OSP-P16 to P32

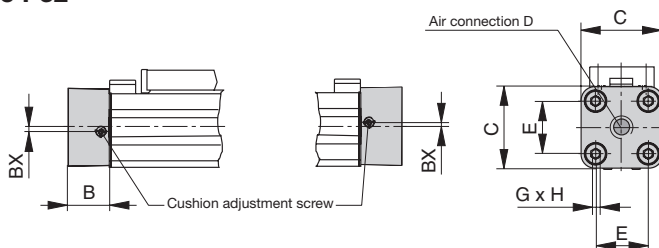

Series OSP-P40 to P80

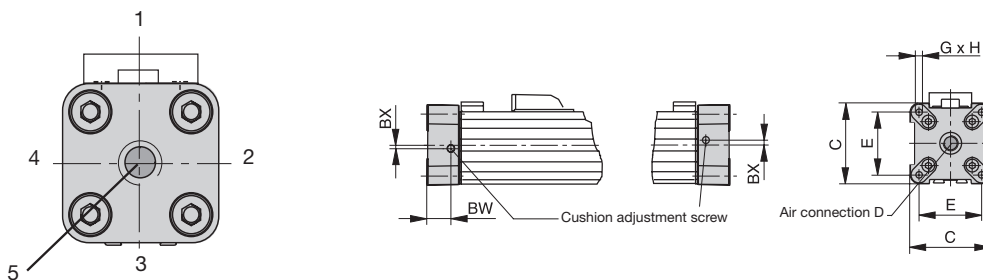

Note: Position #2 is the standard location.

Dimension (mm)

Series	B	C	D	E	G	H	BX	BW
OSP-P16	14	30	M5	18	M3	9	1.8	10.8
OSP-P25	22	41	G1/8	27	M5	15	2.2	17.5
OSP-P32	25.5	52	G1/4	36	M6	15	2.5	20.5
OSP-P40	28	69	G1/4	54	M6	15	3	21
OSP-P50	33	87	G1/4	70	M6	15	-	27
OSP-P63	38	106	G3/8	78	M8	21	-	30
OSP-P80	47	132	G1/2	96	M10	25	-	37.5



For inventory, lead times, and kit lookup, visit www.pdnplu.com

Single End Porting

A special end cap with both air connections on one side is available for situations where shortage of space, simplicity of installation or the nature of the process make it desirable. Air supply to the other end is via internal air passages (OSP-P25 to P80) or via a hollow aluminum profile fitted externally (OSP-P16).



In this case the end caps cannot be rotated.

Please note:

When combining the OSP-P16 single end porting with inversion mountings, RS magnetic switches can only be mounted directly opposite to the external air-supply profile.

Series OSP-P16

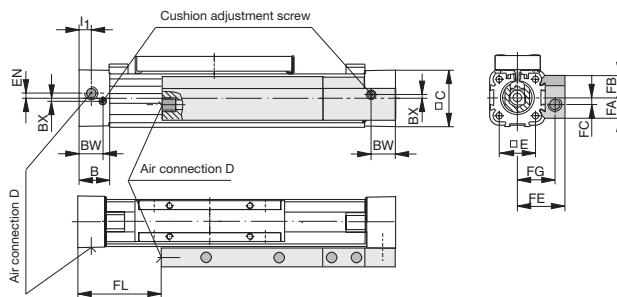

Series OSP-P25

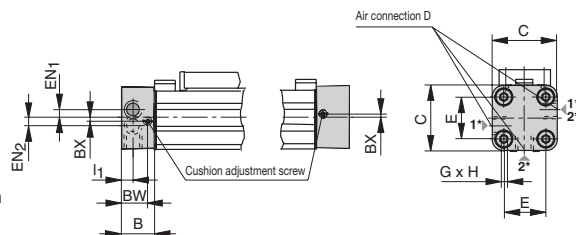

* Versions of Air Connection
 Positions: 1 → 1 or
 2 → 2

Series OSP-P32 to P80

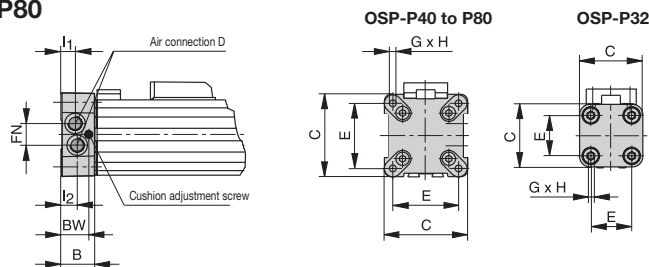

Dimension (mm)

Series	B	C	D	E	G	H	I1	I2	BX	BW	EN	EN1	EN2	FA	FB	FC	FE	FG	FL	FN
OSP-P16	14	30	M5	18	M3	9	5.5	-	1.8	10.8	3	-	-	12.6	12.6	4	27	21	36	-
OSP-P25	22	41	G1/8	27	M5	15	9	-	2.2	17.5	-	3.6	3.9	-	-	-	-	-	-	-
OSP-P32	25.5	52	G1/8	36	M6	15	12.2	10.5	-	20.5	-	-	-	-	-	-	-	-	-	15.2
OSP-P40	28	69	G1/8	54	M6	15	12	12	-	21	-	-	-	-	-	-	-	-	-	17
OSP-P50	33	87	G1/4	70	M6	15	14.5	14.5	-	-	-	-	-	-	-	-	-	-	-	22
OSP-P63	38	106	G3/8	78	M8	21	16.5	13.5	-	30	-	-	-	-	-	-	-	-	-	25
OSP-P80	47	132	G1/2	96	M10	25	22	17	-	37.5	-	-	-	-	-	-	-	-	-	34.5

Rodless Pneumatic Cylinders
OSP-P Series
P1X Series
GDL Series
2002/P120 Series
P55 Electronic & Reed Sensors
Accessories
Part Number Index
Safety Guide, Offer of Sale



For inventory, lead times, and kit lookup, visit www.pdnplu.com

Rodless Pneumatic Cylinders
OSP-P Series
P1X Series
GDL Series
2002/P120 Series
P55 Electronic & Reed Sensors
Accessories
Part Number Index
Safety Guide, Offer of Sale

Integrated 3/2 Way Valves VOE Series OSP-P25, P32, P40 and P50

For optimal control of the OSP-P cylinder, 3/2 way valves integrated into the cylinder's end caps can be used as a compact and complete solution.

They allow for easy positioning of the cylinder, smooth operation at the lowest speeds and fast response, making them ideally suited for the direct control of production and automation processes.

Characteristics:

- Complete compact solution
- Various connection possibilities:
 Free choice of air connection with rotating end caps with VOE valves, Air connection can be rotated 4 x 90°, Solenoid can be rotated 4 x 90°, Pilot Valve can be rotated 180°
- High piston velocities can be achieved with max. 3 exhaust ports
- Minimal installation requirements
- Requires just one air connection per valve
- Optimal control of the OSP-P cylinder
- Excellent positioning characteristics
- Integrated operation indicator
- Integrated exhaust throttle valve
- Manual override - indexed
- Adjustable end cushioning
- Easily retrofitted – please note the increase in the overall length of the cylinder!

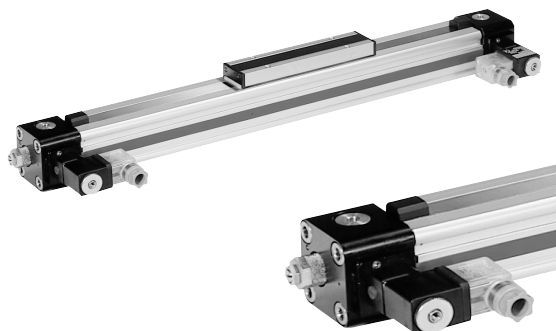

Operating information

Operating pressure:	116 PSIG (8 bar)
Temperature range:	-14°F to 122°F (10°C to 50°C)
Filtration requirements:	Filtered, nonlubricated compressed air

Specifications

• Characteristics	3/2 Way Valves with spring return electrical
• Actuation	P → A open, R closed
• Basic position	
• Type	Poppet valve, non overlapping
• Mounting	integrated in end cap
• Installation	in any position
• Port size	G 1/8 VOE-25 G 1/4 VOE-32 G 3/8 VOE-40 G 3/8 VOE-50
• Temperature	-10°C to 50°C *
• Operating pressure	2-8 bar
• Nominal voltage	24 V DC / 230 V AC, 50 Hz
• Power consumption	2,5 W / 6 VA
• Duty cycle	100%
• Electrical Protection	IP65 DIN 40050

* Other temperature ranges on request

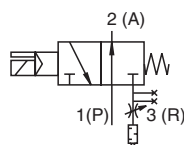

VOE-25 / VOE-32

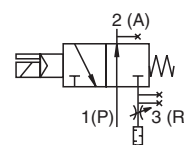

VOE-40 / VOE-50



For inventory, lead times, and kit lookup, visit www.pdnplu.com

Dimensions VOE Valves OSP-P25 and P32

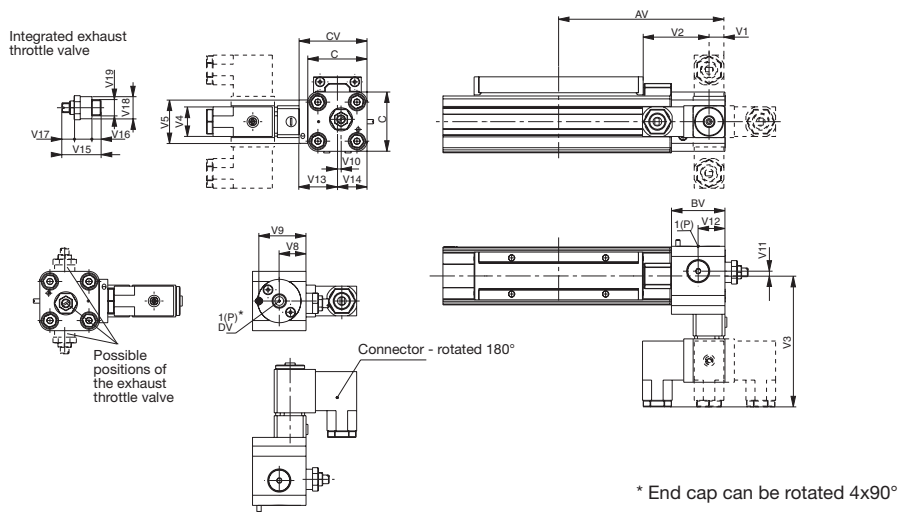

Dimension (mm)

Series	AV	BV	C	CV	DV	V1	V2	V3	V4	V5	V8	V9	V10	V11	V12	V13	V14	V15	V16	V17	V18	V19
OSP-P25	115	37	41	47	G1/8	11	46	90.5	22	30	18.5	32.5	2.5	3.3	18.5	26.5	20.5	24	5	4	14	G1/8
OSP-P32	139	39.5	52	58	G1/4	20.5	46	96	22	32	20.5	34.7	6	5	20.5	32	26	32	7.5	6	18	G1/4

Dimensions VOE Valves OSP-P40 and P50

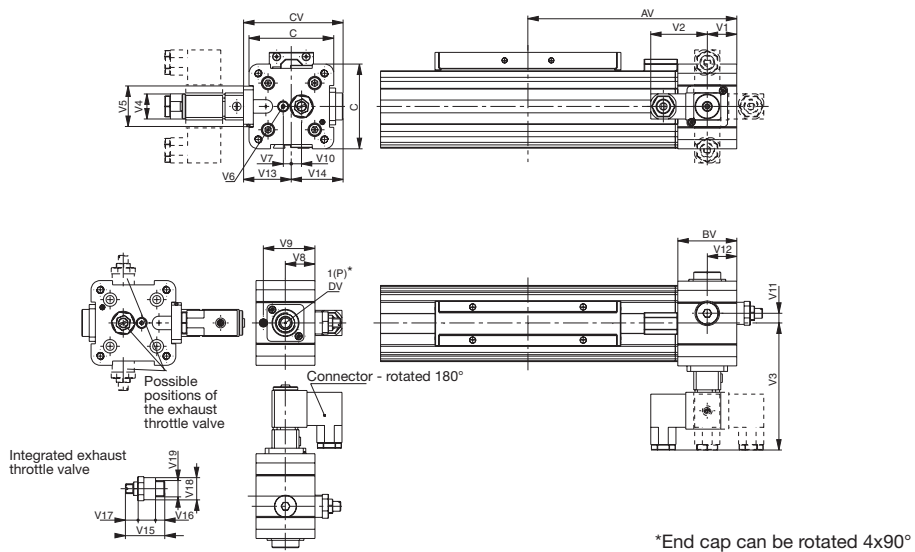

Dimension (mm)

Series	AV	BV	C	CV	DV	V1	V2	V3	V4	V5	V6	V7	V8	V9	V10	V11	V12	V13	V14	V15	V16	V17	V18	V19
OSP-P40	170	48	69	81	G3/8	24	46	103	22	33	M5	6.7	24	42	8.3	8.3	24	39	42	32	7.5	6	18	G1/4
OSP-P50	190	48	87	82	G3/8	24	46	102	22	33	M5	4.5	24	42	12.2	12.2	24	38	44	32	7.5	6	18	G1/4

Rodless Pneumatic Cylinders

OSP-P Series

P1X Series

GDL Series

2002/P120 Series

P55 Electronic & Reed Sensors

Accessories

Part Number Index

Safety Guide, Offer of Sale



For inventory, lead times, and kit lookup, visit www.pdnplu.com

Rodless Pneumatic Cylinders
OSP-P Series
P1X Series
GDL Series
2002/P120 Series
P55 Electronic & Reed Sensors
Accessories
Part Number Index
Safety Guide, Offer of Sale

Active Brake

Series AB 25 to 80 for linear drive

- Series OSP-P
- Can be used with Sensoflex

Features:

- Actuated by pressurization
- Released by spring actuation
- Completely stainless version
- Holds position, even under changing load conditions

For further technical data, please refer to the data sheets for linear drives OSP-P (page 77)

Note:

For combinations Active Brake AB + SFI-plus + Magnetic Switch contact our technical department please.

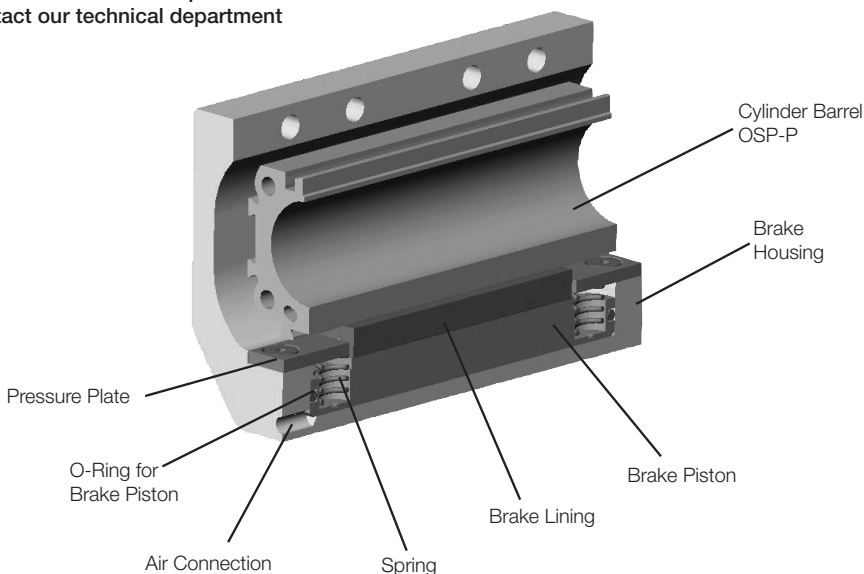

Forces and Weights

Series	For Linear Drive	Max. Braking Force (N) †	Brake Pad Way (mm)	Mass (kg)			Part Number Active Brake (includes carriage)
				Linear Drive with Brake			
				0 mm Stroke	Increase per 100mm Stroke	Brake*	
AB 25	OSP-P25	350	2.5	1.0	0.197	0.35	20806FIL
AB 32	OSP-P32	590	2.5	2.02	0.354	0.58	20807FIL
AB 40	OSP-P40	900	2.5	2.83	0.415	0.88	20808FIL
AB 50	OSP-P50	1400	2.5	5.03	0.566	1.50	20809FIL
AB 63	OSP-P63	2170	3.0	9.45	0.925	3.04	20810FIL
AB 80	OSP-P80	4000	3.0	18.28	1.262	5.82	20811FIL

† – at 6 bar both chambers pressurized with 6 bar Braking surface dry
 – oil on the braking surface will reduce the braking force

*** Please Note:**

The mass of the brake has to be added to the total moving mass when using the cushioning diagram.



For inventory, lead times, and kit lookup, visit www.pdnplu.com

Series OSP-P25 and P32 with Active Brake AB

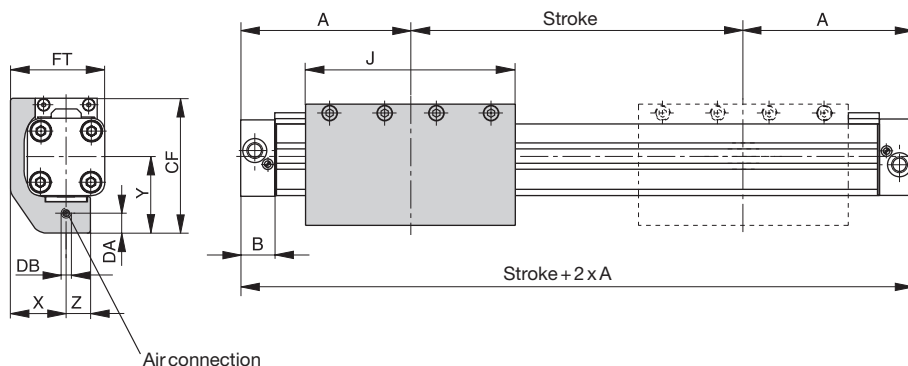

Series OSP-P40, P50, P63, P80 with Active Brake AB

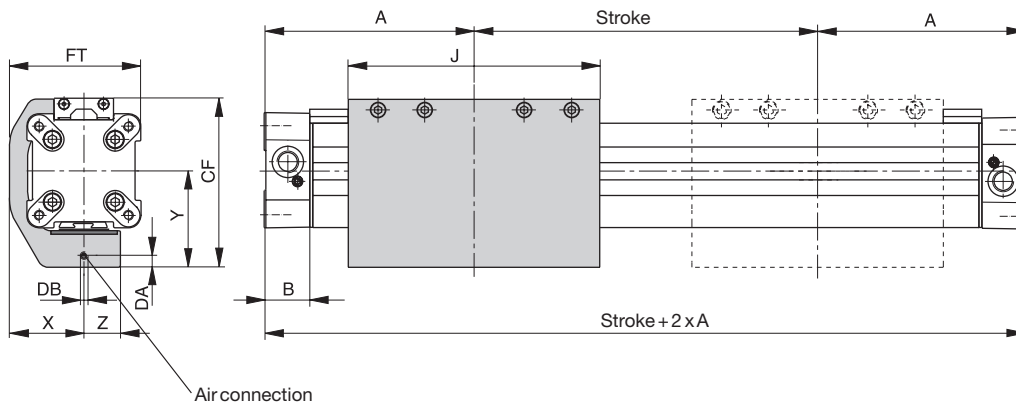

Dimension (mm)

Series	A	B	J	X	Y	Z	CF	DA	DB	FT
AB 25	100	22	117	29.5	43	13	74	4	M5	50
AB 32	125	25.5	151.4	36	50	15	88	4	M5	62
AB 40	150	28	151.4	45	58	22	102	7	M5	79.5
AB 50	175	33	200	54	69.5	23	118.5	7.5	M5	97.5
AB 63	215	38	256	67	88	28	151	9	G1/8	120
AB 80	260	47	348	83	105	32	185	10	G1/8	149

Rodless Pneumatic Cylinders
OSP-P Series
P1X Series
GDL Series
2002/P120 Series
P5S Electronic & Reed Sensors
Accessories
Part Number Index
Safety Guide, Offer of Sale



For inventory, lead times, and kit lookup, visit www.pdnplu.com

Rodless Pneumatic Cylinders
 OSP-P Series
 P1X Series
 GDL Series
 2002/P120 Series
 P55 Electronic & Reed Sensors
 Accessories
 Part Number Index
 Safety Guide, Offer of Sale

End Cap Mountings

On the end-face of each cylinder end cap there are four threaded holes for mounting the cylinder. The hole layout is square, so that the mounting can be fitted to the bottom, top or either side.

Series OSP – P25 and P32 with Active Brake AB: Type A3

Material:

Galvanized steel

The mountings are supplied in pairs.

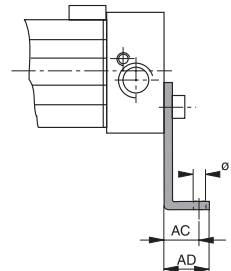
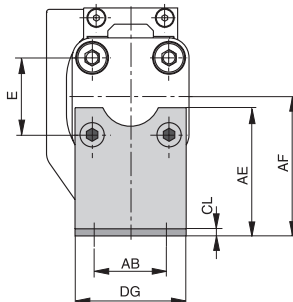

Series OSP – P40 , P50, P63, P80 with Active Brake AB: Type C3

Material:

Anodized aluminum

The mountings are supplied in pairs.

Stainless steel version on request.

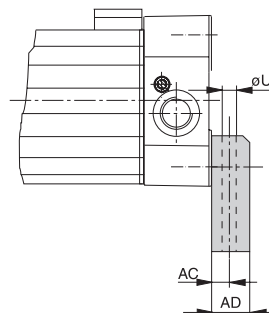
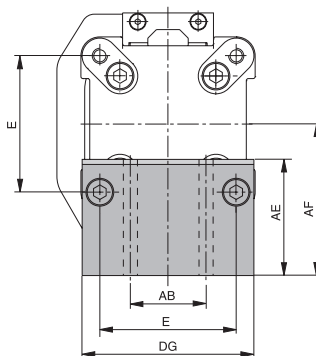

Dimension (mm)

Series	E	øU	AB	AC	AD	AE	AF	CL	DG	Part Number	
										Type A3	Type C3
AB 25	27	5.8	27	16	22	45	49	2.5	39	2060FIL	-
AB 32	36	6.6	36	18	26	42	52	3	50	3060FIL	-
AB 40	54	9	30	12.5	24	46	60	-	68	-	20339FIL
AB 50	70	9	40	12.5	24	54	72	-	86	-	20350FIL
AB 63	78	11	48	15	30	76	93	-	104	-	20821FIL
AB 80	96	14	60	17.5	35	88	110	-	130	-	20822FIL



For inventory, lead times, and kit lookup, visit www.pdnplu.com

Mid-Section Supports

Mid-section supports are required from a certain stroke length to prevent excessive deflection and vibration of the linear drive.

The diagrams show the maximum permissible unsupported length in relation to loading. Deflection of 0.5mm max. between supports is permissible.

The Mid-Section supports are attached to the dovetail rails, and can take axial loads.

Note to Type E3:

Mid-Section supports can only be mounted opposite of the brake housing.

Stainless steel version available on request.

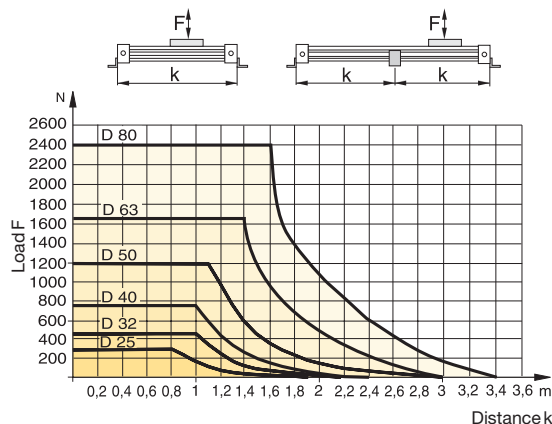

Series OSP-P25 to P80 with Active Brake AB: Type E3

(Mounting from above / below with through-bolt)

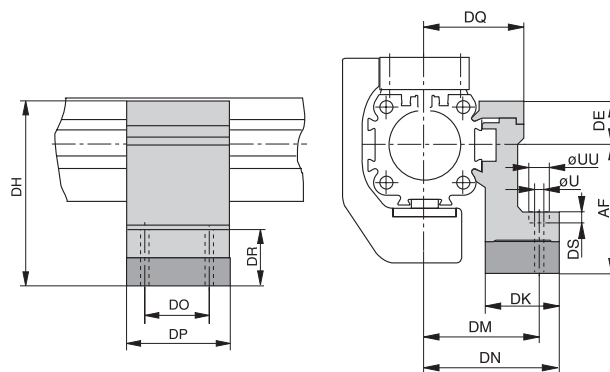

Dimension (mm)

Series	U	UU	AF	DE	DH	DK	DM	DN	DO	DP	DQ	DR	DS	Type E3 Part Number
AB 25	5.5	10	49	16	65	26	40	47.5	36	50	34.5	35	5.7	20353FIL
AB 32	5.5	10	52	16	68	27	46	54.5	36	50	40.5	32	5.7	20356FIL
AB 40	7	-	60	23	83	34	53	60	45	60	45	32	-	20359FIL
AB 50	7	-	72	23	95	34	59	67	45	60	52	31	-	20362FIL
AB 63	9	-	93	34	127	44	73	83	45	65	63	48	-	20453FIL
AB 80	11	-	110	39.5	149.5	63	97	112	55	80	81	53	-	20819FIL

Rodless Pneumatic Cylinders
OSP-P Series
P1X Series
GDL Series
2002/P120 Series
P55 Electronic & Reed Sensors
Accessories
Part Number Index
Safety Guide, Offer of Sale



For inventory, lead times, and kit lookup, visit www.pdnplu.com

Clevis Mount ϕ 16 to 80mm

For Linear-drive

- Series OSP-P

When external guides are used, parallelism deviations can lead to mechanical strain on the piston. This can be avoided by the use of a clevis mounting.

In the drive direction, the mounting has very little play.

Freedom of movement is provided as follows:

- Tilting in direction of movement
- Vertical compensation
- Tilting sideways
- Horizontal compensation

A stainless steel version is also available.

OSP

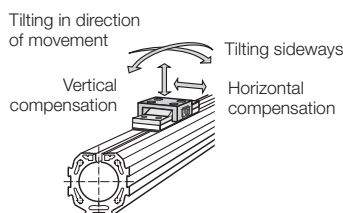
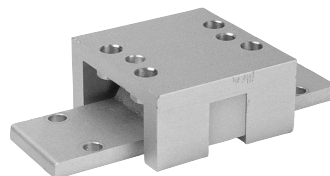

Please note:
When using additional inversion mountings, take into account the dimensions in page 28.

Series OSP-P16 to 32

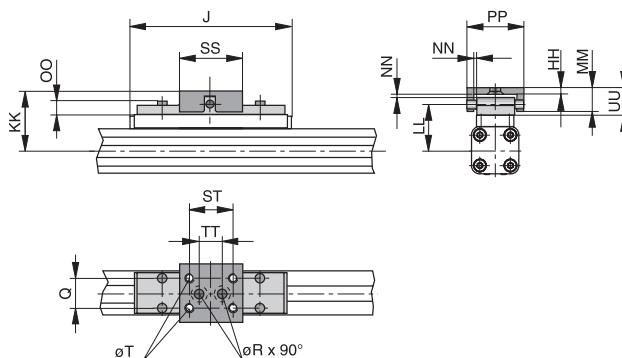

Series OSP-P40 to 80

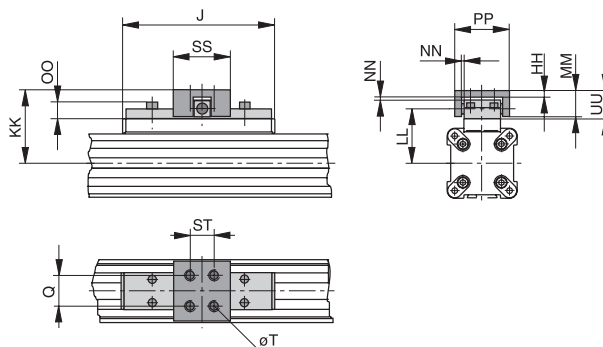

Dimension (mm)

Series	J	Q	T	ϕ R	HH	KK	LL	MM	NN*	OO	PP	SS	ST	TT	UU	Part Number	
																Standard	Stainless
OSP-P16	69	10	M4	4.5	3	34	26.6	10	1	8.5	26	28	20	10	11	20462FIL	20463FIL
OSP-P25	117	16	M5	5.5	3.5	52	39	19	2	9	38	40	30	16	21	20005FIL	20092FIL
OSP-P32	152	25	M6	6.6	6	68	50	28	2	13	62	60	46	40	30	20096FIL	20094FIL
OSP-P40	152	25	M6	-	6	74	56	28	2	13	62	60	46	-	30	20024FIL	20093FIL
OSP-P50	200	25	M6	-	6	79	61	28	2	13	62	60	46	-	30	20097FIL	20095FIL
OSP-P63	256	37	M8	-	8	100	76	34	3	17	80	80	65	-	37	20466FIL	20467FIL
OSP-P80	348	38	M10	-	8	122	96	42	3	16	88	90	70	-	42	20477FIL	20478FIL

* Dimension NN gives the possible plus and minus play in horizontal and vertical movement, which also makes tilting sideways possible.



For inventory, lead times, and kit lookup, visit www.pdnplu.com

Rodless Pneumatic Cylinders
OSP-P Series
P1X Series
GDL Series
2002/P120 Series
P55 Electronic & Reed Sensors
Accessories
Part Number Index
Safety Guide, Offer of Sale

Rodless Pneumatic Cylinders
OSP-P Series
P1X Series
GDL Series
2002/P120 Series
P55 Electronic & Reed Sensors
Accessories
Part Number Index
Safety Guide, Offer of Sale

Inversion Mount ø 16 to 80mm

For Linear-drive

- Series OSP-P

OSP



In dirty environments, or where there are special space problems, inversion of the cylinder is recommended.

The inversion bracket transfers the driving force to the opposite side of the cylinder. The size and position of the mounting holes are the same as on the standard cylinder.

Please note:

Other components of the OSP system such as mid-section supports, magnetic switches and the external air passage for the P16, can still be mounted on the free side of the cylinder.

When combining single end porting with inversion mountings,

RS magnetic switches can only be mounted directly opposite to the external air-supply profile.

Important Note:

May be used in combination with Clevis Mounting, reference dimensions in pages G32-G33.

Series OSP-P16 to 32

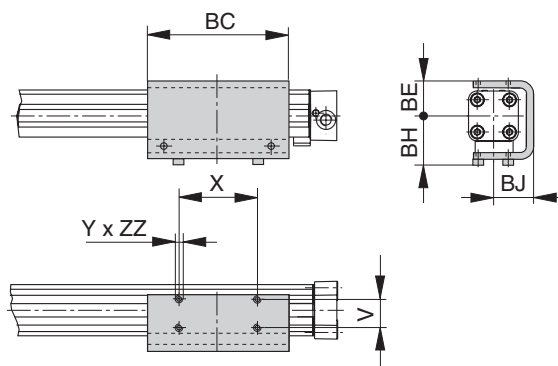

Series OSP-P40 to 80

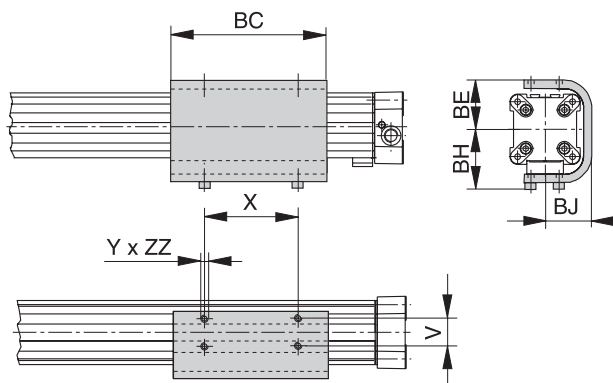

Dimension (mm)

Series	V	X	Y	BC	BE	BH	BJ	ZZ	Part Number
OSP-P16	16.5	36	M4	69	23	33	25	4	20446FIL
OSP-P25	25	65	M5	117	31	44	33.5	6	20037FIL
OSP-P32	27	90	M6	150	38	52	39.5	6	20161FIL
OSP-P40	27	90	M6	150	46	60	45	8	20039FIL
OSP-P50	27	110	M6	200	55	65	52	8	20166FIL
OSP-P63	34	140	M8	255	68	83.5	64	10	20459FIL
OSP-P80	36	190	M10	347	88	107.5	82	15	20490FIL



For inventory, lead times, and kit lookup, visit www.pdnplu.com

End Cap Mounting \varnothing 10 to 80mm

For Linear-drive

- Series OSP-P

OSP

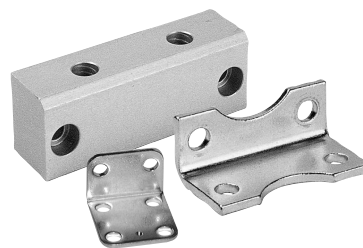

On the end-face of each end cap there are four threaded holes for mounting the actuator.

The hole layout is square, so that the mounting can be fitted to the bottom, top or either side, regardless of the position chosen for the air connection.

Material:

Series OSP-P10 – P32: Galvanized steel.

Series OSP-P40 – P80: Anodized aluminum.

The mountings are supplied in pairs.

Series OSP-P10: Type A1

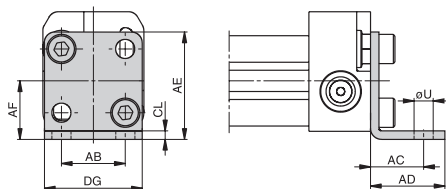

Series OSP-P40 to 80: Type C1

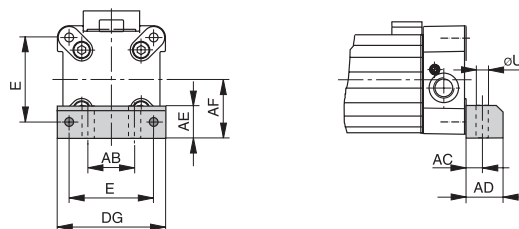

Series OSP-P16 to 32: Type A1

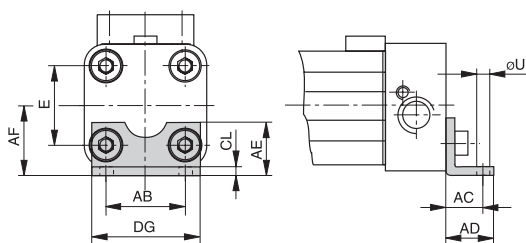

Dimension (mm)

Series	E	ØU	AB	AC	AD	AE	AF	CL	DG	Part Number (pair)	
										Type A1	Type C1
OSP-P10	-	3.6	12	10	14	20.2	11	1.6	18.4	0240	-
OSP-P16	18	3.6	18	10	14	12.5	15	1.6	26	20408FIL	-
OSP-P25	27	5.8	27	16	22	18	22	2.5	39	2010	-
OSP-P32	36	6.6	36	18	26	20	30	3	50	3010	-
OSP-P40	54	9	30	12.5	24	24	38	-	68	-	4010FIL
OSP-P50	70	9	40	12.5	24	30	48	-	86	-	5010FIL
OSP-P63	78	11	48	15	30	40	57	-	104	-	6010FIL
OSP-P80	96	14	60	17.5	35	50	72	-	130	-	8010FIL



For inventory, lead times, and kit lookup, visit www.pdnplu.com

Rodless Pneumatic Cylinders
OSP-P Series
P1X Series
GDL Series
2002/P120 Series
P55 Electronic & Reed Sensors
Accessories
Part Number Index
Safety Guide, Offer of Sale

Rodless Pneumatic Cylinders
OSP-P Series
P1X Series
GDL Series
2002/P120 Series
P55 Electronic & Reed Sensors
Accessories
Part Number Index
Safety Guide, Offer of Sale

Mid-Section Support ø 10 to 80mm

For Linear-drive

- Series OSP-P

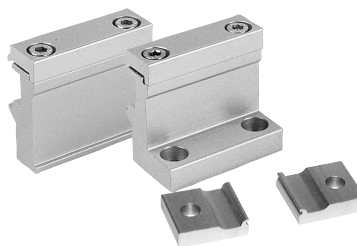

Note on Types E1 and D1 (P16 – P80):

The mid-section support can also be mounted on the underside of the actuator, in which case its distance from the center of the actuator is different.

Stainless steel version on demand.

Series OSP-10, Type E1

(Mounting from above / below using a cap screw)

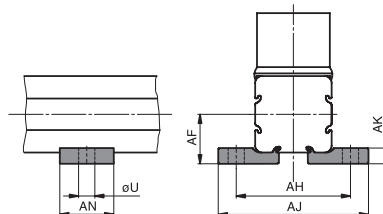

Series OSP-P16 to P80: Type E1

(Mounting from above / below using a cap screw)

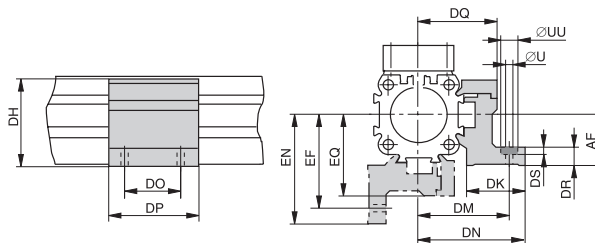

Series OSP-16 to 80, Type D1

(Mountings from below with 2 screws)

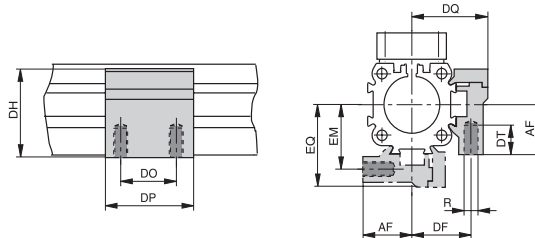

Dimension (mm)

Series	U	AF	AH	AJ	AK	AN	Part Number	
							Type E1	Type D1
OSP-P10	3.6	11	25.4	33.4	3.5	12	0250	-

Series	R	U	UU	AF	DF	DH	DK	DM	DN	DO	DP	DQ	DR	DS	DT	EF	EM	EN	EQ	Part Number	
																				Type E1	Type D1
OSP-P16	M3	3.4	6	15	20	29.2	24	32	36.4	18	30	27	6	3.4	6.5	32	20	36.4	27	20435FIL	20434FIL
OSP-P25	M5	5.5	10	22	27	38	26	40	47.5	36	50	34.5	8	5.7	10	41.5	28.5	49	36	20009FIL	20008FIL
OSP-P32	M5	5.5	10	30	33	46	27	46	54.5	36	50	40.5	10	5.7	10	48.5	35.5	57	43	20158FIL	20157FIL
OSP-P40	M6	7	-	38	35	61	34	53	60	45	60	45	10	-	11	56	38	63	48	20028FIL	20027FIL
OSP-P50	M6	7	-	48	40	71	34	59	67	45	60	52	10	-	11	64	45	72	57	20163FIL	20162FIL
OSP-P63	M8	9	-	57	47.5	91	44	73	83	45	65	63	12	-	16	79	53.5	89	69	20452FIL	20451FIL
OSP-P80	M10	11	-	72	60	111.5	63	97	112	55	80	81	15	-	25	103	66	118	87	20482FIL	20480FIL



For inventory, lead times, and kit lookup, visit www.pdnplu.com

Adaptor Profile \varnothing 16 to 50mm

For Linear-drive

- Series OSP-P

OSP

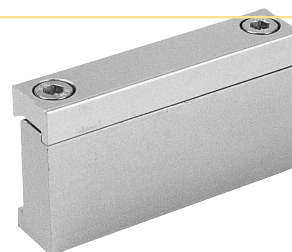

Adaptor Profile OSP

- A universal attachment for mounting of valves etc.
- Solid material

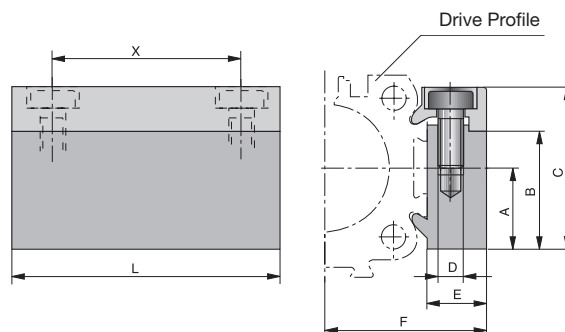

Dimension (mm)

Series	A	B	C	D	E	F	L	X	Part Number	
									Standard	Stainless
OSP-P16	14	20.5	28	M3	12	27	50	38	20432FIL	20438FIL
OSP-P25	16	23	32	M5	10.5	30.5	50	36	20006FIL	20186FIL
OSP-P32	16	23	32	M5	10.5	36.5	50	36	20006FIL	20186FIL
OSP-P40	20	33	43	M6	14	45	80	65	20025FIL	20267FIL
OSP-P50	20	33	43	M6	14	52	80	65	20025FIL	20267FIL

Rodless Pneumatic Cylinders
OSP-P Series
P1X Series
GDL Series
2002/P120 Series
P5S Electronic & Reed Sensors
Accessories
Part Number Index
Safety Guide, Offer of Sale



For inventory, lead times, and kit lookup, visit www.pdnplu.com

Rodless Pneumatic Cylinders

OSP-P Series

P1X Series

GDL Series

2002/P120 Series

P55 Electronic & Reed Sensors

Accessories

Part Number Index

Safety Guide, Offer of Sale

T-Slot Profile \varnothing 16 to 50mm

For Linear-drive

- Series OSP-P

OSP

T-Slot Profile OSP

- A universal attachment for mounting with standard T-Nuts

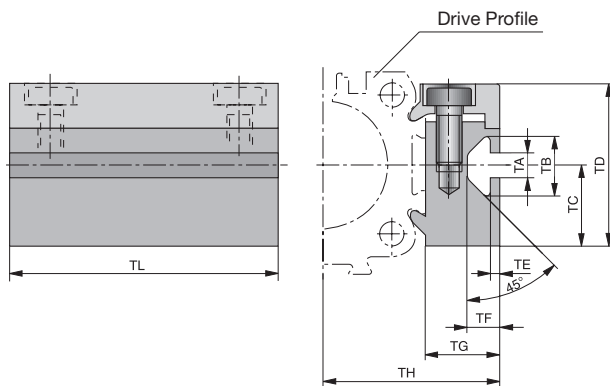
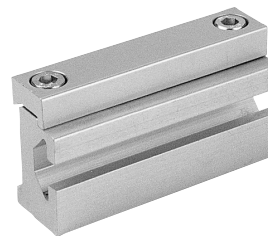

Dimension (mm)

Series	TA	TB	TC	TD	TE	TF	TG	TH	TL	Part Number	
										Standard	Stainless
OSP-P16	5	11.5	14	28	1.8	6.4	12	27	50	20433FIL	20439FIL
OSP-P25	5	11.5	16	32	1.8	6.4	14.5	34.5	50	20007FIL	20187FIL
OSP-P32	5	11.5	16	32	1.8	6.4	14.5	40.5	50	20007FIL	20187FIL
OSP-P40	8.2	20	20	43	4.5	12.3	20	51	80	20026FIL	20268FIL
OSP-P50	8.2	20	20	43	4.5	12.3	20	58	80	20026FIL	20268FIL



For inventory, lead times, and kit lookup, visit www.pdnplu.com

Connection Profile \varnothing 16 to 50mm

For combining

- Series OSP-P with system profiles
- Series OSP-P with Series OSP-P

OSP

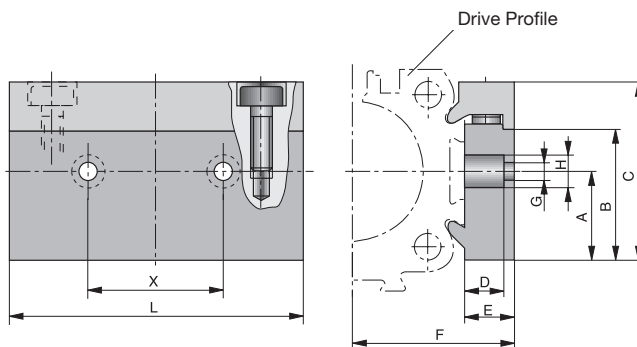

Dimension (mm)

Cylinder Series	For Mounting on the Carrier of	A	B	C	D	E	F	G	H	L	X	Part Number
OSP-P16	OSP25	14	20.5	28	8.5	12	27	5.5	10	50	25	20849FIL
OSP-P25	OSP32-50	16	23	32	8.5	10.5	30.5	6.6	11	60	27	20850FIL
OSP-P32	OSP32-50	16	23	32	8.5	10.5	36.5	6.6	11	60	27	20850FIL
OSP-P40	OSP32-50	20	33	43	8	14	45	6.6	11	60	27	20851FIL
OSP-P50	OSP32-50	20	33	43	8	14	52	6.6	11	60	27	20851FIL

Possible Combinations

Combination of Series OSP-P with system profiles



Combination of Series OSP-P with Series OSP-P

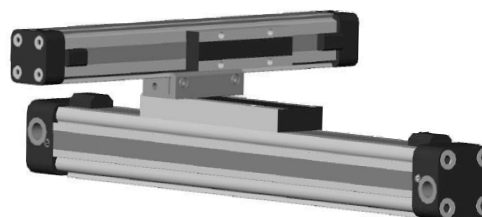

For inventory, lead times, and kit lookup, visit www.pdnplu.com

Rodless Pneumatic Cylinders
OSP-P Series
P1X Series
GDL Series
2002/P120 Series
P5S Electronic & Reed Sensors
Accessories
Part Number Index
Safety Guide, Offer of Sale

Features
Clean Room Cylinder ø 16 – 32 mm Rodless Cylinder certified to DIN EN ISO 14644-1
Standard Features:

- Double-acting with adjustable end cushioning
- With magnetic piston for position sensing
- Clean Room classification
ISO Class 4 at $v_m = 0.14$ m/s
ISO Class 5 at $v_m = 0.5$ m/s
- Suitable for smooth slow speed operation up to $v_{min} = 0.005$ m/s
- Optional stroke length up to 1200mm (longer strokes on request)
- Low maintenance
- Compact design with equal force and velocity in both directions
- Aluminum piston with bearing rings to support high direct and cantilever loads
- Stainless steel screws

Optional Features:

- Slow speed lubrication
- Fluorocarbon (FKM) seals

Specifications

- Type: Rodless cylinder
- Series: OSP-P
- Stroke length: 5.5m (216 inches)
- System: Double-acting, with cushioning, position sensing capability
- Mounting: See drawings
- Air connection: Threaded
- Weight (mass): See table
- Installation: In any position
- Lubrication: Prelubricated at the factory (additional oil mist lubrication not required)
- Option: special slow speed grease

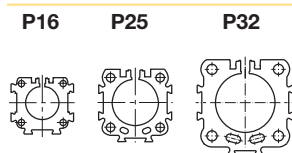
Size Comparison

Operating information

Operating pressure:	116 PSIG (8 bar)
Temperature range:	14°F to 176°F (10°C to 80°C)
Filtration requirements:	Filtered, nonlubricated compressed air

Material specifications

Cylinder profile	Anodized aluminum
Carrier (piston)	Anodized aluminum
End caps	Aluminum, lacquered
Sealing bands	Corrosion resistant steel
Seals	NBR (Option: Fluorocarbon)
Screws	Stainless steel
Covers	Anodized aluminum
Guide plate	Plastic

Weight (mass) kg

Cylinder Series (Basic cylinder)	Weight (Mass) kg	
	at 0mm Stroke	Per 100mm Stroke
OSP-P16	0.22	0.1
OSP-P25	0.65	0.197

 For inventory, lead times, and kit lookup, visit www.pdnplu.com

Rodless Pneumatic Cylinders
OSP-P Series
P1X Series
GDL Series
2002/P120 Series
P5S Electronic & Reed Sensors
Accessories
Part Number Index
Safety Guide, Offer of Sale

Certification

Based on the Parker's rodless cylinder, proven in world wide markets, Parker now offers the only rodless cylinder on the market with a certification from IPA Institute for the clean room specification according to DIN EN ISO 14644-1.

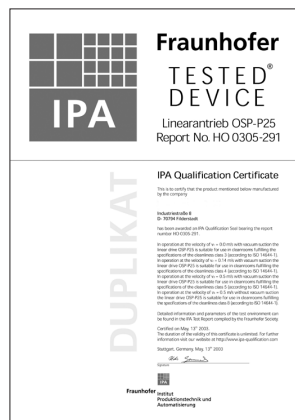

Function

The clean room cylinders of the OSP-P combines the efficiency of the slot seal system with vacuum protection against progressive wear and contamination from the sliding components. A partial vacuum drawn between inner and outer sealing bands prevents emission into the clean room. To achieve the necessary vacuum a suction flow of ca. 4 m³/h is required.

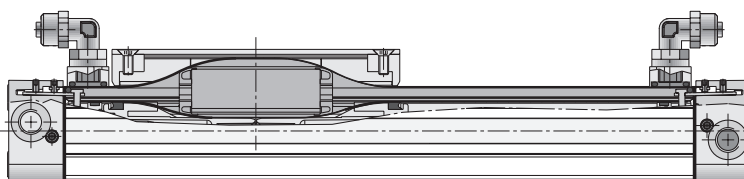

Loads, Forces and Moments

Cylinder Series (mm Ø)	Effective Force at 6 bar (N)	Max. Moment			Max. Load Fz (N)	Cushion Length (mm)
		Mx (Nm)	My (Nm)	Mz (Nm)		
OSP-P16	78	0.45	4	0.5	120	11
OSP-P25	250	1.5	15	3.0	300	17
OSP-P32	420	3.0	30	5.0	450	20

Load and moment data are based on speeds $v \leq 0.2$ m/s. The adjacent table shows the maximum values for light, shock-free operation which must not be exceeded even in dynamic operation.

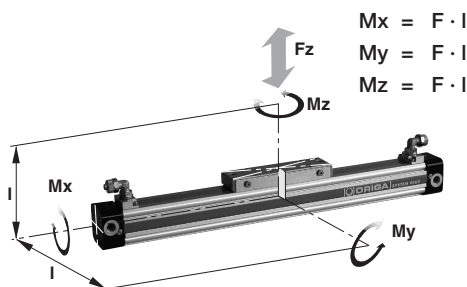

For inventory, lead times, and kit lookup, visit www.pdnplu.com

Clean Room Cylinders ø 16-32 mm

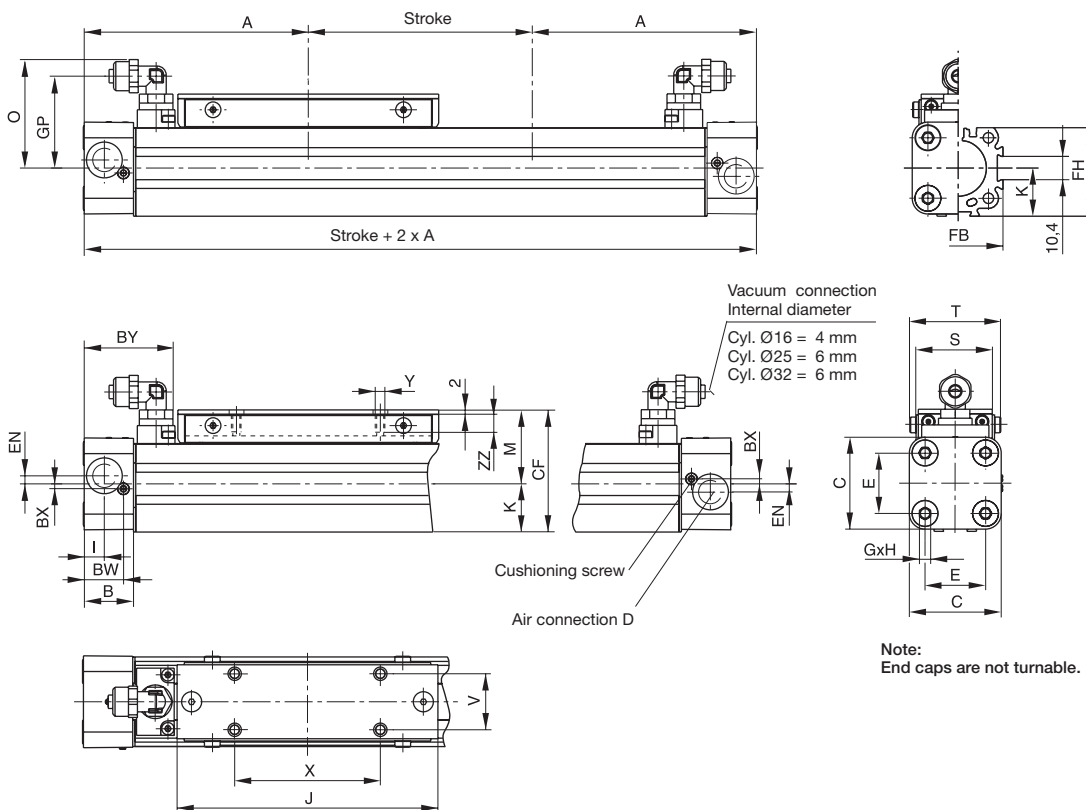

Dimension (mm)

Series	A	B	C	D	E	G	H	I	J	K	M	O	S
OSP-P16	65	14	30	M5	18	M3	9	5.5	69	15	25	31	24
OSP-P25	100	22	41	G1/8	27	M5	15	9	117	21.5	33	48.5	35
OSP-P32	125	25.5	52	G1/4	36	M6	15	11.5	152	28.5	40	53.6	38

Series	T	V	X	Y	BW	BX	BY	CF	EN	FB	FH	GP	ZZ
OSP-P16	29.6	16.5	36	M4	10.8	1.8	28.5	40	3	30	27.2	25.7	7
OSP-P25	40.6	25	65	M5	17.5	2.2	40.5	54.5	3.6	40	39.5	41	8
OSP-P32	45	27	90	M6	20.5	2.5	47.1	68.5	5.5	52	51.7	46.2	10

Rodless Pneumatic Cylinders
OSP-P Series
P1X Series
GDL Series
2002/P120 Series
P55 Electronic & Reed Sensors
Accessories
Part Number Index
Safety Guide, Offer of Sale



For inventory, lead times, and kit lookup, visit www.pdnplu.com

Features
Synchronized Bi-Parting movements Type OSP-P40-SL-BP for Rodless Cylinder ø 40mm
Standard Features:

- Accurate bi-parting movement through toothed belt synchronization
- Optimum slow speed performance
- Increased action force
- Anodized aluminum guide rail with prism-form slideway arrangement
- Adjustable polymer slide units
- Combined sealing system with polymer and felt elements to remove dirt and lubricate the slideway
- Integrated grease nipples for guide lubrication

Applications:

- Opening and closing operations
- Gripping of workpieces – outside
- Gripping of hollow workpieces – inside
- Gripping underneath larger objects
- Clamping force adjustable via pressure regulator

Specifications

- Type Rodless cylinder for synchronized bi-parting movements
- Series OSP-P
- System Double-acting, with end cushioning, for contactless position sensing
- Guide Slideline SL40
- Synchronization Toothed belt
- Mounting See drawing
- Weight (mass) See table
- Lubrication Special slow speed grease (additional oil mist lubrication not required)
- Cushioning middle position Elastic buffer
- Maximum speed 0.2 m/s V_{max}
- Maximum stroke of each stroke 500 mm
- Maximum mass per guide carrier
 - lateral moment 25 Nm $M_{X_{max}}$
 - axial moment 46 Nm $M_{Y_{max}}$
 - rotating moment 46 Nm $M_{Z_{max}}$
- Option: special slow speed grease

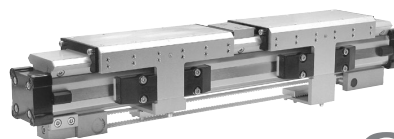
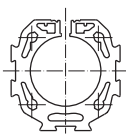
Size
P40

OSP
Operating information

Operating pressure:	116 PSIG (8 bar)
Temperature range:	14°F to 140°F (-10°C to 60°C)
Filtration requirements:	Filtered, nonlubricated compressed air

Material specifications

Belt wheel	Aluminum
Toothed belt	Steel-corded polyurethane

Weight (mass) kg

Cylinder Series (Basic cylinder)	Weight (Mass) kg	
	at 0mm Stroke	per 100mm Stroke
OSP-P40-SL-BP	10.334	2.134

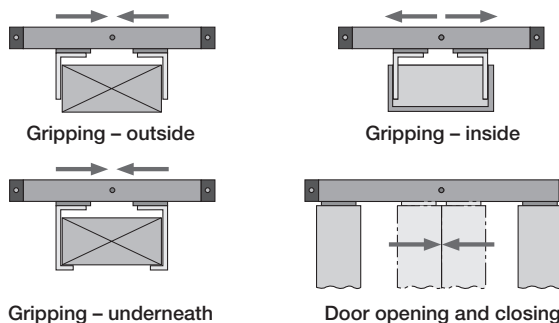
Applications

 For inventory, lead times, and kit lookup, visit www.pdnplu.com

Ordering information for OSP-P rodless Bi-Parting pneumatic series

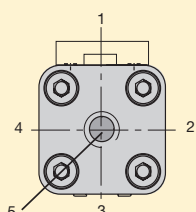
1-4	5-6	7	8	9	10	11	12-16	17	18	19	20	21	22	23	24	25
	Bore 40				Lubrication 0 Standard		Stroke† x x x x x 5 digits in whole millimeters (ex. 1100mm = 01100)		Cushions / Stops 0 Standard				Dovetail Cover 0 Standard X Without Cover Rail		Version 0 Standard	
		Piston Style N Bi-Parting		Seals 0 Standard					Piston Mounting 0 None			Additional Carriages 0 None				
					Hardware 0 Standard 1 Stainless Steel											
		Porting Configurations 0 Standard 1 End Face 3 Left Std Pos #2, Right Pos #5 4 Left Pos #5, Right Std Pos #2 6 Single End Porting at #5								Guides / Brakes 0 None						
							Endcap Position 0 Both Pos #2 1 Both Pos #3 2 Both Pos #4 3 Both Pos #1 4 Left #3 / Right #2 5 Left #4 / Right #2 6 Left #1 / Right #2 7 Left #2 / Right #3 8 Left #4 / Right #3 9 Left #1 / Right #3 A Left #2 / Right #4 B Left #3 / Right #4 C Left #1 / Right #4 D Left #2 / Right #1 E Left #3 / Right #1 F Left #4 / Right #1									
													Endcap Mounting 0 None A C2 B C3 C C4 Note: Comes in pairs			
														Switches ◊ 0 None 1 Normally Open Reed Switch 2 Normally Closed Reed Switch 3 Pnp Hall Sensor w/Extension Cables 4 Npn Hall Sensor w/Extension Cables ◊ Note: 2 switches will be supplied. For different quantity, please order as a separate line item.		



Note: Position #2 is the standard location.

† Reference Cylinder Stroke and Dead Length A, pages 16-17 for stroke consideration because of the use of two pistons.

Rodless Pneumatic Cylinders
OSP-P Series
P1X Series
GDL Series
2002/P120 Series
P55 Electronic & Reed Sensors
Accessories
Part Number Index
Safety Guide, Offer of Sale



For inventory, lead times, and kit lookup, visit www.pdnplu.com

Rodless Pneumatic Cylinders
OSP-P Series
P1X Series
GDL Series
2002/P120 Series
P55 Electronic & Reed Sensors
Accessories
Part Number Index
Safety Guide, Offer of Sale

Function:

The OSP-P40-SL-BP bidirectional linear drive is based on the OSP-P40 rodless pneumatic cylinder and adapted SLIDELINE SL40 polymer plain-bearing guides.

Two pistons in the cylinder bore are connected via yokes and carriers to the SLIDELINE guide carriers, which handle the forces and moments generated.

The bi-parting movements of the guide carriers are accurately synchronized by a recirculating toothed belt.

The two pistons are driven from the middle to the end positions via a common G1/4 air connection in the middle of the cylinder, and are driven from the end positions to the middle via an air connection in each end cap.

End position cushioning is provided by adjustable air cushioning in the end caps, and middle position cushioning by rubber buffers.

Dimensions (mm)

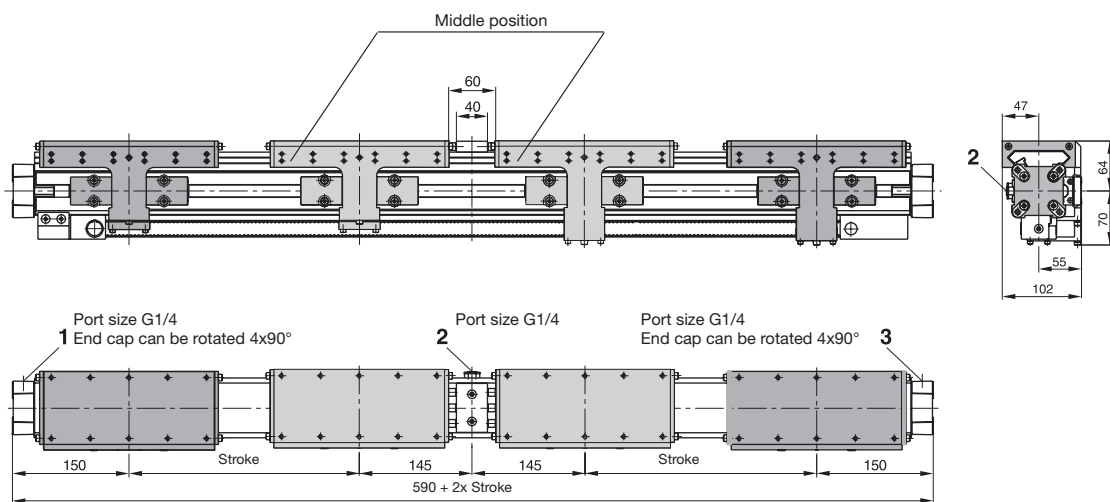

Air connections:

To drive the guide carriers to the middle position: pressurize ports 1 and 3.

To drive the guide carriers to the end positions: pressurize port 2.

For more dimensions see pages 18 and 19.



For inventory, lead times, and kit lookup, visit www.pdnplu.com

Linear Guides for OSP-P Series

OSP

Adaptive modular system

The OSP Series provides a comprehensive range of linear guides for the pneumatic OSP-P.

Advantages:

- Takes high loads and forces
- High precision
- Smooth operation
- Can be retrofitted
- Can be installed in any position

Series OSP-P - Standard

- Piston diameters 10 to 80mm



SLIDELINE

- The cost-effective plain bearing guide for medium loads.
- Active/ Passive Brake optional.
- Piston diameters 16 to 80mm

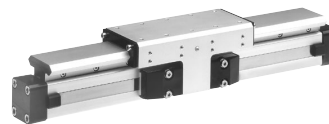

POWERSLIDE

- The roller guide for heavy loads and hard application conditions
- Piston diameters 16 to 50mm



PROLINE

- The compact aluminum roller guide for high loads and velocities.
- Active / Passive Brake optional.
- Piston diameters 16 to 50mm



STARLINE

- Recirculating ball bearing guide for very high loads and precision
- Piston diameters 16 to 50mm



KF GUIDE

- Recirculating ball bearing guide for highest loads and precision.
- Correspond to FESTO dimensions (Type DGPL-KF)
- Piston diameters 16 to 50mm

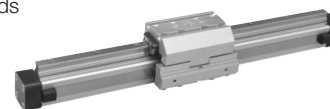

HD HEAVY DUTY GUIDE

- The ball bushing guide for the heavy loads and greatest accuracy.
- Piston diameters 25 to 50mm

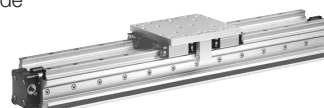

Rodless Pneumatic Cylinders

OSP-P Series

P1X Series

GDL Series

2002/P120 Series

P5S Electronic & Reed Sensors

Accessories

Part Number Index

Safety Guide, Offer of Sale



For inventory, lead times, and kit lookup, visit www.pdnplu.com

Rodless Pneumatic Cylinders
OSP-P Series
P1X Series
GDL Series
2002/P120 Series
P55 Electronic & Reed Sensors
Accessories
Part Number Index
Safety Guide, Offer of Sale

Application Example - Vertical Application

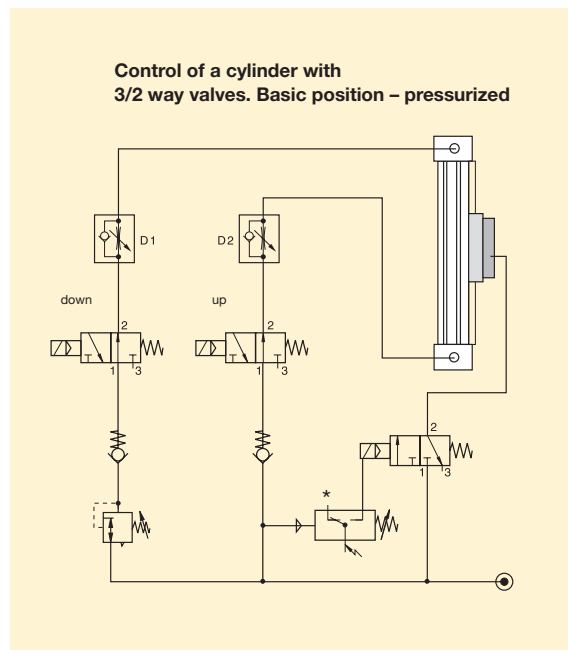
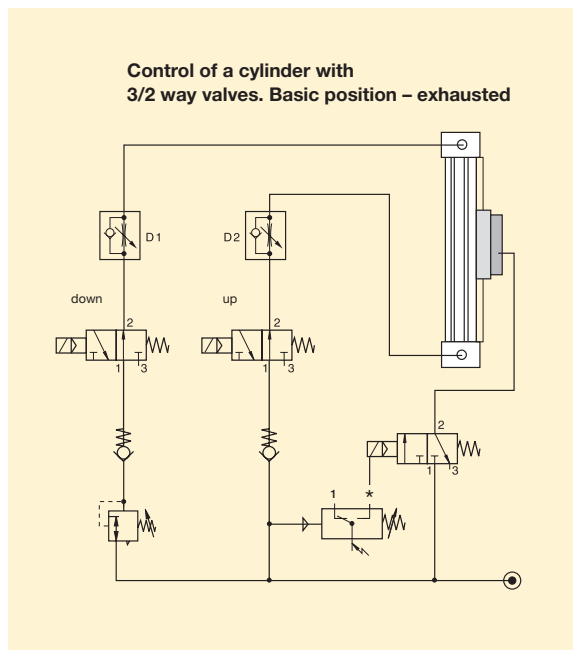

Control Examples

Under normal operating circumstances the pressure switch is closed and the air flows through the 3/2 way solenoid valves from port 1 to 2, thus lifting the brake from the rail (operating condition).

The brake is pressurized by means of a 3/2 way valve in combination with a pressure switch. When there is a pressure loss, the brake is actuated by the pressure switch.

When the air pressure is restored to both cylinder chambers, the brake is lifted and the linear drive can be moved again.

The speed regulating valves D1 and D2 control the speed of the linear drive, and have no influence on the brake. The two non-return valves give the system a higher stability.

The pressure regulating valve is used to compensate for the downward force in this vertical application.

Please note:



Before the brake is lifted, make sure that both air chambers of the linear drive are pressurized.

Small diameter tubing, fittings and valves with a nominal diameter, and tubing that is too long all change the reaction time of the brake!

***Tip:**

The pressure switch actuates the brake when the pressure drops below the set value.

For accessories, such as tubing and fittings, please refer to our separate catalog.

Required Components

- Three, Three-Way Valves
- Port size M5, G1/8, G1/4, G1/2
- Pressure Regulator G1/8 - G3/8
- Pneumatic Accessories
- P/E-Switch
- Check Valves G1/8 - G3/8
- Flow Control Valves M5 - G1/4

Contact factory for literature on the above valves/accessories



For inventory, lead times, and kit lookup, visit www.pdnplu.com

SLIDELINE, Plain Bearing Guide SL \varnothing 16 to 80mm bore
For Linear-drive

- Series OSP-P

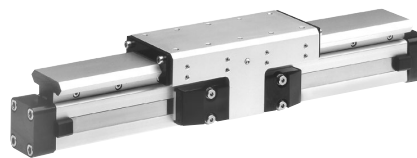
OSP

Features

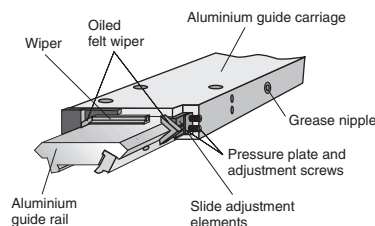
- Maximum speed < 1 m/s
- Adjustable plastic slide elements – optional with integral brake
- Composite sealing system with plastic and felt wiper elements to remove dirt and lubricate the slideways
- Corrosion resistant version available on request
- Any length of stroke up to 5500mm (longer strokes on request)

Integrated Brake (optional)
for series OSP-P25 to OSP-P50:

- Actuated by pressure
- Released by exhausting and spring return

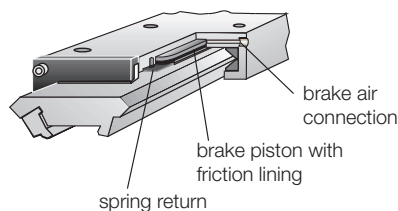
For further technical data see also linear drives OSP-P, see page 14.

Option – Integrated Brake

Loads, Forces and Moments

The table shows the maximum permissible values for smooth operation, which should not be exceeded even under dynamic conditions.

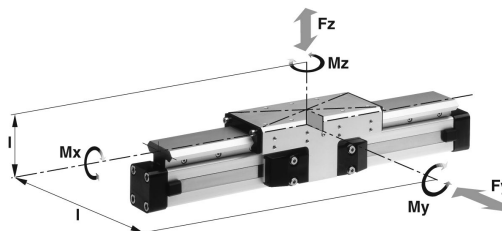
The load and moment figures apply to speeds $v < 0.2$ m/s.



Series	For Linear Drive	Max. Moments (Nm)			Max. Loads (N)		Maximum Braking Force a 6 Bar (N)†	Mass of Linear Drive with Guide (kg)		
		Mx	My	Mz	Fy, Fz	With 0mm stroke		Increase per 100mm Stroke	Mass * of Guide Carriage (kg)	
SL16	OSP-P16	6	11	11	325	–	0.57	0.22	0.23	
SL25	OSP-P25	14	34	34	675	325	1.55	0.39	0.61	
SL32	OSP-P32	29	60	60	925	545	2.98	0.65	0.95	
SL40	OSP-P40	50	110	110	1500	835	4.05	0.78	1.22	
SL50	OSP-P50	77	180	180	2000	1200	6.72	0.97	2.06	
SL63	OSP-P63	120	260	260	2500	–	11.66	1.47	3.32	
SL80	OSP-P80	120	260	260	2500	–	15.71	1.81	3.32	

* Add the mass of the guide carriage to the mass to be cushioned.

† Only with integrated brake: Braking force on dry oil-free surface values are decreased for lubricated slideways.

Rodless Pneumatic Cylinders
OSP-P Series
P1X Series
GDL Series
2002/P120 Series
P55 Electronic & Reed Sensors
Accessories
Part Number Index
Safety Guide, Offer of Sale



For inventory, lead times, and kit lookup, visit www.pdnplu.com

Ordering Information

Ordering information for OSP-P rodless SLIDELINE pneumatic series

1-4	5-6	7	8	9	10	11	12-16	17	18	19	20	21	22	23	24	25			
Bore		Lubrication		Stroke		Cushioning & Stops		Dovetail Cover		Version		Endcap Mounting		Seals		Piston Style			
16 25 32 40 50 63 80		0 Standard 1 Slow Speed		x x x x x 5 digits in whole millimeters (ex. 1100mm = 01100)		0 Standard 1 Long Cushions (25,32,40)		0 Standard		0 Standard		0 None 1 A1 (16,25,32) 2 A2 (16,25,32) 3 A3 (25,32) 4 B1 (25,32) 6 B3 (16) 7 B4 (25,32) 8 B5 (32) 9 C1 (40,50,63,80) A C2 (40,50,63,80) B C3 (40,50,63,80) C C4 (40,50,63,80)		0 Standard 1 Fluorocarbon		0 Standard 1 Tandem			
Porting configurations†				Hardware				Guides / Brakes				Additional Carriages**				Switches †			
0 Standard 1 End Face (16,25,32,40,50,63,80) 2 Single End Porting (25,32,40,50,63,80) 3 Left Std Pos #2, Right Pos #5 (16,25,32,40,50,63,80) 4 Left Pos #5, Right Std Pos #2 (16,25,32,40,50,63,80) 6 Single End Porting at #5 (50,63,80) A 24VDC VOE Valves (25,32,40,50) B 220VAC VOE Valves (25,32,40,50) C 48VDC VOE Valves (25,32,40,50) E 110VAC VOE Valves (25,32,40,50)				0 Standard 1 Stainless Steel				0 None 2 Slideline Guide				0 None 2 Slideline Guide M Guide Carriage without Brake Function				0 None 1 Normally Open Reed Switch (16 thru 80) 2 Normally Closed Reed Switch (16 thru 80) 3 PNP Hall Sensor w/Extension Cables (16 thru 80) 4 NPN Hall Sensor w/Extension Cables (16 thru 80) X SFI 0.1mm RES (25 thru 80) Y SFI 1mm RES (25 thru 80)			
Note: Single end porting on 16mm bore, then end caps cannot be rotated.				Endcap Position				**Note: Available on tandem piston only				† Note: 2 switches will be supplied. For different quantity, please order as a separate line item.							
				0 Both Pos #2 1 Both Pos #3 2 Both Pos #4 3 Both Pos #1 4 Left #3 / Right #2 5 Left #4 / Right #2 6 Left #1 / Right #2 7 Left #2 / Right #3 8 Left #4 / Right #3 9 Left #1 / Right #3 A Left #2 / Right #4 B Left #3 / Right #4 C Left #1 / Right #4 D Left #2 / Right #1 E Left #3 / Right #1 F Left #4 / Right #1															

Cylinder with guide end cap positioning

- Rodless Pneumatic Cylinders
- OSP-P Series
- P1X Series
- GDL Series
- 2002/P120 Series
- P5S Electronic & Reed Sensors
- Accessories
- Part Number Index
- Safety Guide, Offer of Sale



For inventory, lead times, and kit lookup, visit www.pdnplu.com

SLIDELINE \varnothing 16 to 80mm

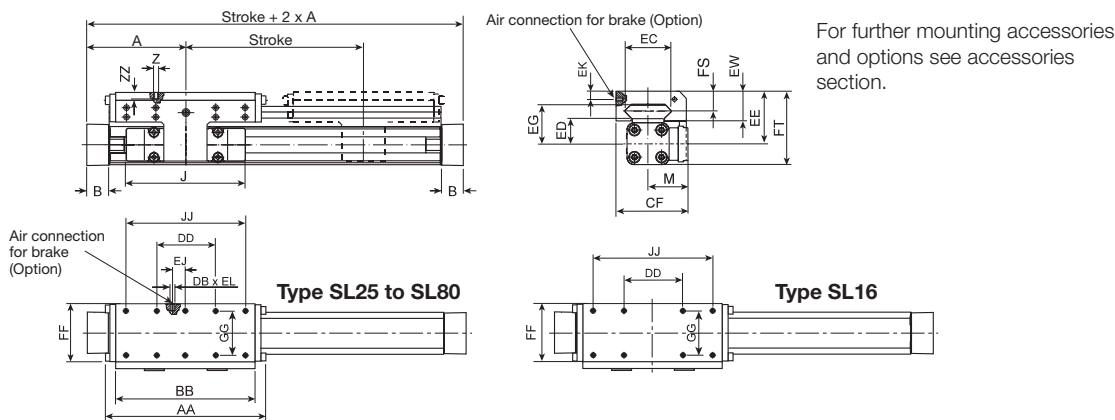

Dimensions (mm)

Series	A	B	J	M	Z	AA	BB	DB	DD	CF	EC	ED	EE	EG	EJ	EK	EL	EW	FF	FT	FS	GG	JJ	ZZ
SL16	65	14	69	31	M4	106	88	-	30	55	36	8	40	30	-	-	22	48	55	14	36	70	8	
SL25	100	22	117	40.5	M6	162	142	M5	60	72.5	47	12	53	39	22	6	6	30	64	73.5	20	50	120	12
SL32	125	25.5	152	49	M6	205	185	M5	80	91	67	14	62	48	32	6	6	33	84	88	21	64	160	12
SL40	150	28	152	55	M6	240	220	M5	100	102	77	14	64	50	58	6	6	34	94	98.5	21.5	78	200	12
SL50	175	33	200	62	M6	284	264	M5	120	117	94	14	75	56	81	6	6	39	110	118.5	26	90	240	16
SL63	215	38	256	79	M8	312	292	-	130	152	116	18	86	66	-	-	-	46	152	139	29	120	260	14
SL80	260	47	348	96	M8	312	292	-	130	169	116	18	99	79	-	-	-	46	152	165	29	120	260	14

Mid-Section Support

(for versions see pages 80 to 83)

Mid-section supports are required from a certain stroke length to prevent excessive deflection and vibration of the linear drive. The diagrams show the maximum permissible unsupported length in relation to loading. A distinction must be drawn between loading 1 and loading 2.

Deflection of 0.5 mm max. between supports is permissible.

Note: For speeds $v > 0.5$ m/s the distance between supports should not exceed 1 m.

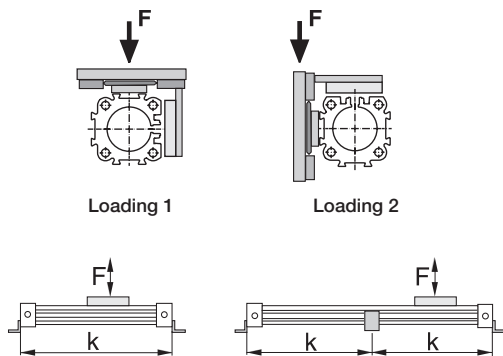

SLIDELINE 16 to 32mm Bore

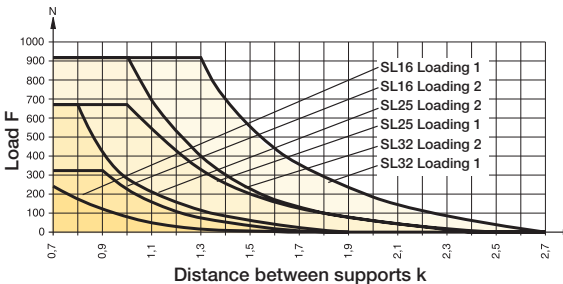

SLIDELINE 40 to 80mm Bore

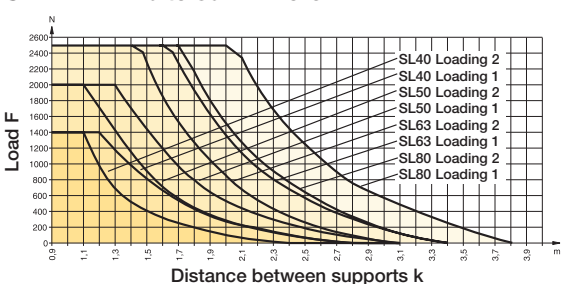

For inventory, lead times, and kit lookup, visit www.pdnplu.com

Rodless Pneumatic Cylinders
OSP-P Series
P1X Series
GDL Series
2002/P120 Series
P55 Electronic & Reed Sensors
Accessories
Part Number Index
Safety Guide, Offer of Sale

Rodless Pneumatic Cylinders
OSP-P Series
P1X Series
GDL Series
2002/P120 Series
P5S Electronic & Reed Sensors
Accessories
Part Number Index
Safety Guide, Offer of Sale

Multi-Brake Passive Brakes MB-SL ø 25 to 80mm bore

Series MB-SL 25 to 80 for Linear-drive

- Series OSP-P



Features

- Brake operated by spring actuation
- Brake release by pressurization
- Anodized aluminum rail, with prism shaped slide elements
- Adjustable plastic slide elements
- Composite sealing system with plastic and felt wiper elements to remove dirt and lubricate the slideway
- Replenishable guide lubrication by integrated grease nipples
- Blocking function in case of pressure loss
- Intermediate stops possible

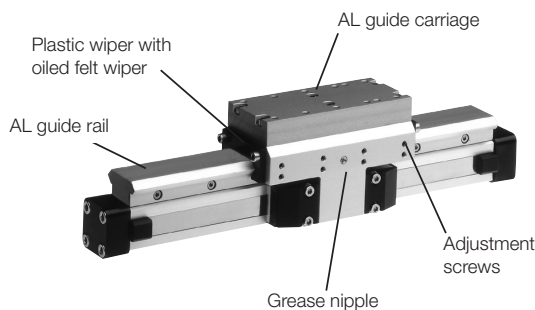

Function

The Multi-Brake is a passive device. When the air pressure is removed the brake is actuated and movement of the cylinder is blocked. The brake is released by pressurization.

The high friction, wear resistant brake linings allow the Multi-Brake to be used as a dynamic brake to stop cylinder movement in the shortest possible time. The powerful springs also allow the Multi-Brake to be used effectively in positioning applications.

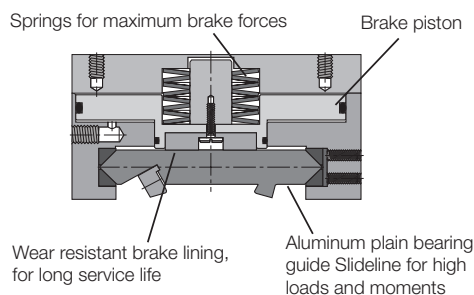

Loads, Forces and Moments

The table shows the maximum values for light, shock-free operation, which must not be exceeded even in dynamic operation.

Load and moment data are based on speeds $v < 0.2$ m/s.

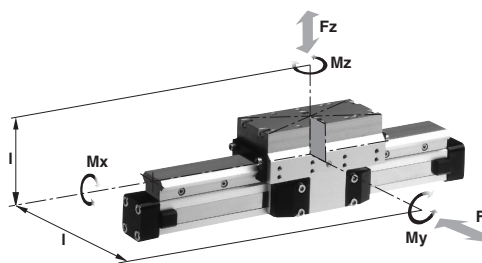

Series	For Linear Drive	Max. Moments (Nm)			Max. Loads (N)	Maximum Braking Force a 6 Bar (N) †	Mass of Linear Drive with Guide (kg)		
		Mx	My	Mz			Fy, Fz	With 0mm Stroke	Increase per 100mm Stroke
MB-SL25	OSP-P25	14	34	34	675	470	2.04	0.39	1.10
MB-SL32	OSP-P32	29	60	60	925	790	3.82	0.65	1.79
MB-SL40	OSP-P40	50	110	110	1500	1200	5.16	0.78	2.34
MB-SL50	OSP-P50	77	180	180	2000	1870	8.29	0.97	3.63
MB-SL63	OSP-P63	120	260	260	2500	2900	13.31	1.47	4.97
MB-SL80	OSP-P80	120	260	260	2500	2900	17.36	1.81	4.97

* Add the mass of the guide carriage to the mass to be cushioned.
 † Braking surface dry – oil on the braking surface will reduce the braking force.



For inventory, lead times, and kit lookup, visit www.pdnplu.com

OSP-P with Passive Brake MB-SL

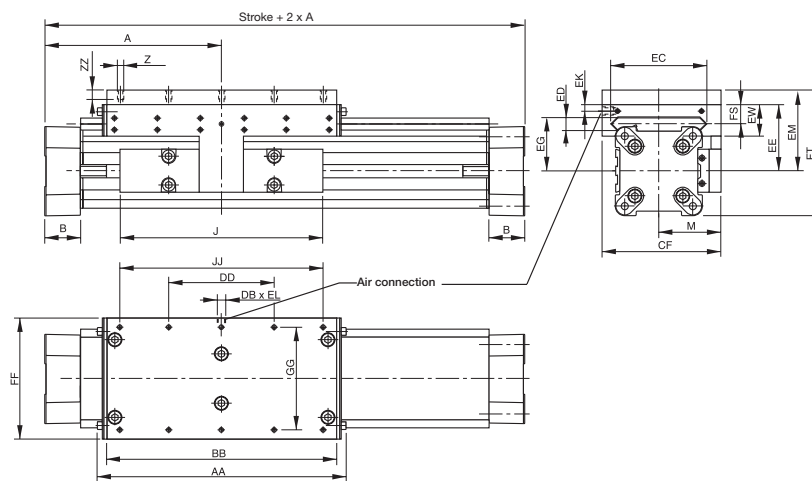

Dimension (mm)

Series	A	B	J	M	Z	AA	BB	DB	DD	CF	EC	ED	EE	EG	EK	EL	EM	EW	FF	FT	FS	GG	JJ	ZZ
MB-SL25	100	22	117	40,5	M6	162	142	M5	60	72,5	47	12	53	39	9	5	73	30	64	93,5	20	50	120	12
MB-SL32	125	25,5	152	49	M6	205	185	G1/8	80	91	67	14	62	48	7	10	82	33	84	108	21	64	160	12
MB-SL40	150	28	152	55	M6	240	220	G1/8	100	102	77	14	64	50	6,5	10	84	34	94	118,5	21,5	78	200	12
MB-SL50	175	33	200	62	M6	284	264	G1/8	120	117	94	14	75	56	10	12	95	39	110	138,5	26	90	240	12
MB-SL63	215	38	256	79	M8	312	292	G1/8	130	152	116	18	86	66	11	12	106	46	152	159	29	120	260	13
MB-SL80	260	47	348	96	M8	312	292	G1/8	130	169	116	18	99	79	11	12	119	46	152	185	29	120	260	13

Mid-Section Support

(for versions see page 83)

Mid-Section supports are required from a certain stroke length to prevent excessive deflection and vibration of the linear drive.

The diagrams show the maximum permissible unsupported length in relation to loading. A distinction must be drawn between loading 1 and loading 2. Deflection of 0.5 mm max. between supports is permissible.

Note: For speeds $v > 0.5$ m/s the distance between supports should not exceed 1 m.

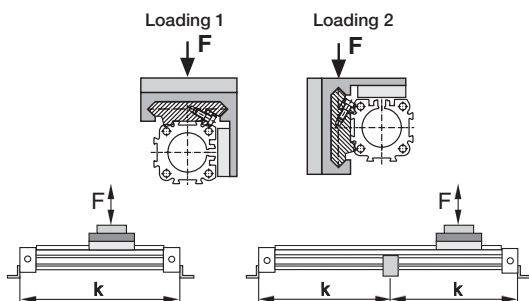

**Permissible Unsupported Length
 MB-SL25, MB-SL32**

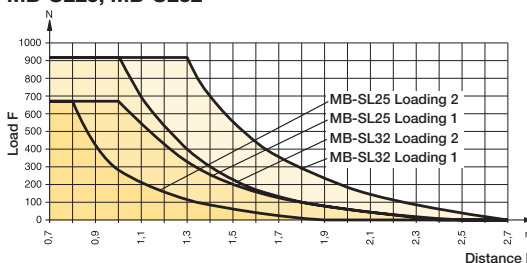

**Permissible Unsupported Length
 MB-SL40, MB-SL50, MB-SL63 and MB-SL80**

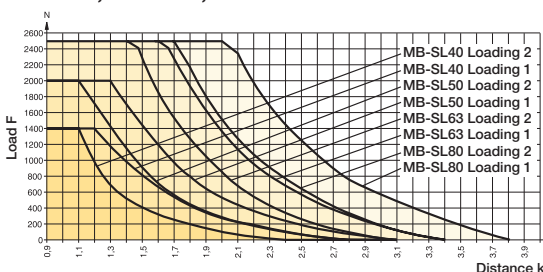

For inventory, lead times, and kit lookup, visit www.pdnplu.com

Rodless Pneumatic Cylinders
OSP-P Series
P1X Series
GDL Series
2002/P120 Series
P55 Electronic & Reed Sensors
Accessories
Part Number Index
Safety Guide, Offer of Sale

Features
Multi-Brake Passive Brakes PS ø 16 to 50mm bore

Series PS 16 to 50 for Linear-drive

- Series OSP-P

Features

- Anodized aluminum guide carriage with vee rollers having 2 rows of ball bearings
- Hardened steel guide rail
- Several guide sizes can be used on the same drive
- Corrosion resistance version available on request
- Max. Speed $v = 3 \text{ m/s}$
- Tough roller cover with wiper and grease nipple
- Any length of stroke up to 3500mm

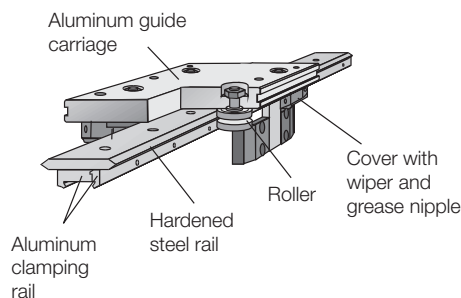
Loads, Forces and Moments

The table shows the maximum permissible values for smooth operation, which should not be exceeded even under dynamic conditions.

For further information and technical data see linear drives OSP-P.

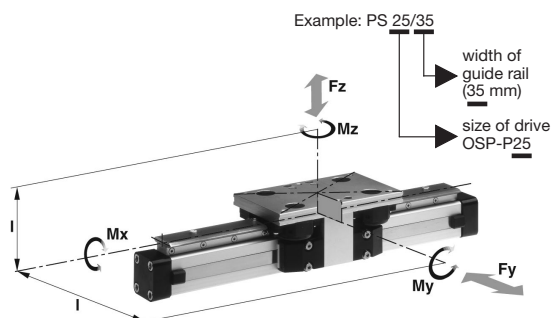

Series	For Linear Drive	Max. Moments (Nm)			Max. Load (N)	Mass of Linear Drive with Guide (kg)		
		Mx	My	Mz		Fy, Fz	With 0mm Stroke	Increase per 100mm Stroke
PS 16/25	OSP-P16	14	45	45	1400	0.93	0.24	0.7
PS 25/25	OSP-P25	14	63	63	1400	1.5	0.4	0.7
PS 25/35	OSP-P25	20	70	70	1400	1.7	0.4	0.8
PS 25/44	OSP-P25	65	175	175	3000	2.6	0.5	1.5
PS 32/35	OSP-P32	20	70	70	1400	2.6	0.6	0.8
PS 32/44	OSP-P32	65	175	175	3000	3.4	0.7	1.5
PS 40/44	OSP-P40	65	175	175	3000	4.6	1.1	1.5
PS 40/60	OSP-P40	90	250	250	3000	6	1.3	2.2
PS 50/60	OSP-P50	90	250	250	3000	7.6	1.4	2.3
PS 50/76	OSP-P50	140	350	350	4000	11.5	1.8	4.9

* Add the mass of the guide carriage to the mass to be cushioned.



For inventory, lead times, and kit lookup, visit www.pdnplu.com

Ordering Information

Ordering information for OSP-P rodless POWERSLIDE pneumatic series

1-4	5-6	7	8	9	10	11	12-16	17	18	19	20	21	22	23	24	25
OSPP	25	0	1		0	0		0	0	0	0	0	0	1	0	0

Bore	Lubrication	Stroke	Cushioning & Stops	Dovetail Cover	Version
16 25 32 40 50	0 Standard 1 Slow Speed	x x x x x 5 digits in whole millimeters (ex. 1100mm = 01100)	0 Standard 1 Long Cushions (25,32,40)	0 Standard X Without Cover Rail	0 Standard

Piston Style	Seals	Hardware	Piston Mounting	Guides / Brakes	Endcap Mounting
0 Standard 1 Tandem	0 Standard 1 Fluorocarbon	0 Standard 1 Stainless Steel	0 None	E PSXX/25 (16,25) F PSXX/35 (25,32) G PSXX/44 (25,32,40) H PSXX/60 (40,50) I PSXX/76 (50)	0 None 1 A1 (16,25,32) 2 A2 (16,25,32) 3 A3 (25,32) 4 B1 (25,32) 6 B3 (16) 7 B4 (25,32) 8 B5 (32) 9 C1 (40,50) A C2 (40,50) B C3 (40,50) C C4 (40,50)

Porting configurations	Endcap Position	Additional Carriages**	Switches [◊]
0 Standard 1 End Face (16,25,32,40,50) 2 Single End Porting (25,32,40,50) 3 Left Std Pos #2, Right Pos #5 (16,25,32,40,50) 4 Left Pos #5, Right Std Pos #2 (16,25,32,40,50) 6 Single End Porting at #5 (50) A 24VDC VOE Valves (25,32,40,50) B 220VAC VOE Valves (25,32,40,50) C 48VDC VOE Valves (25,32,40,50) E 110VAC VOE Valves (25,32,40,50)	0 Both Pos #2 1 Both Pos #3 2 Both Pos #4 3 Both Pos #1 4 Left #3 / Right #2 5 Left #4 / Right #2 6 Left #1 / Right #2 7 Left #2 / Right #3 8 Left #4 / Right #3 9 Left #1 / Right #3 A Left #2 / Right #4 B Left #3 / Right #4 C Left #1 / Right #4 D Left #2 / Right #1 E Left #3 / Right #1 F Left #4 / Right #1	0 None E PSXX/25 (16,25) F PSXX/35 (25,32) G PSXX/44 (25,32,40) H PSXX/50 (40,50) I PSXX/76 (50)	0 None 1 Normally Open Reed Switch (16 thru 50) 2 Normally Closed Reed Switch (16 thru 50) 3 PNP Hall Sensor w/Extension Cables (16 thru 50) 4 NPN Hall Sensor w/Extension cables (16 thru 50) X SFI 0.1mm RES (25 thru 50) Y SFI 1mm RES (25 thru 50)

Note: Single end porting on 16mm bore, then end caps cannot be rotated.

Note: Comes in pairs

[◊] Note: 2 switches will be supplied. For different quantity, please order as a separate line item.

** Note: Available on tandem piston only

Cylinder with guide end cap positioning

Rodless Pneumatic Cylinders
OSP-P Series
P1X Series
GDL Series
2002/P120 Series
P55 Electronic & Reed Sensors
Accessories
Part Number Index
Safety Guide, Offer of Sale



For inventory, lead times, and kit lookup, visit www.pdnplu.com

POWERSLIDE Dimensions

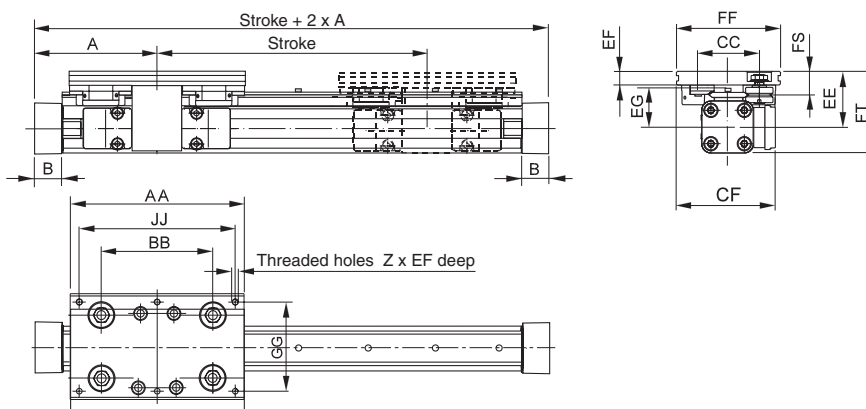

Dimensions (mm)

Series	A	B	Z	AA	BB	CC	CF	EE	EF	EG	FF	FS	FT	GG	JJ
PS 16/25	65	14	4xM6	120	65	47	80	49	12	35	80	21	64	64	100
PS 25/25	100	22	6xM6	145	90	47	79.5	53	11	39	80	20	73.5	64	125
PS 25/35	100	22	6xM6	156	100	57	89.5	52.5	12.5	37.5	95	21.5	73	80	140
PS 25/44	100	22	6xM8	190	118	73	100	58	15	39	116	26	78.5	96	164
PS 32/35	125	25.5	6xM6	156	100	57	95.5	58.5	12.5	43.5	95	21.5	84.5	80	140
PS 32/44	125	25.5	6xM8	190	118	73	107	64	15	45	116	26	90	96	164
PS 40/44	150	28	6xM8	190	118	73	112.5	75	15	56	116	26	109.5	96	164
PS 40/60	150	28	6xM8	240	167	89	122.5	74	17	54	135	28.5	108.5	115	216
PS 50/60	175	33	6xM8	240	167	89	130.5	81	17	61	135	28.5	123.5	115	216
PS 50/76	175	33	6xM10	280	178	119	155.5	93	20	64	185	39	135.5	160	250

Service Life

Calculation of service life is achieved in two stages:

- Determination of load factor L_F from the loads to be carried
- Calculation of service life in km

1. Calculation of load factor L_F

$$L_F = \frac{M_x}{M_{x_{max}}} + \frac{M_y}{M_{y_{max}}} + \frac{M_z}{M_{z_{max}}} + \frac{F_y}{F_{y_{max}}} + \frac{F_z}{F_{z_{max}}}$$

with combined loads, L_F should not exceed the value 1.

Lubrication

For maximum system life, lubrication of the rollers must be maintained at all times.

Only high quality Lithium based greases should be used.

Lubrication intervals are dependent on environmental conditions (temperature, running speed, grease quality etc.) therefore the installation should be regularly inspected.

2. Service life calculation

- For PS 16/25, PS 25/25, PS 25/35, and PS 32/35: Service life (km) = $\frac{106}{(L_F + 0,02)^3}$
- For PS 25/44, PS 32/44, PS 40/44, PS 40/60 and PS 50/60: Service life (km) = $\frac{314}{(L_F + 0,015)^3}$
- For PS 50/76: Service life (km) = $\frac{680}{(L_F + 0,015)^3}$



For inventory, lead times, and kit lookup, visit www.pdnplu.com

Mid-Section Support

(for versions see page 83)

Mid-section supports are required from a certain stroke length to prevent excessive deflection and vibration of the linear drive. The diagrams show the maximum permissible unsupported length in relation to loading. A distinction must be drawn between loading 1 and loading 2.

Deflection of 0.5 mm max. between supports is permissible.

Note: For speeds $v > 0.5$ m/s the distance between supports should not exceed 1 m.

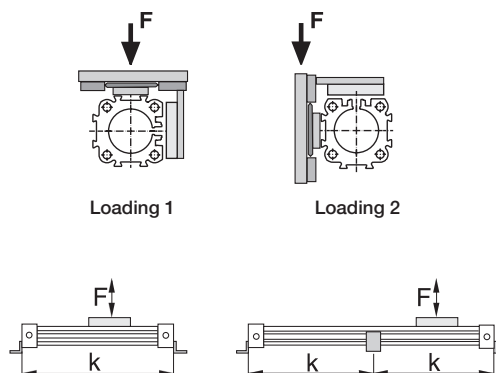

**Permissible unsupported length:
 POWERSLIDE 16/25, 25/25, 25/35, 25/44mm bore**

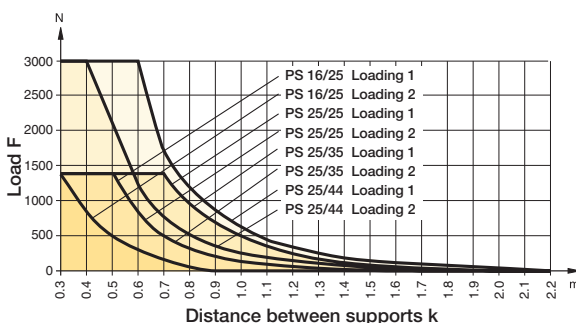

**Permissible unsupported length:
 POWERSLIDE 2/35, 32/44mm bore**

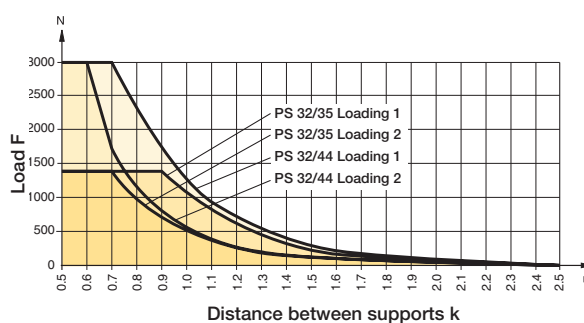

**Permissible unsupported length:
 POWERSLIDE 40/44, 40/60mm bore**

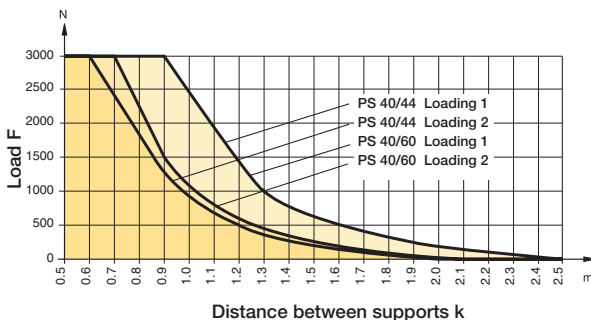

**Permissible unsupported length:
 POWERSLIDE 50/60, 50/76mm bore**

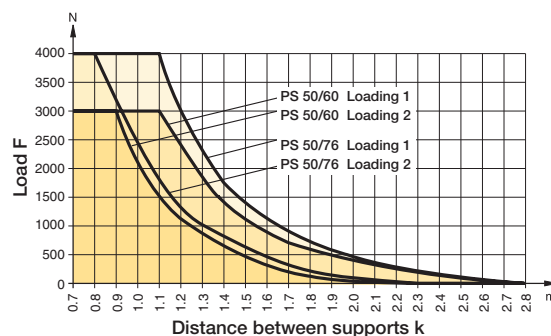

Rodless Pneumatic Cylinders
OSP-P Series
P1X Series
GDL Series
2002/P120 Series
P55 Electronic & Reed Sensors
Accessories
Part Number Index
Safety Guide, Offer of Sale



For inventory, lead times, and kit lookup, visit www.pdnplu.com

Features
Aluminum Roller Guide PROLINE PL ø 16 to 50mm bore
Series PL 16 to 50 for Linear-drive

- Series OSP-P

Features

- High precision
- High velocities (10 m/s)
- Smooth operation - low noise
- Integrated wiper system
- Long life lubrication
- Compact dimensions - compatible to Slideline plain bearing guide
- Any length of stroke up to 3750mm

Integrated Brake (optional) for Series OSP-P25 to OSP-P50:

- Actuated by pressurization
- Release by depressurization and spring actuation

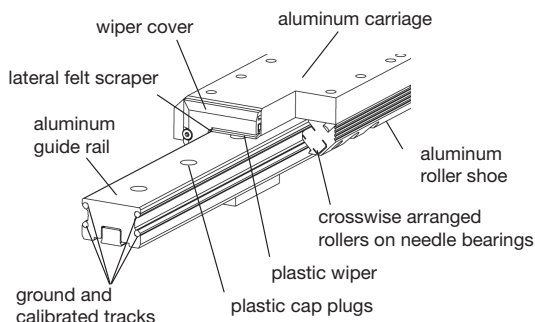
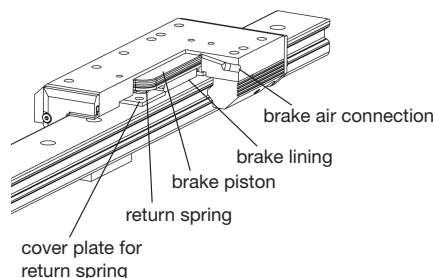

Option - Integrated Brake

Loads, Forces and Moments

The table shows the maximal permissible loads. If multiple moments and forces act upon the cylinder simultaneously, the following equation applies:

$$\frac{M_x}{M_{x\max}} + \frac{M_y}{M_{y\max}} + \frac{M_z}{M_{z\max}} + \frac{F_y}{F_{y\max}} + \frac{F_z}{F_{z\max}} \leq 1$$

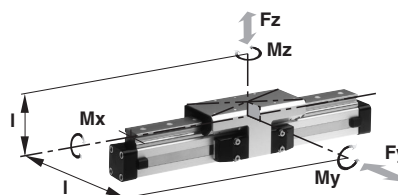
The sum of the loads should not exceed >1. With a load factor of less than 1, service life is 8000 km

The table shows the maximum permissible values for light, shock-free operation, which must not be exceeded even under dynamic conditions.



Series	For Linear Drive	Max. Moments (Nm)			Max. Loads (N)	Maximum Braking Force at 6 bar (N) †	Mass of Linear Drive with Guide (kg)		
		Mx	My	Mz	Fy, Fz		With 0mm Stroke	Increase per 100mm Stroke	Mass * Guide Carriage (kg)
PL16	OSP-P16	8	12	12	542	-	0.55	0.19	0.24
PL25	OSP-P25	16	39	39	857	on request	1.65	0.40	0.75
PL32	OSP-P32	29	73	73	1171	on request	3.24	0.62	1.18
PL40	OSP-P40	57	158	158	2074	on request	4.35	0.70	1.70
PL50	OSP-P50	111	249	249	3111	on request	7.03	0.95	2.50

* Add the mass of the guide carriage to the mass to be cushioned.

† Only for version with brake: Braking surface dry – oiled surface reduces the effective braking force.



For inventory, lead times, and kit lookup, visit www.pdnplu.com

Ordering information for OSP-P rodless PROLINE pneumatic series

1-4	5-6	7	8	9	10	11	12-16	17	18	19	20	21	22	23	24	25
OSPP	25	0	1		0	0		0	0	0	0	0	0	1	0	0

<p>Bore</p> <table border="1" style="width:100%; border-collapse: collapse;"> <tr><td>16</td></tr> <tr><td>25</td></tr> <tr><td>32</td></tr> <tr><td>40</td></tr> <tr><td>50</td></tr> </table>	16	25	32	40	50	<p>Lubrication</p> <table border="1" style="width:100%; border-collapse: collapse;"> <tr><td>0</td><td>Standard</td></tr> </table>	0	Standard	<p>Stroke</p> <table border="1" style="width:100%; border-collapse: collapse;"> <tr><td>x x x x x</td></tr> </table> <p>5 digits in whole millimeters (ex. 1100mm = 01100)</p>	x x x x x	<p>Cushioning & Stops</p> <table border="1" style="width:100%; border-collapse: collapse;"> <tr><td>0</td><td>Standard</td></tr> <tr><td>1</td><td>Long Cushions (25,32,40)</td></tr> </table>	0	Standard	1	Long Cushions (25,32,40)																																																				
16																																																																			
25																																																																			
32																																																																			
40																																																																			
50																																																																			
0	Standard																																																																		
x x x x x																																																																			
0	Standard																																																																		
1	Long Cushions (25,32,40)																																																																		
<p>Seals</p> <table border="1" style="width:100%; border-collapse: collapse;"> <tr><td>0</td><td>Standard</td></tr> <tr><td>1</td><td>Fluorocarbon</td></tr> </table>	0	Standard	1	Fluorocarbon	<p>Piston style</p> <table border="1" style="width:100%; border-collapse: collapse;"> <tr><td>0</td><td>Standard</td></tr> <tr><td>1</td><td>Tandem</td></tr> </table>	0	Standard	1	Tandem	<p>Hardware</p> <table border="1" style="width:100%; border-collapse: collapse;"> <tr><td>0</td><td>Standard</td></tr> <tr><td>1</td><td>Stainless Steel</td></tr> </table>	0	Standard	1	Stainless Steel	<p>Piston Mounting</p> <table border="1" style="width:100%; border-collapse: collapse;"> <tr><td>0</td><td>None</td></tr> </table>	0	None																																																		
0	Standard																																																																		
1	Fluorocarbon																																																																		
0	Standard																																																																		
1	Tandem																																																																		
0	Standard																																																																		
1	Stainless Steel																																																																		
0	None																																																																		
<p>Porting Configurations</p> <table border="1" style="width:100%; border-collapse: collapse;"> <tr><td>0</td><td>Standard</td></tr> <tr><td>1</td><td>End Face (16,25,32,40,50)</td></tr> <tr><td>2</td><td>Single End Porting (25,32,40,50)</td></tr> <tr><td>3</td><td>Left Std Pos #2, Right Pos #5 (16,25,32,40,50)</td></tr> <tr><td>4</td><td>Left Pos #5, Right Std Pos #2 (16,25,32,40,50)</td></tr> <tr><td>6</td><td>Single End Porting at #5 (50)</td></tr> <tr><td>A</td><td>24VDC VOE Valves (25,32,40,50)</td></tr> <tr><td>B</td><td>220VAC VOE Valves (25,32,40,50)</td></tr> <tr><td>C</td><td>48VDC VOE Valves (25,32,40,50)</td></tr> <tr><td>E</td><td>110VAC VOE Valve (25,32,40,50)</td></tr> </table> <p>Note: Single end porting on 16mm bore, then end caps cannot be rotated.</p>	0	Standard	1	End Face (16,25,32,40,50)	2	Single End Porting (25,32,40,50)	3	Left Std Pos #2, Right Pos #5 (16,25,32,40,50)	4	Left Pos #5, Right Std Pos #2 (16,25,32,40,50)	6	Single End Porting at #5 (50)	A	24VDC VOE Valves (25,32,40,50)	B	220VAC VOE Valves (25,32,40,50)	C	48VDC VOE Valves (25,32,40,50)	E	110VAC VOE Valve (25,32,40,50)	<p>Endcap Position</p> <table border="1" style="width:100%; border-collapse: collapse;"> <tr><td>0</td><td>Both Pos #2</td></tr> <tr><td>1</td><td>Both Pos #3</td></tr> <tr><td>2</td><td>Both Pos #4</td></tr> <tr><td>3</td><td>Both Pos #1</td></tr> <tr><td>4</td><td>Left #3 / Right #2</td></tr> <tr><td>5</td><td>Left #4 / Right #2</td></tr> <tr><td>6</td><td>Left #1 / Right #2</td></tr> <tr><td>7</td><td>Left #2 / Right #3</td></tr> <tr><td>8</td><td>Left #4 / Right #3</td></tr> <tr><td>9</td><td>Left #1 / Right #3</td></tr> <tr><td>A</td><td>Left #2 / Right #4</td></tr> <tr><td>B</td><td>Left #3 / Right #4</td></tr> <tr><td>C</td><td>Left #1 / Right #4</td></tr> <tr><td>D</td><td>Left #2 / Right #1</td></tr> <tr><td>E</td><td>Left #3 / Right #1</td></tr> <tr><td>F</td><td>Left #4 / Right #1</td></tr> </table>	0	Both Pos #2	1	Both Pos #3	2	Both Pos #4	3	Both Pos #1	4	Left #3 / Right #2	5	Left #4 / Right #2	6	Left #1 / Right #2	7	Left #2 / Right #3	8	Left #4 / Right #3	9	Left #1 / Right #3	A	Left #2 / Right #4	B	Left #3 / Right #4	C	Left #1 / Right #4	D	Left #2 / Right #1	E	Left #3 / Right #1	F	Left #4 / Right #1	<p>Guides / Brakes</p> <table border="1" style="width:100%; border-collapse: collapse;"> <tr><td>6</td><td>Proline Guide (16,25,32,40,50)</td></tr> <tr><td>7</td><td>Proline with Activebrake (25,32,40,50)</td></tr> <tr><td>8</td><td>Proline with Multibrake (25, 32,40,50)</td></tr> </table>	6	Proline Guide (16,25,32,40,50)	7	Proline with Activebrake (25,32,40,50)	8	Proline with Multibrake (25, 32,40,50)	<p>Additional Carriages**</p> <table border="1" style="width:100%; border-collapse: collapse;"> <tr><td>0</td><td>None</td></tr> <tr><td>6</td><td>Proline Guide</td></tr> <tr><td>M</td><td>Guide Carriage without Brake Function</td></tr> </table> <p>** Note: Available on tandem piston only</p>	0	None	6	Proline Guide	M	Guide Carriage without Brake Function
0	Standard																																																																		
1	End Face (16,25,32,40,50)																																																																		
2	Single End Porting (25,32,40,50)																																																																		
3	Left Std Pos #2, Right Pos #5 (16,25,32,40,50)																																																																		
4	Left Pos #5, Right Std Pos #2 (16,25,32,40,50)																																																																		
6	Single End Porting at #5 (50)																																																																		
A	24VDC VOE Valves (25,32,40,50)																																																																		
B	220VAC VOE Valves (25,32,40,50)																																																																		
C	48VDC VOE Valves (25,32,40,50)																																																																		
E	110VAC VOE Valve (25,32,40,50)																																																																		
0	Both Pos #2																																																																		
1	Both Pos #3																																																																		
2	Both Pos #4																																																																		
3	Both Pos #1																																																																		
4	Left #3 / Right #2																																																																		
5	Left #4 / Right #2																																																																		
6	Left #1 / Right #2																																																																		
7	Left #2 / Right #3																																																																		
8	Left #4 / Right #3																																																																		
9	Left #1 / Right #3																																																																		
A	Left #2 / Right #4																																																																		
B	Left #3 / Right #4																																																																		
C	Left #1 / Right #4																																																																		
D	Left #2 / Right #1																																																																		
E	Left #3 / Right #1																																																																		
F	Left #4 / Right #1																																																																		
6	Proline Guide (16,25,32,40,50)																																																																		
7	Proline with Activebrake (25,32,40,50)																																																																		
8	Proline with Multibrake (25, 32,40,50)																																																																		
0	None																																																																		
6	Proline Guide																																																																		
M	Guide Carriage without Brake Function																																																																		
<p>Dovetail cover</p> <table border="1" style="width:100%; border-collapse: collapse;"> <tr><td>0</td><td>Standard</td></tr> <tr><td>X</td><td>Without Cover Rail</td></tr> </table>	0	Standard	X	Without Cover Rail	<p>Version</p> <table border="1" style="width:100%; border-collapse: collapse;"> <tr><td>0</td><td>Standard</td></tr> </table>	0	Standard	<p>Endcap Mounting</p> <table border="1" style="width:100%; border-collapse: collapse;"> <tr><td>0</td><td>None</td></tr> <tr><td>1</td><td>A1 (16,25,32)</td></tr> <tr><td>2</td><td>A2 (16,25,32)</td></tr> <tr><td>3</td><td>A3 (25,32)</td></tr> <tr><td>4</td><td>B1 (25,32)</td></tr> <tr><td>6</td><td>B3 (16)</td></tr> <tr><td>7</td><td>B4 (25,32)</td></tr> <tr><td>8</td><td>B5 (32)</td></tr> <tr><td>9</td><td>C1 (40,50)</td></tr> <tr><td>A</td><td>C2 (40,50)</td></tr> <tr><td>B</td><td>C3 (40,50)</td></tr> <tr><td>C</td><td>C4 (40,50)</td></tr> </table> <p>Note: Comes in pairs</p>	0	None	1	A1 (16,25,32)	2	A2 (16,25,32)	3	A3 (25,32)	4	B1 (25,32)	6	B3 (16)	7	B4 (25,32)	8	B5 (32)	9	C1 (40,50)	A	C2 (40,50)	B	C3 (40,50)	C	C4 (40,50)	<p>Switches [◊]</p> <table border="1" style="width:100%; border-collapse: collapse;"> <tr><td>0</td><td>None</td></tr> <tr><td>1</td><td>Normally Open Reed Switch (16 thru 50)</td></tr> <tr><td>2</td><td>Normally Closed Reed Switch (16 thru 50)</td></tr> <tr><td>3</td><td>PNP Hall Sensor w/Extension Cables (16 thru 50)</td></tr> <tr><td>4</td><td>NPN Hall Sensor w/Extension Cables (16 thru 50)</td></tr> <tr><td>X</td><td>SFI 0.1mm RES (25 thru 50)</td></tr> <tr><td>Y</td><td>SFI 1mm RES (25 thru 50)</td></tr> </table> <p>◊ Note: 2 switches will be supplied. For different quantity, please order as a separate line item.</p>	0	None	1	Normally Open Reed Switch (16 thru 50)	2	Normally Closed Reed Switch (16 thru 50)	3	PNP Hall Sensor w/Extension Cables (16 thru 50)	4	NPN Hall Sensor w/Extension Cables (16 thru 50)	X	SFI 0.1mm RES (25 thru 50)	Y	SFI 1mm RES (25 thru 50)																				
0	Standard																																																																		
X	Without Cover Rail																																																																		
0	Standard																																																																		
0	None																																																																		
1	A1 (16,25,32)																																																																		
2	A2 (16,25,32)																																																																		
3	A3 (25,32)																																																																		
4	B1 (25,32)																																																																		
6	B3 (16)																																																																		
7	B4 (25,32)																																																																		
8	B5 (32)																																																																		
9	C1 (40,50)																																																																		
A	C2 (40,50)																																																																		
B	C3 (40,50)																																																																		
C	C4 (40,50)																																																																		
0	None																																																																		
1	Normally Open Reed Switch (16 thru 50)																																																																		
2	Normally Closed Reed Switch (16 thru 50)																																																																		
3	PNP Hall Sensor w/Extension Cables (16 thru 50)																																																																		
4	NPN Hall Sensor w/Extension Cables (16 thru 50)																																																																		
X	SFI 0.1mm RES (25 thru 50)																																																																		
Y	SFI 1mm RES (25 thru 50)																																																																		

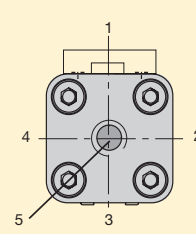

Note: Position #2 is the standard location.

Rodless Pneumatic Cylinders
OSP-P Series
P1X Series
GDL Series
2002/P120 Series
P55 Electronic & Reed Sensors
Accessories
Part Number Index
Safety Guide, Offer of Sale



For inventory, lead times, and kit lookup, visit www.pdnplu.com

OSP-P PROLINE PL16, PL25, PL32, PL40, PL50

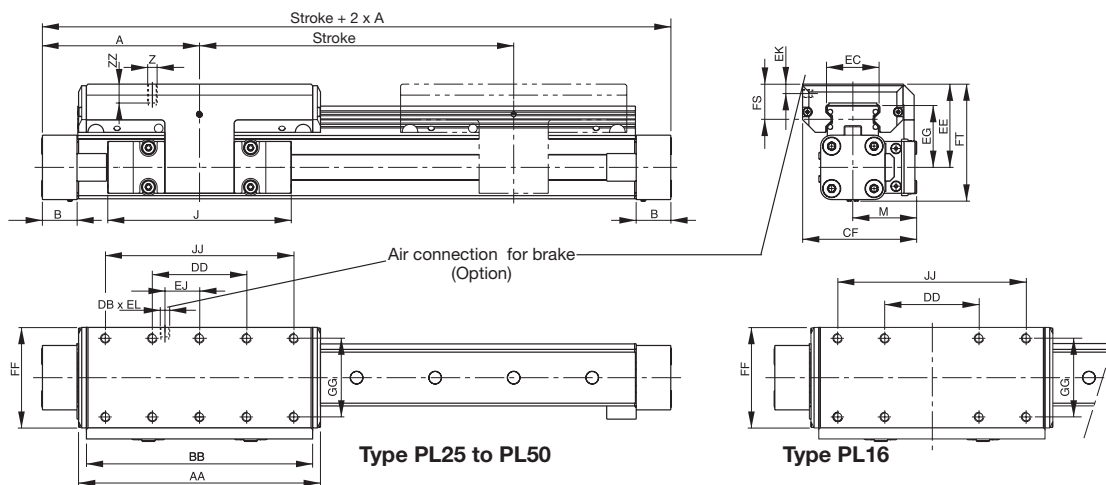

Dimension (mm)

Series	A	B	J	M	Z	AA	BB	DB	DD	CF	EC	EE	EG	EJ	EK	EL	FF	FS	FT	GG	JJ	ZZ
PL16	65	14	69	31	M4	98	88	-	30	55	23	40	30	-	-	-	48	17	55	36	70	8
PL25	100	22	117	40.5	M6	154	144	M5	60	72.5	32.5	53	39	22	6	6	64	23	73.5	50	120	12
PL32	125	25.5	152	49	M6	197	187	M5	80	91	42	62	48	32	6	6	84	25	88	64	160	12
PL40	150	28	152	55	M6	232	222	M5	100	102	47	64	50.5	58	6	6	94	23.5	98.5	78	200	12
PL50	175	33	200	62	M6	276	266	M5	120	117	63	75	57	81	6	6	110	29	118.5	90	240	16

Mid-Section Support

(For versions, see page 83)

Mid-section supports are required from a certain stroke length to prevent excessive deflection and vibration of the linear drive. The diagrams

show the maximum permissible unsupported length in relation to loading. A distinction must be drawn between loading 1 and loading 2. Deflection of 0.5 mm max. between supports is permissible.

Note: For speeds $v > 0.5$ m/s the distance between supports should not exceed 1 m.

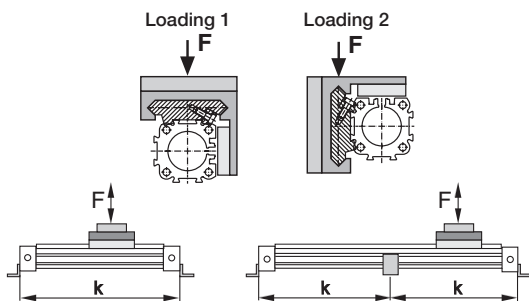

**Permissible Unsupported Length
 PL16, PL25, PL32, PL40 and PL50**

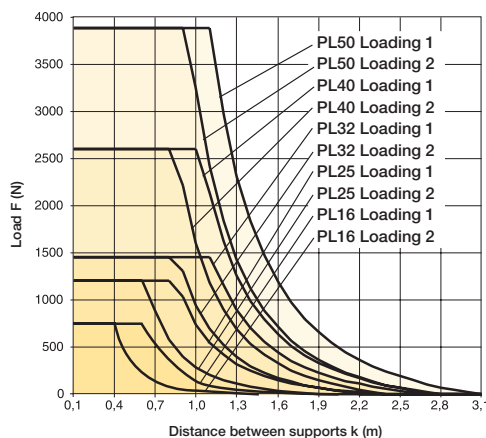

For inventory, lead times, and kit lookup, visit www.pdnplu.com

Features

Multi-Brake Passive Brake with Aluminum Roller Guide PROLINE PL 25 to 50mm bore

Series MB-PL 25 to 50 for Linear-drive



- Series OSP-P

Features

- Brake operated by spring actuation
- Brake release by pressurization
- Optional sensor to indicate brake lining wear
- Composite sealing system with plastic and felt wiper elements to remove dirt and lubricate the slideway
- Blocking function in case of pressure loss
- Intermediate stops possible

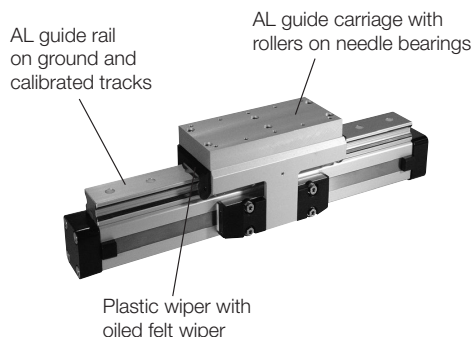

Function

The Multi-Brake is a passive device. When the air pressure is removed the brake is actuated and movement of the cylinder is blocked. The brake is released by pressurization.

The high friction, wear resistant brake linings allow the Multi-Brake to be used as a dynamic brake to stop cylinder movement in the shortest possible time. The powerful springs also allow the Multi-Brake to be used effectively in positioning applications.

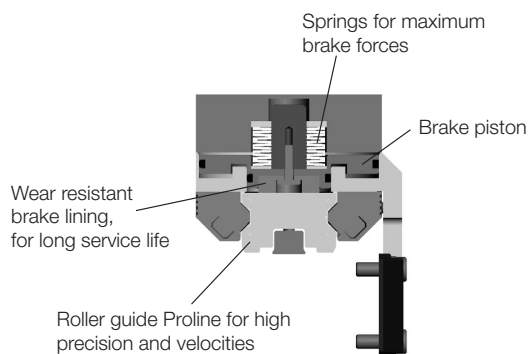

Loads, Forces and Moments

The table shows the maximal permissible loads. If multiple moments and forces act upon the cylinder simultaneously, the following equation applies:

$$\frac{M_x}{M_{xmax}} + \frac{M_y}{M_{ymax}} + \frac{M_z}{M_{zmax}} + \frac{F_y}{F_{ymax}} + \frac{F_z}{F_{zmax}} \leq 1$$

The sum of the loads should not exceed >1. With a load factor of less than 1, service life is 8000 km

The table shows the maximum permissible values for light, shock-free operation, which must not be exceeded even under dynamic conditions.

Operating Pressure 4.5 - 8 bar.

A pressure of min. 4.5 bar release the brake.

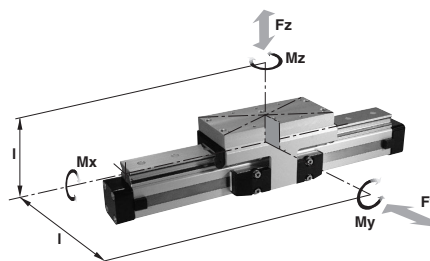

Series	For Linear Drive	Max. Moments (Nm)			Max. Loads (N)		Mass of Linear Drive with guide (kg)		
		Mx	My	Mz	Fy, Fz	Max. Braking Force (N) †	With 0mm Stroke	Increase per 100mm Stroke	Mass* Guide Carriage (kg)
MB-PL25	OSP-P25	16	39	39	857	315	2.14	0.40	1.24
MB-PL32	OSP-P32	29	73	73	1171	490	4.08	0.62	2.02
MB-PL40	OSP-P40	57	158	158	2074	715	5.46	0.70	2.82
MB-PL50	OSP-P50	111	249	249	3111	1100	8.60	0.95	4.07

* Add the mass of the guide carriage to the mass to be cushioned.

† Only for version with brake: Braking surface dry – oiled surface reduces the effective braking force.

Rodless Pneumatic Cylinders
OSP-P Series
P1X Series
GDL Series
2002/P120 Series
P55 Electronic & Reed Sensors
Accessories
Part Number Index
Safety Guide, Offer of Sale



For inventory, lead times, and kit lookup, visit www.pdnplu.com

OSP-P with PROLINE Passive Brake MB-PL25, PL32, PL40, PL50

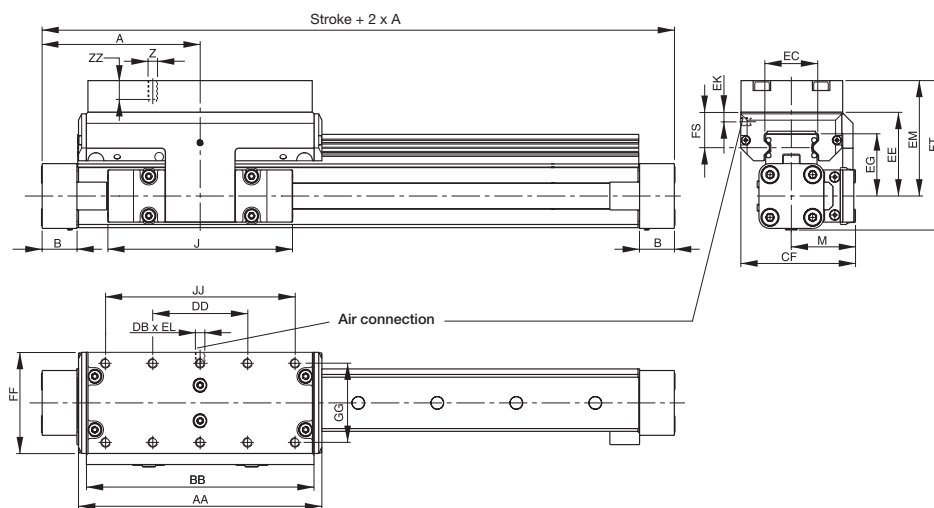

Dimension (mm)

Series	A	B	J	M	Z	AA	BB	DB	DD	CF	EC	EE	EG	EK	EL	EM	FF	FS	FT	GG	JJ	ZZ
MB-PL25	100	22	117	40.5	M6	154	144	M5	60	72.5	32.5	53	39	9	5	73	64	23	93.5	50	120	12
MB-PL32	125	25.5	152	49	M6	197	187	G1/8	80	91	42	62	48	7	10	82	84	25	108	64	160	12
MB-PL40	150	28	152	55	M6	232	222	G1/8	100	102	47	64	50.5	6.5	10	84	94	23.5	118.5	78	200	12
MB-PL50	175	33	200	62	M6	276	266	G1/8	120	117	63	75	57	10	12	95	110	29	138.5	90	240	16

Mid-Section Support

(for versions see page 83)

Mid-Section supports are required from a certain stroke length to prevent

excessive deflection and vibration of the linear drive. The diagrams show the maximum permissible unsupported length in relation to loading.

A distinction must be drawn between loading 1 and loading 2. Deflection of 0.5 mm max. between supports is permissible.

Note: For speeds $v > 0.5$ m/s the distance between supports should not exceed 1 m.

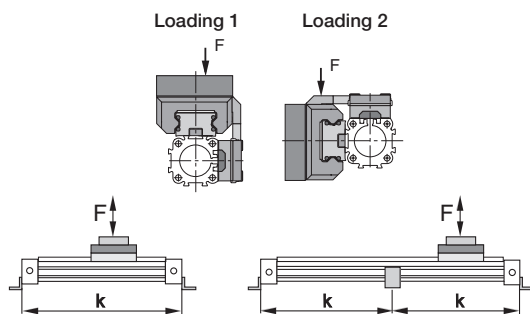

**Permissible Unsupported Length OSP-P
 MB-PL25, MB-PL32, MB-PL40, MB-PL50**

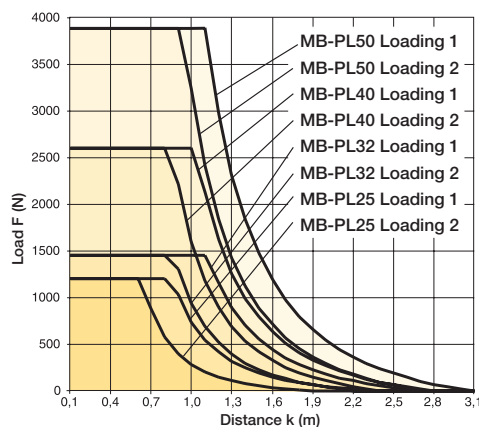

For inventory, lead times, and kit lookup, visit www.pdnplu.com

Features

Recirculating Ball Bearing Guide STARLINE PL 16 to 50mm bore

Series PL 16 to 50 for Linear-drive

- Series OSP-P



Features

- Polished and hardened steel guide rail
- For very high loads in all directions
- High precision
- Integrated wiper system
- Integrated grease nipples
- Any length of stroke up to 3700 mm
- Anodized aluminum guide carriage – dimensions compatible with OSP guides SLIDELINE and PROLINE
- Installation height (STL16 - 32) compatible with OSP guides SLIDELINE and PROLINE
- Maximum speed
STL16: v = 3 m/s
STL25 to 50: v = 5 m/s

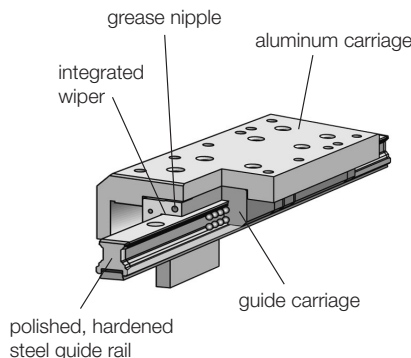
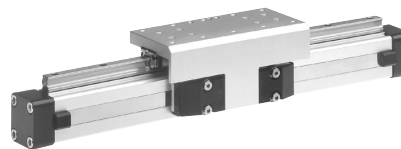

Loads, Forces and Moments

The table shows the maximum permissible loads. If multiple moments and forces act upon the cylinder simultaneously, the following equation applies:

$$\frac{M_x}{M_{xmax}} + \frac{M_y}{M_{ymax}} + \frac{M_z}{M_{zmax}} + \frac{F_y}{F_{ymax}} + \frac{F_z}{F_{zmax}} \leq 1$$

The sum of the loads should not exceed >1.

The table shows the maximum permissible values for light, shock-free operation, which must not be exceeded even under dynamic conditions.

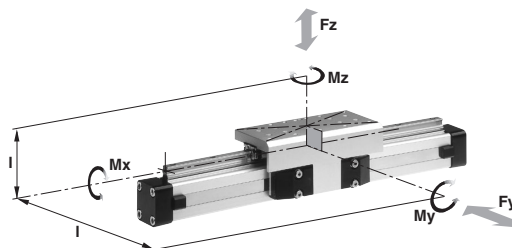

Series	For Linear Drive	Max. Moments (Nm)			Max. Loads (N)		Mass of Linear Drive with Guide (kg)		
		Mx	My	Mz	Fy	Fz	With 0mm Stroke	Increase per 100mm Stroke	Mass * Guide Carriage (kg)
STL16	OSP-P16	15	30	30	1000	1000	0.598	0.210	0.268
STL25	OSP-P25	50	110	110	3100	3100	1.733	0.369	0.835
STL32	OSP-P32	62	160	160	3100	3100	2.934	0.526	1.181
STL40	OSP-P40	150	400	400	4000	7500	4.452	0.701	1.901
STL50	OSP-P50	210	580	580	4000	7500	7.361	0.936	2.880

* Add the mass of the guide carriage to the mass to be cushioned.

Rodless Pneumatic Cylinders
OSP-P Series
P1X Series
GDL Series
2002/P120 Series
P55 Electronic & Reed Sensors
Accessories
Part Number Index
Safety Guide, Offer of Sale



For inventory, lead times, and kit lookup, visit www.pdnplu.com

Ordering Information

Ordering information for OSP-P rodless STARLINE pneumatic series

- Rodless Pneumatic Cylinders
- OSP-P Series
- P1X Series
- GDL Series
- 2002/P120 Series
- P55 Electronic & Reed Sensors
- Accessories
- Part Number Index
- Safety Guide, Offer of Sale

1-4	5-6	7	8	9	10	11	12-16	17	18	19	20	21	22	23	24	25			
OSPP	25	0	1	0	0	0	0	0	0	0	B	0	0	1	0	0			
Bore		Lubrication		Stroke		Piston Mounting		Dovetail Cover		Version		Seals		Hardware		Cushioning & Stops			
16 25 32 40 50		0 Standard 1 Fluorocarbon		x x x x x 5 digits in whole millimeters (ex. 1100mm = 01100)		0 None		0 Standard X Without Cover Rail		0 Standard 1 Standard		0 Standard 1 Fluorocarbon		0 Standard		0 Standard 1 None			
Piston Style		Porting Configurations		Endcap Position		Guides / Brakes		Additional Carriages**		Endcap Mounting		Switches [◇]							
0 Standard 1 Tandem		0 Standard 1 End Face (16,25,32,40,50) 2 Single End Porting (25,32,40,50) 3 Left Std Pos #2, Right Pos #5 (16,25,32,40,50) 4 Left Pos #5, Right Std Pos #2 (16,25,32,40,50) 6 Single End Porting at #5 (50) A 24VDC VOE Valves (25,32,40,50) B 220VAC VOE Valves (25,32,40,50) C 48VDC VOE Valves (25,32,40,50) E 110VAC VOE Valves (25,32,40,50)		0 Both Pos #2 1 Both Pos #3 2 Both Pos #4 3 Both Pos #1 4 Left #3 / Right #2 5 Left #4 / Right #2 6 Left #1 / Right #2 7 Left #2 / Right #3 8 Left #4 / Right #3 9 Left #1 / Right #3 A Left #2 / Right #4 B Left #3 / Right #4 C Left #1 / Right #4 D Left #2 / Right #1 E Left #3 / Right #1 F Left #4 / Right #1 S Special		B Starline Guide		0 None B Starline		0 None 4 B1 (25,32) 6 B3 (16) 7 B4 (25,32) 8 B5 (32) 9 C1 (40,50) A C2 (40,50) B C3 (40,50) C C4 (40,50)		0 None 1 Normally Open Reed Switch (16 thru 50) 2 Normally Closed Reed Switch (16 thru 50) 3 PNP Hall Sensor w/Extension Cables (16 thru 50) 4 NPN Hall Sensor w/Extension Cables (16 thru 50) X SFI 0.1mm RES (25 thru 50) Y SFI 1mm RES (25 thru 50)		Note: Comes in pairs					
		Note: Single end porting on 16mm bore, then end caps cannot be rotated.		** Note: Available on tandem piston only								◇ Note: 2 switches will be supplied. For different quantity, please order as a separate line item.							

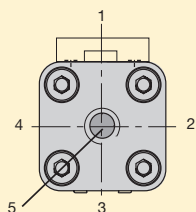

Note: Position #2 is the standard location.



For inventory, lead times, and kit lookup, visit www.pdnplu.com

OSP-P with STARLINE Recirculating Ball Bearing Guide STL16, STL25, STL32, STL40, STL50

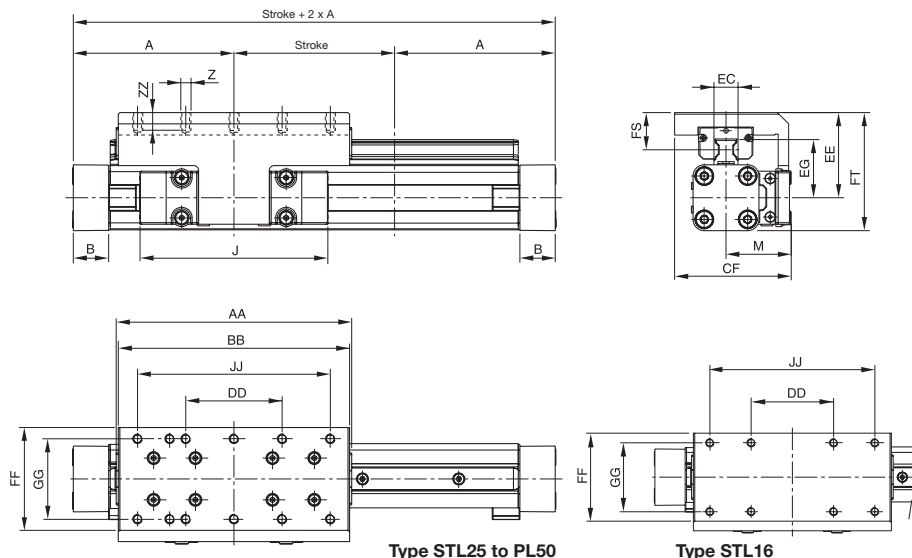

Dimension (mm)

Series	A	B	J	M	Z	AA	BB	CF	DD	EC	EE	EG	FF	FS	FT	GG	JJ	ZZ
STL16	65	14	69	31	M4	93	90	55	30	15	40	24.6	48	18	55	36	70	8
STL25	100	22	117	40.5	M6	146.6	144	72.5	60	15	53	36.2	64	23.2	73.5	50	120	12
STL32	125	25.5	152	49	M6	186.6	184	91	80	15	62	42.2	84	26.2	88	64	160	12
STL40	150	28	152	55	M6	231	226	102	100	20	72	51.6	94	28.5	106.5	78	200	12
STL50	175	33	200	62	M6	270.9	266	117	120	23	85	62.3	110	32.5	128.5	90	240	16

Mid-Section Support

(For versions, see pages 83-84)

Mid-section supports are required from a certain stroke length to prevent excessive deflection and vibration of the linear drive. The diagrams show the maximum permissible unsupported length in relation to loading. A distinction must be drawn between loading 1 and loading 2. Deflection of 0.5 mm max. between supports is permissible.

Note: For speeds $v > 0.5$ m/s the distance between supports should not exceed 1 m.

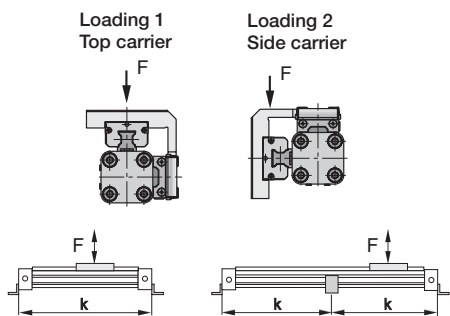

Permissible Unsupported Length STL16 to STL50

Loading 1 Top carrier

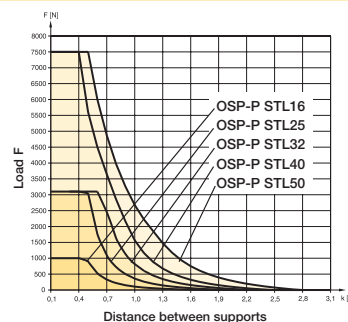

Permissible Unsupported Length STL16 to STL50

Loading 2 Side carrier

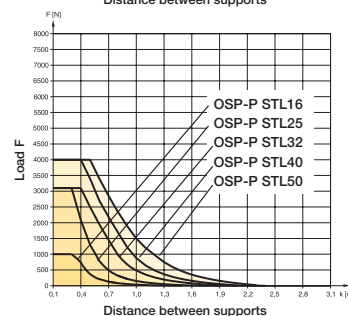

For inventory, lead times, and kit lookup, visit www.pdnplu.com

Rodless Pneumatic Cylinders
OSP-P Series
P1X Series
GDL Series
2002/P120 Series
P55 Electronic & Reed Sensors
Accessories
Part Number Index
Safety Guide, Offer of Sale

Rodless Pneumatic Cylinders
OSP-P Series
P1X Series
GDL Series
2002/P120 Series
P55 Electronic & Reed Sensors
Accessories
Part Number Index
Safety Guide, Offer of Sale

Variable Stop Type VS16 to VS50

The variable stop Type VS provides simple stroke limitation. It can be retrofitted and positioned anywhere along the stroke length.

For every cylinder diameter two types of shock absorber are available – see “Shock Absorber Selection” below.

Mid-section supports and magnetic switches can still be fitted on the same side as the variable stop.

Depending on the application, two variable stops can be fitted if required.

Arrangement with two variable stops

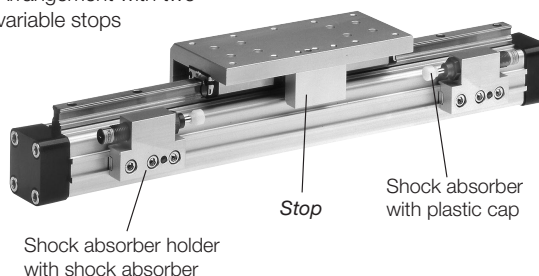

Shock Absorber Selection

The shock absorber is selected in dependence on the mass and speed.

The mass of the carrier itself must be taken into account.

Series OSP-STL16

The values relate to an effective driving force of 78 N (6 bar)

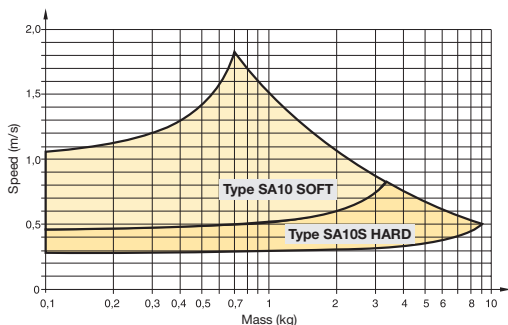

Series OSP-STL25

The values relate to an effective driving force of 250 N (6 bar)

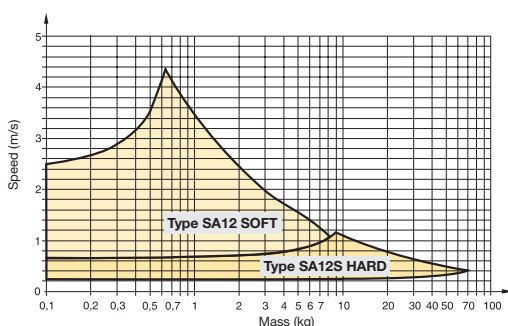

Series OSP-STL32

The values relate to an effective driving force of 420 N (6 bar)

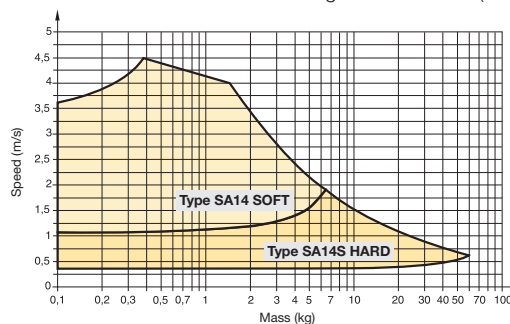

Series OSP-STL40

The values relate to an effective driving force of 640 N (6 bar)

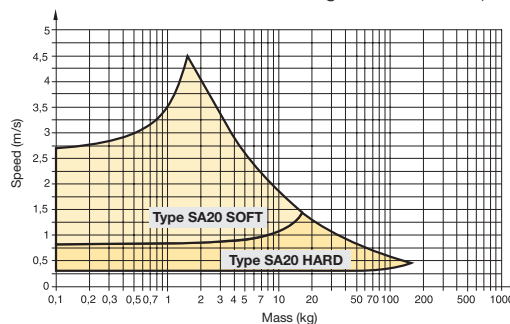

Series OSP-STL50

The values relate to an effective driving force of 1000 N (6 bar)

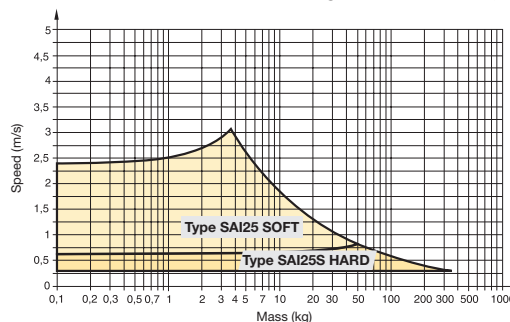

For inventory, lead times, and kit lookup, visit www.pdnplu.com

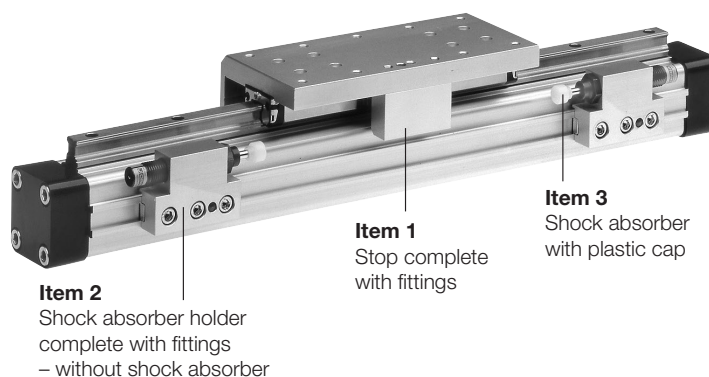
Ordering Information – Variable Stop Type VS16 to VS50

Item	Description	Size	VS16		VS25		VS32		VS40		VS50	
			Type	Part Number	Type	Part Number	Type	Part Number	Type	Part Number	Type	Part Number
1	Stop, complete	-	-	21196FIL	-	21197FIL	-	21198FIL	-	21199FIL	-	21200FIL
2	Shock absorber holder, complete	-	-	21201FIL	-	21202FIL	-	21203FIL	-	21204FIL	-	21205FIL
3 *	Shock absorber, standard	SA10	MC25M	SA12	MC75M-1	SA14	MC150M-B	SA20	MC225M	SAI25	MC600M	
	Shock absorber, version S	SA10S	MC25MH	SA12S	MC75M-2	SA14S	MC150MH-B	SA20S	MC225MH	SAI25S	MC600MH	

* Shock absorber with plastic cap

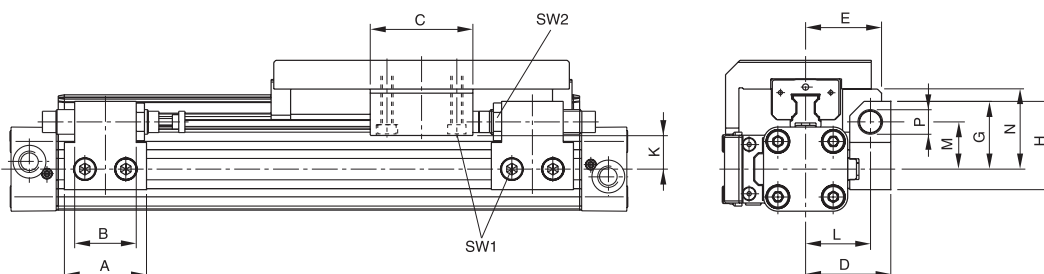
Dimension – Variable Stop Type VS16 to VS50

Series	Type	A	B	C	D	E	G	H	K	L	M	N	P	SW1	SW2
OSP-STL16	VS16	30	14	25	33	30	28	38	16.2	25.5	20.5	30	M10x1	4	12.5
OSP-STL25	VS25	40	30	50	41.5	37	33	43	18	31.5	23	39	M12x1	5	16
OSP-STL32	VS32	60	40	50	45.5	42	35	45	19	35.5	25	48	M14x1.5	5	17
OSP-STL40	VS40	84	52	60	64	59	48	63	25.6	50	34	58.6	M20x1.5	5	24
OSP-STL50	VS50	84	-	60	75	69	55	70	26.9	57	38	66.9	M25x1.5	5	30



 For inventory, lead times, and kit lookup, visit www.pdnplu.com

Features
Recirculating Ball Bearing Guide KF 16 to 50mm bore
Series KF16 to KF50 for Linear-drive

- Series OSP-P CLASSIC

Features

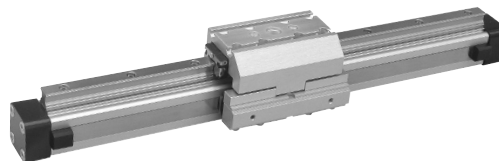
- Anodized aluminum guide carriage, the mounting dimensions correspond to FESTO Type: DGPL-KF
- Polished and hardened steel guide rail
- For high loads in all directions
- High precision
- Integrated wiper system
- Integrated grease nipples
- Any length of stroke up to 3700 mm
- Maximum speed
 KF16, KF40: v = 3 m/s
 KF25, KF32, KF50: v = 5 m/s



Loads, Forces and Moments

The table shows the maximum permissible loads. If multiple moments and forces act upon the cylinder simultaneously, the following equation applies:

$$\frac{M_x}{M_{x\max}} + \frac{M_y}{M_{y\max}} + \frac{M_z}{M_{z\max}} + \frac{F_y}{F_{y\max}} + \frac{F_z}{F_{z\max}} \leq 1$$

The sum of the loads should not exceed >1.

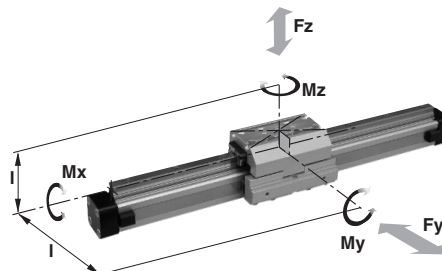
The table shows the maximum permissible values for light, shock-free operation, which must not be exceeded even under dynamic conditions.



Series	For Linear Drive	Max. Moments (Nm)			Max. Load (N)		Mass of Drive with Guide (kg)		Mass * Guide Carriage (kg)	Groove Stone Thread Size
		Mx	My	Mz	Fy	Fz	With 0mm Stroke	Increase per 100mm Stroke		
KF16	OSP-P16	12	25	25	1000	1000	0.558	0.21	0.228	–
KF25	OSP-P25	35	90	90	3100	3100	1.522	0.369	0.607	M5
KF32	OSP-P32	44	133	133	3100	3100	2.673	0.526	0.896	M5
KF40	OSP-P40	119	346	346	4000	7100	4.167	0.701	1.531	M6
KF50	OSP-P50	170	480	480	4000	7500	7.328	0.936	2.760	M8

* Add the mass of the guide carriage to the mass to be cushioned.



For inventory, lead times, and kit lookup, visit www.pdnplu.com

Ordering information for OSP-P rodless KF pneumatic series

1-4	5-6	7	8	9	10	11	12-16	17	18	19	20	21	22	23	24	25	
Bore		Lubrication		Stroke		Piston Mounting		Dovetail Cover		Version		Seals		Endcap Mounting		Porting Configurations	
16 25 32 40 50		0 Standard		xxxxx 5 digits in whole millimeters (ex. 1100mm = 01100)		0 None		0 Standard X Without Cover Rail		0 Standard		0 Standard 1 Fluorocarbon		0 None 4 B1 (25,32) 6 B3 (16) 7 B4 (25,32) 8 B5 (32) 9 C1 (40,50) A C2 (40,50) B C3 (40,50) C C4 (40,50)		0 Standard 1 End Face (16,25,32,40,50) 2 Single End Porting (25,32,40,50) 3 Left Std Pos #2, Right Pos #5 (16,25,32,40,50) 4 Left Pos #5, Right Std Pos #2 (16,25,32,40,50) 6 Single End Porting at #5 (50) A 24VDC VOE Valves (25,32,40,50) B 220VAC VOE Valves (25,32,40,50) C 48VDC VOE Valves (25,32,40,50) E 110VAC VOE Valves (25,32,40,50)	
Piston Style		Hardware		Cushions / Stops		Guides / Brakes		Additional Carriages**		Switches [◊]		Endcap Position		Notes			
C Classic T Tandem Classic		0 Standard		0 Standard 1 Long Cushions (25,32,40) 2 VS Soft Left 3 VS Hard Left 4 VS Soft Right 5 VS Hard Right 6 VS Soft Both Sides 7 VS Hard Both Sides		C KF Guide		0 None C KF <small>** Note: Available on tandem piston only</small>		0 None 1 Normally Open Reed Switch (16 thru 50) 2 Normally Closed Reed Switch (16 thru 50) 3 PNP Hall Sensor w/Extension Cables (16 thru 50) 4 NPN Hall Sensor w/Extension Cables (16 thru 50) <small>◊ Note: 2 switches will be supplied. For different quantity, please order as a separate line item.</small>		0 Both Pos #2 1 Both Pos #3 2 Both Pos #4 3 Both Pos #1 4 Left #3 / Right #2 5 Left #4 / Right #2 6 Left #1 / Right #2 7 Left #2 / Right #3 8 Left #4 / Right #3 9 Left #1 / Right #3 A Left #2 / Right #4 B Left #3 / Right #4 C Left #1 / Right #4 D Left #2 / Right #1 E Left #3 / Right #1 F Left #4 / Right #1		Note: Comes in pairs			

Note: Position #2 is the standard location.

Rodless Pneumatic Cylinders
OSP-P Series
P1X Series
GDL Series
2002/P120 Series
P55 Electronic & Reed Sensors
Accessories
Part Number Index
Safety Guide, Offer of Sale



For inventory, lead times, and kit lookup, visit www.pdnplu.com

Series OSP-P KF16 to KF50

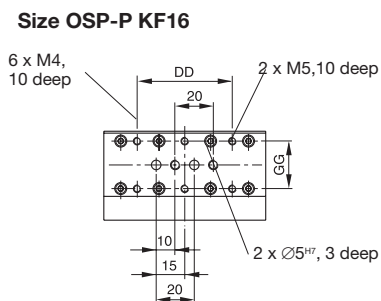
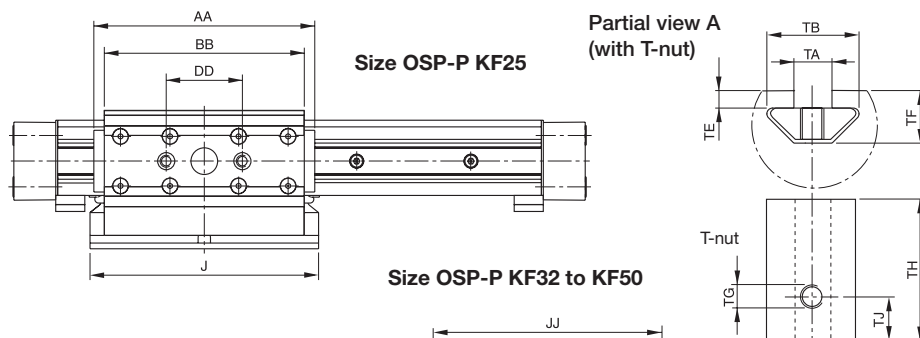
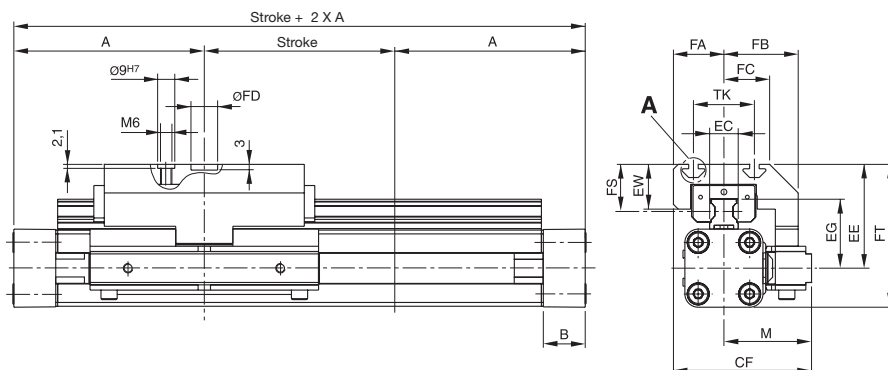

Dimension (mm) Series OSP-P KF16, KF25, KF32, KF40, KF50

Series	A	B	J	AA	BB	CF	DD	EC	EE	EG	EW	JJ	GG	M
KF16	65	14	76	93	85	48	50	15	41	24.6	10	-	25	30
KF25	100	22	120	120.2	105	72.5	40	15	54.5	36.2	23.5	-	-	46
KF32	125	25.5	160	146.2	131	93.8	40	15	60.5	42.2	23.5	-	20	59.8
KF40	150	28	150	188.5	167	103.3	40	20	69.5	51.6	26.5	120	20	60.8
KF50	175	33	180	220.2	202	121	40	23	90.5	62.3	32.5	120	40	69

Series	FA	FB	FC	FD	FT	FS	TA	TB	TE	TF	TG	TH	TJ	TK
KF16	17.7	29	16.5	-	56	19	-	-	-	-	-	-	-	-
KF25	26.5	39	24	14 G7	75	24.7	5	12.1	2.3	6.9	M5	11.5	4	32
KF32	34	53.8	34	25 G7	86.5	24.7	5	12.1	1.8	6.4	M5	11.5	4	47
KF40	42.5	56.8	41	25 G7	104	26	6	12.8	1.8	8.4	M6	17	5.5	55
KF50	52	65	50	25 G7	134	38	8	21.1	4.5	12.5	M8	23	7.5	72



For inventory, lead times, and kit lookup, visit www.pdnplu.com

Mid-Section Support

(For versions, see pages 84-85)

Mid-section supports are required from a certain stroke length to prevent excessive deflection and vibration of the linear drive. The diagrams show the maximum permissible unsupported length in relation to loading. A distinction must be drawn between loading 1 and loading 2.

Deflection of 0.5 mm max. between supports is permissible.

Note: For speeds $v > 0.5$ m/s the distance between supports should not exceed 1 m.

**Permissible Unsupported Length OSP-P KF16 to KF50
 Loading 1 – Top carrier**

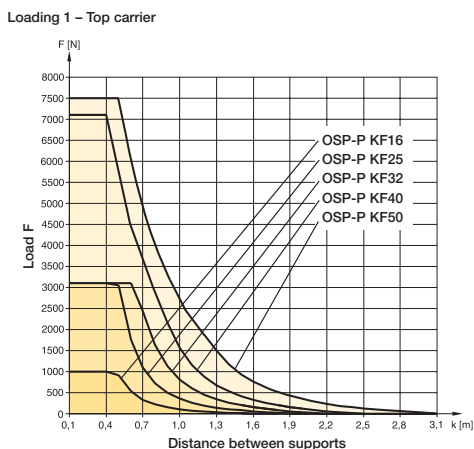

**Permissible Unsupported Length OSP-P KF16 to KF50
 Loading 2 – Side carrier**

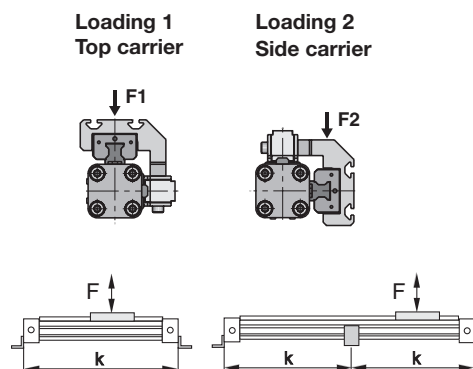
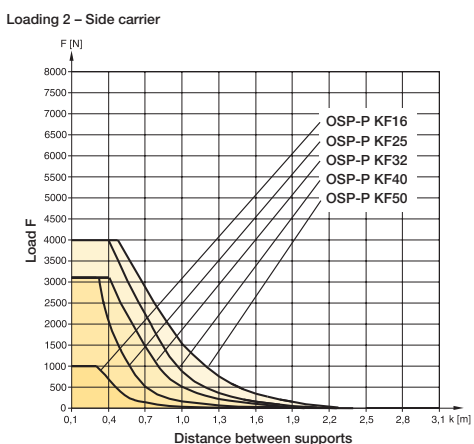

Rodless Pneumatic Cylinders
OSP-P Series
P1X Series
GDL Series
2002/P120 Series
P5S Electronic & Reed Sensors
Accessories
Part Number Index
Safety Guide, Offer of Sale



For inventory, lead times, and kit lookup, visit www.pdnplu.com

Rodless Pneumatic Cylinders
OSP-P Series
P1X Series
GDL Series
2002/P120 Series
P5S Electronic & Reed Sensors
Accessories
Part Number Index
Safety Guide, Offer of Sale

Variable Stop Type VS16 to VS50

The variable stop Type VS provides simple stroke limitation. It can be retrofitted and positioned anywhere along the stroke length. For every cylinder diameter two types of shock absorber are available – see “Shock Absorber Selection” below.

Mid-section supports and magnetic switches can still be fitted on the same side as the variable stop.

Depending on the application, two variable stops can be fitted if required.

Arrangement with two variable stops

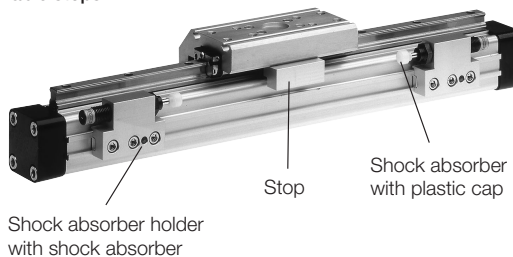

Shock Absorber Selection

The shock absorber is selected in dependence on the mass and speed.

The mass of the carrier itself must be taken into account.

Series OSP-KF16

The values relate to an effective driving force of 78 N (6 bar)

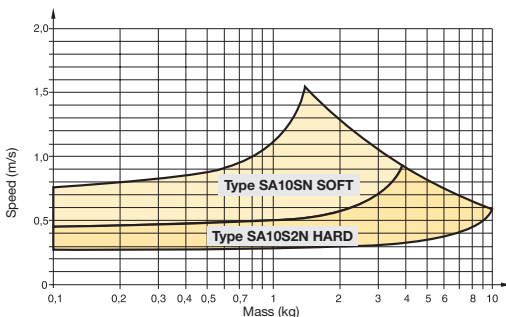

Series OSP-KF25

The values relate to an effective driving force of 250 N (6 bar)

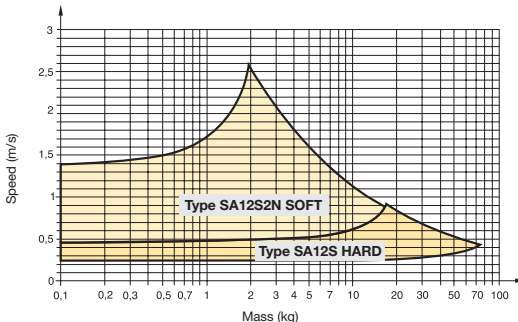

Series OSP-KF32

The values relate to an effective driving force of 420 N (6 bar)

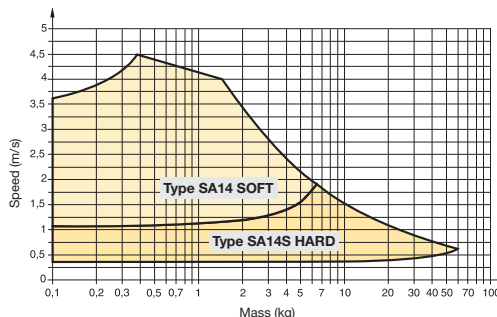

Series OSP-KF40

The values relate to an effective driving force of 640 N (6 bar)

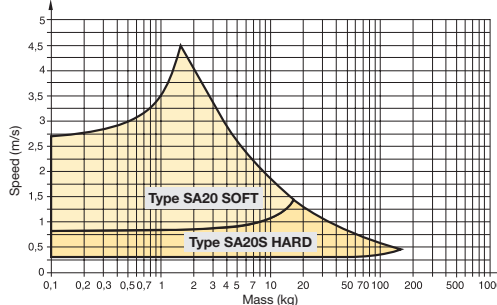

Series OSP-KF50

The values relate to an effective driving force of 1000 N (6 bar)

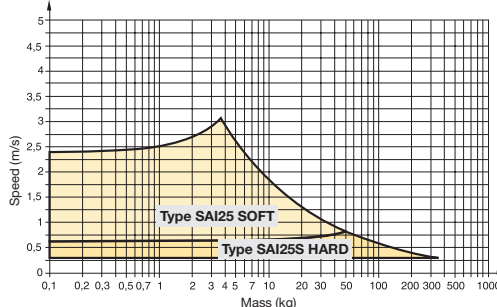

For inventory, lead times, and kit lookup, visit www.pdnplu.com

Ordering Information – Variable Stop Type VS16 to VS50

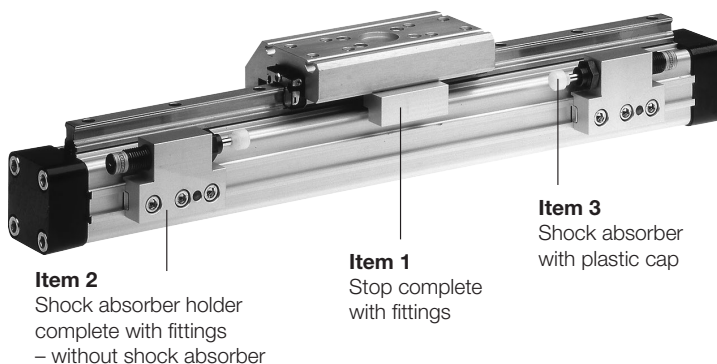

Item	Description	VS16		VS25		VS32		VS40		VS50	
		Type	Part Number	Type	Part Number	Type	Part Number	Type	Part Number	Type	Part Number
1	Stop, complete	-	21186FIL	-	21187FIL	-	21188FIL	-	21189FIL	-	21290FIL
2	Shock absorber holder, complete	-	21201FIL	-	21202FIL	-	21203FIL	-	21204FIL	-	21205FIL
3*	Shock absorber, standard	SA10SN	MC25M	SA12S2N	MC75M-1	SA14	MC150M-B	SA20	MC225M	SAI25	MC600M
	Shock absorber, version S	SA10S2N	MC25MH	SA12S	MC75M-2	SA14S	MC150MH-B	SA20S	MC225MH	SAI25S	MC600MH

* Shock absorber with plastic cap

Dimension – Variable Stop Type VS16 to VS50

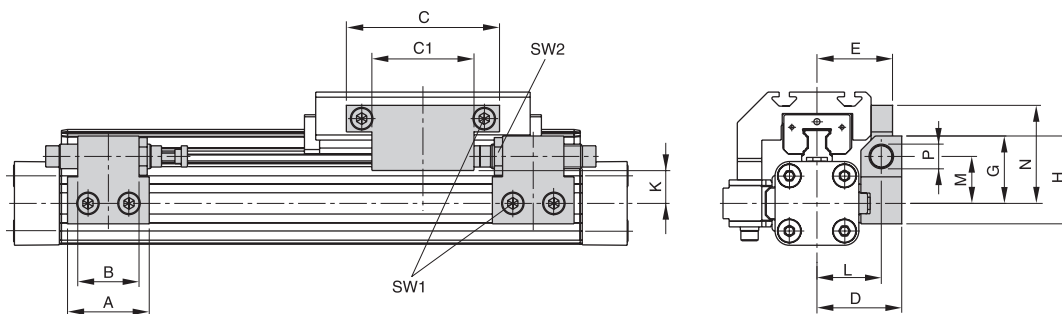

Dimension (mm) – Variable Stop Type VS16 to VS50

Series	Type	A	B	C	C1	D	E	G	H	K	L	M	N	P	SW1	SW2
OSP-KF16	VS16	30	14	50	25	33	29.7	28	38	16.2	25.5	20.5	40.5	M10 x 1	4	12.5
OSP-KF25	VS25	40	30	75	50	41.5	37	33	43	18	31.5	23	48	M12 x 1	5	16
OSP-KF32	VS32	60	40	50	-	45.5	41.5	35	45	19	35.5	25	37	M14 x 1.5	5	17
OSP-KF40	VS40	84	52	60	-	64	59	48	63	25.5	50	34	43	M20 x 1.5	5	24
OSP-KF50	VS50	84	-	60	-	75	69	55	70	26.9	57	38	58	M25 x 1.5	5	30



For inventory, lead times, and kit lookup, visit www.pdnplu.com

Rodless Pneumatic Cylinders
OSP-P Series
P1X Series
GDL Series
2002/P120 Series
P55 Electronic & Reed Sensors
Accessories
Part Number Index
Safety Guide, Offer of Sale

End Cap Mounting – Type HP Ø 25 to 50mm (correspond to FESTO dimensions)

For Linear-drive with Recirculating Ball Bearing Guide

- Series OSP-P KF

On the end-face of each end cap there are four threaded holes for mounting the actuator.

Material:

- Anodized aluminum.
- The mountings are supplied in pairs.

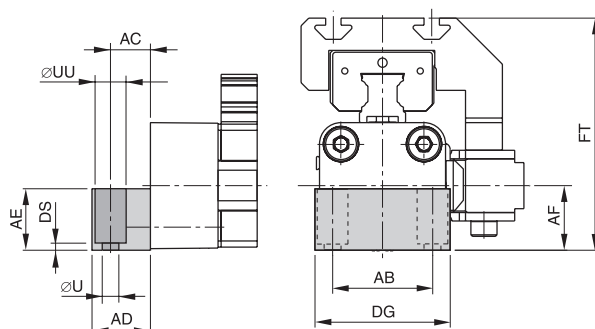

Note: Correspond to FESTO DGPL-KF, when the End Cap Mountings HP are mounted on the opposite side to the carriage (see drawing)

Dimension (mm)

Series	ØU	AB	AC	AD	AE	AF	DG	DS	FT	ØUU	Part number
HP25	5.5	32.5	13	19	20	21	44	2	75.5	10	21107FIL
HP32	6.6	38	17	24	24	27	52	3	87.5	11	21108FIL
HP40	6.6	45	17.5	24	24	35	68	2	104.5	11	21109FIL
HP50	9	65	25	35	35	48	86	6	138.5	15	21110FIL

 For inventory, lead times, and kit lookup, visit www.pdnplu.com

Features

Heavy Duty Guide HD 25 to 50mm bore

Series HD 25 to 50 for Linear-drive

- Series OSP-P

OSP

Features

- Guide system: 4-row recirculating ball bearing guide
- Polished and hardened steel guide rail
- For highest loads in all directions
- Highest precision
- Integrated wiper system
- Integrated grease nipples
- Any lengths of stroke up to 3700 mm (longer strokes on request)
- Anodized aluminum guide carriage – dimensions compatible with OSP guide GUIDELINE
- Maximum speed $v = 5 \text{ m/s}$

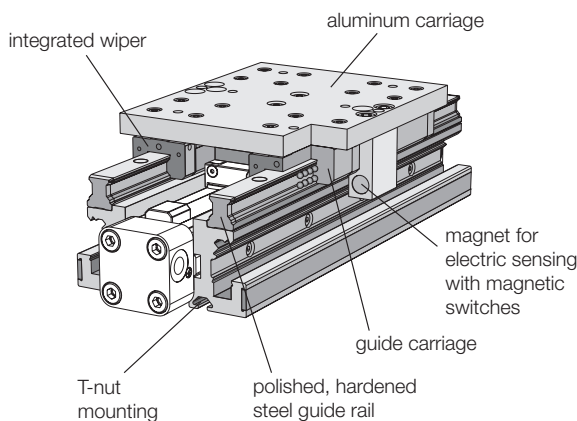
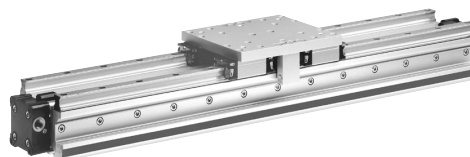

Loads, Forces and Moments

The table shows the maximum permissible loads. If multiple moments and forces act upon the cylinder simultaneously, the following equation applies:

$$\frac{M_x}{M_{x\max}} + \frac{M_y}{M_{y\max}} + \frac{M_z}{M_{z\max}} + \frac{F_y}{F_{y\max}} + \frac{F_z}{F_{z\max}} \leq 1$$

The sum of the loads should not exceed >1.

The table shows the maximum permissible values for light, shock-free operation which must not be exceeded even under dynamic conditions.

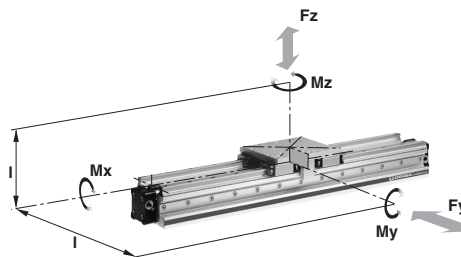

Series	For Linear Drive	Max. Moments (Nm)			Max. Loads (N)		Mass of the Linear Drive with Guide (kg)		
		Mx	My	Mz	Fz	Fy	With 0mm Stroke	Increase per 100mm Stroke	Mass * Guide Carriage (kg)
HD25	OSP-P25	260	320	320	6000	6000	3.065	0.924	1.289
HD32	OSP-P32	285	475	475	6000	6000	4.308	1.112	1.367
HD40	OSP-P40	800	1100	1100	15000	15000	7.901	1.748	2.712
HD50	OSP-P50	1100	1400	1400	18000	18000	11.648	2.180	3.551

*Add the mass of the guide carriage to the mass to be cushioned.

Rodless Pneumatic Cylinders
OSP-P Series
P1X Series
GDL Series
2002/P120 Series
P55 Electronic & Reed Sensors
Accessories
Part Number Index
Safety Guide, Offer of Sale



For inventory, lead times, and kit lookup, visit www.pdnplu.com

Ordering Information

Ordering information for OSP-P rodless HD pneumatic series

- Rodless Pneumatic Cylinders
- OSP-P Series
- P1X Series
- GDL Series
- 2002/P120 Series
- P55 Electronic & Reed Sensors
- Accessories
- Part Number Index
- Safety Guide, Offer of Sale

1-4	5-6	7	8	9	10	11	12-16	17	18	19	20	21	22	23	24	25					
OSPP	25	0	1	0	0	0	01100	0	0	0	D	0	0	1	0	0					
Bore		Seals		Lubrication		Stroke		Piston Mounting		Cushions / Stops		Dovetail Cover		Version		Switches [◇]					
25 32 40 50		0 Standard 1 Fluorocarbon		0 Standard		xxxxx 5 digits in whole millimeters (ex. 1100mm = 01100)		0 None		0 Standard 1 Long Cushions (25,32,40) 2 VS Soft Left 3 VS Hard Left 4 VS Soft Right 5 VS Hard Right 6 VS Soft Both Sides 7 VS Hard Both Sides		0 Standard X Without Cover Rail		0 Standard		0 None 1 Normally Open Reed Switch (25 thru 50) 2 Normally Closed Reed Switch (25 thru 50) 3 PNP Hall Sensor w/Extension Cables (25 thru 50) 4 NPN Hall Sensor w/Extension Cables (25 thru 50)					
Piston Style		Hardware		Porting Configurations		Endcap Position		Guides / Brakes		Additional Carriages**		Endcap Mounting									
0 Standard 1 Tandem		0 Standard		0 Standard 1 End Face (25,32,40,50) 2 Single End Porting (25,32,40,50) 3 Left Std Pos #2, Right Pos #5 (25,32,40,50) 4 Left Pos #5, Right Std Pos #2 (25,32,40,50) 6 Single End Porting at #5 (50) A 24VDC VOE Valves (25,32,40,50) B 220VAC VOE Valves (25,32,40,50) C 48VDC VOE Valves (25,32,40,50) E 110VAC VOE Valves (25,32,40,50)		0 Standard		0 Both Pos #2 1 Both Pos #3 2 Both Pos #4 3 Both Pos #1 4 Left #3 / Right #2 5 Left #4 / Right #2 6 Left #1 / Right #2 7 Left #2 / Right #3 8 Left #4 / Right #3 9 Left #1 / Right #3 A Left #2 / Right #4 B Left #3 / Right #4 C Left #1 / Right #4 D Left #2 / Right #1 E Left #3 / Right #1 F Left #4 / Right #1		D Heavy Duty		0 None D Heavy Duty Guide		0 None		0 None					
				Note: Single end porting on 16mm bore, then end caps cannot be rotated.						** Note: Available on tandem piston only											

Note: Position #2 is the standard location.



For inventory, lead times, and kit lookup, visit www.pdnplu.com

Series OSP-P HD 25 to 50mm

Note: The HD heavy duty guide must be mounted on a flat surface for its entire length.

If T-grooves or T-bolts are used, the distance between them should not exceed 100 mm.

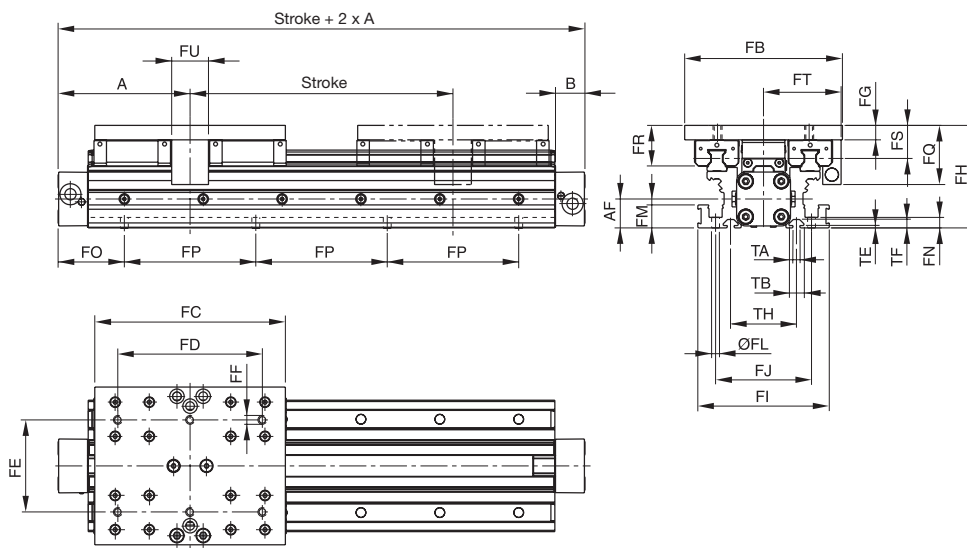

**Variable Stop
 Type VS25 to VS50**

The variable stop provides simple stroke limitation and can be supplied mounted on the right or left, as required.

For further information see Variable Stop page 75.

For shock absorber selection see page 62.

**Incremental displacement
 measuring system
 Sensoflex**

Series SFI-plus can be supplied mounted on the right or left, as required.

For further information see page 87.

**Arrangement of magnetic
 switches:**

Magnetic switches can be fitted anywhere on either side.

For further information see following data sheets:

Magnetic Switches see pages 161-170.

Dovetail Cover see page 85.

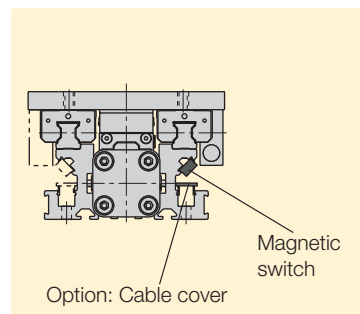
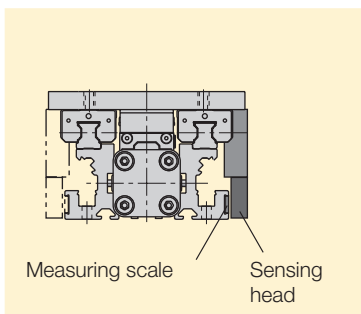
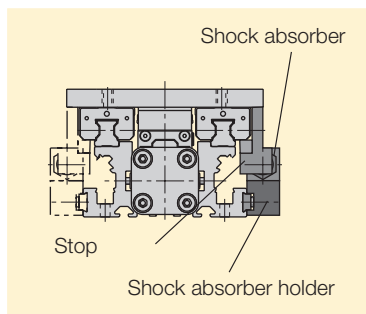

For inventory, lead times, and kit lookup, visit www.pdnplu.com

Rodless Pneumatic Cylinders
OSP-P Series
P1X Series
GDL Series
2002/P120 Series
P55 Electronic & Reed Sensors
Accessories
Part Number Index
Safety Guide, Offer of Sale

Catalog 0961-1
Dimensional Data

Rodless Pneumatic Cylinders
OSP-P Series, Heavy Duty Guide HD

Series	A	B	AF	FB	FC	FD	FE	FF	FG	FH	FI	FJ	ØFL
HD25	100	22	22	120	145	110	70	M6	11	78	100	73	6
HD32	125	25.5	30	120	170	140	80	M6	11	86	112	85	6
HD40	150	28	38	160	180	140	110	M8	14	108	132	104	7.5
HD50	175	33	48	180	200	160	120	M8	14	118	150	118	7.5

Series	FM	FN	FP	FQ	FR	FS	FT	FU	TA	TB	TE	TF	TH
HD25	17.5	8	100	45	31	25	59	28	5.2	11.5	1.8	6.4	50
HD32	17.5	8	100	45	31	25	63	30	5.2	11.5	1.8	6.4	60
HD40	22	10	100	58	40	31.5	76	30	8.2	20	4.5	12.3	66
HD50	22	10	100	58	44	35.5	89	30	8.2	20	4.5	12.3	76

Note:

The dimension FO is derived from the last two digits of the stroke:

For a cylinder OSP-P25 the adjacent table indicates that for x = 25 mm:

FO = 62.5 mm

Example:



X	FO OSP-P				X	FO OSP-P				X	FO OSP-P			
	HD25	HD32	HD40	HD50		HD25	HD32	HD40	HD50		HD25	HD32	HD40	HD50
00	50.0	75.0	50.0	75.0	34	67.0	42.0	67.0	92.0	68	34.0	59.0	84.0	59.0
01	50.5	75.5	50.5	75.5	35	67.5	42.5	67.5	92.5	69	34.5	59.5	84.5	59.5
02	51.0	76.0	51.0	76.0	36	68.0	43.0	68.0	93.0	70	35.0	60.0	85.0	60.0
03	51.5	76.5	51.5	76.5	37	68.5	43.5	68.5	93.5	71	35.5	60.5	85.5	60.5
04	52.0	77.0	52.0	77.0	38	69.0	44.0	69.0	94.0	72	36.0	61.0	86.0	61.0
05	52.5	77.5	52.5	77.5	39	69.5	44.5	69.5	94.5	73	36.5	61.5	86.5	61.5
06	53.0	78.0	53.0	78.0	40	70.0	45.0	70.0	95.0	74	37.0	62.0	87.0	62.0
07	53.5	78.5	53.5	78.5	41	70.5	45.5	70.5	95.5	75	37.5	62.5	87.5	62.5
08	54.0	79.0	54.0	79.0	42	71.0	46.0	71.0	96.0	76	38.0	63.0	88.0	63.0
09	54.5	79.5	54.5	79.5	43	71.5	46.5	71.5	96.5	77	38.5	63.5	88.5	63.5
10	55.0	80.0	55.0	80.0	44	72.0	47.0	72.0	97.0	78	39.0	64.0	89.0	64.0
11	55.5	80.5	55.5	80.5	45	72.5	47.5	72.5	97.5	79	39.5	64.5	89.5	64.5
12	56.0	81.0	56.0	81.0	46	73.0	48.0	73.0	98.0	80	40.0	65.0	90.0	65.0
13	56.5	81.5	56.5	81.5	47	73.5	48.5	73.5	98.5	81	40.5	65.5	90.5	65.5
14	57.0	82.0	57.0	82.0	48	74.0	49.0	74.0	99.0	82	41.0	66.0	91.0	66.0
15	57.5	82.5	57.5	82.5	49	74.5	49.5	74.5	99.5	83	41.5	66.5	91.5	66.5
16	58.0	83.0	58.0	83.0	50	75.0	50.0	75.0	100.0	84	42.0	67.0	92.0	67.0
17	58.5	83.5	58.5	83.5	51	75.5	50.5	75.5	100.5	85	42.5	67.5	92.5	67.5
18	59.0	84.0	59.0	84.0	52	76.0	51.0	76.0	101.0	86	43.0	68.0	93.0	68.0
19	59.5	84.5	59.5	84.5	53	76.5	51.5	76.5	101.5	87	43.5	68.5	93.5	68.5
20	60.0	85.0	60.0	85.0	54	77.0	52.0	77.0	102.0	88	44.0	69.0	94.0	69.0
21	60.5	85.5	60.5	85.5	55	77.5	52.5	77.5	102.5	89	44.5	69.5	94.5	69.5
22	61.0	86.0	61.0	86.0	56	78.0	53.0	78.0	103.0	90	45.0	70.0	95.0	70.0
23	61.5	86.5	61.5	86.5	57	78.5	53.5	78.5	103.5	91	45.5	70.5	95.5	70.5
24	62.0	87.0	62.0	87.0	58	79.0	54.0	79.0	104.0	92	46.0	71.0	96.0	71.0
25	62.5	87.5	62.5	87.5	59	79.5	54.5	79.5	104.5	93	46.5	71.5	96.5	71.5
26	63.0	88.0	63.0	88.0	60	80.0	55.0	80.0	105.0	94	47.0	72.0	97.0	72.0
27	63.5	88.5	63.5	88.5	61	80.5	55.5	80.5	105.5	95	47.5	72.5	97.5	72.5
28	64.0	89.0	64.0	89.0	62	81.0	56.0	81.0	106.0	96	48.0	73.0	98.0	73.0
29	64.5	89.5	64.5	89.5	63	81.5	56.5	81.5	106.5	97	48.5	73.5	98.5	73.5
30	65.0	90.0	65.0	90.0	64	82.0	57.0	82.0	107.0	98	49.0	74.0	99.0	74.0
31	65.5	90.5	65.5	90.5	65	82.5	57.5	82.5	107.5	99	49.5	74.5	99.5	74.5
32	66.0	91.0	66.0	91.0	66	83.0	58.0	83.0	108.0					
33	66.5	91.5	66.5	91.5	67	83.5	58.5	83.5	108.5					



For inventory, lead times, and kit lookup, visit www.pdnplu.com

Ordering Information – Variable Stop Type VS25 to VS50

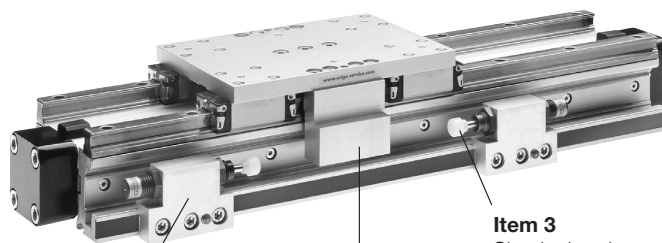

Item 2
 Shock absorber holder
 complete with fittings
 – without shock absorber

Item 1
 Stop complete
 with fittings

Item 3
 Shock absorber
 with plastic cap

Item	Description	VS25		VS32		VS40		VS50	
		Type	Part Number	Type	Part Number	Type	Part Number	Type	Part Number
1	Stop, complete	–	21257FIL	–	21158FIL	–	21159FIL	–	21260FIL
2	Shock absorber holder, complete	–	21202FIL	–	21203FIL	–	21204FIL	–	21205FIL
3 *	Shock absorber, standard	SA12	MC75M-1	SA14	MC150M-B	SA20	MC225M	SAI25	MC600M
	Shock absorber, version S	SA12S	MC75M-2	SA14S	MC150MH-B	SA20S	MC225MH	SAI25S	MC600MH

* Shock absorber with plastic cap

Dimension – Variable Stop Type VS16 to VS50

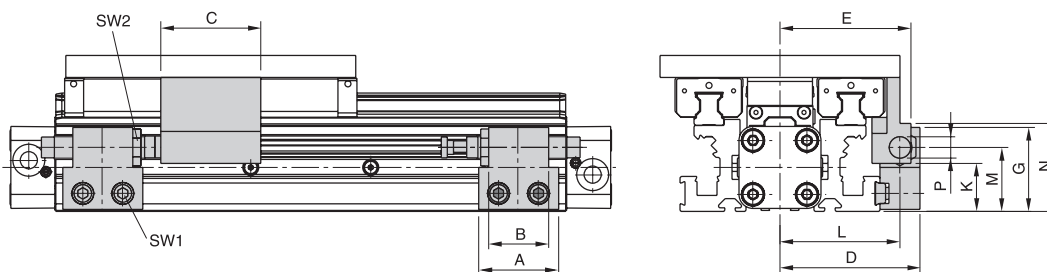

Series	Type	A	B	C	D	E	G	K	L	M	N	P	SW1	SW2
OSP-HD25	VS25	40	30	50	70	65.5	42	26	60	32	42	M12 x 1	5	16
OSP-HD32	VS32	60	40	54	73	71	44	28	63	34	53	M14 x 1.5	5	17
OSP-HD40	VS40	84	52	55	96	92	59	35	82	45	61	M20 x 1.5	5	24
OSP-HD50	VS50	84	-	60	107	105	66	37	89	49	66	M25 x 1.5	5	30

Shock Absorber Selection

For shock absorber selection in dependence on mass and speed see page 68.



For inventory, lead times, and kit lookup, visit www.pdnplu.com

Rodless Pneumatic Cylinders
 OSP-P Series
 P1X Series
 GDL Series
 2002/P120 Series
 P55 Electronic & Reed Sensors
 Accessories
 Part Number Index
 Safety Guide, Offer of Sale

Technical Data, Intermediate Stop
Intermediate Stop Module – 25mm only

The intermediate stop module ZSM allows the guide carriage to stop at any desired intermediate positions with high accuracy. It can be retrofitted. Depending on the application, i.e. the number of intermediate stops, one or more intermediate position stops can be used.

The intermediate position stops can be retracted and extended without the need for the guide carriage to be moved back out of position.

Therefore the guide carriage can be made to stop at the defined intermediate positions in any order.

Intermediate stop module ZSM:

- Allows stopping at any intermediate positions
- Intermediate position stops can be located steplessly anywhere along the whole stroke length
- Movement to the next position without reverse stroke
- Compact unit
- Cost-effective positioning module without electrical or electronic components
- Option: end stop with fine adjustment

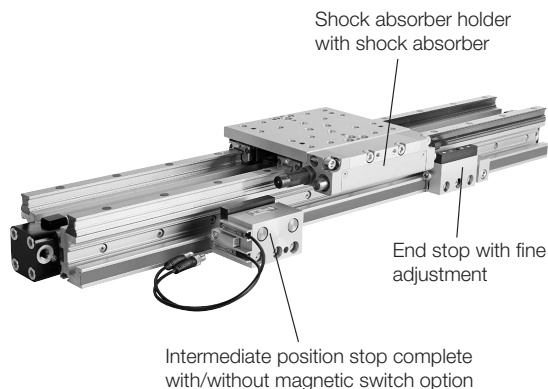
Operating information

Operating pressure:	87 to 116 PSIG (4 to 8 bar)
Temperature range:	14°F to 158°F (-10°C to 70°C)
Intermediate position grid:	85mm

Shock Absorber
Type SA14S

The values relate to an effective driving force of 250 N (6 bar)

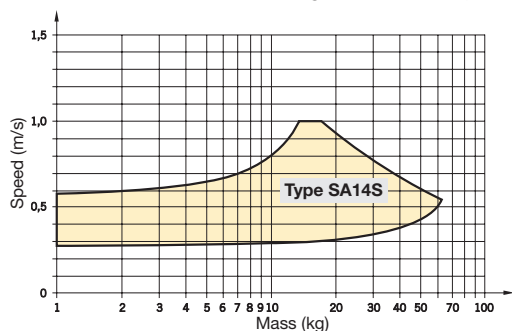

Rodless Pneumatic Cylinders

OSP-P Series

P1X Series

GDL Series

2002/P120 Series

P5S Electronic & Reed Sensors

Accessories

Part Number Index

Safety Guide, Offer of Sale



For inventory, lead times, and kit lookup, visit www.pdnplu.com

Intermediate Stop Module – Type ZSM..HD

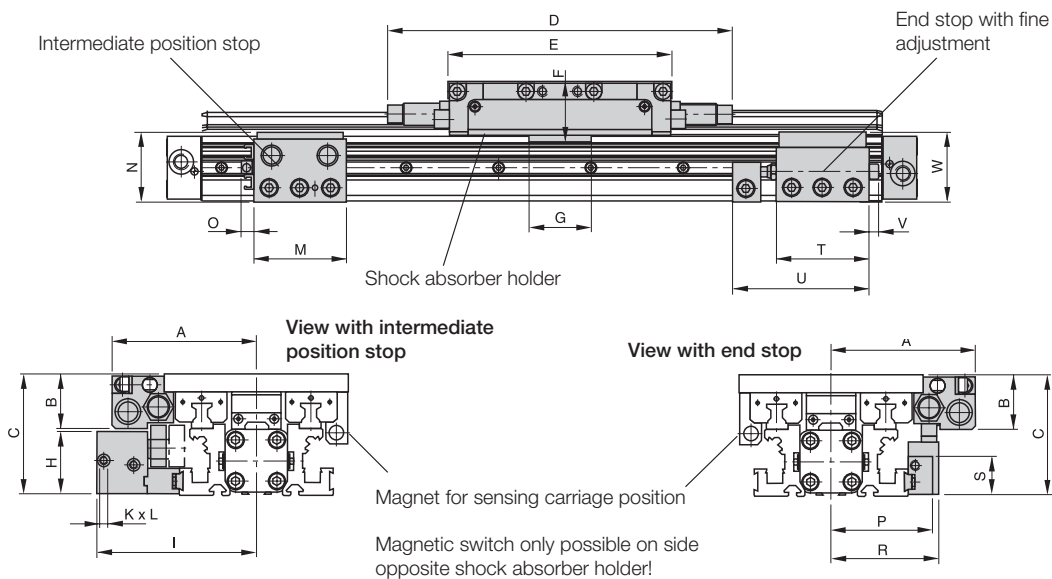

Dimension (mm)

Series	A	B	C	D	E	F	G	H	I	K	L	M	N	O	P	R	S	T	U	V	W
ZSM25	94	35	78	224	145	39	40	41	104	M5	5	60	45	8	66	70	26	60	93	6	45

Shock Absorber Arrangement in Dependence on Direction of Movement

From right to left

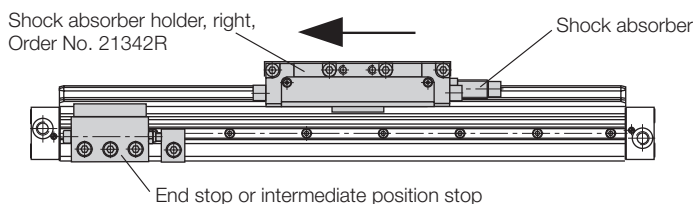

In both directions

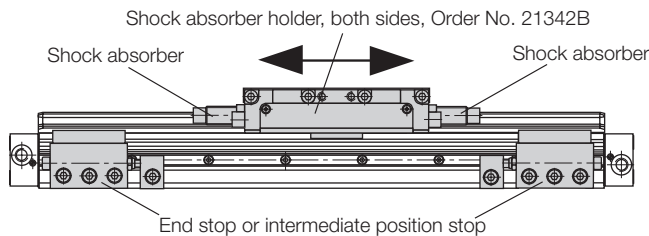

From left to right

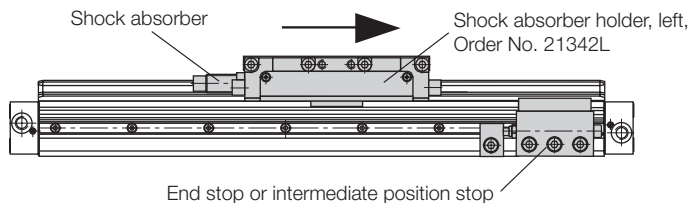

Rodless Pneumatic Cylinders
OSP-P Series
P1X Series
GDL Series
2002/P120 Series
P5S Electronic & Reed Sensors
Accessories
Part Number Index
Safety Guide, Offer of Sale



For inventory, lead times, and kit lookup, visit www.pdnplu.com

Order Instructions – intermediate Stop Module Type ZSM..HD

Illustration shows version with shock absorber holder for movement in both directions and magnetic switch option with T-slot switches.

Note: For movement onwards from the intermediate position, the intermediate position stop must advance.

The intermediate position stop can only advance if both cylinder chambers of the OSP-P cylinder are pressurized.

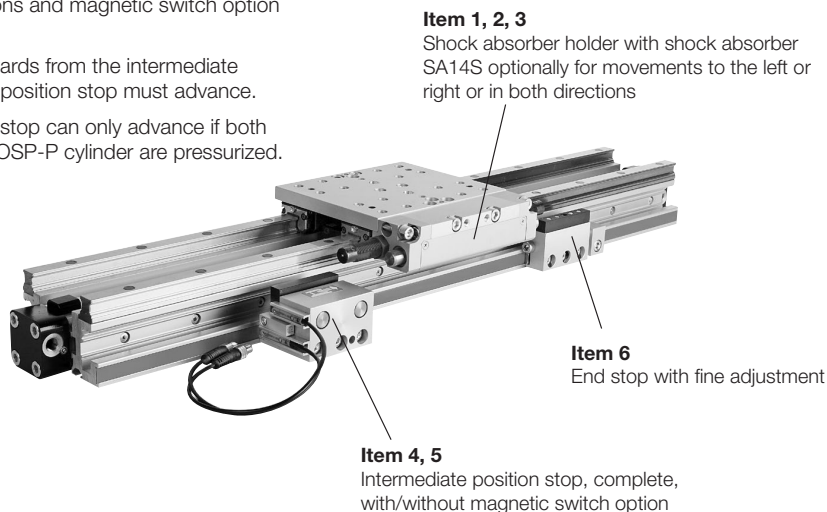

Order instructions – intermediate stop module Type ZSM..HD 25mm Only

For Intermediate Stop Module	Item	Description	Part Number
ZSM25HD	1*	Shock absorber holder with shock absorber SA14S, both sides	21342BFIL
ZSM25HD	2*	Shock absorber holder with shock absorber SA14S, left	21342LFIL
ZSM25HD	3*	Shock absorber holder with shock absorber SA14S, right	21342RFIL
ZSM25HD	4	Intermediate position stop complete, without magnetic switch option	21343FIL
ZSM25HD	5	Intermediate position stop complete, with magnetic switch option	21344FIL
ZSM25HD	6	End stop with fine adjustment	21346FIL

* The shock absorbers are installed in the shock absorber holder and adjusted in our workshop.

Rodless Pneumatic Cylinders
OSP-P Series
P1X Series
GDL Series
2002/P120 Series
P5S Electronic & Reed Sensors
Accessories
Part Number Index
Safety Guide, Offer of Sale



For inventory, lead times, and kit lookup, visit www.pdnplu.com

Mountings for Linear Drives fitted with OSP-Guides

For Linear-drive

- Series OSP-P

OSP

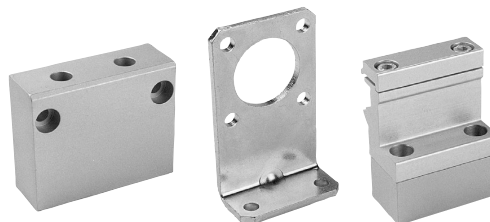

Type – OSP Guides

Mounting Type	Type	SLIDELINE PROLINE MULTIBRAKE							POWERSLIDE									
		16†	25	32	40	50	63†	80†	16/ 25	25/ 25	25/ 35	25/ 44	32/ 35	32/ 44	40/ 44	40/ 60	50/ 60	50/ 76
 End cap mounting	Type A1	X							X									
	Type A2	O	O	O														
	Type A3										O	O		O				
 End cap mounting, reinforced	Type B1		X	X						X	X	X	X	X				
	Type B3								O									
	Type B4											O		O				
	Type B5																	
 End cap mounting	Type C1				X	X	X	X						X	X	X	X	
	Type C2				O	O												
	Type C3						O	O						O		O		
	Type C4														O		O	
 Mid-Section support, small Mid-Section support, wide	Type D1	X	X	X	X	X	X	X	X	X	X	X	X	X	X	X	X	
	Type E1	X	X	X	X	X	X	X	X	X	X	X	X	X	X	X	X	
	Type E2	O	O	O	O	O												
	Type E3						O	O	O	O	O		O		O		O	
	Type E4											O		O		O		
Type E5																		

- X** = carriage mounted in top (12 o'clock position)
- O** = carriage mounted in lateral (3 or 9 o'clock position)
- = available components
- †** = not available for all sizes

Rodless Pneumatic Cylinders
OSP-P Series
P1X Series
GDL Series
2002/P120 Series
P55 Electronic & Reed Sensors
Accessories
Part Number Index
Safety Guide, Offer of Sale



For inventory, lead times, and kit lookup, visit www.pdnplu.com

End Cap Mountings

Four internal screw threads are located in the end faces of all OSP actuators for mounting the drive unit. End cap mountings may be secured across any two adjacent screws.

Material:

- Series OSP-16, 25, 32: Galvanized steel
- Series OSP-40, 50, 63, 80: Anodized aluminum

The mountings are supplied in pairs.

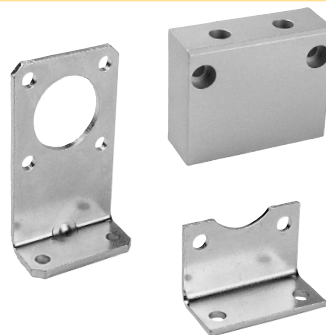
Dimension (mm)
AE and AF (Dependent on the mounting type)

Mount. type	Dimensions AE for Size							AF for Size						
	16	25	32	40	50	63	80	16	25	32	40	50	63	80
A1	12.5	18	20	-	-	-	-	15	22	30	-	-	-	-
A2	27.5	33	34	-	-	-	-	30	37	44	-	-	-	-
A3	-	45	42	-	-	-	-	-	49	52	-	-	-	-
B1	-	42	55	-	-	-	-	22	30	-	-	-	-	-
B3	55	-	-	-	-	-	-	42	-	-	-	-	-	-
B4	-	80	85	-	-	-	-	60	60	-	-	-	-	-
B5	-	-	90	-	-	-	-	65	-	-	-	-	-	-
C1	-	-	-	24	30	40	50	-	-	-	38	48	57	72
C2	-	-	-	37	39	-	-	-	-	-	51	57	-	-
C3	-	-	-	46	54	76	88	-	-	-	60	72	93	110
C4	-	-	-	56	77	-	-	-	-	-	70	95	-	-

Series	E	øU	AB	AC	AD	CL	DG
OSP-P16	18	3.6	18	10	14	1.6	26
OSP-P25	27	5.8	27	16	22	2.5	39
OSP-P32	36	6.6	36	18	26	3	50
OSP-P40	54	9	30	12.5	24	-	68
OSP-P50	70	9	40	12.5	24	-	86
OSP-P63	78	11	48	15	30	-	104
OSP-P80	96	14	60	17.5	35	-	130

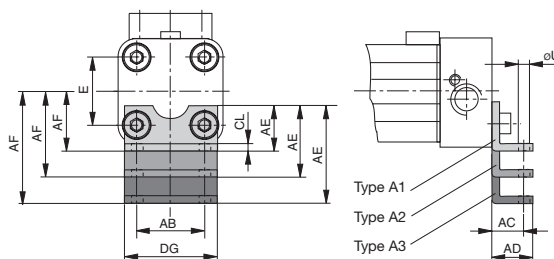
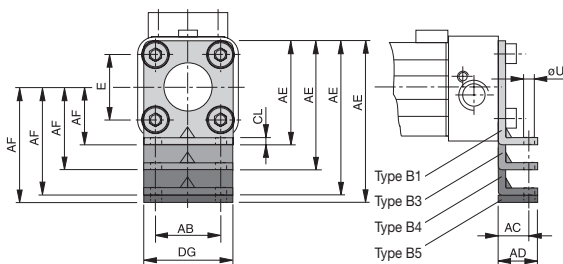
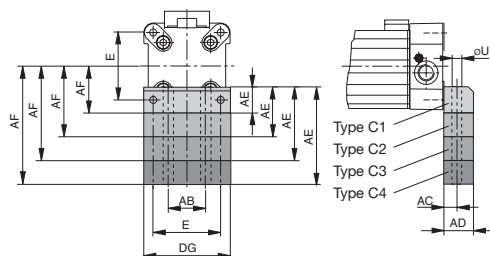
Series OSP-P16, 25, 32: Type A

Series OSP-P16, 25, 32: Type B

Series OSP-P40, 50, 63, 80: Type C

For inventory, lead times, and kit lookup, visit www.pdnplu.com

End Cap Mountings – Type B Ø 16 to 32mm

For Linear-drive with Recirculating Ball Bearing Guide

- Series OSP-P STL
- Series OSP-P KF

Material:

- Galvanized steel
- Anodized aluminum

The mountings are supplied in pairs.

Drawing shows: Mounting with Guide Type STL

**Type B1: 16, 25, 32mm
Series OSP-P STL and KF**

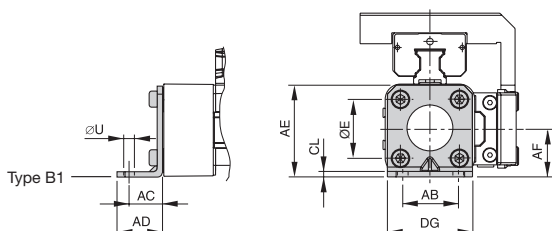
 Installation: Top carrier
Side piston

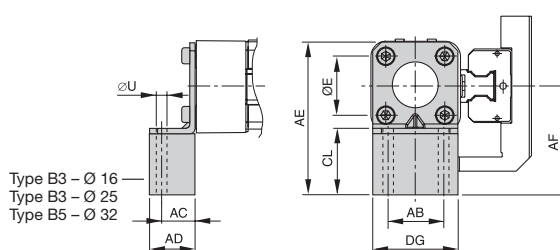
**Type B3: 16, 25mm
Type B5: 32mm
Series OSP-P STL and KF**

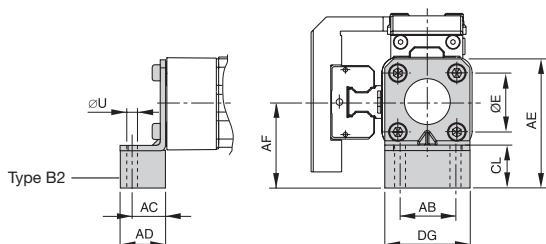
 Installation: Side carrier
Piston below

**Type B2: 16, 25, 32mm
Series OSP-P STL and KF**

 Installation: Side carrier
Top piston

Dimension (mm), Type B

Series Type	Mounting	E	ØU	AB	AC	AD	AE	AF	CL	DG	Part Number (pair)
OSP-P STL16	B1	18	3.6	18	10	14	28	15	2	26	21135FIL
OSP-P KF16	B2	18	3.6	18	10	14	43	30	17	26	21136FIL
	B3	18	3.6	18	10	14	55	42	29	26	21137FIL
OSP-P STL25	B1	27	5.8	27	16	22	42	22	2.5	39	20311FIL
OSP-P KF25	B2	27	5.8	27	16	22	57	37	17.5	39	21138FIL
	B3	27	5.8	27	16	22	69	49	29.5	39	21139FIL
OSP-P STL32	B1	36	6.6	36	18	26	55	30	3	50	20313FIL
OSP-P KF32	B2	36	6.6	36	18	26	69	44	17	50	21140FIL
	B5	36	6.6	36	18	26	90	65	9	50	21141FIL

 For inventory, lead times, and kit lookup, visit www.pdnplu.com

Rodless Pneumatic Cylinders

Mid-Section Support – Type D1ST Ø 16 to 50mm

For Linear-drive with Recirculating Ball Bearing Guide

- Series OSP-P STL
- Series OSP-P KF

Note: on Types D1ST

The mid-section support can also be mounted on the underside of the actuator, in which case its distance from the center of the actuator is different.

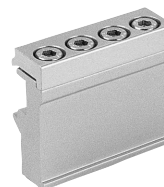

 Drawing shows: Mounting with Guide Type STL
 Mountings from below with 2 screws

P1X Series

**Type D1ST: 16 to 50mm
 Series OSP-P STL and KF**

GDL Series

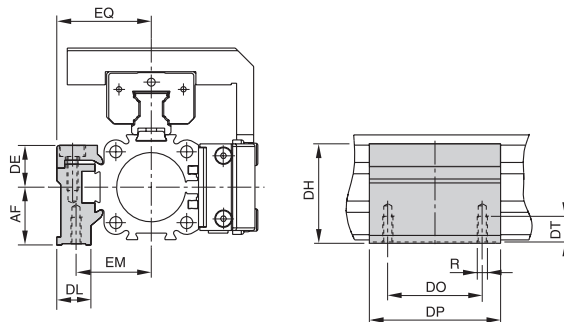
2002/P120 Series



P5S Electronic & Reed Sensors

Dimension (mm), Type D1ST

Series	Mounting	R	AF	DE	DH	DL	DO	DP	DT	EM	EQ	Part Number
OSP-P ...	D1ST	M3	15	14.2	29.2	14.6	18	30	6.5	20	27	21125FIL
	D1ST	M5	22	16	38	13	36	50	10	28.5	36	21126FIL
	D1ST	M5	30	16	46	13	36	60	10	35.5	43	21127FIL
	D1ST	M6	38	23	61	19	45	60	11	38	48	21128FIL
	D1ST	M6	48	23	71	19	45	60	11	45	57	21129FIL

Order example: Type D1ST16 Part number: 21125FIL

Part Number Index

Safety Guide, Offer of Sale

 For inventory, lead times, and kit lookup, visit www.pdnplu.com

Mid-Section Support

Information regarding type E1 and D1:

Mounting of the Mid-Section supports is also possible on the lower side of the drive. In this case, please note the new center line dimensions.

Stainless steel version on request.



Series OSP-P16 to 80: Type E
(Mounting from above / below using a cap screw)

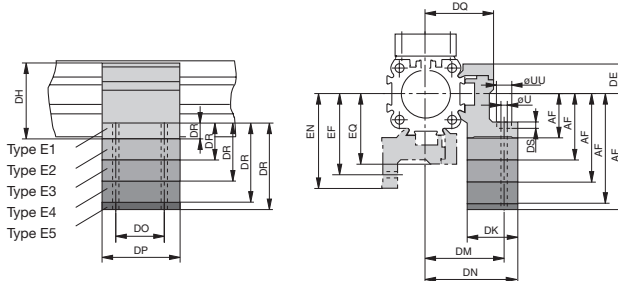

Series OSP-P16 to 80: Type D1
(Mounting from below with thread screw)

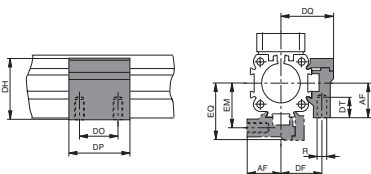

Dimension (mm) - AF and DR (Dependent on the mounting type)

Mount. type	DR for Size								AF for Size							
	16	25	32	40	50	63	80	16	25	32	40	50	63	80		
D1	-	-	-	-	-	-	-	15	22	30	38	48	57	72		
E1	6	8	10	10	10	12	15	15	22	30	38	48	57	72		
E2	21	23	24	23	19	-	-	30	37	44	51	57	-	-		
E3	33	35	32	32	34	48	53	42	49	52	60	72	93	110		
E4	-	46	40	42	57	-	-	60	60	70	95	-	-	-		
E5	-	-	45	-	-	-	-	-	65	-	-	-	-	-		

Dimension Table (mm)

Series	R	U	UU	DE	DF	DH	DK	DM	DN	DO	DP	DQ	DS	DT	EF	EM	EN	EQ
OSP-P16	M3	3.4	6	14.2	20	29.2	24	32	36.4	18	30	27	3.4	6.5	32	20	36.4	27
OSP-P25	M5	5.5	10	16	27	38	26	40	47.5	36	50	34.5	5.7	10	41.5	28.5	49	36
OSP-P32	M5	5.5	10	16	33	46	27	46	54.5	36	50	40.5	5.7	10	48.5	35.5	57	43
OSP-P40	M6	7	-	23	35	61	34	53	60	45	60	45	-	11	56	38	63	48
OSP-P50	M6	7	-	23	40	71	34	59	67	45	60	52	-	11	64	45	72	57
OSP-P63	M8	9	-	34	47.5	91	44	73	83	45	65	63	-	16	79	53.5	89	69
OSP-P80	M10	11	-	39.5	60	111.5	63	97	112	55	80	81	-	25	103	66	118	87

Ordering information for mountings – Type A, Type B, Type C, Type D, Type E

Mounting Type (versions)	Part Number							
	16	25	32	40	50	63	80	
A1 †	20408FIL	2010	3010	-	-	-	-	
A2 †	20464FIL	2040	3040FIL	-	-	-	-	
A3 †	-	2060FIL	3060FIL	-	-	-	-	
B1 †	-	20311FIL	20313FIL	-	-	-	-	
B3 †	20465FIL	-	-	-	-	-	-	
B4 †	-	20312FIL	20314FIL	-	-	-	-	
B5 †	-	-	20976FIL	-	-	-	-	
C1 †	-	-	-	4010FIL	5010FIL	6010FIL	8010FIL	
C2 †	-	-	-	20338FIL	20349FIL	-	-	
C3 †	-	-	-	20339FIL	20350FIL	20821FIL	20822FIL	
C4 †	-	-	-	20340FIL	20351FIL	-	-	
D1	20434FIL	20008FIL	20157FIL	20027FIL	20162FIL	20451FIL	20480FIL	
E1	20435FIL	20009FIL	20158FIL	20028FIL	20163FIL	20452FIL	20482FIL	
E2	20436FIL	20352FIL	20355FIL	20358FIL	20361FIL	-	-	
E3	20437FIL	20353FIL	20356FIL	20359FIL	20362FIL	20453FIL	20819FIL	
E4	-	20354FIL	20357FIL	20360FIL	20363FIL	-	-	
E5	-	-	20977FIL	-	-	-	-	

† Pair



For inventory, lead times, and kit lookup, visit www.pdnplu.com

Mid-Section Support – Type E1ST to E5ST Ø 16 to 50mm

For Linear-drive with Recirculating Ball Bearing Guide

- Series OSP-P STL
- Series OSP-P KF

 Drawing shows: Mounting with Guide Type STL
Mountings from below with 2 screws

Type E1ST: 16 to 50mm
Series OSP-P STL and KF

 Installation: Top carrier
Side position

Type E2ST: 16 to 50mm
Series OSP-P STL and KF

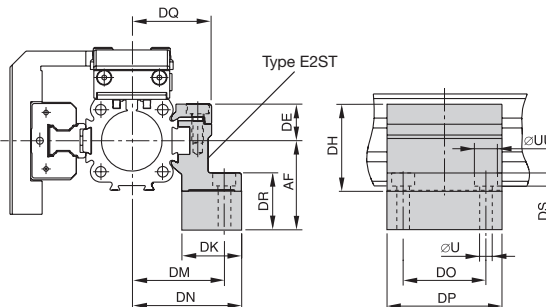
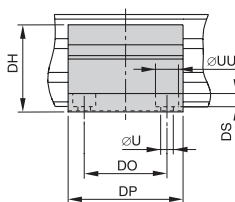
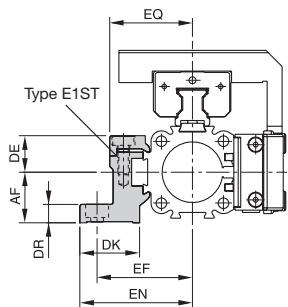
 Installation: Side carrier
Top piston

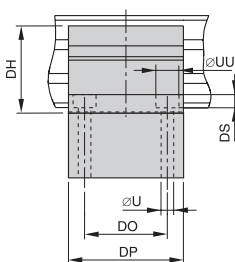
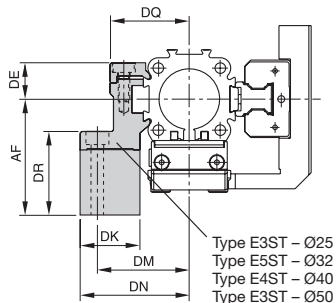
Type E3ST, E4ST, E5ST: 25 to 50mm
Series OSP-P STL and KF

 Installation: Side carrier
Piston below

Dimension (mm), Type E1ST to E5ST

Series	Mounting	ØU	ØUU	AF	DE	DH	DK	DM	DN	DO	DP	DR	DQ	DS	EF	EN	EQ	Part Number
OSP-P ...	E1ST	3.4	6	15	14.2	29.2	24	32	36.4	18	30	6	27	3.4	32	36.4	27	21130FIL
	E2ST	3.4	6	30	14.2	29.2	24	32	36.4	18	30	21	27	3.4	32	36.4	27	21142FIL
	E1ST	5.5	10	22	16	38	26	40	47.5	36	50	8	34.5	5.7	41.5	49	36	21131FIL
	E2ST	5.5	10	37	16	38	26	40	47.5	36	50	23	34.5	5.7	41.5	49	36	21143FIL
	E3ST	5.5	10	49	16	38	26	40	47.5	36	50	35	34.5	5.7	41.5	49	36	21148FIL
	E1ST	5.5	10	30	16	46	27	46	54.5	36	60	10	40.5	5.7	48.5	57	43	21132FIL
	E2ST	5.5	10	44	16	46	27	46	54.5	36	60	24	40.5	5.7	48.5	57	43	21144FIL
	E5ST	5.5	10	65	16	46	27	46	54.5	36	60	45	40.5	5.7	48.5	57	43	21151FIL
	E1ST	7	-	38	23	61	34	53	60	45	60	10	45	-	56	63	48	21133FIL
	E2ST	7	-	51	23	61	34	53	60	45	60	23	45	-	56	63	48	21145FIL
	E4ST	7	-	70	23	61	34	53	60	45	60	42	45	-	56	63	48	21150FIL
	E1ST	7	-	48	23	71	34	59	67	45	60	10	52	-	64	72	57	21134FIL
	E2ST	7	-	57	23	71	34	59	67	45	60	19	52	-	64	72	57	21146FIL
	E3ST	7	-	72	23	71	34	59	67	45	60	34	52	-	64	72	57	21149FIL

Order example: Type E1ST16 Part number: 21130FIL

 For inventory, lead times, and kit lookup, visit www.pdnplu.com

Mid-Section Support – Type MUP Ø 25 to 50mm (correspond to FESTO dimensions)

For Linear-drive with Recirculating Ball Bearing Guide

- Series OSP-P KF

Note: Correspond to FESTO DGPL-KF, when the Mid-Section Support MUP are mounted on the 90° side to the carriage (see drawings).

Series OSP-P KF25: Type MUP
 (Mounting over through holes)

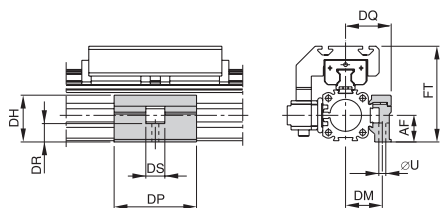

Series OSP-P KF32 to KF40: Type MUP
 (Mounting over through holes)

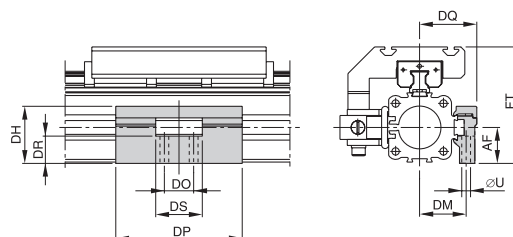

Series OSP-P KF50: Type MUP
 (Mounting over through holes)

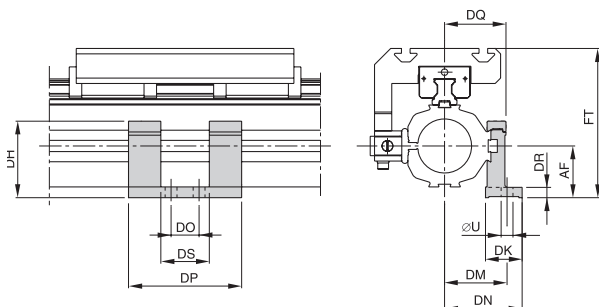

Dimension (mm)

Series	ØU	AF	DH	DK	DM	DN	DO	DP	DQ	DR	DS	FT	Part Number
MUP25	5.5	21	36.9	–	29	–	–	65	36	14.5	15	75.5	21119FIL
MUP32	6.6	27	42.9	–	35	–	22	95	43	20.5	35	87.5	21120FIL
MUP40	6.6	35	58	–	40	–	22	95	48	28.5	35	104.5	21121FIL
MUP50	11	48	71	34	58	72	26	105	57	10	45	138.5	21122FIL

Rodless Pneumatic Cylinders
OSP-P Series
P1X Series
GDL Series
2002/P120 Series
P5S Electronic & Reed Sensors
Accessories
Part Number Index
Safety Guide, Offer of Sale



For inventory, lead times, and kit lookup, visit www.pdnplu.com

Rodless Pneumatic Cylinders

End Cap Mountings – Type C Ø 40 to 50mm

For Linear-drive with Recirculating Ball Bearing Guide

- Series OSP-P STL
- Series OSP-P KF

Material:

- Anodized aluminum

The mountings are supplied in pairs.

Drawing shows: Mounting with Guide Type STL

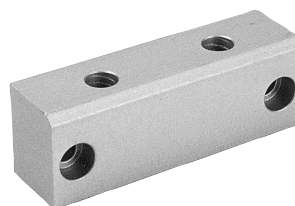

OSP-P Series

Type C1: 40, 50mm
 Series OSP-P STL and KF

 Installation: Top carrier
 Side piston

Type C4: 40mm
Type C3: 50mm
 Series OSP-P STL and KF

 Installation: Side carrier
 Piston below

P1X Series

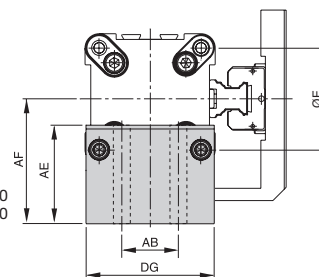
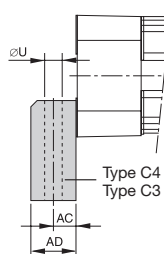
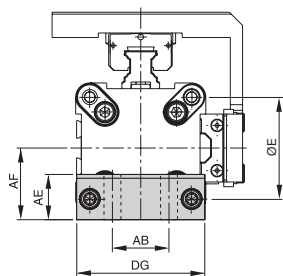
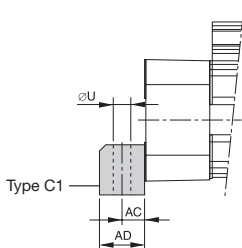

GDL Series

2002/P120 Series

Type C2: 40, 50mm
 Series OSP-P STL and KF

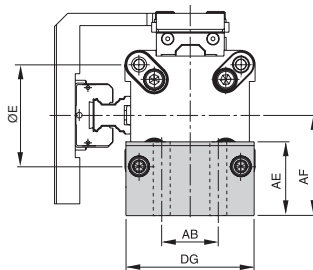
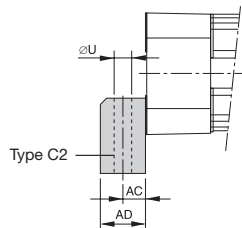
 Installation: Side carrier
 Top piston

P55 Electronic & Reed Sensors

Accessories

Part Number Index

Dimension (mm), Type C

Series Type	Mounting	E	$\varnothing U$	AB	AC	AD	AE	AF	DG	Part Number (pair)
OSP-P STL40	C1	54	9	30	12.5	24	24	38	68	4010FIL
OSP-P KF40	C2	54	9	30	12.5	24	37	51	68	20338FIL
	C4	54	9	30	12.5	24	56	70	68	20340FIL
OSP-P STL50	C1	70	9	40	12.5	24	30	48	86	5010FIL
OSP-P KF50	C2	70	9	40	12.5	24	39	57	86	20349FIL
	C3	70	9	40	12.5	24	54	72	86	20350FIL

Safety Guide, Offer of Sale

 For inventory, lead times, and kit lookup, visit www.pdnplu.com

Dovetail Cover, Ø16 to 80mm

- For clean guidance of magnetic switch cables along the cylinder body.
- Contains a maximum of 3 cables with diameter 3 mm.
- Material: Plastic
- Color: Red
- Temperature Range: -10 to 80°C

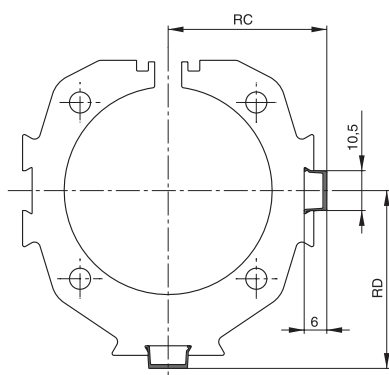
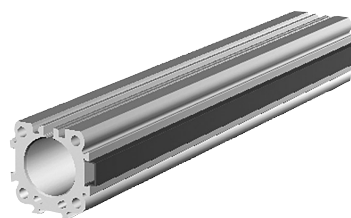

Dimension (mm) and Order Instructions

Series	Dimensions (mm)		Part Number
	RC	RD	
OSP-P16	18.5	19	13039FIL Minimal length: 1m Max. profile length: 2m Multiple profiles can be used.
OSP-P25	23.5	25.5	
OSP-P32	29.5	32	
OSP-P40	34.5	37.5	
OSP-P50	41.5	46.5	
OSP-P63	51.5	57.5	
OSP-P80	64.5	70.5	

Metric Conversion Fittings



Bore Size	Port Size	Part Number
P25	G1/8 to 1/8" NPT	2521-1/8-02
P32, P40, P50	G1/4 to 1/4" NPT	2521-1/4-04
P63	G3/8 to 3/8" NPT	2521-3/8-06
P80	G1/2 to 1/2" NPT	2521-1/2-08

Rodless Pneumatic Cylinders
OSP-P Series
P1X Series
GDL Series
2002/P120 Series
P5S Electronic & Reed Sensors
Accessories
Part Number Index
Safety Guide, Offer of Sale



For inventory, lead times, and kit lookup, visit www.pdnplu.com

Rodless Pneumatic Cylinders
OSP-P Series
P1X Series
GDL Series
2002/P120 Series
P55 Electronic & Reed Sensors
Accessories
Part Number Index
Safety Guide, Offer of Sale

Service Packs

	Bore Sizes							
	10mm	16mm	25mm	32mm	40mm	50mm	63mm	80mm
BUNA service pack single piston	3085x(stroke)	11111x(stroke)	11112x(stroke)	11113x(stroke)	11114x(stroke)	11115x(stroke)	11116x(stroke)	11118x(stroke)
Fluorocarbon service pack, single piston	3086x(stroke)	11121x(stroke)	11122x(stroke)	11123x(stroke)	11124x(stroke)	11125x(stroke)	11126x(stroke)	11128x(stroke)
BUNA service pack single piston - slow speed grease	—	11131x(stroke)	11132x(stroke)	11133x(stroke)	11134x(stroke)	11135x(stroke)	11136x(stroke)	11138x(stroke)
Fluorocarbon service pack, single piston - slow speed grease	—	11141x(stroke)	11142x(stroke)	11143x(stroke)	11144x(stroke)	11145x(stroke)	11146x(stroke)	11148x(stroke)

Note: (stroke) = stroke of cylinder in mm

Service Pack Information

Service Packs contain all the components necessary to completely rebuild a Parker rodless cylinder, are available. Each pack contains a complete seal kit, inner and outer bands, Parker grease tube, cleaning tool and repair instructions. It's all packaged in an easy-to-ship, easy-to-store box clearly labeled to indicate the cylinder type, bore and stroke for which it is intended. Contact your local Parker distributor for more information.

Seal & Service Kits

	Bore sizes						
	16mm	25mm	32mm	40mm	50mm	63mm	80mm
BUNA seal kit - standard cylinder	11052	11053	11054	11055	11056	11057	11058
Fluorocarbon seal kit - standard cylinder	11059	11060	11061	11062	11063	11064	11065
Service kit active brake - sideline carriage	—	11095	11096	11097FIL	11098FIL	—	—
Service kit active brake - standard cylinder	—	11822FIL	11823FIL	11824FIL	11825FIL	11826FIL	11827FIL
Service kit - multibrake	—	11089FIL	11090FIL	11091FIL	11092FIL	11093FIL	—

Seal Kit Information

Seal Kits include all seals, a tube of grease, bearing shoe, scraper and cleaning tool.



For inventory, lead times, and kit lookup, visit www.pdnplu.com

Displacement Measuring System for Automated Movement

Series SFI-plus (incremental measuring system) for cylinder series

- OSP-P..

Characteristics

- Contactless magnetic displacement measurement system
- Displacement length up to 5.5 m
- Resolution 0.1 mm (option: 1 mm)
- Displacement speed up to 10 m/s
- For linear and non-linear rotary motion
- Suitable for almost any control or display unit with a counter input

The SFI-plus magnetic displacement measuring system consists of 2 main components.

- **Measuring Scale**, self-adhesive magnetic measuring scale

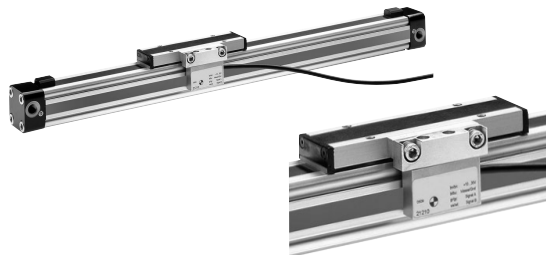

- **Sensing Head**, converts the magnetic poles into electrical signals which are then processed by counter inputs downstream (e.g. PLC, PC, digital counter)

Note: For combinations Active Brake AB + SFI-plus + Magnetic Switch contact our technical department please.

Characteristics

	Type 21210FIL	Type 21211FIL
Output Function		
Resolution	0.1mm	1mm
Pole lengths magnetic scale	5mm	5mm
Maximum speed	10 m/s	10 m/s
Repeat accuracy	± 1 Increment	± 1 Increment
Distance between sensor and scale	≤ 4mm	≤ 4mm
Tangential deviation	≤ 5°	≤ 5°
Lateral deviation	≤ ± 1.5 mm	≤ ± 1.5 mm
Switching output	PNP	PNP
Electrical Characteristics		
Operating voltage Ub	18 – 30 V DC	18 – 30 V DC
Voltage drop	≤ 2 V	≤ 2 V
Continuous current for each output	≤ 20 mA	≤ 20 mA
Power consumption at Ub = 24V, switched on, without load	≤ 50 mA	≤ 50 mA
Short-circuit protection	yes	yes
Reverse polarity protection	–	yes
Protection from inductive load	yes	yes
Power-up pulse suppression	yes	yes

	Type 21210FIL / 21211FIL
EMC	
Electrostatic discharge immunity	6, B, to EN 61000-4-2 kV
Electromagnetic field immunity	10, A, to EN61000-4-3 V/m
Electrical fast transient/burst immunity (for signal connections)	1, B, to EN 61000-4-4 kV
Electrical fast transient/burst immunity (for DC connections)	2, B, to EN 61000-4-4 kV
Surge immunity (for signal connections)	1, B, to EN 61000-4-5 kV
Surge immunity (for DC connections)	0,5, B, to EN 61000-4-5 kV
Immunity to conducted disturbances	10, A, to EN 61000-4-6 V
Power frequency magnetic field immunity at 50 Hz	30, A, to EN 61000-4-8 A/m
Emission standard for residential	to EN 61000-6-4
Radio disturbance characteristics	to EN 55011, Group 1, A
Mechanical Characteristics	
Housing	Aluminum
Cable length	5.0 m – fixed, open end
Cable cross section	4 x 0.14 mm ²
Cable type	PUR, black
Bending radius	≥ 36 mm
Weigh (mass)	ca. 0.165 kg
Environmental Conditions / Shock Resistance	
Degree of protection	IP67 to EN60529
Ambient temperature range	-25°C to 80°C
Broad-band random vibration to EN 60068-2-64	5 g, 5 Hz to 2 kHz, 0.5 h each axis
Vibration stress to EN 60068-2-6	12 g, 10 Hz to 2 kHz, 2 mm, 5 h each axis
Shock to EN 60068-2-27	100 g, 6 ms, 50 bumps each axis
Bump to EN 60068-2-29	5 g, 2 ms, 8000 bumps each axis

Rodless Pneumatic Cylinders
OSP-P Series
P1X Series
GDL Series
2002/P120 Series
P55 Electronic & Reed Sensors
Accessories
Part Number Index
Safety Guide, Offer of Sale



For inventory, lead times, and kit lookup, visit www.pdnplu.com

Rodless Pneumatic Cylinders
OSP-P Series
P1X Series
GDL Series
2002/P120 Series
P55 Electronic & Reed Sensors
Accessories
Part Number Index
Safety Guide, Offer of Sale

Sensing Head

The sensing head provides two pulsating, 90° out of phase counter signals (phase A/B) with a 0.4 mm resolution (option 4 mm).

External processing can improve the resolution to 0.1 mm (option 1 mm).

The counting direction can be determined automatically from the phase variance of the counter signals.

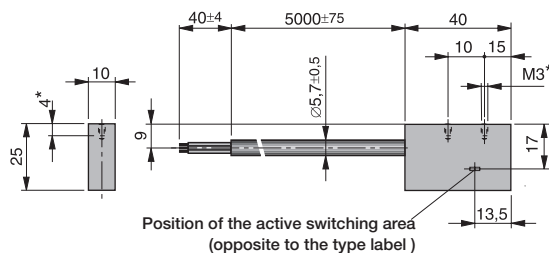

* Maximum thread depth 4mm

Electrical Connection

Color7	Description
RD = Red	10-30 VDC
BL = Black	Ground
YE = Yellow	Phase A
GN = Green	Phase B

Output signal – Sensing Head

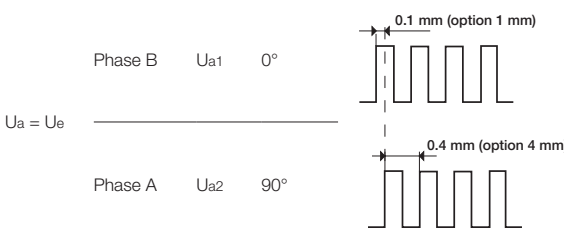

SFI-plus mounted on a rodless cylinder series OSP-P

The SFI-plus system can be mounted directly on a rodless OSP-P cylinder with the special mounting kit.

The position of the sensing head is generally 90° to the carrier.

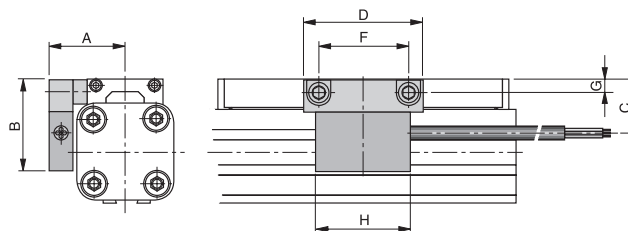

Combinations consisting of SFI-plus and OSP-P Cylinders with guides are available on request.

Dimension (mm)

Series	A	B	C	D	F	G	H
OSP-P25	32	39	23	50	38	5.5	40
OSP-P32	37.5	46	30	50	38	6.5	40
OSP-P40	42.5	50	34	50	38	6.5	40
OSP-P50	49.5	55	39	50	38	6.5	40
OSP-P63	59.5	65	49	50	38	10	40
OSP-P80	72.5	80	64	50	38	12	40



For inventory, lead times, and kit lookup, visit www.pdnplu.com

Order instructions

Description	Part Number
Sensing head with measuring scale – Resolution 0.1 mm (scale length = required measuring distance + a minimum of – see table below)	21240x(stroke)
Option: Sensing head with measuring scale – Resolution 1 mm (scale length = required measuring distance + a minimum of – see table below)	21241x(stroke)
Sensing head – Resolution 0.1 mm (spare part)	21210FIL
Option: Sensing head – Resolution 1 mm (spare part)	21211FIL
Measuring scale per meter (spare part)	21235FIL
Mounting kit for OSP-P25	21213FIL
Mounting kit for OSP-P32	21214FIL
Mounting kit for OSP-P40	21215FIL
Mounting kit for OSP-P50	21216FIL
Mounting kit for OSP-P63	21217FIL
Mounting kit for OSP-P80	21218FIL

* Overall length of the measuring scale results from stroke length of the cylinder + dead length
 Dead length for linear drives series OSP-P see table.

Series	Dead Length (mm)
OSP-P 25	154
OSP-P 32	196
OSP-P 40	240
OSP-P 50	280
OSP-P 63	350
OSP-P 80	422

Example:

Cylinder OSP-P, Ø25 mm, stroke length 1000 mm

$$\begin{array}{rcl}
 \text{dead length} & + & \text{stroke length} & = & \text{overall length of the measuring scale} \\
 154 \text{ mm} & + & 1000 \text{ mm} & = & 1154 \text{ mm}
 \end{array}$$

Rodless Pneumatic Cylinders
OSP-P Series
P1X Series
GDL Series
2002/P120 Series
P55 Electronic & Reed Sensors
Accessories
Part Number Index
Safety Guide, Offer of Sale



For inventory, lead times, and kit lookup, visit www.pdnplu.com

Parker Pneumatic

Rodless Pneumatic Cylinders
OSP-P Series
P1X Series
GDL Series
2002/P120 Series
P55 Electronic & Reed Sensors
Accessories
Part Number Index
Safety Guide, Offer of Sale



For inventory, lead times, and kit lookup, visit www.pdnplu.com



Rodless Pneumatic Cylinders
P1X Series

P1X Series - Band Type Rodless

Features	92
Ordering Information	93
Specifications / Technical Data	94-98
Dimensional Data	99-101
Accessories	102-109

Rodless Pneumatic Cylinders
OSP-P Series
P1X Series
GDL Series
2002/P120 Series
P5S Electronic & Reed Sensors
Accessories
Part Number Index
Safety Guide, Offer of Sale

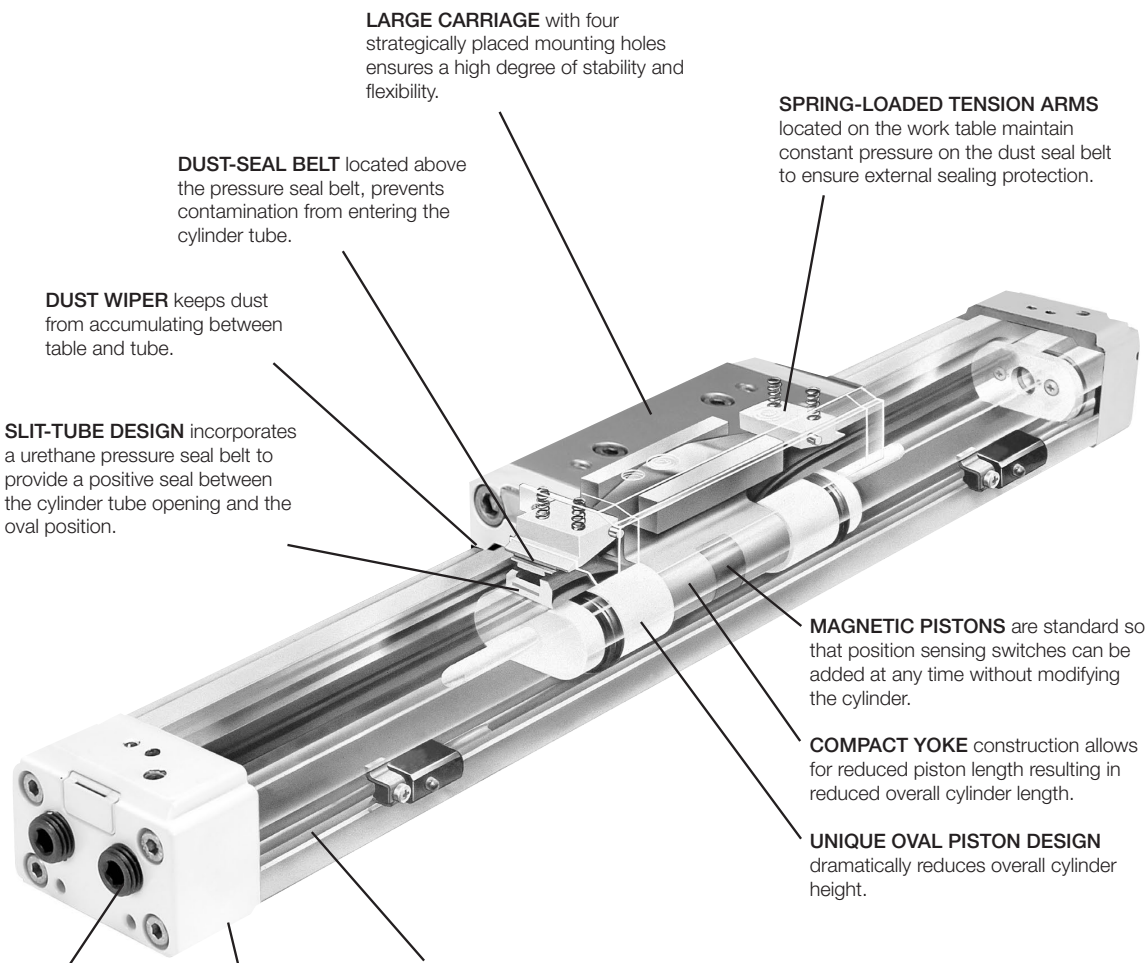

For inventory, lead times, and kit lookup, visit www.pdnplu.com

P1X Series

LARGE CARRIAGE with four strategically placed mounting holes ensures a high degree of stability and flexibility.

SPRING-LOADED TENSION ARMS located on the work table maintain constant pressure on the dust seal belt to ensure external sealing protection.

DUST-SEAL BELT located above the pressure seal belt, prevents contamination from entering the cylinder tube.

DUST WIPER keeps dust from accumulating between table and tube.

SLIT-TUBE DESIGN incorporates a urethane pressure seal belt to provide a positive seal between the cylinder tube opening and the oval position.

MAGNETIC PISTONS are standard so that position sensing switches can be added at any time without modifying the cylinder.

COMPACT YOKE construction allows for reduced piston length resulting in reduced overall cylinder length.

UNIQUE OVAL PISTON DESIGN dramatically reduces overall cylinder height.

ADDITIONAL PORTS IN ONE END CAP for optional piping location.

Note: End cap ports shown on this view are for representation only. Actual end ports are at other end of cylinder in relation to standard side ports and end ports are normally furnished plugged.

INTEGRAL SWITCH MOUNTING RAIL provides convenient mounting location for position sensing switches. Switches available include Solid State and Reed, AC or DC, with or without indicator lights. Bi-Color switches are available with 2 indicators to identify when maximum efficiency of contact is made.

ADJUSTABLE CUSHIONS for deceleration at end of stroke are standard.

Oval Piston Design

Oval piston design provides greater load carrying capacity than typical Rodless Pneumatic Cylinders with round pistons.

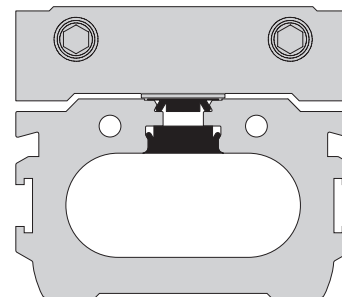

Rodless Pneumatic Cylinders
OSP-P Series
P1X Series
GDL Series
2002/P120 Series
P55 Electronic & Reed Sensors
Accessories
Part Number Index
Safety Guide, Offer of Sale



For inventory, lead times, and kit lookup, visit www.pdnplu.com

Rodless Pneumatic Cylinders P1X Series

Features

- 7 bore sizes – 16mm through 63mm
- Two port locations standard
- Large carriage for stability
- Integral sensor mounting rail
- Optional adjustable stroke and shock absorbers
- Stroke: maximum 5000mm, minimum 25mm



Operating information

Maximum pressure:	100 PSIG (7 bar)						
Minimum pressure:	<table border="0"> <tr> <td>Ø16, Ø20 bores</td> <td>29 PSI (2 bar)</td> </tr> <tr> <td>Ø25, Ø32, Ø40 bores</td> <td>14.5 PSI (1 bar)</td> </tr> <tr> <td>Ø50, Ø63 bores</td> <td>7 PSI (0.5 bar)</td> </tr> </table>	Ø16, Ø20 bores	29 PSI (2 bar)	Ø25, Ø32, Ø40 bores	14.5 PSI (1 bar)	Ø50, Ø63 bores	7 PSI (0.5 bar)
Ø16, Ø20 bores	29 PSI (2 bar)						
Ø25, Ø32, Ø40 bores	14.5 PSI (1 bar)						
Ø50, Ø63 bores	7 PSI (0.5 bar)						
Proof pressure:	152 PSI (10.5 bar)						
Temperature range:	40°F to 140°F (5°C to 60°C)						
Filtration requirements:	Filtered, nonlubricated compressed air						

Ordering Information

P1X	N	032	D	A	N	0500	W	D	N	N	N	-B																																																																																																									
<table border="1" style="width: 100%; border-collapse: collapse;"> <tr><td colspan="2">Series</td></tr> <tr><td>P1X</td><td>Global Rodless</td></tr> </table>	Series		P1X	Global Rodless	<table border="1" style="width: 100%; border-collapse: collapse;"> <tr><td colspan="2">Construction</td></tr> <tr><td>N</td><td>Inch</td></tr> <tr><td>M</td><td>Metric</td></tr> </table>	Construction		N	Inch	M	Metric	<table border="1" style="width: 100%; border-collapse: collapse;"> <tr><td colspan="2">Bore Size</td></tr> <tr><td>Ø16</td><td>16mm</td></tr> <tr><td>Ø20</td><td>20mm</td></tr> <tr><td>Ø25</td><td>25mm</td></tr> <tr><td>Ø32</td><td>32mm</td></tr> <tr><td>Ø40</td><td>40mm</td></tr> <tr><td>Ø50</td><td>50mm</td></tr> <tr><td>Ø63</td><td>63mm</td></tr> </table>	Bore Size		Ø16	16mm	Ø20	20mm	Ø25	25mm	Ø32	32mm	Ø40	40mm	Ø50	50mm	Ø63	63mm	<table border="1" style="width: 100%; border-collapse: collapse;"> <tr><td colspan="2">Carriage</td></tr> <tr><td>D</td><td>Double Acting</td></tr> </table>	Carriage		D	Double Acting	<table border="1" style="width: 100%; border-collapse: collapse;"> <tr><td colspan="2">Piston / Shock Style</td></tr> <tr><td>A</td><td>Cushions Both Ends (standard)</td></tr> <tr><td>R</td><td>Cushion Right End Only*</td></tr> <tr><td>L</td><td>Cushion Left End Only*</td></tr> <tr><td>N</td><td>No Cushions or Shock Absorbers</td></tr> <tr><td>H</td><td>Shock Absorber Both Ends</td></tr> <tr><td>B</td><td>Shock Absorber Right End Only</td></tr> <tr><td>C</td><td>Shock Absorber Left End Only</td></tr> </table>	Piston / Shock Style		A	Cushions Both Ends (standard)	R	Cushion Right End Only*	L	Cushion Left End Only*	N	No Cushions or Shock Absorbers	H	Shock Absorber Both Ends	B	Shock Absorber Right End Only	C	Shock Absorber Left End Only	<table border="1" style="width: 100%; border-collapse: collapse;"> <tr><td colspan="2">Seal Material</td></tr> <tr><td>N</td><td>Standard</td></tr> </table>	Seal Material		N	Standard	<table border="1" style="width: 100%; border-collapse: collapse;"> <tr><td colspan="2">Stroke Length*</td></tr> <tr><td colspan="2">0500</td></tr> </table>	Stroke Length*		0500		<table border="1" style="width: 100%; border-collapse: collapse;"> <tr><td colspan="2">Basic or Options</td></tr> <tr><td>B†</td><td>Standard</td></tr> <tr><td>W†</td><td>With Options</td></tr> <tr><td>/</td><td>Special (for factory use only)</td></tr> </table>	Basic or Options		B†	Standard	W†	With Options	/	Special (for factory use only)	<table border="1" style="width: 100%; border-collapse: collapse;"> <tr><td colspan="2">Porting Options</td></tr> <tr><td>N</td><td>NPTF (Std)</td></tr> <tr><td>G</td><td>BSPP</td></tr> <tr><td>Q</td><td>BSPT*</td></tr> </table> <p style="font-size: small;">* Not available with N construction</p>	Porting Options		N	NPTF (Std)	G	BSPP	Q	BSPT*	<table border="1" style="width: 100%; border-collapse: collapse;"> <tr><td colspan="2">Carriage Mounting Style</td></tr> <tr><td>D</td><td>Basic Mount</td></tr> <tr><td>A</td><td>Swivel Mount</td></tr> </table>	Carriage Mounting Style		D	Basic Mount	A	Swivel Mount	<table border="1" style="width: 100%; border-collapse: collapse;"> <tr><td colspan="4">Mounting Options</td></tr> <tr> <th>No Foot Mount</th> <th>End Mount Foot Bracket</th> <th>Bottom Mount Foot Bracket</th> <th>Intermediate Supports</th> </tr> <tr> <td>N (std)</td> <td>F</td> <td>A††</td> <td>No support</td> </tr> <tr> <td>H</td> <td>M</td> <td>B††</td> <td>One support</td> </tr> <tr> <td>K</td> <td>P</td> <td>C††</td> <td>Two supports</td> </tr> <tr> <td>T</td> <td>R</td> <td>D††</td> <td>Three supports</td> </tr> </table>	Mounting Options				No Foot Mount	End Mount Foot Bracket	Bottom Mount Foot Bracket	Intermediate Supports	N (std)	F	A††	No support	H	M	B††	One support	K	P	C††	Two supports	T	R	D††	Three supports	<table border="1" style="width: 100%; border-collapse: collapse;"> <tr><td colspan="2">Fastener Type</td></tr> <tr><td>N</td><td>Standard - Zinc-Plated</td></tr> <tr><td>S</td><td>Stainless Steel</td></tr> </table>	Fastener Type		N	Standard - Zinc-Plated	S	Stainless Steel
Series																																																																																																																					
P1X	Global Rodless																																																																																																																				
Construction																																																																																																																					
N	Inch																																																																																																																				
M	Metric																																																																																																																				
Bore Size																																																																																																																					
Ø16	16mm																																																																																																																				
Ø20	20mm																																																																																																																				
Ø25	25mm																																																																																																																				
Ø32	32mm																																																																																																																				
Ø40	40mm																																																																																																																				
Ø50	50mm																																																																																																																				
Ø63	63mm																																																																																																																				
Carriage																																																																																																																					
D	Double Acting																																																																																																																				
Piston / Shock Style																																																																																																																					
A	Cushions Both Ends (standard)																																																																																																																				
R	Cushion Right End Only*																																																																																																																				
L	Cushion Left End Only*																																																																																																																				
N	No Cushions or Shock Absorbers																																																																																																																				
H	Shock Absorber Both Ends																																																																																																																				
B	Shock Absorber Right End Only																																																																																																																				
C	Shock Absorber Left End Only																																																																																																																				
Seal Material																																																																																																																					
N	Standard																																																																																																																				
Stroke Length*																																																																																																																					
0500																																																																																																																					
Basic or Options																																																																																																																					
B†	Standard																																																																																																																				
W†	With Options																																																																																																																				
/	Special (for factory use only)																																																																																																																				
Porting Options																																																																																																																					
N	NPTF (Std)																																																																																																																				
G	BSPP																																																																																																																				
Q	BSPT*																																																																																																																				
Carriage Mounting Style																																																																																																																					
D	Basic Mount																																																																																																																				
A	Swivel Mount																																																																																																																				
Mounting Options																																																																																																																					
No Foot Mount	End Mount Foot Bracket	Bottom Mount Foot Bracket	Intermediate Supports																																																																																																																		
N (std)	F	A††	No support																																																																																																																		
H	M	B††	One support																																																																																																																		
K	P	C††	Two supports																																																																																																																		
T	R	D††	Three supports																																																																																																																		
Fastener Type																																																																																																																					
N	Standard - Zinc-Plated																																																																																																																				
S	Stainless Steel																																																																																																																				

* Stroke is ALWAYS in mm.
† When "B" is specified, the remaining digits in the part number are not necessary. If "W" is used, the remaining digits in the part number must be filled out.
†† Not available on 40, 50 and 63mm bore sizes.

	Essential Information
	Optional Features

Rodless Pneumatic Cylinders
OSP-P Series
P1X Series
GDL Series
2002/P120 Series
P55 Electronic & Reed Sensors
Accessories
Part Number Index
Safety Guide, Offer of Sale



For inventory, lead times, and kit lookup, visit www.pdnplu.com

Specifications, Weights and Forces

Specifications - P1X (standard with switch)

- Operating Medium: Compressed Air
- Bore Size mm (inch nominal): 16 (5/8) 20 (3/4), 25 (1) 32 (1-1/4), 40 (1-1/2) 50 (2), 63 (2-1/2)
- Port Size – N Series: M5 (10-32) 1/8 NPT 1/4 NPT 3/8 NPT
- Port Size – M Series: M5 (10-32) 1/8 Rc 1/4 Rc 3/8 Rc
- Stroke Tolerance in.: ±0.080 to 39" ±0.100 to 118" ±0.120 to 196"
- Piston Speed, *in./sec.: 2-80 IPS with side ports on each end
(Ø16 & Ø20 bores 2-40 IPS with single end porting with 39" stroke)
(Ø25, Ø32, Ø40, Ø50 & Ø63 bores 2-40 IPS with single end porting with 78" stroke)
- Cushion: Air Cushion Standard
- Lubrication: Not Required (if you choose to lubricate your system, continuing lubrication will be required.)

*Note: Actual piston speed with one end ports will vary depending on stroke length.

Weight & Theoretical Force Characteristics

Bore	Area In ²	Weights								Theoretical Force (lbs)				
		Weight at Zero Stroke						Weight per 1" (25.4mm) Stroke		at Pressure (PSI)				
		M00		MLB		MLB1		lbs	kg	30	40	60	80	100
16	0.31	0.70	0.3	0.73	0.3	0.77	0.4	0.07	0.03	9	12	19	25	31
20	0.49	1.15	0.5	1.19	0.5	1.28	0.6	0.10	0.04	15	20	29	39	49
25	0.84	2.21	1.0	2.43	1.1	2.43	1.1	0.15	0.07	23	30	46	61	76
32	1.26	3.31	1.5	3.53	1.6	3.75	1.7	0.20	0.09	38	50	69	100	125
40	1.96	5.29	2.4	5.51	2.5	—	—	0.27	0.12	59	78	117	156	195
50	3.08	7.94	3.6	8.16	3.7	—	—	0.40	0.18	91	122	182	243	304
63	4.86	13.67	6.2	14.33	6.5	—	—	0.63	0.28	145	193	290	386	483

Replacement Seal Kits
(includes inner & outer bands)

Bore (mm)	Part number
16	L079020016-(stroke)
20	L079020020-(stroke)
25	L080100025-(stroke)
32	L080100032-(stroke)
40	L080100040-(stroke)
50	L080100050-(stroke)
63	L080100063-(stroke)



For inventory, lead times, and kit lookup, visit www.pdnplu.com

Moments

Figure 1 shows the maximum allowable moments for each of the three types of loading: pitch, roll and yaw.

The sum total of each of these types of moments, divided by each of the maximum values, determines a Load-Moment Factor (LMF) should be equal to or less than 1.0. On horizontal mountings, the total load (L) should also be divided by the maximum load allowable (Figure 2) and factored into the equation.

Horizontal mountings:

$$\frac{L}{[L]} + \frac{M}{[M]} + \frac{Ms}{[Ms]} + \frac{Mv}{[Mv]} = LMF \leq 1.0$$

Vertical mountings:

$$\frac{M}{[M]} + \frac{Ms}{[Ms]} + \frac{Mv}{[Mv]} = LMF \leq 1.0$$

Figure 1

Maximum allowable moments n-m (lb-in)

Bore size	[M]		[Ms]		[Mv]	
	Pitch Moment		Roll Moment		Yaw Moment	
	Std.	Inverted	Std.	Inverted	Std.	Inverted
16	5 (44)	3.5 (31)	1 (9)	0.5 (4)	1 (9)	1 (9)
20	10 (89)	7 (62)	1.5 (13)	0.7 (6)	3 (27)	3 (27)
25	17 (150)	12 (106)	5 (44)	2.5 (22)	10 (89)	10 (89)
32	36 (319)	25 (221)	10 (89)	5 (44)	21 (186)	21 (186)
40	77 (682)	54 (478)	23 (204)	11.5 (102)	26 (230)	26 (230)
50	154 (1363)	108 (956)	32 (283)	16 (142)	42 (372)	42 (372)
63	275 (2434)	193 (1708)	52 (460)	26 (230)	76 (673)	76 (673)

Load and Deflection

Figure 2 shows the maximum load [L] that the cylinder can accept, as well as the maximum length [D] between supports at the maximum load.

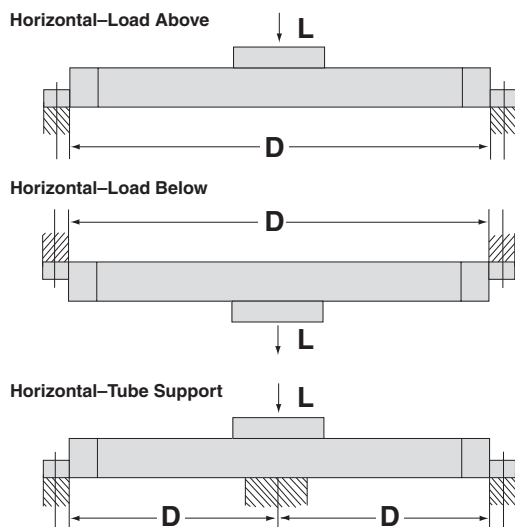

Rodless Pneumatic Cylinders P1X Series

Figure 2

Bore Size	Max. Allowable load [L] N (lbs)		Max. Unsupported Length mm (in) at Max. load
	Std.	Inverted	
16	141 (32)	70 (16)	450 (17.7)
20	198 (45)	101 (23)	551 (21.7)
25	356 (81)	180 (41)	899 (35.4)
32	616 (140)	308 (70)	749 (29.5)
40	959 (218)	480 (109)	1000 (39.4)
50	1456 (331)	726 (165)	1300 (51.2)
63	2297 (522)	1148 (261)	1600 (63.0)

Acceptable length and load combinations for various bore sizes can be determined from the charts in Figure 3.

Figure 3

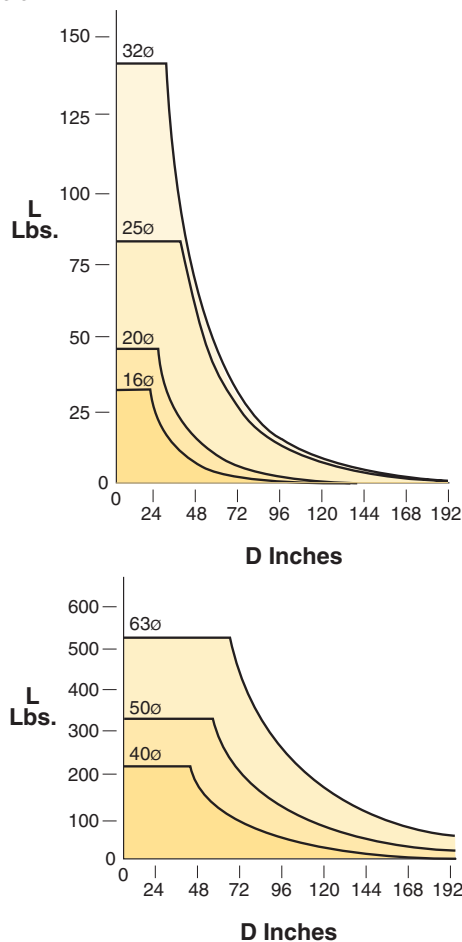

To determine cylinder deflections under the load (or resistive force perpendicular to the piston table) without mid-support, see the graphs on page 107.

Rodless Pneumatic Cylinders
OSP-P Series
P1X Series
GDL Series
2002/P120 Series
P55 Electronic & Reed Sensors
Accessories
Part Number Index
Safety Guide, Offer of Sale



For inventory, lead times, and kit lookup, visit www.pdnplu.com

Rodless Pneumatic Cylinders
OSP-P Series
P1X Series
GDL Series
2002/P120 Series
P55 Electronic & Reed Sensors
Accessories
Part Number Index
Safety Guide, Offer of Sale

Inertia Moment Consideration

When the weight is stopped at the end of the stroke by the cylinder cushion, inertial force is created. This inertial force (Fi) can be determined by using the formula:

$$F_i = LG$$

L = Load attached to the cylinder carriage (lbs.)

G = Inertia factor (Figure 1)

Example:

A speed of 40 in/sec corresponds to an inertia factor G of 13.

The inertial force calculated would then be multiplied by the distance from the center of gravity of the load to the centerline of the cylinder, and added to the previously calculated M and Mv moments. This will give an M Total and Mv Total. Ensure that the M Total and the Mv Total do not exceed the [M] and [Mv] values shown in Figure 5 (previous page). If they exceed these values, consult the factory.

See pages 106-107 for additional information on shock absorbers.

Figure 1

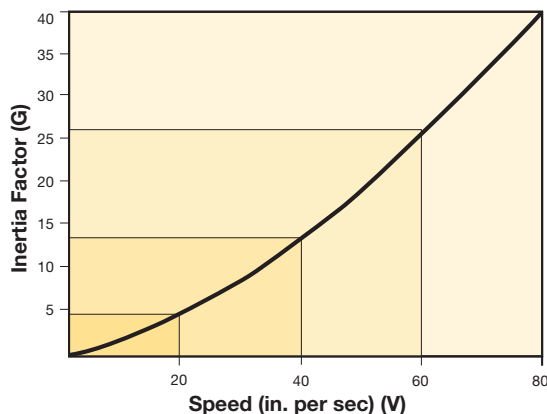

External Stops

When the load attached to the cylinder is stopped externally, it creates an additional moment equal to the cylinder force (Fa) times the distance (S). This additional moment, plus the previously calculated Load-Moment factor, should not exceed the allowable values. See previous page.

When reducing the stroke with external stops, remember that the cushion length and the energy absorption capacity are not directly proportional. Reducing the cushioning distance by 50% corresponds to a reduction of 60-70% in cushion effectiveness.

Figure 9

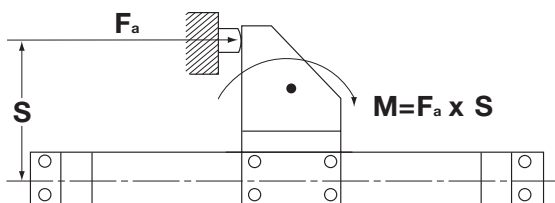

For inventory, lead times, and kit lookup, visit www.pdnplu.com

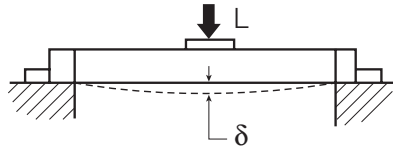

32 mm Bore

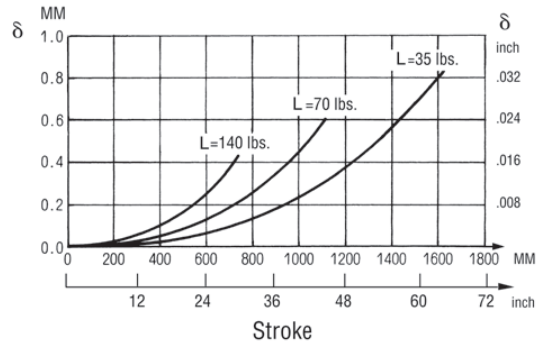

16 mm Bore

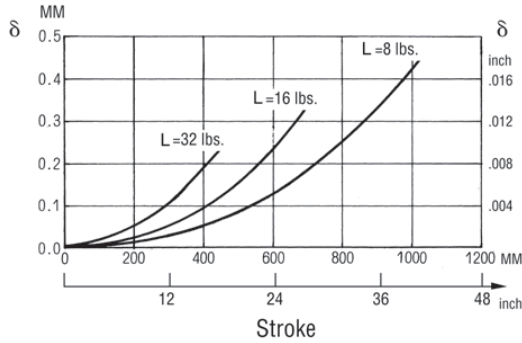

40 mm Bore

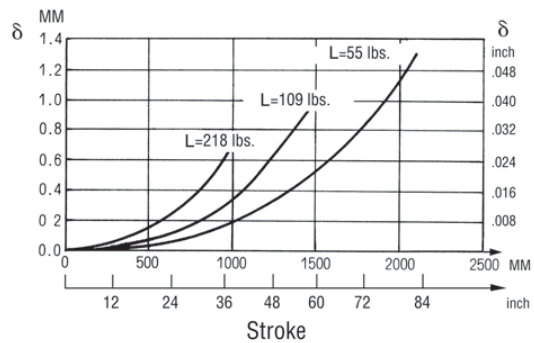

20 mm Bore

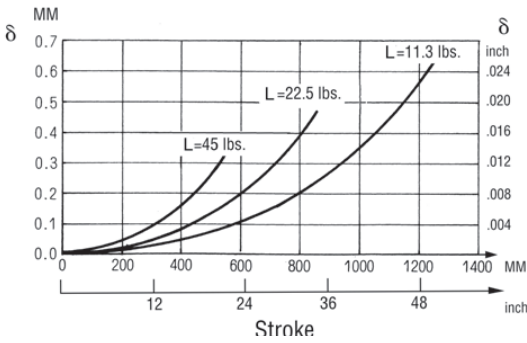

50 mm Bore

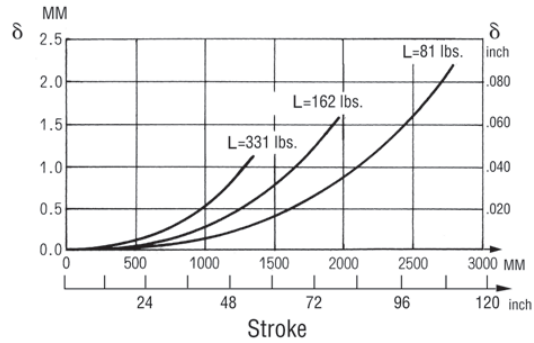

25 mm Bore

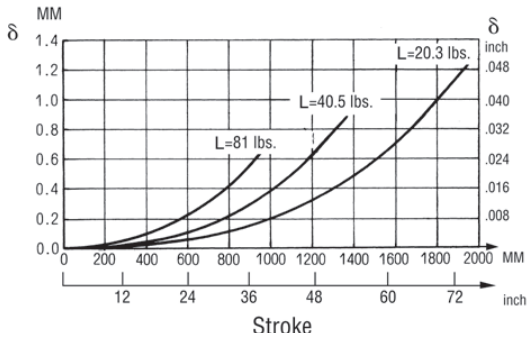

63 mm Bore

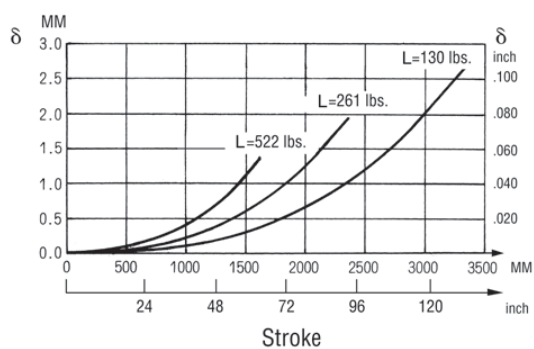

Rodless Pneumatic Cylinders
OSP-P Series
P1X Series
GDL Series
2002/P120 Series
P5S Electronic & Reed Sensors
Accessories
Part Number Index
Safety Guide, Offer of Sale



For inventory, lead times, and kit lookup, visit www.pdnplu.com

Piston Table Angular Deflection Due To Load Moments Applied

Rodless Pneumatic Cylinders
OSP-P Series
P1X Series
GDL Series
2002/P120 Series
P55 Electronic & Reed Sensors
Accessories
Part Number Index
Safety Guide, Offer of Sale

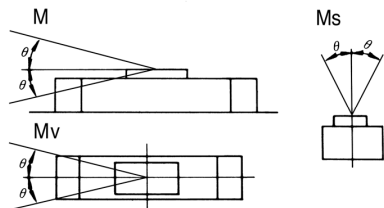

32 mm Bore

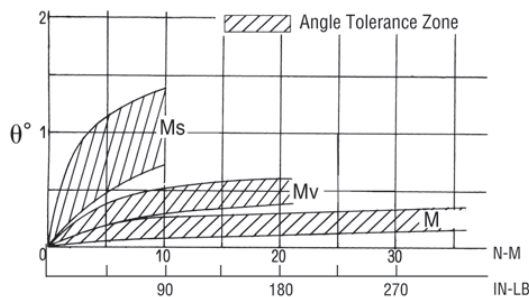

16 mm Bore

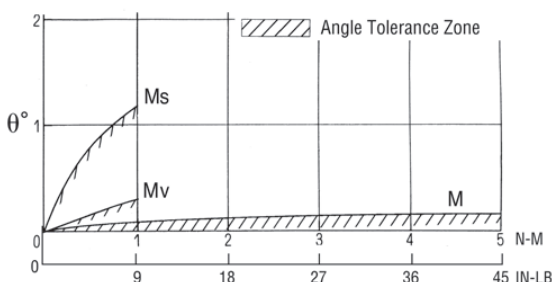

40 mm Bore

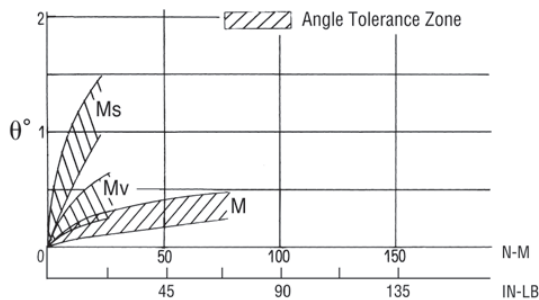

20 mm Bore

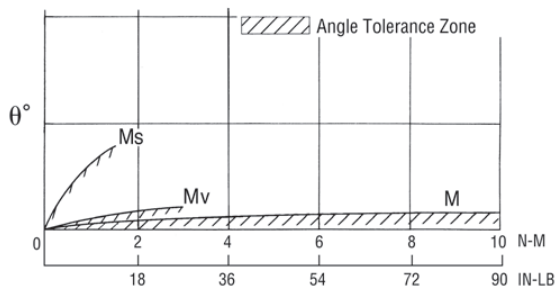

50 mm Bore

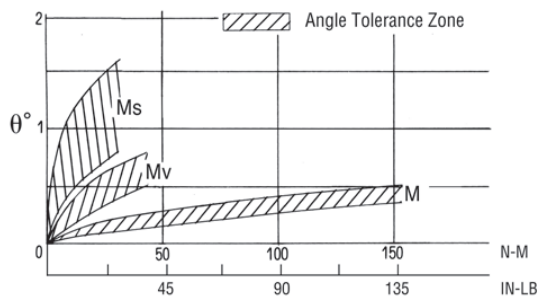

25 mm Bore

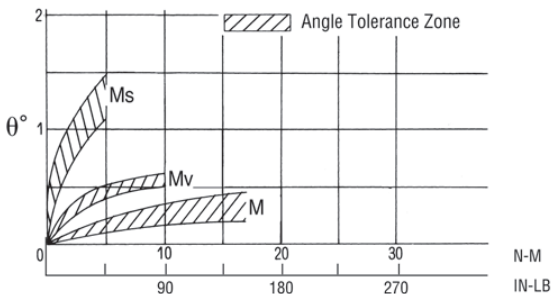

63 mm Bore

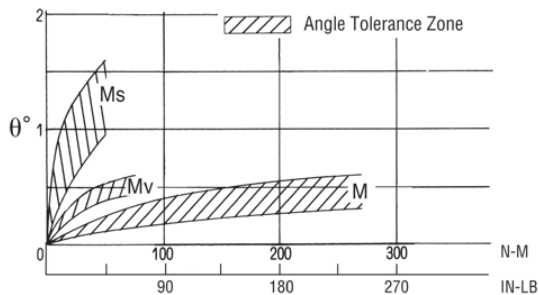

For inventory, lead times, and kit lookup, visit www.pdnplu.com

Basic Cylinder

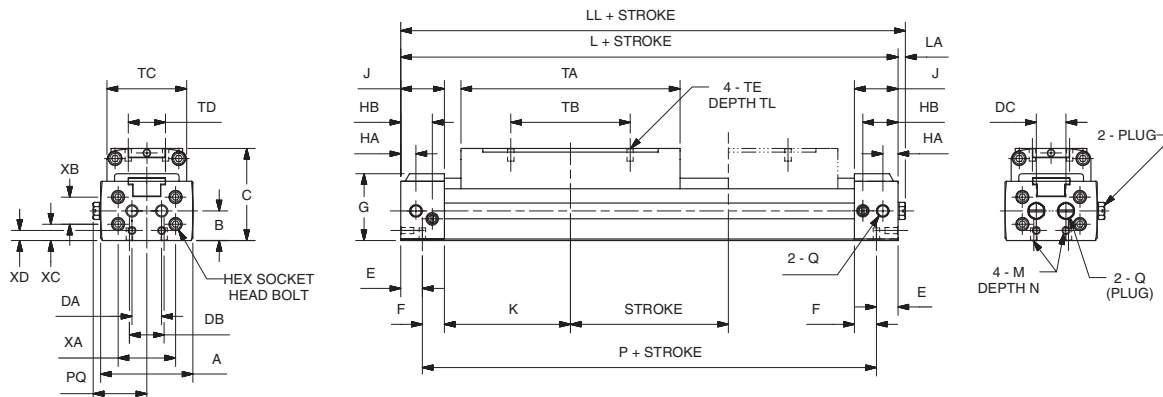

Bore (mm)	A	B	C	DA	DB	DC	E	F	G	HA	HB	J	K	L	LL	LA	M	N
16	1.46 (37)	0.47 (12)	1.46 (37)	0.47 (12)	0.55 (14)	0.47 (12)	0.34 (8.5)	0.35 (9)	1.06 (27)	0.24 (6)	0.55 (14)	0.69 (17.5)	2.24 (57)	5.87 (149)	5.98 (152)	0.12 (3)	5-40 (M3)	0.20 (5)
20	1.73 (44)	0.55 (14)	1.65 (42)	0.55 (14)	0.63 (16)	0.63 (16)	0.41 (10.5)	0.45 (11.5)	1.22 (31)	0.34 (8.5)	0.73 (18.5)	0.87 (22)	2.46 (62.5)	6.65 (169)	6.75 (171.5)	0.10 (2.5)	8-32 (M4)	0.26 (6.5)

Bore (mm)	P	PQ	Q	TA	TB	TC	TD	TE	TL	XA	XB	XC	XD
16	5.20 (132)	0.83 (21)	10-32 NPT (M5)	3.47 (88)	1.89 (48)	1.26 (32)	0.59 (15)	5-40 (M3)	0.20 (5)	0.91 (23)	0.43 (11)	0.26 (6.5)	0.16 (4)
20	5.83 (148)	0.97 (24.5)	1/8 NPT (1/8 Rc)	3.94 (100)	2.36 (60)	1.50 (38)	0.71 (18)	8-32 (M4)	0.24 (6)	1.10 (28)	0.63 (16)	0.24 (6)	0.20 (5)

inches (mm)

Rodless Pneumatic Cylinders
OSP-P Series
P1X Series
GDL Series
2002/P120 Series
P5S Electronic & Reed Sensors
Accessories
Part Number Index
Safety Guide, Offer of Sale



For inventory, lead times, and kit lookup, visit www.pdnplu.com

Basic Cylinder

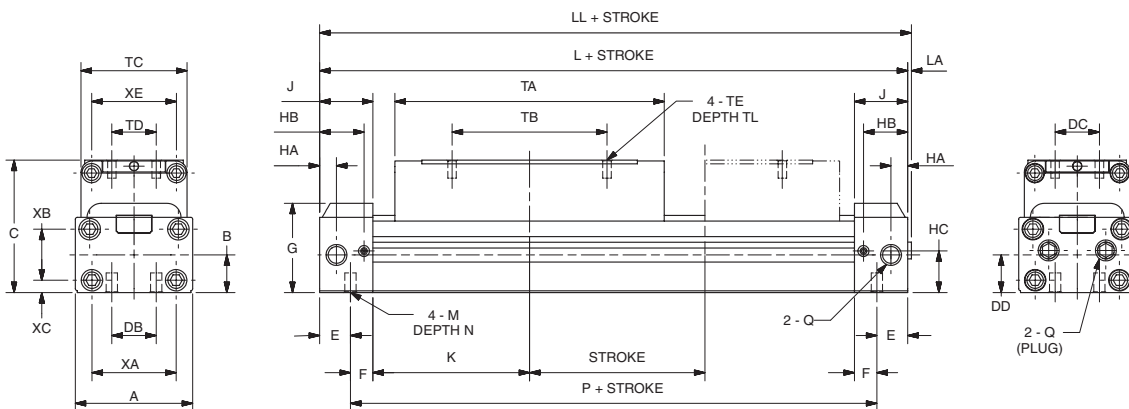

Bore (mm)	Series																		
	A	B	C	DB	DC	DD	E	F	G	HA	HB	HC	J	K	L	LL	LA	M	N
25	2.09	0.67	2.09	0.79	1.02	0.75	0.55	0.39	1.59	0.30	0.79	0.74	0.95	2.80	7.48	7.56	0.08	1/4-20	0.35
	(53)	(17)	(53)	(20)	(26)	(19)	(14)	(10)	(40.5)	(7.5)	(20)	(18.9)	(24)	(71)	(190)	(192)	(2)	(M6)	(9)
32	2.60	0.73	2.24	1.26	1.06	0.83	0.59	0.51	1.71	0.39	0.93	0.85	1.10	3.35	8.90	9.00	0.10	1/4-20	0.35
	(66)	(18.5)	(57)	(32)	(27)	(21)	(15)	(13)	(43.5)	(10)	(23.5)	(21.5)	(28)	(85)	(226)	(228.5)	(2.5)	(M6)	(9)
40	3.15	0.87	2.64	1.42	1.38	1.10	0.67	0.55	2.03	0.51	1.02	1.06	1.22	3.58	9.61	9.71	0.10	5/16-18	0.47
	(80)	(22)	(67)	(36)	(35)	(28)	(17)	(14)	(51.5)	(13)	(26)	(27)	(31)	(91)	(244)	(246.5)	(2.5)	(M8)	(12)
50	3.78	1.10	3.23	1.77	1.38	1.38	0.91	0.63	2.40	0.59	1.30	1.39	1.54	3.54	10.16	10.26	0.10	5/16-18	0.47
	(96)	(28)	(82)	(45)	(35)	(35)	(23)	(16)	(61)	(15)	(33)	(35.3)	(39)	(90)	(258)	(260.5)	(2.5)	(M8)	(12)
63	4.65	1.38	3.74	1.97	1.54	1.65	0.75	0.79	2.91	0.59	1.26	1.69	1.54	4.29	11.65	11.75	0.10	3/8-16	0.59
	(118)	(35)	(95)	(50)	(39)	(42)	(19)	(20)	(74)	(15)	(32)	(43)	(39)	(109)	(296)	(298.5)	(2.5)	(M10)	(15)

Bore (mm)	P55 Electronic & Reed Sensors												
	P	Q	TA	TB	TC	TD	TE	TL	XA	XB	XC	XE	
25	6.38	1/8 NPT	4.80	2.76	1.89	0.79	10-24	0.32	1.50	0.91	0.22	1.58	
	(162)	(1/8 Rc)	(122)	(70)	(48)	(20)	(M5)	(8)	(38)	(23)	(5.5)	(40)	
32	7.72	1/4 NPT	5.28	3.15	2.21	0.79	1/4-20	0.35	1.89	0.98	0.24	1.85	
	(196)	(1/4 Rc)	(134)	(80)	(56)	(20)	(M6)	(9)	(48)	(25)	(6)	(47)	
40	8.27	1/4 NPT	5.83	3.54	2.68	1.18	1/4-20	0.43	2.36	1.18	0.28	2.28	
	(210)	(1/4 Rc)	(148)	(90)	(68)	(30)	(M6)	(11)	(60)	(30)	(7)	(58)	
50	8.35	3/8 NPT	5.98	3.94	3.15	1.18	5/16-18	0.51	2.91	1.42	0.39	2.76	
	(212)	(3/8 Rc)	(152)	(100)	(80)	(30)	(M8)	(13)	(74)	(36)	(10)	(70)	
63	10.16	3/8 NPT	6.61	4.33	4.02	1.58	5/16-18	0.51	3.78	1.65	0.55	3.54	
	(258)	(3/8 Rc)	(168)	(110)	(102)	(40)	(M8)	(13)	(96)	(42)	(14)	(90)	

inches (mm)



For inventory, lead times, and kit lookup, visit www.pdnplu.com

End Mount Foot Bracket

16 to 32 mm bore sizes

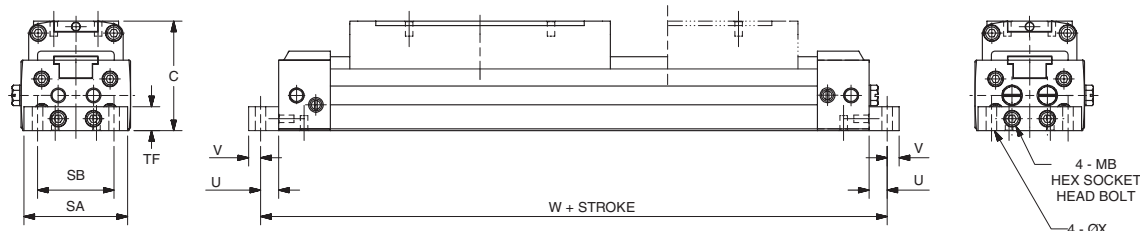

40 to 63 mm bore sizes

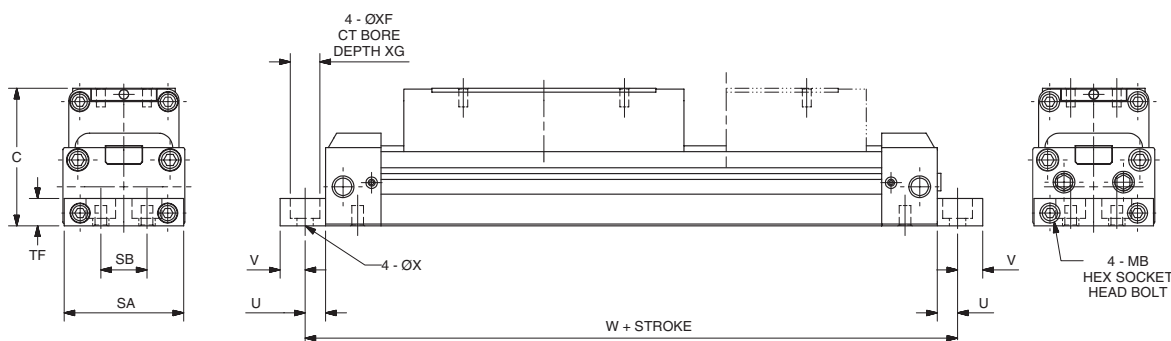

Bore (mm)	C	SA	SB	TF	U	V	W	X	XF	XG	MB
16	1.46 (37)	1.38 (35)	1.02 (26)	0.32 (8)	0.24 (6)	0.16 (4)	6.34 (161)	0.14 (3.6)	—	—	M3x10
20	1.65 (42)	1.69 (43)	1.30 (33)	0.39 (10)	0.24 (6)	0.24 (6)	7.13 (181)	0.19 (4.7)	—	—	M4x12
25	2.09 (53)	2.05 (52)	0.79 (20)	0.47 (12)	0.35 (9)	0.43 (11)	8.19 (208)	0.28 (7)	—	—	M5x50
32	2.24 (57)	2.52 (64)	1.26 (32)	0.47 (12)	0.35 (9)	0.43 (11)	9.61 (244)	0.28 (7)	—	—	M5x50
40	2.64 (67)	3.15 (80)	1.42 (36)	0.59 (15)	0.49 (12.5)	0.45 (11.5)	10.60 (269)	0.35 (9)	0.51 (13)	0.34 (8.7)	M6x55
50	3.23 (82)	3.70 (94)	1.77 (45)	0.79 (20)	0.49 (12.5)	0.45 (11.5)	11.10 (283)	0.35 (9)	0.51 (13)	0.34 (8.7)	M8x65
63	3.74 (95)	4.57 (116)	1.97 (50)	0.98 (25)	0.59 (15)	0.59 (15)	12.80 (326)	0.43 (11)	0.61 (15.5)	0.41 (10.5)	M8x70

inches (mm)

Rodless Pneumatic Cylinders
OSP-P Series
P1X Series
GDL Series
2002/P120 Series
P55 Electronic & Reed Sensors
Accessories
Part Number Index
Safety Guide, Offer of Sale



For inventory, lead times, and kit lookup, visit www.pdnplu.com

Accessories - Bracket

Bottom Mount Foot Bracket

16 to 20 mm bore sizes

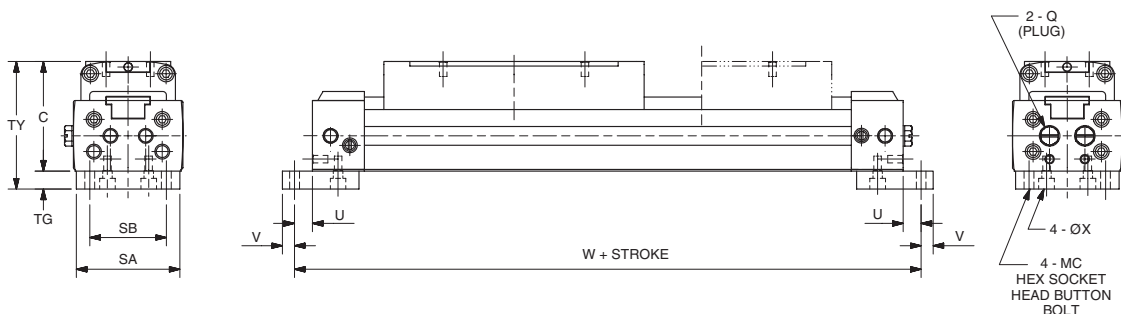

25 to 32 mm bore sizes

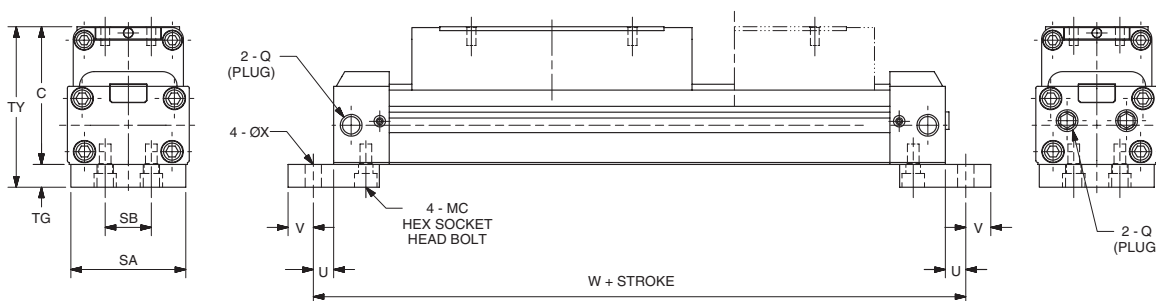

Bore (mm)	C	Q	SA	SB	TG	TY	U	V	W	X	MC
16	1.46 (37)	10-32 (M5)	1.38 (35)	1.02 (26)	0.24 (6)	1.69 (43)	0.24 (6)	0.16 (4)	6.34 (161)	0.13 (3.4)	5-40, 1/4 LG
20	1.65 (42)	1/8 NPT (1/8 Rc)	1.69 (43)	1.30 (33)	0.32 (8)	1.97 (50)	0.24 (6)	0.24 (6)	7.13 (181)	0.18 (4.5)	8-32, 3/8 LG
25	2.09 (53)	1/8 NPT (1/8 Rc)	1.97 (50)	0.79 (20)	0.39 (10)	2.48 (63)	0.35 (9)	0.43 (11)	8.19 (208)	0.28 (7)	1/4-20 x 1/2 LG
32	2.24 (57)	1/4 NPT (1/4 Rc)	2.52 (64)	1.26 (32)	0.39 (10)	2.64 (67)	0.35 (9)	0.43 (11)	9.61 (244)	0.28 (7)	1/4-20 x 1/2 LG
40	2.64 (67)	1/4 NPT (1/4 Rc)	—	—	—	—	—	—	—	—	—
50	3.23 (82)	3/8 NPT (3/8 Rc)	—	—	—	—	—	—	—	—	—
63	3.74 (95)	3/8 NPT (3/8 Rc)	—	—	—	—	—	—	—	—	—

inches (mm)



For inventory, lead times, and kit lookup, visit www.pdnplu.com

Intermediate support brackets (2 per kit)

End mount

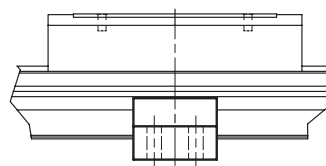
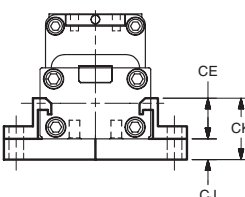
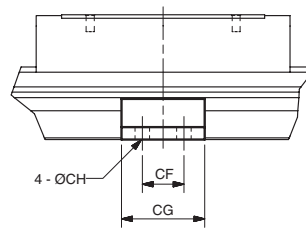
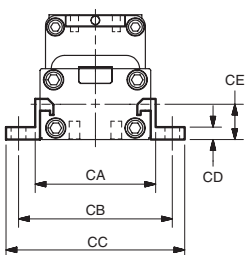
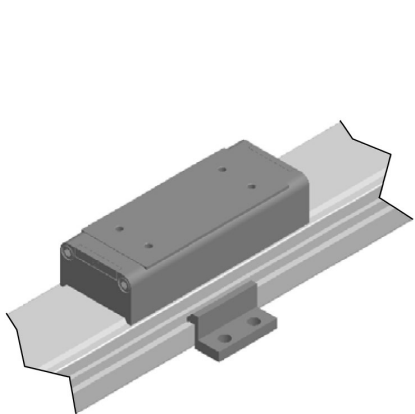

Bore (mm)	CA	CB	CC	CD	CE	CF	CG	CH
16	1.654 (42)	2.205 (56)	2.52 (64)	0.118 (3)	0.472 (12)	0.787 (20)	1.378 (35)	0.157 (4)
20	1.929 (49)	2.52 (64)	2.953 (75)	0.157 (4)	0.551 (14)	0.787 (20)	1.496 (38)	0.197 (5)
25	2.362 (60)	2.992 (76)	3.465 (88)	0.236 (6)	0.768 (19.5)	0.787 (20)	1.575 (40)	0.276 (7)
32	2.913 (74)	3.465 (88)	3.937 (100)	0.236 (6)	0.846 (21.5)	0.787 (20)	1.575 (40)	0.276 (7)
40	3.543 (90)	4.252 (108)	4.882 (124)	0.236 (6)	0.965 (24.5)	1.181 (30)	2.362 (60)	0.354 (9)
50	4.173 (106)	4.882 (124)	5.512 (140)	0.315 (8)	1.201 (30.5)	1.181 (30)	2.362 (60)	0.354 (9)
63	5.118 (130)	5.984 (152)	6.772 (172)	0.394 (10)	1.516 (38.5)	1.969 (50)	3.543 (90)	0.433 (11)

Bore (mm)	CJ	CK	Kit Part Number	
			End Mount or No Mount	Bottom Mount
16	0.236 (6)	0.709 (18)	L080180016	L080190016
20	0.315 (8)	0.866 (22)	L080180020	L080190020
25	0.394 (10)	1.161 (29.5)	L080180025	L080190025
32	0.394 (10)	1.24 (31.5)	L080180032	L080190032
40	—	—	L080180040	
50	—	—	L080180050	
63	—	—	L080180063	

inches (mm)

Rodless Pneumatic Cylinders
OSP-P Series
P1X Series
GDL Series
2002/P120 Series
P55 Electronic & Reed Sensors
Accessories
Part Number Index
Safety Guide, Offer of Sale



For inventory, lead times, and kit lookup, visit www.pdnplu.com

Swivel mount

Absorbs misalignment between cylinder and load

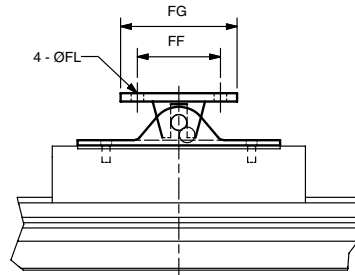
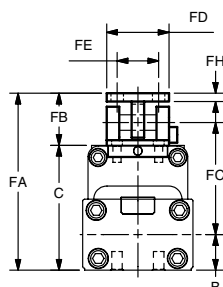
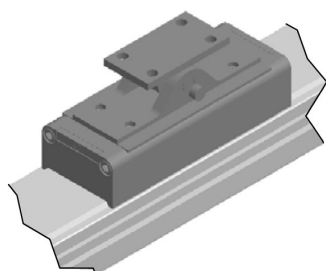

FJ dimension is the maximum horizontal float

FK dimension is the maximum vertical float

Bore (mm)	FA	FB	FC	FD	FE	FF	FG	FH
16	2.238 (58)	0.827 (21)	1.339 (34)	0.945 (24)	0.673 (16)	1.181 (30)	1.575 (40)	0.118 (3)
20	2.638 (67)	0.984 (25)	1.535 (39)	1.181 (30)	0.787 (20)	1.575 (40)	2.205 (56)	0.157 (4)
25	3.071 (78)	0.984 (25)	1.85 (47)	1.181 (30)	0.787 (20)	1.575 (40)	2.205 (56)	0.157 (4)
32	3.74 (95)	1.496 (38)	2.185 (55.5)	1.772 (45)	1.181 (30)	1.969 (50)	2.756 (70)	0.236 (6)
40	4.134 (105)	1.496 (38)	2.441 (62)	1.772 (45)	1.181 (30)	1.969 (50)	2.756 (70)	0.236 (6)
50	4.961 (126)	1.732 (44)	2.874 (73)	2.362 (60)	1.575 (40)	2.756 (70)	3.543 (90)	0.315 (8)
63	5.472 (139)	1.732 (44)	3.11 (79)	2.362 (60)	1.575 (40)	2.756 (70)	3.543 (90)	0.315 (8)

Bore (mm)	FJ	FK	FL	B	C	Part Number
16	inches 0.118	0.118	0.134	0.472	1.457	L078930016
	mm 3	3	3.4	12	37	L078930016
20	inches 0.118	0.118	0.177	0.551	1.654	L080160020
	mm 3	3	4.5	14	42	L08016M020
25	inches 0.118	0.118	0.236	0.669	2.087	L080160025
	mm 3	3	6	17	53	L08016M025
32	inches 0.197	0.197	0.276	0.728	2.244	L080160032
	mm 5	5	7	18.5	57	L08016M032
40	inches 0.197	0.197	0.276	0.866	2.638	L080160040
	mm 5	5	7	22	67	L08016M040
50	inches 0.197	0.197	0.354	1.102	3.228	L080160050
	mm 5	5	9	28	82	L08016M050
63	inches 0.197	0.197	0.354	1.378	3.74	L080160063
	mm 5	5	9	35	95	L08016M063

inches (mm)



For inventory, lead times, and kit lookup, visit www.pdnplu.com

End Port Piping

Refer to chart below to determine when end port piping can be used with various types of mountings relative to fitting clearance.

On all bore sizes with foot mounting, the end port pipe fittings will obstruct the mounting holes. To avoid this problem, mount the cylinder first and tighten the mounting bolts and then attach the pipe fittings to the cylinder ports.

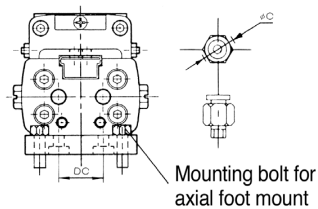

Bore (mm)	øC [O.D. of Fittings - mm (in.)]		
	No Mount	End Mount	Bottom Mount
16	12 (0.472)		12 (0.472)
20	16 (0.630)	End Port Piping	16 (0.630)
25	26 (1.024)	Not Available	26 (1.024)
32	27 (1.065)		27 (1.063)
40	35 (1.378)	26 (1.024)	
50	35 (1.378)	30 (1.181)	
63	39 (1.535)	34 (1.339)	

Rodless Pneumatic Cylinders
OSP-P Series
P1X Series
GDL Series
2002/P120 Series
P55 Electronic & Reed Sensors
Accessories
Part Number Index
Safety Guide, Offer of Sale



For inventory, lead times, and kit lookup, visit www.pdnplu.com

Rodless Pneumatic Cylinders
OSP-P Series
P1X Series
GDL Series
2002/P120 Series
P55 Electronic & Reed Sensors
Accessories
Part Number Index
Safety Guide, Offer of Sale

Shock Absorbers Selection Criteria

The Shock Absorber Advantage

- Increase equipment throughput
- Smoother deceleration of loads
- Adjustable end of stroke positioning
- Prevents impact damage
- Minimize shock loads on equipment
- Improves product performance

Four Steps to Great Performance

Step 1. Gather the Application Parameters

- Total load weight (pounds)
- Final velocity at impact (inches/second)*
- Cycle rate (cycles per hour)

Step 2. Verify Shock Absorber Performance

- See charts on the following pages
- Determine that shock absorber will do the job

*If final velocity cannot be easily calculated, double the average velocity.

Step 3. Verify the Cycle Rate

- See shock specifications below and verify application is within cycle rate

Step 4. Choose the Appropriate Option in Model Code

Shock absorber specifications

Cylinder	16mm	20mm	25mm	32mm	40mm	50, 63mm
Shock Absorber Number	109556	109559	109560	109561	109562	MC600MH
Max. energy absorption - in-lbs (kgf-m)	26.0 (0.3)	60.8 (0.7)	104.2 (1.2)	226 (2.6)	608 (7.0)	1042 (12)
Stroke - inches	0.236	0.315	0.394	0.590	0.787	0.984
Energy absorption / hour - in.-lbs / hour	54,700	109,380	187,510	338,560	729,200	750,000
Max. impact velocity - in. / sec.	59	59	78.7	78.7	98.4	118.1
Max. cycle rate per hour	2100	1800	1800	1500	1200	720
Ambient temperature - °F (°C)	41-140 (5-60)					
Spring return force - lb. Extended	0.65	0.45	0.65	1.33	2.20	3.60
Compressed	1.01	0.97	1.33	2.65	4.86	7.49
Return time - Sec.	0.3	0.3	0.3	0.3	0.4	0.4



For inventory, lead times, and kit lookup, visit www.pdnplu.com

Performance data (16 to 32mm bores)

16 mm Bore

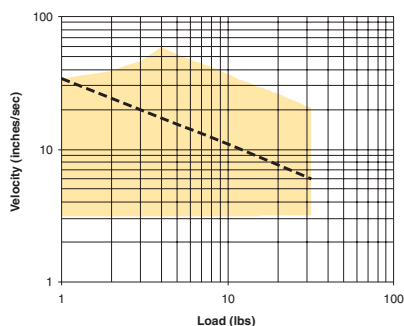

--- Air Cushion w/back pressure (flow controls or other meter out device)
Shock Absorber

- Notes:
1. If the cylinder is vertical in orientation, double the total load for bottom shock absorber.
 2. Use the total load that is being moved by shock absorber. If a weight transfer application, this would include La.
 3. If final velocity cannot be easily determined, use two times the stroke divided by the stroke time.

20 mm Bore

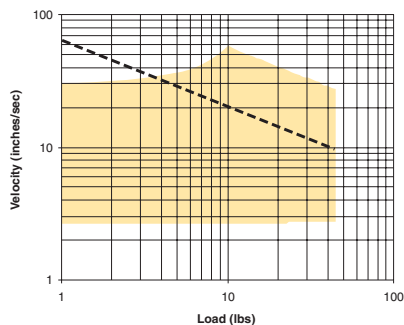

40 mm Bore

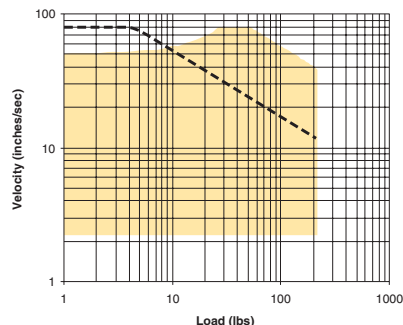

25 mm Bore

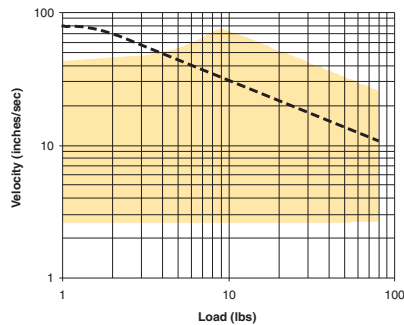

50 mm Bore

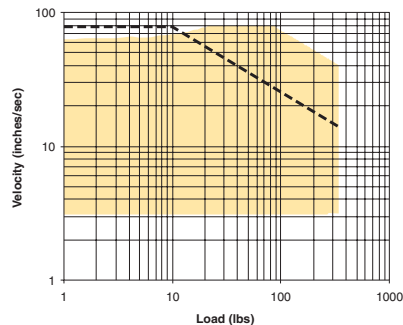

32 mm Bore

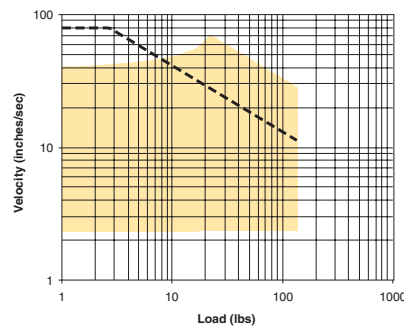

63 mm Bore

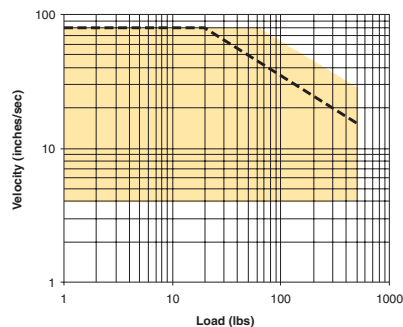

Rodless Pneumatic Cylinders

OSP-P Series

P1X Series

GDL Series

2002/P120 Series

P5S Electronic & Reed Sensors

Accessories

Part Number Index

Safety Guide, Offer of Sale



For inventory, lead times, and kit lookup, visit www.pdnplu.com

Stroke Adjustments and Shock Absorber Dimensions

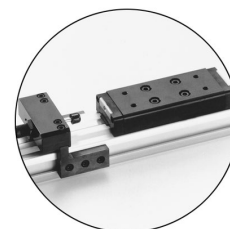

16 to 25mm bore sizes

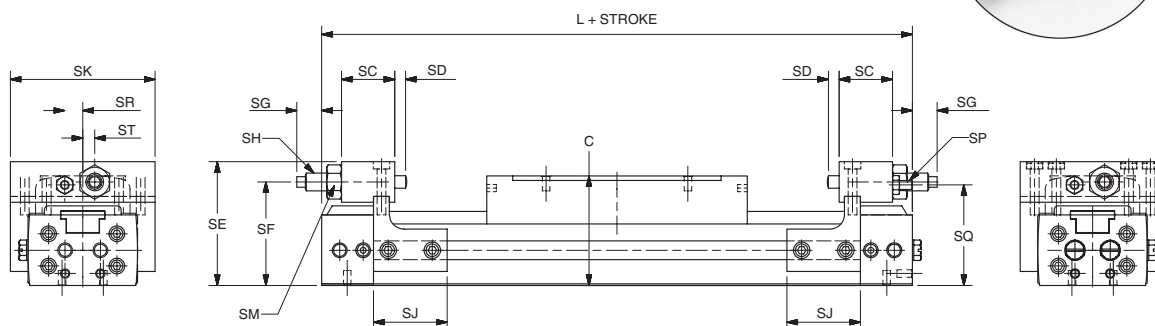

Bore (mm)	SC	SD	SE	SF	SG		SH in-lbs	SJ	SK	SP	SQ	SR	ST	C	L
					Max	Min									
16	0.71 (18)	0.16 (4)	1.65 (42)	1.38 (35)	0.57 (14.5)	0.18 (4.5)	26	0.98 (25)	1.93 (49)	M3	1.34 (34)	0.24 (6)	0.16 (4)	1.46 (37)	5.87 (149)
20	0.89 (22.5)	0.14 (3.5)	1.89 (48)	1.57 (40)	0.57 (14.5)	0.18 (4.5)	61	1.54 (39)	2.24 (57)	M4	1.50 (38)	0.32 (8)	0.20 (5)	1.65 (42)	6.65 (169)
25	0.79 (20)	0.10 (2.5)	2.46 (62.5)	2.03 (51.5)	0.57 (14.5)	0.18 (4.5)	104	1.97 (50)	3.03 (77)	M6	1.97 (50)	0.47 (12)	0.39 (10)	2.09 (53)	7.48 (190)

inches (mm)
SH = max. energy absorption

32 to 63mm bore sizes

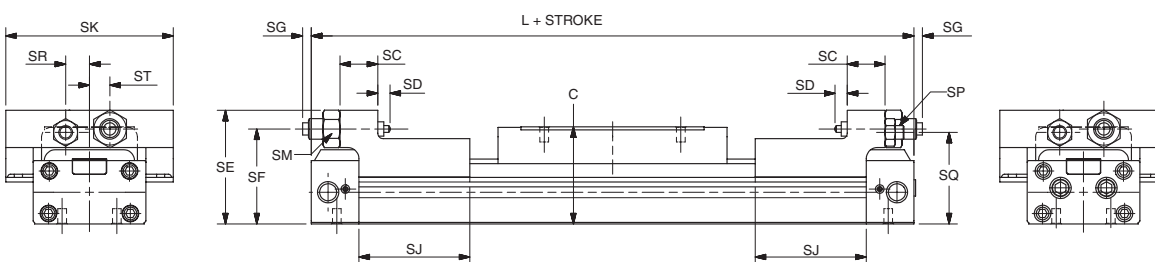

Bore (mm)	SC	SD	SE	SF	SG		SH in-lbs	SJ	SK	SP	SQ	SR	ST	C	L
					Max	Min									
32	0.87 (22)	0.28 (7)	2.62 (66.5)	2.19 (55.5)	1.06 (27)	0.67 (17)	226	2.56 (65)	3.86 (98)	M8	2.11 (53.5)	0.55 (14)	0.47 (12)	2.24 (57)	8.90 (226)
40	1.26 (32)	0.28 (7)	3.09 (78.5)	2.58 (65.5)	1.34 (34)	0.94 (24)	608	2.56 (65)	4.41 (112)	M10	2.50 (63.5)	0.67 (17)	0.47 (12)	2.64 (67)	9.61 (244)
50	1.50 (38)	0.32 (8)	3.90 (99)	3.15 (80)	2.17 (55)	1.77 (45)	1042	2.76 (70)	5.35 (136)	M12	3.05 (77.5)	0.87 (22)	0.67 (17)	3.23 (82)	10.16 (258)
63	1.50 (38)	0.32 (8)	4.41 (112)	3.68 (93.5)	1.73 (44)	1.34 (34)	1042	2.76 (70)	6.22 (158)	M16	3.50 (89)	0.98 (25)	0.79 (20)	3.74 (95)	11.65 (296)

inches (mm)
SH = max. energy absorption



For inventory, lead times, and kit lookup, visit www.pdnplu.com

Positioning of stroke adjustment unit

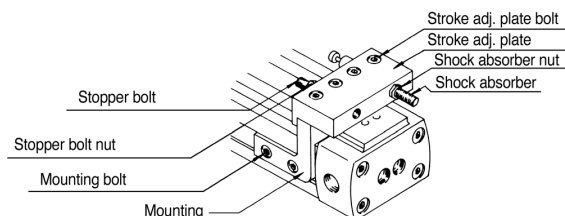

ø16-ø25

- (1) Moving the stroke adjustment unit.
The stroke adjustment unit can be moved by loosening the mounting bolts.
- (2) Locking of stroke adjustment unit.
After moving the stroke adjustment unit to the appropriate position, lock it there by tightening the mounting bolts to the torque values shown in Figure 1. Insufficient torque may cause the stroke adjustment unit to slip out of position.

Figure 1
Torque values for tightening stroke adjustment unit.

Bore Size	Tightening Torque	
	Mounting Bolt (lb-in)	Stroke adj. Plate Bolt (lb-in)
16mm	9-11	4-6
20mm	22-24	
25mm	46-50	22-24
32mm	195-213	-
40mm	390-415	-
50, 63mm	682-735	-

- (3) Stroke adjustment using the stopper bolt.
Adjust the stroke by loosening the stopper bolt nut and turning the stopper bolt. After adjusting the stroke, tighten the stopper bolt nut to the torque values shown in Figure 2. When adjusting the 16-25 mm cylinders, due to the small amount of clearance between the table and the stroke adjustment plate, adjust the stroke by moving the complete stroke adjustment unit.

Figure 2
Torque values for tightening stopper bolt nut and shock absorber nut.

Bore Size	Tightening Torque	
	Stopper Bolt nut (lb-in)	Shock Absorber Nut (lb-in)
16mm	10-11	12-16
20mm	22-24	26-35
25mm	73-84	40-53
32mm	195-213	66-89
40mm	390-425	195-266
50mm	682-735	487-620
63mm	1772-1914	487-620

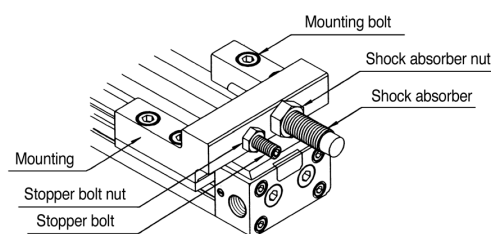

ø32-ø63

- (4) Adjustment of shock absorber.
Adjust the absorption energy of the shock absorber by changing the operating stroke of the shock absorber. This is done by loosening the shock absorber nut and turning the unit. When adjustment is complete, tighten the shock absorber nut to the torque values shown in Figure 2.
- (5) Notes on usage.
The shock absorber absorbs rated energy with rated stroke. The factory setting allows a small amount of shock absorber stroke before it bottoms out. Readjust the location of the shock absorber so that the complete stroke of the absorber is utilized.

Absorption energy as set at factory:
Small margin with stroke of shock absorber.

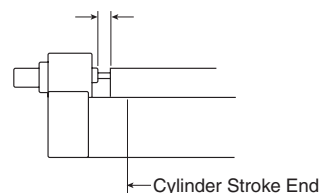

Adjust the position of the shock absorber until the plunger of the shock absorber is fully depressed.

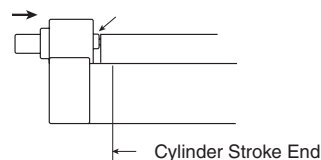

Rodless Pneumatic Cylinders
OSP-P Series
P1X Series
GDL Series
2002/P120 Series
P55 Electronic & Reed Sensors
Accessories
Part Number Index
Safety Guide, Offer of Sale



For inventory, lead times, and kit lookup, visit www.pdnplu.com

Parker Pneumatic

Rodless Pneumatic Cylinders
OSP-P Series
P1X Series
GDL Series
2002/P120 Series
P55 Electronic & Reed Sensors
Accessories
Part Number Index
Safety Guide, Offer of Sale



For inventory, lead times, and kit lookup, visit www.pdnplu.com



Rodless Pneumatic Cylinders
GDL Series

GDL Series - Rails & Cassettes

Features	112-113
Ordering Information / Stroke Lengths	114
Specifications	115
Dimensional Data	116
Accessories	117-118
Technical	119-123
Application Sheet	124

Rodless Pneumatic Cylinders
OSP-P Series
P1X Series
GDL Series
2002/P120 Series
P5S Electronic & Reed Sensors
Accessories
Part Number Index
Safety Guide, Offer of Sale



For inventory, lead times, and kit lookup, visit www.pdnplu.com

Features

GDL Series

Light, Smooth and FAST

Aluminum roller guides in a cutting machine for spectacle lenses. Both the work piece carriers and the motorized X - Y table axis are equipped with roller guides. The smooth operation and precision of the equipment ensures a fine cutting action.

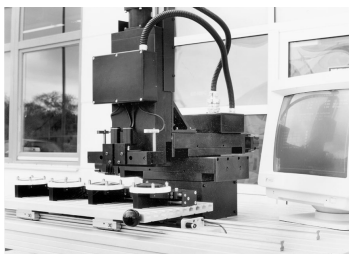

- Light weight (anodized aluminum)
- Smooth and quiet operation
- Speeds up to 10 m/s
- Acceleration/deceleration up to 40 m/s²
- Loading from any direction
- Permanently lubricated guidance system
- Broad product range in various series high performance, standard and stainless steel versions
- High load and moment capacities
- Very cost effective
- Flexible mounting dimensions

Aluminum roller guides in an automatic vibrator for flattening printed sheets of paper. To guarantee even pressure on the sheets of paper, the roller bridge is supported by precision roller guides.

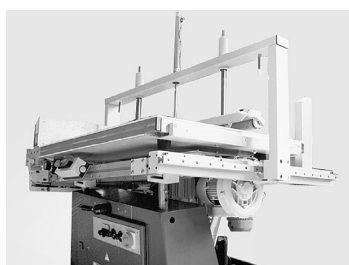

(Baumann company photo)

Handling units for medical equipment. Smooth, easy movement with guideline roller guides.



(Dräger company photo)

Aluminum roller guides in the sliding carriage of a machine for producing cables. The projecting arm of the carriage is guided by two double rails each with two roller cassettes and can be moved manually with minimal force because of the low friction properties.



(Kabelmat company photo)

Single rail and roller shoe versions of the aluminum roller guide in a handling arrangement for stacks of paper. Various fittings and limit stops for stacking are moved on two axes horizontally and vertically. The robustness and reliability of the roller guides allows for continuous operation under high load conditions.

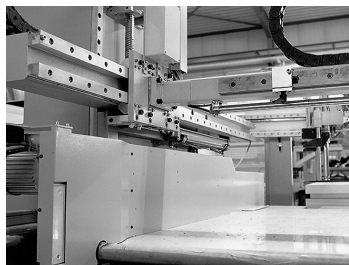

(Solms company photo)

Rodless Pneumatic Cylinders
OSP-P Series
P1X Series
GDL Series
2002/P120 Series
P55 Electronic & Reed Sensors
Accessories
Part Number Index
Safety Guide, Offer of Sale



For inventory, lead times, and kit lookup, visit www.pdnplu.com

GDL Linear Guides Offer a Variety of Series and Options – High Performance... “Smooth Guidance”

Aluminum roller guides provide smooth operation and high load carrying capacity for industrial automation.

By the use of lightweight aluminum components the moving masses are minimized, travel speeds are increased and actuation energy is saved.

Aluminum roller guides are designed to carry medium weight loads economically. Their smooth action and speeds up to 10 m/s make them ideal for widespread use in many areas of application.

Aside from a main featured High Performance guide, others such as the Standard, Corrosion Resistant, High Dynamics and Grease-free versions are also available.

Aluminum roller guides are available in sizes 12, 15, 20, 25, 35 and 45mm. Rail lengths are from 200 mm to 4000 mm. For longer travel lengths, guide rails can be butt-jointed together.

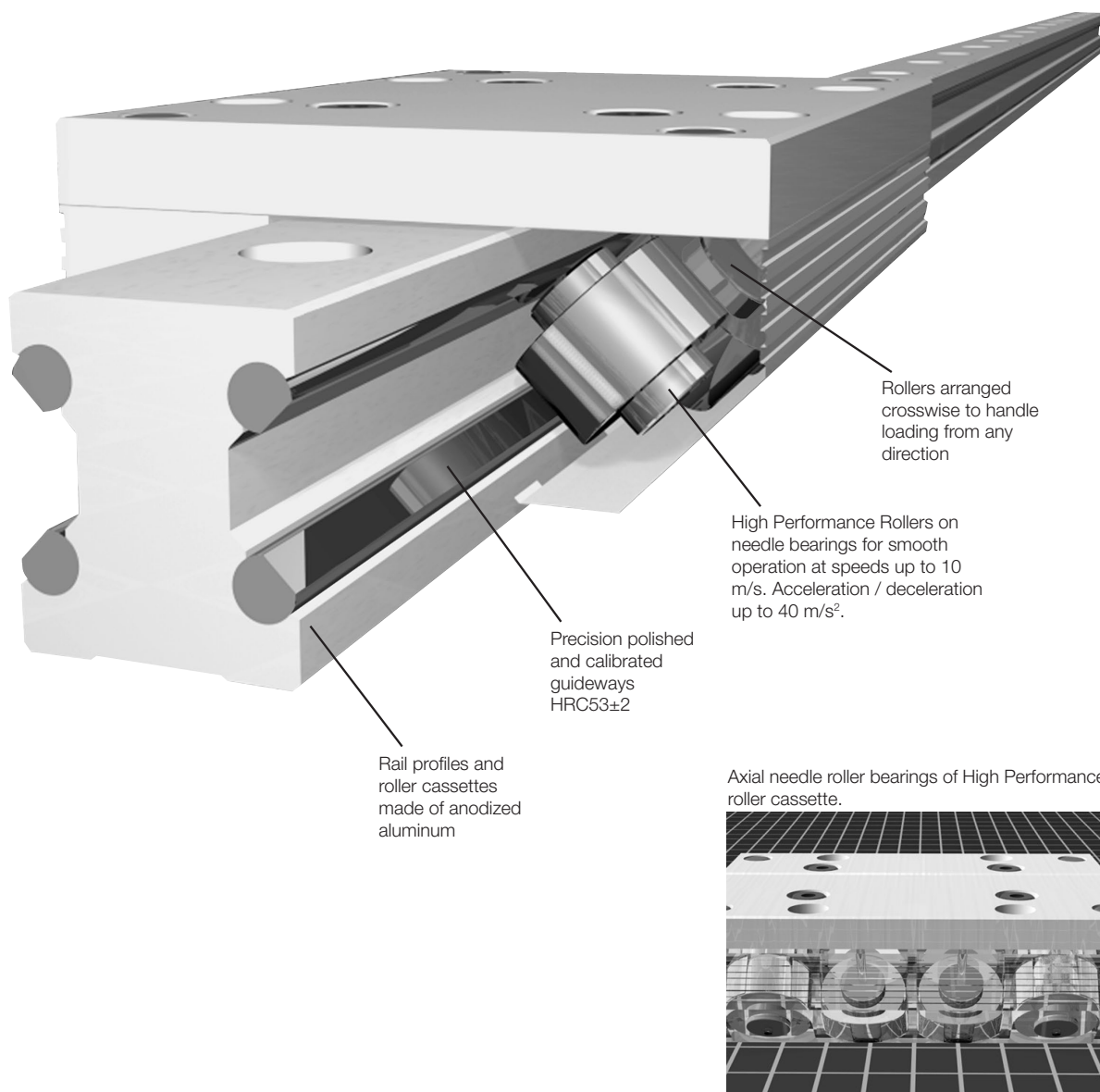

Rodless Pneumatic Cylinders
OSP-P Series
P1X Series
GDL Series
2002/P120 Series
P5S Electronic & Reed Sensors
Accessories
Part Number Index
Safety Guide, Offer of Sale



For inventory, lead times, and kit lookup, visit www.pdnplu.com

Rodless Pneumatic Cylinders GDL Series

Ordering Information

High Performance Series:

(Sizes FDC12HP-... thru FDC45HP-...)

The High Performance series is the basis for GDL's development, which is used in the majority of applications. High Performance guides consist of 8 axial needle roller bearings, running on precision polished and hardened alloy spring steel guideways. These guide bearings are grease packed and shielded, while offering the highest load and moment rating capacities within the GDL product line.

Standard Performance Series:

(Sizes FDC12SP-... thru FDC45SP-...)

The Standard Performance series is intended for minor loads and moments for particularly economical guidance solutions. Standard Performance guides consist of 8 radial ball roller bearings, running on precision polished and hardened alloy spring steel guideways. These guide bearings are grease packed and sealed, while offering the lowest load and moment ratings available within the GDL product line, with the exception of the Grease-Free and the Anti-Friction / Corrosion Resistant series. Standard Performance series is the second most commonly used GDL guides for various applications and also provides excellent running behavior.

Ordering Information for GDL Rails

1	2	3	4	5	6	7	8	9	10	11	12	13	14	15	16	17	18		
F	D	R	1	2	H	0	0	0	0	0	0	-	0	0	0	0	0		
Series FD Double Sided Rail Guide* (standard)		Rail R Standard		Rail Size 1 2" 1 5" 2 0" 2 5" 3 5" 4 5"		Guideway Material H High Performance Alloy Steel* (standard) S† Stainless Steel † Not available on rail size 12.		Coatings 0 Anodized Aluminum* (standard)		"L11" Dimension 00 Equal on Both Sides* (standard) ?? Actual Dimension (mm)**		Mounting Holes 0 Topside Thru Hole* (standard) 1 Underside Blind Thread Z Custom (consult factory)		Screw Covers 0 None* (standard) 1 Yes*		Long Rail Joining Option 0 None* (standard) 1 Keyed Butt Joint (size 25-45 only) 2 Unkeyed Butt Joint		Length (mm) - 0 0 0 0 0 0 Note: Maximum length is 4 meters on Size 12.	
** As measured from left side while viewing the depth groove line.																			
*Stocked Item																			

Ordering Information for GDL Cassettes

1	2	3	4	5	6	7	8	9	10	11	12	13	14	15	16						
F	D	C	1		H	P	-	0	0	0	0	0	0	0	0						
Series FD Double Sided Rail Cassette* (standard)		Cassette C Standard		Rail Size 1 2" 1 5" 2 0" 2 5" 3 5" 4 5"		Grease 0 High Performance* (standard) Z Custom (consult factory)		Lubrication Options 0 None* (standard) 1 Central Lube 2 Central Lube (no nipple) Z Custom (consult factory)**		Coatings 0 Anodized and Standard Hardware* (standard) 1 Anodized and Stainless Steel Hardware* Z Custom (consult factory)		Mounting Holes 0 Topside Threaded Thru* (standard) 1 Underside Hole Thru (unthreaded) 2 Underside Hole Thru (threaded)		Locking Mechanism 0 None* (standard) 1 "L" Ratchet Handle* 2 Star Grip Handle*		Adjustment 0 None* (standard) 1 Adjusted to Specific Rail*		Cassette Length 0 Normal Length* (standard) Z Custom (consult factory)**		Wiper Options 0 With Felt Wipers* (standard) 1 Without* 2 With Felt Wipers and Scrapers*	
*Stocked Item																					
**Minimum Order Quantity Required																					
* Locking mechanism only available on FD Series size 15 thru 45 with Axial Needle Bearing - High Performance - Alloy Steel.																					



For inventory, lead times, and kit lookup, visit www.pdnplu.com



Product Line Overview

Characteristic	Unit	Description
Full profile wipers		Rollershoes and cassette are provided with snap-on full profile wipers. The snap-on full profile wipers are easily replaceable with available wipers kits.
Acceleration and deceleration	m/s ² (ft/sec ²)	40 m/s ² maximum (131 ft/s ² maximum)
Guide installation		Possible in any position.
Drag adjustment set screw		Cassettes can be adjusted at the factory or by the customer. Rollershoes can be set-up by the customer to incorporate the drag adjustment set screw feature. The drag adjustment set screw components are supplied with each pair of rollershoes.
Standard lubrication		Lifetime lubrication with standard grease-packed roller bearings.
Speed	m/s (ft/s)	Up to 10 m/s (or up to 33 ft/s)
Bearing types		Steel axial needle, Specials on request (ex: anti-magnetic, grease free, high dynamics) - consult factory
Operating temperature	C (F)	-10°C to 80°C (14°F to 176°F) temperature range
Specials available		Custom length cassettes and rollershoes for 100 piece lots minimum. Keyed butt-jointed rail sections for continuous rail lengths of 3900mm and above. Solid continuous length rails up to 3900mm. Offset or non-standard "L11" dimensions on opposite ends of cut rails. Integrated metal scraper with standard full profile wiper currently available. Rail underside blind mounting holes.

Material specifications

Rail		Aluminum alloy
Guideways	Standard	High alloy spring steel HRC 53 +/- 2
	Corrosive resistant	Stainless steel guideway\ 46 HRC
Cassettes / rollershoes / top plates		Aluminum alloy
Rollers		Bearing steel / Stainless steel bearing steel

General Facts Pertaining to All Series:

Snap-on full profile wipers:	Rollershoes and cassettes can be provided with snap-on full profile wipers. The snap-on full profile wipers are easily replaceable with available wiper kits. See page 118 for respective wiper kit part numbers.
Cassette adjustment:	Cassettes can be adjusted at the factory or by the customer.
Fasteners:	Rollershoes and cassettes use ISO screw quality 8.8 and DIN 433 washers. ISO screw quality 8.8 is recommended for mounting the rails also. Special stainless steel fasteners can be requested as necessary.
Carrying Capacity:	See load and moment rating tables on next page for your guide series of interest.
Guide mounting position:	Optional.
Lengths:	For longer than standard rail lengths, see keyed butt-jointed rail option on page 118.
Lubrication:	GDL Aluminum Roller Guides are permanently lubricated with contained roller bearings grease.

See ordering information on previous page to define your desired GDL guide features for ordering.

Rodless Pneumatic Cylinders
OSP-P Series
P1X Series
GDL Series
2002/P120 Series
P5S Electronic & Reed Sensors
Accessories
Part Number Index
Safety Guide, Offer of Sale



For inventory, lead times, and kit lookup, visit www.pdnplu.com

Cassette with double sided rail

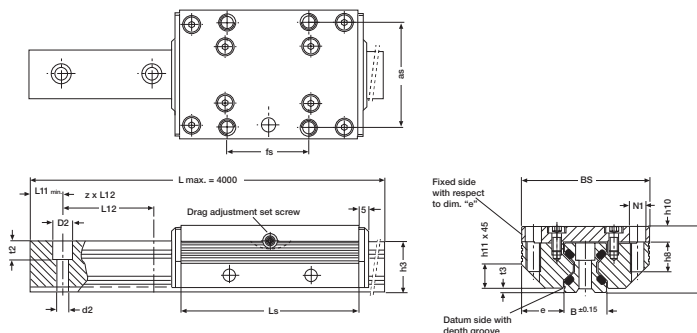

Both standard FDC version guides

Size	Length														L11 min.	L12	t2	t3	N1
	Ls	B	BS	h3	h9	as	d2	D2	e	fs	h8	h10	h11						
12	64	12.0	37	14.7	19	30	3.4	6	12.50	25	8	4.0	6	10	40	5.5	1.4	M4	
15	78	15.5	47	18.7	24	38	4.5	8	15.75	30	10	5.0	8	10	60	6.0	2.0	M5	
20	92	21.0	63	22.6	30	53	5.5	10	21.00	40	12	7.0	11	10	60	7.0	2.0	M6	
25	98	23.0	70	27.0	36	57	6.6	11	23.50	45	16	8.5	13	10	60	10.0	2.5	M8	
35	135	32.0	100	37.0	48	82	9.0	15	34.00	62	20	10.5	20	12	80	11.5	3.5	M10	
45	165	45.0	120	46.0	60	100	11.0	18	37.50	80	24	13.5	22	16	105	14.5	4.0	M12	

Dimensions (mm)

Both underside mounting hole FDC version guides (Ref. ordering instructions)

Size	Length														L11 min.	L12	t2	t3	N1
	Ls	B	BS	h3	h9	as	d2	D2	e	fs	h8	h10	h11						
12	64	12.0	37	14.7	19	30	3.4	6	12.50	29	8	4.0	6	10	40	5.5	1.4	M4	
15	78	15.5	47	18.7	24	38	4.5	8	15.75	34	10	5.0	8	10	60	6.0	2.0	M5	
20	92	21.0	63	22.6	30	53	5.5	10	21.00	40	12	7.0	11	10	60	7.0	2.0	M6	
25	98	23.0	70	27.0	36	57	6.6	11	23.50	45	16	8.5	13	10	60	10.0	2.5	M8	
35	135	32.0	100	37.0	48	82	9.0	15	34.00	62	20	10.5	20	12	80	11.5	3.5	M10	
45	165	45.0	120	46.0	60	100	11.0	18	37.50	90	24	13.5	22	16	105	14.5	4.0	M12	

Dimensions (mm)

Roll

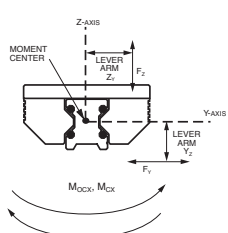

Pitch

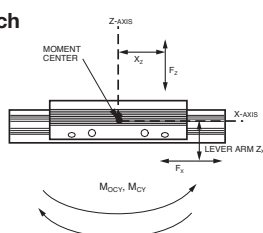

Yaw

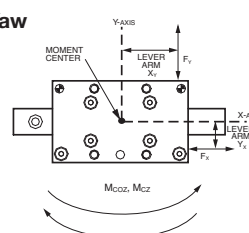

Load & moment rating capacities (for cassettes on double sided rail)

Dynamic Load Rating C (N)	Static Load Rating Co (N)	Static Moment Rating Capacities:			Dynamic Moment Rating Capacities:			Cassette Weight (kg)	Rail Weight (kg) per "M"	Cassette Series
		Roll Mocc (Nm)	Pitch Mocy (Nm)	Yaw Mocz (Nm)	Roll Mcx (Nm)	Pitch Mcy (Nm)	Yaw Mcz (Nm)			
High Performance Series										
2800	3000	27	43	43	25	40	40	0.1	0.4	FDC12HP-...
4200	3400	37	58	58	45	72	72	0.3	0.8	FDC15HP-...
5400	5400	76	111	111	76	111	111	0.4	0.9	FDC20HP-...
9000	10100	158	222	222	142	198	198	0.6	1.8	FDC25HP-...
12500	18000	423	559	559	294	388	388	1.5	3.2	FDC35HP-...
21200	25900	827	983	983	678	806	806	2.9	5.5	FDC45HP-...



For inventory, lead times, and kit lookup, visit www.pdnplu.com

GDL Aluminum Roller Guides

High performance cassettes with lock device

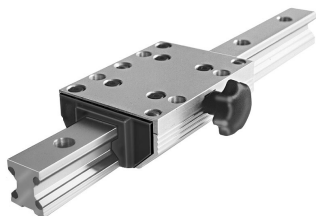

The locking cassette with star grip handle can be stopped at any desired location on the rail. The clamping device does not exert forces on the rail guideways.

The clamping device is used in fixtures which are movable manually, clamping and stop ledgers, feeding of tools and work pieces. Also available with L-ratchet handle.

Special cassette types

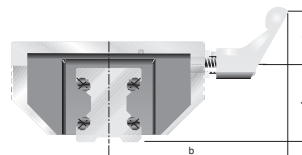
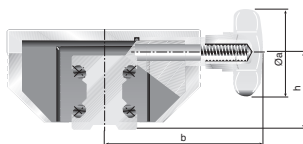

Star grip handle dimensions

Size	Øa	b	h	Clamp force	Part numbers star grip knob
12	N/A				
15	25	41	19.0	200	FDC15HP-00020000
20	25	49	23.0	250	FDC20HP-00020000
25	32	56	28.0	250	FDC25HP-00020000
35	50	83	38.5	350	FDC35HP-00020000
45	63	101	48.0	750	FDC45HP-00020000

L-ratchet handle dimensions

Size	l	b	h	Clamp force	Part numbers L-ratchet handle
12	N/A				
15	45	59.5	19.0	200	FDC15HP-00010000
20	45	67.5	23.0	250	FDC20HP-00010000
25	45	71	28.0	250	FDC25HP-00010000
35	63	96	38.5	350	FDC35HP-00010000
45	78	116	48.0	750	FDC45HP-00010000

Dimensions (mm), Force (N) with normal manual tightening.

End of stroke stop screws

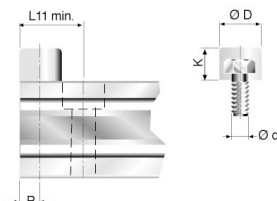
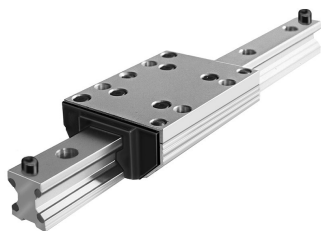

The stop screws are screwed into threads (option) on the guide rails. The end of stroke stopping energy is reduced by a rubber cap. With guide rails where the L11 is less than the standard minimum, we offset the mounting hole by half of its diameter.

Note: Customer must drill and tap the holes for the stop screws.

Size	Ød	ØD	K	L11 min.	P	Part number
12	M5	12	8	15.0	6.0	63504A
15	M5	12	8	16.0	6.0	63504A
20	M5	12	8	17.0	6.0	63504A
25	M6	15	10	20.5	7.5	63505A
35	M8	19	13	26.5	9.5	63506A
45	M10	24	16	33.0	12.0	63507A

Dimensions (mm)

GDL Accessories

Rail mounting screw covers

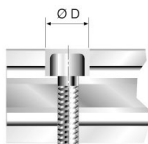
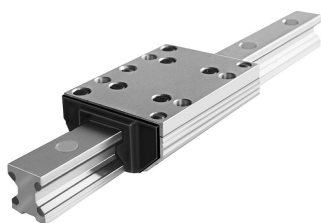

Material: Wear resistant plastic, resistant to oil and aging.

Mounting: Put a plastic plate on top and pound in uniformly. Remove residual burrs with a soft brush or fingernail.

Note: Use respective part numbers for ordering separately or include in rail part number.

Size	Cylindrical screw DIN912	Ø D	Part number
12	M3	6	87752A
15	M4	8	42074FIL
20	M5	10	87754A
25	M6	11	87755A
35	M8	15	6973
45	M10	18	87757A

Dimensions (mm)

Rodless Pneumatic Cylinders
OSP-P Series
P1X Series
GDL Series
2002/P120 Series
P55 Electronic & Reed Sensors
Accessories
Part Number Index
Safety Guide, Offer of Sale



For inventory, lead times, and kit lookup, visit www.pdnplu.com

Rodless Pneumatic Cylinders
OSP-P Series
P1X Series
GDL Series
2002/P120 Series
P55 Electronic & Reed Sensors
Accessories
Part Number Index
Safety Guide, Offer of Sale

GDL Aluminum roller guides with wipers

Version with wipers

Integrated into an additional cover, a felt wiper is saturated with oil. Although dependent on the degree of contaminants, these wipers last for some 6000km, after which the felt wipers can either be washed or replaced.

For optimal cassette rolling performance, all holes in the guide rails should be filled with the plastic rail mounting screw covers.

Cassette with full profile snap-on wipers

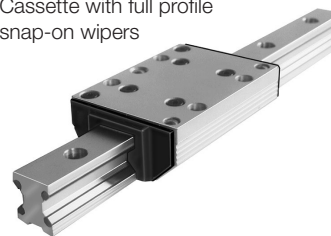

Part numbers for replacement wiper kits

FDC Series and Size	Respective Part Number
12	FDC12-WIPER-KIT
15	FDC15-WIPER-KIT
20	FDC20-WIPER-KIT
25	FDC25-WIPER-KIT
35	FDC35-WIPER-KIT
45	FDC45-WIPER-KIT

Full profile snap-on wiper

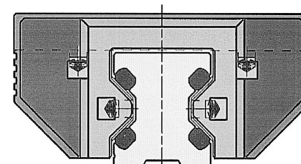

GDL's keyed butt-jointed rail option

GUIDELINE rails can be precisely fastened together using a factory offered keyed butt-joint option for continuous rail lengths, as shown in Figures 1 & 2.

Two rail sections are clamped together with mating round bar stock pieces that seat tangent to both rail section guideways on each side of the rail. While the rail sections are clamped together, a keyway slot is machined in the top and bottom sides of the rail, across the butt-joint. Screw holes are then drilled through the rail inside the keyway slot, so the opposing keyways can be drawn together tightly with screws. The round bar stock clamp is then removed, providing a rigid and well aligned keyed butt-joint.

The keyed butt-joint option provides optimum alignment of all guideways from one rail section to the next. This allows for optimum "smooth" guidance of the cassette bearings, while crossing rail butt-joints.

The keyed butt-jointed rail option is currently available in the FDR version 25, 35, & 45 mm rail sizes. For a keyed butt-joint on rail sizes 25, 35 or 45 mm, specify P/N:# GDL-BJK

Consult factory for other size possibilities.

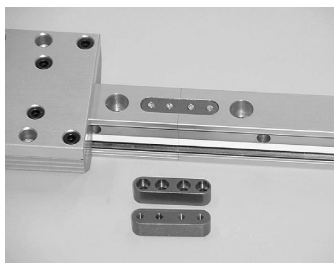

Figure 1



Figure 2

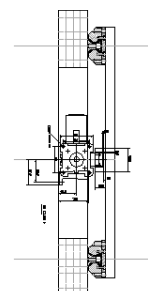

Figure 3

GDL linear guides couple well with various structural aluminum extrusions and Parker OSP-P actuators. Mounting can be easily accomplished using standard fasteners and mounting brackets. See Figure 3 above.



For inventory, lead times, and kit lookup, visit www.pdnplu.com

1. Features of the Guide System

Aluminum roller guides consist of a double sided rail and a roller cassette or two single sided rails and two roller shoes. Aluminum roller guide rails and cassettes are made of aluminum alloy. The rollers are very smooth running on precision polished guideways made of high alloy spring steel. The special cross pattern orientation of the running rollers provides high load and moment capacity in all directions.

Their special features are: light weight, small dimensions, and high speed of displacement. Aluminum roller guides are economical and universal handling components, which are mostly or all corrosion-resistant and available at a favorable price.

2. Size of the Guide System

To select the right guide size, first the moments and forces acting on the bearing have to be determined.

Recommended safety factors (with ISO screws quality 8.8):

- Thrust load S > 1.3
- Tensile load S > 4.0
- Moment load S > 6.0

3. Material

The basic body of GDL aluminum roller guides is made of aluminum alloy. The guideways consist of hardened, high alloy spring steel or of stainless steel. By using basic bodies of aluminum, the moved masses are reduced which allows light-weight construction requiring lower moving forces and reduced energy consumption. Still the integrated GDL system sustains high load and moment ratings.

4. Operating Temperature

GDL linear guides can be operated within a temperature range from -10° C up to 80°C. For other temperatures, please consult factory.

5. Screwed Connections

GDL linear guides are fixed to the mating structure by the mounting holes in the rails and the cassettes. ISO screw quality 8.8 should be used with DIN 433 washers.

To secure the screwed connections, we recommend that suitable locking means be utilized as necessary.

Mounting screw torque specifications:

Screw	Quality 8.8 [Nm]
M3	1.1
M4	2.5
M5	5.0
M6	8.5
M8	21.0
M10	41.0
M12	71.0

6. Wipers

The guideways of aluminum roller guides are equipped with wipers to protect against coarse environmental contamination.

Rodless Pneumatic Cylinders GDL Series

7. Slide Resistance / Adjustment

Follow the steps on how to adjust GDL cassettes to the rail.

The new GDL catalog has many changes due to an expanded product line. The change to feature descriptive part numbering was done to accommodate all current and future offerings of the GDL product. The goal is to have standard features and options available, for a perfect fit into your application.

Included in the chart below are hex sizes, drag resistance and torque ratings for adjusting the cassette.

GDL Chart

	FDC 12	FDC 15	FDC 20	FDC 25	FDC 35	FDC 45
Top plate hex (mm)	2	3	4	4	5	6
Top plate torque (in lbs)	n/a	22.1	44.3	44.3	75.2	186
Adjustment hex (mm)	1	3	3	4	4	4
Drag resistance (oz) HP, HC, GF, VA	1.8-7.9	3.6-10.8	5.4-16.2	7.2-21.6	10.8-32.4	12.6-37.7
Drag resistance (oz) SP & SC	.7-1.8	1.8-3.6	3.6-7.2	5.4-10.8	7.2-14.4	9-18
Drag resistance (oz) HD	n/a	n/a	n/a	9-18	14.4-25	18-28.7

7.1 GDL Adjustment Procedure

Do not measure sliding resistance with wipers on.

- 1) Lay the rail out on the flat surface with the datum line facing away from you. Anchor the rail to keep it from shifting when sliding resistance is applied to the cassette.

The datum line is a reference groove on one side of the rail.

- 2) Set the roller cassette on the rail with the adjustment screw facing towards you, while the datum line on the rail is away from you. Do not install the wipers on the cassette yet.

Do not install the wipers yet.

- 3) Make sure the four bolts on the adjustable side of the cassette are slightly loose and the bolts on the fixed side are tight before adjusting the drag screw.

One side of the cassette is fixed and the other side is floating.

- 4) The drag hex screw is located on one side of the cassette. Adjust the screw in for more drag and out for less. Do not try to adjust cassette with top plates bolts tight.

See the chart for drag adjustment hex screw size.

- 5) Adjust the drag on the cassette by sliding as it slides down the rail. Feel for an even amount of resistance as you turn the hex screw in and out.
- 6) Tighten down the top plate bolts to the proper torque specification. The tightening of the top plate bolts will add some resistance. If necessary, the adjustment procedure can be repeated for better sliding resistance for your application.

See the chart for top plate hex size and torque rating.

- 7) If the adjustment is done without a scale, it should move evenly. Some examples of improper adjustment are: If the

Rodless Pneumatic Cylinders
OSP-P Series
P1X Series
GDL Series
2002/P120 Series
P55 Electronic & Reed Sensors
Accessories
Part Number Index
Safety Guide, Offer of Sale



For inventory, lead times, and kit lookup, visit www.pdnplu.com

Catalog 0961-1
Technical Data

Rodless Pneumatic Cylinders

OSP-P Series

P1X Series

GDL Series

2002/P120 Series

P5S Electronic & Reed Sensors

Accessories

Part Number Index

Safety Guide, Offer of Sale

cassette “hops”, it is too tight. If it is too loose, the top plate of the cassette will have play. Try to be in the middle.

- 8) To check your settings use a pull or push style scale. Slide the cassette down the entire rail at an even speed, measuring the drag resistance. Your highest drag rating should be referenced when looking at the chart.

See the chart for drag resistance ratings for the size and type of cassette.

- 9) Install the clip on wipers. The wipers will add between 1-3 ounces of resistance. The wipers do not add any additional roller preload to the rail.

The clip on wipers can be installed at this time.

7.2 Double Sided Rail and Cassette

Aluminum roller guides are adjusted in such a way that the required stiffness under load is obtained. If self adjustment is preferred, we recommend that you measure the slide resistance as shown below. Before doing so, the mating structure should be checked for dimensional accuracy and flatness.

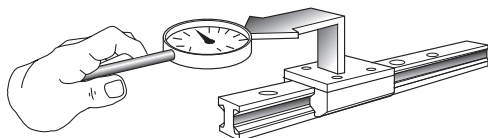

The cassettes which are mounted on the rails are adjusted clearance-free, without play. This adjusting method is required at the point on the rail where the cassette travels with the least slide resistance. Adjustment is completed in the non-loaded condition. The tolerances below refer to this condition.

Slide resistance adjustment tolerance [N]

Series	FDC_HP, FDC_HC,					FDC_SP, FDC_SC					FDC_HD				
	FDC_AM	FDC_GF	FDC_VA												
Size	12	15	20	25	35	45	12	15	20	25	35	45	25	35	45
Adjust. Value	0.5	1.0	1.5	2.0	3.0	3.5	0.2	0.5	1.0	1.5	2.0	2.5	2.5	4.0	5.0
Max. Value	2.0	3.0	4.5	6.0	9.0	10.5	0.5	1.0	2.0	3.0	4.0	5.0	5.0	7.0	8.0

All values are without wipers

Tolerances in the guide system may cause slight variations in the slide resistance, when the adjusted cassette is moved along the guide rail.

7.3 Double Sided Rail and Roller Cassette

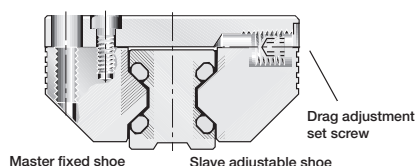

To change the clearance setting, first the slave adjustable shoe screws on the cassette top plate are slightly loosened.

Rodless Pneumatic Cylinders GDL Series

Afterwards, the drag adjustment set screw is turned to increase or decrease slide resistance of the cassette. Turning the drag adjustment set screw effects a displacement of the roller shoe in relation to the cassette top plate.

After re-tightening of the cassette top plate, the slide resistance can be checked. This procedure can be repeated until the desired slide resistance is achieved.

7.4 Rails and Rollershoes

When installing, it is important to distinguish between the master fixed side and the slave adjustable side rollershoe and rail. The rail on the master fixed side is aligned to the mating structure and fastened securely by all screws.

The rail on the slave adjustable side should be lightly tightened and movable with light force during initial alignment of parallel rails. Gauge blocks should be used between the parallel rails, by locating off the aligned and mounted master rail, in order to align the slave rail parallel to the master rail. Slave rail mounting bolts should be tightened as the slave rail is aligned at each bolt position. See paragraph 11.3 for further instructions on mounting parallel single sided rails.

7.5 Centering Groove on the Master Fixed Shoe and Custom Top Plate

Each pair of rollershoes are provided with centering grooves for optimum alignment to their mating top plate during mounting. One rollershoe should be designated as the master fixed rollershoe, even though both are designed with a centering groove on their top surface. The other shoe will serve as the slave adjustable side rollershoe. The mating customized top plate should be machined with a centering shoulder according to the following data.

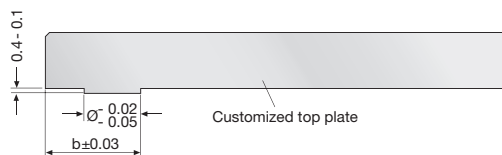

Size	a	b
12	4,5	9,6
15	5,0	12,6
20	7,5	16,1
25	10,5	17,6
35	12,5	26,1

7.6 Adjusting Cassette Built with Rollershoes and Custom Top Plate

The centering shoulder on the top plate should be assembled with its respective fixed rollershoe centering groove and securely torqued to recommended specification. See cassette screw torque specifications under step 5, on previous page.

Assemble the adjustable rollershoe to the top plate also, parallel to the fixed rollershoe on the same side of the top plate. Its fasteners should be lightly tightened so that the adjustable rollershoe can be moved with light finger pressure.



For inventory, lead times, and kit lookup, visit www.pdnplu.com

Catalog 0961-1
Technical Data

As assembled cassette can then be slid onto parallel rails, while keeping the fixed rollershoe on the master fixed rail side. The incorporated drag adjustment set screw can then be turned clockwise to remove cassette play, or counter clockwise to reduce slide resistance while maintaining zero play.

Once the desired slide resistance is achieved with no cassette play, the adjustable rollershoe fasteners can also be torqued to specification.

8. Running accuracy

The running accuracy is measured from the top plate surface of the cassette, to the ideal straight line of travel. Running accuracy of the cassette to the rail is +/- .03mm (.0012") per meter, granted no greater than (.0024") straightness deviation per meter is maintained when mounting the rail.

9. Contact and support surfaces

The contact and support surfaces have a substantial influence on functioning and precision of linear guides. Depending on the functional requirements of the system, the mating structure has to be machined with the corresponding degree of precision.

Machining errors on the mating structure will otherwise add to the running error of the guide system. In order to assure troublefree functioning, we recommend that a max. straightness deviation of $\leq 0.1 \text{ mm}$ (.0039") per running meter be maintained when mounting the rail.

10. Design hints

10.1 Parallel double sided rails and cassettes

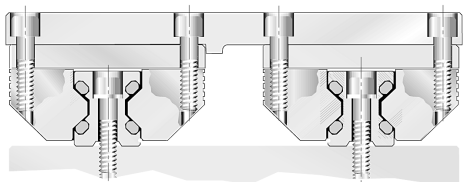

The master fixed rail should always be established straight and true first, within the maximum straightness deviation specified in paragraph 9. With parallel rail arrangements, both rails should be mounted on the same mounting surface elevation and treated with equal surface preparation and tolerancing practices. Precise alignment in terms of spacing, parallelism and height is very important.

When coupled parallel to a driving actuator system, the adjustable side of the cassette should be placed on the side closest to the driving actuator. This will minimize driving actuator torque transferred to the adjustable side of the cassette.

11. Guide mounting instructions

The useable load capacity is influenced by the connection between the guide elements and the mating structure. For this reason, a flat, straight and solid secure mounting surface should be provided. Adequate support of qualified loads and moments can then be achieved, along with desired running accuracy.

11.1 Mounting Double Sided Rails and Cassette

Depending on the load situation, certain double sided rails

**Rodless Pneumatic Cylinders
 GDL Series**

should either be screwed or screwed and dowelled, and respectively put into grooves or against a shoulder.

The rails can be secured best against shoulders and are screwed or screwed and dowelled to the mating structure.

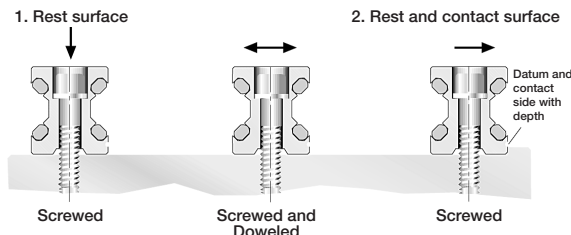

After final adjustment of rail straightness and parallelism, the rail mounting screws are tightened starting in the middle of the rail length. Rail mounting bolts should be torqued to specification by alternating between each bolt. The installer should start with the bolt in the center of the rail length and proceed by alternating between each bolt left of center and each bolt right of center, while working towards both ends of the rail.

Afterwards, the cassette should be moved back and forth along the total stroke distance of the rail. If the cassette travels smoothly, the mounting process can proceed or be completed.

11.2 Mounting Parallel Double Sided Rails and Cassettes

With parallel double sided rail arrangements, we recommend that the master fixed rail side and slave adjustment rail sides of the guide system be identified. This allows optimum tolerances in parallelism to be achieved best by adjusting the slave adjustable rail, parallel to the master rail. The master fixed rail side should be mounted first to achieve the initial line of straight travel.

The example below displays a convenient method for adjusting the slave adjustable rail parallel to the fixed master rail. Once the cassette travel is smooth, without play, one can proceed with rail mounting.

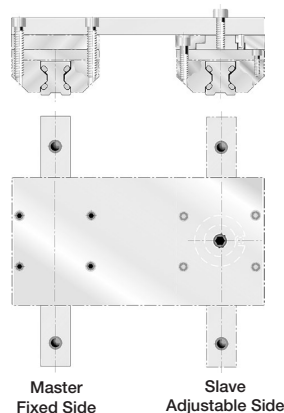

Note that the top plate spanning across the cassettes on opposite rails is completely bolted down to the cassette on the master fixed side only. The top plate end over the slave adjustable side is only bolted in one location, in the center of the slave adjustment side cassette. With one bolt holding the

Rodless Pneumatic Cylinders
OSP-P Series
P1X Series
GDL Series
2002/P120 Series
P55 Electronic & Reed Sensors
Accessories
Part Number Index
Safety Guide, Offer of Sale



For inventory, lead times, and kit lookup, visit www.pdnplu.com

Technical Data

Rodless Pneumatic Cylinders

top plate to the slave adjustment side cassette, this cassette can pivot while the slave adjustable rail self-aligns parallel to the fixed master rail side. The floating top plate setup is stroked along the entire rail length, to establish the parallelism between the two rails.

Calibrated gauge blocks can also be used to establish equal integrity in rail parallelism. The installer should seat and temporarily clamp short pieces of precision ground round stock, tangent to the two guideways on the inside of each rail.

OSP-P Series

Rail Size	Precision Round Stock Sizes Ø mm
12	11
15	11
20	14
25	16
35	27
45	35

P1X Series

The calibrated gauge blocks can then be used, to locate off the precision round stock on the master fixed rail, in order to set the slave adjustable rail parallel. The gauge blocks are then locating the same way that the floating top plate is, by referencing both the master and slave rail guideway surfaces to establish parallelism.

Once the slave adjustable rail has been self-aligned, its bolts should also be torqued to specification in the order mentioned in paragraph 11.1. The top spanning across both cassettes on opposite rails, can then be securely fastened using all cassette mounting bolt holes.

GDL Series

2002/P120 Series

12. Keyed Butt-jointing of Rail Sections
12.1 Rail Hole Spacing

Butt-jointed rails over L = 4000 mm are sectioned together according to the GDL standard. See "GDL's Keyed Butt-Jointed Rail Option" on page 118. Butt-jointed rails sections are cut so that the standard rail mounting hole spacing is maintained across all butt-joints.

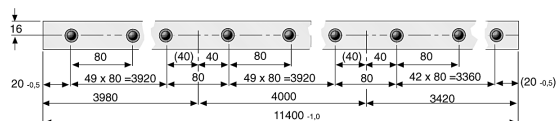

Keyed butt-jointed rails are usually shipped completely assembled, but sometimes must be shipped partially assembled, due to shipping length limitations and shipping care. Partially assembled butt-jointed rails are supplied with a butt-jointing clamping fixture and the keyways and screws for fastening rail section together.

12.2 Mounting of butt-jointed rails

Clean mounting surfaces, then place rail sections loose on the guide path, one behind the other. Lay the rails in their correct sequence of the system design (i.e.: 1, 2, 3, 4...etc.). The orientation of the depth groove on the lower surface of the rail should always be on the same side for all rail sections being butt-jointed.

**Rodless Pneumatic Cylinders
GDL Series**

Any non-assembled rail sections should be aligned with the factory supplied butt-joint clamping fixture as displayed below.



See explanation of "GDL's Keyed Butt-Jointed Rail Option" on page 118.

Once all rail sections are assembled, the complete guide path can be aligned and fastened. Alignment and fastening should be conducted according to the applicable guide arrangement and steps previously described in this technical information section.

P55 Electronic & Reed Sensors

Accessories

Part Number Index

Safety Guide, Offer of Sale



For inventory, lead times, and kit lookup, visit www.pdnplu.com

Units Conversion Tables

Force Conversions:

Multiply	By Conversion Factor	Result
pound-force	4.448	Newton
Newton	0.225	pound-force
kilogram-force	9.807	Newton
Newton	0.102	kilogram-force

Mass Conversions:

Multiply	By Conversion Factor	Result
ounce	28.349	gram
gram	0.035	ounce
kilogram	35.279	ounce
gram	0.001	kilogram
pound	0.453	kilogram
kilogram	2.205	pound

Velocity conversions:

Multiply	By Conversion Factor	Result
mile/hour	1.609	kilometer/hour
kilometer/hour	0.621	mile/hour
feet/second	0.305	meter/second
meter/second	3.281	feet/second
inch/minute	0.025	meter/minute
meter/minute	39.370	inch/minute

Acceleration Conversions:

Multiply	By Conversion Factor	Result
feet/section ²	0.305	meter/second ²
meter/second ²	3.281	feet/section ²
inch/section ²	0.025	meter/second ²
meter/second ²	39.370	inch/section ²

Bending Moment or Torque Conversions:

Multiply	By Conversion Factor	Result
pound-foot	1.356	Newton-meter
Newton-meter	0.737	pound-foot
Newton-meter	0.102	kilogram-meter
Kilogram-meter	9.807	Newton-meter

Length conversions:

Multiply	By Conversion Factor	Result
inch	25.4	millimeter
millimeter	0.039	inch
inch	0.025	meter
meter	39.370	inch
foot	0.305	meter
meter	3.281	foot

Rodless Pneumatic Cylinders
OSP-P Series
P1X Series
GDL Series
2002/P120 Series
P55 Electronic & Reed Sensors
Accessories
Part Number Index
Safety Guide, Offer of Sale



For inventory, lead times, and kit lookup, visit www.pdnplu.com

GDL Application Sheet

Distributor: _____ End-User: _____

Salesperson: _____

Phone: _____ Fax: _____ e-mail: _____

Other Information: _____

Rodless Pneumatic Cylinders
OSP-P Series
P1X Series
GDL Series
2002/P120 Series
P55 Electronic & Reed Sensors
Accessories
Part Number Index
Safety Guide, Offer of Sale

Roll

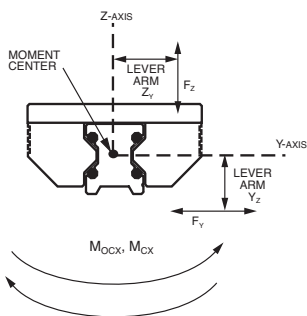

Roll load _____

X - Distance _____

Y - Distance _____

Z - Distance _____

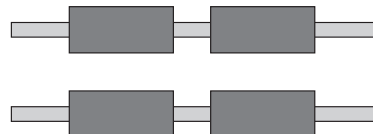

Length of rails _____

Distance between rails _____

Distance between cassettes on each rail _____

Pitch

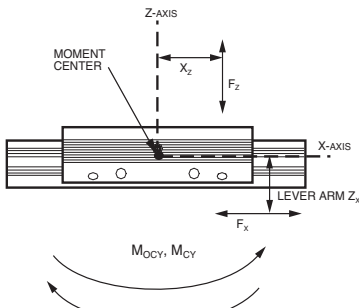

Pitch load _____

X - Distance _____

Y - Distance _____

Z - Distance _____

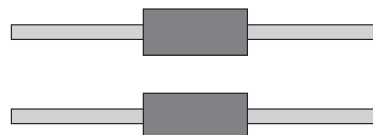

Technical Data:

Stroke _____

Horizontal _____

Vertical _____

Velocity / Speed _____

Acceleration _____

Load / Mass _____

Load Distances _____

Lifetime Desired _____

Environment:

(Dirt, Humidity...)

Yaw

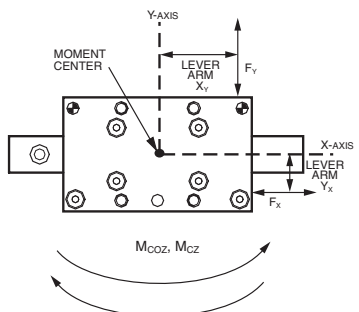

Yaw load _____

X - Distance _____

Y - Distance _____

Z - Distance _____



For inventory, lead times, and kit lookup, visit www.pdnplu.com



Rodless Pneumatic Cylinders 2002 / P120 Series

2002 and P120 Series

Features	126-131
Ordering Information	132
2002 Series Specifications	133
Technical Data - Basic Design	134-135
16mm	136-137
25mm, 32mm, 40mm, 50mm	138-139
Mounting	140
Technical Data - Joint Clamp	141-144
P120 Series Technical Data - Basic Design	145-146
40mm, 63mm, 80mm	147-148
Mounting	149
Magnetic Switches	
RS, ES Series	150
RST, EST Series	151-152
Spare Parts	
2002 Series	
16mm	153
25mm, 32mm, 40mm, 50mm	154
Kits & Parts	155
P120 Series	
Basic	156
Short Piston	157
Long Piston	158
Service Packs	159
Upgrade Kits	159

Rodless Pneumatic Cylinders
OSP-P Series
P1X Series
GDL Series
2002/P120 Series
P5S Electronic & Reed Sensors
Accessories
Part Number Index
Safety Guide, Offer of Sale



For inventory, lead times, and kit lookup, visit www.pdnplu.com

Features

Rodless Pneumatic Cylinders
OSP-P Series
P1X Series
GDL Series
2002/P120 Series
P55 Electronic & Reed Sensors
Accessories
Part Number Index
Safety Guide, Offer of Sale

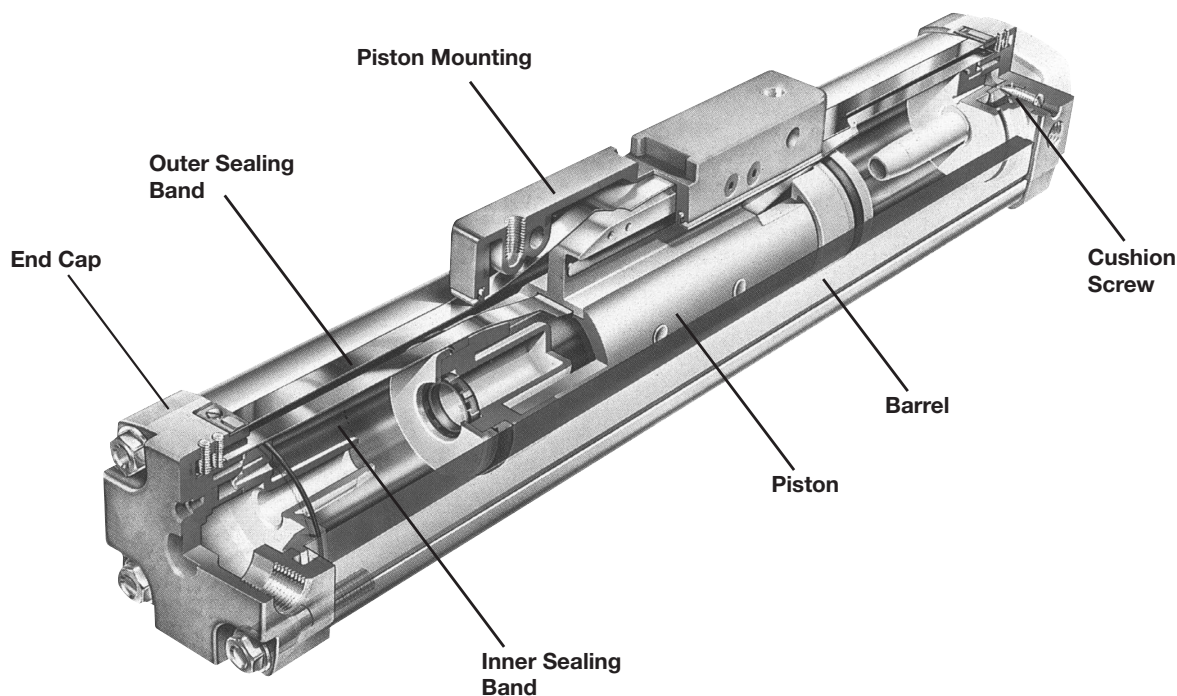

Features

1. The cylinder barrel of extruded anodized aluminum has a slot along its entire length. To provide rigidity the bore is eccentric to the outside diameter.
2. A flexible hardened stainless steel inner band running the entire length of the bore and passing through the piston provides a near-zero-leakage metal to metal seal. An outer band of the same material acts as a cover over the slot preventing foreign particles from entering into the cylinders interior.
3. The aluminum piston is fitted with synthetic bearing rings. The power transmission outward takes place through a positive, physical connection through the slot to the external piston mounting. This solid guide permits the acceptance of external forces and moments and minimizes frictional losses.
4. The extensive experience in the development and production of rodless cylinders, as well as the use of high quality components and materials, ensure a very serviceable design lending itself to high operating safety and optimum performance.
5. This unique design, using only 4 main components, makes cylinders reliable in operation and simple to maintain, providing long trouble free service.
6. Parker is the specialist in the rodless cylinder field, with the largest range of bore diameters and can offer the longest stroke lengths with application oriented accessories for cost effective designs. Parker has experience in all conceivable areas of industry, attributable to the thousands of applications in which rodless cylinders are used.



For inventory, lead times, and kit lookup, visit www.pdnplu.com

Features

Technical Benefits

Design Options

Parker Pneumatic cylinders can be supplied as a basic model, or as a basic model with external guides depending on the application requirements.

Cylinder Mountings

Various types of piston mounting are available including one which allows the cylinder to be inverted under adverse operating conditions thus protecting the sealing bands. End mounting brackets and midsection supports are also available.

Operating Pressure

Max. 120 PSI

End Of Stroke Cushioning

Adjustable cushioning is provided as standard and ensures the piston stops smoothly, even at high speeds.

Oil Free Operation

The permanent lubricating grease eliminates the need for regular oil mist lubrication and provides long service life. Cylinders can be used in applications where maximum cleanliness is required. (e.g. electronics pharmaceutical and food processing industries).

Slow Speed Applications

The construction of the rodless cylinder allows for a low friction characteristic permitting extremely slow traversing speeds. For speeds below 4 inches / second we recommend that "slow speed" lubrication is specified.

Temperature Range/Piston Speed

Standard Buna-N seals are suitable for temperatures from 15°F to +175°F. FKM seals are required for higher temperatures as well as for use when piston speeds exceed 5 ft./sec. Please contact the Parker Applications Department if the required operating temperature is above 175°F.

Magnetic Pistons

All Series 2002 cylinders are supplied as standard with magnetic pistons for proximity switch actuation.

Proximity Switches

Magnetically operated Hall Effect switches (IS) or Reed switches (RS) are available to sense piston position at any point over the entire stroke length.

Corrosive Environments

All screws are plated. In extreme applications stainless steel can be supplied. Special aluminum coatings are available for added protection against chemical or caustic wash down of equipment or in environments where corrosive gases are present.

Cylinder Loading

Values are based on shock-free duty and should not be exceeded during piston acceleration.

Note:

Seal life can be significantly influenced by extremes of speed, load and temperature which exceed the approved limits. Contact the Parker Applications Department for assistance with special applications.

All specifications are subject to change without notice.

Rodless Pneumatic Cylinders
OSP-P Series
P1X Series
GDL Series
2002/P120 Series
P5S Electronic & Reed Sensors
Accessories
Part Number Index
Safety Guide, Offer of Sale



For inventory, lead times, and kit lookup, visit www.pdnplu.com

Features

Circuit Configurations

Rodless Pneumatic Cylinders
OSP-P Series
P1X Series
GDL Series
2002/P120 Series
P55 Electronic & Reed Sensors
Accessories
Part Number Index
Safety Guide, Offer of Sale

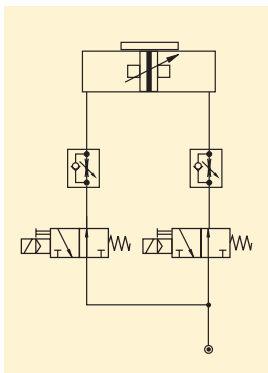

Circuit diagram for end of stroke application. Intermediate positioning is also possible.

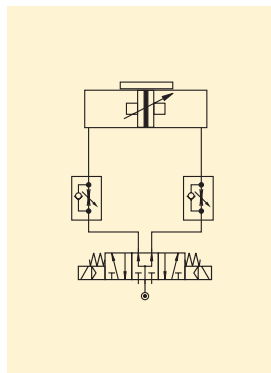

Circuit diagram for end of stroke application. Intermediate positioning is also possible.

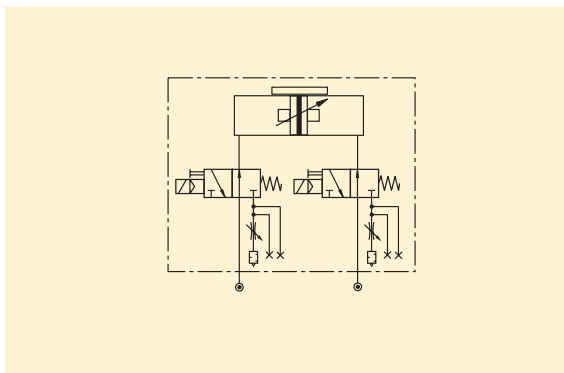

The optional integrated VOE Valves offer optimal control, and allow accurate positioning of intermediate positions and the lowest possible speeds.

The cylinder is controlled by two 3/2-way valves (normally open). The speed can be adjusted independently for both directions.

The cylinder is controlled by a 5/3-way valve (middle position pressurized). The speed can be adjusted independently for both directions.

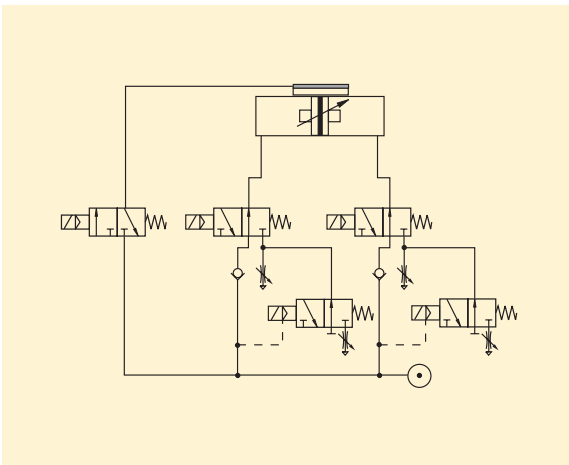

Fast/Slow speed cycle control with pneumatic brake for accurate positioning at high velocities. Additional 3/2-way valves with adjustable throttle valves at the exhaust of the standard directional control valves for two displacement speeds in each direction of the piston's travel.

The valve controlling the brake is activated after the slow speed cycle is activated.

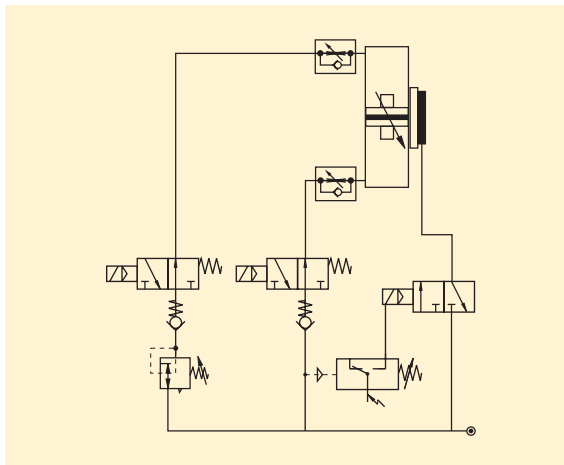

The combination of an OSP-cylinder with the passive MULTIBRAKE as shown here, allows accurate positioning and safety in case of loss of pneumatic air pressure.



For inventory, lead times, and kit lookup, visit www.pdnplu.com

Applications

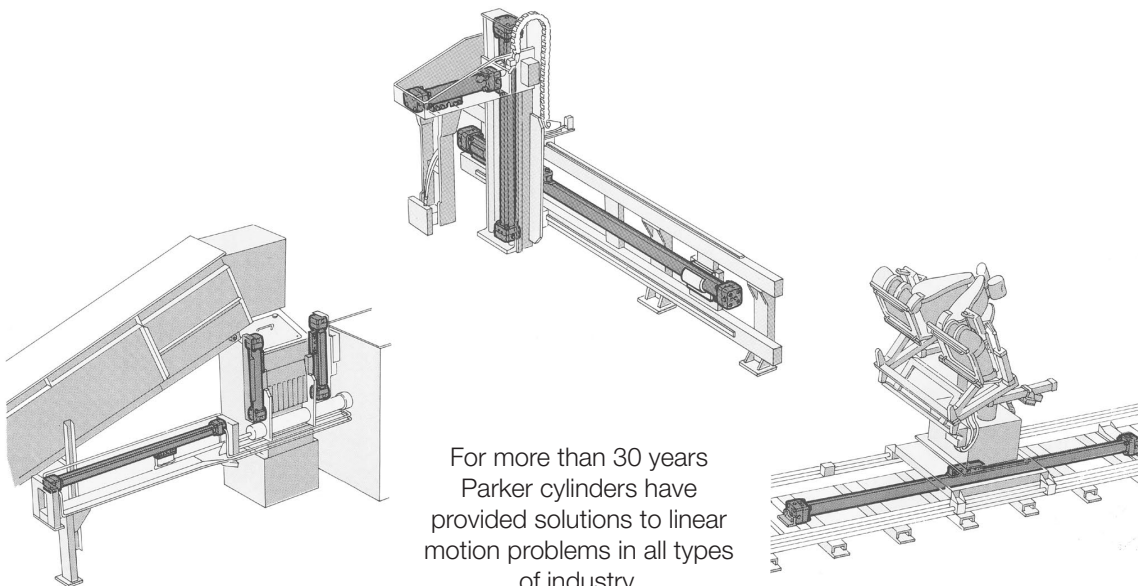

For more than 30 years Parker cylinders have provided solutions to linear motion problems in all types of industry.

Offering simple designs, easy installation, clean operation and maintenance free duty, Parker cylinders are suitable for a diversity of applications and environments.

For more information or assistance with your linear motion tasks, please call an authorized distributor or Parker direct.

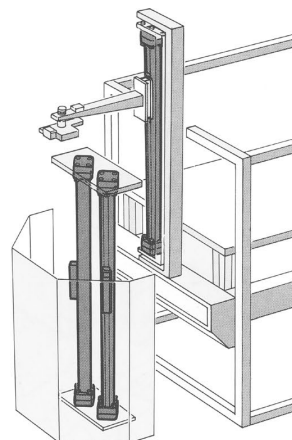
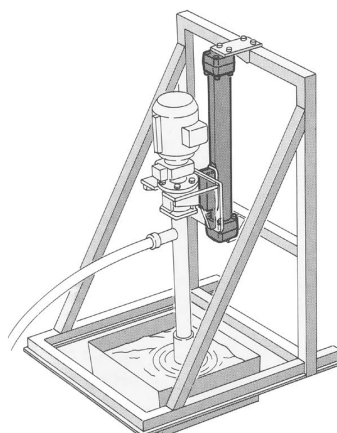
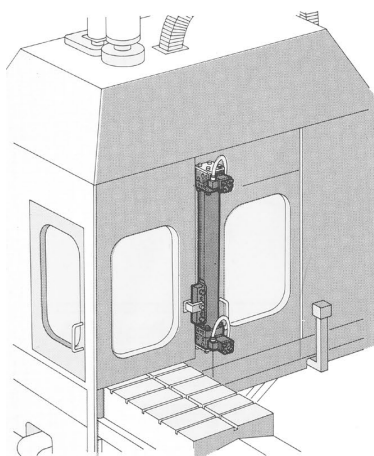

Rodless Pneumatic Cylinders
OSP-P Series
P1X Series
GDL Series
2002/P120 Series
P55 Electronic & Reed Sensors
Accessories
Part Number Index
Safety Guide, Offer of Sale



For inventory, lead times, and kit lookup, visit www.pdnplu.com

Features

Six Unique Advantages

Rodless Pneumatic Cylinders
OSP-P Series
P1X Series
GDL Series
2002/P120 Series
P55 Electronic & Reed Sensors
Accessories
Part Number Index
Safety Guide, Offer of Sale

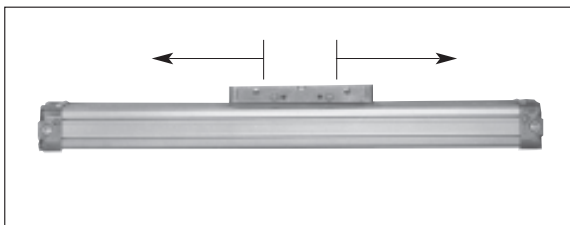

Equal Force and Speed

Equal piston area on each side of the piston allows for equal force and speed in both directions of travel. Additionally, the ability to “pneumatically lock” the piston at various points along the stroke is possible through the use of special valve configurations.

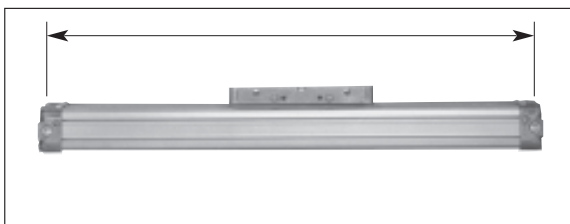

Any Length of Stroke

Infinitely variable strokes are available up to 480 inches and each cylinder is custom manufactured to customer requirements without incurring extended delivery times.

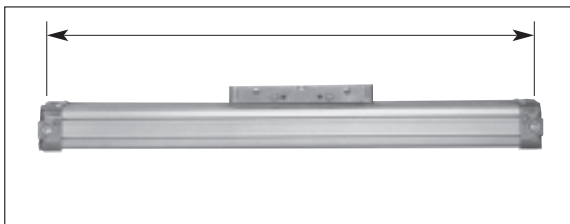

Space Saving

The lack of a piston rod allows for nearly half the space requirement of a “rod type” pneumatic cylinder. The result is a simpler, less costly installation reducing the amount of hardware and design time.

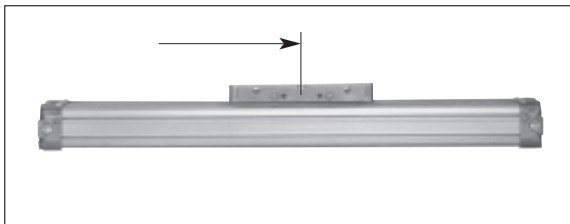

Accepts Cantilever Loads

The unique piston design and barrel rigidity allows the cylinder to accept high direct and bending moment loads without the need for additional support hardware.

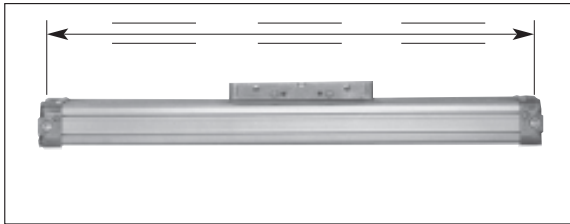

Self Guiding

The internal self-supporting characteristics of the rodless cylinder provides guidance of the piston throughout the stroke. High priced guidance mechanisms (roundway bearings, precision slideways, etc.) are not required.

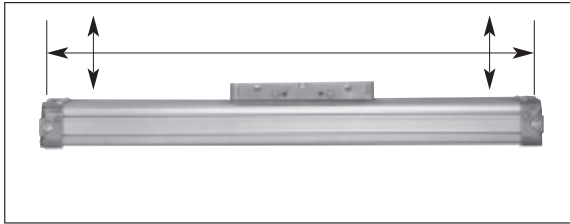

Inherent Rigidity

Integral strength and rigidity of the complete cylinder assembly will accommodate the heaviest of loads enabling the cylinder to form part of a structure or framework. This eliminates the need for expensive and bulky I-beams, channels and fabrications.



For inventory, lead times, and kit lookup, visit www.pdnplu.com

Features

The Product Range

Series 2002 - Basic Cylinder

Bore sizes (mm): 16, 25, 32, 40, 50

The basic cylinder series satisfies the support and guidance requirements of a great diversity of applications. Various mounting and control options are available for specific application needs.

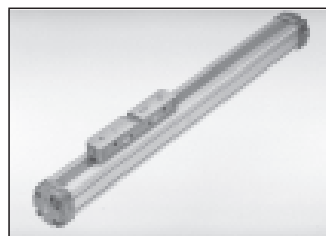

Series 2002 - Joint Clamp

Bore sizes (mm): 25, 32, 40, 50

Two cylinders mounted in a tandem configuration for increased load and force requirements. The arrangement enhances lateral support and bending moment capabilities.

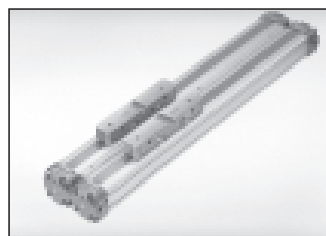

Series P120 - Basic Cylinder

Bore sizes (mm): 40, 63, 80

For high force and load requirements, the P120 series provides optimal strength and a unique package of options.

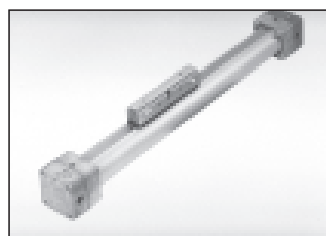

Rodless Pneumatic Cylinders
OSP-P Series
P1X Series
GDL Series
2002/P120 Series
P55 Electronic & Reed Sensors
Accessories
Part Number Index
Safety Guide, Offer of Sale



For inventory, lead times, and kit lookup, visit www.pdnplu.com

Ordering Information

Ordering Procedure

Rodless Pneumatic Cylinders
OSP-P Series
P1X Series
GDL Series
2002/P120 Series
P55 Electronic & Reed Sensors
Accessories
Part Number Index
Safety Guide, Offer of Sale

Series 2002

32-2020/20X50-B-M

Cylinder Bore Size:
16, 25, 32, 40 or 50

Configuration:
- = Single Cylinder
J = Joint Clamp Unit
C = Clean Room Cylinder

Piston Quantity:
20 = Single Piston
22 = Double Piston

End Cap Cushion Placement:
20 = Standard Cushion Location
30 = Cushion at Rear of Cap (31 for 50mm)
Note: Rear cushions are available on Ø25mm - Ø50mm only.

*Note: When entering total stroke length for 2220/2230 (double piston) cylinders be sure to first add the "CL" distance to the actual, effective stroke length. Enter this total in the cylinder part number. Follow the same procedure for pricing.

Prelube Specification (optional):
M = Standard
C = Cleanroom
F = Food Grade
S = Slow Speed

Seal Type:
B = Buna
F = FKM

***Stroke Length:**
Enter metric strokes followed by "mm" (i.e. 200mm)

Piston Mounting Type:
20 = Standard Mount
25 = Floating Mount
For Joint Clamp Cylinders:
24 = Platform Mount

Series P120

P124-S/20X50-B-M

Cylinder Series P120
Cylinder Bore Size:
4 = 40mm
6 = 63mm
8 = 80mm

Piston/Mount Configuration:
Short Piston
S/20 = Standard Mount
S/22 = Platform Mount
S/25 = Floating Mount
Long Piston
L/26 = Standard Mount
L/28 = Platform Mount

Prelube Specification (optional):
M = Standard
C = Cleanroom
F = Food Grade
S = Slow Speed

Seal Type:
B = Buna
F = FKM

Stroke Length:
Enter metric strokes followed by "mm" (i.e. 200mm)

Service Packs

Series 2002

SP32R-B-1 X S

Service Pack
Bore Size = 25, 32, 40, 50
B = Buna-N, F = FKM
1 = Single Piston
2 = Double Piston
Enter Stroke Length

Series P120

SP124-B-S X S

Service Pack
Bore Size: 124 = 40mm, 126 = 63mm, 128 = 80mm
B = Buna-N, F = FKM
S = Short Piston
L = Long Piston
Enter Stroke Length



For inventory, lead times, and kit lookup, visit www.pdnplu.com

2002 Summary

2020/20

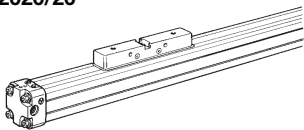

2020/20

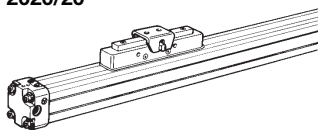

2020/20

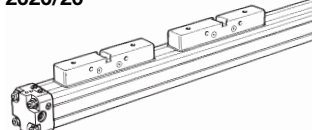

J2020/24

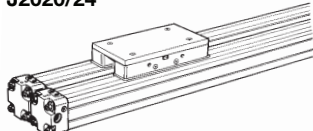

Series	Cyl Ø (mm)	Theoretical Force at 87 PSI (lbs. force)	Cushion Length (in.)	Max. Allowed Bending Moment Mx (in./lbs.)	Max. Allowed Bending Moment Mz (in./lbs.)	Max. Allowed Bending Moment My (in./lbs.)	Max. Allowed Load L (lbs.)
Series 2002 Single Piston	16	27	0.59	35	3	5	30
	25	66	0.55	132	9	27	65
	32	108	1.10	318	36	120	115
	40	169	1.42	575	53	156	195
	50	265	1.50	1017	98	312	270
Series 2002 Double Piston	16	27	0.59	81	6	9	60
	25	66	0.55	336	18	45	130
	32	108	1.10	720	72	600	230
	40	169	1.42	1320	106	792	390
	50	265	1.50	2304	196	1464	540
Joint Clamp Single Piston	25	132	0.55	264	115	54	130
	32	216	1.10	636	248	240	230
	40	338	1.42	1150	444	312	390
Joint Clamp Double Piston	50	530	1.50	2034	859	624	540
	25	132	0.55	672	230	90	260
	32	216	1.10	1440	496	1200	460
Series P120 Short Piston	40	338	1.42	2640	888	1584	780
	50	530	1.50	4608	1718	2928	1080
	40	169	1.26	528	36	72	170
Series P120 Long Piston	63	420	1.57	1776	72	216	370
	80	677	1.73	3192	144	420	590
	40	169	1.26	1200	72	216	170
Series P120 Long Piston	63	420	1.57	3984	144	660	370
	80	677	1.73	6372	288	1236	590

Rodless Pneumatic Cylinders
OSP-P Series
P1X Series
GDL Series
2002/P120 Series
P55 Electronic & Reed Sensors
Accessories
Part Number Index
Safety Guide, Offer of Sale



For inventory, lead times, and kit lookup, visit www.pdnplu.com

Rodless Pneumatic Cylinders
OSP-P Series
P1X Series
GDL Series
2002/P120 Series
P5S Electronic & Reed Sensors
Accessories
Part Number Index
Safety Guide, Offer of Sale

Loading Diagrams

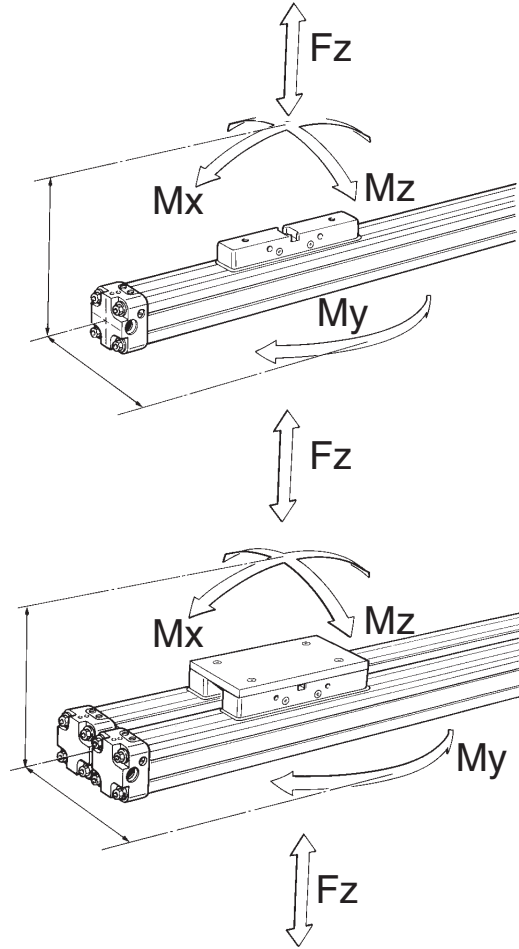

For inventory, lead times, and kit lookup, visit www.pdnplu.com

Series 2002 - Basic Cylinder

Bore sizes: 16mm, 25mm, 32mm, 40mm and 50mm. Stroke lengths available up to 480"

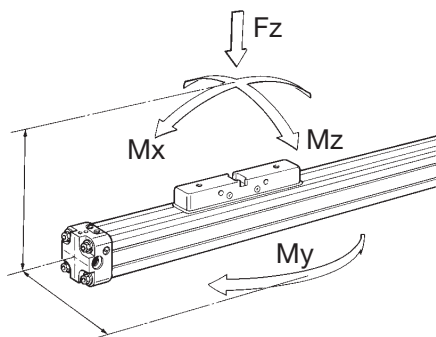
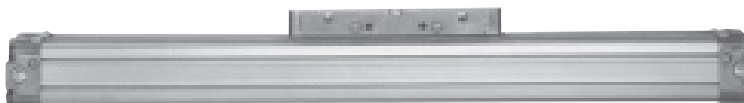

Loads, forces, moments

Cyl Ø (mm)	Theoretical Force at 87 PSI (lbs. force)	Cushion Length (in.)	Max. Allowed Bending Moment Mx (in./lbs.)	Max. Allowed Bending Moment Mz (in./lbs.)	Max. Allowed Bending Moment My (in./lbs.)	Max. Allowed Load L (lbs.)
Single Piston Values						
16	27	0.59	35	3	5	30
25	66	0.55	132	9	27	65
32	108	1.10	318	36	120	115
40	169	1.42	575	53	156	195
50	265	1.50	1017	98	312	270
Double Piston Values						
16	27	0.59	81	6	9	60
25	66	0.55	336	18	45	130
32	108	1.10	720	72	600	230
40	169	1.42	1320	106	792	390
50	265	1.50	2304	196	1464	540

Rodless Pneumatic Cylinders
OSP-P Series
P1X Series
GDL Series
2002/P120 Series
P5S Electronic & Reed Sensors
Accessories
Part Number Index
Safety Guide, Offer of Sale



For inventory, lead times, and kit lookup, visit www.pdnplu.com

Piston Mountings - Ø 16mm

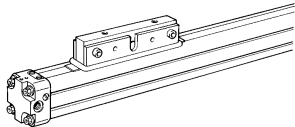
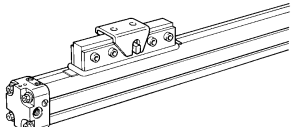
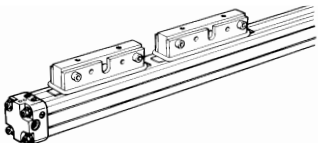
Design	Pictorial Representation	Description	Cyl. Ø	Weight 0" Stroke (lbs.)	Weight per inch (lbs.)
Type 2020/20		Piston Mounting NR20 Standard mounting. Mounted during cylinder assembly.	16	0.51	0.05
Type 2020/25		Piston Mounting NR25 Allows for a floating connection between the cylinder and an externally guided device.	16	0.55	0.05
Type 2220/20		Double Piston Mounting NR20 Two pistons in a single barrel using the standard NR20 mounting.	16	0.67	0.05

Rodless Pneumatic
Cylinders

OSP-P
Series

P1X
Series

GDL
Series

2002/P120
Series

P55 Electronic &
Reed Sensors

Accessories

Part Number
Index

Safety Guide,
Offer of Sale



For inventory, lead times, and kit
lookup, visit www.pdnplu.com

Overall Dimensions - Ø 16mm

Ø 16mm

Basic Dimensions (Single Piston)

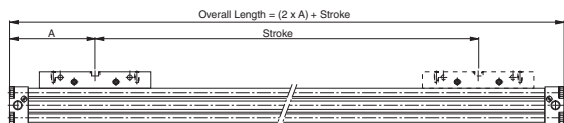

Basic Dimensions (Double Piston)

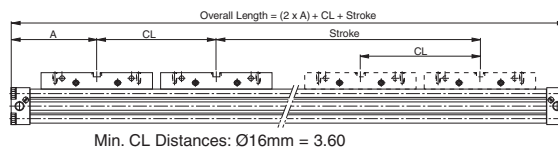

End Cap Dimensions Ø 16mm

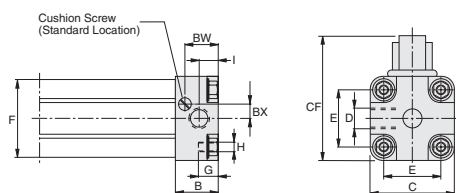

Piston Mounting NR20

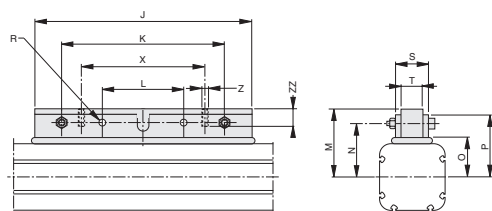

Piston Mounting NR25

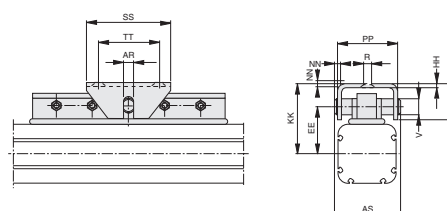

Cyl Ø	A	B	C	D	E	F	G	H	I	J	K	L	M	N	O	P	R	S	T	V	X	Z
16	2.56	.59	1.06	M5	.71	.94	.20	M3	.22	2.99	2.52	1.26	1.18	.94	.63	1.14	.18	.71	.39	.20	1.89	M4
Cyl Ø	AR	AS	BW	BX	CF	HH	KK	LL	MM	NN	PP	SS	TT	ZZ								
16	.12	1.10	.47	.16	1.71	.08	1.34	.96	.51	.06	.98	.79	.39	.31								

Rodless Pneumatic Cylinders
OSP-P Series
P1X Series
GDL Series
2002/P120 Series
P5S Electronic & Reed Sensors
Accessories
Part Number Index
Safety Guide, Offer of Sale



For inventory, lead times, and kit lookup, visit www.pdnplu.com

Piston Mountings - Ø 25mm, 32mm, 40mm, 50mm

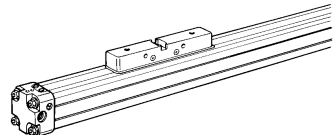
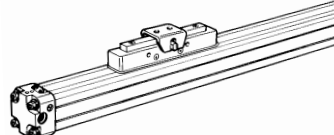
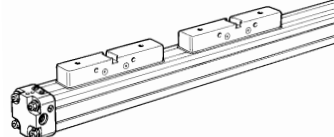
Design	Pictorial Representation	Description	Cyl. Ø	Weight 0" Stroke (lbs.)	Weight per inch (lbs.)
Type 2020/20		Piston Mounting NR20 Standard mounting. Mounted during cylinder assembly.	25	1.32	0.11
			32	3.19	0.20
			40	5.17	0.29
			50	7.70	0.43
Type 2020/25		Piston Mounting NR25 Allows for a floating connection between the cylinder and an externally guided device.	25	1.54	0.11
			32	3.85	0.20
			40	5.83	0.29
			50	9.46	0.43
Type 2220/20		Double Piston Mounting NR20 Two pistons in a single barrel using the standard NR20 mounting.	25	2.05	0.11
			32	5.15	0.20
			40	9.10	0.29
			50	13.20	0.43

Rodless Pneumatic Cylinders
OSP-P Series
P1X Series
GDL Series
2002/P120 Series
P55 Electronic & Reed Sensors
Accessories
Part Number Index
Safety Guide, Offer of Sale



For inventory, lead times, and kit lookup, visit www.pdnplu.com

Overall Dimensions - Ø 25mm, 32mm, 40mm, 50mm

Ø 25mm, 32mm, 40mm and 50mm

Basic Dimensions (Single Piston)

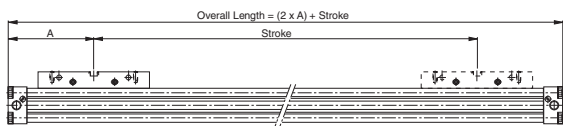

Basic Dimensions (Double Piston)

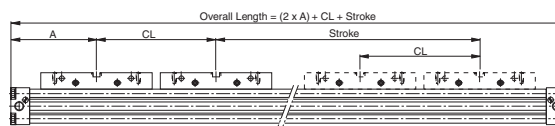

End Cap Dimensions

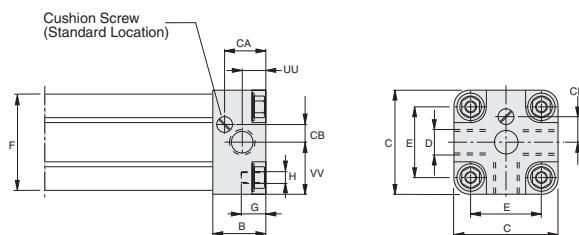

Piston Mounting NR20

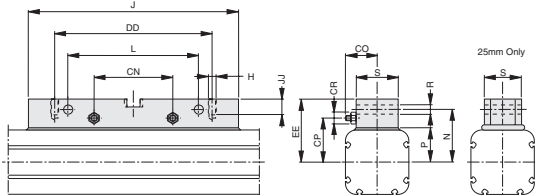

Piston Mounting NR25

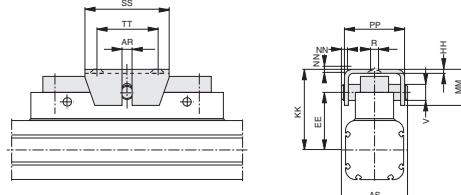

Cyl Ø	A	B	C	D	E	F	G	H	J	L	N	P	R	S	U	V	DD	EE
25	3.94	.91	1.57	1/8 NPT	1.06	1.42	.35	10-32	4.72	1.97	1.30	.75	.22	.91	.22	.31	3.15	1.50
32	4.92	1.06	2.09	1/4 NPT	1.42	1.93	.47	1/4-20	6.30	3.94	1.57	1.10	.26	1.26	.26	.47	4.72	1.89
40	5.91	1.06	2.48	1/4 NPT	1.81	2.32	.47	1/4-20	6.30	3.94	1.81	1.34	.26	1.26	.26	.47	4.72	2.13
50	6.70	1.26	3.07	3/8 NPT	2.13	2.83	.47	5/16-18	7.87	5.51	2.17	1.57	.35	1.34	.35	.63	6.30	2.56

Cyl Ø	HH	JJ	KK	LL	MM	NN	PP	SS	TT	UU	VV	AR	AS	BN	CA	CB	CD	CL (min.)
25	.12	.35	2.05	1.50	.79	±.10	1.46	1.26	.63	.33	.81	.20	1.65	2.05	.71	.26	.35	5.12
32	.16	.47	2.60	1.89	1.18	±.16	1.97	2.76	1.97	.41	1.04	.31	2.28	2.60	.83	.35	.51	6.90
40	.16	.47	2.83	2.13	1.18	±.16	1.97	2.76	1.97	.41	1.24	.31	2.28	2.83	.71	.51	.65	8.75
50	.20	.63	3.54	2.56	1.77	±.24	2.28	3.94	3.15	.49	1.54	.39	2.83	3.54	.83	.59	.73	10.00

Rodless Pneumatic Cylinders
 OSP-P Series
 P1X Series
 GDL Series
 2002/P120 Series
 P55 Electronic & Reed Sensors
 Accessories
 Part Number Index
 Safety Guide, Offer of Sale



For inventory, lead times, and kit lookup, visit www.pdnplu.com

Cylinder Mountings - Ø 16mm, 25mm, 32mm, 40mm, 50mm

Design	Pictorial Representation	Description	Cyl. Ø	Part Number	Weight (lbs.)
Type NR4		End Cap Mounting	16	2172-0101	0.02
			25	2172-0201	0.07
			32	2172-0351	0.11
			40	2172-0451	0.13
			50	2172-0551	0.26

End Cap Mounting NR4

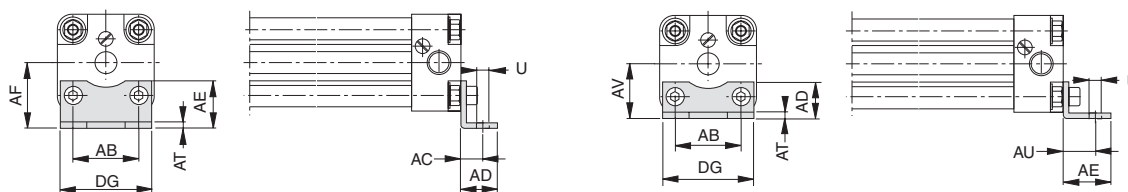

NR4 Mounting Bracket - Mtg. Style "A"

NR4 Mounting Bracket - Mtg. Style "B"

Cyl Ø	U	AB	AC	AD	AE	AF	AT	AU	AV	DG
16	.14	.71	.39	.55	.49	.59	.06	—	—	1.02
25	.22	1.06	.41	.71	.87	1.10	.08	.57	.94	1.54
32	.26	1.42	.47	.79	1.02	1.42	.12	.71	1.18	1.97
40	.26	1.81	.47	.79	1.02	1.61	.12	.71	1.38	2.36
50	.35	2.13	.71	1.10	1.34	2.01	.16	.94	1.77	2.91

- Rodless Pneumatic Cylinders
- OSP-P Series
- P1X Series
- GDL Series
- 2002/P120 Series
- P5S Electronic & Reed Sensors
- Accessories
- Part Number Index
- Safety Guide, Offer of Sale



For inventory, lead times, and kit lookup, visit www.pdnplu.com

Series 2002 - Joint Clamps

Bore sizes: 25mm, 32mm, 40mm and 50mm. Stroke lengths available up to 480"

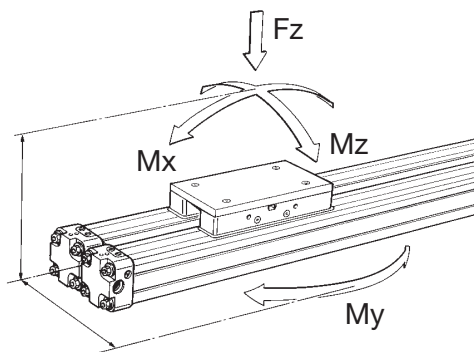

Loads, forces, moments

Cyl Ø (mm)	Theoretical Force at 87 PSI (lbs. force)	Cushion Length (in.)	Max. Allowed Bending Moment Mx (in./lbs.)	Max. Allowed Bending Moment Mz (in./lbs.)	Max. Allowed Bending Moment My (in./lbs.)	Max. Allowed Load L (lbs.)
Single Piston Values						
25	132	0.55	264	115	54	130
32	216	1.10	636	248	240	230
40	338	1.42	1150	444	312	390
50	530	1.50	2034	859	624	540
Double Piston Values						
25	132	0.55	672	230	90	260
32	216	1.10	1440	496	1200	460
40	338	1.42	2640	888	1584	780
50	530	1.50	4608	1718	2928	1080

- Rodless Pneumatic Cylinders
- OSP-P Series
- P1X Series
- GDL Series
- 2002/P120 Series
- P5S Electronic & Reed Sensors
- Accessories
- Part Number Index
- Safety Guide, Offer of Sale



For inventory, lead times, and kit lookup, visit www.pdnplu.com

Piston Mountings - Ø 25mm, 32mm, 40mm, 50mm

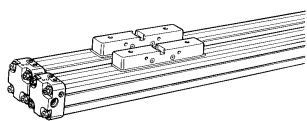
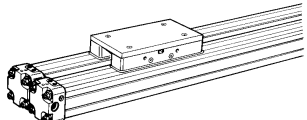
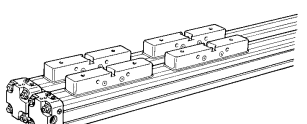
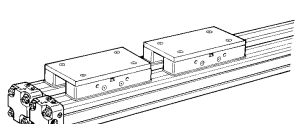
Designation	Pictorial Representation	Description	Cyl. Ø	Weight 0" Stroke (lbs.)	Weight per inch (lbs.)
Type J2020/20		Piston Mounting NR20 Standard mounting. Mounted during cylinder assembly.	25	2.82	0.24
			32	6.84	0.46
			40	10.92	0.63
			50	16.50	0.97
Type J2020/24		Piston Mounting NR24 Flat, platform mounting. Provides a common connection across both pistons.	25	3.24	0.24
			32	7.72	0.46
			40	11.91	0.63
			50	18.70	0.97
Type J2220/20		Piston Mounting NR20 Two pistons in each barrel using the standard NR20 mounting.	25	4.44	0.24
			32	11.11	0.46
			40	19.37	0.63
			50	28.60	0.97
Type J2220/24		Piston Mounting NR24 Two pistons in each barrel. Provides a common connection across each set of pistons.	25	5.28	0.24
			32	12.87	0.46
			40	21.35	0.63
			50	33.00	0.97

Rodless Pneumatic
Cylinders

OSP-P
Series

P1X
Series

GDL
Series

2002/P120
Series

P55 Electronic &
Reed Sensors

Accessories

Part Number
Index

Safety Guide,
Offer of Sale



For inventory, lead times, and kit
lookup, visit www.pdnplu.com

Overall Dimensions - Ø 25mm, 32mm, 40mm, 50mm

Basic Dimensions (Single Piston)

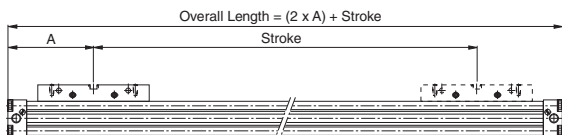

Basic Dimensions (Double Piston)

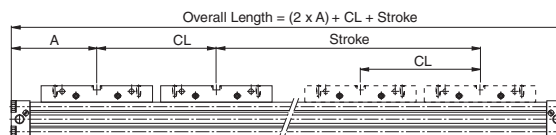

End Cap Cross Section

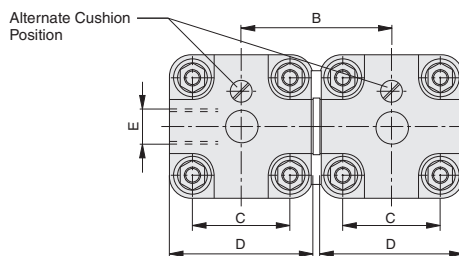

Piston Mounting NR24

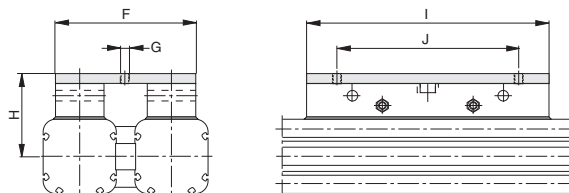

Cyl Ø	A	B	C	D	E	F	G	H	I	J	CL (min.)
25	3.94	1.73	1.06	1.57	1/8 NPT	2.76	1/4-20	1.81	4.72	3.15	5.12
32	4.92	2.20	1.42	2.09	1/4 NPT	3.54	5/16-18	2.28	6.30	4.73	6.90
40	5.91	2.60	1.81	2.48	1/4 NPT	3.94	5/16-18	2.52	6.30	4.73	8.75
50	6.70	3.19	2.13	3.07	3/8 NPT	4.73	3/8-16	3.15	7.88	6.30	10.00

Rodless Pneumatic Cylinders
OSP-P Series
P1X Series
GDL Series
2002/P120 Series
P55 Electronic & Reed Sensors
Accessories
Part Number Index
Safety Guide, Offer of Sale



For inventory, lead times, and kit lookup, visit www.pdnplu.com

Cylinder Mountings - Ø 25mm, 32mm, 40mm, 50mm

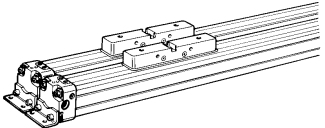
Design	Pictorial Representation	Description	Cyl. Ø	Part Number	Weight (lbs.)
Type NR4		End Cap Mounting	25	2172-0201	0.07
		Provides rigid end mounting of the cylinder.	32	2172-0351	0.11
			40	2172-0451	0.13
			50	2172-0551	0.26

Orientation Examples

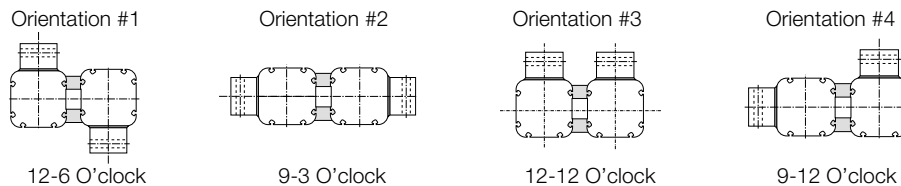

Note: Joint Clamp cylinder loadings will vary depending on the above orientation used. Consult the factory for design assistance.

Rodless Pneumatic Cylinders

OSP-P Series

P1X Series

GDL Series

2002/P120 Series

P55 Electronic & Reed Sensors

Accessories

Part Number Index

Safety Guide, Offer of Sale



For inventory, lead times, and kit lookup, visit www.pdnplu.com

P120 Summary

P120-S/20

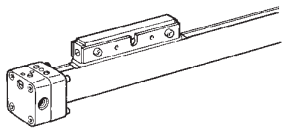

P120-S/22

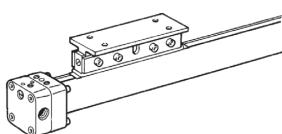

P120-S/25

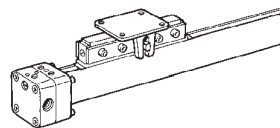

P120-L/26

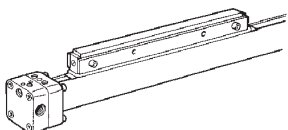

P120-L/28

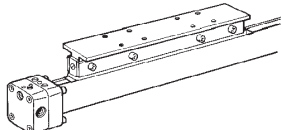

Rodless Pneumatic
Cylinders

OSP-P
Series

P1X
Series

GDL
Series

2002/P120
Series

P55 Electronic &
Reed Sensors

Accessories

Part Number
Index

Safety Guide,
Offer of Sale

**Cushion Diagram
 Series 2002**

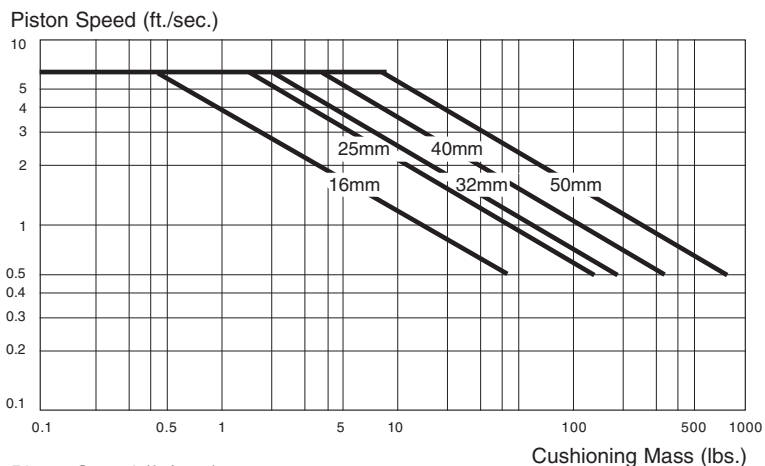

**Cushion Diagram
 Series P120**

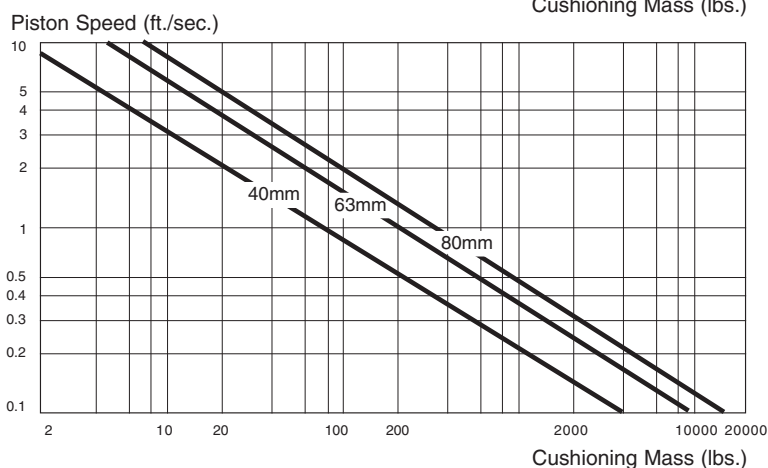

For inventory, lead times, and kit lookup, visit www.pdnplu.com

Rodless Pneumatic Cylinders
OSP-P Series
P1X Series
GDL Series
2002/P120 Series
P5S Electronic & Reed Sensors
Accessories
Part Number Index
Safety Guide, Offer of Sale

Series P120 - Basic Design

Bore sizes: 40mm, 63mm and 80mm. Stroke lengths available up to 480"

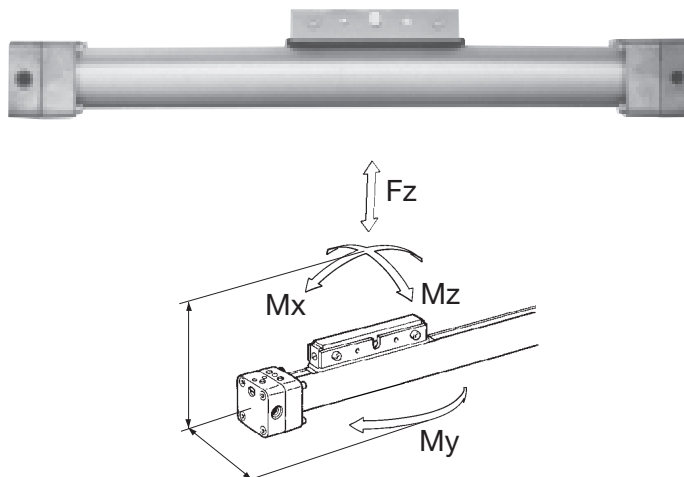

Loads, forces, moments

Cyl Ø (mm)	Theoretical Force at 87 PSI (lbs. force)	Cushion Length (in.)	Max. Allowed Bending Moment Mx (in./lbs.)	Max. Allowed Bending Moment Mz (in./lbs.)	Max. Allowed Bending Moment My (in./lbs.)	Max. Allowed Load L (lbs.)
Single Piston Values						
40	169	1.26	528	36	72	170
63	420	1.57	1776	72	216	370
80	677	1.73	3192	144	420	590
Double Piston Values						
40	169	1.26	1200	72	216	170
63	420	1.57	3984	144	660	370
80	677	1.73	6372	288	1236	590



For inventory, lead times, and kit lookup, visit www.pdnplu.com

Series P120 - Ø 40mm, 63mm, 80mm

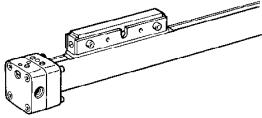
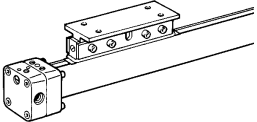
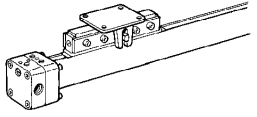
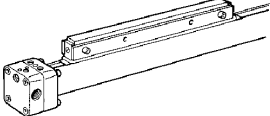
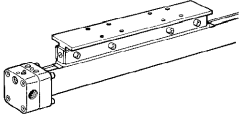
Designation	Pictorial Representation	Description	Cyl. Ø	Weight 0" Stroke (lbs.)	Weight per inch (lbs.)
Type P120-S/20		Piston Mounting S/20	40	7.26	0.20
		Standard mounting. Mounted during cylinder assembly.	63	20.46	0.45
			80	35.42	0.71
Type P120-S/22		Piston Mounting S/22	40	7.48	0.20
		Flat, platform mounting	63	20.90	0.45
			80	36.74	0.71
Type P120-S/25		Piston Mounting S/25	40	7.92	0.20
		Allows for a floating connection between the cylinder and an externally guided device.	63	22.66	0.45
			80	38.06	0.71
Type P120-L/26		Piston Mounting L/26	40	11.00	0.20
		Standard mounting. Mounted during cylinder assembly.	63	30.58	0.45
			80	51.04	0.71
Type P120-L/28		Piston Mounting L/28	40	11.44	0.20
		Flat, platform mounting.	63	32.12	0.45
			80	53.68	0.71

Rodless Pneumatic Cylinders
OSP-P Series
P1X Series
GDL Series
2002/P120 Series
P55 Electronic & Reed Sensors
Accessories
Part Number Index
Safety Guide, Offer of Sale



For inventory, lead times, and kit lookup, visit www.pdnplu.com

Overall Dimensions - Ø 40mm, 63mm, 80mm

Basic Dimensions

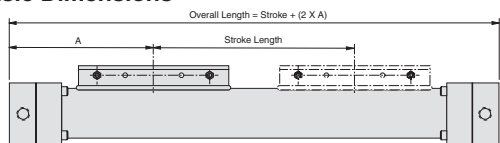

End Cap Dimensions

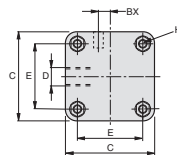

Piston Mounting S/20

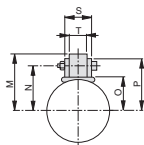
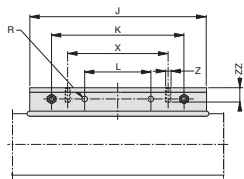

Piston Mounting L/26

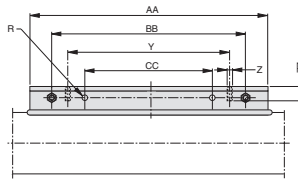

Piston Mounting S/22

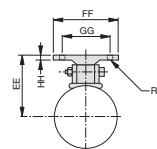
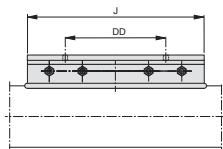

Piston Mounting L/28

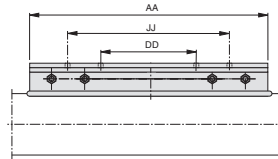

Piston Mounting S/25

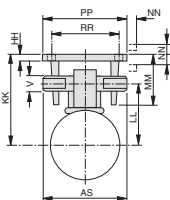
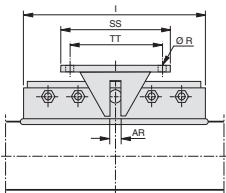

Cyl Ø	A (S)	A (L)	C	D	E	H	J	K	L	M	N	O	P	R	S
40	5.91	9.91	2.83	1/4 NPT	2.13	1/4-20	5.91	4.33	2.17	2.40	1.93	1.28	2.24	.28	1.10
63	8.46	14.46	4.17	3/8 NPT	3.07	5/16-18	8.66	7.09	3.54	3.27	2.68	1.89	3.07	.35	1.18
80	10.24	16.24	5.20	1/2 NPT	3.78	3/8-16	11.02	9.45	4.72	3.98	3.27	2.36	3.74	.43	1.26

Cyl Ø	T	V	X	Y	Z	AA	AR	AS	BB	BX	CC	DD	EE	FF	GG
40	.71	.47	90	7.09	M6	11.81	.31	3.31	9.45	.43	4.72	3.15	2.60	2.36	1.77
63	.75	.63	140	11.81	M8	18.90	.39	3.54	15.75	.59	7.87	5.12	3.50	3.15	2.36
80	.79	.79	190	14.17	M10	22.05	.51	4.33	18.90	.63	9.45	7.09	4.25	3.94	2.95

Cyl Ø	HH	JJ	KK	LL	MM	NN	PP	RR	SS	TT	ZZ	α
40	.24	6.30	2.95	2.00	1.26	±.32	2.76	2.17	3.54	2.95	.47	22°
63	.28	10.24	3.94	2.76	1.54	±.39	3.54	2.76	4.72	3.94	.63	15°
80	.31	14.17	4.80	3.39	1.89	±.47	4.33	3.35	5.91	4.92	.79	15°



For inventory, lead times, and kit lookup, visit www.pdnplu.com

Cylinder Mountings - Ø 40mm, 63mm, 80mm

Design	Pictorial Representation	Description	Cyl. Ø	Part Number	Weight (lbs.)
Type NR3		End Cap Lug Mount	40	2170-0451	0.22
			63	2170-0651	0.66
			80	2170-0851	1.32

End Cap Lug Mount NR3

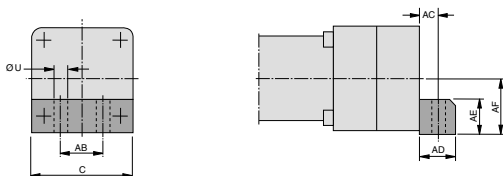

Cyl Ø	C	U	AB	AC	AD	AE	AF
40	2.83	.35	1.18	.49	.94	.94	1.50
63	4.17	.43	1.89	.59	1.18	1.57	2.24
80	5.20	.55	2.36	.69	1.38	1.97	2.83

Position of Cylinder Mounting

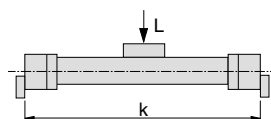
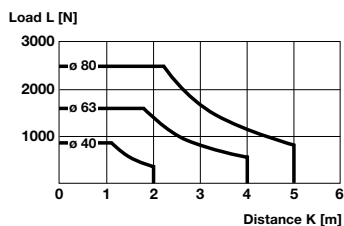

Rodless Pneumatic Cylinders
OSP-P Series
P1X Series
GDL Series
2002/P120 Series
P55 Electronic & Reed Sensors
Accessories
Part Number Index
Safety Guide, Offer of Sale



For inventory, lead times, and kit lookup, visit www.pdnplu.com

Rodless Pneumatic Cylinders
OSP-P Series
P1X Series
GDL Series
2002/P120 Series
P5S Electronic & Reed Sensors
Accessories
Part Number Index
Safety Guide, Offer of Sale

Type RS

In the type RS contact is made by a mechanical **reed switch** encapsulated in glass.

Direct connection with 2-pole cable, 5 m long, open ended (**Type RS-K**).

Type ES

In the type ES contact is made by an **electronic switch** – without bounce or wear and protected from pole reversal. The output is short circuit proof and insensitive to shocks and vibrations. Connection is by 3-pole connector for easy disconnection.

Fitted with connection cable 100 mm long with connector.

A 5 m cable with connector and open end can be ordered separately, or use the Order No. for the complete Type ES with 5 m cable.

Magnetic Switches RS and ES

Electrical Service Life Protective Measures

Magnetic switches are sensitive to excessive currents and inductions. With high switching frequencies and inductive loads such as relays, solenoid valves or lifting magnets, service life will be greatly reduced.

With **resistive and capacitive loads** with high switch-on current, such as light bulbs, a protective resistor should be fitted. This also applies to long cable lengths and voltages over 100 V.

In the switching of inductive loads such as relays, solenoid valves and lifting magnets, voltage peaks (transients) are generated which must be suppressed by protective diodes, RC loops or varistors.

Connection Examples

- Load with protective circuits
- (a) Protective resistor for light bulb
- (b) Freewheel diode on inductivity
- (c) Varistor on inductivity
- (d) RC element on inductivity

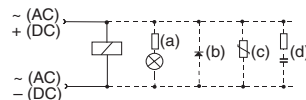

For the type ES, external protective circuits are not normally needed.

Electrical Connection

Type RS

Normally closed (NC)

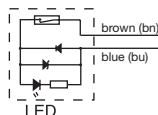

Normally open (NO)

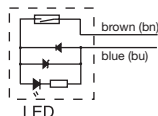

Type ES

Standard Version:
Type PNP

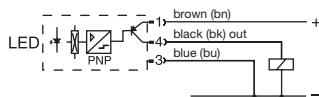

Optional Version
Type NPN

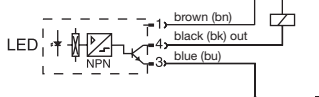

Dimensions (mm) * Length with possible minus tolerance, see chart below

Type RS-K

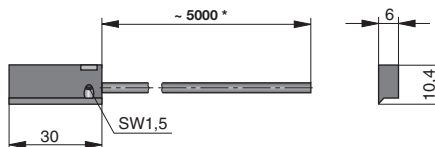

Type ES-S

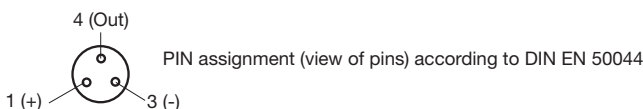
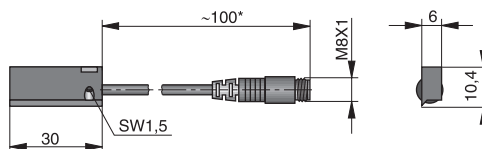

Length of connection cable with length tolerance

Magnetic Switch Order No.	Type	Nominal cable length	Length tolerance
KL3045	RS-K Normally Open	5000 mm	-50 mm
KL3048	RS-K Normally Closed	100 mm	-20 mm
10750	ES-S PNP	5000 mm	-50 mm
10751	ES-S NPN	145 mm	±5 mm



For inventory, lead times, and kit lookup, visit www.pdnplu.com

Type RST

In the type RST contact is made by a mechanical **reed switch** encapsulated in glass.

Type EST

In the type EST contact is made by an **electronic switch** – without bounce or wear and protected from pole reversal. The output is short circuit proof and insensitive to shocks and vibrations. Connection is by 3-pole connector for easy disconnection.

Fitted with connection cable 100 mm long with connector.

A 5 m cable with connector and open end can be ordered separately, or use the Order No. for the complete Type ES with 5 m cable.

Magnetic Switches RST and EST

Electrical Service Life Protective Measures

Magnetic switches are sensitive to excessive currents and inductions. With high switching frequencies and inductive loads such as relays, solenoid valves or lifting magnets, service life will be greatly reduced.

With **resistive and capacitive loads** with high switch-on current, such as light bulbs, a protective resistor should be fitted. This also applies to long cable lengths and voltages over 100 V.

In the switching of inductive loads such as relays, solenoid valves and lifting magnets, voltage peaks (transients) are generated which must be suppressed by protective diodes, RC loops or varistors.

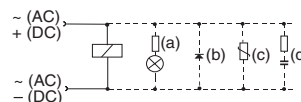

Electrical Connection

Type RST-K

Normally closed (NC)

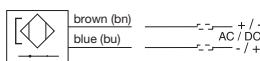

Normally open (NO)

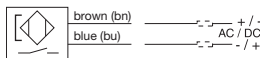

Type RST-S

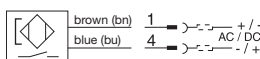

Type EST-K



Type EST-S

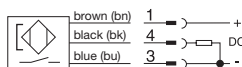

Ordering Information

Type	Voltage	Order No.
RST-K	10-30V AC/DC	KL3300
EST-S	10-30V DC	KL3312

Rodless Pneumatic Cylinders
OSP-P Series
P1X Series
GDL Series
2002/P120 Series
P55 Electronic & Reed Sensors
Accessories
Part Number Index
Safety Guide, Offer of Sale



For inventory, lead times, and kit lookup, visit www.pdnplu.com

Rodless Pneumatic Cylinders
OSP-P Series
P1X Series
GDL Series
2002/P120 Series
P5S Electronic & Reed Sensors
Accessories
Part Number Index
Safety Guide, Offer of Sale

Dimensions (mm)

Type RST-K, EST-K

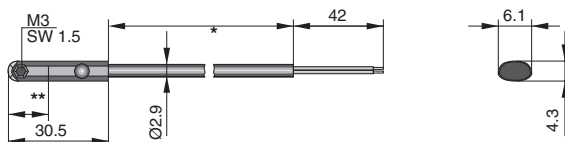

- * Cable lengths available: 5000 mm ± 75 mm
2000 mm ± 40 mm
- ** Switching point: Type RST-K Normally closed 14 mm
Type RST-K Normally open 12.3 mm
Type EST-K Normally open 8.1 mm

Type RST-S, EST-S

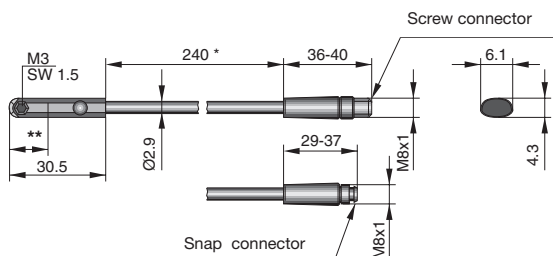

- * ± 6 mm
- ** Switching point: Type RST-K Normally closed 14 mm
Type RST-K Normally open 12.3 mm
Type EST-K Normally open 8.1 mm

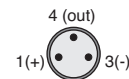

PIN assignment
 (view of pins)
 to DIN EN 50044

Adapter for Magnetic Switch, KL9510

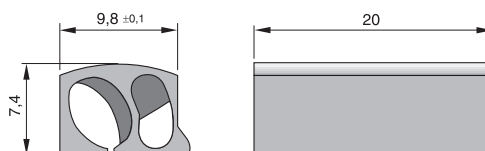

Installation

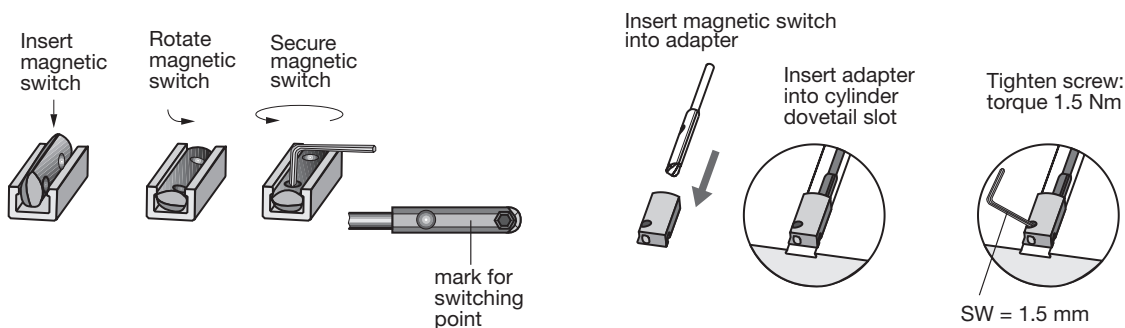

For inventory, lead times, and kit lookup, visit www.pdnplu.com

Spare Parts

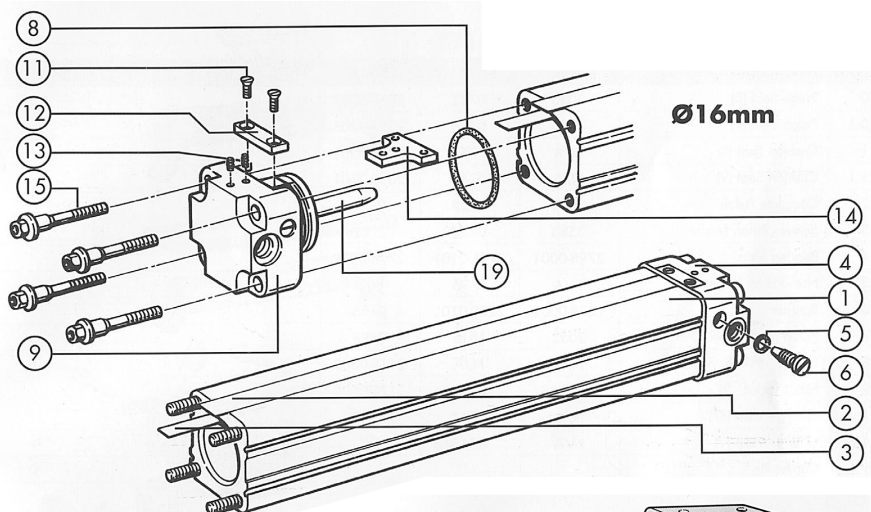

2002 Basic Cylinder, Ø16mm

Item	Description	16mm
1	Cylinder Barrel	2152-0101+S
2***	Outer Band	2080-0101+S
3***	Inner Band	2192+0101+S
4	End Cap - Right (B)	2164-0154
4.1	End Cap - Right (F)	2714-0154
5	O-Ring - Cushion Screw (B)	0766
5.1	O-Ring - Cushion Screw (F)	0767
6	Cushion Screw	0734
7	N/A	
8	O-Ring - Cushion Pipe (B)	0732
8.1	O-Ring - Cushion Pipe (F)	0733
9	End Cap - Left (B)	2164-0153
9.1	End Cap - Left (F)	2714-0153
10	O-ring Gasket End Cap (B)	N/A
10.1	O-ring Gasket End Cap (F)	N/A
11	Screw - Outer Band Lock	0847
12	Outer Band Lock	0738
13	Screw - Inner Band Lock	0846
14	Inner Band Lock	0736
15	End Cap Screw	0735
19	Cushion Pipe	N/A
**	Service Pack-1 Piston (B)	SP16-B-1 xS
**	Service Pack-1 (F)	SP16-V-1 xS
**	Service Pack-2 (B)	SP16-B-2 xS
**	Service Pack-2 (F)	SP16-V-2 xS
	Seal Kit-1 (B)	2790-0101
	Seal Kit-1 (F)	2791-0101
	Seal Kit-2 (B)	2790-0101-2
	Seal Kit-2 (F)	2791-0101-2

(B) = Buna-N
(F) = Fluorocarbon

** Note: Please identify stroke "S" required when ordering.

*** Note: These items can only be purchased in a service pack.

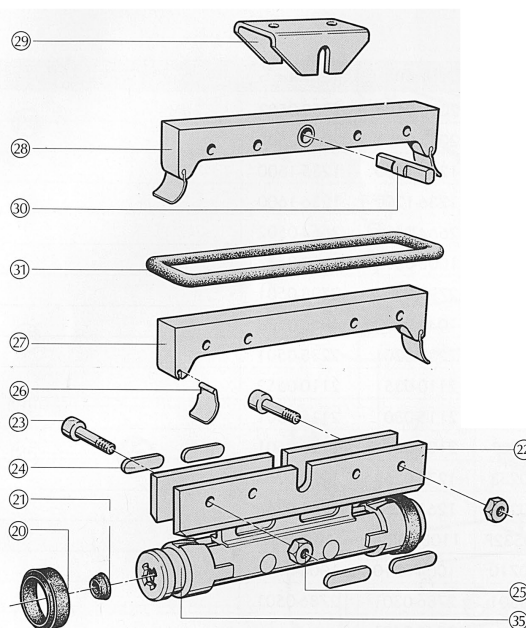

Item	Description	16mm
20	Piston Seal (B)	0745
20.1	Piston Seal (F)	0746
21	Cushion Seal (B)	0751
21.1*	Cushion Seal (F)	0752
22	Complete Piston	1853
23	Screw - Piston Mount	0754
24	Bearing Strip	2798-0101
25	Nut - Piston Mount	0796
26	Scraper	2238-0101
27	Piston Mount - NR20	1815
28	Bracket - NR25 Mount	N/A
29	Fork Bracket	0758
31	O-ring - Yoke (B)	0747
31.1	O-ring - Yoke (F)	0748

Rodless Pneumatic Cylinders
OSP-P Series
P1X Series
GDL Series
2002/P120 Series
P5S Electronic & Reed Sensors
Accessories
Part Number Index
Safety Guide, Offer of Sale



For inventory, lead times, and kit lookup, visit www.pdnplu.com

Spare Parts

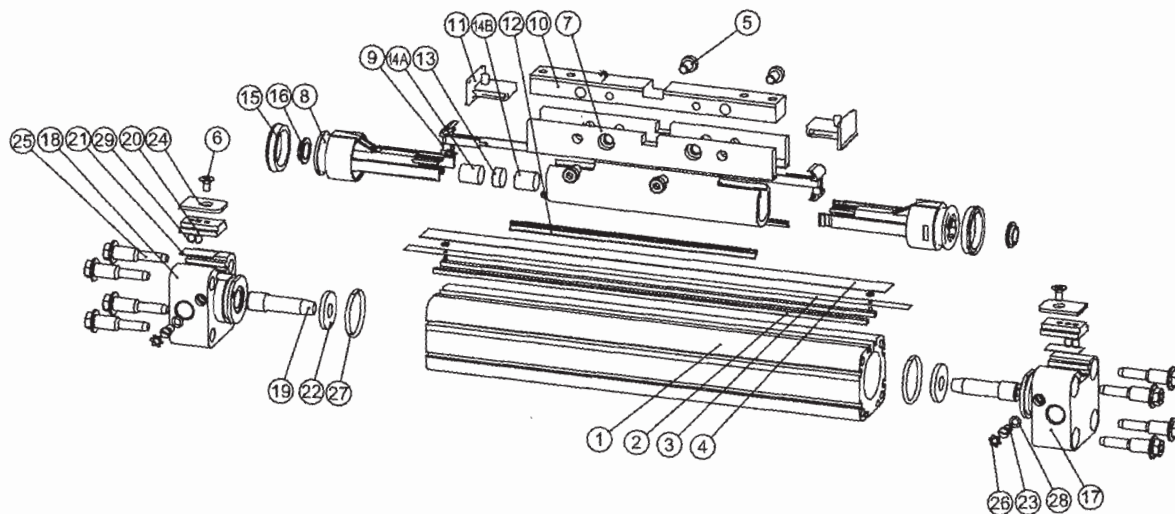

NOTE: FOR 25mm ONLY, ITEMS 23, 26 & 28 ARE AN INTEGRAL PART OF THE CAP (ITEMS 17 & 18)

2002 Basic Cylinder, Ø25mm - Ø50mm

Item	Description	Kit to Purchase
1	Barrel	Purchase Separate
2	Magnet Strip	Purchase Separate
3	Inner Band	Service Pack
4	Outer Band	Service Pack
5	Piston Mount Screw	Piston Mount Kit
6	Outer Bandlock Screw	End Cap Assembly
7	Piston	Piston Assembly Kit
8	Support Ring (White, Red, Green)	Piston Assembly Kit
9	Slide Shoe (Yellow, Tan, Black)	Seal Kit
10	Piston Mounting	Piston Mount Kit
11	Scraper	Seal Kit
12	Slide Wiper	Seal Kit
13	Magnet	Piston Assembly Kit
14A	Magnet Holder (Aluminum)	Piston Assembly Kit
14B	Magnet Holder (Steel)	Piston Assembly Kit
15	Piston Seal	Seal Kit
16	Cushion Seal	Seal Kit
17	End Cap - Left Hand	End Cap Assembly
18	End Cap - Right Hand	End Cap Assembly
19	Cushion Pipe	End Cap Assembly

Item	Description	Kit to Purchase
20	Inner Band Lock	End Cap Assembly
21	Shim Piece	End Cap Assembly
22	Cushion Disc	Seal Kit
23	Cushion Adjustment Screw	End Cap Assembly
24	Outer Band Lock	End Cap Assembly
25	End Cap Screw	End Cap Assembly
26	Locking Ring	Purchase Separate
27	O-ring End Cap	Seal Kit
28	O-Ring - Cushion Screw	Seal Kit
29	Screw - Inner Band Lock	End Cap Assembly

* See page 159 for ordering instructions on kit part numbers.



For inventory, lead times, and kit lookup, visit www.pdnplu.com

Kit Parts

Size	Part Number			
	25mm	32mm	40mm	50mm
Barrel	2152-0201 +S	2152-0301 +S	2152-0404 +S	2152-0502 +S
Magnetic Strip	2244-0201 +S	2244-0301 +S	2244-0451 +S	2244-0501 +S

Piston Assembly Kits – includes seals, bearings, support rings, magnets and holders

(Buna)	2002-25-PISTON-B	2002-32-PISTON-B	2002-40-PISTON-B	2002-50-PISTON-B
(FKM)	2002-25-PISTON-V	2002-32-PISTON-V	2002-40-PISTON-V	2002-50-PISTON-V

End Cap Assembly Kits – includes end cap set with cushion pipes, o-rings, cap screws, cushion discs, and hand locks

US Threads (Buna)	2002-25-END-CAP-B	2002-32-END-CAP-B	2002-40-END-CAP-B	2002-50-END-CAP-B
US Threads (FKM)	2002-25-END-CAP-V	2002-32-END-CAP-V	2002-40-END-CAP-V	2002-50-END-CAP-V
Metric Threads (Buna)	2002-25-END-CAP-MO	2002-32-END-CAP-MO	2002-40-END-CAP-MO	2002-50-END-CAP-MO
Metric Threads (FKM)	2002-25-END-CAP-V-MO	2002-32-END-CAP-V-MO	2002-40-END-CAP-V-MO	2002-50-END-CAP-V-MO

Piston Assembly Kits – includes piston mount, scrapers and screws

US Threads	2002-25-PISTON-MT	2002-32-PISTON-MT	2002-40-PISTON-MT	2002-50-PISTON-MT
------------	-------------------	-------------------	-------------------	-------------------

Rodless Pneumatic Cylinders
OSP-P Series
P1X Series
GDL Series
2002/P120 Series
P5S Electronic & Reed Sensors
Accessories
Part Number Index
Safety Guide, Offer of Sale



For inventory, lead times, and kit lookup, visit www.pdnplu.com

Spare Parts

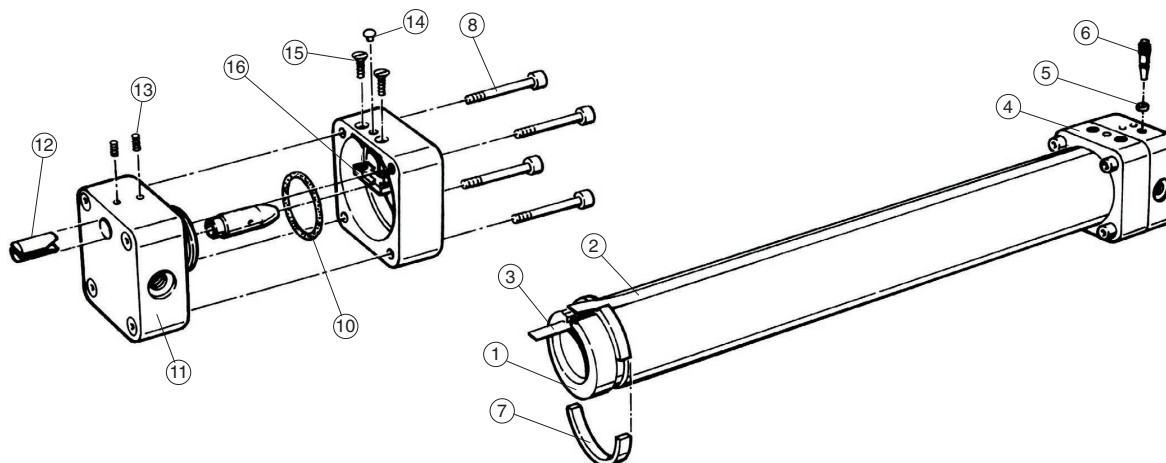

P120 Basic Cylinder, Ø40mm - Ø80mm

Item	Description	40mm	63mm	80mm
1	Cylinder Barrel S/	2152-0403+S	2152-0602+S	2152-0801+S
1.1	Cylinder Barrel L/	2153-0452+S	2153-0651+S	2153-0851+S
1.2	Magnet Strip	2244+0401+S	2244-0601+S	2074-0801
2***	Outer Band S/	2080-0403+S	2080-0603+S	2080-0801+S
2.1***	Outer Band L/	2081-0451+S	2081-0651+S	2081-0851+S
3***	Inner Band S/	2192-0402+S	2192-0602+S	2192-0802+S
3.1***	Inner Band L/	2193-0451+S	2193-0652+S	2193-0851+S
4	End Cap - Right (B)	2164-0454-R	2164-0654-R	2164-0852-R
4.1	End Cap - Right (F)	2714-0452-R	2714-0652-R	2714-0851-R
5	O-Ring - Cushion Screw (B)	1252-0101	1252-0101	1252-0101
5.1	O-Ring - Cushion Screw (F)	1262-0101	1262-0101	1262-0101
6	Cushion Screw	1213	1257	1257
7	Lock Ring - Upper/Lower	1207	1254	1263
8	Screw - End Cap	1004-0718	1004-0920	1004-1124
9	Cap Ring	2887	2889	1262
10	O-Ring - End Cap (B)	1250-0307	1250-0503	1250-0506
10.1	O-Ring - End Cap (F)	1261-0307	1261-0503	1261-0506
11	End Cap - Left (B)	2164-0454-L	2164-0654-L	2164-0852-L
11.1	End Cap - Left (F)	2714-0452-L	2714-0652-L	2714-0851-L
12	Inner Band Lock Set	4833	6833	8833
13	Screw - Inner Band Lock	1024-0605	1024-0605	1024-0807
14	Plug - Cap Ring	2847	2847	2847
15	Screw - Outer Band Lock	1033-0505	1033-0506	1033-0506
16	Outer Band Lock	1204	1204	1204
**	Service Pack-Short Piston (B)	SP124-B-S xS	SP126-B-S xS	SP128-B-S xS
**	Service Pack-Short Piston (F)	SP124-V-S xS	SP126-V-S xS	SP128-V-S xS
**	Service Pack-Long Piston (B)	SP124-B-L xS	SP126-B-L xS	SP128-B-L xS
**	Service Pack-Long Piston (F)	SP124-V-L xS	SP126-V-L xS	SP128-V-L xS
	Seal Kit-Short Piston (B)	2790-0401	2790-0601	2790-0801
	Seal Kit-Short Piston (F)	2791-0401	2791-0601	2791-0801
	Seal Kit-Long Piston (B)	2792-0401	2792-0601	2792-0801
	Seal Kit-Long Piston (F)	2793-0401	2793-0601	2793-0801

(B) = Buna-N
(F) = Fluorocarbon
** Note: Please identify stroke "S" required when ordering.
*** Note: These items can only be purchased in a service pack.



For inventory, lead times, and kit lookup, visit www.pdnplu.com

Spare Parts

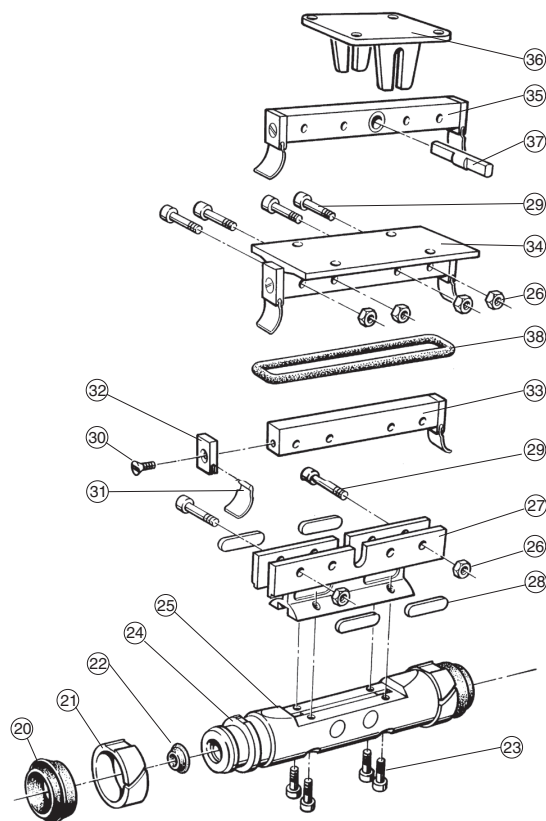

P120 - Short Piston, Ø40mm - Ø80mm

Item	Description	40mm	63mm	80mm
20	Piston Seal (B)	1275	1345	1375
20.1	Piston Seal (F)	1276	1346	1376
21	Bearing Ring	1274	1344	1374
22	Cushion Seal (B)	1277	1347	1377
22.1	Cushion Seal (F)	1278	1348	1378
23	Screw - Yoke	1000-0612	1000-0816	1000-0818
24	Piston Axle (non-magnetic) S/	4843	6843	8843
24.1	Piston Axle (magnet 1 side) S/	N/A	6843	8843
25	Piston Axle (magnet 2 side) S/	4843	6843	8843
26	Nut - Piston Mount	1040-0600	1040-0800	1040-1000
27	Piston Yoke	1287	1356	1406
28	Bearing Strip	2798-0401	2798-0601	2798-0801
29	Screw - Piston Mount	1283	1000-0816	1000-1018
30	Screw - Piston Mount End	1038-0507	1038-0507	1038-0507
31	Scraper	1279	1349	1379
32	Piston Mount End Plate	1286	2040-0604	2040-0801
33	Piston Mount - S/20	1817	2503	2504
34	Piston Mount - S/22	2505	2507	2508
35	Piston Mount - S/25	2186-0404	2186-0604	2186-0802
36	Fork Bracket	1947	1955	1963
37	Carrier Pin	1948	1956	1964
38	O-Ring - Yoke (B)	1281	1351	1401
38.1	O-Ring - Yoke (F)	1282	1352	1402

(B) = Buna-N
 (F) = Fluorocarbon

Rodless Pneumatic Cylinders
OSP-P Series
P1X Series
GDL Series
2002/P120 Series
P55 Electronic & Reed Sensors
Accessories
Part Number Index
Safety Guide, Offer of Sale



For inventory, lead times, and kit lookup, visit www.pdnplu.com

Spare Parts

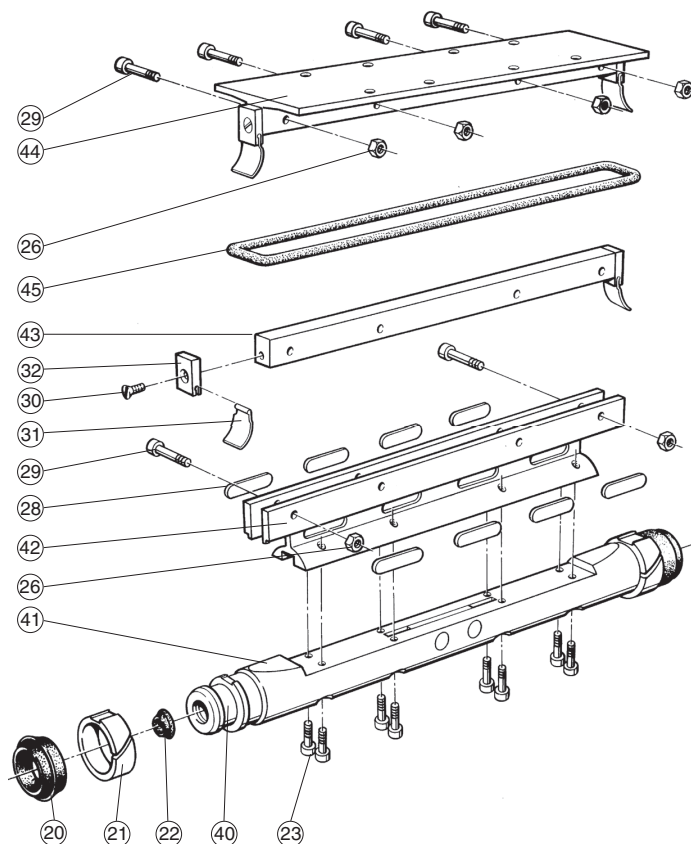

P120 - Long Piston, Ø40mm - Ø80mm

Item	Description	40mm	63mm	80mm
20	Piston Seal (B)	1275	1345	1375
20.1	Piston Seal (F)	1276	1346	1376
21	Bearing Ring	1274	1344	1374
22	Cushion Seal (B)	1277	1347	1377
22.1	Cushion Seal (F)	1278	1349	1378
23	Screw - Yoke	1000-0612	1000-0816	1000-0818
26	Nut - Piston Mount	1040-0600	1040-0800	1040-1000
28	Bearing Strip	2798-0401	2798-0601	2798-0801
29	Screw - Piston Mount	1283	1000-0816	1000-1018
30	Screw - Piston Mount End	1038-0507	1038-0507	1038-0507
31	Scraper	1279	1349	1379
32	Piston Mount End	1286	2040-0604	2040-0801
40	Piston Axle (non-magnetic) L/	4844	6844	8844
40.1	Piston Axle (magnet 1 side) L/	N/A	6844	8844
41	Piston Axle (magnet 2 side) L/	4844	6844	8844
42	Piston Yoke	1298	1367	1417
43	Piston Mount - L/26	2492	2494	2495
44	Piston Mount - L/28	2496	2498	2499
45	O-Ring - Yoke (B)	1272-0526	1365	1272-0542
45.1	O-Ring - Yoke (F)	1297	1262-0538	1416

(B) = Buna-N
 (F) = Fluorocarbon



For inventory, lead times, and kit lookup, visit www.pdnplu.com

Kit Parts

Service Packs - Series 2002 / Series P120 - All bore sizes.

Series 2002	Bore Sizes				
	16mm	25mm	32mm	40mm	50mm
Buna-N Service Pack Single Piston	SP16-B-1	SP25R-B-1	SP32R-B-1	SP40R-B-1	SP50R-B-1
FKM Service Pack Single Piston	SP16-V-1	SP25R-V-1	SP32R-V-1	SP40R-V-1	SP50R-V-1
Buna-N Service Pack Double Piston	SP16-B-2	SP25R-B-2	SP32R-B-2	SP40R-B-2	SP50R-B-2
FKM Service Pack Double Piston	SP16-V-2	SP25R-V-2	SP32R-V-2	SP40R-V-2	SP50R-V-2

Series P120	Bore Sizes		
	40mm	60mm	80mm
Buna-N Service Pack Short Piston	SP124-B-S	SP126-B-S	SP128-B-S
FKM Service Pack Short Piston	SP124-V-S	SP126-V-S	SP128-V-S
Buna-N Service Pack Long Piston	SP124-B-L	SP126-B-L	SP128-B-L
FKM Service Pack Long Piston	SP124-V-L	SP126-V-L	SP128-V-L

Note: All Service Packs contain complete seal kits, inner and outer bands, cleaning tool, grease and repair instructions.

Upgrade Kit - required for cylinders manufactured prior to January 1, 2002

Series 2002	Bore Sizes			
	25mm	32mm	40mm	50mm
Buna-N Upgrade Kit Single Piston	25-UPGRADE-S-B	32-UPGRADE-S-B	40-UPGRADE-S-B	50-UPGRADE-S-B
FKM Upgrade Kit Single Piston	25-UPGRADE-S-V	32-UPGRADE-S-V	40-UPGRADE-S-V	50-UPGRADE-S-V
Buna-N Upgrade Kit Double Piston	25-UPGRADE-S-B-2	32-UPGRADE-S-B-2	40-UPGRADE-S-B-2	50-UPGRADE-S-B-2
FKM Upgrade Kit Double Piston	25-UPGRADE-S-V-2	32-UPGRADE-S-V-2	40-UPGRADE-S-V-2	50-UPGRADE-S-V-2

Note: Upgrade kits include piston assembly, end cap assembly, piston mount assembly and complete service pack.
 *S = Stroke

Rodless Pneumatic Cylinders
OSP-P Series
P1X Series
GDL Series
2002/P120 Series
P55 Electronic & Reed Sensors
Accessories
Part Number Index
Safety Guide, Offer of Sale



For inventory, lead times, and kit lookup, visit www.pdnplu.com

Rodless Pneumatic Cylinders	OSP-P Series	P1X Series	GDL Series	2002/P120 Series	P55 Electronic & Reed Sensors	Accessories	Part Number Index	Safety Guide, Offer of Sale
-----------------------------	--------------	------------	------------	------------------	-------------------------------	-------------	-------------------	-----------------------------



For inventory, lead times, and kit lookup, visit www.pdnplu.com



Rodless Pneumatic Cylinders
P8S Electronic & Reed Sensors

P8S Sensors	
Features	162
Dimensional Data / Installation	163
Technical Data	164
Ordering Information	165
P8S Continuous Position Sensors (CPS)	
Features	166
Technical Data	167
Dimensional Data / Ordering Information	168
Accessories	169-170

Rodless Pneumatic Cylinders
OSP-P Series
P1X Series
GDL Series
2002/P120 Series
P5S Electronic & Reed Sensors
Accessories
Part Number Index
Safety Guide, Offer of Sale



For inventory, lead times, and kit lookup, visit www.pdnplu.com

P8S Electronic and Reed Sensors

The P8S Series magnetic cylinder sensor enables quick, precise and contactless sensing of the piston's position in cylinders. It is easy to mount, can be used in numerous applications and offers an outstanding price-performance ratio.

Product Overview

As the term magnetic switch suggests, these are operated by magnetic fields; another description widely used is magnetic "SENSOR". As our eyes sense change of light, our ears sense the change of sound, magnetic sensors / switches sense the change of magnetic flux in pneumatic and hydraulic cylinders. When magnetic sensors sense a magnetic field it will give a switching signal, through a control circuit, allowing sensing or control operation to be achieved.

Because of the characteristics of magnetic sensors they can sense a change of magnetic field relative to the position of the magnet, such as in a pneumatic or hydraulic cylinder, whereby the magnet is attached to a moving piston and thus the position of the moving part (ie Piston) can be detected.

The magnet is mounted on the piston of the cylinder and thus moves with the piston.

The magnetic sensor (switch) is fixed either directly to the cylinder or with an additional mounting bracket. When the piston (magnet) moves to the position under a magnetic sensor, the switch will operate due to the change of the magnetic field and give a switching signal.

Thus the position of the piston can be identified and a resulting signal generated to continue the sequence of a circuit.

Magnetic sensors available can be classified into two different groups, they are sensors with contacts which are called



mechanically operated or reed sensors and the other type is sensors without contacts and are called solid state type or electronic.

Parker P8S Series sensors are suitable for use with a large range of actuators. They can either be inserted directly into the cylinder tube extrusion or mounted using additional brackets. For direct mounting the sensor is positioned within the cylinder sensor groove, offering mechanical protection, then securely clamped into position by a simple turn of a screw. For other cylinder versions there are a number of optional sensors brackets that clamp to the cylinder and offer other mounting positions.

For easy installation there are several cable lengths available with either M8 connector or flying lead. The electronic sensors are "Solid State", i.e. they have no moving parts. They are provided with short-circuit protection and transient protection as standard. The built-in electronics make the sensors suitable for applications with high on and off switching frequency where long service life is required.

Please note that for low temperature applications sensors are normally specified for full performance down to -30°C only. High temperature cylinders do not have a magnetic piston and therefore cannot be used with sensors.

Technical Data - Square body design, insert straight in T-slot, screw 1/4 turn

	Electronic PNP NPN	Electric Reed
Cylinder type:	Profile with T-slot	
Cylinder type with adapter:	Profile with S-slot (dovetail) Tie rods Round cylinders	
Installation:	Quarter turn, fixed by allen key 2.5 mm or flathead screwdriver	
Housing length:	29.5 mm	29.5 mm 5 - 30 V AC/DC
	24 mm (NAMUR ATEX)	29.5 mm 5 - 120 V AC/DC 32.5 mm 5 - 230 V AC/DC
Output Type:	PNP NPN	Reed
Switching (on/off) switching frequency:	± 1,000 Hz	± 400 Hz
Output Function:	Normally Open (NO)	Normally Open (NO)
	Normally Closed (NC) 3-wire	Normally Closed (NC) 2-wire Normally Open (NO) 3-wire
Enclosure rating:	IP67	
	IP67 (NAMUR ATEX)	-
Supply Voltage:	8.2 to 20 V DC (NAMUR 1GD) 10 to 26 V DC (ATEX 3GD)	5 to 30 5 to 120 5 to 230 V AC/DC 2-wire, 3-wire depending on type
	<= 8 mA	-
Power consumption:	<= 10 mA (NAMUR, ATEX)	-
	<= 2 V	<= 3.5 V 2-wire <= 0.1 V 3-wire
Voltage drop:	<= 2.2 V (NAMUR, ATEX)	-
	<= 100 mA	<= 100 mA 3-wire
Continuous output current I_a:	<= 60 mA (NAMUR) <= 50 mA (ATEX)	<= 500 mA (DC) <= 300 mA (AC)
	-	<= 6 W

	Electronic PNP NPN	Electric Reed
Protection class:	III	III II 2-wire depending on type III 3-wire
	2.6 to 3.3 mT	2.1 to 3.4 mT
Response sensitivity:	2.8 mT (NAMUR, ATEX)	-
	10 mm	-
Overrun distance:	9 mm (NAMUR, ATEX)	-
	<= 0.8 mT	-
Hysteresis:	<= 0.5 mT (NAMUR, ATEX)	-
Repeatability:	<= 0.1 mT	-
Reverse polarity protection:	Yes	No 2-wire Yes 3-wire
	-	-
Short circuit protection:	Yes	-
Power-up pulse protection:	Yes (NAMUR, ATEX)	-
Ambient operating temperature range:	-30 to +80 °C (PUR cable) -30 to +70°C (PVC cable)	
	-25 to +80 °C (NAMUR 1GD) -20 to +50°C (ATEX 3GD)	
Shock and vibration resistance:	30 g 11 ms / 10 ... 55 Hz, 1 mm	
EMC:	According to EN 60947-5-2	
International standard:	CE C UL US RoHS Ex IEC IEC Ex	
Housing material:	Plastic polyamid PA12	
Screw material:	Stainless steel	
Cable material:	PUR (Polyurethane) PVC (Polyvinyl Chloride)	
Conductor cross-section:	0.14 mm ² 0,12 mm ² depending on type 0.14 mm ² (NAMUR, ATEX)	
Indication LED color:	Yellow, no LED reed NC	
Connector:	M8R (knurled nuts) None (Flying lead)	



For inventory, lead times, and kit lookup, visit www.pdnplu.com

Catalog 0961-1
Dimensional Data, Installation

Rodless Pneumatic Cylinders
P8S Sensors

Dimensions in mm (inch)

PNP, NPN Output 10 to 30 V DC

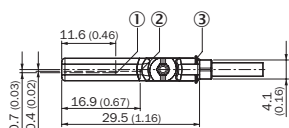
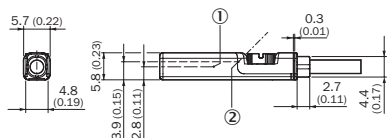

- ① Position sensor element
- ② Indication LED
- ③ Retaining ribs

Reed Output 5 to 230 V AC/DC

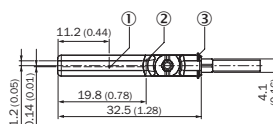
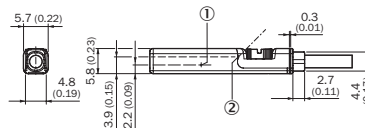

- ① Position sensor element
- ② Indication LED
- ③ Retaining ribs

Reed Output 5 to 30 V AC/DC

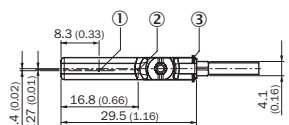
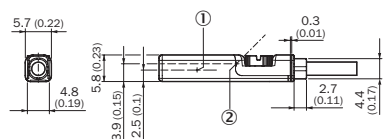

- ① Position sensor element
- ② Indication LED
- ③ Retaining ribs

Reed Output 5 to 120 V AC/DC

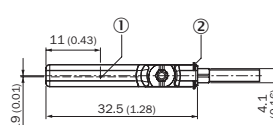
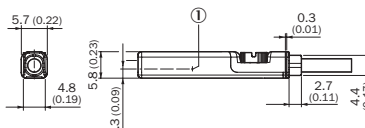

- ① Position sensor element
- ② Retaining ribs

NAMUR ATEX 1G, 1D, ATEX 3G, 3D

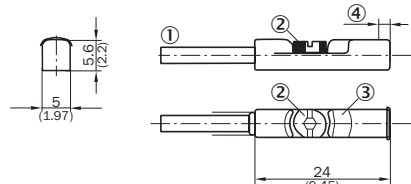

- ① Connection
- ② Fixing screw
- ③ Indication LED
- ④ Position of sensor element; short overrun distance: 2 mm; long overrun distance: 1.7 mm

Connector M8R

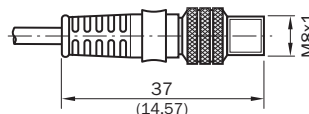

Installation

Square body design, Insert straight in T-slot, screw 1/4 turn

With Adapter in S-Dovetail Slot

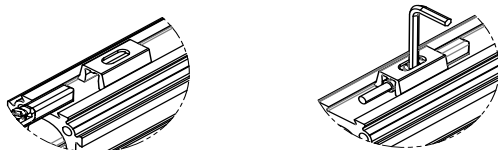

Note:
 The adapter is delivered with each sensor.

Without Adapter directly in T-Slot

Put-in straight

Screw 1/4 turn

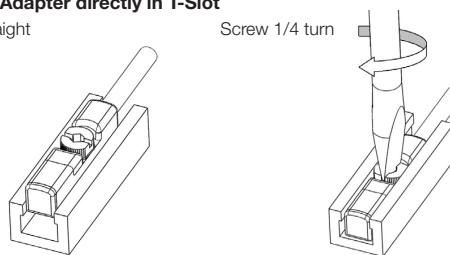

Rodless Pneumatic Cylinders
OSP-P Series
P1X Series
GDL Series
2002/P120 Series
P55 Electronic & Reed Sensors
Accessories
Part Number Index
Safety Guide, Offer of Sale



For inventory, lead times, and kit lookup, visit www.pdnplu.com

Rodless Pneumatic Cylinders
OSP-P Series
P1X Series
GDL Series
2002/P120 Series
P5S Electronic & Reed Sensors
Accessories
Part Number Index
Safety Guide, Offer of Sale

Connection type and diagram

PNP NO

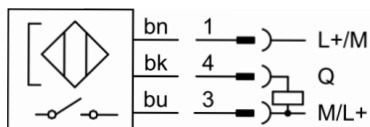

PNP NC

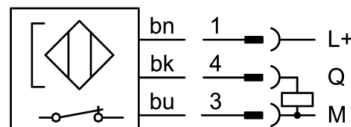

NPN NO

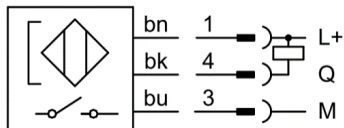

NPN NC

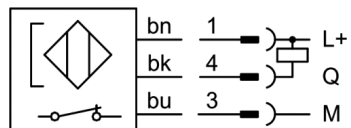

bn: brown
 bk: black
 bu: blue
 Q: load
 M: Mass
 L+: Power

Reed NO 3-wire

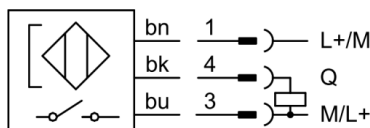

Reed NO 2-wire

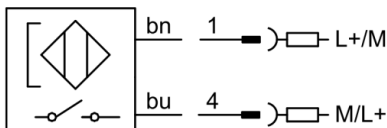

Reed NC 2-wire

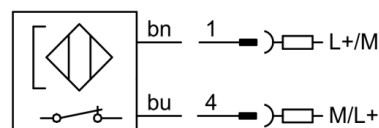

NAMUR NO ATEX 1G, 1D

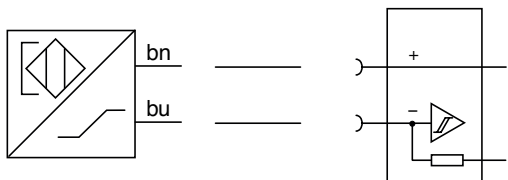

PNP NO ATEX 3G, 3D

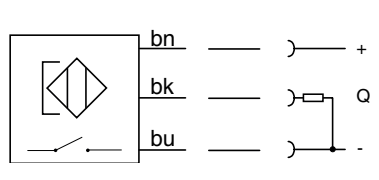

Pin assignment, M8 with knurled nut

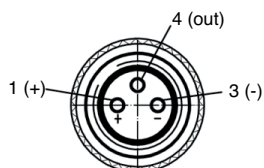

Flying leads

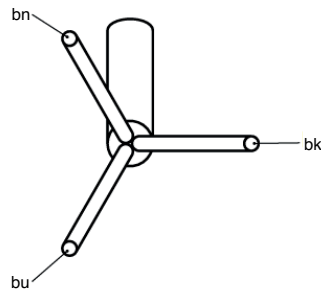

For inventory, lead times, and kit lookup, visit www.pdnplu.com

Square body design, Insert straight in T-slot, screw 1/4 turn

NPN NORMALLY CLOSED	VOLTAGE	CONNECTION	CABLE	Part Number
NPN-NC, with LED, 3-wire	10-30 V DC	3 m Flying Lead	PUR IP67	P8SAGMFAX
NPN-NC, with LED, 3-wire	10-30 V DC	10 m Flying Lead	PUR IP67	P8SAGMFDX
NPN-NC, with LED, 3-wire	10-30 V DC	0.3 m M8	PUR IP67	P8SAGMCHX
NPN NORMALLY OPEN	VOLTAGE	CONNECTION	CABLE	Part Number
NPN-NO, with LED, 3-wire	10-30 V DC	3 m Flying Lead	PUR IP67	P8SAGNFAX
NPN-NO, with LED, 3-wire	10-30 V DC	10 m Flying Lead	PUR IP67	P8SAGNFDX
NPN-NO, with LED, 3-wire	10-30 V DC	0.3 m M8	PUR IP67	P8SAGNCHX
PNP NORMALLY CLOSED	VOLTAGE	CONNECTION	CABLE	Part Number
PNP-NC, with LED, 3-wire	10-30 V DC	3 m Flying Lead	PUR IP67	P8SAGQFAX
PNP-NC, with LED, 3-wire	10-30 V DC	3 m Flying Lead	PVC IP67	P8SAGQFLX
PNP-NC, with LED, 3-wire	10-30 V DC	10 m Flying Lead	PUR IP67	P8SAGQFDX
PNP-NC, with LED, 3-wire	10-30 V DC	0.3 m M8	PUR IP67	P8SAGQCHX
PNP NORMALLY OPEN	VOLTAGE	CONNECTION	CABLE	Part Number
PNP-NO, with LED, 3-wire	10-30 V DC	3 m Flying Lead	PUR IP67	P8SAGPFAX
PNP-NO, with LED, 3-wire	10-30 V DC	3 m Flying Lead	PVC IP67	P8SAGPFLX
PNP-NO, with LED, 3-wire	10-30 V DC	10 m Flying Lead	PUR IP67	P8SAGPFDX
PNP-NO, with LED, 3-wire	10-30 V DC	10 m Flying Lead	PVC IP67	P8SAGPFTX
PNP-NO, with LED, 3-wire	10-30 V DC	0.3 m M8	PUR IP67	P8SAGPCHX
REED NORMALLY CLOSED	VOLTAGE	CONNECTION	CABLE	Part Number
Reed-NC, No LED, 2-wire	5-30 V AC/DC	10 m Flying Lead	PUR IP67	P8SAGEFRX
Reed-NC, No LED, 2-wire	5-120 V AC/DC	10 m Flying Lead	PUR IP67	P8SAGEFRX1
Reed-NC, No LED, 2-wire	5-30 V AC/DC	0.3 m M8	PUR IP67	P8SAGECNX
REED NORMALLY OPEN	VOLTAGE	CONNECTION	CABLE	Part Number
Reed-NO, with LED, 2-wire	5-30 V AC/DC	3 m Flying Lead	PUR IP67	P8SAGRFAFX
Reed-NO, with LED, 2-wire	5-120 V AC/DC	3 m Flying Lead	PVC IP67	P8SAGRFLX1
Reed-NO, with LED, 2-wire	5-230 V AC/DC	3 m Flying Lead	PVC IP67	P8SAGRFLX2
Reed-NO, with LED, 2-wire	5-230 V AC/DC	10 m Flying Lead	PUR IP67	P8SAGRFDX2
Reed-NO, with LED, 2-wire	5-120 V AC/DC	10 m Flying Lead	PVC IP67	P8SAGRFTX1
Reed-NO, with LED, 2-wire	5-30 V AC/DC	0.3 m M8	PUR IP67	P8SAGRCHX
REED NORMALLY OPEN	VOLTAGE	CONNECTION	CABLE	Part Number
Reed-NO, with LED, 3-wire	5-30 V AC/DC	3 m Flying Lead	PUR IP67	P8SAGSFAX
Reed-NO, with LED, 3-wire	5-30 V AC/DC	3 m Flying Lead	PVC IP67	P8SAGSFLX
Reed-NO, with LED, 3-wire	5-30 V AC/DC	10 m Flying Lead	PUR IP67	P8SAGSFDX
Reed-NO, with LED, 3-wire	10-30 V AC/DC	10 m Flying Lead	PVC IP67	P8SAGSFTX
Reed-NO, with LED, 3-wire	5-30 V AC/DC	0.3 m M8	PUR IP67	P8SAGSCHX
ATEX IP67	VOLTAGE	CONNECTION	CABLE	Order Code
PNP-NO, with LED, 3-wire	10-26 V DC	3 m Flying lead	PUR IP67	P8SAGPFAXS
NAMUR-NO, with LED, 2-wire	8.2-20 V DC	5 m Flying Lead	PVC IP67	P8SAGDFMXW *
NAMUR-NO, with LED, 2-wire	8.2-20 V DC	10 m Flying Lead	PVC IP67	P8SAGDFTXW *

Note:

-30 to +80 °C (PUR cable) | -30 to +70 °C (PVC cable) | -25 to +80 °C (NAMUR 1GD) | -20 to +50 °C (ATEX 3GD)

All sensors come with an adapter for S-dovetail Parker type OSP grooves.

* with an aluminium adapter

Rodless Pneumatic Cylinders
OSP-P Series
P1X Series
GDL Series
2002/P120 Series
P5S Electronic & Reed Sensors
Accessories
Part Number Index
Safety Guide, Offer of Sale

 For inventory, lead times, and kit lookup, visit www.pdnplu.com

Features

 Rodless Pneumatic
 Cylinders

P8S Continuous Position Sensors

Many applications require more than just end of stroke sensing of an actuator, but traditional methods of continuous sensing are expensive to implement. Parker's CPS (Continuous Position Sensor) enables quick, precise and contactless continuous position sensing of a magnetic piston.

CPS sensors continuously supply data via analog outputs or IO-Link. Analog position sensors have a voltage output of 0 V ... 10 V as well as a current output of 4 mA ... 20 mA. CPS enables flexible machine concepts, making it possible to solve tasks in areas such as quality monitoring and process control in conjunction with pneumatic cylinders. This continuous transfer of position data upgrades the functionality of the pneumatic cylinders by making them more intelligent, and as a result, more versatile. CPS settings can be adjusted during or after installation using a teach button or using IO-Link.

CPS can be mounted directly in standard T-slots without the need for additional accessories. Mounting on other cylinder types, (round, tie rod) is possible with adapters.

 OSP-P
 Series

- Continuous position sensing
- IO-Link communication with M12 connector
- No modification to the actuator
- Analog version with M8 connector
- 5 sizes with sensing ranges from 32 mm to 256 mm
- IP67 design suitable for any industrial application
- Yellow teach button for easy set-up

 P1X
 Series

 GDL
 Series

Technical specification:

1 ms sampling rate
 0.03% full scale resolution
 0.06% full scale repeatability
 0.3 mm Linearity error

 2002/P120
 Series

How it works:

The CPS product detects the position of an actuator via the magnet on the piston. The sensor settings can easily be adjusted during installation using the yellow teach button or during operation over the IO-Link communication. This upgrades the functionality of the pneumatic actuator by making it more intelligent and versatile in support of the Industry 4.0 initiative.

How it connects:

Analog version has a M8 connector and a voltage output of 0-10V as well as a current output of 4-20mA. IO-Link version has a M12 connector and transmits position via 2 bytes of process input data and also allows for parameter control of measuring range and locking of the teach button. It can be controlled by Class A or Class B IO-Link Masters.

 P5S Electronic &
 Reed Sensors

Accessories

How it installs:

 Part Number
 Index

 Safety Guide,
 Offer of Sale



The Parker CPS requires the use of a magnetic piston. The product will fit T-slot cylinders without any additional mounting hardware.

Without Adapter:

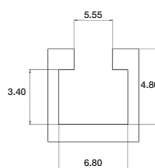
Direct drop-in T-slot
 T-slot dimensions [mm ± 0.1]

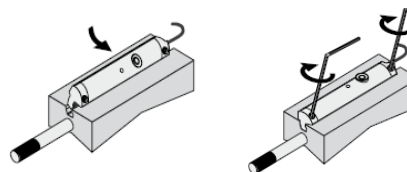

- 1) Pivot sensor into the slot
- 2) Teach the CPS unit the desired measuring range
- 3) Tighten set screws



For inventory, lead times, and kit lookup, visit www.pdnplu.com

Technical Data

Cylinder type:	Profile with T-slot
Installation:	Drop in, fixed by allen key 1.5 mm
Measuring range:	32 to 256 mm depending on type ¹⁾
Housing length:	45 to 269 mm depending on type
Output Function:	Analog I IO-Link
Analog output (voltage):	0 to 10 V I -
Analog output (current):	4 to 20 mA I -
Teach-in:	Yes
Enclosure rating:	IP 67 (according to EN 60529)
Supply Voltage: ²⁾	15 to 30 V DC
Power consumption: ³⁾	<= 22 mA (analog) <= 25 ma (IO-Link)
Max load resistance: ⁴⁾	<= 500 Ω
Min load resistance: ⁵⁾	<= 2 kΩ
Protection class:	III
Time delay before availability:	1.5 s
Required magnetic field sensitivity:	3 mT / 2 mT (analog) 3 mT (IO-Link)
Resolution: ⁶⁾	0.03% full scale range (max >=0.05 mm)
Linearity error: ⁷⁾	0.3 mm
Repeat accuracy: ⁸⁾	0.06% full scale range (>= 0.1 mm)
Sampling rate: ⁹⁾	1 ms
Indication LED color:	Yellow (analog)
Reverse polarity protection:	Yes (analog)
Short circuit protection:	Yes (analog)
Ambient operating temperature range:	-20 to +70 °C (PUR cable)
Shock and vibration resistance:	30 g 11 ms / 10 ... 55 Hz, 1 mm
EMC: ¹⁰⁾	According to EN 60947-5-2
International standard:	CE C UL US CCC (not applicable) RoHs IO-Link
UL file No:	On request
Housing material:	Plastic polyamid PA12
Screw material:	Stainless steel
Cable material:	PUR (Polyurethane)
Conductor cross-section:	0.08 mm ²
Connector:	M12 (IO-Link) or M8 (analog)



- ¹⁾ ± 1 mm
- ²⁾ Reverse-polarity protected, operation in short-circuit protected network: max. 8 A.
- ³⁾ Without load
- ⁴⁾ Power output, at 24 V
- ⁵⁾ Voltage output
- ⁶⁾ FSR: Full Scale Range; max. measuring range.
- ⁷⁾ At 25 °C, linearity error (maximum deviation) depending on response curve and minimal deviation function.
- ⁸⁾ At 25 °C, repeatability magnet movement in one direction.
- ⁹⁾ Only in standard mode, not in IO-Link mode.
- ¹⁰⁾ The analogue measured value can deviate under transient conditions.

Rodless Pneumatic Cylinders
OSP-P Series
P1X Series
GDL Series
2002/P120 Series
P5S Electronic & Reed Sensors
Accessories
Part Number Index
Safety Guide, Offer of Sale



For inventory, lead times, and kit lookup, visit www.pdnplu.com

Mountings and brackets

For products series	Part Number	Weight [g]
T-Slot OSP Ø 10	8872FIL	3
T-Slot P Series Ø 16	8865FIL	4
T-Slot P Series Ø 25-80	8866FIL	5
S-Dovetail OSP, pack of 10	P8S-TMA09	10

Ambient temperature -30 to +80 °C

All mountings can be moved on the cylinder body before screwing in place and then putting sensors in the slots.

Sensor adapter bracket (Used with P1X Series)

Part number **P8S-TMA0Y**
 (Shown larger than actual size)

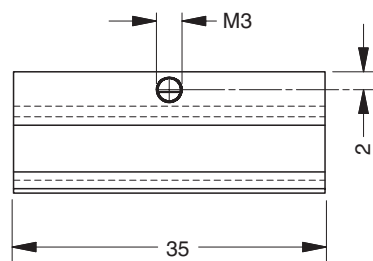
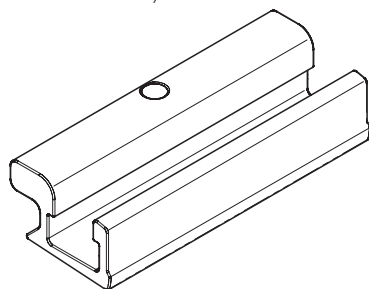

NOTE: Must be ordered separately when ordering sensors.

Rodless Pneumatic Cylinders
OSP-P Series
P1X Series
GDL Series
2002/P120 Series
P5S Electronic & Reed Sensors
Accessories
Part Number Index
Safety Guide, Offer of Sale



For inventory, lead times, and kit lookup, visit www.pdnplu.com

Rodless Pneumatic Cylinders

Male connectors for connecting cables

Cable connectors for producing your own connecting cables. The connectors can be quickly attached to the cable without special tools. Only the outer sheath of the cable is removed. The connectors are available for M8 screw connector and meet protection class IP65.

Technical Data

Operating voltage:	max. 32 V AC/DC
Operating current per contact:	max. 4 A
Connection cross section:	0.25... 0.5 mm ² (conductor diameter min 0.1 mm)
Protection class:	IP65 and IP67 when plugged and screwed down (EN 60529)
Temperature range:	- 25... + 85°C

OSP-P Series

P1X Series

Connector	Weight [kg]	Part number
M8 screw connector		P8CS0803J
M12 screw connector	0.022	P8CS1204J



GDL Series

Cables to extend cable sensor lengths with M8*

Description	Part number	Weight [g]	For Product Series
Cable flex PVC 3 meter with 8mm snap-in connector / flying leads	9126344341	70	P8S Sensors with M8
Cable flex PVC 10 meter with 8mm snap-in connector / flying leads	9126344342	210	P8S Sensors with M8
Cable PUR 3 meter with 8mm snap-in female connector / flying leads	9126344345	70	P8S Sensors with M8
Cable flex PUR 10 meter with 8mm snap-in connector / flying leads	9126344346	210	P8S Sensors with M8
Cable PVC 2.5 meter with M8 screw connector / flying leads	KC3102	60	P8S Sensors with knurled M8
Cable PVC 5 meter with M8 screw female connector / flying leads	KC3104	120	P8S Sensors with knurled M8

2002/P120 Series

P5S Electronic & Reed Sensors

*Note: not applicable for P8S CPS Sensors as no cable available

Accessories

Part Number Index

Safety Guide, Offer of Sale



For inventory, lead times, and kit lookup, visit www.pdnplu.com



Air Preparation Products
Airline Accessories

Flow Controls & Check Valves

337 Micrometer Series	172
338 Series	173
3250 Series	174
3251 Series	175
339 Series	176
3047 Series	177

Miscellaneous Accessories

EM Series Sintered Bronze Muffler / Filters	178
Muffler / Flow Controls	178
Breather Vents	179
Silencers	179
Air Line Silencers, Plastic	180-181
ECS Reclassifier	182
Drains	183-185
Lockout Valves	186-191
AirGuard Protection System	192-193
Quick Exhaust & Shuttle Valves	194-196
Threshold Sensors, PWS Series	197-199
Tank Valves	200
Blow Guns	201-202

Integrated Fittings

Index	203-204
Compact Flow Control Valves	205-206
Miniature Flow Control Valves	207
Swivel Outlet Flow Control Valves	208
Plug-In Flow Control Valves	209
In-Line Flow Control Valves	210-211
Compact Metal Flow Control Valves	212
Flow Control Check Valves	213-214
Blocking Flow Control Valves	215
Threshold Sensors	216

Rodless Pneumatic Cylinders
OSP-P Series
P1X Series
GDL Series
2002/P120 Series
P5S Electronic & Reed Sensors
Accessories
Part Number Index
Safety Guide, Offer of Sale



For inventory, lead times, and kit lookup, visit www.pdnplu.com

Rodless Pneumatic Cylinders

OSP-P Series

P1X Series

GDL Series

2002/P120 Series

P5S Electronic & Reed Sensors

Accessories

Part Number Index

Safety Guide, Offer of Sale

337 Series Micrometer Flow Control Valves, 1/8" to 3/4" Ports

The "337" Series Flow Control Valves meter flow of air in one direction and allow free flow in the reverse direction.

Valves are manufactured with a fine tapered needle providing precise flow control, even at low flow rates. The perimeter of the adjustment knob features numerical micrometer position markings providing a visual indication of the setting. Once the desired flow is selected, a set screw can be tightened to maintain the setting.

These valves are available with NPTF ports in 1/8", 1/4", 3/8", 1/2", and 3/4" sizes. This series is recommended for pneumatic service.



Material Specifications

Body	Brass
Check Seal	Urethane
Knob	Aluminum
Needle	Stainless steel
Needle Seals	Buna N (Fluorocarbon optional – consult factory)
Retainer	Zinc- Plated Steel
Spring	Stainless Steel
Set Screw	Steel

Operating information

Maximum operating pressure: 250 PSIG
Cracking pressure for return check poppet 1 to 2 PSIG

Operating temperature:*
Standard: 0°F to 180°F
Extended: 0°F to 300°F (consult factory)

* Ambient temperatures below freezing require moisture-free air. Ambient temperatures below freezing and above 180° require lubricants especially selected for suitability at these temperatures. Pneumatic valves should be used with filtered and lubricated air.

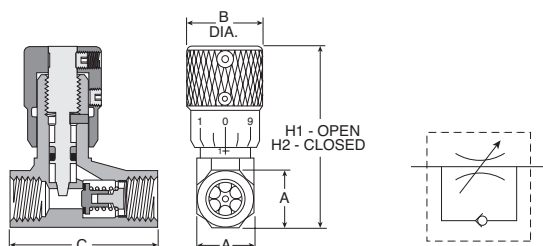

337 Micrometer Flow Control Valves – NPT

Port Size	Flow (SCFM †)		A	B	C	H1	H2	Part Number	Service Kits
	Adj.	Free Flow							
1/8"	15	32	9/16"	0.75	1.47	2.03	1.81	003371000	003378000
1/4"	28	75	11/16"	0.75	1.47	2.28	2.03	003371001	003378001
3/8"	59	139	7/8"	0.88	2.31	2.84	2.53	003371002	003378002
1/2"	126	183	1-3/16"	1.06	3.25	3.62	3.22	003371003	003378003
3/4"	140	327	1-3/8"	1.06	3.25	3.72	3.31	003371004	003378004

337 Micrometer Flow Control Valves – BSPP

Port Size	Flow (SCFM †)		A	B	C	H1	H2	Part Number	Service Kits
	Adj.	Free Flow							
1/8"	15	32	9/16"	0.75	1.47	2.03	1.81	00337G1000	003378000
1/4"	28	75	11/16"	0.75	1.47	2.28	2.03	00337G1001	003378001

† At 100 PSIG inlet pressure with full pressure drop.

Most popular.



For inventory, lead times, and kit lookup, visit www.pdnplu.com

338 Series Flow Control Valves, 1/8" to 3/4" Ports

"338" Series needle valves bi-directionally meter the flow of air through the valve.

This series features a fine tapered needle providing precise flow of air in both directions. Numerical micrometer position markings are stamped on the perimeter of the adjustment knob which provide a visual indication of the setting. Once the desired flow is selected, a set screw can be tightened to maintain the setting.

These valves are available with NPTF ports in 1/8", 1/4", 3/8", 1/2" and 3/4" sizes. This series is recommended for pneumatic service.



Material Specifications

Body	Brass
Internal Components	Stainless steel
Seals	Buna N (Fluorocarbon optional – consult factory)

Operating information

Maximum operating pressure:	250 PSIG
Operating temperature*:	
Standard:	0°F to 180°F
Extended:	0°F to 300°F (consult factory)
* Ambient temperatures below freezing require moisture-free air. Ambient temperatures below freezing and above 180° require lubricants especially selected for suitability at these temperatures. Pneumatic valves should be used with filtered and lubricated air.	

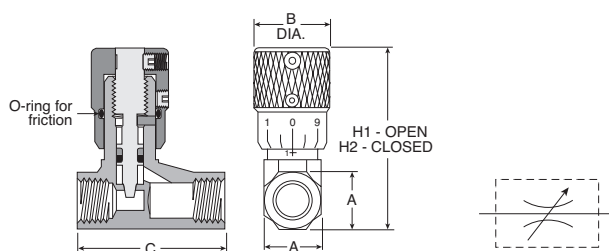

338 Needle Valves – NPT

Port Size	Flow (SCFM †)	A	B	C	H1	H2	Part Number	Service Kits
1/8"	15	9/16"	0.75	1.47	2.03	1.81	003381100	003378000
1/4"	28	11/16"	0.75	1.47	2.28	2.03	003381101	003378001
3/8"	59	7/8"	0.88	2.31	2.84	2.53	003381102	003378002
1/2"	126	1-3/16"	1.06	3.25	3.62	3.22	003381103	003378003
3/4"	140	1-3/8"	1.06	3.25	3.72	3.31	003381104	003378004

338 Needle Valves – BSPP

Port Size	Flow (SCFM †)	A	B	C	H1	H2	Part Number	Service Kits
1/8"	15	9/16"	0.75	1.47	2.03	1.81	00338G1100	003378000
1/4"	28	11/16"	0.75	1.47	2.28	2.03	00338G1101	003378001

† At 100 PSIG inlet pressure with full pressure drop.

Most popular.



For inventory, lead times, and kit lookup, visit www.pdnplu.com

Rodless Pneumatic Cylinders
OSP-P Series
P1X Series
GDL Series
2002/P120 Series
P5S Electronic & Reed Sensors
Accessories
Part Number Index
Safety Guide, Offer of Sale

Rodless Pneumatic Cylinders

OSP-P Series

P1X Series

GDL Series

2002/P120 Series

P55 Electronic & Reed Sensors

Accessories

Part Number Index

Safety Guide, Offer of Sale

3250 Series Flow Control Valves, 1/8" to 3/4" Ports

The "3250" Series Flow Control Valves are specifically designed to accurately meter the flow of air in one direction and allow free flow in the opposite direction. The "3250" Series Flow Control Valves are also suitable for low pressure hydraulic service.

When air is moving in the free flow direction through the valve, it forces the poppet off its seat and unrestricted air flow is permitted.

When air is moving in the metered direction through the valve, air pressure and the force of the poppet spring causes the poppet to close. Flow must then be through the orifice that is controlled by the metering screw. Opening this screw allows more flow; closing it, less flow.



Material Specifications

Body	Brass
Internal Components	Brass, Stainless steel
Seals	Buna N

Operating information

Operating pressure: 250 PSIG (Air)
250 PSIG (Hydraulic)

Operating temperature:
Standard: 0°F to 180°F
Extended: 0°F to 300°F

Valve will operate mounted in any position. Lock nut on metering screw prevents change in setting during operation.

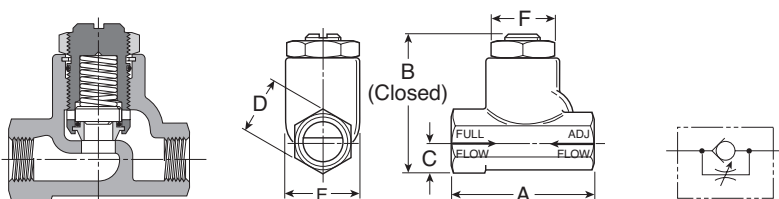

3250 Flow Control Valves, 1/8" to 3/4" Ports – NPT

Port Size	Max. flow (SCFM)		A	B	C	D	E	F	Part Number
	Metered Direction	Free flow Direction							
1/8"	70	60	1.75	1.56	0.37	0.62	0.81	0.68	032500119
1/4"	130	120	2.33	1.97	0.44	0.75	1.09	0.94	032500219
3/8"	220	205	2.66	2.44	0.56	1.00	1.38	1.19	032500319
1/2"	295	346	3.11	3.06	0.75	1.25	1.63	1.38	032500419
3/4"	420	615	3.56	3.69	0.88	1.50	2.00	1.75	032500519

3250 Flow Control Valves, 1/8" to 3/4" Ports – BSPP

Port Size	Max. flow (SCFM)		A	B	C	D	E	F	Part Number
	Metered Direction	FreeCion							
1/8"	70	60	1.75	1.56	0.37	0.62	0.81	0.68	3250G0119
1/4"	130	120	2.33	1.97	0.44	0.75	1.09	0.94	3250G0219
3/8"	220	205	2.66	2.44	0.56	1.00	1.38	1.19	3250G0319
1/2"	295	346	3.11	3.06	0.75	1.25	1.63	1.38	3250G0419
3/4"	420	615	3.56	3.69	0.88	1.50	2.00	1.75	3250G0519

Most popular.



For inventory, lead times, and kit lookup, visit www.pdnplu.com

3250 Series Needle Valves, 1" to 1-1/2" Ports

These extra large flow control valves have been developed to provide effective flow settings for large diameter cylinders and for other similar air applications. Each valve has a fine screw adjustment allowing precise settings which are secured by a sturdy lock nut.

Large internal port passages coupled with unique soft seal poppet and inline design provide maximum full flow capacity and minimum pressure drop in the free flow direction. Their cone shaped brass metering valve will provide consistent cylinder speed by regulating cylinder exhaust.



Material Specifications

Body	Cast Aluminum
Internal Components	Brass, Aluminum
Seals	Buna N, Urethane
Spring	Stainless Steel

Operating information

Maximum operating pressure:	250 PSIG
Operating temperature:	
Standard:	-40°F to 180°F
Extended:	-40°F to 350°F (consult factory)

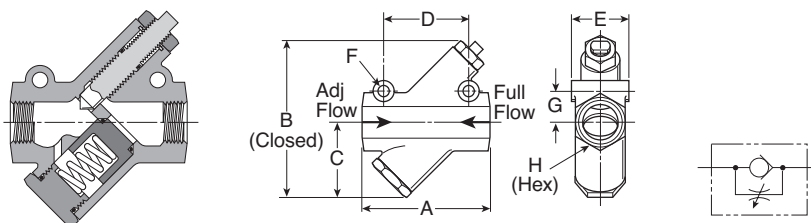

3250 Flow Control Valves, 1" to 1-1/2" Ports – NPT

Port Size	Max. Flow Needle Open		A	B	C	D	E	F	G	H	Part Number
	SCFM †	Cv									
1"	1000	12.3	5.00	6.50	3.00	3.25	2.25	.39	1.31	2.13	032501000
1-1/4"	1200	13.8	5.00	6.50	3.00	3.25	2.25	.39	1.31	2.13	032501250
1-1/2"	1800	17.5	5.88	8.00	3.75	3.50	2.50	.39	1.50	2.38	032501500

3250 Flow Control Valves, 1" to 1-1/2" Ports – BSPP

Port Size	Max. Flow Needle Open		A	B	C	D	E	F	G	H	Part Number
	SCFM †	Cv									
1"	1000	12.3	5.00	6.50	3.00	3.25	2.25	.39	1.31	2.13	03250G1000
1-1/4"	1200	13.8	5.00	6.50	3.00	3.25	2.25	.39	1.31	2.13	03250G1250
1-1/2"	1800	17.5	5.88	8.00	3.75	3.50	2.50	.39	1.50	2.38	03250G1500

† At 100 PSIG inlet pressure with full pressure drop.

Most popular.



For inventory, lead times, and kit lookup, visit www.pdnplu.com

Rodless Pneumatic Cylinders
OSP-P Series
P1X Series
GDL Series
2002/P120 Series
P55 Electronic & Reed Sensors
Accessories
Part Number Index
Safety Guide, Offer of Sale

3251 Series Right Angle Flow Control Valves, 1/8" to 1/2" Ports

The Right Angle Flow Control is an ideal solution to cylinder speed control where space is at a premium. Costly fittings, connections and piping expenses can be eliminated because the valve can rotate 360°, the piping alignment can be in any direction. It then locks into place. The 1/8" model can be rotated after final assembly.

Install by threading male end directly into cylinder port. The free-flow and metered-flow direction is automatically predetermined. Free-flow direction is into cylinder and metered-flow is out of the cylinder. Flow is adjusted with an Allen wrench and locked with nut.

Right Angle Flow Control also available with Prestolok fittings on inlet port to accommodate 5/32 - 3/8 tube sizes. This allows for quick connection and eliminates need for separate tube fitting.



Shown with Threaded Inlet



Shown with Prestolok Inlet Fitting

Operating information

Operating pressure: 125 PSIG (863 kPa) max.
Operating temperature: 0°F to 140°F (-18°C to 60°C)

Material Specifications

Body	Brass
Plunger	Brass and Acetal
Seals	Buna N

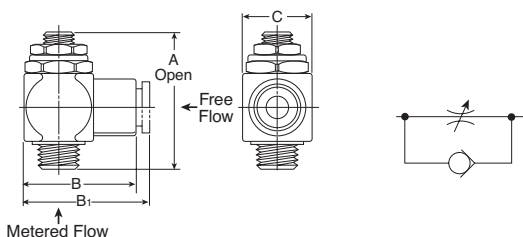

3251 Flow Control Valves – NPT

Thread (NPT) Male	Thread (NPT) Female	Cv		A mm	B mm	C mm	Weight		Part Number
		Adjusted Flow	Free Flow				oz.	kg.	
1/8	1/8	0.26	0.20	44	30	17	2.0	0.9	032510125
1/4	1/4	0.75	0.68	51	36	23	4.5	2.0	032510250
3/8	3/8	0.84	0.72	58	43	27	7.0	3.2	032510375
1/2	1/2	1.64	1.41	68	53	32	11.0	5.0	032510500
With Prestolok Fittings									
1/8	5/32	0.19	0.16	44	30	17	2.0	0.9	032511215
1/8	1/4	0.28	0.22	44	30	17	2.0	0.9	032511225
1/4	1/4	0.51	0.44	51	36	23	4.5	2.0	032512525
1/4	3/8	0.62	0.53	51	36	23	4.5	2.0	032512538
3/8	3/8	0.78	0.65	58	43	27	7.0	3.2	032513838

CAUTION: If it is possible that the ambient temperature may fall below freezing, the medium must be moisture-free to prevent internal damage or unpredictable behavior.

Most popular.



For inventory, lead times, and kit lookup, visit www.pdnplu.com

339 Series Check Valves, 1/8" to 3/4" Ports

"339" Series check valves allow free flow in one direction and provide positive checked flow in the reverse direction. These valves are available with NPTF ports in 1/8", 1/4", 3/8", 1/2" & 3/4" sizes. This series is recommended for pneumatic service.



Material Specifications

Body	Brass
Internal Components	Brass / stainless steel / zinc-plated steel
Seals	Urethane (standard) Fluorocarbon (optional, consult factory)

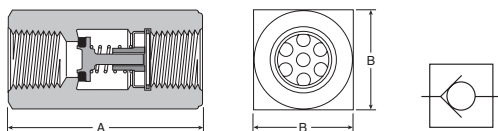

Operating information

Operating pressure: 250 PSIG max.
Cracking pressure 1 to 2 PSIG

Operating temperature:*
Standard: 0°F to 180°F
Extended Option: 0°F to 300°F (consult factory)

* Ambient temperatures below freezing require moisture-free air. Ambient temperatures below freezing and above 180° require lubricants especially selected for suitability at these temperatures. Pneumatic valves should be used with filtered and lubricated air.

339 Check Valve

Port Size	Flow (SCFM †)	A	B	Part Number	
				NPT	BSPP
1/8"	35	1.22	0.56	003393000	00339G3000
1/4"	75	1.34	0.69	003393001	00339G3001
3/8"	143	2.00	0.88	003393002	-
1/2"	162	2.56	1.19	003393003	-
3/4"	323	2.66	1.38	003393004	-

† At 100 PSIG inlet pressure with full pressure drop.

3047 Series Check Valves, 1/4" Ports

"3047" Series check valves allow free flow in one direction and provide positive checked flow in the reverse direction. This valve is available with a male 1/4" NPTF connection and is recommended for pneumatic service.



Material Specifications

Body	Brass
Internal Components	Brass / stainless steel
Seals	Nitrile

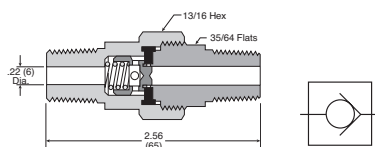

Operating information

Operating pressure: 250 PSIG max.
Cracking pressure 1 to 2 PSIG

Operating temperature:*
Standard: 0°F to 180°F

* Ambient temperatures below freezing require moisture-free air. Ambient temperatures below freezing and above 180° require lubricants especially selected for suitability at these temperatures. Pneumatic valves should be used with filtered and lubricated air.

3047 Check Valve

Port size	Flow (SCFM †)	Part Number
1/4"	30	030470099

† At 100 PSIG inlet pressure with full pressure drop.

Most popular.



For inventory, lead times, and kit lookup, visit www.pdnplu.com

Rodless Pneumatic Cylinders
OSP-P Series
P1X Series
GDL Series
2002/P120 Series
P55 Electronic & Reed Sensors
Accessories
Part Number Index
Safety Guide, Offer of Sale

EM Series – Sintered Bronze Muffler / Filters

Muffler / filters effectively reduce air exhaust noises to an industry accepted level with minimum flow restriction. They protect valves, impact wrenches, screw drivers and other air tools by preventing dirt and other foreign matter from entering the system. Non-corrosive. Can be cleaned with many common solvents.

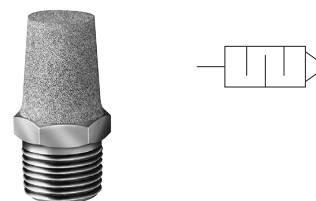

EM Series

Pipe Thread	Overall Length	Hex Size	Part Number
M5	.75	5/16"	EMM5
1/8"	1.00	7/16"	EM12
1/4"	1.32	9/16"	EM25
3/8"	1.54	11/16"	EM37
1/2"	1.85	7/8"	EM50
3/4"	2.29	1-1/6"	EM75
1"	2.91	1-5/16"	EM100
1-1/4"	3.25	1-11/16"	EM125
1-1/2"	3.69	2"	EM150

Operating information

Operating pressure: 250 PSIG (Air)
Cracking pressure 1 to 2 PSIG

Operating temperature:* 0°F to 300°F

* Ambient temperatures below freezing require moisture-free air. Ambient temperatures below freezing and above 180° require lubricants especially selected for suitability at these temperatures. Pneumatic valves should be used with filtered and lubricated air.

Muffler / Flow Controls

Muffler / flow controls provide an acceptable exhaust noise level and effectively meter exhaust. Installed in valve exhaust ports, they control cylinder piston speeds throughout a wide range. The adjusting screw cannot be accidentally blown out, can be locked to maintain setting. Brass and bronze construction. Clean with commonly used solvents.

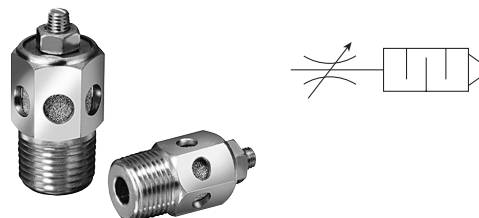

Muffler / Flow Controls

Pipe Thread	Overall Length	Hex Size	Part Number
1/8"	1.15	9/16"	045020002
1/4"	1.42	1/2"	045040004
3/8"	1.49	11/16"	045060060
1/2"	1.77	7/8"	045080080
3/4"	1.98	1-1/16"	045120012
1"	2.15	1-5/16"	045160016

Operating information

Operating pressure: 250 PSIG (Air)
Cracking pressure 1 to 2 PSIG

Operating temperature:* 0°F to 300°F

* Ambient temperatures below freezing require moisture-free air. Ambient temperatures below freezing and above 180° require lubricants especially selected for suitability at these temperatures. Pneumatic valves should be used with filtered and lubricated air.

Most popular.



For inventory, lead times, and kit lookup, visit www.pdnplu.com

Breather Vents

These low silhouette versions of the muffler / filter are useful where space is a problem and / or to prevent contamination. Use for vacuum relief or pressure equalization in gear boxes, oil tanks, reservoirs, etc. Non-corrosive.



Breather Vent

Pipe Thread	Overall Length	Hex Size	Part Number
1/8"	0.44	7/16"	047020002
1/4"	0.63	9/16"	047040004
3/8"	0.75	11/16"	047060006
1/2"	0.88	7/8"	047080008
3/4"	1.00	1-1/8"	047120012
1"	1.31	1-5/16"	047160016
1-1/4"	1.41	1-11/16"	047200020
1-1/2"	1.50	2"	047240024

NOTE: Breather vents should not be used as exhaust mufflers.

Operating information

Operating pressure: 150 PSIG (Air) max.
Operating temperature:* 0°F to 300°F

* Ambient temperatures below freezing require moisture-free air. Ambient temperatures below freezing and above 180° require lubricants especially selected for suitability at these temperatures. Pneumatic valves should be used with filtered and lubricated air.

ES Series – Silencer

The silencer is designed to give superior performance in noise control with a minimum effect on air efficiency. "Trimline" design allows location in the tightest places without extra plumbing and fittings. Fits directly into the exhaust port of more than 90% of present commercial valves. Slotted body permits rapid discharge of air without undesirable back pressure. Unique nylon screen element resists dirt buildup or clogging.

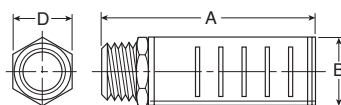

Operating information

Operating pressure: 250 PSIG (Air) max.
Operating temperature:* 0°F to 300°F

* Ambient temperatures below freezing require moisture-free air. Ambient temperatures below freezing and above 180° require lubricants especially selected for suitability at these temperatures. Pneumatic valves should be used with filtered and lubricated air.

ES Series – Silencer

Pipe Thread	Flow SCFM @ 100 PSIG inlet	Dimensions			Part Numbers	
		A	B	D	NPTF	BSPT (R)
1/8"	115	1.85	0.81	0.63	ES12MC	ESB12MC
1/4"	129	1.85	0.81	0.63	ES25MC	ESB25MC
3/8"	219	3.31	1.26	1.00	ES37MC	ESB37MC
1/2"	549	3.31	1.26	1.00	ES50MC	ESB50MC
3/4"	893	4.56	2.01	1.62	ES75MC	ESB75MC
1"	1,013	4.56	2.01	1.62	ES100MC	ESB100MC
1-1/4"	1,486	5.69	2.88	—	ES125MC	ESB125MC
1-1/2"	1,580	5.69	2.88	—	ES150MC	ESB150MC

Most popular.



For inventory, lead times, and kit lookup, visit www.pdnplu.com

Rodless Pneumatic Cylinders
OSP-P Series
P1X Series
GDL Series
2002/P120 Series
P55 Electronic & Reed Sensors
Accessories
Part Number Index
Safety Guide, Offer of Sale

ASN Air Line Silencer, Plastic

- Compact
- Lightweight
- Easy to Install
- Excellent Noise Reduction
- Protects Components from Contamination
- NPT and BSPT Threads Available

The plastic silencer is designed to give excellent noise reduction with a minimum effect on air efficiency. The "Trimline" design allows for locating the silencer in the tightest places without extra plumbing or fittings. Fits directly into the exhaust port of most commercial valves. Open surface area of element allows for rapid discharge of air without undesirable back pressure.

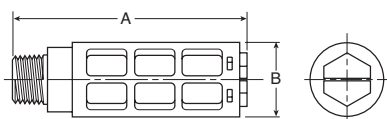

Operating information

Operating pressure:	0 to 150 PSIG (0 to 10 bar, 0 to 1034 kPa)
Operating temperature:	14°F to 140°F (-10°C to 60°C)

Material Specifications

Body	Acetal (Plastic)
Element	Polyethylene

ASN Air Line Silencer, Plastic

Thread Size	A (mm)	B (mm)	Maximum Flow (SCFM) 100 PSIG Inlet	Sound Pressure Level (dBA)		Part Number	
				20 PSIG inlet	100 PSIG inlet	NPT	BSPT
M5	0.43 (11)	0.32 (8)	15	69	79	AS-5	
1/8"	1.57 (40)	0.63 (16)	51	69	81	ASN-6	AS-6
1/4"	2.56 (65)	0.83 (21)	124	67	84	ASN-8	AS-8
3/8"	3.35 (85)	0.98 (25)	247	83	98	ASN-10	AS-10
1/2"	3.74 (95)	1.18 (30)	370	69	96	ASN-15	AS-15

Most popular.



For inventory, lead times, and kit lookup, visit www.pdnplu.com

P6M G Thread Air Line Silencer, Plastic

- All Plastic Ultra Light Weight Versions
- High Noise Level Reduction
- Low Back Pressure Generation

The plastic silencer is designed to give excellent noise reduction with a minimum effect on air efficiency. The "Trimline" design allows for locating the silencer in the tightest places without extra plumbing or fittings. Fits directly into the exhaust port of most commercial valves. Open surface area of element allows for rapid discharge of air without undesirable back pressure.

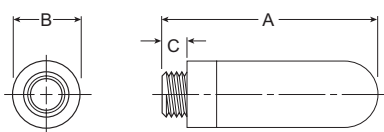
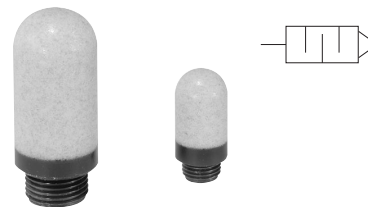

Operating information

Operating pressure:	0 to 246 PSIG (0 to 17 bar, 0 to 1700 kPa)
Operating temperature:	Plastic: 14°F to 176°F (-10°C to 80°C) Metal: 14°F to 165°F (-10°C to 74°C)
Efficiency	92%

P6M G Thread, Air Line Silencer, Plastic

Port Thread	A	Diameter B	C	Weight (grams)	Part Number
M5	0.91 (23)	0.26 (6,5)	0.16 (4)	0.01	P6M-PAC5
G1/8	1.14 (29)	0.55 (14)	0.24 (6)	0.02	P6M-PAB1
G1/4	1.34 (34)	0.67 (17)	0.24 (6)	0.04	P6M-PAB2
G3/8	2.36 (60)	0.98 (25)	0.35 (9)	0.06	P6M-PAB3
G1/2	2.52 (64)	0.98 (25)	0.43 (11)	0.10	P6M-PAB4
G3/4	5.51 (140)	1.50 (38)	0.55 (14)	0.50	P6M-PAB6
G1	6.30 (160)	1.89 (48)	0.79 (20)	0.62	P6M-PAB8

Most popular.



For inventory, lead times, and kit lookup, visit www.pdnplu.com

Rodless Pneumatic Cylinders
OSP-P Series
P1X Series
GDL Series
2002/P120 Series
P5S Electronic & Reed Sensors
Accessories
Part Number Index
Safety Guide, Offer of Sale

Rodless Pneumatic Cylinders

OSP-P Series

P1X Series

GDL Series

2002/P120 Series

P5S Electronic & Reed Sensors

Accessories

Part Number Index

Safety Guide, Offer of Sale

ECS Reclassifier, Air Line Muffler

The ECS (Muffler-Reclassifier) eliminates unwanted oil mist and reduces exhaust noise from pneumatic valves, cylinders and air motors.

- 99.97% Oil Removal Efficiencies
- 25 dBA Noise Attenuation
- 1/2" NPT and 1" NPT
- Disposable Units
- Continuous or Plugged Drain Option
- Metal Retained Construction
- Fast Exhaust Time

Improve Overall Plant Environment

Exhaust oil mist and noise pollution have a direct impact on worker productivity.

Oil aerosol mist from lubricators and compressors is pervasive and enters the industrial plant environment through the exhaust ports of valves, cylinders and air motors. This rapidly expanding exhaust also produces sudden and excessive noise.

The ECS (Muffler-Reclassifier) is 99.97% efficient at removing the oil aerosols. The ECS also acts as a silencer to lower the dBA levels below O.S.H.A. requirements.

The result is a cleaner, quieter environment which equates to greater work productivity and safety.

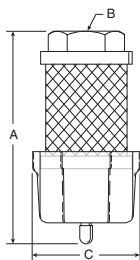

ECS Reclassifier, Air Line Muffler

Thread Size	A	B	C	Part Number
1/2	5.30 (135 mm)	1/2" NPT	2.57 (65 mm)	ECS3
1	7.30 (185mm)	1" NPT	2.57 (65mm)	ECS5

Performance Characteristics

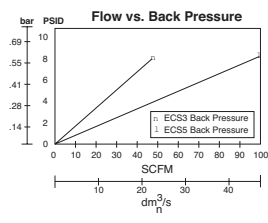
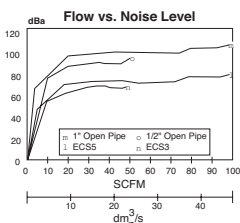

Most popular.



Operating information

Maximum line pressure:	100 PSIG (6.8 bar)
Maximum operating temperature:	125°F (52°C)

Operation

Compressor oils and lubricating oils are exhausted from valves, cylinders and air motors into the ECS. Oil aerosols are "coalesced" into larger droplets and gravity pulls them into the attached drain sump. The sump can then be drained manually or by using a 1/4" ID plastic tube drain. The air flowing into the ECS is also muffled or silenced as it enters the inside of the ECS and passes through the filter media into the atmosphere.

Proven Technology

The ECS units are constructed from the same materials that go into our oil removal coalescing filter elements.

The seamless design insures media uniformity and strength. This proven technology provides high coalescing efficiency with low pressure drop.

The filter media is supported by cylindrical perforated steel retainers both inside and out. These retainers, fully plated for excellent corrosion resistance, give the ECS units high rupture strength in either flow direction. These filters can also be used as high efficiency inlet or bypass filters for vacuum pumps, or breather elements to protect the air above critical process liquids.

ECS3 / ECS5

The ECS solves two problems inherent in compressed air exhaust from valves, cylinders and air motors - oil mist removal and noise abatement.

The ECS will improve your industrial plant environment, thereby improving worker productivity.



For inventory, lead times, and kit lookup, visit www.pdnplu.com

Automatic Electrical Drain Valve – WDV3-G

The WDV3 Electrical Drain is designed to remove condensate from compressors, compressed air dryers and receivers up to any size, type or manufacturer.

Benefits

- Does not air-lock during operation
- Compressed air systems up to any size
- The direct acting valve is serviceable
- Suitable for all types of compressors
- Test (micro-switch) feature
- High time cycle accuracy
- Large (4.5mm) valve orifice

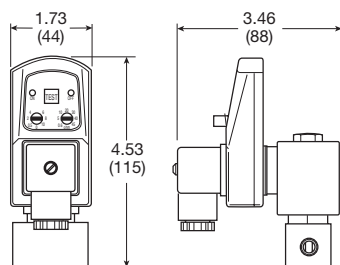

Automatic Electrical Drain Valve

Port Size	Primary Voltage	Weight (Kg)	Model Number
1/4	120VAC	1.8 (0.8 kg)	WDV3-G12BL
1/4	230VAC	1.8 (0.8 kg)	WDV3-G22BL
3/8	120VAC	1.8 (0.8 kg)	WDV3-G13BL
3/8	230VAC	1.8 (0.8 kg)	WDV3-G23BL
1/2	120VAC	1.8 (0.8 kg)	WDV3-G14BL
1/2	230VAC	1.8 (0.8 kg)	WDV3-G24BL
1/2	24VDC	1.8 (0.8 kg)	WDV3-G34BL

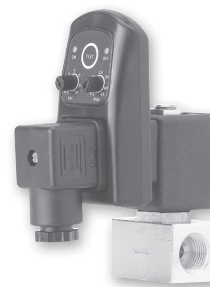

Operating information

Operating pressure:	230 psig (16 bar)
Ambient operating temperature:	34°F to 130°F (1.1°C to 54°C)
Voltages:	115VAC, 230/50-60Hz, 24VDC
Coil insulation:	Class H, 340°F (171.1°C)
Current rating:	4mA maximum
Timer –	
Open time	.5 to 10 sec., adjustable
Cycle time	.5 to 45 min., adjustable

Material specifications

Valve body	Brass / stainless steel
Enclosure (IP65 / NEMA 4)	ABS plastic
Internal parts	Brass / stainless steel
Valve seals	FPM (Fluorocarbon)

Rodless Pneumatic Cylinders

OSP-P Series

P1X Series

GDL Series

2002/P120 Series

P5S Electronic & Reed Sensors

Accessories

Part Number Index

Safety Guide, Offer of Sale



For inventory, lead times, and kit lookup, visit www.pdnplu.com

ED Zero Air Loss Condensate Drains

Zero air loss condensate drains are designed for economical removal of unwanted water, oil emulsions, and other liquids. These drains will only open when liquid is present and will not allow any compressed air to escape from the system.



Operating information

Maximum pressure:	232 psig (16 bar)
Ambient operating temperature:	35°F to 140°F (1.6°C to 60°C)
Voltages optional – NPT	115/50-60Hz, standard
	BSPP ports 230/50-60Hz & 24VDC

Zero Air Loss Condensate Drains

Port Size (NPT)	Compressor Aftercooler (scfm)*	Capacity Refrigeration Dryer (scfm)**	Filter (scfm)	Drain Capacity per Day (gal/liter)	Model Number	Service Kit
1 @ 3/8 (in), 1 @ 3/8 (out)	—	—	424	6 (22.7)	ED3002N115-K	SKED3000N115
1 @ 1/2 (in), 1 @ 3/8 (out)	141	282	1,413	13 (49.2)	ED3004N115-K	SKED3000N115
2 @ 1/2 (in), 1 @ 3/8 (out)	247	494	2,472	23 (87.1)	ED3007N115-K	SKED3000N115
2 @ 1/2 (in), 1 @ 3/8 (out)	1,059	2,119	10,594	100 (378.5)	ED3030N115-K	SKED3000N115
2 @ 1/2 (in), 1 @ 3/8 (out)	3,532	7,063	35,315	330 (1,249.2)	ED3100N115-K	SKED3000N115

* Based on 100 PSI working pressure, air compressor inlet at 77°F (25°C) at 60% RH, air discharge temperature of 95°F (35°C) following the aftercooler, pressure dewpoint of 37°F (2.8°C) after the refrigerated dryer.

** Condensate from aftercooler or refrigerated dryer to be drained upstream – only for residual oil content or small quantities of condensate.

Note: A 6 ft. line cord will be included with each drain.

Where Are Condensate Drains Used?

Compressor with Aftercooler	Receiver Tank	Filter	Air Dryer	Drip Leg
Removes the condensate that is collected after the air cools in the aftercooler	Removes the condensate that is collected when the air cools inside of the receiver tank	Removes the condensate that is collected in the filter bowl	Removes the condensate that is collected in the air dryer	Point-of-use applications: removes the condensate from compressed air pipes in a plant

Dimensions

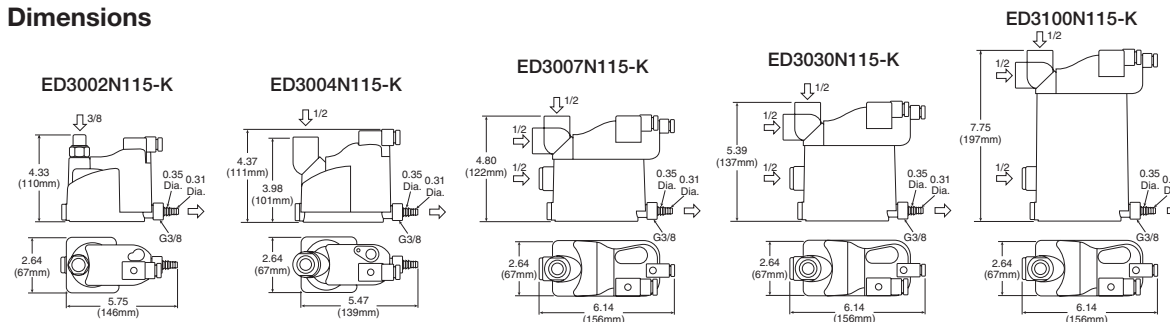

Most popular.



For inventory, lead times, and kit lookup, visit www.pdnplu.com

Drains Cocks

Drain cocks are manufactured in external seats. Hand tightening provides a metal - to - metal seal.

Drain Cock Nomenclature

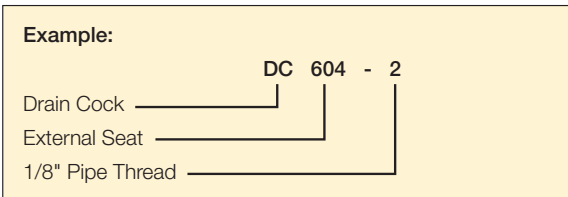

Operating information

Operating pressure: 150 psig (150 bar)
 Temperature ranges:
 Internal seal -65°F to 250°F (-53.9°C to 12.1°C)
 External seal -25°F to 250°F (-31.7°C to 12.1°C)
 Operating fluid: Air, water, gas and certain other fluids
 Note: Lubricant may not be compatible with some fluids, contact factory for special fluid requirements.

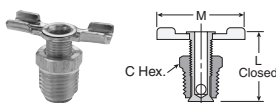

External Seal - Drain Cock DC604

Temperature Range: -25° to 250°F

Part Number	Pipe Thread	C Hex	L	M
DC604-2*	1/8	7/16	.85	1.25
DC604-4	1/4	9/16	1.00	1.38
DC604-6*	3/8	11/16	1.22	1.68

*When assembled handle wings are down facing

Rodless Pneumatic Cylinders

OSP-P Series

P1X Series

GDL Series

2002/P120 Series

P55 Electronic & Reed Sensors

Accessories

Part Number Index

Safety Guide, Offer of Sale



For inventory, lead times, and kit lookup, visit www.pdnplu.com

LV Series

Lockout valves are installed in pneumatic drop legs, or individual pneumatic control lines. In accordance with OSHA procedures, lockout valves are used during maintenance and service procedures of pneumatically (air) operated equipment.

- Used for compliance with OSHA 29 CFR part 1910
- 1/4" to 2" pipe sizes. NPT or BSPP
- Yellow cast aluminum body with red handle
- (NACE MR0175 / ISO 15156)
- Inline or surface mountable
- Built in port for pressure verification to meet ANSI B11 and PMMI B155 requirements
- Fluorocarbon slipper seals for easy shifting, even after long periods of inactivity



Operating information



Operating pressure:	
Compact	15 to 145 PSIG
Standard	15 to 300 PSIG
High flow	15 to 300 PSIG
Operating temperature: 40°F to 175°F	
Operating media: Clean, dry, compressed air (5 micron)	

Material specifications

Description	LV
Body:	Cast aluminum alloy
Handle:	Plastic
Spool:	Aluminum
Seals:	Carboxylated nitrile
Detent spring:	Stainless steel
Grease:	Magnalube G †

† Trademark Magnalube

Compact

	Port In/Out	Port Exhaust	SCFM In/Out	SCFM Exhaust	Wt (lb)	Part Number *
	1/4	3/8	41.8	40.7	0.9	LV2N3B
	3/8	3/8	60.7	60.7	0.9	LV3N3B

Standard

	Port In/Out	Port Exhaust	Scfm In/Out	Scfm Exhaust	Wt (lb)	Part Number *
	3/8	3/4	107.7	81.1	2.0	LV3N6B
	1/2	3/4	161.4	90.9	2.0	LV4N6B
	3/4	3/4	187.7	93.2	2.0	LV6N6B
	3/4	1-1/4	297.7	204	3.2	LV6NAB
	1	1-1/4	375	216	3.2	LV8NAB
	1-1/4	1-1/4	436.4	221	3.2	LVANAB

High Flow

	Port In/Out	Port Exhaust	Scfm In/Out	Scfm Exhaust	Wt (lb)	Part Number *
	1-1/2	2	761.4	1156	8.2	LVBNCB
	2	2	918.2	1186	8.2	LVCNCB

NOTE: Exhaust flow rates calculated using inlet pressure 100 psig (6.7 bar), pressure drop 5 psi (0.34 bar), air temp 68°F (20°C), and 36% relative humidity.
* For BSPP ports, change 4th digit from "N" to "B"

Most popular.



For inventory, lead times, and kit lookup, visit www.pdnplu.com

EZ Series

The EZ series meets all the same standards as the LV series with the added feature of a soft start when opened. There are still 2 detented positions for the handle (push close, pull to open), but when pulled open, an adjustable needle valve controls the rate of pressure build-up. This can protect equipment during start up after maintenance. The EZ is distinguishable from the LV series by the blue dot on the label.

Features

- Combines lockout and soft-start functions in a single unit
- Used in systems for compliance with OSHA standard 29 CFR part 1910
- 3/8 Inch to 1-1/4 inch pipe sizes
- Cv's from 3.7 to 13.7
- 3/4 and 1-1/4 inch: exhaust ports available
- Exhaust port threaded for installation of silencer or line for remote exhausting
- Inline or surface mountable
- Yellow cast aluminum body with red handle. Blue dot on body indicates EZ Series valve
- Fluorocarbon slipper seals for easy shifting, even after long periods of inactivity

Material specifications

Description	
Body:	Cast aluminum alloy
Handle:	Plastic
Spool:	Aluminum
Seals:	Carboxylated nitrile
Detent spring:	Stainless steel
Grease:	Magnalube G [†]

[†] Trademark Magnalube

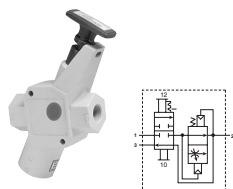

NOTE: Exhaust flow rates calculated using inlet pressure 100 psig (6.7 bar), pressure drop 5 psi (0.34 bar), air temp 68°F (20°C), and 36% relative humidity.
 * For BSPP ports, change 5th digit from "N" to "B"

Most popular.



3/4" Exhaust Shown

Operating information

Operating pressure:	Standard	15 to 300 PSIG
Operating temperature:		40°F to 175°F
Operating media:	Clean, dry, compressed air (5 micron)	

Rodless Pneumatic Cylinders

OSP-P Series

P1X Series

GDL Series

2002/P120 Series

P5S Electronic & Reed Sensors

Accessories

Part Number Index

Safety Guide, Offer of Sale



For inventory, lead times, and kit lookup, visit www.pdnplu.com

Catalog 0961-1
Technical Data

**Rodless Pneumatic Cylinders
 Lockout Valves**

Rodless Pneumatic Cylinders
OSP-P Series
P1X Series
GDL Series
2002/P120 Series
P55 Electronic & Reed Sensors
Accessories
Part Number Index
Safety Guide, Offer of Sale

Applications

Lockout valves are installed in pneumatic drop legs, or individual pneumatic control lines (see Figure 1). In accordance with OSHA procedures, EZ valves are used during maintenance and service procedures of pneumatically (air) operated equipment. Prior to servicing, the red handle is pressed inward, blocking pressure and relieving all downstream air pressure. A padlock is installed through the locking hasp, preventing accidental actuation during the maintenance procedure. Following maintenance, the padlock is removed and the red handle is pulled outward, gradually returning air pressure to the system. (For complete Lockout / Tagout procedures, consult OSHA Standard 29 CFR Part 1910 in U.S. Federal Register/Vol. 54 No. 169, Friday, September 1, 1989 / Page 36644.)

LV Operation

Normal Machine Operation – Valve Open

With the handle pulled outward. Inlet Port 1 is open to outlet Port 2. Exhaust Port 3 is blocked.

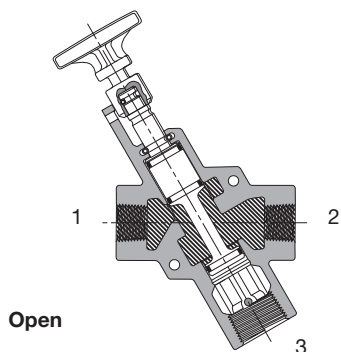

Open

Mounting

Valves can be inline mounted or surface mounted using the two mounting holes provided in the valve body. Mount valves in plain view with the handle oriented for accessibility.

Placement of Lockout Device

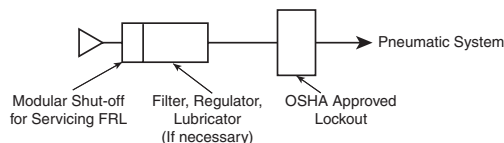
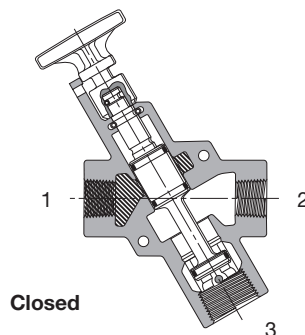

Figure 1.

Lockout Operation – Valve Closed

With the handle pushed inward. Inlet Port 1 is blocked. Outlet Port 2 is open to Exhaust Port 3.



Closed

EZ Operation

Normal Machine Operation – Valve Open

When the red handle is pulled outward, the adjustable needle valve (accessed through the top of the handle) setting determines the rate of pressure buildup. When downstream pressure reaches the full flow described in the specifications below, Inlet Port 1 is open to outlet Port 2. Exhaust Port 3 is blocked.

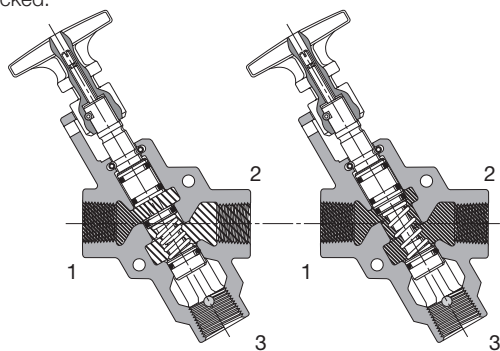

Open
Pressure Building Up

Open
Full Flow

Lockout Operation – Valve Closed

When the red handle is pushed inward, the Inlet Port 1 is blocked. Downstream air is exhausted through Exhaust Port 3.

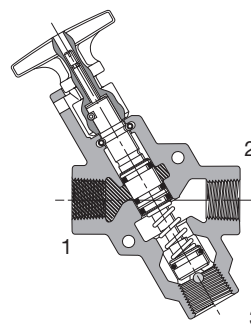

Closed



For inventory, lead times, and kit lookup, visit www.pdnplu.com

Corrosion Resistant Mufflers for Harsh Environments



Port Size	Construction	Threads	Dimensions In. (mm)		Part Number
			Width	Length	
1/4	Stainless steel	Male, NPT	0.56 (14.2)	1.75 (44.5)	5500A2004
1/2	Stainless steel	Male, NPT	0.87 (22.1)	2.75 (69.7)	5500A4004
1	Stainless steel	Male, NPT	1.31 (33.3)	3.87 (98.3)	5500B6004
2	Nickel plated	Male, NPT	2.37 (60.2)	5.50 (139.7)	5500A9004*

* Nickel plated



* NPT ports standard, for BSPT ports, add a "B" after the "S"

Pop-up Pressure Indicator



Brass – Part # **988A30** – Can be used on all LV or EZ series to provide visual verification of line exhaust



Stainless – Part# **1155H30** – Can be used on SS LV series to provide visual verification of line exhaust

Pressure Switch



- Part # **PPS1-2C3-RHM** (DIN 9.4mm connector)
- Part # **PPS1-2C3-RWL** (18" leads)
- Signal verification of line exhaust
- Field adjustable set point

OSP-P Series	GD Series	2002/PI20 Series	P55 Electronic & Reed Sensors	Accessories	Part Number Index	Safety Guide, Offer of Sale
Rodless Pneumatic Cylinders						



For inventory, lead times, and kit lookup, visit www.pdnplu.com

LZ Series, Exhaust Port - Compact, Standard, High Flow

Compact

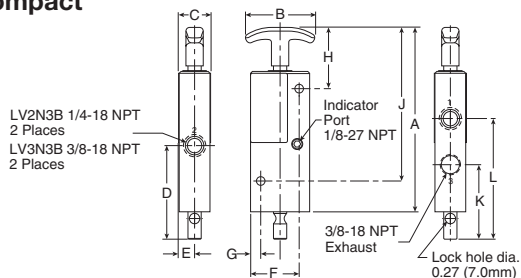

Compact LV Series, 3/8" Exhaust Port Dimensions

A	B	C	D	E	F
6.50 (165)	2.25 (57)	1.05 (27)	3.04 (77)	.51 (13)	1.58 (40)
G	H	J	K	L	
.33 (8)	1.99 (51)	4.99 (127)	2.42 (62)	3.92 (100)	

Inches (mm)

Standard

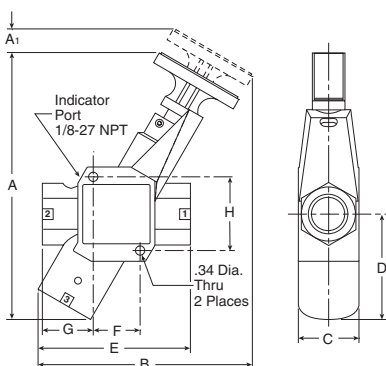

Compact LV Series, 3/4" Exhaust Port Dimensions

A	A1	B	C	D	E
8.32 (211)	0.64 (16)	6.60 (168)	2.00 (51)	3.06 (78)	4.24 (108)
F	G	H			
1.32 (111)	1.56 (40)	2.21 (56)			

Inches (mm)

Compact LV Series, 1-1/4" Exhaust Port Dimensions

A	A1	B	C	D	E
9.91 (252)	0.85 (22)	7.95 (202)	2.25 (57)	3.91 (99)	5.65 (144)
F	G	H			
1.74 (44)	1.89 (48)	2.74 (70)			

Inches (mm)

High Flow

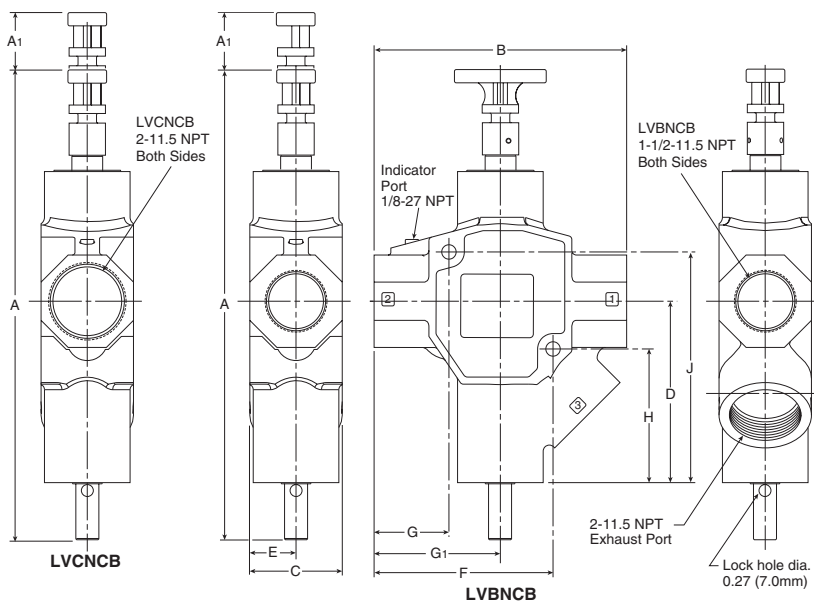

High Flow LV Series, 2" Exhaust Port Dimensions

A	A1	B
14.82 (376)	1.87 (47)	8.20 (208)
C	D	E
3.00 (76)	5.89 (150)	1.50 (38)
F	G	G1
5.81 (148)	2.43 (62)	4.10 (104)
H	J	
4.34 (110)	7.49 (190)	

Inches (mm)

- Rodless Pneumatic Cylinders
- OSP-P Series
- P1X Series
- GDL Series
- 2002/P120 Series
- P55 Electronic & Reed Sensors
- Accessories
- Part Number Index
- Safety Guide, Offer of Sale



For inventory, lead times, and kit lookup, visit www.pdnplu.com

EZ Series, Exhaust Port - Standard Flow

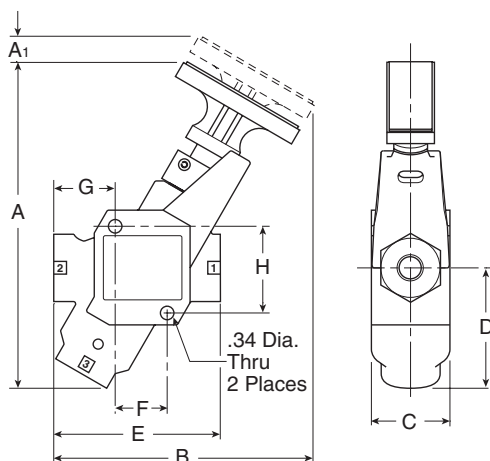

EZ 3/4" Exhaust Port Dimensions

A	A ₁	B	C	D
8.32 (211)	0.64 (16)	6.60 (168)	2.00 (51)	3.06 (78)
E	F	G	H	
4.24 (108)	1.32 (111)	1.56 (40)	2.21 (56)	

Inches (mm)

EZ 1-1/4" Exhaust Port Dimensions

A	A ₁	B	C	D
9.91 (252)	0.85 (22)	7.95 (202)	2.25 (57)	3.91 (99)
E	F	G	H	
5.65 (144)	1.74 (44)	1.89 (48)	2.74 (70)	

Inches (mm)

Rodless Pneumatic Cylinders
OSP-P Series
P1X Series
GDL Series
2002/P120 Series
P5S Electronic & Reed Sensors
Accessories
Part Number Index
Safety Guide, Offer of Sale



For inventory, lead times, and kit lookup, visit www.pdnplu.com

Rodless Pneumatic Cylinders
OSP-P Series
P1X Series
GDL Series
2002/P120 Series
P55 Electronic & Reed Sensors
Accessories
Part Number Index
Safety Guide, Offer of Sale

AirGuard Protection System



CAUTION!



Product Features:

- **Maintenance Friendly**
Repair possible while plant is still operating
- **Economic**
Competitive pricing
- **Complies with EU Standard**
EN 983 - § 5.3.4.3.2
- **Reliable and Tamperproof**
No adjustment necessary
- **Complies with ISO Standard**
4414 - § 5.4.5.11.1
- **Complies with MSHA Regulation**
30CFR 56.13021, 57.13021 and 57.1730
- **Lightweight**
Compact size
- Compatible with all Pneumatic Systems
- Can be used as a Flow Blocker
- **TUV Approval**
No. 01-02-0145
- **EU Registered Utility**
Model No. 0025 73 525
- **Complies with OSHA Regulation Standard**
29CFR 1926.302 (Partial)

Protect your most important assets: your employees and their equipment!

The AirGuard offers simple but efficient protection of a broken compressed-air hose. The air supply is immediately shut off by the AirGuard, should the volume of air exceed a set value. This "value" is factory preset and is set to allow normal air consumption when using air tools.

Should the air consumption exceeds the set value, e.g. the air line is severed, then the internal piston instantly shuts off the main flow. An integral bleed hole allows some air to flow through. This enables the line pressure to automatically reset the AirGuard once the main line break is repaired.

Function:

(P) is the inlet. Air passes the piston (1) and continues through the seat (3). The air flow, passing the piston, is slowed down by means of length wise grooves on the outer side of the piston. If the flow is too high, the air cannot pass the piston quickly enough, and the piston is forced against the spring (2) and towards the seat. The maximum flow is shown in the graph. If the value indicated is exceeded e.g. if the hose suddenly breaks - the air supply is automatically shut of. An integral bleed hole allows some air to flow through. This enables the line pressure to automatically reset the AirGuard once the main line break is repaired.

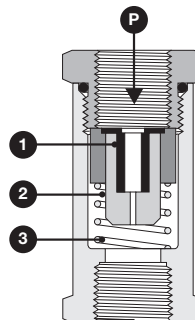

For inventory, lead times, and kit lookup, visit www.pdnplu.com

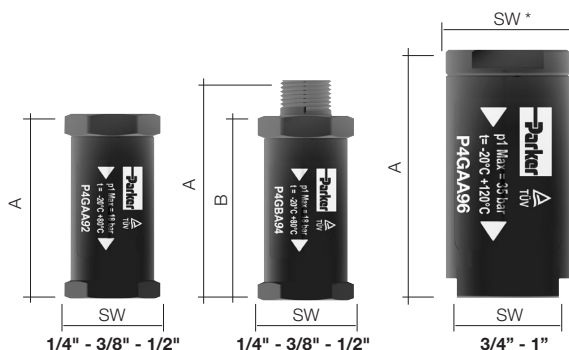

Weight and Dimensions metric (imperial)

Thread Connection	Dimensions inch (mm)			Weight oz. (g)	Max. Inlet Pressure	Temp. Range	Material	P1 Inlet Thread	P2 Outlet Thread	Part Number NPT
	A	B	SW							
1/4"	1.89 (48)	-	.87 (22)	1.06 (30)	255 psig (18 bar)	-4°F to 176°F (-20°C to 80°C)	Housing: Aluminum Piston: Polyacetal	Female	Female	P4GAA92
1/4"	2.28 (58)	49 (1.93)	.87 (22)	1.27 (36)				Male	Female	P4GBA92
3/8"	2.32 (59)	-	1.10 (28)	2.05 (58)				Female	Female	P4GAA93
3/8"	2.80 (71)	59 (2.32)	1.10 (28)	2.19 (62)				Male	Female	P4GBA93
1/2"	2.56 (65)	-	1.22 (31)	2.75 (78)				Female	Female	P4GAA94
1/2"	3.15 (80)	65 (2.56)	1.22 (31)	3.00 (85)				Male	Female	P4GBA94
3/4"	2.99 (76)	-	1.18/1.42* (30/36*)	3.77 (107)	500 psig (35 bar)	-4°F to 248°F (-20°C to 120°C)	Housing: Aluminum Piston: Aluminum	Female	Female	P4GAA96
1"	3.94 (100)	-	1.61/1.97* (41/50*)	10.58 (300)				Female	Female	P4GAA98

How to Select the Optimal Size of an AirGuard

Information based on an inlet pressure of 7 bar (100 psig)

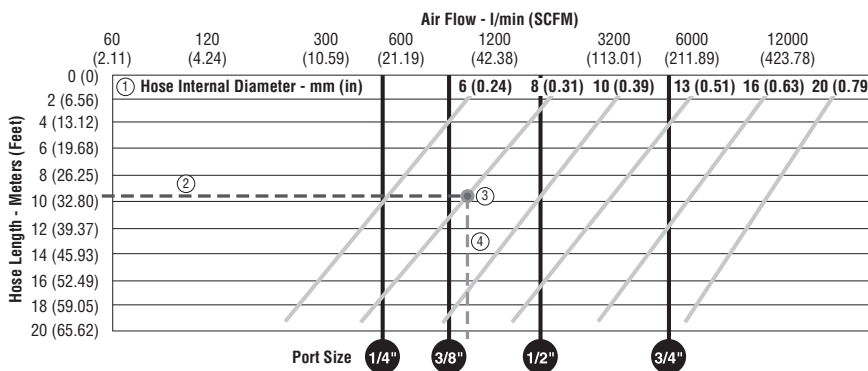

- Determine the internal diameter of the hose, tube or pipe being used ① (see specification Hose-internal Diameter, diagonal line).
- Determine the length of the hose, tube or pipe ② (Hose length in meters).
- Define the intersection of point a and b, and mark a vertical line downwards. ③ - ④ In the example chart (dot ③) and the dashed line ④).
- The next vertical black line, left of the intersection line ④) tells the correct AirGuard size (in inches).
- Important: Every flow value to the right of the respective vertical line (black) would activate the AirGuard in case of a bursting hose, pipe or tube. All AirGuard sizes right of the intersection line ④) are too big and will not close up.
- Example:** Which air fuse should be used for a hose, pipe or tube bearing 8 mm inner diameter and 10 meters of length - follow the 10 meter line ②) to the intersection point (dot ③). Now the next left black line marks the correct size.
- Result:** The correct size in our example is the AirGuard 3/8"



For inventory, lead times, and kit lookup, visit www.pdnplu.com

Rodless Pneumatic Cylinders
OSP-P Series
P1X Series
GDL Series
2002/P120 Series
P55 Electronic & Reed Sensors
Accessories
Part Number Index
Safety Guide, Offer of Sale

OR Series Quick Exhaust & Shuttle Valves

Quick exhaust valves provide rapid exhaust of control air when placed between control valve and actuator. They can also be used as shuttle valves. Diaphragm materials are available in urethane, Nitrile, Fluorocarbon, and PTFE to meet a wide variety of operating conditions.

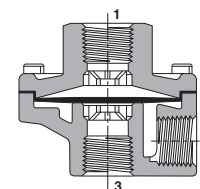

Material Specifications

Body	Die cast aluminum
Static Seals	Nitrile standard with urethane (Others see chart below)
Diaphragm	Standard – Urethane Optional – Fluorocarbon, PTFE, or Nitrile (Depending on size)

Operating information

Operating pressure (Air): 150 PSIG (max), 3 PSIG (min)
200 PSIG (max), 50 PSIG (min) for Model No. OR37TB (PTFE diaphragm)

Operating temperature:*
Urethane: 0°F to 180°F* (-18°C to 80°C)
Nitrile: 0°F to 180°F* (-18°C to 80°C)
Fluorocarbon: 0°F to 400°F* (-18°C to 205°C)
PTFE: 0°F to 500°F* (-18°C to 260°C)

* Ambient temperatures below freezing require moisture-free air. Ambient temperatures below freezing and above 180° require lubricants especially selected for suitability at these temperatures. Pneumatic valves should be used with filtered and lubricated air.

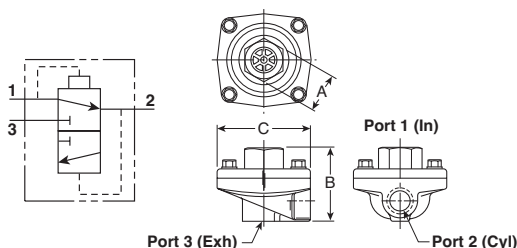

Mounting Bracket Kit – No. 036408100

(Including body screws)
For “OR12” and “OR25” sizes with 7/8” “A” Dimension.

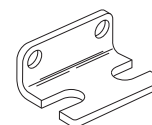

Model Selection, Performance Data and Dimensions

Port	Port		Flow (SCFM †)	Part Number		A	B	C	Service Kit No.
	1	2		3	NPTF				
STANDARD Urethane diaphragms (Nitrile static seals)									
1/4"	1/4"	3/8"	150	OR25NB	ORB25NB	1" Hex	2.06	2.44	033400105
	3/8"	3/8"	240	OR25PB	—	1" Hex	2.06	2.44	033400105
3/8"	3/8"	3/8"	240	OR37B	ORB37B	1" Hex	2.06	2.44	033400105
1/2"	1/2"	1/2"	450	OR50B	ORB50B	1-1/2" Hex	2.88	3.38	034750109
3/4"	3/4"	3/4"	550	OR75B	ORB75B	1-1/2" Hex	2.88	3.38	034750109
Nitrile diaphragms (Nitrile static seals)									
1/8"	1/8"	1/8"	70	OR12B	ORB12B	7/8" Sq.	1.75	1.88	033400105
	1/8"	1/4"	70	OR12NB	ORB12NB	7/8" Sq.	1.75	1.88	033400105
1/4"	1/4"	1/4"	90	OR25B	ORB25B	7/8" Sq.	1.75	1.88	036408000
	1/4"	3/8"	90	OR25NFB	ORB25NFB	1" Hex	2.06	2.44	033408000
3/8"	3/8"	3/8"	240	OR37FB	ORB37FB	1" Hex	2.06	2.44	033408000
3/4"	3/4"	3/4"	550	OR75FB	ORB75FB	1-1/2" Hex	2.88	3.38	034759000
Fluorocarbon diaphragms for extended temperature operation (Fluorocarbon static seals)									
1/8"	1/8"	1/8"	70	OR12VB	ORB12VB	7/8" Sq.	1.75	1.88	036508000
	1/8"	1/4"	70	OR12NVB	ORB12NVB	7/8" Sq.	1.75	1.88	036508000
1/4"	1/4"	1/4"	90	OR25VB	ORB25VB	7/8" Sq.	1.75	1.88	036508000
3/8"	3/8"	3/8"	240	OR37VB	ORB37VB	1" Hex	2.06	2.44	033400319
1/2"	1/2"	1/2"	450	OR50VB	ORB50VB	1-1/2" Hex	2.88	3.38	034750120
3/4"	3/4"	3/4"	550	OR75VB	ORB75VB	1-1/2" Hex	2.88	3.38	034750120
PTFE diaphragms for higher pressure and temperature (Fibre static seals)									
3/8"	3/8"	3/8"	240	OR37TB	ORB37TB	1" Hex	2.06	2.44	033400504

† At 100 PSIG inlet pressure with full pressure drop.

☐ Most popular.



For inventory, lead times, and kit lookup, visit www.pdnplu.com

Shuttle Valves

Shuttle valves determine a single pneumatic output from two separate inputs. If pressure is applied to both ports simultaneously, the valve will select the port with the higher pressure.



Material Specifications

Body	Aluminum
Internal Components	Aluminum
Seals	Nitrile

Operating information

Operating pressure:
 Maximum: 200 PSIG
 Minimum: Differential Pressure 3 PSIG

Operating temperature:* 0°F to 160°F

* Ambient temperatures below freezing require moisture-free air. Ambient temperatures below freezing and above 180° require lubricants especially selected for suitability at these temperatures. Pneumatic valves should be used with filtered and lubricated air.

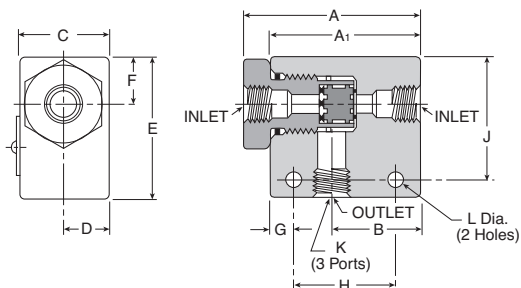

Model Selection and Dimensions

Port Size	Flow (Cv)	Dimensions												Part Number
		A	A1	B	C	D	E	F	G	H	J	K	L	
1/8"	0.32	N/A	1.62	0.81	0.62	0.31	1.00	0.281	0.312	1.00	0.75	1/8 - 27	0.219	N1641001
1/4"	1.65	2.50	2.12	1.25	1.25	0.62	2.00	0.67	0.265	1.25	1.35	1/4 - 18	0.219	N1642003
3/8"	2.02	2.50	2.12	1.25	1.25	0.62	2.00	0.67	0.265	1.25	1.35	3/8 - 16	0.219	N1643003

Most popular.



For inventory, lead times, and kit lookup, visit www.pdnplu.com

Rodless Pneumatic Cylinders
OSP-P Series
P1X Series
GDL Series
2002/P120 Series
P55 Electronic & Reed Sensors
Accessories
Part Number Index
Safety Guide, Offer of Sale

Rodless Pneumatic Cylinders
OSP-P Series
P1X Series
GDL Series
2002/P120 Series
P55 Electronic & Reed Sensors
Accessories
Part Number Index
Safety Guide, Offer of Sale

Typical “Quick Exhaust Valve” Applications

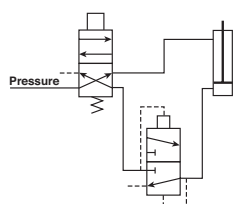

Rapid Retraction – Double Acting Cylinder

In this circuit, air is exhausted through a Quick Exhaust Valve that is **close coupled** to the cap end of the cylinder. Because the Quick Exhaust Valve has a greater exhaust capacity than the four-way Control Valve, increased cylinder speed can be accomplished with a smaller and less expensive control valve.

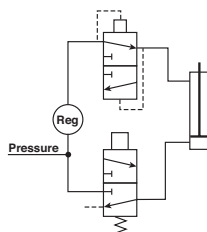

Dual Pressure Actuation of Double Acting Cylinder

This circuit utilizes a Quick Exhaust Valve and a three-way Control Valve to permit rapid extension of the cylinder at a high pressure.

NOTE: Line pressure must be 3 or 4 times greater than rod end pressure. Effective working pressure is the differential between the cap and rod end.

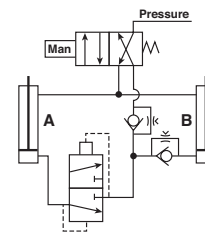

Bi-Directional Control of Two Double Acting Cylinders

This circuit provides maximum control with a minimum of valving. A large four-way Control Valve is not needed to permit the rapid retraction of Cylinder A, as the Quick Exhaust Valve performs this function. The extension of Cylinders A and B and retraction of Cylinder B are controlled by Speed Control Valves.

Typical “Shuttle Valve” Applications

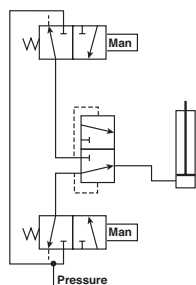

“OR” Circuit

The most common application of the Shuttle Valve is the “OR” Circuit. Here a cylinder or other work device can be actuated by either control valve. The valves can be manually or electrically actuated and located in any position.

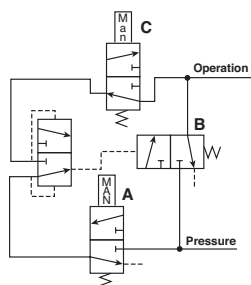

Memory Circuit

This circuit enables continuous operation once initiated. Pressure is delivered to the circuit when Valve A is actuated. This allows pressure to pass through the shuttle valve actuating Valve B. Pressure then flows through Valve B and also the other side of the shuttle valve which holds Valve B open for continuous operation. To unlock the circuit, Valve C must be opened to exhaust the circuit and allow Valve B to return to its normally closed position.

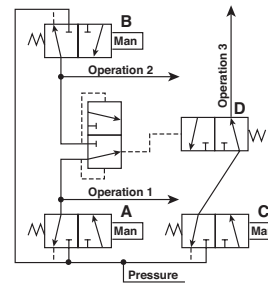

Interlock

This circuit prevents the occurrence of a specific operation while one or another operation takes place. When either Valve A or B is actuated to perform operation 1 or 2, Valve D is shifted to the closed position and prevents operation 3 from occurring.



For inventory, lead times, and kit lookup, visit www.pdnplu.com

Threshold Sensors

The plug-in threshold sensors provide feedback information on pneumatic cylinder status in either pneumatic or electrical outputs. Mounted into the cylinder port, these devices monitor the back pressure of the cylinder's exhaust. When the cylinder's piston stops, the back pressure rapidly drops and the threshold sensor provides the desired output. Ideal for variable stroke applications such as robotics where other sensor type devices such as limit switches are impractical, these devices provide a signal whenever the cylinder stops motion.

The threshold sensor consists of two complementary sub assemblies (1) the banjo fitting and (2) the plug-in sensor element. In all cases, the sensor is easily plugged into the banjo fitting and locked in place with a spring clip. The banjo fitting is designed to accept (piggy backed) other functional fittings such as flow controls or blocking valves. Simply select the sensor based on the type feedback signal that best fits the application.

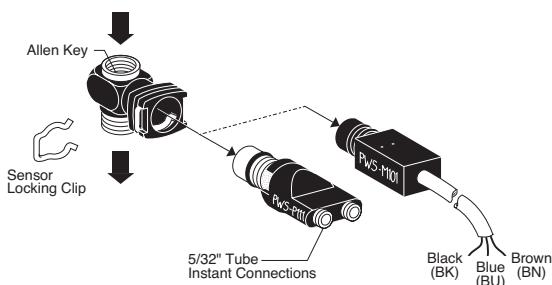

Material specifications

Body	Thermoplastic
Mounting screw	Brass

Banjo Sockets (with Sensor Clip)

Port Size	Wrench	Part Number
10-32	5/16" Hex	PWSB1557
1/8"	3/16" Allen	PWSB1887
1/4"	5/16" Allen	PWSB1997
3/8"	3/8" Allen	PWSB1337
1/2"	1/2" Allen	PWSB1227



Most popular.



Operating information

Operating pressure: 0 to 150 PSIG (0 to 10.3 bar)

Operating temperature:

Operating 5°F to 140°F (-15°C to 60°C)
Storage -40°F to 160°F (-40°C to 70°C)

⚠ Caution: If it is possible that the ambient temperature may fall below freezing, the medium must be moisture free to prevent internal damage or unpredictable behavior.

Mounting

Banjo fittings in 10-32 to 1/2" pipe sizes are designed to be installed directly into actuator ports (up to 5" bore cylinders). The banjo fitting can accommodate other functional fittings and components such as right angle flow control valves or blocking valves. Banjo fittings screw into actuators using an Allen wrench or 5/16" hex head wrench for 10-32 size. Electrical or pneumatic feedback element snaps into place using a locking clip.

Operation

Pneumatic sensors have a continuous pressure signal applied to the sensor device. Electrical sensors have a continuous electrical signal applied to the sensor device. The threshold sensor assembly mounted directly into the cylinder Port provides an output signal S, which can be pneumatic or electrical, when the falling back pressure in the exhausting chamber of the cylinder reaches the operating threshold (approximately 6-9 PSIG). (The device is a normally passing device. The output is only on when there is nearly zero pressure at the cylinder.)

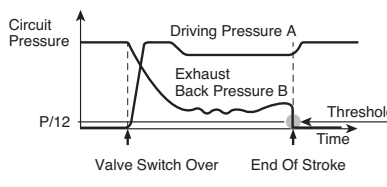

Rodless Pneumatic Cylinders
OSP-P Series
P1X Series
GDL Series
2002/P120 Series
P55 Electronic & Reed Sensors
Accessories
Part Number Index
Safety Guide, Offer of Sale



For inventory, lead times, and kit lookup, visit www.pdnplu.com

Catalog 0961-1 Specifications

Rodless Pneumatic Cylinders Sensing, Threshold Sensors – PWS

Specifications

Maximum Operating Frequency	10 Hz
Pilot Pressure (PWSP111)	>64 PSIG (4.4 bar)
Threshold Pressure	6 to 9 PSIG (.4 to .6 bar)
Output Flow Rate (PWSP111)	3 SCFM at 90 PSIG
Current Rating (PWSM1012) –	5 VA, 250 VAC 5W, 48 VAC
Life Expectancy –	10 million cycles with dry air at 90 PSIG, 68°F, and 1 Hz operating frequency
Voltage Range (PWSM1012) –	12 - 240 VAC 12 - 48 VDC

Air Quality – Standard Shop Air, Lubricated or Dry 40 µm Filtration

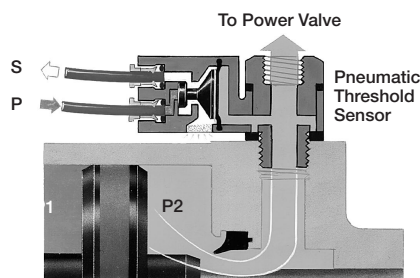
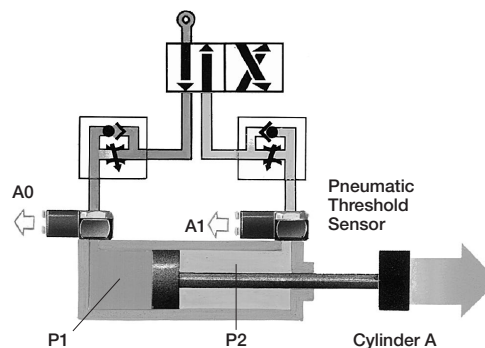
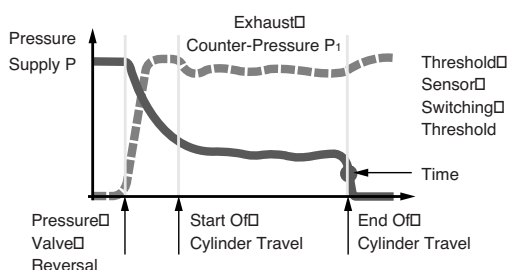

PWS General Characteristics

Permissible Fluids	Air or neutral gas, 50 µm filtration, lubricated or not
Flow	N/A
Mechanical Life	10 Million
Maximum Operating Frequency	10Hz
Maximum Mounting Torque:	
10-32 UNF and M5	88 inch pounds
1/8"	70 inch pounds
1/4"	105 inch pounds
3/8"	265 inch pounds
1/2"	310 inch pounds
Adjustment	N/A
Adjustment Locking	N/A

Piloting and De-Piloting Pressure

Threshold sensors	Pilot with operating pressure of 90 PSI	Depilot with operating pressure of 90 PSI
PWSP111	64 PSI	6 PSI
PWSM1012	15 PSI	9 PSI
PWSE101 and PWSE111	10 PSI	7 PSI

Function	Fluid Power		Universal Description	Electrical	
	Symbol	Symbol		Function	Symbol
Normally Closed (N.C.)			Normally Non-Passing (NNP)	Normally Open (N.O.)	
Normally Open (N.O.)			Normally Passing (NP)	Normally Closed (N.C.)	



For inventory, lead times, and kit lookup, visit www.pdnplu.com

Blocking Valves

	ØA	B	C	K	H	L	Flow*	Part Number
PWBA14/34 	0.86" (22)	0.82" (21)	0.94" (24)	0.53" (13.5)	2.32" (59)	1.54" (39)	14.8	PWBA1468/3468
	0.86" (22)	0.82" (21)	0.94" (24)	0.53" (13.5)	2.09" (53)	1.54" (39)	19.4	PWBA1469/3469 PWBA1489
	1.06" (27)	1.10" (28)	0.94" (24)	0.55" (14)	2.09" (53)	1.98" (50)	45.9	PWBA1483 PWBA1493/3493
	1.22" (31)	1.30" (33)	1.30" (33)	0.94" (24)	2.59" (66)	2.59" (66)	81.2	PWBA1412/3412
PWBA18/38 	0.86" (22)	0.82" (21)	0.94" (24)	0.53" (13.5)	2.32" (59)	1.71" (43.5)	14.8	PWBA1898/3888
	0.86" (22)	0.82" (21)	0.94" (24)	0.53" (13.5)	2.09" (53)	1.71" (43.5)	19.4	PWBA1899/3899
	1.06" (27)	1.10" (28)	0.94" (24)	0.55" (14)	2.09" (53)	2.18" (55)	45.9	PWBA1833/3833
	1.22" (31)	1.30" (33)	1.30" (33)	0.94" (24)	2.59" (66)	2.47" (63)	81.2	PWBA1822/3822
PWBA38 	0.75" (19)	0.87" (22)	0.83" (21)	0.67" (17)	2.20" (56)	1.73" (44)	14.8	PWBA38887
	0.75" (19)	0.87" (22)	0.83" (21)	0.67" (17)	2.20" (56)	1.73" (44)	19.4	PWBA38997
	1.06" (27)	1.18" (30)	1.06" (27)	0.91" (23)	2.64" (67)	1.42" (36)	45.9	PWBA38337
	1.06" (27)	1.18" (30)	1.06" (27)	0.91" (23)	2.64" (67)	1.42" (36)	81.2	PWBA38227

Threshold Sensors

	A	B	C	H	K	L	Part Number
Banjo Socket 	.98 (25)	.43 (11)	5/16" Hex	.79 (20)	.40 (10)	.67 (17)	PWSB1557
	.98 (25)	.63 (16)	3/16" Allen	.71 (18)	.40 (10)	.79 (20)	PWSB1887
	.98 (25)	.83 (21)	5/16" Allen	.71 (18)	.40 (10)	.87 (22)	PWSB1997
	.98 (25)	1.10 (28)	3/8" Allen	.79 (20)	.47 (12)	.98 (25)	PWSB1337
	.98 (25)	1.30 (33)	1/2" Allen	.93 (24)	.55 (14)	1.02 (26)	PWSB1227

	A	B	Part Number
PWSP111 	.87 (22)	.79 (20)	PWSP111
	1.26 (32)	.79 (20)	PWSM1012



For inventory, lead times, and kit lookup, visit www.pdnplu.com

<p>OSP-P Series</p> <p>P1X Series</p> <p>GDL Series</p> <p>2002/P120 Series</p> <p>P55 Electronic & Reed Sensors</p> <p>Accessories</p> <p>Part Number Index</p> <p>Safety Guide, Offer of Sale</p>	<p>Rodless Pneumatic Cylinders</p>
---	------------------------------------

Tank Valves

For tanks, steel barrels, compressors and other pneumatic containers where a dependable automatic air valve is needed. Equipped with standard valve core and sealing cap. Maximum operating pressure is 185 PSIG. Temperature range is -40°F to 220°F.

Rodless Pneumatic Cylinders

OSP-P Series

P1X Series

GDL Series

2002/P120 Series

P55 Electronic & Reed Sensors

Accessories

Part Number Index

Safety Guide, Offer of Sale

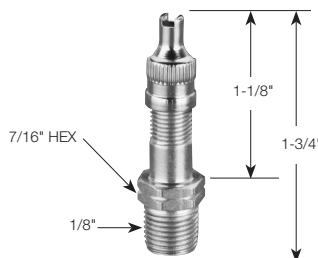
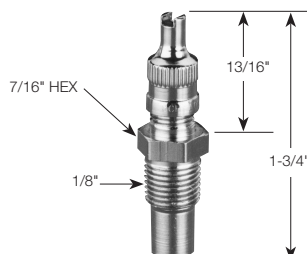
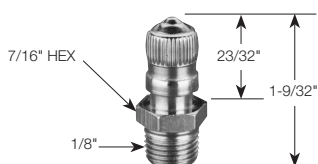

Most popular.



For inventory, lead times, and kit lookup, visit www.pdnplu.com

O.S.H.A. Certification — All safety blow guns conform to the requirements of Compressed Air Standards as currently described in the U.S. Bureau of Labor Standards, paragraph 1910.242, when pressurized at the inlet to a maximum of 100 PSIG. Conform to current O.S.H.A. Directive No. 100-1.

Brass Nozzle Blow Guns

Contoured lever or button control both provide a natural, comfortable grip even when used with gloves. Finger guard and hang-up hook for finger protection and quick safe storage. Die cast zinc body, painted finish.

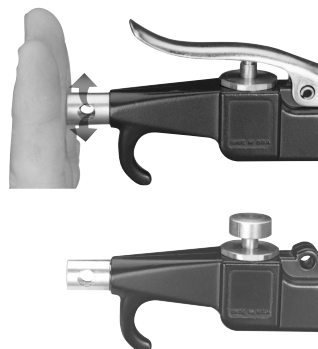

Brass Nozzle Blow Gun

Type	Inlet Port	SCFM Rating*	Part Number
Lever operated	1/4	20	004750010
Button operated	1/4	20	004700010

* Based on 100 PSIG inlet pressure.

Vortec FLO-GAIN Blow Guns

A quiet Vortec FLO-GAIN nozzle is combined with a high performance blow gun. Compressed air attains sonic velocity through an adjustable slot and attaches to the exterior surface of the cone shaped nozzle. Settings are shown on a micrometer dial. Sound level of 80 dBA with 80 PSIG inlet. Finger guard and hang-up hook offers desirable finger protection and quick secure storage. Die cast zinc body, painted finish.



Vortec FLO-GAIN Blow Gun

Type	Inlet Port	SCFM Rating*	Part Number
Lever operated	1/4	70+	004750900
Button operated	1/4	70+	004700900

* Based on 100 PSIG inlet pressure.

Self-Regulating Blow Gun

Designed with integral self-regulating pressure reducing valve for automatic shut-off when nozzle is blocked. Prevents air pressure buildup over 30 PSIG in compliance with U.S. Dept. of Labor standards.

Air shield aids in protecting the operator against blow back of flying chips of dirt. Designed to operate at less than 90 dBA to comply with government regulations. Die cast zinc body, painted finish.



Self-Regulating Blow Gun

Type	Inlet Port	SCFM Rating*	Part Number
Lever operated	1/4	10	004750010

* Based on 100 PSIG inlet pressure.

Most popular.

Performance Data

Inlet Pressure	Blocked Pressure	Sound Level
70 PSIG	17.0 PSIG	79 dBA
100 PSIG	21.0 PSIG	83 dBA
175 PSIG	28.0 PSIG	87 dBA

Rodless Pneumatic Cylinders

OSP-P Series

P1X Series

GDL Series

2002/P120 Series

P55 Electronic & Reed Sensors

Accessories

Part Number Index

Safety Guide, Offer of Sale



For inventory, lead times, and kit lookup, visit www.pdnplu.com

Rodless Pneumatic Cylinders
OSP-P Series
P1X Series
GDL Series
2002/P120 Series
P55 Electronic & Reed Sensors
Accessories
Part Number Index
Safety Guide, Offer of Sale

Brass Nozzle

004707020

General purpose nozzles are supplied as standard on 004700010 and 004750010 blow guns. Conform to the requirements of the Williams Steiger Occupational Safety and Health Act of 1970, paragraph 1910.242 when fitted with blow guns pressurized at the inlet to a maximum of 100 PSIG. Conform to O.S.H.A. Directive 100-1.

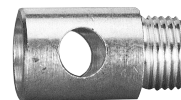

	Part Number
Brass Nozzle	004707020

470 and 475 Series Blow Guns

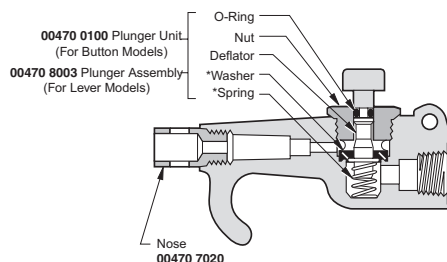





























* Contained in Service Kit No. 00470 0090

Most popular.











For inventory, lead times, and kit lookup, visit www.pdnplu.com

Compact Flow Control Valves	FCC731 Meter Out  Page 203	FCC731 Meter Out - BSPP  Page 203	FCCB731 Bi-Directional Flow Control  Page 203	FCCB731 Bi-Directional Flow Control - BSPP  Page 203	FCKC731 Knobless Meter Out Flow Control  Page 204
	FCKC731 Knobless Flow Control - BSPP  Page 204	FCKCB731 Knobless Bi-Directional Flow Control - BSPP  Page 204	Miniature Flow Control Valves	FCM731 Meter Out Flow Control  Page 205	FCM731 Flow Control - BSPP  Page 205
FCMK731 Knobless Mini Meter Out Flow Control  Page 205	Swivel Outlet Flow Control Valves	FCCS731 Compact Swivel Outlet Flow Control  Page 206		FCMS731 Mini Swivel Outlet Flow Control  Page 206	FCMS731 Miniature Swivel Outlet - BSPP  Page 206
Plug-In Flow Control Valves		FCMSP731 Mini Flow Control  Page 207	FCMSP701 Miniature Flow Control  Page 207	FCCSP731 Compact Flow Control  Page 207	
	In-Line Flow Control Valves	FC832 Flow Control  Page 208	FCB832 Bi-Directional Flow Control  Page 208	FCPM832 Panel Mountable Flow Control  Page 209	FC836 Threaded Flow Control  Page 209
Compact Metal Flow Control Valves		FC705 Push-to-Connect Metal Flow Control  Page 210	FC701 Push-to-Connect Metal Flow Control - BSPP  Page 210	FC708 Threaded Port Meter Out Flow Control  Page 210	FC702 Threaded Port Metal Flow Control - BSPP  Page 210
	Flow Control Check Valves	32PLCK In-Line Check Valve  Page 211	W68PLCK Male Check Valve  Page 211	W68PLCKI Male Check Valve Meter In  Page 211	68PLCK Male Check Valve Meter Out - BSPP  Page 212
VC Check Valve  Page 212					

Rodless Pneumatic Cylinders
OSP-P Series
P1X Series
GDL Series
2002/P120 Series
P55 Electronic & Reed Sensors
Accessories
Part Number Index
Safety Guide, Offer of Sale



For inventory, lead times, and kit lookup, visit www.pdnplu.com

Rodless Pneumatic Cylinders	Blocking Flow Control Valves	FC601 Push-to-Connect Lock Out Valves  Page 213	FC601 Push-to-Connect Lock-Out Valve - BSPP  Page 213	FC602 Threaded Port Lock Out Valves  Page 213	FC608 Threaded Port Lock-Out Valve - BSPP  Page 213	
OSP-P Series	Threshold Sensor	PSBJ731 Pneumatic - 5/32 Pilot  Page 214	PSBJ731 Pneumatic - 4mm Pilot  Page 214	PSPJ731 Pneumatic - 10-32 Pilot  Page 214	PSBJ708 Pneumatic - M5 Pilot  Page 214	PSPE701 Pneumatic / Electric - BSPP  Page 214
P1X Series						
GDL Series						
2002/P120 Series						
P55 Electronic & Reed Sensors						
Accessories						
Part Number Index						
Safety Guide, Offer of Sale						



For inventory, lead times, and kit lookup, visit www.pdnplu.com

Compact Flow Control Valves

Compact flow control regulators ensure excellent performance of flow and are perfectly suited for reduced spaces due to their small size. The sensitivity of the adjustment screw provides very precise air flow control and regulation. A locking nut guarantees stability of adjustment against vibration tampering of the flow setting.



Material Specifications

Body (depending upon the model)	Glass reinforced nylon 6.6 Brass
Gripping Ring	Stainless Steel
Adjustment Screws	Nickel-plated brass
Locking Nut	Nickel-plated brass
Base	Nickel-plated brass

Applicable Tube

Tube O.D.	1/8, 5/32, 1/4, 3/8
Tube O.D. (mm)	4, 6, 8, 10, 12

Operating information

Pressure range:	15 to 145 PSI
Temperature range:	30°F to 160°F
Working fluid:	Compressed air

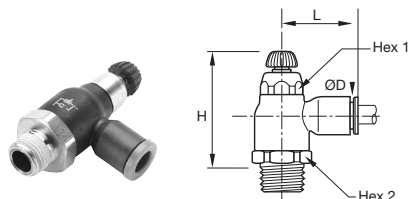

FCC731 Compact Meter Out - NPT

Tube Size (In)	NPT	Hex 1 (In)	Hex 2 (In)	H Open	H Closed	L	Part Number
5/32	1/8	0.63	0.39	1.67	1.44	0.85	FCC731-5/32-2
	1/4	0.63	0.39	1.67	1.44	0.85	FCC731-5/32-4
1/4	1/8	0.63	0.39	1.67	1.44	0.85	FCC731-4-2
	1/4	0.63	0.39	1.67	1.44	0.85	FCC731-4-4
3/8	1/4	0.91	0.67	2.03	1.71	1.22	FCC731-6-4
	3/8	0.91	0.67	2.03	1.71	1.22	FCC731-6-6

FC731 Compact Meter Out - BSPP

Tube Size (mm)	BSPP	Hex 1 (mm)	Hex 2 (mm)	H Open	H Closed	L	Part Number
4	1/8	10	16	38.0	44.0	22.0	FCC731-4M-2G
	1/8	10	16	38.0	44.0	22.0	FCC731-4M-2G
6	1/4	10	16	36.5	42.5	22.0	FCC731-6M-4G
	1/8	14	19	41.5	48.0	28.0	FCC731-8M-2G
8	1/4	14	19	41.5	48.0	28.0	FCC731-8M-4G
	3/8	14	19	41.5	48.0	28.0	FCC731-8M-6G
	1/4	17	23	45.5	53.5	31.5	FCC731-10M-4G
10	3/8	17	23	45.5	54.0	31.5	FCC731-10M-6G
	3/8	17	23	45.5	54.0	35.0	FCC731-12M-6G
12	1/2	17	24	45.5	54.0	35.0	FCC731-12M-8G

Most popular.

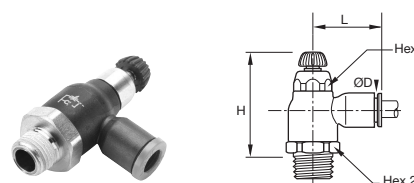

FCCB731 Compact Bi-Directional Flow Control - NPT

Tube Size (In)	NPT	Hex 1 (In)	Hex 2 (In)	H Open	H Closed	L	Part Number
5/32	1/8	0.63	0.39	1.67	1.44	0.85	FCCB731-5/32-2
	1/8	0.63	0.39	1.67	1.44	0.85	FCCB731-4-2
1/4	1/4	0.63	0.39	1.67	1.44	0.85	FCCB731-4-4

FCCB731 Compact Bi-Directional Flow Control - BSPP

Tube Size (mm)BSPP	Hex 1 (mm)	Hex 2 (mm)	H Open	H Closed	L	Part Number	
4	1/8	10	16	38.0	44.0	22.0	FCCB731-4M-2G
	1/8	10	16	38.0	44.0	22.0	FCCB731-6M-2G
6	1/4	10	16	36.5	42.5	22.0	FCCB731-6M-4G
	1/8	14	19	41.5	48.0	28.0	FCCB731-8M-2G
8	1/4	14	19	41.5	48.0	28.0	FCCB731-8M-4G
	3/8	14	19	41.5	48.0	28.0	FCCB731-8M-6G



For inventory, lead times, and kit lookup, visit www.pdnplu.com

Rodless Pneumatic
Cylinders

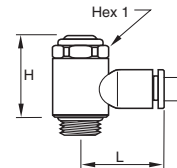
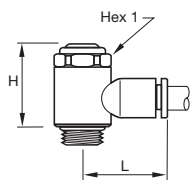

FCKC731 Knobless Meter Out Flow Control - NPT

Tube Size (In)	NPT / UNF	Hex 1 (In)	H	L	Part Number
1/8	10-32	10-32	-	0.69	FCKC731-2-0
	1/8	1/8	13	0.79	FCKC731-2-2
5/32	10-32	10-32	-	0.69	FCKC731-5/32-0
	1/8	1/8	13	0.79	FCKC731-5/32-2
1/4	10-32	10-32	-	0.69	FCKC731-4-0
	1/8	1/8	13	0.79	FCKC731-4-2
5/16	1/4	1/4	17	1.04	FCKC731-4-4
	1/8	1/8	13	0.79	FCKC731-5-2
3/8	1/4	1/4	17	1.04	FCKC731-5-4
	1/4	1/4	17	1.04	FCKC731-6-4
	3/8	3/8	20	1.14	FCKC731-6-6

FCKCB731 Knobless Bi-Directional Flow Control - BSPP

Tube Size (In)	BSPP / M5	Hex 1 (In)	H	L	Part Number
4	M5x0.8	8	17.5	17.0	FCKCB731-4M-M5
	1/8	13	25.0	19.0	FCKCB731-4M-2G
6	M5x0.8	8	17.5	19.0	FCKCB731-6M-M5
	1/8	13	25.0	21.0	FCKCB731-6M-2G
8	1/4	17	26.5	22.0	FCKCB731-6M-4G
	1/8	13	25.0	26.0	FCKCB731-8M-2G
8	1/4	17	26.5	27.0	FCKCB731-8M-4G
	3/8	20	37.5	29.0	FCKCB731-8M-6G

FCKC731 Knobless Meter Out Flow Control - BSPP

Tube Size (mm)	BSPP / M5	Hex 1 (mm)	H	L	Part Number
4	M5x0.8	8.0	17.5	17.0	FCKC731-4M-M5
	1/8	13.0	25.0	19.0	FCKC731-4M-2G
6	M5x0.8	8.0	17.5	19.0	FCKC731-6M-M5
	1/8	13.0	25.0	21.0	FCKC731-6M-2G
8	1/4	17.0	26.5	22.0	FCKC731-6M-4G
	1/8	13.0	25.0	26.0	FCKC731-8M-2G
10	1/4	17.0	26.5	27.0	FCKC731-8M-4G
	3/8	20.0	37.5	29.0	FCKC731-8M-6G
12	1/4	17.0	26.5	29.0	FCKC731-10M-4G
	3/8	20.0	37.5	31.0	FCKC731-10M-6G
12	1/2	23.0	43.0	37.0	FCKC731-10M-8G
	3/8	20.0	37.5	6.8	FCKC731-12M-6G
	1/2	23.0	43.0	37.0	FCKC731-12M-8G

OSP-P
Series

P1X
Series

GDL
Series

2002/P120
Series

P5S Electronic &
Reed Sensors

Accessories

Part Number
Index

Safety Guide,
Offer of Sale



For inventory, lead times, and kit lookup, visit www.pdnplu.com

Miniature Flow Control Valves

The miniature flow control regulator is especially adapted for all very small sized pneumatic applications (micro-pneumatic in particular). They are specifically designed for use with small bore cylinders (pancake / flat cylinders). Miniature flow control regulators are available in meter out, meter in and Bi-Directional versions.



Material Specifications

Body (depending upon the model)	Glass reinforced nylon 6.6 Brass
Gripping Ring	Stainless Steel
Adjustment Screws	Nickel-plated brass
Locking Nut	Nickel-plated brass
Base	Nickel-plated brass

Applicable Tube

Tube O.D.	1/8, 5/32, 1/4
Tube O.D. (mm)	3, 4, 6, 8

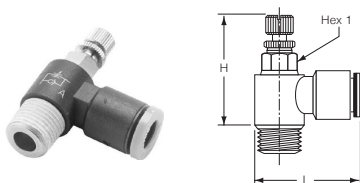

FCM731 Miniature Meter Out Flow Control - NPT

Tube Size (in)	NPT	Hex 1 (mm)	H Open	H Closed	L	Part Number
1/8	10-32	6	1.14	0.91	0.67	FCM731-2-0
	1/8	7	1.41	1.26	0.69	FCM731-2-2
5/32	10-32	6	1.02	0.93	0.67	FCM731-5/32-0
	1/8	7	1.16	1.06	0.71	FCM731-5/32-2
1/4	10-32	6	1.02	0.93	0.73	FCM731-4-0
	1/8	7	1.16	1.06	0.75	FCM731-4-2
	1/4	8	1.28	1.18	0.77	FCM731-4-4

FCM731 Miniature Meter Out Flow Control - BSPP

Tube Size (mm)	BSPP	Hex 1 (mm)	H Closed	H Open	L	Part Number
3	M3x0.5	6	23.5	26.0	17.0	FCM731-3M-M3
	M5x0.8	6	23.5	26.0	17.0	FCM731-3M-M5
4	M3x0.5	6	23.5	26.0	16.5	FCM731-4M-M3
	M5x0.8	6	23.5	26.0	17.0	FCM731-4M-M5
	1/8	7	27.0	29.5	18.0	FCM731-4M-2G
6	M5x0.8	6	23.5	26.0	18.0	FCM731-6M-M5
	1/8	7	27.0	29.5	18.5	FCM731-6M-2G
	1/4	8	30.0	32.5	19.0	FCM731-6M-4G
8	1/8	13	26.5	31.0	26.0	FCM731-8M-2G
	1/4	16	29.0	34.0	27.5	FCM731-8M-4G
	3/8	20	36.0	42.0	29.0	FCM731-8M-6G

Most popular.

Operating information

Pressure range:	15 to 145 PSI
Temperature range:	30°F to 160°F
Working fluid:	Compressed air

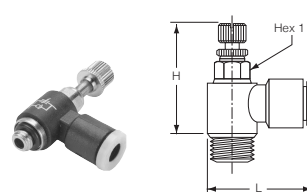

FCMB731 Miniature Bi-Directional Flow Control - BSPP

Tube Size (mm)	BSPP	Hex 1	H Open	H Closed	L	Part Number
4	M5x0.8	6	23.5	26.0	16.5	FCMB731-4M-M5
	1/8	7	27.0	29.5	17.0	FCMB731-4M-2G
6	M5x0.8	6	23.5	26.0	18.0	FCMB731-6M-M5
	1/8	7	27.0	29.5	18.0	FCMB731-6M-2G
6	1/4	8	30.0	32.5	18.5	FCMB731-6M-4G

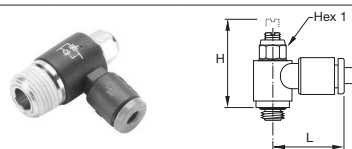

FCMB731 Miniature Bi-Directional Flow Control - BSPP

Tube Size (in)	NPT	Hex 1 mm	H Open	H Closed	L	Part Number
1/8	10-32	6	0.79	0.65	0.65	FCMK731-2-0
	1/8	6	0.85	0.71	0.71	FCMK731-2-2
5/32	10-32	6	0.79	0.65	0.65	FCMK731-5/32-0
	1/8	6	0.85	0.71	0.71	FCMK731-5/32-2
1/4	10-32	6	0.79	0.65	0.65	FCMK731-4-0
	1/8	6	0.85	0.71	0.73	FCMK731-4-2
	1/4	6	0.97	0.83	0.73	FCMK731-4-4

Rodless Pneumatic Cylinders

OSP-P Series

P1X Series

GDL Series

2002/P120 Series

P55 Electronic & Reed Sensors

Accessories

Part Number Index

Safety Guide, Offer of Sale



For inventory, lead times, and kit lookup, visit www.pdnplu.com

Rodless Pneumatic Cylinders

Swivel Outlet Flow Control Valves

Flow control regulators with “swivel outlet” are especially designed to allow a vertical or angled tube exit where access is restricted. The swivel outlet comes with instant push-in connection to ease installation. Flow control regulators with swivel outlet are available in meter out and meter in versions.



Material Specifications

Body	Glass reinforced nylon 6.6
Gripping Ring	Stainless Steel
Adjustment Screws	Nickel-plated brass
Locking Nut	Nickel-plated brass
Base	Nickel-plated brass

Applicable Tube

Tube O.D.	5/32, 1/4, 3/8
Tube O.D. (mm)	4, 6, 8, 10, 12

Operating information

Pressure range:	15 to 145 PSI
Temperature range:	30°F to 160°F
Working fluid:	Compressed air

OSP-P Series

P1X Series

GDL Series

2002/P120 Series

P55 Electronic & Reed Sensors

Accessories

Part Number Index

Safety Guide, Offer of Sale

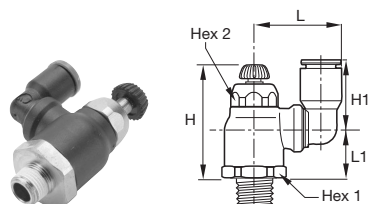

FCCS731 Compact Swivel Outlet Flow Control

Tube Size (in)	NPT	Hex 1 mm	Hex 2 mm	H Closed	H Open	H1	L	L1	Part Number
1/4	19	10	10	1.87	2.09	0.63	0.93	0.65	FCCS731-4-2
	19	14	14	1.79	1.99	0.73	1.00	0.89	FCCS731-4-4
3/8	23	17	17	1.93	2.20	1.04	1.34	0.97	FCCS731-6-4
	23	17	17	1.93	2.20	1.04	1.34	0.97	FCCS731-6-6

FCCS731 Compact Swivel Outlet - BSPP

Tube Size (in)	BSPP	Hex 1 mm	Hex 2 mm	H Closed	H Open	H1	L	L1	Part Number
6	1/8	16	10	38.0	44.0	16.0	23.5	18.0	FCCS731-6M-2G
	1/4	16	10	36.5	42.5	16.0	23.5	16.5	FCCS731-6M-4G
8	1/8	19	14	41.5	48.0	23.0	28.0	19.0	FCCS731-8M-2G
	1/4	19	14	41.5	48.0	23.0	28.0	19.5	FCCS731-8M-4G
	3/8	19	14	41.5	48.0	23.0	28.0	17.5	FCCS731-8M-6G
10	1/4	23	17	45.5	53.5	26.5	35.0	21.0	FCCS731-10M-4G
	3/8	23	17	45.5	54.0	26.5	35.0	21.5	FCCS731-10M-6G
12	3/8	23	17	45.5	54.0	31.0	38.0	21.5	FCCS731-12M-6G
	1/2	23	17	45.5	54.0	31.0	38.0	21.0	FCCS731-12M-8G

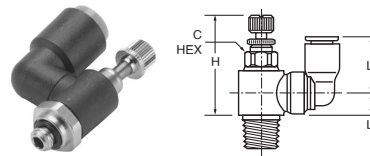

FCMS731 Mini Swivel Outlet Flow Control

Tube Size (in)	NPT	Hex 1 mm	H Closed	H Open	H1	L	L1	Part Number
5/32	10-32	6	0.96	1.08	0.55	0.73	0.26	FCMS731-5/32-0
	1/8	8	1.08	1.20	0.55	0.73	0.33	FCMS731-5/32-2

FCMS731 Miniature Swivel Outlet - BSPP

Tube Size (in)	BSPP	Hex 1 mm	H Closed	H Open	H1	L	L1	Part Number
4	M5x0.8	6	24.5	27.5	14.5	19.5	6.5	FCMS731-4M-M5
	1/8	7	27.5	31.0	14.5	20.0	8.5	FCMS731-4M-2G
6	M5x0.8	6	24.5	27.5	16.0	21.5	6.5	FCMS731-6M-M5
	1/8	7	27.5	31.0	16.0	22.0	8.5	FCMS731-6M-2G



For inventory, lead times, and kit lookup, visit www.pdnplu.com

Plug-In Flow Control Valves

Plug-in flow control regulators can be directly mounted into existing fittings and allow very compact installations. They are particularly suited for mounting in manifolds using cartridges. Their design and function give equal performance to that of flow control regulators with threaded connections.

Material Specifications

Body	Glass reinforced nylon 6.6
Gripping Ring	Stainless Steel
Adjustment Screws	Nickel-plated brass
Locking Nut	Nickel-plated brass
Tailpiece	Nickel-plated brass

Applicable Tube

Tube O.D.	1/8, 5/32, 1/4
Tube O.D. (mm)	4, 6, 8, 10, 12



Operating information

Pressure range:	15 to 145 PSI
Temperature range:	30°F to 160°F
Working fluid:	Compressed air

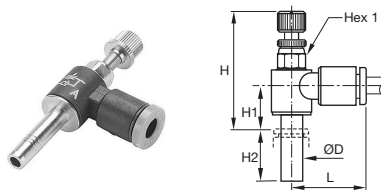

FCMS731 Plug-In Mini Flow Control

Tube Size (In)	Hex 1 mm	H Open	H Closed	H1	H2	L	Part Number
1/8	6	1.04	0.94	0.12	0.59	0.67	FCMS731-2
5/32	6	1.10	1.00	0.37	0.61	0.67	FCMS731-5/32
1/4	7	1.18	1.08	0.12	0.73	0.73	FCMS731-4

FCMS701 - Plug-In Miniature Flow Control

Tube Size (mm)	Hex 1 mm	H Closed	H Open	H1	H2	L	Part Number
4	6	25.5	28.0	9.5	15.5	17.0	FCMS701-4M
6	7	27.5	29.0	10.5	17.0	18.5	FCMS701-6M

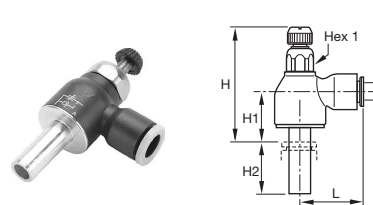

FCCSP731 Plug-In Compact Flow Control

Tube Size (mm)	Hex 1 mm	H Closed	H Open	H1	H2	L	Part Number
6	10	35.0	41.0	14.0	17.0	22.0	FCCSP731-6M
8	14	39.5	46.5	16.0	21.5	28.0	FCCSP731-8M
10	17	43.5	51.5	17.5	24.5	31.5	FCCSP731-10M
12	17	43.0	51.0	17.0	27.0	31.5	FCCSP731-12M

Rodless Pneumatic Cylinders

OSP-P Series

P1X Series

GDL Series

2002/P120 Series

P5S Electronic & Reed Sensors

Accessories

Part Number Index

Safety Guide, Offer of Sale



For inventory, lead times, and kit lookup, visit www.pdnplu.com

In-Line Flow Control Valves

In-line flow controls are unidirectional flow control valves. Intake air flows freely through the flow control; exhaust air is metered out through a specially designed adjustment screw. An arrow on the body of the valve indicates the direction of controlled flow. They can be easily added to existing circuitry. Simply splice it into the cylinder port line.

They can be used individually or they may be stacked together using two joining clips.

Material Specifications

Body	Glass reinforced nylon 6.6
Gripping Ring	Stainless Steel
Adjustment Screws	Nickel-plated brass
Locking Nut	Nickel-plated brass
Tailpiece	Nickel-plated brass

Applicable Tube

Tube O.D.	5/32, 1/4, 5/16, 3/8, 1/2
Tube O.D. (mm)	4, 6, 8, 10, 12

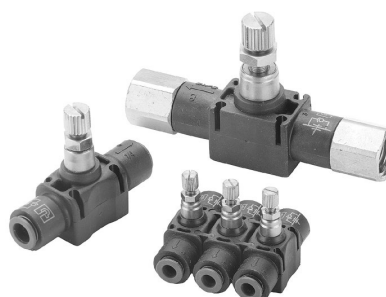

Operating information

Pressure range:	15 to 145 PSI
Temperature range:	30°F to 160°F
Working fluid:	Compressed air

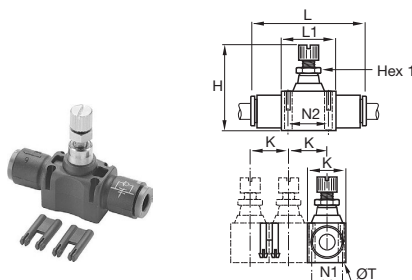

FC832 In-Line Flow Control

Tube Size (In)	Hex 1 mm	H Closed	H Open	K	L	L1	N1	N2	T	Part Number
5/32	5	1.15	1.31	0.47	1.52	0.59	0.31	0.43	0.09	FC832-5/32
1/4	8	1.54	1.74	0.66	2.00	0.90	0.43	0.66	0.12	FC832-4
5/16	11	1.73	1.97	0.73	2.38	1.02	0.49	0.79	0.13	FC832-5
3/8	14	2.03	2.38	0.94	2.87	1.29	0.62	1.01	1.60	FC832-6
1/2	14	2.24	2.63	1.09	3.35	1.37	0.78	1.07	0.16	FC832-8

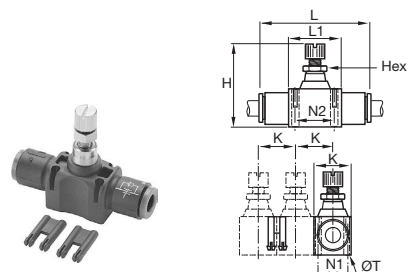

FCB832 In-Line Bi-Directional Flow Control

Tube Size (In)	Hex 1 mm	H Closed	H Open	K	L	L1	N1	N2	T	Part Number
5/32	5	1.15	1.31	0.47	1.52	0.59	0.31	0.43	0.09	FCB832-5/32
1/4	8	1.54	1.74	0.66	2.00	0.90	0.43	0.66	0.12	FCB832-4
5/16	11	1.73	1.97	0.73	2.38	1.02	0.49	0.79	0.13	FCB832-5

FCB832 In-Line Bi-Directional Flow Control

Tube Size (mm)	Hex 1 mm	H Closed	H Open	K	L	L1	N1	N2	T	Part Number
4	5	29.5	33.5	12.0	39.0	15.0	8.0	11.0	2.2	FCB832-4M
6	8	39.5	44.5	17.0	54.0	23.0	11.0	17.0	3.2	FCB832-6M
8	11	44.0	50.0	18.5	60.5	26.0	12.5	20.0	3.2	FCB832-8M

FC832 In-Line Flow Control

Tube Size (mm)	Hex 1 mm	H Closed	H Open	K	L	L1	N1	N2	T	Part Number
4	5	29.5	33.5	12.0	39.0	15.0	8.0	11.0	2.2	FC832-4M
6	8	39.5	44.5	17.0	54.0	23.0	11.0	17.0	3.2	FC832-6M
8	11	44.0	50.0	18.5	60.5	26.0	12.5	20.0	3.2	FC832-8M
10	14	52.0	61.0	24.0	76.0	33.0	16.0	26.0	4.2	FC832-10M
12	14	57.5	67.5	28.0	86.0	35.0	20.0	27.5	4.2	FC832-12M



For inventory, lead times, and kit lookup, visit www.pdnplu.com

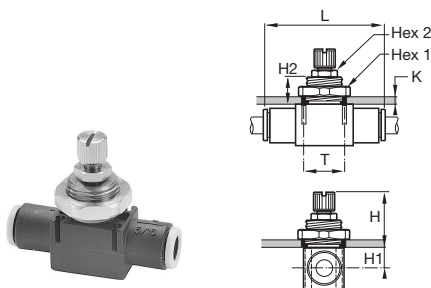

FCPM832 In-Line Panel Mountable Flow Control

Tube Size (mm)	Hex 1 mm	Hex 2 mm	H		K	L	H1	H2	T	Part Number
			Closed	Open						
4	14		21.5	25.5	6.0	39.0	6.5	11.0	10.5	FCPM832-4M
6	19		27.5	32.5	7.0	54.0	7.5	13.5	16.5	FCPM832-6M
8	24	11	28.5	34.5	7.0	60.5	9.0	13.5	18.5	FCPM832-8M
10	30	14	29.5	38.5	7.0	76.0	11.5	13.5	24.5	FCPM832-10M
12	32	14	32.0	42.0	8.0	86.0	12.5	15.5	27.5	FCPM832-12M

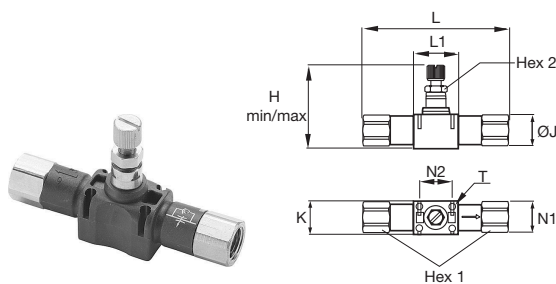

FC836 Threaded In-Line Flow Control

NPT	Hex 1 mm	Hex 2 mm	H		K	L	L1	N1	N2	T	Part Number
			Closed	Open							
1/8	13	8.00	1.56	1.75	0.67	2.70	0.91	0.43	0.67	0.12	FC836-2
1/4	16	11.00	1.73	1.97	0.73	3.27	1.02	0.49	0.79	0.12	FC836-4
3/8	22	14.00	2.05	2.40	0.94	3.82	1.30	0.63	1.02	0.16	FC836-6
1/2	24	14.00	2.26	2.66	1.10	4.76	1.38	0.79	1.08	0.16	FC836-8

FC836 Threaded In-Line Flow Control - BSPP

BSPP	Hex 1 mm	Hex 2 mm	H		K	L	L1	N1	N2	T	Part Number
			Closed	Open							
1/8	13	8	39.5	44.5	17.0	68.5	23.1	11.0	17.0	3.2	FC836-2G
1/4	16	11	44.0	50.0	18.5	83.0	25.9	12.5	20.0	3.2	FC836-4G
3/8	19	14	52.0	61.0	24.0	97.0	33.0	16.0	26.0	4.2	FC836-6G
1/2	24	14	57.5	67.5	28.0	121.0	35.0	20.0	27.5	4.2	FC836-8G

Rodless Pneumatic Cylinders
OSP-P Series
P1X Series
GDL Series
2002/P120 Series
P5S Electronic & Reed Sensors
Accessories
Part Number Index
Safety Guide, Offer of Sale



For inventory, lead times, and kit lookup, visit www.pdnplu.com

Compact Metal Flow Control Valves

Metal flow control regulators are suited for use in severe conditions (temperatures, sparks, abrasion, etc). The screw and locking nut have been designed for easy manipulation, by hand. Adjustment can be made with a screwdriver and locking by use of a wrench.



Material Specifications

Body	Treated brass
Gripping Ring	Stainless Steel
Adjustment Screws	Nickel-plated brass
Locking Nut	Nickel-plated brass
Tailpiece	Nickel-plated brass

Applicable Tube

Tube O.D.	1/8, 5/32, 1/4, 3/8
Tube O.D. (mm)	4, 6, 8, 10, 12, 14

Operating information

Pressure range:	15 to 145 PSI
Temperature range:	30°F to 160°F
Working fluid:	Compressed air

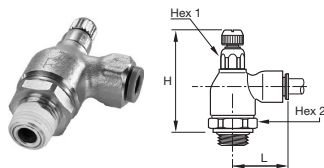

FC705 Push-to-Connect Metal Flow Control

Tube Size (In)	NPT	Hex 1 mm	Hex 2 mm	H Closed	H Open	L	Part Number
5/32	1/8	19	10	1.79	2.01	0.85	FC705-5/32-2
1/4	1/8	19	10	1.79	2.01	0.97	FC705-4-2
	1/4	19	10	1.79	2.01	0.97	FC705-4-4
3/8	1/4	19	14	1.91	2.11	1.14	FC705-6-4
	3/8	25	17	2.15	2.40	1.40	FC705-6-6

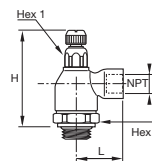

FC708 Threaded Port Meter Out Flow Control

NPT	Hex 1 mm	Hex 2 mm	H Closed	H Open	L	L1	L2	Part Number
1/8	19	10	1.79	2.01	0.89	0.87	1.14	FC708-2
1/4	19	14	1.91	2.11	1.28	0.87	1.28	FC708-4
3/8	25	17	2.15	2.40	1.36	0.91	1.44	FC708-6
1/2	25	17	2.15	2.40	1.50	0.91	1.50	FC708-8

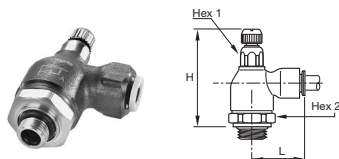

FC701 Push-to-Connect Metal Flow Control - BSPP

Tube Size (mm)	BSPP	Hex 1 mm	Hex 2 mm	H Closed	H Open	L	Part Number
4	1/8	10	19	47.0	53.0	21.0	FC701-4M-2G
	1/8	10	19	47.0	53.0	24.5	FC701-6M-2G
6	1/4	10	19	47.5	53.0	24.5	FC701-6M-4G
	1/8	14	19	50.0	55.0	29.0	FC701-8M-2G
8	1/4	14	19	50.0	56.0	29.0	FC701-8M-4G
	3/8	17	25	56.0	62.0	30.5	FC701-8M-6G
10	1/4	14	19	50.0	56.0	35.0	FC701-10M-4G
	3/8	17	25	56.0	62.0	35.0	FC701-10M-6G
12	3/8	17	25	56.0	62.0	38.0	FC701-12M-6G
	1/2	17	25	55.0	62.0	38.0	FC701-12M-8G
14	1/2	17	25	55.0	62.0	41.0	FC701-14M-8G

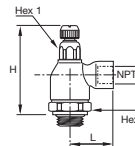

FC702 Threaded Port Meter Out Flow Control - BSPP

BSPP	Hex 1 mm	Hex 2 mm	H Closed	H Open	L	Part Number
1/8	10	19	47.0	52.5	22.5	FC702-2G
1/4	14	19	50.5	55.5	32.0	FC702-4G
3/8	17	25	56.0	62.0	34.5	FC702-6G
1/2	17	25	55.0	62.0	37.5	FC702-8G



For inventory, lead times, and kit lookup, visit www.pdnplu.com

Flow Control Check Valves

These in-line check valves allows air to pass in one direction while blocking flow in the other direction. Their extreme compactness and light weight make them suitable as a safety item in compressed air circuits. The body of the fitting contains an arrow to indicate the direction of flow.

Material Specifications

Body	32PLCK: Nylon/nickel plated brass 68PLCK: Nylon body with nickel-plated brass base VC: Acetal
Gripping Ring	Stainless Steel
O-ring	Nitrile (32PLCK & 68PLCK) EPDM (VC)

Applicable Tube

Tube O.D.	PLCK: 5/32, 1/4, 5/16, 3/8 VC: 1/4, 5/16, 3/8
Tube O.D. (mm)	PLCK: 4, 6, 8, 10, 12



Operating information

Pressure range:	15 to 145 PSI
Temperature range:	34°F to 150°F
Cracking pressure:	PLCK: 7 PSI VC: 1/3 PSI
Working fluid:	Compressed air

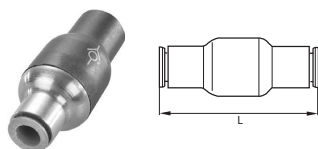

32PLCK In-Line Check Valve - NPT

Tube Size (In)	L	Part Number
5/32	1.52	32PLCK-5/32
1/4	1.61	32PLCK-4
5/16	2.03	32PLCK-5
3/8	2.50	32PLCK-6

32PLCK In-Line Check Valve - BSPP

Tube Size (mm)	L	Part Number
4	38.5	32PLCK-4M
6	41.0	32PLCK-6M
8	51.5	32PLCK-8M
10	63.5	32PLCK-10M
12	66.5	32PLCK-12M

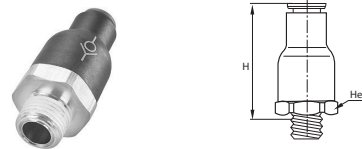

W68PLCK Male Check Valve

Tube Size (In)	NPT/UNF	Hex mm	H	Part Number
5/32	10-32	9	1.26	68PLCK-5/32-0
5/32	1/8	16	1.12	W68PLCK-5/32-2
1/4	1/8	19	1.42	W68PLCK-4-2
1/4	1/4	19	1.42	W68PLCK-4-4
3/8	1/4	23	1.65	W68PLCK-6-4
3/8	3/8	23	1.65	W68PLCK-6-6

W68PLCKI Male Check Valve Meter In

Tube Size (in)	NPT/UNF	Hex mm	H	Part Number
5/32	10-32	9	1.26	68PLCKI-5/32-0
5/32	1/8	16	1.12	W68PLCKI-5/32-2
1/4	1/8	19	1.42	W68PLCKI-4-2
1/4	1/4	19	1.42	W68PLCKI-4-4
3/8	1/4	23	1.65	W68PLCKI-6-4
3/8	3/8	23	1.65	W68PLCKI-6-6

Rodless Pneumatic Cylinders

OSP-P Series

P1X Series

GDL Series

2002/P120 Series

P55 Electronic & Reed Sensors

Accessories

Part Number Index

Safety Guide, Offer of Sale



For inventory, lead times, and kit lookup, visit www.pdnplu.com

Rodless Pneumatic
Cylinders

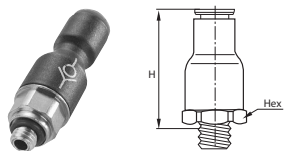

68PLCK Male Check Valve Meter Out - BSPP

Tube Size (mm)	BSPP	Hex 1 mm	H	Part Number
4	M5x0.8	9	32.0	68PLCK-4M-M5
4	1/8	16	28.5	68PLCK-4M-2G
6	1/8	16	30.5	68PLCK-6M-2G
6	1/4	16	30.5	68PLCK-6M-4G
8	1/8	19	36.0	68PLCK-8M-2G
8	1/4	19	36.0	68PLCK-8M-4G

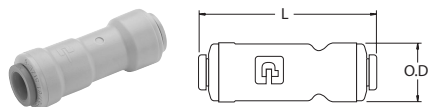

VC - Check Valve

Tube Size (in)	BSPP	Hex 1 mm	Part Number
1/4	2.00	.66	A4VC4-MG
5/16	2.10	.70	A5VC5-MG
3/8	2.15	.80	A6VC6-MG

OSP-P
Series

P1X
Series

GDL
Series

2002/P120
Series

P55 Electronic &
Reed Sensors

Accessories

Part Number
Index

Safety Guide,
Offer of Sale

68PLCKI Male Check Valve Meter In - BSPP

Tube Size (mm)	BSPP	Hex 1 mm	H	Part Number
4	M5x0.8	9	32.0	68PLCKI-4M-M5
6	1/8	16	30.5	68PLCKI-6M-2G
8	1/8	19	36.0	68PLCKI-8M-2G
8	1/4	19	36.0	68PLCKI-8M-4G
10	3/8	23	42.0	68PLCKI-10M-6G
12	3/8	23	42.0	68PLCKI-12M-6G
12	1/2	23	44.0	68PLCKI-12M-8G



For inventory, lead times, and kit lookup, visit www.pdnplu.com

Blocking Flow Control Valves

Blocking valves prevents damage to work and equipment in the event of a loss of pressure. Blocking valves which are mounted in pairs on a cylinder lock the piston by simultaneously cutting off the supply and exhaust. Functional locks are more precise and rapid when blocking valves are located on the cylinder: the volume of air in the pipe work no longer needs to be taken into consideration.



Material Specifications

Body	Treated brass
Gripping Ring	Stainless Steel
Seals, Diaphragm	Nitrile

Applicable Tube

Tube O.D.	1/8, 5/32, 1/4, 3/8
Tube O.D. (mm)	4, 6, 8, 10, 12, 14

Operating information

Pressure range:	15 to 145 PSI
Temperature range:	-4°F to 160°F
Number of cycles:	> 10 million at 68°F and 1 Hz
Leak rate:	< 3.2 CCM
Working fluid:	Compressed air

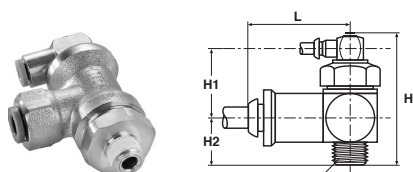

FC601 Push-to-Connect Lockout Valves

Tube Size (In)	NPT	Hex mm	H	H1	H2	L	Part Number
1/4	1/8	21	2.03	1.24	0.79	1.10	FC601-4-2
1/4	1/4	21	2.03	1.24	0.79	1.10	FC601-4-4
3/8	3/8	24	2.19	1.14	1.04	1.38	FC601-6-6
1/2	1/2	24	2.19	1.14	1.04	1.69	FC601-8-8

FC601 Push-to-Connect Lockout Valve - BSPP

Tube Size (mm)	BSPP	Hex 1 mm	H	H1	H2	L	Part Number
6	1/8	21	53	24.5	21.0	28.0	FC601-6M-2G
6	1/4	21	53	24.5	21.0	28.0	FC601-6M-4G
8	1/4	21	53	24.5	21.0	28.0	FC601-8M-4G
8	3/8	24	56	25.0	23.0	34.5	FC601-8M-6G
10	3/8	24	56	25.0	23.0	35.0	FC601-10M-6G
12	1/2	24	56	25.0	23.0	37.5	FC601-12M-8G

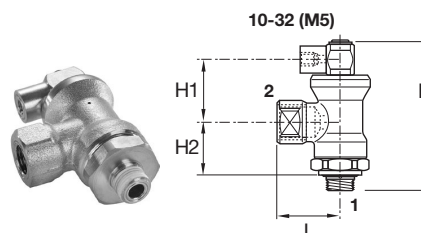

FC602 Threaded Port Lockout Valves

1 NPT	2 NPT	Hex mm	H	H1	H2	L	Part Number
1/4	1/8	21	2.03	1.24	0.79	1.04	FC602-2
1/4	1/4	21	2.03	1.24	0.79	1.04	FC602-4
3/8	3/8	24	2.19	1.14	1.04	1.34	FC602-6
1/2	1/2	24	2.19	1.14	1.04	1.57	FC602-8

FC608 Threaded Port Lockout Valve - BSPP

1 BSPP	2 BSPP	Hex 1 mm	H	H1	H2	L	Part Number
1/8	1/4	21	53	24.5	21.0	28.0	FC608-4G-2G
1/4	1/4	21	53	24.5	21.0	28.0	FC608-4G-4G
3/8	3/8	24	56	25.0	23.0	34.0	FC608-6G-6G
1/2	1/2	24	56	25.0	23.0	41.0	FC608-8G-8G



For inventory, lead times, and kit lookup, visit www.pdnplu.com

Rodless Pneumatic Cylinders
OSP-P Series
P1X Series
GDL Series
2002/P120 Series
P55 Electronic & Reed Sensors
Accessories
Part Number Index
Safety Guide, Offer of Sale

Threshold Sensor

The sensor fitting detects the absence of pressure and translates it to a high pressure pneumatic output. When used to monitor the decaying or exhausting side of a pneumatic cylinder's piston, it emits a positive output. When the cylinder comes to the end of its stroke, wherever that may be, the signal emitted from the sensor can then be used to pilot the next step.



Operating information

	PSBJ, PSPJ	PSPE
Working pressure:	45 to 115 PSI	45 to 115 PSI
Breaking pressure:	8.5 PSI	7 PSI
Working temperature:	5°F to 140°F	–
Response time:	3 Ms	–
Current rating:	–	5A / 250VAC 5W / 48VDC
Reset pressure:	10 PSI	10 PSI
UL listed component		

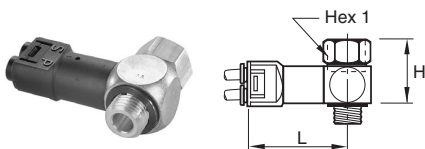

PSBJ731 Pneumatic Threshold Sensor - 5/32 Pilot

NPT / UNF	Hex 1 mm	H	L	Part Number
10-32	5/16	0.62	1.70	PSBJ731-0
1/8	9/16	0.90	1.74	PSBJ731-2
1/4	5/8	1.09	1.81	PSBJ731-4
3/8	7/8	1.13	1.91	PSBJ731-6
1/2	1	1.17	2.05	PSBJ731-8

PSBJ731 Pneumatic Threshold Sensor - 4mm Pilot

BSPP	Hex 1 mm	H	L	Part Number
M5x0.8	8	16	43.5	PSBJ731-M5
1/8	14	23	44.5	PSBJ731-2G
1/4	17	28	46.5	PSBJ731-4G
3/8	22	29	49.0	PSBJ731-6G
1/2	27	30	52.5	PSBJ731-8G

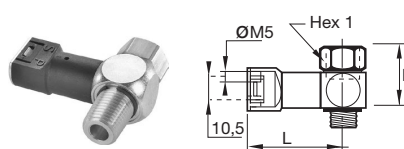

PSPJ731 Pneumatic Threshold Sensor - 10-32 Pilot

NPT	Hex 1 mm	H	L	Part Number
1/8	9/16	0.90	1.58	PSPJ731-2
1/4	5/8	1.09	1.66	PSPJ731-4
3/8	7/8	1.13	1.76	PSPJ731-6

PSBJ708 Pneumatic Threshold Sensor - M5 Pilot

BSPP	Hex 1 mm	H	L	Part Number
1/8	14	23	40.5	PSBJ708-2G
1/4	17	28	42.5	PSBJ708-4G

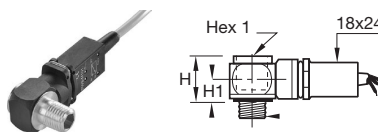

PSPE701 Pneumatic / Electric Threshold Sensor - BSPP

NPT	Hex 1 mm	H	H1	L	Part Number
M5x0.8	8	20	10	49	PSPE701-M5
1/8	6	20	10	52	PSPE701-2G
1/4	8	20	10	54	PSPE701-4G
3/8	10	22	12	57	PSPE701-6G
1/2	12	26	14	58	PSPE701-8G



For inventory, lead times, and kit lookup, visit www.pdnplu.com

Catalog 0961-1
Parker Pneumatic

Rodless Pneumatic Cylinders
Part Number Index

Model No.	Page No.	Model No.	Page No.	Model No.	Page No.	Model No.	Page No.
OR12B.....	194	32PLCK-5.....	213	2002-25-END-CAP-MO.....	155	3085x.....	86
OR12NB.....	194	32PLCK-5/32.....	213	2002-25-END-CAP-V.....	155	3086x.....	86
OR12NVB.....	194	32PLCK-6.....	213	2002-25-END-CAP-V-MO..	155	3250G1000.....	175
OR12VB.....	194	32PLCK-6M.....	213	2002-25-PISTON-B.....	155	3250G1250.....	175
OR25B.....	194	32PLCK-8M.....	213	2002-25-PISTON-MT.....	155	3250G1500.....	175
OR25NB.....	194	32PLCK-10M.....	213	2002-25-PISTON-V.....	155	4010FIL.....	29, 81, 84
OR25NFB.....	194	32PLCK-12M.....	213	2002-32-END-CAP-B.....	155	5010FIL.....	29, 81, 84
OR25PB.....	194	32-UPGRADE-S-B.....	159	2002-32-END-CAP-MO.....	155	5500A2004.....	189
OR25VB.....	194	32-UPGRADE-S-B-2.....	159	2002-32-END-CAP-V.....	155	5500A4004.....	189
OR37B.....	194	32-UPGRADE-S-V.....	159	2002-32-END-CAP-V-MO..	155	5500A9004.....	189
OR37FB.....	194	32-UPGRADE-S-V-2.....	159	2002-32-PISTON-B.....	155	5500B6004.....	189
OR37TB.....	194	40-UPGRADE-S-B.....	159	2002-32-PISTON-MT.....	155	6010FIL.....	29, 81
OR37VB.....	194	40-UPGRADE-S-B-2.....	159	2002-32-PISTON-V.....	155	8010FIL.....	29, 81
OR50B.....	194	40-UPGRADE-S-V.....	159	2002-40-PISTON-B.....	155	8865FIL.....	169
OR50VB.....	194	40-UPGRADE-S-V-2.....	159	2002-40-PISTON-MT.....	155	8866FIL.....	169
OR75B.....	194	50-UPGRADE-S-B.....	159	2002-40-PISTON-V.....	155	8872FIL.....	169
OR75FB.....	194	50-UPGRADE-S-B-2.....	159	2002-50-END-CAP-B.....	155	10750.....	150
OR75VB.....	194	50-UPGRADE-S-V.....	159	2002-50-END-CAP-MO.....	155	10751.....	150
ORB12B.....	194	50-UPGRADE-S-V-2.....	159	2002-50-END-CAP-V.....	155	11052.....	86
ORB12NB.....	194	68PLCK-4M-2G.....	214	2002-50-END-CAP-V-MO..	155	11053.....	86
ORB12NVB.....	194	68PLCK-4M-M5.....	214	2002-50-PISTON-B.....	155	11054.....	86
ORB12VB.....	194	68PLCK-5/32-0.....	213	2002-50-PISTON-MT.....	155	11055.....	86
ORB25B.....	194	68PLCK-6M-2G.....	214	2002-50-PISTON-V.....	155	11056.....	86
ORB25NB.....	194	68PLCK-6M-4G.....	214	2010.....	29, 81	11057.....	86
ORB25NFB.....	194	68PLCK-8M-2G.....	214	2040.....	81	11058.....	86
ORB25VB.....	194	68PLCK-8M-4G.....	214	2060FIL.....	24, 81	11059.....	86
ORB37B.....	194	68PLCKI-4M-M5.....	214	2152-0201.....	155	11060.....	86
ORB37FB.....	194	68PLCKI-5/32-0.....	213	2152-0301.....	155	11061.....	86
ORB37TB.....	194	68PLCKI-6M-2G.....	214	2152-0404.....	155	11062.....	86
ORB37VB.....	194	68PLCKI-8M-2G.....	214	2152-0502.....	155	11063.....	86
ORB50B.....	194	68PLCKI-8M-4G.....	214	2244-0201.....	155	11064.....	86
ORB50VB.....	194	68PLCKI-10M-6G.....	214	2244-0301.....	155	11065.....	86
ORB75B.....	194	68PLCKI-12M-6G.....	214	2244-0451.....	155	11066.....	86
ORB75FB.....	194	68PLCKI-12M-8G.....	214	2244-0501.....	155	11067.....	86
ORB75VB.....	194	0240.....	29	2521-1/2-08.....	85	11068.....	86
25-UPGRADE-S-B.....	159	0250.....	30	2521-1/4-04.....	85	11069.....	86
25-UPGRADE-S-B-2.....	159	00339G3000.....	177	2521-1/8-02.....	85	11070.....	86
25-UPGRADE-S-V.....	159	00339G3001.....	177	2521-3/8-06.....	85	11089FIL.....	86
25-UPGRADE-S-V-2.....	159	988A30.....	189	3010.....	29, 81	11090FIL.....	86
32PLCK-4.....	213	1155H30.....	189	3040FIL.....	81	11091FIL.....	86
32PLCK-4M.....	213	2002-25-END-CAP-B.....	155	3060FIL.....	24, 81	11092FIL.....	86

Rodless Pneumatic Cylinders
OSP-P Series
P1X Series
GDL Series
2002/P120 Series
P55 Electronic & Reed Sensors
Accessories
Part Number Index
Safety Guide, Offer of Sale



For inventory, lead times, and kit lookup, visit www.pdnplu.com

Catalog 0961-1
Parker Pneumatic

Rodless Pneumatic Cylinders
Part Number Index

	Model No.	Page No.	Model No.	Page No.	Model No.	Page No.	Model No.	Page No.
Rodless Pneumatic Cylinders	11093FIL.....	86	20024FIL.....	27	20360FIL.....	81	20971FIL.....	26
	11111x.....	86	20025FIL.....	31	20361FIL.....	81	20976FIL.....	81
	11112x.....	86	20026FIL.....	32	20362FIL.....	25, 81	20977FIL.....	81
	11113x.....	86	20027FIL.....	30, 81	20363FIL.....	81	21107FIL.....	68
	11114x.....	86	20028FIL.....	30, 81	20408FIL.....	29, 81	21108FIL.....	68
	11115x.....	86	20037FIL.....	28	20432FIL.....	31	21109FIL.....	68
	11116.....	86	20039FIL.....	28	20433FIL.....	32	21110FIL.....	68
	11118x.....	86	20092FIL.....	27	20434FIL.....	30, 81	21119FIL.....	83
	11121x.....	86	20093FIL.....	27	20435FIL.....	30, 81	21120FIL.....	83
	11122x.....	86	20094FIL.....	27	20436FIL.....	81	21121FIL.....	83
	11123x.....	86	20095FIL.....	27	20437FIL.....	81	21122FIL.....	83
OSP-P Series	11124x.....	86	20096FIL.....	27	20438FIL.....	31	21125FIL.....	80
	11125x.....	86	20097FIL.....	27	20439FIL.....	32	21126FIL.....	80
	11126x.....	86	20157FIL.....	30, 81	20446FIL.....	28	21127FIL.....	80
	11128x.....	86	20158FIL.....	30, 81	20451FIL.....	30, 81	21128FIL.....	80
P1X Series	11131x.....	86	20161FIL.....	28	20452FIL.....	30, 81	21129FIL.....	80
	11132x.....	86	20162FIL.....	30, 81	20453FIL.....	25, 81	21130FIL.....	82
	11133x.....	86	20163FIL.....	30, 81	20459FIL.....	28	21131FIL.....	82
	11134x.....	86	20166FIL.....	28	20462FIL.....	27	21132FIL.....	82
GDL Series	11135x.....	86	20186FIL.....	31	20463FIL.....	27	21133FIL.....	82
	11136x.....	86	20187FIL.....	32	20464FIL.....	81	21134FIL.....	82
	11138x.....	86	20267FIL.....	31	20465FIL.....	81	21135FIL.....	79
	11141x.....	86	20268FIL.....	32	20466FIL.....	27	21136FIL.....	79
2002/P120 Series	11142x.....	86	20311FIL.....	79, 81	20467FIL.....	27	21137FIL.....	79
	11143x.....	86	20312FIL.....	81	20477FIL.....	27	21138FIL.....	79
	11144x.....	86	20313FIL.....	79, 81	20478FIL.....	27	21139FIL.....	79
	11145x.....	86	20314FIL.....	81	20480FIL.....	30, 81	21140FIL.....	79
P55 Electronic & Reed Sensors	11146x.....	86	20338FIL.....	81, 84	20482FIL.....	30, 81	21141FIL.....	79
	11148x.....	86	20339FIL.....	24, 81	20490FIL.....	28	21142FIL.....	82
	11822FIL.....	86	20340FIL.....	81, 84	20806FIL.....	22	21143FIL.....	82
	11823FIL.....	86	20349FIL.....	81, 84	20807FIL.....	22	21144FIL.....	82
Accessories	11824FIL.....	86	20350FIL.....	24, 81, 84	20808FIL.....	22	21145FIL.....	82
	11825FIL.....	86	20351FIL.....	81	20809FIL.....	22	21146FIL.....	82
	11826FIL.....	86	20352FIL.....	81	20810FIL.....	22	21148FIL.....	82
	11827FIL.....	86	20353FIL.....	25, 81	20811FIL.....	22	21149FIL.....	82
Part Number Index	13039FIL.....	85	20354FIL.....	81	20819FIL.....	25, 81	21150FIL.....	82
	20005FIL.....	27	20355FIL.....	81	20821FIL.....	24, 81	21151FIL.....	82
	20006FIL.....	31	20356FIL.....	25, 81	20822FIL.....	24, 81	21158FIL.....	73
	20007FIL.....	32	20357FIL.....	81	20849FIL.....	33	21159FIL.....	73
Safety Guide, Offer of Sale	20008FIL.....	30, 81	20358FIL.....	81	20850FIL.....	33	21186FIL.....	67
	20009FIL.....	30, 81	20359FIL.....	25, 81	20851FIL.....	33	21187FIL.....	67



For inventory, lead times, and kit lookup, visit www.pdnplu.com

Model No.	Page No.	Model No.	Page No.	Model No.	Page No.	Model No.	Page No.
21188FIL.....	67	87757A.....	117	033400105.....	194	DC604-2.....	185
21189FIL.....	67	109556.....	106	033400319.....	194	DC604-4.....	185
21196FIL.....	61	109559.....	106	033400504.....	194	DC604-6.....	185
21197FIL.....	61	109560.....	106	033408000.....	194	ECS3.....	182
21198FIL.....	61	109561.....	106	034750109.....	194	ECS5.....	182
21199FIL.....	61	109562.....	106	034750120.....	194	ED3002N115-K.....	184
21200FIL.....	61	003371000.....	172, 173	034759000.....	194	ED3004N115-K.....	184
21201FIL.....	61, 67	003371001.....	172, 173	036408000.....	194	ED3007N115-K.....	184
21202FIL.....	61, 67, 73	003371002.....	172, 173	036508000.....	194	ED3030N115-K.....	184
21203FIL.....	61, 67, 73	003371003.....	172, 173	045020002.....	178	ED3100N115-K.....	184
21204FIL.....	61, 67, 73	003371004.....	172, 173	045040004.....	178	EM12.....	178
21205FIL.....	61, 67, 73	003378000.....	172, 173	045060060.....	178	EM25.....	178
21210FIL.....	89	003378001.....	172, 173	045080080.....	178	EM37.....	178
21211FIL.....	89	003378002.....	172, 173	045120012.....	178	EM50.....	178
21213FIL.....	89	003378003.....	172, 173	045160016.....	178	EM75.....	178
21214FIL.....	89	003378004.....	172, 173	047020002.....	179	EM100.....	178
21215FIL.....	89	003393000.....	177	047040004.....	179	EM125.....	178
21216FIL.....	89	003393001.....	177	047060006.....	179	EM150.....	178
21217FIL.....	89	003393002.....	177	047080008.....	179	EMM5.....	178
21218FIL.....	89	003393003.....	177	047120012.....	179	ES12MC.....	179
21235FIL.....	89	003393004.....	177	047160016.....	179	ES25MC.....	179, 189
21240x.....	89	004700010.....	201	047200020.....	179	ES37MC.....	179, 189
21241x.....	89	004700900.....	201	047240024.....	179	ES50MC.....	179, 189
21257FIL.....	73	004707020.....	202	067390000.....	200, 202	ES75MC.....	179, 189
21260FIL.....	73	004750010.....	201	091660060.....	200	ES100MC.....	179, 189
21290FIL.....	67	004750900.....	201	9126344341.....	170	ES125MC.....	179, 189
21342BFIL.....	76	006450060.....	200	9126344342.....	170	ES150MC.....	179, 189
21342LFIL.....	76	032500119.....	174	9126344345.....	170	ES200MC.....	189
21342RFIL.....	76	032500219.....	174	9126344346.....	170	ESB12MC.....	179
21343FIL.....	76	032500319.....	174	A4VC4-MG.....	214	ESB25MC.....	179
21344FIL.....	76	032500419.....	174	A5VC5-MG.....	214	ESB37MC.....	179
21346FIL.....	76	032500519.....	174	A6VC6-MG.....	214	ESB50MC.....	179
63504A.....	117	032510125.....	176	AS-5.....	180	ESB75MC.....	179
63505A.....	117	032510250.....	176	AS-6.....	180	ESB100MC.....	179
63506A.....	117	032510375.....	176	AS-8.....	180	ESB125MC.....	179
63507A.....	117	032510500.....	176	AS-10.....	180	ESB150MC.....	179
87752A.....	117	032511215.....	176	AS-15.....	180	EZ0ANBA.....	187
87753A.....	117	032511225.....	176	ASN-6.....	180	EZ03NB6.....	187
87754A.....	117	032512525.....	176	ASN-8.....	180	EZ04NB6.....	187
87755A.....	117	032512538.....	176	ASN-10.....	180	EZ06NB6.....	187
87756A.....	117	032513838.....	176	ASN-15.....	180	EZ06NBA.....	187

Rodless Pneumatic Cylinders
OSP-P Series
P1X Series
GDL Series
2002/P120 Series
P5S Electronic & Reed Sensors
Accessories
Part Number Index
Safety Guide, Offer of Sale



For inventory, lead times, and kit lookup, visit www.pdnplu.com

Catalog 0961-1
Parker Pneumatic

Rodless Pneumatic Cylinders
Part Number Index

	Model No.	Page No.	Model No.	Page No.	Model No.	Page No.	Model No.	Page No.
Rodless Pneumatic Cylinders	EZ08NBA.....	187	FC708-6.....	212	FCC731-12M-8G.....	205	FCKC731-6M-M5.....	206
	FC601-4-2.....	215	FC708-8.....	212	FCCB731-4-2.....	205	FCKC731-8M-2G.....	206
	FC601-4-4.....	215	FC832-4.....	210	FCCB731-4M-2G.....	205	FCKC731-8M-4G.....	206
	FC601-6-6.....	215	FC832-4M.....	210	FCCB731-5/32-2.....	205	FCKC731-8M-6G.....	206
	FC601-6M-2G.....	215	FC832-5.....	210	FCCB731-6M-2G.....	205	FCKC731-10M-4G.....	206
	FC601-6M-4G.....	215	FC832-5/32.....	210	FCCB731-6M-4G.....	205	FCKC731-10M-6G.....	206
	FC601-8-8.....	215	FC832-6.....	210	FCCB731-8M-2G.....	205	FCKC731-10M-8G.....	206
	FC601-8M-4G.....	215	FC832-6M.....	210	FCCB731-8M-4G.....	205	FCKC731-12M-6G.....	206
	FC601-8M-6G.....	215	FC832-8.....	210	FCCB731-8M-6G.....	205	FCKC731-12M-8G.....	206
	FC601-10M-6G.....	215	FC832-8M.....	210	FCCS731-4-2.....	208	FCKCB731-4M-2G.....	206
OSP-P Series	FC601-12M-8G.....	215	FC832-10M.....	210	FCCS731-4-4.....	208	FCKCB731-4M-M5.....	206
	FC602-2.....	215	FC832-12M.....	210	FCCS731-6-4.....	208	FCKCB731-6M-2G.....	206
	FC602-4.....	215	FC836-2.....	211	FCCS731-6-6.....	208	FCKCB731-6M-4G.....	206
	FC602-6.....	215	FC836-2G.....	211	FCCS731-6M-2G.....	208	FCKCB731-6M-M5.....	206
P1X Series	FC602-8.....	215	FC836-4.....	211	FCCS731-6M-4G.....	208	FCKCB731-8M-2G.....	206
	FC608-4G-2G.....	215	FC836-4G.....	211	FCCS731-8M-2G.....	208	FCKCB731-8M-4G.....	206
	FC608-4G-4G.....	215	FC836-6.....	211	FCCS731-8M-4G.....	208	FCKCB731-8M-6G.....	206
	FC608-6G-6G.....	215	FC836-6G.....	211	FCCS731-8M-6G.....	208	FCM731-2-0.....	207
GDL Series	FC608-8G-8G.....	215	FC836-8.....	211	FCCS731-10M-4G.....	208	FCM731-2-2.....	207
	FC701-4M-2G.....	212	FC836-8G.....	211	FCCS731-10M-6G.....	208	FCM731-3M-M3.....	207
	FC701-6M-2G.....	212	FCB832-4.....	210	FCCS731-12M-6G.....	208	FCM731-3M-M5.....	207
	FC701-6M-4G.....	212	FCB832-4M.....	210	FCCS731-12M-8G.....	208	FCM731-4-0.....	207
2002/P120 Series	FC701-8M-2G.....	212	FCB832-5.....	210	FCCSP731-6M.....	209	FCM731-4-2.....	207
	FC701-8M-4G.....	212	FCB832-5/32.....	210	FCCSP731-8M.....	209	FCM731-4-4.....	207
	FC701-8M-6G.....	212	FCB832-6M.....	210	FCCSP731-10M.....	209	FCM731-4M-2G.....	207
	FC701-10M-4G.....	212	FCB832-8M.....	210	FCCSP731-12M.....	209	FCM731-4M-M3.....	207
P55 Electronic & Reed Sensors	FC701-10M-6G.....	212	FCC731-4-2.....	205	FCKC731-2-0.....	206	FCM731-4M-M5.....	207
	FC701-12M-6G.....	212	FCC731-4-4.....	205	FCKC731-2-2.....	206	FCM731-5/32-0.....	207
	FC701-12M-8G.....	212	FCC731-4M-2G.....	205	FCKC731-4-0.....	206	FCM731-5/32-2.....	207
	FC701-14M-8G.....	212	FCC731-5/32-2.....	205	FCKC731-4-2.....	206	FCM731-6M-2G.....	207
Accessories	FC702-2G.....	212	FCC731-5/32-4.....	205	FCKC731-4-4.....	206	FCM731-6M-4G.....	207
	FC702-4G.....	212	FCC731-6-4.....	205	FCKC731-4M-2G.....	206	FCM731-6M-M5.....	207
	FC702-6G.....	212	FCC731-6-6.....	205	FCKC731-4M-M5.....	206	FCM731-8M-2G.....	207
	FC702-8G.....	212	FCC731-6M-2G.....	205	FCKC731-5-2.....	206	FCM731-8M-4G.....	207
Part Number Index	FC705-4-2.....	212	FCC731-6M-4G.....	205	FCKC731-5-4.....	206	FCM731-8M-6G.....	207
	FC705-4-4.....	212	FCC731-8M-2G.....	205	FCKC731-5/32-0.....	206	FCMB731-4M-2G.....	207
	FC705-5/32-2.....	212	FCC731-8M-4G.....	205	FCKC731-5/32-2.....	206	FCMB731-4M-M5.....	207
	FC705-6-4.....	212	FCC731-8M-6G.....	205	FCKC731-6-4.....	206	FCMB731-6M-2G.....	207
Safety Guide, Offer of Sale	FC705-6-6.....	212	FCC731-10M-4G.....	205	FCKC731-6-6.....	206	FCMB731-6M-4G.....	207
	FC708-2.....	212	FCC731-10M-6G.....	205	FCKC731-6M-2G.....	206	FCMB731-6M-M5.....	207
	FC708-4.....	212	FCC731-12M-6G.....	205	FCKC731-6M-4G.....	206	FCMK731-2-0.....	207



For inventory, lead times, and kit lookup, visit www.pdnplu.com

Model No.	Page No.	Model No.	Page No.	Model No.	Page No.	Model No.	Page No.
FCMK731-2-2	207	FDC45HP-00010000	117	L080180025	103	N1643003	195
FCMK731-4-0	207	FDC45HP-00020000	117	L080180032	103	OSP-P Active Brake	22
FCMK731-4-2	207	FDC45-WIPER-KIT	118	L080180040	103	OSP-P Bi-Parting	38
FCMK731-4-4	207	GDL	112	L080180050	103	OSP-P Clean Room	34
FCMK731-5/32-0	207	HD25	69	L080180063	103	OSP-P HD	69
FCMK731-5/32-2	207	HD32	69	L080190016	103	OSP-P KF	62
FCMS731-4M-2G	208	HD40	69	L080190020	103	OSP-P Linear Guides	41
FCMS731-4M-M5	208	HD50	69	L080190025	103	OSP-P POWERSLIDE	48
FCMS731-5/32-0	208	KC3102	170	L080190032	103	OSP-P PROLINE	52
FCMS731-5/32-2	208	KC3104	170	LV2N3B	186	OSP-P Series	2, 4, 6, 8, 9
FCMS731-6M-2G	208	KF16	62	LV3N3B	186	OSP-P SLIDELINE	43
FCMS731-6M-M5	208	KF25	62	LV3N6B	186	OSP-P Standard	10
FCMSP701-4M	209	KF32	62	LV4N6B	186	OSP-P STARLINE	57
FCMSP701-6M	209	KF40	62	LV6N6B	186	P1X	92
FCMSP731-2	209	KF50	62	LV6NAB	186	P4GAA92	193
FCMSP731-4	209	KL3045	150	LV8NAB	186	P4GAA93	193
FCMSP731-5/32	209	KL3048	150	LVANAB	186	P4GAA94	193
FCPM832-4M	211	KL3300	151	LVBNCB	186	P4GAA96	193
FCPM832-6M	211	KL3312	151	LVCNCB	186	P4GAA98	193
FCPM832-8M	211	L08016M020	104	MB-PL25	55	P4GBA92	193
FCPM832-10M	211	L08016M025	104	MB-PL32	55	P4GBA93	193
FCPM832-12M	211	L08016M032	104	MB-PL40	55	P4GBA94	193
FDC12HP	116	L08016M040	104	MB-PL50	55	P6M-PAB1	181
FDC12-WIPER-KIT	118	L08016M050	104	MB-SL25	46	P6M-PAB2	181
FDC15HP	116	L08016M063	104	MB-SL32	46	P6M-PAB3	181
FDC15HP-00010000	117	L078930016	104	MB-SL40	46	P6M-PAB4	181
FDC15HP-00020000	117	L079020016	94	MB-SL50	46	P6M-PAB6	181
FDC15-WIPER-KIT	118	L079020020	94	MB-SL63	46	P6M-PAB8	181
FDC20HP	116	L080100025	94	MB-SL80	46	P6M-PAC5	181
FDC20HP-00010000	117	L080100032	94	MC25M	61, 67	P8CS0803J	170
FDC20HP-00020000	117	L080100040	94	MC25MH	61, 67	P8CS1204J	170
FDC20-WIPER-KIT	118	L080100050	94	MC75M-1	61, 67, 73	P8SAGACHA	168
FDC25HP	116	L080100063	94	MC75M-2	61, 67, 73	P8SAGACHB	168
FDC25HP-00010000	117	L080160020	104	MC150M-B	61, 67, 73	P8SAGACHD	168
FDC25HP-00020000	117	L080160025	104	MC150MH-B	61, 67, 73	P8SAGACHF	168
FDC25-WIPER-KIT	118	L080160032	104	MC225M	61, 67, 73	P8SAGACHH	168
FDC35HP	116	L080160040	104	MC225MH	61, 67, 73	P8SAGDFMXW	165
FDC35HP-00010000	117	L080160050	104	MC600M	61, 67, 73	P8SAGDFTXW	165
FDC35HP-00020000	117	L080160063	104	MC600MH	61, 67, 73, 106	P8SAGECNX	165
FDC35-WIPER-KIT	118	L080180016	103	N1641001	195	P8SAGEFRX	165
FDC45HP	116	L080180020	103	N1642003	195	P8SAGEFRX1	165

Rodless Pneumatic Cylinders
OSP-P Series
P1X Series
GDL Series
2002/P120 Series
P55 Electronic & Reed Sensors
Accessories
Part Number Index
Safety Guide, Offer of Sale



For inventory, lead times, and kit lookup, visit www.pdnplu.com

Catalog 0961-1
Parker Pneumatic

Rodless Pneumatic Cylinders
Part Number Index

	Model No.	Page No.	Model No.	Page No.	Model No.	Page No.	Model No.	Page No.
Rodless Pneumatic Cylinders	P8SAGHMHA.....	168	PS 16/25.....	48	PWBA1899/3899.....	199	SP124-B-S.....	159
	P8SAGHMHB.....	168	PS 25/25.....	48	PWBA38227.....	199	SP124-V-L.....	159
	P8SAGHMHD.....	168	PS 25/35.....	48	PWBA38337.....	199	SP124-V-S.....	159
	P8SAGHMHF.....	168	PS 25/44.....	48	PWBA38887.....	199	SP126-B-L.....	159
	P8SAGHMHH.....	168	PS 32/35.....	48	PWBA38997.....	199	SP126-B-S.....	159
	P8SAGMCHX.....	165	PS 32/44.....	48	PWSB1227.....	197, 199	SP126-V-L.....	159
	P8SAGMFAX.....	165	PS 40/44.....	48	PWSB1337.....	197, 199	SP126-V-S.....	159
	P8SAGMFDX.....	165	PS 40/60.....	48	PWSB1557.....	197, 199	SP128-B-L.....	159
	P8SAGNCHX.....	165	PS 50/60.....	48	PWSB1887.....	197, 199	SP128-B-S.....	159
	P8SAGNFAX.....	165	PS 50/76.....	48	PWSB1997.....	197, 199	SP128-V-L.....	159
OSP-P Series	P8SAGNFDX.....	165	PSBJ708-2G.....	216	PWSM1012.....	197, 199	SP128-V-S.....	159
	P8SAGPCHX.....	165	PSBJ708-4G.....	216	PWSP111.....	197, 199	STL16.....	57
	P8SAGPFAX.....	165	PSBJ731-0.....	216	SKED3000N115.....	184	STL25.....	57
	P8SAGPFAXS.....	165	PSBJ731-2.....	216	SL16.....	43	STL32.....	57
P1X Series	P8SAGPFDX.....	165	PSBJ731-2G.....	216	SL25.....	43	STL40.....	57
	P8SAGPFLX.....	165	PSBJ731-4.....	216	SL32.....	43	STL50.....	57
	P8SAGPFTX.....	165	PSBJ731-4G.....	216	SL40.....	43	W68PLCK-4-2.....	213
	P8SAGQCHX.....	165	PSBJ731-6.....	216	SL50.....	43	W68PLCK-4-4.....	213
GDL Series	P8SAGQFAX.....	165	PSBJ731-6G.....	216	SL63.....	43	W68PLCK-5/32-2.....	213
	P8SAGQFDX.....	165	PSBJ731-8.....	216	SL80.....	43	W68PLCK-6-4.....	213
	P8SAGQFLX.....	165	PSBJ731-8G.....	216	SP16-B-1.....	159	W68PLCK-6-6.....	213
	P8SAGRCHX.....	165	PSBJ731-M5.....	216	SP16-B-2.....	159	W68PLCKI-4-2.....	213
2002/P120 Series	P8SAGRFX.....	165	PSPE701-2G.....	216	SP16-V-1.....	159	W68PLCKI-4-4.....	213
	P8SAGRFDX2.....	165	PSPE701-4G.....	216	SP16-V-2.....	159	W68PLCKI-5/32-2.....	213
	P8SAGRFLX1.....	165	PSPE701-6G.....	216	SP25R-B-1.....	159	W68PLCKI-6-4.....	213
	P8SAGRFLX2.....	165	PSPE701-8G.....	216	SP25R-B-2.....	159	W68PLCKI-6-6.....	213
P55 Electronic & Reed Sensors	P8SAGRFTX1.....	165	PSPE701-M5.....	216	SP25R-V-1.....	159	WDV3-G12BL.....	183
	P8SAGSCHX.....	165	PSPJ731-2.....	216	SP25R-V-2.....	159	WDV3-G13BL.....	183
	P8SAGSFAX.....	165	PSPJ731-4.....	216	SP32R-B-1.....	159	WDV3-G14BL.....	183
	P8SAGSFDX.....	165	PSPJ731-6.....	216	SP32R-B-2.....	159	WDV3-G22BL.....	183
Accessories	P8SAGSFLX.....	165	PUR IP67.....	165	SP32R-V-1.....	159	WDV3-G23BL.....	183
	P8SAGSFTX.....	165	PVC IP67.....	165	SP32R-V-2.....	159	WDV3-G24BL.....	183
	P8S-TMA0Y.....	169	PWBA1412/3412.....	199	SP40R-B-1.....	159	WDV3-G34BL.....	183
	P8S-TMA09.....	169	PWBA1468/3468.....	199	SP40R-B-2.....	159	ZSM25HD.....	76
Part Number Index	PL16.....	52	PWBA1469/3469.....	199	SP40R-V-1.....	159		
	PL25.....	52	PWBA1483.....	199	SP40R-V-2.....	159		
	PL32.....	52	PWBA1489.....	199	SP50R-B-1.....	159		
	PL40.....	52	PWBA1493/3493.....	199	SP50R-B-2.....	159		
Safety Guide, Offer of Sale	PL50.....	52	PWBA1822/3822.....	199	SP50R-V-1.....	159		
	PPS1-2C3-RHM.....	189	PWBA1833/3833.....	199	SP50R-V-2.....	159		
	PPS1-2C3-RWL.....	189	PWBA1898/3888.....	199	SP124-B-L.....	159		



For inventory, lead times, and kit lookup, visit www.pdnplu.com

Safety Guide For Selecting And Using Pneumatic Division Products And Related Accessories



WARNING:

FAILURE OR IMPROPER SELECTION OR IMPROPER USE OF PNEUMATIC DIVISION PRODUCTS, ASSEMBLIES OR RELATED ITEMS (“PRODUCTS”) CAN CAUSE DEATH, PERSONAL INJURY, AND PROPERTY DAMAGE. POSSIBLE CONSEQUENCES OF FAILURE OR IMPROPER SELECTION OR IMPROPER USE OF THESE PRODUCTS INCLUDE BUT ARE NOT LIMITED TO:

- Unintended or mistimed cycling or motion of machine members or failure to cycle
- Work pieces or component parts being thrown off at high speeds.
- Failure of a device to function properly for example, failure to clamp or unclamp an associated item or device.
- Explosion
- Suddenly moving or falling objects.
- Release of toxic or otherwise injurious liquids or gasses.

Before selecting or using any of these Products, it is important that you read and follow the instructions below.

1. GENERAL INSTRUCTIONS

- 1.1. Scope:** This safety guide is designed to cover general guidelines on the installation, use, and maintenance of Pneumatic Division Valves, FRLs (Filters, Pressure Regulators, and Lubricators), Vacuum products and related accessory components.
- 1.2. Fail-Safe:** Valves, FRLs, Vacuum products and their related components can and do fail without warning for many reasons. Design all systems and equipment in a fail-safe mode, so that failure of associated valves, FRLs or Vacuum products will not endanger persons or property.
- 1.3. Relevant International Standards:** For a good guide to the application of a broad spectrum of pneumatic fluid power devices see: ISO 4414:1998, Pneumatic Fluid Power – General Rules Relating to Systems. See www.iso.org for ordering information.
- 1.4. Distribution:** Provide a copy of this safety guide to each person that is responsible for selection, installation, or use of Valves, FRLs or Vacuum products. Do not select, or use Parker valves, FRLs or vacuum products without thoroughly reading and understanding this safety guide as well as the specific Parker publications for the products considered or selected.
- 1.5. User Responsibility:** Due to the wide variety of operating conditions and applications for valves, FRLs, and vacuum products Parker and its distributors do not represent or warrant that any particular valve, FRL or vacuum product is suitable for any specific end use system. This safety guide does not analyze all technical parameters that must be considered in selecting a product. The user, through its own analysis and testing, is solely responsible for:
 - Making the final selection of the appropriate valve, FRL, Vacuum component, or accessory.
 - Assuring that all user’s performance, endurance, maintenance, safety, and warning requirements are met and that the application presents no health or safety hazards.
 - Complying with all existing warning labels and / or providing all appropriate health and safety warnings on the equipment on which the valves, FRLs or Vacuum products are used; and,
 - Assuring compliance with all applicable government and industry standards.
- 1.6. Safety Devices:** Safety devices should not be removed, or defeated.
- 1.7. Warning Labels:** Warning labels should not be removed, painted over or otherwise obscured.
- 1.8. Additional Questions:** Call the appropriate Parker technical service department if you have any questions or require any additional information. See the Parker publication for the product being considered or used, or call 1-800-CPARKER, or go to www.parker.com, for telephone numbers of the appropriate technical service department.

2. PRODUCT SELECTION INSTRUCTIONS

- 2.1. Flow Rate:** The flow rate requirements of a system are frequently the primary consideration when designing any pneumatic system. System components need to be able to provide adequate flow and pressure for the desired application.
- 2.2. Pressure Rating:** Never exceed the rated pressure of a product. Consult product labeling, Pneumatic Division catalogs or the instruction sheets supplied for maximum pressure ratings.
- 2.3. Temperature Rating:** Never exceed the temperature rating of a product. Excessive heat can shorten the life expectancy of a product and result in complete product failure.
- 2.4. Environment:** Many environmental conditions can affect the integrity and suitability of a product for a given application. Pneumatic Division products are designed for use in general purpose industrial applications. If these products are to be used in unusual circumstances such as direct sunlight and/or corrosive or caustic environments, such use can shorten the useful life and lead to premature failure of a product.
- 2.5. Lubrication and Compressor Carryover:** Some modern synthetic oils can and will attack nitrile seals. If there is any possibility of synthetic oils or greases migrating into the pneumatic components check for compatibility with the seal materials used. Consult the factory or product literature for materials of construction.
- 2.6. Polycarbonate Bowls and Sight Glasses:** To avoid potential polycarbonate bowl failures:
 - Do not locate polycarbonate bowls or sight glasses in areas where they could be subject to direct sunlight, impact blow, or temperatures outside of the rated range.
 - Do not expose or clean polycarbonate bowls with detergents, chlorinated hydro-carbons, keytones, esters or certain alcohols.
 - Do not use polycarbonate bowls or sight glasses in air systems where compressors are lubricated with fire resistant fluids such as phosphate ester and di-ester lubricants.

Rodless Pneumatic Cylinders
OSP-P Series
P1X Series
GDL Series
2002/P120 Series
P55 Electronic & Reed Sensors
Accessories
Part Number Index
Safety Guide, Offer of Sale



For inventory, lead times, and kit lookup, visit www.pdnplu.com

Safety Guide

Rodless Pneumatic Cylinders	<p>2.7. Chemical Compatibility: For more information on plastic component chemical compatibility see Pneumatic Division technical bulletins Tec-3, Tec-4, and Tec-5</p> <p>2.8. Product Rupture: Product rupture can cause death, serious personal injury, and property damage.</p> <ul style="list-style-type: none"> • Do not connect pressure regulators or other Pneumatic Division products to bottled gas cylinders. • Do not exceed the maximum primary pressure rating of any pressure regulator or any system component. • Consult product labeling or product literature for pressure rating limitations. <p>3. PRODUCT ASSEMBLY AND INSTALLATION INSTRUCTIONS</p> <p>3.1. Component Inspection: Prior to assembly or installation a careful examination of the valves, FRLs or vacuum products must be performed. All components must be checked for correct style, size, and catalog number. DO NOT use any component that displays any signs of nonconformance.</p> <p>3.2. Installation Instructions: Parker published Installation Instructions must be followed for installation of Parker valves, FRLs and vacuum components. These instructions are provided with every Parker valve or FRL sold, or by calling 1-800-CPARKER, or at www.parker.com.</p> <p>3.3. Air Supply: The air supply or control medium supplied to Valves, FRLs and Vacuum components must be moisture-free if ambient temperature can drop below freezing</p>
OSP-P Series	<p>4. VALVE AND FRL MAINTENANCE AND REPLACEMENT INSTRUCTIONS</p> <p>4.1. Maintenance: Even with proper selection and installation, valve, FRL and vacuum products service life may be significantly reduced without a continuing maintenance program. The severity of the application, risk potential from a component failure, and experience with any known failures in the application or in similar applications should determine the frequency of inspections and the servicing or replacement of Pneumatic Division products so that products are replaced before any failure occurs. A maintenance program must be established and followed by the user and, at minimum, must include instructions 4.2 through 4.10.</p> <p>4.2. Installation and Service Instructions: Before attempting to service or replace any worn or damaged parts consult the appropriate Service Bulletin for the valve or FRL in question for the appropriate practices to service the unit in question. These Service and Installation Instructions are provided with every Parker valve and FRL sold, or are available by calling 1-800-CPARKER, or by accessing the Parker web site at www.parker.com.</p>
P1X Series	<p>4.3. Lockout / Tagout Procedures: Be sure to follow all required lockout and tagout procedures when servicing equipment. For more information see: OSHA Standard – 29 CFR, Part 1910.147, Appendix A, The Control of Hazardous Energy – (Lockout / Tagout)</p> <p>4.4. Visual Inspection: Any of the following conditions requires immediate system shut down and replacement of worn or damaged components:</p> <ul style="list-style-type: none"> • Air leakage: Look and listen to see if there are any signs of visual damage to any of the components in the system. Leakage is an indication of worn or damaged components. • Damaged or degraded components: Look to see if there are any visible signs of wear or component degradation. • Kinked, crushed, or damaged hoses. Kinked hoses can result in restricted air flow and lead to unpredictable system behavior. • Any observed improper system or component function: Immediately shut down the system and correct malfunction. • Excessive dirt build-up: Dirt and clutter can mask potentially hazardous situations. <p>Caution: Leak detection solutions should be rinsed off after use.</p>
GDL Series	<p>4.5. Routine Maintenance Issues:</p> <ul style="list-style-type: none"> • Remove excessive dirt, grime and clutter from work areas. • Make sure all required guards and shields are in place. <p>4.6. Functional Test: Before initiating automatic operation, operate the system manually to make sure all required functions operate properly and safely.</p> <p>4.7. Service or Replacement Intervals: It is the user's responsibility to establish appropriate service intervals. Valves, FRLs and vacuum products contain components that age, harden, wear, and otherwise deteriorate over time. Environmental conditions can significantly accelerate this process. Valves, FRLs and vacuum components need to be serviced or replaced on routine intervals. Service intervals need to be established based on:</p> <ul style="list-style-type: none"> • Previous performance experiences. • Government and / or industrial standards. • When failures could result in unacceptable down time, equipment damage or personal injury risk. <p>4.8. Servicing or Replacing of any Worn or Damaged Parts: To avoid unpredictable system behavior that can cause death, personal injury and property damage:</p> <ul style="list-style-type: none"> • Follow all government, state and local safety and servicing practices prior to service including but not limited to all OSHA Lockout Tagout procedures (OSHA Standard – 29 CFR, Part 1910.147, Appendix A, The Control of Hazardous Energy – Lockout / Tagout). • Disconnect electrical supply (when necessary) before installation, servicing, or conversion. • Disconnect air supply and depressurize all air lines connected to system and Pneumatic Division products before installation, service, or conversion. • Installation, servicing, and / or conversion of these products must be performed by knowledgeable personnel who understand how pneumatic products are to be applied. • After installation, servicing, or conversions air and electrical supplies (when necessary) should be connected and the product tested for proper function and leakage. If audible leakage is present, or if the product does not operate properly, do not put product or system into use. • Warnings and specifications on the product should not be covered or painted over. If masking is not possible, contact your local representative for replacement labels.
2002/P120 Series	<p>4.9. Putting Serviced System Back into Operation: Follow the guidelines above and all relevant Installation and Maintenance Instructions supplied with the valve FRL or vacuum component to insure proper function of the system.</p>
P55 Electronic & Reed Sensors	
Accessories	
Part Number Index	
Safety Guide, Offer of Sale	



For inventory, lead times, and kit lookup, visit www.pdnplu.com

224

Parker Hannifin Corporation
 Pneumatic Division
 Wadsworth, OH
www.parkeroriga.com

**PARKER-HANNIFIN CORPORATION
OFFER OF SALE**

1. Definitions. As used herein, the following terms have the meanings indicated.

- Buyer:** means any customer receiving a Quote for Products.
- Goods:** means any tangible part, system or component to be supplied by Seller.
- Products:** means the Goods, Services and/or Software as described in a Quote.
- Quote:** means the offer or proposal made by Seller to Buyer for the supply of Products.
- Seller:** means Parker-Hannifin Corporation, including all divisions and businesses thereof.
- Services:** means any services to be provided by Seller.
- Software:** means any software related to the Goods, whether embedded or separately downloaded.
- Terms:** means the terms and conditions of this Offer of Sale.

2. Terms. All sales of Products by Seller are expressly conditioned upon, and will be governed by the acceptance of, these Terms. These Terms are incorporated into any Quote provided by Seller to Buyer. Buyer's order for any Products whether communicated to Seller verbally, in writing, by electronic data interface or other electronic commerce, shall constitute acceptance of these Terms. Seller objects to any contrary or additional terms or conditions of Buyer. Reference in Seller's order acknowledgement to Buyer's purchase order or purchase order number shall in no way constitute an acceptance of any of Buyer's terms or conditions of purchase. No modification to these Terms will be binding on Seller unless agreed to in writing and signed by an authorized representative of Seller.

3. Price; Payment. The Products set forth in the Quote are offered for sale at the prices indicated in the Quote. Unless otherwise specifically stated in the Quote, prices are valid for thirty (30) days and do not include any sales, use, or other taxes or duties. Seller reserves the right to modify prices at any time to adjust for any raw material price fluctuations. Unless otherwise specified by Seller, all prices are F.C.A. Seller's facility (INCOTERMS 2020). All sales are contingent upon credit approval and full payment for all purchases is due thirty (30) days from the date of invoice (or such date as may be specified in the Quote). Unpaid invoices beyond the specified payment date incur interest at the rate of 1.5% per month or the maximum allowable rate under applicable law.

4. Shipment; Delivery; Title and Risk of Loss. All delivery dates are approximate, and Seller is not responsible for damages resulting from any delay. Regardless of the manner of shipment, delivery occurs and title and risk of loss or damage pass to Buyer, upon placement of the Products with the carrier at Seller's facility. Unless otherwise agreed prior to shipment and for domestic delivery locations only, Seller will select and arrange, at Buyer's sole expense, the carrier and means of delivery. When Seller selects and

arranges the carrier and means of delivery, freight and insurance costs for shipment to the designated delivery location will be prepaid by Seller and added as a separate line item to the invoice. Buyer shall be responsible for any additional shipping charges incurred by Seller due to Buyer's acts or omissions. Buyer shall not return or repackage any Products without the prior written authorization from Seller, and any return shall be at the sole cost and expense of Buyer.

5. Warranty. The warranty for the Products is as follows: (i) Goods are warranted against defects in material or workmanship for a period of twelve (12) months from the date of delivery or 2,000 hours of use, whichever occurs first; (ii) Services shall be performed in accordance with generally accepted practices and using the degree of care and skill that is ordinarily exercised and customary in the field to which the Services pertain and are warranted for a period of six (6) months from the date of completion of the Services; and (iii) Software is only warranted to perform in accordance with applicable specifications provided by Seller to Buyer for ninety (90) days from the date of delivery or, when downloaded by a Buyer or end-user, from the date of the initial download. All prices are based upon the exclusive limited warranty stated above, and upon the following disclaimer: **EXEMPTION CLAUSE: DISCLAIMER OF WARRANTY, CONDITIONS, REPRESENTATIONS: THIS WARRANTY IS THE SOLE AND ENTIRE WARRANTY, CONDITION, AND REPRESENTATION, PERTAINING TO PRODUCTS. SELLER DISCLAIMS ALL OTHER WARRANTIES, CONDITIONS, AND REPRESENTATIONS, WHETHER STATUTORY, EXPRESS OR IMPLIED, INCLUDING BUT NOT LIMITED TO THOSE RELATING TO DESIGN, NONINFRINGEMENT, MERCHANTABILITY, AND FITNESS FOR A PARTICULAR PURPOSE. SELLER DOES NOT WARRANT THAT THE SOFTWARE IS ERROR-FREE OR FAULT-TOLERANT, OR THAT BUYER'S USE THEREOF WILL BE SECURE OR UNINTERRUPTED. UNLESS OTHERWISE AUTHORIZED IN WRITING BY SELLER, THE SOFTWARE SHALL NOT BE USED IN CONNECTION WITH HAZARDOUS OR HIGH RISK ACTIVITIES OR ENVIRONMENTS. EXCEPT AS EXPRESSLY STATED HEREIN, ALL PRODUCTS ARE PROVIDED "AS IS".**

6. Claims; Commencement of Actions. Buyer shall promptly inspect all Products upon receipt. No claims for shortages will be allowed unless reported to Seller within ten (10) days of delivery. Buyer shall notify Seller of any alleged breach of warranty within thirty (30) days after the date the non-conformance is or should have been discovered by Buyer. Any claim or action against Seller based upon breach of contract or any other theory, including tort, negligence, or otherwise must be commenced within twelve (12) months from the date of the alleged breach or other alleged event, without regard to the date of discovery.

7. LIMITATION OF LIABILITY. IN THE EVENT OF A BREACH OF WARRANTY, SELLER WILL, AT ITS OPTION, REPAIR OR REPLACE THE NON-CONFORMING PRODUCT, RE-PERFORM THE SERVICES, OR REFUND THE PURCHASE PRICE PAID WITHIN A REASONABLE PERIOD OF TIME. **IN NO EVENT IS SELLER LIABLE FOR**

08/20

Rodless Pneumatic Cylinders
OSP-P Series
P1X Series
GDL Series
2002/P120 Series
P55 Electronic & Reed Sensors
Accessories
Part Number Index
Safety Guide, Offer of Sale



For inventory, lead times, and kit lookup, visit www.pdnplu.com

Rodless Pneumatic Cylinders
OSP-P Series
P1X Series
GDL Series
2002/P120 Series
P55 Electronic & Reed Sensors
Accessories
Part Number Index
Safety Guide, Offer of Sale

ANY SPECIAL, INDIRECT, INCIDENTAL OR CONSEQUENTIAL DAMAGES INCLUDING ANY LOSS OF REVENUE OR PROFITS, WHETHER BASED IN CONTRACT, TORT OR OTHER LEGAL THEORY. IN NO EVENT SHALL SELLER'S LIABILITY UNDER ANY CLAIM MADE BY BUYER EXCEED THE PURCHASE PRICE PAID FOR THE PRODUCTS.

8. Confidential Information. Buyer acknowledges and agrees that any technical, commercial, or other confidential information of Seller, including, without limitation, pricing, technical drawings or prints and/or part lists, which has been or will be disclosed, delivered or made available, whether directly or indirectly, to Buyer ("Confidential Information"), has been and will be received in confidence and will remain the property of Seller. Buyer further agrees that it will not use Seller's Confidential Information for any purpose other than for the benefit of Seller.

9. Loss to Buyer's Property. Any tools, patterns, materials, equipment or information furnished by Buyer or which are or become Buyer's property ("Buyer's Property"), will be considered obsolete and may be destroyed by Seller after two (2) consecutive years have elapsed without Buyer ordering the Products manufactured using Buyer's Property. Furthermore, Seller shall not be responsible for any loss or damage to Buyer's Property while it is in Seller's possession or control.

10. Special Tooling. "Special Tooling" includes but is not limited to tools, jigs, fixtures and associated manufacturing equipment acquired or necessary to manufacture Goods. Seller may impose a tooling charge for any Special Tooling. Such Special Tooling shall be and remain Seller's property notwithstanding payment of any charges by Buyer. In no event will Buyer acquire any interest in the Special Tooling, even if such Special Tooling has been specially converted or adapted for manufacture of Goods for Buyer and notwithstanding any charges paid by Buyer. Unless otherwise agreed, Seller has the right to alter, discard or otherwise dispose of any Special Tooling or other property owned by Seller in its sole discretion at any time.

11. Security Interest. To secure payment of all sums due from Buyer, Seller retains a security interest in all Products delivered to Buyer and, Buyer's acceptance of these Terms is deemed to be a Security Agreement under the Uniform Commercial Code. Buyer authorizes Seller as its attorney to execute and file on Buyer's behalf all documents Seller deems necessary to perfect Seller's security interest.

12. User Responsibility. Buyer, through its own analysis and testing, is solely responsible for making the final selection of the Products and assuring that all performance, endurance, maintenance, safety and warning requirements of the application of the Products are met. Buyer must analyze all aspects of the application and follow applicable industry standards, specifications, and any technical information provided with the Quote or the Products, such as Seller's instructions, guides and specifications. If Seller provides options of or for Products based upon data or specifications provided by Buyer, Buyer is responsible for determining that such data and specifications are suitable and sufficient for all applications and reasonably foreseeable uses of the Products. In the event Buyer is not the end-user

of the Products, Buyer will ensure such end-user complies with this paragraph.

13. Use of Products, Indemnity by Buyer. Buyer shall comply with all instructions, guides and specifications provided by Seller with the Quote or the Products. **Unauthorized Uses.** If Buyer uses or resells the Products in any way prohibited by Seller's instructions, guides or specifications, or Buyer otherwise fails to comply with Seller's instructions, guides and specifications, Buyer acknowledges that any such use, resale, or non-compliance is at Buyer's sole risk. Further, Buyer shall indemnify, defend, and hold Seller harmless from any losses, claims, liabilities, damages, lawsuits, judgments and costs (including attorney fees and defense costs), whether for personal injury, property damage, intellectual property infringement or any other claim, arising out of or in connection with: (a) improper selection, design, specification, application, or any misuse of Products; (b) any act or omission, negligent or otherwise, of Buyer; (c) Seller's use of patterns, tools, equipment, plans, drawings, designs, specifications or other information or things furnished by Buyer; (d) damage to the Products from an external cause, repair or attempted repair by anyone other than Seller, failure to follow instructions, guides and specifications provided by Seller, use with goods not provided by Seller, or opening, modifying, deconstructing, tampering with or repackaging the Products; or (e) Buyer's failure to comply with these Terms. Seller shall not indemnify Buyer under any circumstance except as otherwise provided in these Terms.

14. Cancellations and Changes. Buyer may not cancel or modify, including but not limited to movement of delivery dates for the Products, any order for any reason except with Seller's written consent and upon terms that will indemnify, defend and hold Seller harmless against all direct, incidental and consequential loss or damage and any additional expense. Seller, at any time, may change features, specifications, designs and availability of Products.

15. Limitation on Assignment. Buyer may not assign its rights or obligations without the prior written consent of Seller.

16. Force Majeure. Seller is not liable for delay or failure to perform any of its obligations by reason of events or circumstances beyond its reasonable control. Such circumstances include without limitation: accidents, labor disputes or stoppages, government acts or orders, acts of nature, pandemics, epidemics, other widespread illness, or public health emergency, delays or failures in delivery from carriers or suppliers, shortages of materials, war (whether declared or not) or the serious threat of same, riots, rebellions, acts of terrorism, fire or any reason whether similar to the foregoing or otherwise. Seller will resume performance as soon as practicable after the event of force majeure has been removed. All delivery dates affected by force majeure shall be tolled for the duration of such force majeure and rescheduled for mutually agreed dates as soon as practicable after the force majeure condition ceases to exist. Force majeure shall not include financial distress, insolvency, bankruptcy, or other similar conditions affecting one of the parties, affiliates and/or subcontractors.

08/20



For inventory, lead times, and kit lookup, visit www.pdnplu.com

17. Waiver and Severability. Failure to enforce any provision of these Terms will not invalidate that provision; nor will any such failure prejudice either party's right to enforce that provision in the future. Invalidation of any provision of these Terms shall not invalidate any other provision herein and, the remaining provisions will remain in full force and effect.

18. Termination. Seller may terminate any agreement governed by or arising from these Terms for any reason and at any time by giving Buyer thirty (30) days prior written notice. Seller may immediately terminate, in writing, if Buyer: (a) breaches any provision of these Terms, (b) becomes or is deemed insolvent, (c) appoints or has appointed a trustee, receiver or custodian for all or any part of Buyer's property, (d) files a petition for relief in bankruptcy on its own behalf, or one is filed against Buyer by a third party, (e) makes an assignment for the benefit of creditors; or (f) dissolves its business or liquidates all or a majority of its assets.

19. Ownership of Software. Seller retains ownership of all Software supplied to Buyer hereunder. In no event shall Buyer obtain any greater right in and to the Software than a right in the nature of a license limited to the use thereof and subject to compliance with any other terms provided with the Software.

20. Indemnity for Infringement of Intellectual Property Rights. Seller is not liable for infringement of any patents, trademarks, copyrights, trade dress, trade secrets or similar rights ("Intellectual Property Rights") except as provided in this Section. Seller will defend at its expense and will pay the cost of any settlement or damages awarded in an action brought against Buyer based on a third party claim that one or more of the Products sold hereunder infringes the Intellectual Property Rights of a third party in the country of delivery of the Products by Seller to Buyer. Seller's obligation to defend and indemnify Buyer is contingent on Buyer notifying Seller within ten (10) days after Buyer becomes aware of any such claim, and Seller having sole control over the defense of the claim including all negotiations for settlement or compromise. If one or more Products sold hereunder is subject to such a claim, Seller may, at its sole expense and option, procure for Buyer the right to continue using the Products, replace or modify the Products so as to render them non-infringing, or offer to accept return of the Products and refund the purchase price less a reasonable allowance for depreciation. Seller has no obligation or liability for any claim of infringement: (i) arising from information provided by Buyer; or (ii) directed to any Products provided hereunder for which the designs are specified in whole or part by Buyer; or (iii) resulting from the modification, combination or use in a system of any Products provided hereunder. The foregoing provisions of this Section constitute Seller's sole and exclusive liability and Buyer's sole and exclusive remedy for claims of infringement of Intellectual Property Rights.

21. Governing Law. These Terms and the sale and delivery of all Products are deemed to have taken place in, and shall be governed and construed in accordance with, the laws of the State of Ohio, as applicable to contracts executed and wholly performed therein and without regard to conflicts of laws principles. Buyer irrevocably agrees and consents to the exclusive jurisdiction and venue of the courts of

Cuyahoga County, Ohio with respect to any dispute, controversy or claim arising out of or relating to the sale and delivery of the Products.

22. Entire Agreement. These Terms, along with the terms set forth in the main body of any Quote, forms the entire agreement between the Buyer and Seller and constitutes the final, complete and exclusive expression of the terms of sale and purchase. In the event of a conflict between any term set forth in the main body of a Quote and these Terms, the terms set forth in the main body of the Quote shall prevail. All prior or contemporaneous written or oral agreements or negotiations with respect to the subject matter shall have no effect. These Terms may not be modified unless in writing and signed by an authorized representative of Seller.

23. Compliance with Laws. Buyer agrees to comply with all applicable laws, regulations, and industry and professional standards, including those of the United States of America, and the country or countries in which Buyer may operate, including without limitation the U.S. Foreign Corrupt Practices Act ("FCPA"), the U.S. Anti-Kickback Act ("Anti-Kickback Act"), U.S. and E.U. export control and sanctions laws ("Export Laws"), the U.S. Food Drug and Cosmetic Act ("FDCA"), and the rules and regulations promulgated by the U.S. Food and Drug Administration ("FDA"), each as currently amended. Buyer agrees to indemnify, defend, and hold harmless Seller from the consequences of any violation of such laws, regulations and standards by Buyer, its employees or agents. Buyer acknowledges that it is familiar with all applicable provisions of the FCPA, the Anti-Kickback Act, Export Laws, the FDCA and the FDA and certifies that Buyer will adhere to the requirements thereof and not take any action that would make Seller violate such requirements. Buyer represents and agrees that Buyer will not make any payment or give anything of value, directly or indirectly, to any governmental official, foreign political party or official thereof, candidate for foreign political office, or commercial entity or person, for any improper purpose, including the purpose of influencing such person to purchase Products or otherwise benefit the business of Seller. Buyer further represents and agrees that it will not receive, use, service, transfer or ship any Products from Seller in a manner or for a purpose that violates Export Laws or would cause Seller to be in violation of Export Laws. Buyer agrees to promptly and reliably provide Seller all requested information or documents, including end-user statements and other written assurances, concerning Buyer's ongoing compliance with Export Laws.

Rodless Pneumatic Cylinders
OSP-P Series
P1X Series
GDL Series
2002/P120 Series
P55 Electronic & Reed Sensors
Accessories
Part Number Index
Safety Guide, Offer of Sale

08/20



For inventory, lead times, and kit lookup, visit www.pdnplu.com

Catalog 0961-1 11/2020

Parker Hannifin Corporation
Pneumatic Division
135 Quadral Drive
Wadsworth, OH 44281 USA

Tel: 330 336 3511
Fax: 330 334 3335
website www.parkeroriga.com
E-mail: pdncustsvc@parker.com

