



Guardian[®]

Portable Filtration System



ENGINEERING YOUR SUCCESS.

Guardian[®]

Portable Filtration System



The Guardian portable filtration system is a unique pump/motor/filter combination designed for conditioning and transferring petroleum-based and water emulsion fluids. It protects your system from contamination added with new fluid because new fluid is not necessarily clean fluid. Most new fluids right out of the drum are unfit for use due to high initial concentrations of contaminants. Contamination may be added to a new fluid during processing, mixing, handling, and storage.

The Guardian also circulates and “polishes” fluid in your existing systems to reduce the contamination to an acceptable level. There are hundreds of applications that the Guardian is suited for, with more being discovered each day. If your system is sensitive to the harmful effects of contamination, then the Guardian may be ideal for you.

Features	Advantages	Benefits
Lightweight, hand held, compact design	Easy to carry and fits easily on top of 55 gallon drums.	One person operation, capable of getting to hard to reach areas.
Flow rate to 4 gpm (18 lpm).	Filters and transfers simultaneously.	One step operation.
Pump/motor combination with Carboxylated Nitrile seals standard.	Handles fluids up to 16,000 SUS viscosity (11,000 SUS -24 VDC).	Reliable performance in a wide variety of operating conditions.
Built-in relief valve with no downstream fluid bypass.	Only filtered fluid reaches downstream components.	100% filtration ensured, even when unattended.
Wide variety of filter elements available.	High capacity 2 micron absolute disposable microglass to 74 micron cleanable wire and water removal.	Maximizes element life between changes.
Clear, wire-reinforced 5' hose assemblies with wand attachments.	No additional hardware required.	Ready to use and easy to maneuver.
Optional quick disconnect hose connections.	Fast, easy setup and tear-down.	Eliminates messy drips.
Heavy-duty ¼ HP, 115 VAC (230 VAC, 24 VDC- optional) motor with thermal overload protection.	UL recognized and CSA listed, with replaceable brushes.	Safe, reliable performance; field serviceable.
Gerotor pump with visible serviceable inlet strainer.	Dirt tolerant design with added protection.	Pump reliability in highly contaminated fluids.
Quiet operation.	Less than 70dB noise level @ 3 feet.	Can be used most anywhere with minimal disturbance.
Convenient inlet-to-outlet hose connection.	Contains fluids when transporting.	Clean and safe operation.
Low center of gravity.	Guardian stability.	Unattended reliability.
Dual motor seals.	Added motor protection.	Longer motor life.
Auxiliary inlet/outlet ports.	Used in place of, or in addition to, standard ports. The outlet can also be used as a sampling port.	Flexibility.

Guardian[®]

Specifications and Installation

Maximum Allowable Operating Pressure (MAOP)
50 psi (3.4 bar)
Flow Capacity
Up to 4 gpm (15 lpm)
Maximum Recommended Fluid Viscosity
(.85 specific gravity) 110-120 VAC and 220-240 VAC - 16,000 SUS 24 VDC - 11,000 SUS
Warning
Explosion hazard. Do not pump flammable liquids such as gasoline, alcohol, solvents, etc.
Ambient Operating Temperature
-15°F to 104°F (-26°C to 40°C)
Fluid Operating Temperature
-15°F to 120°F (-26°C to 49°C)
Visual Indicator
Differential pressure type, set at 25 psid (1.7 bar)
Recommended Fluids
Petroleum based oils, water emulsions, and diesel fuels
Integral Relief Valve
Set at 50 psi (3.4 bar) for motor protection.
Noise Level
<70db at 3 ft.
Electrical Motor
¼ hp@2500 rpm. 24 VDC; 10A max. 110-120 VAC; 50/60 Hz; 3A max. 220-240 VAC; 50/60 Hz; 1.5A max. Thermal overload protected. Replaceable brushes (500 hours).
Weight
Approximately 24 lbs (10.8 kg)
Materials
Housing - cast aluminum Cover - die cast aluminum Handle and Indicator - nylon Wands and Hose - PVC Fittings - brass Seals - fluorocarbon/carboxylated nitrile

Dimensions

mm
in

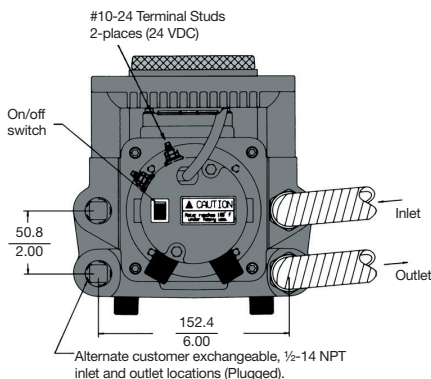
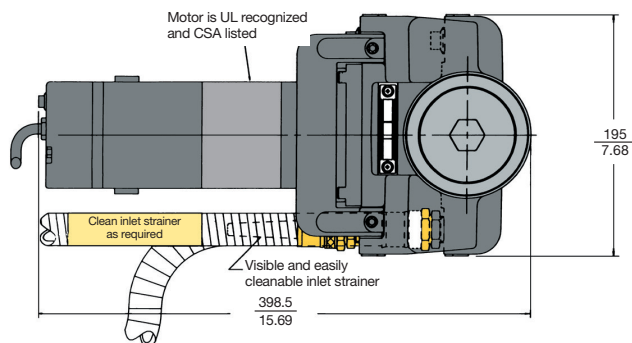
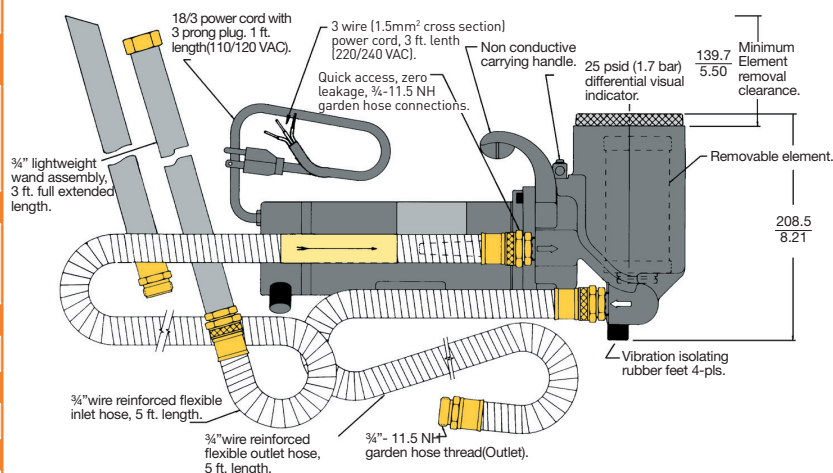

Guardian Schematic

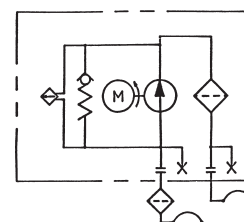

Guardian®

Element Performance

Media Code	Filter Media	Time Averaged Beta x/y/z =2/20/75 Where x/y/z is:	Dirt Capacity (Grams)
74W	Woven Wire	74 micron ¹	*
40W	Woven Wire	40 micron ¹	*
25W	Woven Wire	25 micron ¹	*
20C	Cellulose	20 micron ¹	*
10C	Cellulose	5/8/16	4
20Q	Microglass	7.1/13.7/17.3	16.2
10Q	Microglass	2.7/7.3/10.3	14.4
05Q	Microglass	<2/2.1/4.0	14.9
02Q	Microglass	<2/<2/<2	14.3

Beta Rating	Efficiency at x Particle Size
B _x = 2	50.0%
B _x = 20	95.0%
B _x = 75	98.7%
B _x = 200	99.5%
B _x = 1000	99.9%

Multipass test run at 4 gpm (15 lpm) to 35 psid (2.4 bar)
¹Reference ratings only. Not multipass tested due to coarseness.
 * Not applicable

Estimated Guardian Element Life and Cleanliness Levels

The following chart shows typical element life (in gallons of oil passed) and cleanliness levels achieved by standard Parker elements available with the Guardian. Some assumptions have been made.*

Media Code	New Oil ISO	ISO Achieved	Element Life	Elements Used per 250 gallons
10C	22/20/16	21/19/15	120 gallons	2.08
20Q	22/20/16	21/19/15	486 gallons	.51
10Q	22/20/16	19/16/14	407 gallons	.61
05Q	22/20/16	17/15/12	330 gallons	.75
02Q	22/20/16	15/13/10	316 gallons	.79

* 1. New oil is at ISO 22/20/16.
 2. No environment or work ingress.
 3. Single pass oil transfer.

NOTE: Data for fluid transfer only. For continuous fluid polishing, lower ISO cleanliness levels will be achieved.

Guardian Flow vs. Viscosity Performance

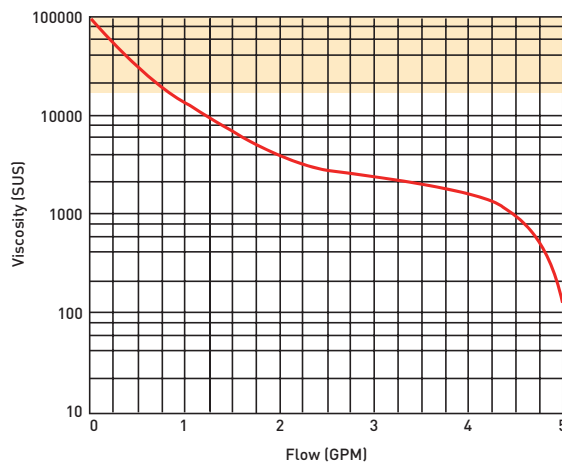

Note 1: Guardian not recommended for fluid viscosities greater than 16,000 SUS (11,000 SUS;24VDC)

Note 2: Flows based on Guardian with no element installed

Guardian®

Replacement Parts

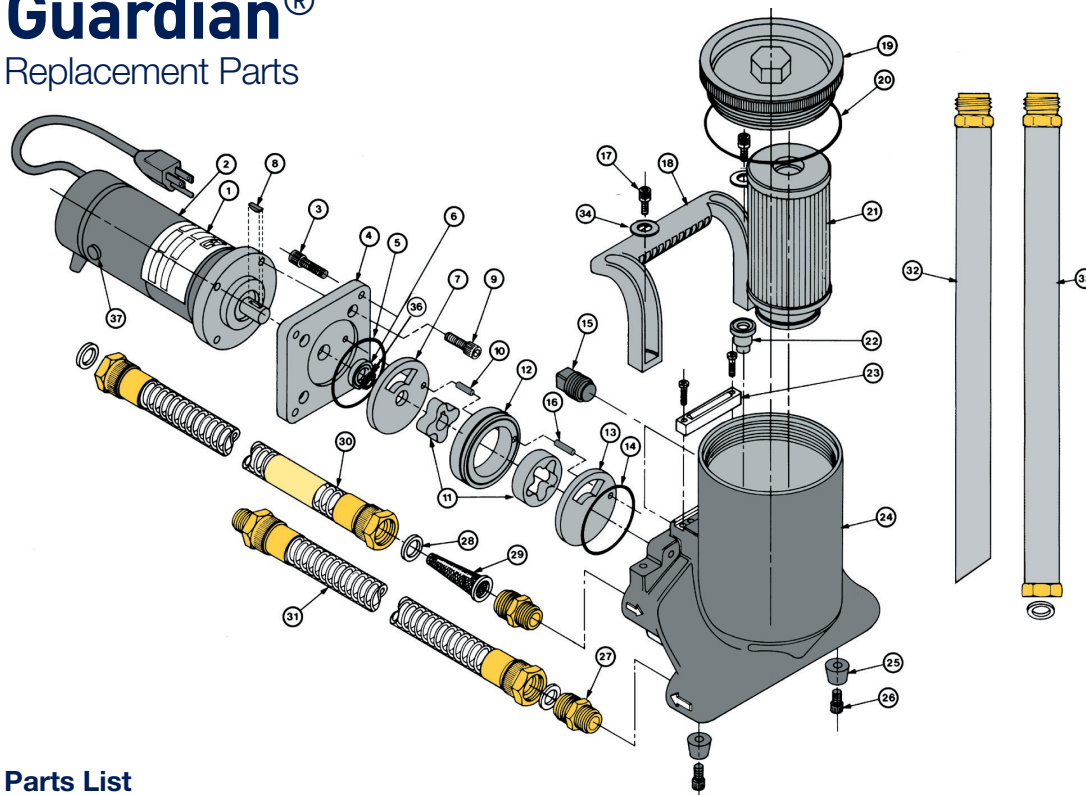

Parts List

#	Part Number	Description
1	CF	LABEL
2	931913	MOTOR (110-120 VAC)
	932381	MOTOR (220-440 VAC)
	932759	MOTOR (24 VDC)
3	902734	SOCKET HEAD CAP SCREW (4), ¼-20X1
4	931890	ADAPTER PLATE
5	V72041	HOUSING O-RING
6	931921	POLYPAK SEAL
7	931899	SHADOW PLATE
8	931877	WOODRUFF KEY 1/8 X 3/8
9	902679	SOCKET HEAD CAP SCREW (4), ¼-20 X ¾
10	903630	ROLL PIN 1/8 X ¾
11	931873	GEROTER SET
12	931903	GEROTER RING
13	931900	OUTLET PLATE
14	V72135	GEROTER O-RING
15	931920	BRASS PIPE PLUG (2) ½-14
16	903426	Roll Pin 1/8 x 5/8
17	931889	SOCKET HEAD CAP SCREW (2), ¼-20 x 5/8
18	931897	HANDLE
19	931892	COVER
20	V72237	COVER O-RING

#	Part Number	Description
21	SEE 44	ELEMENT
22	928981	RELIEF VALVE
23	927422	INDICATOR KIT
24	931838	HOUSING
25	931888	RUBBER BUMPERS (2)
26	902907	SOCKET HEAD CAP SCREW (2), ¼-20 x ½
27	931928	BRASS FITTING (2)
28	931956	GASKET (4)
29	931927	INLET SCREEN
30	931936	INLET HOSE ASSEMBLY
31	931937	OUTLET HOSE ASSEMBLY
32	931965	WAND CREVICE ASSEMBLY
33	931966	WAND ADAPTER ASSEMBLY
34	926106	WASHER (2)
35	932097	QUICK DISCONNECT KIT (NOT SHOWN)
36	932085	WASHER
	934329	BRUSH KIT (110/120 VAC)
	934327	BRUSH KIT (220/240 VAC)
	932761	BRUSH KIT (24 VDC)
	932263	SEAL KIT
	932081	BOWL EXTENSION KIT

CF - Consult Factory

Guardian Operation

- A. Remove all shipping plugs from the hoses and fittings.
- B. Connect the inlet and outlet hose assemblies to the unit.
- C. Connect the wand assemblies, if required.
- D. Place the inlet hose wand assembly into the fluid to be filtered and/or transferred.
- E. Place the outlet hose/wand assembly into the container where the fluid discharge is desired.
- F. Plug in the unit.
- G. Flip the switch on the end of the unit to the “on” position.

NOTE: For no-mess transportation, the inlet and outlet hose assemblies can be screwed together by removing the wand assembly.

Guardian Element Servicing

- A. Flip the switch on the end of the unit to the “off” position and disconnect the electrical plug.
- B. Rotate the cover counter-clockwise and remove.
- C. Remove the element from the housing. Discard all disposable elements. These elements are not cleanable.
- D. Place the new element in the housing, fitting the o-ring neck into the large hole at the bottom.
- E. Inspect the cover o-ring and replace if necessary.
- F. Replace the cover and hand-tighten.

NOTE 1: It is recommended that the Guardian be cleaned and flushed between uses with dissimilar fluids to prevent fluid mixing.

NOTE 2: Motor brushes may require changeout every 500 service hours

Troubleshooting Guide

Problem	Cause	Solution
Does not start.	ON/OFF switch. No electrical power. Rectifier. Motor overheats (160°F). Defective motor.	Turn switch on, replace switch if defective. Plug in Guardian, check for tripped circuit breakers, check for blown fuses. Replace if defective. Allow motor to cool, thermal overload will automatically reset. Replace motor.
Does not start or erratic motor noise.	Worn motor brushes.	Replace motor brushes.
Intermittent start/stop operation.	High viscosity fluids. Worn motor brushes. Defective motor.	High viscosity fluids can cause the motor to overheat and cycle intermittently. Replace motor brushes. Replace motor.
Hot motor.	Pumping under heavy load. Defective motor.	It is normal, under a heavy pumping load for the motor to reach 160°F. Replace motor if shell temperature reaches greater than 170°F.
No flow or erratic pump noise.	Filter housing not filled with oil. Suction leak. Obstructed outlet. Element dirty. Sheared pump key. Defective Guardian.	Allow Guardian to run a few seconds. Check tightness of inlet fittings and hoses. Check gaskets are in place and are not damaged. Kink or restriction in the inlet hose. Clear outlet. Replace or clean element. Replace woodruff key. Replace unit.
No flow, erratic pump noise, motor overheats.	Gears binding.	Disassemble Guardian and thoroughly clean the gear set. Always use the inlet strainer provided to protect the unit. Replace defective gears.
No suction.	Plugged strainer.	Clean or replace the inlet strainer as required. Clean relief valve. Check for damaged internal o-rings.
Reduced oil flow.	High viscosity fluids. Element dirty. Relief valve sticks or is lodged open. Partially obstructed inlet or outlet hose. Suction leak. Worn gears.	High viscosity fluids can cause reduced flow, which is normal. Replace or clean element. Clean relief valve or replace if defective. Clear the hose obstruction. Check tightness of inlet fittings and hose. Replace gear set.
Indicator moves to RED Area.	Element dirty. Oil extremely cold or viscous. Obstructed outlet. Defective indicator.	Replace or clean element. Change element to coarser micron rating. Clear outlet obstruction. Replace indicator.
Indicator does not seem to move.	No element. Defective indicator.	Install element. Replace indicator.
Hoses discolor or are hard.	Fluid compatibility.	Certain fluids, over time, will cause the hoses to discolor. This does not impair their performance. But, some fluids will cause the hoses to become brittle, requiring replacement.
Oil formation under unit.	Defective shaft seal.	Replace the motor shaft seal.

Guardian Replacement Parts

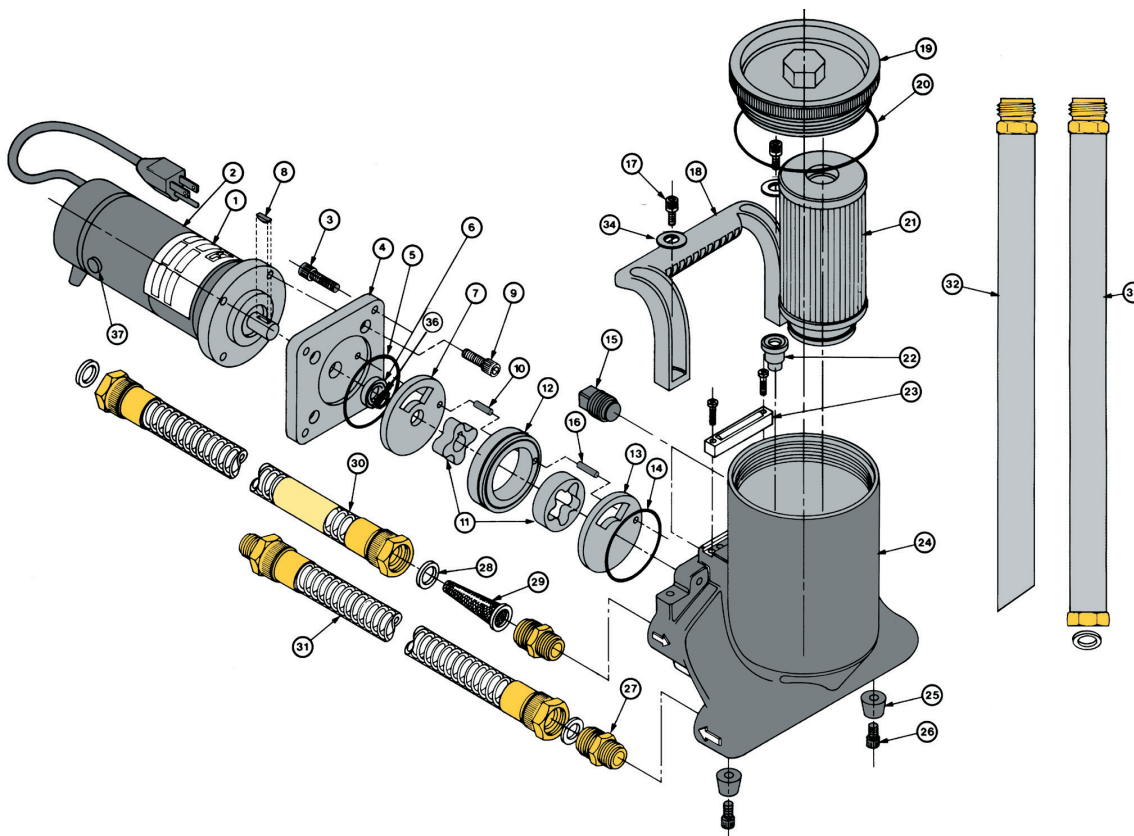

Item No.	Description	PN
1	Label	Consult Factory
2	Motor, 110-120 VAC	931913
	220-440 VAC	932381
	24 VDC	932759
3	SHCS(4), 1/4-20x1	902734
4	Adapter Plate	931890
5	Housing O-Ring	V72041
6	Polypak Seal	931921
7	Shadow Plate	931899
8	Woodruff Key 1/8 x 3/8	931877
9	SHCS(4), 1/4-20 x 3/4	902679
10	Roll Pin 1/8 x 3/4	903630
11	Geroter Set	931873
12	Geroter Ring	931903
13	Outlet Plate	931900
14	Geroter O-ring	V72135
15	Brass Pipe Plug (2) 1/2-14	931920
16	Roll Pin 1/8 x 5/8	903426
17	SHCS (2), 1/4-20 x 5/8	931889
18	Handle	931897
19	Cover	931892
20	Cover O-Ring	V72237

Item No.	Description	PN
21	Element (see next page)	
22	Relief Valve	928981
23	Indicator Kit	927422
24	Housing	931838
25	Rubber Bumpers (2)	931888
26	SHCS(2), 1/4-20 x 1/2	902907
27	Brass Fitting (2)	931928
28	Gasket (4)	931956
29	Inlet Screen	931927
30	Inlet Hose Assembly	931936
31	Outlet Hose Assembly	931937
32	Wand Crevice Assembly	931965
33	Wand Adapter Assembly	931966
34	Washer (2)	926106
35	Quick Disconnect Kit (Not Shown)	932097
36	Washer	932085
37	Brush Kit (110/120)	934329
	(220/240 VAC)	934327
	(24 VDC)	932761
	Seal Kit	932263
	Bowl Extension Kit	932081

NOTE: SHCS denotes "socket head cap screw"

Guardian Series

Portable Filtration System

How To Order

Select the desired symbol (in the correct position) to construct a model code.

Example:

BOX 1	BOX 2	BOX 3	BOX 4
	GT4	10C	1

BOX 1: Seals	
Symbol	Description
None	Carboxylated Nitrile

BOX 2: Model	
Symbol	Description
GT4	Guardian® 110/120 VAC
GT4D	24 VDC
GT4E	220/240 VAC

BOX 3: Media	
Symbol	Description
25W	Wire Mesh
40W	Wire Mesh
74W	Wire Mesh
10C	Cellulose
02Q	Microglass, 2 micron
05Q	Microglass, 5 micron
10Q	Microglass, 10 micron
20Q	Microglass, 20 micron
WR	Water Removal

BOX 4: Options	
Symbol	Description
1	None
6	Quick disconnect hose connections

Please note the bolded options reflect standard options with a reduced lead time.

Replacement Elements

Media	Part No.	Box Qty.
02Q	933467Q	2
05Q	932018Q	2
10Q	932017Q	2
20Q	933468Q	2
10C	932016	2

Media	Part No.	Box Qty.
20C	932020	2
25W	922627	1
40W	922628	1
74W	922626	1
WR	932019	2

Global products as identified are offered worldwide through all Parker locations and utilize a common ordering code.

