

L90LS

Mobile Directional Control Valve

Proportional, Load Sensing, Pre-compensated



ENGINEERING YOUR SUCCESS.

Catalogue layout

In addition to general information and basic technical data, this catalogue contains descriptions of the many optional functions you can configure for the L90LS, so that we may customize it to control your machine optimally. Apart from general information and technical data, the catalogue also contains descriptions of the optional functions available within the various functional domains of the valve.

Each function area of the valve is given as a subheading, followed by a brief description. When different options are available for a function area, the subheading has an item number in square brackets, e.g. [P16] Pressure relief valve. This is followed by a series of coded options, e.g. PA1, PS, Y, together with a brief description of what each code represents.

Alternatively, one or more pressure, flow or voltage options are given.

On page 8 is a general hydraulic schematic, which shows the basic function areas of the L90LS valve, as well as the item numbers that represent them.

Early consultation with Parker saves time and money

Our experienced engineers have in-depth knowledge of different types of hydraulic system and the ways in which they work. They are at your disposal to offer expert advice on the best system for the desired combination of machine functions, control characteristics and economic criteria. By consulting Parker early in the project planning stage, you are assured of a comprehensive hydraulic system that gives your machine the best possible operating and control characteristics.

This is how you order your valve

We have developed a computer program to configure the L90LS on the basis of the criteria for each individual machine function. The program facilitates optimal configuration of the valve for maximum performance in different applications. It also generates documentation in the form of a detailed specification, 3D and 2D drawing, spare part list and hydraulic schematic for your valve. This software also creates a unique ID number that is printed into the valve name plate. Your valve configurations are then stored on our database to facilitate rapid identification in the event of service enquiries or re-ordering.

Parker reserves the right to modify products without prior notice. Typical curves and diagrams are used in this catalogue. Even though the catalogue is revised and updated continuously, there is always the possibility of errors. For more detailed information about the products, please contact Parker Hannifin.



WARNING – USER RESPONSIBILITY

FAILURE OR IMPROPER SELECTION OR IMPROPER USE OF THE PRODUCTS DESCRIBED HEREIN OR RELATED ITEMS CAN CAUSE DEATH, PERSONAL INJURY AND PROPERTY DAMAGE.

This document and other information provided by Parker-Hannifin Corporation, its affiliates and authorized distributors, provides product or system options for further investigation of users with technical expertise.

The user, through its own analysis and testing, is solely responsible for making the final selection of the system and components and assuring that all performance, endurance, maintenance, safety and warning requirements of the application are met. The user must analyze all aspects of the application, follow applicable industry standards, and follow the information concerning the product in the current product catalog and in any other materials provided from Parker or its subsidiaries or authorized distributors.

To the extent that Parker or its subsidiaries or authorized distributors provide component or system options based upon data or specifications provided by the user, the user is responsible for determining that such data and specifications are suitable and sufficient for all applications and reasonably foreseeable uses of the components or systems.

Offer of Sale

Please contact your Parker representation for a detailed "Offer of Sale".



Contents	Page
General Information.....	4
Technical Data.....	5-7
Hydraulic schematics.....	8-9
Inlet sections.....	10
[P15-P29] Inlet section.....	10
[P15] Inlet sections.....	10
[P16] Pressure relief valve / [P17] Pressure relief valve.....	12
[P16] Pressure relief valve / [P17] Pressure setting.....	12
[P16] Pressure relief valve / [P17] Pressure setting.....	13
[P20] Load signal system.....	14
[P22] Pump-unloading function.....	15
P22V variant pump unloading function.....	15
[P25] Tank connection T1.....	15
[P26] Pump connection P1.....	15
End section.....	16
[P30] End section.....	16
[P31] LS connection.....	17
[P32] Pump connection P2.....	17
[P33] Counter pressure valve / tank connection T2.....	17
[P34] Tank connection T3.....	17
[P37] Internal-pilot pressure supply.....	17
[P39] Pilot filter.....	17
[P40] Tank connection for pilot circuit.....	17
[P31] LS connection.....	18
[P32] Pump connection P2.....	18
[P33] Counter pressure valve / tank connection T2.....	18
[P37] Internal-pilot pressure supply.....	18
[P39] Pilot filter.....	18
[P40] Tank connection for pilot circuit.....	18
Work section.....	19
[P45-P89] Work section.....	19
[P47] Basic variants of work section.....	19
[P50] Spool actuators.....	20
[P51] Lever brackets.....	23
[P55 A, B] Pilot restrictor.....	24
[P56] Connector types.....	24
[P51] Lever bracket.....	25
[P60] Spool function.....	26
[P64A, B] Force feedback.....	27
[P66] Pressure compensator / load-hold check valve.....	28
[P69] Spool designation.....	29
[P71A, B] Nominal flow to workport.....	29
[P72] Flow settings.....	29
[P72A] Desired setting flow.....	29
[P72B] Desired setting flow.....	29
[P75] Feed-reducing valve.....	29
[P75A] Setting of feed reduction in the A-port.....	29
[P75B] Setting of feed reduction in the B-port.....	29
[P76A, B] Port relief and/or anti-cavitation valves.....	30
System functions.....	31
[P80] System signal lines.....	31
[P81] Individual LS connections.....	31
[P85] Internal connection of workport.....	32
[P89A, B] Variant workport.....	32
Function manifolds.....	33
[P90-99] Function manifolds.....	33
Accessories.....	33
Information.....	34
Dimensional drawings.....	35
Spare parts.....	36

[00] refers to item number in customer specification

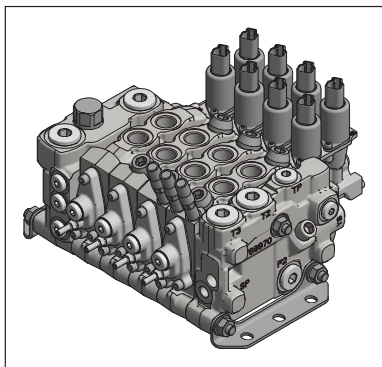

L90LS with work sections.

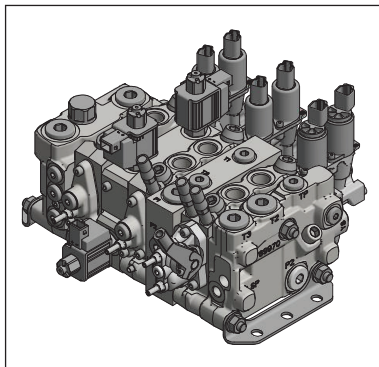

L90LS with work sections and function manifolds.

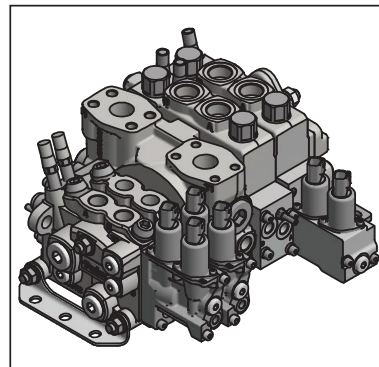

L90LS in combination with K220LS.

The L90LS is a sectionally-built, load sensing, directional control valve for mobile machinery. The valve is characterised by industry-leading properties regarding robustness, control precision and energy efficiency.

It has a wide range of selectable functions, offering great flexibility in terms of system structure in simple as well as advanced hydraulic system solutions. The L90LS can be equipped with manually operated, hydraulic or electrohydraulic spool actuators in any combination. Each valve section can be optimised for its particular function in the machinery, with a large range of spools, pressure relief valves, pressure compensators, signal pressure limiters and other performance-enhancing functions.

The L90LS can be constructed in many different designs, with different inlet sections, work sections and end sections. The L90LS can also be combined with the bigger K220LS directional valve in order to further optimise functional performance in machinery with large variations in flow requirement.

For complete customer-specific functional adaptation and to accommodate every conceivable need in terms of auxiliary function control, the L90LS can be combined with tailor-made function manifolds consisting of components from Parker.

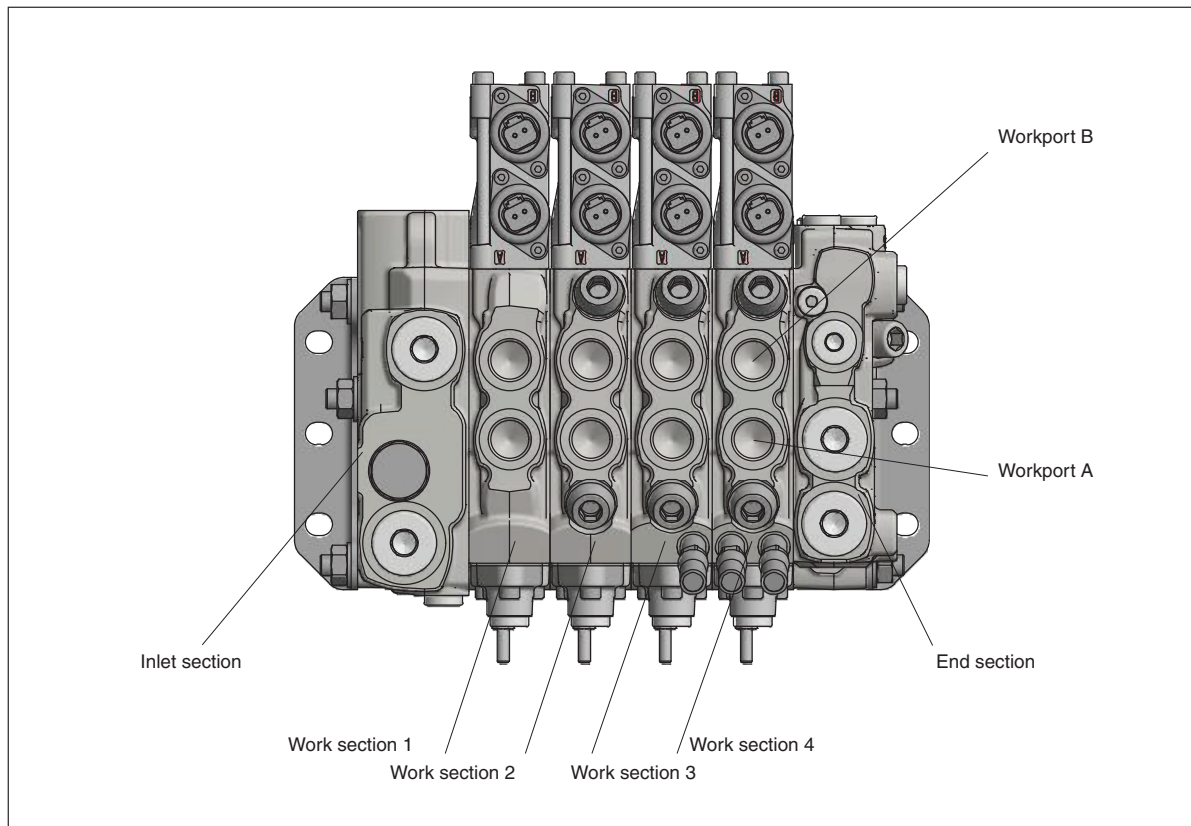

Pressures

Pump inlet	330 bar
Workports	350 bar
Tank, static	max. 20 bar

Internal pilot pressure

Fixed setting	22, 28, 35 or 43 bar
---------------	----------------------

Flow capacity

Pump connection	max. 230 l/min
Workport, with pressure compensator LS*	130 l/min
Workport, with pressure compensator AS*	130 l/min
Workport, without pressure compensator*	160 l/min

* = Indicated at ΔP 20 bar above valve pressure

Weight

[P15] Inlet section LS1, LS2, AS, AS2, CFC	5.5 kg
[P15] Inlet section LS2C, ASC	11.5 kg
[P30] End section US	4.2 kg

Combined work- and end section, MU compared with work sections below add 1.2 kg

Work section with spool actuator type:	
C, B3	4.1 kg
CH2, PC	4.5 kg
PCH2	4.7 kg
EC2	5.2 kg
ECH3	5.4 kg

Filtration

Filtration must be arranged so that Target Contamination Class 20/18/14 according to ISO 4406 is not exceeded. For the pilot circuit, Target Contamination Class 18/16/13 according to ISO 4406 must not be exceeded.

Hydraulic fluids

Best performance is obtained using mineral-base oil of high quality and cleanness in the hydraulic system. Hydraulic fluids of type HLP (DIN 51524), oil for automatic gearboxes Type A and engine oil type API CD can be used.

Viscosity, working range	15-380 mm ² /s**
--------------------------	-----------------------------

Technical information in this catalogue is applicable at an oil viscosity of 30 mm²/s and temperature of 50 °C using nitrile rubber HNBR or NBR.

** Product operating limits are broadly within the above range, but satisfactory operation within the specification may not be accomplished. Leakage and response time will be affected when used at temperature extremes and it is up to the user to determine acceptability at these levels. Performance efficiency will be reduced if the product is used outside the ideal values. These extreme conditions must be evaluated by the user to establish suitability of the product.

Temperature

Oil temperature, working range	+20 to 90 °C**
Oil temperature start-up, functional range	-30°C to 100°C**



Technical data

[P03] Pump regulator setting

The pressure difference in bar at the valve between pump and load signal (PX-PL) is indicated here. The stated value applies when max. flow is taken off from the valve. The stated value applies when the pump is not overdemand.

Connections

Unless stated otherwise, all standard connections are available in two versions: G-version (BSP pipe thread) for flat seal as per ISO 228/1 and UNF-version for O-ring seal as per ISO 11926-1. Depending on the configuration, some connections shown in pictures may be missing.

[P04] Connection thread

G G-version (BSP pipe thread) for flat seal as per ISO 228/1

U UNF-version for O-ring seal as per ISO 11926-1.

Inlet sections

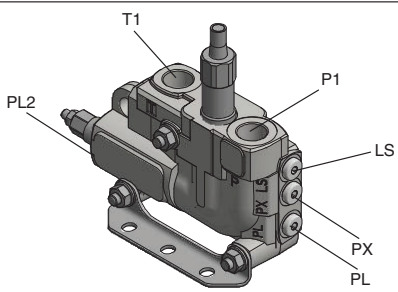

Inlet [P15] AS		
Connection	[P04] G	[P04] U
P1	G 3/4	1 1/16-12 UN-2B
T1	G 3/4	1 1/16-12 UN-2B
LS, PX, PL, PL2	G 1/4	9/16-18 UNF-2B

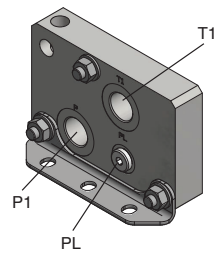

Inlet [P15] IP		
Connection	[P04] G	[P04] U
P1	G 3/4	1 1/16-12 UN-2B
T1	G 3/4	1 1/16-12 UN-2B
PL	G 1/4	9/16-18 UNF-2B

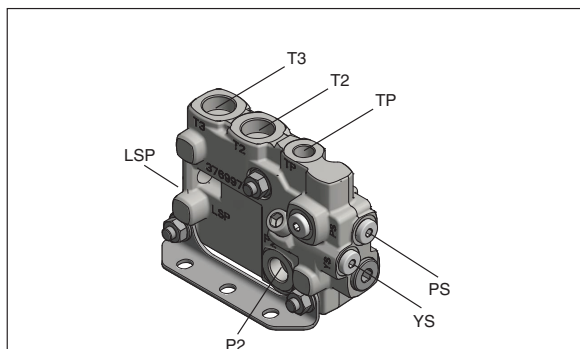
End section

End section [P30] US

Connection	[P04] G	[P04] U
T2, T3	G 3/4	1 1/16-12 UN-2B
P2	G 1/2	7/8-14 UNF-2B
TP	G 3/8	3/4 -16 UNF-2B
PS	G 1/4	9/16-18 UNF-2B
LSP	G 1/4	9/16-18 UNF-2B
YS	G 1/4	9/16-18 JIC (37°) (male)

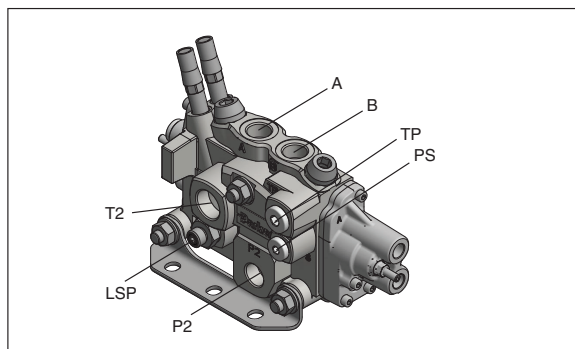
Spool/end section

End section [P30] MU

Connection	[P04] G	[P04] U
T2	G 3/4	1 1/16-12 UN-2B
P2	G 1/2	7/8-14 UNF-2B
TP	G 3/8	3/4-16-UNF-2B
PS	G 1/4	9/16-18 UNF-2B
LSP	9/16-18 UNF-2A (ORFS male adapter)	
A, B	G 1/2	7/8-14 UNF-2B

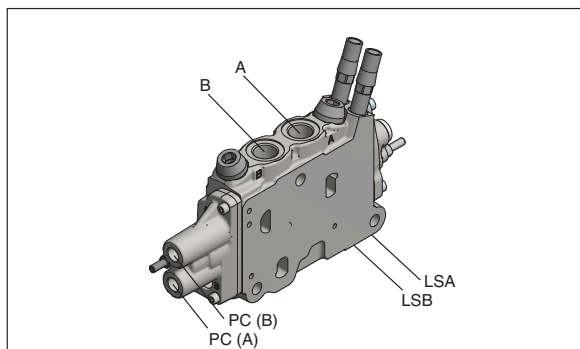
Work section

Work section [P30]

Connection	[P04] G	[P04] U
A, B	G 1/2	7/8-14 UNF-2B
PC	G 1/4	9/16-18 UNF-2B
LSA/LSB	G 1/8	7/16-20 UNF-2B

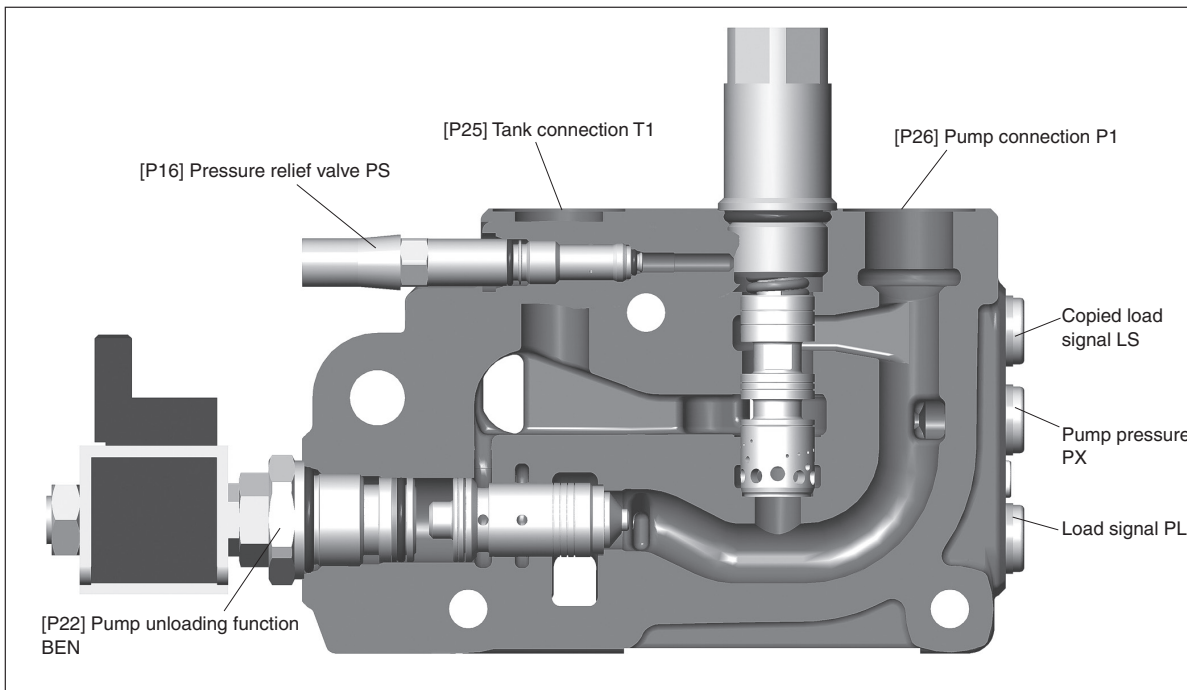

Inlet section CFC alt. LS1 with pump unloading function.

[P15-P29] Inlet section

There are two types of inlet, depending on the choice of compensator [P66] in the work sections. If work sections only have LS compensators, a [P15] LS1, LS2, IP or LS2C inlet is used with a variable pump, or CFC with a fixed pump.

If any work section has an [P66] AS compensator, use a [P15] AS, AS2 or ASC inlet.

[P15] Inlet section

CFC Inlet section used when all work sections have a [P66] LS compensator. For fixed-pump systems, the inlet has a built-in bypass function which regulates excess oil straight to the tank. Can only be used in the first valve in a system. (Can be converted to an LS1 inlet). Recommended pump flow max. 175 l/min.

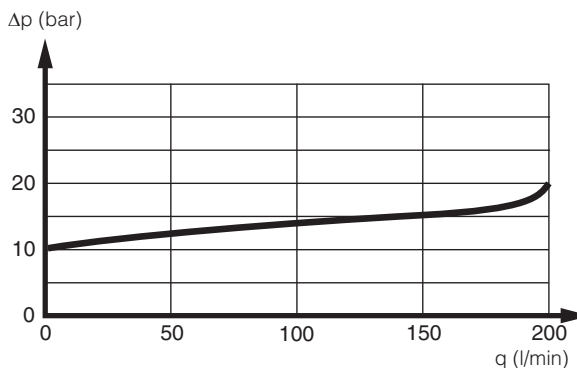

CFC –Idling pressure drop over bypass. P1 –T1.

LS1 Inlet section used when all work sections have a [P66] LS compensator. Inlet section for systems with variable pump. Can be used both in the first and in subsequent valves in a system. (Convertible to a CFC inlet.)

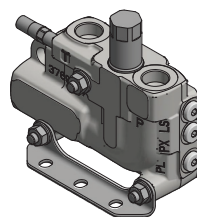

CFC, LS1

Inlet section
Mobile Directional Control Valve
L90LS

- LS2** Inlet section used when all work sections have a [P66] LS compensator. For systems with a variable pump. Can be used both in the first and in subsequent valves in a system.
- LS2C** Inlet section, which combines directional control valve L90LS with directional control valve K220LS. Used, when all work sections have a [P66] LS compensator. For systems with a variable pump. Can be used both in the first and in subsequent valves in a system.
LS2C can contain an internal pilot pressure supply and counterpressure function, so in many cases the end section [P30] MU can be used in L90LS.
The choice of options for LS2C are made in K220LS.
- AS** Inlet section used if any of the work sections have a [P66] AS compensator. For systems with a variable pump. Can only be used in the first valve in a system.
- AS2** Inlet section used if any of the work sections have a [P66] AS compensator. For systems with variable pump. Can only be used in the subsequent valves in a system.
- ASC** Inlet section, which combines directional control valve L90LS with directional control valve K220LS. Used if any of the work sections have a [P66] AS compensator. For systems with a variable pump. Can only be used in the first valve in a system.
ASC can contain an internal pilot pressure supply and counterpressure function, so in many cases end section, [P30] MU, can be used in L90LS. The choice of options for ASC are made in K220LS.
- IP** Inlet plate without functions. Contains only connections for pump, tank and load signal. Inlet section used when all work sections have a [P66] LS compensator. For systems with variable pump. Can be used both in the first and in subsequent valves in a system.

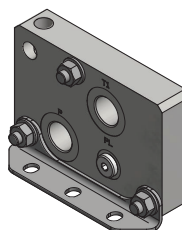
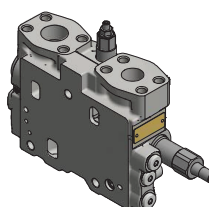
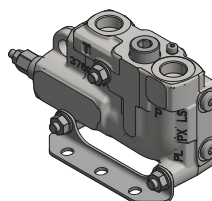
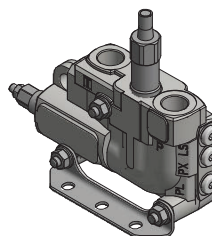
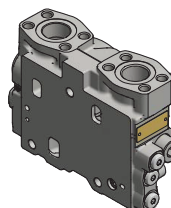
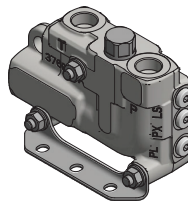

Inlet section

**Mobile Directional Control Valve
L90LS**

**For inlet [P15] CFC, LS1
[P16] Pressure relief valve
[P17] Pressure setting**

PS [P16] Pilot-operated pressure relief valve with fast opening sequence and very flat characteristics, which effectively prevents overloading of the hydraulic pump, opening a connection between pump and tank. The setting value for PS is selectable between 50 and 350 bar in [P17].

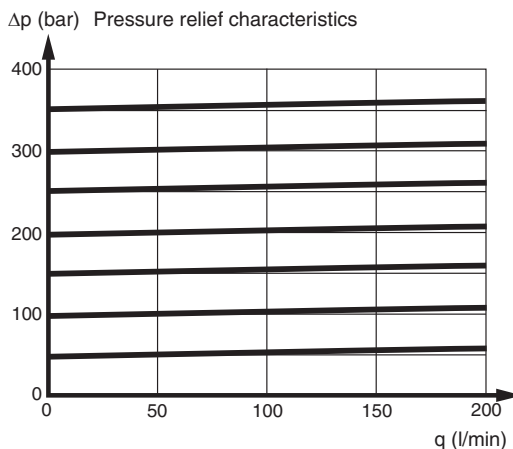
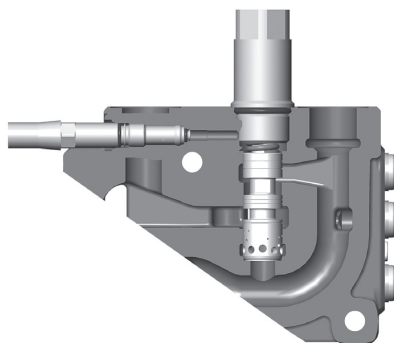

PS - Pilot-operated pressure relief valve

PS – Pilot-operated pressure relief valve for inlet section CFC and LS1.

**For inlet [P15] LS2
[P16] Pressure relief valve
[P17] Pressure setting**

Y [P16] Blocks the connection between the pump and tank.

PA1 [P16] Direct acting pressure relief valve with fixed setting, with rapid opening sequence and good pressure characteristics. Acts as a shock valve in the pump channel. When the pressure relief valve opens, it creates a connection from pump to tank. The following settings are available:
Pressure setting in bar: [P17]: 32, 50, 63, 80, 100, 125, 140, 160, 175, 190, 210, 230, 240, 250, 260, 270, 280, 300, 320, 350, 380, 400, 420.

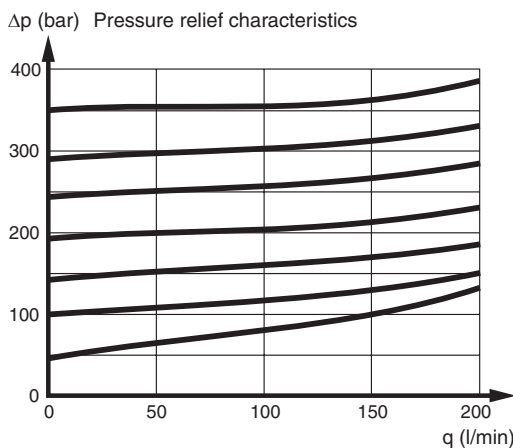
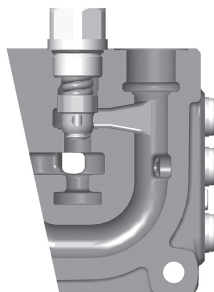

PA1 - Direct acting pressure relief valve.

PA1 – Direct acting pressure relief valve.

Inlet section

For inlet [P15] AS, AS2

[P16] Pressure relief valve

[P17] Pressure setting

[P18] PLS

PLM [P16] Together with inlet section [P15] AS, AS2:
Adjustable signal pressure limitation valve, which limits the load signal pressure to the pump.

The pump's regulator setting, which is given in [P03], is added to the load signal, thus producing the max. pressure in the pump channel. Setting value for PLM, max. pump pressure, is selectable between 175 and 350 bar in [P17]. In order for [P66] AS compensators to work correctly, the main pressure level must always be limited using the PLM function.

/ Cavity not machined for pressure limitation valve.

PLS [P18] Combined with PLM, it becomes a pilot-controlled adjustable pressure limitation valve. Acts as a pressure relief valve in the pump channel, which limits the pressure difference between pump pressure and load signal pressure in order to prevent disruptions in functions with [P66] AS compensators.

When PLS opens, a connection is established between the pump and the tank. Pilot control for PLS is taken from the load signal.

PLS setting is selectable between 20 and 38 bar.

[P15] AS2 does not have [P18] PLS function. (AS2 has a cavity plug in the PLS cavity, so it can be converted to PLS function.)

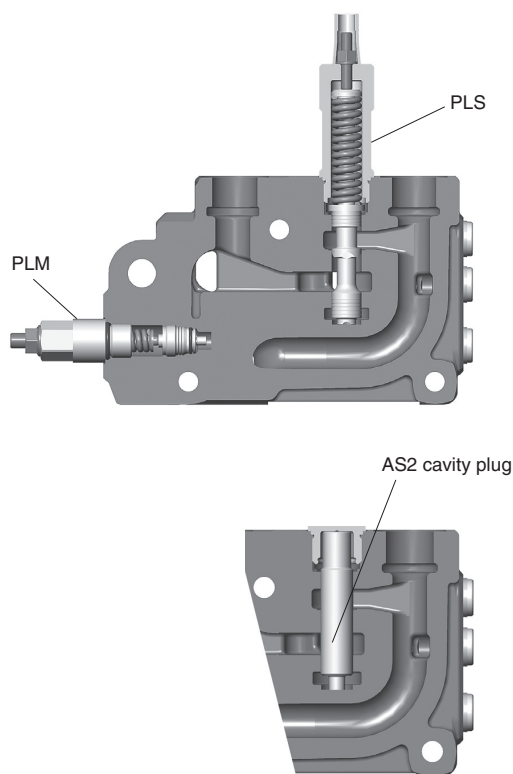

Inlet section

[P20] Load signal system

The load-signal system consists of a number of shuttle valves which compare the load signals from the work sections and any incoming signal from a subsequent valve connected to the LSP port [P31].

The highest load pressure is sent to the pump via connection PL in the inlet section or to a copy spool if the inlet section has one. The copied load signal can then be tapped from the LS port.

KB Inlet section machined for copy spool but blocked. (Can be rebuilt to KS).

The load signal goes directly to the bypass in inlet section CFC, for other inlet sections the load signal goes to PL and LS connection.

KS Inlet section with copy spool.

The load signal acts on a copy spool, which sends a copied load signal to the LS connection.

The system permits a certain consumption in the load signal line to the pump regulator, without the load signal being influenced, since the copied load signal in LS is supplied with oil from the pump channel instead of taking oil from a workport.

In addition, the system prevents disruptive micro-dipping of the load during the initial stage of the lifting phase.

The copied load signal goes to the shunt for inlet section CFC; for other inlet sections, the load signal goes straight to connection LS.

/ The inlet section is not machined for copy spool.

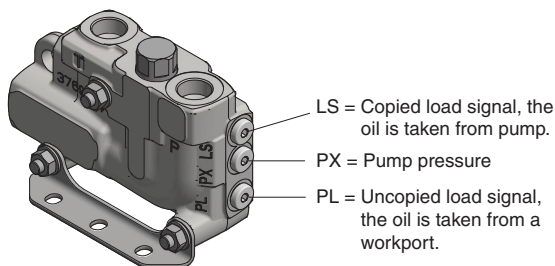

Inlet section

[P22] Pump-unloading function

Inlet section CFC, LS1, LS2 can be equipped with a pump-unloading function in the inlet section. This enables machine manufacturers to equip their machines with an emergency-stop function to comply with the EC Machinery Directive. The function can be controlled either electrically or hydraulically.

BEN Electrically controlled pump-unloading function with manual emergency operation.
When there is no current to the electromagnet, the pump connection from the inlet section to the work sections is blocked and the load signal drained to the tank.

Connector AMP Junior-Timer type C.

BX Hydraulically controlled pump-unloading function. When an external hydraulic signal with the same or higher pressure than the pump is connected to the BX port, the pump connection from the inlet section to the work sections is blocked and the load signal drained to the tank.
Connection: G1/4 or 9/16-18 UNF-2B.

BB Inlet section machined for pump unloading function, but delivered with a cavity plug.

/ Not machined for pump-unloading function.

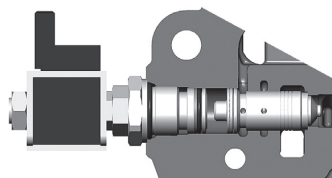

BEN – Electrically controlled pump-unloading function.

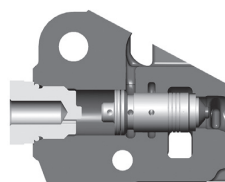

BX – Connection of signal pressure.

P22V variant pump unloading function

A267 Deutsch connector on the BEN magnet. Deutsch, type DT04-2P, mates with DT06-2S

A295 BEN function without manual emergency operation. AMP Junior-Timer, mates with type-C switch.

[P25] Tank connection T1

T1 Tank connection T1 is open.

T1B Tank connection T1 is plugged.

[P26] Pump connection P1

P1 Pump connection P1 is open.

P1B Pump connection P1 is plugged.

End section

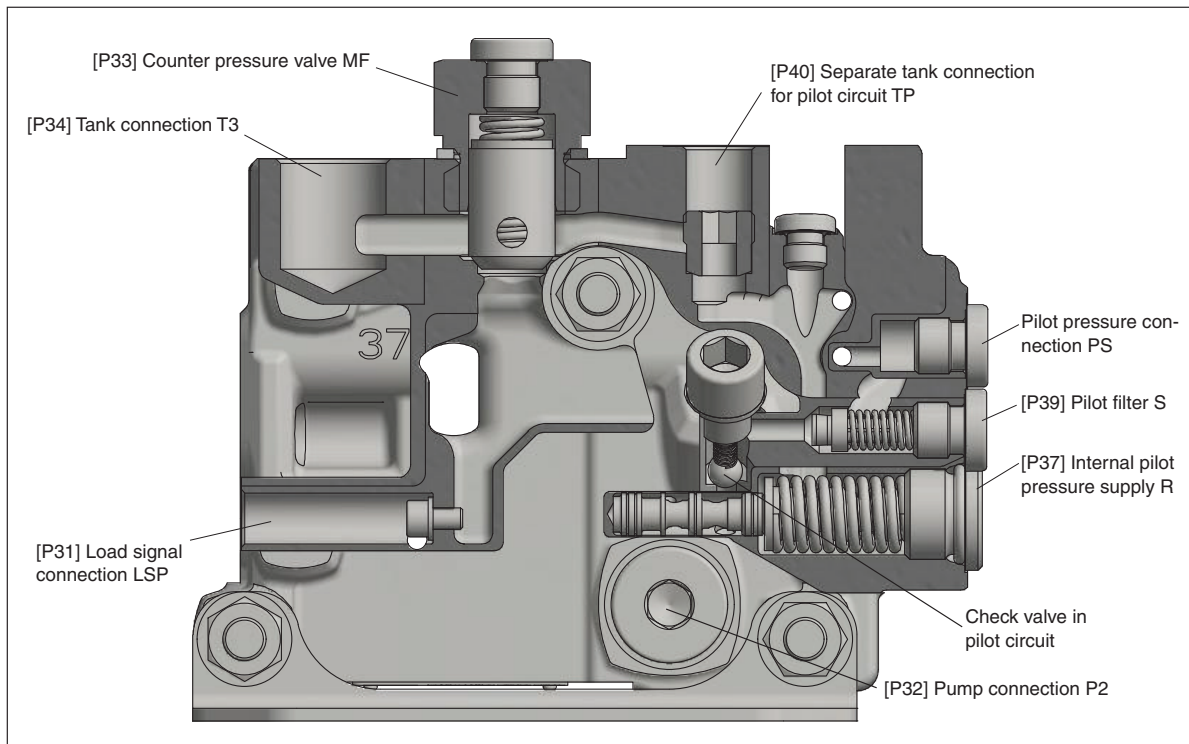

US End Section with pilot pressure supply, pilot filter, counter pressure valve and separate tank connection for pilot circuit.

[P30 - P44] End section

[P30] End section

US End section with the options pilot pressure supply and counter pressure function.

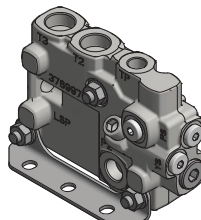

MU Combined work- and end section without possibility to have counter pressure function [P33], and pilot pressure supply [P37]. For more information about the options in the work section part of the MU, see chapter work section in the catalogue.

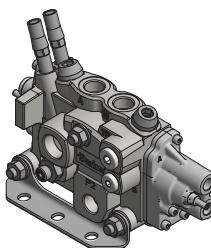

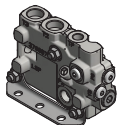
For end section [P30] US

[P31] LS connection

Possible option of connecting the load signal from several valves, parallel connection (the oil from the pump is divided in parallel to two or more valves).

LSP Port LSP is open.
Load signal from following valve must be received via the LSP port.

LSPB Port LSP is plugged (cannot receive load signal from following valve via LSP port).
Used in a one-valve system, and in the last valve in a system connected in parallel. (Can be converted into LSP function.)

[P32] Pump connection P2

P2 Pump connection P2 is open.

P2B Pump connection P2 is plugged.

[P33] Counter pressure valve / tank connection T2

Can either be used as a tank connection or fitted with a counterpressure valve. The counterpressure valve increases the pressure in the valve's tank gallery. By raising the counter pressure level the anti-cavitation characteristics of the L90LS are improved still further. Good make-up characteristics eliminate the risk of cavitation and reduce the risk of damage to the cylinder seals. Good make-up characteristic are also important for functions in which a lowering movement changes to a lifting movement without a time delay. For example, when an implement is lowered and then pressed down into the ground, or when a machine turns on sloping ground.

T2 Tank connection T2 is open.

T2B Tank connection T2 is plugged.

MF5 Counter pressure valve preset to give 5 bar counter pressure at a flow of 5 l/min.

A007 Counter pressure valve preset to give 5 bar counter pressure at a flow of 5 l/min. Also has built-in leakage for the counter pressure when no work section is activated.

/ Connection T2 not machined.

[P34] Tank connection T3

T3 Tank connection T3 is open.

T3B Tank connection T3 is plugged.

[P37] Internal-pilot pressure supply

Internal reducing valve for pilot pressure supply of the spool actuators.

Has a pressure relief valve to protect the pilot circuit, and a check valve to prevent oil from leaking back to the pump. Connection port "PS" is available for external use of the reduced pilot pressure; can also be used as measuring port for the reduced pilot pressure.

R22 Pressure setting reduced pressure 22 bar.

R28 Pressure setting reduced pressure 28 bar.

R35 Pressure setting reduced pressure 35 bar.

R43 Pressure setting reduced pressure 43 bar.

/ Valve without internal pilot-pressure supply.
There is a PS port for external supply of pilot pressure.

[P39] Pilot filter

S Strainer with bypass function in the internal pilot pressure supply. YS and PS ports can be used as a measuring port for reduced pilot pressure.

YS Blocks the connection between the internal pilot pressure supply and the spool actuators. The reduced pilot pressure can be accessed in the YS connection.

Normally used as the outlet for the internal pilot pressure supply to an external filter. The return oil from the filter is connected to PS port to supply the spool actuators.

/ Cavity for pilot filter not machined.

YS port available and has the same function as PS port (see [P37] /) but cannot be converted to option S or YS.

[P40] Tank connection for pilot circuit

TP Separate tank connection for the pilot circuit, port TP is open. The connection to the main tank gallery of the directional valve is blocked. The function is recommended for systems in which there is a risk of dynamic pressure fluctuations in the tank line, which can cause fluctuations in the pilot circuit when there is a common tank line. TP is recommended for electrohydraulic spool actuators.

TPB The tank return of the pilot circuit is connected to the tank gallery of the directional valve. Connection port TP is plugged. (Can be converted to TP).

/ TP port not machined.

The tank return of the pilot circuit is connected to the tank gallery of the directional valve.

End section

For end section [P30] MU

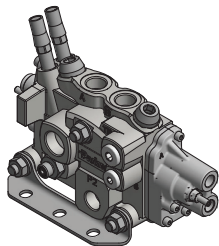

[P31] LS connection

LSP Port LSP is open.
Load signal from following valve must be received via the LSP port.

LSPX LSP port for load signal plugged, with no possibility of converting to LSP version.

/ LSP connection not machined.

[P32] Pump connection P2

P2 Pump connection P2 is open.

P2B Pump connection P2 is plugged.

/ P2 connection not machined.

[P33] Counter pressure valve / tank connection T2

End section [P30] MU does not have the possible option of a counterpressure valve.

T2 Tank connection T2 is open.

T2B Tank connection T2 is plugged.

/ T2 connection not machined.

[P37] Internal-pilot pressure supply

End section [P30] MU does not have the option of an internal reducing valve for the pilot pressure supply of the spool actuators.

PS Valve without internal pilot-pressure supply. PS port available for external pilot pressure feed to spool actuators.

/ Valve without internal pilot-pressure supply. No PS connection.

[P39] Pilot filter

/ Cavity for pilot filter not machined.

[P40] Tank connection for pilot circuit

TP Separate tank connection for the pilot circuit, port TP is open. The connection to the main tank gallery of the directional valve is blocked. The function is recommended for systems in which there is a risk of dynamic pressure fluctuations in the tank line, which can cause fluctuations in the pilot circuit when there is a common tank line. TP is recommended for electrohydraulic spool actuators.

TPX Separate tank connection for the pilot circuit. TP port is plugged. There is no internal connection in the section between the pilot circuit's tank and the valve's other tank.

/ TP connection not machined.
The section has no internal connection between the tank return of the pilot circuit and the valve's other tank.

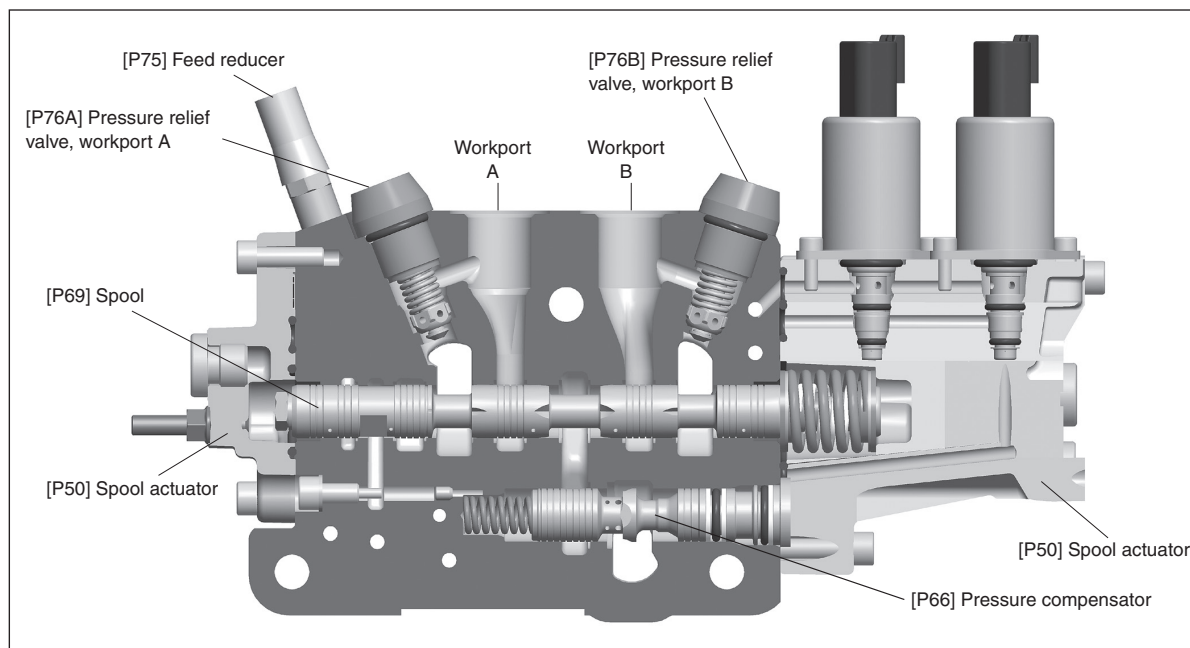
[P45-P89] Work section

The same valve may contain work sections with different types of spool actuators and compensators etc.
The max. number of work sections is normally 12.

[P47] Basic variants of work section

Work sections are available in different variants:

- OOO** Cavity for [P66] pressure compensator: Not machined.
Cavity for [P75] feed reducer: Not machined.
Cavity for [P76] pressure limitation valve: Not machined.
- TOO** Cavity for [P66] pressure compensator: Machined.
Cavity for [P75] feed reducer: Not machined.
Cavity for [P76] pressure limitation valve: Not machined.
- TAO** Cavity for [P66] pressure compensator: Machined.
Cavity for [P75] feed reducer: Machined for workport A.
Cavity for [P76] pressure limitation valve: Not machined.
- TBO** Cavity for [P66] pressure compensator: Machined.
Cavity for [P75] feed reducer: Machined for workport B.
Cavity for [P76] pressure limitation valve: Not machined.
- TCO** Cavity for [P66] pressure compensator: Machined.
Cavity for [P75] feed reducer: Machined for feeder reducer common to workports A and B.
Cavity for [P76] pressure limitation valve: Not machined.
- TTO** Cavity for [P66] pressure compensator: Machined.
Cavity for [P75] feed reducer: Machined for individual feeder reducer for either workport A or B.
Cavity for [P76] pressure limitation valve: Not machined.
- **T** All of the section variants above are available in versions that are machined for, and can be fitted with, port relief and/or anti-cavitation valves in workports A and B.
In such cases, the letter T is given in the third position in the product designation, e.g. OOT, TOT, TAT, TBT TCT and TTT.

Work section

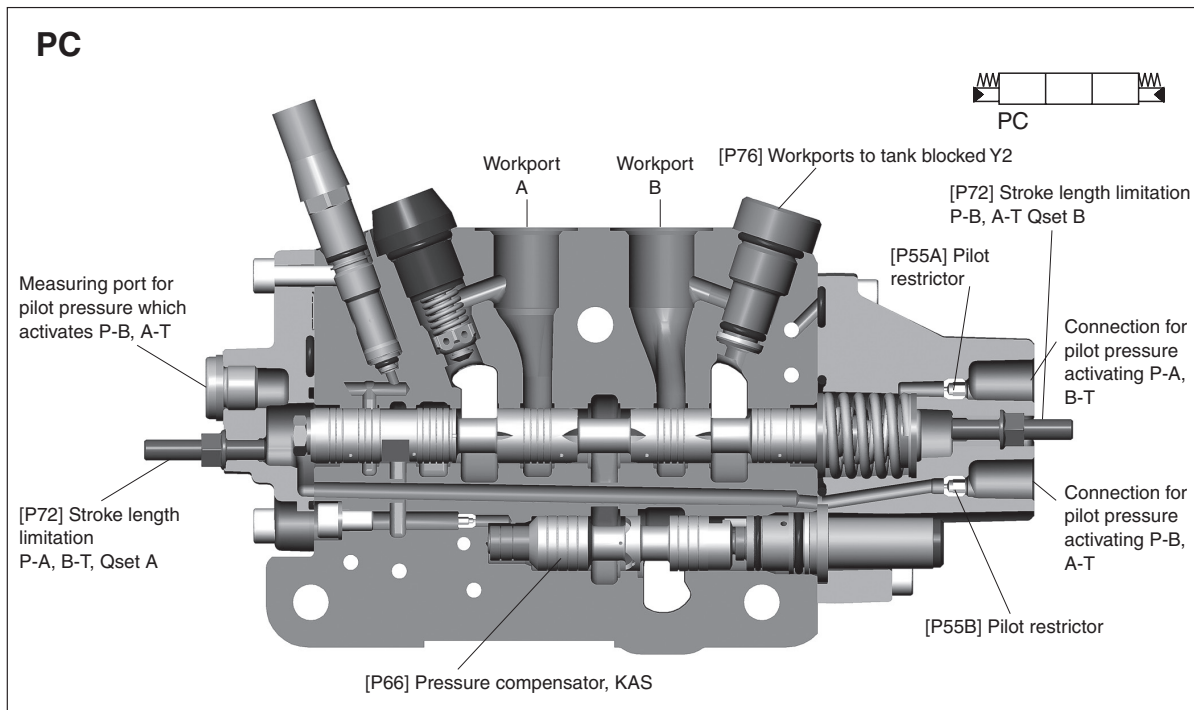

[P50] Spool actuators

Proportionally remote-controlled spool actuators, with enclosed spool-ends

PC Hydraulic spool actuator

The PC is a proportional, hydraulically controlled spool actuator with spring-centring to neutral. It is designed to be remote-controlled with a control pressure valve, for example type PCL4.

The pilot pressure for the control pressure valve can be tapped from the internal pilot pressure supply.
Control pressure, start: 5,5 bar
Control pressure, final: 15 bar
Permissible pressure in pilot cap max. 35 bar
Connections: G1/4 or 9/16-18 UNF

PC4 As PC, but with Parker [P53] spool position sensor.

PCH2 Hydraulic spool actuator with manual operation

As PC, but with the option of proportional control with hand lever.

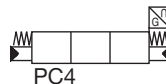
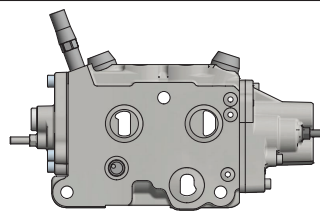

Symbol shows: [P50] PC4 + [P53] ARC

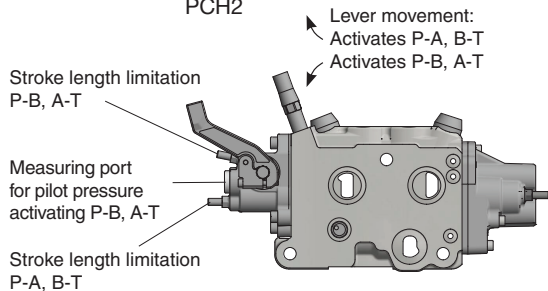
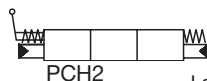
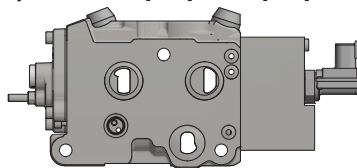

Work section

Proportionally remote-controlled spool actuators, with enclosed spool-ends

ECH3 Electro-hydraulic spool actuator with hand lever.

As ECS2, but with the option of proportional control with hand lever.

Spring force in neutral	60 N
Spring force for fully stroked spool	350 N
Other data the same as for ECS2 on previous page.	

ECHL3 Same as ECH3, only with a weaker centring spring. This can be used, for example, if the spool actuator often is used for manual control.

Spring force in neutral	85 N
Spring force for fully equipped slide	250 N

Control current for 12 V

Start current	min. 550 mA
Final current	max. 820 mA

Control current for 24 V

Start current	min. 260 mA
Final current	max. 440 mA

ECH4 As ECS2, but with Parker [P53] spool position sensor.

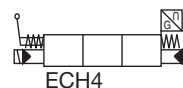
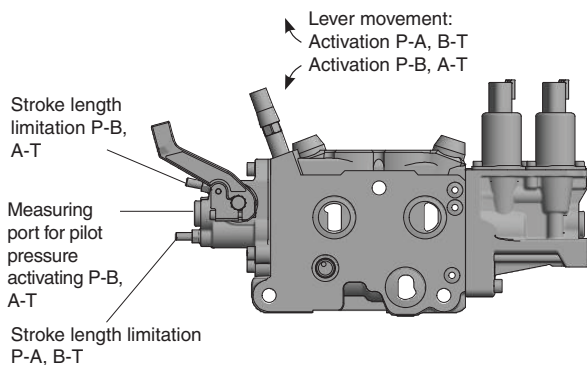

Symbol shows: [P50] ECH4 + [P53] ARC

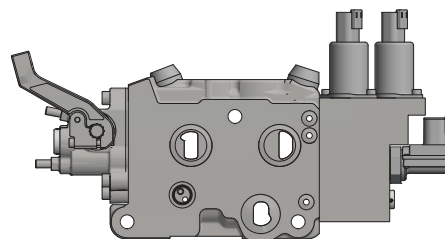

Manually controlled spool actuators, with enclosed spool-ends

CH2 Spring-centred spool actuator

CH2 is a spring-centred spool actuator with enclosed spool-ends for proportional operation with hand lever.

Spring force in neutral 70 N
Spring force for fully stroked spool 140 N



CHB32 3-position spool actuator

CHB32 is a spool actuator with a mechanical 3-position catch with enclosed spool-ends for operation by hand lever.

The spool actuator has three fixed positions: neutral position and fully actuated in either direction. Spool remains in selected position and must be moved deliberately from one position to another. Force needed on spool to overcome detent: approx. 160 N

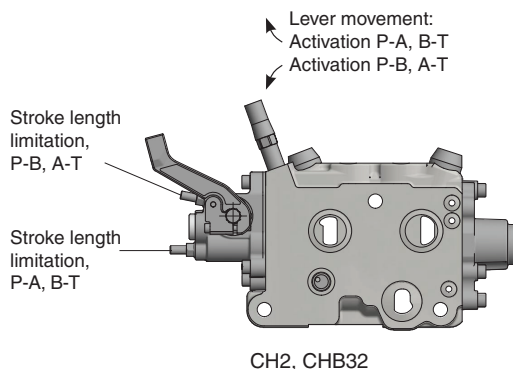

[P51] Lever bracket

Lever bracket for spool actuator with enclosed spool-end [P50] CH2, CHB32, ECH3, ECHL3, ECH4 and PCH2. The lever handle can be fitted at various angles. Lever bracket has M8 thread for optional fitting of a lever. Levers sold separately, see "Accessories".

L20-L28

Lever bracket fitted, selectable at various angles, see illustration.

LX Supplied without lever bracket

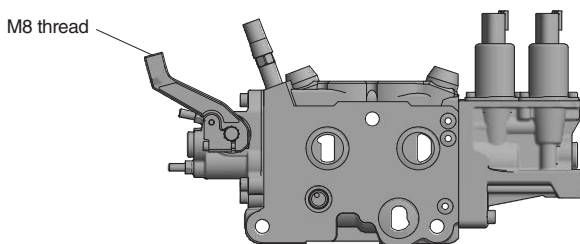

Example shows: [P51] L21

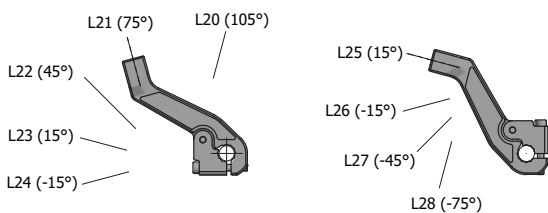

[P53] Spool position sensor

Parker spool position sensor for spool actuator [P50] ECS4, ECH4 and PC4. Can be chosen with an analog or digital output signal: Analog output signal which is proportional to the spool position. Digital output signal for indication when spool is inside or outside neutral position.

Connector DTM04-4P, mates with DTM06-4S.

- ARC** Analog output. Supply voltage 5 V
- ABC** Analog output. Supply voltage 6 V - 36 V
- DRC** Digital output. Supply voltage 5 V
- DBC** Digital output. Supply voltage 6 V - 36 V

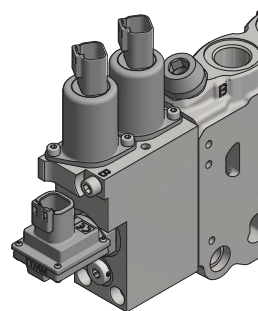

Work section

[P55A, B] Pilot restriction

To give gentle control characteristics, remote-controlled spool actuators with enclosed spool-ends are fitted with pilot restrictors, which can be chosen individually for each workport. The restrictor gives a kind of ramp function.

Restrictors from 0.6 to 2.0 mm are available. As standard 0,8 mm is recommended.

For EC2, ECS2, ECH3, ECHL3, ECS4 and ECH4 following options are available:

- 0.6 0.6 mm pilot restriction
- 0.7 0.7 mm pilot restriction
- 0.8 0.8 mm pilot restriction
- 0.9 0.9 mm pilot restriction.
- 1.0 1.0 mm pilot restriction
- 1.1 1,1 mm pilot restriction
- 1.2 1.2 mm pilot restriction
- 1.3 1.3 mm pilot restriction
- 1.5 1.5 mm pilot restriction
- 2.0 2.0 mm pilot restriction (No damping)

For PC, PCH2 and PC4, following options are available:

- / Without pilot restriction
- 0.6 0.6 mm pilot restriction
- 0.8 0.8 mm pilot restriction
- 0.9 0.9 mm pilot restriction.
- 1.0 1.0 mm pilot restriction
- 1.1 1.1 mm pilot restriction
- 1.2 1.2 mm pilot restriction
- 1.3 1.3 mm pilot restriction
- 1.4 1.4 mm pilot restriction.
- 1.5 1.5 mm pilot restriction

[P56] Connector type

The connector on the spool actuator is the following type:

- A AMP Junior-Timer, mates with type C.
- D Deutsch, type DT04-2P, mates with DT06-2S.

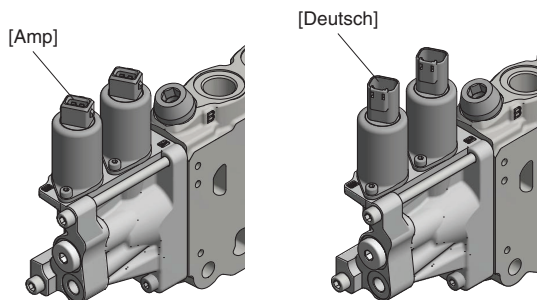

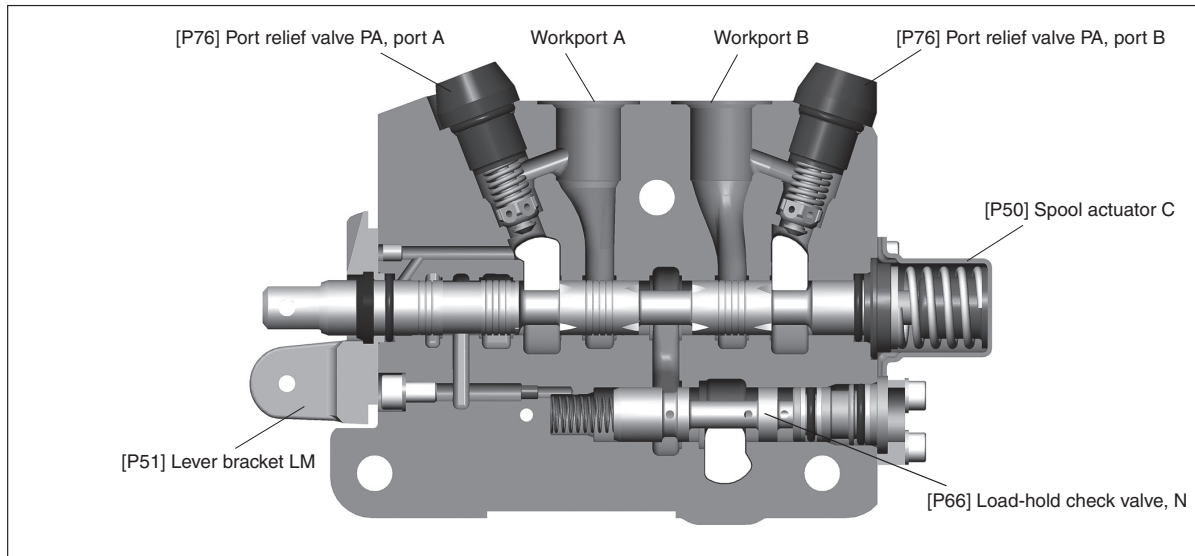

Manually actuated spool actuators with open spool-end

C Spring-centred spool actuator.
 Manually operated proportional spool actuator with spring centring to the neutral position.
 Spring force in neutral 60 N
 Spring force for fully stroked spool 130 N

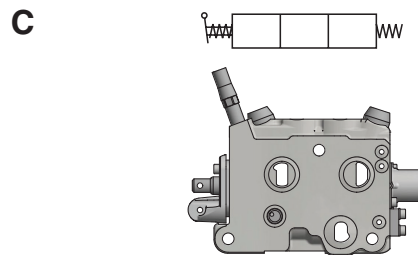

B3 3-position spool actuator.
 Equipped with 3-position mechanical detent that gives three fixed positions: neutral and fully actuated in either direction. Spool remains in selected position and must be moved deliberately from one position to another. Force needed on spool to overcome detent: approx. 160 N

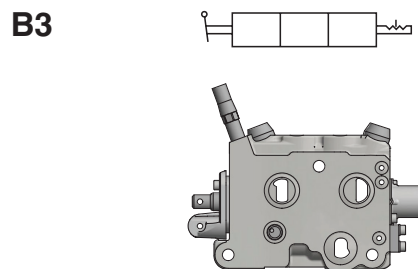

[P51] Lever bracket

LM Lever bracket for manually operated spools. Levers sold separately, see "Accessories".
LU Lever cover without lever bracket.
A053 Lever bracket LM rotated 180°.

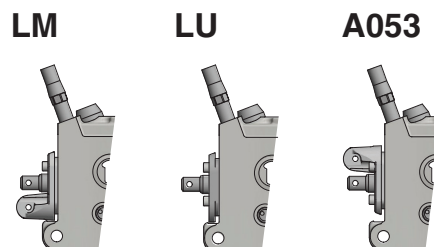

Spool in (→) activates P-B, A-T
 Spool out (←) activates P-A, B-T

Work section

The spool is the most important link between the operator's activation of a lever unit and the movement of the controlled function. For this reason, Parker makes a wide range of standard spools to meet many different function-specific demands. Spools are selected with the aid of a computerised configuration program based on a series of different parameters.

[P60] Spool function

There are many spool variants, customized for different flows, load conditions and actuator area ratios. The spools are also available with different degrees of force feedback [P64A, B]. The most commonly occurring spool functions are listed below.

D Double-acting spool for, e.g. double-acting cylinder.

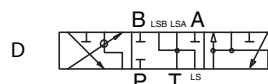

EA Single-acting spool for, e.g. single-acting cylinder. Raise and lower movement via workport A.

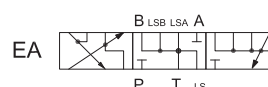

EB Single-acting spool for, e.g. single-acting cylinder. Raise and lower movement via workport B.

M Double-acting spool for, e.g. hydraulic motor. Float function in neutral position, connects workport A and B to tank.

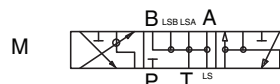

CA Regenerative spool for saving oil from the pump. The large side of the cylinder is connected to the A-port. Oil from workport B port is passed to workport A (and not to the tank) when activating P to A.

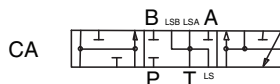

Dm Double-acting spool with drainage A to T and B to T, which prevents pressure build-up in workport in neutral position. The spool is used as a double-acting spool in combination with, e.g. an overcentre valve.

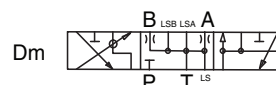

Da Double-acting spool with drainage A to T, which prevents pressure build-up in the A-port in the neutral position. The spool is used as a double-acting spool in combination with, e.g. an overcentre valve.

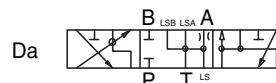

Db Double-acting spool with drainage B to T, which prevents pressure build-up in the B-port in the neutral position. The spool is used as a double-acting spool in combination with, e.g. an over-centre valve.

q (l/min) Flow rate in workport

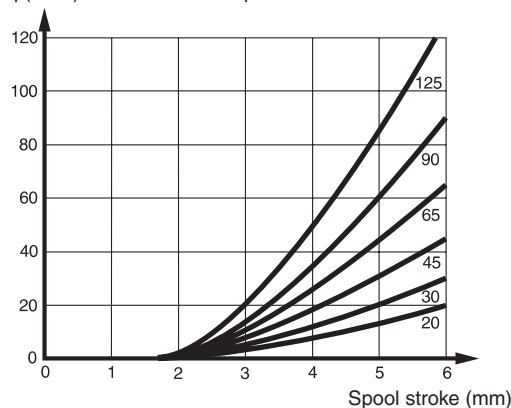

Typical curves showing flow to workport as function of spool stroke.



[P64A, B] Force feedback

The L90LS is available with a force feedback option in individual work sections and individual workports. With force feedback, the operator is better able to sense the increase in machine load, for example when a hard obstacle is met, and thereby avoid damage. Force feedback also gives a kind of ramp function, which results in more gentle transitions during speed changes. This results in a stabilizing effect on the hydraulic system, and the machine operating characteristics become smoother. Both these characteristics are important, especially for slewing functions and similar movements. With force feedback, machine wear is reduced and efficiency increases. The section can be equipped with force feedback for workports A and B, individually. The higher the level of force feedback is, the greater the reduction in the function's speed upon increasing pressure for the same lever stroke. It follows from this that the lever must be moved further in order for the speed of the function to remain the same.

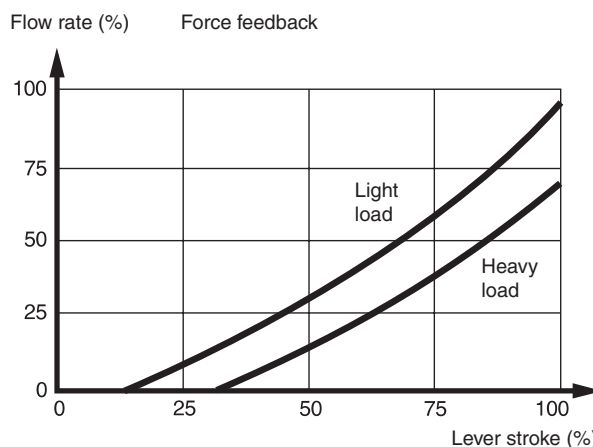

/ No force feedback.

FF Hydraulic force-feedback. The degree of force-feedback depends on the choice of pilot restrictors in [P55A, P55B]. The smaller the diameter of the pilot restrictor is, the greater the degree of force-feedback.

A027 Hydraulic force-feedback like FF, only with smaller diameter of restrictor in the spool.

FM Mechanical force-feedback on A-side. On B-side, some spools have the option of hydraulic force-feedback. Normal degree of force-feedback.

Force-feedback can only be obtained on valves which have hydraulic/electrohydraulic spool actuator [P50].

Work section
[P66] Pressure compensator / load-hold check valve

The primary purpose of pressure compensation is to maintain a constant flow rate to a function, regardless of pressure variations in the system.

The load-hold check valve prevents oil passing from the workport to the pump gallery if the pump pressure falls below the load pressure.

L90LS compensator types

L90LS can have two compensator types in the work sections: LS compensators, which provide a fixed, selectable pressure drop over the main spool. If the pump is overdemand, the flow from the section with the highest load pressure is reduced.

AS compensators, which provide a fixed, selectable pressure drop over the main spool based on ΔP over the valve. If the pump is overdemand, the flow is reduced with equal percentage for all actuated sections with AS compensators.

If a combination of LS and AS compensators is used, the flow is prioritised for the sections with LS compensators.

q (l/min) Flow rate curves

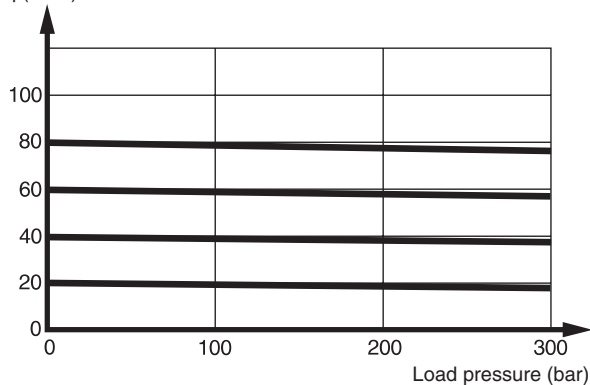

Load-independent flow with pressure compensator.

LS compensator types:

- /** Section not machined for pressure compensator or load-hold check valve.
- K** Fixed pressure compensator with load-hold check valve.
- KL** Fixed pressure compensator with load-hold check valve. Provides approx. 15% less flow than K.
- KH** Fixed pressure compensator with load-hold check valve. Provides approx. 20% more flow than K.
- KX** Fixed pressure compensator with load-hold check valve. Provides approx. 40% more flow than K.
- N** Only load-hold check valve, provides no pressure compensation.
- X** Section without compensator or load-hold check valve. Machined for retrofitting of pressure compensator or load-hold check valve.

AS compensator type:

- KAS** Compensator for systems with flow sharing. The flow to the workports, at a pressure difference of 20 bar between PX and LS, is roughly 40% more flow than K compensator.
- KAP** Compensator for systems with flow sharing. In principle, the KAP compensator works in the same way as the KAS. The difference is that there is an extra spring causing the pump to workport connection to close sooner than the KAS compensator, and sections with KAS compensators are given priority over sections with KAP compensators. Provides approx 5% more flow than K.

Work section

[P69] Spool designation

Spool selection is carried out using the configuration program for L90LS.

[P71A, B] Nominal flow to workport

Nominal flow to workport given by ΔP (PX-LS): 20 bar at [P66] KAS/KAP, 26 bar at [P66] KX, 15 bar at other compensators as well as N and X in [P66].

[P72] Flow settings

The strokes of spools controlled by enclosed spool-actuators can be limited to set the maximum flow to workport A and B.

/ No flow settings

Qset Limitation of max. flow in workports A and B.

Qset A Limitation of max. flow in workport A.

Qset B Limitation of max. flow in workport B.

[P72A] Desired setting flow

Desired flow for workport A is entered here.

[P72B] Desired setting flow

Desired flow for workport B is entered here.

[P75] Feed reducer valve

The L90LS with sections designated *A*, *B*, *C* or *T* at item [47] is equipped with feed-reducing valves.

Sections designated *A* have feed reduction in the A-port; Sections designated *B* have feed reduction in the B-port; those designated *C* have common feed reduction for the A-and B-ports; those designated *T* have individually adjustable feed reduction for the A-port and B-port.

Feed reduction is used for system functions that require a lower maximum pressure compared with the normal working pressure of the system. The feed reducer valve is a signal pressure limiter on the load signal.

The signal pressure limiter limits the pressure in the workport by causing the compensator spool to close the pump-workport connection when the signal pressure limiter reaches a preset value. This closes the flow and the function consumes a total of no more than 2 l/min, thereby limiting the pressure with minimal flow/energy loss.

The feed reducer valve cannot handle external pressure peaks, so if they occur, it is recommended to use pressure relief valves in [P76A, B].

The set pressure in the feed reducer is adjustable.

The set pressure is specified in the relevant workport [P75A], [P75B].

To disable the feed reducer function, select "MAX" in [P75AM], [P75BM]

[P75A] Setting of feed reduction in the A-port

Pressure setting for workport A selectable from 25 to 330 bar.

[P75B] Setting of feed reduction in the B-port

Pressure setting for workport B selectable from 25 to 330 bar.

q_m (l/min) Feed reduction characteristics

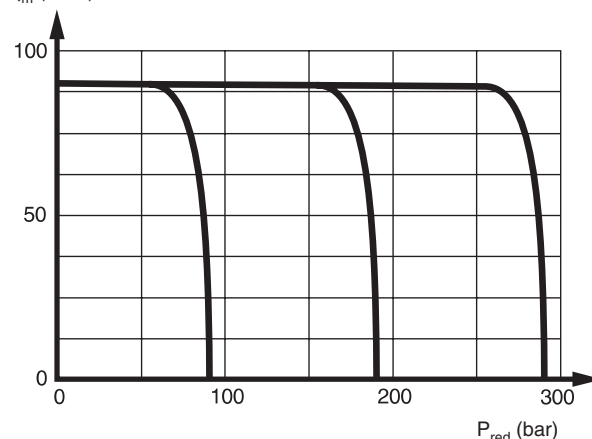

P_{red} = reduced pressure
 q_m = flow rate in workport

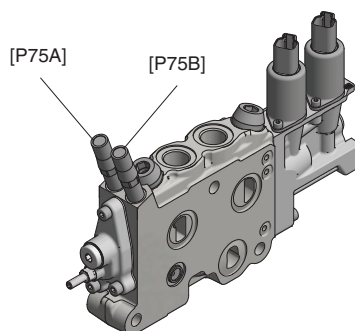

Work section

[P76A, B] Port relief and/or anti-cavitation valves

/ Section not machined for port relief valves.

In sections designated **T [P47], the selection below can be made:

- X2** Workport open to tank.
- Y2** Connection workport to tank blocked with plug.
- N2** Workports of section equipped with anti-cavitation valve. In the event of negative pressure in the workports, the anti-cavitation function allows oil to flow from the tank channel to the workport.
- PA** Pressure limitation valve with anti-cavitation function for workport. In the event of negative pressure in the workports, the anti-cavitation function allows oil to flow from the tank channel to the workport. Selectable pressure settings in bar: 32, 50, 63, 80, 100, 125, 140, 160, 175, 190, 210, 230, 240, 250, 260, 270, 280, 300, 320, 350, 380, 400 and 420.

Δp (bar) PA, pressure relief characteristics

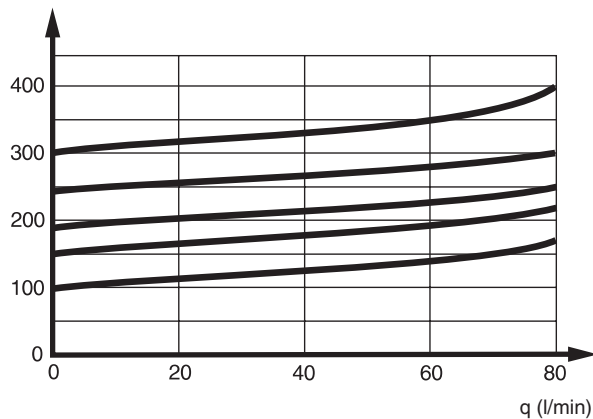

Δp (bar) Anti-cavitation characteristics

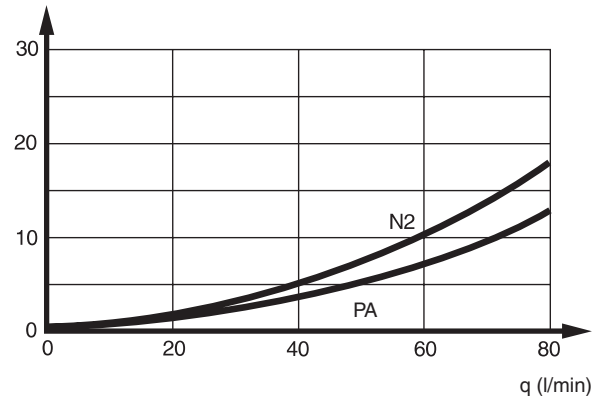

Work section

System functions

The L90LS can be equipped with integrated functions to create complete system solutions. The load signal from any workport or work section can be connected with signal channels and utilized to stop or limit the pressure to individual machine functions.

[P80] System signal lines

- SF** Valve section equipped with 3 signal lines / channels that can be connected internally to individual load signals [P81] from workport.
- /** No signal lines.

[P81] Individual LS connection

- /** No LS connection to signal lines. No possibility of external connection either.
- A1B** Load signal from port A connected to channel 1.
- A1B1** Load signal from both port A and B connected to channel 1.
- A1B2** Load signal from port A connected to channel 1. Load signal from port B connected to channel 2.
- A1B3** Load signal from port A connected to channel 1. Load signal from port B connected to channel 3.
- A2B** Load signal from port A connected to channel 2.
- A2B2** Load signal from both port A and B connected to channel 2.
- A2B3** Load signal from port A connected to channel 2. Load signal from port B connected to channel 3.
- A3B3** Load signal from both port A and B connected to channel 3.
- AB** No connection between load signal and signal channels.
- AB2** Load signal from port B connected to channel 2.
- AB3** Load signal from port B connected to channel 3.

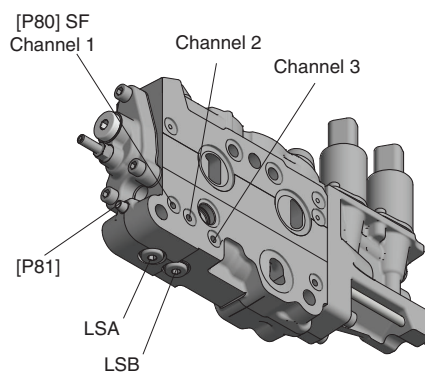

The load signal from more than one section can be connected to the same channel. A check valve in each section prevents reverse flow of the load signal from the channels into individual sections. In addition to connection with the signal channels, the load signal is also available for external connection at ports LSA and LSB.

Work section

[P85] Internal connection of workport

Internal connection between workports to nearby sections or function manifold.

The diameter of the side port connection is 8.5 mm; thus it is not a full-flow connection. The aim is to pressure-equalize sections controlled in parallel, or to transfer a signal to a manifold.

- / No internal workport connection.
- M Gives internal workport connection downstream of the work section.
- M2 Gives internal service-port connection both downstream and upstream of the work section.

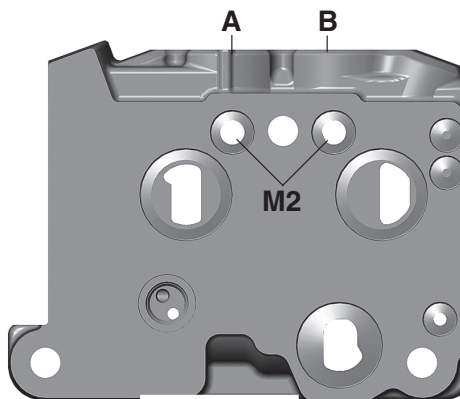

Worksection with internal connection of workports, M2.

[P89A, B] Variant workport

- A034 Cavity plug instead of the solenoid valve at EC2, ECS2, ECH3, ECHL3, ECS4, ECH4 in [P50].

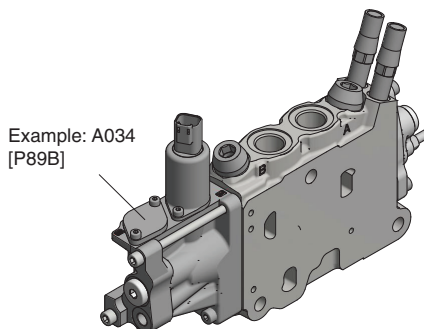

[P90-99] Function manifolds

The L90LS can be equipped with function manifolds that enable complete system solutions to be integrated into the valve. Contact Parker for integral system solutions. Some of our function manifolds are described below:

M12 Function manifold with float function for preceding work section.

The workports in the section can be connected to the tank via an electric on-off valve, independently of the spool position. This can be done individually for workport A or B or for both workports. The on-off valves can be selected as normally closed or normally open, and if a workport will never be connected to the tank via the manifold, a cavity plug is selected. The preceding work section must have a side port connection M [P85]. Pressure drop approx 30 bar at 100 lpm.

M14 Function manifold for controlling pressure in preceding work section.

This manifold can control the pressure in the workports in preceding work section to a variable level lower than any feed reducing valve [P75]. This is done by using an electric proportional relief valve in the load signal channel. Depending on the configuration, the pressure can be controlled separately for each workport or jointly to pressure levels between 20 and 285 bar. You can choose whether the pressure control is connected all the time or is switchable using an electrically controlled on-off valve. The manifold must be placed after a work section with side port connection, M [P85].

The sections must also contain individual LS connections [P81]. The system signal channel, SF [P80] no. 2, connects the manifold with the work section.

M15 Function manifold for pump channel division between inlet and end section.

This manifold separates the pump and load signal channel from the inlet and end section. Preceding sections are supplied with pump oil and pressure relief via the inlet section. In the following sections, pressure relief is via a fixed pressure relief valve in the M15 manifold, and pump oil is supplied from the end section. Load signals for the pump are taken from the inlet section to the preceding work sections and from the M15 manifold to the following work sections.

M16 Function manifold controlling the pressure in the preceding and following work sections.

This manifold can control the pressure in the workports in adjacent work sections to a variable level lower than any feed reducing valve [P75]. The pressure in the preceding work section can be controlled in workport A, and the pressure in the following work section can be controlled in workport B. This is done using variable electrically controlled pressure relief valves in the load signal channels. The pressure level can be set between 20 and 285 bar. The manifold is placed between two work sections containing side port connections M and M2 [P85]. The sections must also contain individual LS connections [P81]. The system signal channel, SF [P80] no. 1, connects the manifold with the preceding sections and system signal channel no. 3 connects the following sections.

M17 Function manifold for draining the workports in sections placed side by side.

The preceding work sections must contain side port connections M [P85] and the following work sections may contain side port connections M2 [P85] if draining is required there. Drainage to the tank is done by an electrically controlled valve. When the valve is closed, there is no leakage between the workports due to integrated check valves in the manifold. Maximum drainage flow per workport is 10 [l/min].

Accessories

Connectors, hand levers etc. are accessories. These are ordered separately. See our accessories catalogue (HY17-8558/UK).



[P50] EC2 manual override

Manual override may not be used without knowledge of functionality.

CAUTION: No proportional function



1. A special tool must be used to engage the manual override function of the solenoid! Use of other tools to attempt to engage or disengage the manual override may not work or may not work when intended.
2. When using the manual override function, the solenoid has only on-off functionality and doesn't operate proportionally as usual. This means, for example, that the solenoid may operate much faster than usual and the unexpected speed could cause crushing or other injuries.
3. When using the manual override be certain that all operations of the application, regardless of speed, will not endanger persons or property nearby.
4. As always, consult the operations manual for all specifications and functions of the valve. If there are questions contact MSDE.

The PS25MO is equipped with a manual override pin in the connector. To actuate the PS25MO a specific tool is needed since the tolerances of the pin is so small that it can be damaged or the pin sticks in actuated position.

Please notify that it's for fault searching only and shall be used as rarely as possible with common sense in mind. If manual override is used humans can be exposed for very dangerous situations. Please read the legal limits before using the manual override.

Part number for override tool: 6763001.

Spare parts

Parker's configuration program for L90LS has a Spare parts list available for the current configuration.

An example is shown below:

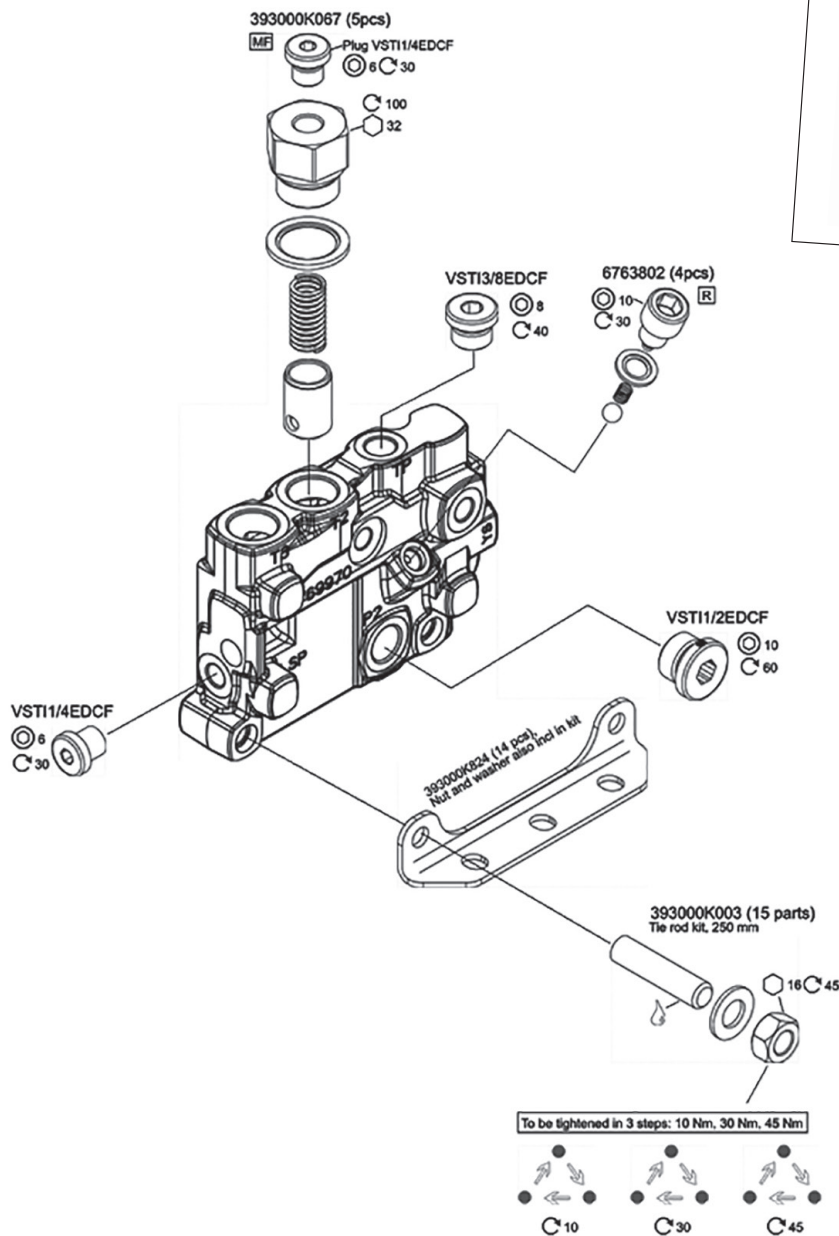

Parker Worldwide

Europe, Middle East, Africa

AE – United Arab Emirates, Dubai
Tel: +971 4 8127100
parker.me@parker.com

AT – Austria, St. Florian
Tel: +43 (0)7224 66201
parker.austria@parker.com

AZ – Azerbaijan, Baku
Tel: +994 50 2233 458
parker.azerbaijan@parker.com

BE/NL/LU – Benelux, Hendrik Ido Ambacht
Tel: +31 (0)541 585 000
parker.nl@parker.com

BG – Bulgaria, Sofia
Tel: +359 2 980 1344
parker.bulgaria@parker.com

BY – Belarus, Minsk
Tel: +48 (0)22 573 24 00
parker.poland@parker.com

CH – Switzerland, Etoy
Tel: +41 (0)21 821 87 00
parker.switzerland@parker.com

CZ – Czech Republic, Klecany
Tel: +420 284 083 111
parker.czechrepublic@parker.com

DE – Germany, Kaarst
Tel: +49 (0)2131 4016 0
parker.germany@parker.com

DK – Denmark, Ballerup
Tel: +45 43 56 04 00
parker.denmark@parker.com

ES – Spain, Madrid
Tel: +34 902 330 001
parker.spain@parker.com

FI – Finland, Vantaa
Tel: +358 (0)20 753 2500
parker.finland@parker.com

FR – France, Contamine s/Arve
Tel: +33 (0)4 50 25 80 25
parker.france@parker.com

GR – Greece, Piraeus
Tel: +30 210 933 6450
parker.greece@parker.com

HU – Hungary, Budaörs
Tel: +36 23 885 470
parker.hungary@parker.com

IE – Ireland, Dublin
Tel: +353 (0)1 466 6370
parker.ireland@parker.com

IL – Israel
Tel: +39 02 45 19 21
parker.israel@parker.com

IT – Italy, Corsico (MI)
Tel: +39 02 45 19 21
parker.italy@parker.com

KZ – Kazakhstan, Almaty
Tel: +7 7273 561 000
parker.easteurope@parker.com

NO – Norway, Asker
Tel: +47 66 75 34 00
parker.norway@parker.com

PL – Poland, Warsaw
Tel: +48 (0)22 573 24 00
parker.poland@parker.com

PT – Portugal
Tel: +351 22 999 7360
parker.portugal@parker.com

RO – Romania, Bucharest
Tel: +40 21 252 1382
parker.romania@parker.com

RU – Russia, Moscow
Tel: +7 495 645-2156
parker.russia@parker.com

SE – Sweden, Borås
Tel: +46 (0)8 59 79 50 00
parker.sweden@parker.com

SK – Slovakia, Banská Bystrica
Tel: +421 484 162 252
parker.slovakia@parker.com

SL – Slovenia, Novo Mesto
Tel: +386 7 337 6650
parker.slovenia@parker.com

TR – Turkey, Istanbul
Tel: +90 216 4997081
parker.turkey@parker.com

UA – Ukraine, Kiev
Tel: +48 (0)22 573 24 00
parker.poland@parker.com

UK – United Kingdom, Warwick
Tel: +44 (0)1926 317 878
parker.uk@parker.com

ZA – South Africa, Kempton Park
Tel: +27 (0)11 961 0700
parker.southafrica@parker.com

North America

CA – Canada, Milton, Ontario
Tel: +1 905 693 3000

US – USA, Cleveland
Tel: +1 216 896 3000

Asia Pacific

AU – Australia, Castle Hill
Tel: +61 (0)2-9634 7777

CN – China, Shanghai
Tel: +86 21 2899 5000

HK – Hong Kong
Tel: +852 2428 8008

IN – India, Mumbai
Tel: +91 22 6513 7081-85

JP – Japan, Tokyo
Tel: +81 (0)3 6408 3901

KR – South Korea, Seoul
Tel: +82 2 559 0400

MY – Malaysia, Shah Alam
Tel: +60 3 7849 0800

NZ – New Zealand, Mt Wellington
Tel: +64 9 574 1744

SG – Singapore
Tel: +65 6887 6300

TH – Thailand, Bangkok
Tel: +662 186 7000

TW – Taiwan, Taipei
Tel: +886 2 2298 8987

South America

AR – Argentina, Buenos Aires
Tel: +54 3327 44 4129

BR – Brazil, Sao Jose dos Campos
Tel: +55 800 727 5374

CL – Chile, Santiago
Tel: +56 2 623 1216

MX – Mexico, Toluca
Tel: +52 72 2275 4200



EMEA Product Information Centre

Free phone: 00 800 27 27 5374

(from AT, BE, CH, CZ, DE, DK, EE, ES, FI, FR, IE, IL, IS, IT, LU, MT, NL, NO, PL, PT, RU, SE, SK, UK, ZA)

US Product Information Centre

Toll-free number: 1-800-27 27 537

www.parker.com

Your local authorized Parker distributor