

Accumulator & Cooler Distributor Catalogue



ENGINEERING YOUR SUCCESS.

Accumulator and Cooler Division Europe

Made in Europe - serving all markets and industries

Parker Wrocław

(Wrocław, Poland)

Products:

Coolers (All coolers)
Piston Accumulators (ACP, A, AP)

Market Focus:

Industrial, Mobile, Energy



Parker ACDE Sandycroft

(Chester, UK)

Products:

Bladder Accumulators & Accessories (UK, O&G)
Piston Accumulators (EHP)
Pulsation Dampers, Hydracushions, Compensators

Market Focus:

Oil and Gas, Industrial



Parker ACDE Paris

(Colombes, France)

Products:

Bladder Accumulators & Accessories (EBV, EHV)
Diaphragm Accumulators (DA)
Attenuators

Market Focus:

Wind Power, Industrial, Aerospace, Motor Sport



Parker ACDE Turin

(Turin, Italy)

Products:

Bladder Accumulators & Accessories (EBV, EHV)
Piston Accumulators (EHP)
Gas Bottles, Accumulator Systems

Market Focus:

Oil and Gas, Industrial

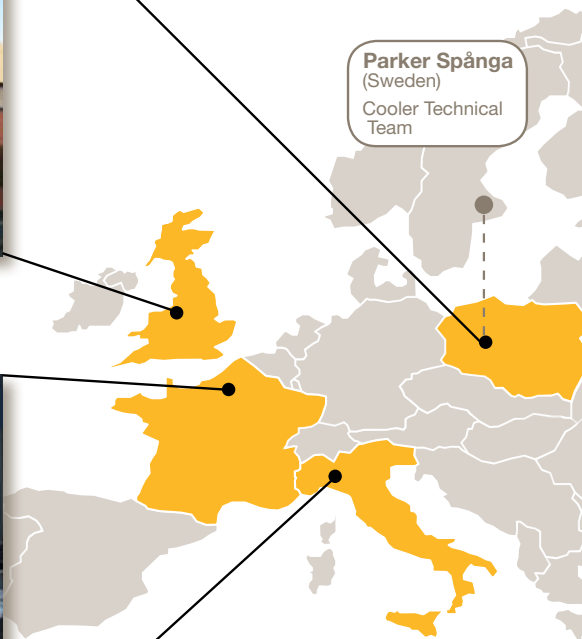

Contents

ACCUMULATORS

Bladder Accumulators

EHV Series Bladder Accumulators	6
EHV Spare Parts/ Bladder Kit	10
Accumulator Set - bladder accumulator + clamp + bracket + safety block	11
Global Bladder Accumulator - SELO + ASME+ CE approvals	12

Piston Accumulators

Crimped Piston Accumulator - ACP Series	13
---	----

Diaphragm Accumulators

DA Series - Diaphragm Accumulators	14
------------------------------------	----

Accessories

Clamps & Brackets	16
Charging Sets	17
Safety Blocks	18
Pressure Relief Valve Block	19
Adaptors	20
Gas Bottles	21

How to size an accumulator

	22
--	----

COOLERS

Air Oil Coolers

Air Oil Coolers with AC Motor - LAC Series	24
Air Oil Coolers with DC Motor - LDC Series	26
Air Oil Coolers with AC Motor & Pump - LOC Series	28

Water Oil Coolers

Brazed Plate Water Oil Cooler - PWO Series	30
Shell & Tube Water Oil Cooler - SWO Series	31

Pumps

Gerotor Pump - QPM3 Series	32
----------------------------	----

How to Size a Cooler	33
-----------------------------	-----------

Online Support	34
-----------------------	-----------

User Guide

The Distribution Catalogue only contains standard product and has been specially developed for Parker Distributors in Europe, Middle East and Africa.

A more extensive range of products for use in all countries, as well as other industry specific approvals is available on the Parker website and within product catalogues.

This catalogue is an extract of the main accumulator catalogue (HY10-4004) and the cooler catalogues.

www.parker.com/acde

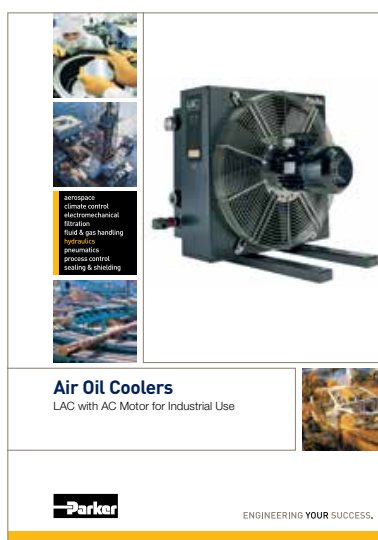

PARKER SAFETY GUIDE FOR SELECTING AND USING ACCUMULATORS AND COOLERS AND RELATED ACCESSORIES

WARNING

FAILURE OR IMPROPER SELECTION OR IMPROPER USE OF THE PRODUCTS AND/OR SYSTEMS DESCRIBED HEREIN OR RELATED ITEMS CAN CAUSE DEATH, PERSONAL INJURY AND PROPERTY DAMAGE.

This document and other information from Parker Hannifin Corporation, its subsidiaries and authorized distributors provide product and/or system options for further investigation by users having expertise. It is important that you analyze all aspects of your application, including consequences of any failure and review the information concerning the product or system in the current product catalogue. Due to the variety of operating conditions and applications for these products or systems, the user, through its own analysis and testing, is solely responsible for making the final selection of the products and systems and assuring that all performance, safety and warning requirements of the application are met.

The products described herein, including without limitation, product features, specifications, designs, availability and pricing, are subject to change by Parker Hannifin Corporation and its related companies at any time without notice.



2 day
dispatch

Accumulators

Bladder, Piston & Diaphragm Accumulators
and Accessories



Bladder Accumulator EHV Series - C & D gas valve

The EHV bladder accumulator is designed for high pressure hydraulic systems.

- Standard version (Carbon Steel shell/NBR mix) compatible with mineral oils.
- According to PED 2014/68/EU, EN 14359, Fluid Group 2.
- A wider range of products (material, pressure, design, regulation, connection and other options) and more technical information is available on the Parker website and in the Accumulator Catalogue.

Part number	Type	Valve	Clamps	Support Bracket	Effective Gas volume Litres	Max. Working pressure (PS) bar	Admissible Accumulator Temperature min/max (°C)	Weight kg	Dimensions in mm			Seal O-ring
			Model (quantity) Part number	Model Part number					A max Height	øD	G	
10876301120	EHV 0.2-350/00-A20AD-200*	D	A56 (1) 20149203625		0.17	350	- 6/+80	2.5	268	58	G ½"	18x2
10876401125	EHV 0.5-350/00-A25BD-200*	D	E95 (1) 20250803648		0.6	350	- 20/+80	3	260	91	G ¾"	21,3x2,4
10845601125	EHV 1-350/00-A25BC-200*	C	E114 (1) 20251003648	CE 89 20151903620	1	350	- 20/+80	6	330	116	G ¾"	21,3x2,4
10998301125	EHV 1.6-350/90-A25BC-200	C	E114 (1) 20251003648	CE 89 20151903620	1.6	350	- 20/+80	8	442	116	G ¾"	21,3x2,4
10854701125	EHV 2.5-350/90-A25DC-200	C	E114 (2) 20251003648	CE 89 20151903620	2	350	- 20/+80	11	549	116	G 1 ¼"	36,2x3
10845401125	EHV 4-350/90-A25DC-200	C	E168 (1) 20251303648	CE108 20118703620	3.7	350	- 20/+80	15	434	170	G 1 ¼"	36,2x3
10861201125	EHV 5-350/90-A25DC-200	C	E114 (2) 20251003648	CE 89 20151903620	5	350	- 20/+80	17	898	116	G 1 ¼"	36,2x3
10857401125	EHV 6-350/90-A25DC-200	C	E168 (2) 20251303648	CE108 20118703620	6.0	350	- 20/+80	20	560	170	G 1 ¼"	36,2x3
10859701125	EHV 10-350/90-A25DC-200	C	E168 (2) 20251303648	CE108 20118703620	10	350	- 20/+80	31	825	170	G 1 ¼"	36,2x3

* According to Article 4.3 PED 2014/68/EU

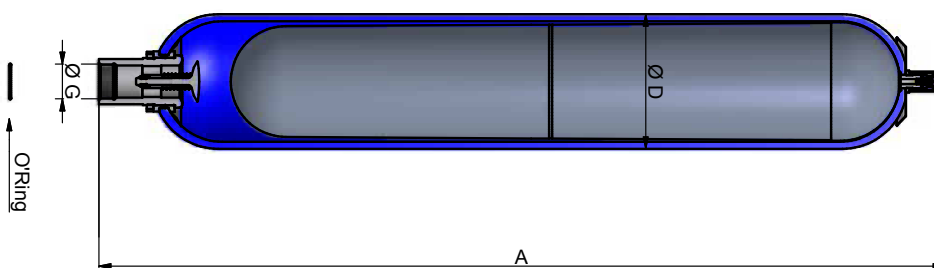

Model of valve stem integrated
7/8" 14 UNF
(C)



Model of valve stem integrated
5/8" 18 UNF
(D)



Bladder Accumulator EHV Series- A gas valve

The EHV bladder accumulator is designed for high pressure hydraulic systems.

- Standard version (Carbon Steel shell/NBR mix) compatible with mineral oils.
- According to PED 2014/68/EU, EN 14359, Fluid Group 2.
- A wider range of products (material, pressure, design, regulation, connection and other options) and more technical information is available on the Parker website and in the Accumulator Catalogue.

Part number	Type	Valve	Clamps	Support Bracket	Effective Gas volume Litres	Max. Working pressure (PS) bar	Admissible Accumulator Temperature min/max (°C)	Weight kg	Dimensions in mm			Seal O-ring
			Model (quantity) Part number	Model Part number					A max Height	øD	G	
10837001125	EHV 10-330/90-A25GA-200	A	D226 (2) 20251503648	CE159A 20109003620	9.2	330	-20/+80	31	587	226	G2"	54x3
10867101125	EHV 12-330/90-A25GA-200	A	D226 (2) 20251503648	CE159A 20109003620	11	330	-20/+80	36	687	226	G2"	54x3
10837101125	EHV 20-330/90-A25GA-200	A	D226 (2) 20251503648	CE159A 20109003620	17.8	330	-20/+80	49	897	226	G2"	54x3
10837201125	EHV 24,5-330/90-A25GA-200	A	D226 (2) 20251503648	CE159A 20109003620	22.5	330	-20/+80	56	1032	226	G2"	54x3
10837301125	EHV 32-330/90-A25GA-200	A	D226 (2) 20251503648	CE159A 20109003620	32	330	-20/+80	81	1420	226	G2"	54x3
11076701125	EHV 50-330/90-A25GA-200	A	D226 (2) 20251503648	CE159A 20109003620	48.5	330	-20/+80	110	1936	226	G2"	54x3

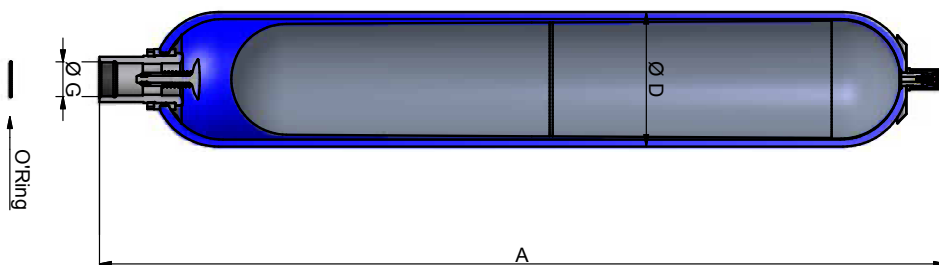

Model of valve stem
5/8" 18 UNF
(A)



2 day dispatch
Max Pre-charge
150 bar
Max qty
5 units



Bladder Accumulator EHV Series - B gas valve

The EHV bladder accumulator is designed for high pressure hydraulic systems.

- Standard version (Carbon Steel shell/NBR mix) compatible with mineral oils.
- According to PED 2014/68/EU, EN 14359, Fluid Group 2.
- A wider range of products (material, pressure, design, regulation, connection and other options) and more technical information is available on the Parker website and in the Accumulator Catalogue.

Part number	Type	Valve	Clamps	Support Bracket	Effective Gas volume Litres	Max. Working pressure (PS) bar	Admissible Accumulator Temperature min/max (°C)	Weight kg	Dimensions in mm			Seal O-ring
			Model (quantity) Part number	Model Part number					A max Height	øD	G	
10866901125	EHV 1-350/00-A25BB-200*	B	E114 (1) 20251003648	CE 89 20151903620	1	350	-20/+80	6	330	116	G ¾"	21,3x2,4
10866101125	EHV 4-350/90-A25DB-200	B	E168 (1) 20251303648	CE108 20118703620	3.7	350	-20/+80	15	434	170	G 1 ¼"	36,2x3
10865401125	EHV 10-330/90-A25GB-200	B	D226 (2) 20251503648	CE159A 20109003620	9.2	330	-20/+80	31	587	226	G2"	54x3
10865501125	EHV 20-330/90-A25GB-200	B	D226 (2) 20251503648	CE159A 20109003620	17.8	330	-20/+80	49	897	226	G2"	54x3
10865701125	EHV 32-330/90-A25GB-200	B	D226 (2) 20251503648	CE159A 20109003620	32	330	-20/+80	81	1420	226	G2"	54x3
11076801125	EHV 50-330/90-A25GB-200	B	D226 (2) 20251503648	CE159A 20109003620	48.5	330	-20/+80	110	1936	226	G2"	54x3

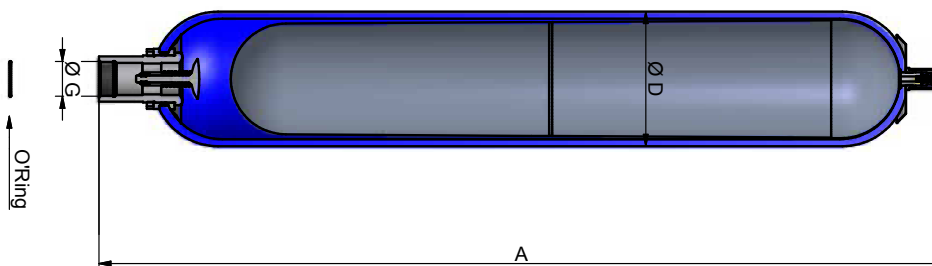

Model of valve stem
 7/8" 14 UNF
 (B)



Bladder Accumulator UK Series - F gas valve

Standard version (Carbon Steel shell/NBR mix) compatible with mineral oils.

According to PED 2014/68/EU, AD2000, Fluid Group 2

Fluid Port Seal Arrangement - Bonded Seal Type

- A wider range of products (material, pressure, design, regulation, connection and other options) and more technical information is available on the Parker website and in the Accumulator Catalogue.

Part number	Valve	Clamps	Support Bracket	Effective Gas volume Litres	Max. Working pressure (PS) bar	Admissible Accumulator Temperature min/max (°C)	Weight kg	Dimensions in mm			Bonded Seal (BS Standard)
		Part number	Model Part number					A max Height	øD	G	
01100A-00-341	F**	10981	NA	1	345	-15°C to +80°C	5.7	292	115	G 3/4"	G 3/4"
0300A-00-341	F**	10981	NA	2.5	345	-15°C to +80°C	10	506	115	G 1"	G 1"
0400A-00-341	F	10982-DEE	10962-DEE	4	345	-15°C to +80°C	15.2	455	169	G 1 1/4"	G 1 1/4"
1000A-00-341	F	10983	10961	10	345	-15°C to +80°C	35	575	230	G 2"	G 2"
2000A-00-341	F	10983	10961	20	345	-15°C to +80°C	55	886	230	G 2"	G 2"
3700A-00-341	F	10983	10961	37	345	-15°C to +80°C	91	1407	230	G 2"	G 2"
5400A-00-341	F	10983	10961	54	345	-15°C to +80°C	130	1922	230	G 2"	G 2"

** Integrated gas valve

Clamps are 316 stainless steel

Brackets are carbon steel

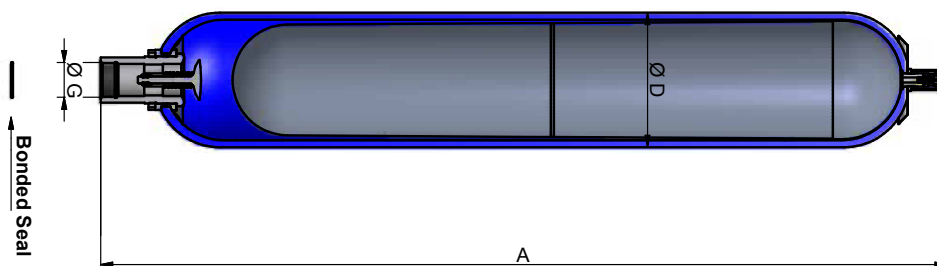

Model of valve stem
1/4"
(F)



Spare Parts

Item	Spare parts	Item	Spare parts
1	Spare Parts Kit	7*	Spacer
2	Valve nut	8*	Locking nut
3	Gas valve Assembly	9	O-ring fluid port
3.1	Gas valve	10	Back up ring (depending on the model)
3.2	Gas valve plug	11	Bladder
4	Anti-extrusion ring		
5	Fluid port seal		
6	Back up seal ring		

* These parts are not delivered in the spare parts kit (complete repair kit)

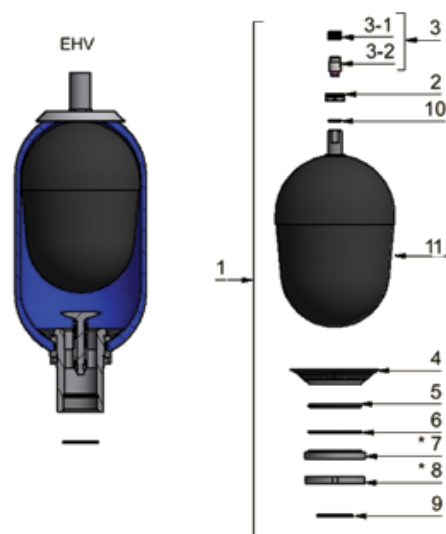

Bladder Kit

Parker Olaer offer genuine parts for the maintenance of hydraulic accumulators.

- A wider range of products and more technical information is available on the Parker website and in the Accumulator Catalogue.

Part Number	Type	Accumulator Volume	Ø Stem Valve	Gas Valve Type
19029700225	KIT EHV 1-350 DIA22 VALVE C	1 L	22 mm	C*
19029800225	KIT EHV 2.5-350 DIA22 VALVE C	2,5 L	22 mm	C*
19036600225	KIT EHV 4-350 DIA22 VALVE B	4 L	22 mm	B
19029900225	KIT EHV 4-350 DIA22 VALVE C	4 L	22 mm	C*
19030100225	KIT EHV 6-350 DIA 22 VALVE C	6 L	22 mm	C*
19030200225	KIT EHV 10-350 DIA22 VALVE C	10 L (long)	22 mm	C*
19028900225	KIT EHV 10-330 DIA22 VALVE A	10 L	22 mm	A
19029000225	KIT EHV 20-330 DIA22 VALVE A	20 L	22 mm	A
19036000225	KIT EHV 20-330 DIA22 VALVE B	20 L	22 mm	B
19029100225	KIT EHV 32-330 D22 VALVE A	32 L	22 mm	A
19036100225	KIT EHV 32-330 DIA22 VALVE B	32 L	22 mm	B
19054100225	KIT EHV 50-330 DIA22 VALVE A	50 L	22 mm	A
19040800225	KIT EHV 20-250/330 D50 VALVE A	20 L	50 mm	A
19041000225	KIT EHV 32-250/330 D50 VALVE A	32 L	50 mm	A
19029200225	KIT EHV 50-250-330 DIA50 Valve A	50 L	50 mm	A
01100A-00	BLADDER KIT 1.15L 1/4"	1 L	16 mm	F*
0300A-00	BLADDER KIT 2.5L 1/4"	2.5 L	16 mm	F*
0400A-00	BLADDER KIT 4.0 1/4"	4 L	22 mm	F
1000A-00	BLADDER KIT 10.0L 1/4"	10 L	22 mm	F
2000A-00	BLADDER KIT 20.0L 1/4"	20 L	22 mm	F
3700A-00	BLADDER KIT 37.0L 1/4"	37 L	22 mm	F
5400A-00	BLADDER KIT 54.0L 1/4"	54 L	50 mm	F

* Integrated gas valve



Accumulator Set

Parker Olaer have developed an Accumulator Set which is easy to install and easy to order.

- Based on standard accumulator products, according to PED2014/68/EU, EN 14359 Fluid Group 2
- Temperature range -20°C to +80°C
- Safety Block: Includes pressure relief valve sealed, CE marked by BV
- More technical information for each product within the set is available on the Parker website and in the Accumulator Catalogue

Accumulator Set Part Number	Nominal Volume (V0)	Maximum Pressure (PS)	accumulator	clamps	Clamps Qty	Bracket	Safety block	Process connection
04323001125	2.5	350	10854701125	20251003648	1	20151903620	35128811Y02	3/4" BSP
04323101125	4	350	10845401125	20251303648	1	20118703620	35128811Y02	3/4" BSP
04323201125	6	350	10857401125	20251303648	1	20118703620	35128811Y02	3/4" BSP
04323301125	10	350	10859701125	20251303648	2	20118703620	35128811Y02	3/4" BSP
04323401125	10	330	10837001125	20251503648	1	20109003620	35128813J02	3/4" BSP
04323501125	10	330	10837001125	20251503648	1	20109003620	35129013J02	1"-1/4 SAE 6000
04323601125	20	330	10837101125	20251503648	2	20109003620	35129013J02	1"-1/4 SAE 6000
04323701125	32	330	10837301125	20251503648	2	20109003620	35129013J02	1"-1/4 SAE 6000
04323801125	50	330	11076701125	20251503648	2	20109003620	35129013J02	1"-1/4 SAE 6000

The accumulator set will be delivered in a single shipment

Accumulator pre charge at 150 Bar Nitrogen (P0)

Refer to catalogue for clamps quantity advice (additional clamps may be ordered separately)

Includes:

- 1 x Bladder Accumulator (Pre-charged 150 bar)
- Clamp(s)
- Bracket
- Safety Block



NEW - Bladder Accumulator Set

One part number - One delivery



Global Bladder Accumulator

The Parker Global Accumulator offers multi-international certification (SELO, ASME & CE) as well as improved technology and design.

- Certification CE 350 bar / ASME 3800 psi + GB 280 Mpa only for 32L and 50L (SELO)
- Carbon steel components / Mix 25 bladder
- Standard RAL5005 epoxy painting 30-50µm
- G2" "DA" fluidport (maximum flow rate = 1200 L/min) ; Gas valve B
- Standard RAL5005 epoxy painting 30-50µm
- No precharge
- English/German/Chinese name plate with double units (SI / USA)
- Name plate ready for PTS label (PTS label coming soon)
- Special packaging (box quantity - refer to table below)

- More technical information is available on the Parker website and in the Accumulator Catalogue.

Part Number	Description	Gas valve design	Effective Volume (Litres)	Pressure (PS)	DA fluid port connection	Box quantity
09504401125	EHV 10-350/94-A25HB-238	B	9.2	CE : 350 Bar ASME : 3800 psi (262 Bar) This volume is out of the SELO scope	DA G2"	9
09504601125	EHV 20-350/94-A25HB-238	B	17.8	CE : 350 Bar ASME : 3800 psi (262 Bar) This volume is out of the SELO scope	DA G2"	9
09504801125	EHV 32-350/AS-A25HB-238	B	32	CE : 350 Bar ASME : 3800 psi (262 Bar) SELO (according to GB/T-20663-2006) : 280 bar	DA G2"	6
09505001125	EHV 50-350/AS-A25HB-238	B	47.5	CE : 350 Bar ASME : 3800 psi (262 Bar) SELO (according to GB/T-20663-2006) : 280 bar	DA G2"	6

Valve B

MIX 25

**Epoxy primer
RAL5005 Thickness :
30-50µm**

**World class
Packaging and
logistics**

**Name plate English / Chinese /
German, Customer p/n and order
number on name plate**

**CE PS : 350 bar
ASME PS : 3800psi (262 bar)
SELO PS : 280 bar**

**Carbon steel , "DA" Improved flow
rate, BSPP 2"**

**PTS System Documentation
Portal**

**2 week
dispatch**
Max qty-
1 box



Crimped Piston Accumulator ACP Series 275 bar

Piston Accumulator designed for Mobile applications up to 30 litres, 100mm bore and 275 bar. The ACP piston accumulator offers long, reliable service life and due to its compact & cost effective design it is ideally suited for the mobile market.

- Standard version (Carbon Steel shell/seal NBR) compatible with mineral oils.
- According to PED 2014/68/EU, EN 14359, Fluid Group 2.
- Part numbers below are nitrogen rechargeable (including gas valve)
- A wider range of products and more technical information is available on the Parker website and in the Accumulator Catalogue.

Part number	Effective gas Volume (Litres)	Max. Working Pressure (PS)bar	Max Flow Rate l/mn**	Weight (Kg)	Dimensions (mm)					
					A	C	øD	ø Bore (Nominal)	G (BSPP) Female	G (BSPP) Male
ACP05EA100E2K*	0.95	275	380	4.1	583	25.4	60.5	50	G3/4	G1
ACP10EA200E2K	2.00	275	1504	14.8	394	25.4	120.9	100	G1	G1
ACP10EA400E2K	4.00	275	1504	21	637	25.4	120.9	100	G1	G1

* According PED 2014/68/EU Article 4.3

**Note : based on 120 in/sec maximum piston speed, port&fitting size will become limiting factors for most applications

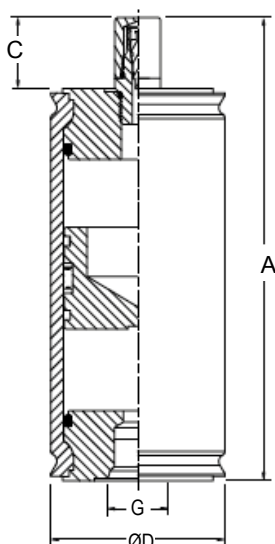

Diaphragm Accumulator DA Series

E-configurable product
 DA Accumulator Series

NBR rubber mix (previous known as ELM range)

Diaphragm accumulators are inexpensive, compact and lightweight and are ideally suited where weight and space is an important consideration. Ideally suited to Mobile -Agricultural and Construction markets (140 to 350 bar/ 0.075 to 3.5L).

Part number	Type	Clamps Model Part number	Lock nut Model Part number	Cross Reference OLAER	Cross Reference ADE
DA-007-25000AF1125PXXX*	DA-0.075L-250BAR-10849201125	-	-	ELM 0.075-250/00/AF* 10849201125	ADE007-25R1A2
DA-016-25000AF1125PXXX*	DA-0.16L-250BAR-10849301125	-	-	ELM 0.16-250/00/AF* 10849301125	ADE016-25R1A2
DA-032-21000AF1125PXXX*	DA-0.32L-210BAR-10986601125	E95 (1) 20250803648	-	ELM 0.32-210/00/AF* 10986601125	ADE032-21R1A2
DA-050-21000AF1125PXXX*	DA-0.50L-210BAR-10849501125	E106 (1) 20250903648	-	ELM 0.5-210/00/AF* 10849501125	ADE050-21R1A2
DA-075-21000AF1125PXXX*	DA-0.75L-210BAR-10849701125	E114 (1) 20251003648	-	ELM 0.75-210/00/AF* 10849701125	ADE075-21R1A2
DA-075-21000CF1125PXXX*	DA-0.75L-210BAR-10849801125	E114 (1) 20251003648	M33x1.5 10945700100	ELM 0.75-210/00/CF* 10849801125	
DA-075-35000AF1125PXXX*	DA-0.75L-350BAR-10931801125	E136 (1) 20251103648	-	ELM 0.75-350/00/AF* 10931801125	
DA-100-21000AF1125PXXX*	DA-1.00L-210BAR-10984701125	E136 (1) 20251103648	-	ELM 1-210/00/AF* 10984701125	ADE100-21R1A2
DA-140-21090AF1125PXXX	DA-1.40L-210BAR-10996501125	E155 (1) 20251203648	-	ELM 1.4-210/90/AF 10996501125	
DA-140-21090CF1125PXXX	DA-1.40L-210BAR-10996601125	E155 (1) 20251203648	M33x1.5 10945700100	ELM 1.4-210/90/CF 10996601125	
DA-140-25090AF1125PXXX	DA-1.40L-250BAR-11013201125	E155 (1) 20251203648	-	ELM 1.4-250/90/AF 11013201125	ADE140-25R1C2
DA-140-25090CF1125PXXX	DA-1.40L-250BAR-11013301125	E155 (1) 20251203648	M33x1.5 10945700100	ELM 1.4-250/90/CF 11013301125	
DA-140-35090CF1125PXXX	DA-1.40L-350BAR-10932201125	E160 (1) 20259003648	M33x1.5 10945700100	ELM 1.4-350/90/CF 10932201125	
DA-200-10090AF1125PXXX	DA-2.00L-100BAR-10850401125	E155 (1) 20251203648	-	ELM 2-100/90/AF 10850401125	
DA-200-25090BF1125PXXX	DA-2.00L-250BAR-11013401125	E155 (1) 20251203648	-	ELM 2-250/90/AF 11013401125	
DA-280-25090BF1125PXXX	DA-2.80L-250BAR-10887901125	E168 (1) 20251303648	-	ELM 2.8-250/90/AF 10887901125	ADE280-25R1C2
DA-280-35090BF1125PXXX	DA-2.80L-350BAR-10975801125	E180 (1) 20243203625	-	ELM 2.8-350/90/AF 10975801125	
DA-280-35090DF1125PXXX	DA-2.80L-350BAR-10975901125	E180 (1) 20243203625	M45X1.5	ELM 2.8-350/90/CF 10975901125	
DA-350-25090BF1125PXXX	DA-3.50L-250BAR-10850501125	E168 (1) 20251303648	-	ELM 3.5-250/90/AF 10850501125	ADE350-25R1C2

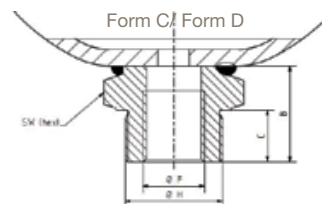
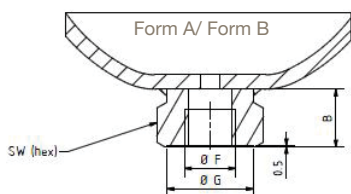

- Standard version (Carbon Steel shell/ NBR Mix 25) for mineral oils and (Carbon Steel shell/ NBR Mix 02)for low temperature
- A wider range of products and more technical information is available on the Parker website, Accumulator Catalogue and **DA Accumulator Econfigurator**.



E-configurable product
DA Accumulator Series

Type	Effective Gas vol. Litres	Max. Working pressure (PS) bar	Temp. Min/ Max (°C)	Max. Pre-charge bar	Weight kg	Dimensions in mm						Oilport	
						A max Height	B	C	SW	D	G	F	H
DA-0.075L-250BAR-10849201125	0.075	250	-10/+80	130	0.7	112	20		32	64	29	G½	-
DA-0.16L-250BAR-10849301125	0.16	250	-10/+80	130	1	120	20		32	75	29	G½	-
DA-0.32L-210BAR-10986601125	0.32	210	-10/+80	130	1.4	135	20		32	92	29	G½	-
DA-0.50L-210BAR-10849501125	0.5	210	-20/+80	130	2	153	22		41	107	34	G½	-
DA-0.75L-210BAR-10849701125	0.75	210	-20/+80	130	2.6	167	22		41	122	34	G½	-
DA-0.75L-210BAR-10849801125	0.75	210	-20/+80	130	2.6	178	33	18	41	122	-	G½	M33x1.5
DA-0.75L-350BAR-10931801125	0.75	350	-20/+80	130	4	174	22		41	128	34	G½	-
DA-1.00L-210BAR-10984701125	1	210	-20/+80	130	3.5	182	22		41	136	34	G½	-
DA-1.40L-210BAR-10996501125	1.4	210	-20/+80	130	4.2	192	22		41	148	34	G½	-
DA-1.40L-210BAR-10996601125	1.4	210	-20/+80	130	4.2	203	33	18	41	148	-	G½	M33x1.5
DA-1.40L-250BAR-11013201125	1.4	250	-20/+80	130	5.4	196	22		41	152	34	G½	
DA-1.40L-250BAR-11013301125	1.4	250	-20/+80	130	6	207	33	18	41	152	-	G½	M33x1.5
DA-1.40L-350BAR-10932201125	1.4	350	-20/+80	130	7	221	44	18	44	156	-	G½	M33x1.5
DA-2.00L-100BAR-10850401125	2	100	-10/+80	100	3.5	241	22		41	145	34	G½	
DA-2.00L-250BAR-11013401125	2	250	-10/+80	130	9.5	252	22		41	156	33	G3/4	
DA-2.80L-250BAR-10887901125	2.8	250	-10/+80	130	8.5	269	20		41	168	33	G3/4	
DA-2.80L-350BAR-10975801125	2.8	350	-10/+80	130	14.3	265	23		55	180	34	G3/4	
DA-2.80L-350BAR-10975901125	2.8	350	-10/+80	130	14.5	286	21	20	55	180	-	G3/4	M45x1.5
DA-3.50L-250BAR-10850501125	3.5	250	-10/+80	130	10.2	314	20		41	168	33	G3/4	

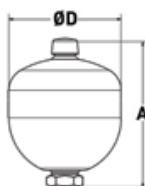

Clamps

Parker Olaer Clamps are designed to allow quick and easy installation of hydraulic accumulators.

- Available in carbon and stainless steel.
- Steel with zinc plated protection, Rubber EPDM (48) or NBR (25)
- A wider range of products and more technical information is available on the Parker website and in the Accumulator Catalogue.

Part Number	Description	inlet diameter	Design
20149203625	A56	54-56	E
20250803648	E95	97-97	E
20250903648	E106	99-109	E
20251003648	E114	112-124	E
20251103648	E136	128-124	E
20251203648	E155	146-157	E
20259003648	E160	155-165	E
20251303648	E168	166-176	E
20251503648	D226	215-226	D

Design E



Design D



Brackets

Parker Olaer Brackets are designed to allow quick and easy installation of accumulators.

- Available in carbon and stainless steel
- Carbon steel zinc plated and NBR cushion ring
- A wider range of products and more technical information is available on the Parker website and in the Accumulator Catalogue.

Part Number	Description	Bladder Accumulator model
20151903620	CE89	1 to 5 liters
20118703620	CE108	4, 6 , 10 liters
20109003620	CE159A	10 to 50 liters

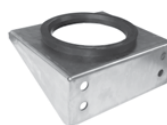

Charging Sets

The Parker Charging kit is an indispensable instrument for checking, adjusting or filling nitrogen into most of the hydraulic accumulators available on the market.

- For membrane accumulators no adaptor is required.
- All country adaptors and more technical data available
- A wider range of products and more technical information is available on the Parker website and in the Accumulator Catalogue.

Part Number	Description	Country	Pressure
20214122823	VGU/F.25/250.8.TS2.3	France	0-250
20214122833	VGU/F.25/250.8.TS3.3	Germany	0-250
20214122893	VGU/F.25/250.8.TS9.3	Netherlands	0-250

Charging Set Includes:

- VGU universal tester and pressuriser
- Set of accumulator adaptors (5/8", 7/8", 7/8" long, G1/4", 8V1)
- 1 pressure gauge 0-25 Bar
- 1 pressure gauge 0-250 Bar (other pressure gauges available on request)
- Special nitrogen hose (length 2,5 m)
- Nitrogen connection according to country standard.



Safety Blocks

Parker Olaer has developed a complete range of Accumulator Safety Blocks for all standard and special applications. An accumulator safety block provides a safe solution for accumulator maintenance and operation.

- Safety blocks delivered assembled
- Minimum Temp: -15°C (except size 10: -10°C) Maximum Temp: +70°C (except size 16: +80°C)
- Pressure relief valve sealed, delivered with EC declaration of manufacturing conformity
- Also available with electrical drain valve (24 V DC or 110 V AC or 220 V AC)

- A wider range of products and more technical information is available on the Parker website and in the Accumulator Catalogue.

Safety Block with EC Safety Valve - certified by BV

Part Number	Description	Size	Pressure (Bar)	Accumulator Connection	Process Connection	Image
35172112Y02	DI10MS/2/350CV	10	350	3/4"	G 1/2"	A
35172111Y02	DI10MS/1/350CV	10	350	1"-1/4	G 1/2"	A
3512881Y02	DI16MS/1/350CV	16	350	1"-1/4	G 3/4 "	B
35128813J02	DI16MS/3/330CV	16	330	2"	G 3/4"	B
35129011Y02	DI24MS/1/350CV	24	350	1"-1/4	1-1/4" SAE 6000	D
35129013J02	DI24MS/3/330CV	24	330	2"	1-1/4" SAE 6000	D

Safety Block with EC Safety Valve - certified by TUV

Part Number	Description	Size	Pressure (Bar)	Accumulator Connection	Process Connection	Image
FTD.021-1-10333000	DI 10 MS 2-330-BH-000	10	330	Requires Adaptor	G 1/2"	A
FTD.021-1-10213000	DI 10 MS 2-211-BH-000	10	210	Requires Adaptor	G 1/2"	A
FTD.021-2-10303000	DI 20 MS 2-300-BH-000	20	300	Requires Adaptor	G 1"	C
FTD.021-2-10333000	DI 20 MS 2-330-BH-000	20	330	Requires Adaptor	G 1"	C

FTD.21-D30102	Adaptor G 3/4"	Adaptors for FTD Safety Blocks
FTD.21-D30103	Adaptor G 1-1/4"	
FTD.21-D30104	Adaptor G 2"	

Image A

Image B

Image C

Image D



Pressure Relief Valve Block

Parker Olaer has developed a complete range of pressure relief valve blocks for all standard applications. This provides the minimal pressure protection required to protect an accumulator against excessive pressure.

- Pressure relief block delivered assembled; Pressure relief valve sealed delivered with EC certified by BV declaration of manufacturing conformity.
- A wider range of products and more technical information is available on the Parker website and in the Accumulator Catalogue.

Part Number	Description	Size	Pressure (Bar)	Accumulator Connection	Image																	
35170913502	SL 16/1/350CV	16	350 B	1"-1/4	A																	
35170913302	SL 16/1/330CV	16	330 B	1"-1/4	A																	
35170733302	SL 24/3/330CV	24	2"	A	35170732502	SL 24/3/250CV	24	250 B	2"	A	35170602502	SD 24/0/250CV	24	250 B	1/2"	B	35170603302	SD 24/0/330CV	24	330 B	1/2"	B
35170732502	SL 24/3/250CV	24	250 B	2"	A																	
35170602502	SD 24/0/250CV	24	250 B	1/2"	B																	
35170603302	SD 24/0/330CV	24	330 B	1/2"	B																	

Image A



Image B



Adaptors

Parker Olaer has developed a complete range of adaptors for all standard fluid ports. The adaptors ensure that you have the right connection according to your network piping.

- Carbon steel plated ; also available in stainless steel
- A wider range of products and more technical information is available on the Parker website and in the Accumulator Catalogue.

Part Number	Dimension	Design	Sealing system
04556400223	G3/4 --> G3/8	A	Seal in angle
04502000223	G3/4 --> BLIND	A	Seal in angle
04555100223	G 1-1/4 --> G1/2	A	Seal in angle
04555200223	G1-1/4 --> G3/4	A	Seal in angle
04502200223	G1-1/4 --> Blind	A	Seal in angle
04556900223	G2 --> G3/4	A	Seal in angle
04557000223	G2 --> G1	A	Seal in angle
04557100223	G2 --> G1-1/4	A	Seal in angle
04502400223	G2 --> Blind	A	Seal in angle
04555800223	G 1-1/4 --> G1/2	B	Seal in fluid port
04555900223	G1-1/4 --> G3/4	B	Seal in fluid port
04557800223	G2 --> G3/4	B	Seal in fluid port
04557900223	G2 --> G1	B	Seal in fluid port
04558000223	G2 --> G1-1/4	B	Seal in fluid port
50038-V10	G 1-1/4 --> G1/2	C	Bonded seal
50040-V10	G1-1/4 --> G3/4	C	Bonded seal
50042-V10	G2 --> G1/2	C	Bonded seal
50043-V10	G2 --> G 3/4	C	Bonded seal
50044-V10	G2 --> G1	C	Bonded seal

Design A - Seal in angle

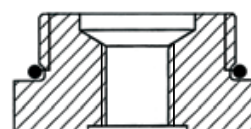

Design B - Seal in fluid port

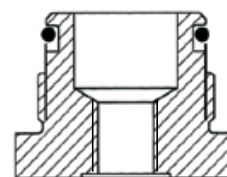

Design C - Bonded seal fluid port

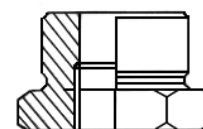

Gas Bottles

Parker Gas Bottles store nitrogen under pressure and provide additional gas volume typically for accumulator systems. The BAWN Gas Bottles without neck are interchangeable and can easily replace an existing unit whilst also offering a cost effective solution for hydraulic systems.

- According to PED 2014/68/EU, EN 14359 and ASME VIII div1 App22. Fluid Group 2.

Part Number	Description	Volume (L)	Pressure (bar)	Dimensions (mm)		Fluid port connection
				A	D	
83101030	BAWN 50.360-207 PED+U NO/NECK 1"1/2-3/4"GAS CIL.	50	360	1615	229	G3/4 & G1-1/2
83101040	BAWN 75.360-207 PED+U NO/NECK 1"1/2-3/4"GAS CIL.	75	360	2280	229	G3/4 & G1-1/2

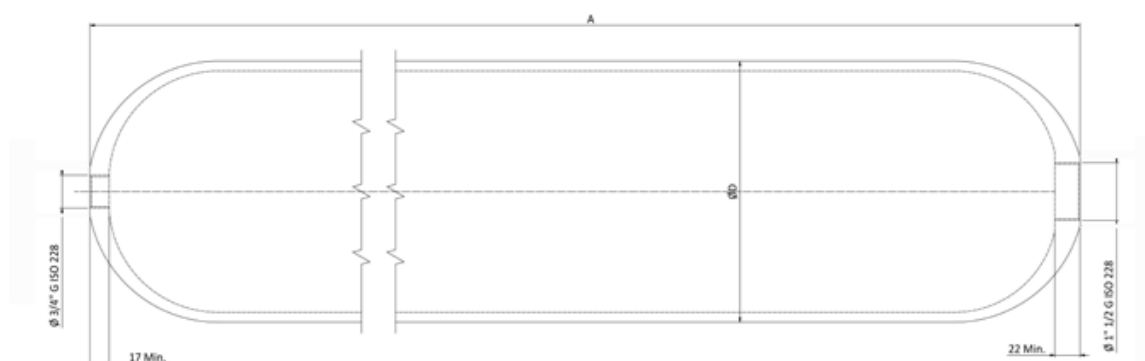

How to size an accumulator

Accumulator Sizing Software

www.parker.com/acde

Parker Olaer has developed very sophisticated simulation software to optimise accumulator sizing recommendations.

Calculations are based on the real gas equation and real gases. The software allows for temperature and flow characteristics and has an intuitive Windows format that is easy to use!

The behaviour of accumulators used in applications such as pulsation dampening, surge arrestor, thermal expansion and energy storage can be simulated.

The latest version of the sizing software can be downloaded from our website.



Sizing Questionnaires

Customers can complete a sizing questionnaire and send this to the local Parker Sales Office so that the most efficient accumulator can be sized for your application.

You can download the sizing questionnaires from our website www.parker.com/acde or click on the links below if you are viewing a digital version of this document.

There are 4 questionnaires to select from:-

1. Energy Storage - [LINK](#)
2. Thermal Expansion in a closed circuit - [LINK](#)
3. Surge Arrestor / Waterhammer - [LINK](#)
4. Pulsation Damper - [LINK](#)

DATA SHEET Application : ENERGY STORAGE			
Date:			
Company Name:		Contact Name:	
Market Segment: <small>expt. O&G, Distribution, Marine, Industrial, Offshore, Service</small>		E-mail:	
Address:		Telephone:	
Website:			
SIZING DATA			
Describe application:			
Please attached system scheme			
Fluid Type:			
Volume of Fluid to be restored:			Ltr.
Dual Time (Charge-Stabilisation-Discharge):			Sec
Maximum Working Pressure (P2):			Bar
Minimum Working Pressure (P1):			Bar
Fluid Temperature during Operation:		Min. °C	Max. °C
Certification:			
TECHNICAL SPECIFICATION OR SPECIAL REQUIREMENTS HAVE TO BE FILLED IN			
<ul style="list-style-type: none"> - Material options : - Special Port Connections and adaptors : - Special Coatings : - End user country : 			
<small>If there is no special requirement, we will offer standard connection and material according to the fluid and PED 97/23/EC (**)</small>			



Coolers

Air Oil Coolers & Water Oil Coolers and Pumps



Air Oil Cooler with AC Motor - LAC Series

Suitable for most Industrial applications, the LAC air oil cooler series offers an efficient and robust design and is available in a range of cooling capacities from 1kW to 300 kW.

- A wider range of products and more technical information is available on the Parker website and in the LAC Cooler Catalogue.

Part Number	TYPE	Dimensions (mm)												
		A	B	C	D	E	F	G	H	I	J	K	L	M \varnothing
LAC2-0042DB0000000S0JB0	LAC2-004-2-D-00-000-0-0	267	134	82	256	69	G1	148	90	131	165	222	28	9x14
LAC2-0042DB5000000S0JB0	LAC2-004-2-D-50-000-0-0	267	134	82	256	69	G1	148	90	131	165	222	28	9x14
LAC2-0074DC0000000S0JB0	LAC2-007-4-D-00-000-0-0	365	203	64	395	42	G1	510	160	213	225	429	50	9
LAC2-0074DC5000000S0JB0	LAC2-007-4-D-50-000-0-0	365	203	64	395	42	G1	510	160	213	225	429	50	9
LAC2-0074DC00S50200S0JB0	LAC2-007-4-D-00-S50-0-0	365	203	64	395	42	G1	510	160	213	225	429	50	9
LAC2-0074DC50S50200S0JB0	LAC2-007-4-D-50-S50-0-0	365	203	64	395	42	G1	510	160	213	225	429	50	9
LAC2-0114DC0000000S0JB0	LAC2-011-4-D-00-000-0-0	440	203	62	470	41	G1	510	230	250	249	453	50	9
LAC2-0114DC5000000S0JB0	LAC2-011-4-D-50-000-0-0	440	203	62	470	41	G1	510	230	250	249	453	50	9
LAC2-0114DC00S50200S0JB0	LAC2-011-4-D-00-S50-0-0	440	203	62	470	41	G1	510	230	250	249	453	50	9
LAC2-0114DC50S50200S0JB0	LAC2-011-4-D-50-S50-0-0	440	203	62	470	41	G1	510	230	250	249	453	50	9
LAC2-0164DC0000000S0JB0	LAC2-016-4-D-00-000-0-0	496	203	66	526	46	G1	510	230	278	272	479	50	9
LAC2-0164DC5000000S0JB0	LAC2-016-4-D-50-000-0-0	496	203	66	526	46	G1	510	230	278	272	479	50	9
LAC2-0164DC00S50200S0JB0	LAC2-016-4-D-00-S50-0-0	496	203	66	526	46	G1	510	230	278	272	479	50	9
LAC2-0164DC50S50200S0JB0	LAC2-016-4-D-50-S50-0-0	496	203	66	526	46	G1	510	230	278	272	479	50	9
LAC2-0234AC0000000S0JB0	LAC2-023-4-D-00-000-0-0	580	356	63	610	44	G1	510	305	320	287	511	50	9
LAC2-0234AC5000000S0JB0	LAC2-023-4-D-50-000-0-0	580	356	63	610	44	G1	510	305	320	287	511	50	9
LAC2-0234AC00S50200S0JB0	LAC2-023-4-D-00-S50-0-0	580	356	63	610	44	G1	510	305	320	287	511	50	9
LAC2-0234AC50S50200S0JB0	LAC2-023-4-D-50-S50-0-0	580	356	63	610	44	G1	510	305	320	287	511	50	9
LAC-0334AC0000000S0JB0	LAC-033-4-A-00-000-0-0	692	356	53	722	42	G1¼	510	406	376	318	618	50	9
LAC-0334AC5000000S0JB0	LAC-033-4-A-50-000-0-0	692	356	53	722	42	G1¼	510	406	376	318	618	50	9
LAC-0334AC00S50200S0JB0	LAC-033-4-A-00-S50-0-0	692	356	53	722	42	G1¼	510	406	376	318	618	50	9
LAC-0334AC50S50200S0JB0	LAC-033-4-A-50-S50-0-0	692	356	53	722	42	G1¼	510	406	376	318	618	50	9
LAC-0444AC0000000S0JB0	LAC-044-4-A-00-000-0-0	692	356	53	866	59	G1¼	510	584	448	343	643	50	9
LAC-0444AC5000000S0JB0	LAC-044-4-A-50-000-0-0	692	356	53	866	59	G1¼	510	584	448	343	643	50	9
LAC-0444AC00S50200S0JB0	LAC-044-4-A-00-S50-0-0	692	356	53	866	59	G1¼	510	584	448	343	643	50	9
LAC-0444AC50S50200S0JB0	LAC-044-4-A-50-S50-0-0	692	356	53	866	59	G1¼	510	584	448	343	643	50	9
LAC-0584AC0000000S0JB0	LAC-058-4-A-00-000-0-0	868	508	49	898	43	G2	510	584	464	388	688	30	9
LAC-0584AC5000000S0JB0	LAC-058-4-A-50-000-0-0	868	508	49	898	43	G2	510	584	464	388	688	30	9
LAC-0584AC00S50200S0JB0	LAC-058-4-A-00-S50-0-0	868	508	49	898	43	G2	510	584	464	388	688	30	9
LAC-0584AC50S50200S0JB0	LAC-058-4-A-50-S50-0-0	868	508	49	898	43	G2	510	584	464	388	688	30	9



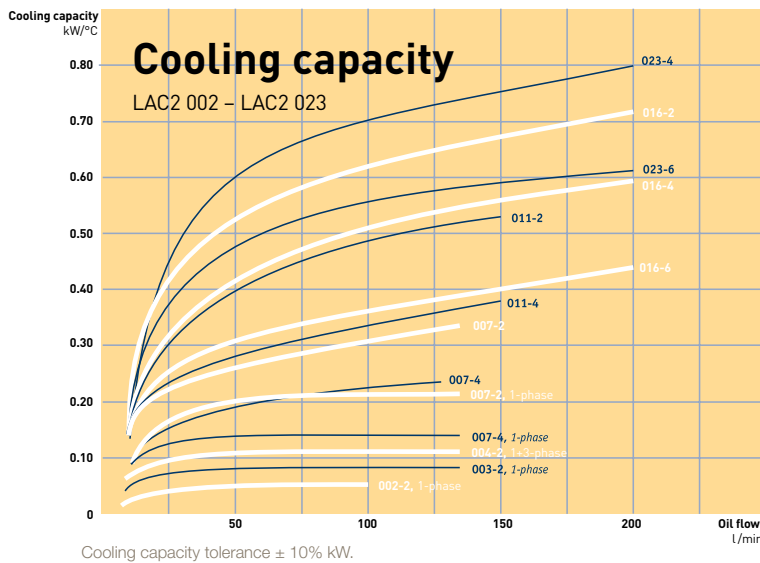
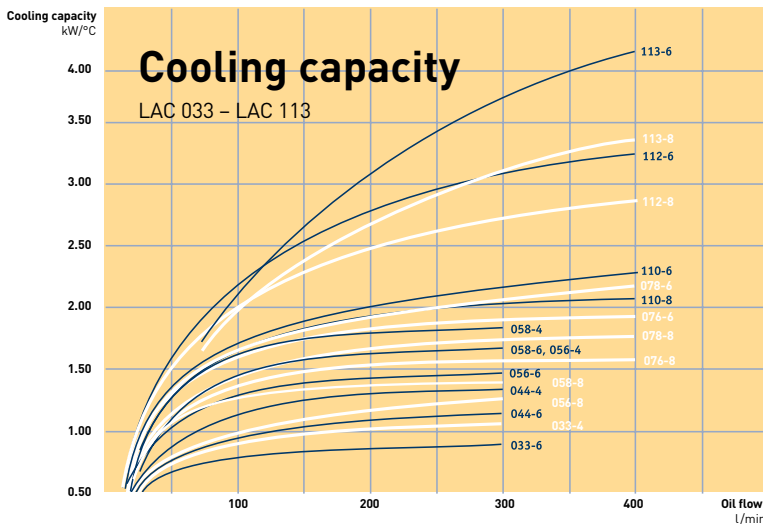
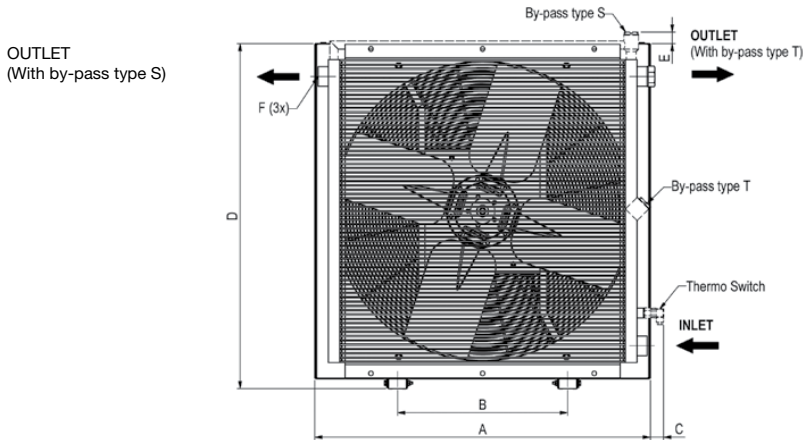

Air Oil Cooler with DC Motor - LDC Series

The LDC air oil cooler series with 12 or 24V DC motor is optimized for use in the mobile industry and is available in a range of cooling capacities from 1kW to 30 kW.

- A wider range of products and more technical information is available on the Parker website and in the LDC Cooler Catalogue.

Part Number	TYPE	Dimensions (mm)																Weight kg (approx)	Acoustic Pressure LpA dB(A)1m*
		A	B	C	D	E	F	G	H	I	J	K	L	Mø	N	O	P		
5837007007	LDC-007-B-0-00-000-0-0	330	203	82	345	54	G1	267	160	175	115	178	59	9	-	23	44	9	71
5837007002	LDC-007-B-0-50-000-0-0	330	203	82	345	54	G1	267	160	175	115	178	59	9	-	23	44	9	71
5837007034	LDC-007-B-0-00-S50-0-0	330	203	82	345	54	G1	267	160	175	115	178	59	9	-	23	44	9	71
5837007060	LDC-007-B-0-50-S50-0-0	330	203	82	345	54	G1	267	160	175	115	178	59	9	-	23	44	9	71
5827011025	LDC-011-B-0-00-000-0-0	400	360	82	396	65	G1	101	230	200	125	218	-	9x29	-	23	44	12	74
5827011002	LDC-011-B-0-50-000-0-0	400	360	82	396	65	G1	101	230	200	125	218	-	9x29	-	23	44	12	74
5827011020	LDC-011-B-0-00-S50-0-0	400	360	82	396	65	G1	101	230	200	125	218	-	9x29	-	23	44	12	74
5827011017	LDC-011-B-0-50-S50-0-0	400	360	82	396	65	G1	101	230	200	125	218	-	9x29	-	23	44	12	74
5827016012	LDC-016-B-0-00-000-0-0	464	416	82	466	63	G1	101	300	235	125	218	-	9x29	-	23	44	15	74
5827016002	LDC-016-B-0-50-000-0-0	464	416	82	466	63	G1	101	300	235	125	218	-	9x29	-	23	44	15	74
5827016023	LDC-016-B-0-00-S50-0-0	464	416	82	466	63	G1	101	300	235	125	218	-	9x29	-	23	44	15	74
5827016022	LDC-016-B-0-50-S50-0-0	464	416	82	466	63	G1	101	300	235	125	218	-	9x29	-	23	44	15	74
5827023012	LDC-023-B-0-00-000-0-0	615	356	46	635	26	G1	290	305	200	125	218	50	13	455	-	8	25	77
5827023002	LDC-023-B-0-50-000-0-0	615	356	46	635	26	G1	290	305	200	125	218	50	13	455	-	8	25	77
5827023004	LDC-023-B-0-00-S50-0-0	615	356	46	635	26	G1	290	305	200	125	218	50	13	455	-	8	25	77
5827023015	LDC-023-B-0-50-S50-0-0	615	356	46	635	26	G1	290	305	200	125	218	50	13	455	-	8	25	77
5827033008	LDC-033-B-0-00-000-0-0	635	356	82	678	59	G1¼	290	406	220	165	258	50	13	478	25	49	30	77
5827033002	LDC-033-B-0-50-000-0-0	635	356	82	678	59	G1¼	290	406	220	165	258	50	13	478	25	49	30	77
5827033011	LDC-033-B-0-00-S50-0-0	635	356	82	678	59	G1¼	290	406	220	165	258	50	13	478	25	49	30	77
5827033004	LDC-033-B-0-50-S50-0-0	635	356	82	678	59	G1¼	290	406	220	165	258	50	13	478	25	49	30	77

* = Noise level tolerance ± 3 dB(A)

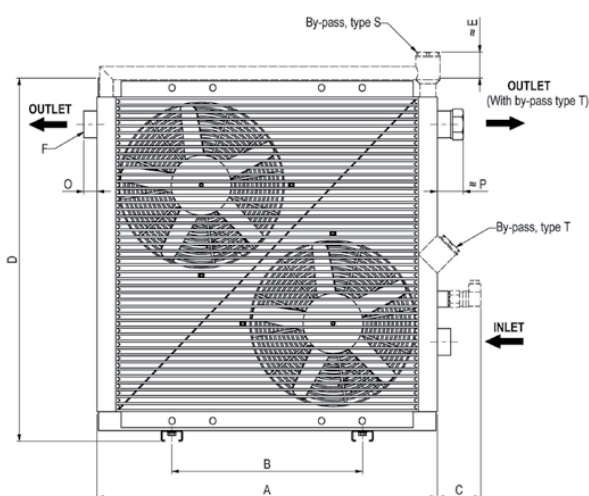
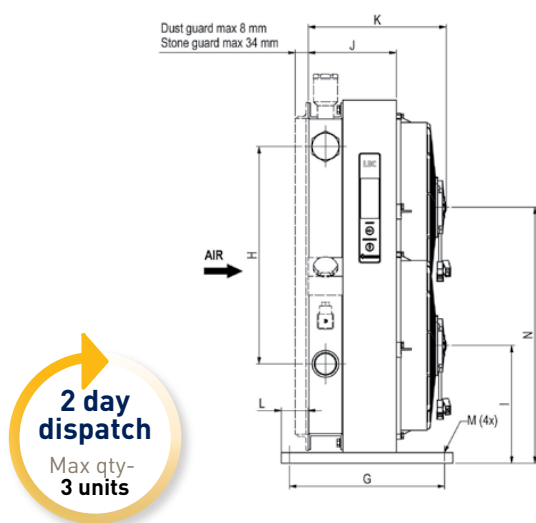

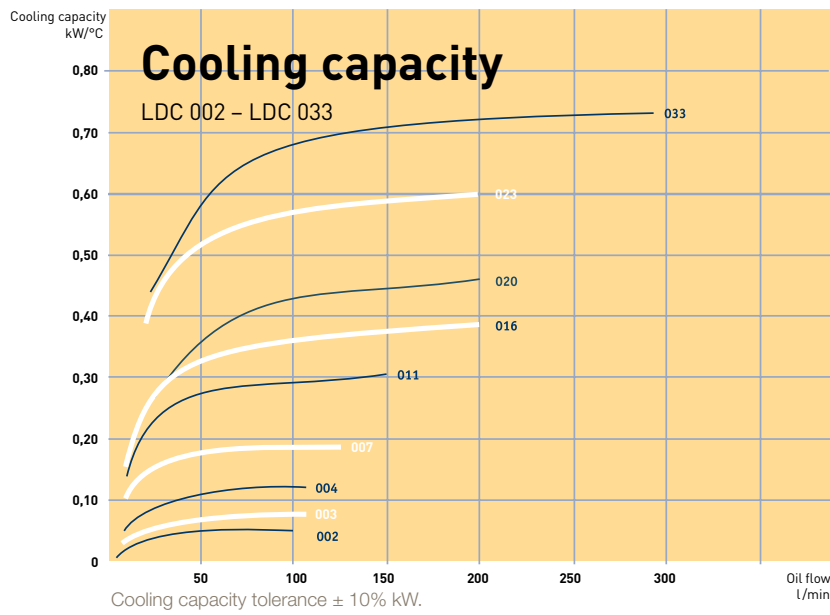

The cooling capacity curves are based on the inlet oil temperature and the ambient air temperature. An oil temperature of 60 °C and an air temperature of 20 °C produce a temperature difference of 40 °C. Multiply by kW/°C for total cooling capacity.



Air Oil Cooler with AC Motor & Pump - LOC Series

LOC cooler works as a closed cooling loop. The LOC Air Oil Cooling System with AC-motor and pump provides cooling up to 45kW. Its robust construction makes it suitable for most applications and environments. - A wider range of products and more technical information is available on the Parker website and in the LOC Cooler Catalogue.

Part Number	TYPE	Dimensions (mm)														
		A	B	C	D	E	F	G	H	I	J	K	L	M	N	O
5849007001	LOC3-007-4-D-A-0-00-000-0-00-0	365	395	602	203	510	Ø9	G1	292	83	214	62	80	50	45	105
5849007201	LOC3-007-4-D-B-0-00-000-0-00-0	365	395	615	203	510	Ø9	G1	292	83	214	74	80	50	45	105
5849011001	LOC3-011-4-D-A-0-00-000-0-00-0	440	470	626	203	510	Ø9	G1	366	83	252	62	175	50	41	103
5849011201	LOC3-011-4-D-B-0-00-000-0-00-0	440	470	639	203	510	Ø9	G1	366	83	252	74	175	50	41	103
5849016201	LOC3-016-4-D-B-0-00-000-0-00-0	365	395	680	203	510	Ø9	G1	292	83	214	100	80	50	45	105
5849016401	LOC3-016-4-D-C-0-00-000-0-00-0	496	526	712	203	510	Ø9	G1	427	83	280	87	300	50	46	107
5849016601	LOC3-016-4-D-D-0-00-000-0-00-0	496	526	725	203	510	Ø9	G1	427	83	280	100	300	50	46	107
5849023001	LOC3-023-4-D-B-0-00-000-0-00-0	580	610	729	356	610	Ø14	G1	509	98	322	74	385	65	44	104
5849023201	LOC3-023-4-D-C-0-00-000-0-00-0	580	610	770	356	610	Ø14	G1	509	98	322	87	385	65	44	104
5849023401	LOC3-023-4-D-D-0-00-000-0-00-0	580	610	783	356	610	Ø14	G1	509	98	322	100	385	65	44	104
5849033006	LOC3-033-4-A-B-0-00-000-0-00-0	692	722	785	356	610	Ø14	G1 1/4	619	103	378	74	326	70	38	99
5849033001	LOC3-033-4-A-C-0-00-000-0-00-0	692	722	798	356	610	Ø14	G1 1/4	619	103	378	87	326	70	38	99
5849033201	LOC3-033-4-A-D-0-00-000-0-00-0	692	722	810	356	610	Ø14	G1 1/4	619	103	378	100	326	70	38	99

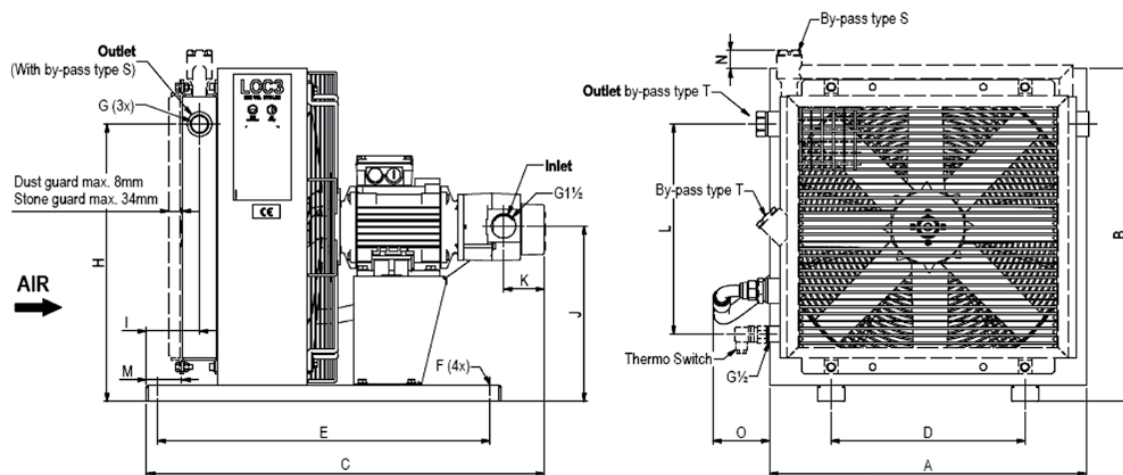

All dimensions are reference.
The design specification take presence at all time.



TYPE	Nom. oil flow l/min	Cooling capacity in kW at EDT 40 °C	Cooling capacity kW/°C	Acoustic pressure level LpA dB(A) 1m*	No. of poles/ Capacity kW	Weight kg (approx)
LOC3 007 - 4 - D - A	20	5.6	0.14	64	4-0.75	30
LOC3 007 - 4 - D - B	40	7.2	0.18	64	4-0.75	30
LOC3 011 - 4 - D - A	20	9.2	0.23	70	4-0.75	34
LOC3 011 - 4 - D - B	40	10.4	0.26	70	4-0.75	34
LOC3 016 - 4 - D - B	40	15.6	0.39	74	4-1.50	45
LOC3 016 - 4 - D - C	60	18.0	0.45	74	4-1.50	45
LOC3 016 - 4 - D - D	80	19.6	0.49	74	4-1.50	45
LOC3 023 - 4 - D - B	40	21.2	0.53	77	4-1.50	53
LOC3 023 - 4 - D - C	60	24.4	0.61	77	4-2.20	62
LOC3 023 - 4 - D - D	80	26.8	0.67	77	4-2.20	62
LOC3 033 - 4 - A - B	40	28.8	0.72	85	4-3.00	76
LOC3 033 - 4 - A - C	60	32.0	0.80	85	4-3.00	76
LOC3 033 - 4 - A - D	80	34.8	0.87	85	4-3.00	76

* = Electric motors specified are calculated for max. working pressure 6 bar at 125 cSt and 50 Hz, 4 bar at 125 cSt and 60 Hz. If you require higher pressure, please contact us for a choice of motors with a higher output.

** = Noise level tolerance ± 3 dB(A).



Brazed Plate Water Oil Cooler - PWO Series

The Parker PWO is a compact and lightweight brazed plate heat exchanger with a high cooling capacity for its size.

- Maxi pressure: 31 Bar
- Temperature range: - 196°C up to +225°C
- A wider range of products and more technical information is available on the Parker website and in the PWO Cooler Catalogue.

Part Number	description	size	Nb plate	Height A (mm)	Width B (mm)	Depth E + F + G (mm)	Empty Weight (kg)	connection	Maximum Cooling Capacity (kW) ΔT 40°	Clamp	Vibration Damper
508454	PWO B5THx10/1P-SC-M 2x3/4" INT HEX + 2x1/2" INT HEX	5	10	193	76	53.5	1	2x3/4" INT HEX + 2x1/2" INT HEX	8 (at oil flow 67 l/min)	PWOCLAMP B5	214025
508460	PWO B8TH*30/1P-SC-M 2*3/4" INT HEX + 2x1/2" INT HEX	8	30	317	76	98.3	3.21	2x3/4" INT HEX 2x1/2" INT HEX	27 (at oil flow 80 l/min)	PWOCLAMP B8	214025
50831006	PWO B10TH*40/1P-SC-S 2*1" INT HEX + 2x3/4" INT HEX	10	40	289	119	119.7	5.39	2x1" INT HEX + 2x3/4" INT HEX	53 (at oil flow 150 l/min)	PWOCLAMP B10B12	214025
50832505	PWO B25TH*50/1P-SC-S 2*1" 1/4 INT HEX + 2x1" INT HEX	25	50	526	119	142.1	11.15	2x1 1/4" INT HEX 2x1" INT HEX	79 (at oil flow 150 liter/min)	PWOCLAMP B25B28	214025

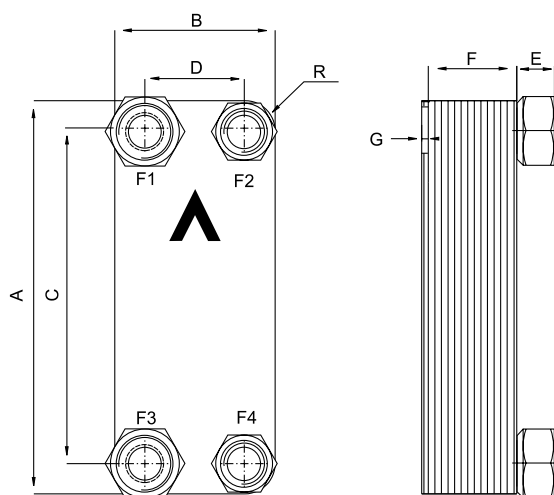

Shell and Tube Water Oil Cooler - SWO Series

The Parker SWO Water Oil Cooler is lightweight, compact and efficient shell and tube cooler for industrial and marine applications.

- Maximum pressure- water side: 10 Bar, water side : 15 Bar
- Maximum temperature: +95°C
- A wider range of products and more technical information is available on the Parker website and in the SWO Cooler Catalogue.

Industrial

Part Number	description	shell Ø (mm)	Length (mm)	Connection	Dissipated Power
5150103	SWO TP-A3	86	349	3/4"	9
5150205	SWO TP-B5	108	730	1"	29
5150304	SWO TP-C4	130	744	1-1/4"	48

Marine

Part Number	description	shell Ø	length	Connection	Dissipated Power
51503021	SWO TP-C2M	130	472	1-1/4"	26
51504031	SWO TP-D3M	162	780	1-1/2"	66
51505011	SWO TP-E1M	198	675	2"	76



Gerotor Pump - QPM3 Series

The Parker QPM3 Gerotor Pump is a low pressure pump for high efficiency.

- Maximum pressure: 10 bar
- Flow rate: from 10 l/min to 80l/min
- A wider range of products and more technical information is available on the Parker website and in the QPM3 Cooler Catalogue.

Part Number	Description	Motor Power (kW)	Flow Rate (lpm)	Weight (kg)	Noise LpA dB(A) at 1m	Approx length C (mm) - may vary with motor supplier	Height K (mm)	Width H (mm)	Fixing point for feet F (mm)
58632001	QPM3 20-4-0,75 230/400-50	0.75	20	13	65	368	195	157	125
58632050	QPM3 20-4-1,5 230/400-50	1.5	20	21	66	443	220	185	140
58634001	QPM3 40-4-0,75 230/400-50	0.75	40	13	65	381	195	157	125
58634050	QPM3 40-4-1,5 230/400-50	1.5	40	21	66	456	220	185	140
58634080	QPM3 40-4-2,2 230/400-50	2.2	40	28	67	502	240	206	160
58634090	QPM3 40-4-3,0 230/400-50	3	40	28	67	502	240	206	160
58636001	QPM3 60-4-0,75 230/400-50	0.75	60	14	65	393	195	157	125
58636020	QPM3 60-4-1,5 230/400-50	1.5	60	22	66	468	220	185	140
58636050	QPM3 60-4-2,2 230/400-50	2.2	60	28	67	514	240	206	160
58636080	QPM3 60-4-3,0 230/400-50	3	60	28	67	514	240	206	160
58638001	QPM3 80-4-1,5 230/400-50	1.5	80	22	67	481	220	185	140
58638030	QPM3 80-4-2,2 230/400-50	2.2	80	28	67	527	240	206	160
58638061	QPM3 80-4-3,0 230/400-50	3	80	28	67	527	240	206	160



How to size a cooler

More Cooling per €
with precise calculations and our engineers' support

Optimal sizing produces efficient cooling. Correct sizing requires knowledge and experience. Our calculation program, combined with our engineers' support, gives you access to this very knowledge and experience. The result is more cooling per € invested. The user-friendly calculation program can be downloaded from www.parker.com/acde.

Valuable system review into the bargain

A more wide-ranging review of the hydraulic system is often a natural element of cooling calculations. Other potential system improvements can then be discussed – e.g. filtering, offline or online cooling, etc. Contact us for further guidance and information.

Parker Hannifin's quality and performance guarantee insurance for your operations and systems

A constant striving towards more cost-efficient and environment friendly hydraulic systems requires continuous development. Areas where we are continuously seeking to improve performance include cooling capacity, noise level, pressure drop and fatigue. Meticulous quality and performance tests are conducted in our laboratory. All tests and measurements take place in accordance with standardised methods - cooling capacity in accordance with EN1048, noise level ISO 3743, pressure drop EN 1048 and fatigue ISO 10771-1.



www.parker.com/acde

Sizing Questionnaires

Customers can complete a sizing questionnaire and send this to the local Parker Sales Office so that the most efficient cooler can be sized for your application.

You can download the sizing questionnaires from our website www.parker.com/acde or click on the links below if you are viewing a digital version of this document.

There are 2 questionnaires to select from:-

1. **Air Oil Cooler Sizing - LINK**
2. **Water Oil Cooler Sizing - LINK**

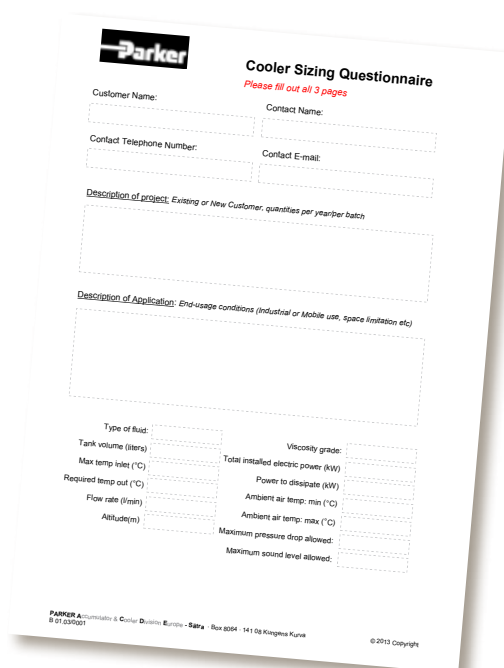

Online Support

www.parker.com/acde

You can find the latest product information on the Parker website, parker.com/acde.

You will also find all of our latest brochures and catalogues on the website.

Designed to be accessible via desktops, tablets and smart phones you can download sizing software, e-configurators, manuals and 3D models.

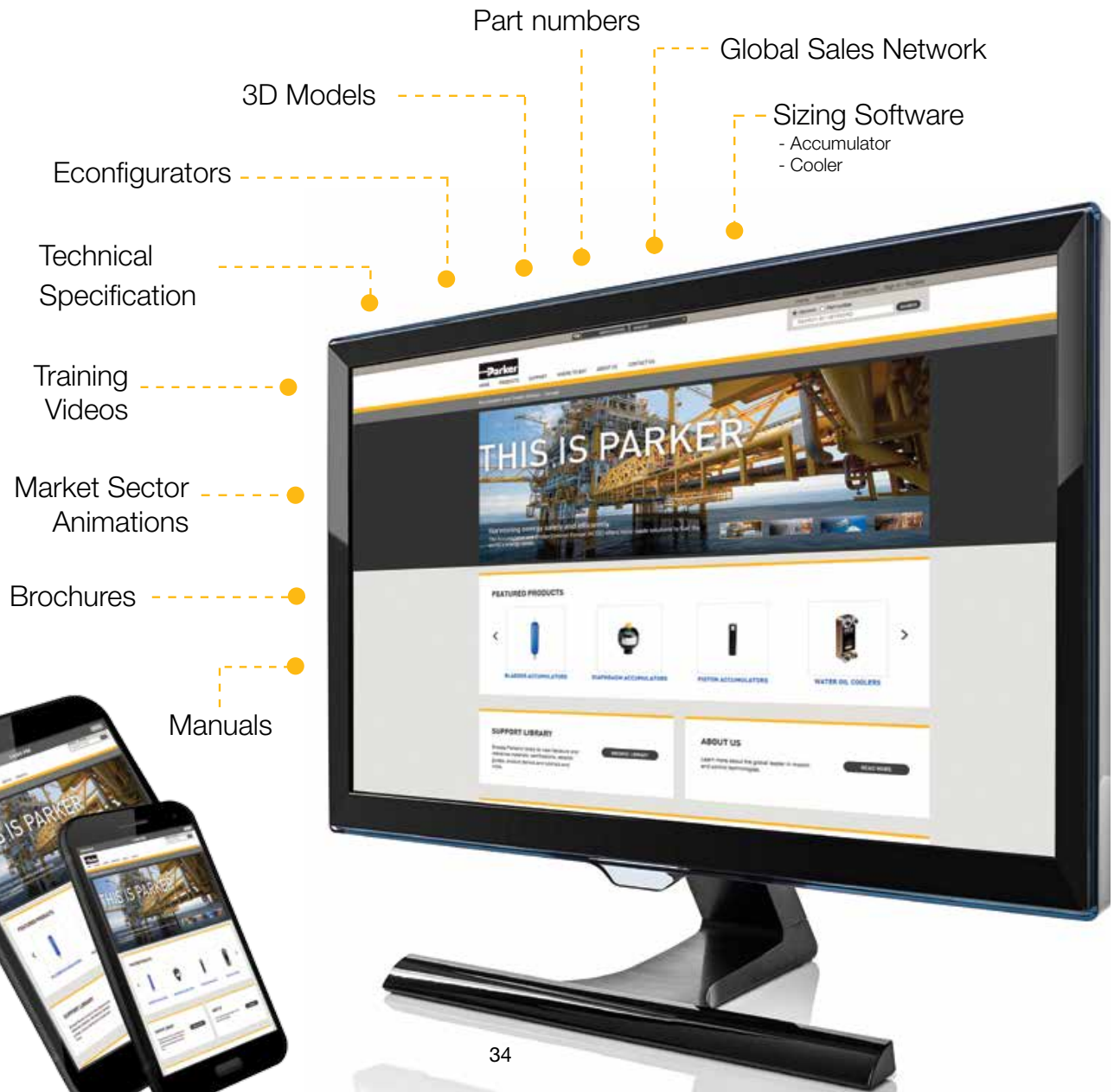

Parker Worldwide

Europe, Middle East, Africa

AE – United Arab Emirates, Dubai
Tel: +971 4 8127100
parker.me@parker.com

AT – Austria, Wiener Neustadt
Tel: +43 (0)2622 23501-0
parker.austria@parker.com

AT – Eastern Europe, Wiener Neustadt
Tel: +43 (0)2622 23501 900
parker.easteurope@parker.com

AZ – Azerbaijan, Baku
Tel: +994 50 2233 458
parker.azerbaijan@parker.com

BE/LU – Belgium, Nivelles
Tel: +32 (0)67 280 900
parker.belgium@parker.com

BG – Bulgaria, Sofia
Tel: +359 2 980 1344
parker.bulgaria@parker.com

BY – Belarus, Minsk
Tel: +48 (0)22 573 24 00
parker.poland@parker.com

CH – Switzerland, Etoy
Tel: +41 (0)21 821 87 00
parker.switzerland@parker.com

CZ – Czech Republic, Klecany
Tel: +420 284 083 111
parker.czechrepublic@parker.com

DE – Germany, Kaarst
Tel: +49 (0)2131 4016 0
parker.germany@parker.com

DK – Denmark, Ballerup
Tel: +45 43 56 04 00
parker.denmark@parker.com

ES – Spain, Madrid
Tel: +34 902 330 001
parker.spain@parker.com

FI – Finland, Vantaa
Tel: +358 (0)20 753 2500
parker.finland@parker.com

FR – France, Contamine s/Arve
Tel: +33 (0)4 50 25 80 25
parker.france@parker.com

GR – Greece, Athens
Tel: +30 210 933 6450
parker.greece@parker.com

HU – Hungary, Budaörs
Tel: +36 23 885 470
parker.hungary@parker.com

IE – Ireland, Dublin
Tel: +353 (0)1 466 6370
parker.ireland@parker.com

IL – Israel
Tel: +39 02 45 19 21
parker.israel@parker.com

IT – Italy, Corsico (MI)
Tel: +39 02 45 19 21
parker.italy@parker.com

KZ – Kazakhstan, Almaty
Tel: +7 7273 561 000
parker.easteurope@parker.com

NL – The Netherlands, Oldenzaal
Tel: +31 (0)541 585 000
parker.nl@parker.com

NO – Norway, Asker
Tel: +47 66 75 34 00
parker.norway@parker.com

PL – Poland, Warsaw
Tel: +48 (0)22 573 24 00
parker.poland@parker.com

PT – Portugal
Tel: +351 22 999 7360
parker.portugal@parker.com

RO – Romania, Bucharest
Tel: +40 21 252 1382
parker.romania@parker.com

RU – Russia, Moscow
Tel: +7 495 645-2156
parker.russia@parker.com

SE – Sweden, Spånga
Tel: +46 (0)8 59 79 50 00
parker.sweden@parker.com

SK – Slovakia, Banská Bystrica
Tel: +421 484 162 252
parker.slovakia@parker.com

SL – Slovenia, Novo Mesto
Tel: +386 7 337 6650
parker.slovenia@parker.com

TR – Turkey, Istanbul
Tel: +90 216 4997081
parker.turkey@parker.com

UA – Ukraine, Kiev
Tel: +48 (0)22 573 24 00
parker.poland@parker.com

UK – United Kingdom, Warwick
Tel: +44 (0)1926 317 878
parker.uk@parker.com

ZA – South Africa, Kempton Park
Tel: +27 (0)11 961 0700
parker.southafrica@parker.com

North America

CA – Canada, Milton, Ontario
Tel: +1 905 693 3000

US – USA, Cleveland
Tel: +1 216 896 3000

Asia Pacific

AU – Australia, Castle Hill
Tel: +61 (0)2-9634 7777

CN – China, Shanghai
Tel: +86 21 2899 5000

HK – Hong Kong
Tel: +852 2428 8008

IN – India, Mumbai
Tel: +91 22 6513 7081-85

JP – Japan, Tokyo
Tel: +81 (0)3 6408 3901

KR – South Korea, Seoul
Tel: +82 2 559 0400

MY – Malaysia, Shah Alam
Tel: +60 3 7849 0800

NZ – New Zealand, Mt Wellington
Tel: +64 9 574 1744

SG – Singapore
Tel: +65 6887 6300

TH – Thailand, Bangkok
Tel: +662 186 7000

TW – Taiwan, Taipei
Tel: +886 2 2298 8987

South America

AR – Argentina, Buenos Aires
Tel: +54 3327 44 4129

BR – Brazil, Sao Jose dos Campos
Tel: +55 800 727 5374

CL – Chile, Santiago
Tel: +56 2 623 1216

MX – Mexico, Toluca
Tel: +52 72 2275 4200



EMEA Product Information Centre

Free phone: 00 800 27 27 5374

(from AT, BE, CH, CZ, DE, DK, EE, ES, FI, FR, IE, IL, IS, IT, LU, MT, NL, NO, PL, PT, RU, SE, SK, UK, ZA)

US Product Information Centre

Toll-free number: 1-800-27 27 537

www.parker.com

Your local authorized Parker distributor