

aerospace
climate control
electromechanical
filtration
fluid & gas handling
hydraulics
pneumatics
process control
sealing & shielding

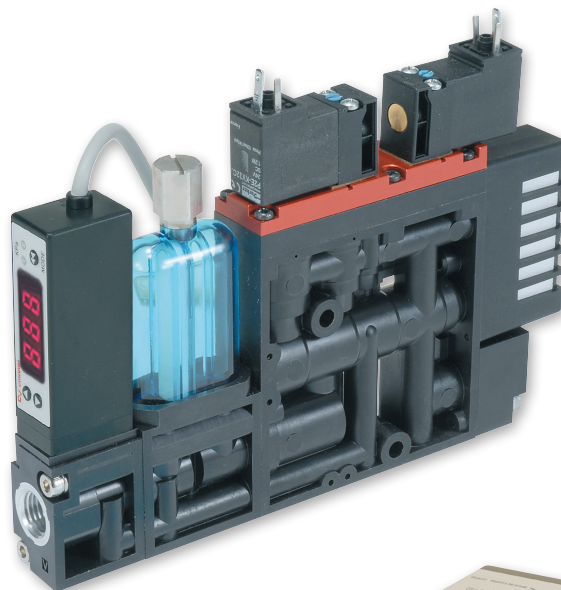
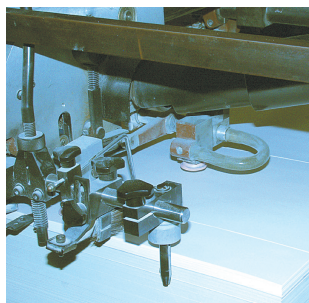

Vacuum Products

Cups, Generators, Sensors & Accessories

Catalog 0802-E



ENGINEERING YOUR SUCCESS.

Distributor Network, Warning, Offer of Sale

DISTRIBUTION NETWORK

At Parker, we have the largest global distribution network in motion and control, with over 7,500 distributors serving more than 422,000 customers. To find the distributor nearest you, please visit our DISTRIBUTOR LOCATOR at <http://www.parker.com/pneu/distributor>



ENGINEERING YOUR SUCCESS.

 **WARNING**

FAILURE OR IMPROPER SELECTION OR IMPROPER USE OF THE PRODUCTS AND/OR SYSTEMS DESCRIBED HEREIN OR RELATED ITEMS CAN CAUSE DEATH, PERSONAL INJURY AND PROPERTY DAMAGE.

This document and other information from Parker Hannifin Corporation, its subsidiaries and authorized distributors provide product and/or system options for further investigation by users having technical expertise. It is important that you analyze all aspects of your application including consequences of any failure, and review the information concerning the product or system in the current product catalog. Due to the variety of operating conditions and applications for these products or systems, the user, through its own analysis and testing, is solely responsible for making the final selection of the products and systems and assuring that all performance, safety and warning requirements of the application are met.

The products described herein, including without limitation, product features, specifications, designs, availability and pricing, are subject to change by Parker Hannifin Corporation and its subsidiaries at any time without notice.

Offer of Sale

The items described in this document are hereby offered for sale by Parker Hannifin Corporation, its subsidiaries or its authorized distributors. This offer and its acceptance are governed by the provisions stated on the separate page of this document entitled "Offer of Sale".

© Copyright 2010 Parker Hannifin Corporation. All Rights Reserved



Parker Hannifin Corporation
Pneumatic Division
Richland, Michigan
www.parker.com/pneumatics

<p>Vacuum Cups</p>	<p>www.parker.com/pneu/vaccup</p>		<p>A Vacuum Cups</p>
<p>Vacuum Generators</p>	<p>www.parker.com/pneu/vacgen</p>		<p>B Generators</p>
<p>Pressure Sensors</p>	<p>www.parker.com/pneu/sensors</p>		<p>C Sensors</p>
<p>Safety Guide, Offer of Sale</p>			<p>D Safety Guide, Offer of Sale</p>

- Think systems – create technical solutions!

A

For paper handling...

For robotic handling...

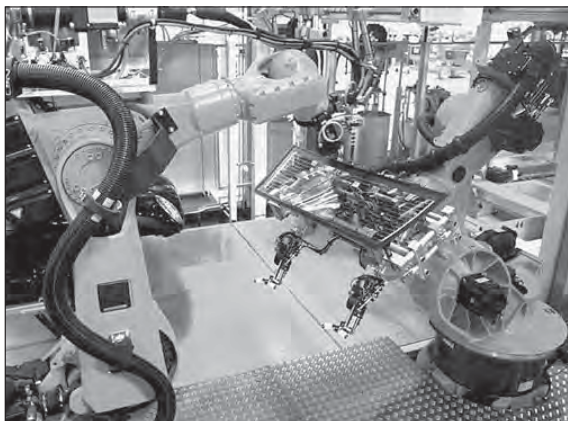
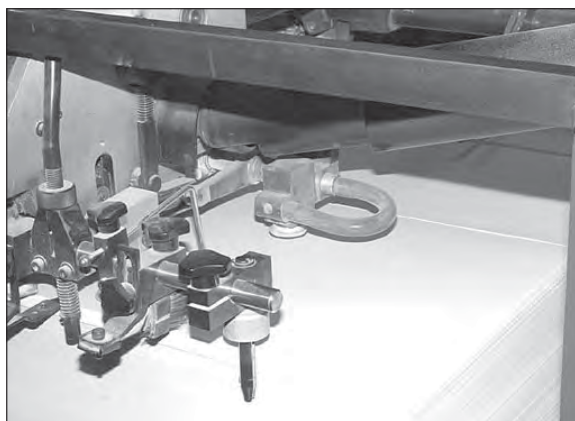
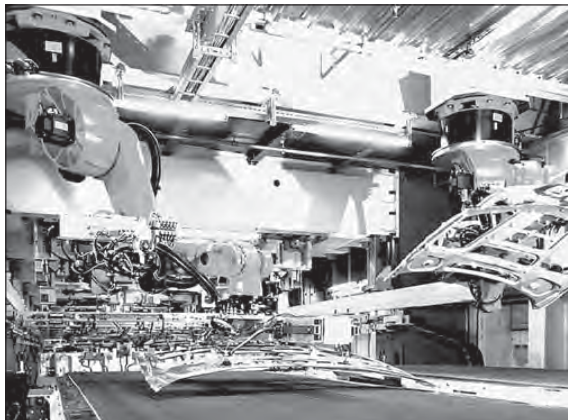
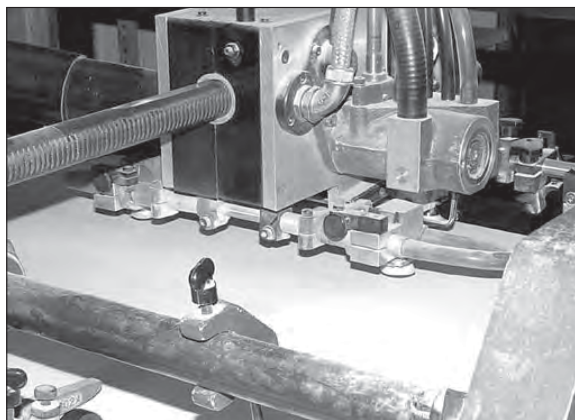

Technical

PFG
Flat

PBG
Bellows

PSV-CFS
Flat

PJG Short
Bellows

PCG
Multiple
Bellows

PUGB
Flat Swivel

Cup
Fittings





Vacuum Cups

A

Section A

www.parker.com/pneu/vaccup









Technical
PFG Flat
PBG Bellows
P5V-CFS Flat
PJG Short Bellows
PCG Multiple Bellows
PUGB Flat Swivel
Cup Fittings



A1

Parker Hannifin Corporation
 Pneumatic Division
 Richland, Michigan
www.parker.com/pneumatics

Index

A Technical PFG Flat PBG Bellows P5V-CFS Flat PJG Short Bellows PCG Multiple Bellows PUGB Flat Swivel Cup Fittings	Technical Information	Lifting Forces, Cup Diameters, Material Specifications	A3 - A5
	PFG Flat	 <p>Precision molded single lip flat cup for smooth or slightly curved surfaces. Low profile design makes flat pads ideal for fast response.</p> <p>Cup Sizes: 5mm to 200mm</p>	A6 - A19
	PBG Bellows	 <p>Versatile bellows cup design provides a flexible sealing lip for products with irregular, smooth, curved surfaces, and flexible products.</p> <p>Cup Sizes: 10mm to 150mm</p>	A20 - A32
	P5V-CFS Flat	 <p>Precision molded double lip flat cup for slightly curved surfaces. Double lip for additional security. If outside lip bends and loses its seal, the inner lip remains sealed. Outer ribs prevent the cup lip from being cut.</p> <p>Cup Sizes: 50mm to 300mm</p>	A33
	PJG Short Bellows	 <p>Versatile bellows cup design provides a flexible sealing lip for products with irregular, smooth, curved surfaces, and slightly flexible products. Shorter stroke provides fast response.</p> <p>Cup Sizes: 6mm to 80mm</p>	A34 - A47
	PCG Multiple Bellows	 <p>Versatile bellows cup design provides a flexible sealing lip for products with irregular, smooth, or curved surfaces. 2-1/2 bellows design minimizes contact pressure applied to products.</p> <p>Cup Sizes: 5mm to 90mm</p>	A48 - A58
	PUGB Flat Swivel	 <p>30° swivel single lip flat cup for smooth surfaces, slightly curved surfaces, and flexible products. Rigid stem or level compensator provides good stability for horizontal lift.</p> <p>Cup Sizes: 60mm to 100mm</p>	A59 - A63
Cup Screws	Cup screws.	A64	
Cup Fitting Assemblies	Cup / Fitting Cross Reference.	A64 - A68	



Specifications

Cup material should be considered for temperature resistance, chemical resistance, oil resistance, abrasion resistance, markless properties and electrical properties.

	NBR	NBRE	CR	SI	SIE	U
Suction cup material	Nitrile	Nitrile ESD*	Chloroprene	Silicon	Silicon ESD*	Urethane
Operating temperature (°C)	-20° to +120°	0° to +60°	-30° to +140°	-60° to +250°	-10° to +130°	-20° to +75°
Color	Black	Black / Blue Dot	Green	White	Black / Red Dot	Blue
Hardness, shore A (°Sh)	55 ±5	70 ±5	55 ±5	55 ±5	55 ±5	55 ±5
Electrical resistance (Ωm)	—	800 to 1000	—	—	5 to 15	—
Wear resistance	•••••	•••••	•••••	••	••	••••••
Tear strength	••••	••••	•••••	•	•	••••••
Aging resistance	••••	••••	•••••	••••••	••••••	••••••
Ozone resistance	••••	••••	•••••	••••••	••••••	••••••
Gasoline resistance	••••••	••••••	•••••	••••	••••	••••••
Oil resistance	••••••	••••••	•••••	••••••	••••••	•••••
Acid resistance	•••	•••	•••••	•••	•••	•
Alkali resistance	••••	••••	•••••	•••	•••	•
Chemical resistance	•••	•••	••••	••	••	••••••
Mechanical resistance	••••	••••	••••	••••	••••	•••••

•••••• = excellent; ••••• = very good; ••••• = good; •••• = medium; •• = poor; • = not recommended

* ESD: Electric Static Dissipative Material

A
Technical
PFG Flat
PBG Bellows
P5V-CFS Flat
PJG Short Bellows
PCG Multiple Bellows
PUGB Flat Swivel
Cup Fittings

A
Technical
PFG Flat
PBG Bellows
P5V-CFS Flat
PUG Short Bellows
PCG Multiple Bellows
PUGB Flat Swivel
Cup Fittings

Selecting the proper vacuum cup

⚠ CAUTION:

Selecting the type of vacuum cup, material, and size suitable for an application is important to the overall vacuum system. Calculating the forces involved for each application is recommended to determine the vacuum cup size. It should be noted that these calculations are basic theoretical guidelines and each application must be tested for actual results. With all vacuum applications, certain practical assumptions concerning cup materials, environmental conditions, and product characteristics to name a few, may not be consistent with the performance. Again, the user should determine the efficiency, performance, and safety factor of the cup selection.

Calculating pad diameter and forces

Mass

The term mass is a quantity of matter and its ability to resist motion when acted on by an external force. The magnitude of an object is represented as a certain number of kilograms (kg) and is symbolized as "m". The easiest way to determine the mass of an object is to measure the weight with a scale within the earth's gravitational field ($a_g = 9.81 \text{ m/sec}^2$). Likewise, outside of any gravitational field, a mass could potentially be weightless.

Forces

For vacuum applications, force is a vector quantity in a defined direction either horizontal or vertical. The standard international unit of force is measured in Newtons (N) which is the equivalent of (kgm/sec^2). The force can be calculated by measuring the effect of a change in acceleration on a mass.

Newton's Law: $F(N) = \text{mass}(\text{kg}) \times a_g(\text{m/sec}^2)$

Consider an object with a mass of 10kg. The gravitational force on this object would be:

$$F(N) = 10\text{kg} \times 9.81\text{m/sec}^2 = 98.1 \text{ N}$$

Acceleration

Acceleration is the change in velocity of a moving object. Acceleration is a vector, a directional quantity expressed in units of meters per second squared (m/sec^2) and symbolized as "a". To explain the magnitude of acceleration consider an object with a change in velocity of 2 meters per second (m/sec) over a 4 second time frame. The acceleration can be calculated with:

$$a = \frac{\Delta \text{ velocity}}{\text{time}} \quad a = \frac{6\text{m/sec}}{2 \text{ sec}} \quad a = 3\text{m/sec}^2$$

This is considered an average acceleration.

Coefficient of friction

Certain values for coefficient of friction should be taken into consideration when calculating the combined forces in motion. Actual values between suction cups and surfaces are difficult to determine. Therefore, coefficient of friction values from published charts, should be used as a reference to adjust the safety factors accordingly.

Lifting forces

When calculating lifting forces, safety factors of 2 for horizontal lifts and 4 for vertical lifts are minimum values. Applications with irregular shapes, difficult surfaces, and backward motions will require increased safety factors.

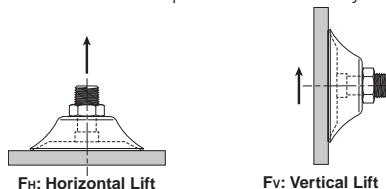

Horizontal lifting force

Apply Newton's Law to calculate the force on a 10kg mass with a change in acceleration of 3m/sec^2 and a safety factor of 2.

$$FH(N) = \text{mass}(\text{kg}) \times (a_g + a) \times SH$$

$$FH(N) = 10\text{kg} \times (9.81\text{m/sec}^2 + 3\text{m/sec}^2) \times 2$$

$$FH = 256.2 \text{ N}$$

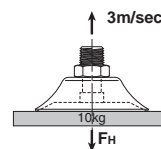

Vertical lifting force

Apply Newton's Law to calculate the force on a 10kg mass with a dry surface, a change in acceleration of 3m/sec^2 and a safety factor of 4.

$$FV(N) = \text{mass}(\text{kg}) \times (a_g + a) \times Sv$$

$$FV(N) = 10\text{kg} \times (9.81\text{m/sec}^2 + 3\text{m/sec}^2) \times 4$$

$$FV = 512.4 \text{ N}$$

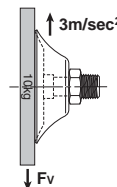

Combined vertical lift and horizontal motion

Calculate the force on a 10kg mass with a dry surface, a change in acceleration of 3m/sec^2 , and a change in travel acceleration of 2m/sec^2 .

$$FM(N) = \sqrt{FV^2 + FH^2}$$

$$FM(N) = \sqrt{[(10\text{kg} \times 2\text{m/sec}^2) \times 4]^2 + [10\text{kg} \times (9.81\text{m/sec}^2 + 3\text{m/sec}^2) \times 2]^2}$$

$$FM(N) = \sqrt{(80\text{kgm/sec}^2)^2 + [256\text{kgm/sec}^2]^2}$$

$$FM(N) = \sqrt{6400\text{kgm/sec}^2 + 65,536\text{kgm/sec}^2}$$

$$FM = 268.2 \text{ N}$$

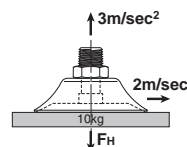

Catalog 0802-E
Lift Capacity

Analyze the forces

Using the previous examples, consider an application where 4 cups have been selected to transfer the product.

Take the Horizontal Lifting Force (FH) of 256.2 N and divide by the number of cups (4) to obtain the individual force for each cup.

$$\frac{256.2 \text{ (N)}}{4} = 64.05 \text{ N / Cup}$$

Referring to the chart below, at 60% vacuum, select a force greater than 64.05 N. The appropriate selection is a 40mm diameter cup which has a theoretical lifting force of 76.9 N.

The same calculation can be applied to the Vertical Lifting Force and the Forces in Motion examples to determine the cup diameter.

To convert Pounds (lbf) to Newton (N), multiply lbf x 4.4.

Theoretical lifting force per cup lbf (N)

Cup		Vacuum level								
Diameter mm	Area cm ²	3 inHg	6 inHg	9 inHg	12 inHg	15 inHg	18 inHg	21 inHg	24 inHg	27 inHg
		-1.5 PSIG	-3 PSIG	-4.5 PSIG	-6 PSIG	-7.5 PSIG	-9 PSIG	-10.5 PSIG	-12 PSIG	-13.5 PSIG
		10.2 kPa	20.3 kPa	30.5 kPa	40.6 kPa	50.8 kPa	61 kPa	71.1 kPa	81.3 kPa	91.4 kPa
		10%	20%	30%	40%	50%	60%	70%	80%	90%
1.5	0.01	0.004 (0.02)	0.008 (0.04)	0.008 (0.04)	0.014 (0.06)	0.018 (0.08)	0.022 (0.10)	0.026 (0.12)	0.032 (0.14)	0.032 (0.14)
2	0.03	0.007 (0.03)	0.013 (0.06)	0.022 (0.10)	0.029 (0.13)	0.036 (0.16)	0.043 (0.19)	0.049 (0.22)	0.056 (0.25)	0.063 (0.28)
3.5	0.10	0.022 (0.10)	0.045 (0.20)	0.065 (0.29)	0.088 (0.39)	0.110 (0.49)	0.133 (0.59)	0.155 (0.69)	0.175 (0.78)	0.198 (0.88)
5	0.20	0.045 (0.20)	0.090 (0.40)	0.135 (0.60)	0.180 (0.80)	0.225 (1.00)	0.270 (1.20)	0.315 (1.40)	0.360 (1.60)	0.405 (1.80)
6	0.28	0.065 (0.29)	0.130 (0.58)	0.196 (0.87)	0.270 (1.20)	0.315 (1.40)	0.382 (1.70)	0.450 (2.00)	0.517 (2.30)	0.585 (2.60)
7	0.39	0.088 (0.39)	0.175 (0.78)	0.265 (1.18)	0.360 (1.60)	0.450 (2.00)	0.540 (2.40)	0.607 (2.70)	0.697 (3.10)	0.787 (3.50)
8	0.50	0.117 (0.52)	0.229 (1.02)	0.346 (1.54)	0.450 (2.00)	0.585 (2.60)	0.697 (3.10)	0.809 (3.60)	0.922 (4.10)	1.034 (4.60)
10	0.79	0.180 (0.80)	0.360 (1.60)	0.540 (2.40)	0.719 (3.20)	0.899 (4.00)	1.079 (4.80)	1.259 (5.60)	1.439 (6.40)	1.619 (7.20)
15	1.77	0.404 (1.80)	0.809 (3.60)	1.216 (5.41)	1.619 (7.20)	2.023 (9.00)	2.428 (10.8)	2.833 (12.6)	3.237 (14.4)	3.642 (16.2)
18	2.55	0.585 (2.60)	1.169 (5.20)	1.751 (7.79)	2.338 (10.4)	2.923 (13.0)	3.507 (15.6)	4.069 (18.1)	4.676 (20.8)	5.238 (23.3)
20	3.14	0.719 (3.20)	1.439 (6.40)	2.158 (9.60)	2.878 (12.8)	3.597 (16.0)	4.316 (19.2)	5.036 (22.4)	5.755 (25.6)	6.474 (28.8)
25	4.91	1.124 (5.00)	2.248 (10.0)	3.372 (15.0)	4.496 (20.0)	5.620 (25.0)	6.744 (30.0)	7.868 (35.0)	8.992 (40.0)	10.116 (45.0)
30	7.07	1.619 (7.20)	3.237 (14.4)	4.856 (21.6)	6.474 (28.8)	8.093 (36.0)	9.712 (43.2)	11.330 (50.4)	12.949 (57.6)	14.568 (64.8)
35	9.62	2.203 (9.80)	4.406 (19.6)	6.609 (29.4)	8.813 (39.2)	11.016 (49.0)	13.241 (58.9)	15.422 (68.6)	17.648 (78.5)	19.828 (88.2)
40	12.6	2.900 (12.9)	5.755 (25.6)	8.655 (38.5)	11.510 (51.2)	14.388 (64.0)	17.288 (76.9)	20.143 (89.6)	23.155 (103)	25.853 (115)
50	19.6	4.519 (20.1)	8.992 (40.0)	13.511 (60.1)	17.985 (80.0)	22.481 (100)	26.977 (120)	31.473 (140)	35.969 (160)	40.466 (180)
60	28.3	6.497 (28.9)	12.949 (57.6)	19.446 (86.5)	25.853 (115)	32.372 (144)	38.892 (173)	45.411 (202)	51.931 (231)	58.226 (259)
75	44.2	10.161 (45.2)	20.233 (90.0)	30.349 (135)	40.466 (180)	50.582 (225)	60.698 (270)	70.815 (315)	80.931 (360)	91.048 (405)
80	50.3	11.555 (51.4)	22.931 (102)	34.621 (154)	46.086 (205)	57.551 (256)	69.241 (308)	80.706 (359)	92.172 (410)	103.637 (461)
90	63.6	14.635 (65.1)	29.225 (130)	43.838 (195)	58.226 (259)	72.838 (324)	87.451 (389)	102.063 (454)	116.676 (519)	131.064 (583)
95	70.9	16.299 (72.5)	32.372 (144)	48.784 (217)	64.970 (289)	81.156 (361)	97.567 (434)	113.753 (506)	129.940 (578)	146.126 (650)
110	95.0	21.851 (97.2)	43.613 (194)	65.419 (291)	87.001 (387)	108.808 (484)	130.614 (581)	152.421 (678)	174.227 (775)	195.809 (871)
120	113.1	26.078 (116)	51.706 (230)	77.784 (346)	103.637 (461)	129.490 (576)	155.568 (692)	181.421 (807)	207.274 (922)	233.127 (1037)
150	176.7	40.690 (181)	80.931 (360)	121.622 (541)	161.862 (720)	202.328 (900)	243.019 (1081)	283.259 (1260)	323.950 (1441)	364.191 (1620)
200	314.2	72.164 (321)	143.878 (640)	216.041 (961)	287.531 (1279)	359.919 (1601)	432.083 (1922)	503.797 (2241)	575.961 (2562)	647.449 (2880)

Vacuum Cups
Technical Information

Calculate the diameter of the cup

Calculate the cup diameter for horizontal lift at 60% of full vacuum using the information from the previous page.

$$D = 35.7 \sqrt{\frac{m(a_g + a) \times S}{P_v \times n}}$$

D (mm) = Diameter of Cup
 m (kg) = Mass
 $a_g = 9.81 \text{ m/sec}^2$
 a = Motion Acceleration
 S = Safety Factor
 P_v (kPa) = Operating Vacuum Pressure
 n = number of Cups

$$D = 35.7 \sqrt{\frac{10(9.81 + 3) \times 2}{61 \times 4}}$$

D = 36.58 mm

Referring to the chart below, at 60% vacuum, select a cup diameter equal to or greater than 37mm. The appropriate selection is a 40mm diameter cup which has a theoretical lifting force of 76.9 N.

A
Technical
PFG Flat
PBG Bellows
P5V-CFS Flat
PJG Short Bellows
PCG Multiple Bellows
PUGB Flat Swivel
Cup Fittings



Features
A

Exceptional for any smooth flat or surface that will benefit from stability and fast response of the cup design. This is a multi-versatile and multi-industry cup. Typical applications could be chip mounting, electrical components, semiconductor chips, glass, injection mold, sheet metal, press transfer, fixtures, woodworking.

Features

- Precision molded single lip flat cup for smooth or slightly curved surfaces.
- Universal flat design for most smooth surface applications
- Stable vertical / horizontal lift
- Strong low profile design for fast response needed for short cycles
- 5mm to 200mm diameters
- Bottom cleats on 60 to 200mm diameters

Styles

- PFTM series male thread connector
- PFTF series female thread connector
- PFTK series barbed bulkhead
- PFYK series 90° barbed adapter
- PFTYS series bulkhead level compensator

Specifications

Cup material	Nitrile	Nitrile ESD*	Silicon	Silicon ESD*	Urethane
Material code	NBR	NBRE	SI	SIE	U
Operating temperature (°C)	-20° to +120°	0° to +60°	-60° to +250°	-10° to +130°	-20° to +75°
Color	Black	Black / Blue Dot	White	Black / Red Dot	Blue
Hardness, shore A (°Sh)	55 ±5	70 ±5	55 ±5	55 ±5	55 ±5
Electrical resistance (Ωm)	—	800 to 1000	—	5 to 15	—

* ESD: Electric Static Dissipative Material

How to order

Cups Assemblies and replacement cups are specified by Cup Diameter and Material. Standard Nitrile and silicon are listed on the following pages. To specify an alternative material, replace the cup material with alternative cup material code.

Example: To specify a cup assembly with Urethane (U), replace (NBR) with (U) in the part number. PFTM-20B-NBR-G1 becomes PFTM-20B-U-G1. Inquire with factory for availability.

Application guide
Flat - Smooth surface

Ø 120/200 only

Flat surface, thin section

Flat surface, any section

Slightly bowed surface, thin section

Slightly bowed surface, any section

Metal sheet handling

Corrugated sheet handling

High lifting force

Vertical lift



A6

Parker Hannifin Corporation
 Pneumatic Division
 Richland, Michigan
www.parker.com/pneumatics

PFTM Series Male Thread Connector

Simple male connection for low profile positions secured to a plate or bracket. NPT, G, metric threads.
Fitting material: aluminum.

Installation

Note:

When installing cup assemblies, use a sealant material to secure the assembly and prevent vacuum leakage.

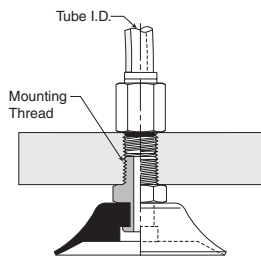

Cup diameter (mm)	Vacuum port	Complete assembly Nitrile (NBR)	Replacement cup Nitrile (NBR)	Complete assembly Silicon (SI)	Replacement cup Silicon (SI)	Replacement cup fitting
5	M5	PFTM-5A-NBR-M5	PFG-5A-NBR	PFTM-5A-SI-M5	PFG-5A-SI	FTM-5A-M5H
5	1/8 BSPP	PFTM-5A-NBR-G1	PFG-5A-NBR	PFTM-5A-SI-G1	PFG-5A-SI	FTM-5A-G1
6	M5	PFTM-6A-NBR-M5	PFG-6A-NBR	PFTM-6A-SI-M5	PFG-6A-SI	FTM-5A-M5H
6	1/8 BSPP	PFTM-6A-NBR-G1	PFG-6A-NBR	PFTM-6A-SI-G1	PFG-6A-SI	FTM-5A-G1
8	M5	PFTM-8A-NBR-M5	PFG-8A-NBR	PFTM-8A-SI-M5	PFG-8A-SI	FTM-5A-M5H
8	1/8 BSPP	PFTM-8A-NBR-G1	PFG-8A-NBR	PFTM-8A-SI-G1	PFG-8A-SI	FTM-5A-G1
10	M5	PFTM-10A-NBR-M5	PFG-10A-NBR	PFTM-10A-SI-M5	PFG-10A-SI	FTM-5A-M5H
10	1/8 BSPP	PFTM-10A-NBR-G1	PFG-10A-NBR	PFTM-10A-SI-G1	PFG-10A-SI	FTM-5A-G1
15	M5	PFTM-15A-NBR-M5	PFG-15A-NBR	PFTM-15A-SI-M5	PFG-15A-SI	FTM-5A-M5H
15	1/8 BSPP	PFTM-15A-NBR-G1	PFG-15A-NBR	PFTM-15A-SI-G1	PFG-15A-SI	FTM-5A-G1
20	1/8 BSPP	PFTM-20B-NBR-G1	PFG-20B-NBR	PFTM-20B-SI-G1	PFG-20B-SI	FTM-20B-G1H
20	1/4 BSPP	PFTM-20B-NBR-G2	PFG-20B-NBR	PFTM-20B-SI-G2	PFG-20B-SI	FTM-20B-G2
20	M10	PFTM-20B-NBR-M10	PFG-20B-NBR	PFTM-20B-SI-M10	PFG-20B-SI	FTM-20B-M10
20	1/8 NPT	PFTM-20B-NBR-N1	PFG-20B-NBR	PFTM-20B-SI-N1	PFG-20B-SI	FTM-20B-N1
30	1/8 BSPP	PFTM-30-NBR-G1	PFG-30-NBR	PFTM-30-SI-G1	PFG-30-SI	FTM-20B-G1H
30	1/4 BSPP	PFTM-30-NBR-G2	PFG-30-NBR	PFTM-30-SI-G2	PFG-30-SI	FTM-20B-G2
30	M10	PFTM-30-NBR-M10	PFG-30-NBR	PFTM-30-SI-M10	PFG-30-SI	FTM-20B-M10
30	1/8 NPT	PFTM-30-NBR-N1	PFG-30-NBR	PFTM-30-SI-N1	PFG-30-SI	FTM-20B-N1
40	1/8 BSPP	PFTM-40-NBR-G1	PFG-40-NBR	PFTM-40-SI-G1	PFG-40-SI	FTM-20B-G1H
40	1/4 BSPP	PFTM-40-NBR-G2	PFG-40-NBR	PFTM-40-SI-G2	PFG-40-SI	FTM-20B-G2
40	M10	PFTM-40-NBR-M10	PFG-40-NBR	PFTM-40-SI-M10	PFG-40-SI	FTM-20B-M10
40	1/8 NPT	PFTM-40-NBR-N1	PFG-40-NBR	PFTM-40-SI-N1	PFG-40-SI	FTM-20B-N1
50	1/8 BSPP	PFTM-50-NBR-G1	PFG-50-NBR	PFTM-50-SI-G1	PFG-50-SI	FTM-50-G1H
50	1/4 BSPP	PFTM-50-NBR-G2	PFG-50-NBR	PFTM-50-SI-G2	PFG-50-SI	FTM-50-G2
50	1/8 NPT	PFTM-50-NBR-N1	PFG-50-NBR	PFTM-50-SI-N1	PFG-50-SI	FTM-50-N1
60	1/4 BSPP	PFTM-60-NBR-G2	PFG-60-NBR	PFTM-60-SI-G2	PFG-60-SI	FTM-60-G2
60	M10	PFTM-60-NBR-M10	PFG-60-NBR	PFTM-60-SI-M10	PFG-60-SI	FTM-60-M10
60	1/4 NPT	PFTM-60-NBR-N2	PFG-60-NBR	PFTM-60-SI-N2	PFG-60-SI	FTM-60-N2
80	1/4 BSPP	PFTM-80-NBR-G2	PFG-80-NBR	PFTM-80-SI-G2	PFG-80-SI	FTM-60-G2
80	M10	PFTM-80-NBR-M10	PFG-80-NBR	PFTM-80-SI-M10	PFG-80-SI	FTM-60-M10
80	1/4 NPT	PFTM-80-NBR-N2	PFG-80-NBR	PFTM-80-SI-N2	PFG-80-SI	FTM-60-N2
95	1/4 BSPP	PFTM-95-NBR-G2	PFG-95-NBR	PFTM-95-SI-G2	PFG-95-SI	FTM-60-G2
95	M10	PFTM-95-NBR-M10	PFG-95-NBR	PFTM-95-SI-M10	PFG-95-SI	FTM-60-M10
95	1/4 NPT	PFTM-95-NBR-N2	PFG-95-NBR	PFTM-95-SI-N2	PFG-95-SI	FTM-60-N2

Most popular.

A

Technical

PFG Flat

PBG Bellows

P5V-CFS Flat

PJG Short Bellows

PCG Multiple Bellows

PUGB Flat Swivel

Cup Fittings



A

Technical

PFG Flat

PBG Bellows

P5V-CFS Flat

PJG Short Bellows

PCG Multiple Bellows

PUGB Flat Swivel

Cup Fittings

PFTF Series Female Thread Connector

Simple female connection for low profile positions secured to a plate or bracket. NPSF, G threads. Fitting material: aluminum.

Installation

Note:

When installing cup assemblies, use a sealant material to secure the assembly and prevent vacuum leakage.

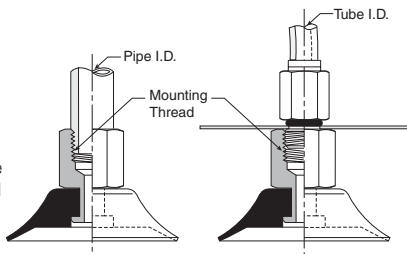

Cup diameter (mm)	Vacuum port	Complete assembly Nitrile (NBR)	Replacement cup Nitrile (NBR)	Complete assembly Silicon (SI)	Replacement cup Silicon (SI)	Replacement cup fitting
5	M5	PFTF-5A-NBR-M5	PFG-5A-NBR	PFTF-5A-SI-M5	PFG-5A-SI	FTF-5A-M5
5	1/8 BSPP	PFTF-5A-NBR-G1	PFG-5A-NBR	PFTF-5A-SI-G1	PFG-5A-SI	FTF-5A-G1
6	M5	PFTF-6A-NBR-M5	PFG-6A-NBR	PFTF-6A-SI-M5	PFG-6A-SI	FTF-5A-M5
6	1/8 BSPP	PFTF-6A-NBR-G1	PFG-6A-NBR	PFTF-6A-SI-G1	PFG-6A-SI	FTF-5A-G1
8	M5	PFTF-8A-NBR-M5	PFG-8A-NBR	PFTF-8A-SI-M5	PFG-8A-SI	FTF-5A-M5
8	1/8 BSPP	PFTF-8A-NBR-G1	PFG-8A-NBR	PFTF-8A-SI-G1	PFG-8A-SI	FTF-5A-G1
10	1/8 BSPP	PFTF-10A-NBR-G1	PFG-10A-NBR	PFTF-10A-SI-G1	PFG-10A-SI	FTF-5A-G1
10	M5	PFTF-10A-NBR-M5	PFG-10A-NBR	PFTF-10A-SI-M5	PFG-10A-SI	FTF-5A-M5
15	1/8 BSPP	PFTF-15A-NBR-G1	PFG-15A-NBR	PFTF-15A-SI-G1	PFG-15A-SI	FTF-5A-G1
15	M5	PFTF-15A-NBR-M5	PFG-15A-NBR	PFTF-15A-SI-M5	PFG-15A-SI	FTF-5A-M5
20	1/8 BSPP	PFTF-20B-NBR-G1	PFG-20B-NBR	PFTF-20B-SI-G1	PFG-20B-SI	FTF-20B-G1
30	1/8 BSPP	PFTF-30-NBR-G1	PFG-30-NBR	PFTF-30-SI-G1	PFG-30-SI	FTF-20B-G1
30	1/4 BSPP	PFTF-30-NBR-G2	PFG-30-NBR	PFTF-30-SI-G2	PFG-30-SI	FTF-20B-G2
40	1/8 BSPP	PFTF-40-NBR-G1	PFG-40-NBR	PFTF-40-SI-G1	PFG-40-SI	FTF-20B-G1
40	1/4 BSPP	PFTF-40-NBR-G2	PFG-40-NBR	PFTF-40-SI-G2	PFG-40-SI	FTF-20B-G2
50	1/8 BSPP	PFTF-50-NBR-G1	PFG-50-NBR	PFTF-50-SI-G1	PFG-50-SI	FTF-50-G1
50	1/4 BSPP	PFTF-50-NBR-G2	PFG-50-NBR	PFTF-50-SI-G2	PFG-50-SI	FTF-50-G2
60	1/4 BSPP	PFTF-60-NBR-G2	PFG-60-NBR	PFTF-60-SI-G2	PFG-60-SI	FTF-60-G2
60	1/4 NPT	PFTF-60-NBR-N2	PFG-60-NBR	PFTF-60-SI-N2	PFG-60-SI	FTF-60-N2
80	1/4 BSPP	PFTF-80-NBR-G2	PFG-80-NBR	PFTF-80-SI-G2	PFG-80-SI	FTF-60-G2
80	1/4 NPT	PFTF-80-NBR-N2	PFG-80-NBR	PFTF-80-SI-N2	PFG-80-SI	FTF-60-N2
95	1/4 NPT	PFTF-95-NBR-N2	PFG-95-NBR	PFTF-95-SI-N2	PFG-95-SI	FTF-60-N2
95	1/4 BSPP	PFTF-95-NBR-G2	PFG-95-NBR	PFTF-95-SI-G2	PFG-95-SI	FTF-60-G2
120	1/2 BSPP	PFTF-120-NBR-G4	PFG-120-NBR	PFTF-120-SI-G4	PFG-120-SI	FTF-120-G4
120	1/2 NPT	PFTF-120-NBR-N4	PFG-120-NBR	PFTF-120-SI-N4	PFG-120-SI	FTF-120-N4
150	1/2 NPT	PFTF-150-NBR-G4	PFG-150-NBR	PFTF-150-SI-G4	PFG-150-SI	FTF-120-G4
150	1/2 NPT	PFTF-150-NBR-N4	PFG-150-NBR	PFTF-150-SI-N4	PFG-150-SI	FTF-120-N4
200	1/2 BSPP	PFTF-200-NBR-G4	PFG-200-NBR	PFTF-200-SI-G4	PFG-200-SI	FTF-120-G4
200	1/2 NPT	PFTF-200-NBR-N4	PFG-200-NBR	PFTF-200-SI-N4	PFG-200-SI	FTF-120-N4

☐ Most popular.



PFTK Series Barbed Bulkhead

Top stem connectors secured with jam nuts and allow tubing connections at the top side. Fitting material: nickel plated brass.

Installation

Note:

When installing cup assemblies, use a sealant material to secure the assembly and prevent vacuum leakage.

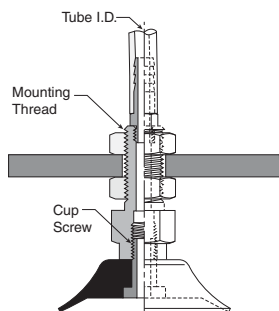

Cup diameter (mm)	Vacuum port	Complete assembly Nitrile (NBR)	Replacement cup Nitrile (NBR)	Complete assembly Silicon (SI)	Replacement cup Silicon (SI)	Replacement cup fitting
5	Barb	PFTK-5A-NBR	PFG-5A-NBR	PFTK-5A-SI	PFG-5A-SI	FTK-5A
6	Barb	PFTK-6A-NBR	PFG-6A-NBR	PFTK-6A-SI	PFG-6A-SI	FTK-5A
8	Barb	PFTK-8A-NBR	PFG-8A-NBR	PFTK-8A-SI	PFG-8A-SI	FTK-5A
10	Barb	PFTK-10A-NBR	PFG-10A-NBR	PFTK-10A-SI	PFG-10A-SI	FTK-5A
15	Barb	PFTK-15-NBR	PFG-15-NBR	PFTK-15-SI	PFG-15-SI	FTK-15
20	Barb	PFTK-20-NBR	PFG-20-NBR	PFTK-20-SI	PFG-20-SI	FTK-20
30	Barb	PFTK-30-NBR	PFG-30-NBR	PFTK-30-SI	PFG-30-SI	FTK-25
40	Barb	PFTK-40-NBR	PFG-40-NBR	PFTK-40-SI	PFG-40-SI	FTK-25
50	Barb	PFTK-50-NBR	PFG-50-NBR	PFTK-50-SI	PFG-50-SI	FTK-50
60	1/8 BSPP	PFTK-60-NBR-G1	PFG-60-NBR	PFTK-60-SI-G1	PFG-60-SI	FTK-60-G1
60	1/8 NPT	PFTK-60-NBR-N1	PFG-60-NBR	PFTK-60-SI-N1	PFG-60-SI	FTK-60-N1
80	1/8 BSPP	PFTK-80-NBR-G1	PFG-80-NBR	PFTK-80-SI-G1	PFG-80-SI	FTK-60-G1
80	1/8 NPT	PFTK-80-NBR-N1	PFG-80-NBR	PFTK-80-SI-N1	PFG-80-SI	FTK-60-N1
95	1/8 BSPP	PFTK-95-NBR-G1	PFG-95-NBR	PFTK-95-SI-G1	PFG-95-SI	FTK-60-G1
95	1/8 NPT	PFTK-95-NBR-N1	PFG-95-NBR	PFTK-95-SI-N1	PFG-95-SI	FTK-60-N1

A
Technical
PFG Flat
PBG Bellows
P5V-CFS Flat
PJG Short Bellows
PCG Multiple Bellows
PUGB Flat Swivel
Cup Fittings

Most popular.



PFYK Series 90° Barbed Adapter

Side stem connectors allow you to secure the stem with a bolt thru a plate or "L" bracket to allow the tube connection from the side port. Fitting material: nickel plated brass.

Installation
Note:

When installing cup assemblies, use a sealant material to secure the assembly and prevent vacuum leakage.

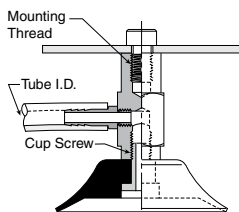

Cup diameter (mm)	Vacuum port	Complete assembly Nitrile (NBR)	Replacement cup Nitrile (NBR)	Complete assembly Silicon (SI)	Replacement cup Silicon (SI)	Replacement cup fitting
5	Barb	PFYK-5A-NBR	PFG-5A-NBR	PFYK-5A-SI	PFG-5A-SI	FYK-5A
6	Barb	PFYK-6A-NBR	PFG-6A-NBR	PFYK-6A-SI	PFG-6A-SI	FYK-5A
8	Barb	PFYK-8A-NBR	PFG-8A-NBR	PFYK-8A-SI	PFG-8A-SI	FYK-5A
10	Barb	PFYK-10A-NBR	PFG-10A-NBR	PFYK-10A-SI	PFG-10A-SI	FYK-5A
15	Barb	PFYK-15-NBR	PFG-15-NBR	PFYK-15-SI	PFG-15-SI	FYK-15
20	Barb	PFYK-20-NBR	PFG-20-NBR	PFYK-20-SI	PFG-20-SI	FYK-20
30	Barb	PFYK-30-NBR	PFG-30-NBR	PFYK-30-SI	PFG-30-SI	FYK-25
40	Barb	PFYK-40-NBR	PFG-40-NBR	PFYK-40-SI	PFG-40-SI	FYK-25
50	Barb	PFYK-50-NBR	PFG-50-NBR	PFYK-50-SI	PFG-50-SI	FYK-50
60	1/8 BSPP	PFYK-60-NBR-G1	PFG-60-NBR	PFYK-60-SI-G1	PFG-60-SI	FYK-60-G1
60	1/8 NPT	PFYK-60-NBR-N1	PFG-60-NBR	PFYK-60-SI-N1	PFG-60-SI	FYK-60-N1
80	1/8 BSPP	PFYK-80-NBR-G1	PFG-80-NBR	PFYK-80-SI-G1	PFG-80-SI	FYK-60-G1
80	1/8 NPT	PFYK-80-NBR-N1	PFG-80-NBR	PFYK-80-SI-N1	PFG-80-SI	FYK-60-N1
95	1/8 BSPP	PFYK-95-NBR-G1	PFG-95-NBR	PFYK-95-SI-G1	PFG-95-SI	FYK-60-G1
95	1/8 NPT	PFYK-95-NBR-N1	PFG-95-NBR	PFYK-95-SI-N1	PFG-95-SI	FYK-60-N1
120	1/8 BSPP	PFYK-120-NBR-G1	PFG-120-NBR	PFYK-120-SI-G1	PFG-120-SI	FYK-120-G1
120	1/8 NPT	PFYK-120-NBR-N1	PFG-120-NBR	PFYK-120-SI-N1	PFG-120-SI	FYK-120-N1
150	1/8 BSPP	PFYK-150-NBR-G1	PFG-150-NBR	PFYK-150-SI-G1	PFG-150-SI	FYK-120-G1
150	1/8 NPT	PFYK-150-NBR-N1	PFG-150-NBR	PFYK-150-SI-N1	PFG-150-SI	FYK-120-N1
200	1/8 BSPP	PFYK-200-NBR-G1	PFG-200-NBR	PFYK-200-SI-G1	PFG-200-SI	FYK-120-G1
200	1/8 NPT	PFYK-200-NBR-N1	PFG-200-NBR	PFYK-200-SI-N1	PFG-200-SI	FYK-120-N1

Most popular.



Ordering Information

PFTYS Series Bulkhead Level Compensator

303 stainless steel construction secured with jam nuts. Spring biased compensators can absorb impacts of down-strokes and adjust for different levels of pick up points. 303 stainless corrosion resistant materials with drymet bushings increases the strength and life.

Installation

Note:

When installing cup assemblies, use a sealant material to secure the assembly and prevent vacuum leakage.

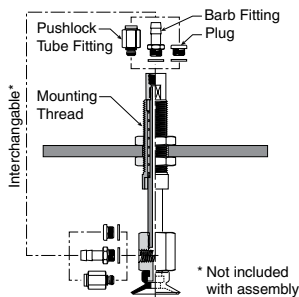

Cup dia. (mm)	Vacuum port	Stroke (mm)	Spring compression Force lbf (N)	0%	100%	Cup material Nitrile assembly (NBR)	Replacement cup Nitrile (NBR)	Cup material Silicon assembly (SI)	Replacement cup Silicon (SI)	Level Compensator P/N
5	M5	10	.14 (.61)	.26 (1.17)		PFTYS5A10NBRM5	PFG-5A-NBR	PFTYS5A10SIM5	PFG-5A-SI	TYS-5A-10
5	M5	15	.15 (.64)	.26 (1.17)		PFTYS5A15NBRM5	PFG-5A-NBR	PFTYS5A15SIM5	PFG-5A-SI	TYS-5A-15
6	M5	10	.14 (.61)	.26 (1.17)		PFTYS6A10NBRM5	PFG-6A-NBR	PFTYS6A10SIM5	PFG-6A-SI	TYS-5A-10
6	M5	15	.15 (.64)	.26 (1.17)		PFTYS6A15NBRM5	PFG-6A-NBR	PFTYS6A15SIM5	PFG-6A-SI	TYS-5A-15
8	M5	10	.14 (.61)	.26 (1.17)		PFTYS8A10NBRM5	PFG-8A-NBR	PFTYS8A10SIM5	PFG-8A-SI	TYS-5A-10
8	M5	15	.15 (.64)	.26 (1.17)		PFTYS8A15NBRM5	PFG-8A-NBR	PFTYS8A15SIM5	PFG-8A-SI	TYS-5A-15
10	M5	10	.11 (.49)	.13 (.59)		PFTYS10A10NBRM5	PFG-10A-NBR	PFTYS10A10SIM5	PFG-10A-SI	TYS-5A-10
10	M5	15	.11 (.49)	.13 (.59)		PFTYS10A15NBRM5	PFG-10A-NBR	PFTYS10A15SIM5	PFG-10A-SI	TYS-5A-15
15	M5	10	.11 (.49)	.13 (.59)		PFTYS15A10NBRM5	PFG-15A-NBR	PFTYS15A10SIM5	PFG-15A-SI	TYS-5A-10
15	M5	15	.11 (.49)	.13 (.59)		PFTYS15A15NBRM5	PFG-15A-NBR	PFTYS15A15SIM5	PFG-15A-SI	TYS-5A-15
20	M5	15	.56 (2.5)	.79 (3.4)		PFTYS20B15NBRM5	PFG-20B-NBR	PFTYS20B15SIM5	PFG-20B-SI	TYS-20B-15
20	M5	30	.56 (2.5)	1.2 (4.9)		PFTYS20B30NBRM5	PFG-20B-NBR	PFTYS20B30SIM5	PFG-20B-SI	TYS-20B-30
30	M5	15	.56 (2.5)	.79 (3.4)		PFTYS3015NBRM5	PFG-30-NBR	PFTYS3015SIM5	PFG-30-SI	TYS-20B-15
30	M5	30	.56 (2.5)	1.2 (4.9)		PFTYS3030NBRM5	PFG-30-NBR	PFTYS3030SIM5	PFG-30-SI	TYS-20B-30
40	M5	15	.56 (2.5)	.79 (3.4)		PFTYS4015NBRM5	PFG-40-NBR	PFTYS4015SIM5	PFG-40-SI	TYS-20B-15
40	M5	30	.56 (2.5)	1.2 (4.9)		PFTYS4030NBRM5	PFG-40-NBR	PFTYS4030SIM5	PFG-40-SI	TYS-20B-30
50	M5	15	.56 (2.5)	1.2 (4.9)		PFTYS5015NBRM5	PFG-50-NBR	PFTYS5015SIM5	PFG-50-SI	TYS-50-15
50	M5	30	.67 (2.9)	1.4 (5.9)		PFTYS5030NBRM5	PFG-50-NBR	PFTYS5030SIM5	PFG-50-SI	TYS-50-30
60	1/8 NPT	30	1.6 (6.8)	3.6 (15.6)		PFTYS6030NBRN1	PFG-60-NBR	PFTYS6030SIN1	PFG-60-SI	TYS-60-30
60	1/8 NPT	50	1.9 (8.3)	4.5 (19.6)		PFTYS6050NBRN1	PFG-60-NBR	PFTYS6050SIN1	PFG-60-SI	TYS-60-50
80	1/8 NPT	30	1.6 (6.8)	3.6 (15.6)		PFTYS8030NBRN1	PFG-80-NBR	PFTYS8030SIN1	PFG-80-SI	TYS-60-30
80	1/8 NPT	50	1.9 (8.3)	4.5 (19.6)		PFTYS8050NBRN1	PFG-80-NBR	PFTYS8050SIN1	PFG-80-SI	TYS-60-50
95	1/8 NPT	30	1.6 (6.8)	3.6 (15.6)		PFTYS9530NBRN1	PFG-95-NBR	PFTYS9530SIN1	PFG-95-SI	TYS-60-30
95	1/8 NPT	50	1.9 (8.3)	4.5 (19.6)		PFTYS9550NBRN1	PFG-95-NBR	PFTYS9550SIN1	PFG-95-SI	TYS-60-50
120	1/4 NPT	20	3.6 (15.6)	6.8 (29)		PFTYS12020NBRN2	PFG-120-NBR	PFTYS12020SIN2	PFG-120-SI	TYS-120-20
120	1/4 NPT	70	3.4 (14.7)	6.8 (29)		PFTYS12070NBRN2	PFG-120-NBR	PFTYS12070SIN2	PFG-120-SI	TYS-120-70
150	1/4 NPT	20	3.6 (15.6)	6.8 (29)		PFTYS15020NBRN2	PFG-150-NBR	PFTYS15020SIN2	PFG-150-SI	TYS-120-20
150	1/4 NPT	70	3.4 (14.7)	6.8 (29)		PFTYS15070NBRN2	PFG-150-NBR	PFTYS15070SIN2	PFG-150-SI	TYS-120-70
200	1/4 NPT	20	3.6 (15.6)	6.8 (29)		PFTYS20020NBRN2	PFG-200-NBR	PFTYS20020SIN2	PFG-200-SI	TYS-120-20
200	1/4 NPT	70	3.4 (14.7)	6.8 (29)		PFTYS20070NBRN2	PFG-200-NBR	PFTYS20070SIN2	PFG-200-SI	TYS-120-70

Most popular.



A
Technical
PFG Flat
PBG Bellows
P5V-CFS Flat
PJG Short Bellows
PCG Multiple Bellows
PUGB Flat Swivel
Cup Fittings

A

Technical

Applications

- Products with smooth surfaces
- Products with minimum flex
- Products that will not permanently deform

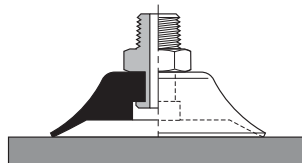
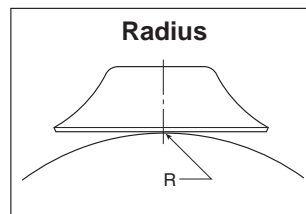
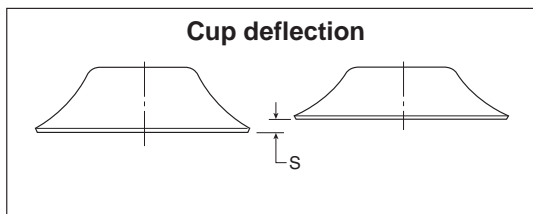
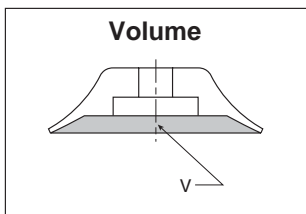
Main data for fat PFG cups

Model number	Cup diameter inches (mm)	Area cm ²	Volume (V) liters	Lifting force @60% (N)		Cup deflection (S) mm	Radius (R) mm
PFG-5A-*	.20 (5)	0.20	0.000005	1.20	0.6	0.5	3.5
PFG-6A-*	.24 (6)	0.28	0.000008	1.70	0.85	1.0	4.0
PFG-8A-*	.31 (8)	0.50	0.00003	3.10	1.5	1.4	5.0
PFG-10A-*	.39 (10)	0.79	0.00007	4.80	2.4	1.5	6.0
PFG-15-*	.59 (15)	1.77	0.0004	10.8	5.4	1.9	6.0
PFG-15A-*	.59 (15)	1.77	0.0004	10.8	5.4	1.9	6.0
PFG-20-*	.79 (20)	3.14	0.0008	19.2	9.6	2.3	9.0
PFG-20B-*	.79 (20)	3.14	0.0008	19.2	9.6	2.3	13.0
PFG-30-*	1.18 (30)	7.07	0.0018	43.2	21.6	2.0	26
PFG-40-*	1.57 (40)	12.60	0.004	76.9	38.5	3.5	37
PFG-50-*	1.97 (50)	19.60	0.007	120	60	4.0	41
PFG-60-*	2.36 (60)	28.30	0.0090	173	87	5.0	70
PFG-80-*	3.15 (80)	50.30	0.025	308	154	6.0	100
PFG-95-*	3.74 (95)	70.90	0.035	434	267	6.0	150
PFG-120-*	4.72 (120)	113.00	0.078	692	346	6.0	365
PFG-150-*	5.91 (150)	176.70	0.177	1081	541	9.0	380
PFG-200-*	7.87 (200)	314.20	0.425	1922	961	13.0	430

* Cup material

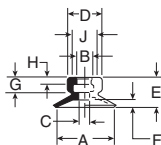
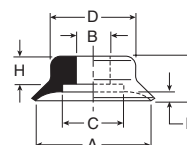
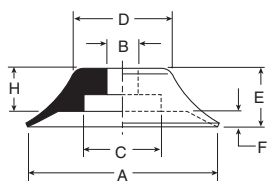
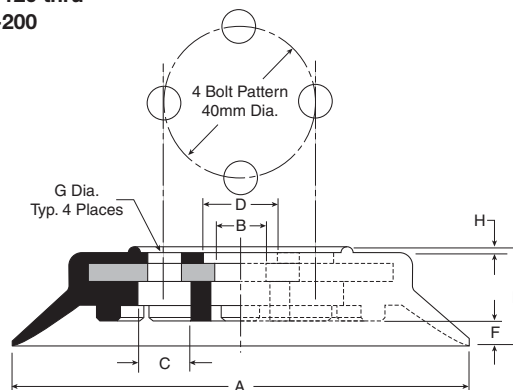
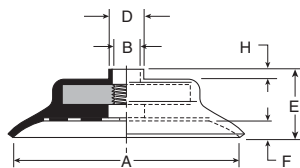
PFG Series Replacement Cup Dimensions
**PFG-5A
PFG-15A**

**PFG-15 thru
PFG-40**

PFG-50

**PFG-120 thru
PFG-200**

**PFG-60 thru
PFG-95**

Model number	ØA	ØB	ØC	ØD	E	F	G	H	ØJ
PFG-5A-*	.20 (5)	.16 (4)	.06 (1.4)	.30 (7.5)	.26 (6.5)	.03 (.8)	.16 (4)	.08 (2)	.24 (6)
PFG-6A-*	.24 (6)	.16 (4)	.08 (2)	.30 (7.5)	.26 (6.5)	.03 (.8)	.16 (4)	.08 (2)	.24 (6)
PFG-8A-*	.31 (8)	.16 (4)	.08 (2)	.31 (8)	.28 (7)	.05 (1.2)	.16 (4)	.08 (2)	.24 (6)
PFG-10A-*	.39 (10)	.16 (4)	.08 (2)	.33 (8.5)	.30 (7.5)	.06 (1.5)	.16 (4)	.08 (2)	.24 (6)
PFG-15-*	.59 (15)	—	.31 (7.8)	.47 (12)	.31 (8)	.07 (1.9)	—	—	—
PFG-15A-*	.59 (15)	.16 (4)	.08 (2)	.35 (9)	.31 (8)	.08 (2)	.16 (4)	.08 (2)	.24 (6)
PFG-20-*	.79 (20)	.18 (4.6)	.43 (11)	.59 (15)	.39 (10)	.09 (2.3)	—	.18 (4.5)	—
PFG-20B-*	.79 (20)	.24 (6)	.43 (11)	.59 (15)	.49 (12.5)	.09 (2.3)	—	.28 (7)	—
PFG-30-*	1.18 (30)	.24 (6)	.43 (11)	.55 (14)	.47 (12)	.08 (2)	—	.28 (7)	—
PFG-40-*	1.57 (40)	.24 (6)	.43 (11)	.94 (24)	.55 (14)	.16 (4)	—	.28 (7)	—
PFG-50-*	1.97(50)	.31 (8)	.79 (20)	1.06 (27)	.59 (15)	.14 (3.5)	—	.28 (7)	—
PFG-60-*	2.36 (60)	M10x1.25	—	.79 (12.5)	.73 (18.5)	.20 (5)	—	.10 (2.5)	—
PFG-80-*	3.15 (80)	M10x1.25	—	.79 (12.5)	.81 (20.5)	.24 (6)	—	.10 (2.5)	—
PFG-95-*	3.74 (95)	M10x1.25	—	.79 (12.5)	.83 (21)	.24 (6)	—	.10 (2.5)	—
PFG-120-*	4.72 (120)	.55 (14)	.55 (14)	.79 (20)	1.00 (25.5)	.24 (6)	4xØ8.7xØ40	.059 (1.5)	—
PFG-150-*	5.91 (150)	.51(13)	.55 (14)	.79 (20)	1.28 (32.5)	.35 (9)	4xØ8.7xØ40	.059 (1.5)	—
PFG-200-*	7.87 (200)	.51 (13)	.47 (12)	.79 (20)	1.48 (37.5)	.51 (13)	4xØ8.7xØ40	.059 (1.5)	—

Inches (mm)

* Cup material

A

Technical

PFG Flat

PBG Bellows

P5V-CFS Flat

PJG Short Bellows

PCG Multiple Bellows

PUGB Flat Swivel

Cup Fittings

- A
- Technical
- PFG
Flat
- PBG
Bellows
- PVG-CFS
Flat
- PUG Short
Bellows
- PCG
Multiple
Bellows
- PUGB
Flat Swivel
- Cup
Fittings

Dimensions

**PFTM-5A thru
PFTM-15A**

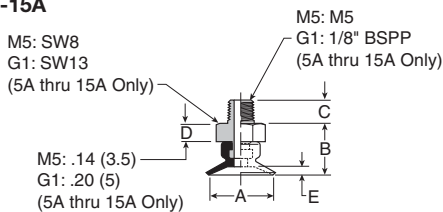

**PFTM-20B thru
PFTM-50**

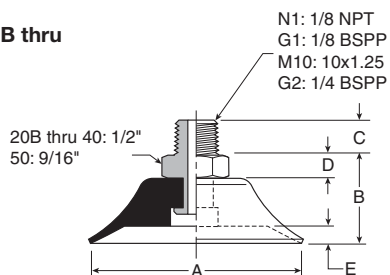

**PFTM-60 thru
PFTM-95**

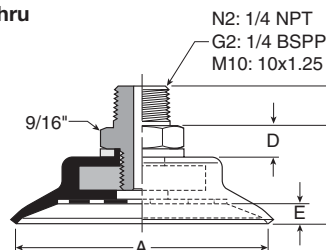

Model number	ØA	B	C (M3)	C (M5)	C (N1 / G1)	C (M10 / G2)	C (N2)	D	E
PFTM-5A-*.†	.20 (5)	.39 (10)	—	.18 (4.5)	.31 (8)	—	—	See Dwg.	.31 (8)
PFTM-6A-*.†	.24 (6)	.39 (10)	—	.18 (4.5)	.31 (8)	—	—	See Dwg.	.31 (8)
PFTM-8A-*.†	.31 (8)	.41 (10.5)	—	.18 (4.5)	.31 (8)	—	—	See Dwg.	.05 (1.2)
PFTM-10A-*.†	.39 (10)	.43 (11)	—	.18 (4.5)	.31 (8)	—	—	See Dwg.	.06 (1.5)
PFTM-15A-*.†	.59 (15)	.45 (11.5)	—	.18 (4.5)	.31 (8)	—	—	See Dwg.	.08 (2)
PFTM-20B-*.†	.79 (20)	.69 (17.5)	—	—	.31 (8)	.39 (10)	—	.20 (5)	.10 (2.5)
PFTM-30-*.†	1.18 (30)	.67 (17)	—	—	.31 (8)	.39 (10)	—	.20 (5)	.08 (2)
PFTM-40-*.†	1.57 (40)	.75 (19)	—	—	.31 (8)	.39 (10)	—	.20 (5)	.14 (3.5)
PFTM-50-*.†	1.97 (50)	.79 (20)	—	—	.31 (8)	.39 (10)	—	.20 (5)	.16 (4)
PFTM-60-*.†	2.36 (60)	.90 (23)	—	—	—	.39 (10)	.59 (15)	.28 (7)	.20 (5)
PFTM-80-*.†	3.15 (80)	.98 (25)	—	—	—	.39 (10)	.59 (15)	.28 (7)	.24 (6)
PFTM-95-*.†	3.74 (95)	1.00 (25.5)	—	—	—	.39 (10)	.59 (15)	.28 (7)	.24 (6)

Inches (mm)
* Cup material
† Thread size



Dimensions

**PFTF-5A thru
PFTF-15A**

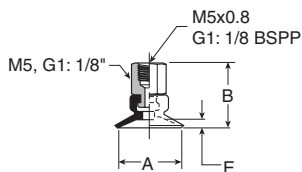

**PFTF-20B thru
PFTF-50**

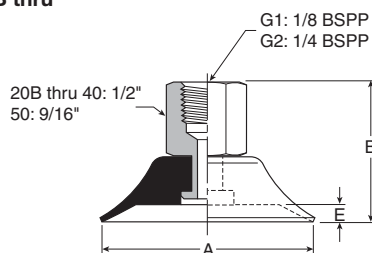

**PFTF-60 thru
PFTF-95**

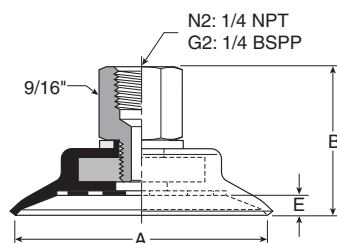

**PFTF-120 thru
PFTF-200**

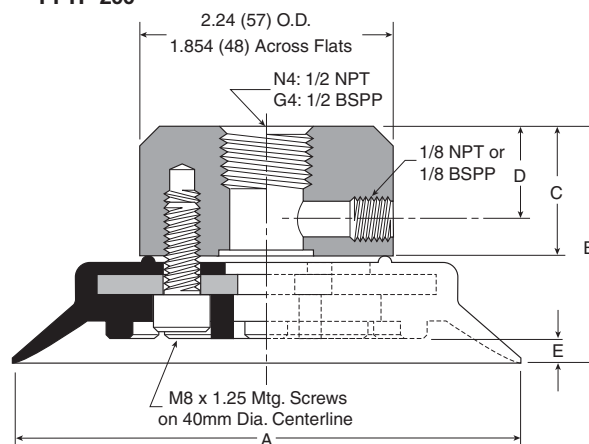

Model number	ØA	B	B (M5)	C	D	E
PFTF-5A-*†	.20 (5)	.57 (14.5)	.81 (20.5)	—	—	.03 (.8)
PFTF-6A-*†	.24 (6)	.57 (14.5)	.81 (20.5)	—	—	.03 (.8)
PFTF-8A-*†	.31 (8)	.59 (15)	.83 (21)	—	—	.05 (1.2)
PFTF-10A-*†	.39 (10)	.57 (14.5)	.81 (20.5)	—	—	.06 (1.5)
PFTF-15A-*†	.59 (15)	.63 (16)	.87 (22)	—	—	.08 (2)
PFTF-20B-*†	.79 (20)	1.04 (26.5)	—	—	—	.10 (2.5)
PFTF-30-*†	1.18 (30)	1.02 (26)	—	—	—	.08 (2)
PFTF-40-*†	1.57 (40)	1.10 (28)	—	—	—	.16 (4)
PFTF-50-*†	1.97 (50)	1.14 (29)	—	—	—	.16 (4)
PFTF-60-*†	2.36 (60)	1.40 (35.5)	—	—	—	.20 (5)
PFTF-80-*†	3.15 (80)	1.48 (37.5)	—	—	—	.24 (6)
PFTF-95-*†	3.74 (95)	1.50 (38)	—	—	—	.24 (6)
PFTF-120-*†	4.72 (120)	1.83 (46.5)	—	.94 (24)	.51 (13)	.24 (6)
PFTF-150-*†	5.91 (150)	2.11 (53.5)	—	.94 (24)	.51 (13)	.35 (9)
PFTF-200-*†	7.87 (200)	2.30 (58.5)	—	.94 (24)	.51 (13)	.51 (13)

Inches (mm)

* Cup material

† Thread size

A
Technical
PFG Flat
PBG Bellows
P5V-CFS Flat
PJG Short Bellows
PCG Multiple Bellows
PUGB Flat Swivel
Cup Fittings



- A**
- Technical
- PFG Flat
- PBG Bellows
- PVG-CFS Flat
- PJG Short Bellows
- PCG Multiple Bellows
- PUGB Flat Swivel
- Cup Fittings

Dimensions

PFTK-5A thru PFTK-10A

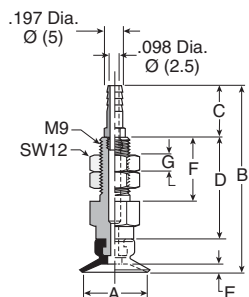

PFTK-15 thru PFTK-20

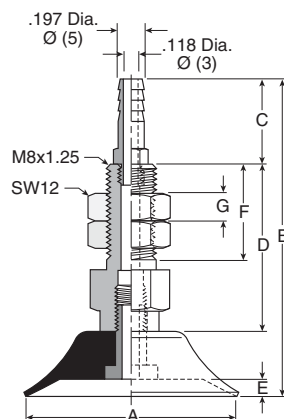

PFTK-30 thru PFTK-50

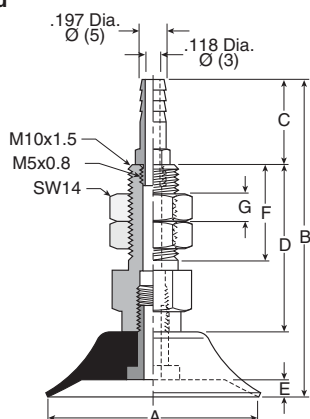

PFTK-60 thru PFTK-95

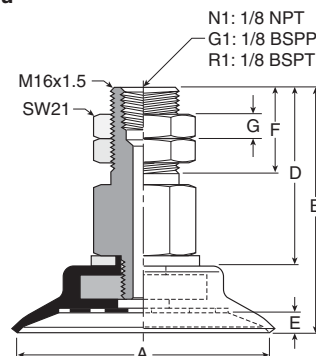

Model number	ØA	B	C	D	E	F	G	Wt oz. (g)
PFTK-5A-*	.20 (5)	1.20 (30.5)	.39 (10)	.55 (14)	.03 (.8)	.61 (15.5)	.12 (3)	.39 (11)
PFTK-6A-*	.24 (6)	1.20 (30.5)	.39 (10)	.55 (14)	.03 (.8)	.61 (15.5)	.12 (3)	.39 (11)
PFTK-8A-*	.31 (8)	1.22 (31)	.39 (10)	.55 (14)	.05 (1.2)	.61 (15.5)	.12 (3)	.39 (11)
PFTK-10A-*	.39 (10)	1.81 (46)	.63 (16)	.88 (22.5)	.06 (1.5)	.61 (15.5)	.12 (3)	.53 (15)
PFTK-15-*	.59 (15)	1.81 (46)	.63 (16)	.86 (22)	.07(1.9)	.59 (15)	.12 (3)	.71 (20)
PFTK-20-*	.79 (20)	1.89 (48)	.63 (16)	.86 (22)	.09 (2.3)	.59 (15)	.20 (5)	.71 (20)
PFTK-30-*	1.18 (30)	2.36 (60)	.63 (16)	1.26 (32)	.08 (2)	.71 (20)	.20 (5)	1.41 (40)
PFTK-40-*	1.57 (40)	2.44 (62)	.63 (16)	1.26 (32)	.14 (3.5)	.71 (20)	.20 (5)	1.41 (40)
PFTK-50-*	1.97 (50)	2.48 (63)	.63 (16)	1.26 (32)	.16 (4)	.71 (20)	.20 (5)	1.77 (50)
PFTK-60-*-†	2.36 (60)	2.30 (58.5)	—	1.67 (42.5)	.20 (5)	.79 (20)	.24 (6)	4.59 (130)
PFTK-80-*-†	3.15 (80)	2.38 (60.5)	—	1.67 (42.5)	.24 (6)	.79 (20)	.24 (6)	6.00 (170)
PFTK-95-*-†	3.74 (95)	2.40 (61)	—	1.67 (42.5)	.24 (6)	.79 (20)	.24 (6)	7.77 (220)

Inches (mm)
 * Cup material
 † Vacuum port



Dimensions

**PFYK-5A thru
 PFYK-10A**

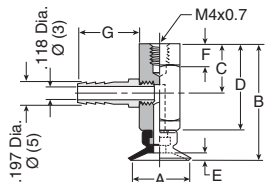

**PFYK-15 thru
 PFYK-20**

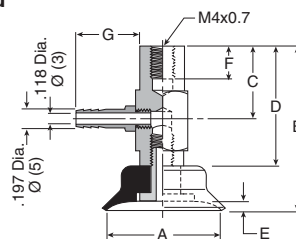

**PFYK-30 thru
 PFYK-50**

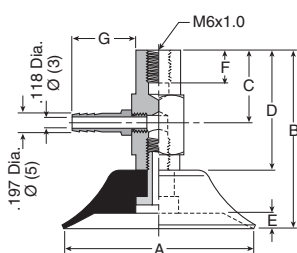

**PFYK-60 thru
 PFYK-95**

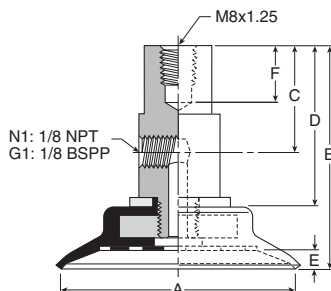

**PFYK-120 thru
 PFYK-200**

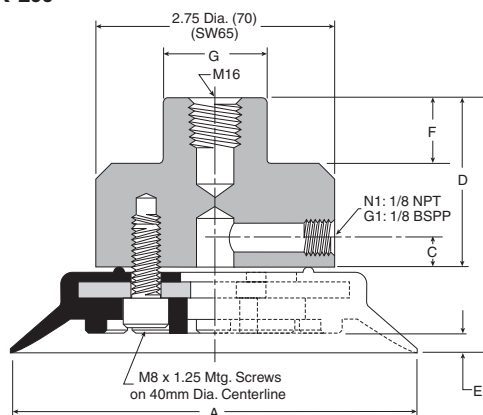

Model number	ØA	B	C	D	E	F	G	Wt oz (g)
PFYK-5A-*	.20 (5)	1.14 (29)	.51 (13)	.89 (22.5)	.03 (.8)	.24 (6)	.63 (16)	.56 (16)
PFYK-6A-*	.24 (6)	1.14 (29)	.51 (13)	.89 (22.5)	.03 (.8)	.24 (6)	.63 (16)	.56 (16)
PFYK-8A-*	.31 (8)	1.16 (29.5)	.51 (13)	.89 (22.5)	.05 (1.2)	.24 (6)	.63 (16)	.56 (16)
PFYK-10A-*	.39 (10)	1.18 (30)	.51 (13)	.89 (22.5)	.06 (1.5)	.24 (6)	.63 (16)	.56 (16)
PFYK-15-*	.59 (15)	1.18 (30)	.55 (14)	.87 (22)	.07 (1.9)	.24 (6)	.63 (16)	.71 (20)
PFYK-20-*	.79 (20)	1.26 (32)	.55 (14)	.87 (22)	.09 (2.3)	.24 (6)	.63 (16)	.71 (20)
PFYK-30-*	1.18 (30)	1.73 (44)	.79 (20)	1.26 (32)	.08 (2)	.31 (8)	.63 (16)	1.41 (40)
PFYK-40-*	1.57 (40)	1.81 (46)	.79 (20)	1.26 (32)	.14 (3.5)	.31 (8)	.63 (16)	1.77 (50)
PFYK-50-*	1.97 (50)	1.85 (47)	.79 (20)	1.26 (32)	.16 (4)	.31 (8)	.63 (16)	1.94 (55)
PFYK-60- [†]	2.36 (60)	2.30 (58.5)	1.10 (28)	1.57 (40)	.20 (5)	.43 (11)	—	4.24 (120)
PFYK-80- [†]	3.15 (80)	2.38 (60.5)	1.10 (28)	1.57 (40)	.24 (6)	.43 (11)	—	5.65 (160)
PFYK-95- [†]	3.74 (95)	2.40 (61)	1.10 (28)	1.57 (40)	.24 (6)	.43 (11)	—	7.42 (210)
PFYK-120- [†]	4.72 (120)	2.94 (75.5)	.47 (12)	1.97 (50)	.24 (6)	.79 (20)	1.18 Dia. (30)	22.6 (640)
PFYK-150- [†]	5.91 (150)	3.25 (82.5)	.47 (12)	1.97 (50)	.35 (9)	.79 (20)	1.18 Dia. (30)	32.1 (910)
PFYK-200- [†]	7.87 (200)	3.44 (87.5)	.47 (12)	1.97 (50)	.51 (13)	.79 (20)	1.18 Dia. (30)	42.4 (1200)

Inches (mm)
 * Cup material
 † Vacuum port

A
Technical
PFG Flat
PBG Bellows
P5V-CFS Flat
PJG Short Bellows
PCG Multiple Bellows
PUGB Flat Swivel
Cup Fittings



- A
- Technical
- PFG Flat
- PBG Bellows
- P5V-CFS Flat
- PUG Short Bellows
- PCG Multiple Bellows
- PUGB Flat Swivel
- Cup Fittings

Dimensions

PFTYS5A thru PFTYS15A

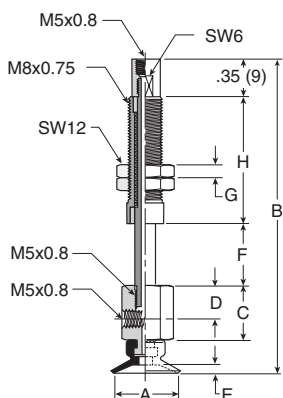

PFTYS20B thru PFTYS50

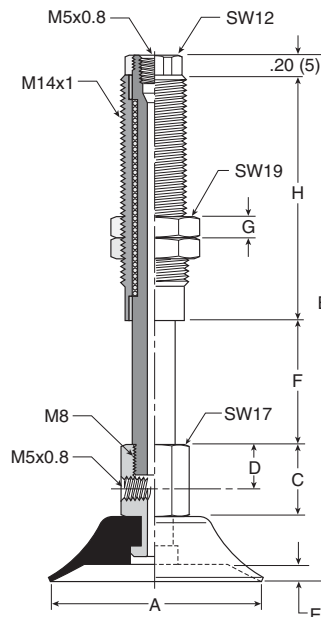

Model number	ØA	B	C	D	E	F	G	H	Wt oz (g)
PFTYS5A10*†	.20 (5)	2.42 (61.5)	.51 (13)	.31 (8)	.03 (.8)	.39 (10)	.12 (3)	.91 (23)	.65 (18.5)
PFTYS5A15*†	.20 (5)	2.91 (74)	.51 (13)	.31 (8)	.03 (.8)	.59 (15)	.12 (3)	1.20 (30.5)	.74 (21)
PFTYS6A10*†	.24 (6)	2.42 (61.5)	.51 (13)	.31 (8)	.03 (.8)	.39 (10)	.12 (3)	.91 (23)	.65 (18.5)
PFTYS6A15*†	.24 (6)	2.91 (74)	.51 (13)	.31 (8)	.03 (.8)	.59 (15)	.12 (3)	1.20 (30.5)	.74 (21)
PFTYS8A10*†	.31 (8)	2.44 (62)	.51 (13)	.31 (8)	.05 (1.2)	.39 (10)	.12 (3)	.91 (23)	.65 (18.5)
PFTYS8A15*†	.31 (8)	2.93 (74.5)	.51 (13)	.31 (8)	.05 (1.2)	.59 (15)	.12 (3)	1.20 (30.5)	.74 (21)
PFTYS10A10*†	.39 (10)	2.48 (63)	.51 (13)	.31 (8)	.06 (1.5)	.39 (10)	.12 (3)	.91 (23)	.65 (18.5)
PFTYS10A15*†	.39 (10)	2.95 (75)	.51 (13)	.31 (8)	.06 (1.5)	.59 (15)	.12 (3)	1.20 (30.5)	.74 (21)
PFTYS15A10*†	.59 (15)	2.50 (63.5)	.51 (13)	.31 (8)	.08 (2)	.39 (10)	.12 (3)	.91 (23)	.65 (18.5)
PFTYS15A15*†	.59 (15)	2.97 (75.5)	.51 (13)	.31 (8)	.08 (2)	.59 (15)	.12 (3)	1.20 (30.5)	.74 (21)
PFTYS20B15*†	.79 (20)	3.37 (85.5)	.67 (17)	.39 (10)	.09 (2.3)	.59 (15)	.20 (5)	1.42 (36)	2.5 (71)
PFTYS20B30*†	.79 (20)	4.82 (122.5)	.67 (17)	.39 (10)	.09 (2.3)	1.18 (30)	.20 (5)	2.28 (58)	3.4 (96)
PFTYS3015*†	1.18 (30)	3.35 (85)	.67 (17)	.39 (10)	.08 (2)	.59 (15)	.20 (5)	1.42 (36)	2.5 (72)
PFTYS3030*†	1.18 (30)	4.80 (122)	.67 (17)	.39 (10)	.08 (2)	1.18 (30)	.20 (5)	2.28 (58)	3.5 (97)
PFTYS4015*†	1.57 (40)	3.43 (87)	.67 (17)	.39 (10)	.14 (3.5)	.59 (15)	.20 (5)	1.42 (36)	2.7 (76)
PFTYS4030*†	1.57 (40)	4.88 (124)	.67 (17)	.39 (10)	.14 (3.5)	1.18 (30)	.20 (5)	2.28 (58)	3.6 (101)
PFTYS5015*†	1.97 (50)	3.46 (88)	.67 (17)	.39 (10)	.16 (4)	.59 (15)	.20 (5)	1.42 (36)	3.0 (85)
PFTYS5030*†	1.97 (50)	4.92 (125)	.67 (17)	.39 (10)	.16 (4)	1.18 (30)	.20 (5)	2.28 (58)	3.9 (110)

Inches (mm)
 * Cup material
 † Vacuum port



Dimensions

**PFTYS60 thru
PFTYS95**

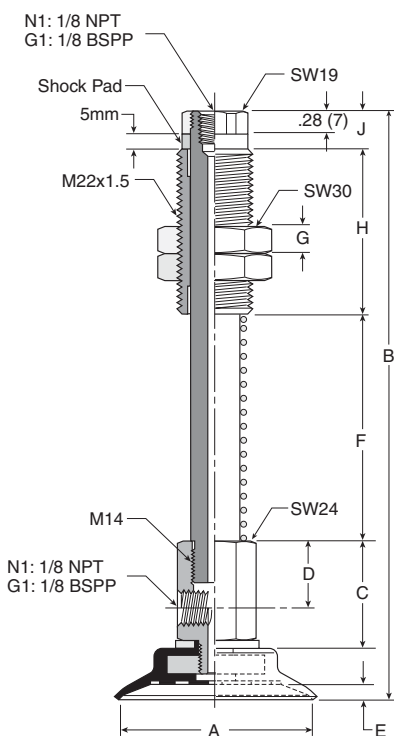

**PFTYS120 thru
PFTYS200**

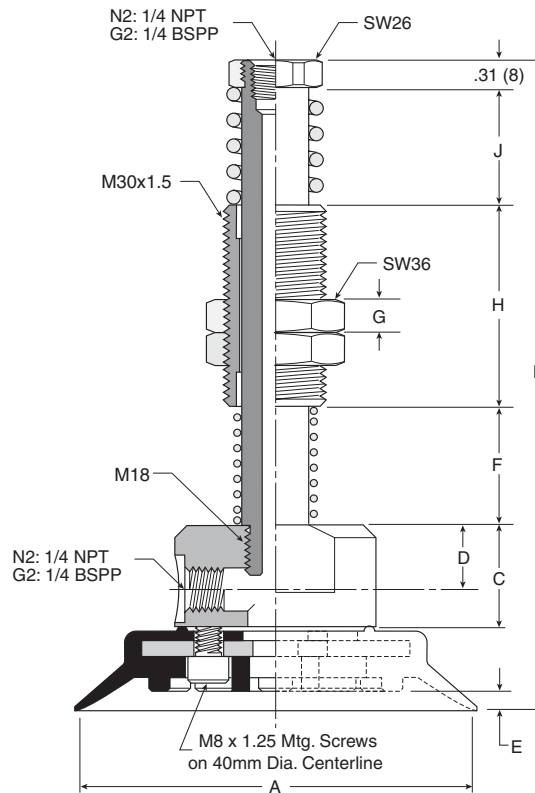

A

Technical

PFG

Flat

PBG

Bellows

P5V-CFS

Flat

PJG Short

Bellows

PCG

Multiple

Bellows

PUGB

Flat Swivel

Cup

Fittings

Model number	ØA	B	C	D	E	F	G	H	J	Wt oz (g)
PFTYS6030*†	2.36 (60)	6.02 (153)	1.28 (32.5)	.78 (20)	.20 (5)	1.77 (45)	.39 (10)	1.97 (50)	.47 (12)	9.7 (282)
PFTYS6050*†	2.36 (60)	7.01 (178)	1.28 (32.5)	.78 (20)	.20 (5)	2.76 (70)	.39 (10)	1.97 (50)	.47 (12)	11.2 (316)
PFTYS8030*†	3.15 (80)	6.10 (155)	1.28 (32.5)	.78 (20)	.24 (6)	1.77 (45)	.39 (10)	1.97 (50)	.47 (12)	11 (310)
PFTYS8050*†	3.15 (80)	7.09 (180)	1.28 (32.5)	.78 (20)	.24 (6)	2.76 (70)	.39 (10)	1.97 (50)	.47 (12)	12.2 (344)
PFTYS9530*†	3.74 (95)	6.12 (156)	1.28 (32.5)	.78 (20)	.24 (6)	1.77 (45)	.39 (10)	1.97 (50)	.47 (12)	12.4 (350)
PFTYS9550*†	3.74 (95)	7.11 (181)	1.28 (32.5)	.78 (20)	.24 (6)	2.76 (70)	.39 (10)	1.97 (50)	.47 (12)	13.6 (384)
PFTYS12020*†	4.72 (120)	7.56 (192)	1.28 (32.5)	.71 (18)	.24 (6)	1.38 (35)	.39 (10)	2.36 (60)	1.38 (35)	41.2 (1165)
PFTYS12070*†	4.72 (120)	10.12 (257)	1.28 (32.5)	.71 (18)	.24 (6)	3.94 (100)	.39 (10)	2.36 (60)	1.38 (35)	44 (1246)
PFTYS15020*†	5.91 (150)	7.83 (199)	1.28 (32.5)	.71 (18)	.35 (9)	1.38 (35)	.39 (10)	2.36 (60)	1.38 (35)	49 (1389)
PFTYS15070*†	5.91 (150)	10.39 (264)	1.28 (32.5)	.71 (18)	.35 (9)	3.94 (100)	.39 (10)	2.36 (60)	1.38 (35)	52 (1471)
PFTYS20020*†	7.87 (200)	8.03 (204)	1.28 (32.5)	.71 (18)	.51 (13)	1.38 (35)	.39 (10)	2.36 (60)	1.38 (35)	62 (1755)
PFTYS20070*†	7.87 (200)	10.59 (269)	1.28 (32.5)	.71 (18)	.51 (13)	3.94 (100)	.39 (10)	2.36 (60)	1.38 (35)	64.9 (1836)

Inches (mm)
* Cup material
† Vacuum port



Features

A

These cups are for curved, corrugated, lightly textured surfaces and flexible product. Under vacuum, the bellow cup will collapse on contact and lift the product for a short distance. This inherent performance facilitates lifting and destack operations by breaking the vacuum between stacked product. The bellow style adds level compensation for applications that have inconsistent stack heights or uneven surfaces. The inclusive 30-degree rotation of the bellow helps maintain the vacuum seal when lifting sheet products that flex. Because of it's shape however the bellows suction cup is not very well suitable for applications involving lifting vertical surfaces.

Technical

PFG Flat

PBG Bellows

P5V-CFS Flat

PJG Short Bellows

PCG Multiple Bellows

PUGB Flat Swivel

Cup Fittings



Features

- Bellows design for level compensation within restricted clearances
- Sheet separation for flexible and stacked products
- Soft seal lip for flexible products
- 10mm to 150mm diameters

Styles

- PBTM series male thread connector
- PBTf series female thread connector
- PBTk series barbed bulkhead
- PBYK series 90° barbed adapter
- PBTYS series bulkhead level compensator

Specifications

Cup material	Nitrile	Silicon	Urethane
Material code	NBR	SI	U
Operating temperature (°C)	-20° to +120°	-60° to +250°	-20° to +75°
Color	Black	White	Blue
Hardness, shore A (°Sh)	55 ±5	55 ±5	55 ±5

How to order

Cups assemblies and replacement cups are specified by cup diameter and material. Standard nitrile and silicon are listed on the following pages. To specify an alternative material, replace the cup material with alternative cup material code.

Example: To specify a cup assembly with urethane (U), replace (NBR) with (U) in the part number. PBTM-20B-NBR-G1 becomes PBTM-20B-U-G1. Inquire with factory for availability.

Application guide

Bellows



Flat surface, thin section	Flat surface, any section	Slightly bowed surface, thin section	Slightly bowed surface, any section	Bowed surface, thin section	Bowed surface, any section	Soft porous material, any section	Differences in heights and levels	Corrugated sheet handling	Not for vertical lift	Metal sheet handling
----------------------------	---------------------------	--------------------------------------	-------------------------------------	-----------------------------	----------------------------	-----------------------------------	-----------------------------------	---------------------------	-----------------------	----------------------



Ordering Information

PBTM Series Male Thread Connector

Simple male connection for low profile positions secured to a plate or bracket. NPT, G, metric threads.
Fitting material: aluminum.

Installation

Note:
When installing cup assemblies, use a sealant material to secure the assembly and prevent vacuum leakage.

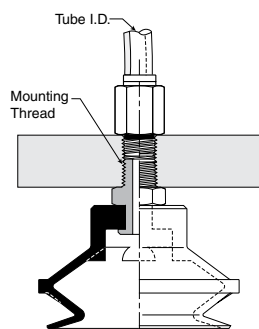

Cup diameter (mm)	Vacuum port	Complete assembly Nitrile (NBR)	Replacement cup Nitrile (NBR)	Complete assembly Silicon (SI)	Replacement cup Silicon (SI)	Replacement cup fitting
10	M5	PBTM-10A-NBR-M5	PBG-10A-NBR	PBTM-10A-SI-M5	PBG-10A-SI	FTM-5A-M5H
10	1/8 BSPP	PBTM-10A-NBR-G1	PBG-10A-NBR	PBTM-10A-SI-G1	PBG-10A-SI	FTM-5A-G1
15	M5	PBTM-15A-NBR-M5	PBG-15A-NBR	PBTM-15A-SI-M5	PBG-15A-SI	FTM-5A-M5H
15	1/8 BSPP	PBTM-15A-NBR-G1	PBG-15A-NBR	PBTM-15A-SI-G1	PBG-15A-SI	FTM-5A-G1
20	1/8 BSPP	PBTM-20B-NBR-G1	PBG-20B-NBR	PBTM-20B-SI-G1	PBG-20B-SI	FTM-20B-G1H
20	1/4 BSPP	PBTM-20B-NBR-G2	PBG-20B-NBR	PBTM-20B-SI-G2	PBG-20B-SI	FTM-20B-G2
20	M10	PBTM-20B-NBR-M10	PBG-20B-NBR	PBTM-20B-SI-M10	PBG-20B-SI	FTM-20B-M10
20	1/8 NPT	PBTM-20B-NBR-N1	PBG-20B-NBR	PBTM-20B-SI-N1	PBG-20B-SI	FTM-20B-N1
30	1/8 BSPP	PBTM-30-NBR-G1	PBG-30-NBR	PBTM-30-SI-G1	PBG-30-SI	FTM-20B-G1H
30	1/4 BSPP	PBTM-30-NBR-G2	PBG-30-NBR	PBTM-30-SI-G2	PBG-30-SI	FTM-20B-G2
30	M10	PBTM-30-NBR-M10	PBG-30-NBR	PBTM-30-SI-M10	PBG-30-SI	FTM-20B-M10
30	1/8 NPT	PBTM-30-NBR-N1	PBG-30-NBR	PBTM-30-SI-N1	PBG-30-SI	FTM-20B-N1
40	1/8 BSPP	PBTM-40-NBR-G1	PBG-40-NBR	PBTM-40-SI-G1	PBG-40-SI	FTM-20B-G1H
40	1/4 BSPP	PBTM-40-NBR-G2	PBG-40-NBR	PBTM-40-SI-G2	PBG-40-SI	FTM-20B-G2
40	M10	PBTM-40-NBR-M10	PBG-40-NBR	PBTM-40-SI-M10	PBG-40-SI	FTM-20B-M10
40	1/8 NPT	PBTM-40-NBR-N1	PBG-40-NBR	PBTM-40-SI-N1	PBG-40-SI	FTM-20B-N1
50	1/8 BSPP	PBTM-50-NBR-G1	PBG-50-NBR	PBTM-50-SI-G1	PBG-50-SI	FTM-50-G1H
50	1/4 BSPP	PBTM-50-NBR-G2	PBG-50-NBR	PBTM-50-SI-G2	PBG-50-SI	FTM-50-G2
50	1/8 NPT	PBTM-50-NBR-N1	PBG-50-NBR	PBTM-50-SI-N1	PBG-50-SI	FTM-50-N1
75	1/4 BSPP	PBTM-75-NBR-G2	PBG-75-NBR	PBTM-75-SI-G2	PBG-75-SI	FTM-60-G2
75	M10	PBTM-75-NBR-M10	PBG-75-NBR	PBTM-75-SI-M10	PBG-75-SI	FTM-60-M10
75	1/4 NPT	PBTM-75-NBR-N2	PBG-75-NBR	PBTM-75-SI-N2	PBG-75-SI	FTM-60-N2

☐ Most popular.



A
Technical
PBG Flat
PBG Bellows
P5V-CFS Flat
PJG Short Bellows
PCG Multiple Bellows
PUGB Flat Swivel
Cup Fittings

Ordering Information
A
PBTF Series Female Thread Connector

Simple female connection for low profile positions secured to a plate or bracket. NPSF, G threads. Fitting material: aluminum.

Installation
Note:

When installing cup assemblies, use a sealant material to secure the assembly and prevent vacuum leakage.

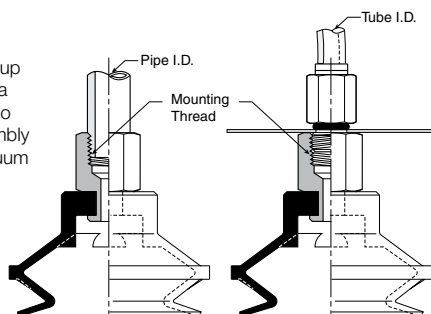

Cup diameter (mm)	Vacuum port	Complete assembly Nitrile (NBR)	Replacement cup Nitrile (NBR)	Complete assembly Silicon (SI)	Replacement cup Silicon (SI)	Replacement cup fitting
10	1/8 BSPP	PBTF-10A-NBR-G1	PBG-10A-NBR	PBTF-10A-SI-G1	PBG-10A-SI	FTF-5A-G1
10	M5	PBTF-10A-NBR-M5	PBG-10A-NBR	PBTF-10A-SI-M5	PBG-10A-SI	FTF-5A-M5
15	1/8 BSPP	PBTF-15A-NBR-G1	PBG-15A-NBR	PBTF-15A-SI-G1	PBG-15A-SI	FTF-5A-G1
15	M5	PBTF-15A-NBR-M5	PBG-15A-NBR	PBTF-15A-SI-M5	PBG-15A-SI	FTF-5A-M5
20	1/8 BSPP	PBTF-20B-NBR-G1	PBG-20B-NBR	PBTF-20B-SI-G1	PBG-20B-SI	FTF-20B-G1
30	1/8 BSPP	PBTF-30-NBR-G1	PBG-30-NBR	PBTF-30-SI-G1	PBG-30-SI	FTF-20B-G1
30	1/4 BSPP	PBTF-30-NBR-G2	PBG-30-NBR	PBTF-30-SI-G2	PBG-30-SI	FTF-20B-G2
40	1/8 BSPP	PBTF-40-NBR-G1	PBG-40-NBR	PBTF-40-SI-G1	PBG-40-SI	FTF-20B-G1
40	1/4 BSPP	PBTF-40-NBR-G2	PBG-40-NBR	PBTF-40-SI-G2	PBG-40-SI	FTF-20B-G2
50	1/8 BSPP	PBTF-50-NBR-G1	PBG-50-NBR	PBTF-50-SI-G1	PBG-50-SI	FTF-50-G1
50	1/4 BSPP	PBTF-50-NBR-G2	PBG-50-NBR	PBTF-50-SI-G2	PBG-50-SI	FTF-50-G2
75	1/4 BSPP	PBTF-75-NBR-G2	PBG-75-NBR	PBTF-75-SI-G2	PBG-75-SI	FTF-60-G2
75	1/4 NPT	PBTF-75-NBR-N2	PBG-75-NBR	PBTF-75-SI-N2	PBG-75-SI	FTF-60-N2
110	1/2 BSPP	PBTF-110-NBR-G4	PBG-110-NBR	PBTF-110-SI-G4	PBG-110-SI	FTF-120-G4
110	1/2 NPT	PBTF-110-NBR-N4	PBG-110-NBR	PBTF-110-SI-N4	PBG-110-SI	FTF-120-N4
150	1/2 BSPP	PBTF-150-NBR-G4	PBG-150-NBR	PBTF-150-SI-G4	PBG-150-SI	FTF-120-G4
150	1/2 NPT	PBTF-150-NBR-N4	PBG-150-NBR	PBTF-150-SI-N4	PBG-150-SI	FTF-120-N4

 Most popular.



PBTK Series Barbed Bulkhead

Top stem connectors secured with jam nuts and allow tubing connections at the top side. Fitting materials: nickel plated brass.

Installation

Note:

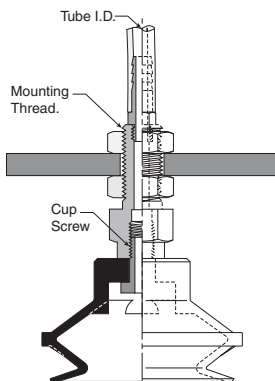
When installing cup assemblies, use a sealant material to secure the assembly and prevent vacuum leakage.



Cup diameter (mm)	Vacuum port	Complete assembly Nitrile (NBR)	Replacement cup Nitrile (NBR)	Complete assembly Silicon (SI)	Replacement cup Silicon (SI)	Replacement cup fitting
10	Barb	PBTK-10A-NBR	PBG-10A-NBR	PBTK-10A-SI	PBG-10A-SI	FTK-5A
15	Barb	PBTK-15A-NBR	PBG-15A-NBR	PBTK-15A-SI	PBG-15-SI	FTK-5A
20	Barb	PBTK-20-NBR	PBG-20-NBR	PBTK-20-SI	PBG-20-SI	FTK-20
30	Barb	PBTK-30-NBR	PBG-30-NBR	PBTK-30-SI	PBG-30-SI	FTK-25
40	Barb	PBTK-40-NBR	PBG-40-NBR	PBTK-40-SI	PBG-40-SI	FTK-25
50	Barb	PBTK-50-NBR	PBG-50-NBR	PBTK-50-SI	PBG-50-SI	FTK-50
75	1/8 BSPP	PBTK-75-NBR-G1	PBG-75-NBR	PBTK-75-SI-G1	PBG-75-SI	FTK-60-G1
75	1/8 NPT	PBTK-75-NBR-N1	PBG-75-NBR	PBTK-75-SI-N1	PBG-75-SI	FTK-60-N1

Most popular.



A
Technical
PBG Flat
PBG Bellows
P5V-CFS Flat
PJG Short Bellows
PCG Multiple Bellows
PIUGB Flat Swivel
Cup Fittings

A
PBYK Series 90° Barbed Adapter

Side stem connectors allow you to secure the stem with a bolt through a plate or "L" bracket to allow the tube connection from the side port. Fitting material: nickel plated brass.

Installation
Note:

When installing cup assemblies, use a sealant material to secure the assembly and prevent vacuum leakage.

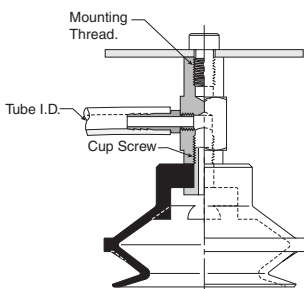

Cup diameter (mm)	Vacuum port	Complete assembly Nitrile (NBR)	Replacement cup Nitrile (NBR)	Complete assembly Silicon (SI)	Replacement cup Silicon (SI)	Replacement cup fitting
10	Barb	PBYK-10A-NBR	PBG-10A-NBR	PBYK-10A-SI	PBG-10A-SI	FYK-5A
15	Barb	PBYK-15A-NBR	PBG-15A-NBR	PBYK-15A-SI	PBG-15A-SI	FYK-15
20	Barb	PBYK-20-NBR	PBG-20-NBR	PBYK-20-SI	PBG-20-SI	FYK-20
30	Barb	PBYK-30-NBR	PBG-30-NBR	PBYK-30-SI	PBG-30-SI	FYK-25
40	Barb	PBYK-40-NBR	PBG-40-NBR	PBYK-40-SI	PBG-40-SI	FYK-25
50	Barb	PBYK-50-NBR	PBG-50-NBR	PBYK-50-SI	PBG-50-SI	FYK-50
75	1/8 BSPP	PBYK-75-NBR-G1	PBG-75-NBR	PBYK-75-SI-G1	PBG-75-SI	FYK-60-G1
75	1/8 NPT	PBYK-75-NBR-N1	PBG-75-NBR	PBYK-75-SI-N1	PBG-75-SI	FYK-60-N1
110	1/8 BSPP	PBYK-110-NBR-G1	PBG-110-NBR	PBYK-110-SI-G1	PBG-110-SI	FYK-120-G1
110	1/8 NPT	PBYK-110-NBR-N1	PBG-110-NBR	PBYK-110-SI-N1	PBG-110-SI	FYK-120-N1
150	1/8 BSPP	PBYK-150-NBR-G1	PBG-150-NBR	PBYK-150-SI-G1	PBG-150-SI	FYK-120-G1
150	1/8 NPT	PBYK-150-NBR-N1	PBG-150-NBR	PBYK-150-SI-N1	PBG-150-SI	FYK-120-N1

Most popular.



PBTYS Series Bulkhead Level Compensator

303 stainless steel construction secured with jam nuts. Spring biased compensators can absorb impacts of down-strokes and adjust for different levels of pick up points. 303 stainless corrosion resistant materials with drymet bushings increases the strength and life.

Installation

Note:

When installing cup assemblies, use a sealant material to secure the assembly and prevent vacuum leakage. Shown are interchangeable connectors & plugs for port connections.

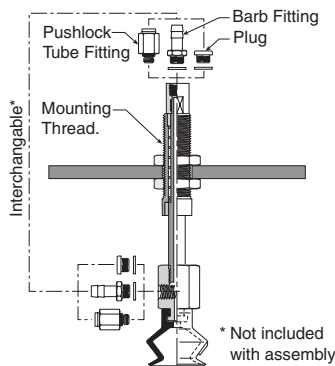

Cup dia. (mm)	Vacuum port	Stroke (mm)	Spring compression Force lbf (N)		Cup material Nitrile assembly (NBR)	Replacement cup Nitrile (NBR)	Cup material Silicon assembly (SI)	Replacement cup Silicon (SI)	Level Compensator P/N
			0%	100%					
10	M5	10	.11 (.49)	.13 (.59)	PBTYS10A10NBRM5	PBG-10A-NBR	PBTYS10A10SIM5	PBG-10A-SI	TYS-5A-10
10	M5	15	.11 (.49)	.13 (.59)	PBTYS10A15NBRM5	PBG-10A-NBR	PBTYS10A15SIM5	PBG-10A-SI	TYS-5A-15
15	M5	10	.11 (.49)	.13 (.59)	PBTYS15A10NBRM5	PBG-15A-NBR	PBTYS15A10SIM5	PBG-15A-SI	TYS-5A-10
15	M5	15	.11 (.49)	.13 (.59)	PBTYS15A15NBRM5	PBG-15A-NBR	PBTYS15A15SIM5	PBG-15A-SI	TYS-5A-15
20	M5	15	.56 (2.5)	.79 (3.4)	PBTYS20B15NBRM5	PBG-20B-NBR	PBTYS20B15SIM5	PBG-20B-SI	TYS-20B-15
20	M5	30	.56 (2.5)	1.2 (4.9)	PBTYS20B30NBRM5	PBG-20B-NBR	PBTYS20B30SIM5	PBG-20B-SI	TYS-20B-30
30	M5	15	.56 (2.5)	.79 (3.4)	PBTYS3015NBRM5	PBG-30-NBR	PBTYS3015SIM5	PBG-30-SI	TYS-20B-15
30	M5	30	.56 (2.5)	1.2 (4.9)	PBTYS3030NBRM5	PBG-30-NBR	PBTYS3030SIM5	PBG-30-SI	TYS-20B-30
40	M5	15	.56 (2.5)	.79 (3.4)	PBTYS4015NBRM5	PBG-40-NBR	PBTYS4015SIM5	PBG-40-SI	TYS-20B-15
40	M5	30	.56 (2.5)	1.2 (4.9)	PBTYS4030NBRM5	PBG-40-NBR	PBTYS4030SIM5	PBG-40-SI	TYS-20B-30
50	M5	15	.56 (2.5)	1.2 (4.9)	PBTYS5015NBRM5	PBG-50-NBR	PBTYS5015SIM5	PBG-50-SI	TYS-50-15
50	M5	30	.67 (2.9)	1.4 (5.9)	PBTYS5030NBRM5	PBG-50-NBR	PBTYS5030SIM5	PBG-50-SI	TYS-50-30
75	1/8 NPT	30	1.6 (6.8)	3.6 (15.6)	PBTYS7530NBRN1	PBG-75-NBR	PBTYS7530SIN1	PBG-75-SI	TYS-60-30
75	1/8 NPT	50	1.9 (8.3)	4.5 (19.6)	PBTYS7550NBRN1	PBG-75-NBR	PBTYS7550SIN1	PBG-75-SI	TYS-60-50
110	1/4 NPT	20	3.6 (15.6)	6.8 (29)	PBTYS12020NBRN2	PBG-110-NBR	PBTYS11020SIN2	PBG-110-SI	TYS-120-20
110	1/4 NPT	70	3.4 (14.7)	6.8 (29)	PBTYS12070NBRN2	PBG-110-NBR	PBTYS11070SIN2	PBG-110-SI	TYS-120-70
150	1/4 NPT	20	3.6 (15.6)	6.8 (29)	PBTYS15020NBRN2	PBG-150-NBR	PBTYS15020SIN2	PBG-150-SI	TYS-120-20
150	1/4 NPT	70	3.4 (14.7)	6.8 (29)	PBTYS15070NBRN2	PBG-150-NBR	PBTYS15070SIN2	PBG-150-SI	TYS-120-70

☐ Most popular.



A
Technical
PBG Flat
PBG Bellows
P5V-CFS Flat
PJG Short Bellows
PCG Multiple Bellows
PUGB Flat Swivel
Cup Fittings

A
Applications

- Round objects

- Uneven surfaces
- Curved product
- Level compensation

- Flexible product
- Soft seal lip

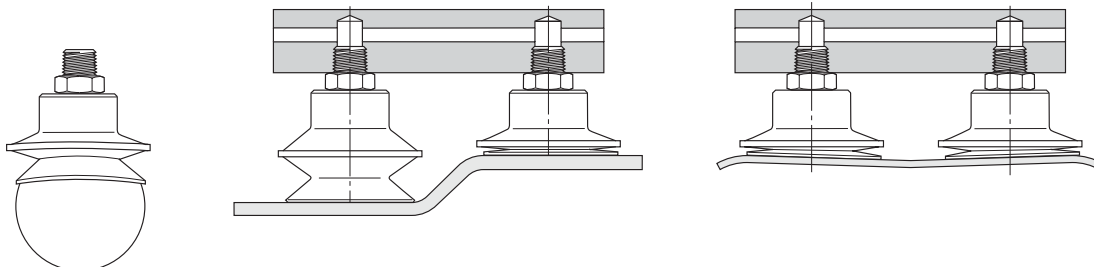
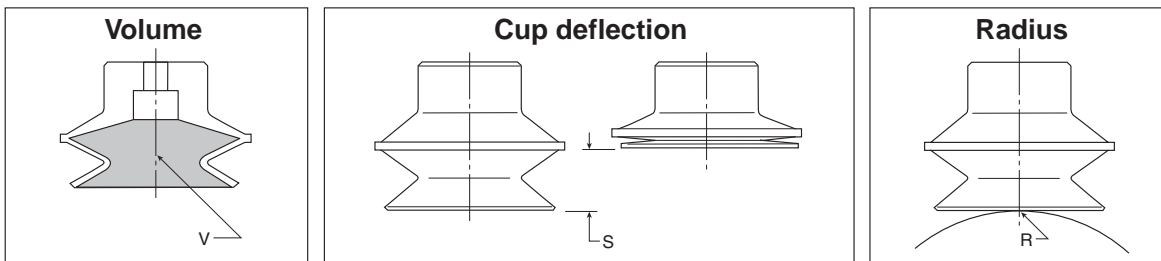
Main data for bellows PBG cups

Model number	Cup diameter inches (mm)	Area cm ²	Volume (V) liters	Lifting force @60% (N)		Cup deflection (S) (mm)	Radius (R) (mm)
PBG-10A-*	.39 (10)	0.79	.0002	4.80	—	.16 (4)	4
PBG-15A-*	.59 (15)	1.77	.0007	10.80	—	.24 (6)	6
PBG-20-*	.79 (20)	3.14	.001	19.20	—	.35 (9)	8
PBG-20B-*	.79 (20)	3.14	.001	19.20	—	.35 (9)	8
PBG-30-*	1.18 (30)	7.07	.004	43.2	—	.51 (13)	15
PBG-40-*	1.57 (40)	12.60	.009	76.9	—	.51 (13)	30
PBG-50-*	1.97 (50)	19.60	.026	120	—	.79 (20)	40
PBG-75-*	2.95 (75)	44.02	.076	270	—	.87 (22)	70
PBG-110-*	4.33 (110)	95.00	.111	434	—	1.14 (29)	100
PBG-150-*	5.91 (150)	176.70	.260	1081	—	1.50 (38)	130

* Cup material

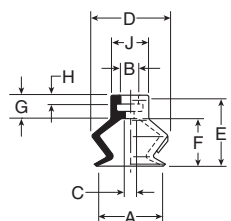
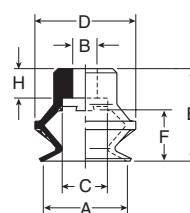
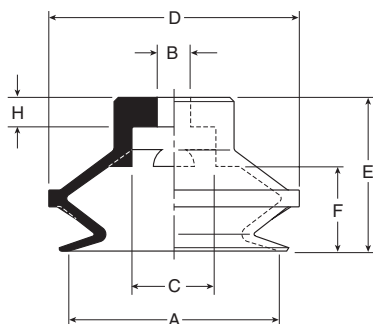
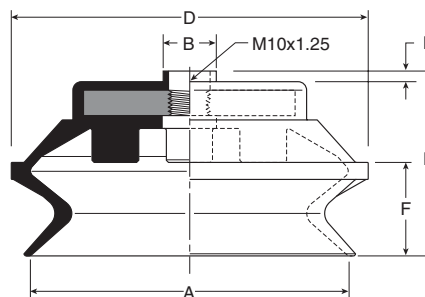
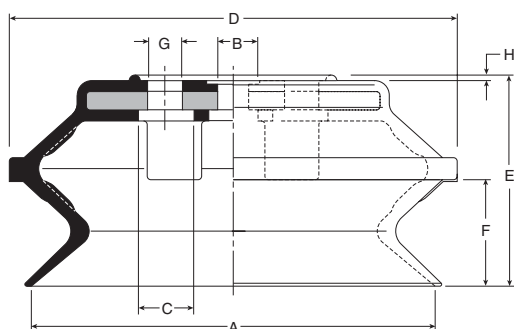
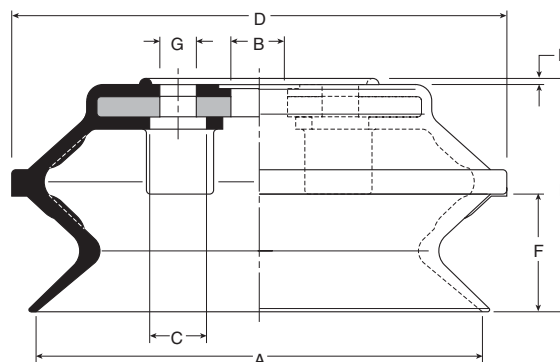
PBG Series Replacement Cup Dimensions
**PBG-10A and
PBG-20B**

**PBG-20 thru
PBG-40**

PBG-50

PBG-75

PBG-110

PBG-150

Model number	ØA	ØB	ØC	ØD	E	F	G	H	ØJ
PBG-10A-*	.42 (10.6)	.16 (4)	.08 (2)	.49 (12.4)	.53 (13.5)	.30 (7.5)	.24 (6)	.08 (2)	.24 (6)
PBG-15A-*	.59 (15)	.16 (4)	.16 (4)	.67 (17)	.63 (16)	.39 (10)	.24 (6)	.08 (2)	.24 (6)
PBG-20B-*	.79 (20)	.24 (6)	.43 (10.8)	.94 (24)	.87 (22)	.47 (12)	—	.28 (7)	—
PBG-20-*	.79 (20)	.18 (4.6)	.43 (10.8)	.94 (24)	.77 (19.5)	.47 (12)	—	.18 (4.5)	—
PBG-30-*	1.18 (30)	.23 (5.8)	.43 (10.8)	1.42 (36)	1.20 (30.5)	.67 (17)	—	.28 (7)	—
PBG-40-*	1.57 (40)	.23 (5.8)	.43 (10.8)	1.81 (46)	1.20 (30.5)	.61 (15.5)	—	.28 (7)	—
PBG-50-*	1.97 (50)	.31 (7.8)	.78 (19.8)	2.34 (59.5)	1.44 (36.5)	.79 (20)	—	.28 (7)	—
PBG-75-*	2.95 (75)	.49 (12.5)	—	3.31 (84)	1.71 (43.5)	.87 (22)	—	.10 (2.5)	—
PBG-110-*	4.33 (110)	.55 (14)	.55 (14)	4.80 (122)	2.26 (57.5)	1.14 (29)	—	.059 (1.5)	—
PBG-150-*	5.91 (150)	.79 (20)	.55 (14)	6.57 (167)	3.01 (76.5)	1.50 (38)	4xØ9xØ40	.059 (1.5)	—

Inches (mm)

* Cup material

A

Technical

PBG Flat

PBG Bellows

P5V-CFS Flat

P.JG Short Bellows

PCG Multiple Bellows

PUGB Flat Swivel

Cup Fittings



- A
- Technical
- PFG Flat
- PBG Bellows
- P5V-CFS Flat
- PUG Short Bellows
- PCG Multiple Bellows
- PUGB Flat Swivel
- Cup Fittings

Dimensions

PBTM-10A thru PBTM-15

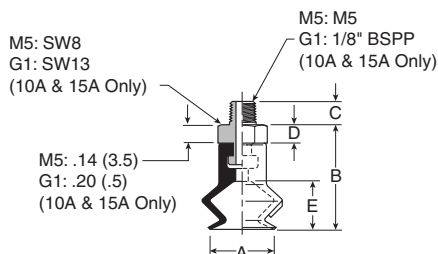

PBTM-20B thru PBTM-50

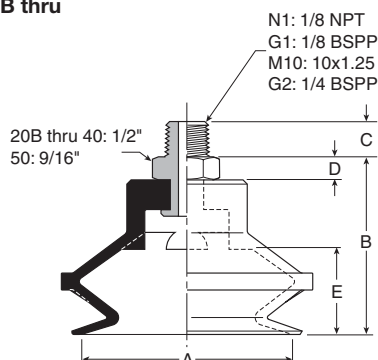

PBTM-75

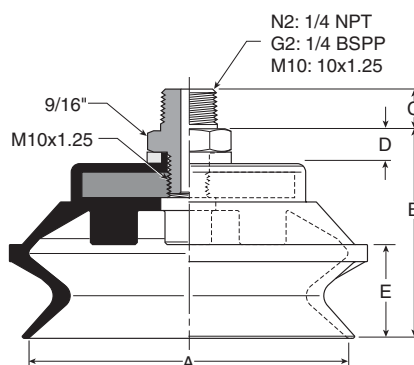

Model number	ØA	B	C (M5)	C (N1 / G1)	C (M10 / G2)	C (N2)	D	E
PBTM-10A- [*] †	.39 (10)	.67 (17)	.18 (4.5)	.31 (8)	—	—	See Dwg.	.30 (7.5)
PBTM-15A- [*] †	.59 (15)	.77 (19.5)	.18 (4.5)	.31 (8)	—	—	See Dwg.	.39 (10)
PBTM-20B- [*] †	.79 (20)	1.06 (27)	—	.31 (8)	.39 (10)	—	.20 (5)	.47 (12)
PBTM-30- [*] †	1.18 (30)	1.40 (35.5)	—	.31 (8)	.39 (10)	—	.20 (5)	.67 (17)
PBTM-40- [*] †	1.57 (40)	1.40 (35.5)	—	.31 (8)	.39 (10)	—	.20 (5)	.61 (15.5)
PBTM-50- [*] †	1.97 (50)	1.63 (41.5)	—	.31 (8)	.39 (10)	—	.20 (5)	.79 (20)
PBTM-75- [*] †	3.74 (95)	1.99 (50.5)	—	—	.39 (10)	.59 (15)	.28 (7)	.87 (22)

Inches (mm)
^{*} Cup material
[†] Thread size



Dimensions

**PBTF-10A thru
 PBTF-15A**

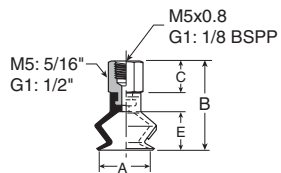

**PBTF-20B thru
 PBTF 50**

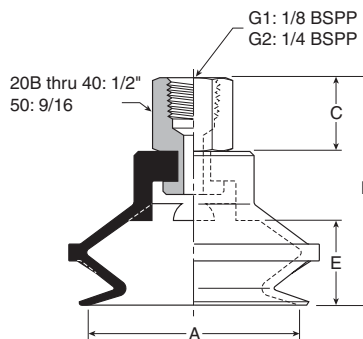

PBTF-75

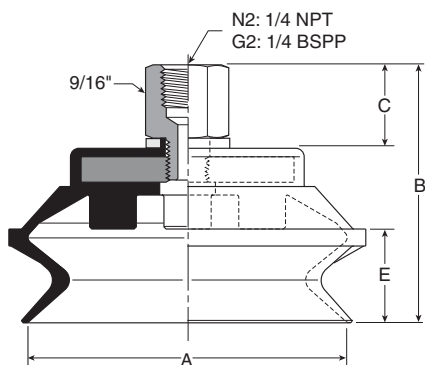

**PBTF-110 thru
 PBTF-150**

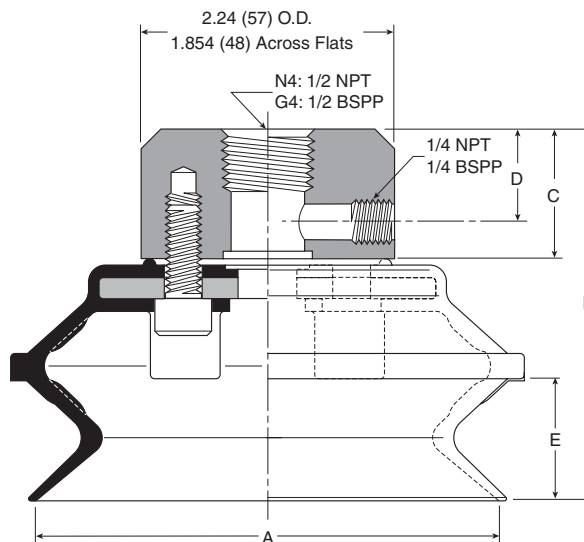

Model number	ØA	B	B (M5)	C	C (M5)	D	E
PBTF-10A-*†	.39 (10)	.85 (21.5)	1.08 (27.5)	.31 (8)	.55 (14)	—	.30 (7.5)
PBTF-15A-*†	.59 (15)	.94 (24)	1.18 (30)	.31 (8)	.55 (14)	—	.39 (10)
PBTF-20B-*†	.79 (20)	1.42 (36)	—	.55 (14)	—	—	.47 (12)
PBTF-30-*†	1.18 (30)	1.75 (44.5)	—	.55 (14)	—	—	.70 (17)
PBTF-40-*†	1.57 (40)	1.75 (44.5)	—	.55 (14)	—	—	.61 (15.5)
PBTF-50-*†	1.97 (50)	1.99 (50.5)	—	.55 (14)	—	—	.79 (20)
PBTF-75-*†	3.74 (95)	2.38 (60.5)	—	.77 (19.5)	—	—	.87 (22)
PBTF-110-*†	4.72 (120)	3.07 (78)	—	.94 (24)	—	.51 (13)	1.14 (29)
PBTF-150-*†	5.91 (150)	3.82 (97)	—	.94 (24)	—	.51 (13)	1.50 (38)

Inches (mm)
 * Cup material
 † Thread size

A
Technical
PFG Flat
PBG Bellows
P5V-CFS Flat
PJG Short Bellows
PCG Multiple Bellows
PUGB Flat Swivel
Cup Fittings



- A
- Technical
- PFG Flat
- PBG Bellows
- P5V-CFS Flat
- PUG Short Bellows
- PCG Multiple Bellows
- PUGB Flat Swivel
- Cup Fittings

Dimensions

**PBTK-10A thru
 PBTK-15A**

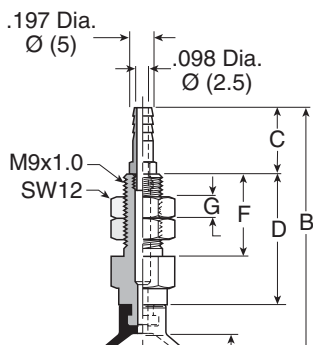

PBTK-20

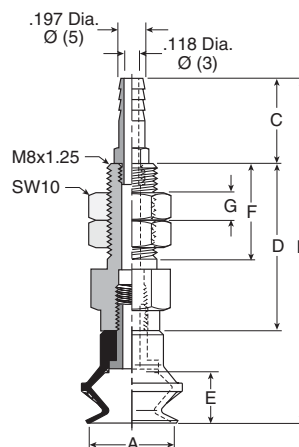

**PBTK-30 thru
 PBTK-50**

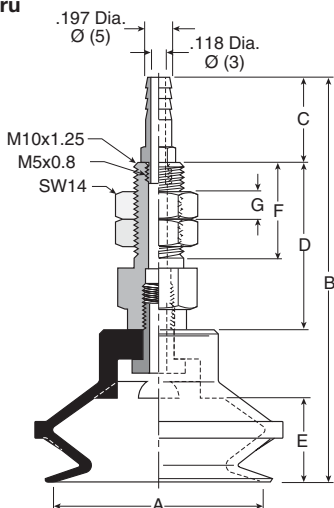

PBTK-75

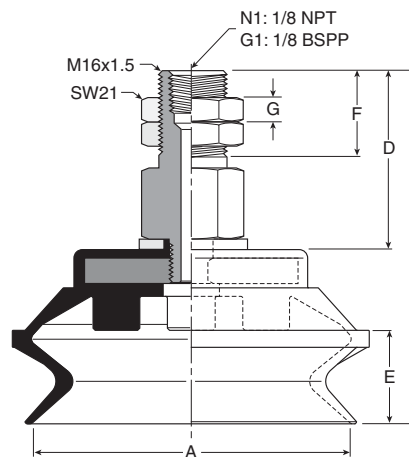

Model number	ØA	B	C	D	E	F	G	Wt oz (g)
PBTK-10A-*	.39 (10)	2.05 (52)	.39 (10)	.89 (22.5)	.30 (7.5)	.24 (6)	.61 (15.5)	.5 (15)
PBTK-15A-*	.59 (15)	2.15 (54.5)	.39 (10)	.89 (22.5)	.39 (10)	.24 (6)	.61 (15.5)	.5 (15)
PBTK-20-*	.79 (20)	2.26 (57.5)	.63 (16)	.87 (22)	.47 (12)	.24 (6)	.59 (15)	.7 (21)
PBTK-30-*	1.18 (30)	3.09 (78.5)	.63 (16)	1.26 (32)	.67 (17)	.24 (6)	.79 (20)	1.6 (45)
PBTK-40-*	1.57 (40)	3.09 (78.5)	.63 (16)	1.26 (32)	.61 (15.5)	.24 (6)	.79 (20)	1.7 (48)
PBTK-50-*	1.97 (50)	3.33 (84.5)	.63 (16)	1.26 (32)	.79 (20)	.24 (6)	.79 (20)	2.2 (62)
PBTK-75-†	3.74 (95)	3.29 (83.5)	—	1.67 (42.5)	.87 (22)	.43 (11)	—	6.5 (186)

Inches (mm)
 * Cup material
 † Vacuum port



Dimensions

**PBYK-10A thru
PBYK-15A**

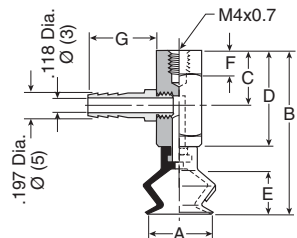

**PBYK-20 thru
PBYK-50**

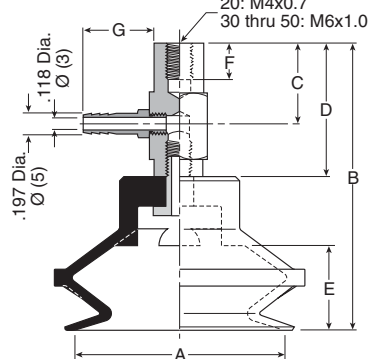

**PBYK-110 thru
PBYK-150**

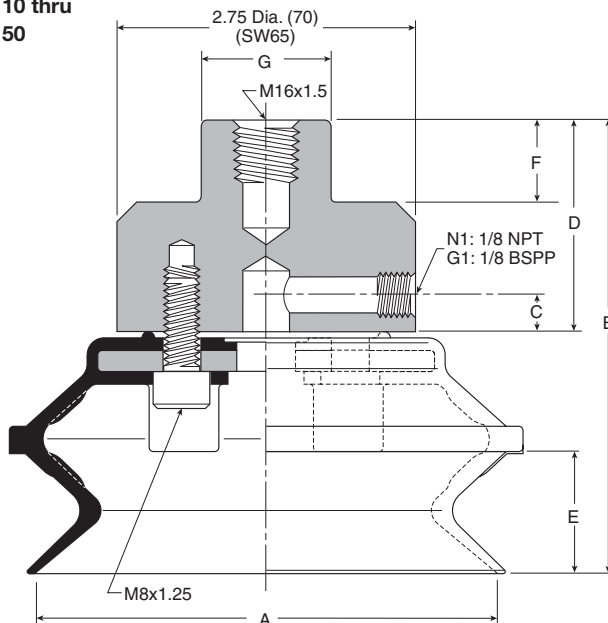

PBYK-75

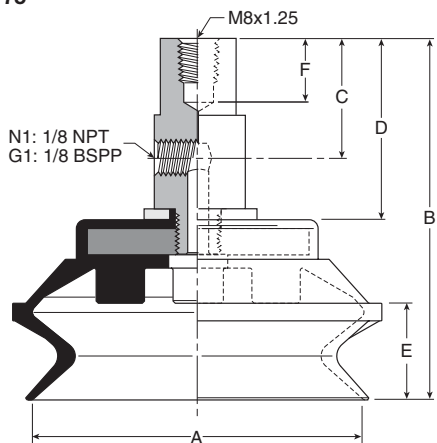

A

Technical

PFG
Flat

PBG
Bellows

P5V-CFS
Flat

PJG Short
Bellows

PCG
Multiple
Bellows

PUGB
Flat Swivel

Cup
Fittings

Model number	ØA	B	C	D	E	F	G	Wt oz (g)
PBYK-10A-*	.39 (10)	1.42 (36)	.51 (13)	.89 (22.5)	.29 (7.5)	.24 (6)	.63 (16)	.6 (16)
PBYK-15A-*	.59 (15)	1.52 (38.5)	.51 (13)	.89 (22.5)	.39 (10)	.24 (6)	.63 (16)	.6 (16)
PBYK-20-*	.79 (20)	1.63 (41.5)	.55 (14)	.87 (22)	.47 (12)	.24 (6)	.63 (16)	.7 (21)
PBYK-30-*	1.18 (30)	2.46 (62.5)	.79 (20)	1.26 (32)	.67 (17)	.24 (6)	.63 (16)	1.6 (45)
PBYK-40-*	1.57 (40)	2.46 (62.5)	.79 (20)	1.26 (32)	.61 (15.5)	.24 (6)	.63 (16)	2.0 (58)
PBYK-50-*	1.97 (50)	2.70 (68.5)	.79 (20)	1.26 (32)	.78 (20)	.24 (6)	.63 (16)	2.4 (67)
PBYK-75-*.†	3.74 (95)	3.29 (83.5)	1.10 (28)	1.67 (42.5)	.86 (22)	.43 (11)	—	6.9 (176)
PBYK-110-*.†	4.72 (120)	4.17 (106)	.47 (12)	1.97 (50)	1.14 (29)	.79 (20)	1.18 Dia. (30)	26.4 (670)
PBYK-150-*.†	5.91 (150)	4.92 (125)	.47 (12)	1.97 (50)	1.50 (38)	.79 (20)	1.18 Dia. (30)	46.5 (1180)

Inches (mm)

* Cup material

† Vacuum port



Dimensions

PBTYS10A thru
PBTYS15A1

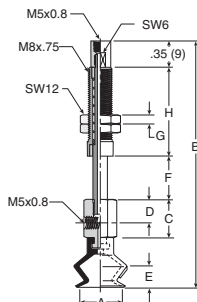

PBTYS20B thru
PBTYS50

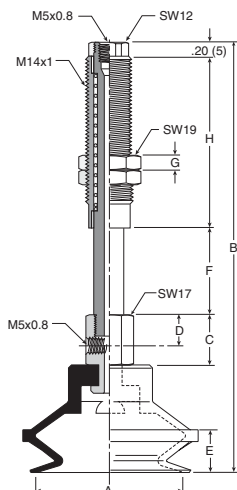

PBTYS75

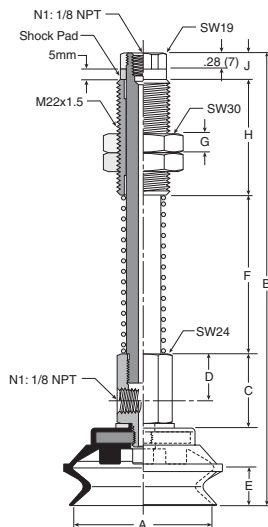

PBTYS110 thru
PBTYS150

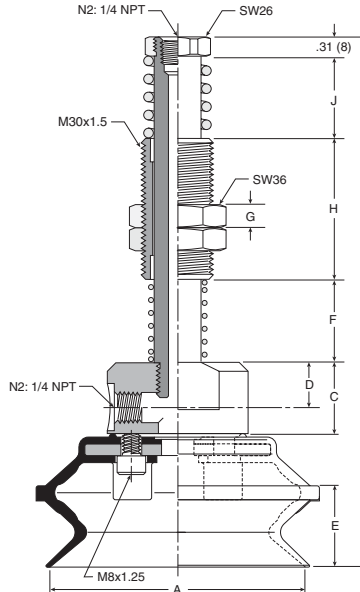

Model number	ØA	B	C	D	E	F	G	H	J	Wt oz (g)
PBTYS10A10*	.39 (10)	2.70 (68.5)	.51 (13)	.31 (8)	.30 (7.5)	.39 (10)	.12 (3)	.91 (23)	—	.65 (18.5)
PBTYS10A15*	.39 (10)	3.19 (81)	.51 (13)	.31 (8)	.30 (7.5)	.59 (15)	.12 (3)	1.20 (30.5)	—	.7 (21)
PBTYS15A10*	.59 (15)	2.80 (71)	.51 (13)	.31 (8)	.39 (10)	.39 (10)	.12 (3)	.91 (23)	—	.65 (18.5)
PBTYS15A15*	.59 (15)	3.29 (83.5)	.51 (13)	.31 (8)	.39 (10)	.59 (15)	.12 (3)	1.20 (30.5)	—	.7 (21)
PBTYS20B15*	.79 (20)	3.90 (99)	.67 (17)	.39 (10)	.47 (12)	.59 (15)	.20 (5)	1.42 (36)	—	2.5 (72)
PBTYS20B30*	.79 (20)	5.36 (136)	.67 (17)	.39 (10)	.47 (12)	1.18 (30)	.20 (5)	2.28 (58)	—	3.4 (97)
PBTYS3015*†	1.18 (30)	4.07 (103.5)	.67 (17)	.39 (10)	.67 (17)	.59 (15)	.20 (5)	1.42 (36)	—	3.4 (97)
PBTYS3030*†	1.18 (30)	5.53 (140.5)	.67 (17)	.39 (10)	.67 (17)	1.18 (30)	.20 (5)	2.28 (58)	—	3.6 (102)
PBTYS4015*†	1.57 (40)	4.07 (103.5)	.67 (17)	.39 (10)	.61 (15.5)	.59 (15)	.20 (5)	1.42 (36)	—	2.9 (83)
PBTYS4030*†	1.57 (40)	5.53 (140.5)	.67 (17)	.39 (10)	.61 (15.5)	1.18 (30)	.20 (5)	2.28 (58)	—	3.8 (108)
PBTYS5015*†	1.97 (50)	4.31 (109.5)	.67 (17)	.39 (10)	.78 (20)	.59 (15)	.20 (5)	1.42 (36)	—	3.4 (97)
PBTYS5030*†	1.97 (50)	5.77 (146.5)	.67 (17)	.39 (10)	.78 (20)	1.18 (30)	.20 (5)	2.28 (58)	—	4.3 (122)
PBTYS7530*†	2.95 (75)	7.01 (178)	1.28 (32.5)	.78 (20)	.87 (22)	1.77 (45)	.39 (10)	1.97 (50)	.47 (12)	12 (339)
PBTYS7550*†	2.95 (75)	7.99 (203)	1.28 (32.5)	.78 (20)	.87 (22)	2.76 (70)	.39 (10)	1.97 (50)	.47 (12)	13 (373)
PBTYS11020*†	4.33 (110)	8.82 (224)	1.18 (30)	.71 (18)	1.14 (29)	1.38 (35)	.39 (10)	2.36 (60)	1.38 (35)	42 (1194)
PBTYS11070*†	4.33 (110)	11.38 (289)	1.18 (30)	.71 (18)	1.14 (29)	3.94 (100)	.39 (10)	2.36 (60)	1.38 (35)	45 (1276)
PBTYS15020*†	5.91 (150)	9.57 (243)	1.18 (30)	.71 (18)	1.50 (38)	1.38 (35)	.39 (10)	2.36 (60)	1.38 (35)	60 (1704)
PBTYS15070*†	5.91 (150)	12.13 (308)	1.18 (30)	.71 (18)	1.50 (38)	3.94 (100)	.39 (10)	2.36 (60)	1.38 (35)	63 (1786)

Inches (mm)

* Cup material

† Vacuum port



Features, Ordering Information

Features

- Double sealing lips for flexible sheet handling
- Vacuum cup grooves on underside increase holding area
- Resists acceleration and deceleration shear forces
- Strong low profile for fast response
- Metal insert fitting for stable vertical and horizontal lifts

Applications

These suction cups are ideal for applications where the product may flex when being lifted. All cups have a double sealing lip and cleats to increase holding capacity. The top of the cup has a ribbed outer lip to prevent it from rolling over the surface to be lifted.

Dual sealing lips provide 2 seals for vacuum. As the product flexes, the outer lip seal may break, but the inner lip seal will hold the degree of vacuum for continued lifting capacity. In these types of applications, sizing should be done on the inner diameter cup dimension.



Cup diameter (mm)	Vacuum port	Complete assembly Nitrile (NBR)	Area*** cm ²	Cup volume (V) liters	Deflection (S) (mm)	Radius R (mm)	
						R1*	R2**
50	1/8 BSPP	P5V-CFS05011N	19.6	.001	.16 (4)	3.86 (98)	3.15 (80)
100	3/8 BSPP	P5V-CFS10013N	78.5	.0667	.30 (8)	10.00 (254)	6.34 (161)
150	1/2 BSPP	P5V-CFS15014N	176.7	.2083	.43 (11)	12.17 (309)	9.92 (252)

* Minimum permissible radius for lifting using inner lip.
 ** Minimum permissible radius for lifting using outer lip.
 *** Area based on outer cup diameter

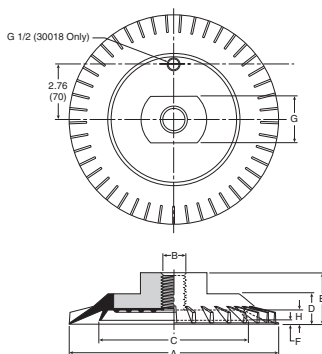
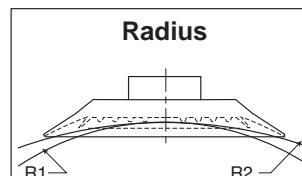
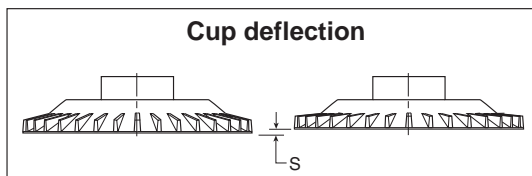
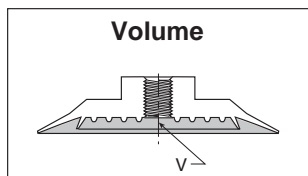

Dimensions

Model number	ØA	B	ØC	D	E	F	G	H
P5V-CFS50*	1.97 (50)	G1/8	1.38 (35)	0.43 (11)	0.71 (18)	0.087 (2.2)	0.51 (13)	0.146 (3.7)
P5V-CFS100*	3.94 (100)	G3/8	2.83 (72)	0.71 (18)	1.10 (28)	0.197 (5)	0.87 (22)	0.295 (7.5)
P5V-CFS150*	5.91 (150)	G1/2	4.17 (106)	1.02 (26)	1.65 (42)	0.276 (7)	1.06 (27)	0.43 (11)

Inches (mm)
 * Cup material

Most popular.



A
Technical
PFG Flat
PBG Bellows
P5V-CFS Flat
PJG Short Bellows
PCG Multiple Bellows
PUGB Flat Swivel
Cup Fittings

Features

Versatile bellow cup design provides increased sealing lip and level compensation for products with irregular, smooth, curved surfaces, or flexible sheets.

The short stroke bellow suction cup has an extra thin sealing edge and shorter stroke versus the traditional bellows for faster response. The cups are good for corrugated and smooth surfaces.



Features

- Short bellows for fast response
- More lip seal contact for corrugated, textured surfaces
- Soft sealing lip
- 6mm to 80mm

Styles

- PJTM series male thread connector
- PJTF series female thread connector
- PJTK series barbed bulkhead
- PJYK series 90° barbed adapter
- PJTYS series bulkhead level compensator

Specifications

Cup material	Nitrile	Nitrile ESD*	Silicon	Silicon ESD*
Material code	NBR	NBRE	SI	SIE
Operating temperature (°C)	-20° to +120°	0° to +60°	-60° to +250°	-10° to +130°
Color	Black	Black / Blue Dot	White	Black / Red Dot
Hardness, shore A (°Sh)	55 ±5	70 ±5	55 ±5	55 ±5
Electrical resistance (Ωm)	—	800 to 1000	—	5 to 15

* ESD: Electric Static Dissipative Material

How to order

Cups assemblies and replacement cups are specified by cup diameter and material. Standard nitrile and silicon are listed on the following pages. To specify an alternative material, replace the cup material with alternative cup material code.

Example: To specify a cup assembly with silicon ESD (SIE), replace (NBR) with (SIE) in the part number. PJTM-20B-NBR-G1 becomes PJTM-20B-SIE-G1. Inquire with factory for availability.

Application guide

Short Bellows



Flat surface, thin section	Flat surface, any section	Slightly bowed surface, thin section	Slightly bowed surface, any section	Bowed surface, thin section	Soft porous material, thin section	Soft porous material, any section	Metal sheet handling	Corrugated sheet handling	Not for vertical lift
----------------------------	---------------------------	--------------------------------------	-------------------------------------	-----------------------------	------------------------------------	-----------------------------------	----------------------	---------------------------	-----------------------



Ordering Information

PJTM Series Male Thread Connector

Simple male connection for low profile positions secured to a plate or bracket. NPT, G, metric threads.
 Fitting material: aluminum.

Installation

Note:
 When installing cup assemblies, use a sealant material to secure the assembly and prevent vacuum leakage.

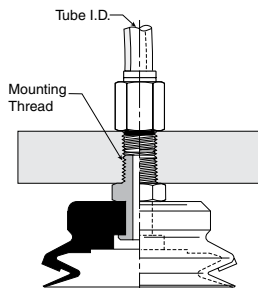

A

Technical

PFG Flat

PBG Bellows

P5V-CFS Flat

PJG Short Bellows

PCG Multiple Bellows

PUGB Flat Swivel

Cup Fittings

Cup diameter (mm)	Vacuum port	Complete assembly Nitrile	Replacement cup Nitrile (NB)	Complete assembly Silicon (SI)	Replacement cup Silicon (SI)	Replacement cup fitting
6	M5	PJTM-6-NBR-M5	PJG-6-NBR	PJTM-6-SI-M5	PJG-6-SI	FTM-5A-M5H
6	1/8 BSPP	PJTM-6-NBR-G1	PJG-6-NBR	PJTM-6-SI-G1	PJG-6-SI	FTM-5A-G1
8	M5	PJTM-8-NBR-M5	PJG-8-NBR	PJTM-8-SI-M5	PJG-8-SI	FTM-5A-M5H
8	1/8 BSPP	PJTM-8-NBR-G1	PJG-8-NBR	PJTM-8-SI-G1	PJG-8-SI	FTM-5A-G1
10	M5	PJTM-10-NBR-M5	PJG-10-NBR	PJTM-10-SI-M5	PJG-10-SI	TN-PF-15-M5
15	M5	PJTM-15-NBR-M5	PJG-15-NBR	PJTM-15-SI-M5	PJG-15-SI	TN-PF-15-M5
20	M5	PJTM-20-NBR-M5	PJG-20-NBR	PJTM-20-SI-M5	PJG-20-SI	TN-PF-20-M5
30	1/8 BSPP	PJTM-30-NBR-G1	PJG-30-NBR	PJTM-30-SI-G1	PJG-30-SI	FTM-20B-G1H
30	1/4 BSPP	PJTM-30-NBR-G2	PJG-30-NBR	PJTM-30-SI-G2	PJG-30-SI	FTM-20B-G2
30	M10	PJTM-30-NBR-M10	PJG-30-NBR	PJTM-30-SI-M10	PJG-30-SI	FTM-20B-M10
30	1/8 NPT	PJTM-30-NBR-N1	PJG-30-NBR	PJTM-30-SI-N1	PJG-30-SI	FTM-20B-N1
40	1/8 BSPP	PJTM-40-NBR-G1	PJG-40-NBR	PJTM-40-SI-G1	PJG-40-SI	FTM-20B-G1H
40	1/4 BSPP	PJTM-40-NBR-G2	PJG-40-NBR	PJTM-40-SI-G2	PJG-40-SI	FTM-20B-G2
40	M10	PJTM-40-NBR-M10	PJG-40-NBR	PJTM-40-SI-M10	PJG-40-SI	FTM-20B-M10
40	1/8 NPT	PJTM-40-NBR-N1	PJG-40-NBR	PJTM-40-SI-N1	PJG-40-SI	FTM-20B-N1
50	1/8 BSPP	PJTM-50-NBR-G1	PJG-50-NBR	PJTM-50-SI-G1	PJG-50-SI	FTM-50-G1H
50	1/4 BSPP	PJTM-50-NBR-G2	PJG-50-NBR	PJTM-50-SI-G2	PJG-50-SI	FTM-50-G2
50	1/8 NPT	PJTM-50-NBR-N1	PJG-50-NBR	PJTM-50-SI-N1	PJG-50-SI	FTM-50-N1
60	1/4 BSPP	PJTM-60-NBR-G2	PJG-60-NBR	PJTM-60-SI-G2	PJG-60-SI	FTM-60-G2
60	M10	PJTM-60-NBR-M10	PJG-60-NBR	PJTM-60-SI-M10	PJG-60-SI	FTM-60-M10
60	1/4 NPT	PJTM-60-NBR-N2	PJG-60-NBR	PJTM-60-SI-N2	PJG-60-SI	FTM-60-N2
80	1/4 BSPP	PJTM-80-NBR-G2	PJG-80-NBR	PJTM-80-SI-G2	PJG-80-SI	FTM-60-G2
80	M10	PJTM-80-NBR-M10	PJG-80-NBR	PJTM-80-SI-M10	PJG-80-SI	FTM-60-M10
80	1/4 NPT	PJTM-80-NBR-N2	PJG-80-NBR	PJTM-80-SI-N2	PJG-80-SI	FTM-60-N2

☐ Most popular.



A

PJTF Series Female Thread Connector

Simple female connection for low profile positions secured to a plate or bracket. NPSF, G threads. Fitting material: aluminum.

Installation

Note:

When installing cup assemblies, use a sealant material to secure the assembly and prevent vacuum leakage.

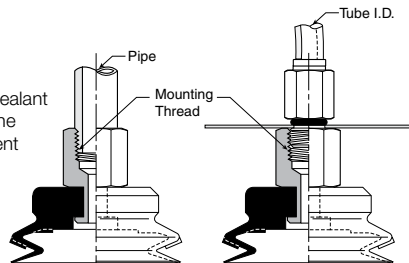

- Technical
- PFg Flat
- PGg Bellows
- PGV-CFS Flat
- PJG Short Bellows
- PCg Multiple Bellows
- PUGB Flat Swivel
- Cup Fittings

Cup diameter (mm)	Vacuum port	Complete assembly Nitrile	Replacement cup Nitrile (NB)	Complete assembly Silicon (SI)	Replacement cup Silicon (SI)	Replacement cup fitting
6	M5	PJTF-6-NBR-M5	PJG-6-NBR	PJTF-6-SI-M5	PJG-6-SI	FTF-5A-M5
6	1/8 BSPP	PJTF-6-NBR-G1	PJG-6-NBR	PJTF-6-SI-G1	PJG-6-SI	FTF-5A-G1
8	M5	PJTF-8-NBR-M5	PJG-8-NBR	PJTF--8-SI-M5	PJG-8-SI	FTF-5A-M5
8	1/8 BSPP	PJTF-8-NBR-G1	PJG-8-NBR	PJTF--8-SI-G1	PJG-8-SI	FTF-5A-G1
10	M5	PJTF-10-NBR-M5	PJG-10-NBR	PJTF-10-SI-M5	PJG-10-SI	FTF-5A-M5
10	1/8 BSPP	PJTF-10-NBR-G1	PJG-10-NBR	PJTF-10-SI-G1	PJG-10-SI	FTF-5A-G1
15	M5	PJTF-15-NBR-M5	PJG-15-NBR	PJTF-15-SI-M5	PJG-15-SI	FTF-5A-M5
15	1/8 BSPP	PJTF-15-NBR-G1	PJG-15-NBR	PJTF-15-SI-G1	PJG-15-SI	FTF-5A-G1
30	1/8 BSPP	PJTF-30-NBR-G1	PJG-30-NBR	PJTF-30-SI-G1	PJG-30-SI	FTF-20B-G1
30	1/4 BSPP	PJTF-30-NBR-G2	PJG-30-NBR	PJTF-30-SI-G2	PJG-30-SI	FTF-20B-G2
40	1/8 BSPP	PJTF-40-NBR-G1	PJG-40-NBR	PJTF-40-SI-G1	PJG-40-SI	FTF-20B-G1
40	1/4 BSPP	PJTF-40-NBR-G2	PJG-40-NBR	PJTF-40-SI-G2	PJG-40-SI	FTF-20B-G2
50	1/8 BSPP	PJTF-50-NBR-G1	PJG-50-NBR	PJTF-50-SI-G1	PJG-50-SI	FTF-50-G1
50	1/4 BSPP	PJTF-50-NBR-G2	PJG-50-NBR	PJTF-50-SI-G2	PJG-50-SI	FTF-50-G2
60	1/4 BSPP	PJTF-60-NBR-G2	PJG-60-NBR	PJTF-60-SI-G2	PJG-60-SI	FTF-60-G2
60	1/4 NPT	PJTF-60-NBR-N2	PJG-60-NBR	PJTF-60-SI-N2	PJG-60-SI	FTF-60-N2
80	1/4 BSPP	PJTF-80-NBR-G2	PJG-80-NBR	PJTF-80-SI-G2	PJG-80-SI	FTF-60-G2
80	1/4 NPT	PJTF-80-NBR-N2	PJG-80-NBR	PJTF-80-SI-N2	PJG-80-SI	FTF-60-N2

☐ Most popular.



Ordering Information

PJTK Series Barbed Bulkhead

Top stem connectors secured with jam nuts and allow tubing connections at the top side. Fitting material: nickel plated brass.

Installation

Note:

When installing cup assemblies, use a sealant material to secure the assembly and prevent vacuum leakage.

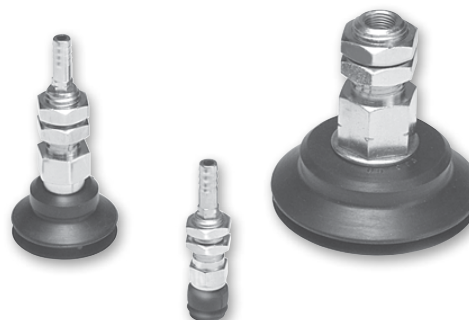
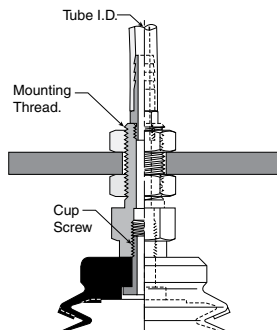

Cup diameter (mm)	Vacuum port	Complete assembly Nitrile	Replacement cup Nitrile (NB)	Complete assembly Silicon (SI)	Replacement cup Silicon (SI)	Replacement cup fitting
6	Barb	PJTK-6-NBR	PJG-6-NBR	PJTK-6-SI	PJG-6-SI	FTK-5A
8	Barb	PJTK-8-NBR	PJG-8-NBR	PJTK-8-SI	PJG-8-SI	FTK-5A
10	Barb	PJTK-10-NBR	PJG-10-NBR	PJTK-10-SI	PJG-10-SI	FTK-15
15	Barb	PJTK-15-NBR	PJG-15-NBR	PJTK-15-SI	PJG-15-SI	FTK-15
20	Barb	PJTK-20-NBR	PJG-20-NBR	PJTK-20-SI	PJG-20-SI	FTK-20
30	Barb	PJTK-30-NBR	PJG-30-NBR	PJTK-30-SI	PJG-30-SI	FTK-25
40	Barb	PJTK-40-NBR	PJG-40-NBR	PJTK-40-SI	PJG-40-SI	FTK-25
50	Barb	PJTK-50-NBR	PJG-50-NBR	PJTK-50-SI	PJG-50-SI	FTK-50
60	1/8 BSPP	PJTK-60-NBR-G1	PJG-60-NBR	PJTK-60-SI-G1	PJG-60-SI	FTK-60-G1
60	1/8 NPT	PJTK-60-NBR-N1	PJG-60-NBR	PJTK-60-SI-N1	PJG-60-SI	FTK-60-N1
80	1/8 BSPP	PJTK-80-NBR-G1	PJG-80-NBR	PJTK-80-SI-G1	PJG-80-SI	FTK-60-G1
80	1/8 NPT	PJTK-80-NBR-N1	PJG-80-NBR	PJTK-80-SI-N1	PJG-80-SI	FTK-60-N1

Most popular.



A

Technical

PFG Flat

PBG Bellows

P5V-CFS Flat

PJG Short Bellows

PCG Multiple Bellows

PIUGB Flat Swivel

Cup Fittings

PJYK Series 90° Barbed Adapter

Side stem connectors allow you to secure the stem with a bolt through a plate or "L" bracket to allow the tube connection from the side port. Fitting material: nickel plated brass.

Installation

Note:
 When installing cup assemblies, use a sealant material to secure the assembly and prevent vacuum leakage.

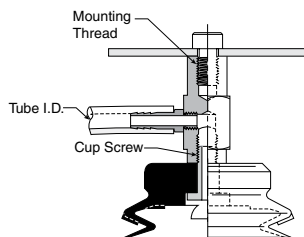

- A
- Technical
- PFG Flat
- PBG Bellows
- PJV-CFS Flat
- PJG Short Bellows
- PCG Multiple Bellows
- PUGB Flat Swivel
- Cup Fittings

Cup diameter (mm)	Vacuum port	Complete assembly Nitrile	Replacement cup Nitrile (NB)	Complete assembly Silicon (SI)	Replacement cup Silicon (SI)	Replacement cup fitting
6	Barb	PJYK-6-NBR	PJG-6-NBR	PJYK-6-SI	PJG-6-SI	FYK-5A
8	Barb	PJYK-8-NBR	PJG-8-NBR	PJYK-8-SI	PJG-8-SI	FYK-5A
10	Barb	PJYK-10-NBR	PJG-10-NBR	PJYK-10-SI	PJG-10-SI	FYK-15
15	Barb	PJYK-15-NBR	PJG-15-NBR	PJYK-15-SI	PJG-15-SI	FYK-15
20	Barb	PJYK-20-NBR	PJG-20-NBR	PJYK-20-SI	PJG-20-SI	FYK-20
30	Barb	PJYK-30-NBR	PJG-30-NBR	PJYK-30-SI	PJG-30-SI	FYK-25
40	Barb	PJYK-40-NBR	PJG-40-NBR	PJYK-40-SI	PJG-40-SI	FYK-25
50	Barb	PJYK-50-NBR	PJG-50-NBR	PJYK-50-SI	PJG-50-SI	FYK-50
60	1/8 BSPP	PJYK-60-NBR-G1	PJG-60-NBR	PJYK-60-SI-G1	PJG-60-SI	FYK-60-G1
60	1/8 NPT	PJYK-60-NBR-N1	PJG-60-NBR	PJYK-60-SI-N1	PJG-60-SI	FYK-60-N1
80	1/8 BSPP	PJYK-80-NBR-G1	PJG-80-NBR	PJYK-80-SI-G1	PJG-80-SI	FYK-60-G1
80	1/8 NPT	PJYK-80-NBR-N1	PJG-80-NBR	PJYK-80-SI-N1	PJG-80-SI	FYK-60-N1

Most popular.



Ordering Information

PJTYS Series Bulkhead Level Compensator

303 stainless steel construction secured with jam nuts. Spring biased compensators can absorb impacts of down-strokes and adjust for different levels of pick up points. 303 stainless corrosion resistant materials with drymet bushings increases the strength and life.

Installation

Note:

When installing cup assemblies, use a sealant material to secure the assembly and prevent vacuum leakage. Shown are interchangeable connectors & plugs for port connections.

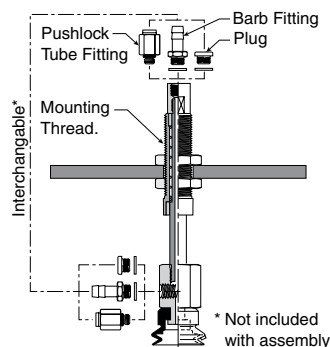

Cup dia. (mm)	Vacuum port	Stroke (mm)	Spring compression Force lbf (N)		Cup material Nitrile assembly (NBR)	Replacement cup Nitrile (NBR)	Cup material Silicon assembly (SI)	Replacement cup Silicon (SI)	Level Compensator P/N
			0%	100%					
10	M5	10	.56 (2.5)	1.2 (4.9)	PJTYS1010NBRM5	PJG-10-NBR	PJTYS1010SIM5	PJG-10-SI	JTYS-10-10
10	M5	15	.67 (2.5)	1.4 (5.9)	PJTYS1015NBRM5	PJG-10-NBR	PJTYS1015SIM5	PJG-10-SI	JTYS-10-15
15	M5	10	.56 (2.5)	1.2 (4.9)	PJTYS15A10NBRM5	PJG-15A-NBR	PJTYS15A10SIM5	PJG-15A-SI	JTYS-10-10
15	M5	15	.67 (2.5)	1.4 (5.9)	PJTYS15A15NBRM5	PJG-15A-NBR	PJTYS15A15SIM5	PJG-15A-SI	JTYS-10-15
30	M5	15	.56 (2.5)	.79 (3.4)	PJTYS3015NBRM5	PJG-30-NBR	PJTYS3015SIM5	PJG-30-SI	TYS-20B-15
30	M5	30	.67 (2.9)	1.4 (5.9)	PJTYS3030NBRM5	PJG-30-NBR	PJTYS3030SIM5	PJG-30-SI	TYS-20B-30
40	M5	15	.56 (2.5)	.79 (3.4)	PJTYS4015NBRM5	PJG-40-NBR	PJTYS4015SIM5	PJG-40-SI	TYS-20B-15
40	M5	30	.67 (2.9)	1.4 (5.9)	PJTYS4030NBRM5	PJG-40-NBR	PJTYS4030SIM5	PJG-40-SI	TYS-20B-30
50	M5	15	.56 (.25)	1.2 (4.9)	PJTYS5015NBRM5	PJG-50-NBR	PJTYS5015SIM5	PJG-50-SI	TYS-50-15
50	M5	30	.67 (2.9)	1.4 (5.9)	PJTYS5030NBRM5	PJG-50-NBR	PJTYS5030SIM5	PJG-50-SI	TYS-50-30
60	1/8 NPT	30	1.6 (6.8)	3.6 (15.6)	PJTYS6030NBRN1	PJG-60-NBR	PJTYS6030SIN1	PJG-60-SI	TYS-60-30
60	1/8 NPT	50	1.9 (8.3)	4.5 (19.6)	PJTYS6050NBRN1	PJG-60-NBR	PJTYS6050SIN1	PJG-60-SI	TYS-60-50
80	1/8 NPT	30	1.6 (6.8)	3.6 (15.6)	PJTYS8030NBRN1	PJG-80-NBR	PJTYS8030SIN1	PJG-80-SI	TYS-60-30
80	1/8 NPT	50	1.9 (8.3)	4.5 (19.6)	PJTYS8050NBRN1	PJG-80-NBR	PJTYS8050SIN1	PJG-80-SI	TYS-60-50

☐ Most popular.



A

Technical

PFG Flat

PBG Bellows

P5V-CFS Flat

PJK Short Bellows

PCG Multiple Bellows

PIUGB Flat Swivel

Cup Fittings

A

Technical

 PFG
Flat

 PBG
Bellows

 P5V-CFS
Flat

 PJG Short
Bellows

 PCG
Multiple
Bellows

 PUGB
Flat Swivel

 Cup
Fittings

Applications

- High speed packaging
- Level compensation for small electronic components
- Flexible product
- Soft seal lip

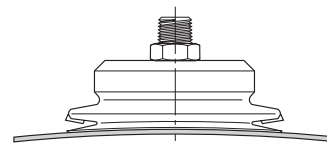
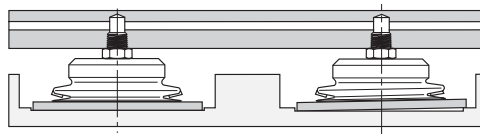
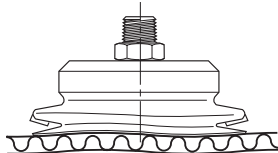
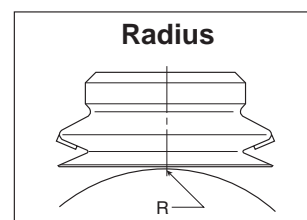
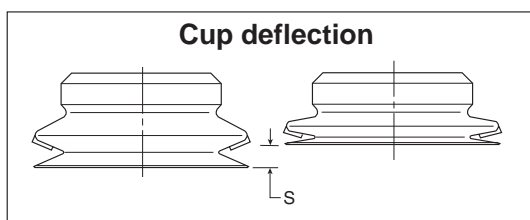
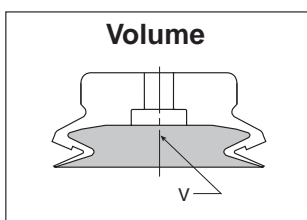
Main data for short bellows PJG cups

Model number	Cup diameter inches (mm)	Area cm ²	Volume (V) liters	Lifting force @ 60% (N)		Cup deflection (S) mm	Radius R (mm)
PJG-6-*	.24 (6)	.28	0.000016	1.70	—	4.2	4.0
PJG-8-*	.31 (8)	.50	0.00007	3.10	—	4.0	5.0
PJG-10-*	.39 (10)	0.79	0.00017	4.80	—	3.0	6.0
PJG-15-*	.59 (15)	1.77	0.0005	10.8	—	3.3	10.0
PJG-20-*	.79 (20)	3.14	0.0012	19.2	—	5.5	13.0
PJG-30-*	1.18 (30)	7.07	0.003	43.2	—	7.0	26.0
PJG-40-*	1.57 (40)	12.6	0.005	76.9	—	7.2	37.0
PJG-50-*	1.97 (50)	19.6	0.008	120	—	9.0	41.0
PJG-60-*	2.36 (60)	28.3	0.020	173	—	8.0	70.0
PJG-80-*	3.15 (80)	50.3	0.040	308	—	9.5	100.0

*Cup material

Dimensions

PJG Series Replacement Cup Dimensions

PJG-6 and PJG-8

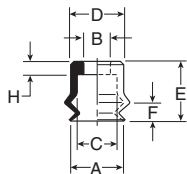

PJG-10 and PJG-15

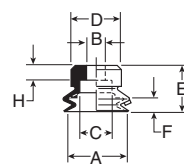

PJG-20

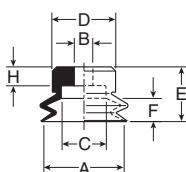

PJG-30 thru PJG-40

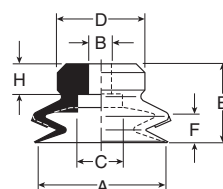

PJG-50

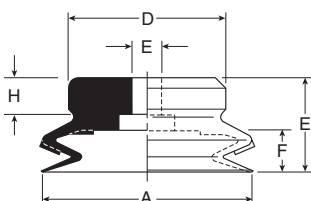

PJG-60 thru PJG-80

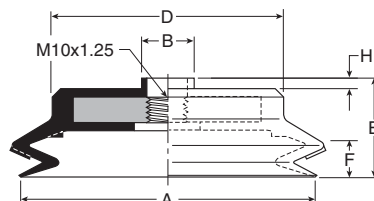

A

Technical

PFG Flat

PBG Bellows

P5V-CFS Flat

PJG Short Bellows

PCG Multiple Bellows

PUGB Flat Swivel

Cup Fittings

Model number	ØA	ØB	ØC	ØD	E	F	H
PJG-6-*	.24 (6)	.16 (4)	.24 (6)	.30 (7.5)	.35 (9)	.17 (4.2)	.08 (2)
PJG-8-*	.31 (8)	.16 (4)	.24 (6)	.31 (8)	.35 (9)	.16 (4)	.08 (2)
PJG-10-*	.39 (10)	.18 (4.6)	.31 (7.8)	.43 (11)	.37 (9.5)	.12 (3)	.14 (3.5)
PJG-15-*	.59 (15)	.18 (4.6)	.31 (7.8)	.47 (12)	.43 (11)	.13 (3.3)	.14 (3.5)
PJG-20-*	.79 (20)	.18 (4.6)	.43 (10.8)	.59 (15)	.51 (13)	.22 (5.5)	.18 (4.5)
PJG-30-*	1.18 (30)	.23 (5.8)	.43 (10.8)	.78 (20)	.71 (18)	.28 (7)	.28 (7)
PJG-35-*	1.38 (35)	.23 (5.8)	.43 (10.8)	.98 (25)	.71 (18)	.28 (7)	.28 (7)
PJG-40-*	1.57 (40)	.23 (5.8)	.43 (10.8)	1.18 (30)	.71 (18)	.28 (7.2)	.28 (7)
PJG-50-*	1.97 (50)	.31 (7.8)	.78 (19.8)	1.57 (40)	.79 (20)	.35 (9)	.28 (7)
PJG-60-*	2.36 (60)	.49 (12.5)	—	1.77 (45)	.89 (22.5)	.31 (8)	.10 (2.5)
PJG-70-*	2.75 (70)	.49 (12.5)	—	2.17 (55)	.93 (23.5)	.37 (9.5)	.10 (2.5)
PJG-80-*	3.15 (80)	.49 (12.5)	—	2.68 (68)	.93 (23.5)	.37 (9.5)	.10 (2.5)

Inches (mm)

* Cup material



- A
- Technical
- PFG
Flat
- PBG
Bellows
- P5V-CFS
Flat
- PUG Short
Bellows
- PCG
Multiple
Bellows
- PUGB
Flat Swivel
- Cup
Fittings

Dimensions

**PJTM-6 and
 PJTM-8**

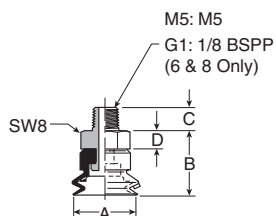

**PJTM-10 thru
 PJTM-20**

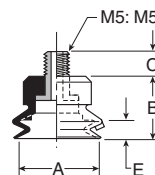

**PJTM-30 thru
 PJTM-50**

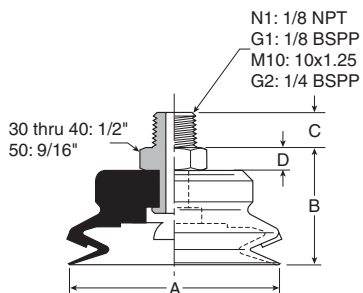

**PJTM-60 thru
 PJTM-80**

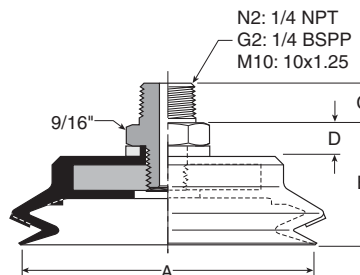

Model number	ØA	B	C (M5)	C (N1 / G1)	C (M10 / G2)	C (N2)	D
PJTM-6- [*] †	.24 (6)	.49 (12.5)	.18 (4.5)	.31 (8)	—	—	.14 (3.5)
PJTM-8- [*] †	.31 (8)	.49 (12.5)	.18 (4.5)	.31 (8)	—	—	.14 (3.5)
PJTM-10- [*] †	.39 (10)	.37 (9.5)	.20 (5)	—	—	—	—
PJTM-15- [*] †	.59 (15)	.43 (11)	.20 (5)	—	—	—	—
PJTM-20- [*] †	.79 (20)	.51 (13)	.20 (5)	—	—	—	—
PJTM-30- [*] †	1.18 (30)	.91 (23)	—	.31 (8)	.39 (10)	—	.20 (5)
PJTM-40- [*] †	1.57 (40)	.91 (23)	—	.31 (8)	.39 (10)	—	.20 (5)
PJTM-50- [*] †	1.97 (50)	.98 (25)	—	.31 (8)	.39 (10)	—	.20 (5)
PJTM-60- [*] †	2.36 (60)	1.06 (27)	—	—	.39 (10)	.59 (15)	.28 (7)
PJTM-80- [*] †	3.15 (80)	1.10 (28)	—	—	.39 (10)	.59 (15)	.28 (7)

Inches (mm)
^{*} Cup material
[†] Thread size



Dimensions

**PJTF-6 and
 PJTF-8**

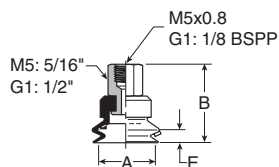

**PJTF-30 thru
 PJTF-50**

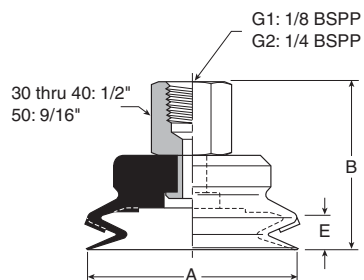

**PJTF-60 thru
 PJTF-80**

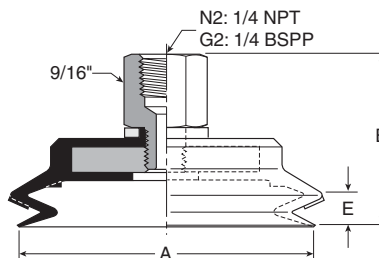

A

Technical

PFG
 Flat

PBG
 Bellows

P5V-CFS
 Flat

PJG Short
 Bellows

PCG
 Multiple
 Bellows

PUGB
 Flat Swivel

Cup
 Fittings

Model number	ØA	B	B (M5)	E
PJTF-6-*.†	.24 (6)	.79 (20)	.55 (14)	.16 (4)
PJTF-8-*.†	.31 (8)	.79 (20)	.55 (14)	.16 (4)
PJTF-10-*.†	.39 (10)	.79 (20)	.55 (14)	.12 (3)
PJTF-15-*.†	.59 (15)	.79 (20)	.55 (14)	.13 (3.3)
PJTF-30-*.†	1.18 (30)	1.25 (32)	—	.28 (7)
PJTF-40-*.†	1.57 (40)	1.25(32)	—	.28 (7.2)
PJTF-50-*.†	1.97 (50)	1.34 (34)	—	.35 (9)
PJTF-60-*.†	2.36 (60)	1.56 (39.5)	—	.31 (8)
PJTF-80-*.†	3.15 (80)	1.59 (40.5)	—	.37 (9.5)

Inches (mm)
 * Cup material
 † Thread size

- A**
- Technical
- PFG Flat
- PBG Bellows
- P5V-CFS Flat
- PUG Short Bellows
- PCG Multiple Bellows
- PUGB Flat Swivel
- Cup Fittings

Dimensions

PJTK-6 and PJTK-8

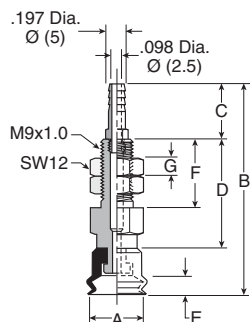

PJTK-10 thru PJTK-20

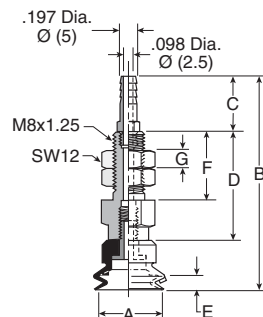

PJTK-30 thru PJTK-50

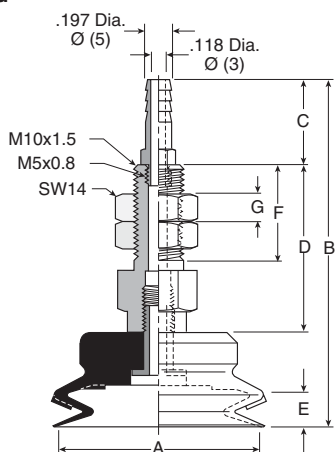

PJTK-60 thru PJTK-80

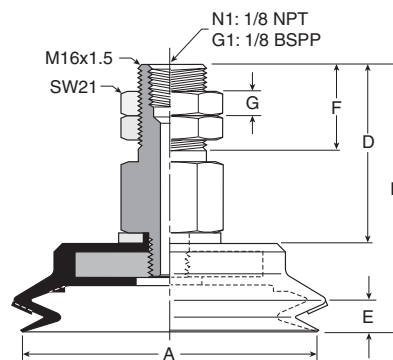

Model number	ØA	B	C	D	E	F	G	Wt oz (g)
PJTK-6-*	.24 (6)	1.30 (33)	.39 (10)	.55 (14)	.17 (4.2)	.47 (12)	.12 (3)	.4 (11)
PJTK-8-*	.31 (8)	1.30 (33)	.39 (10)	.55 (14)	.16 (4)	.47 (12)	.12 (3)	.4 (11)
PJTK-10-*	.39 (10)	1.87 (47.5)	.63 (16)	.87 (22)	.12 (3)	.59 (15)	.12 (3)	.5 (14)
PJTK-15-*	.59 (15)	1.93 (49)	.63 (16)	.87 (22)	.13 (3.3)	.59 (15)	.12 (3)	.5 (15)
PJTK-20-*	.79 (20)	2.01 (51)	.63 (16)	.87 (22)	.22 (5.5)	.59 (15)	.20 (5)	.6 (17)
PJTK-30-*	1.18 (30)	2.60 (66)	.63 (16)	1.26 (32)	.28 (7)	.79 (20)	.20 (5)	1.5 (42)
PJTK-40-*	1.57 (40)	2.60 (66)	.63 (16)	1.26 (32)	.28 (7.2)	.79 (20)	.20 (5)	1.6 (44)
PJTK-50-*	1.97 (50)	2.68 (68)	.63 (16)	1.26 (32)	.35 (9)	.79 (20)	.20 (5)	25.0 (58)
PJTK-60-*†	2.36 (60)	2.46 (62.5)	—	1.67 (42.5)	.31 (8)	.79 (20)	.24 (6)	5.1 (144)
PJTK-80-*†	3.15 (80)	2.50 (63.5)	—	1.67 (42.5)	.37 (9.5)	.79 (20)	.24 (6)	6.7 (190)

Inches (mm)
 * Cup material
 † Vacuum port



Dimensions

**PJYK-6 and
 PJYK-8**

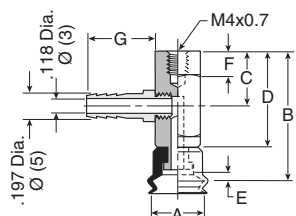

**PJYK-10 thru
 PJYK-20**

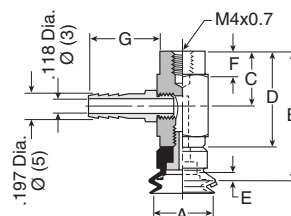

**PJYK-25 thru
 PJYK-50**

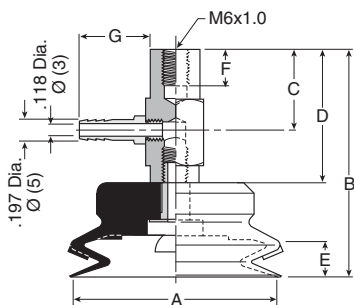

**PJYK-60 thru
 PJYK-80**

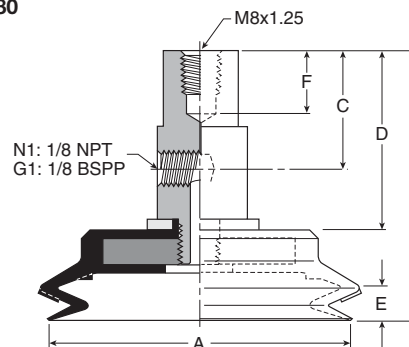

A

Technical

PFG
 Flat

PBG
 Bellows

P5V-CFS
 Flat

PJG Short
 Bellows

PCG
 Multiple
 Bellows

PUGB
 Flat Swivel

Cup
 Fittings

Model number	ØA	B	C	D	E	F	G	Wt oz (g)
PJYK-6-*	.24 (6)	1.24 (31.5)	.51 (13)	.89 (22.5)	.17 (4.2)	.24 (6)	.63 (16)	.56 (16)
PJYK-8-*	.31 (8)	1.24 (31.5)	.51 (13)	.89 (22.5)	.17 (4.2)	.24 (6)	.63 (16)	.56 (16)
PJYK-10-*	.39 (10)	1.24 (31.5)	.55 (14)	.87 (22)	.12 (3)	.24 (6)	.63 (16)	.59 (17)
PJYK-15-*	.59 (15)	1.30 (33)	.55 (14)	.87 (22)	.13 (3.3)	.24 (6)	.63 (16)	.63 (18)
PJYK-20-*	.79 (20)	1.38 (35)	.55 (14)	.87 (22)	.22 (5.5)	.24 (6)	.63 (16)	.7 (20)
PJYK-30-*	1.18 (30)	1.97 (50)	.79 (20)	1.26 (32)	.28 (7)	.31 (8)	.63 (16)	1.6 (46)
PJYK-40-*	1.57 (40)	1.97 (50)	.79 (20)	1.26 (32)	.28 (7.2)	.31 (8)	.63 (16)	1.7 (48)
PJYK-50-*	1.97 (50)	2.05 (52)	.79 (20)	1.26 (32)	.35 (9)	.31 (8)	.63 (16)	2.2 (62)
PJYK-60-*†	2.36 (60)	2.46 (62.5)	1.10 (28)	1.67 (42.5)	.31 (8)	.43 (11)	—	4.9 (139)
PJYK-80-*†	3.15 (80)	2.50 (63.5)	1.10 (28)	1.67 (42.5)	.37 (9.5)	.43 (11)	—	6.5 (185)

Inches (mm)
 * Cup material
 † Vacuum port



- A
- Technical
- PFG
Flat
- PBG
Bellows
- P5V-CFS
Flat
- PJG Short
Bellows
- PCG
Multiple
Bellows
- PUGB
Flat Swivel
- Cup
Fittings

Dimensions

PJTYS10 thru
PJTYS20

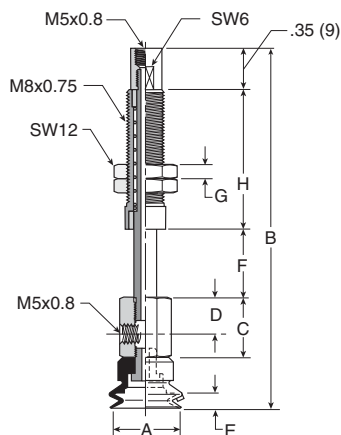

PJTYS30 thru
PJTYS50

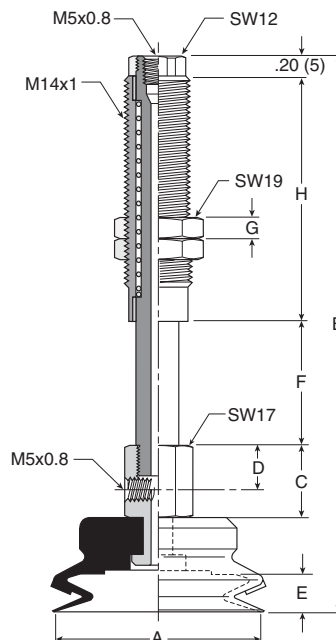

Model number	ØA	B	C	D	E	F	G	H	Wt oz (g)
PJTYS1010**†	.39 (10)	2.52 (64)	.51 (13)	.31 (8)	.12 (3)	.39 (10)	.20 (5)	.91 (23)	1.1 (31)
PJTYS1015**†	.39 (10)	3.01 (76.5)	.51 (13)	.31 (8)	.12 (3)	.59 (15)	.20 (5)	1.20 (30.5)	1.2 (33.5)
PJTYS1510**†	.59 (15)	2.60 (66)	.51 (13)	.31 (8)	.13 (3.3)	.39 (10)	.20 (5)	.91 (23)	1.1 (32)
PJTYS1515**†	.59 (15)	3.07 (78)	.51 (13)	.31 (8)	.13 (3.3)	.59 (15)	.20 (5)	1.20 (30.5)	1.3 (34.5)
PJTYS2010**†	.79 (20)	2.83 (72)	.51 (13)	.31 (8)	.22 (5.5)	.39 (10)	.20 (5)	.91 (23)	1.1 (32)
PJTYS2015**†	.79 (20)	4.29 (109)	.51 (13)	.31 (8)	.22 (5.5)	.59 (15)	.20 (5)	1.20 (30.5)	1.3 (34.5)
PJTYS3015**†	1.18 (30)	3.58 (91)	.67 (17)	.39 (10)	.28 (7)	.59 (15)	.20 (5)	1.42 (36)	2.6 (74)
PJTYS3030**†	1.18 (30)	5.04 (128)	.67 (17)	.39 (10)	.28 (7)	1.18 (30)	.20 (5)	2.28 (58)	3.5 (99)
PJTYS3515**†	1.38 (35)	3.58 (91)	.67 (17)	.39 (10)	.28 (7)	.59 (15)	.20 (5)	1.42 (36)	2.7 (76.5)
PJTYS3530**†	1.38 (35)	5.04 (128)	.67 (17)	.39 (10)	.28 (7)	1.18 (30)	.20 (5)	2.28 (58)	3.6 (101.5)
PJTYS4015**†	1.57 (40)	3.58 (91)	.67 (17)	.39 (10)	.28 (7.2)	.59 (15)	.20 (5)	1.42 (36)	2.8 (78.5)
PJTYS4030**†	1.57 (40)	5.04 (128)	.67 (17)	.39 (10)	.28 (7.2)	1.18 (30)	.20 (5)	2.28 (58)	3.7 (103.5)
PJTYS5015**†	1.97 (50)	3.66 (93)	.67 (17)	.39 (10)	.35 (9)	.59 (15)	.20 (5)	1.42 (36)	3.3 (94)
PJTYS5030**†	1.97 (50)	5.12 (130)	.67 (17)	.39 (10)	.35 (9)	1.18 (30)	.20 (5)	2.28 (58)	4.2 (119)

Inches (mm)
** Cup material
† Vacuum port



Dimensions

**PJTYS60 thru
PJTYS80**

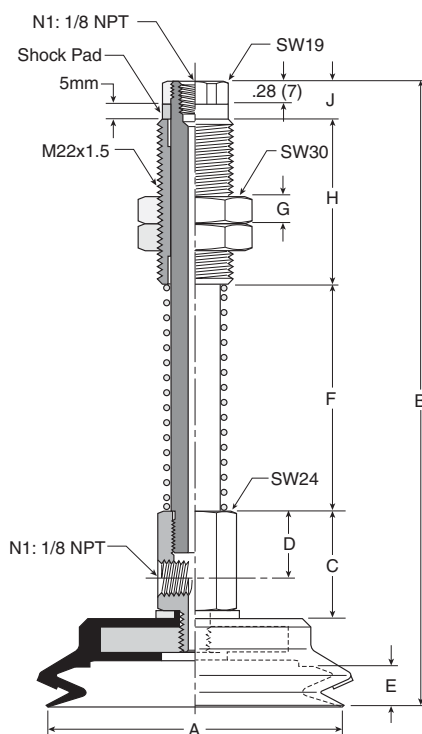

Model number	ØA	B	C	D	E	F	G	H	J	Wt oz (g)
PJTYS6030**†	2.36 (60)	6.18 (157)	1.18 (30)	.79 (20)	.31 (8)	1.18 (45)	.39 (10)	1.97 (50)	.47 (12)	10.4 (294)
PJTYS6050**†	2.36 (60)	7.17 (182)	1.18 (30)	.79 (20)	.31 (8)	2.76 (70)	.39 (10)	1.97 (50)	.47 (12)	11.6 (328)
PJTYS8030**†	3.15 (80)	6.22 (158)	1.18 (30)	.79 (20)	.37 (9.5)	1.18 (45)	.39 (10)	1.97 (50)	.47 (12)	11.9 (338)
PJTYS8050**†	3.15 (80)	7.20 (183)	1.18 (30)	.79 (20)	.37 (9.5)	2.76 (70)	.39 (10)	1.97 (50)	.47 (12)	13.1 (372)

Inches (mm)

** Cup material

† Vacuum port

A
Technical
PFG Flat
PBG Bellows
P5V-CFS Flat
PJG Short Bellows
PCG Multiple Bellows
PIGB Flat Swivel
Cup Fittings

Features

2-1/2 bellows design minimizes contact pressure applied to the product. The soft seal lip and touch allows the cup to conform to the product's surface to make a vacuum seal.

These multiple bellow cups are designed for applications that require additional level compensation, more flexibility, or minimum back pressure for a "soft touch". The multiple bellow has a soft sealing edge good for a variety of sensitive applications; such as food packaging, CD / DVD, medical packaging, and highly irregular curved surfaces. Cups can also be used to assist with sheet separation in destack operations.



Features

- Soft touch
- Extra level compensation
- Flexible sealing lip for irregular curved surfaces
- 5mm to 90mm in diameter

Styles

- PCTM series male thread connector
- PCTF series female thread connector
- PCTK series barbed bulkhead

Specifications

Cup material	Nitrile	Nitrile ESD*	Silicon	Silicon ESD*	Urethane
Material code	NBR	NBRE	SI	SIE	U
Operating temperature (°C)	-20° to +120°	0° to +60°	-60° to +250°	-10° to +130°	-20° to +75°
Color	Black	Black / Blue Dot	White	Black / Red Dot	Blue
Hardness, shore A (°Sh)	55 ±5	70 ±5	55 ±5	55 ±5	55 ±5
Electrical resistance (Ωm)	—	800 to 1000	—	5 to 15	—

* ESD: Electric Static Dissipative Material

How to order

Cups assemblies and replacement cups are specified by cup diameter and material. Standard nitrile and silicon are listed on the following pages. To specify an alternative material, replace the cup material with alternative cup material code.

Example: To specify a cup assembly with urethane (U), replace (NBR) with (U) in the part number. PCTM-20B-NBR-G1 becomes PCTM-20B-U-G1. Inquire with factory for availability.

Application guide

2-1/2 Bellows

Flat surface, any section	Bowed surface, thin section	Slightly bowed surface, any section	Bowed surface, any section	Soft material	Metal sheet handling	Corrugated sheet handling	Differences in heights and levels	Not for vertical lift



PCTM Series Male Thread Connector

Simple male connection for low profile positions secured to a plate or bracket. NPT, G, metric threads.
Fitting material: aluminum.

Installation

Note:

When installing cup assemblies, use a sealant material to secure the assembly and prevent vacuum leakage.

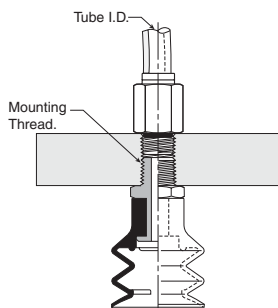

Cup diameter (mm)	Vacuum port	Complete assembly Nitrile (NBR)	Replacement cup Nitrile (NBR)	Complete assembly Silicon (SI)	Replacement cup Silicon (SI)	Replacement cup fitting
5	M5	PCTM-5-NBR-M5	PCG-5-NBR	PCTM-5-SI-M5	PCG-5-SI	FTM-5A-M5H
7	M5	PCTM-7-NBR-M5	PCG-7-NBR	PCTM-7-SI-M5	PCG-7-SI	FTM-5A-M5H
10	M5	PCTM-10-NBR-M5	PCG-10-NBR	PCTM-10-SI-M5	PCG-10-SI	CTM-10-M5H
10	G1	PCTM-10-NBR-G1	PCG-10-NBR	PCTM-10-SI-G1	PCG-10-SI	CTM-10-G1H
15	M5	PCTM-15-NBR-M5	PCG-15-NBR	PCTM-15-SI-M5	PCG-15-SI	CTM-10-M5H
15	G1	PCTM-15-NBR-G1	PCG-15-NBR	PCTM-15-SI-G1	PCG-15-SI	CTM-10-G1H
20	M5	PCTM-20-NBR-M5	PCG-20-NBR	PCTM-20-SI-M5	PCG-20-SI	CTM-10-M5H
20	G1	PCTM-20-NBR-G1	PCG-20-NBR	PCTM-20-SI-G1	PCG-20-SI	CTM-10-G1H
30	G1	PCTM-30-NBR-G1	PCG-30-NBR	PCTM-30-SI-G1	PCG-30-SI	CTM-30-G1H
30	G2	PCTM-30-NBR-G2	PCG-30-NBR	PCTM-30-SI-G2	PCG-30-SI	CTM-30-G2
30	N1	PCTM-30-NBR-N1	PCG-30-NBR	PCTM-30-SI-N1	PCG-30-SI	CTM-30-N1
40	G1	PCTM-40-NBR-G1	PCG-40-NBR	PCTM-40-SI-G1	PCG-40-SI	CTM-30-G1H
40	G2	PCTM-40-NBR-G2	PCG-40-NBR	PCTM-40-SI-G2	PCG-40-SI	CTM-30-G2
40	N1	PCTM-40-NBR-N1	PCG-40-NBR	PCTM-40-SI-N1	PCG-40-SI	CTM-30-N1
60	G1	PCTM-60-NBR-G1	PCG-60-NBR	PCTM-60-SI-G1	PCG-60-SI	CTM-30-G1H
60	N1	PCTM-60-NBR-N1	PCG-60-NBR	PCTM-60-SI-N1	PCG-60-SI	CTM-30-N1
90	G2	PCTM-90-NBR-G2	PCG-90-NBR	PCTM-90-SI-G2	PCG-90-SI	CTM-90-G2
90	N2	PCTM-90-NBR-N2	PCG-90-NBR	PCTM-90-SI-N2	PCG-90-SI	CTM-90-N2

Most popular.



A

Technical

PCG Flat

PBG Bellows

P5V-CFS Flat

PJG Short Bellows

PCG Multiple Bellows

PUGB Flat Swivel

Cup Fittings

PCTF Series Female Thread Connector

Simple female connection for low profile positions secured to a plate or bracket. NPSF, G threads. Fitting material: aluminum.

A

Technical

PCG Flat

PCG Bellows

PCV-CFS Flat

PCG Short Bellows

PCG Multiple Bellows

PCGB Flat Swivel

Cup Fittings

Installation

Note:

When installing cup assemblies, use a sealant material to secure the assembly and prevent vacuum leakage.

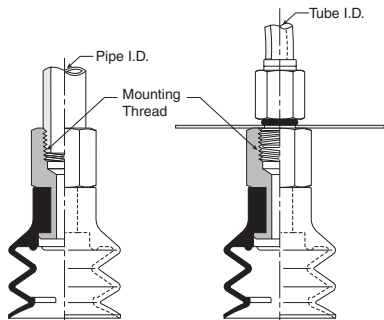

Cup diameter (mm)	Vacuum port	Complete assembly Nitrile (NBR)	Replacement cup Nitrile (NBR)	Complete assembly Silicon (SI)	Replacement cup Silicon (SI)	Replacement cup fitting
5	M5	PCTF-5-NBR-M5	PCG-5-NBR	PCTF-5-SI-M5	PCG-5-SI	FTF-5A-M5
7	M5	PCTF-7-NBR-M5	PCG-7-NBR	PCTF-7-SI-M5	PCG-7-SI	FTF-5A-M5
10	1/8 BSPP	PCTF-10-NBR-G1	PCG-10-NBR	PCTF-10-SI-G1	PCG-10-SI	CTF-10-G1
15	1/8 BSPP	PCTF-15-NBR-G1	PCG-15-NBR	PCTF-15-SI-G1	PCG-15-SI	CTF-10-G1
20	1/8 BSPP	PCTF-20-NBR-G1	PCG-20-NBR	PCTF-20-SI-G1	PCG-20-SI	CTF-10-G1
30	1/8 BSPP	PCTF-30-NBR-G1	PCG-30-NBR	PCTF-30-SI-G1	PCG-30-SI	CTF-30-G1
30	1/8 NPT	PCTF-30-NBR-N1	PCG-30-NBR	PCTF-30-SI-N1	PCG-30-SI	CTF-30-N1
40	1/8 BSPP	PCTF-40-NBR-G1	PCG-40-NBR	PCTF-40-SI-G1	PCG-40-SI	CTF-30-G1
40	1/8 NPT	PCTF-40-NBR-N1	PCG-40-NBR	PCTF-40-SI-N1	PCG-40-SI	CTF-30-N1
60	1/8 NPT	PCTF-60-NBR-N1	PCG-60-NBR	PCTF-60-SI-N1	PCG-60-SI	CTF-30-G1
60	1/4 NPT	PCTF-60-NBR-N1	PCG-60-NBR	PCTF-60-SI-N1	PCG-60-SI	CTF-30-N1
90	1/4 BSPP	PCTF-90-NBR-G2	PCG-90-NBR	PCTF-90-SI-G2	PCG-90-SI	CTF-90-G2
90	1/4 NPT	PCTF-90-NBR-N2	PCG-90-NBR	PCTF-90-SI-N2	PCG-90-SI	CTF-90-N2

Most popular.



PCTK Series Barbed Bulkhead

Top stem connectors secured with jam nuts and allow tubing connections at the top side. Fitting material: nickel plated brass.

Installation

Note:

When installing cup assemblies, use a sealant material to secure the assembly and prevent vacuum leakage.

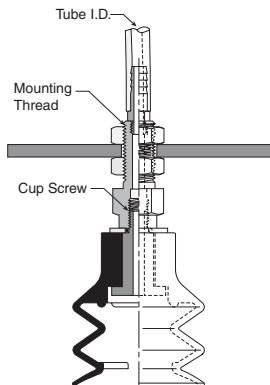

Cup diameter (mm)	Vacuum port	Complete assembly Nitrile (NBR)	Replacement cup Nitrile (NBR)	Complete assembly Silicon (SI)	Replacement cup Silicon (SI)	Replacement cup fitting
5	Barb	PCTK-5-NBR	PCG-5-NBR	PCTK-5-SI	PCG-5-SI	FTK-5A
7	Barb	PCTK-7-NBR	PCG-7-NBR	PCTK-7-SI	PCG-7-SI	FTK-5A
10	Barb	PCTK-10-NBR	PCG-10-NBR	PCTK-10-SI	PCG-10-SI	CTK-10
15	Barb	PCTK-15-NBR	PCG-15-NBR	PCTK-15-SI	PCG-15-SI	CTK-10
20	Barb	PCTK-20-NBR	PCG-20-NBR	PCTK-20-SI	PCG-20-SI	CTK-10
30	Barb	PCTK-30-NBR	PCG-30-NBR	PCTK-30-SI	PCG-30-SI	CTK-30
40	Barb	PCTK-40-NBR	PCG-40-NBR	PCTK-40-SI	PCG-40-SI	CTK-30
60	Barb	PCTK-60-NBR	PCG-60-NBR	PCTK-60-SI	PCG-60-SI	CTK-30
90	NPT	PCTK-90-NBR-N1	PCG-90-NBR	PCTK-90-SI-N1	PCG-90-SI	CTK-90-N1
90	BSPP	PCTK-90-NBR-G1	PCG-90-NBR	PCTK-90-SI-G1	PCG-90-SI	CTK-90-G1

A	Technical
	PCG Flat
PBG Bellows	
P5V-CFS Flat	
PJG Short Bellows	
PCG Multiple Bellows	
PIUGB Flat Swivel	
Cup Fittings	

Most popular.



A
Applications

- Destack perimeter separation
- Level compensation for applications where level compensators do not have adequate space
- Controlling downstroke lifts product on contact

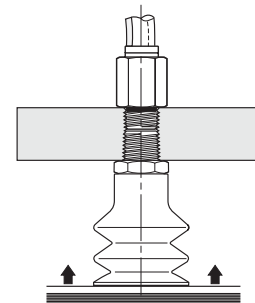
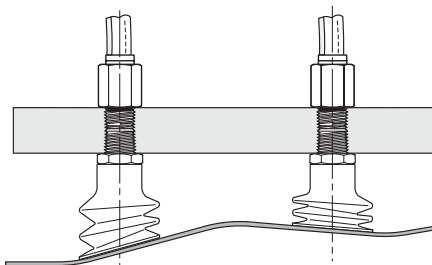
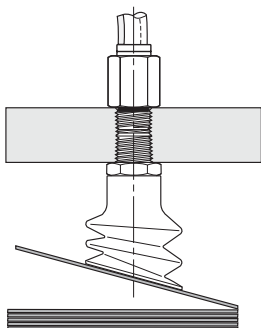
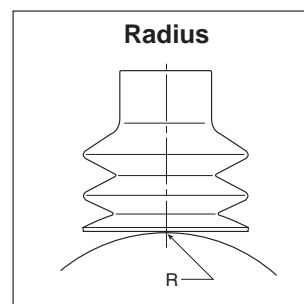
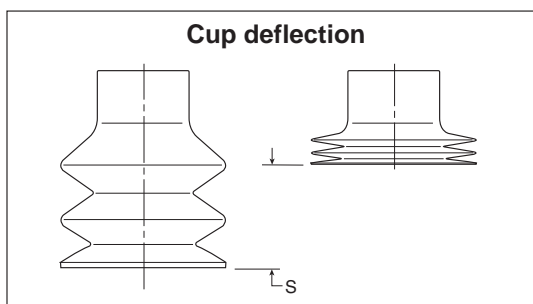
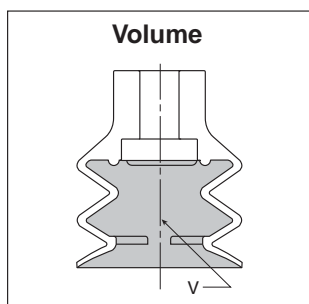

Main data for 2-1/2 bellows PCG cups

Model number	Cup diameter inches (mm)	Area cm ²	Volume (V) liters	Lifting force @ 60% (N)		Cup deflection (S) (mm)	Radius (R) (mm)
				⊕↑	⊖↑		
PCG-5-*	.20 (5)	.20	.00003	1.20	—	3	3.5
PCG-7-*	.28 (7)	.39	.00004	2.40	—	3	4.0
PCG-10-*	.39 (10)	.79	.0001	4.80	—	3	5.0
PCG-15-*	.59 (15)	1.77	.0009	10.8	—	10	6.0
PCG-20-*	.79 (20)	3.14	.002	19.2	—	10	8.0
PCG-30-*	1.18 (30)	7.07	.009	43.2	—	14.5	20.0
PCG-40-*	1.57 (40)	12.6	.018	76.9	—	22	30.0
PCG-60-*	2.36 (60)	28.3	.072	173	—	27	55.0
PCG-90-*	3.54 (90)	63.6	.1639	389	—	42	80.0

* Cup material

PCG Series Replacement Cup Dimensions

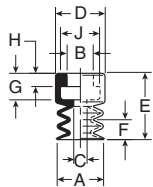
**PCG-5 and
PCG-7**



**PCG-10 thru
PCG-20**

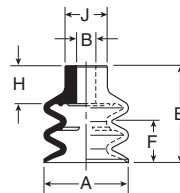

**PCG-30 thru
PCG-60**

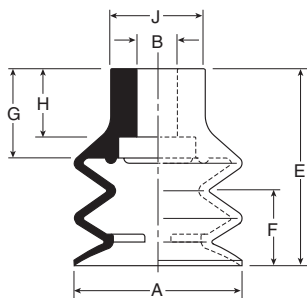

PCG-90

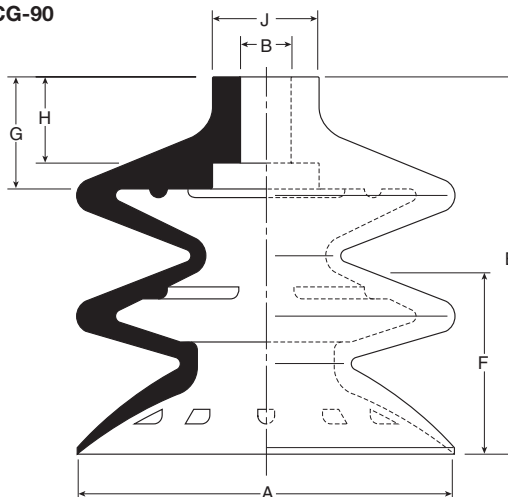

A

Technical

PCG Flat

PBG Bellows

P5V-CFS Flat

PJG Short Bellows

PCG Multiple Bellows

PUGB Flat Swivel

Cup Fittings

Model number	ØA	ØB	ØC	ØD	E	F	G	H	J
PCG-5-*	.20 (5)	.16 (4)	.08 (2)	.30 (7.5)	.37 (9.5)	.12 (3)	.16 (4)	.08 (2)	.24 (6)
PCG-7-*	.28 (7)	.16 (4)	.08 (2)	.30 (7.5)	.39 (10)	.12 (3)	.16 (4)	.08 (2)	.24 (6)
PCG-10-*	.35 (9)	.20 (5)	—	—	.59 (15)	.12 (3)	.28 (7)	—	.35 (9)
PCG-15-*	.60 (15.2)	.20 (5)	—	—	.90 (22)	.39 (10)	.35 (9)	—	.39 (10)
PCG-20-*	.79 (20)	.20 (5)	—	—	.91 (23)	.39 (10)	.35 (9)	—	.39 (10)
PCG-30-*	1.26 (32)	.31 (8)	—	—	1.48 (37.5)	.57 (14.5)	.67 (17)	.51 (13)	.71 (18)
PCG-40-*	1.65 (42)	.31 (8)	—	—	1.81 (46)	.87 (22)	.67 (17)	.51 (13)	.79 (20)
PCG-60-*	2.44 (62)	.31 (8)	—	—	2.17 (55)	1.06 (27)	.71 (18)	.51 (13)	.85 (21.5)
PCG-90-*	3.46 (88)	.47 (12)	—	—	3.44 (87.5)	1.65 (42)	1.02 (26)	.79 (20)	.98 (25)

Inches (mm)
* Cup material



- A
- Technical
- PFG Flat
- PBG Bellows
- P5V-CFS Flat
- PUG Short Bellows
- PCG Multiple Bellows
- PUGB Flat Swivel
- Cup Fittings

Dimensions

PCTM-5 and PCTM-7

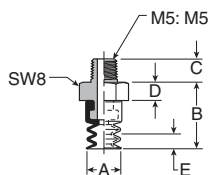

PCTM-10 thru PCTM-20

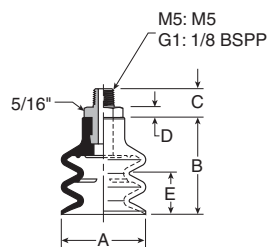

PCTM-30 thru PCTM-60

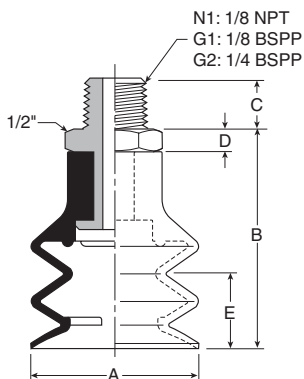

PCTM-90

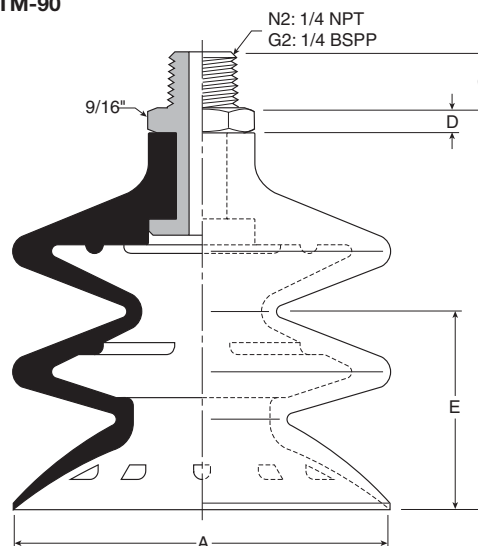

Model number	ØA	B	C (M5)	C (N1 / G1)	C M10 / G2)	C (N2)	D	E
PCTM-5- [*] †	.20 (5)	.51 (13)	.18 (4.5)	—	—	—	.14 (3.5)	.12 (3)
PCTM-7- [*] †	.28 (7)	.53 (13.5)	.18 (4.5)	—	—	—	.14 (3.5)	.12 (3)
PCTM-10- [*] †	.35 (9)	.69 (17.5)	.18 (4.5)	.31 (8)	—	—	.10 (2.5)	.12 (3)
PCTM-15- [*] †	.60 (15.2)	1.04 (25.5)	.18 (4.5)	.31 (8)	—	—	.10 (2.5)	.39 (10)
PCTM-20- [*] †	.79 (20)	1.04 (25.5)	.18 (4.5)	.31 (8)	—	—	.10 (2.5)	.39 (10)
PCTM-30- [*] †	1.26 (32)	1.67 (42.5)	—	.31 (8)	.39 (10)	—	.20 (5)	.57 (14.5)
PCTM-40- [*] †	1.65 (42)	2.01 (51)	—	.31 (8)	.39 (10)	—	.20 (5)	.87 (22)
PCTM-60- [*] †	2.44 (62)	2.36 (60)	—	.31 (8)	.39 (10)	—	.20 (5)	1.06 (27)
PCTM-90- [*] †	3.46 (88)	3.64 (92.5)	—	—	.39 (10)	.59 (15)	.20 (5)	1.65 (42)

Inches (mm)
^{*} Cup material
[†] Thread size



Dimensions

**PCTF-5 and
PCTF-7**

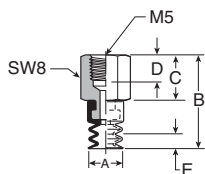

**PCTF-10 thru
PCTF-20**

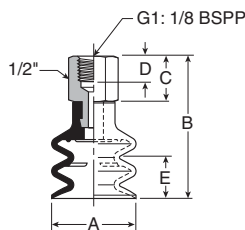

**PCTF-30 thru
PCTF-60**

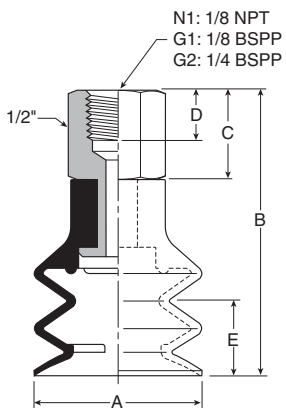

PCTF-90

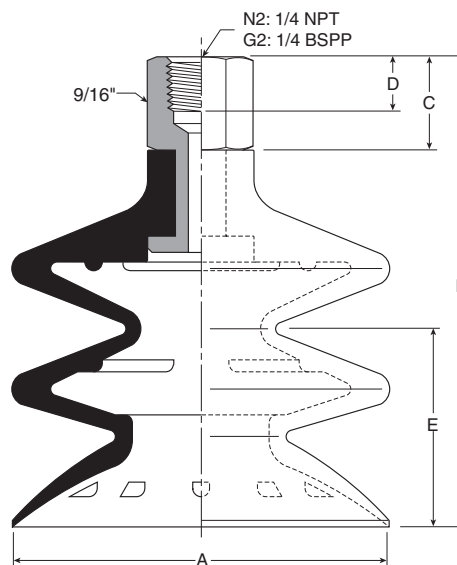

A

Technical

PFG
Flat

PBG
Bellows

P5V-CFS
Flat

PJG Short
Bellows

PCG
Multiple
Bellows

PUGB
Flat Swivel

Cup
Fittings

Model number	ØA	B	C	D	E
PCTF-5*†	.20 (5)	.85 (21.5)	.47 (12)	.31 (8)	.12 (3)
PCTF-7*†	.28 (7)	.87 (22)	.47 (12)	.31 (8)	.12 (3)
PCTF-10*†	.35 (9)	1.06 (27)	.47 (12)	.31 (8)	.12 (3)
PCTF-15*†	.60 (15.2)	1.38 (35)	.47 (12)	.31 (8)	.39 (10)
PCTF-20*†	.79 (20)	1.38 (35)	.47 (12)	.31 (8)	.39 (10)
PCTF-30*†	1.26 (32)	2.03 (51.5)	.55 (14)	.31 (8)	.57 (14.5)
PCTF-40*†	1.65 (42)	2.36 (60)	.55 (14)	.31 (8)	.87 (22)
PCTF-60*†	2.44 (62)	2.72 (69)	.55 (14)	.31 (8)	1.06 (27)
PCTF-90*†	3.46 (88)	4.13 (105)	.69 (17.5)	.39 (10)	1.65 (42)

Inches (mm)
* Cup material
† Thread size



- A**
- Technical
- PFG Flat
- PBG Bellows
- P5V-CFS Flat
- PUG Short Bellows
- PCG Multiple Bellows
- PUGB Flat Swivel
- Cup Fittings

Dimensions

PCTK-5 and PCTK-7

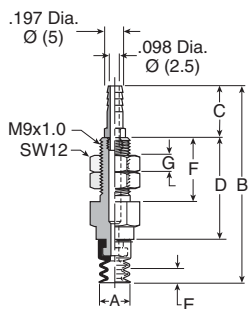

PCTK-10 thru PCTK-20

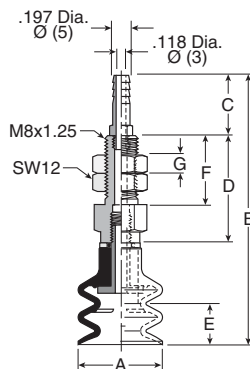

PCTK-30 thru PCTK-60

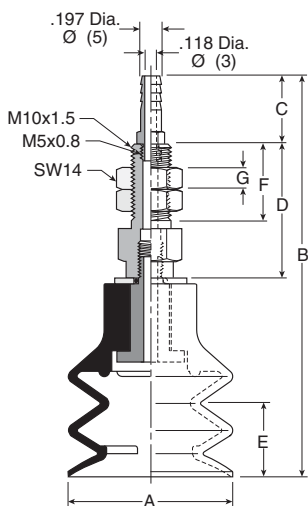

PCTK-90

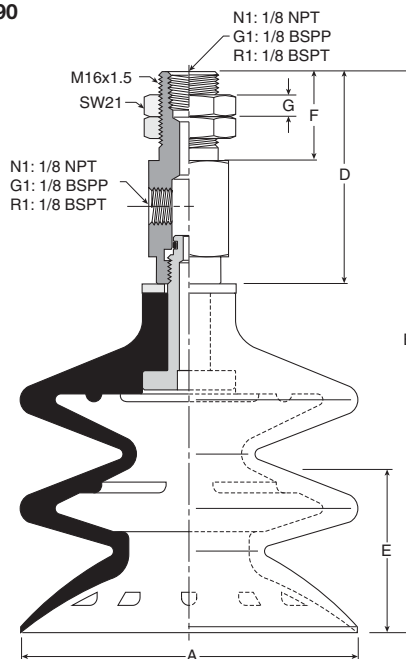

Model number	ØA	B	C	D	E	F	G	Wt oz. (g)
PCTK-5-*	.20 (5)	1.32 (33.5)	.39 (10)	.55 (14)	.12 (3)	.47 (12)	.12 (3)	.56 (11)
PCTK-7-*	.28 (7)	1.34 (34)	.39 (10)	.55 (14)	.12 (3)	.47 (12)	.12 (3)	.56 (11)
PCTK-10-*	.35 (9)	2.21 (56.2)	.63 (16)	.88 (22.5)	.12 (3)	.59 (15)	.16 (4)	.78 (22)
PCTK-15-*	.60 (15.2)	2.53 (64.2)	.63 (16)	.86 (22)	.39 (10)	.59 (15)	.16 (4)	.78 (22)
PCTK-20-*	.79 (20)	2.53 (64.2)	.63 (16)	.86 (22)	.39 (10)	.59 (15)	.16 (4)	.78 (22)
PCTK-30-*	1.26 (32)	3.42 (86.8)	.63 (16)	1.26 (32)	.57 (14.5)	.79 (20)	.20 (5)	1.62 (46)
PCTK-40-*	1.65 (42)	3.75 (95.3)	.63 (16)	1.26 (32)	.86 (22)	.79 (20)	.20 (5)	1.94 (55)
PCTK-60-*	2.44 (62)	4.11 (104.3)	.63 (16)	1.26 (32)	1.06 (27)	.79 (20)	.20 (5)	3.00 (85)
PCYK-90-*	3.46 (88)	5.70 (144.8)	.91 (23)	2.17 (55)	1.65 (42)	.43 (11)	—	10.58 (300)

Inches (mm)
 * Cup material
 † Vacuum port



Vacuum Cups PUGB Flat Swivel Vacuum Cups

Features

30° inclusive swivel, single lip cup for smooth, slightly curved surfaces and flexible products. Rigid construction provides good stability against acceleration and deceleration forces during product transfer.

The single edge swivel cup is for smooth surfaces with slightly curved surfaces or flexible sheets with substantial weights. Typically, lift capacities and break away forces are higher for flat cups which may be necessary for good stability during lift and transfer. The position of the internal swivel joint minimizes moments during lift and transfer. The swivel joint compensates for load and angular misalignment instead of the cup material, prolonging cup life. Maintenance costs are minimized by replacing only the cup portion of the assembly.



Features

- Internal swivel joint design
- 30° Inclusive angle for flexible products
- Increased stability for horizontal lifts
- Lower maintenance costs
- 60mm to 100mm diameters

Styles

- PUTK series barbed bulkhead
- PUTYS series bulkhead level compensator

Specifications

Suction cup material	Nitrile (NBR)	Silicon (SI)
Operating temperature (°C)	-20° to +120°	-60° to +250°
Color	Black	White
Hardness, shore A (°Sh)	55 ±5	55 ±5

Application guide

Swivel Bellows

Flat surface, thin section	Flat surface, any section	Slightly bowed surface, thin section	Slightly bowed surface, any section	Metal sheet handling	Not for vertical lift

A

Technical

PFG Flat

PBG Bellows

P5V-CFS Flat

PJG Short Bellows

PCG Multiple Bellows

PUGB Flat Swivel

Cup Fittings

PUTK Series Barbed Bulkhead

Top stem connectors secured with jam nuts and allow tubing connections at the top side. Fitting material: nickel plated brass.

Installation
Note:

When installing cup assemblies, use a sealant material to secure the assembly and prevent vacuum leakage.

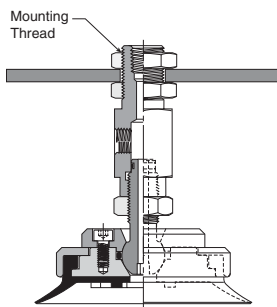

Cup size	Vacum port	Cup material Nitrile assembly (NBR)	Replacement PUGB swivel with cup only	Replacement cup only (NBR)	Cup fitting
60	1/8 NPT	PUTK-60-NBR-N1	PUGB-60-NBR	PUG-60-NBR	UTK-60-N1
80	1/8 NPT	PUTK-80-NBR-N1	PUGB-80-NBR	PUG-80-NBR	UTK-60-N1
100	1/8 NPT	PUTK-100-NBR-N1	PUGB-100-NBR	PUG-100-NBR	UTK-60-N1

PUTYS Series Bulkhead Level Compensator

303 stainless steel construction secured with jam nuts. Spring biased compensators can absorb impacts of down-strokes and adjust for different levels of pick up points. 303 stainless corrosion resistant materials with drymet bushings increases the strength and life.

Installation
Note:

When installing cup assemblies, use a sealant material to secure the assembly and prevent vacuum leakage. Shown are interchangeable connectors & plugs for port connections.

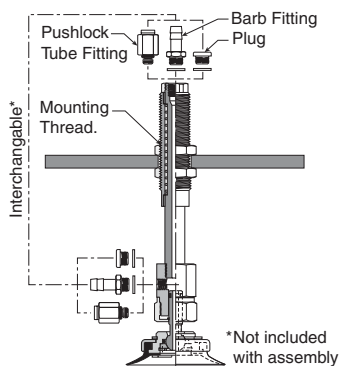

Cup diameter (mm)	Vacum port	Stroke (mm)	Spring compression Force lbf (N)		PUTYS assembly (NBR)	Replacement PUGB swivel with cup only	Replacement cup only NBR	Level compensator P/N
			0%	100%				
60	1/8 NPT	30	1.6 (6.8)	3.6 (15.6)	PUTYS6030NBRN1	PUGB-60-NBR	PUG-60-NBR	UTYS-60-30
60	1/8 NPT	50	1.9 (8.3)	4.5 (19.6)	PUTYS6050NBRN1	PUGB-60-NBR	PUG-60-NBR	UTYS-60-50
80	1/8 NPT	30	1.6 (6.8)	3.6 (15.6)	PUTYS8030NBRN1	PUGB-80-NBR	PUG-80-NBR	UTYS-60-30
80	1/8 NPT	50	1.9 (8.3)	4.5 (19.6)	PUTYS8050NBRN1	PUGB-80-NBR	PUG-80-NBR	UTYS-60-50
100	1/8 NPT	30	1.6 (6.8)	3.6 (15.6)	PUTYS10030NBRN1	PUGB-100-NBR	PUG-100-NBR	UTYS-60-30
100	1/8 NPT	50	1.9 (8.3)	4.5 (19.6)	PUTYS10050NBRN1	PUGB-100-NBR	PUG-100-NBR	UTYS-60-50

Most popular.



Applications

- Angles pickup

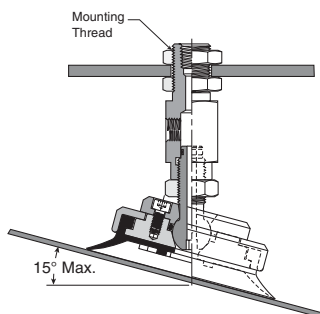

- Fixtures for curved product

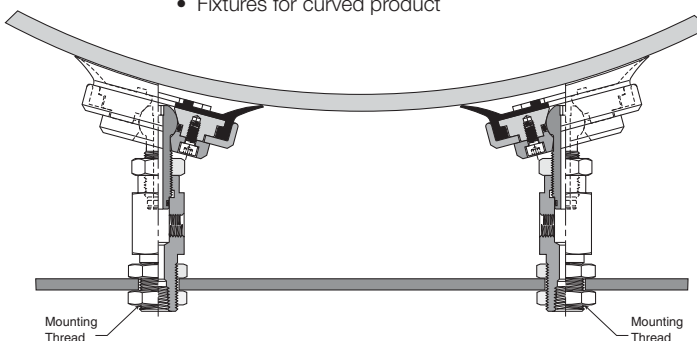

Main data for swivel bellows PUG cups

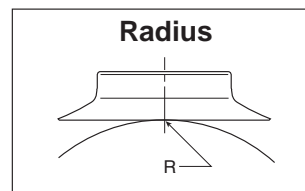
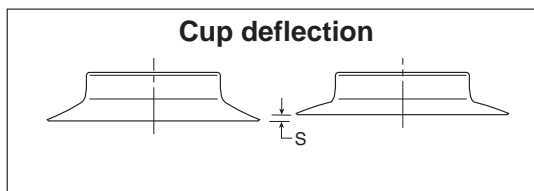
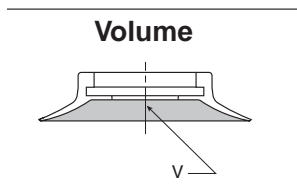

Model number	Cup diameter inches (mm)	Area cm ²	Volume (V) liters	Lifting force @ 60% (N)		Cup deflection (S) mm	Radius R (mm)
PUGB-60-*	2.36 (60)	28.3	0.0090	173	—	5	70
PUGB-80-*	3.15(80)	50.3	0.025	308	—	6	100
PUGB-100-*	3.94 (100)	78.5	0.045	480	—	6	150

* Cup material

A
Technical
PFG Flat
PBG Bellows
P5V-CFS Flat
PJG Short Bellows
PCG Multiple Bellows
PUGB Flat Swivel
Cup Fittings

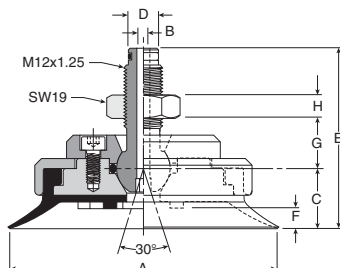
PUGB Series Barbed Bulkhead Dimensions
**PUGB-60 thru
PUGB-100**

Model number	ØA	ØB	C	ØD	E	F	G	H
PUGB-60-*	2.36 (60)	.15 (3.9)	.63 (16)	.35 (9)	2.05 (52)	.20 (5)	.59 (15)	.28 (7)
PUGB-80-*	3.15 (80)	.15 (3.9)	.71 (18)	.35 (9)	2.13 (54)	.24 (6)	.59 (15)	.28 (7)
PUGB-100-*	3.94 (100)	.15 (3.9)	.71 (18)	.35 (9)	2.13 (54)	.24 (6)	.59 (15)	.28 (7)

 Inches (mm)
 * Cup material

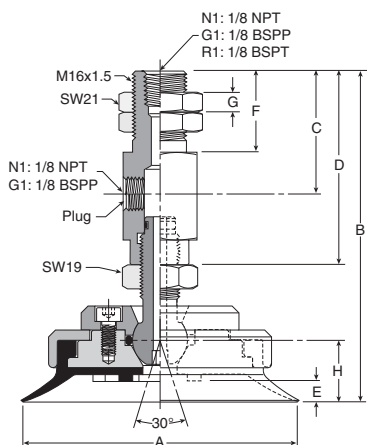
PUTK Series Barbed Bulkhead Dimensions
**PUTK-60 thru
PUTK-100**

Model number	ØA	B	C	D	E	F	G	H	Wt oz (g)
PUTK-60-*	2.36 (60)	3.66 (93)	.63 (16)	1.89 (48)	.20 (5)	.91 (23)	.24 (6)	.63 (16)	12.4 (352)
PUTK-80-*	3.15 (80)	3.74 (95)	1.38 (35)	2.16 (55)	.24 (6)	.91 (23)	.24 (6)	.71 (18)	15.7 (444)
PUTK-100-*	3.94 (100)	3.74 (95)	1.38 (35)	2.16 (55)	.24 (6)	.91 (23)	.24 (6)	.71 (18)	20.0 (568)

 Inches (mm)
 * Cup material

A60

Parker Hannifin Corporation
 Pneumatic Division
 Richland, Michigan
www.parker.com/pneumatics

Dimensions

**PUTYS60 thru
 PUTYS100**

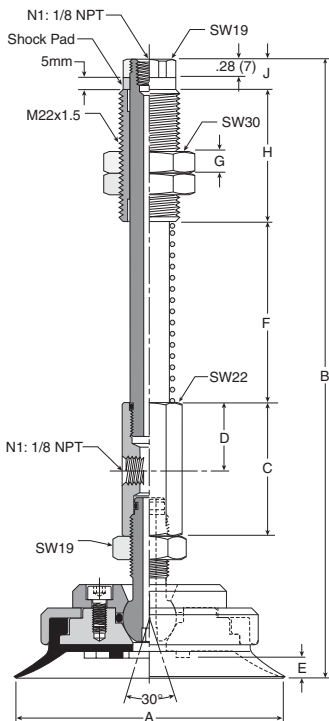

Model number	ØA	B	C	D	E	F	G	H	J	Wt oz (g)
PUTYS6030*	2.36 (60)	7.28 (185)	1.57 (40)	.79 (20)	.20 (5)	1.77 (45)	.39 (10)	1.97 (50)	.47 (12)	17.2 (487)
PUTYS6050*	2.36 (60)	8.27 (210)	1.57 (40)	.79 (20)	.20 (5)	2.76 (70)	.39 (10)	1.97 (50)	.47 (12)	18.4 (521)
PUTYS8030*	3.15 (80)	7.36 (187)	1.57 (40)	.79 (20)	.24 (6)	1.77 (45)	.39 (10)	1.97 (50)	.47 (12)	19.7 (559)
PUTYS8050*	3.15 (80)	8.35 (212)	1.57 (40)	.79 (20)	.24 (6)	2.76 (70)	.39 (10)	1.97 (50)	.47 (12)	20.1 (595)
PUTYS10030*	1.18 (30)	7.36 (187)	1.57 (40)	.79 (20)	.24 (6)	1.77 (45)	.39 (10)	1.97 (50)	.47 (12)	25.7 (729)
PUTYS10050*	1.18 (30)	8.35 (212)	1.57 (40)	.79 (20)	.24 (6)	2.76 (70)	.39 (10)	1.97 (50)	.47 (12)	26.7 (756)

Inches (mm)
 * Cup material

A
Technical
PFG Flat
PBG Bellows
P5V-CFS Flat
PJG Short Bellows
PCG Multiple Bellows
PUGB Flat Swivel
Cup Fittings

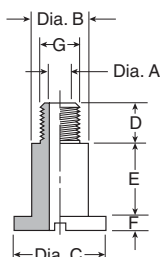

Cup screws
A

Part number	A	B	C	D	E	F	G
TN-PF-15-M5	.10 (2.5)	.20 (5)	.31 (8)	.22 (5.5)	.06 (1.5)	(2)	M5
TN-PF-20-M5	.10 (2.5)	.20 (5)	.43 (11)	.24 (6)	.12 (3)	(2)	M5
TN-PF-25-M6	.14 (3.5)	.33 (8.5)	.55 (14)	.24 (6)	.43 (11)	(2)	M6
TN-PF-50-M6	.14 (3.5)	.31 (8)	.79 (20)	.24 (6)	.24 (6)	(2)	M6
TN-PF-50-M8	.16 (4)	.31 (8)	.79 (20)	.39 (10)	.20 (5)	(2)	M8
TN-PF-10-M5	.10 (2.5)	.12 (3)	.24 (6)	.22 (5.5)	.08 (2)	(2)	M5
TN-PF-30-M6	.13 (3.4)	.31 (8)	.59 (15)	.41 (10.5)	.41 (10.5)	(3)	M6
TN-PC-30-M8	.15 (3.9)	.31 (8)	.29 (15)	.47 (12)	.39 (10)	(3)	M8
TN-PC-90-M12	.15 (3.9)	.47 (12)	.98 (25)	.43 (11)	.75 (19)	(5)	M12

Inches (mm)



Male threaded cup fittings

	Cup fitting	Cup series	Cup assembly	Vacuum port
	FTM-5A-M5H	PFG / PBG / PJG / PCG	PFTM / PBTM / PJTM / PCTM	M5
	FTM-5A-G1	PFG / PBG / PJG / PCG	PFTM / PBTM / PJTM / PCTM	1/8 BSPP
	FTM-20B-G1H	PFG / PBG / PJG	PFTM / PBTM / PJTM	1/8 BSPP
	FTM-20B-N1	PFG / PBG / PJG	PFTM / PBTM / PJTM	1/8 NPT
	FTM-20B-G2	PFG / PBG / PJG	PFTM / PBTM / PJTM	1/8 BSPP
	FTM-20B-M10	PFG / PBG / PJG	PFTM / PBTM / PJTM	M10
	FTM-50-N1	PFG / PBG / PJG	PFTM / PBTM / PJTM	1/8 NPT
	FTM-50-G1H	PFG / PBG / PJG	PFTM / PBTM / PJTM	1/8 BSPP
	FTM-60-N2	PFG / PBG / PJG	PFTM / PBTM / PJTM	1/4 NPT
	FTM-60-G2	PFG / PBG / PJG	PFTM / PBTM / PJTM	1/8 BSPP
	FTM-60-M10	PFG / PBG / PJG	PFTM / PBTM / PJTM	M10
	CTM-10-M5H	PCG	PCTM	M5
	CTM-10-N1	PCG	PCTM	1/8 NPT
	CTM-10-G1H	PCG	PCTM	1/8 BSPP

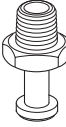
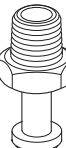
Male threaded cup fittings

	Cup fitting	Cup series	Cup assembly	Vacuum port
	CTM-30-N1	PCG	PCTM	1/8 NPT
	CTM-30-G1H	PCG	PCTM	1/8 BSPP
	CTM-30-G2	PCG	PCTM	1/8 BSPP
	CTM-90-N2	PCG	PCTM	1/4 NPT
	CTM-90-G2	PCG	PCTM	1/8 BSPP

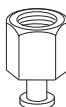
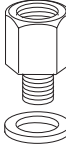
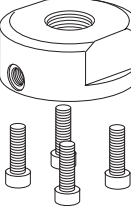
Female threaded cup fittings

	Cup fitting	Cup series	Cup assembly	Vacuum port
	FTF-5A-M5	PFG / PBG / PJG	PFTF / PBTF / PJTF	M5
	FTF-5A-G1	PFG / PBG / PJG	PFTF / PBTF / PJTF	1/8 BSPP
	FTF-20B-G1	PFG / PBG / PJG	PFTF / PBTF / PJTF	1/8 BSPP
	FTF-20B-G2	PFG / PBG / PJG	PFTF / PBTF / PJTF	1/8 BSPP
	FTF-50-G1	PFG / PBG / PJG	PFTF / PBTF / PJTF	1/8 BSPP
	FTF-50-G2	PFG / PBG / PJG	PFTF / PBTF / PJTF	1/8 BSPP
		FTF-60-N2	PFG / PBG / PJG	PFTF / PBTF / PJTF
FTF-60-G2		PFG / PBG / PJG	PFTF / PBTF / PJTF	1/8 BSPP
	FTF-120-N4	PFG / PBG	PFTF / PBTF	1/2 NPT
	FTF-120-G4	PFG / PBG	PFTF / PBTF	1/2 BSPP
	CTF-10-G1	PCG	PCTF	1/8 BSPP

A

Technical

 PFG
Flat

 PBG
Bellows

 P5V-CFS
Flat

 PJG Short
Bellows

 PCG
Multiple
Bellows

 PUGB
Flat Swivel

 Cup
Fittings

		Female threaded cup fittings			
		Cup fitting	Cup series	Cup assembly	Vacuum port
A		CTF-30-N1	PCG	PCTF	1/8 NPT
		CTF-30-G1	PCG	PCTF	1/8 BSPP
Technical		CTF-90-N2	PCG	PCTF	1/4 NPT
PFG Flat		CTF-90-G2	PCG	PCTF	1/8 BSPP
PBG Bellows	Bulkhead cup fittings				
P5V-CFS Flat		FTK-5A	PFG / PBG / PJG / PCG / PAG	PFTK / PBTK / PJTK / PCTK / PATK	Barb Fitting
PJG Short Bellows		FTK-15	PFG / PBG / PJG	PFTK / PBTK / PJTK	Barb Fitting
PCG Multiple Bellows		FTK-20	PFG / PFOG / PBG / PJG	PFTK / PBTK / PJTK	Barb Fitting
		FTK-25	PFG / PFOG / PBG / PJG / PAG	PFTK / PBTK / PJTK / PATK	Barb Fitting
PUGB Flat Swivel		FTK-50	PFG / PBG / PJG	PFTK / PBTK / PJTK	Barb Fitting
Cup Fittings		FTK-60-N1	PFG / PBG / PJG	PFTK / PBTK / PJTK	1/8 NPT
	FTK-60-G1	PFG / PBG / PJG	PFTK / PBTK / PJTK	1/8 BSPP	
		CTK-10	PCG	PCTK	Barb Fitting
		CTK-30	PCG	PCTK	Barb Fitting
		UTK-20	PUGB	PUTK	Barb Fitting
		UTK-40			

Bulkhead cup fittings

	Cup fitting	Cup series	Cup assembly	Vacuum port
	UTK-60-N1	PUGB	PUTK	1/8 NPT
	UTK-60-G1	PUGB	PUTK	1/8 BSPP
	UTK-60-R1	PUGB	PUTK	1/8 BSPT

90° cup fittings

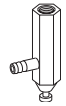
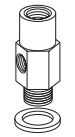
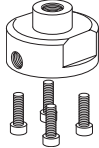
	Cup fitting	Cup series	Cup assembly	Vacuum port
	FYK-5A	PFG / PBG / PJG / PCG	PFYK / PBYK / PJYK / PCYK	Barb Fitting
	FYK-15	PFG / PBG / PJG	PFYK / PBYK / PJYK	Barb Fitting
FYK-20	PFG / PBG / PJG	PFYK / PBYK / PJYK		
FYK-25	PFG / PBG / PJG	PFYK / PBYK / PJYK		
FYK-50	PFG / PBG / PJG	PFYK / PBYK / PJYK		
	FYK-60-N1	PFG / PBG / PJG	PFYK / PBYK / PJYK	1/8 NPT
	FYK-60-G1			
	FYK-120-N1	PFG / PBG	PFYK / PBYK	1/8 NPT
	FYK-120-G1			

Level compensators

	Assembly part number	Cup series	Cup assembly	Compensator only	Cup fitting
	TYS-2A-3	PFG / PBG / PJG	PFTYS / PBTYS / PJTYS	TYS-M5-3-M5	FTY-2A-M5-M3
	TYS-2A-15			TYS-M5-15-M5	
	TYS-5A-10	PFG / PBG	PFTYS / PBTYS	TYS-M5-10-M5	FTY-5A-M5-M5
	TYS-5A-15			TYS-M5-15-M5	
	TYS-20B-15	PFG / PBG / PJG	PFTYS / PBTYS / PJTYS	TYS-M8-15-M5	FTY-20B-M8-M5
	TYS-20B-30			TYS-M8-30-M5	
	TYS-50-15	PFG / PBG / PJG	PFTYS / PBTYS / PJTYS	TYS-M8-15-M5	FTY-50
	TYS-50-30			TYS-M8-30-M5	



A65

Parker Hannifin Corporation
 Pneumatic Division
 Richland, Michigan
www.parker.com/pneumatics
A

Technical

 PFG
Flat

 PBG
Bellows

 P5V-CFS
Flat

 PJG Short
Bellows

 PCG
Multiple
Bellows

 PUGB
Flat Swivel

 Cup
Fittings

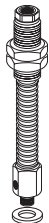
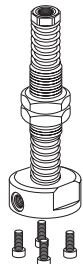
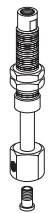
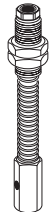
		Level compensators					
		Assembly part number	Cup series	Cup assembly	Compensator only	Cup fitting	
A	Technical		TYS-60-30			TYS-M14-25-N	
			—————	PFG / PBG / PJG	PFTYS / PBTYS / PJTYS	—————	FTY-60/95
	PFg Flat		TYS-60-50			TYS-M14-45-N	
	PBG Bellows		TYS-120-20	PFg / PBG	PFTYS / PBTYS	TYS110/200M1820	FTY-120-N2
	PSV-CFS Flat		TYS-120-70	PFg / PBG	PFTYS / PBTYS	TYS110/200M1870	FTY-120-N2
	PJG Short Bellows		JTYS-10-10			NAPJYS-10-10-K	
	PCG Multiple Bellows		—————	PJG	PJTYS	—————	TN-PF-15-M5
	PUGB Flat Swivel		JTYS-10-15			NAPJYS-10-15-K	
	Cup Fittings		UTYS-60-30			TYS-M14-25-N	
			—————	PUGB	PUTYS	—————	UTY-60-M14-N1
			UTYS-60-50				TYS-M14-45-N



Vacuum Generators

Section B

www.parker.com/pneu/vacgen

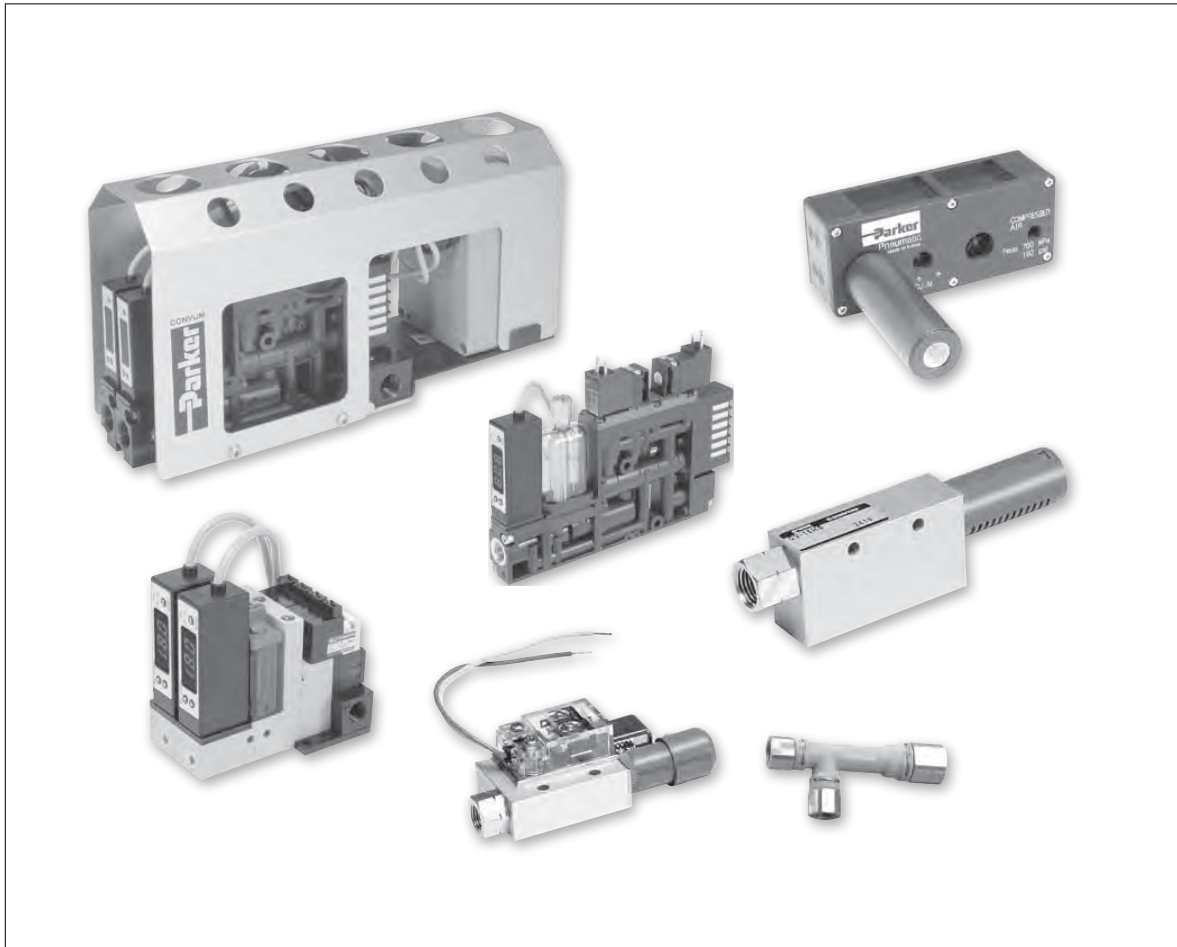

B

Generator Selection

MCA, CV, CV-GK

CHF

MC22

MC72

CEK

CVXCEK

MPS-23

MVS-201

Generator Accessories

Glossary



B1

Parker Hannifin Corporation
Pneumatic Division
Richland, Michigan
www.parker.com/pneumatics

B

Generator
Selection

MCA, CV,
CV-CK

CHF

MC22

MC72

CEK

CVXCIEK







MPS-23

MVS-201

Generator
Accessories

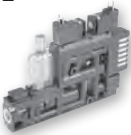
Glossary



Generator Selection	How to Select a Generator	B4 - B9							
Inline Vacuum Generators: Single Stage									
MCA, CV, CV-CK 	<p>MCA is lightweight generator that can be located directly on the cup fitting for space savings. Great for use with TYS level compensators.</p> <p>CV is a basic Venturi Generator with aluminum basic body. Includes exhaust muffler.</p> <p>CV-CK is a Venturi Generator with adjustable open contact mechanical switch for vacuum confirmation. Great for low cost vacuum confirmation.</p> <p>Additional Pneumatic Control Valve is required to create vacuum flow with these products.</p>	B10 - B11							
Inline Vacuum Generators: Multi Stage									
CHF 	<p>CHF- High Flow Series is a multistage vacuum generator. CHF unit is intended for high flow vacuum applications that due to system porosity issues have a low application degree of vacuum. These units are ideal for porous applications. 4 bolt mounting pattern with gauge opposite of vacuum and pressure inlet ports enables this generator to be panel mounted. CHF Series comes standard with flow thru exhaust mufflers to reduce clogging in dirty environments. Additional Pneumatic Control Valve is required to create vacuum flow.</p>	B12 - B13							
Integrated Vacuum Generators									
MC22 	<p>The MC22 has integrated vacuum generating and blow-off release pilot valves to minimize the response time to achieve vacuum. The small foot print and lightweight body allows the unit to be located close to the suction cup for maximum performance. The MC22 has additional features; regulating blow-off needle, 37 micron mesh filter, The MC22 can be assembled into a maximum 8 station manifold. The unit can be ordered normally open or normally closed and with or without. Integrated check valves offer air economizing options with the MPS-23 and MVS-201 pressure sensors.</p>	B14 - B19							
MC72 	<p>The MC72 is perfect for non-porous applications such as material handling, critical applications involving glass, or general transfer applications. The MC72 has integrated vacuum pilot and blow-off release pilot valves to minimize response times. The MC72 has additional features; regulating blow-off needle, 130 micron filter, optional check valve. The MC72 can be assembled into a maximum 5 station manifold. The unit can be ordered normally open or normally closed. Integrated check valves offer air economizing options with the MPS-23 and MVS-201 pressure sensors.</p>	B20 - B25							
CEK 	<p>CEK Venturi Generator is a basic vacuum blow off integrated generator with the addition of a memory valve that maintains the last state of air during an emergency stop or power loss. The CEK Generator integrated components include valves for vacuum, air economizing, and blow-off functions, blow-off flow regulating valve, vacuum filters and a vacuum check valve. Optional pressure sensors reduce cycle time and can be used for air economizing to conserve air during part transfer. Inline versions can be mounted in manifolds up to 5 stations.</p>	B26 - B31							
CVXCEK 	<p>CVXCEK Venturi Generator is a basic 2 station CEK Generator Manifold with the addition of Emergency Stop Functions that maintains the last state of air during an emergency stop or power loss. This unit can be used for high-speed pick and place and material handling systems. CVXCEK Generator integrated components include valves for vacuum and blow-off functions, blow-off flow regulating valve, exhaust , vacuum filters and an optional vacuum check valve. Air economizing can be utilized with the vacuum check valve to conserve air during part transfer. No additional PLC programming is required for Air Economizing Functions because this function is built into the electrical unit.</p>	B32 - B39							
Generator Mount Sensors									
MPS23 	<table border="1"> <tr> <td>-101.3 - 0 kPa -14.5 to 0 PSI</td> <td>(2) NPN / PNP</td> <td>Air, Non-corrosive gas</td> <td>IP40</td> <td>Variable, 100% F.S.</td> <td>Push button</td> <td>LED display (Red)</td> </tr> </table>	-101.3 - 0 kPa -14.5 to 0 PSI	(2) NPN / PNP	Air, Non-corrosive gas	IP40	Variable, 100% F.S.	Push button	LED display (Red)	B40 - B43
-101.3 - 0 kPa -14.5 to 0 PSI	(2) NPN / PNP	Air, Non-corrosive gas	IP40	Variable, 100% F.S.	Push button	LED display (Red)			
MVS201 	<table border="1"> <tr> <td>0 to -30 inHg -14.7 to 72.5 PSI</td> <td>(1) NPN / PNP</td> <td>Air, Non-corrosive gas</td> <td>IP40</td> <td>Variable, 100% F.S.</td> <td>Push button</td> <td>LED display (Red)</td> </tr> </table>	0 to -30 inHg -14.7 to 72.5 PSI	(1) NPN / PNP	Air, Non-corrosive gas	IP40	Variable, 100% F.S.	Push button	LED display (Red)	B44 - B49
0 to -30 inHg -14.7 to 72.5 PSI	(1) NPN / PNP	Air, Non-corrosive gas	IP40	Variable, 100% F.S.	Push button	LED display (Red)			
Generator Accessories	Filters, Check Valves, Silencers	B50 - B57							
Glossary		B58 - B59							

B
Generator Selection
MCA, CV, CV-CK
CHF
MC22
MC72
CEK
CVXCEK
MPS-23
MVS-201
Generator Accessories
Glossary



Principle of venturi vacuum

A vacuum generator is a single stage venturi that creates high vacuum with fast response using compressed air.

The ability to control this performance renders this technology as an excellent solution for factory automation.

In principle, compressed air is throttled as the air exits the nozzle and is discharged into the diffuser. This increased velocity of air lowers the pressure in the diffusion chamber. The volume of air within the closed vacuum system flows into the low pressure area of the diffusion chamber and is exhausted thru the diffuser. This effect increases the vacuum level and evacuates most of the air within the closed vacuum system at supersonic speeds.

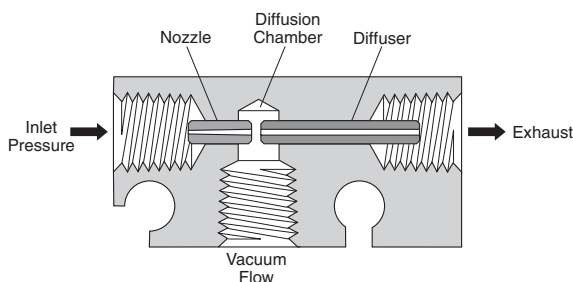

Additional advantages to venturi generators

- No moving components
- Low maintenance
- Long life
- Responsive
- Physically small
- Cost effective

Applying the venturi generator

1. Design a system with basic venturi generators and individual components to support the vacuum circuit.

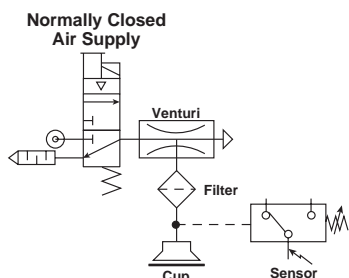

2. Design a system with all of the supporting components integrated into the venturi generator.

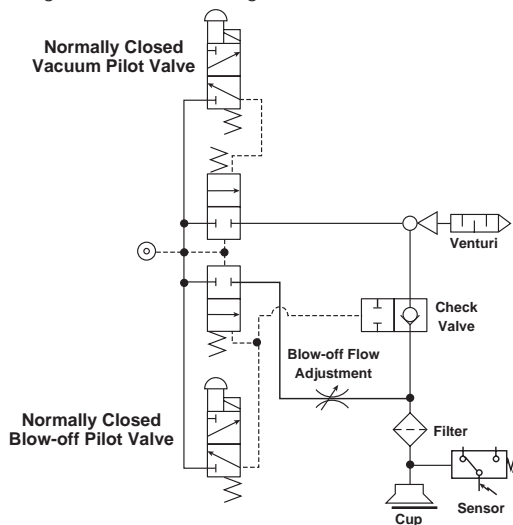

There are several advantages to an integrated venturi system. The response time of the vacuum and blow-off functions are greatly reduced compared to basic venturi generators, the installation time is also reduced which makes this a cost effective system and the compact size allows the integrated unit to be close to the suction cup.

Venturi generator with power loss circuits

When designing a vacuum system that requires a Normally Open circuit or Emergency Stop circuits to avoid any hazard during a power failure, consider the circuits below and on the following page.

Normally open circuit

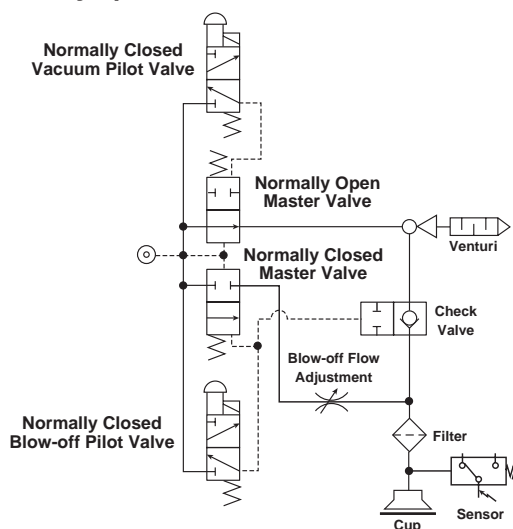

B
Generator Selection
MCA, CV, CV-CK
CHF
MC22
MC72
CEK
CVXCEK
MPS-23
MWS-201
Generator Accessories
Glossary



Valve controlled emergency stop circuit
 (See CEK Vacuum Generator)

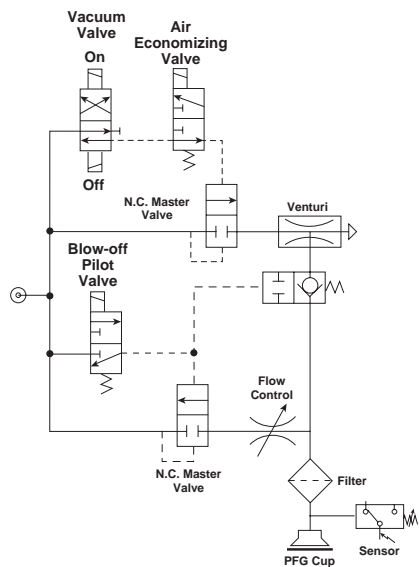

The venturi system

A closed vacuum system has a volume of air within all the components between the vacuum port of the venturi and the suction cup. The venturi's ability to evacuate this volume of air when the suction cup forms a seal on the surface, creates the pressure differential required to force the suction cup onto the product.

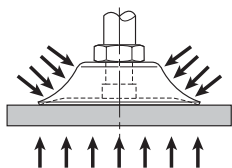

The evacuated air creates a lower air pressure within the closed vacuum system, causing the atmospheric pressure to apply a uniform force on the surface of the cup. This holding force is proportional to the difference in pressures and area of the suction cup.

Selecting the appropriate supply valve

If a basic venturi generator is selected, correct sizing of the air supply valve and supply line are critical to the performance of the unit.

Nozzle Diameter	Minimum Tube I.D. inches (mm)	Flow (Cv)
0.5 mm	0.157 (4)	0.16
1.0 mm	0.157 (4)	0.16
1.5 mm	0.236 (6)	0.379
2.0 mm	0.315 (8)	0.65
2.5 mm	0.315 (8)	0.95
3.0 mm	0.393 (10)	1.35

If pressure drops occur due to other pneumatic components or a manifold venturi system, it may be necessary to increase the valve and / or supply line tubing I.D..

Selecting the nozzle diameter with reference to suction cup diameter

As a general guide, for most non-porous vacuum applications, the nozzle diameter can be selected based on the suction cup diameter previously determined in Section A.

Nozzle diameter	Maximum suction cup diameter Inches (mm)
0.5 mm	.79 (20)
1.0 mm	1.97 (50)
1.5 mm	2.36 (60)
2.0 mm	4.72 (120)
2.5 mm	5.91 (150)
3.0 mm	7.87 (200)

Designing a system with a single suction cup dedicated to a single vacuum generator is ideal, however, it may not always be practical. It is recommended that the sum of the areas of multiple cups dedicated to a single venturi do not exceed the area of the diameter of the single suction cups shown above.

B
Generator Selection
MCA, CV, CV-GK
CHF
MC22
MC72
CEK
CVXCEK
MPS-23
MVS-201
Generator Accessories
Glossary

Selecting a generator size

The choice of Generator Series depends on the system requirements for components and overall performance for the application. Inline Generators offer the basic function for creating vacuum flow. Adding integrated components such as automatic blow off Controls, Vacuum and Blow-off Solenoids, Pressure Sensors, Check Valves and Filters are options that can reduce overall mounting space, reduce cycle time and can offer air conservation functions as well as emergency stop modes. For guidelines on selecting Vacuum Generators by features, consult the highlight features in the Generator Index section for each Series Section.

A vacuum source can only achieve and hold a degree of vacuum that sustains the amount of leakage into the vacuum system. In most cases, it is the leakage through the product and by of the cup seal that limits the system degree of vacuum. Products with high product leakage are Porous Applications. The degree of vacuum that can be obtained with this type of product can vary and tends to be below 10 inHg. Products with low or no leakage are called Non-Porous Applications. It can be assumed that the maximum degree of vacuum of the system is the maximum degree of the vacuum generator. Due to design cycle time and safety requirements, a lower degree of vacuum is generally chosen other than the maximum obtainable degree of vacuum. Chart 1 lists different units of measure for vacuum with typical application levels. The system degree of vacuum must be determined by product testing.

Evacuation time

The size of the generator generally refers to either the Evacuation Time or the Vacuum Flow Rates of the generator and varies by the size of the nozzle / diffuser.

Evacuation Time is the time required to evacuate the air out of a vacuum system to specific degree of vacuum. Typically, this degree of vacuum is a value where it is safe to move a product in a pick and place application and is determined by the design engineer. Evacuation Time can also be considered response time of the system.

A typical Evacuation Time chart for a generator series is shown in Chart 2. The time to achieve a given degree of vacuum in a 1 cubic foot volume is listed in seconds for each Generator.

Example: A pick and place application requires a 0.25 secs

Chart 2: evacuation time

Series / nozzle diameter	Air supply pressure PSI	Air consumption SCFM	Evacuation time in sec / ft ³ * to reach different vacuum levels (inHg)								
			3	6	9	12	15	18	21	24	27
CV-05HS	70	0.46	24.3	57.3	101.0	160.5	231.1	305.1	433.1	597.7	—
CV-05LS	70	0.46	11.0	23.4	40.0	64.4	110.2	—	—	—	—
CV-10HS	70	1.55	4.8	9.9	16.0	24.9	35.9	51.4	77.4	117.5	226.0
CV-10LS	70	1.55	3.7	7.6	13.0	20.3	33.1	—	—	—	—
CV-15HS	70	3.53	2.5	4.8	7.0	11.0	15.5	22.0	31.9	46.6	112.1
CV-15LS	70	3.53	2.0	3.1	5.0	7.6	12.1	—	—	—	—
CV-20HS	70	6.36	1.7	2.8	5.0	6.5	9.0	13.0	18.9	27.4	60.7
CV-20LS	70	6.36	1.3	2.5	4.0	5.9	11.3	—	—	—	—

* 1 ft³ = 28.31 liters

Chart 1: Basic vacuum pressure measurements units

Negative gauge pressure PSIG	Absolute pressure PSIA	Inches of mercury inHg
0	14.7	0
Atmospheric pressure at sea level		
-1.5	13.2	3
-3.0	11.7	6
-4.5	10.2	9
Typical porous vacuum level		
-6.0	8.7	12
-7.5	7.2	15
-9.0	5.7	18
-10.5	4.2	21
Typical non-porous vacuum level		
-12.0	2.7	24
-13.5	1.2	27
-14.7	0	29.92
Perfect vacuum (zero reference pressure)		

for creation of 18 inHg of vacuum in the vacuum system. The vacuum system volume, which includes tubing and cups, is 0.002 ft³.

The evacuation time charts are given for a 1 cubic foot (ft³) volume. To use these charts, convert the time requirement of the system to an equivalent time for a 1 cubic foot (ft³) volume. In this example, 1 cubic foot (ft³) is 500 times the system volume of 0.002 ft³. Multiply the system time requirement by 500 (500 x 0.25 secs = 125 seconds). Any generator with an evacuation time of less than 125 seconds to attain 18 inHg can be chosen for this application. A CV-15-HS will meet the requirements for this application. A (-) listed means the generator will not obtain a higher degree of vacuum than the level of the first (-).

B

Generator Selection

MCA, CV, CV-CK

CHF

MC22

MC72

CEK

CVXCIEK

MPS-23

MWS-201

Generator Accessories

Glossary



Vacuum flow

A typical Vacuum Flow chart for a generator series is listed in Chart 3. The vacuum flow rate at given degree of vacuum is listed in SCFM for each Generator. This chart is generally used to determine the change of degree of vacuum given a change in vacuum flow rate of a generator.

Example. A CV-15HS can only obtain 9 inHg. The vacuum flow rate at 9 inHg is 1.50 SCFM. This means that the cup seal and

product leaks 1.50 SCFM of air. This generator can maintain the leak rate of 1.50 SCFM. Choosing a generator with more flow at 9 inHg will increase the degree of vacuum in the system because the generator can overcome more leakage. In this case, the vacuum flow rates are linear since this CV generator is a single stage venturi generator. Replacing a CV-15HS with CV-20HS will increase the degree of vacuum in the system to approximately 16.2 inHg. The CV-20HS now maintains 16.2 inHg at a flow rate of 1.50 SCFM.

Chart 3: Vacuum flow (SCFM)

Nozzle diameter	inHg										
	0	3	6	9	12	15	18	21	24	27	30
CV-05HS	.21	.19	.17	.15	.13	.11	.09	.07	.05	.03	—
CV-05LS	.32	.27	.22	.17	.12	.06	—	—	—	—	—
CV-10HS	.95	.85	.75	.65	.55	.45	.35	.25	.15	.05	—
CV-10LS	1.27	1.05	.83	.59	.38	.17	—	—	—	—	—
CV-15HS	2.22	1.98	1.74	1.5	1.26	1.01	.76	.51	.25	.10	—
CV-15LS	3.35	2.79	2.23	1.67	1.10	.53	—	—	—	—	—
CV-20HS	3.88	3.45	3.02	2.59	2.16	1.73	1.30	.87	.44	.25	—
CV-20LS	5.85	5.09	4.03	2.97	1.91	.85	—	—	—	—	—

Tubing reference

Tubing ID		Tubing length (L)	
SAE	mm	In.	M
5/64	2	18	.457
3/32	2.38	24	.610
1/8	3.17	30	.762
5/32	4	36	.914
3/16	4.76	42	1.07
1/4	6.35	48	1.22
5/16	8	54	1.37
3/8	9.52	60	1.52
7/16	11.1	66	1.67

SAE x 25.4 = mm In. x 25.4 = M

Pad volume reference (p_v)

PFG			PBG			PCG		
Ø	Cu in.	L	Ø	Cu in.	L	Ø	Cu in.	L
2	.00004	.0000006	10	.013	.0002	5	.002	.00003
3.5	.0001	.000002	15	.045	.0007	7	.003	.00004
5	.0003	.000005	20	.070	.001	10	.010	.0001
6	.00048	.000008	30	.28	.004	15	.060	.0009
8	.002	.00003	40	.56	.009	18	.082	.001
10	.004	.00007	50	1.60	.026	20	.123	.002
15	.012	.0002	75	4.63	.076	30	.595	.009
20	.03	.0005	110	6.77	.111	40	1.15	.018
25	.067	.0011	150	15.86	.26	60	4.40	.072
30	.067	.0011				90	10.00	.1639
35	.14	.0023						
40	.18	.003						
50	.25	.0042						
60	.57	.0094						
80	1.28	.021						
95	1.95	.032						
110	5.00	.082						
150	10.80	.177						
200	23.24	.381						

1 ft³ = 28.31 liters
1 ft³ = 1728 in³

Nozzle diameter to tubing diameter to cup diameter reference

For each application, the size of the nozzle diameter, vacuum tubing I.D., and maximum cup diameter must be practical in relationship to each other. The chart to the right is a quick reference to aid in selecting the vacuum tubing I.D. and nozzle diameter given the maximum cup diameter.

As an example, one 60mm cup with 2 meters in tubing length would require a minimum 6mm I.D. vacuum tube and a 1.5mm nozzle. The same 60mm cup with 3.5 meters in tubing length would require a minimum 8mm I.D. vacuum tube and a 2.0mm nozzle to achieve an equivalent performance.

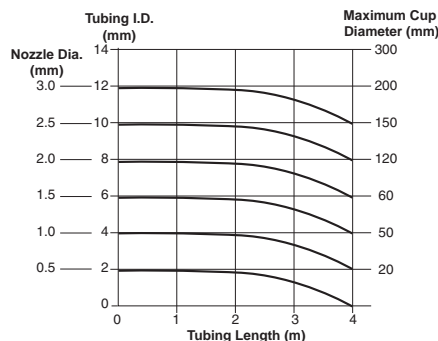

B

Generator Selection

MCA, CV, CV-GK

CHF

MC22

MC72

CEK

CVXCEK

MPS-23

MVS-201

Generator Accessories

Glossary

Evacuation time

Series / Nozzle diameter	Air supply pressure PSI	Air consumption SCFM	Evacuation time in sec / ft ³ * to reach different vacuum levels (inHg)								
			3	6	9	12	15	18	21	24	27
MCA10HS	70	1.68	5.1	11.0	18.0	28.2	41.0	58.2	83.1	123.2	—
MCA13HS	70	2.81	3.7	7.3	12.0	19.5	28.5	39.8	58.5	104.2	—
CV05HS	70	0.46	24.3	57.3	101.0	160.5	231.1	305.1	433.1	597.7	—
CV05LS	70	0.46	11.0	23.4	40.0	64.4	110.2	—	—	—	—
CV10HS	70	1.55	4.8	9.9	16.0	24.9	35.9	51.4	77.4	117.5	226.0
CV10LS	70	1.55	3.7	7.6	13.0	20.3	33.1	—	—	—	—
CV15HS	70	3.53	2.5	4.8	7.0	11.0	15.5	22.0	31.9	46.6	112.1
CV15LS	70	3.53	2.0	3.1	5.0	7.6	12.1	—	—	—	—
CV20HS	70	6.36	1.7	2.8	5.0	6.5	9.0	13.0	18.9	27.4	60.7
CV20LS	70	6.36	1.3	2.5	4.0	5.9	11.3	—	—	—	—
CV25HS	70	9.36	1.4	2.3	3.0	4.5	6.5	9.0	13.0	18.9	35.3
CV25LS	70	9.36	1.0	2.0	3.0	3.7	5.6	—	—	—	—
CV30AHS	70	13.60	1.1	2.0	2.8	3.5	4.8	6.8	9.6	16.7	29.1
CV30ALS	70	13.60	0.9	1.5	2.7	3.4	5.1	—	—	—	—
CV10HSCK	70	1.55	4.8	9.9	16.0	24.9	35.9	51.4	77.4	117.5	226.0
CV15HSCK	70	3.53	2.5	4.8	7.0	11.0	15.5	22.0	31.9	46.6	112.1
CV20HSCK	70	6.36	0.7	2.8	5.0	6.5	9.0	13.0	18.9	27.4	60.7
CHF20	80	6.5	0.21	0.64	1.70	4.03	7.63	11.65	19.28	33.48	94.50
CHF30	80	9.6	0.21	0.63	1.27	3.39	6.36	9.53	16.10	27.76	78.82
CHF40	80	14.0	0.17	0.42	1.27	2.33	4.03	5.93	9.75	16.95	47.67

 * 1 ft³ = 28.31 liters

Vacuum flow (SCFM)

Nozzle diameter	nHg										
	0	3	6	9	12	15	18	21	24	27	30
MCA10HS	.88	.78	.68	.58	.47	.37	.26	.16	.06	—	—
MCA13HS	1.26	1.11	.96	.81	.67	.53	.39	.25	.11	—	—
CV05HS	.21	.19	.17	.15	.13	.11	.09	.07	.05	.03	—
CV05LS	.32	.27	.22	.17	.12	.06	—	—	—	—	—
CV10HS	.95	.85	.75	.65	.55	.45	.35	.25	.15	.05	—
CV10LS	1.27	1.05	.83	.59	.38	.17	—	—	—	—	—
CV15HS	2.22	1.98	1.74	1.50	1.26	1.01	.76	.51	.26	.10	—
CV15LS	3.35	2.79	2.23	1.67	1.10	.53	—	—	—	—	—
CV20HS	3.88	3.45	3.02	2.59	2.16	1.73	1.30	.87	.44	.25	—
CV20LS	5.85	5.09	4.03	2.97	1.91	.85	—	—	—	—	—
CV25HS	5.65	5.11	4.57	4.03	3.49	2.94	2.39	1.85	1.31	.77	—
CV25LS	8.83	7.29	5.75	4.21	2.67	1.13	—	—	—	—	—
CV30AHS	7.94	7.16	6.38	5.62	4.84	4.06	3.28	2.50	1.17	.92	—
CV30ALS	12.36	10.24	8.12	6.00	3.89	1.48	—	—	—	—	—
CV10HSCK	.95	.85	.75	.65	.55	.45	.35	.25	.15	.05	—
CV15HSCK	2.22	1.98	1.74	1.5	1.26	1.01	.76	.51	.25	.10	—
CV20HSCK	3.88	3.45	3.02	2.59	2.16	1.73	1.30	.87	.44	.25	—
CHF20	20.90	12.12	7.88	3.85	2.76	2.12	1.45	0.81	0.35	0.04	—
CHF30	26.30	15.27	9.89	4.84	3.46	2.68	1.83	1.02	0.42	0.05	—
CHF40	31.80	18.50	12.00	5.90	4.20	3.30	2.30	1.30	0.60	0.06	—



Evacuation time

Series / Nozzle diameter	Air supply pressure PSI	Air consumption SCFM	Evacuation time in sec / ft ³ to reach different vacuum levels (inHg)								
			3	6	9	12	15	18	21	24	27
MC22S10HS	70	1.55	5.4	12.1	20.0	32.2	52.0	85.0	120.1	183.9	—
MC72S15HS	70	3.53	2.59	5.39	8.99	13.89	20.66	29.36	45.16	69.6	208.23
MC72S20HS	70	6.36	1.13	2.6	5.21	7.91	12.56	19.26	30.84	54.65	129.9
MC72S25HS	70	10.42	0.66	2.19	3.29	6.14	9.3	14.55	23.21	46.13	—
CEK15HS	70	3.53	2.3	4.8	8.0	12.4	18.4	26.3	40.4	62.1	189.3
CEK20HS	70	6.36	1.1	2.5	5.0	7.6	12.1	18.6	29.9	53.4	129.9
CEK27HS	70	10.42	0.6	2.0	3.0	5.6	8.5	13.3	21.2	42.1	—
CVXCEK	70	10.42	0.6	2.0	3.0	5.6	8.5	13.3	21.2	42.1	—

 * 1 ft³ = 28.31 liters

Vacuum flow (SCFM)

Nozzle diameter	nHg										
	0	3	6	9	12	15	18	21	24	27	30
MC22S10HS	.71	.64	.57	.49	.42	.34	.25	.17	.10	—	—
MC72S15HS	2.2	1.96	1.71	1.47	1.22	0.99	0.75	0.51	0.27	—	—
MC72S20HS	3.67	3.21	2.81	2.4	2.04	1.64	1.24	0.84	0.44	—	—
MC72S25HS	5.2	4.61	4.01	3.41	2.82	2.22	1.63	1.04	0.46	—	—
CEK15HS	2.51	2.23	1.95	1.67	1.39	1.12	.85	.58	.30	—	—
CEK20HS	3.75	3.34	2.93	2.50	2.12	1.70	1.28	.86	.44	—	—
CEK27HS	5.75	5.09	4.43	3.77	3.11	2.45	1.80	1.15	.50	—	—
CVXCEK	5.75	5.09	4.43	3.77	3.11	2.45	1.80	1.15	.50	—	—

B

Generator Selection

MCA, CV, CV-GK

CHF

MC22

MC72

CEK

CVXCEK

MPS-23

MVS-201

Generator Accessories

Glossary



Features & Characteristics
MCA, CV, CV-CK

Parker Inline Single Stage Vacuum Generators is a compact design offering multiple vacuum flow ranges in 3 styles. These Generators are meant to be mounted near the vacuum application for improved vacuum response time. A Normally Open or Normally Closed 3 way valve can be used to control the supply pressure to obtain up to a 27 InHg degree of vacuum.

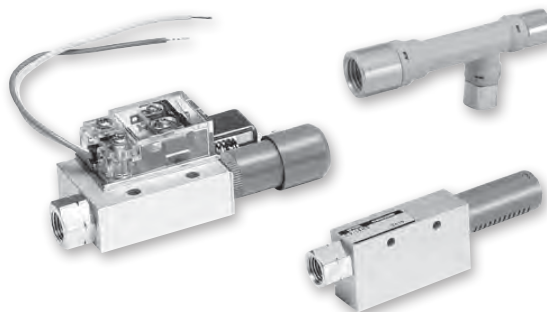
Features

- **MCA:**
 - light weight vacuum generator
 - vacuum flow rates to 1.26 SCFM
- **CV:**
 - basic aluminum body generator with exhaust muffler
 - vacuum flow rates to 12.36 SCFM
 - degree of vacuum to 27 inHg
- **CV-CK**
 - basic aluminum body generator with mechanical vacuum switch
 - vacuum flow rates to 5.85 SCFM
 - degree of vacuum to 27 inHg

Specifications

Media	Non-lubricated air, non-corrosive gases
Operating pressure	14 to 114 PSI
Operating temperature	32° to 120°F (MCA, CV); 32 to 140°F (CV-CK)
Material	Polycarbonate, Aluminum fittings (MCA) Body: Aluminum (CV, CV-CK) Nozzle: Nickel plated brass (CV, CV-CK)
CV-CK Switch	Setting range: 5.9 to 15.7 inHg, accuracy ± 1.57 inHg Hysteresis: 1.1 to 3.9 inHg Switch output: N.O., AC125V; 5A, AC250V: 3A, DC250V: 0.2A

Model numbers

Symbol	Port size			Max. vacuum flow SCFM	Air consumption SCFM	Max. degree of vacuum inHg	Part number	
	Pressure	Vacuum	Exhaust				NPT	BSP
MCA Series								
	1/8	1/8	1/4	1.68	1.68	24	MCA10HSN1N1N2	MCA10HSG1G1N2
	1/8	1/8	1/4	2.81	2.81	24	MCA13HSN1N1N2	MCA13HSG1G1G2
CV Series								
	1/8	1/8	Muffler	0.21	0.46	27	CV05HSN	CV05HSG
	1/8	1/8	Muffler	0.32	0.46	17	CV05LSN	CV05LSG
	1/8	1/8	Muffler	0.95	1.55	27	CV10HSN	CV10HSG
	1/8	1/8	Muffler	1.27	1.55	17	CV10LSN	CV10LSG
	1/4	1/4	Muffler	2.22	3.53	27	CV15HSN	CV15HSG
	1/4	1/4	Muffler	3.35	3.53	17	CV15LSN	CV15LSG
	1/4	3/8	Muffler	3.88	6.36	27	CV20HSN	CV20HSG
	1/4	3/8	Muffler	5.85	6.36	17	CV20LSN	CV20LSG
	3/8	1/2	Muffler	5.65	9.36	27	CV25HSN	CV25HSG
	3/8	1/2	Muffler	8.83	9.36	17	CV25LSN	CV25LSG
CV-CK Series								
	1/8	1/8	—	0.95	1.55	27	CV10HSCKN	CV10HSCKG
	1/4	1/4	—	2.22	3.53	27	CV15HSCKN	CV15HSCKG
	1/4	3/8	—	3.88	6.36	27	CV20HSCKN	CV20HSCKG

☐ Most popular.



Dimensions

MCA

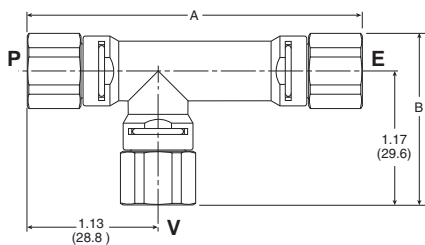

MCA Mounting bracket: MCA-B

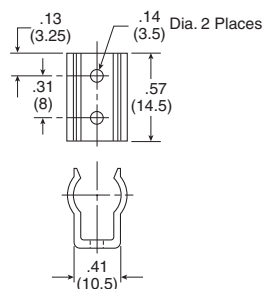

MCA****N1N1N2

Item	A	B
MCA10HS*****	2.76 (70)	1.16 (29.5)
MCA13HS*****	2.76 (70)	1.16 (29.5)

Inches (mm)

CV

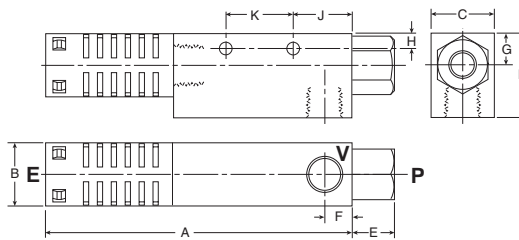

Item	A	B	C	D	E	F	G	H	J	K
CV05HS/LS	3.19 (81)	.73 (18.5)	.63 (16)	1.30 (33)	.39 (10)	.31 (8)	.39 (10)	.18 (4.5)	.55 (14)	.79 (20)
CV10HS/LS	3.19 (81)	.73 (18.5)	.63 (16)	1.30 (33)	.39 (10)	.31 (8)	.39 (10)	.18 (4.5)	.55 (14)	.79 (20)
CV15HS/LS	4.27 (108.5)	.79 (20)	.79 (20)	1.38 (35)	.59 (15)	.39 (10)	.43 (11)	.20 (5)	.79 (20)	.98 (25)
CV20HS/LS	5.73 (145.5)	1.18 (30)	1.18 (30)	1.57 (40)	.79 (20)	.51 (13)	.59 (15)	.28 (7)	1.10 (28)	1.26 (32)
CV25HS/LS	7.72 (196)	1.57 (40)	1.57 (40)	2.36 (60)	.67 (17)	.63 (16)	.79 (20)	.22 (5.5)	.79 (20)	1.97 (50)
CV30AHS/ALS	8.43 (214)	1.57 (40)	1.57 (40)	2.36 (60)	.79 (20)	.79 (20)	.79 (20)	.22 (5.5)	1.30 (33)	1.97 (50)

Inches (mm)

CV-CK

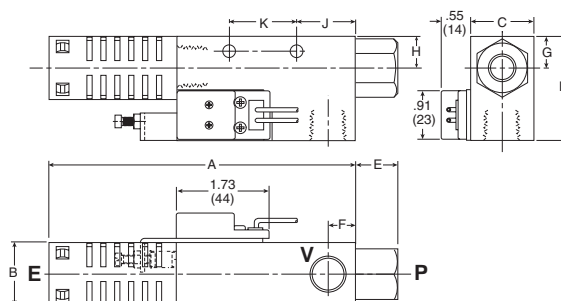

Item	A	B	C	D	E	F	G	H	J	K
CV10HS/LSCK	3.19 (81)	.73 (18.5)	.63 (16)	1.30 (33)	.39 (10)	.31 (8)	.39 (10)	.18 (4.5)	17 (4.2)	.79 (20)
CV15HS/LSCK	4.27 (108.5)	.79 (20)	.79 (20)	1.38 (35)	.59 (15)	.39 (10)	.43 (11)	.20 (5)	.18 (4.5)	.98 (25)
CV20HS/LSCK	5.73 (145.5)	1.18 (30)	1.18 (30)	1.57 (40)	.79 (20)	.51 (13)	.59 (15)	.28 (7)	.24 (6)	1.26 (32)

Inches (mm)

B
Generator Selection
MCA, CV, CV-CK
CHF
MC22
MC72
CEK
CVXCEK
MPS-23
MVS-201
Generator Accessories
Glossary



Features & Characteristics
Vacuum Generators
CHF High Flow Vacuum Generators

CHF - High Flow Series is a multistage vacuum generator. CHF unit is ideal for porous applications.

4 bolt mounting pattern with gauge opposite of vacuum and pressure inlet ports enables this generator to be panel mounted.

CHF Series comes standard with flow thru exhaust mufflers to reduce clogging in dirty environments. Additional Pneumatic Control Valve is required to create vacuum flow.

B

Generator Selection

MCA, CV, CV-CK

CHF

MC22

MC72

CEK

CVXCEK

MFS-23

MWS-201

Generator Accessories

Glossary

Features

- Classic multi-stage venturi
- Anodized aluminum body
- Aluminum body includes exhaust muffler
- Maximum vacuum level, 27.3 inHg
- Vacuum flow rates from 12.5 to 31.8 SCFM
- Mounting brackets included

Specifications

Media	Non-lubricated air, non-corrosive gases
Operating pressure	80 PSI
Operating temperature	32°F to 120°F
Material	Body: Aluminum Nozzle & Diffuser: Polymer Seals: BUNA N

Model numbers

Symbol	Port size			Max. vacuum flow SCFM	Air consumption SCFM	Max. degree of vacuum inHg	Part number NPT
	Pressure	Vacuum	Exhaust				
	1/4	3/8	Muffler	20.9	6.5	27	CHF-20ZNE
	1/4	3/8	Muffler	26.3	9.6	27	CHF-30ZNE
	1/4	3/8	Muffler	31.8	14.0	27	CHF-40ZNE

Accessories

Port size	Description	Part number
3/8	Filter with 10 micron element	VFP2CFC01
1/2		VFP3CFC01
3/8	Filter with 10 micron element and 2 replacement elements	VFP2CFC03
1/2		VFP3CFC03

See Accessories Section for more options

VFP Series filter

Replacement components

Description	Part number
CHF- Repair kit	SFCHF90NN
0 to 30 inHg gauge	266298A
Bracket kit (Includes 4 brackets & 4 M5 x 15 screws)	SFBW15
Silencer (flow thru)	SIS-001

Most popular.



Dimensions

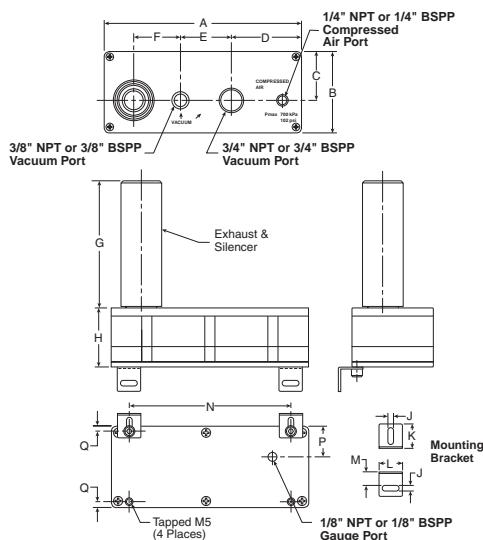

Item	A	B	C	D	E	F	G	H	J	K	L	M	N	P	Q	Weight (grams)
CHF-20	7.64 (194)	3.15 (80)	1.89 (48)	2.72 (69)	1.97 (50)	1.81 (46)	4.84 (123)	1.69 (43)	.22 (5.5)	.94 (24)	.91 (23)	.51 (13)	6.26 (159)	1.26 (32)	.20 (5)	875
CHF-30	7.64 (194)	3.15 (80)	1.89 (48)	2.72 (69)	1.97 (50)	1.81 (46)	4.84 (123)	1.69 (43)	.22 (5.5)	.94 (24)	.91 (23)	.51 (13)	6.26 (159)	1.26 (32)	.20 (5)	885
CHF-40	7.64 (194)	3.15 (80)	1.89 (48)	2.72 (69)	1.97 (50)	1.81 (46)	4.84 (123)	2.28 (58)	.22 (5.5)	.94 (24)	.91 (23)	.51 (13)	6.26 (159)	1.26 (32)	.20 (5)	965

Inches (mm)

SIS-001 silencer dimensions

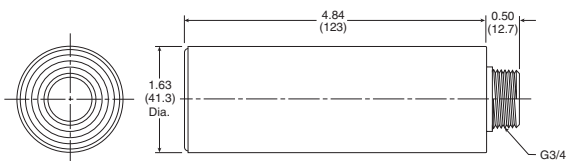

B
Generator Selection
MCA, CV, CV-GK
CHF
MC22
MC72
CEK
CVXCEK
MPS-23
MVS-201
Generator Accessories
Glossary

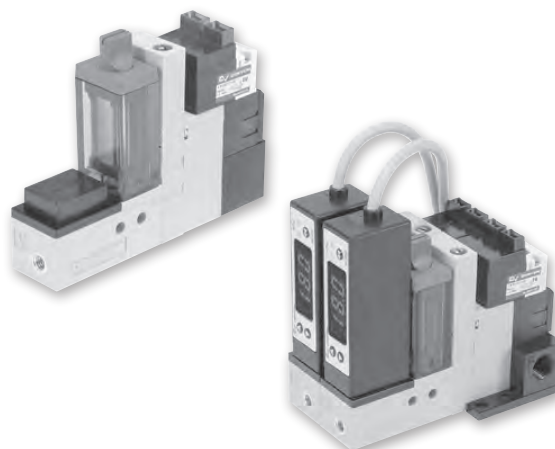

The MC22 is a complete package for factory automation. The MC22 has integrated vacuum generating and blow-off release pilot valves to minimize the response time to achieve vacuum. The small foot print and lightweight body allows the unit to be located close to the suction cup for maximum performance. The MC22 has additional features; regulating blow-off needle, 37 micron mesh filter, and a sensor platform for vacuum confirmation. The MC22 can be assembled into a maximum 8 station manifold. The unit can be ordered normally open or normally closed, with or without MPS-23 or MVS-201 pressure sensors.

Add-A-Fold Manifold
B
Features

- Vacuum generating pilot valve
- Vacuum blow-off pilot valve
- Vacuum sensor - filter - silencer available
- Regulating blow-off adjustment
- Manifold system
- Short cycle times for high speed pick and place
- Vacuum flow rates to 0.71 SCFM

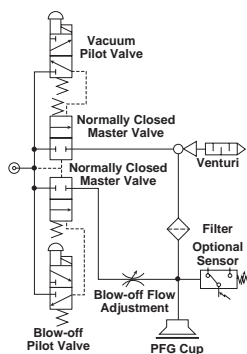
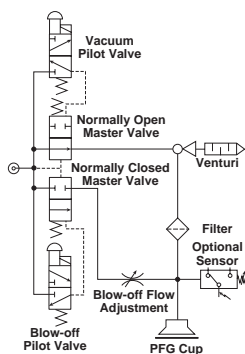
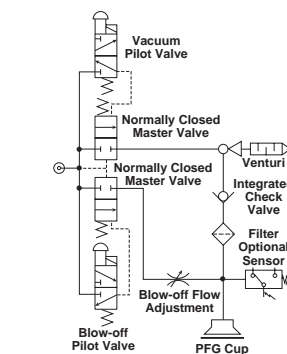
**MC22, Normally Closed
Vacuum Valve**

**MC22, Normally Open
Vacuum Valve**

**MC22, Normally Closed
Vacuum Valve with
Integrated Check Valve**
Specifications

Media	Non-lubricated compressed air, non-corrosive gases
Operating pressure	21 to 84 PSI (1.5 to 6 kgf/cm ²)
Optimum operating pressure	70 PSI (5 kgf/cm ²)
Humidity	35 to 85%
Pressure port	N: 1/8 NPT female, G: 1/8 BSPP female
Vacuum port	M5 female
Operating temperature	41 to 132°F (5 to 50°C)
Material	Aluminum, Polyamide, NBR
Vacuum generating and blow-off release pilot	
Type of control valve	Pilot valve, includes 300mm clip wire connector
Manual operation	Non-locking manual override
Electrical connection	Clip type connector with LED and surge protection
Power supply	24VDC ± 10%
Power consumption	1W
Pressure range	21 to 84 PSI (1.5 to 6 kgf/cm ²)
Pilot valve air supply	Normally closed
Generator weight	4.1 oz. (117G) without sensor
Manifold weight	2-Station: 1.4 oz. (40g), 3-Station: 2 oz. (54g), 4-Station: 2.4 oz. (68g), 5-Station: 2.8 oz. (82g), 6-Station: 3.4 oz. (96g), 7-Station: 3.8 oz. (110g), 8-Station: 4.4 oz. (124g)



MC22 unit without integrated check valve, normally closed vacuum valve

Port size			Max. vacuum flow SCFM	Max. degree of vacuum inHg	Sensor option	Part number	
Pressure	Vacuum	Exhaust				NPT	BSPP
1/8	M5	Muffler	0.71	24	None	MC22S10HSZL4BLN	MC22S10HSZL4BLG
1/8	M5	Muffler	0.71	24	MPS-V23C-PC, PNP	MC22S10HS42L4BLN	MC22S10HS42L4BLG
1/8	M5	Muffler	0.71	24	MVS-201-PCP, PNP	MC22S10HS06L4BLN	MC22S10HS06L4BLG
1/8	M5	Muffler	0.71	24	MPS-V23C-NC, NPN	MC22S10HS41L4BLN	MC22S10HS41L4BLG
1/8	M5	Muffler	0.71	24	MVS-201-NC, NPN	MC22S10HS01L4BLN	MC22S10HS01L4BLG

MC22 unit without integrated check valve, normally open vacuum valve

Port size			Max. vacuum flow SCFM	Max. degree of vacuum inHg	Sensor option	Part number	
Pressure	Vacuum	Exhaust				NPT	BSPP
1/8	M5	Muffler	0.71	24	None	MC22S10HSZL4ALN	MC22S10HSZL4ALG
1/8	M5	Muffler	0.71	24	MPS-V23C-PC, PNP	MC22S10HS42L4ALN	MC22S10HS42L4ALG
1/8	M5	Muffler	0.71	24	MPS-V23C-NC, NPN	MC22S10HS41L4ALN	MC22S10HS41L4ALG

MC22 unit with integrated check valve, normally closed vacuum valve

Port size			Max. vacuum flow SCFM	Max. degree of vacuum inHg	Sensor option	Part number	
Pressure	Vacuum	Exhaust				NPT	BSPP
1/8	M5	Muffler	0.71	24	None	MC22S10HSZLC4BLN	MC22S10HSZLC4BLG
1/8	M5	Muffler	0.71	24	MPS-V23C-PC, PNP	MC22S10HS42LC4BLN	MC22S10HS42LC4BLG
1/8	M5	Muffler	0.71	24	MVS-201-PCP, PNP	MC22S10HS06LC4BLN	MC22S10HS06LC4BLG
1/8	M5	Muffler	0.71	24	MPS-V23C-NC, NPN	MC22S10HS41LC4BLN	MC22S10HS41LC4BLG
1/8	M5	Muffler	0.71	24	MVS-201-NC, NPN	MC22S10HS01LC4BLN	MC22S10HS01LC4BLG

B

Generator Selection

MCA, CV, CV-GK

CHF

MC22

MC72

CEK

CVXCEK

MPS-23

MVS-201

Generator Accessories

Glossary

Most popular.



MC22 with MPS-23 series

The "V23" sensor has 2 independent NPN or PNP outputs available for vacuum confirmation. The output response time of this sensor is less than 2 msec.

The "V23" sensor is available with an M8, 4 Pin Connector, on 1M Cable. The mating M8, 4-Pin cable must be ordered separately.

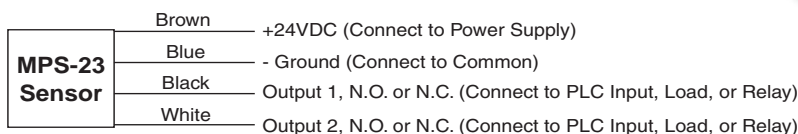

Output Adjustment

Sensor functions and outputs are programmed by touch panel.

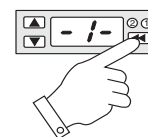

Basic System

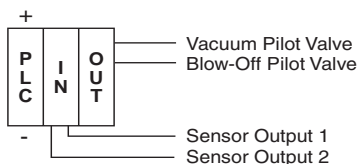

Air-Economizing System

N.C. Output 1 - Air Economizing
N.O. Output 2 - Part Present Output

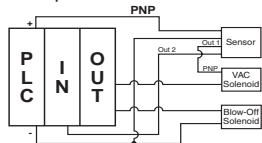

Vacuum System Programming

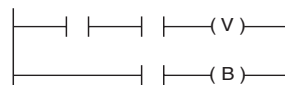

MC22 with MVS-201 series

The "201" sensor has one output NPN or PNP for vacuum confirmation and a control output that interfaces directly with the blow-off release pilot valve. With programmable time control features and a special chip driver, the sensor automatically activates the blow-off release when the NPN or PNP input vacuum signal from the PLC is discontinued. This eliminates a PLC output to activate the blow-off release. This new technology reduces PLC output requirements by 50% and reduces installation to a simple 4 wire system. The output response of the sensor is less than 2 msec.

The "201" sensor is available with an M8, 4-Pin electrical connector. The MC22-201 valve cable is included with the MVS-201 Sensor Option. The mating M8, 4-Pin cable must be ordered separately.

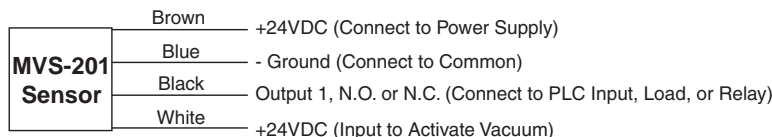
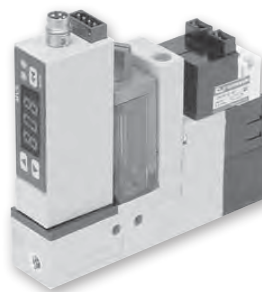

Basic System with 201 Sensor

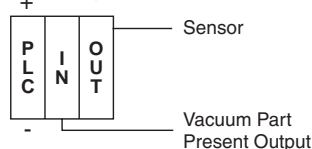

Vacuum System Programming

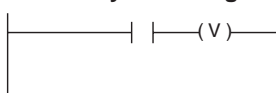

Output Adjustment

Sensor functions and outputs are programmed by touch panel.

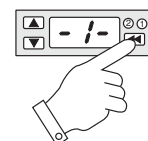

B

Generator Selection

MCA, CV, CV-GK

CHF

MC22

MC72

CEK

CVXCEK

MPS-23

MVS-201

Generator Accessories

Glossary





Station 1 Station 2

How to order Add-A-Fold assemblies

1. Manifold assemblies are multiple line item listings.
2. First line item must be the Add-A-Fold assembly part number.
3. Subsequent line items listed identify each station in the manifold starting with station number 1.
4. Station number 1 is the left most generator when looking at the manifold generator ports.
5. List either a part number of the MC22 Generator or a blank plate for each station of the manifold.
6. See model number index code for MC22 Generator number and MC22 accessories for blank plate part numbers.

AAMC2-M08N

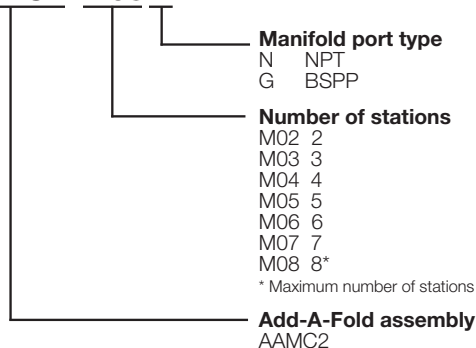

Example 1: Application requires an 2-Station MC22 manifold with NPT supply ports.

Qty.	Part number	Comment
1	AAMC2-M02N	Add-A-Fold
1	MC22S10HS42L4BLN.....	Station #1
1	MC22S10HS42L4BLN.....	Station #2
<i>Alternative Method</i>		
1	AAMC2-M02N	Add-A-Fold
2	MC22S10HS42L4BLN.....	Station #1-2

Manifold part number

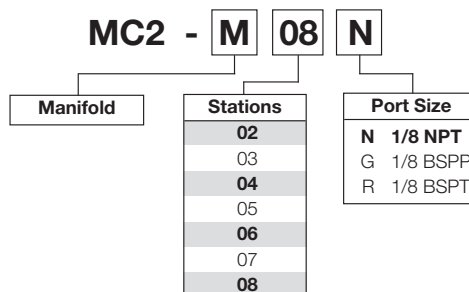

B	Generator Selection
	MCA, CV, CV-GK
	CHF
	MC22
	MC72
	CEK
	CVXCEK
	MPS-23
	MVS-201
	Generator Accessories
	Glossary

Most popular.



Generator

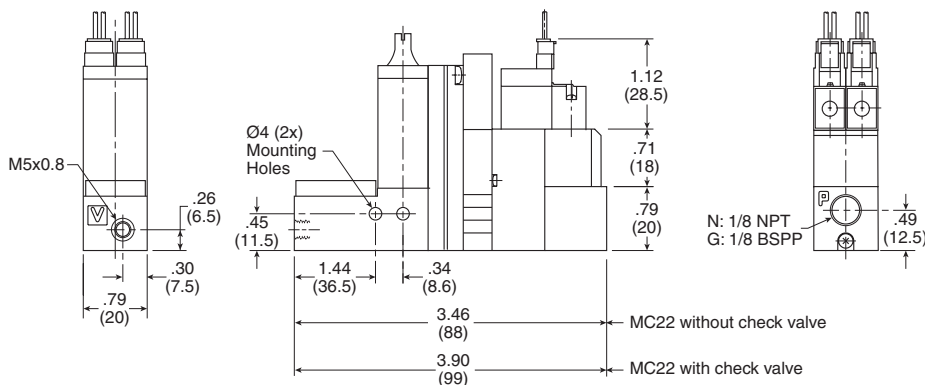

Manifold
3-Station manifold
without check
valve shown

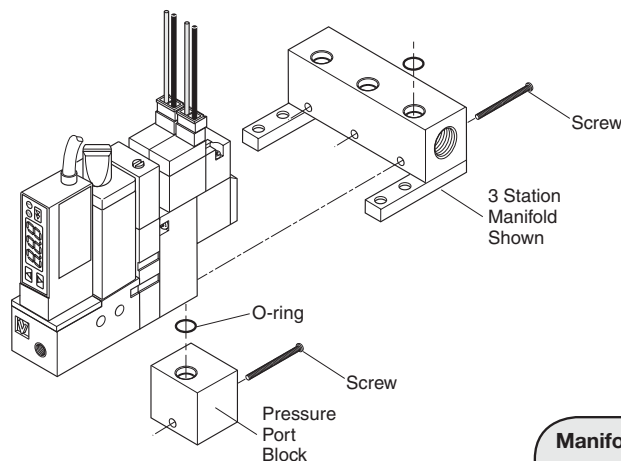
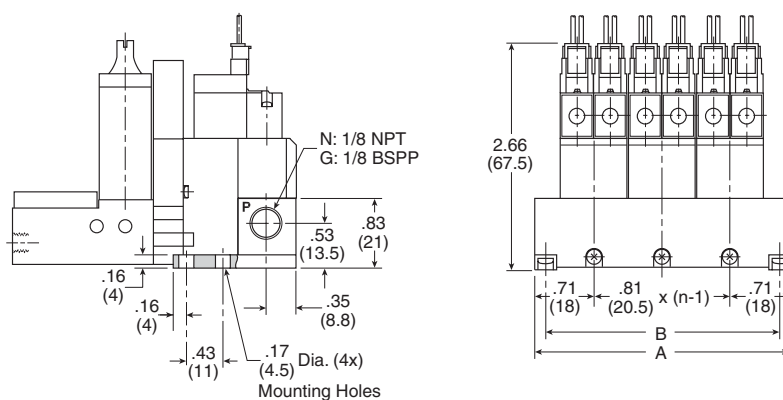

Manifold assembly
 Remove Pressure Port Block and use existing o-ring and screw to secure the MC22 unit to the MC2 manifold.

n	2	3	4	5	6	7	8
A	2.22 (56.5)	3.03 (77)	3.84 (97.5)	4.65 (118)	5.45 (138.5)	6.26 (159)	7.07 (179.5)
B	1.91 (48.5)	2.72 (69.0)	3.52 (89.5)	4.33 (110)	5.14 (130.5)	5.95 (151)	6.75 (171.5)

Inches (mm)
 n = Number of Stations

- B
- Generator Selection
- MCA, CV, CV-CK
- CHF
- MC22
- MC72
- CEK
- CVXCEK
- MPS-23
- MWS-201
- Generator Accessories
- Glossary

Replacement components

Item	Part number	Description
1	MC2-S	Silencer
2, 3, 4	MC2-F	Filter kit
3	MC2-E	Filter element
5, 7	CKV010-4E	Vacuum pilot valve
6, 7	CKV010-4E	Blow-off pilot valve
7	N/A	300mm clip lead
8	MC2-B	Mounting kit
9	MPS-V23C-NC	MPS-V23 (NPN) option
	MPS-V23C-PC	MPS-V23 (PNP) option
	MVS-201-NC	MVS-201 (NPN) option
	MVS-201-PCP	MVS-201 (PNP) option

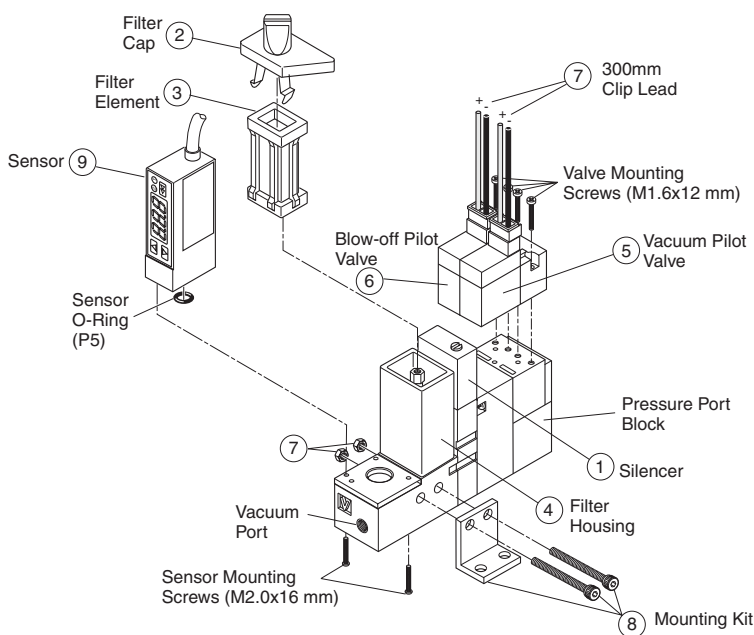

MC22 Accessories

Description	Part number
MC22 - C201G sensor / valve connector* (connects sensor to vacuum & blow-off release pilot valves) * Included with MVS-201 sensor option 01 & 06.	MC22-C201G
MC2-MM manifold blank plate kit* * includes blank plate, screws & gasket	MC2-M
Clip electrical connector, 600mm lead length	CA2-V4-6
Clip electrical connector, 1500mm lead length	CA2-V4-15

B
Generator Selection
MCA, CV, CV-GK
CHF
MC22
MC72
CEK
CVXCEK
MPS-23
MVS-201
Generator Accessories
Glossary

The MC72 Series vacuum generator provides a complete solution for factory automation. The MC72 is perfect for non-porous applications such as material handling, critical applications involving glass, or general transfer applications. The MC72 has integrated vacuum pilot and blow-off release pilot valves to minimize response times. The MC72 has additional features; regulating blow-off needle, 130 micron filter, optional check valve, and a sensor platform for vacuum confirmation. The MC72 can be assembled into a maximum 5 station manifold. The unit can be ordered normally open or normally closed.

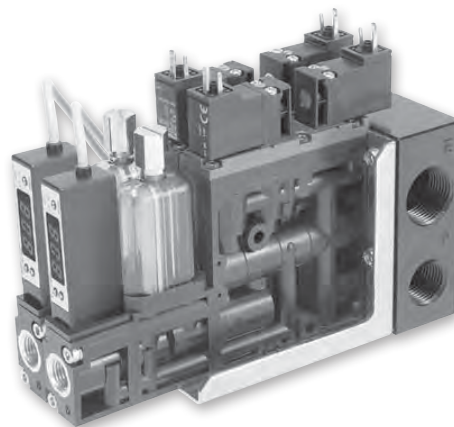
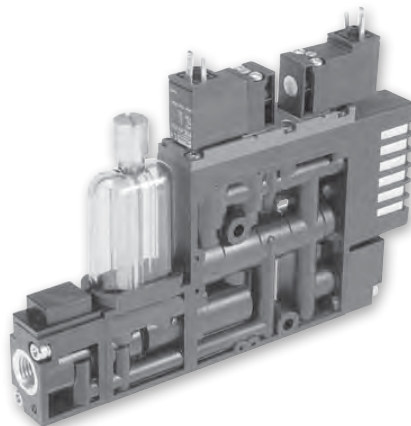
Add-A-Fold assembly (Silencer included)
Features

- Vacuum generating pilot valve
- Vacuum release pilot valve option
- Vacuum sensor - filter - silencer available
- Regulating blow-off
- Check valve option
- Air-economizing controls
- Manifold system
- Vacuum flow rates from 2.1 to 5.5 SCFM
- 3-Pin, EN175301-803, 15mm, 8mm 3-Pin

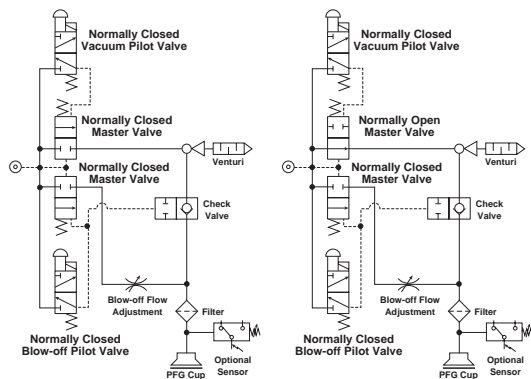
Specifications

Media	Non-lubricated compressed air, non-corrosive gases
Optimum operating pressure	70 PSI (5 kgf/cm ²)
Humidity	35 to 85%
Pressure port	N: 1/4 NPT female, G: 1/4 BSPP female
Vacuum port	N: 1/4 NPT female, G: 1/4 BSPP female
Operating temperature	41 to 132°F (5 to 50°C)
Material	Body (PA and PBT) with other internal components (Brass, Al.NBR, SUS, FKM), filter elements (PVF)
Manual operation	Non-locking manual override
Electrical connection	DIN connector with LED and surge protection
Power supply	24VDC ± 10%
Power consumption	1.8W
Operating pressure	70 PSI (5 kgf/cm ²)
Pilot valve air supply	Normally closed
Generator weight	12.0 oz. (340g)
Manifold weight	2-Station: 24 oz. (680g), 3-Station: 31 oz. (880g), 4-Station: 38 oz. (1080g), 5-Station: 45 oz. (1280g)



MC72 unit with integrated check valve, normally closed vacuum valve

Port size			Max. vacuum flow SCFM	Max. degree of vacuum inHg	Sensor option	Part number	
Pressure	Vacuum	Exhaust				NPT	BSPP
1/4	1/4	Muffler	2.20	24	No sensor	MC72S15HSZSC4BPN	MC72S15HSZSC4BPG
1/4	1/4	Muffler	2.20	24	MPS-V23C-PC, PNP	MC72S15HS42C4BPN	MC72S15HS42C4BPG
1/4	1/4	Muffler	2.20	24	MVS-201-PCP, PNP	MC72S15HS06C4BPN	MC72S15HS06C4BPG
1/4	1/4	Muffler	2.20	24	MPS-V23C-NC, NPN	MC72S15HS41C4BPN	MC72S15HS41C4BPG
1/4	1/4	Muffler	2.20	24	MVS-201-NC, NPN	MC72S15HS01C4BPN	MC72S15HS01C4BPG
1/4	1/4	Muffler	3.67	24	No sensor	MC72S20HSZSC4BPN	MC72S20HSZSC4BPG
1/4	1/4	Muffler	3.67	24	MPS-V23C-PC, PNP	MC72S20HS42C4BPN	MC72S20HS42C4BPG
1/4	1/4	Muffler	3.67	24	MVS-201-PCP, PNP	MC72S20HS06C4BPN	MC72S20HS06C4BPG
1/4	1/4	Muffler	3.67	24	MPS-V23C-NC, NPN	MC72S20HS41C4BPN	MC72S20HS41C4BPG
1/4	1/4	Muffler	3.67	24	MVS-201-NC, NPN	MC72S20HS01C4BPN	MC72S20HS01C4BPG
1/4	1/4	Muffler	5.20	24	No sensor	MC72S25HSZSC4BPN	MC72S25HSZSC4BPG
1/4	1/4	Muffler	5.20	24	MPS-V23C-PC, PNP	MC72S25HS42C4BPN	MC72S25HS42C4BPG
1/4	1/4	Muffler	5.20	24	MVS-201-PCP, PNP	MC72S25HS06C4BPN	MC72S25HS06C4BPG
1/4	1/4	Muffler	5.20	24	MPS-V23C-NC, NPN	MC72S25HS41C4BPN	MC72S25HS41C4BPG
1/4	1/4	Muffler	5.20	24	MVS-201-NC, NPN	MC72S25HS01C4BPN	MC72S25HS01C4BPG

MC72 unit with integrated check valve, normally open vacuum valve

Port size			Max. vacuum flow SCFM	Max. degree of vacuum inHg	Sensor option	Part number	
Pressure	Vacuum	Exhaust				NPT	BSPP
1/4	1/4	Muffler	2.20	24	No sensor	MC72S15HSZSC4APN	MC72S15HSZSC4APG
1/4	1/4	Muffler	2.20	24	MPS-V23C-PC, PNP	MC72S15HS42C4APN	MC72S15HS42C4APG
1/4	1/4	Muffler	2.20	24	MPS-V23C-NC, NPN	MC72S15HS41C4APN	MC72S15HS41C4APG
1/4	1/4	Muffler	3.67	24	No sensor	MC72S20HSZSC4APN	MC72S20HSZSC4APG
1/4	1/4	Muffler	3.67	24	MPS-V23C-PC, PNP	MC72S20HS42C4APN	MC72S20HS42C4APG
1/4	1/4	Muffler	3.67	24	MPS-V23C-NC, NPN	MC72S20HS41C4APN	MC72S20HS41C4APG
1/4	1/4	Muffler	5.20	24	No sensor	MC72S25HSZSC4APN	MC72S25HSZSC4APG
1/4	1/4	Muffler	5.20	24	MPS-V23C-PC, PNP	MC72S25HS42C4APN	MC72S25HS42C4APG
1/4	1/4	Muffler	5.20	24	MPS-V23C-NC, NPN	MC72S25HS41C4APN	MC72S25HS41C4APG

B
Generator Selection
MCA, CV, CV-GK
CHF
MC22
MC72
CEK
CVXCEK
MPS-23
MVS-201
Generator Accessories
Glossary

Most popular.



MC72 with MPS-23 series

The "V23" sensor has 2 independent NPN or PNP outputs available for vacuum confirmation. The output response time of this sensor is less than 2 msec.

The "V23" sensor is available with an M8, 4-Pin or grommated (2M) electrical connector. The mating M8, 4-Pin cable is not included with the MPS-23 Sensor and must be ordered separately.

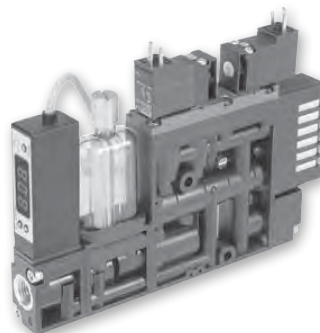

Output Adjustment

Sensor functions and outputs are programmed by touch panel.

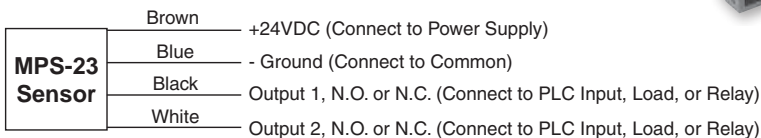
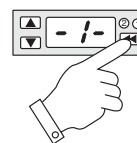

Basic System

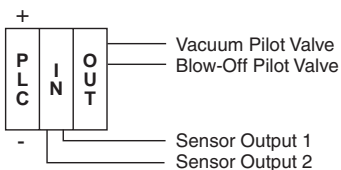

Air-Economizing System

N.C. Output 1 - Air Economizing
N.O. Output 2 - Part Present Output

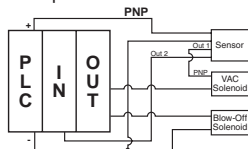

Vacuum System Programming

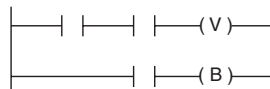

MC72 with MVS-201 series

The "201" sensor has one output NPN or PNP for vacuum confirmation and a control output that interfaces directly with the blow-off release pilot valve. With programmable time control features and a special chip driver, the sensor automatically activates the blow-off release when the NPN or PNP input vacuum signal from the PLC is discontinued. This eliminates a PLC output to activate the blow-off release. This new technology reduces PLC output requirements by 50% and reduces installation to a simple 4 wire system. The output response of the sensor is less than 2 msec.

The "201" sensor is available with an M8, 4-Pin electrical connector. The CVK-D201G valve cable is included with the MVS-201 Sensor Option. The mating M8, 4-Pin cable must be ordered separately.

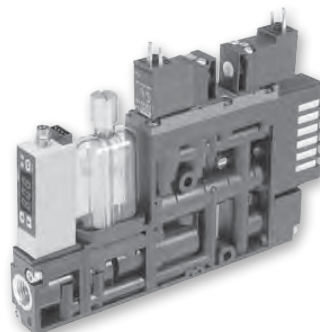

Output Adjustment

Sensor functions and outputs are programmed by touch panel.

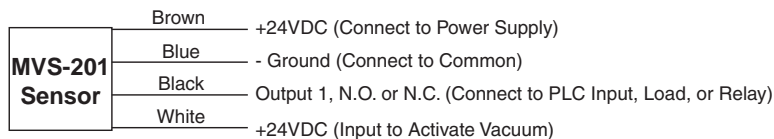
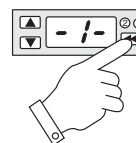

Basic System with 201 Sensor

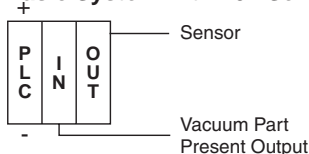

Vacuum System Programming

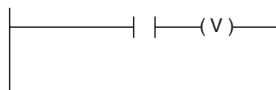

B	Generator Selection
	MCA, CV, CV-CK
	CHF
	MC22
MC72	
CEK	
CVXCEK	
MPS-23	
MVS-201	
Generator Accessories	
Glossary	



Ordering Information



How to order Add-A-Fold assemblies

1. Manifold assemblies are multiple line item listings.
2. First line item must be the Add-A-Fold assembly part number.
3. Subsequent line items listed identify each station in the manifold starting with station number 1.
4. Station number 1 is the left most generator when looking at the manifold generator ports.
5. List either a part number of the manifold type generator or a blank plate for each station of the manifold.
6. See model number index code for MC72 Generator number and accessories for blank plate part numbers.

AAMC72-M02N

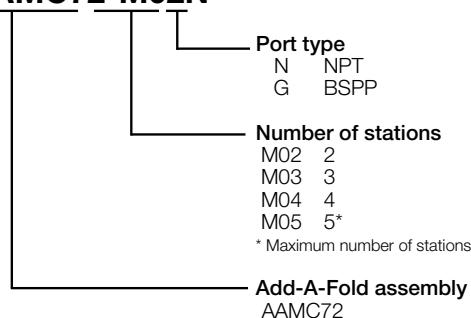

Example 1: Shown above is a 2-Station MC72 Manifold with sensors and NPT ports.

Qty.	Part number	Comment
1	AAMC72-M02N	Add-A-Fold
1	MC72SHS42C4BPN	Station #1
1	MC72SHS42C4BPN	Station #1
Alternative Method		
1	AAMC72-M02N	Add-A-Fold
2	MC72SHS42C4BPN	Station #1-2

Manifold part number

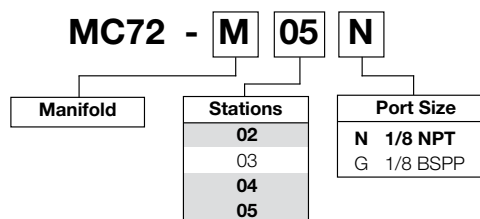

B
Generator Selection
MCA, CV, CV-GK
CHF
MC22
MC72
CEK
CVXCEK
MPS-23
MVS-201
Generator Accessories
Glossary

Most popular.



Generator

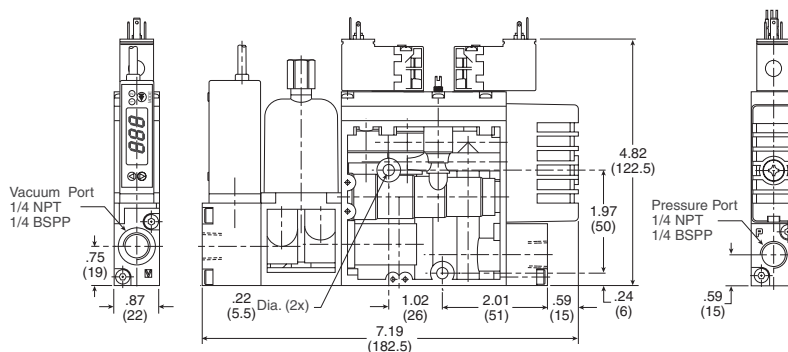

Manifold

3-Station manifold shown

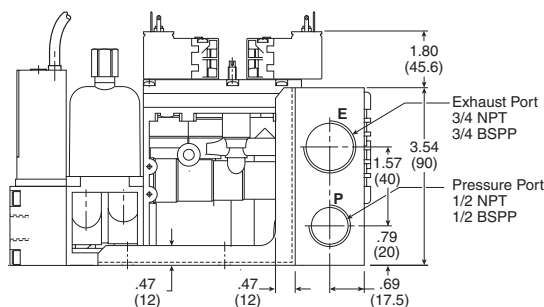
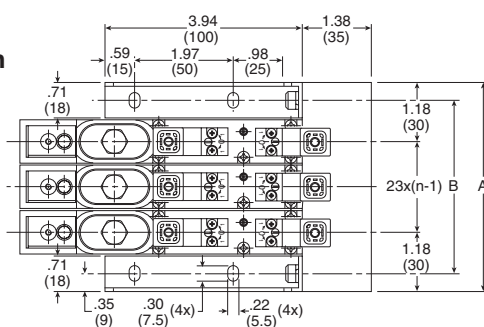

Manifold Assembly

1. Assemble manifold sections to manifold end plates as shown.
2. Assemble vacuum generator by removing pressure block and exhaust muffler and add using exiting screws and orings.

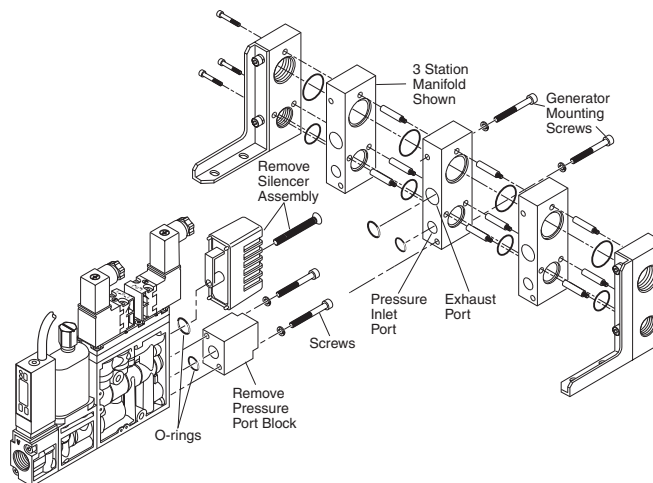

n	2	3	4	5
A	3.27 (83)	4.17 (106)	5.08 (129)	5.98 (152)
B	2.56 (65)	3.46 (88)	4.37 (111)	5.28 (134)

Inches (mm)

n = Number of Stations



Replacement components

Item	Part number	Description
1	CVK-S	Silencer
2 thru 7	CVK-F	Filter kit
5	CVK-E	Filter element
8	PS294679BP	DIN connector with LED
8, 9, 10	MC72-4PD	Pilot valve kit
11	MPS-V23C-NC	MPS-V23 (NPN) option
	MPS-V23C-PC	MPS-V23 (PNP) option
	MVS-201-NC	MVS-201 (NPN) option
	MVS-201-PCP	MVS-201 (PNP) option

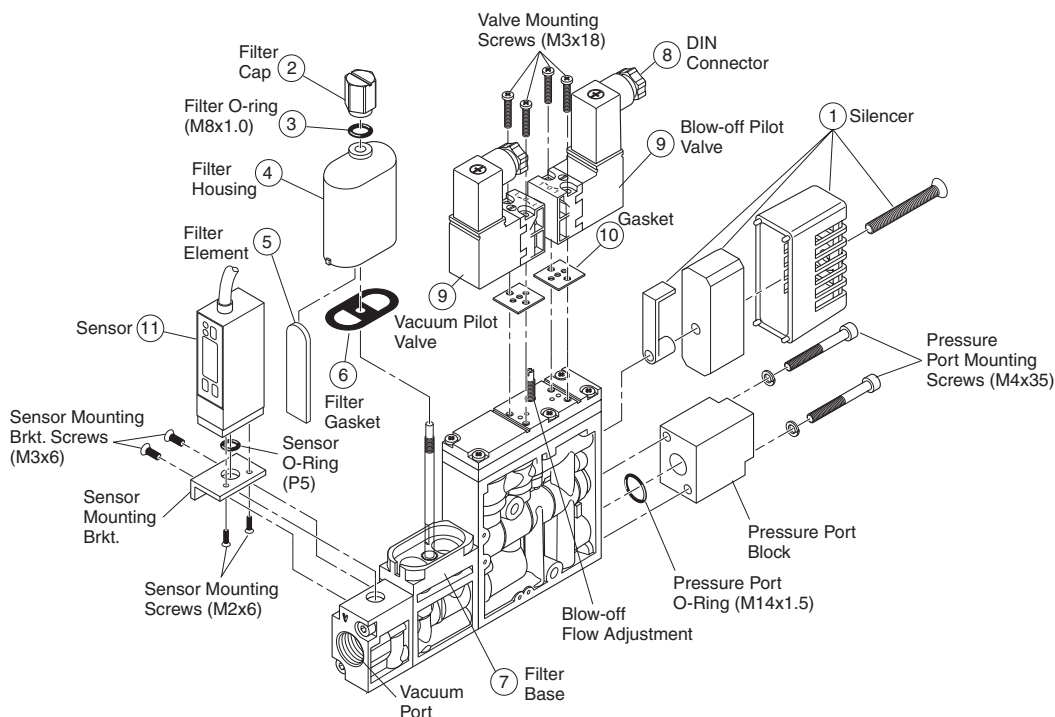

CVK-D201G Valve Cable*

(Connects Sensor to Vacuum & Blow-off Release Pilot Valves)

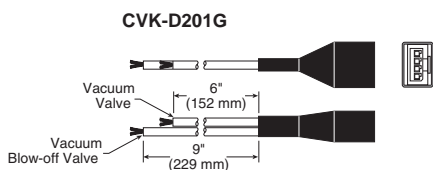

* Included with MVS-201 Sensor Option 01 & 06.

Generator Blank Plate Kit

CVK-BLK

Kit includes: Blank plate, screws & o-rings

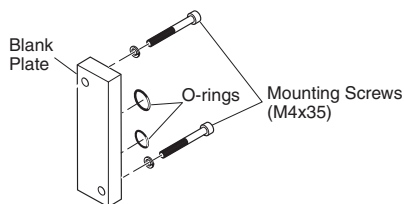

B
Generator Selection
MCA, CV, CV-GK
CHF
MC22
MC72
CEK
CVXCEK
MPS-23
MVS-201
Generator Accessories
Glossary

The CEK is a Normally Closed Vacuum On / Off valve that maintains the last state of air during an emergency stop or power loss. In addition to this, an air-economizing valve has been added to interrupt the air supply by connecting the output signal from the sensor to minimize air consumption.

This unit is ideal for non-porous applications that require fast response of large vacuum and blow-off release flow.

Typically, with a normally closed air circuit, the user controls vacuum with a command signal. During an Emergency Stop Event or power failure event, the vacuum command signal is lost, but, the Vacuum valve (1) remains in the current operating position due to the valve. The air-economizing valve (5), in a Normally Open configuration, passes the air supply from the Vacuum On / Off valve (1). The Sensor (2) output activates the air-economizing valve (5) closing the air supply to the Normally Closed master valve. The Check Valve (3) maintains the achieved vacuum level until the hysteresis value of the Sensor (2) is reached or when the Vacuum valve (1) has been returned to the closed position to stop the vacuum operation.

Valve controlled emergency stop circuit

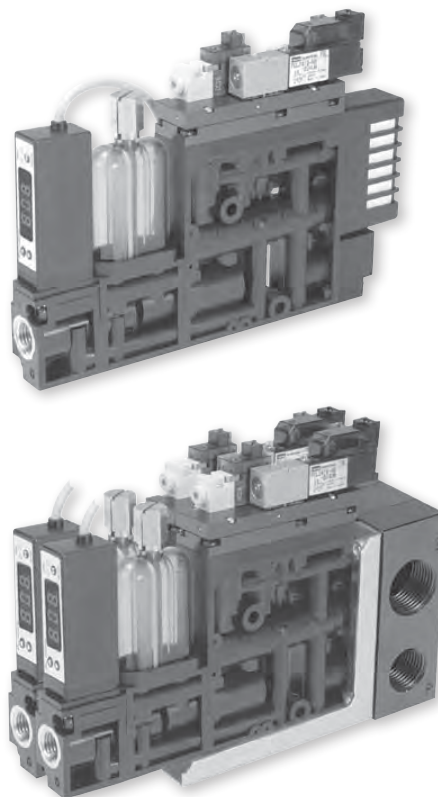
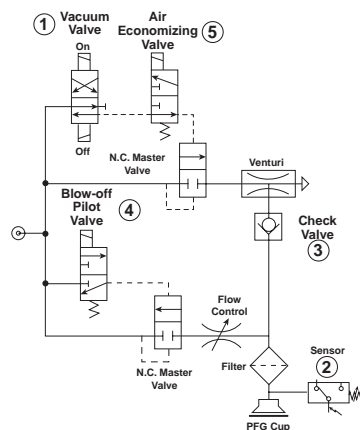

Add-A-Fold assembly (Silencer included)

Features

- Integrated double solenoid for last state
- Integrated vacuum pilot
- Integrated blow-off pilot
- Integrated filter, silencer
- Air economizing capabilities
- Manifolds for up to 5 units

CEK Model Number

Port size		Max. vacuum flow		Max. degree of vacuum		Part number	
Pressure	Vacuum	Exhaust	SCFM	inHg	Sensor option	NPT	BSPP
1/4	1/4	Muffler	2.20	24	No sensor	CEK15HSZC24PBLNB	CEK15HSZC24PBLGB
1/4	1/4	Muffler	2.20	24	MPS-V23C-NC, NPN	CEK15HS41C24NBLNB	CEK15HS41C24NBLGB
1/4	1/4	Muffler	2.20	24	MPS-V23C-PC, PNP	CEK15HS42C24PBLNB	CEK15HS42C24PBLGB
1/4	1/4	Muffler	3.67	24	No sensor	CEK20HSZC24PBLNB	CEK20HSZC24PBLGB
1/4	1/4	Muffler	3.67	24	MPS-V23C-NC, NPN	CEK20HS41C24NBLNB	CEK20HS41C24NBLGB
1/4	1/4	Muffler	3.67	24	MPS-V23C-PC, PNP	CEK20HS42C24PBLNB	CEK20HS42C24PBLGB
1/4	1/4	Muffler	5.20	24	No sensor	CEK25HSZC24PBLNB	CEK25HSZC24PBLGB
1/4	1/4	Muffler	5.20	24	MPS-V23C-NC, NPN	CEK25HS41C24NBLNB	CEK25HS41C24NBLGB
1/4	1/4	Muffler	5.20	24	MPS-V23C-PC, PNP	CEK25HS42C24PBLNB	CEK25HS42C24PBLGB

Most popular.

B

Generator Selection

MCA, CV, CV-CK

CHF

MC22

MC72

CEK

CVXCIEK

MPS-23

MVS-201

Generator Accessories

Glossary



Specifications

Media	Non-lubricated compressed air, non-corrosive gases	
Operating pressure	70 PSI (5 kgf/cm ²)	
Humidity	35 to 85%	
Pressure port	N: 1/4 NPT female, G: 1/4 BSPP female	
Vacuum port	N: 1/4 NPT female, G: 1/4 BSPP female	
Operating temperature	41 to 132°F (5 to 50°C)	
Material	Body (PA and PBT) with other internal components (Brass, Al.NBR, SUS, FKM), filter elements (PVF)	
Air-economizing valve and blow-off release pilot	Vacuum on/off valve	
Type of control valve	Pilot valve	Double solenoid
Manual operation	Manual override	Manual overrides
Electrical connection	Clip connector with LED and surge	Clip connector with LED and surge
Power supply	24VDC ± 10%	24VDC ± 10%
Power consumption	0.9W	0.9W
Operating pressure	70 PSI (5 kgf/cm ²)	70 PSI (5 kgf/cm ²)
Air supply	Normally closed	Normally closed
Generator weight	12.0 oz. (340g)	
Manifold weight	2-Station: 24 oz. (680g), 3-Station: 31 oz. (880g), 4-Station: 38 oz. (1080g), 5-Station: 45 oz. (1280g)	

B

Generator Selection

MCA, CV, CV-GK

CHF

MC22

MC72

CEK

CVXCEK

MPS-23

MVS-201

Generator Accessories

Glossary



Ordering Information

B
Generator Selection
MCA, CV, CV-CK
CHF
MC22
MC72
CEK
CVXCEK
MPS-23
MWS-201
Generator Accessories
Glossary

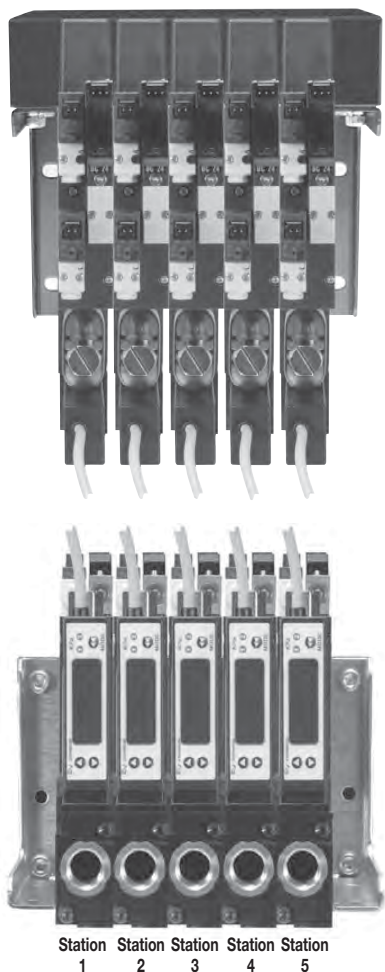

How to order Add-A-Fold assemblies

1. Manifold assemblies are multiple line item listings.
2. First line item must be the Add-A-Fold assembly part number.
3. Subsequent line items listed identify each station in the manifold starting with station number 1.
4. Station number 1 is the left most generator when looking at the manifold generator ports.
5. List either a part number of the manifold type generator or a blank plate for each station of the manifold.
6. See model number index code for CEK Generator number and accessories for blank plate part numbers.

AACEK-M05N

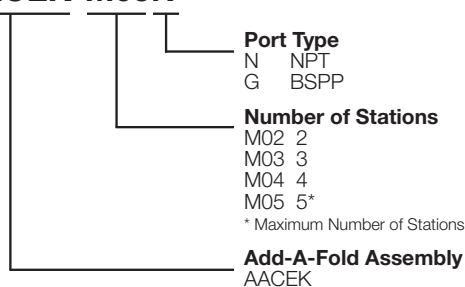

Note: Uses same manifold as MC72 Generator

Example 1: Shown above is a 5-Station CEK manifold with sensors and NPT ports.

Manifold part number

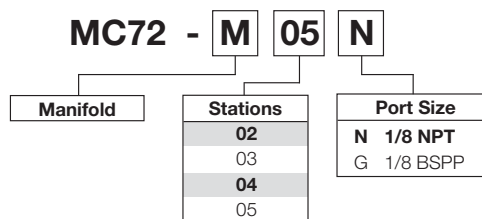

Note: Uses same manifold as MC72 Generator

Qty.	Part number	Comment
1	AACEK-M05N.....	Add-A-Fold
1	CEK15HS42C24NBLNB.....	Station #1
1	CEK15HS42C24NBLNB.....	Station #2
1	CEK20HS42C24NBLNB.....	Station #3
1	CEK20HS42C24NBLNB.....	Station #4
1	CEK25HS42C24NBLNB.....	Station #5
Alternative Method		
1	AACEK-M05N.....	Add-A-Fold
2	CEK15HS42C24NBLNB.....	Station #1-2
2	CEK20HS42C24NBLNB.....	Station #3-4
1	CEK25HS42C24NBLNB.....	Station #5

Most popular.



Generator

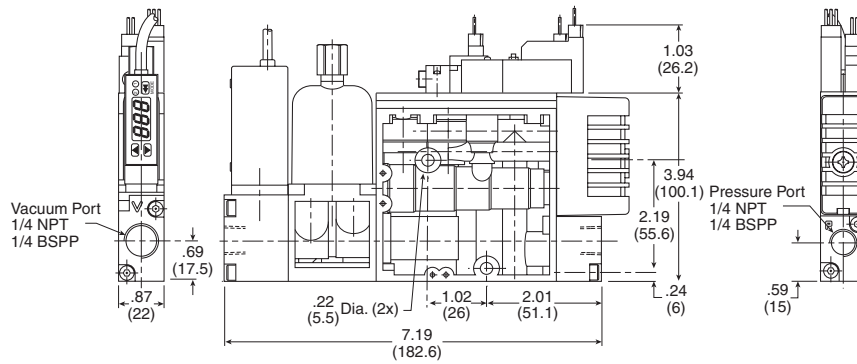

Manifold

3-Station manifold shown

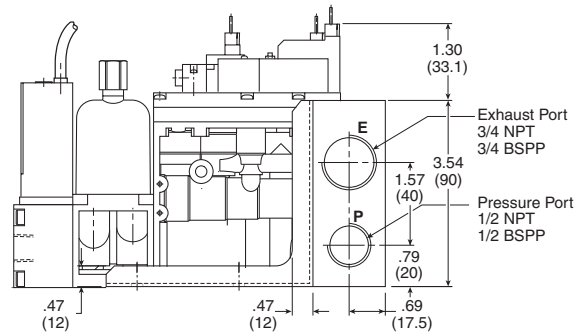
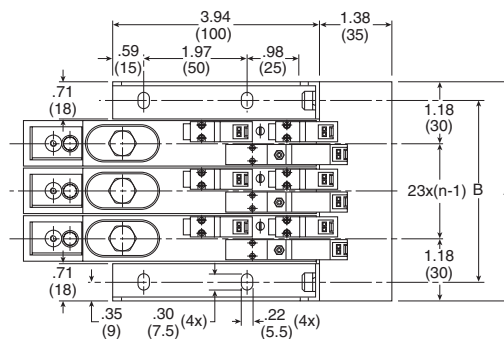

Manifold assembly

Remove Pressure Port Block and Silencer Assembly. Use existing o-rings and manifold mounting screws to secure the CEK unit to the manifold.

n	2	3	4	5
A	3.27 (83)	4.17 (106)	5.08 (129)	5.98 (152)
B	2.56 (65)	3.46 (88)	4.37 (111)	5.28 (134)

Inches (mm)
 n = Number of Stations

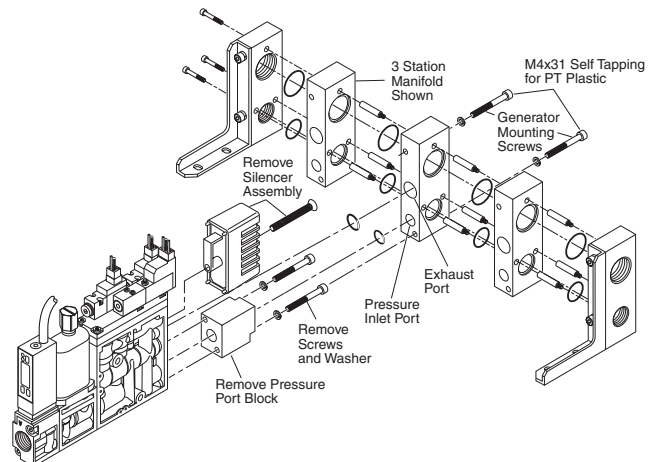

B
Generator Selection
MCA, CV, CV-GK
CHF
MC22
MC72
CEK
CVXCEK
MPS-23
MVS-201
Generator Accessories
Glossary



Replacement components

Item	Part number	Description
1	CVK-S	Silencer
2 thru 7	CVK-F	Filter kit
5	CVK-E	Filter element
8, 10	MC2-24-B-10-D	Blow-off Pilot Valve
9, 10	MC2-24-B-10-V	Air-Economizing Valve
10	MC2-5L	500mm clip lead
11,13	VA01PLC241PE	Vacuum on / off valve, NPN
12,13	PCL241B-NB-D24UM	Vacuum on / off valve, PNP
13	PCL2-D24-CL5	500mm clip lead
Item	Part number	Replacement sensor
14	MPS-V23C-NC	MPS-V23 (NPN) option
	MPS-V23C-PC	MPS-V23 (PNP) option

⚠ Cautions

Do not use or expose the CEK with fluids or corrosive gases. Vacuum Venturi's are designed to be used with non-lubricated, non-corrosive, compressed air.

Do not operate CEK generators outside the temperature range and pressures listed in the specifications section of this catalog. Regulate the compressed air to 70PSI and filtrate with a maximum 40 micron filter. Non-lubricated compressed air will maintain the life and vacuum level of the generator.

Check the insulation of all lead wires after installation to avoid shorts. Properly secure all lead wires to avoid stress or repeated movement that may fray lead wires.

Some electrical components are diode or zener diode protected. When installing solenoids and sensors, check the polarity of the component before applying power. Apply the appropriate voltage to the solenoids and sensors. Inappropriate voltage, shorts, or surges may damage the circuitry.

B

Generator Selection

MCA, CV, CV-CK

CHF

MC22

MC72

CEK

CVXCEK

MPS-23

MVS-201

Generator Accessories

Glossary

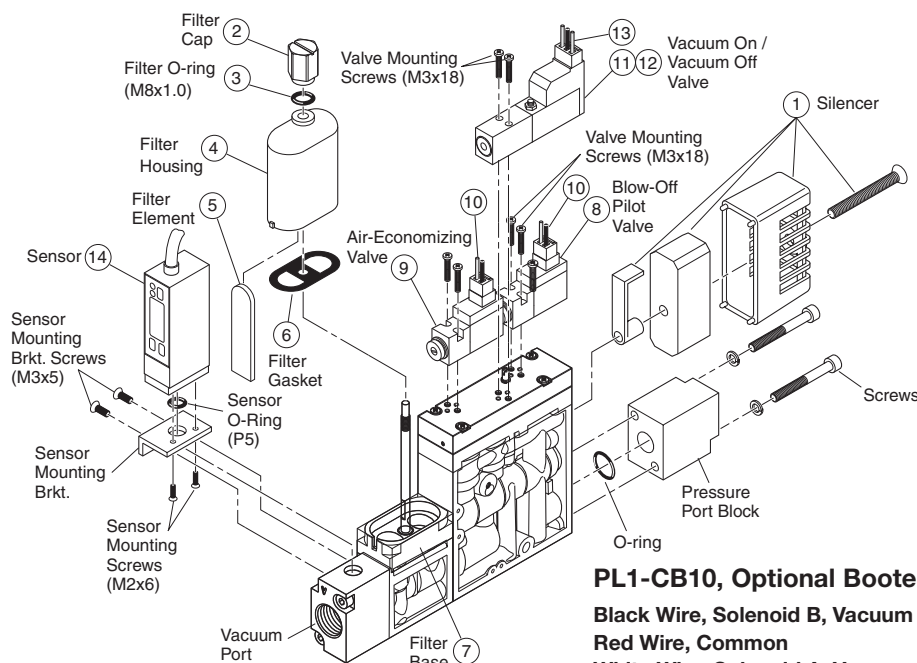

PL1-CB10, Optional Booted Cable

Black Wire, Solenoid B, Vacuum Off
Red Wire, Common
White Wire, Solenoid A, Vacuum On

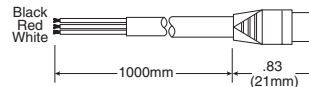

Pilot Valve Cable

MC2-5L (500mm) Lead*
(Connects Power Source to Vacuum & Blow-off Release Pilot Valves)

Positive "+" (Red Wire)
Negative "-" (Black Wire)
* Included with Generator

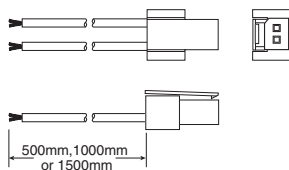

PCL2-D24-CL5* Cable

Black Wire, Solenoid B, Vacuum On
Red Wire, Common
Yellow Wire, Solenoid A, Vacuum Off
*Included with Generator

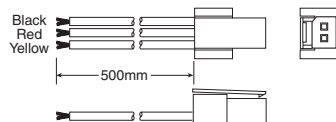

MC2-CB10 Valve Cable

(Connects Power Source to Vacuum & Blow-off Release Pilot Valves)
Positive "+" (Red Wire)
Negative "-" (Black Wire)

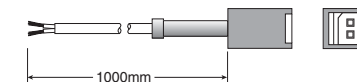

CEK - System logic

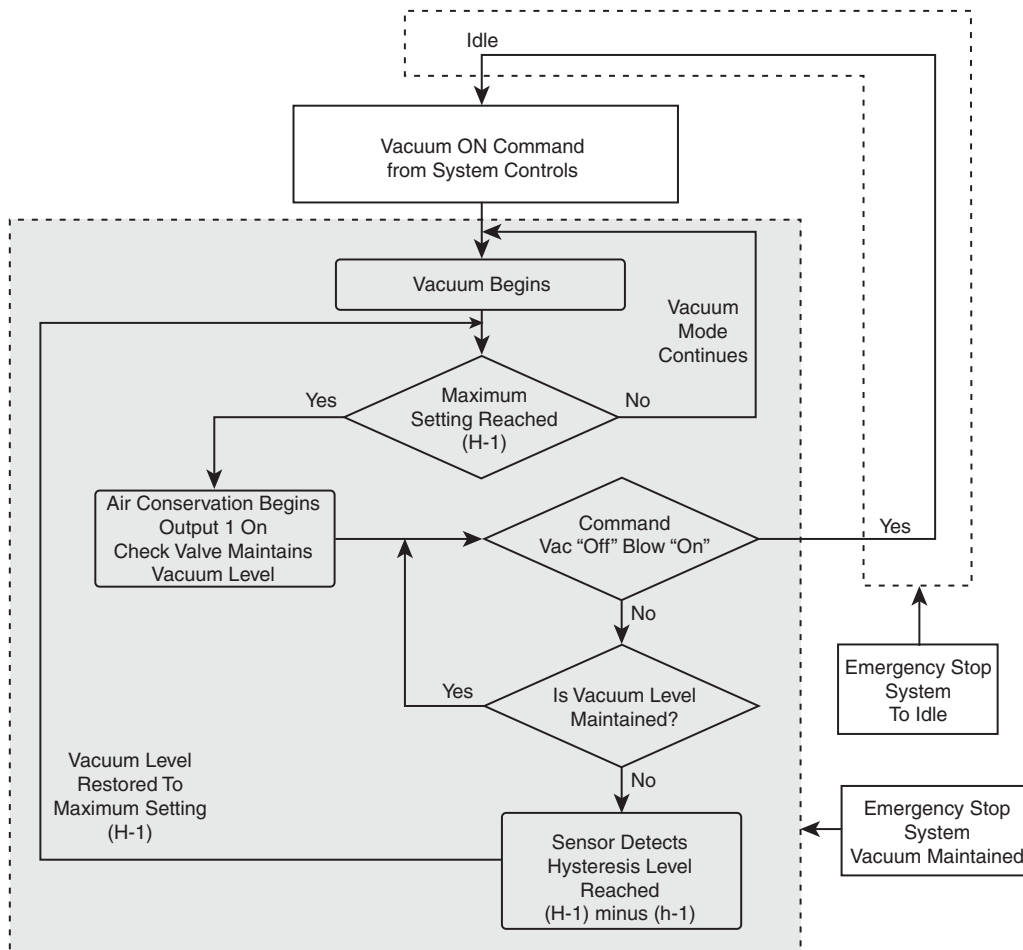



B
Generator Selection
MCA, CV, CV-GK
CHF
MC22
MC72
CEK
CVXCEK
MPS-23
MVS-201
Generator Accessories
Glossary

CEK - Emergency Stop Operating System (EOS)

The Emergency Stop Operating System is designed to maintain the last state of operation when an emergency stop or power failure occurs.

The chart below illustrates the state of operation in different modes.

Modes	Vacuum On	Vacuum Off	Blow-Off	EOS
Normal Conditions	Air-Economizing between 18-16 inHg	Idle	Blow-Off On Blow-Off Idle	EOS Off
Emergency Stop, Power Failure	Vacuum On 	Idle	Blow-Off On or Idle 	EOS On
Restore Power	Vacuum On Air-Economizing Function Resumes	Idle	Idle	EOS Off



Features & Characteristics

The CVXCEK vacuum generator creates vacuum and blow-off pressure in a vacuum system and has additional Air-economizing and emergency operating system functions.

Each CVXCEK unit consists of 2 independent vacuum generators labeled channel 1 and channel 2. Each vacuum generator has a vacuum ON / OFF solenoid pilot valve, blow-off solenoid pilot valve, Air-Economizing valve, blow-off needle control valve, pressure sensor, vacuum check valve, vacuum filter, and exhaust filter. Each Vacuum Generator is mounted to a 2-Station bar manifold with an optional electrical mounting kit. The pressure provided to inlet port of the bar manifold is common to both vacuum generators.

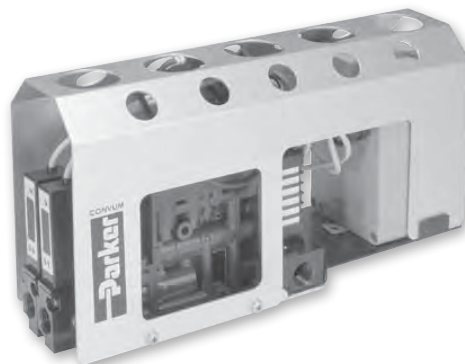

Features

- Integrated double solenoid for hold last state conditions
- Integrated vacuum pilot
- Integrated blow-off pilot
- Integrated filter, silencer
- Air economizing capabilities

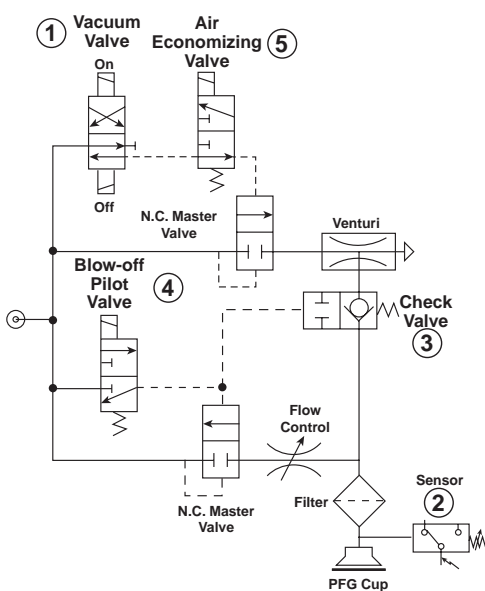

General operation of CVXCEK vacuum units

A vacuum generator is a single stage Venturi that creates vacuum pressure using compressed air. In principle, compressed air is throttled as the air exits the nozzle and is discharged into the diffuser. This increased velocity of air lowers the pressure in the diffusion chamber. The volume of air within the closed vacuum system flows into the low-pressure area of the diffusion chamber and is exhausted thru the diffuser. This effect increases the vacuum level and evacuates most of the air within the closed vacuum. The vacuum generator will produce the specified degrees of vacuum as cataloged if the vacuum system is closed, inlet pressure is to design pressure, and there are no major restrictions in the exhaust flow.

Vacuum is created when the unit receives a momentary or maintained command vacuum "ON" signal, (high signal is sent to Vacuum Pilot Valve (1). Once a preset vacuum degree (P-1) of the pressure sensor (2) is achieved, the Air-Economizing Valve is enabled to conserve compressed air. The vacuum level will be maintained by the Check Valve (3) until the switch point (P-1) is achieved again. This cycle, which is called Air-economizing, will repeat until a blow-off signal is sent to the unit. When the Blow-off Pilot Valve (4) is activated to decay the vacuum pressure, the unit will release the part. Command vacuum "ON" should be turned "OFF" when command blow-off is turned "ON". The Emergency Stop operating system provides Air-Economizing or maximum degree of vacuum at the time of disruption of Input and Output Power.

B	Generator Selection
	MCA, CV, CV-CK
	CHF
	MC22
	MC72
	CEK
	CVXCEK
	MPS-23
	MVS-201
	Generator Accessories
Glossary	



Ordering & Technical Information

Model Number Index

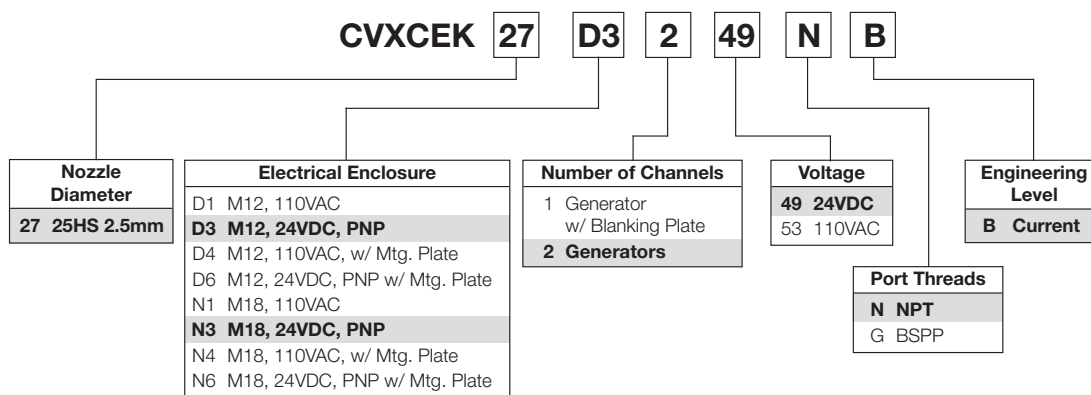

Specifications

Media	Non-lubricated compressed air, non-corrosive gases		
Operating pressure	70 PSI		
Humidity	35 to 85%		
Pressure port	N: 1/4 NPT female, G: 1/4 BSPP female		
Vacuum port	N: 3/8 NPT female, G: 3/8 BSPP female		
Operating temperature	41 to 132°F (5 to 50°C)		
Material	Body (PA, PBT) Brass, Al, NBR, SUS, FKM		
Air-economizing valve and blow-off release pilot	Vacuum pilot valve	Sensors	
Type of control	Single solenoid	Double solenoid	MPS-23 Pressure Sensor
Manual operation	Manual override	Manual overrides	N/A
Electrical connection	Clip connector	Clip connector	M8, 4-pin
Power supply*	24VDC ± 10%	24VDC ± 10%	10.8 to 30VDC
Solenoid power consumption	0.6W with LED and surge	2.0W with LED and surge	55mA
Operating pressure	70 PSI	70 PSI	-14.7 PSI to 72.5 PSI
Air supply	Normally closed	Normally closed	N/A
Manifold weight	1-Station: 49 oz. (1404g), 2-Station: 63 oz. (1787g)		

* 110VAC units use 24VDC solenoids and sensors.

Performance

Series / nozzle diameter	Nozzle diameter (mm)	Vacuum degree at 70 PSI (inHg)	Vacuum flow per channel (SCFM)	Air consumption per channel (SCFM)
CVXCEK27	2.5	27	5.20	9.36

Evacuation time

Series / nozzle diameter	Air supply pressure PSI	Air consumption per channel SCFM	Evacuation time per channel in sec / ft³ * to reach different vacuum levels (inHg)								
			3	6	9	12	15	18	21	24	27
CVXCEK27	70	10.42	0.7	2.2	3.3	6.1	9.3	14.5	23.2	46.1	—

* 1 ft³ = 28.31 liters

Vacuum flow (SCFM)

Series / nozzle diameter	inHg											
	0	3	6	9	12	15	18	21	24	27	30	
CVXCEK27	5.20	4.60	4.01	3.41	2.80	2.22	1.63	1.04	0.46	—	—	

☐ Most popular.

B

Generator Selection

MCA, CV, CV-GK

CHF

MC22

MC72

CEK

CVXCEK

MPS-23

MVS-201

Generator Accessories

Glossary



Description & Operation

Sensor output function

Sensor outputs are open collector transistor type. Replacement Sensor MPS-V23C-NC is an NPN Sinking Sensor. When installed on the CVXCEK, the onboard electronics converts this sensor to a PNP circuit. Wiring circuit of the CVXCEK units is PNP, Sourcing. Each vacuum generator sensor has 2 outputs. Output 1 and Output 2 are independent of each other and have different factory set conditions. These settings can be changed with the touch pad programming.

signal to the Vacuum Poppet Valve on and off. The toggling of the vacuum pilot signal on and off creates the air-economizing mode. When the vacuum level in system achieves the preset valve of P-1, the sensor output switches to a Closed, Passing, state. This activates the Air-Economizing valve which inhibits the vacuum pilot signal from creating vacuum. In nonporous applications, the internal check valve maintains the vacuum level till the level drops through the Hysterisis Range to the hysteresis switch point setting vacuum (P-2) minus (h-1). At this point, the sensor output switches to a open position, Non-passing state and de-activates the Air-Economizing Valve. This cycle will continue depending on the vacuum system and until blow-off function is enabled.

B

Air economizing

Minimizes air consumption by utilizing the built in check valve. Once a predetermined vacuum level has been achieved (P-1), the Air-Economizing valve is enabled and the check valve maintains the vacuum level within the system. The Air-Economizing valve is disabled at a vacuum level P-2 minus h-1. The hysteresis feature of the vacuum sensor can maintain the vacuum level of the system indefinitely when properly wired to the Air-Economizing valve and operating pressure is present.

Sensor Output 2 - Vacuum confirmation - part presence signal

Operates as an Output from the Sensor to provide a Part Presence Signal. This sensor output interfaces with the Input table on the PLC/PC. When the cup is adhered to the part, vacuum level increases and at the Switch Point Setting (H-2), the sensor changes state to indicate a part presence Signal.

Emergency stop condition

An emergency stop condition for factory automation is an external override condition that is usually activated by the machine operator to temporarily shut down the equipment. It is the Loss of Output Power or the Loss of Output Power and Input Power to the CVXCEK Vacuum Generator. The relevance to vacuum is the ability of the vacuum equipment to maintain the last output state of the control circuit.

The Emergency Operating System (EOS) on the CVXCEK unit is designed to maintain and continue the current operation mode of the vacuum generator. The detent Vacuum Pilot Valve will maintain the last command of the PLC/PC. The Air-economizing Valve will still operate during loss of output power. The current operation mode of the vacuum generator will be maintained when operating pressure is present.

If an emergency event or power failure occurs any time the system is in the shaded area, vacuum will be maintained to hold the work piece. If an emergency event or power failure occurs any time the system operations are at idle or during blow-off "ON", the system will remain or return to the idle state.

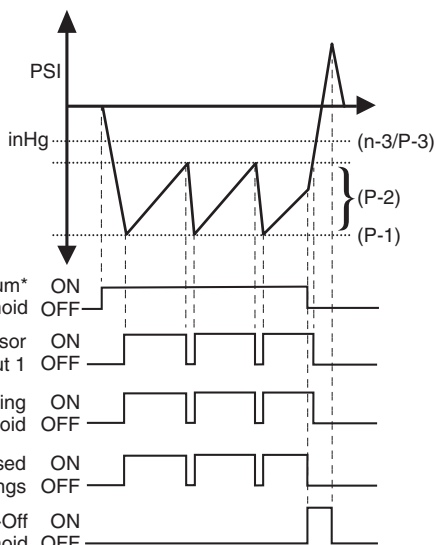

* Vacuum Solenoid can be a maintained or momentary signal. Maintained shown.

Sensor Output 1 - Air economizing

This sensor output does not interface with the input table of the PLC/PC. This sensor output interfaces with the Air-Economizing Valve on the CVXCEK Unit. The Vacuum Pilot Valve Solenoid is connected to the PLC/PC output table. The switch point setting, (P-1) on Output 1 of the sensor, enables the Air-Economizing Valve. No external PLC programming is required for Air-Economizing functions because this function is built into the CVXCEK Electrical Unit. The vacuum pilot signal from the vacuum ON/OFF valve is connected to the Air-Economizing Valve. It is this valve that toggles the vacuum pilot

Generator Selection	MCA, CV, CV-CK	
	CHF	
	MC22	
	MC72	
	CEK	
	CVXCEK	
	MPS-23	
	MVS-201	
	Generator Accessories	
		Glossary



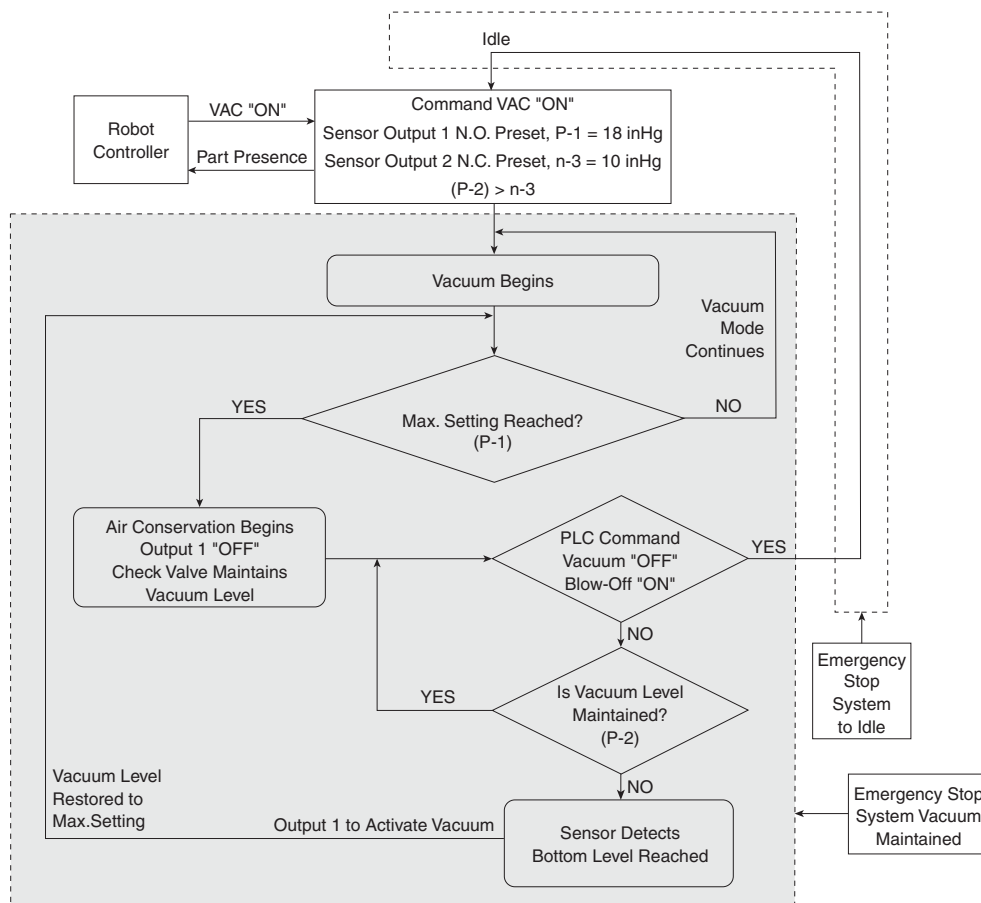

The Emergency Stop Operating System is designed to maintain the last state of operation when an emergency stop or power failure occurs.

The chart below illustrates the state of operation in different modes.

Modes	Vacuum on	Vacuum off	Blow-off
Normal Conditions	Air economizing 18 to 15.5 inHg	Idle	Blow-off on Blow-off idle
Emergency stop event			
Input power on Output power off	Air economizing 18 to 15.5 inHg	Idle	On → Idle Idle → Idle
Input power off Output power on	Vacuum on ↓ Max. vacuum on	Idle	On → Idle Idle → Idle
Input power off Output power off	Vacuum on ↓ Max. vacuum on	Idle	On → Idle Idle → Idle
Restore power Input power on Output power on	Vacuum on Air economizing 18 to 15.5 inHg	Idle	Idle

B
Generator Selection
MCA, CV, CV-GK
CHF
MC22
MC72
CEK
CVXCEK
MPS-23
MVS-201
Generator Accessories
Glossary



Dimensions

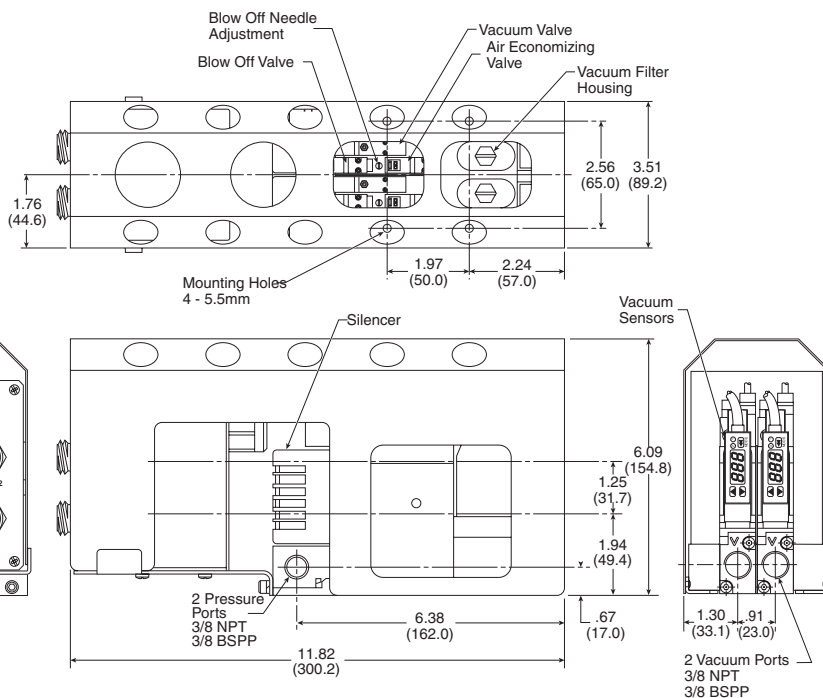

Optional mounting plate

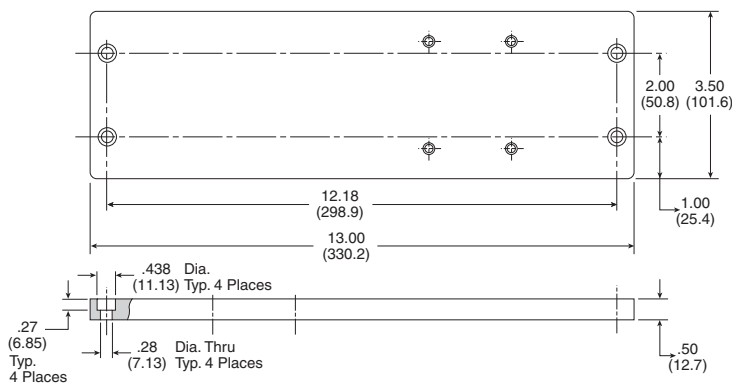

B	Generator Selection
	MCA, CV, CV-CK
	CHF
	MC22
	MC72
	CEK
	CVXCEK
	MPS-23
	MWS-201
	Generator Accessories
	Glossary

M12, 24VDC

Output - 4-Pin, M12, Keyed male

Input - 5-Pin, M12, Keyed male

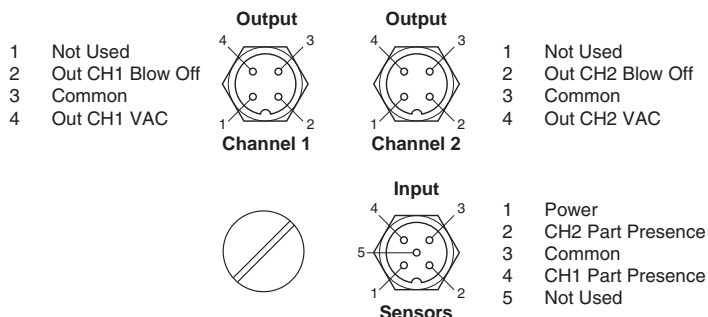

M12, 110VAC

Output - 4-Pin, M12, Double keyed male

Input - 5-Pin, M12, Double keyed male

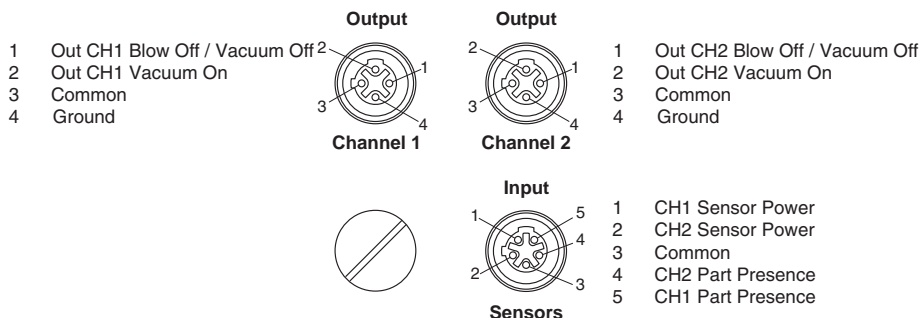

M18, 24VDC & 110VAC

18-Pin connector

24VDC

- A CH2 Blow Off
- B CH2 Sensor Power
- C CH2 Part Presence
- D CH2 VAC Control
- E CH1 Blow Off
- F CH1 Sensor Power
- G CH1 Part Presence
- H CH1 VAC Control
- J DC Voltage Monitor
- K Common
- L Ground
- M Not Used
- N Not Used
- P Output Power
- R Not Used
- S Not Used
- T Not Used
- U Not Used

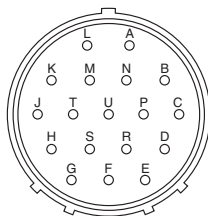

Face View - Male 18-Pin Connector

110VAC

- A CH2 Blow Off
- B CH2 Sensor Power
- C CH2 Part Presence
- D CH2 VAC Control
- E CH1 Blow Off
- F CH1 Sensor Power
- G CH1 Part Presence
- H CH1 VAC Control
- J AC Voltage Monitor
- K Common
- L Ground
- M Not Used
- N Not Used
- P Not Used
- R Not Used
- S Not Used
- T Output Power
- U Not Used

Notes: Pin B & F are jumpered inside unit.
Either pin can connect power to both sensors.

Pin P / T & J are jumpered inside unit.
This is for monitoring power only. Pin P / T is not necessary for operation of the unit.

B
Generator Selection
MCA, CV, CV-GK
CHF
MC22
MC72
CEK
CVXCEK
MPS-23
MVS-201
Generator Accessories
Glossary

Replacement components

Item	Part number	Description
1	CVK-S	Silencer
2 thru 7	CVK-F	Filter kit
5	CVK-E	Filter element
8	MC2-24-B-10-D	Blow-off pilot valve
9	MC2-24-A-10-V	Air-economizing valve
10	MC2-CB10	1000mm clip lead
11	PCL241B-NB-D24UM	Vacuum on / off valve, PNP
	VAO1PLC241PE	Vacuum on / off valve, NPN
12	PL1-CB10	1000mm clip lead
13	MPS-V23C-NC	Pressure sensor

B

Generator Selection

MCA, CV, CV-CK

CHF

MC22

MC72

CEK

CVXCEK

MPS-23

MWS-201

Generator Accessories

Glossary

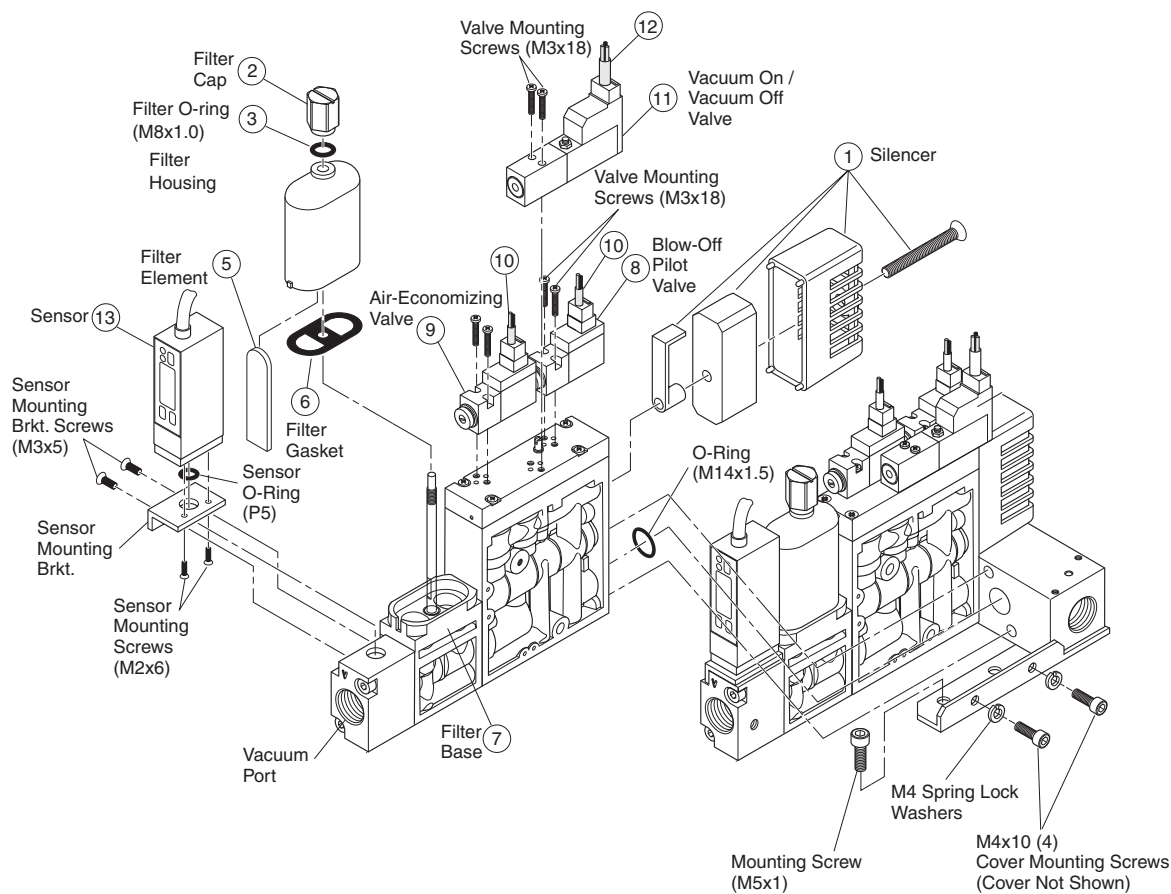

Discrete kits

PSCEKD1A - M12, 110VAC

PSCEKN1A - M18, 110VAC

PSCEKN3A - M18, 24VDC

PSCEKD3A - M12, 24VDC

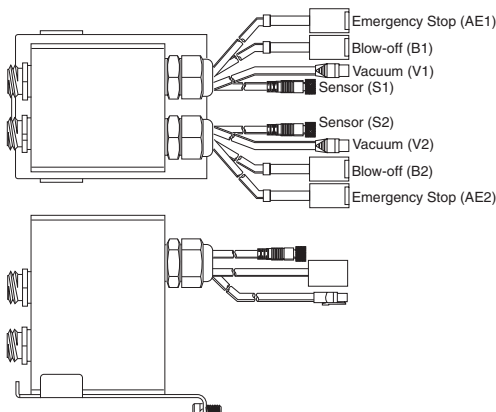
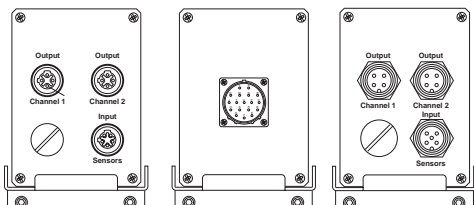

PL1-CB10, Valve cable

Black Wire, Solenoid B, vacuum off
 Red Wire, Common
 White Wire, Solenoid A, Vacuum on

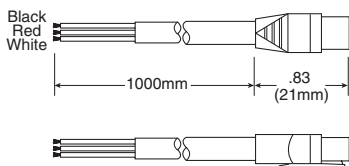

MC22-CB10 Valve Cable

(Connects Power Source to the Air-Economizing & Blow-off Release Pilot Valves)
 Positive "+" (Red Wire)
 Negative "-" (Black Wire)

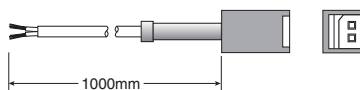

ENC244

Cover

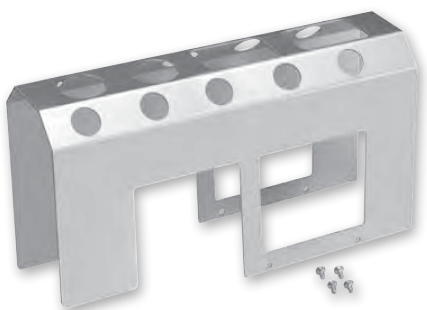

⚠ Cautions

Do not use or expose the CEK with fluids or corrosive gases. Vacuum Venturi's are designed to be used with non-lubricated, non-corrosive, compressed air.

Do not operate CEK generators outside the temperature range and pressures listed in the specifications section of this catalog. Regulate the compressed air to 70PSI and filtrate with a maximum 40 micron filter. Non-lubricated compressed air will maintain the life and vacuum level of the generator.

Check the insulation of all lead wires after installation to avoid shorts. Properly secure all lead wires to avoid stress or repeated movement that may fray lead wires.

Some electrical components are diode or zener diode protected. When installing solenoids and sensors, check the polarity of the component before applying power. Apply the appropriate voltage to the solenoids and sensors. Inappropriate voltage, shorts, or surges may damage the circuitry.

B
Generator Selection
MCA, CV, CV-GK
CHF
MC22
MC72
CEK
CVXCEK
MPS-23
MVS-201
Generator Accessories
Glossary

Features

- Pressure range:
 - Vacuum pressure: 0 to -30 inHg
- Sensor output:
 - 2 NPN or PNP open collector
 - Transistor output, 30VDC, 125mA
- Switch Point and Window Comparator Mode
- Selectable units of measure
- Output response time less than 2.0 milliseconds
- RoHS
- Air and non-corrosive gases
- Error message

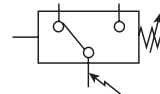
B

Generator Selection

MCA, CV, CV-CK

CHF

MC22

MC72

CEK

CVXCEK

MPS-23

MVS-201

Generator Accessories

Glossary

MPS-23 sensor only ordering numbers

Pressure range	Port thread	Electrical output	Electrical connection	Part number
0-30 inHg	Ejector mount	(2) PNP	M8 on 1M cable, 4-Pin	MPS-V23C-PC
0-30 inHg	Ejector mount	(2) NPN	M8 on 1M cable, 4-Pin	MPS-V23C-NC

MPS-23 Accessories

M8, 4-Pin, 2 meter cable	CB-M8-4P-2M-PUR
M8, 4-Pin, 5 meter cable	CB-M8-4P-5M-PUR

Sensor pin out
Pin #

- 1 Brown: 24VDC
- 2 White: PNP/NPN Open Collector Output 2
- 3 Blue: 0VDC
- 4 Black: PNP/NPN Open Collector Output 1

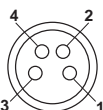
Programming options

Outputs change N.O. / N.C.	✓
Units of measure change	✓
Hysteresis mode	✓
Window comparator mode	✓
Auto teach mode	✓
Output response time	✓
Lockout option	—
Password lockout	✓
Max. value display	✓
Min. value display	✓
Zero reset	✓
Error output mode	✓

Internal circuit for open collector and analog output wiring

PNP Output

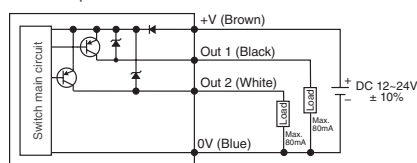

NPN Output

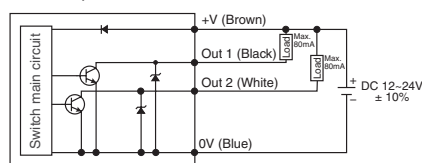

 Most popular.

B40

 Parker Hannifin Corporation
 Pneumatic Division
 Richland, Michigan
www.parker.com/pneumatics

Specifications

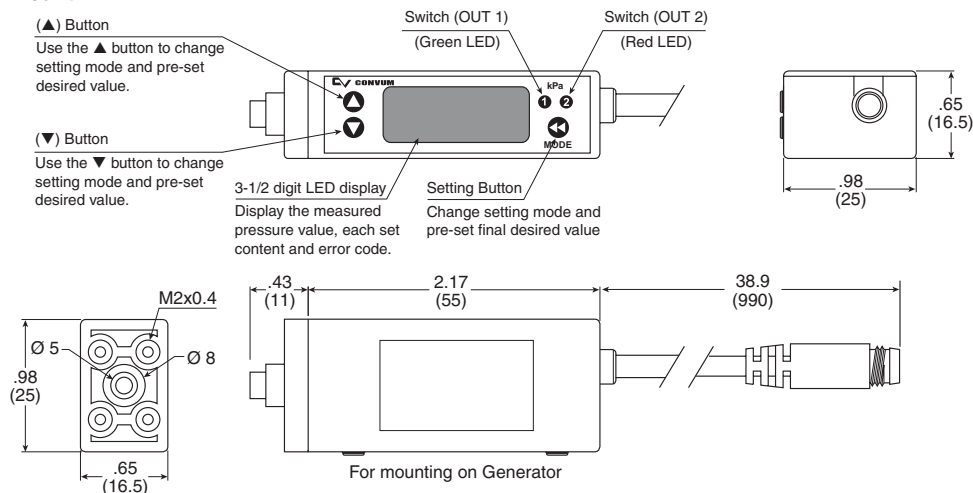
Pressure range	-101.3 - 0 kPa (-14.5 to 0 PSI)
Proof pressure	0.3 Mpa (44 PSI)
Display resolution, Units of measure	0.1, kPa
	0.001, kgf/cm ²
	0.001, bar
	0.01, PSI
	0.1, inHg
	1, mmHg
	0.1, mmH ₂ O
Media	Air & non-corrosive gases, incombustible gases
Pressure port	Generator mount only
Operating temperature	32 to 122°F (0 to 50°C)
Storage temperature	-4 to 140°F (-20 to 60°C)
Humidity	40 - 85% RH (no condensation)
Electrical connection	(C) 4-pin, M8 connector on 1M lead wire
Power supply	12 to 24VDC ±10% or less, Ripple (Vp-p) 10% or less
Display	3 + 1/2 digit, 1 color, 7-segment RED LED
Display refresh	.1 to 3.0 Seconds, Variable (factory set at 0.1)
Control output	NPN (Sinking), PNP (Sourcing), Open collector, max 80mA, 2 output
Switch output	Output signal, NPN or PNP, Normally open or closed, LED indicator
Output indicator	Green LED (OUT1), Red LED (OUT2)
Output modes	Hysteresis or Window Comparator
Response time	≤ 2.5ms (chattering-proof function: 24ms, 192ms, 786ms selections)
Repeatability	± 0.2% of F.S. ± 1 digit or less
Thermal error	≤ ± 2% of F.S. or less at range of 32 to 122°F (0 to 50°C)
General protection	IP40, CE marked, EMC-EN61000-6-2: 2001
Current consumption	<55mA
Vibration resistance	10 to 150Hz, Double amplitude 1.5mm, XYZ, 2 hrs.
Shock resistance	980 m/s ² (about 10G), 3 times/each directions X, Y, Z
Noise resistance	Vp-p400V, 10 ms, 0.5µs noise simulator
Material	Housing: ABS (black) , Pressure port: Zinc die-cast, Diaphragm: Silicone
Mass	2.5 oz. (80g) (including cable)

Dimensions
Generator mount

B

Generator Selection

MCA, CV, CV-GK

CHF

MC22

MC72

CEK

CVXCEK

MPS-23

MVS-201

Generator Accessories

Glossary

Initial setting mode

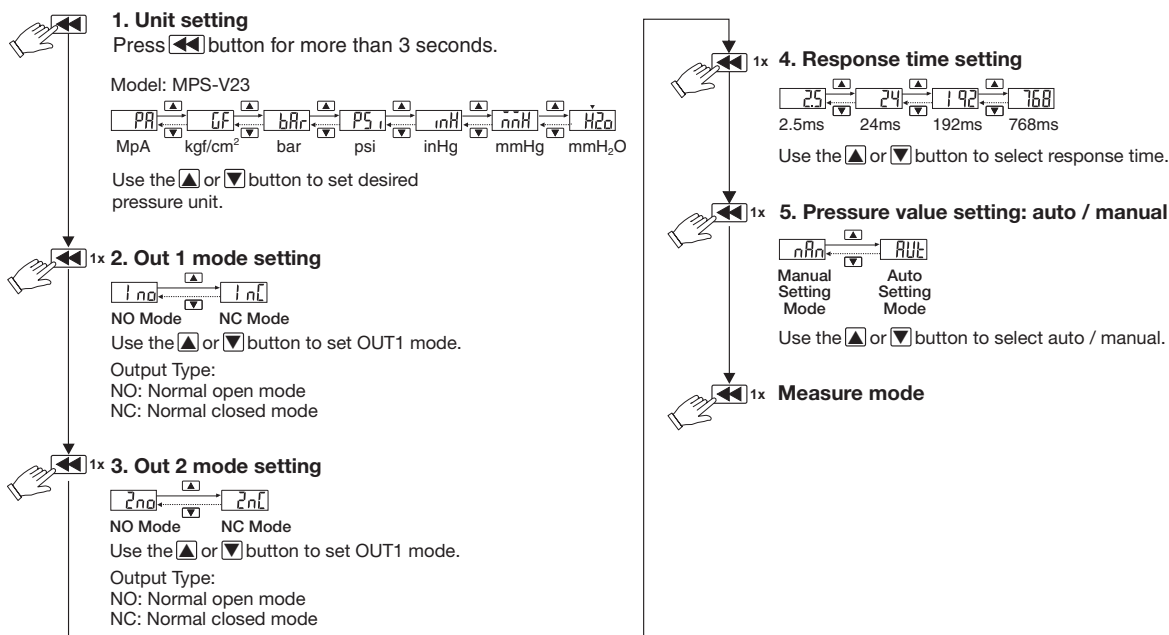

B	Generator Selection
	MCA, CV, CV-CK
	CHF
	MC22
	MC72
	CEK
	CVXCEK
	MPS-23
	MVS-201
	Generator Accessories
	Glossary

Zero point setting / the max. & min. display mode

Zero setting:

- press the button at the same time until the "00" is shown. Release the button to end zero setting.

The max. value display mode:

- Press button 2 seconds to enter the max. value mode, pressure sensor will detect the max. value and keep max. value displayed.
- Press button 2 seconds to return to measure mode display.

The min. value display mode:

- Press button 2 seconds to enter the min. value mode, pressure sensor will detect the min. value and keep min. value displayed.
- Press button 2 seconds to return to measure mode display.

Key lock / unlock mode

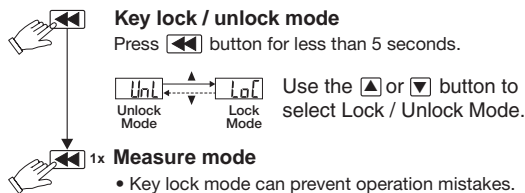

Output type

Hysteresis Mode $P_1 (n_1) > P_2 (n_2)$
 $P_3 (n_3) > P_4 (n_4)$
Output Hysteresis value can be preset.

Normal open mode

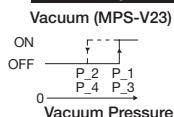

Normal close mode

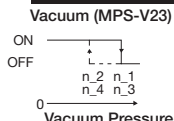

(Note)
When hysteresis mode setting is within 2 digits, if the input and pre-set pressure is quite near, pressure sensor output might cause chattering.

Window comparator Mode $P_1 (n_1) < P_2 (n_2)$
 $P_3 (n_3) < P_4 (n_4)$
Within pressure setting range, pressure sensor output can be ON or OFF.

Normal open mode

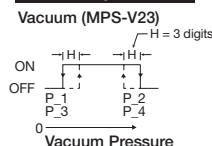

Normal close mode

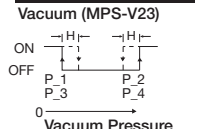

Manual setting mode

The LED shows: (P_*) at normal open mode and (n_*) at normal close mode. Pressure setting value is shown normally and will not lead to pressure sensor pause or stop working.

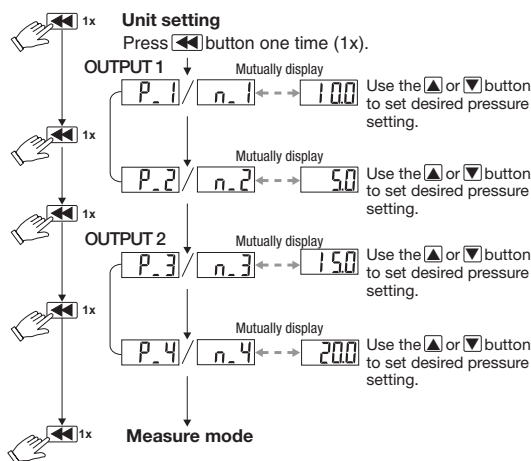

Auto setting mode

- *1. In case of without need of OUT1 pressure value setting, press $\nabla + \blacktriangle$ at the same time to enter (AP2) / (An2).
- *2. In case of without need of OUT2 pressure value setting, press $\nabla + \blacktriangle$ at the same time to enter measure mode.
- *3. The LED shows (AP*) at normal open mode and (An*) at normal closed mode.

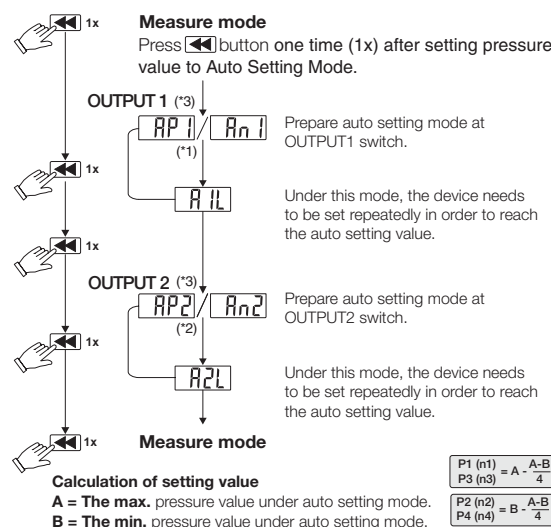

Calculation of setting value

$$P_1 (n_1) = \frac{A - B}{4}$$

$$P_3 (n_3) = \frac{A - B}{4}$$

A = The max. pressure value under auto setting mode.
B = The min. pressure value under auto setting mode.

Error messages

Error name	Display	Description	Solutions
Excess load current error	OUT1 Er1	Excess load current of 80 mA	Turn off power and check the cause of overload current or lower the current load under 80 mA, then restart
	OUT2 Er2		
Residual pressure error	Er3	During zero reset, ambient pressure is over $\pm 3\%$ F.S.	Change input pressure to ambient pressure and perform zero reset again
Applied pressure error	---	The applied pressure is excess the upper limit of pressure setting	Adjust the pressure within applied pressure range
	----	The applied pressure is excess the lower limit of pressure setting	
	Er4	Internal data error	
System Error	Er6	Internal system error	Turn power off and then restart. If error condition remains, please return to factory for inspection
	Er7	Internal data error	

B
Generator Selection
MCA, CV, CV-GK
CHF
MC22
MC72
CEK
CVXCEK
MPS-23
MVS-201
Generator Accessories
Glossary



Features
MVS-201 Genius

The MVS-201 is a winning combination with the MC2, CVR-2, and CVK vacuum generators. The MVS-201 automatically provides an output signal for the blow-off function without the need of an additional output from the PLC. Begin the vacuum cycle with an output signal from the PLC to the "201" sensor. The "201" sensor has one NPN or PNP output for vacuum confirmation and a control output that interfaces directly with the blow-off release pilot valve. With programmable time control features and a special chip driver, the sensor automatically activates the blow-off release when the NPN or PNP vacuum signal from the PLC is discontinued. This eliminates, THE PREVIOUSLY REQUIRED, PLC output to activate the blow-off release. This technology eliminates PLC output requirements by 50% and reduces installation to a simple 4 wire system by wiring the sensor only. There are 3 modes of operation for various applications. The output response time of the sensor is less than 2.5 msec. Peak limit prevention maintenance feature is automatically recorded internally.

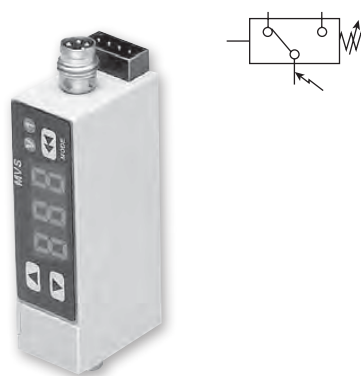
For use with MC22 / MC72 generators
Features

- Time controlled sensor
- Intelligent simple 4-wire system
- Eliminate I/O for release valve
- 2 functions with one rung of code
- Automatic timer (0-9.9 Sec.) function by sensor control driver for vacuum generating and release valves
- Peak value preventative maintenance confirmation
- Response time less than 2 milliseconds

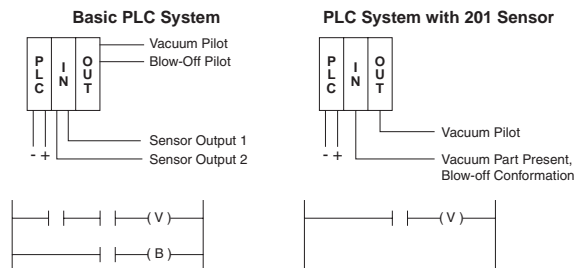
Programming options

Outputs change N.O. / N.C.	✓
Units of measure change	✓
Hysteresis mode	✓
Lockout option	✓
Zero reset	✓
Energy savings mode	✓
Air conservation / blow-off timer	✓
Vacuum timer option	✓
Signal controlled vacuum	✓
Blow-off activation timer	✓
Blow-off timer	✓
Vacuum confirmation signal	✓
Blow-off confirmation signal	✓
Peak vacuum error message	✓
Vacuum response error message	✓
Blow-off time error message	✓

MVS-201 Ordering numbers

Pressure range	Output circuit	Input circuit	Electrical connector *	Part number
-14.7 to 72.5 PSI	PNP sourcing	PNP sourcing	4 Pin, M8	MVS-201-PCP
	NPN sinking	NPN sinking		MVS-201-NC

* Requires sensor to valve electrical connector

Note:

Output Circuit provides vacuum and blow-off confirmation signal (Input Signal to PLC).
Input Circuit controls vacuum solenoid valve (Output Signal from PLC).

Sensor to valve electrical connector

Generator series	Sensor connection	Valve connection	Part number
MC22	5 Pin Clip Type	2 with clip type	MC22-C201G
MC72		2 wire leads	CVK-D201G

Most popular.



Specifications

Pressure range	Compound pressure: -14.7 to 72.5 PSI
Units of measure	bar: 0.01
Display resolution	kPa: 1
	kgf/cm ² : 0.01
	PSI: 0.1
Media	Non-lubricated air and non-corrosive gases
Proof pressure	116.0 PSI
Operating temperature	32 to 122°F (0 to 50°C)
Storage temperature	14 to 140°F (-10 to 60°C)
Humidity	35 to 85% RH
Electrical connection	4-Pin, M8 connector
Power supply	10.8 to 30VDC, Ripple Vp-p 10% Max., Reverse voltage protection
Display	3-Digit, 7-Segment LED
Display frequency	5Hz
Circuit	NPN (Sinking), PNP (Sourcing) open collector transistor
Digital output	Individually selectable N.O. or N.C., max 125mA, 30V, with overcurrent protection
Mode	OP1, OP2, OP3 hysteresis: 0 to 100% of switch point
Response time	< 2ms
Repeatability	± 0.3% F.S.
Thermal error	±0.2% F.S. in temperature range: 32 to 122°F (0 to 50°C)
General protection	IP40, CE marked, EMC-EN55011 Class B, EN50082-1
Current consumption	< 45mA, < 25mA when utilizing screen saver option
Spike protection	350 Vp, 1, μs
Dielectric strength	1000 VAC 1 min.
Insulation resistance	> 100M ohms at 500VDC
Vibration resistance	10 to 55Hz, 1.5mm, XYZ, 2 hrs.
Shock resistance	10 G, XYZ
Material	Body: Polycarbonate
Mass	1.7 oz. (45g)

B

 Generator
Selection

 MCA, CV,
CV-GK

CHF

MC22

MC72

CEK

CVXCEK

MPS-23

MVS-201

 Generator
Accessories

Glossary

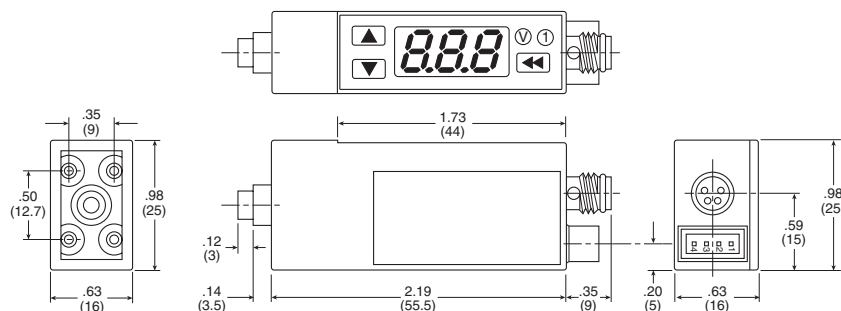
Dimensions
M8, 4-Pin

B45

 Parker Hannifin Corporation
Pneumatic Division
Richland, Michigan
www.parker.com/pneumatics

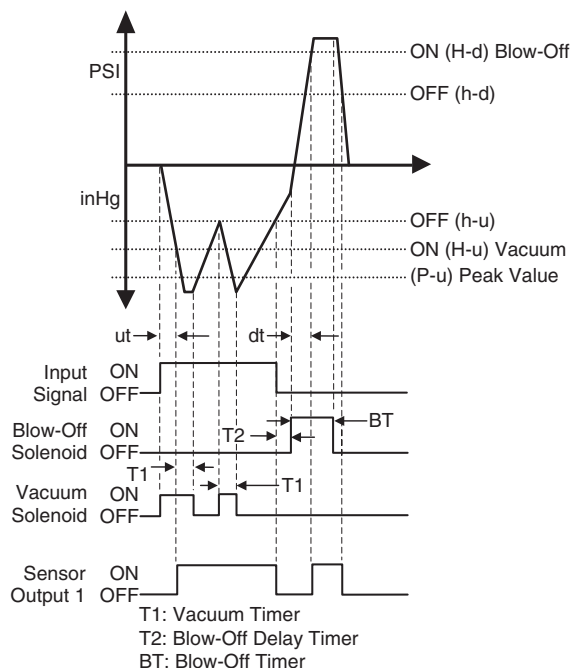
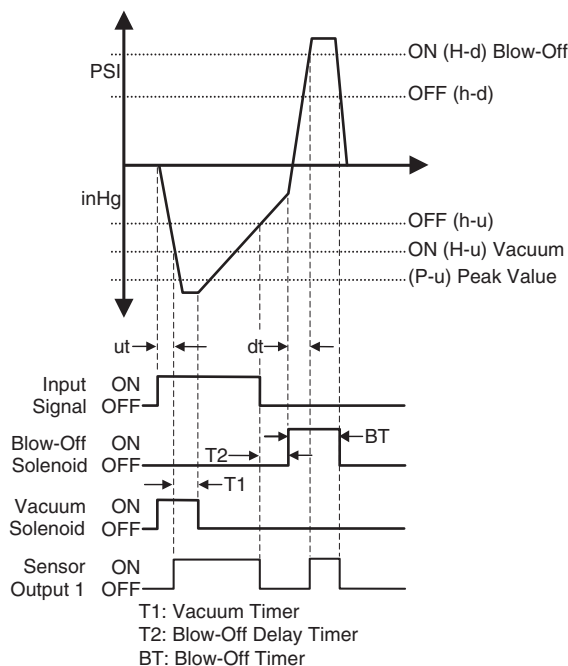
Operating modes
Mode: OP1 "Air Conservation / Timer"

Mode: OP2 "Vacuum Timer Option"

Timer mode OP1
"Air conservation / Vacuum valve timer"

This Vacuum valve control with the use of timing features conserves air consumption via the vacuum generator non-return check valve and sensor hysteresis function. Vacuum time (**t1**) can be used to control the vacuum valve for a specific length of time (0.0-9.9 sec.) after output 1 vacuum level is reached. The vacuum timing function (**t1**) will remove the signal from the sensor to the vacuum valve allowing the generator check valve system to conserve air consumption and vacuum. The vacuum valve will re-open for the same length of time (**t1**) when the pressure level drops to the hysteresis setting (**h-v**). The operation will continue until the input signal is stopped. Optional delay timer between vacuum / blow-off (**t2**) and blow-off (**bt**) timer is available. After selecting **OP1**, set **bt**, **t1**, and **t2** values by using arrow **"UP"** and **"DOWN"** keys. To bypass any of these timing function operations, simply enter 0.00 seconds and the sensor will automatically proceed to the next function.

Timer mode OP2
"Vacuum valve timer"

This mode is ideal for use with CONVUM generators without check valves. Vacuum timer (**t1**) can be used to control the vacuum for a specific length of time (0.00 – 9.9sec.) after output 1 is reached. Optional delay timer between vacuum / blow-off (**t2**) and blow-off (**bt**) timer is available. After selecting **OP2**, set **bt**, **t1**, and **t2** values by using arrow **"UP"** and **"DOWN"** keys. To bypass any of these timing function operations, simply enter 0.00 seconds and the sensor will automatically proceed to the next function.

Note:

Output Circuit provides vacuum and blow-off confirmation signal (Input Signal to PLC).
 Input Circuit controls vacuum solenoid valve (Output Signal from PLC).

Operating modes

Mode: OP3 "Signal Controlled Vacuum"

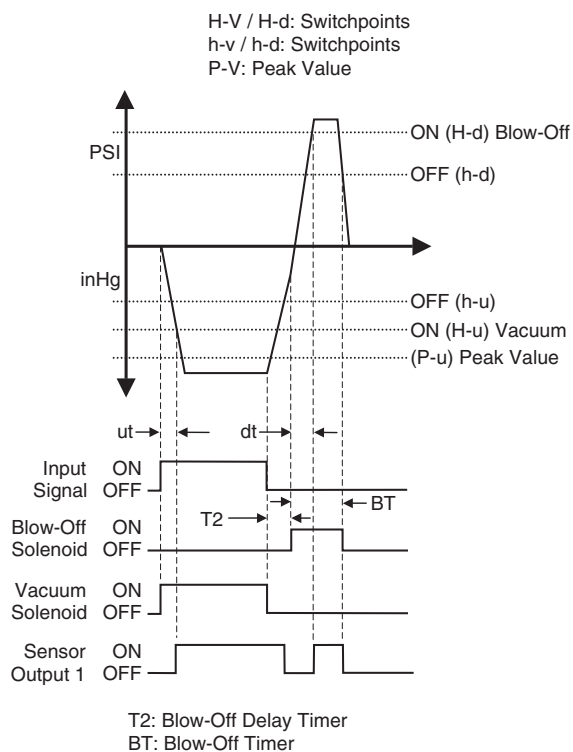

Timer mode OP3

"Signal controlled vacuum"

The vacuum timer option (t1) is omitted and the PLC controls the input signal time for the vacuum operation. The delay timer between vacuum / blow-off (t2) and the blow-off (bt) timers are still available. After selecting OP3, set bt and t2 values by using arrow "UP" and "DOWN" keys. To bypass any of these timing function operations, simply enter 0.00 seconds and the sensor will automatically proceed to the next function.

Note:

Output Circuit provides vacuum and blow-off confirmation signal (Input Signal to PLC).
Input Circuit controls vacuum solenoid valve (Output Signal from PLC).

Additional sensor features

(Available in all operating modes)

Screen saver function

This reduces current consumption by 20mA and will activate after 10 seconds.

Peak value level (P-v)



The sensor records this value for preventative maintenance issues. If this value is not reached the sensor will display an error message (ALP) indicating leaks or wear in the system.

Vacuum level response time (ut)



The sensor records the time (sec) to reach Output 1 and will display an error message (ALu) indicating Output 1 has not been reached within the acceptable time (sec) set by the user.

Blow-off time (dt)



The sensor records the time (sec) to complete blow-off cycle and will display an error message (ALd) indicating (dt) has not reacting within the acceptable time (sec) set by the user.

B

Generator Selection

MCA, CV, CV-GK

CHF

MC22

MC72

CEK

CVXCEK

MPS-23

MVS-201

Generator Accessories

Glossary



Wiring diagram
M8 Pin #

- 1 Brown: 24VDC
- 2 White: Input; NPN (0VDC) / PNP (24VDC)
- 3 Blue: 0VDC
- 4 Black: Output; NPN / PNP Open Collector Output

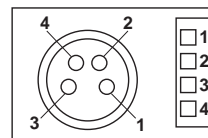
Sensor male pin out

201 Pin #

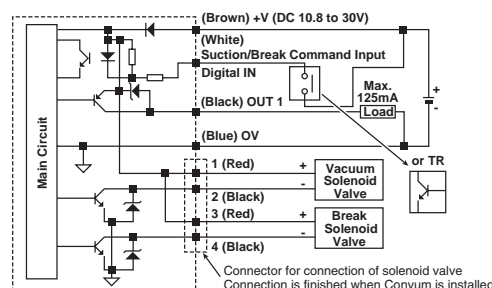
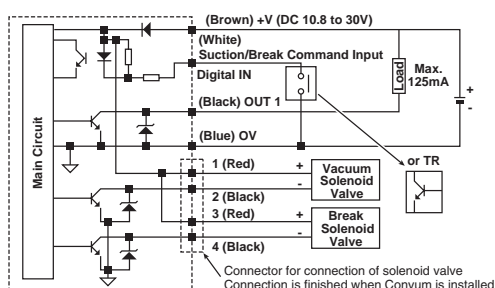
- 1 Red: Vacuum Solenoid Valve + V
- 2 Black: Gnd
- 3 Red: Blow-Off Solenoid Valve + V
- 4 Black: Gnd

Internal circuit

Output / Input NPN sinking
Output / Input PNP sourcing
Cautions

The MVS-201 Pressure Sensor is designed to monitor pressure and is not a safety measure to prevent accidents.

The compatibility of the sensor is the responsibility of the designer of the system and specifications.

Operating environment

- Parker Sensors have not been investigated for explosion-proof construction in hazardous environments.
- Do not use with flammable gases, liquids, or in hazardous environments.
- Avoid installing the sensor in locations where excessive voltage surges could damage or affect the performance of the sensor.

Operations

- Dedicate a power supply of 10.8 to 30VDC to the sensor and set the ripple to $V_p-p10\%$ or less. Avoid excessive voltage. Avoid voltage surges.
- A small amount of internal voltage drop is possible. Ensure the power supply minus any internal voltage drop exceeds the operating load.
- Verify the operating media is compatible with the specified sensor. Check the chemical make-up, operating temperatures, and maximum pressure ranges of the system before installing.
- Installation of air dryer system is recommended to remove moisture.

Installation

- Never insert an object into the pressure port other than an appropriate fluid connector.
- Avoid short-circuiting the sensor. Connect the brown lead to V+ and blue lead to 0V.
- Do not connect the output lead wires (black / white) to the power supply.
- Outputs not being used should be trimmed and insulated.

Error messages

Display	Description	Solutions
<i>Err</i>	Zero reset error	Reset zero below 3% of F.S.
<i>Er1</i>	System error (Internal)	Contact factory
<i>CE1</i>	Over current of Output 1	Load current exceeds maximum 125mA.
<i>FFF</i> <i>-FF</i>	Applied pressure exceeds pressure range	Apply pressures within the rating of the sensor



1 Press **1x**

Operating Mode 1

oP1 oP2
oP3

bt ↔ 200 999
000

t1 ↔ 030 300
000

t2 ↔ 000 999
000

End

Operating Mode 2

oP2 oP3
oP1

bt ↔ 200 999
000

t1 ↔ 030 300
000

t2 ↔ 000 999
000

End

Operating Mode 3

oP3 oP2
oP1

bt ↔ 999
000

t2 ↔ 999
000

End

2 Switch Output

H-u ↔ 46 0
100

h-u ↔ 7 0
100

H-d ↔ 000

h-d ↔ 000

End

3 Outmode Open or Closed

ou1 ↔ no nc

ouu ↔ no nc

oud ↔ no nc

Ed9 ↔ Lo Hi

PR bR F9 PS

End

Note: Ed9 setting Set to Lo for NPN Output Circuit or Hi for PNP Output Circuit.

4 Screen Saver Peak Vacuum Level Vacuum Level Response Time Blow-off Time

SdU ↔ off on

P-u ↔ off on 0
off

ut ↔ off on 999
off

dt ↔ off on 999
off

End

5 Hold **Lock** Press **Unlock**

Lock ↔ Unlock

Programming symbols legend

oP1	Operation 1: Air Conservation / Timer	ALd	Error Message - Blow-off Time
oP2	Operation 2: Vacuum Timer Option	ou1	Output 1
oP3	Operation 3: Signal Controlled Vacuum	ouu	Vacuum Valve (Leave NO)
bt	Blow-Off Timer	oud	Blow-off Release Valve (Leave NO)
t1	Controlled Vacuum Signal with Timer	SdU	Screen Saver Function
t2	Blow-Off Activation Timer	P-u	Peak Vacuum Level Recorder (P-v)
Hu	Switch Output Value (H-v)	ut	Vacuum Response Time Recorder
hu	Switch Output Hysteresis Value (h-v)	dt	Blow-Off Time Recorder
Hd	Blow-off Output Value (H-d)	no	Normally Open
hd	Blow-off Output Hysteresis Value (h-d)	nc	Normally Closed
ALP	Error Message - Peak Vacuum Level	Ed9	Low or High Signal to Vacuum Valve
ALu	Error Message - Vacuum Response Time		

B
Generator Selection
MCA, CV, CV-GK
CHF
MC22
MC72
CEK
CVXCEK
MPS-23
MVS-201
Generator Accessories
Glossary



Metered Flow Sensing Valve

Maintaining an acceptable level of vacuum is critical to the performance of vacuum systems that have a single source vacuum generator with multiple cups. The Parker Flow Sensing Valve assists in maintaining an acceptable vacuum level if the vacuum cup does not make a proper seal. The valve will automatically close if the cup loses the seal with the product during a pick and place motion.

The Parker Flow Sensing Valve is a normally open valve that switches to a closed metered state when the vacuum flow rate from the cup side to the generator side is greater than the switching flow rate of the flow sensing valve. The Flow Sensing Valve "Checks" the vacuum flow. The vacuum flow rate of the generator must be more than the switching flow rate of the Flow Sensing Valve or it will not switch to a "Checked" position.

When using multiple Flow Sensing Valves per generator, the flow rate of the generator must be more than the combined switching flow rates of the flow valves and any other leak path. For example, a CV20-HSN has a maximum flow rate of 3.88 SCFM and a 1/8 Flow Sensing Valve has a switching flow rate of 0.28 SCFM. Therefore 13 Flow Sensing Valves can be connected in parallel to a CV20-HSN.

Once a Flow Sensing Valve is "Checked", a small amount of by-pass flow occurs. This leakage allows a generator to be turned on prior to the cup being in place on a product and is the flow path used to evacuate the cup volume. The by-pass flow will decrease the maximum degree of vacuum in a system, and is considered a leak path when the cup is not sealed on a product. Blow off functions will still operate by forcing the Flow Sensing Valve to a full open position, allowing the part to be blown off.

Features

- Pick and place randomly placed products
- Minimize vacuum loss when cup seal is lost
- Direct mounting to cups
- 1/8 to G3/8 connection
- Integrated bronze filter

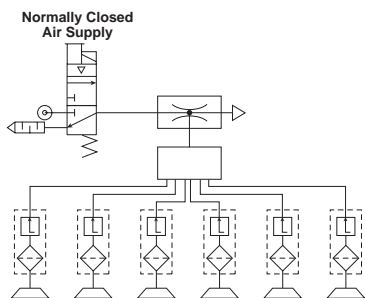

Ordering information

Description	Part number
1/8" BSPP	FSV-G1
1/4" BSPP	FSV-G2
3/8" BSPP	FSV-G3

Most popular.

Generator Accessories FSV Series – M5, G1, G2 & G3



Operation

When the flow of air from the cup side to the generator side is greater than the switching flow rate of the valve, the float is drawn back against the spring and seals on the housing. In this state, flow passes through an orifice on the float. Vacuum flow is "Checked". (See Figure 1).

When the cup comes in contact and seals on a product, flow is reduced and the spring forces the float towards the cup side inlet. This breaks the seal at the float and the full open state is restored. (See Figure 2).

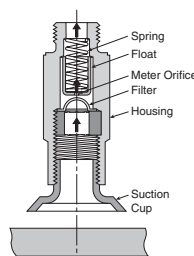

Figure 1
(Closed, Metered Flow)

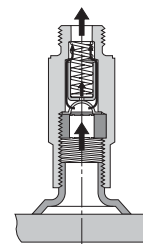
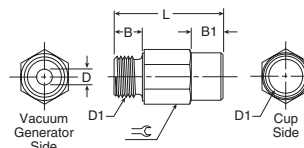

Figure 2
(Open, Full Flow)

Specifications

Description	FSV-G1	FSV-G2	FSV-G3
Switching flow rate	0.28 SCFM		0.875 SCFM
Nominal size	4mm		
Housing material	Anodized aluminum		
Filter material	Al-Niro mesh		
Temperature range	14° F to 140° F (-10° C to 60° C)		
Maximum pressure	145 PSI	115 PSI	
Media	Atmospheric air		
Weight (grams)	0.009	0.016	0.029



Dimensions

	B	B1	D	D1	L	⌀
FSV-G1	0.26 (6.5)	0.43 (11)	0.16 (4)	G	1.42 (36)	0.51 (13)
FSV-G2	0.33 (8.5)	0.43 (11)	0.16 (4)	G1/4	1.50 (38)	0.67 (17)
FSV-G3	0.47 (12)	0.51 (13)	0.16 (4)	G3/8	1.65 (42)	0.87 (22)

inches (mm)



B50

Parker Hannifin Corporation
Pneumatic Division
Richland, Michigan
www.parker.com/pneumatics

One Way Check Valve

Generator Accessories CH01 Series

The CH Check valve is used to hold a degree of vacuum downstream from the check valve when the vacuum generator upstream from the check valve is turned off. A separate blow-off connection downstream from the CH check valve is required to destroy the vacuum pressure and blow off the part.

This check valve is an open or passing flow path when there is a differential pressure from the pad side to the generator side.

Features

- Poppet design
- Low leakage
- Low cracking pressure

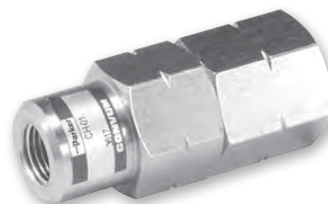

Normally Closed Air Supply
with Blow-off &
Optional Sensor

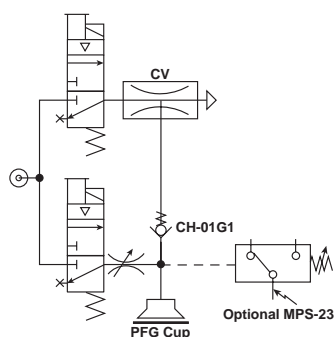

Ordering information

Description	Part number
BSPP Ports	CH-01G1
NPT Ports	CH-01N1

Specifications

Temperature range	32°F to 140°F (0° to 60°C)
Operating vacuum	-4.25 to -13.89 PSIG (-8.7 to -28.3 inHg)
Port size	Pad side = 1/4", Generator side = 1/8"
Leakage rate	0.2 PSI / minute (0.4 inHg / minute)
Cracking pressure	2.9 PSIG (5.9 inHg)

Materials

Valve body / Fittings	Brass / Aluminum
Seals	BUNA
Spring	SUS

Dimensions

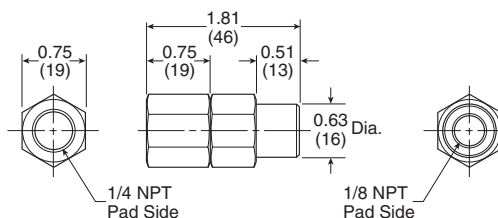

Most popular.



B
Generator Selection
MCA, CV, CV-GK
CHF
MC22
MC72
CEK
CVXCEK
MPS-23
MVS-201
Generator Accessories
Glossary

Ordering Information
**Generator Accessories
VF & VFL Series Filters**

Always filtrate the vacuum system to protect the components from damaging particles absorbed from the environment. Elements should be replaced periodically to prevent slower response and overall performance of the system.

B

Generator Selection

MCA, CV, CV-GK

CHF

MC22

MC72

CEK

CVXCIEK

MPS-23

MVS-201

Generator Accessories

Glossary

Specifications

Media	Non-corrosive air
Operating vacuum	0 to 28 inHg
Maximum pressure	60 PSI
Operating temperature	32 to 140°F
Filtration	120 µm (VF-2); 130 µm (VFL-44, 66, 88, VF-3, VF-5, VF-6)

Materials

Part number	Material housing	Material element	Weight (oz.)
VF-2G	Aluminum	Acrylic, Stainless steel	1.54
VF-3G	Aluminum	PC, Polyvinyl	3.10
VF-5G	Aluminum	PC, Polyvinyl	5.15
VF-6G	Aluminum	PC, Polyvinyl	8.25
VFL-44	Poly-carbonate	PC, Polyvinyl	0.67
VFL-66	Poly-carbonate	PC, Polyvinyl	0.74
VFL-88	Poly-carbonate	PC, Polyvinyl	0.81

Ordering information

Application	Male connection	Replacement elements	Replacement cover, o-ring	Part number
CV-05, CV-10	G1/8"	VF-2E	—	VF-2G
CV-05, CV-10	G1/8"	VF-3E	VF-3K	VF-3G
CV-15, MCA-10/13	G1/4"	VF-5E	VF-3K	VF-5G
CV-20/25/30	G3/8"	VF-6E	VF-3K	VF-6G
General use	4mm - Tube	VFL-E	VFL-44K	VFL-44
General use	6mm - Tube	VFL-E	VFL-66K	VFL-66
General use	8mm - Tube	VFL-88E	VFL-88K	VFL-88

 Most popular.

B52

Parker Hannifin Corporation
Pneumatic Division
Richland, Michigan
www.parker.com/pneumatics

Dimensions

VFL Series

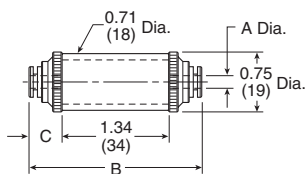

Part number	A	B	C
VFL-44	0.16 (4)	2.17 (55)	0.41 (10.5)
VFL-66	0.24 (6)	2.28 (58)	0.47 (12)
VFL-88	0.31 (8)	2.44 (62)	0.55 (14)

VF-5

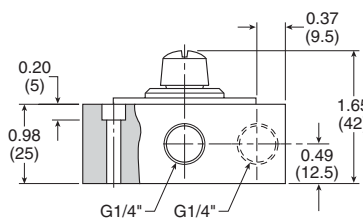

VFL-46H Mtg. Bracket

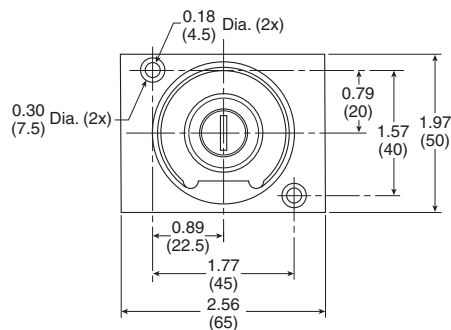
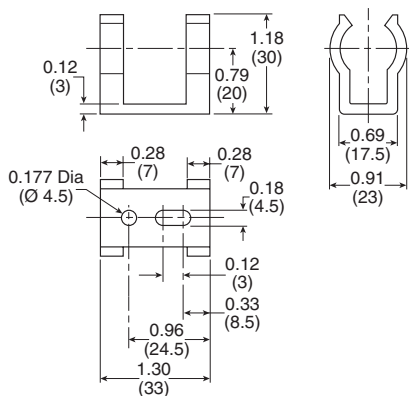

VF-2

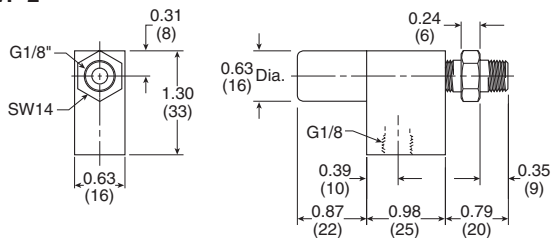

VF-6

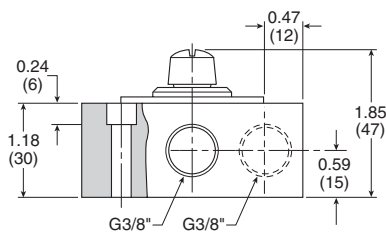

VF-3

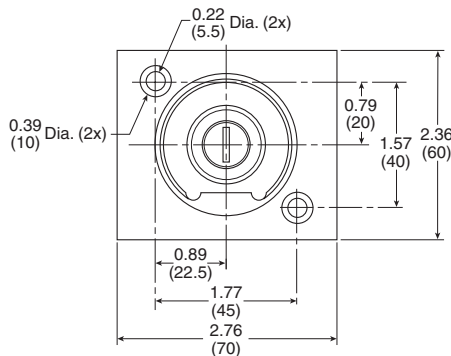
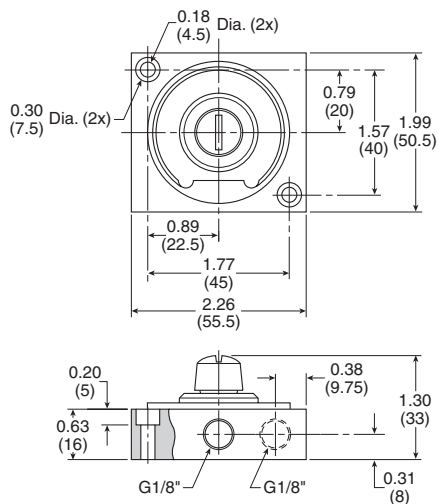

B
Generator Selection
MCA, CV, CV-GK
CHF
MC22
MC72
CEK
CVXCEK
MPS-23
MVS-201
Generator Accessories
Glossary



Ordering Information
VFP Series Filters

Parker plastic in-line filters provide easy monitoring, economy and safety. These shatterproof filters are airtight and can withstand high pressures.

A 10 micron porous plastic element prolongs element life under the most adverse environmental conditions.

Features

- To filter dust and other small particles from the vacuum flow
- Reduces the risk of operation breakdown or stoppage in the vacuum pump
- Replaceable filter element
- Made in the U.S.A.

Specifications

Media	Non-corrosive air
Operating vacuum range	-14.5 to 0 PSI (0 to 28 inHg)
Housing	Polypropylene (PP)
Material Bowl	Polyamide nylon (PA)
Filter element	Polyethylene (PE)
Temperature range	-4°F to 176°F (-20°C to 80°C)
Removal efficiency	10 µm
Maximum pressure	150 PSI

Ordering information

Port size	Flow SCFM*	Weight (oz)	Internal Volume in ³	Filter area in ²	Basic filter with element		Basic filter with 2 spare elements	
					NPT	BSPP	NPT	BSPP
1/8	25	1.7	2.10	4.9	VFP0CFC01	VFP0CFC11	VFP0CFC03	VFP0CFC13
1/4	35	1.98	2.4	4.9	VFP1CFC01	VFP1CFC11	VFP1CFC03	VFP1CFC13
3/8	45	2.47	2.7	4.9	VFP2CFC01	VFP2CFC11	VFP2CFC03	VFP2CFC13
1/2	130	6.61	11.9	16.0	VFP3CFC01	VFP3CFC11	VFP3CFC03	VFP3CFC13
3/4	175	6.42	12.5	16.0	VFP4CFC01	VFP4CFC11	VFP4CFC03	VFP4CFC13
1	290	15	30.2	29.5	VFP5CFC01	VFP5CFC11	VFP5CFC03	VFP5CFC13
1-1/2	430	18.80	41.2	35.0	VFP6CFC01	VFP6CFC11	VFP6CFC03	VFP6CFC13

* 90 PSIG inlet and 5 PSIG pressure drop

Most popular.

B

Generator Selection

MCA, CV, CV-CK

CHF

MC22

MC72

CEK

CVXCEK

MPS-23

MWS-201

Generator Accessories

Glossary

Model Number, Dimensions

VFP Series Filters

Dimensions

Part number	A	B	C	D	E
VFP0CFC*1	3.1 (78.7)	2.4 (61)	1.9 (48.3)	2.0 (50.8)	0.4 (10.2)
VFP1CFC*1	3.1 (78.7)	2.4 (61)	1.9 (48.3)	2.0 (50.8)	0.4 (10.2)
VFP2CFC*1	3.1 (78.7)	2.4 (61)	1.9 (48.3)	2.0 (50.8)	0.4 (10.2)
VFP3CFC*1	3.6 (91.4)	5.1 (129.5)	2.9 (73.6)	4.4 (111.6)	0.7 (17.8)
VFP4CFC*1	3.6 (91.4)	5.1 (129.5)	2.9 (73.6)	4.6 (116.9)	0.5 (12.7)
VFP5CFC*1	4.9 (124.5)	6.4 (162.6)	4.0 (101.6)	5.6 (142.2)	0.8 (20.3)
VFP6CFC*1	5.2 (132.1)	8.1 (209.9)	4.0 (101.6)	6.9 (175.3)	1.2 (30.5)

inches (mm)

* 0 (NPT), 1 (BSPP)

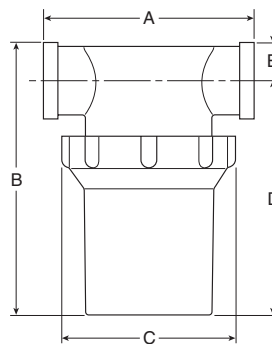

Replacement components

Part number	Size	Part number
Clear Bowl Kit (Includes O-ring)	1/8, 1/4, 3/8	PS577601
	1/2, 3/4	PS577602
	1, 1-1/2	PS577603
BUNA O-ring	1/8, 1/4, 3/8	PS577701
	1/2, 3/4	PS577702
	1, 1-1/2	PS577703
Filter Element Kit*	1/8	PS577801
	1/4	PS577801
	3/8	PS577801
	1/2	PS577802
Filter Element Kit*	3/4	PS577802
	1	PS577803
	1-1/2	PS577804

* All Filter Elements are sold as a 3-pack.

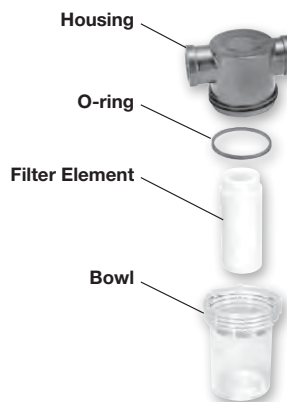

B

Generator Selection

MCA, CV, CV-GK

CHF

MC22

MC72

CEK

CVXCEK

MPS-23

MVS-201

Generator Accessories

Glossary

Ordering Information

Protect the environment against harmful noise levels with quality silencers.

Generator Accessories Silencers



B

Generator Selection

MCA, CV, CV-CK

CHF

MC22

MC72

CEK

CVXCIEK

MPS-23

MWS-201

Generator Accessories

Glossary

Ordering information

For generator series	Male connection	Part number
CV-05, CV-10	G1/8"	MSS-01
CV-05, CV-10	G1/8"	MSS-02
CV-15, MCA-10/13	G1/4"	MSM-01
CV-20	G1/2"	MSL-02
CV-25, CV-30	G3/4"	MS6-01

Specifications

Media	Non-corrosive air
Maximum pressure	128 PSI
Operating temperature	41 to 132°F
Silencing effect	20 dB

Materials

Material housing	Material element	Media	Weight (oz.)	Part number
Polyacetal	Felt, Urethane	Air	0.17	MSS-01
Polyacetal	Stainless steel	Oil	0.17	MSS-02
Polyurethane	Felt	Air	0.24	MSM-01
Nylon	Vinyl	Air	0.88	MSL-02
Nylon	Polyvinyl Forma	Air	2.01	MS6-01

Dimensions

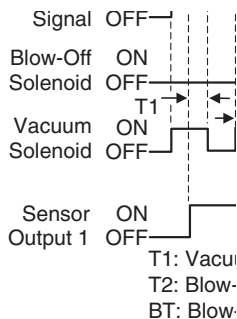

MSS-01

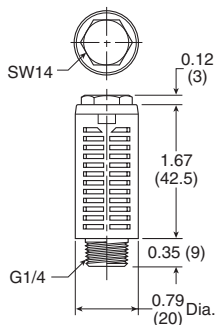

MSM-01

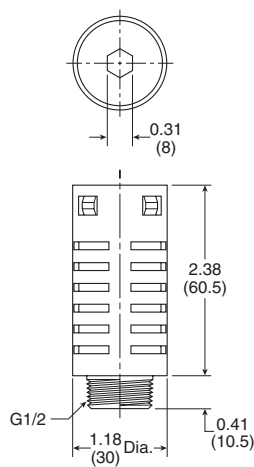

MSL-02

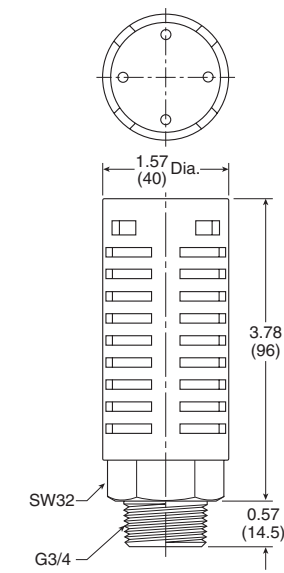

MS6-01

☐ Most popular.



Air Line Silencer – Plastic

The plastic silencer is designed to give excellent noise reduction with a minimum effect on air efficiency. The “Trimline” design allows for locating the silencer in the tightest places without extra plumbing or fittings. Fits directly into the exhaust port of most commercial valves. Open surface area of element allows for rapid discharge of air without undesirable back pressure.

Features

- Compact
- Lightweight
- Easy to install
- Excellent noise reduction
- Protects components from contamination
- NPT & BSPT threads available

Generator Accessories

ASN Series – M5, 1/8”, 1/4”, 3/8” & 1/2”



B

Specifications

Pressure rating	0 to 150 PSIG (0 to 10 bar, 0 to 1034 kPa)
Temperature rating	14°F to 140°F (-10°C to 60°C)

Materials

Body	Acetal (Plastic)
Element	Polyethylene

Ordering information, Dimensions

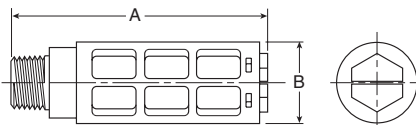

Thread size	A	B	Maximum flow (SCFM) 100 PSIG inlet	Sound pressure level (dBA)		Part number	
				20 PSIG inlet	100 PSIG inlet	NPT	BSPT
M5	0.43 (11)	0.32 (8)	15	69	79	AS-5	
1/8"	1.57 (40)	0.63 (16)	51	69	81	ASN-6	AS-6
1/4"	2.56 (65)	0.83 (21)	124	67	84	ASN-8	AS-8
3/8"	3.35 (85)	0.98 (25)	247	83	98	ASN-10	AS-10
1/2"	3.74 (95)	1.18 (30)	370	69	96	ASN-15	AS-15

inches (mm)

Most popular.



B57

Parker Hannifin Corporation
Pneumatic Division
Richland, Michigan
www.parker.com/pneumatics

Generator Selection

MCA, CV, CV-GK

CHF

MC22

MC72

CEK

CVXCEK

MPS-23

MVS-201

Generator Accessories

Glossary

Glossary
A
Air consumption

The amount of air in (measured in SCFM) consumed to achieve the maximum rated vacuum level of the venturi.

Air-economizing function

Integrated vacuum generators have the capacity to minimize air consumption by utilizing the built in check valve. Once a predetermined vacuum level has been achieved (with a non-porous application), the check valve can maintain the vacuum level within the system. The hysteresis feature of the vacuum sensor can maintain the vacuum level of the system indefinitely when properly wired to the vacuum solenoid pilot valve.

B
Blow-off needle

This is a flow adjustment supplied on integrated units to control the flow rate of the blow-off release.

Blow-off time

The amount of time required to break the vacuum and release the product in a pick and place application. This is signal controlled by the PLC or by the MVS-201 sensor.

Blow-off release master valve

This is a shuttle valve that works by differential forces which is piloted by a 2-3 valve. This valve is always configured normally closed.

E
Emergency stop

Emergency stop conditions for factory automation; this is an external override condition that is usually activated by the machine operator to temporarily shut the equipment down. The relevance to vacuum is the ability of the vacuum equipment to maintain the last output state of the control circuit. This feature would prevent part loss during this event as a normally closed system could maintain the current vacuum state without the presence of power.

F
Filtration

Filtration between the pad and generator is recommended. Regular maintenance of filters maintains the efficiency of the system.

I
Integrated vacuum generator

A vacuum venturi with integrated vacuum and blow-off release pilot valves built on the unit to minimize response times of the system. The unit may also incorporate filters, silencers, blow-off flow controls, and optional sensors.

L
Last output state

During an emergency stop or power loss event, emergency stop circuits from Parker can maintain the current state of operation. This is referred to as maintaining the last output state from the system controls.

P
Part present signal

Each sensor has an available NPN / PNP output and can be used for numerous purposes. One of them is a part present signal that usually signifies that a preset output for a vacuum level has been achieved and it is safe to proceed. The accuracy and repeatability of this signal can be critical to high speed applications. False or dropped signals can interrupt the systems operations. Therefore, stable vacuum levels and output settings near the "part-off" vacuum level are critical.

"Part-on" / "Part-off" vacuum differential

You must determine the highs and lows of the vacuum system in order to properly set the sensor outputs. Typically with venturi systems at fixed operating pressures, the maximum vacuum level is known. The "Part-off" vacuum level of the system must be determined by operating the system "open" while the sensor displays the level of vacuum in the system. This is known as the "Part/on" / "Part-off" differential in vacuum levels. Once this window of vacuum is known, the part present signal could be set in the middle between these vacuum levels. Ideally, it would be best if this window was as big as possible to avoid any issues with the sensors. Yet, sometimes by design or necessity, this window is very small or insignificant due to a high speed operation. To maximize the speed of the machinery, reduce the response time of the sensor output by setting the output around 1 inHg above the open vacuum level. The system response time is minimized and thus the "Part-on" / "Part-off" window is insignificant.

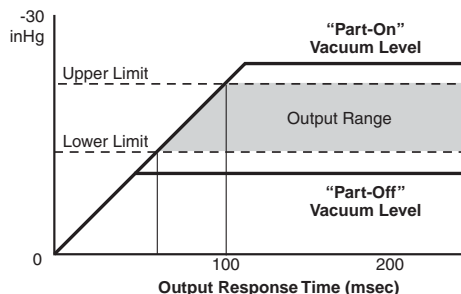
Power loss

This refers to loss of electrical power supply to the system. Unlike other pneumatic components with safety features, loss of electrical power to a normally closed vacuum circuit could be catastrophic; possibly resulting in dropping the product. To prevent this situation, consider an E-stop circuit or a normally open vacuum circuit.

B

Generator Selection

MCA, CV, CV-CK

CHF

MC22

MC72

CEK

CVXCEK

MPS-23

MVS-201

Generator Accessories

Glossary

Glossary

Pressure sensor

A piezo resistive sensor used to monitor pressure levels in the system. The sensors supply NPN/PNP open collector transistor outputs back to the PLC for confirmation.

__R__

Response time

The time to evacuate the air out of a closed system to a certain vacuum level. This is critical to the overall performance of the vacuum system.

__T__

Threads

- NPT (National Pipe Taper)
- BSPT (British Standard Pipe Taper)
- BSPP (British Standard Pipe Parallel)
- G (Gaus)
- M (Metric)
- NPS (Dry Seal American Standard Fuel Internal Straight Pipe)

__V__

Vacuum

Any reference to vacuum or negative pressures could be defined as a force applied to a closed system by the difference in the number of air molecules within a chamber, enclosure, piping system, etc. to the number of air molecules outside of these systems or enclosures. The outside atmospheric pressure is larger and applies a force to the lesser pressures in the systems or enclosures. Therefore, vacuum is a differential pressure whereby atmosphere is the reference and external force.

Vacuum confirmation

Term used to describe an output signal NPN/PNP from the sensor to the PLC when the suction cup has made a proper seal with the product before transfer. This verifies that the vacuum level is safe to proceed.

Vacuum flow

Represented as SCFM, this is the rate at which air molecules can be evacuated through a venturi system.

Vacuum generator

This is sometimes referred to as an ejector. The venturi generates vacuum with compressed air by evacuating air molecules from a closed system.

Vacuum release pilot valve

Also referred to as Discharge valve, this valve pilots the Blow-off release master valve to effectively release the product during pick and place applications. This function is essential to high speed applications.

Vacuum master valve

This is a shuttle valve that works by differential forces which is piloted by a 2-3 valve. This valve can be configured normally closed or open.

B
Generator Selection
MCA, CV, CV-GK
CHF
MC22
MC72
CEK
CVXCEK
MPS-23
MVS-201
Generator Accessories
Glossary



Notes

B

Generator Selection

MCA, CV, CV-CK

CHF

MC22

MC72

CEK

CVXCIEK

MPS-23

MVS-201

Generator Accessories

Glossary





Pressure Sensors

Section C

www.parker.com/pneu/sensors



C
Technical
MPS-37
MPS-34
SCP01
SCP5D
Accessories, Symbols, Glossary



Cautions



Cautions

Pressure sensors are designed to monitor pressure and are not a safety measure to prevent accidents.

The compatibility of the sensor is the responsibility of the designer of the system and specifications.

Operating environment

- Parker sensors have not been investigated for explosion-proof construction in hazardous environments.
- Do not use with flammable gases, liquids, or in hazardous environments.
- Avoid installing the sensor in locations where excessive voltage surges could damage or affect the performance of the sensor.

Operations

- Dedicate a power supply of 10.8 to 26.4VDC to the sensor and set the ripple to Vp-p10% or less. Avoid excessive voltage. Avoid voltage surges.
- A small amount of internal voltage drop is possible. Ensure the power supply minus any internal voltage drop exceeds the operating load.
- Verify the operating media is compatible with the specified sensor. Check the chemical make-up, operating temperatures, and maximum pressure ranges of the system before installing.
- Installation of air dryer system is recommended to remove moisture.

Pneumatic Control Components

Technical Data

Installation

- Never insert an object into the pressure port other than an appropriate fluid connector.
- Avoid short-circuiting the sensor. Connect the brown lead to V+ and blue lead to 0V.
- Do not connect the output lead wires (black / white) to the power supply.
- Outputs not being used should be trimmed and insulated.
- Install as shown using the metal mounting bracket.

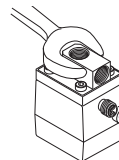

Technical





MPS-37

MPS-34

SCP01

SCP5D

Accessories,
Symbols,
Glossary

	Pressure range	Output type	Media	Maximum IP rating	Hysteresis output mode adjustment	Display	Page number
Technical data C4							
MPS-37							
	0 to -30 inHg -14.7 to 72.5 PSI 0 to 145 PSI	(2) NPN / PNP with 1-5VDC Analog	Air, Non-corrosive gas	65	Variable, 100% F.S.	LED display (Red)	C5 - C10
MPS-34							
	0 to -30 inHg 0 to 145 PSI	(1) PNP / NPN with 4 to 20ma Analog	Air, Non-corrosive gas	40	Variable, 100% F.S.	LED display (Red / Green)	C11 - C16
SCP01							
	-14.7 PSI to 150 PSI -14.7 PSI to 250 PS 0 to 1000 PSI 0 to 3000 PSI 0 to 5000 PSI 0 to 9000 PSI	4 to 20ma Analog	Non-corrosive to 316L SUS	67	—	—	C17 - C18
SCPSD							
	-14.7 PSI to 250 PSI 0 to 1000 PSI 0 to 2000 PSI 0 to 3000 PSI 0 to 5000 PSI 0 to 9000 PSI	(1 or 2) PNP Analog option	Non-corrosive to 316L SUS	67	Variable, 100% F.S.	LED display (Red)	C19 - C23
Accessories	Cables						C24
Glossary							C25 - C27

Programming options

Options	MPS 37	MPS 34	SPC01	SCPSD
Outputs change N.O. / N.C.	✓	✓	—	✓
Units of measure change	✓	✓	—	✓
Hysteresis mode	✓	✓	—	✓
Window comparator mode	✓	✓	—	✓
Auto teach mode	✓	✓	—	—
Output response time	✓	✓	—	✓
Lockout option	✓	✓	—	—
Password lockout	—	—	—	✓
Max. value display	✓	✓	—	—
Min. value display	✓	✓	—	—
Zero reset	✓	✓	—	✓
Red / Green LED display options	✓	✓	—	—
Error output mode	✓	✓	—	✓
Setting of decimal point	—	—	—	✓

C

Technical

MPS-37

MPS-34

SCP01

SCPSD

Accessories, Symbols, Glossary

Selecting the proper pressure sensor

Selecting a Parker Pressure Sensor for an application is more than just selecting the correct operating range of the sensor. Electromechanical pressure sensors convert the applied pressure to an electrical signal. When pressure is applied, the diaphragm is deflected causing the diffused resistors to change resistance (piezoelectric effect), which yields an electrical signal proportional to the pressure change. Applications for pressure switches are numerous and important in today's high-tech manufacturing environment. Parker Pressure Sensors are solid state sensors and not mechanical switches. The outputs are either analog (1 -5vc, 4-20ma or 0-20ma) or PNP/NPN

Open Collector Transistor Type Outputs. The application will determine if the Open Collector Output is used in a Hysteresis or Window Comparator Function. The output mode of the sensor, as well as whether the sensor is normally open (non-passing) or normally closed (passing), can be programmed by you to fit your application. In addition to electrical outputs, most of these sensors have additional programming options that can be integrated into the system logic for additional benefits. These programming options are listed at the bottom of the page and are detailed on the next pages. Choose the best Pressure Sensor for the application based on Pressure Range, Output Type and additional programming options.

Programming options:
Outputs change N.O. / N.C.

The status of the Output at 0 PSIG is either Normally Open (Non-Passing) or Normally Closed (Passing) and can be set through programming.

Units of measure

The units of measure on the display can be changed to suit the application. Some choices are PSI, inHg, Bar, Kpa, Mpa or mmHg and are dependent on the pressure range of the sensor.

Hysteresis mode

This output mode provides one switch point and a reversing point. When the switch point pressure is achieved, the output (NPN / PNP) changes state and will not change back until the reversing point pressure is achieved.

Window comparator mode

This output mode provides two switch points. These two points create a window that the sensor output holds its state (NO or NC). This mode is also referred to as High/Low Setting. Anytime the pressure is higher or lower than the "window" the output changes state.

Auto setting mode

Programming feature that automatically sets switch point and reversing points for the outputs of the sensor based upon the minimum and maximum pressure readings of the sensor over time.

Output response time

Output response time is the time it takes for the output signal to change state after the pressure switch point is achieved. Sensor response time is typically less than 2.0 milliseconds and can be made slower by programming the response time in multiples of the standard sensor response time.

Lockout option

All sensor programming is locked out. Programming or LED Display cannot be changed when the sensor is locked out.

Password lockout

Lockouts the sensor from any programming changes. To unlock the sensor a user programmed 4 digit code must be entered into the sensor.

Max. valve display

Sensor will only display the maximum applied pressure reading until reset to measuring mode. A helpful tool in system set up.

Min valve display

Sensor will only display the minimum applied pressure reading until reset to measuring mode. A helpful tool in system set up.

Zero reset

Just like a pressure gauge, a pressure sensor measures the system pressure in relation to the atmospheric pressure. Pressure Sensors can be calibrated to the current atmospheric pressure by using the Zero Reset Function.

Red / Green LED display options

Display LED's change from Red to Green, or Green to Red when the output changes state. This can be a great visual indicator on a plant floor.

Error output

Error Message is displayed if the pressures, inputs, or outputs exceed the parameters of the sensor

Setting of decimal point

Depending on the units of measure, the decimal point can be adjusted up to three decimal points. (SCPSD only)



Technical

MPS-37

MPS-34

SCP01

SCPSD

 Accessories,
Symbols,
Glossary

Features

- Sensor output:
 - 2 NPN or PNP open collector
 - Transistor output, 12-24 VAC, with
 - Analog output, 1 to 5 VDC
- Output response time less than 2.0 milliseconds
- RoHS
- Air and non-corrosive gas

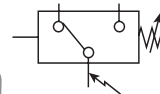

Programming options

Outputs change N.O. / N.C.	✓
Units of measure change	✓
Hysteresis mode	✓
Window comparator mode	✓
Auto teach mode	✓
Output response time	✓
Lockout option	✓
Password lockout	—
Max. value display	✓
Min. value display	✓
Zero reset	✓
Red / Green LED display options	✓
Error output mode	✓

MPS-37 Sensor only ordering numbers

Pressure range	Electrical output	Electrical connection	Part number	
			1/8 NPSF Female	1/8 BSPP Female
0-30 inHg	(2) PNP with (1) 1-5VDC	2M 5 Wire Lead Wire	MPS-V37N-PCA	MPS-V37G-PCA
0-30 inHg	(2) NPN with (1) 1-5VDC	2M 5 Wire Lead Wire	MPS-V37N-NCA	MPS-V37G-NCA
-14.5 to 72 PSI	(2) PNP with (1) 1-5VDC	2M 5 Wire Lead Wire	MPS-C37N-PCA	MPS-C37G-PCA
-14.5 to 72 PSI	(2) NPN with (1) 1-5VDC	2M 5 Wire Lead Wire	MPS-C37N-NCA	MPS-C37G-NCA
0-145 PSI	(2) PNP with (1) 1-5VDC	2M 5 Wire Lead Wire	MPS-P37N-PCA	MPS-P37G-PCA
0-145 PSI	(2) NPN with (1) 1-5VDC	2M 5 Wire Lead Wire	MPS-P37N-NCA	MPS-P37G-NCA

MPS-37 Accessories

Description	Part Number
Panel mounting bracket Note: Add "H" in suffix of Sensor Only Part Number to include with sensor	MPS-ACCH10
Surface mounting bracket Note: Add "K" in suffix of Sensor Only Part Number to include with sensor	MPS-ACCK14

Example: MPS-P37N-PGAK, includes sensor MPS-P37N-PGA with bracket MPS-ACCK14

Internal circuit for open collector and analog output wiring

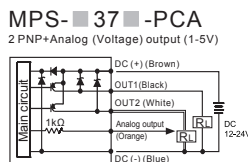
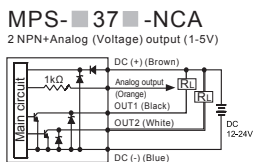

Lead Wiring

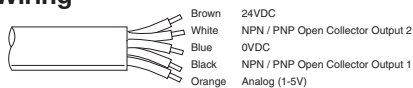

Most popular.



C

Technical

MPS-37

MPS-34

SCP01

SCP5D

Accessories, Symbols, Glossary

Specifications

	Vacuum (V)	Compound (R)	Positive (P)
Pressure range	-101.3 - 0 kPa (-14.5 to 0 PSI)	0 - 500 kPa (0 to 72 PSI)	-0.1 - 1 Mpa (0 to 145 PSI)
Proof pressure	0.3 Mpa (44 PSI)	0.8 Mpa (116 PSI)	1.5 Mpa (218 PSI)
Display resolution, Units of measure	0.1, kPa	1, kPa	0.001, Mpa
	0.001, kgf/cm ²	0.01, kgf/cm ²	0.01, kgf/cm ²
	0.001, bar	0.01, bar	0.01, bar
	0.01, PSI	0.1, PSI	0.1, PSI
	0.1, inHg	—	—
	1, mmHg	—	—
	0.1, mmH ₂ O	—	—
Media	Air & non-corrosive gases, incombustible gases		
Pressure port	(N) 1/8" NPSF, (G) 1/8" BSPP female		
Operating temperature	32 to 122°F (0 to 50°C)		
Storage temperature	-10 ~ 60°C (No condensation or freezing)		
Humidity	35 ~ 85% RH (No condensation)		
Electrical connection	Grommet open lead, 5 wire (0.15mm ²)		
Power supply	12 to 24VDC ±10% or less, Ripple (Vp-p) 10% or less		
Display	3½ digit, 7segment (red/ green)		
Display refresh	about .2 Seconds		
Control output	NPN or PNP open collector, 125 mA, 2 output		
Analog output	1 to 5VDC ≤ ±2.5% F.S. Linearity ≤1% of F.S.;		
Switch output	Output signal, NPN or PNP, Normally open or closed, LED indicator		
Output indicator	Orange (1 & 2 Indicator) OUT1 OUT2		
Output modes	Hysteresis or Window Comparator		
Response time	≤ 2.5 ms (chattering-proof function: 25ms, 100ms, 250ms, 500ms, 1000ms and 1500ms selections)		
Repeatability	± 0.2% of F.S. ± 1 digit or less		
Thermal error	≤ ± 2% of F.S. or less at range of 32 to 122°F (0 to 50°C)		
General protection	IP65, CE marked, EMC-EN61000-6-2: 2001, with dust tube connection		
Current consumption	≤ 40mA (with no load)		
Vibration resistance	10 to 150Hz, Double amplitude 1.5mm, XYZ, 2 hrs.		
Shock resistance	980 m/s ² (about 10G), 3 times/each directions X, Y, Z		
Noise resistance	Vp-p400V, 10 ms, 0.5µs noise simulator		
Material	Housing: ABS (white), Pressure port: Zinc die-cast, Diaphragm: Silicone		
Mass	4.4 oz. (125g) (including cable)		

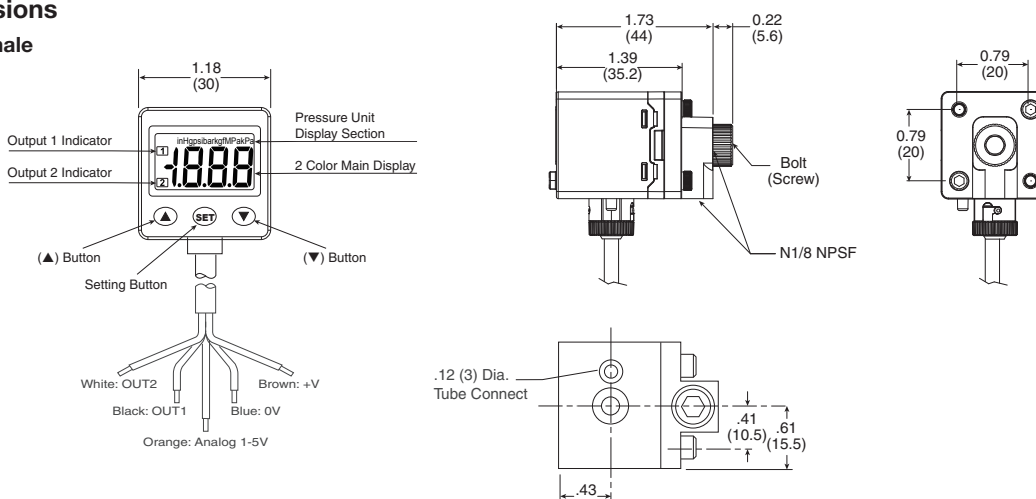
Dimensions
1/8" Female

MPS-ACCH10
Panel mounting
bracket

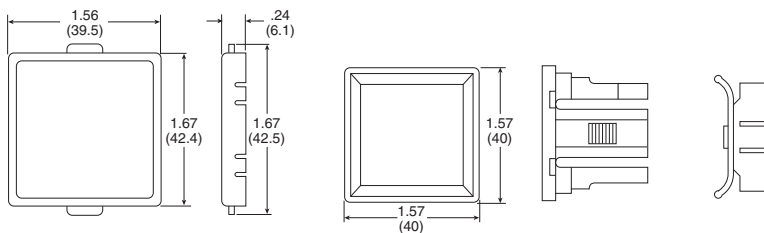
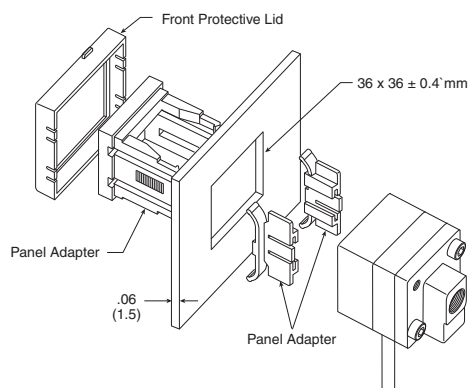

MPS-ACCK14
L3 & F3 mounting
brackets and
screws included

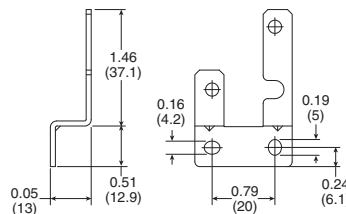
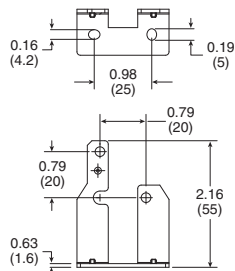
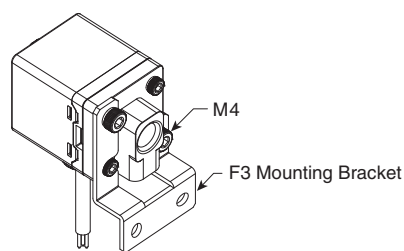
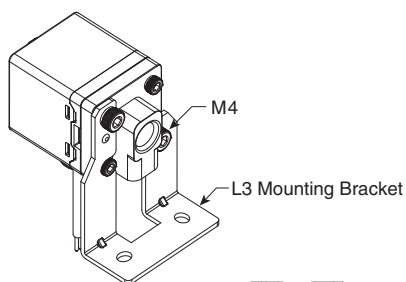

C
Technical
MPS-37
MPS-34
SCP01
SCP5D
Accessories, Symbols, Glossary

Initial Setting Mode

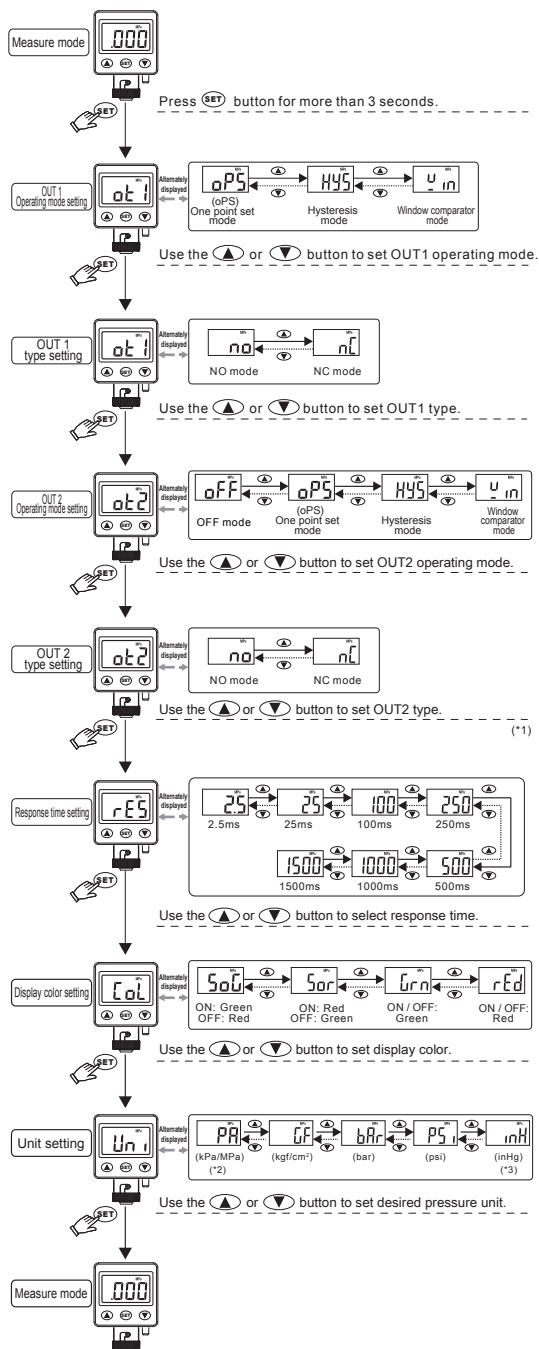

Note:

- *1. This setting mode will not display when output 2 is set to oFF.
- *2. Pressure unit is MPa with positive pressure.
Pressure unit is kPa with vacuum and compound pressure.
- *3. Only applicable for vacuum/compound.

Pressure Setting Mode

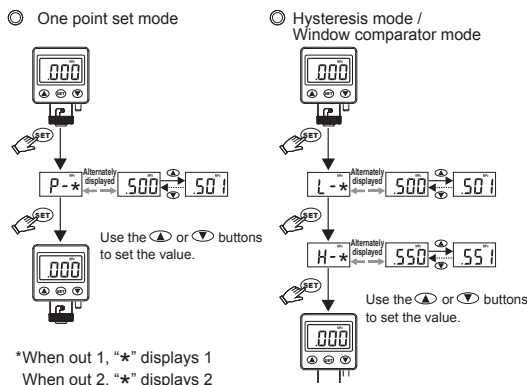

Output type

One point set mode

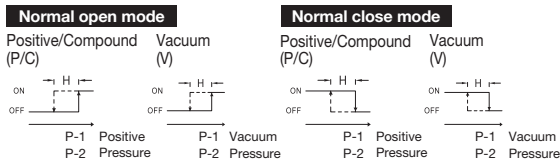

Hysteresis mode:

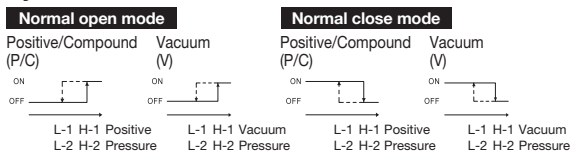

Window comparator mode:

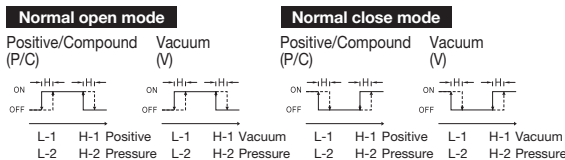

Note:

- *1. In case hysteresis is set at less than or equal to 2 digits, switch output may chatter if input pressure fluctuates near the set point.
- *2. When using window comparator mode, the difference between two set points must be greater than the fixed hysteresis, otherwise will cause the switch output to malfunction.

Technical
MPS-37
MPS-34
SCP01
SCP5D
Accessories,
Symbols,
Glossary

Programming Features

Advance Setting Mode

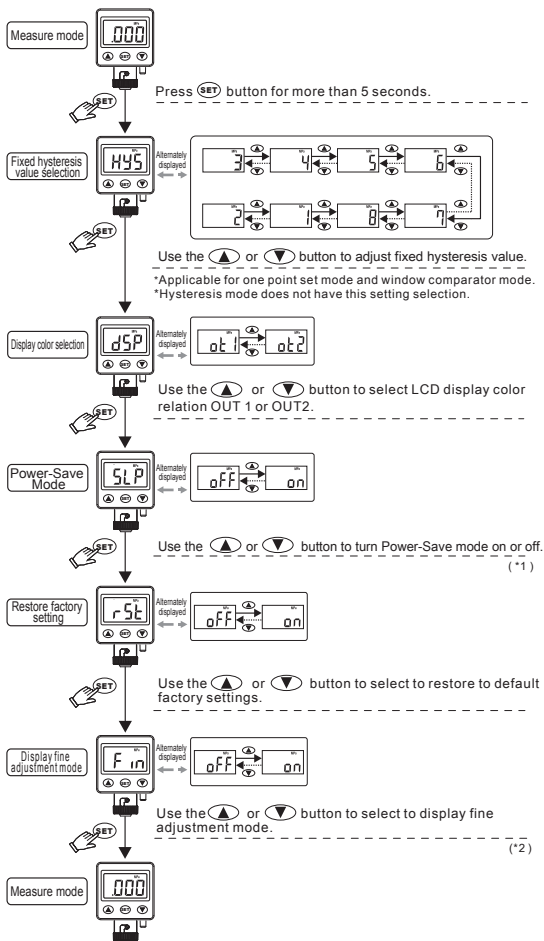

Note:

- *1. When setting is "[on]", the power-save mode is active. Please refer to Power-Saver Mode details.
- *2. When setting is "[on]", the display fine adjustment mode is active. Please refer to Fine Adjustment Mode details.

Power-Save Mode

- During Power-Save mode, the main display will turned off if no buttons are pressed after 30 seconds.
- During Power-Save mode, the output LCD may not be synchronize with the output. It is normal and will not affect output operation.
- Press any button to turn-on main display temporarily.

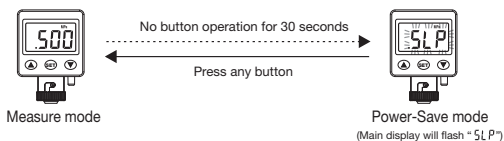

Zero Point Setting

Use the **▲** + **▼** button at the same time until the "00" is shown, Release the button to end zero setting.



Maximum and Minimum Display Mode

- Maximum value display mode: ○ Minimum value display mode:

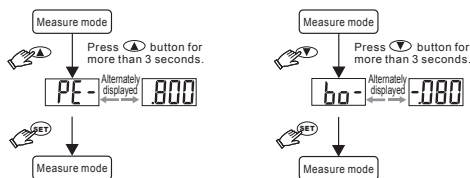

Key Lock/Unlock Mode

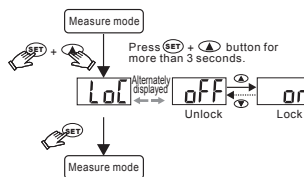

- Key lock mode, it displays as picture when pressing any key. After some time, it would be returned to measure mode.



Wire Installation Instruction

Please install the wire as the following step.

- Turn upward the salient point by terminal. (See figure ①)
- Install to the terminal to the groove by pressure sensor. (See figure ②)
- Terminal cover install to the products. (See figure ③)
- Turn the terminal cover to lock. (See figure ④)

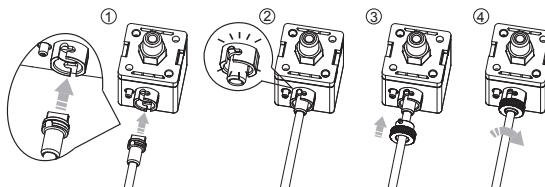

NOTE: Recommend not insert-extract over 20 times.

C	Technical
	MPS-37
	MPS-34
	SCP01
	SCP5D
	Accessories, Symbols, Glossary

Fine Adjustment Mode

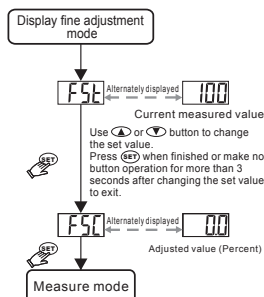

This function eliminates slight differences in the output values and allows uniformity in the numbers displayed. Displayed values of the pressure sensor can be calibrated to within $\pm 2.5\%$ R.D.

— :Factory setting display value set prior to shipment
— :Display calibration range

R.D. (Real Detect)

- NOTE: 1. Setting resolution is $\pm 0.1\%$ R.D.
2. The signal would be changed with analog output after adjusting

Analog Output Description

Analog output range 1 to 5V proportional to the pressure range.

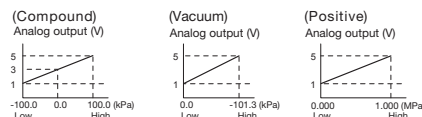

Technical
MPS-37
MPS-34
SCP01
SCP5D
Accessories, Symbols, Glossary

Error messages

Error name	Display	Description	Solutions
Excess load current error	OUT1 Er1	Excess load current of 125 mA	Turn off power and check the cause of overload current or lower the current load under 80 mA, then restart
	OUT2 Er2		
Residual pressure error	Er3	During zero reset, ambient pressure is over $\pm 3\%$ F.S.	Change input pressure to ambient pressure and perform zero reset again
Applied pressure error	HHH	The applied pressure is excess the upper limit of pressure setting	Adjust the pressure within applied pressure range
	LLL	The applied pressure is excess the lower limit of pressure setting	
System error	Er4	Internal data error	Turn power off and then restart. If error condition remains, please return to factory for inspection
	Er6	Internal system error	
	Er7	Internal data error	
Copy data error	Er8	Copy data error	Please check the model no. and wire connection. Retart to turn on power if no return to normal condition, please return to factory for inspection.



Features

- Sensor output:
 - 1 NPN or PNP Open collector
 - Transistor output, 30VDC, 125mA with
 - Analog output, 4 to 20mA
- Output response time less than 2.0 milliseconds
- RoHS
- Air and non-corrosive gases
- Sensor face includes icons to show sensor programming status

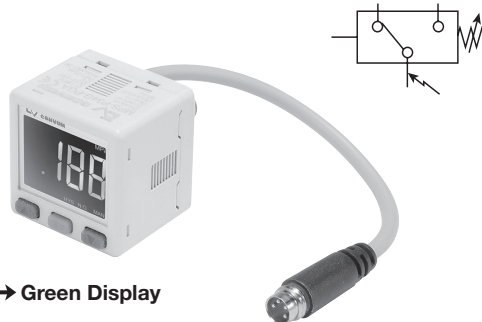

Red ↔ Green Display

Programming options

Outputs change N.O. / N.C.	✓
Units of measure change	✓
Hysteresis mode	✓
Window comparator mode	✓
Auto teach mode	✓
Output response time	✓
Lockout option	✓
Password lockout	—
Max. value display	✓
Min. value display	✓
Zero reset	✓
Red / Green LED display options	✓
Error output mode	✓

Sensor pin out with analog output

Pin #

- 1 Brown: 24VDC
- 2 White: 4 to 20mA
- 3 Blue: 0VDC
- 4 Black: PNP Open Collector Output 1

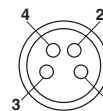

MPS-34 Sensor only ordering numbers

Pressure range	Electrical output	Electrical connection	Part number	
			1/8 NPSF male	1/8 BSPP male
0-30 inHg	(1) PNP with (1) 4-20ma	M8, 4 Pin	MPS-V34N-PCI	MPS-V34G-PCI
0-145 PSI	(1) PNP with (1) 4-20ma	M8, 4 Pin	MPS-P34N-PCI	MPS-P34G-PCI

MPS-34 Accessories

Description	Part number
Panel mounting bracket Note : Add "H" in suffix of Sensor Only Part Number to include with sensor	MPS-ACCH9
Surface mounting bracket Note : Add "K" in suffix of Sensor Only Part Number to include with sensor	MPS-ACCK10
Example: MPS-P34N-PCI K , includes sensor MPS-P34N-PCI with bracket MPS-ACCK10	
M8, 4-Pin, 2 meter cable	CB-M8-4P-2M-PUR
M8, 4-Pin, 5 meter cable	CB-M8-4P-5M-PUR

Internal circuit for open collector and analog output wiring

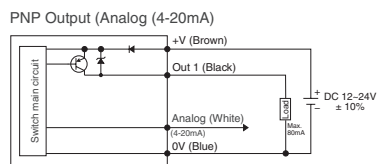

☐ Most popular.



C
Technical
MPS-37
MPS-34
SCP01
SCP5D
Accessories, Symbols, Glossary

Specifications

	Vacuum (V)	Positive (P)
Pressure range	-101.3 to 0 kPa (-14.5 to 0 PSI)	-0.1 to 1 Mpa (0 to 145 PSI)
Proof pressure	0.3 Mpa (44PSI)	1.5 Mpa (218 PSI)
Display resolution , Units of measure	0.1, kPa	1, kPa
	0.001, kgf/cm ²	0.01, kgf/cm ²
	0.001, bar	0.01, bar
	0.01, PSI	0.1, PSI
	0.01, inHg	-
	1, mmHg	-
Media	Air & non-corrosive gases	
Pressure port	(N) 1/8" NPT male, (G) 1/8 BSPP male both with M5 female port	
Operating temperature	32 to 122°F (0 to 50°C)	
Storage temperature	-4 to 140°F (-20 to 60°C)	
Humidity	35 to 85% RH (no condensation)	
Electrical connection	(C) 4-pin, M8 connector on 150mm lead wire	
Power supply	12 to 24VDC ±10%, Ripple (P-P) 10% or less	
Display	3 + 1/2 digit, 2 color, 7-segment RED / GREEN LED	
Display refresh	Timing update : 0.1 ~ 3 sec. (Factory Set Unit: 0.1 sec.)	
Switch output	Output signal, PNP, Normally open or closed, LED indicator, 125 mA max. output load	
Output modes	Hysteresis or Window Comparator	
Response time	≤ 2.5ms (chattering-proof function: 24ms, 250ms, 500ms, 1000ms and 1500ms selections)	
Repeatability	± 0.2% of F.S. ± 1 digit	
Output current	Output current 4 to 20mA; Linearity ±1.0% of F.S.; Maximum load impedance 300Ω at power supply of 12V; 600Ω at power supply of 12V; Minimum load impedance 50Ω	
Thermal error	32 to 122°F (0 to 50°C) 25°C (77°C) + 2% of F.S. or less at range of 32 to 122°F (0 to 50°C)	
General protection	IP40, CE marked, EMC-EN61000-6-2: 2001	
Current consumption	45mA (with no load)	
Vibration resistance	10 to 150Hz, Double amplitude 1.5mm, XYZ, 2 hrs.	
Shock resistance	980 m/s ² (about 10G), 3 times/each directions X, Y, Z	
Noise Resistance	Vp-p400V, 10 ms, 0.5μs noise simulator	
Material	Housing: ABS (gray) , Pressure port: Zinc die-cast, Diaphragm: Silicone	
Mass	1.45 oz. (45g) with M8 connector	

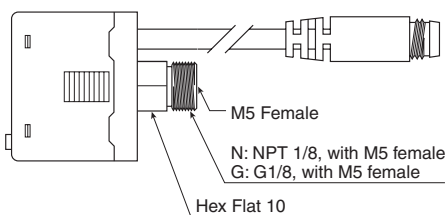
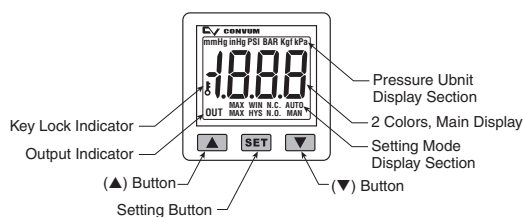
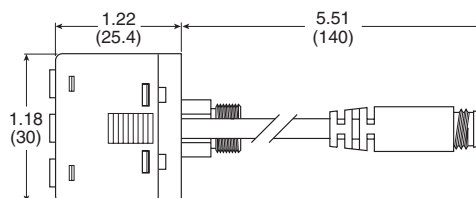
Dimensions
1/8" Male

Catalog 0802-E
Mounting Brackets

Pressure Sensors
MPS-34 2-Color Panel Mount

MPS-ACCH9
Panel mounting
bracket

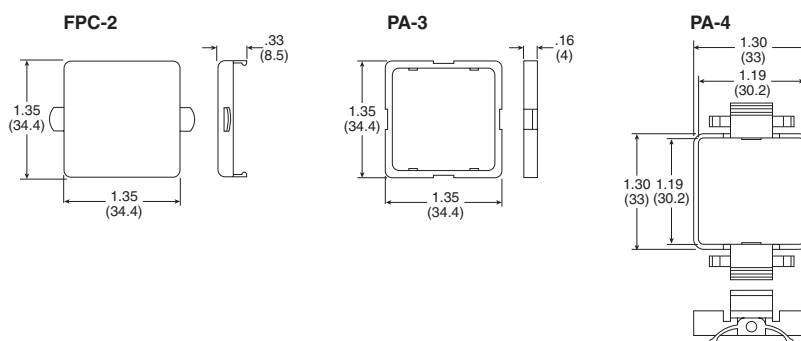
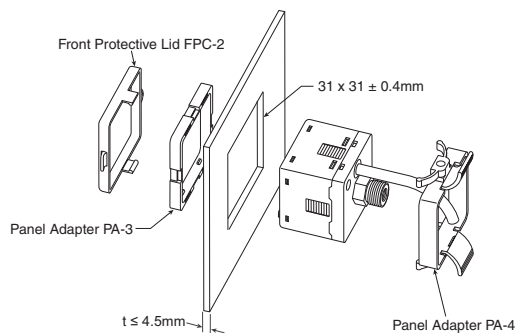

MPS-ACCK10
L3 & F3 mounting
brackets and
screws included

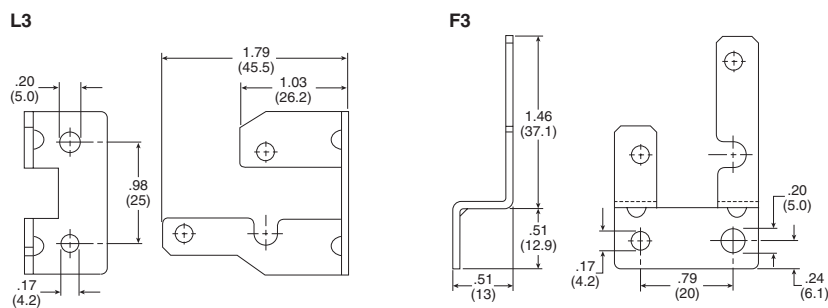
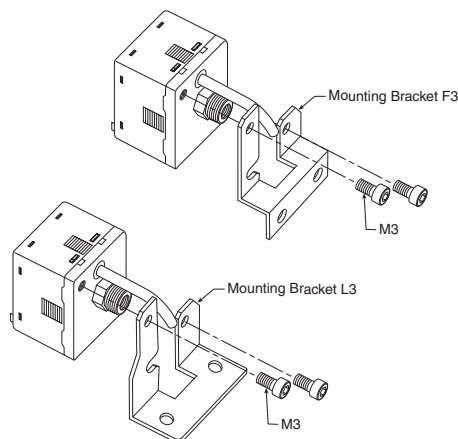

C
Technical
MPS-37
MPS-34
SCP01
SCP5D
Accessories, Symbols, Glossary

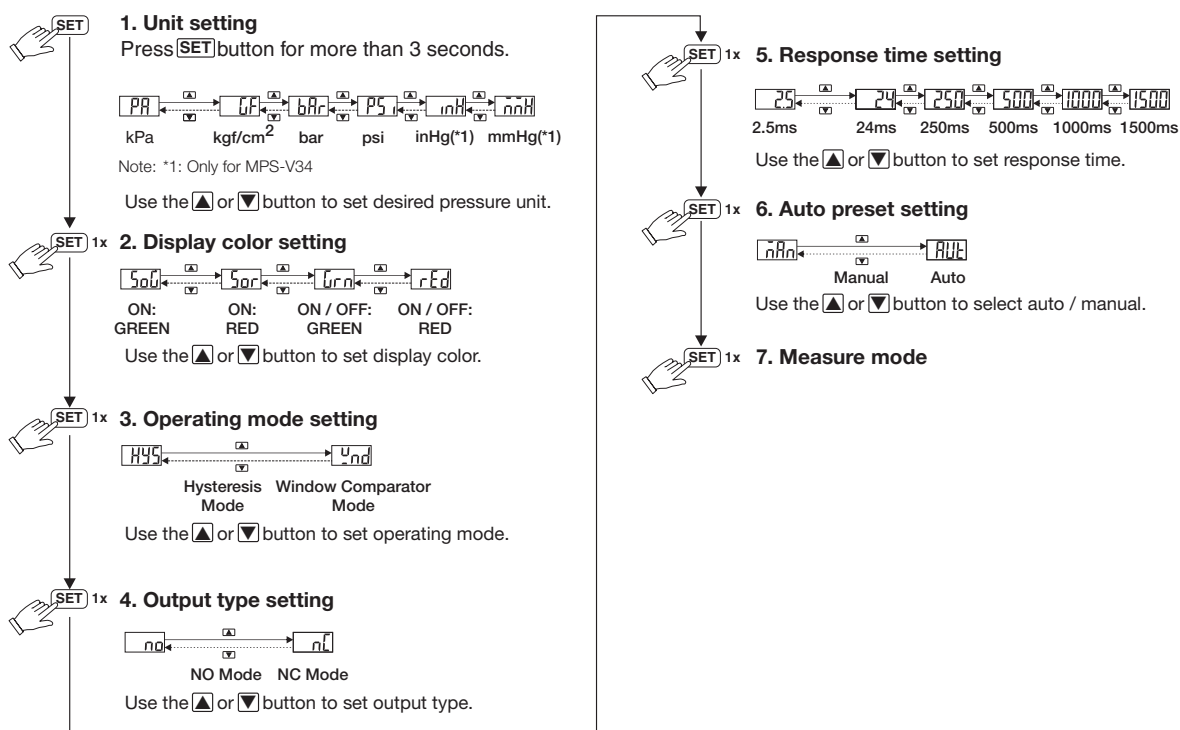

Initial setting mode

Zero point setting / the max. & min. display mode
Zero setting:

- press the button at the same time until the "00" is shown. Release the button to end zero setting.

The max. value display mode:

- Press button 2 seconds to enter the max. value mode, pressure sensor will detect the max. value and keep max. value displayed.
- Press button 2 seconds to return to measure mode display.

The min. value display mode:

- Press button 2 seconds to enter the min. value mode, pressure sensor will detect the min. value and keep min. value displayed.
- Press button 2 seconds to return to measure mode display.

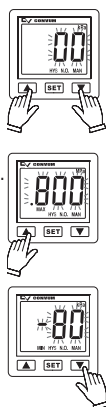
Key lock / unlock mode
Key lock / unlock mode

Press **SET** button for less than 5 seconds.

Unlock Mode Lock Mode

Use the or button to select Lock / Unlock Mode.

Measure mode

- Key lock mode can prevent operation mistakes.

Pressure setting mode

Hysteresis Mode

Output Hysteresis value can be preset.

Normal open mode

Positive (MPS-P34)

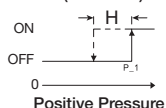

Vacuum (MPS-V34)

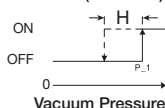

Normal close mode

Positive (MPS-P34)

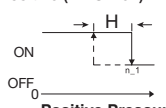

Vacuum (MPS-V34)

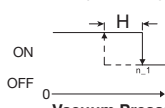

(Note)
 In case hysteresis is set at less than or equal to 2 digits, switch output may chatter if input pressure fluctuates near the set point.

Window comparator Mode

Within pressure setting range, pressure sensor output can be ON or OFF.

Normal open mode

Positive (MPS-P34)

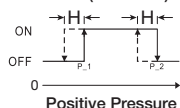

Vacuum (MPS-V34)

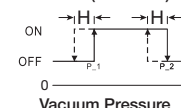

Normal close mode

Positive (MPS-P34)

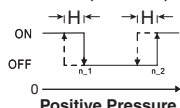

Vacuum (MPS-V34)

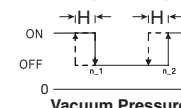

Manual setting mode

The LED shows: (P_*) at normal open mode and (n_*) at normal close mode. Pressure setting value is shown normally and will not lead to pressure sensor pause or stop working.

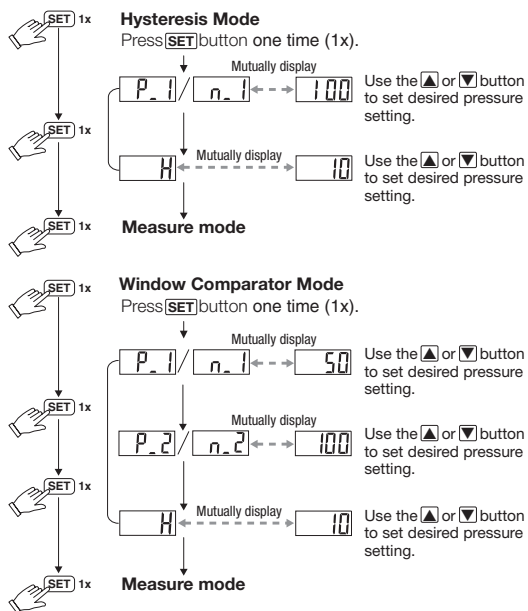

Auto setting mode

- The LED shows: (AP1) at normal open mode and (An1) at normal close mode.
- In case of without need of auto pressure value setting, press ▼+▲ at the same time to enter measure mode.

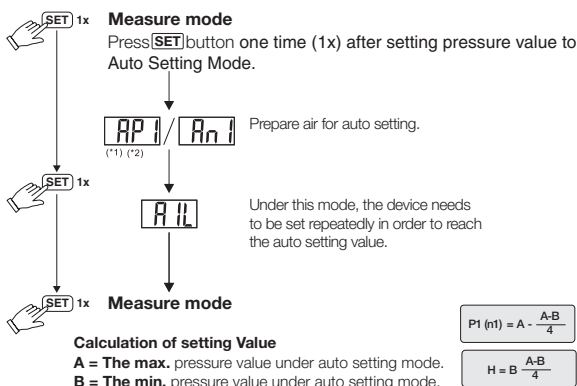

$$P1(n1) = A \cdot \frac{A-B}{4}$$

$$H = B \cdot \frac{A-B}{4}$$

Calculation of setting Value
A = The max. pressure value under auto setting mode.
B = The min. pressure value under auto setting mode.

C

Technical

MPS-37

MPS-34

SCP01

SCP5D

Accessories,
 Symbols,
 Glossary

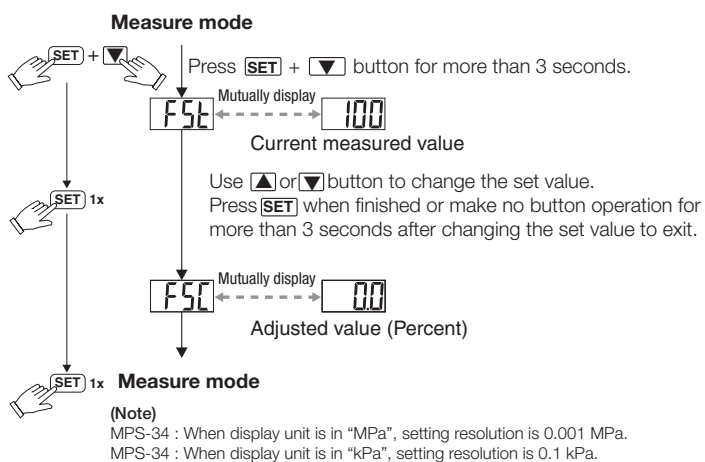
Fine adjustment mode

This function eliminates slight differences in the output values and allows uniformity in the numbers displayed. Displayed values of the pressure sensor can be calibrated to within $\pm 5\%$ for MPS-P34 and $\pm 2.5\%$ for series MPS-V34.

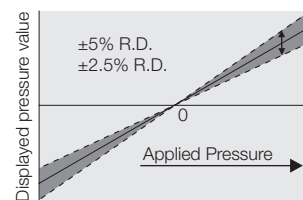

—: Factory setting display value set prior to shipment
■: Display calibration range

Error messages

Error name	Display	Description	Solutions
Excess load current error	<i>oCP</i>	Output load current of 125 mA	Turn off power and check the cause of overload current or lower the current load under 125 mA, then restart
Residual pressure error	<i>oUr</i>	During zero reset, ambient pressure is over $\pm 3\%$ F.S.	Change input pressure to ambient pressure and perform zero reset again
Applied pressure error	<i>HHH</i>	The applied pressure is excess the upper limit of pressure setting	Adjust the pressure within applied pressure range
	<i>LLL</i>	The applied pressure is excess the lower limit of pressure setting	
System Error	<i>Er4</i>	Internal data error	Turn power off and then restart. If error condition remains, please return to factory for inspection
	<i>Er6</i>	Internal system error	
	<i>Er7</i>	Internal data error	
	<i>Er8</i>	Internal system error	

Features, Ordering Information

SCP01 High Pressure 316 Stainless Steel

SCP01 Pressure Sensors are industrial pressure sensors offering long-term stability, resistance to interference and rugged construction. They are available in a wide range of standard and configured to order versions to meet your application needs.



These sensors are manufactured with the highest quality standards for reliable and repeatable measurements.

Features:

- Stainless steel body
- Compact construction
- Shock and vibration proof
- Resistant to pressure spikes
- Accuracy +/- 0.5% FS

Applications include:

- Test and measurement
- Hydraulic power units
- Power generation
- Mobile hydraulics

SCP01 Ordering numbers

Pressure range (psi)	Electrical output	Electrical connection	Part number	
			1/4 NPT male	7/16-20UNF-2A, male SAE-4 with o-ring
0 to 250	4 - 20 mA, 3 wire	M12 X 1, 4 pin	SCP01-0250P-25-07	SCP01-0250P-27-07
0 to 1000	4 - 20 mA, 3 wire	M12 X 1, 4 pin	SCP01-1000P-25-07	SCP01-1000P-27-07
0 to 3000	4 - 20 mA, 3 wire	M12 X 1, 4 pin	SCP01-3000P-25-07	SCP01-3000P-27-07
0 to 5000	4 - 20 mA, 3 wire	M12 X 1, 4 pin	SCP01-5000P-25-07	SCP01-5000P-27-07
0 to 9000	4 - 20 mA, 3 wire	M12 X 1, 4 pin	SCP01-9000P-25-07	N/A

Sensor pin out with analog output

Pin #

- 1 Supply
- 2 Signal output
- 3 Ground
- 4 —

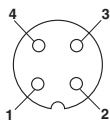

Most popular.



C
Technical
MPS-37
MPS-34
SCP01
SCP5D
Accessories, Symbols, Glossary

Specifications

Overload pressure	200% FS
Burst pressure	250% FS
Accuracy	+/- 0.5% FS
Protection class	IP67
Response time	< 1ms
Long term stability	< 0.1% FS/a
Load reversals	> 20 M
Electrical protection	Short circuit, reverse polarity, overload protection
Supply voltage	9-30VDC
Temperature range:	
Environmental	-40° F to 185° F
Media, storage	-40° F to 257° F
Compensated	-4° F to 185° F
Temperature coefficient	< +/- 0.3% FS/10K
Vibration resistance	Meets IEC 60068-2-29
Shock resistance	Meets IEC 60068 2-32
EMI compatibility	DIN EN 61000-6-3, DIN EN 61000-6-2
Material - housing	304 SS
Material - fitting	630 SS
Material - seal	Fluorocarbon
Sensing element	Thin film (poly Si on SiO ₂)
Pressure bore	0.024 in.
Long term stability	< 0.1% FS/a
Load reversals	> 20 M

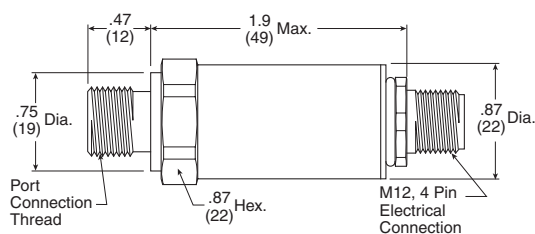
Dimensions

Features

- Stainless steel or ceramic diaphragms
- UL listed and CE marked
- Sensor outputs
 - 2 PNP Open collector transistor
 - Output, 30 VDC, 100mA
- Optional additional current, 4 to 20mA
- Output response time less than 5.0ms
- Polarity protected
- Short circuit protected
- 4 digit LED
- Display head swivels 290°

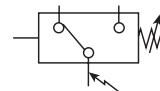
SCPSD-1000P-1727
Programming options

Outputs change N.O. / N.C.	✓
Units of measure change	✓
Hysteresis mode	✓
Window comparator mode	✓
Auto teach mode	—
Output response time	✓
Lockout option	—
Password lockout	✓
Max. value display	—
Min. value display	—
Zero reset	✓
Red / Green LED display options	—
Error output mode	✓
Setting of decimal point	✓



SCPSD-600-14-15
SCPSD Ordering numbers

Pressure range	Port size	Electrical output	Electrical connection	Part number
-14.7 to 250 PSI	7/16-20 UNF-2b (SAE-4)	(2) PNP	M12, 4 Pin	SCPSD-0250P-0727
-14.7 to 250 PSI	7/16-20 UNF-2b (SAE-4)	(1) PNP with 4-20MA	M12, 4 Pin	SCPSD-0250P-1727
0 to 1000 PSI	7/16-20 UNF-2b (SAE-4)	(2) PNP with 4-20MA	M12, 5 Pin	SCPSD-1000P-1725
0 to 1000 PSI	7/16-20 UNF-2b (SAE-4)	(1) PNP with 4-20MA	M12, 4 Pin	SCPSD-1000P-1727
0 to 3000 PSI	7/16-20 UNF-2b (SAE-4)	(2) PNP	M12, 4 Pin	SCPSD-3000P-0727
0 to 3000 PSI	7/16-20 UNF-2b (SAE-4)	(1) PNP with 4-20MA	M12, 4 Pin	SCPSD-3000P-1727
0 to 3000 PSI	7/16-20 UNF-2b (SAE-4)	(2) PNP with 4-20MA	M12, 5 Pin	SCPSD-3000P-1725
0 to 5000 PSI	7/16-20 UNF-2b (SAE-4)	(1) PNP with 4-20MA	M12, 4 Pin	SCPSD-5000P-1727
0 to 5000 PSI	7/16-20 UNF-2b (SAE-4)	(2) PNP with 4-20MA	M12, 5 Pin	SCPSD-5000P-1725
0 to 9000 PSI	7/16-20 UNF-2b (SAE-4)	(2) PNP	M12, 4 Pin	SCPSD-9000P-0727
0 to 9000 PSI	7/16-20 UNF-2b (SAE-4)	(2) PNP with 4-20MA	M12, 4 Pin	SCPSD-9000P-1725
-1 to 16 Bar	1/4 BSPP Male	(2) PNP	M12, 4 Pin	SCPSD-016-04-17
-1 to 16 Bar	1/4 BSPP Male	(2) PNP with 4-20ma	M12, 5 Pin	SCPSD-016-14-15
0 to 250 Bar	1/4 BSPP Male	(2) PNP	M12, 4 Pin	SCPSD-250-04-17
0 to 250 Bar	1/4 BSPP Male	(2) PNP with 4-20ma	M12, 5 Pin	SCPSD-250-14-15
0 to 600 Bar	1/4 BSPP Male	(2) PNP	M12, 4 Pin	SCPSD-600-04-17
0 to 600 Bar	1/4 BSPP Male	(2) PNP with 4-20ma	M12, 5 Pin	SCPSD-600-14-15

 Most popular.

Specifications

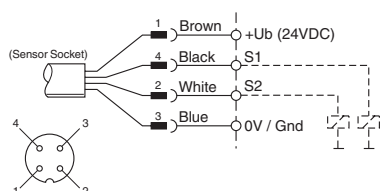
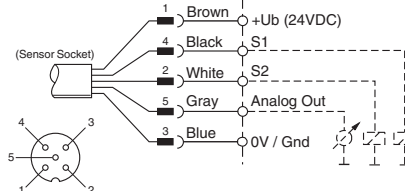
Pressure code	0250	016	1000	3000	5000	9000	250	600
Measure range PSI, (bar)	-14.7 to 250	(-1 to 16)	0 to 1000	0 to 3000	0 to 5000	0 to 9000	(0 to 250)	(0 to 600)
Overload pressure PSI, (bar)	725	(40)	2900	7250	11600	21750	(500)	(1200)
Burst pressure PSI, (bar)	725	(50)	11600	17400	24650	31900	(1200)	(2200)
Sensing element	Ceramic			Stainless Steel				
Parts in contact with media	Stainless steel 1.4404			Stainless steel 1.4404, 1.4542, NBR*				
	Ceramic AL203, NBR* *FPDM							
Units of measure	PSI, bar, MPA							
Switch cycles	>100 million							
Output response time	< 10ms							
Power supply	15 to 30VDC, Class 2 power supply							
Short circuit protection	Yes, 2.4 amp / open collector output							
Reverse polarity protection	Yes							
Overload protection	Yes							
Current consumption	< 100mA							
Output circuit	2 PNP (Sourcing) open collector transistor							
Analog output	0/4...20mA, Programmable, freely scaleable							
Output functions	Hysteresis, Window comparator							
Switching voltage	-1.5VDC							
Maximum current output	1A with 2 open collector outputs, .5A per output							
Accuracy	± 0.5% F.S. Typ., ± 1% Max.							
Repeatability	± 0.25% F.S.							
Display accuracy	± 0.5% F.S. Typ., ± 1 Digit							
Thermal error max.	±0.03% F.S. at -4 to 185°F (-20 to 85°C)							
Material	Pressure Die-cast zinc Z 410: Surface-finishing							
Display material	Polyester							
General protection	IP 67, EN60529, UL, CE Marked, EMC-EN50082-2 Class B, EN 50081-2							
Temperature range of media	-4 to 185°F (-20 to 85°C)							
Ambiant temperature range	-4 to 185°F (-20 to 85°C)							
Storage temperature	-40 to 212°F (-40 to 100°C)							
Display	4-Digit, 7-Segment LED, Red, 9mm height							
Tightening torque	35Nm							
Vibration resistance	20G, 10 to 500Hz, IEC60068-2-6							
Shock resistance	50 G, XYZ, 11ms, IEC60068-2-29							
Mass	10.6 oz. (300g)							

Internal circuit
M12, 4-Pin, (2) PNP Outputs

M12, 5-Pin, (2) PNP Outputs with 4 to 20mA Analog

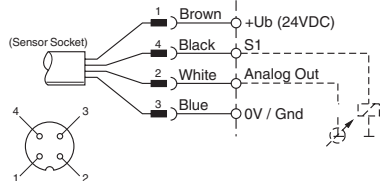
Note: M12, 5-Pin Female Cable Connector will fit on both M12, 4-Pin and 5-Pin Male Sensor Connector.

M12, 4-Pin, (1) PNP Output with 4 to 20mA Analog

Technical

MPS-37

MPS-34

SCP01

SCPSD

 Accessories,
Symbols,
Glossary

Dimensions

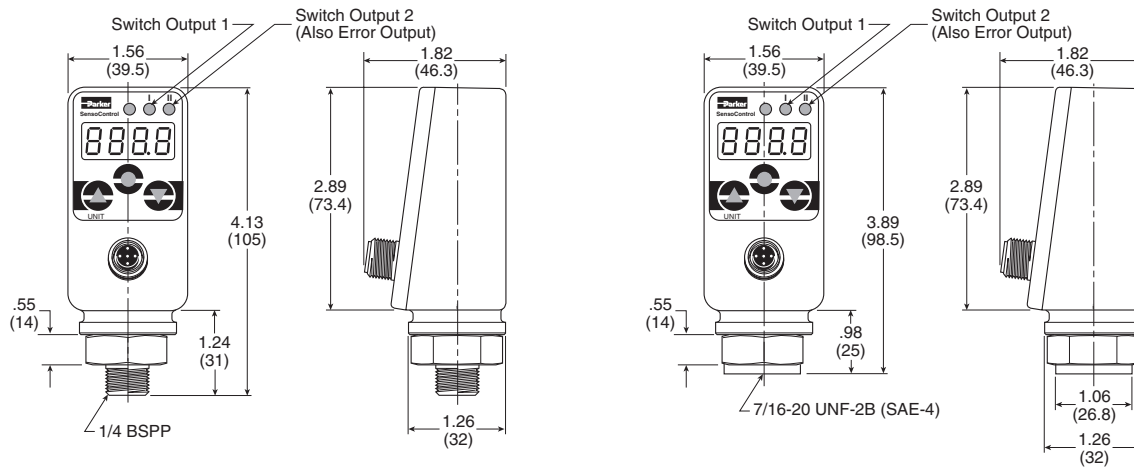

To program outputs and options of SCPSD, press and hold the **▲** (Up Arrow Icon) then press the **○** (Circle Icon) until Pro6 is displayed. Release all buttons and follow menu to program outputs and options.

To review programmed outputs and options of SCPSD, press and hold the **○** (Circle Icon) until Pro6 is displayed. Release the **○** (Circle Icon) and follow menu to program option and status.

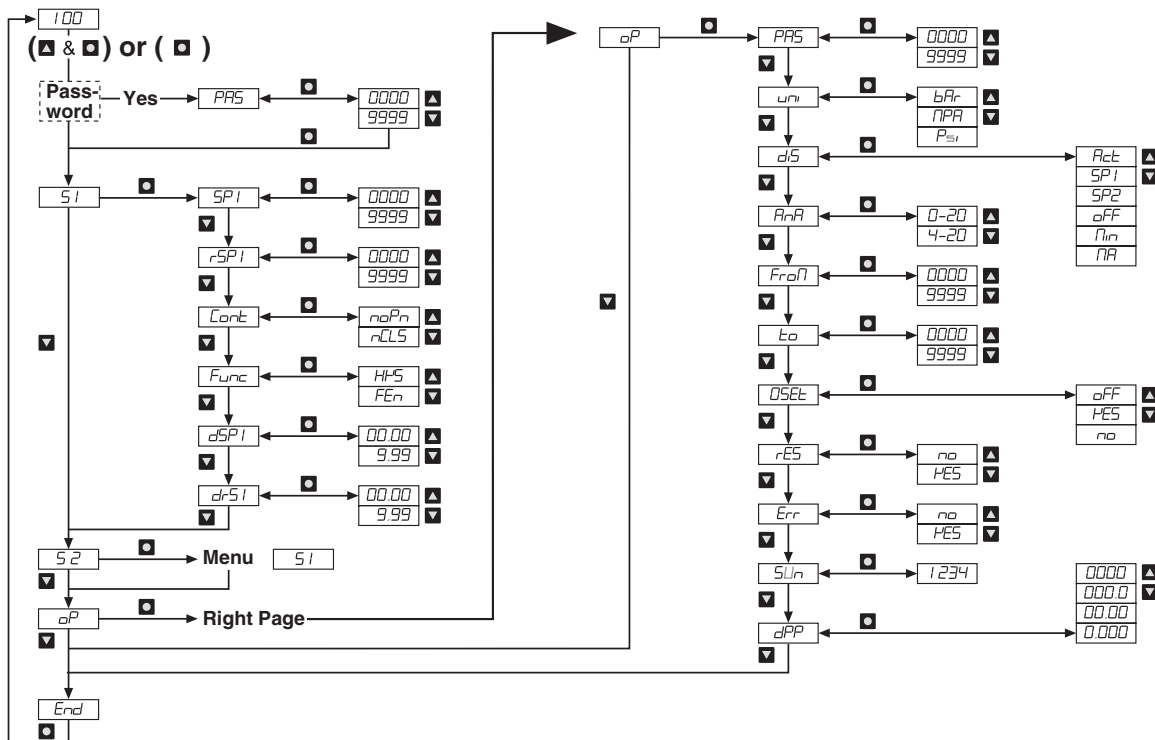

C

Technical

MPS-37

MPS-34

SCP01

SCPSD

Accessories, Symbols, Glossary



Programming Features

Parameters shown in digital display

To program switch outputs in menu S1 (S1 = output 1) or S2 (S2 = output 2), press **▲** and hold, then press **■**. Pro6 will be displayed for 2 seconds.

PRS	This is dedicated to a password. Entry into the programming mode can be secured only when the correct figures have been entered Menu for programming the switch outputs:
S1	S1 = Switch output 1
S2	S2 = Switch output 2 (Menu is not active if S2 is being used as an error output)
	Switching point (SP): upper limiting value / pressure, at which the switch output changes its status.
SP1	SP1 = Switch output 1; input as pressure value (e.g. 400 bar)
SP2	SP2 = Switch output 2; input as pressure value (e.g. 430 bar)
	Reverse switching point (rSP): lower limiting value/pressure at which switch output changes its status.
rSP1	rSP1 = Reverse switching point (rSP1) of switch output 1; input as pressure value (e.g. 390 bar)
rSP2	rSP2 = Reverse switching point (rSP2) of switch output 2; input as pressure value (e.g. 420 bar) The reverse switching point is always smaller than its respective switching point. If the reverse switching point is set higher than the switching point, the reverse switching point will be set automatically 0.5% of the instrument nominal pressure below the switching point. The warning sign Att (attention) will appear, which can be cleared with Enter. ■
cont	Switch output as noPn = closer nCLS = opener
Func	Selection of switching functions: HySt = Hysteresis function FEn = Window function
	Delay times; input from 0 to 9.99 s.
dSPI	dSPI = delay time switching point output 1
drSL	drSL = delay time reverse switching point output 1
dSP2	dSP2 = delay time switching point output 2
drS2	drS2 = delay time reverse switching point output 2



Pressure Sensors SCPSD High Pressure 316 Stainless Steel

Settings for options program

oP	Options program
PA5	Password input 0000 = no password Example password 1234 = 1234
uni	Setting of units: bAr = bar NPA = MPa PSi = PSI
diS	Display: Value which will be shown on the digital display in run mode. Act = Actual system pressure Nin = Minimum system pressure; (pressure troughs) NA = Maximum system pressure; (pressure peaks) SP1 = Switch point 1 SP2 = Switch point 2 OFF = off indication
AnA	Setting of analog output (see point 4) 0-20 = 0-20 mA 4-20 = 4-20 mA
FroN	Calibration of starting value (0 or 4 mA) for the analog output. Settable from 0 to nominal instrument pressure. Example for AnA = 4-20: 0000 = at 0 bar the analog output yields 4mA. ! The starting value is always smaller than the end value. If the starting value is set greater than the end value, then the starting value will be automatically set 5% of the nominal instrument pressure below that of the end value. The warning sign Att 1 will appear, which can be cleared with the Enter sign. ■
to	Calibration of end value (20mA) for the analog output. Settable from 0 up to nominal instrument pressure. 0010 = at 10 bar the analogue output yields 20 mA.
0Set	Zero adjustment: The actual pressure will be stored as a new zero point. For safety reasons this is limited to the range $\pm 5\%$ of the nominal instrument pressure. Application example: a system with a continuous residual pressure, but which should be displayed as 0 bar. OFF = factory calibration yES = undertake zeroing adjustment now no = go back to the menu and do not make any new zeroing adjustments. After a zeroing adjustment, a pressure of up to 20 bar can be displayed as 0 on a 400 bar SCPSD. Before working on a system, it must be ensured that there is no pressure in it.
!	!
rES	Clearing the minimum and maximum value memory yES = yes, clear memory now no = no, do not clear memory
Err	Programming switch output 2 as an error output yES = yes no = no Switch Output 2 can be used optionally as an error output to display pressure switch function errors. As an error output it is normally closed, and in case of errors (Err 1 , Err 2 , Err 3) it is open. At the same time LED II lights up. The display and the output remain active until the error is cleared.
SUn	Indication of Software Version
dPP	Setting of the decimal point. (The maximum number of decimal points depends on the nominal pressure of the SCPSD instrument) 0000 = no decimal point 000.0 = 1 decimal point 00.00 = 2 decimal points 0.000 = 3 decimal points
End	End of programming mode



Technical

MPS-37

MPS-34

SCP01

SCPSD

 Accessories,
Symbols,
Glossary

Installation

Mechanical:

⚠ CAUTION: Install and de-install the SCPSD only when there is no pressure present.

Attach the SCPSD to the appropriate process connection. Installation should be undertaken only with a 22mm, across flats spanner. Ensure that the digital display is placed in the best viewing position by using the rotational housing adjustment. Turn the SCPSD manually to the required position. Maximum 290°.

Excessive turning beyond the easily detectable end stop will lead to damage.

- The housing can be attached:
 - with self-tapping screws into two blind holes at the back of the housing
 - with the mounting plate provided
 - with cable ties

Electrical:

⚠ CAUTION: The SCPSD may be installed only by a qualified electrician in accordance with the respective national and international regulations.

Protect the SCPSD from electromagnetic influences and over-voltages.

Optional installation tips which are shown by experience to reduce the influence of interference:

- Use shorter cables
- Avoid short distances between connecting leads and power consuming devices and interference generating electrical and electronic equipment
- Use free running diodes

Avoid static and dynamic over-pressures which exceed the specified overload pressure. Even when the overload pressure is exceeded only for a short time the SCPSD may be damaged. Parker SensoControl diagnostic systems are recommended for measuring pressure peaks exactly.

If there is a danger of excessively high pressure peaks, it is recommended to:

- use an SCPSD with a higher nominal instrument pressure (analog output can then be correspondingly matched)
- install a standard throttling device upstream from the SCPSD

Error messages

Display	Description
<i>Att</i>	The set value is lower than the other respective parameters. When Enter is activated, the smaller value is matched up.
<i>Err1</i>	System Error (Internal)
<i>Err2</i>	Nominal instrument pressure range was exceeded by 10%. Please check system pressure.
<i>Err3</i>	Nominal instrument pressure range has been exceeded Error in analog electronics. Please check system pressure.

Electrical test unit (M12, 5-Pin)

SCSN-450-PSD



SCPSD programming kit

SCSD-PRG-KIT

Optical Interface Device that allows read / write and storing of SCPSD configuration data. Kit includes optical interface device, electrical test unit with PC cable (RS232 connector) and software.

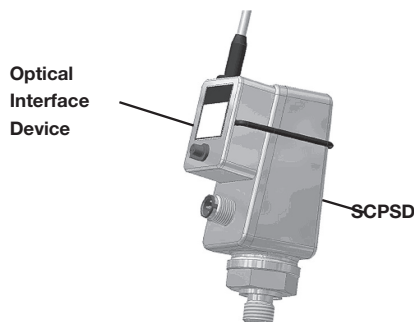

C
Technical
MPS-37
MPS-34
SCP01
SCPSD
Accessories, Symbols, Glossary

Features

- M8, M12 female connector
- Length: 2m or 5m
- Cover: PVC or PUR
- Connection type: Swivel straight or angled
- IP67 swivel connector

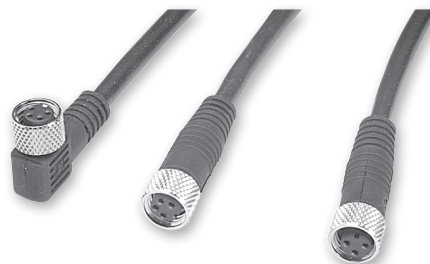

Common Part Numbers

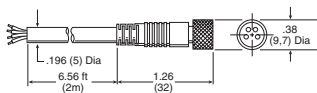
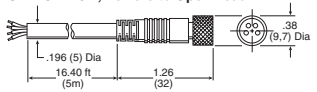
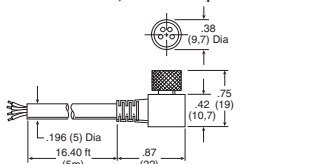
Connector	Contacts	Length	Cover	Part number
M8 female	4	2m	PUR	CB-M8-4P-2M
M8 female	4	5m	PUR	CB-M8-4P-5M
M8 angled female	4	5m	PUR	CB-M8-4P-5M-90
M12 female	4	2m	PVC	CB-M12-4P-2M
M12 female	5	2m	PVC	CB-M12-5P-2M

Dimensions
CB-M8-4P-2M, Female to Open Lead

CB-M8-4P-5M, Female to Open Lead

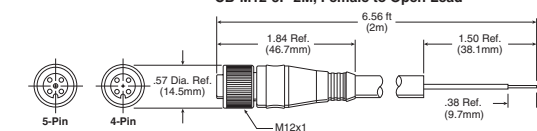
CB-M8-4P-5M-90, Female to Open Lead

Female Interface
4-Pin, M8

Cable Pin	Color
1	Brown
2	White
3	Blue
4	Black

Male Interface
4-Pin, M8

CB-M12-4P-2M, Female to Open Lead
CB-M12-5P-2M, Female to Open Lead

Female Interface
5-Pin, M12

Cable Pin	Color
1	Brown
2	White
3	Blue
4	Black
5	Gray

Female Interface
4-Pin, M12

Cable Pin	Color
1	Brown
2	White
3	Blue
4	Black

Most popular.



Glossary
A
Accuracy

The PERCENTAGE difference between the true value and that indicated by an instrument is the measure of the instrument's accuracy. It is expressed as a percentage of the full-scale value of the reading according to the type of instrument.

Analog output

An analog output provides an output voltage that is proportional and linear to the pressure measured by the sensor. This output signal provides continuous feedback to the analog card of the PLC.

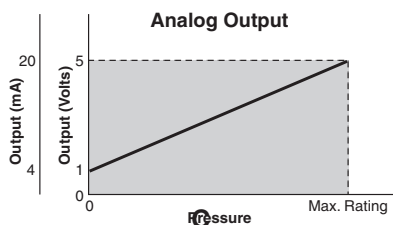
Cable connector type

4-Pin, M8 cable connector referred to as PICO or Micro connector. 4-Pin, 5-Pin, M12 cable connector referred to as Mini connector.

Class 2 power supply

Power source not exceeding 30VDC and 8 amps.

Connection port size

Pressure port connections on the back or bottom of the sensor.

Current consumption

Maximum current consumed during operation. Does not include the load current.

D
Display resolution

Resolution is 1/1024. The least possible measurable unit to display on the display. This will vary with the units of measure and is adjustable on some sensors.

Shown below are the different unit increments displayed for different pressures.

Compound	Low pressure	Vacuum	Pressure
bar: 0.01	bar: 0.001	bar: 0.001	bar: 0.01
kPa: 1	kPa: 0.1	kPa: 0.1	mPa: 0.001
kgf/cm ² : 0.01	kgf/cm ² : 0.001	mmHg: 1	kgf/cm ² : 0.01
PSI: 0.1	PSI: 0.1	inHg: 0.1	PSI: 1

Dielectric strength

Sensors ability to withstand excess voltages.

Digital display unit

Minimum unit displayed on the sensor.

E
Error message

Error message is displayed if the pressures, inputs, or outputs exceed the parameters of the sensor.

F
Full scale

Abbreviated as F.S. this is the operating pressure scale of the sensor.

G
Grommet type

Electrical lead from the sensor.

H
Hysteresis

The difference in pressure below the switch point pressure which controls the ON-OFF status of the output signal. (See Output modes)

I
Input impedance

The source of the electrical response of the sensing element expressed in ohms.

IP ratings

- IP40 - Protected against solid foreign objects of 0.04" (1mm) and greater.
Non-protected against the penetration of liquids.
- IP65 - Dust tight.
Protected against water jets.
- IP67 - Dust tight.
Protected against the effects of temporary immersion water.

Insulation resistance

Resistance between electrical circuit and the body, expressed in ohms at a voltage rating.

Internal voltage drop

Caused by the resistance of an electrical part in an electronic circuit. Example is a 2-wire pneumatic pressure switch.

L
LED

Electronic Display Technology

Load current

Amount of current flowing through the sensor once the output is activated.

Lock-out mode

Prevents accidental changes to the sensor settings.

M
Maximum operating pressure

Maximum operating pressure the sensor is rated for. Exceeding this pressure could damage the unit and will display FFF.

N
Noise resistance

Amount of electrical noise in the surrounding environment that could affect the sensor performance.

NPN pressure sensor output

NPN type open collector transistor outputs are solid state circuits that provide sinking output capabilities. When the transistor is on, the current for the load flows into the transistor. This output "sinks" toward 0VDC, 0mA.

C

Technical

MPS-37

MPS-34

SCP01

SCPSD

 Accessories,
Symbols,
Glossary

Glossary
O
ON / OFF output

The electrical state of the output signal.

Open collector transistor

Output circuit that sinks (NPN) or sources (PNP) at the pressure switch-point setting.

Operating humidity range

Humidity range for proper operation of equipment.

Operating indicator light

LED indicator is on when ON-OFF output is ON.

Operating pressure range

The pressure range the unit was designed to operate in.

Operating temperature range

Acceptable temperature range for the specifications listed in the catalog.

Operating voltage

Voltage range for normal operation.

Output modes
Switch point with hysteresis settings

This output mode provides one switch set point and a reversing point. The difference of these points is the hysteresis range (**h**). When the switch point pressure is achieved, the output (NPN / PNP) is activated if normally open or deactivated if normally closed. Typically, this mode is used for pressure confirmation. For positive pressure applications, this operating mode does not provide any output or alarms beyond the switch point in the case of excessive pressures.

In the Air Driven Cabinet Cooler application below, H=10 PSIG, h=2 PSIG. The unit will function properly above 10 PSIG and give some pressure variations, the sensor output will remain "on" until 8 PSIG. Below 8 PSIG the output will change to "off", which will be an indication that the cabinet is not being cooled efficiently or not at all.

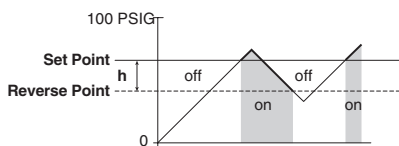
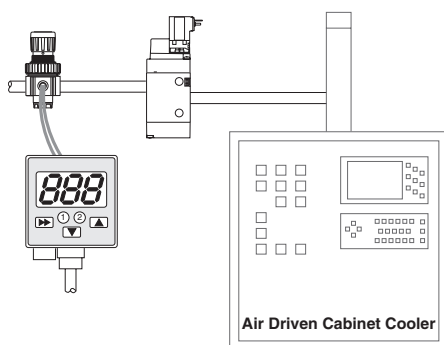
Window comparator setting

This output mode provides two switch points (A) and (b) that control the output signals (NPN / PNP) between the two pressures. This creates a "window" of operation and is sometimes referred to as "high / low" setting. The Window Comparator Mode provides an output or alarm when pressures exceed the upper or lower limit.

The sensor in the below application monitors the pressure to the valve controlling a pneumatic gripper. If the pressure is below (A), the gripper may not have enough holding capacity for the application and the part could drop. If the pressure is above b, the gripper may exert too much force on the part and damage the part. If the pressure is in the window of operation, in-between (A) and (b), the application is within design specification.

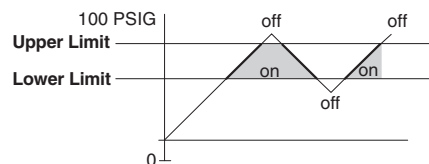
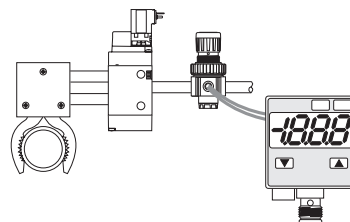
Output response time

Response time of the output signal after the pressure switch point is achieved. Measured in milliseconds.

P
Panel mounting brackets

Brackets used to panel mount the sensor.

PNP pressure sensor output

PNP type open collector transistor outputs are solid state circuits that provide sourcing output capabilities. When the transistor is on, the current for the load flows out of the transistor. This output "sources" toward 24VDC, 125mA.

R
Repeatability

The repeatability refers to the sensor's ability to provide the same output with consecutive applications of the same pressure input.

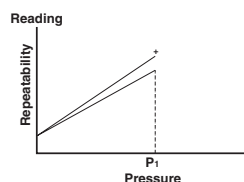

Repeatability is represented as a percentage of the full scale value of the sensor. All Parker sensors are rated $\pm 0.2\%$ F.S. P1 would be represented as $145 \text{ PSI} \times 0.002 = \pm 0.29 \text{ PSI}$.



Technical

MPS-37

MPS-34

SCP01

SCPSD

 Accessories,
Symbols,
Glossary

Glossary

Reverse voltage protection

Diode circuitry to prevent "cross-wire" damage during installation of the sensor.

S

Setpoints

The number of the ON-OFF output signals in one product. Product with 2 setting points means 2 output type.

Shock resistance

The amount of vibration the sensor can withstand without affecting performance.

Silicon diaphragm

This type of sensor is used for air and non-corrosive gas applications.

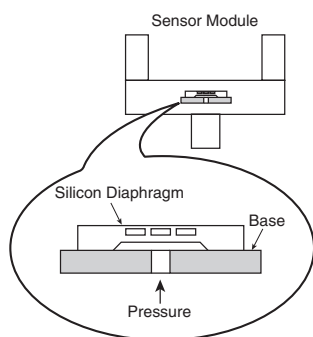

Stainless steel diaphragm

This type of sensor is used for liquids, non-corrosive to 316L or 630 stainless steel.

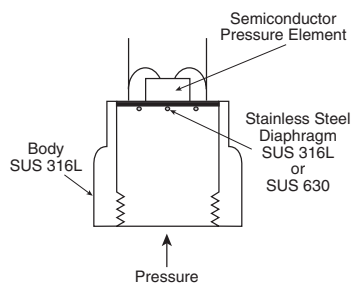

Switch output

This is a reference to a digital or NPN / PNP open collector transistor output from the sensor. The technology is binary logic.

T

Thermal error

Temperature characteristics vary with applications. The performance of the sensor can be affected by changes in ambient temperatures. The sensor rating is represented by a percentage of the F.S.

W

Wetted parts

Sensor body parts that are in contact with process-type fluids are referred to as wetted parts.

Z

Zero reset

The sensor technology is PSIA. Periodically, the sensor's atmospheric reference may need to be adjusted manually or automatically as a result of small changes in the atmospheric reference point.

C

Technical

MPS-37

MPS-34

SCP01

SCP5D

Accessories,
Symbols,
Glossary



Technical

MPS-37

MPS-34

SCP01

SCP5D

Accessories,
Symbols,
Glossary



Safety Guide For Selecting And Using Pneumatic Division Products And Related Accessories

⚠ **WARNING:**

FAILURE OR IMPROPER SELECTION OR IMPROPER USE OF PNEUMATIC DIVISION PRODUCTS, ASSEMBLIES OR RELATED ITEMS ("PRODUCTS") CAN CAUSE DEATH, PERSONAL INJURY, AND PROPERTY DAMAGE. POSSIBLE CONSEQUENCES OF FAILURE OR IMPROPER SELECTION OR IMPROPER USE OF THESE PRODUCTS INCLUDE BUT ARE NOT LIMITED TO:

- Unintended or mistimed cycling or motion of machine members or failure to cycle
- Work pieces or component parts being thrown off at high speeds.
- Failure of a device to function properly for example, failure to clamp or unclamp an associated item or device.
- Explosion
- Suddenly moving or falling objects.
- Release of toxic or otherwise injurious liquids or gasses.

Before selecting or using any of these Products, it is important that you read and follow the instructions below.

1. GENERAL INSTRUCTIONS

- 1.1. Scope:** This safety guide is designed to cover general guidelines on the installation, use, and maintenance of Pneumatic Division Valves, FRLs (Filters, Pressure Regulators, and Lubricators), Vacuum products and related accessory components.
- 1.2. Fail-Safe:** Valves, FRLs, Vacuum products and their related components can and do fail without warning for many reasons. Design all systems and equipment in a fail-safe mode, so that failure of associated valves, FRLs or Vacuum products will not endanger persons or property.
- 1.3. Relevant International Standards:** For a good guide to the application of a broad spectrum of pneumatic fluid power devices see: ISO 4414:1998, Pneumatic Fluid Power – General Rules Relating to Systems. See www.iso.org for ordering information.
- 1.4. Distribution:** Provide a copy of this safety guide to each person that is responsible for selection, installation, or use of Valves, FRLs or Vacuum products. Do not select, or use Parker valves, FRLs or vacuum products without thoroughly reading and understanding this safety guide as well as the specific Parker publications for the products considered or selected.
- 1.5. User Responsibility:** Due to the wide variety of operating conditions and applications for valves, FRLs, and vacuum products Parker and its distributors do not represent or warrant that any particular valve, FRL or vacuum product is suitable for any specific end use system. This safety guide does not analyze all technical parameters that must be considered in selecting a product. The user, through its own analysis and testing, is solely responsible for:
 - Making the final selection of the appropriate valve, FRL, Vacuum component, or accessory.
 - Assuring that all user's performance, endurance, maintenance, safety, and warning requirements are met and that the application presents no health or safety hazards.
 - Complying with all existing warning labels and / or providing all appropriate health and safety warnings on the equipment on which the valves, FRLs or Vacuum products are used; and,
 - Assuring compliance with all applicable government and industry standards.
- 1.6. Safety Devices:** Safety devices should not be removed, or defeated.
- 1.7. Warning Labels:** Warning labels should not be removed, painted over or otherwise obscured.
- 1.8. Additional Questions:** Call the appropriate Parker technical service department if you have any questions or require any additional information. See the Parker publication for the product being considered or used, or call 1-800-CPARKER, or go to www.parker.com, for telephone numbers of the appropriate technical service department.

2. PRODUCT SELECTION INSTRUCTIONS

- 2.1. Flow Rate:** The flow rate requirements of a system are frequently the primary consideration when designing any pneumatic system. System components need to be able to provide adequate flow and pressure for the desired application.
- 2.2. Pressure Rating:** Never exceed the rated pressure of a product. Consult product labeling, Pneumatic Division catalogs or the instruction sheets supplied for maximum pressure ratings.
- 2.3. Temperature Rating:** Never exceed the temperature rating of a product. Excessive heat can shorten the life expectancy of a product and result in complete product failure.
- 2.4. Environment:** Many environmental conditions can affect the integrity and suitability of a product for a given application. Pneumatic Division products are designed for use in general purpose industrial applications. If these products are to be used in unusual circumstances such as direct sunlight and/or corrosive or caustic environments, such use can shorten the useful life and lead to premature failure of a product.
- 2.5. Lubrication and Compressor Carryover:** Some modern synthetic oils can and will attack nitrile seals. If there is any possibility of synthetic oils or greases migrating into the pneumatic components check for compatibility with the seal materials used. Consult the factory or product literature for materials of construction.
- 2.6. Polycarbonate Bowls and Sight Glasses:** To avoid potential polycarbonate bowl failures:
 - Do not locate polycarbonate bowls or sight glasses in areas where they could be subject to direct sunlight, impact blow, or temperatures outside of the rated range.
 - Do not expose or clean polycarbonate bowls with detergents, chlorinated hydro-carbons, ketones, esters or certain alcohols.
 - Do not use polycarbonate bowls or sight glasses in air systems where compressors are lubricated with fire resistant fluids such as phosphate ester and di-ester lubricants.

D

Safety Guide,
Offer of Sale



D1

Parker Hannifin Corporation
 Pneumatic Division
 Richland, Michigan
www.parker.com/pneumatics

- 2.7. Chemical Compatibility:** For more information on plastic component chemical compatibility see Pneumatic Division technical bulletins Tec-3, Tec-4, and Tec-5
- 2.8. Product Rupture:** Product rupture can cause death, serious personal injury, and property damage.
- Do not connect pressure regulators or other Pneumatic Division products to bottled gas cylinders.
 - Do not exceed the maximum primary pressure rating of any pressure regulator or any system component.
 - Consult product labeling or product literature for pressure rating limitations.

3. PRODUCT ASSEMBLY AND INSTALLATION INSTRUCTIONS

- 3.1. Component Inspection:** Prior to assembly or installation a careful examination of the valves, FRLs or vacuum products must be performed. All components must be checked for correct style, size, and catalog number. DO NOT use any component that displays any signs of nonconformance.
- 3.2. Installation Instructions:** Parker published Installation Instructions must be followed for installation of Parker valves, FRLs and vacuum components. These instructions are provided with every Parker valve or FRL sold, or by calling 1-800-CPARKER, or at www.parker.com.
- 3.3. Air Supply:** The air supply or control medium supplied to Valves, FRLs and Vacuum components must be moisture-free if ambient temperature can drop below freezing

4. VALVE AND FRL MAINTENANCE AND REPLACEMENT INSTRUCTIONS

- 4.1. Maintenance:** Even with proper selection and installation, valve, FRL and vacuum products service life may be significantly reduced without a continuing maintenance program. The severity of the application, risk potential from a component failure, and experience with any known failures in the application or in similar applications should determine the frequency of inspections and the servicing or replacement of Pneumatic Division products so that products are replaced before any failure occurs. A maintenance program must be established and followed by the user and, at minimum, must include instructions 4.2 through 4.10.
- 4.2. Installation and Service Instructions:** Before attempting to service or replace any worn or damaged parts consult the appropriate Service Bulletin for the valve or FRL in question for the appropriate practices to service the unit in question. These Service and Installation Instructions are provided with every Parker valve and FRL sold, or are available by calling 1-800-CPARKER, or by accessing the Parker web site at www.parker.com.
- 4.3. Lockout / Tagout Procedures:** Be sure to follow all required lockout and tagout procedures when servicing equipment. For more information see: OSHA Standard – 29 CFR, Part 1910.147, Appendix A, The Control of Hazardous Energy – (Lockout / Tagout)
- 4.4. Visual Inspection:** Any of the following conditions requires immediate system shut down and replacement of worn or damaged components:
- Air leakage: Look and listen to see if there are any signs of visual damage to any of the components in the system. Leakage is an indication of worn or damaged components.
 - Damaged or degraded components: Look to see if there are any visible signs of wear or component degradation.
 - Kinked, crushed, or damaged hoses. Kinked hoses can result in restricted air flow and lead to unpredictable system behavior.
 - Any observed improper system or component function: Immediately shut down the system and correct malfunction.
 - Excessive dirt build-up: Dirt and clutter can mask potentially hazardous situations.

Caution: Leak detection solutions should be rinsed off after use.

- 4.5. Routine Maintenance Issues:**
- Remove excessive dirt, grime and clutter from work areas.
 - Make sure all required guards and shields are in place.
- 4.6. Functional Test:** Before initiating automatic operation, operate the system manually to make sure all required functions operate properly and safely.
- 4.7. Service or Replacement Intervals:** It is the user's responsibility to establish appropriate service intervals. Valves, FRLs and vacuum products contain components that age, harden, wear, and otherwise deteriorate over time. Environmental conditions can significantly accelerate this process. Valves, FRLs and vacuum components need to be serviced or replaced on routine intervals. Service intervals need to be established based on:
- Previous performance experiences.
 - Government and / or industrial standards.
 - When failures could result in unacceptable down time, equipment damage or personal injury risk.
- 4.8. Servicing or Replacing of any Worn or Damaged Parts:** To avoid unpredictable system behavior that can cause death, personal injury and property damage:
- Follow all government, state and local safety and servicing practices prior to service including but not limited to all OSHA Lockout Tagout procedures (OSHA Standard – 29 CFR, Part 1910.147, Appendix A, The Control of Hazardous Energy – Lockout / Tagout).
 - Disconnect electrical supply (when necessary) before installation, servicing, or conversion.
 - Disconnect air supply and depressurize all air lines connected to system and Pneumatic Division products before installation, service, or conversion.
 - Installation, servicing, and / or conversion of these products must be performed by knowledgeable personnel who understand how pneumatic products are to be applied.
 - After installation, servicing, or conversions air and electrical supplies (when necessary) should be connected and the product tested for proper function and leakage. If audible leakage is present, or if the product does not operate properly, do not put product or system into use.
 - Warnings and specifications on the product should not be covered or painted over. If masking is not possible, contact your local representative for replacement labels.
- 4.9. Putting Serviced System Back into Operation:** Follow the guidelines above and all relevant Installation and Maintenance Instructions supplied with the valve FRL or vacuum component to insure proper function of the system.

D

Safety Guide,
Offer of Sale



PARKER-HANNIFIN CORPORATION
OFFER OF SALE

1. **Definitions.** As used herein, the following terms have the meanings indicated.

Buyer:	means any customer receiving a Quote for Products from Seller.
Goods:	means any tangible part, system or component to be supplied by the Seller.
Products:	means the Goods, Services and/or Software as described in a Quote provided by the Seller.
Quote:	means the offer or proposal made by Seller to Buyer for the supply of Products.
Seller:	means Parker-Hannifin Corporation, including all divisions and businesses thereof.
Services:	means any services to be supplied by the Seller.
Software:	means any software related to the Products, whether embedded or separately downloaded.
Terms:	means the terms and conditions of this Offer of Sale or any newer version of the same as published by Seller electronically at www.parker.com/saleterms .

2. **Terms.** All sales of Products by Seller are contingent upon, and will be governed by, these Terms and, these Terms are incorporated into any Quote provided by Seller to any Buyer. Buyer's order for any Products whether communicated to Seller verbally, in writing, by electronic data interface or other electronic commerce, shall constitute acceptance of these Terms. Seller objects to any contrary or additional terms or conditions of Buyer. Reference in Seller's order acknowledgement to Buyer's purchase order or purchase order number shall in no way constitute an acceptance of any of Buyer's terms of purchase. No modification to these Terms will be binding on Seller unless agreed to in writing and signed by an authorized representative of Seller.

3. **Price; Payment.** The Products set forth in Seller's Quote are offered for sale at the prices indicated in Seller's Quote. Unless otherwise specifically stated in Seller's Quote, prices are valid for thirty (30) days and do not include any sales, use, or other taxes or duties. Seller reserves the right to modify prices at any time to adjust for any raw material price fluctuations. Unless otherwise specified by Seller, all prices are F.C.A. Seller's facility (INCOTERMS 2010). All sales are contingent upon credit approval and payment for all purchases is due thirty (30) days from the date of invoice (or such date as may be specified in the Quote). Unpaid invoices beyond the specified payment date incur interest at the rate of 1.5% per month or the maximum allowable rate under applicable law.

4. **Shipment; Delivery; Title and Risk of Loss.** All delivery dates are approximate. Seller is not responsible for damages resulting from any delay. Regardless of the manner of shipment, delivery occurs and title and risk of loss or damage pass to Buyer, upon placement of the Products with the shipment carrier at Seller's facility. Unless otherwise agreed, Seller may exercise its judgment in choosing the carrier and means of delivery. No deferral of shipment at Buyer's request beyond the respective indicated shipping date will be made except on terms that will indemnify, defend and hold Seller harmless against all loss and additional expense. Buyer shall be responsible for any additional shipping charges incurred by Seller due to Buyer's acts or omissions.

5. **Warranty.** The warranty related to the Products is as follows: (i) Goods are warranted against defects in material or workmanship for a period of twelve (12) months from the date of delivery or 2,000 hours of use, whichever occurs first; (ii) Services shall be performed in accordance with generally accepted practices and using the degree of care and skill that is ordinarily exercised and customary in the field to which the Services pertain and are warranted for a period of six (6) months from the completion of the Services by Seller; and (iii) Software is only warranted to perform in accordance with applicable specifications provided by Seller to Buyer for ninety (90) days from the date of delivery or, when downloaded by a Buyer or end-user, from the date of the initial download. All prices are based upon the exclusive limited warranty stated above, and upon the following disclaimer:

DISCLAIMER OF WARRANTY: THIS WARRANTY IS THE SOLE AND ENTIRE WARRANTY PERTAINING TO PRODUCTS. SELLER DISCLAIMS ALL OTHER WARRANTIES, EXPRESS AND IMPLIED, INCLUDING DESIGN, NONINFRINGEMENT, MERCHANTABILITY, AND FITNESS FOR A PARTICULAR PURPOSE. SELLER DOES NOT WARRANT THAT THE SOFTWARE IS ERROR-FREE OR FAULT-TOLERANT, OR THAT BUYER'S USE THEREOF WILL BE SECURE OR UNINTERRUPTED. BUYER AGREES AND ACKNOWLEDGES THAT UNLESS OTHERWISE AUTHORIZED IN WRITING BY SELLER THE SOFTWARE SHALL NOT BE USED IN CONNECTION WITH HAZARDOUS OR HIGH RISK ACTIVITIES OR ENVIRONMENTS. EXCEPT AS EXPRESSLY STATED HEREIN, ALL PRODUCTS ARE PROVIDED "AS IS".

6. **Claims; Commencement of Actions.** Buyer shall promptly inspect all Products upon receipt. No claims for shortages will be allowed unless reported to the Seller within ten (10) days of delivery. Buyer shall notify Seller of any alleged breach of warranty within thirty (30) days after the date the non-conformance is or should have been discovered by Buyer. Any claim or action against Seller based upon breach of contract or any other theory, including tort, negligence, or otherwise must be commenced within twelve (12) months from the date of the alleged breach or other alleged event, without regard to the date of discovery.

7. **LIMITATION OF LIABILITY.** IN THE EVENT OF A BREACH OF WARRANTY, SELLER WILL, AT ITS OPTION, REPAIR OR REPLACE THE NON-CONFORMING PRODUCT, RE-PERFORM THE SERVICES, OR REFUND THE PURCHASE PRICE PAID WITHIN A REASONABLE PERIOD OF TIME. IN NO EVENT IS SELLER LIABLE FOR ANY SPECIAL, INDIRECT, INCIDENTAL OR CONSEQUENTIAL DAMAGES ARISING OUT OF, OR AS THE RESULT OF, THE SALE, DELIVERY, NON-DELIVERY, SERVICING, NON-COMPLETION OF SERVICES, USE, LOSS OF USE OF, OR INABILITY TO USE THE PRODUCTS OR ANY PART THEREOF, LOSS OF DATA, IDENTITY, PRIVACY, OR CONFIDENTIALITY, OR FOR ANY CHARGES OR EXPENSES OF ANY NATURE INCURRED WITHOUT SELLER'S WRITTEN CONSENT, WHETHER BASED IN CONTRACT, TORT OR OTHER LEGAL THEORY. IN NO EVENT SHALL SELLER'S LIABILITY UNDER ANY CLAIM MADE BY BUYER EXCEED THE PURCHASE PRICE PAID FOR THE PRODUCTS.

8. **Loss to Buyer's Property.** Any designs, tools, patterns, materials, drawings, confidential information or equipment furnished by Buyer or any other items which are or become Buyer's property, will be considered obsolete and may be destroyed by Seller after two (2) consecutive years have elapsed without Buyer ordering the Products manufactured using such property. Seller shall not be responsible for any loss or damage to such property while it is in Seller's possession or control.

9. **Special Tooling.** Special Tooling includes but is not limited to tooling, jigs, fixtures and associated manufacturing equipment acquired or necessary to manufacture Products. A tooling charge may be imposed for any Special Tooling. Such Special Tooling shall be and remain Seller's property notwithstanding payment of any charges by Buyer. In no event will Buyer acquire any interest in Special Tooling belonging to Seller that is utilized in the manufacture of the Products, even if such Special Tooling has been specially converted or adapted for such manufacture and notwithstanding any charges paid by Buyer. Unless otherwise agreed, Seller has the right to alter, discard or otherwise dispose of any Special Tooling or other property in its sole discretion at any time.

10. **Security Interest.** To secure payment of all sums due, Seller retains a security interest in all Products delivered to Buyer and, Buyer's acceptance of these Terms is deemed to be a Security Agreement under the Uniform Commercial Code. Buyer authorizes Seller as its attorney to execute and file on Buyer's behalf all documents Seller deems necessary to perfect its security interest.

11. **User Responsibility.** The Buyer through its own analysis and testing, is solely responsible for making the final selection of the Products and assuring that all performance, endurance, maintenance, safety and warning requirements of the application of the Products are met. The Buyer must analyze all aspects of the application and follow applicable industry standards, specifications, and other technical information provided with the Product. If Seller provides Product options based upon data or specifications provided by the Buyer, the Buyer is responsible for determining that such data and specifications are suitable and sufficient for all applications and reasonably foreseeable uses of the Products. In the event the Buyer is not the end-user, Buyer will ensure such end-user complies with this paragraph.

12. **Use of Products; Indemnity by Buyer.** Buyer shall comply with all instructions, guides and specifications provided by Seller with the Products. **Unauthorized Uses.** If Buyer uses or resells the Products for any uses prohibited in Seller's instructions, guides or specifications, or Buyer otherwise fails to comply with Seller's instructions, guides and specifications, Buyer acknowledges that any such use, resale, or non-compliance is at Buyer's sole risk. Buyer shall indemnify, defend, and hold Seller harmless from any losses, claims, liabilities, damages, lawsuits, judgments and costs (including attorney fees and defense costs), whether for personal injury, property damage, intellectual property infringement or any other claim, brought by or incurred by Buyer, Buyer's employees, or any other person, arising out of: (a) improper selection, application, design, specification or other misuse of Products provided by Seller; (b) any act or omission, negligent or otherwise, of Buyer; (c) Seller's use of patterns, tooling, equipment, plans, drawings, designs or specifications or other information or things furnished by Buyer; (d) damage to the Products from an external cause, repair or attempted repair by anyone other than Seller, failure to follow instructions, guides and specifications provided by Seller, use with goods not provided by Seller, or opening, modifying, deconstructing or tampering with the Products for any reason; or (e) Buyer's failure to comply with these Terms. Seller shall not indemnify Buyer under any circumstance except as otherwise provided in these Terms.

13. **Cancellations and Changes.** Buyer may not cancel or modify any order for any reason, except with Seller's written consent and upon terms that will indemnify, defend and hold Seller harmless against all direct, incidental and consequential loss or damage. Seller, at any time, may change Product features, specifications, designs and availability.

14. **Limitation on Assignment.** Buyer may not assign its rights or obligations without the prior written consent of Seller.

15. **Force Majeure.** Seller does not assume the risk and is not liable for delay or failure to perform any of Seller's obligations by reason of events or circumstances beyond its reasonable control ("Events of Force Majeure"). Events of Force Majeure shall include without limitation: accidents, strikes or labor disputes, acts of any government or government agency, acts of nature, delays or failures in delivery from carriers or suppliers, shortages of materials, or any other cause beyond Seller's reasonable control.

16. **Waiver and Severability.** Failure to enforce any provision of these Terms will not invalidate that provision; nor will any such failure prejudice Seller's right to enforce that provision in the future. Invalidation of any provision of these Terms by legislation or other rule of law shall not invalidate any other provision herein and, the remaining provisions will remain in full force and effect.

17. **Termination.** Seller may terminate any agreement governed by or arising from these Terms for any reason and at any time by giving Buyer thirty (30) days prior written notice. Seller may immediately terminate, in writing, if Buyer: (a) breaches any provision of these Terms (b) appoints a trustee, receiver or custodian for all or any part of Buyer's property (c) files a petition for relief in bankruptcy on its own behalf, or one if filed by a third party (d) makes an assignment for the benefit of creditors; or (e) dissolves its business or liquidates all or a majority of its assets.

18. **Ownership of Software.** Seller retains ownership of all Software supplied to Buyer hereunder. In no event shall Buyer obtain any greater right in and to the Software than a right in the nature of a license limited to the use thereof and subject to compliance with any other terms provided with the Software.

19. **Indemnity for Infringement of Intellectual Property Rights.** Seller is not liable for infringement of any patents, trademarks, copyrights, trade dress, trade secrets or similar rights ("Intellectual Property Rights") except as provided in this Section. Seller will defend at its expense and will pay the cost of any settlement or damages awarded in an action brought against Buyer based on a third party claim that one or more of the Products sold hereunder infringes the Intellectual Property Rights of a third party in the country of delivery of the Products by the Seller to the Buyer. Seller's obligation to defend and indemnify Buyer is contingent on Buyer notifying Seller within ten (10) days after Buyer becomes aware of any such claim, and Seller having sole control over the defense of the claim including all negotiations for settlement or compromise. If one or more Products sold hereunder is subject to such a claim, Seller may, at its sole expense and option, procure for Buyer the right to continue using the Products, replace or modify the Products so as to render them non-infringing, or offer to accept return of the Products and refund the purchase price less a reasonable allowance for depreciation. Seller has no obligation or liability for any claim of infringement: (i) arising from information provided by Buyer; or (ii) directed to any Products provided hereunder for which the designs are specified in whole or part by Buyer; or (iii) resulting from the modification, combination or use in a system of any Products provided hereunder. The foregoing provisions of this Section constitute Seller's sole and exclusive liability and Buyer's sole and exclusive remedy for such claims of infringement of Intellectual Property Rights.

20. **Governing Law.** These Terms and the sale and delivery of all Products are deemed to have taken place in, and shall be governed and construed in accordance with, the laws of the State of Ohio, as applicable to contracts executed and wholly performed therein and without regard to conflicts of laws principles. Buyer irrevocably agrees and consents to the exclusive jurisdiction and venue of the courts of Cuyahoga County, Ohio with respect to any dispute, controversy or claim arising out of or relating to the sale and delivery of the Products.

21. **Entire Agreement.** These Terms, along with the terms set forth in the main body of any Quote, forms the entire agreement between the Buyer and Seller and constitutes the final, complete and exclusive expression of the terms of sale. In the event of a conflict between any term set forth in the main body of a Quote and these Terms, the terms set forth in the main body of the Quote shall prevail. All prior or contemporaneous written or oral agreements or negotiations with respect to the subject matter shall have no effect. These Terms may not be modified unless in writing and signed by an authorized representative of Seller.

22. **Compliance with Laws.** Buyer agrees to comply with all applicable laws, regulations, and industry and professional standards, including those of the United States of America, and the country or countries in which Buyer may operate, including without limitation the U.S. Foreign Corrupt Practices Act ("FCPA"), the U.S. Anti-Kickback Act ("Anti-Kickback Act"), U.S. and E.U. export control and sanctions laws ("Export Laws"), the U.S. Food Drug and Cosmetic Act ("FDCA"), and the rules and regulations promulgated by the U.S. Food and Drug Administration ("FDA"), each as currently amended. Buyer agrees to indemnify, defend, and hold harmless Seller from the consequences of any violation of such laws, regulations and standards by Buyer, its employees or agents. Buyer acknowledges that it is familiar with all applicable provisions of the FCPA, the Anti-Kickback Act, Export Laws, the FDCA and the FDA and certifies that Buyer will adhere to the requirements thereof and not take any action that would make Seller violate such requirements. Buyer represents and agrees that Buyer will not make any payment or give anything of value, directly or indirectly, to any governmental official, foreign political party or official thereof, candidate for foreign political office, or commercial entity or person, for any improper purpose, including the purpose of influencing such person to purchase Products or otherwise benefit the business of Seller. Buyer further represents and agrees that it will not receive, use, service, transfer or ship any Product from Seller in a manner or for a purpose that violates Export Laws or would cause Seller to be in violation of Export Laws.



Parker Hannifin Corporation

Pneumatic Division

8676 E. M89

Richland, MI 49083 USA

Tel: 269 629 5000

Applications Engineering: pdnapps@parker.com

Customer Support: pdncustsvc@parker.com

Web site: www.parker.com/pneumatics