



Hydraulic Saw Motor

Series F11/F12
Fixed Displacement



parker.com/pmde



ENGINEERING YOUR SUCCESS.

Basic formulas for hydraulic motors

Flow (q)

$$q = \frac{D \times n}{1000 \times \eta_v} \text{ [l/min]}$$

D - displacement [cm³/rev]

n - shaft speed [rpm]

η_v - volumetric efficiency

Δp - differential pressure [bar]

(between inlet and outlet)

η_{hm} - mechanical efficiency

η_t - overall efficiency

($\eta_t = \eta_v \times \eta_{hm}$)

Torque (M)

$$M = \frac{D \times \Delta p \times \eta_{hm}}{63} \text{ [Nm]}$$

Power (P)

$$P = \frac{q \times \Delta p \times \eta_t}{600} \text{ [kW]}$$

Basic formulas for hydraulic pumps

Flow (q)

$$q = \frac{D \times n \times \eta_v}{1000} \text{ [l/min]}$$

D - displacement [cm³/rev]

n - shaft speed [rpm]

η_v - volumetric efficiency

Δp - differential pressure [bar]

(between inlet and outlet)

η_{hm} - mechanical efficiency

η_t - overall efficiency

($\eta_t = \eta_v \times \eta_{hm}$)

Torque (M)

$$M = \frac{D \times \Delta p}{63 \times \eta_{hm}} \text{ [Nm]}$$

Power (P)

$$P = \frac{q \times \Delta p}{600 \times \eta_t} \text{ [kW]}$$

Conversion factors

1 kg.....	2.20 lb
1 N.....	0.225 lbf
1 Nm.....	0.738 lbf ft
1 bar.....	14.5 psi
1 l.....	0.264 US gallon
1 cm ³	0.061 cu in
1 mm.....	0.039 in
1 °C.....	⁵ / ₉ (°F-32)
1 kW.....	1.34 hp

Conversion factors

1 lb.....	0.454 kg
1 lbf.....	4.448 N
1 lbf ft.....	1.356 Nm
1 psi.....	0.068948 bar
1 US gallon.....	3.785 l
1 cu in.....	16.387 cm ³
1 in.....	25.4 mm
1 °F.....	⁹ / ₅ °C + 32
1 hp.....	0.7457 kW



Content	Page
General Information.....	4
Introduction.....	4
The optimal saw motor	4
Benefits.....	4
Technical information.....	5
Saw motor versions	5
Parker Power Boost.....	5
Specifications	6
Ordering codes.....	7
Installation dimensions	
F11-6 and -10 saw motor version without make up valve.....	8
F11-6 and -10 saw motor version with make up valve.....	9
F11-12 and -14 saw motor version with make up valve.....	10
F11-19 saw motor version with make up valve.....	11
F12-30 saw motor version with make up valve.....	12
F12-40 saw motor version without make up valve.....	13
F12-60 motor versions.....	13
Installation information.....	14
Case drain connections.....	14

Introduction

Parker Hannifin offers an extensive range of components suitable for forestry machines and can assist with an optimal technical solution to obtain the most cost-efficient system.

Based on many years of experience from forestry applications, product development has been focused on helping manufacturers obtain the best possible performance from their machines. Many of our products have, therefore, been developed in direct and close cooperation with customers.

Parker Hannifin holds a leading position when it comes to product and application knowledge, dedicated to serve the forestry machine market.

We have components such as pumps, cylinders, motors, directional control valves, remote controls and electronic equipment for most of the hydraulic functions on any forestry machine.



The optimal saw motor

Series F11/F12 motors have proven extremely reliable in demanding applications such as bar (chain) saw drives. Primarily due to the 40 degree bent-axis design, spherical, light weight pistons (with laminated piston rings) and timing gear, extremely high speeds can be allowed, and the reliability is not affected even by low-temperature start-ups.

To further enhance the saw function and, at the same time, reduce weight, cost and installation dimensions, Parker has developed a motor which is specifically dedicated to bar saws. Based on the well proven F11/F12 design, the saw motor permits saw bar bearings to be mounted directly on the motor housing, and the chain spur gear installs on the motor shaft without the need for additional bearings.

The saw flange has integrated ports for auxiliary functions.

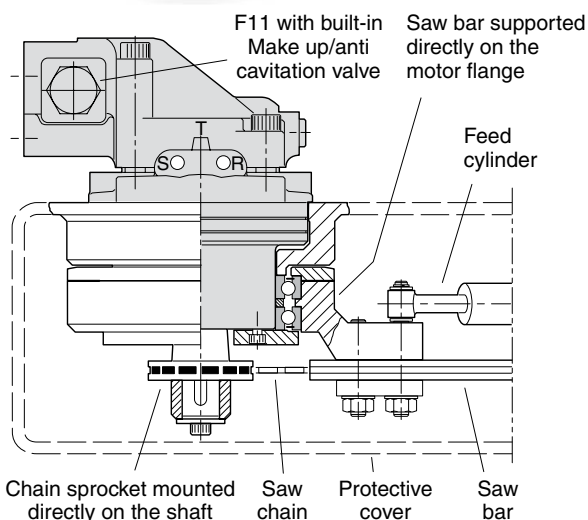

Chain saw installation (example; F11-10 shown)

Benefits

- Simple installation - lower cost
- Sturdier saw bar support
- Lower overall weight
- Much more compact installation
- Same mounting flange installation dimensions for all sizes



Saw motor versions

The saw motor is available in eight sizes, 6, 10, 12, 14, 19, 30, 40 and 60 cm³/rev. Motors between 6 to 30 cm³/rev are equipped with an integrated, large capacity make-up (anti-cavitation) valve. The valve reduces the risk of cavitation when the pump supply is suddenly shut off while the motor is still running at high speed. A counter-pressure of around 10 bar (measured in port B in the exemplified schematic below) is recommended.

The make-up valve makes the motor directional; when ordering, either R (right hand/clockwise) or L (left hand/counter clockwise) rotation must be specified.

When ordering a motor with make up valve, it is to be specified in product code. Ex below.

F12-030-SF-WS-X-284-MUVL-B0

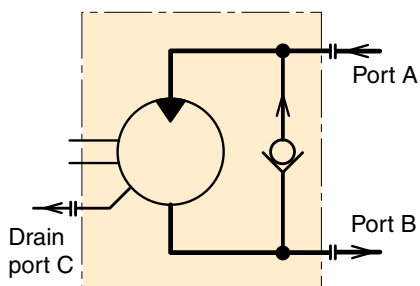

Hydraulic schematic, the motor is shown with make-up valve; shaft rotation 'L' (MUVL)

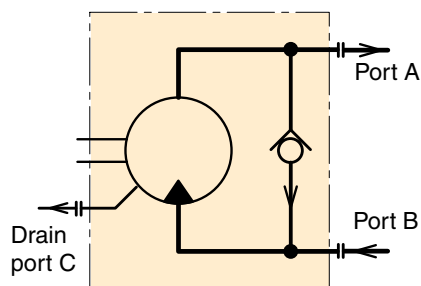

Hydraulic schematic, the motor is shown with make-up valve; shaft rotation 'R' (MUVR)

Parker Power Boost

A high speed F11 or F12 motor could be optimized with a Power Boost™, which means less fluid friction and oil compression. This can reduce power losses by up to 5 kW. The improved efficiency generates less heat, reducing the need for cooling and consequently improves fuel consumption.

Parker Power Boost is available for size F11-006, -010, -012, -014, -019 and F12-030.

When to order a motor with Power Boost it is to be specified in product code. Ex below.

F12-030-SF-WS-X-284-MUVL-B0



Specifications

Frame size F11/F12	-006	-010	-012	-014	-019	-030	-040	-060
Displacement [cm ³ /rev]	6.0	9.8	12.5	14.3	19.0	30.0	40.0	59.8
Max Operating pressure [bar]	420	420	420	420	420	420	480	480
Max Motor operating speed [rpm]	11 200	11 200	10 300	9 900	8 900	8600	6700	5800
Drain temperature³⁾, max [°C]	115	115	115	115	115	115	115	115
min [°C]	-40	-40	-40	-40	-40	-40	-40	-40
Theoretical torque at 100 bar [Nm]	9.5	15.6	19.8	22.7	30.2	47.6	63.5	94.9
Mass moment of inertia								
(x10 ⁻³) [kg m ²]	0.39	0.39	0.40	0.42	1.1	1.7	2.9	5.0
Weight [kg]	7.5	7.5	8.2	8.3	11	12	16.5	21

3) See also installation information. Page 14

Chain		0.404"	Chain speed 40 m/s								
Sprocket	No of teeth	11	12	13	14	15	16	17	18	19	20
Motor speed	rpm	10700	9800	9000	8400	7850	7350	6900	6550	5900	5350
F11-006	l/min	66	60	55	51	–	–	–	–	–	–
F11-010	l/min	107	98	90	84	–	–	–	–	–	–
F11-012	l/min	–	125	115	107	100	–	–	–	–	–
F11-014	l/min	–	143	131	123	115	–	–	–	–	–
F11-019	l/min	–	–	174	163	152	143	134	–	–	–
F12-030	l/min	–	–	–	–	240	225	211	201	181	164
F12-040	l/min	–	–	–	–	–	–	–	267	241	218
F12-060	l/min	–	–	–	–	–	–	–	–	360	326

Chain		3/4"	Chain speed 30 m/s				
Sprocket	No of teeth	7	8	9	10	11	12
Motor speed	rpm	6500	5700	5050	4550	4150	3800
F12-030	l/min	199	174	155	139	127	116
F12-040	l/min	265	233	206	186	169	155
F12-060	l/min	–	348	308	278	253	232

	-		-			-			-			-			-		
Serie		Frame size		Function		Main ports		Mounting flange		Shaft seal		Shaft		Version number		Option page 5	Option page 5
F11 F12														Version number (assigned for special versions)			

Frame size		Code	Displacem. (cm ³ /rev)
006*	6.0		
010*	9.8		
012*	12.5		
014*	14.3		
019*	19.0		
030**	30.0		
040**	40.0		
060**	59.8		

* F11
** F12

Frame size	6	10	12	14	19	30	40	60
Code	Function							
M	Motor							
S	Motor, high speed							

Frame size	6	10	12	14	19	30	40	60
Code	Main ports							
B	BSP threads							
F	Metric SAE 6000 psi flange							

Frame size	6	10	12	14	19	30	40	60
Code	Mounting flange							
W	Saw motor flange							
C	CETOP / Cartridge							

Frame size	6	10	12	14	19	30	40	60
Code	Shaft seal							
S	PTFE, high speed							

Frame size	6	10	12	14	19	30	40	60
Code	Shaft							
K	Metric key, (Std)							
P	Metric key (25 mm)							
X	Metric key, (Saw motor flange)							

Frame size	6	10	12	14	19	30	40	60
Code	Option							
0000	Standard							
MUVR	Make up/Anti cavitation valve clockwise rotation							
MUVL	Make up/Anti cavitation valve counter clockwise rotation							

Frame size	6	10	12	14	19	30	40	60
Code	Option							
00	Standard							
B_	Power Boost							
_T	Painted Black							

x: Available (x): Optional -: Not available

F11-6 and -10 saw motor version without make up valve

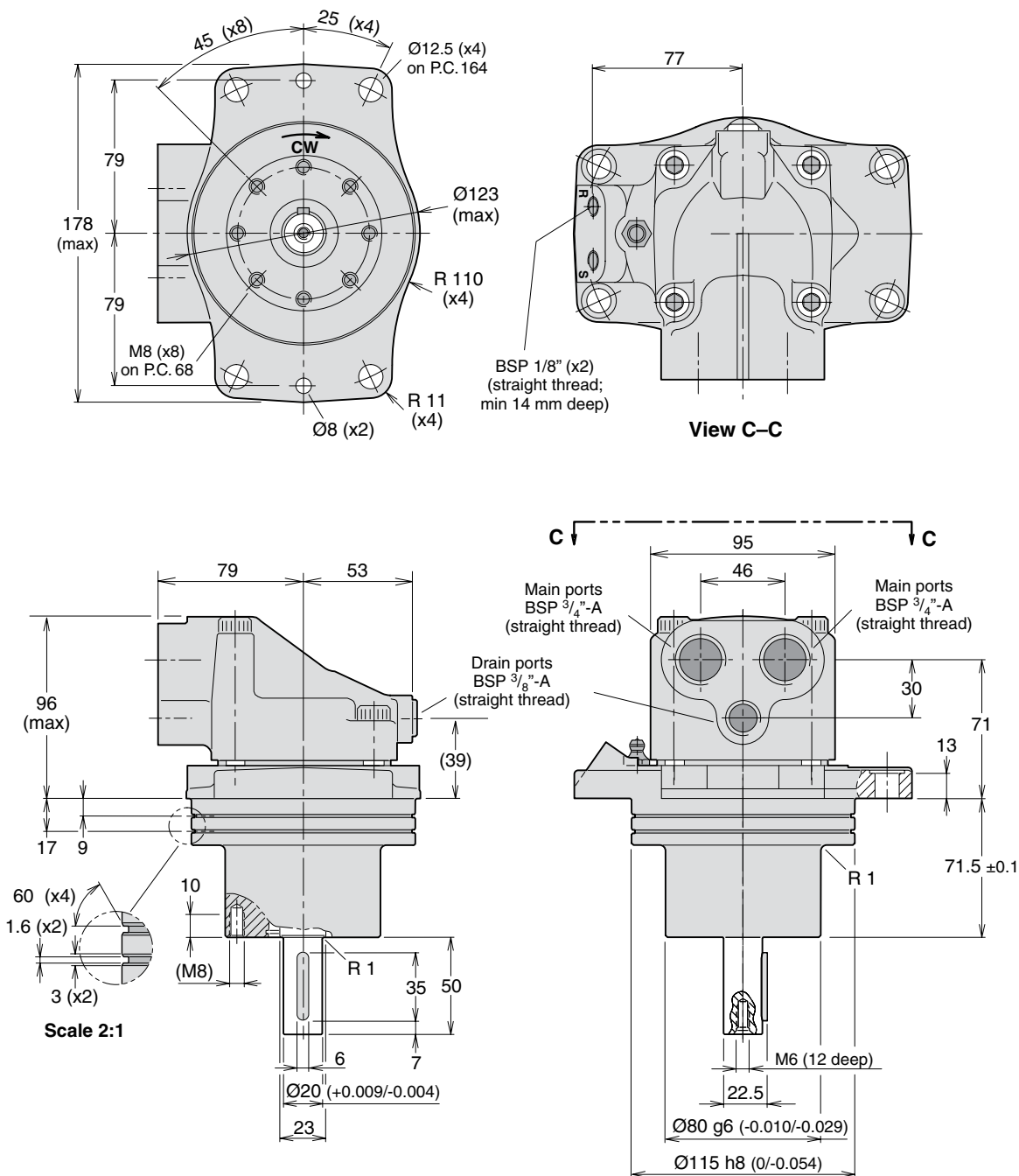

F11-6 and -10 saw motor version with make up valve

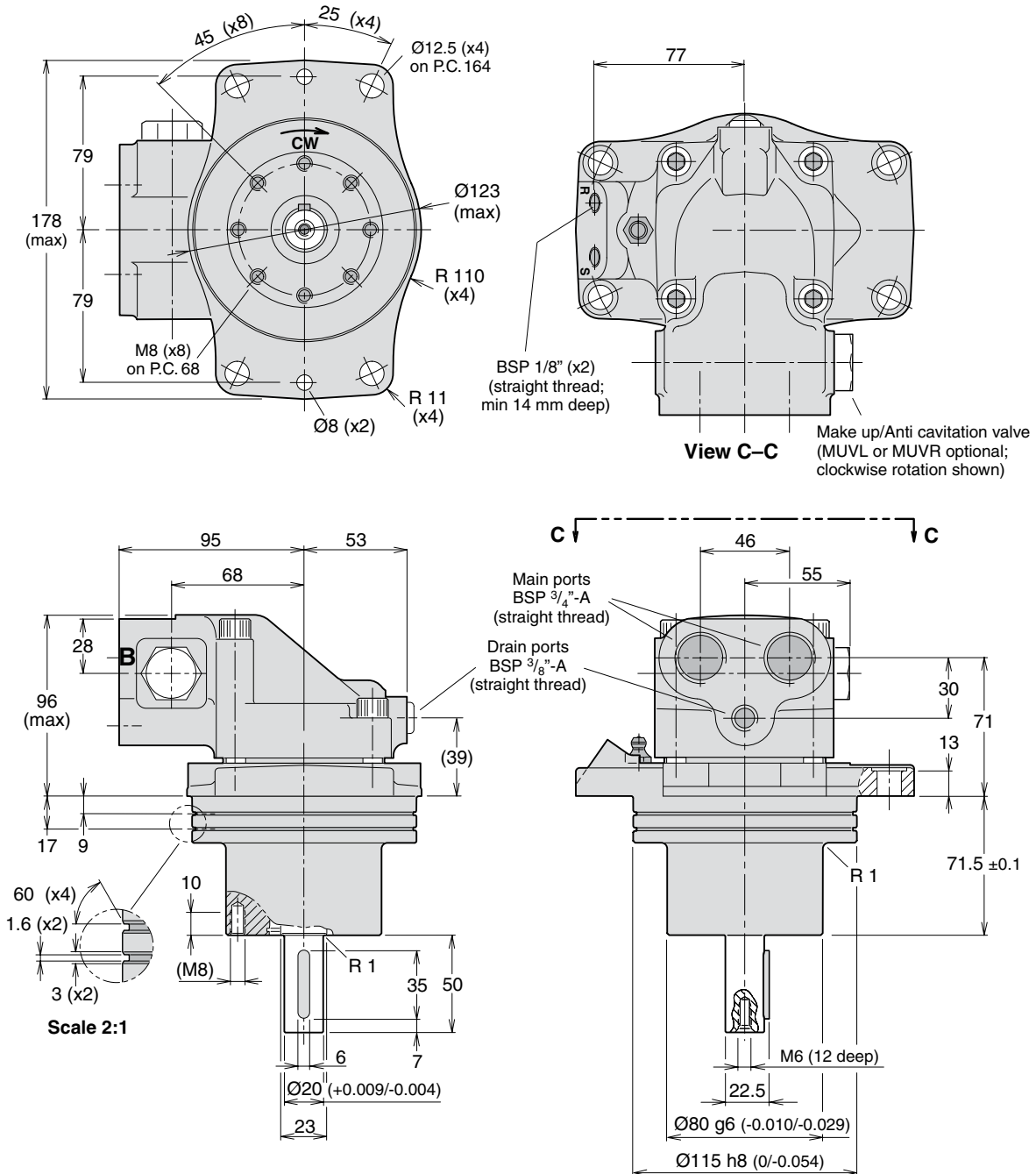

F11-12 and -14 saw motor version with make up valve

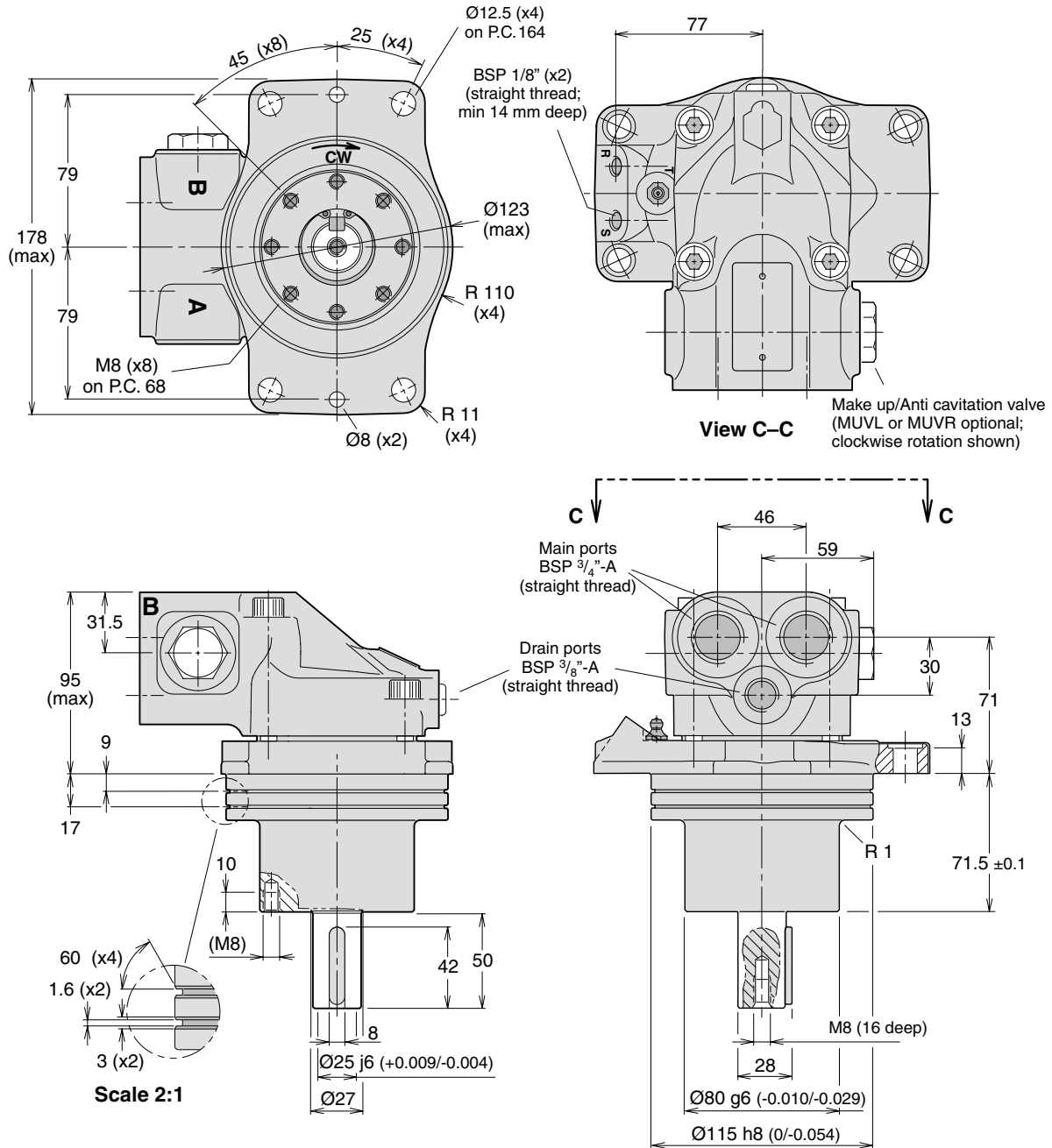

F11-19 saw motor version with make up valve

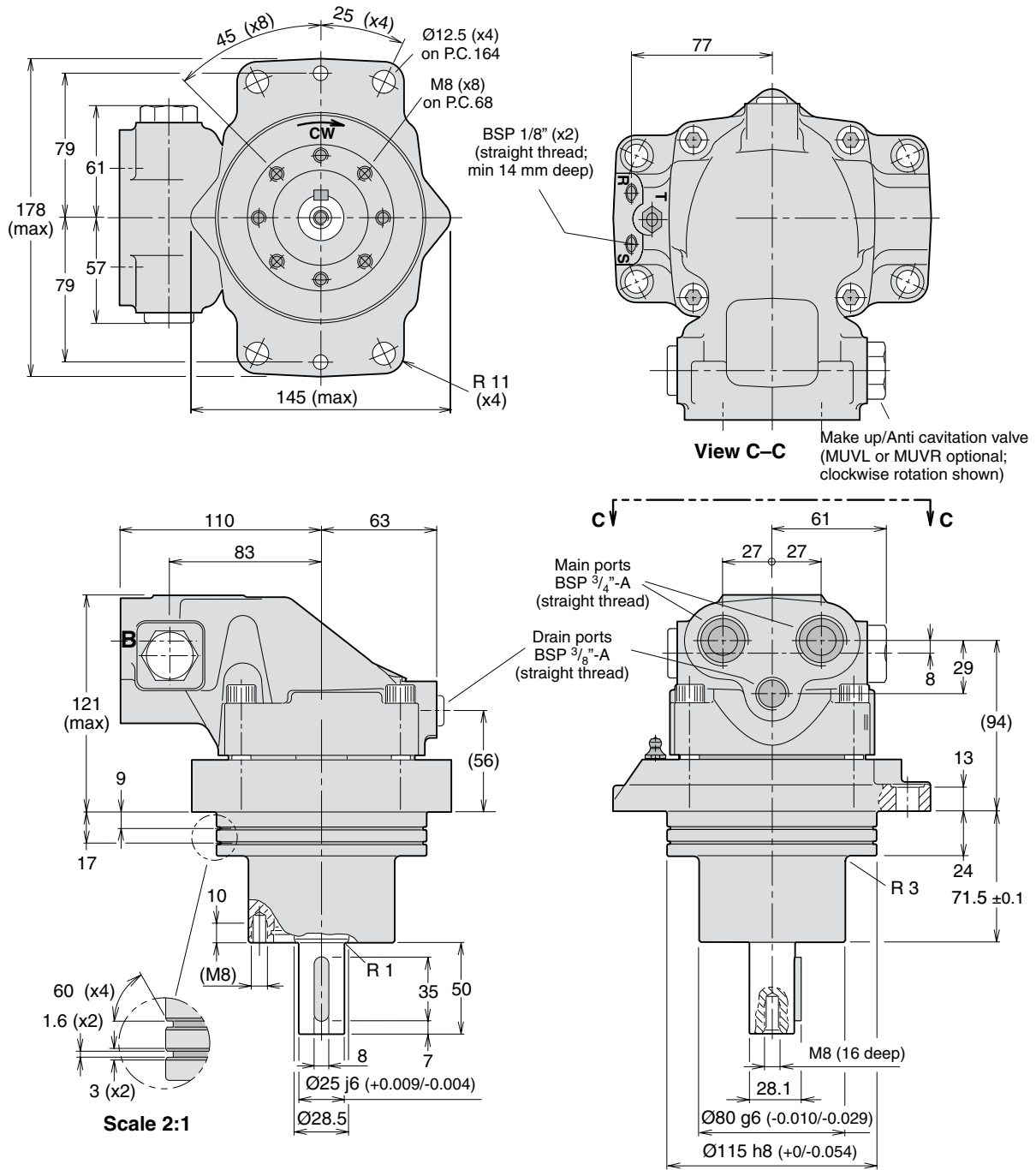

F12-30 saw motor version with make up valve

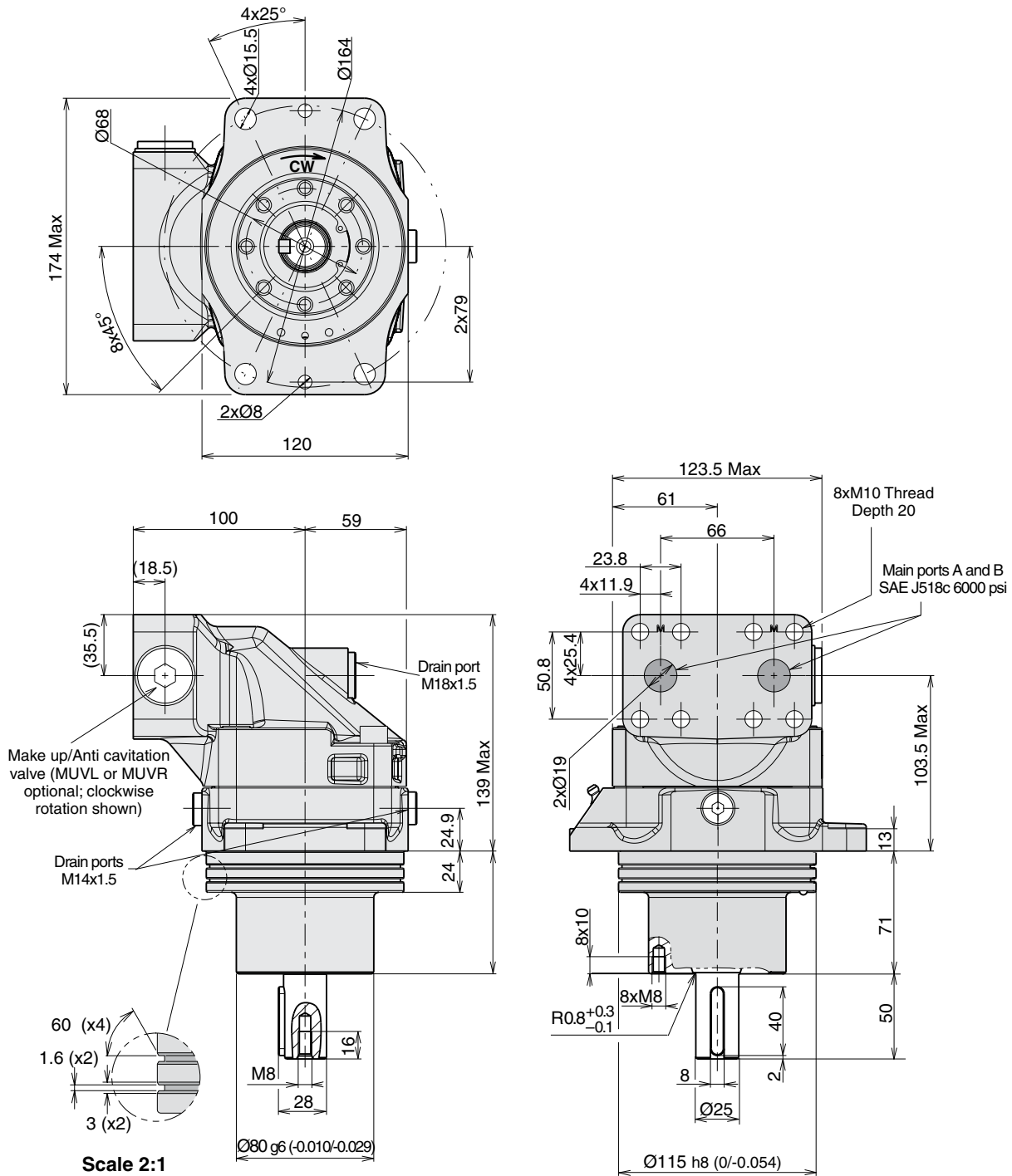

Hydraulic fluids

The saw motor data shown in the specification are valid when operating on a high quality, mineral based fluid with a minimum of contamination.

Hydraulic fluids type HLP (DIN 51524), ATF (automatic transmission fluid), and API type CD engine oils are suitable.

Operating temperature

The fluid temperature in the main hydraulic system must not exceed 70 °C; the drain fluid must not exceed 115 °C. **NOTE:** Fluid temperature should be measured at the utilized motor drain port.

Case pressure

The service life of the shaft seal ring is affected by the speed of the motor and the case drain pressure and it can decrease with an increase in the frequency of pressure peaks.

Note, seal life can be shorter at unfavourable operating conditions (cavitation, over speed, high temperature, low oil viscosity, contaminated oil).

The case pressure must be equal to or greater than the external pressure on the shaft seal ring.

Viscosity

The ideal viscosity for the saw motor is 15–30 mm²/s (cSt). When the hydraulic system has reached full operating temperature, the drain fluid viscosity must not be lower than 8 mm²/s.

(measured at the utilized motor drain port).

Max start-up viscosity: 1 000 mm²/s..

Filtration

Long saw motor life can be expected if fluid cleanliness meets or exceeds 'ISO code 20/18/13' (according to ISO 4406).

Under normal operating conditions a filtration level of 10 µm (absolute) is recommended.

Case drain connections

Series F11/F12 has two drain ports, C and D.

To secure correct case pressure and lubrication a spring loaded check valve in the drain line is recommended.

F12

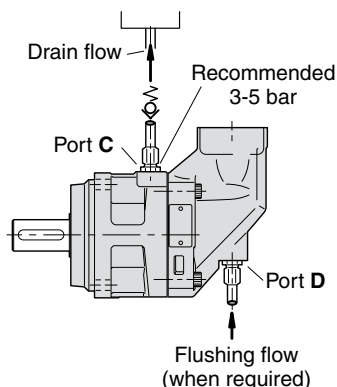

F11

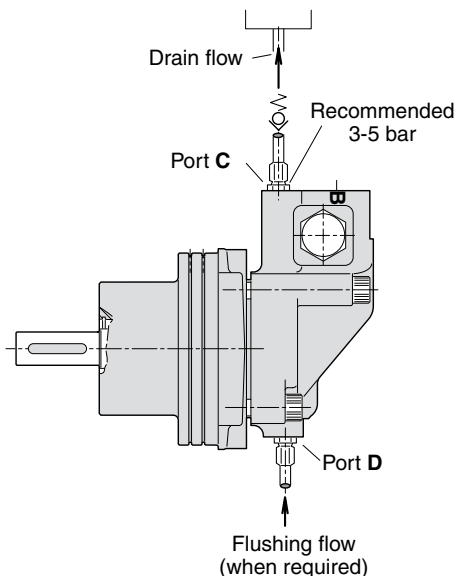



WARNING – USER RESPONSIBILITY

FAILURE OR IMPROPER SELECTION OR IMPROPER USE OF THE PRODUCTS DESCRIBED HEREIN OR RELATED ITEMS CAN CAUSE DEATH, PERSONAL INJURY AND PROPERTY DAMAGE.

This document and other information from Parker-Hannifin Corporation, its subsidiaries and authorized distributors provide product or system options for further investigation by users having technical expertise.

The user, through its own analysis and testing, is solely responsible for making the final selection of the system and components and assuring that all performance, endurance, maintenance, safety and warning requirements of the application are met. The user must analyze all aspects of the application, follow applicable industry standards, and follow the information concerning the product in the current product catalog and in any other materials provided from Parker or its subsidiaries or authorized distributors.

To the extent that Parker or its subsidiaries or authorized distributors provide component or system options based upon data or specifications provided by the user, the user is responsible for determining that such data and specifications are suitable and sufficient for all applications and reasonably foreseeable uses of the components or systems.

Offer of Sale

Please contact your Parker representation for a detailed "Offer of Sale".



Parker Worldwide

Europe, Middle East, Africa

AE – United Arab Emirates, Dubai
Tel: +971 4 8127100
parker.me@parker.com

AT – Austria, Wiener Neustadt
Tel: +43 (0)2622 23501-0
parker.austria@parker.com

AT – Eastern Europe, Wiener Neustadt
Tel: +43 (0)2622 23501 900
parker.easteurope@parker.com

AZ – Azerbaijan, Baku
Tel: +994 50 22 33 458
parker.azerbaijan@parker.com

BE/LU – Belgium, Nivelles
Tel: +32 (0)67 280 900
parker.belgium@parker.com

BG – Bulgaria, Sofia
Tel: +359 2 980 1344
parker.bulgaria@parker.com

BY – Belarus, Minsk
Tel: +48 (0)22 573 24 00
parker.poland@parker.com

CH – Switzerland, Etoy
Tel: +41 (0)21 821 87 00
parker.switzerland@parker.com

CZ – Czech Republic, Klecany
Tel: +420 284 083 111
parker.czechrepublic@parker.com

DE – Germany, Kaarst
Tel: +49 (0)2131 4016 0
parker.germany@parker.com

DK – Denmark, Ballerup
Tel: +45 43 56 04 00
parker.denmark@parker.com

ES – Spain, Madrid
Tel: +34 902 330 001
parker.spain@parker.com

FI – Finland, Vantaa
Tel: +358 (0)20 753 2500
parker.finland@parker.com

FR – France, Contamine s/Arve
Tel: +33 (0)4 50 25 80 25
parker.france@parker.com

GR – Greece, Athens
Tel: +30 210 933 6450
parker.greece@parker.com

HU – Hungary, Budaoers
Tel: +36 23 885 470
parker.hungary@parker.com

IE – Ireland, Dublin
Tel: +353 (0)1 466 6370
parker.ireland@parker.com

IT – Italy, Corsico (MI)
Tel: +39 02 45 19 21
parker.italy@parker.com

KZ – Kazakhstan, Almaty
Tel: +7 7273 561 000
parker.easteurope@parker.com

NL – The Netherlands, Oldenzaal
Tel: +31 (0)541 585 000
parker.nl@parker.com

NO – Norway, Asker
Tel: +47 66 75 34 00
parker.norway@parker.com

PL – Poland, Warsaw
Tel: +48 (0)22 573 24 00
parker.poland@parker.com

PT – Portugal
Tel: +351 22 999 7360
parker.portugal@parker.com

RO – Romania, Bucharest
Tel: +40 21 252 1382
parker.romania@parker.com

RU – Russia, Moscow
Tel: +7 495 645-2156
parker.russia@parker.com

SE – Sweden, Spånga
Tel: +46 (0)8 59 79 50 00
parker.sweden@parker.com

SK – Slovakia, Banská Bystrica
Tel: +421 484 162 252
parker.slovakia@parker.com

SL – Slovenia, Novo Mesto
Tel: +386 7 337 6650
parker.slovenia@parker.com

TR – Turkey, Istanbul
Tel: +90 216 4997081
parker.turkey@parker.com

UA – Ukraine, Kiev
Tel: +48 (0)22 573 24 00
parker.poland@parker.com

UK – United Kingdom, Warwick
Tel: +44 (0)1926 317 878
parker.uk@parker.com

ZA – South Africa, Kempton Park
Tel: +27 (0)11 961 0700
parker.southafrica@parker.com

North America

CA – Canada, Milton, Ontario
Tel: +1 905 693 3000

US – USA, Cleveland (industrial)
Tel: +1 216 896 3000

US – USA, Elk Grove Village (mobile)
Tel: +1 847 258 6200

Asia Pacific

AU – Australia, Castle Hill
Tel: +61 (0)2-9634 7777

CN – China, Shanghai
Tel: +86 21 2899 5000

HK – Hong Kong
Tel: +852 2428 8008

ID – Indonesia, Tangerang
Tel: +62 21 7588 1906

IN – India, Mumbai
Tel: +91 22 6513 7081-85

JP – Japan, Fujisawa
Tel: +81 (0)4 6635 3050

KR – South Korea, Seoul
Tel: +82 2 559 0400

MY – Malaysia, Shah Alam
Tel: +60 3 7849 0800

NZ – New Zealand, Mt Wellington
Tel: +64 9 574 1744

SG – Singapore
Tel: +65 6887 6300

TH – Thailand, Bangkok
Tel: +662 186 7000

TW – Taiwan, New Taipei City
Tel: +886 2 2298 8987

VN – Vietnam, Ho Chi Minh City
Tel: +84 8 3999 1600

South America

AR – Argentina, Buenos Aires
Tel: +54 3327 44 4129

BR – Brazil, Cachoeirinha RS
Tel: +55 51 3470 9144

CL – Chile, Santiago
Tel: +56 2 623 1216

MX – Mexico, Toluca
Tel: +52 72 2275 4200

Ed. 2016-04-04

EMEA Product Information Centre

Free phone: 00 800 27 27 5374

(from AT, BE, CH, CZ, DE, DK, EE, ES, FI, FR, IE, IL, IS, IT, LU, MT, NL, NO, PL, PT, RU, SE, SK, UK, ZA)

US Product Information Centre

Toll-free number: 1-800-27 27 537

www.parker.com/pmde

Your local authorized Parker distributor

