



aerospace
climate control
electromechanical
filtration
fluid & gas handling
hydraulics
pneumatics
process control
sealing & shielding



M402LS

Mobile Directional Control Valve

Proportional, Load Sensing



ENGINEERING YOUR SUCCESS.

Catalogue layout

In addition to general information and basic technical data, this catalogue contains descriptions of the many optional functions you can specify for the M402LS, so that we may customize it to control your machine optimally.

Each function area of the valve is given as a subheading, followed by a brief description. When different options are available for a function area, the subheading is followed by an item number in square brackets, e.g. **Prioritizing function [P16]**. This is followed by a series of coded options, e.g. **PR1** together with a brief description of what each code represents.

Alternatively, one or more pressure, flow or voltage options are given.

On page 8-9 is a general circuit diagram, which shows the basic function areas of the M402LS, as well as the item numbers that represent them. The same item numbers are of course used in all sub-circuit diagrams elsewhere in the catalogue. Please note that, unless stated otherwise, all sections and views of the valves have been drawn as seen from the inlet section.

Computer-aided valve specification

We have developed a computer program to specify the M402LS on the basis of the criteria for each individual machine function. The program facilitates optimal configuration of the valve for maximum performance in different applications. It also generates documentation in the form of a detailed specification and hydraulic circuit diagram for your valve, as well as a unique ID number that is stamped into the valve data plate. Your valve specifications are then stored on our database to facilitate rapid identification in the event of service enquiries or re-ordering.

Early consultation with Parker saves time and money

Our experienced engineers have in-depth knowledge of different types of hydraulic system and the ways in which they work. They are at your disposal to offer expert advice on the best system for the desired combination of machine functions, control characteristics and economic criteria. By consulting Parker early in the project planning stage, you are assured of a comprehensive hydraulic system that gives your machine the best possible operating and control characteristics.

Conversion factors

1 kg	= 2.2046 lb
1 N	= 0.22481 lbf
1 bar	= 14.504 psi
1 l	= 0.21997 UK gallon
1 l	= 0.26417 US gallon
1 cm ³	= 0.061024 in ³
1 m	= 3.2808 feet
1 mm	= 0.03937 in
9/5 °C + 32	= °F

Parker reserves the right to modify products without prior notice. Typical curves and diagrams are used in this catalogue. Even though the catalogue is revised and updated continuously, there is always the possibility of errors. For more detailed information about the products, please contact Parker Hannifin.



WARNING – USER RESPONSIBILITY

FAILURE OR IMPROPER SELECTION OR IMPROPER USE OF THE PRODUCTS DESCRIBED HEREIN OR RELATED ITEMS CAN CAUSE DEATH, PERSONAL INJURY AND PROPERTY DAMAGE.

This document and other information from Parker-Hannifin Corporation, its subsidiaries and authorized distributors provide product or system options for further investigation by users having technical expertise.

The user, through its own analysis and testing, is solely responsible for making the final selection of the system and components and assuring that all performance, endurance, maintenance, safety and warning requirements of the application are met. The user must analyze all aspects of the application, follow applicable industry standards, and follow the information concerning the product in the current product catalog and in any other materials provided from Parker or its subsidiaries or authorized distributors.

To the extent that Parker or its subsidiaries or authorized distributors provide component or system options based upon data or specifications provided by the user, the user is responsible for determining that such data and specifications are suitable and sufficient for all applications and reasonably foreseeable uses of the components or systems.

Offer of Sale

Please contact your Parker representation for a detailed "Offer of Sale".



Contents	Page
Catalogue Information	4
General Information.....	5
Essential characteristics	5
Technical Data	6
Pressure	6
Flow rate (recommended)	6
Leakage from service port to tank.....	6
Environmental characteristics.....	6
Filtration.....	6
Temperature	6
Hydraulic fluids	6
Weight	6
Pressure drop.....	7
Connections.....	7
Hydraulic circuit diagram for hydraulic remote controlled valve	8
Hydraulic circuit diagram for electro hydraulic remote controlled valve	9
Connections [P09]	10
Counter pressure function [P10].....	10
Load signal system [P11]	10
Surface treatment (painted) [P12]	10
Prioritizing function [P16].....	10
Choice of spool.....	11
Spool function [P21, P41].....	11
Spool designations [P22, P42]	11
Area relationships [P25, P45].....	11
Spool actuators.....	12
PC, FPC	12
EC, FEC	13
Connector Type [P4]	13
Port relief valves [P32A, P32B, P52A, P52B]	14
Pressure settings [P33A, P33B, P53A, P53B].....	15
Load-hold check valve [P34A, P34B, P54A, P54B].....	15
Dimensional Drawings.....	16-23

[P00] refers to item numbers in customer specification.

Breadth of Line

Parker is the world's leading supplier of motion control components and system solutions serving the mobile, industrial and aerospace markets.

Parker is your single source for any hydraulic valve requirement. We provide a wide selection of open-centre and load-sense directional control valves for construction, off-highway, or on-highway applications. Many of our open-centre valves can be adapted and used as closed-centre constant-pressure, and constant-pressure unloaded valves. Each of these technologies offers unique features for improved machine performance over traditional, open-centre control valves.

When remote control is required, Parker provides a broad line of pilot controllers that are compact and pressure-matched with our control valves to provide consistent and optimized machine control. There are a variety of electric-switch handle options available for additional function control by the operator.

Parker's premier IQAN electronics packages range from simple stand-alone controllers to large, multiple CAN bus systems with colour displays. For example, IQAN interfaces with new electronic diesel engines over the SAE J1939 CAN bus.

Total Machine Motion Control

You can turn to us for all your mobile motion control solutions. We offer stand-alone valves, as well as custom-designed manifolds with integrated directional control valves.

No matter what type of system you choose, Parker solutions provide top-notch performance and reliability. Our systems are optimized to reduce complexity, size, cost, and fluid leakage. Therefore, working with Parker can significantly cut your machine-build time.

State-of-the-Art Manufacturing

Parker is committed to using lean manufacturing to eliminate waste while streamlining processes. Lean technology helps us meet customer request dates quickly and cost-effectively. We also rely on state-of-the-art equipment and technology, such as computer-aided machining, to ensure product quality.

We regularly invest in our ISO 9001 certified manufacturing facilities because we are committed to meeting all international standards for safety and quality.

In addition, Parker hydraulic valves and valve manifolds are fully tested and certified before being released to the customer. You can expect Parker hydraulic valves to work the first time, every time.

Customer Service

with A Global Reach

Parker's worldwide network of field sales engineers and Mobile Systems Engineers are the best in the business. A field sales engineer works closely with you, acting as a single point of contact to evaluate applications and design solutions. MSEs support field sales efforts by managing difficult design problems and complex circuit design.

You also benefit from Parker Mobile Technology Centers that are staffed by specially trained distributors who provide only the highest levels of customer service. These one-stop shops offer complete hydraulic systems design for mobile applications, as well as technology services such as diagnostics, troubleshooting, computer design, testing, and integration of electronic controls.

Finally, our thousands of dependable distributors are strategically located in your markets. They carry inventory to meet specific, local market needs, and they ensure that products arrive when and where they are needed. You can count on Parker distributors to minimize downtime.

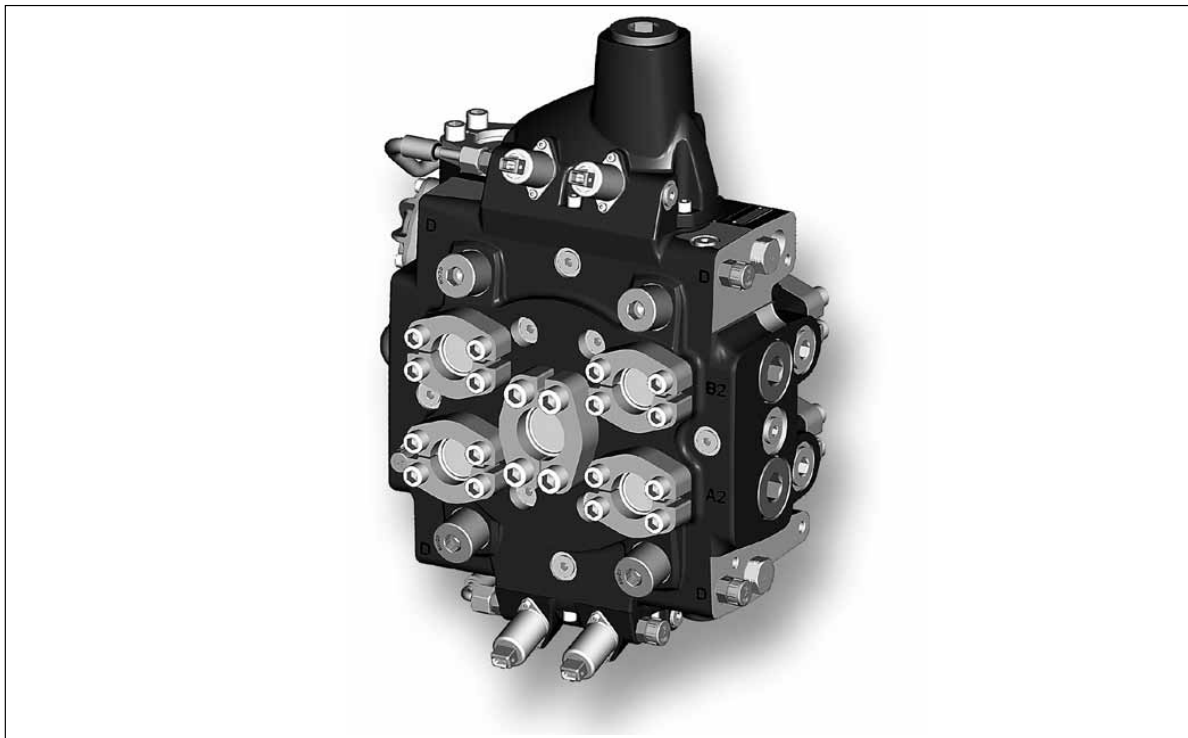

The M402LS is a directional valve intended for machines such as large wheeled-loaders, mine loaders, fork-lift trucks, etc. It is designed for use in closed-centre (LS) hydraulic systems with variable pumps, and is suitable for tough operating conditions.

Simple installation

Good machine design and the right hydraulic system gives a cost-effective installation, which in turn gives a competitive product. The pump and service ports in the M402LS are arranged in such a way that hosing and piping can be kept to an absolute minimum. The valve is equipped with double service ports at 180°, which eliminates T-connectors and gives the shortest and simplest path to the cylinders. This also enables dimensions to be kept small, since only half the flow passes through each service port.

Double pump connections, located optimally for easy installation, enable the simple connection of a second pump.

When the valve is mounted upright on the bottom plate good access for installation and service is obtained.

Safety

The M402LS is of robust construction. Many of the components are of the cartridge or module types, which facilitate servicing. It has both spool and poppet elements that give double safety in the case of hanging loads. The valve is also extremely well sealed, which prevents unintentional load sinking.

Design

The M402LS is a monoblock valve and is of LS design for variable pumps. It is cast in high quality material to enable it to withstand high pressures without deformation. The valve is of the spool type to give safe and precise regulation of the flow. To ensure tight sealing in the case of hanging loads, there is also a poppet element which, together with the spool, effectively blocks the hanging load. The poppet elements are controlled via a logic system and opened by pilot pressure. The poppet element also functions as a Load-hold check valve and as a prioritizing poppet on a port.

The gallery system in the valve housing is generously dimensioned to give minimal pressure drop. This enables low pressure regeneration in order to save energy and avoid cavitation.

Essential characteristics

- Excellent sealing: service ports closed by means of poppet valves.
- Not sensitive to temperature shocks: poppet-valve concept gives relatively large clearance between spool and bore.
- Good energy efficiency: low pressure drops for high function speeds; low energy consumption.
- Easy to install: designed with simple installation in mind.
- Optional float-position function: built-in, pressure-controlled float-position function eliminates the need for external components and signals.
- Great precision: low hysteresis gives precise control and good operator comfort.
- Pressure compensated lift and lowering functions
- Easy to service
- Long service life: efficient port-relief and anti-cavitation valves reduce the number of pressure peaks and cavitations in the system, thus prolonging the life of the machine.

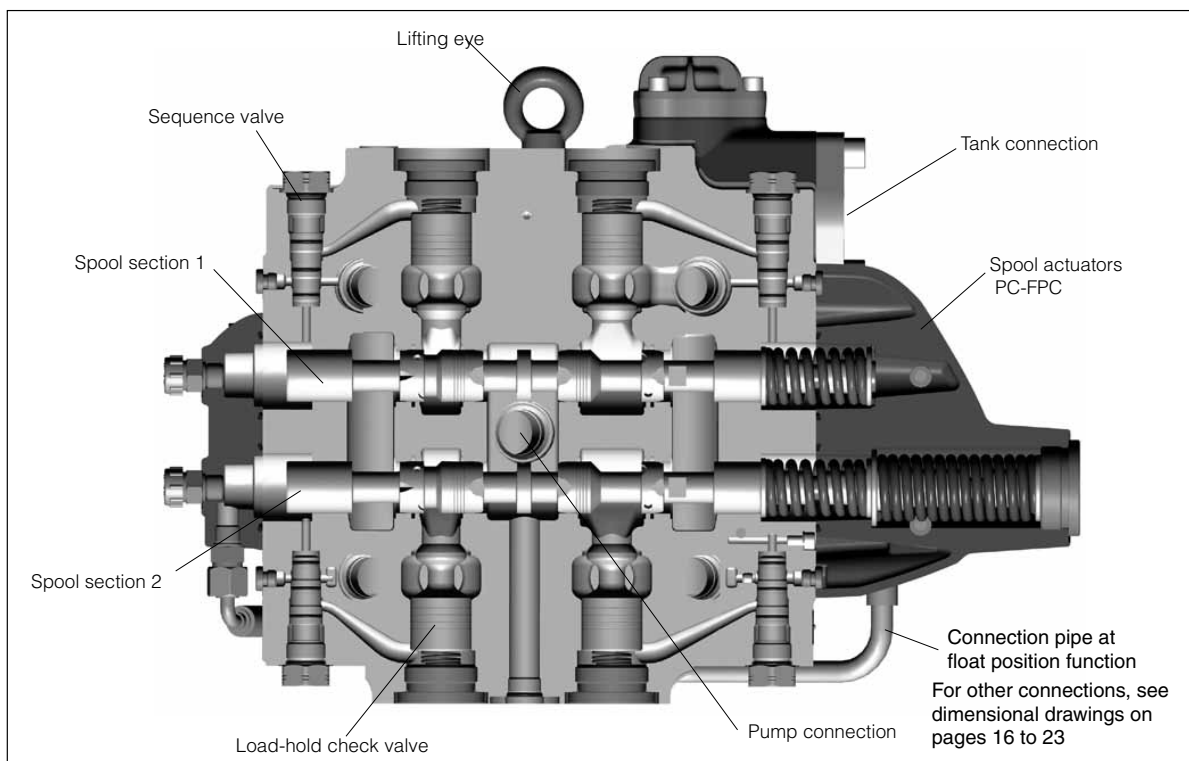

Pressure

Pump connection	max.	375 bar* (5440 psi)
Service port	max.	400 bar* (5800 psi)
Tank connection, static	max.	20 bar (290 psi)
Pressure in drain line	max.	1 bar (14.5 psi)

Flow rate (recommended)

Return from work port	1000 l/min (264 US gpm) at $\Delta p = 30$ bar (435 psi)
To work port	500 l/min** (132 US gpm) at $\Delta p = 20$ bar (290 psi)

Leakage from service port to tank

From A- or B-port: max. 50 cm³/min (1.22 in³/min) at 100 bar (1450 psi), oil temperature 50 °C (122 °F) and viscosity 30 mm²/s (cSt), fitted with Load-hold check valves.

Installation

While the valve can be mounted in any direction, it is best mounted upright (i.e. with lifting eye upwards) to give good access for servicing and enable simple handling. The base must be flat and stable to avoid stressing the valve on mounting.

Filtration

Filtration must be arranged so that Target Contamination Class 20/18/14 according to ISO 4406 is not exceeded. For the pilot circuit, Target Contamination Class 18/16/13 according to ISO 4406 must not be exceeded.

Temperature

Oil temperature, working range +20 to +90 °C*** (68 to 194 °F)
Cold start

The valve O-rings are of nitrile rubber as standard. In case of demands for high temperature resistance, please contact Parker for further information.

Hydraulic fluids

Best performance is obtained using mineral-base oil of high quality and cleanliness in the hydraulic system.

Hydraulic fluids of type HLP (DIN 51524), oil for automatic gearboxes Type A and engine oil type API CD can be used.

Viscosity, working range 15-380 mm²/s****

Technical information in this catalogue is applicable at an oil viscosity of 30 mm²/s and temperature of 50 °C (122 °F) using nitrile rubber seals.

* Stated pressures are maximum absolute shock pressures at 10-bar tank pressure.

** Depending on choice of spool

*** Product operating limits are broadly within the above range, but satisfactory operation within the specification may not be accomplished. Leakage and response will be affected when used at temperature extremes and it is up to the user to determine acceptability at these levels.

**** Performance efficiency will be reduced if outside the ideal values. These extreme conditions must be evaluated by the user to establish suitability of the products performance.

Weight

Valve complete with spool actuator for hydraulic servo and with float position option: 95 kg (210 lb).



Connections

Pump, tank and service-port connections are of the SAE flange type.

Valve block	M6 [P09]		U6 [P09]	
	Flange/Thread (M-version)		Flange/Thread (U-version)	
Connection (see pages 8, 9, 16-23)				
Pump, P	SAE 1 1/4" -H*	M14	SAE 1 1/4" -H*	M14
Service ports A1, B1, A2, B2	SAE 1" -H*	M12	SAE 1" -H*	M12
Tank, T	SAE 1 1/2" -S**	M12	SAE 1 1/2" -S**	M12
LS, Ps, psl, pl, pss, ps, D	-	M14x1,5	-	9/16-18 UNF
Additional connections A2, B2	-	1 1/16-12 UN	-	1 1/16-12 UN
Add. pump connection and gauge port T	-	M18x1,5	-	3/4-16 UNF
All other gauge ports	-	M14x1,5	-	9/16-18 UNF

Valve block	M3 [P09]		U3 [P09]	
	Flange/Thread (M-version)		Flange/Thread (U-version)	
Connection (see pages 8, 9, 16-23)				
Pump, P	SAE 1 1/4" -S**	M10	SAE 1 1/4" -S**	M10
Service ports A1, B1, A2, B2	SAE 1 1/4" -S**	M10	SAE 1 1/4" -S**	M10
Tank, T	SAE 1 1/2" -S**	M12	SAE 1 1/2" -S**	M12
LS, Ps, psl, pl, pss, ps, D	-	M14x1,5	-	9/16-18 UNF
Additional connections A2, B2	-	1 1/16-12 UN	-	1 1/16-12 UN
Add. pump connection and gauge port T	-	M18x1,5	-	3/4-16 UNF
All other gauge ports	-	M14x1,5	-	9/16-18 UNF

* High pressure (400 bar/6000 psi) ISO 6162
** Standard pressure (340 bar/3000 psi) ISO 6162

Pressure drop

Pressure drop measured with fully open spool intended for max. flow.

Δp (bar) Pressure drop - P1/P2 to service port A/B

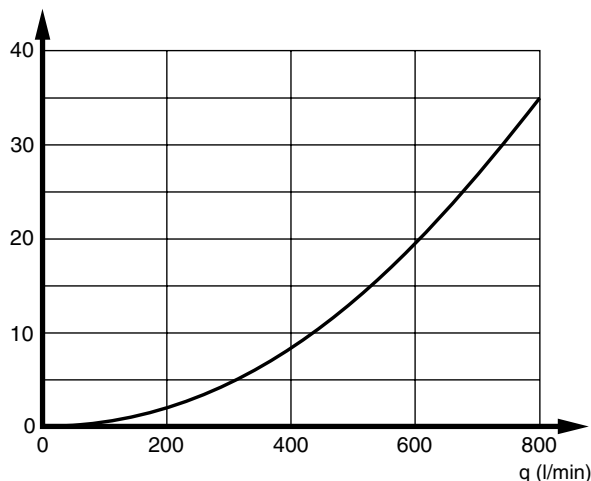

Pressure drop from pump connection P1/P2 to service port A/B.

Δp (bar) Pressure drop - service port to tank

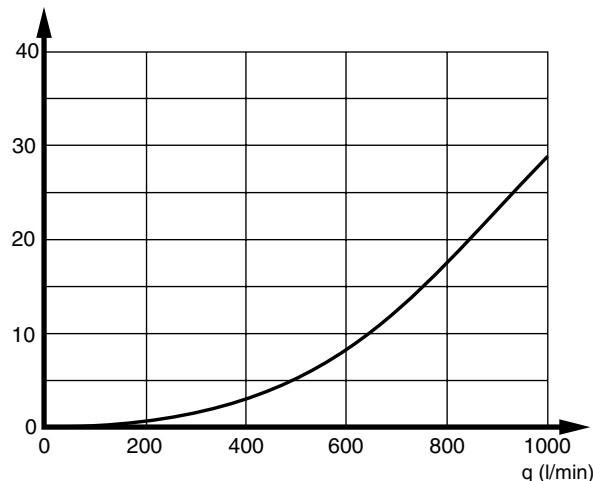

Pressure drop from service port A/B to tank connection T.



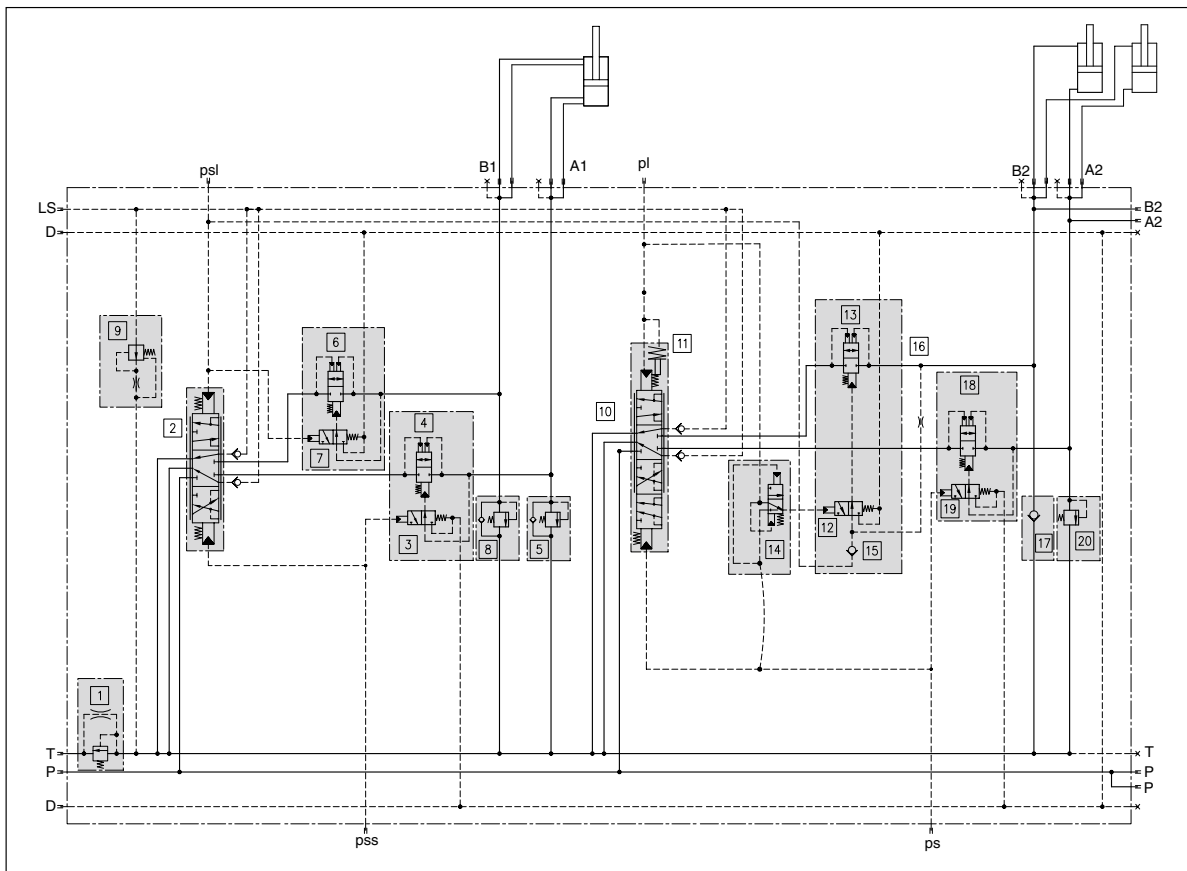

Hydraulic circuit diagram for hydraulic remote controlled valve

Pos.	Function	Pos.	Function
1	Counter pressure valve	11	Float position device
2	Section 1	12	Sequence valve, B2
3	Sequence valve, A1	13	Load-hold check valve, B2
4	Load-hold check valve, A1	14	Sequence spool float position
5	Port relief valve, A1	15	Check valve, priority
6	Load-hold check valve, B1	16	Restrictor, priority
7	Sequence valve, B1	17	Port relief valve, B2
8	Port relief valve, B1	18	Load-hold check valve, A2
9	LS drain	19	Sequence valve, A2
10	Section 2	20	Port relief valve, A2

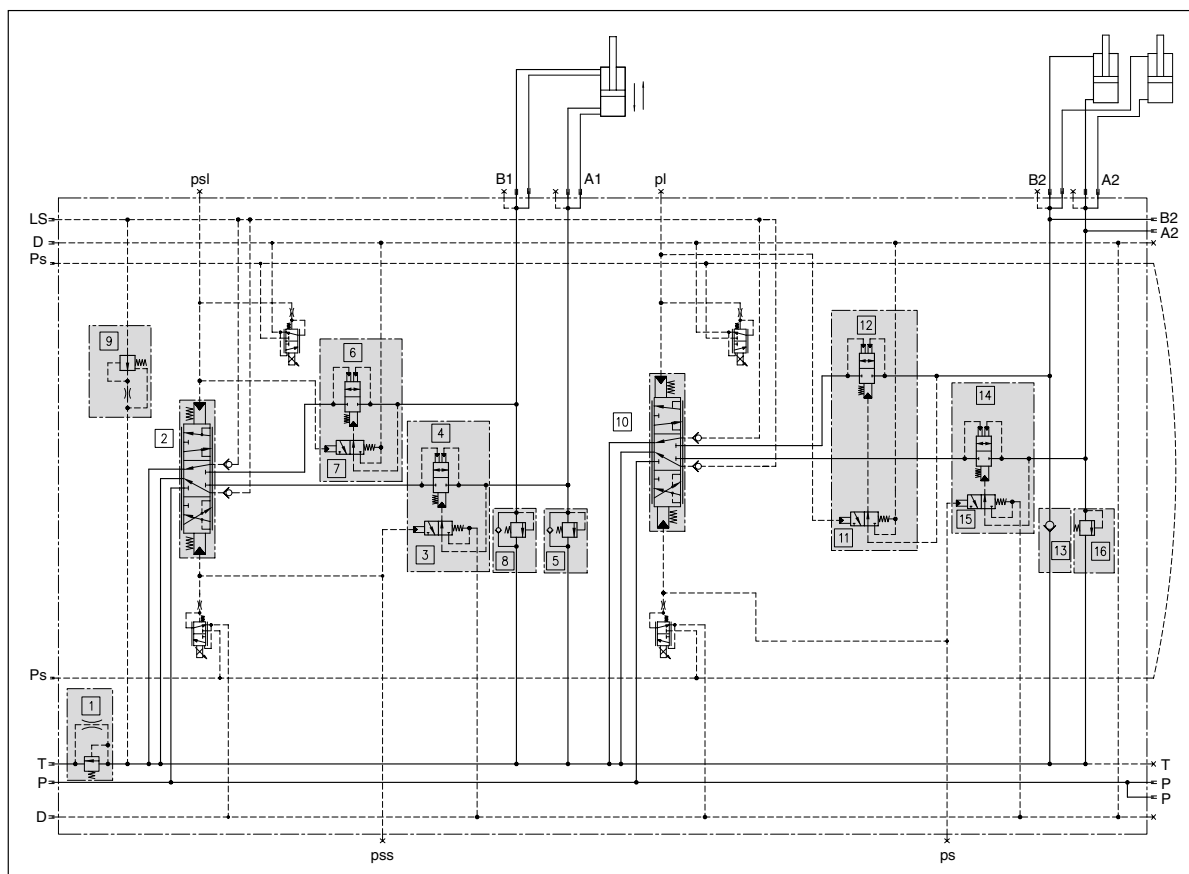

Hydraulic circuit diagram for electro hydraulic remote controlled valve

Pos.	Function	Pos.	Function
1	Counter pressure valve	11	Sequence valve, B2
2	Section 1	12	Load-hold check valve, B2
3	Sequence valve, A1	13	Port relief valve, B2
4	Load-hold check valve, A1	14	Load-hold check valve, A2
5	Port relief valve, A1	15	Sequence valve, A2
6	Load-hold check valve, B1	16	Port relief valve, A2
7	Sequence valve, B1		
8	Port relief valve, B1		
9	LS drain		
10	Section 2		

Technical Information

Mobile Directional Control Valve M402LS

Connections [P09]

Also see table on page 7.

M6	Connections with metric threads. SAE 6000 psi (according to ISO 6162)
M3	Connections with metric threads. SAE 3000 psi (according to ISO 6162)
U6	Connections with UNF threads. SAE 6000 psi (according to ISO 6162)
U3	Connections with UNF threads. SAE 3000 psi (according to ISO 6162)

Counter pressure function [P10]

The valve can be equipped with a counter pressure valve in the tank connection to ensure that oil from the cylinders is used primarily to replenish the system. This is possible thanks to the generous gallery dimensions and anti-cavitation valves. The valve is factory set.

MX	No counter pressure valve in tank gallery
MF5	Counter pressure valve set to 5 bar at 20 l/min
MF9	Counter pressure valve set to 9 bar at 20 l/min

Load signal system [P11]

When a spool is actuated, a signal corresponding to the weight of the load is directed to the LS connection. When both spools are actuated, the greater of the two signals is directed to the LS connection. To enable the signal to be changed, it is drained continuously to tank via the load-signal drainage (LD), at approx. 0.8 l/min.

LD	Load-signal drainage, set to 0.8-1.5 l/min
-----------	--

Surface treatment (painted) [P12]

P	Default value - unless otherwise stated valve will be supplied painted with a single coat of black primer
X	Unpainted

For full corrosion protection, the valve must be painted with an outer coat.

Prioritizing function [P16]

Section 1 can be pressure prioritized over section 2. This means that if there is a light load on section 2, heavier loads can be handled with section 1, e.g. so that an empty bucket can be tilted up at the same time as the main loading arms are lowered (prioritizing pressure approx. 50 bar). Prioritization is automatic and is controlled via pilot signal logic.

PR1	Port A1 has priority over port B2
/	Without prioritizing function (only M3 / U3 [P09])
A05	Prioritizing function blocked (only M6 / U6 [P09])

Δp (bar) Pressure drop over counter pressure valve

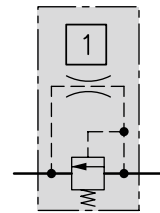
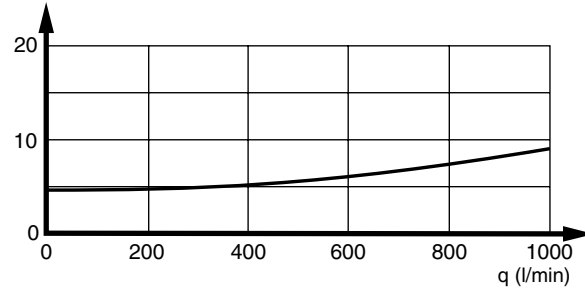

Counter pressure symbol. See also complete circuit diagram, page 8 and 9, pos. 1.

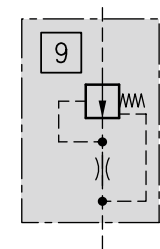

LS-drain

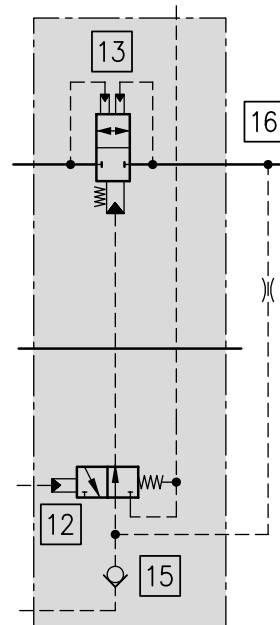

Priority function

Choice of spool

The spool is the most important link between the actions of the machine operator and the movement of the controlled function. Parker therefore goes to great lengths to optimize spools for different flows, load conditions and functions. This ongoing development work results in the continual introduction of new spools. For this reason, it is not practical to list in this catalogue the different spools available at any one time. For assistance in the choice of spool, we therefore ask you to contact Parker directly.

Spool function [P21, P41]

Parker spools are divided into different groups depending on their basic functions.

- D** Double-acting spool for, e.g. double-acting cylinder. Blocked in the neutral position.
- Db** Double-acting spool with drainage B to T, which prevents pressure build-up in the B-port in the neutral position. The spool is used as a double spool in combination with, e.g. an over-centre valve.
- Dm** Double-acting spool with drainage A to T and B to T, which prevents pressure build-up in the neutral position. The spool is used as a double-acting spool in combination with, e.g. an overcentre valve.
- EA** Single-acting spool for, e.g. single-acting cylinder. Blocked in the neutral position. Service port B blocked.
- EAa** Single-acting spool for, e.g. single-acting cylinder. Blocked in the neutral position. Service port B blocked. Drainage of service port A to tank.
- M** Double-acting spool for, e.g. hydraulic motor. Service ports connected to tank (float position) in the neutral position.
- F** Double-acting spool with fourth position in which both service ports are connected to tank (float position). Blocked in the neutral position.

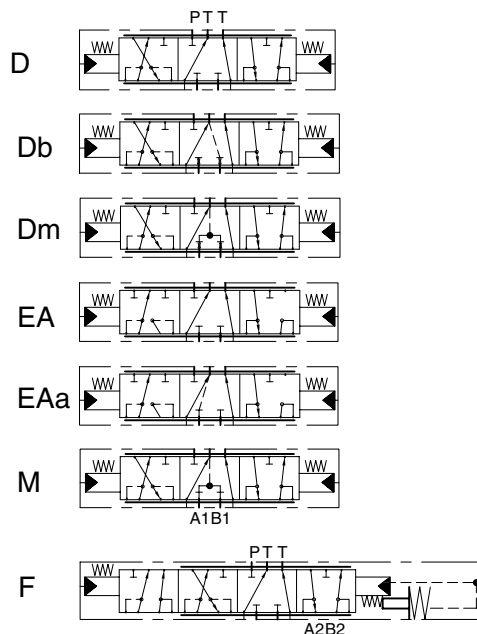

Spool designations [P22, P42]

Every spool is given a letter code, which is stamped on the spool. This facilitates identification of the spool when servicing is carried out.

Area relationships [P25, P45]

The area relationship for the section in question is calculated by dividing the cylinder area connected to the B-port by the cylinder area connected to the A-port. When the big side of the cylinder is connected to the A-port, the area relationship is less than 1. The area relationship for a motor is 1.

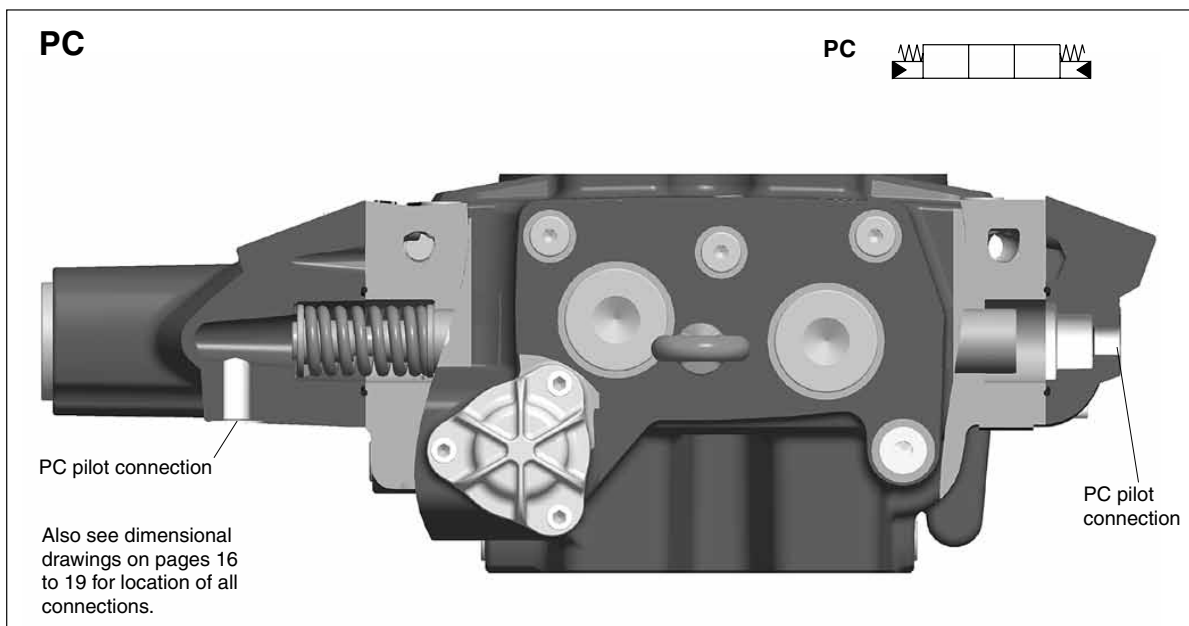

PC-PC [P27, P47]

Both section 1 and section 2 have hydraulic, proportionally controlled, spring-centred spool actuators. Best controlled by a PCL4 remote control valve (see catalogue HY17-8357/UK).

Breakaway pressure:* 6.5 bar
 Final pressure:* 18 bar
 (max 35 bar)

Connection thread: M14x1,5 or 9/16-18 UNF

PC-FPC [P27, P47]

Both section 1 and section 2 have hydraulic, proportionally controlled, spring-centred spool actuators with a fourth position for shifting the spool into the float position.

Breakaway pressure:* 6.5 bar
 Final pressure:* 18 bar
 Pressure for float position: min 24 bar
 (max 35 bar)

Connection thread: M14x1,5 or 9/16-18 UNF

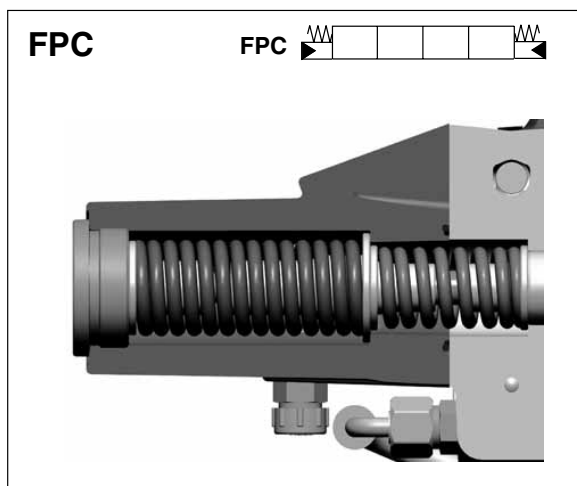

*
 The breakaway pressure refers to the pressure needed for the directional valve to open the connection "pump to work port". The final pressure is the lowest pressure needed to effect full actuation of a spool in the directional valve. With the FPC spool actuator, the float position is obtained by further increasing the final pressure from max. 18 bar to min. 24 bar. The foregoing data must be taken into consideration when choosing control units, since the opening pressure of the control unit must be lower than the breakaway pressure of the spool actuator in order to avoid jerky starting and stopping. However, the control unit's final pressure must be higher than the final pressure of the directional valve in order to ensure that the spools can be fully actuated.

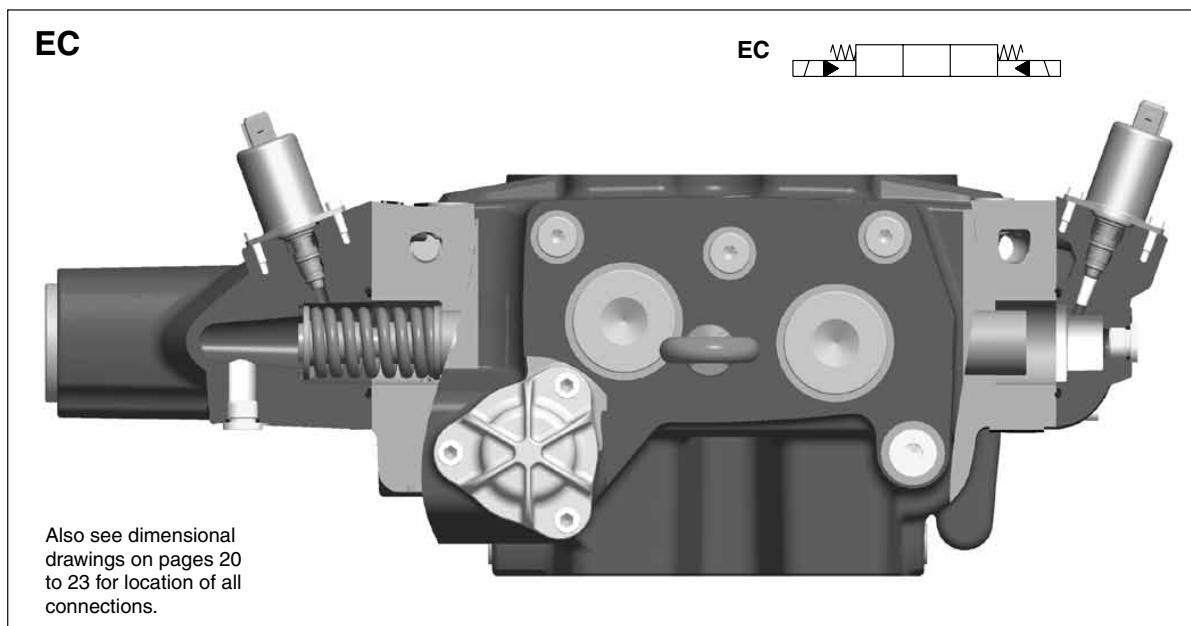

EC-EC [P27, P47]

Both section 1 and section 2 have electro-hydraulically, proportionally controlled, spring-centred spool actuators. The EC spool actuator is best controlled by means of a Parker electric remote-control system (see catalogue HY17-8368/UK).

Voltage	12 V	24 V
Breakaway current:*	max 660 mA	max 330 mA
Final current:*	min 1100 mA	min 570 mA

EC-FEC [P27, P47]

Both section 1 and section 2 have electro-hydraulically, proportionally controlled, spring-centred spool actuators. FEC is a proportionally controlled, spring-centred spool actuator with a fourth position for shifting the spool into the float position. The FEC spool actuator is best controlled by means of a Parker electric remote-control system (see catalogue HY17-8368/UK).

Voltage	12 V	24 V
Breakaway current:*	max 660 mA	max 330 mA
Final current:*	min 1100 mA	min 570 mA
Float position current:	max. 1450 mA min. 1320 mA	max. 730 mA min. 660 mA

Solenoid (PS25):	max 1450 mA, 100% ED	max 730 mA, 100% ED
------------------	-------------------------	------------------------

Coil resistance		
at +20 °C:	4,7 Ω	20,8 Ω
Inductance:	8,8 mH	36,1 mH
Tank pressure:	max 15 bar	max 15 bar
Connection thread:	M14x1,5 or 9/16-18 UNF	

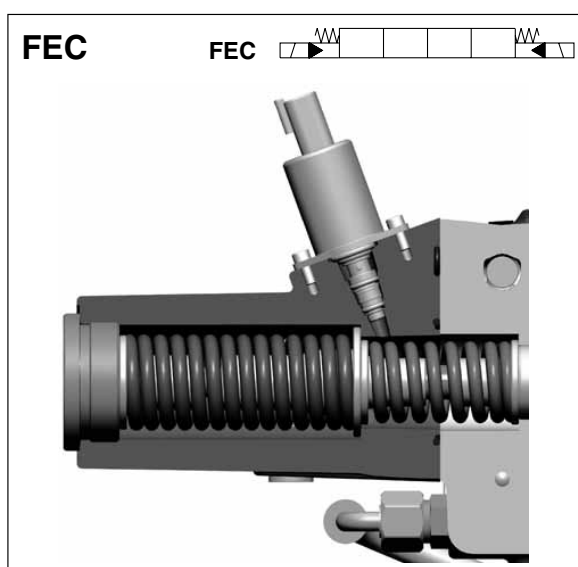

* The breakaway current refers to the current needed for the directional valve to open the connection "pump to work port". The final current is the lowest current needed to effect full actuation of a spool in the directional valve. With the FEC spool actuator, the float position is obtained by further increasing the final current, see table. The foregoing data must be taken into consideration when choosing control units, since the opening current of the control unit must be lower than the breakaway current of the spool actuator in order to avoid jerky starting and stopping. However, the control unit's final current must be higher than the final current of the directional valve in order to ensure that the spools can be fully actuated.

Connector Type [P04]

The connector of the solenoid is of type:

- A** AMP Junior-Timer type C
- D** Deutsch type DT06-2P

The connector must be ordered separately.



Port relief and/or anti-cavitation valve

In spool sections the cartridge can be used as a combined port-relief and anti-cavitation valve in the service ports to protect the valve and consumer from high system pressure and pressure surges.

The cartridge is a direct-acting pressure relief valve with a fast response and good pressure characteristic. The interchangeable cartridge is factory set. The make-up function enables oil to flow from the tank gallery to the service-port side in the event of negative pressure in the service ports, in order to prevent cavitation.

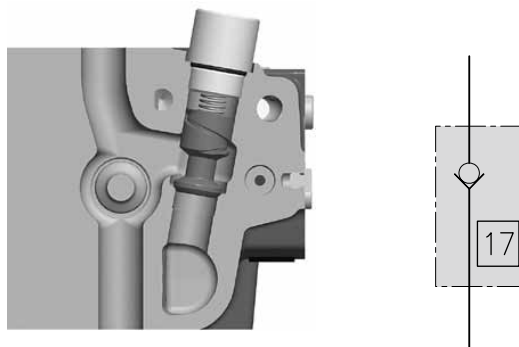

Anti-cavitation valve type N2.

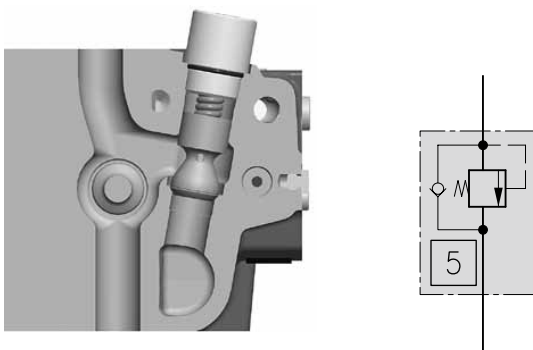

Port relief valve type PA.

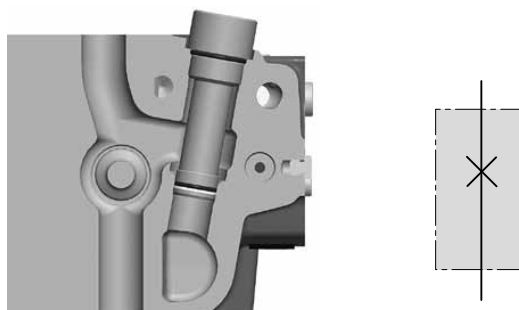

No port-relief or anti-cavitation valve fitted. Connection service port to tank gallery is blocked, type Y2.

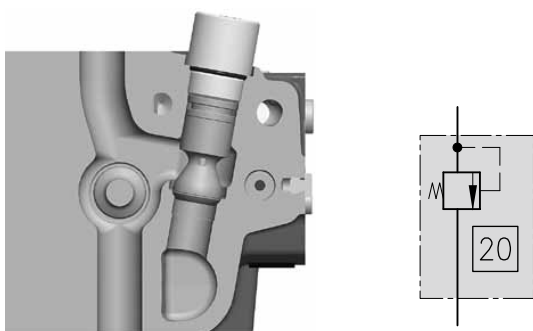

Port relief valve type PAY.

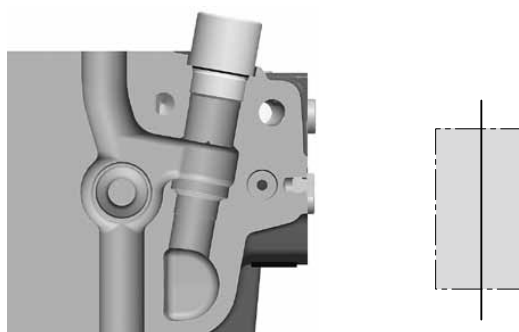

No port relief valve fitted. Service port connected to valve's tank gallery, type X2.

Technical Information

Mobile Directional Control Valve M402LS

Port relief valve [P32A, P32B, P52A, P52B]

- PA** Combined port-relief and anti-cavitation valve fitted. Valve is factory set.
- PAY** Port relief valve without anti-cavitation function fitted. Valve is factory set.
- N2** Only anti-cavitation function fitted.
- Y2** No port-relief or anti-cavitation valve fitted. Connection service port to tank gallery is blocked.
- X2** No port relief valve fitted. Service port connected to valve's tank gallery.

Pressure settings [P33A, P33B, P53A, P53B]

Setting range: 40 - 400 bar.

Pressure settings are made at a flow of 20 l/min through the valve.

Pressure settings are fixed. There are a large number of preset port relief valves to choose from.

Load-hold check valve [P34A, P34B, P54A, P54B]

The valve is normally equipped with pilot operated Load-hold check valves for operations that demand low leakage. These check valves are optional if the machine is equipped with outer Load-holding valves.

- N** Fitted with Load-hold check valve
- X3** Without Load-hold check valve

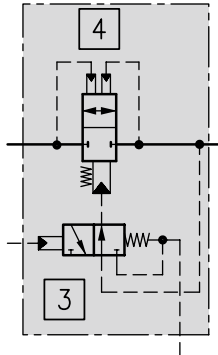

Connectors

Connectors are not included with spool actuators, and should be ordered separately as per the lists below or ordered from your local connector supplier.

Spool actuators EC, FEC

Suitable connectors for option A in pos [P04] are:
AMP Junior-Timer type C, 963040-3,
Bosch 1 928 402 404

Assembly kits complete with pins and seals can be ordered on following kit numbers:

1 off	393000K822
10 off	393000K825
50 off	393000K826
100 off	393000K827

For more information, see catalogue HY17-8558/UK.

Suitable connectors for option D in pos [P04] are:
Deutsch type DT06-2S

Δp (bar) Port relief valve characteristics

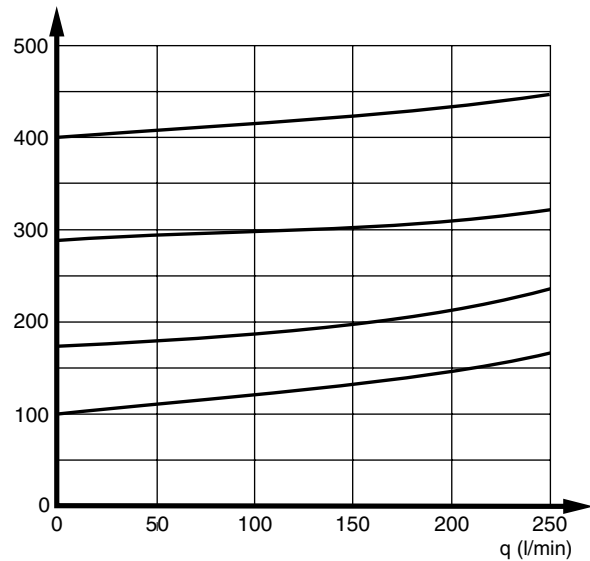

Δp (bar) Anti-cavitation characteristics

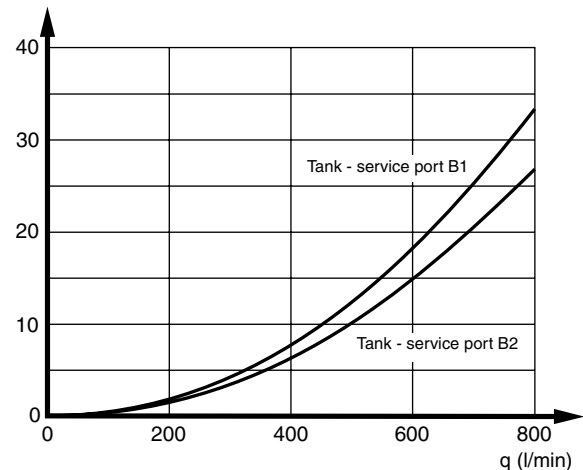

**Hydraulic remote controlled (PC - PC)
M3 and U3**

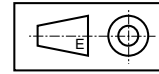

mm (inch)

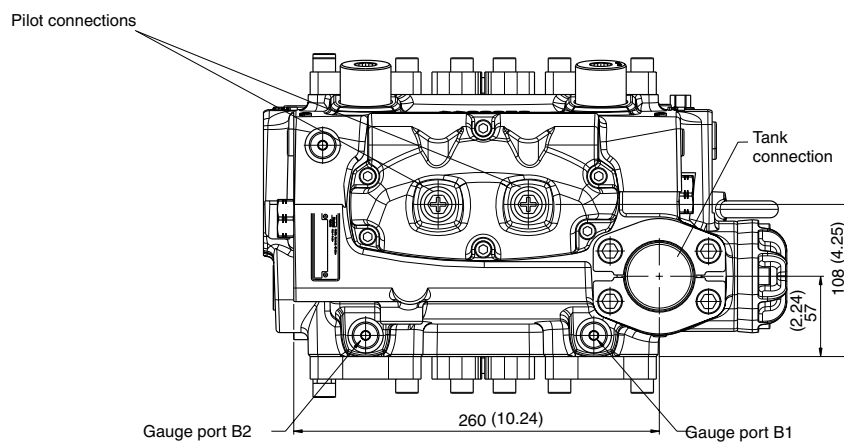
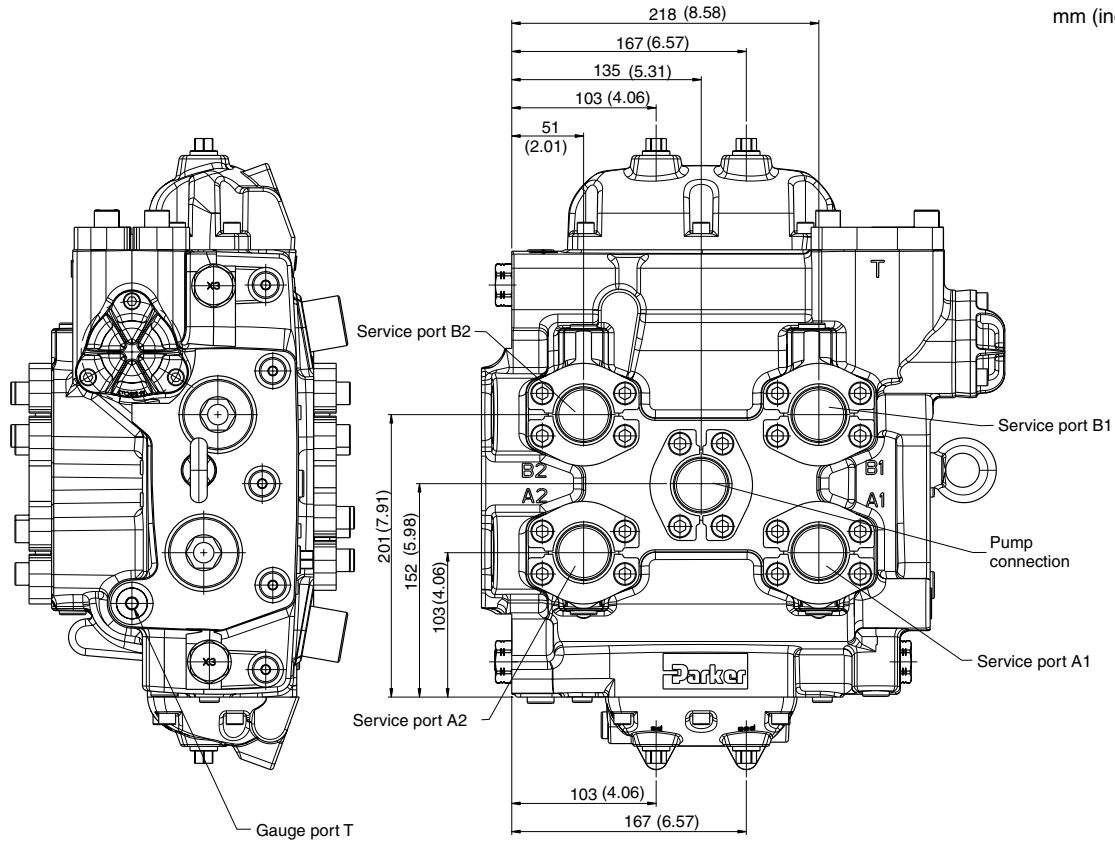

**Hydraulic remote controlled (PC - PC)
M3 and U3**

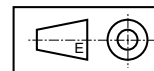

mm (inch)

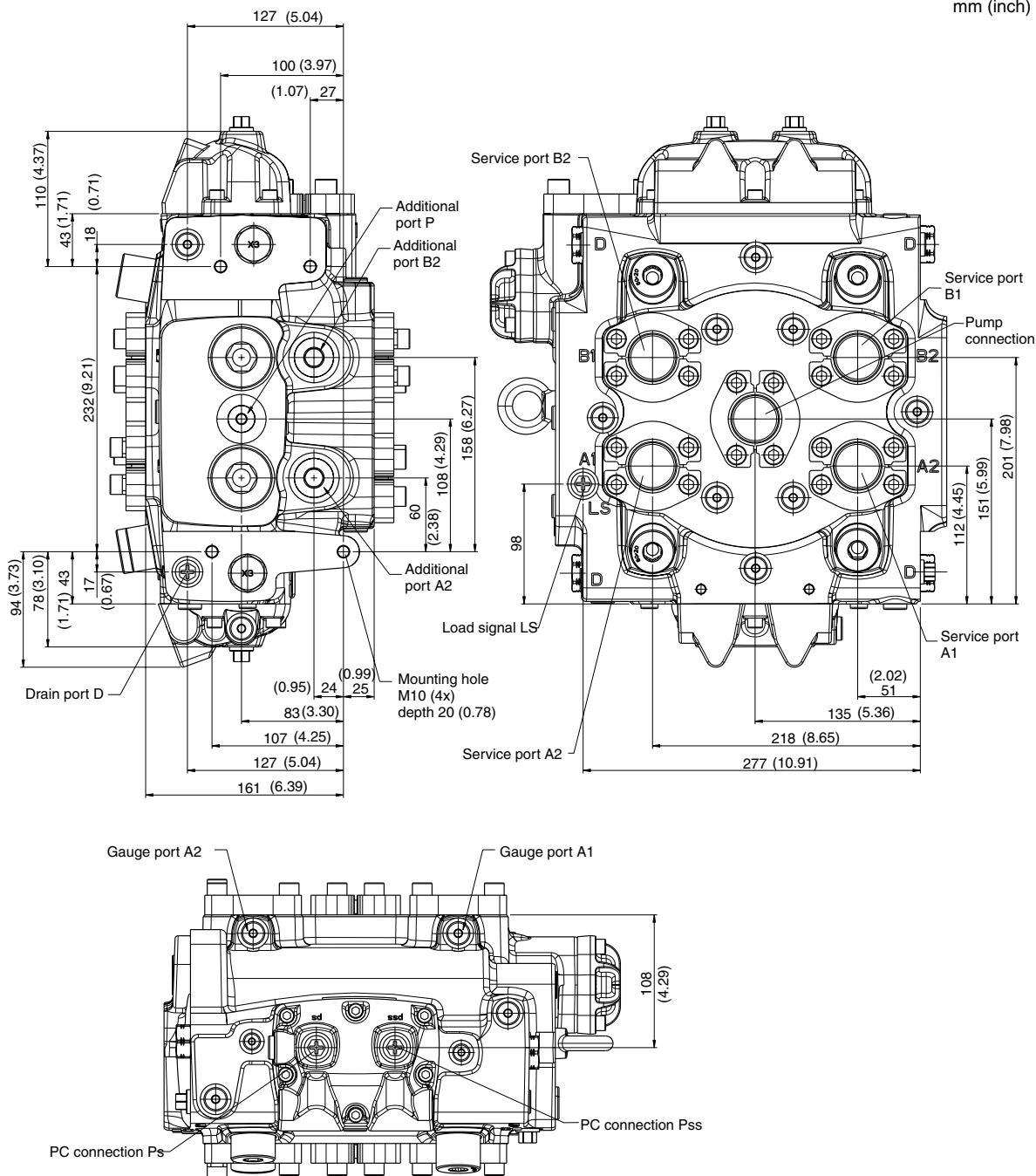

**Hydraulic remote controlled
(PC - FPC) / (PC - PC)
M6 and U6**

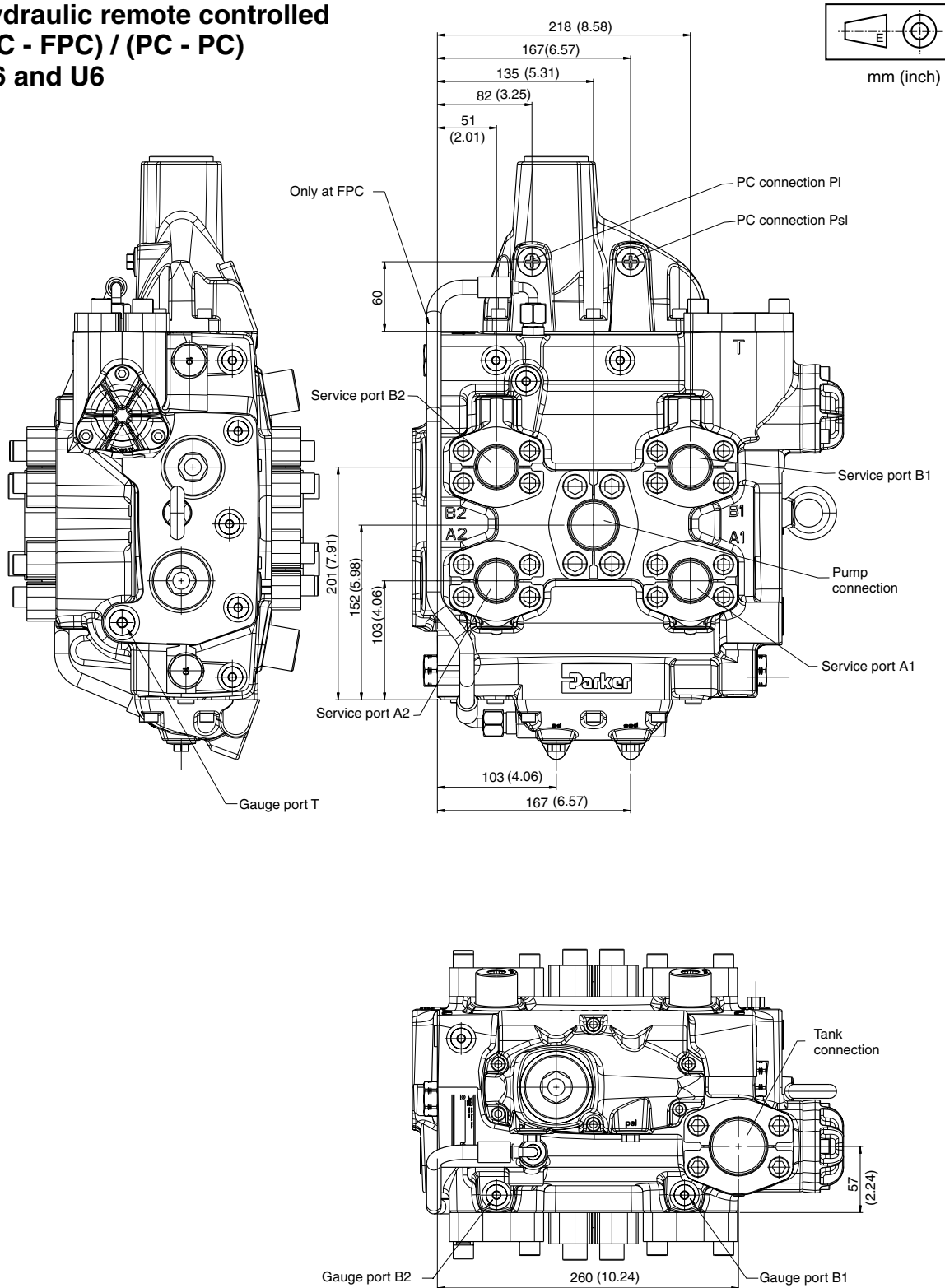

**Hydraulic remote controlled (PC - FPC) / (PC - PC)
M6 and U6**

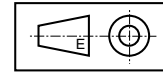

mm (inch)

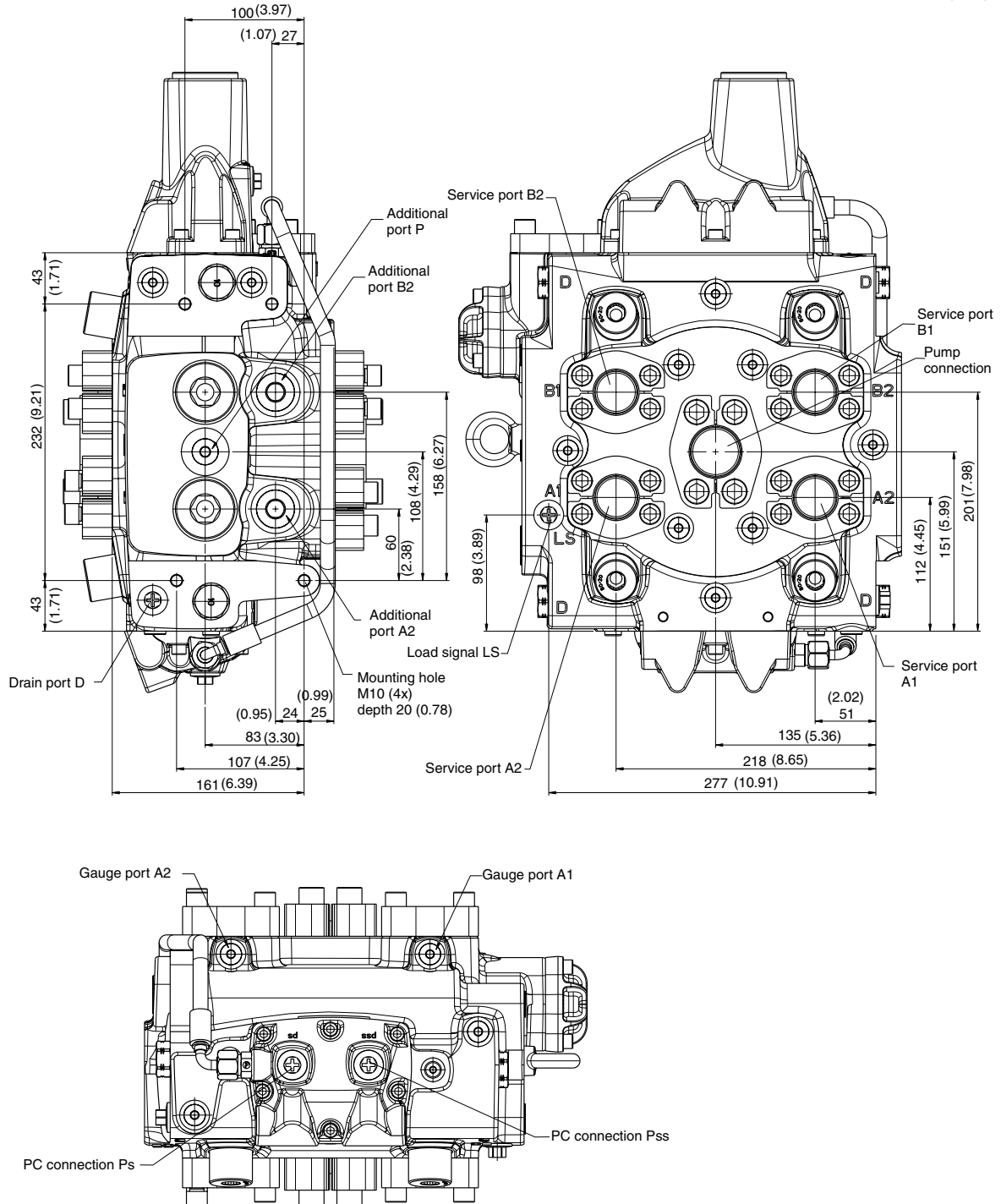

**Electro-hydraulic remote controlled (EC - EC)
M3 and U3**

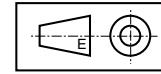

mm (inch)

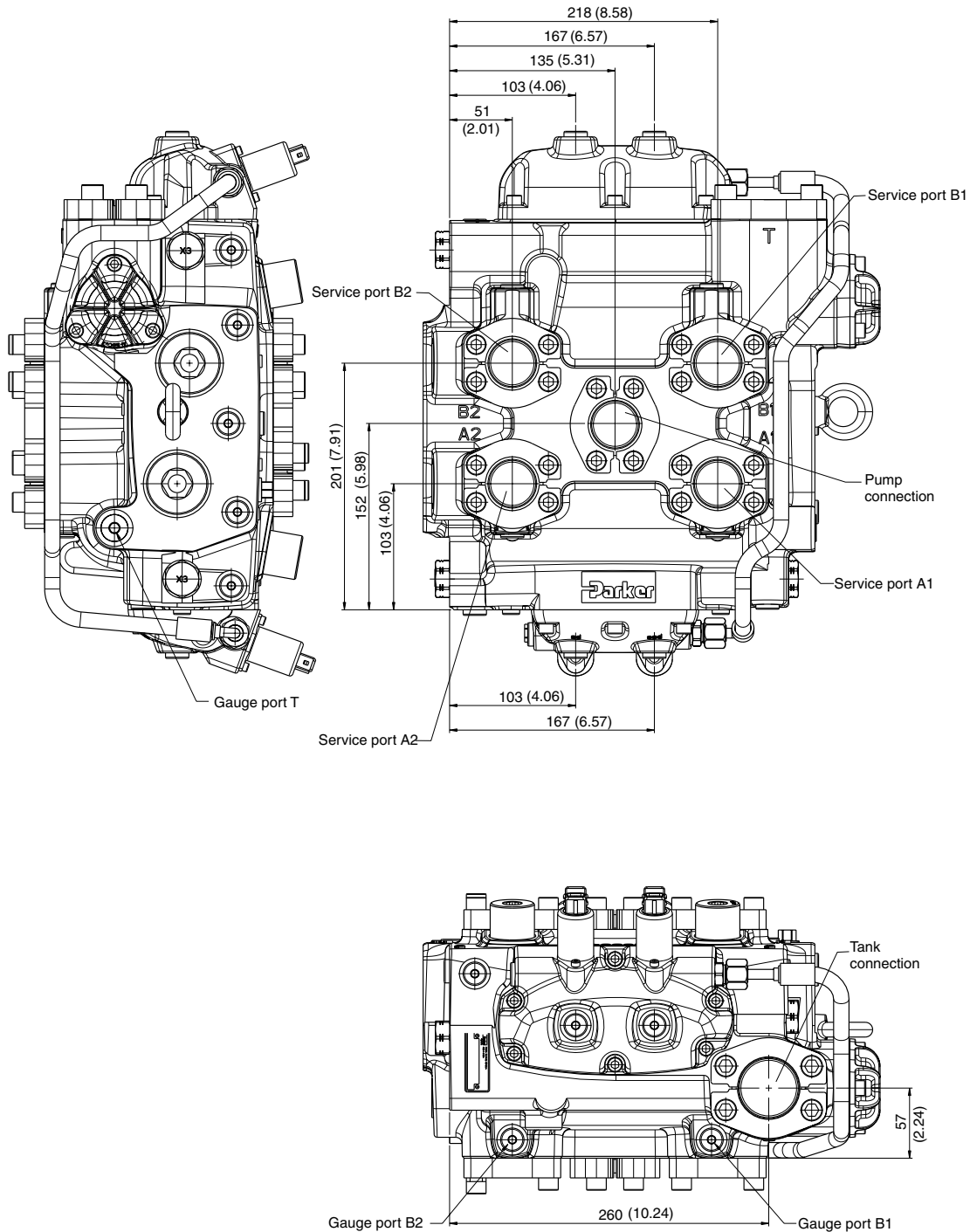

**Electro-hydraulic remote controlled (EC - EC)
M3 and U3**

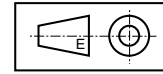

mm (inch)

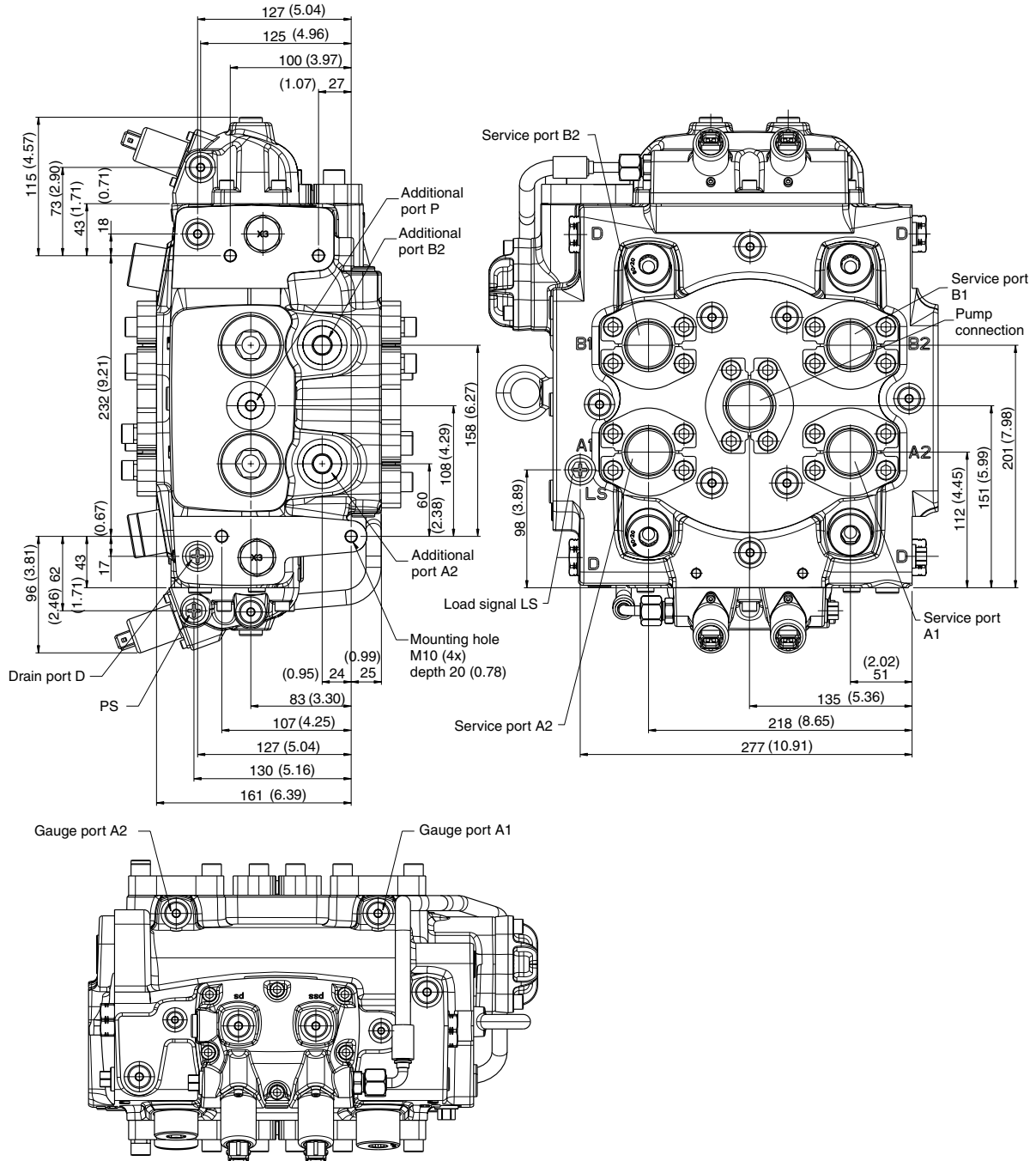

**Electro-hydraulic remote controlled
(EC - FEC) / (EC - EC) M6 and U6**

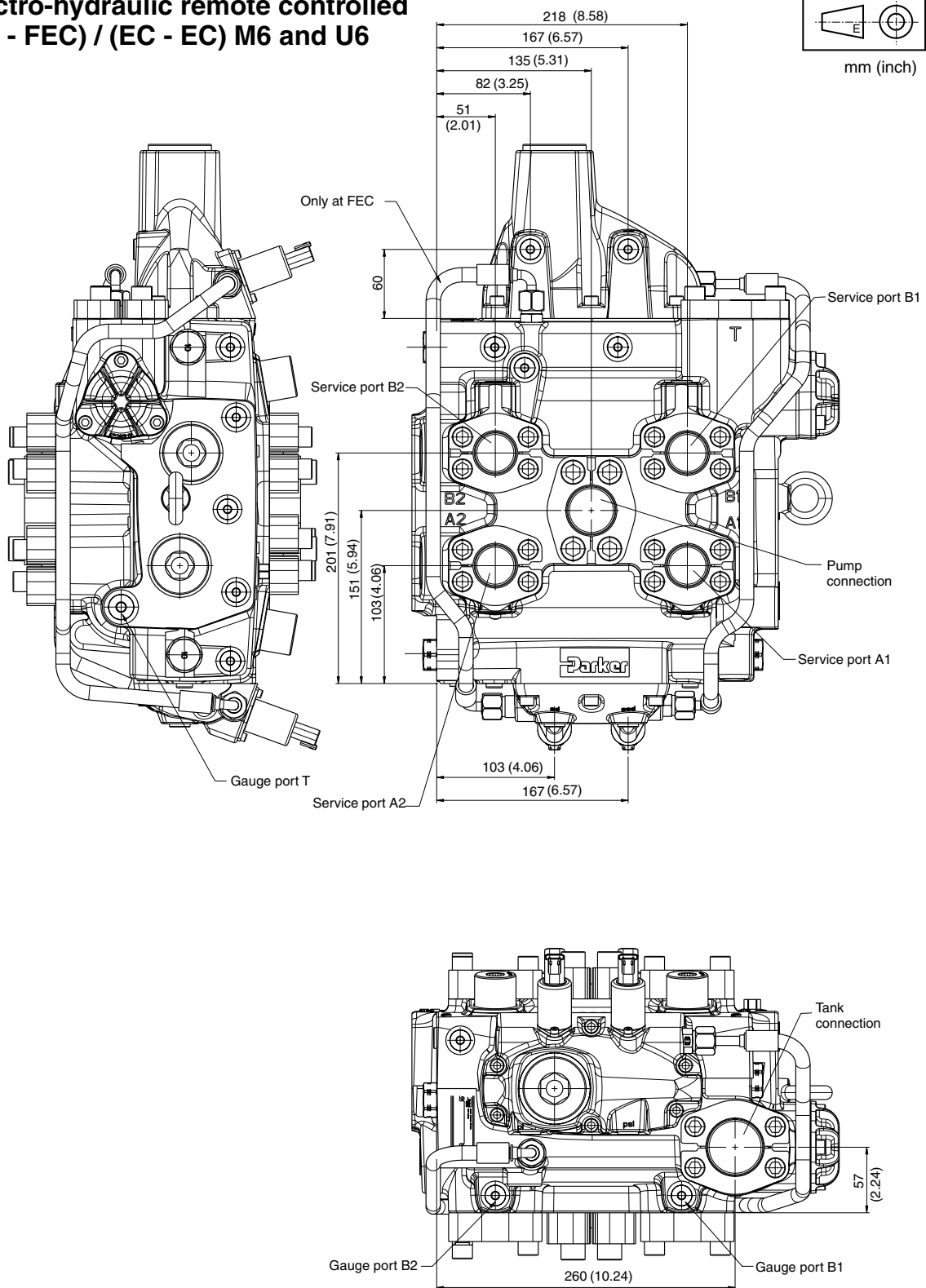

Electro-hydraulic remote controlled (EC - FEC) / (EC - EC) M6 and U6

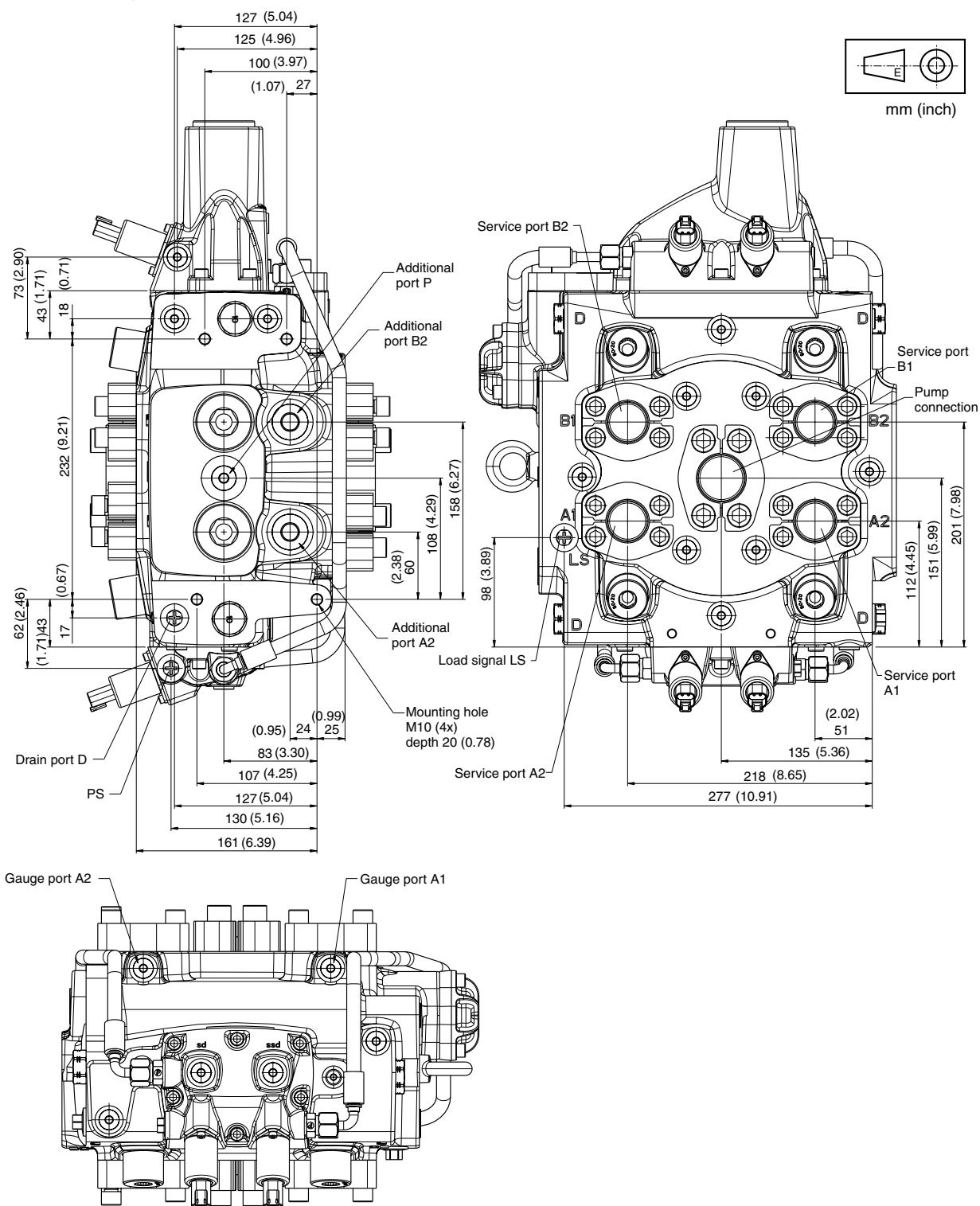

Parker Worldwide

Europe, Middle East, Africa

AE – United Arab Emirates, Dubai
Tel: +971 4 8127100
parker.me@parker.com

AT – Austria, Wiener Neustadt
Tel: +43 (0)2622 23501-0
parker.austria@parker.com

AT – Eastern Europe, Wiener Neustadt
Tel: +43 (0)2622 23501 900
parker.easteurope@parker.com

AZ – Azerbaijan, Baku
Tel: +994 50 22 33 458
parker.azerbaijan@parker.com

BE/LU – Belgium, Nivelles
Tel: +32 (0)67 280 900
parker.belgium@parker.com

BG – Bulgaria, Sofia
Tel: +359 2 980 1344
parker.bulgaria@parker.com

BY – Belarus, Minsk
Tel: +375 17 209 9399
parker.belarus@parker.com

CH – Switzerland, Etoy
Tel: +41 (0)21 821 87 00
parker.switzerland@parker.com

CZ – Czech Republic, Klecany
Tel: +420 284 083 111
parker.czechrepublic@parker.com

DE – Germany, Kaarst
Tel: +49 (0)2131 4016 0
parker.germany@parker.com

DK – Denmark, Ballerup
Tel: +45 43 56 04 00
parker.denmark@parker.com

ES – Spain, Madrid
Tel: +34 902 330 001
parker.spain@parker.com

FI – Finland, Vantaa
Tel: +358 (0)20 753 2500
parker.finland@parker.com

FR – France, Contamine s/Arve
Tel: +33 (0)4 50 25 80 25
parker.france@parker.com

GR – Greece, Athens
Tel: +30 210 933 6450
parker.greece@parker.com

HU – Hungary, Budaoers
Tel: +36 23 885 470
parker.hungary@parker.com

IE – Ireland, Dublin
Tel: +353 (0)1 466 6370
parker.ireland@parker.com

IT – Italy, Corsico (MI)
Tel: +39 02 45 19 21
parker.italy@parker.com

KZ – Kazakhstan, Almaty
Tel: +7 7273 561 000
parker.easteurope@parker.com

NL – The Netherlands, Oldenzaal
Tel: +31 (0)541 585 000
parker.nl@parker.com

NO – Norway, Asker
Tel: +47 66 75 34 00
parker.norway@parker.com

PL – Poland, Warsaw
Tel: +48 (0)22 573 24 00
parker.poland@parker.com

PT – Portugal, Leca da Palmeira
Tel: +351 22 999 7360
parker.portugal@parker.com

RO – Romania, Bucharest
Tel: +40 21 252 1382
parker.romania@parker.com

RU – Russia, Moscow
Tel: +7 495 645-2156
parker.russia@parker.com

SE – Sweden, Spånga
Tel: +46 (0)8 59 79 50 00
parker.sweden@parker.com

SK – Slovakia, Banská Bystrica
Tel: +421 484 162 252
parker.slovakia@parker.com

SL – Slovenia, Novo Mesto
Tel: +386 7 337 6650
parker.slovenia@parker.com

TR – Turkey, Istanbul
Tel: +90 216 4997081
parker.turkey@parker.com

UA – Ukraine, Kiev
Tel: +380 44 494 2731
parker.ukraine@parker.com

UK – United Kingdom, Warwick
Tel: +44 (0)1926 317 878
parker.uk@parker.com

ZA – South Africa, Kempton Park
Tel: +27 (0)11 961 0700
parker.southafrica@parker.com

North America

CA – Canada, Milton, Ontario
Tel: +1 905 693 3000

US – USA, Cleveland (industrial)
Tel: +1 216 896 3000

US – USA, Elk Grove Village (mobile)
Tel: +1 847 258 6200

Asia Pacific

AU – Australia, Castle Hill
Tel: +61 (0)2-9634 7777

CN – China, Shanghai
Tel: +86 21 2899 5000

HK – Hong Kong
Tel: +852 2428 8008

ID – Indonesia, Tangerang
Tel: +62 21 7588 1906

IN – India, Mumbai
Tel: +91 22 6513 7081-85

JP – Japan, Fujisawa
Tel: +81 (0)4 6635 3050

KR – South Korea, Seoul
Tel: +82 2 559 0400

MY – Malaysia, Shah Alam
Tel: +60 3 7849 0800

NZ – New Zealand, Mt Wellington
Tel: +64 9 574 1744

SG – Singapore
Tel: +65 6887 6300

TH – Thailand, Bangkok
Tel: +662 717 8140

TW – Taiwan, New Taipei City
Tel: +886 2 2298 8987

VN – Vietnam, Ho Chi Minh City
Tel: +84 8 3999 1600

South America

AR – Argentina, Buenos Aires
Tel: +54 3327 44 4129

BR – Brazil, Cachoeirinha RS
Tel: +55 51 3470 9144

CL – Chile, Santiago
Tel: +56 2 623 1216

MX – Mexico, Toluca
Tel: +52 72 2275 4200

Ed. 2013-06-01

EMEA Product Information Centre

Free phone: 00 800 27 27 5374

(from AT, BE, CH, CZ, DE, DK, EE, ES, FI, FR, IE, IL, IS, IT, LU, MT, NL, NO, PL, PT, RU, SE, SK, UK, ZA)

US Product Information Centre

Toll-free number: 1-800-27 27 537

www.parker.com

Your local authorized Parker distributor

