

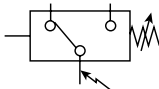

# SCPSD



## Features

- **Stainless Steel or Ceramic Diaphragms**
- **UL Listed and CE Marked**
- **Pressure Ranges**
  - 14.7 to 250 PSI ..... 0 to 3000 PSI
  - 0 to 1000 PSI ..... 0 to 5000 PSI
  - 0 to 2000 PSI ..... 0 to 9000 PSI
- **Sensor Outputs**
  - 2 PNP Open Collector Transistor Output, 30 VDC, 100mA
  - Optional Additional Current, 4 to 20mA
- **Selectable Units of Measure**  
PSI, bar, Mpa
- **Output Response Time Less than 5.0ms**
- **Error Message**
- **Polarity Protected**
- **Short Circuit Protected**
- **4 Digit LED**
- **Display Swivels 290°**

## SCPSD Programming Options

Outputs Change N.O. / N.C.	✓
Units of Measure change	✓
EZY Mode	
Hysteresis Mode	✓
Window Comparator Mode	
Auto Teach Mode	
Auto Surveillance Mode	
Display Refresh Settings	✓
Output Response Time	✓
Display Peak / Bottom Difference Value	✓
Special Display Features	
Lockout Option	
Peak Value at a Touch	
Bottom Value at a Touch	
Zero Reset	✓
Red / Green LED Display Options	
Peak Surveillance Mode	
Energy Savings Mode	✓
Scan Mode	
Password Lockout	✓
Error Output Mode	✓
Setting of Decimal Point	✓



## SCPSD Ordering Numbers

Pressure Range	Port Size	Output Circuit	Electrical Connector	Part Number
-14.7 to 100 PSI	7/6-20 UNF-2b (SAE-4)	( 2 ) PNP	M12, 4 Pin	SCPSPD-0100P-0727
-14.7 to 100 PSI	7/6-20 UNF-2b (SAE-4)	( 1 ) PNP with 4-20MA	M12, 4 Pin	<b>SCPSPD-0100P-1727</b>
-14.7 to 250 PSI	7/6-20 UNF-2b (SAE-4)	( 2 ) PNP	M12, 4 Pin	<b>SCPSPD-0250P-0727</b>
-14.7 to 250 PSI	7/6-20 UNF-2b (SAE-4)	( 1 ) PNP with 4-20MA	M12, 4 Pin	<b>SCPSPD-0250P-1727</b>
0 to 1000 PSI	7/6-20 UNF-2b (SAE-4)	( 2 ) PNP with 4-20MA	M12, 5 Pin	<b>SCPSPD-1000P-1725</b>
0 to 1000 PSI	7/6-20 UNF-2b (SAE-4)	( 1 ) PNP with 4-20MA	M12, 4 Pin	<b>SCPSPD-1000P-1727</b>
0 to 3000 PSI	7/6-20 UNF-2b (SAE-4)	( 2 ) PNP	M12, 4 Pin	<b>SCPSPD-3000P-0727</b>
0 to 3000 PSI	7/6-20 UNF-2b (SAE-4)	( 1 ) PNP with 4-20MA	M12, 4 Pin	<b>SCPSPD-3000P-1727</b>
0 to 3000 PSI	7/6-20 UNF-2b (SAE-4)	( 2 ) PNP with 4-20MA	M12, 5 Pin	<b>SCPSPD-3000P-1725</b>
0 to 5000 PSI	7/6-20 UNF-2b (SAE-4)	( 2 ) PNP	M12, 4 Pin	SCPSPD-5000P-0727
0 to 5000 PSI	7/6-20 UNF-2b (SAE-4)	( 1 ) PNP with 4-20MA	M12, 4 Pin	<b>SCPSPD-5000P-1727</b>
0 to 5000 PSI	7/6-20 UNF-2b (SAE-4)	( 2 ) PNP with 4-20MA	M12, 5 Pin	<b>SCPSPD-5000P-1725</b>
0 to 9000 PSI	7/6-20 UNF-2b (SAE-4)	( 2 ) PNP	M12, 4 Pin	SCPSPD-9000P-0727
0 to 9000 PSI	7/6-20 UNF-2b (SAE-4)	( 1 ) PNP with 4-20MA	M12, 4 Pin	SCPSPD-9000P-1727
-1 to 16 Bar	1/4 BSPP Male	( 2 ) PNP	M12, 4 Pin	<b>SCPSPD-016-04-17</b>
-1 to 16 Bar	1/4 BSPP Male	( 2 ) PNP with 4-20ma	M12, 5 Pin	<b>SCPSPD-016-14-15</b>
0 to 250 Bar	1/4 BSPP Male	( 2 ) PNP	M12, 4 Pin	<b>SCPSPD-250-04-17</b>
0 to 250 Bar	1/4 BSPP Male	( 2 ) PNP with 4-20ma	M12, 5 Pin	<b>SCPSPD-250-14-15</b>
0 to 600 Bar	1/4 BSPP Male	( 2 ) PNP	M12, 4 Pin	SCPSPD-600-04-17
0 to 600 Bar	1/4 BSPP Male	( 2 ) PNP with 4-20ma	M12, 5 Pin	SCPSPD-600-14-15

## Specifications

Pressure Code	0100	0250	016	1000	3000	5000	9000	250	600
Units of Measure	PSI ,bar, MPA								
Measure Range ( PSI, bar )	-14.7 to 100	-14.7 to 250	-1 to 16	0 to 1000	0 to 3000	0 to 5000	0 to 9000	0 to 250	0 to 600
Overload Pressure ( PSI, bar )	360	725	40	2900	7250	11600	21750	500	1200
Burst Pressure ( PSI, bar )	360	725	50	11600	17400	24650	31900	1200	2200
Sensing Element	Ceramic			Stainless Steel					
Parts in Contact with Media	Stainless Steel 1.4404			Stainless Steel 1.4404, 1.4542, NBR*					
	Ceramic AL203, NBR*								
	*FPDM, EPDM Special Request								
Switch Cycles	>100 Million								
Output Response Time	< 10ms								
Power Supply	15 to 30VDC, Class 2 Power Supply								
Short Circuit Protection	Yes, 2.4 Amp / Open Collector Output								
Reverse Polarity Protection	Yes								
Overload Protection	Yes								
Current Consumption	< 100mA								
Output Circuit	2 PNP (Sourcing) Open Collector Transistor								
Analog Output	0/4...20mA, Programmable, freely scaleable								
Output Functions	Hysteresis, Window Comparator								
Switching Voltage	-1.5VDC								
Maximum Current Output	1A with 2 Open Collector Outputs, .5A per Output								
Accuracy	± 0.5% F.S. Typ., ± 1% Max.								
Repeatability	± 0.25% F.S.								
Display Accuracy	± 0.5% F.S. Typ., ± 1 Digit								
Thermal Error Max.	±0.03% F.S. at -4 to 185°F (-20 to 85°C)								
Material	Pressure Die-cast Zinc Z 410: Surface-finishing								
Display Material	Polyester								
General Protection	IP 67, EN60529, UL, CE Marked, EMC-EN50082-2 Class B, EN 50081-2								
Temperature Range of Media	-4 to 185°F (-20 to 85°C)								
Ambient Temperature Range	-4 to 185°F (-20 to 85°C)								
Storage Temperature	-40 to 212°F (-40 to 100°C)								
Display	4-Digit, 7-Segment LED, Red, 9mm Height								
Tightening Torque	35Nm								
Vibration Resistance	20G, 10 to 500Hz, IEC60068-2-6								
Shock Resistance	50 G, XYZ, 11ms, IEC60068-2-29								
Mass	10.6 oz. (300g)								



## Internal Circuit

**M12, 4-Pin, (2) PNP Outputs**

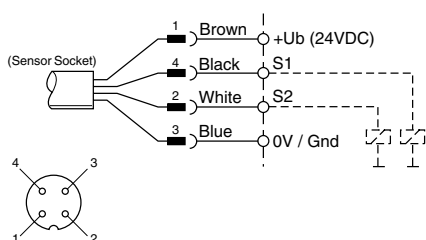

**M12, 5-Pin, (2) PNP Outputs with 4 to 20mA Analog**

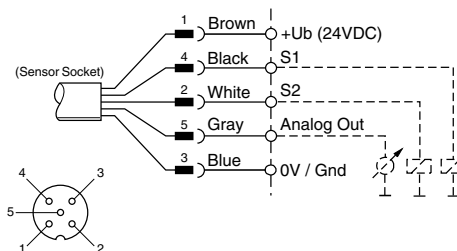

**M12, 4-Pin, (1) PNP Output with 4 to 20mA Analog**

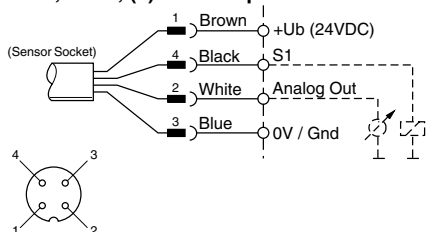

**Note:** M12, 5-Pin Female Cable Connector will fit on both M12, 4-Pin and 5-Pin Male Sensor Connector.

## Installation

### Mechanical:

**⚠ CAUTION: Install and de-install the SCPSD only when there is no pressure present.**

Attach the SCPSD to the appropriate process connection. Installation should be undertaken only with a 22mm, across flats spanner. Ensure that the digital display is placed in the best viewing position by using the rotational housing adjustment. Turn the SCPSD manually to the required position. Maximum 290°.

Excessive turning beyond the easily detectable end stop will lead to damage.

The housing can be attached:

- with self-tapping screws into two blind holes at the back of the housing
- with the mounting plate provided
- with cable ties

### Electrical:

**⚠ CAUTION: The SCPSD may be installed only by a qualified electrician in accordance with the respective national and international regulations.**

Protect the SCPSD from electromagnetic influences and over-voltages.

Optional installation tips which are shown by experience to reduce the influence of interference:

- Use shorter cables
- Avoid short distances between connecting leads and power consuming devices and interference generating electrical and electronic equipment
- Use free running diodes

Avoid static and dynamic over-pressures which exceed the specified overload pressure. Even when the overload pressure is exceeded only for a short time the SCPSD may be damaged. Parker SensoControl diagnostic systems are recommended for measuring pressure peaks exactly.

If there is a danger of excessively high pressure peaks, it is recommended to:

- use an SCPSD with a higher nominal instrument pressure (analog output can then be correspondingly matched)
- install a standard throttling device upstream from the SCPSD

## Error Messages

Display	Description
<b>Att</b>	The set value is lower than the other respective parameters. When Enter is activated, the smaller value is matched up.
<b>Err1</b>	System Error (Internal)
<b>Err2</b>	Nominal instrument pressure range was exceeded by 10%. Please check system pressure.
<b>Err3</b>	Nominal instrument pressure range has been exceeded Error in analog electronics. Please check system pressure.



**Dimensions**

**Cables (IP 67 Rated)**

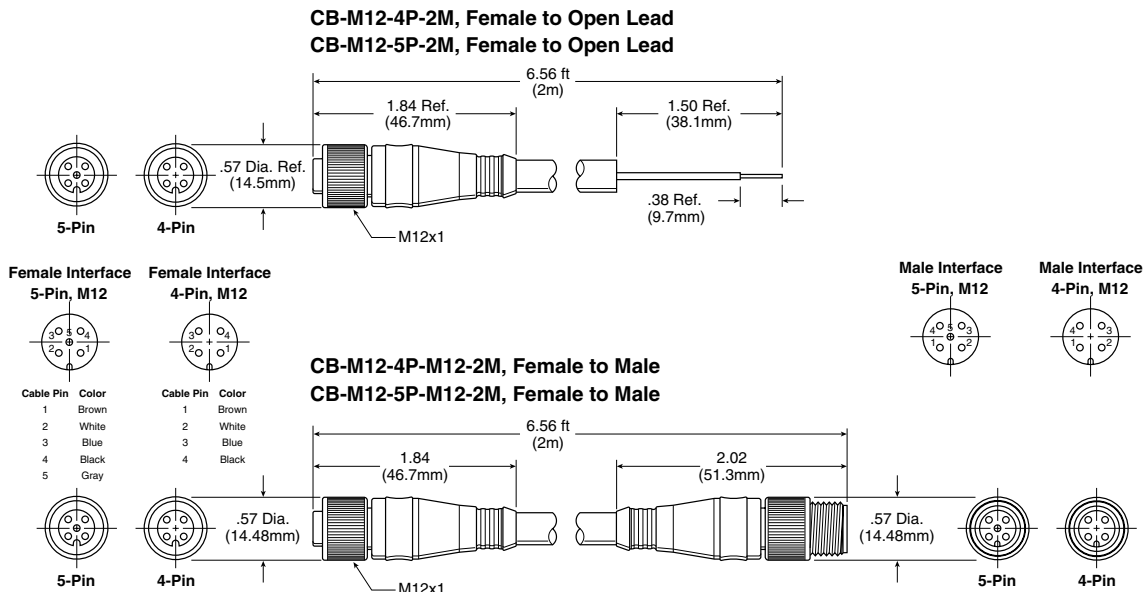

**Dimensions**

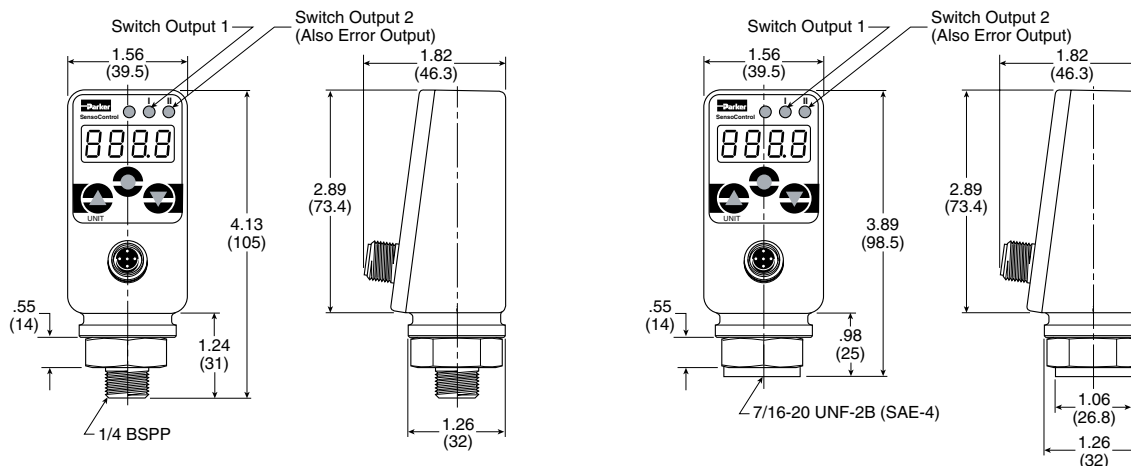

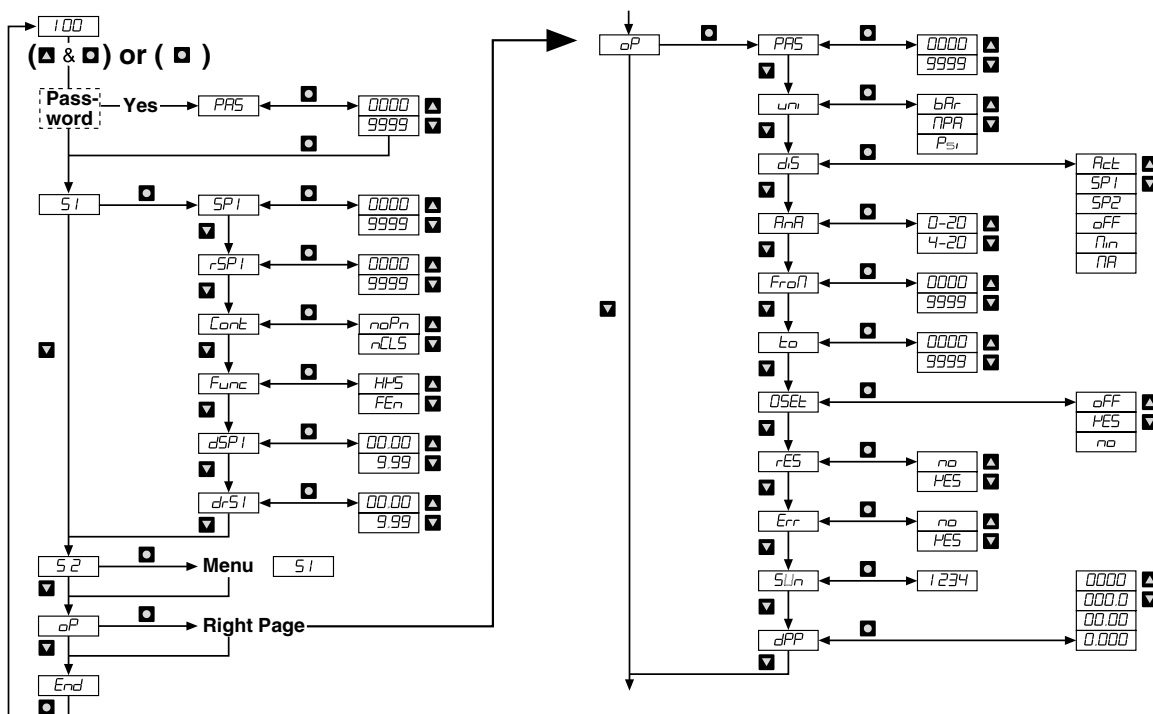

To Program Outputs and Options of SCPSD, press and hold the ▲ (Up Arrow Icon) then press the ● (Circle Icon) until Pro6 is displayed. Release all buttons and follow menu to program outputs and options.

To Review Programed Outputs and Options of SCPSD, press and hold the ● (Circle Icon) until Pro6 is displayed. Release the ▲ (Circle Icon) and follow menu to program option and status.

## Parameters Shown in Digital Display

To program switch outputs in menu **S1** (S1 = output 1) or **S2** (S2 = output 2), press ▲ and hold, then press ●. Pro6 will be displayed for 2 seconds.

**PRs** This is dedicated to a password. Entry into the programming mode can be secured only when the correct figures have been entered

Menu for programming the switch outputs:

**S1** S1 = Switch output 1

**S2** S2 = Switch output 2 (Menu is not active if S2 is being used as an error output)

Switching point (SP): upper limiting value / pressure, at which the switch output changes its status.

**SP1** SP1 = Switch output 1; input as pressure value (e.g. 400 bar)

**SP2** SP2 = Switch output 2; input as pressure value (e.g. 430 bar)

Reverse switching point (rSP): lower limiting value/pressure at which switch output changes its status.

**rSP1** rSP1 = Reverse switching point (rSP1) of switch output 1; input as pressure value (e.g. 390 bar)

**rSP2** rSP2 = Reverse switching point (rSP2) of switch output 2; input as pressure value (e.g. 420 bar)

The reverse switching point is always smaller than its respective switching point. If the reverse switching point is set higher than the switching point, the reverse switching point will be set automatically 0.5% of the instrument nominal pressure below the switching point. The warning sign **Att** (attention) will appear, which can be cleared with Enter. ●

**cont** Switch output as

**noPn** = closer

**nCLS** = opener

**Func** Selection of switching functions:

**HySt** = Hysteresis function

**FEn** = Window function

Delay times; input from 0 to 9.99 s.

**dSP1** dSP1 = delay time switching point output 1

**drSL** drSL = delay time reverse switching point output 1

**dSP2** dSP2 = delay time switching point output 2

**drS2** drS2 = delay time reverse switching point output 2



## Options Program (See Next Page)



## Settings for Options Program

**oP** Options program

**PA5** Password input

0000 = no password

Example password 1234 = 1234

**uni** Setting of units:

**bAr** = bar    **NPA**= MPa    **PSi**= PSI

**diS** Display: Value which will be shown on the digital display in run mode.

**Act** = Actual system pressure

**Nin** = Minimum system pressure; (pressure troughs)

**NA** = Maximum system pressure; (pressure peaks)

**SP1** = Switch point 1

**SP2** = Switch point 2

**OFF** = off indication

**AnA** Setting of analog output (see point 4)

**0-20** = 0-20 mA    **4-20** = 4-20 mA

**FroN** Calibration of starting value (0 or 4 mA) for the analog output. Settable from 0 to nominal instrument pressure.

Example for **AnA** = 4-20:

**0000** = at 0 bar the analog output yields 4 mA.

The starting value is always smaller than the end value. If the starting value is set greater than the end value, then the starting value will be automatically set 5% of the nominal instrument pressure below that of the end value. The warning sign **Att 1** will appear, which can be cleared with the Enter sign. 

**to** Calibration of end value (20mA) for the analog output.

Settable from 0 up to nominal instrument pressure.

**0010** = at 10 bar the analogue output yields 20 mA.

**0Set** Zero adjustment: The actual pressure will be stored as a new zero point. For safety reasons this is limited to the range  $\pm 5\%$  of the nominal instrument pressure. Application example: a system with a continuous residual pressure, but which should be displayed as 0 bar.

**OFF** = factory calibration

**YES** = undertake zeroing adjustment now

**no** = go back to the menu and do not make any new zeroing adjustments. After a zeroing adjustment, a pressure of up to 20 bar can be displayed as 0 on a 400 bar SCPSD. Before working on a system, it must be ensured that there is no pressure in it.



**rES** Clearing the minimum and maximum value memory

**YES** = yes, clear memory now

**no** = no, do not clear memory

**Err** Programming switch output 2 as an error output

**YES** = yes

**no** = no

Switch Output 2 can be used optionally as an error output to display pressure switch function errors. As an error output it is normally closed, and in case of errors (**Err 1**, **Err 2**, **Err 3**) it is open. At the same time LED II lights up. The display and the output remain active until the error is cleared.

**SUn** Indication of Software Version

**dPP** Setting of the decimal point. (The maximum number of decimal points depends on the nominal pressure of the SCPSD instrument)

**0000** = no decimal point

**000.0** = 1 decimal point

**00.00** = 2 decimal points

**0.000** = 3 decimal points

**End** End of programming mode



## Electrical Test Unit (M12, 5-Pin)

SCSN-450-PSD



## SCPSD Programming Kit

SCSD-PRG-KIT

Optical Interface Device that allows read / write and storing of SCPSD configuration data. Kit includes optical interface device, electrical test unit with PC cable (RS232 connector) and software.

