

CATALOGUE

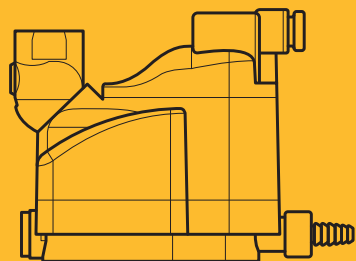

COMPRESSED AIR AND GAS TREATMENT CATALOGUE

Gas Separation and Filtration Division EMEA

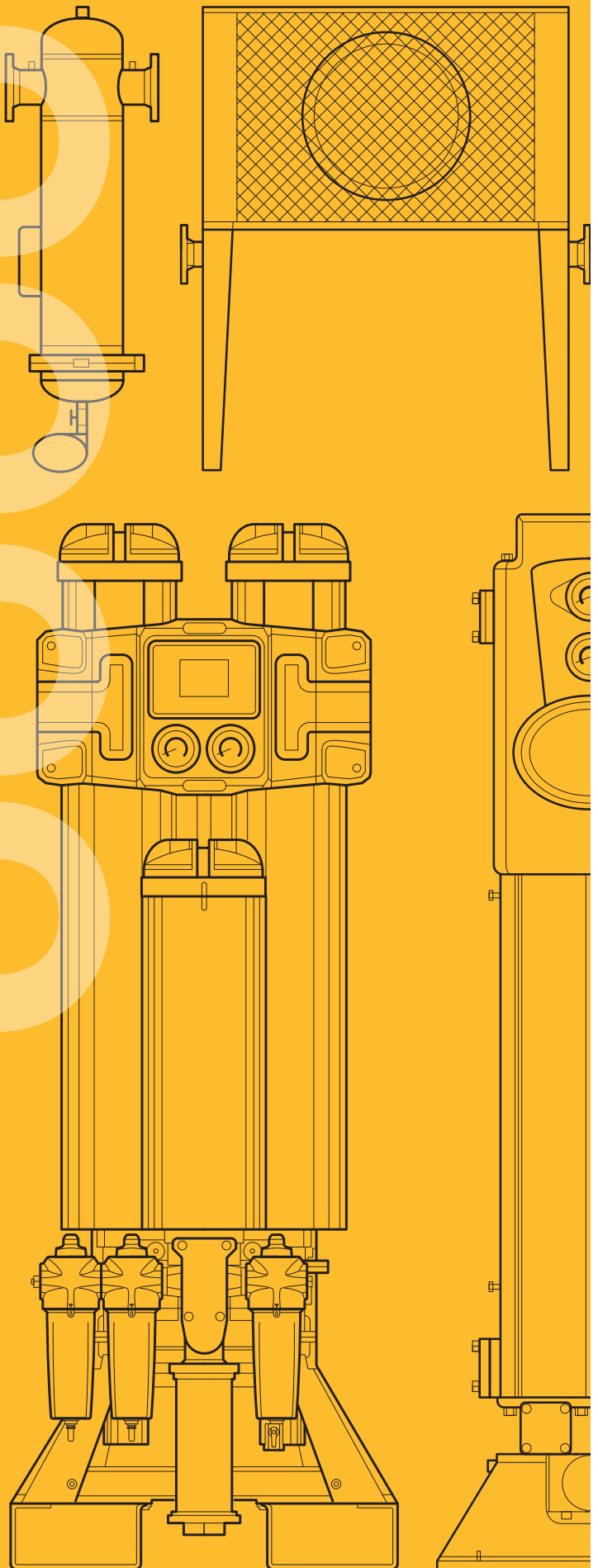

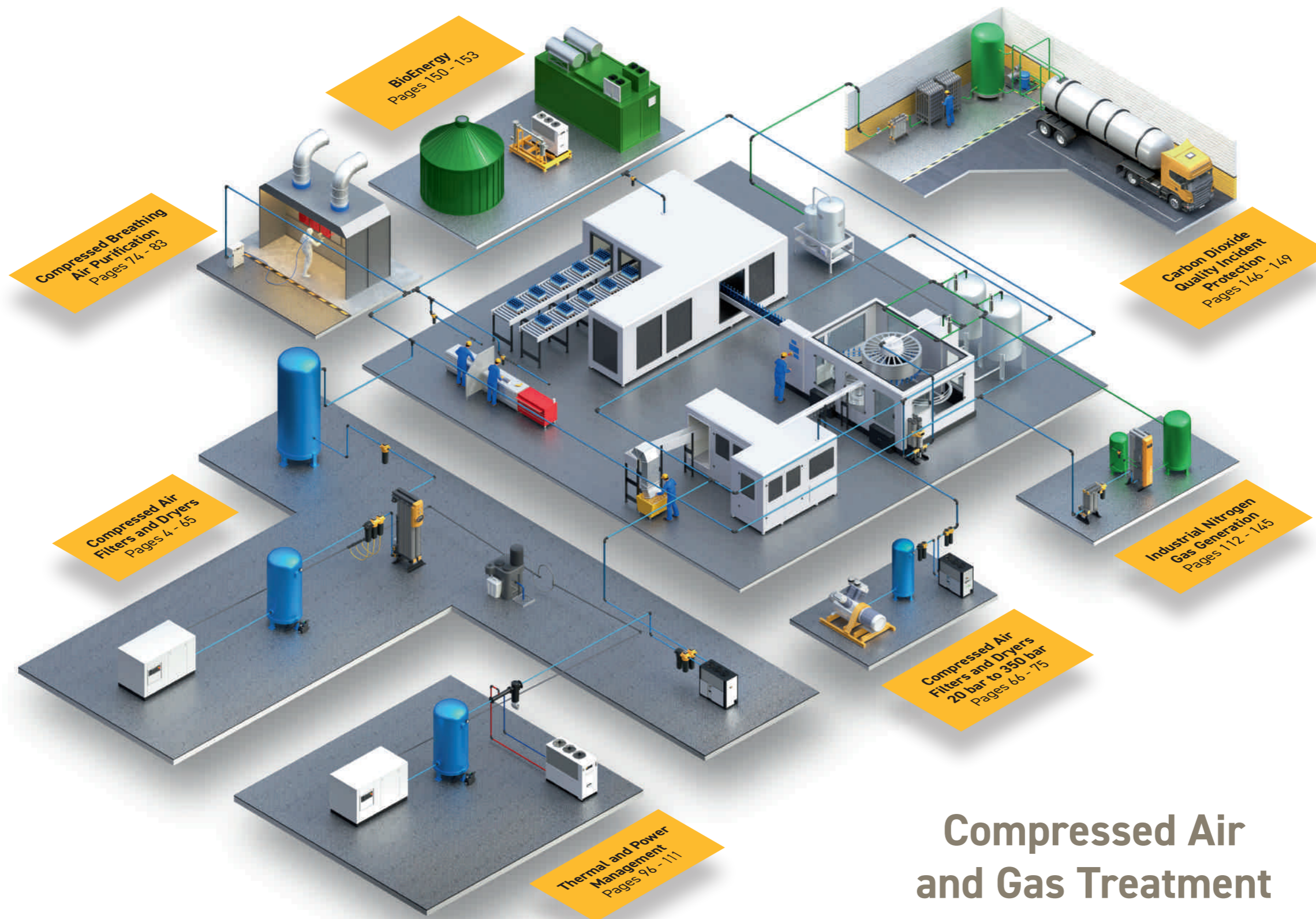

Compressed Air and Gas Treatment



Gas Separation and Filtration Division EMEA

Parker Gas Separation and Filtration EMEA offer a range of filtration and separation solutions that are designed to meet the needs of global customers through a dedicated focus on key market sectors.

Operating from manufacturing sites in the UK, Italy, the Netherlands and the Czech Republic, the division designs, develops, manufactures and markets compressed air/gas filters and dryers, process chillers and coolers, condensate management products, breathing air purifiers, nitrogen, hydrogen and zero air on-site gas generators for many diverse markets, industries and applications where compressed air and gas purity, product quality, technological excellence and global customer support are paramount.

Parker Gas Separation and Filtration EMEA products and systems deliver a unique combination of innovation and excellence in the most demanding applications, helping engineers to maximise the productivity and profitability of their manufacturing and process operations and with a focus on delivering real and lasting value to every customer.

For over 50 years, Parker GSFE have remained instrumental in the development of both the international standards for compressed air and filter testing, and continue to work closely on new standards with governing bodies such as the British Compressed Air Society (BCAS), the International Standards Organisation (ISO), PNEUROП, and the USA Compressed Air and Gas Institute (CAGI).

Parker GSFE's goal is to dominate our chosen markets, aiming to be the number one choice supplier of compressed air / gas treatment products and on-site gas generators.

Achieving this, by recruiting the best teams, and by passionately developing our people, technology and products to help us exceed our customers' expectations, bringing new products, services and solutions to the market. We believe in, and strive to maintain, close relationships with our customers, making us their global partner of choice for compressed air and gas treatment products and services.

GSFE Compressed Air and Gas Treatment Manufacturing Locations

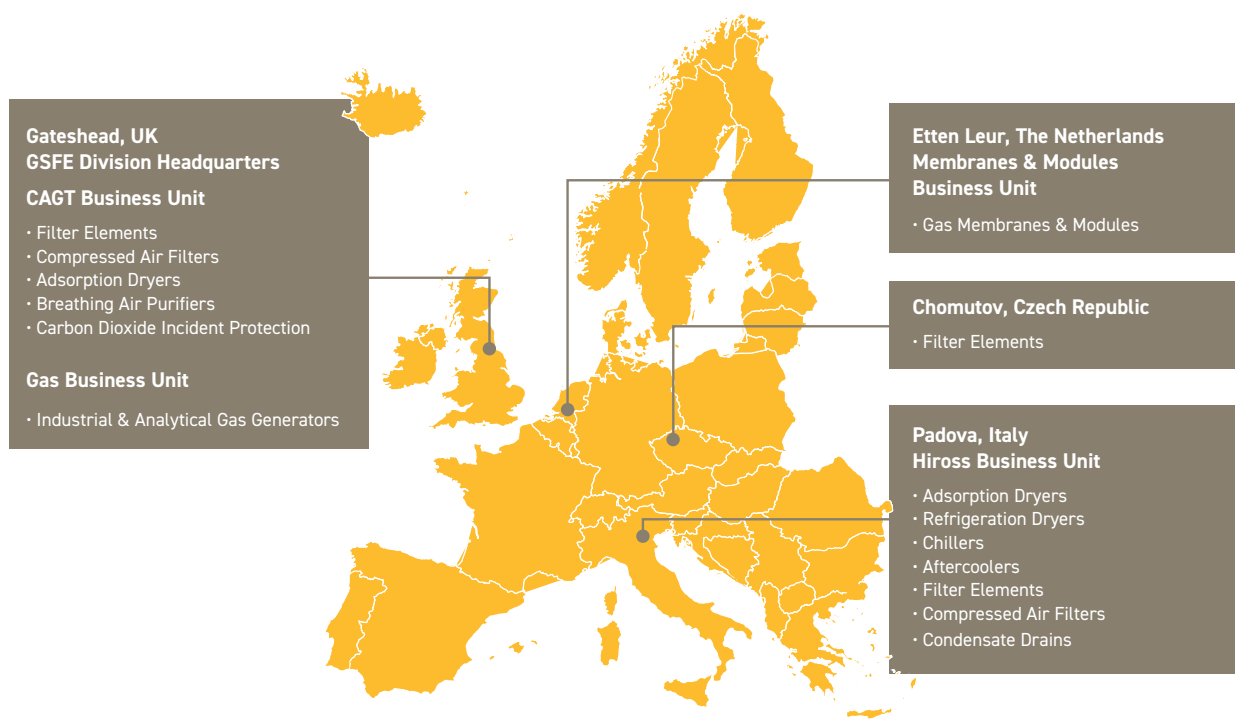

GSFE Compressed Air and Gas Treatment Technology Brands



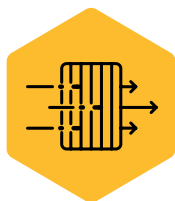

FILTRATION AND SEPARATION



ADSORPTION



REFRIGERATION AND COOLING

COMPRESSED AIR FILTERS

- ISO Compressed Air Quality Standards	4
- Product Application Information	6
- Product Selection Criteria	8
- OIL-X Liquid Separator	10
- SFH Liquid Separators (Carbon Steel)	12
- OIL-X Coalescing & Dry Particulate Filters	14
- OIL-X Coalescing, Dry Particulate & Oil Vapour Reduction Filters (Carbon Steel)	16
- OIL-X Point Of Use Oil Vapour Reduction Filter	18
- OIL-X OVR Plant Scale Oil Vapour Reduction	20
- OIL-X Combination Filter	22
- Hyperfilter Coalescing, Dry Particulate & Oil Vapour Reduction Filters	24
- OIL-X 0003G Micro Filter	26
- OIL-X Filter Accessories	27

COMPRESSED AIR DRYERS

Adsorption

- K-MT Small Flow Heatless	28
- KA-MT Small Flow Heatless	30
- CDAS Medium Flow Heatless	32
- OFAS Medium Flow Heatless	34
- FBP Medium Flow Heatless	36
- CDAS HL ATEX Medium Flow Heatless	38
- MX Large Flow Heatless	40
- MX ATEX Pneumatic Heatless	42
- Flow Control Device - MX Multibank	44
- MX Heatless Dryers (FAQs)	49
- KE-MT Large Flow Heatless	50
- MXLE Large Flow Heatless Low Energy	52
- WVM Large Flow Vacuum Low Energy	54

Hybrid

- ATT Low Energy	58
------------------	----

Refrigeration

- SPE Direct Expansion	60
- PST Direct Expansion	62
- PST Twin Direct Expansion	64

COMPRESSED AIR FILTERS AND DRYERS (20 BAR TO 350 BAR)

- IP50 - 50 Bar Compressed Air Filter	66
- SPH - 50 Bar Refrigeration Dryer	68
- PSH - 50 Bar Refrigeration Dryer	70
- GH - 350 Bar Compressed Air Filter	72
- HDK-MT - 350 Bar Compressed Air Dryer	74

COMPRESSED BREATHING AIR PURIFICATION

- BAC-4015	76
- BA-DME 012-080	78
- Breathing Star BSP-MT 1-8	80
- Breathing Star BSP-MT 10-95	82
- BAM 10-70	84

CONDENSATE MANAGEMENT

Oil/Water Separators

- ES2000 Series - Product Selection	86
- ES2000 Series	90
- ES2000 Series Maintenance Kits	91

Compressed Air Drains

- HDF & ED Level Sensing	92
--------------------------	----

THERMAL AND POWER MANAGEMENT

Aftercoolers

- Hypercool Air Cooled	96
- Hypercool Water Cooled	95

Production Process Water Chillers

- Hyperchill Plus	96
- Hyperchill Plus (50Hz) - Selection Information	98
- Hyperchill Plus (60Hz UL) - Selection Information	101
- Hyperchill Plus - Kits and Accessories	103
- Hyperchill	104
- Hyperchill (50Hz) - Selection Information	104
- Hyperchill (60Hz UL) - Selection Information	109
- Hyperchill Laser	110

INDUSTRIAL NITROGEN GAS GENERATORS

Pressure Swing Adsorption

- Product Application Information	112
- NITROSource	116
- NITROSource Compact	118

Membrane Modules

- SmartFluxx SA604	120
- SmartFluxx SA708	121
- SmartFluxx SA1508	122
- SmartFluxx SA1508SS	123
- SmartFluxx SA15020	124
- HiFluxx ST304	125
- HiFluxx DT304	126
- HiFluxx TT304	127
- HiFluxx ST504	128
- HiFluxx ST604	129
- HiFluxx DT604	130
- HiFluxx TT604	131
- HiFluxx ST606	132
- HiFluxx TT606	133
- HiFluxx ST608	134
- HiFluxx ST704	135
- HiFluxx ST708	136
- HiFluxx ST6010	137
- HiFluxx ST1506	138
- HiFluxx DT1506-8	139
- HiFluxx ST1508	140
- HiFluxx DT1508	141
- HiFluxx DT1508SS	142
- HiFluxx ST15020-1	143
- HiFluxx ST1508SS	144
- HiFluxx Temperature Correction Factors	145

CARBON DIOXIDE QUALITY INCIDENT PROTECTION

- Product Application Information	146
- PCO2 Quality Incident Protection Systems	148

BIOENERGY

- Biogas Dehumidification Systems	150
- Hyperfilter BioEnergy	152
- Hypercool BioEnergy	153
- Hypersep BioEnergy	153
- Hyperdrain BioEnergy	153

REPLACEMENT FILTER ELEMENTS AND MAINTENANCE KITS FOR LEGACY PRODUCTS

Parker domnick hunter

- OIL-X EVOLUTION / OIL-Xplus Advantage	154
- PCO2 MK1	155
- SE and ES Oil / Water Separator	155

Parker Zander

- G / GL / GL Plus / LV	156
-------------------------	-----

Parker Worldwide Contacts	158
---------------------------	-----

CONTENTS

Specifying air quality (purity) in accordance with ISO8573-1:2010, the international standard for compressed air quality

ISO8573-1 is the primary document used from the ISO8573 series as it is this document which specifies the amount of contamination allowed in each cubic metre of compressed air.

ISO8573-1 lists the main contaminants as solid particulate, water and oil. The purity levels for each contaminant are shown separately in tabular form, however for ease of use, here all three contaminants are combined into one easy to use table.

ISO8573-1:2010 CLASS	Solid Particulate			Mass Concentration mg/m ³	Water		Oil Total Oil (aerosol, liquid and vapour) mg/m ³
	Maximum number of particulates per m ³				Vapour Pressure Dewpoint	Liquid g/m ³	
	0.1 - 0.5 micron	0.5 - 1 micron	1 - 5 micron				
0	As specified by the equipment user or supplier and more stringent than Class 1						
1	≤ 20,000	≤ 400	≤ 10	-	≤ -70°C	-	0.01
2	≤ 400,000	≤ 6,000	≤ 100	-	≤ -40°C	-	0.1
3	-	≤ 90,000	≤ 1,000	-	≤ -20°C	-	1
4	-	-	≤ 10,000	-	≤ +3°C	-	5
5	-	-	≤ 100,000	-	≤ +7°C	-	-
6	-	-	-	≤ 5	≤ +10°C	-	-
7	-	-	-	5 - 10	-	≤ 0.5	-
8	-	-	-	-	-	0.5 - 5	-
9	-	-	-	-	-	5 - 10	-
X	-	-	-	> 10	-	> 10	> 10

Specifying air purity in accordance with ISO8573-1:2010

When specifying the purity of air required, the standard must always be referenced, followed by the purity class selected for each contaminant (a different purity class can be selected for each contaminant if required).

An example of how to write an air quality specification is shown below:

ISO8573-1:2010 Class 1:2:1

ISO8573-1:2010 refers to the standard document and its revision, the three digits refer to the purity classifications selected for solid particulate, water and total oil. Selecting a air purity class of 1:2:1 would specify the following air quality when operating at the standard's reference conditions:

Class 1 Particulate

In each cubic metre of compressed air, the particulate count should not exceed 20,000 particles in the 0.1 - 0.5 micron size range, 400 particles in the 0.5 - 1 micron size range and 10 particles in the 1 - 5 micron size range.

Class 2 Water

A pressure dewpoint (PDP) of -40°C or better is required and no liquid water is allowed.

Class 1 Oil

In each cubic metre of compressed air, not more than 0.01mg of oil is allowed. This is a total level for liquid oil, oil aerosol and oil vapour.

ISO8573-1:2010 Class 0

- Class 0 does not mean zero contamination
- Class 0 does not mean oil-free compressed air
- A Class 0 compressor does not guarantee oil-free compressed air
- Class 0 does not solely refer to oil contamination
- A Class 0 specification must be 'cleaner' than the Class 1 specification for the contaminant chosen
- The contamination levels stated for a Class 0 specification must also be within the measurement capabilities of the test equipment and test methods shown in ISO8573 Pt 2 to Pt 9
- The Class 0 specification must clearly state which contaminant the Class 0 claim refers to i.e. "Solid Particulate", "Water" or "Total Oil (aerosol, liquid & vapour)"
- Class 0 requires the user or the equipment supplier to show a contamination level as part of a written specification
- **Example of a correctly written Class 0 specification**
"When preceded by OIL-X Grade AO General Purpose & Grade AA High Efficiency Coalescing Filters, OIL-X OVR Grade Adsorption Filters provide a delivered air quality in accordance with ISO8573-1:2010 Class 0 (≤0.003 mg/m³) for total oil (oil aerosol & oil vapour)"
- The agreed Class 0 specification must be written on all documentation to be in accordance with the standard
- Stating Class 0 without an accompanying contaminant specification is meaningless and not in accordance with the standard

Selecting Parker purification equipment to comply with ISO8573-1:2010 air quality standard

Simple guidelines for the selection of purification equipment

1. Purification equipment is installed to provide air quality, therefore you must first of all identify the quality of compressed air required for the compressed air leaving the compressor room and for each point of use on the compressed air system.
2. The air quality required at each point of use may differ dependent upon the application.
3. Using the quality classifications shown in ISO8573-1 will allow easy selection of purification equipment.
4. ISO8573-1:2010 is the latest edition of the standard, however some facilities may still be operating on older revisions.
5. Specifying air quality as ISO8573-1, ISO8573-1:1991 or ISO8573-1:2001 refers to the previous editions of the standard and may result in a different quality of delivered compressed air.
6. Ensure any ISO8573-1 air purity classifications are written in full and include the revision year to allow for correct product selection.
7. Remember - Oil-free compressor installations require the same filtration considerations as oil lubricated compressor installations.

ISO8573-1:2010 CLASS	Solid Particulate		Water	Oil
	Wet Particulate	Dry Particulate	Vapour	Total Oil (aerosol, liquid and vapour)
0	-	-	-	OIL-X Grade AO + AA + OVR
1	OIL-X Grade AO + AA	OIL-X Grade AO (M) + AA (M)	Dryer sized for -70°C PDP	OIL-X Grade AO + AA + OVR OIL-X Grade AO + AA + ACS
2	OIL-X Grade AO	OIL-X Grade AO (M)	Dryer sized for -40°C PDP	OIL-X Grade AO + AA
3	OIL-X Grade AO	OIL-X Grade AO (M)	Dryer sized for -20°C PDP	OIL-X Grade AO
4	OIL-X Grade AO	OIL-X Grade AO (M)	Dryer sized for +3°C PDP	OIL-X Grade AO
5	OIL-X Grade AO	OIL-X Grade AO (M)	Dryer sized for +7°C PDP	-
6	-	-	Dryer sized for +10°C PDP	-

For further information relating to ISO Compressed Air Quality Standards please refer to our white paper 'Introduction to ISO Compressed Air Quality Standards'. Available at parker.com/gsf

Cost effective system design

To achieve the stringent air quality levels required for today's modern production facilities, a careful approach to system design, commissioning and operation must be employed.

Treatment at one point alone is not enough and it is highly recommended that the compressed air is treated in the compressor room to a level that will provide general purpose air to the site and also protect the distribution piping. Point of use purification should also be employed, not only to remove

any contamination remaining in the distribution system, but also with specific attention on the quality of air required by each application. This approach to system design ensures that air is not 'over treated' and provides the most cost effective solution to high quality compressed air.

FOOD / BEVERAGE / PHARMACEUTICAL - DIRECT CONTACT APPLICATIONS

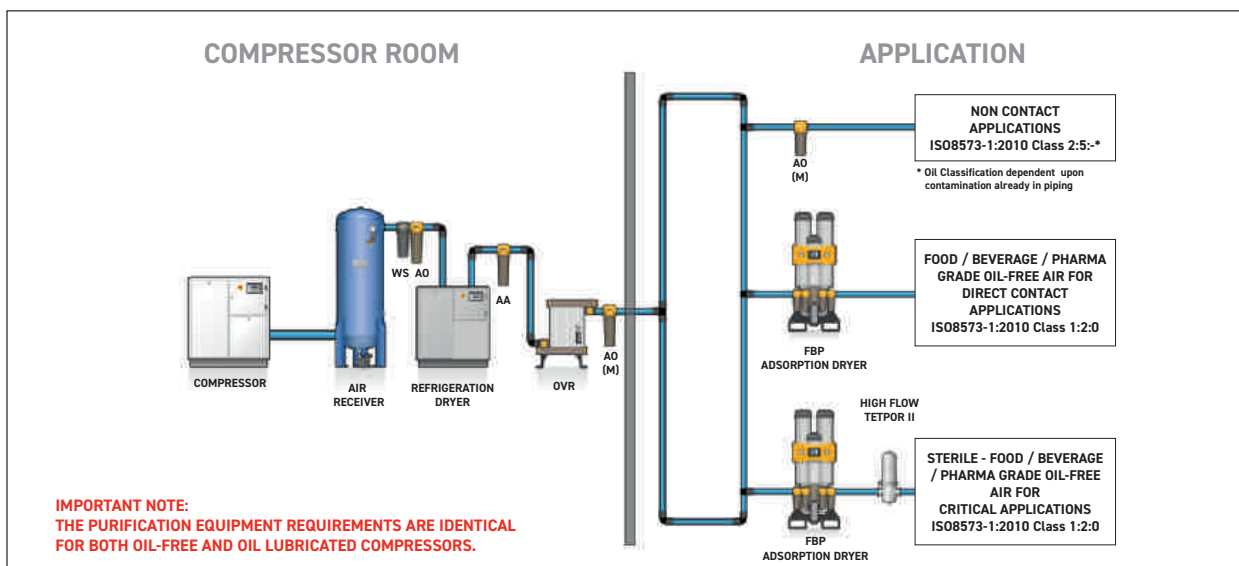
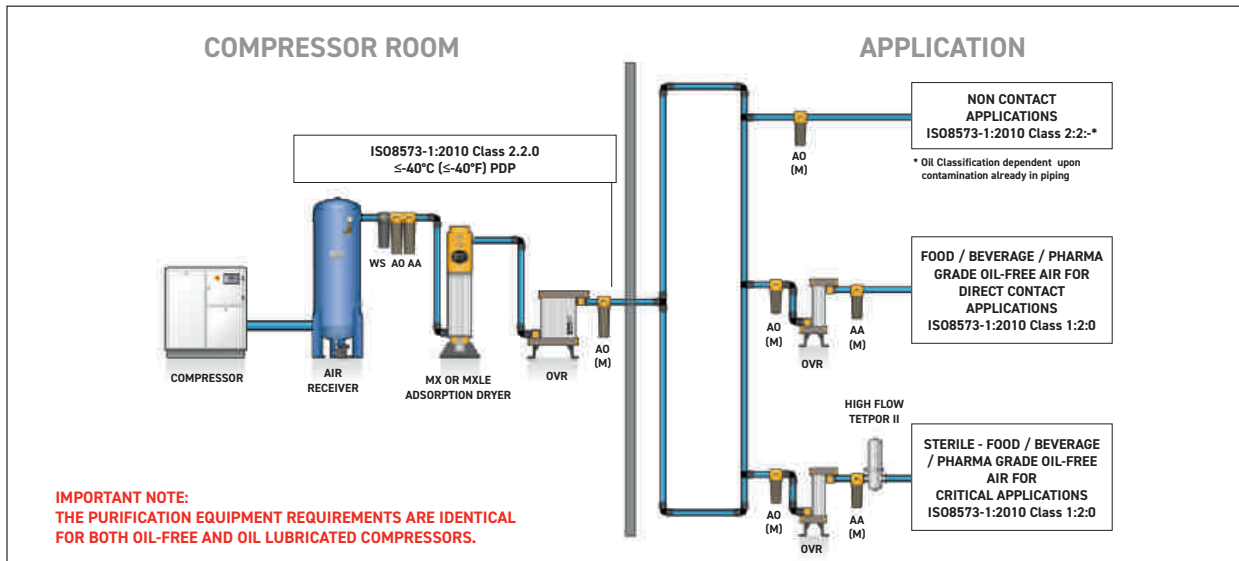

Typical Applications

Direct contact / in-direct contact applications in food manufacturing / beverage bottling / pharmaceutical manufacturing / dairies / breweries / wineries / distilleries (In accordance with BCAS Best Practice Guideline 102 Food & Beverage Grade Compressed Air).

HIGH QUALITY TECHNICALLY OIL-FREE AIR

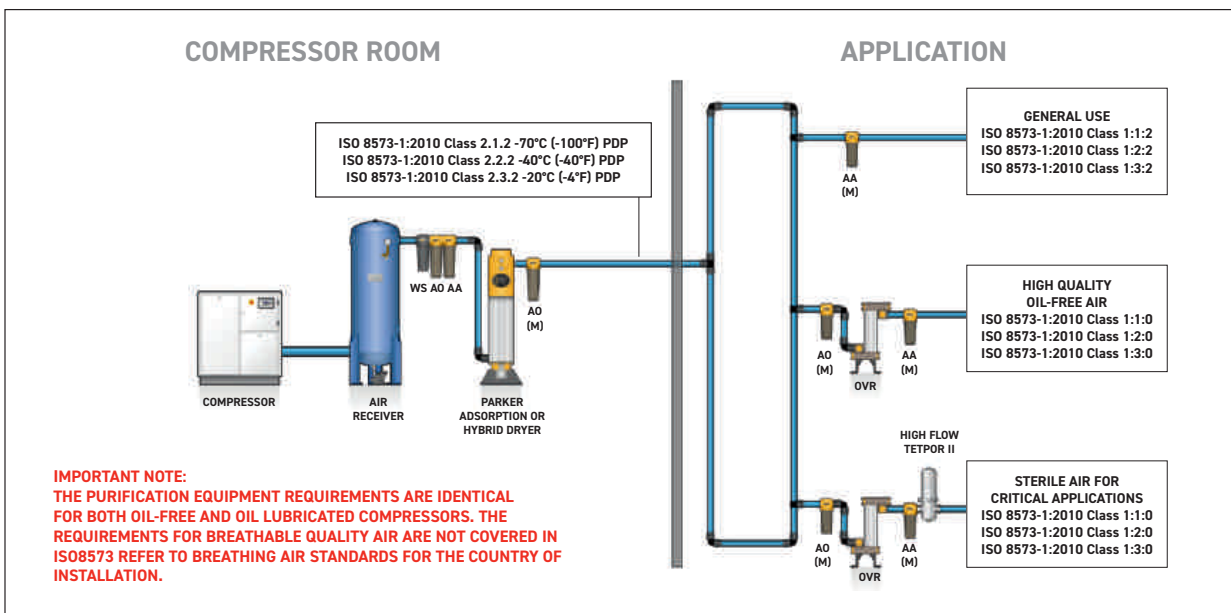

Typical Oil-Free Air Applications

Blow Moulding of Plastics e.g. P.E.T. Bottles
 Electronics Manufacturing
 CDA systems for electronics manufacturing
 Film processing
 Critical instrumentation
 Advanced pneumatics
 Air blast circuit breakers

Decompression chambers
 Cosmetic production
 Medical air
 Dental air
 Lasers and optics
 Robotics
 Spray painting

Air bearings
 Pipeline purging
 Measuring equipment
 Blanketing
 Modified Atmosphere Packaging
 Pre-treatment for on-site gas generation

GENERAL PURPOSE AIR WITH OIL-FREE AIR FOR CRITICAL APPLICATIONS

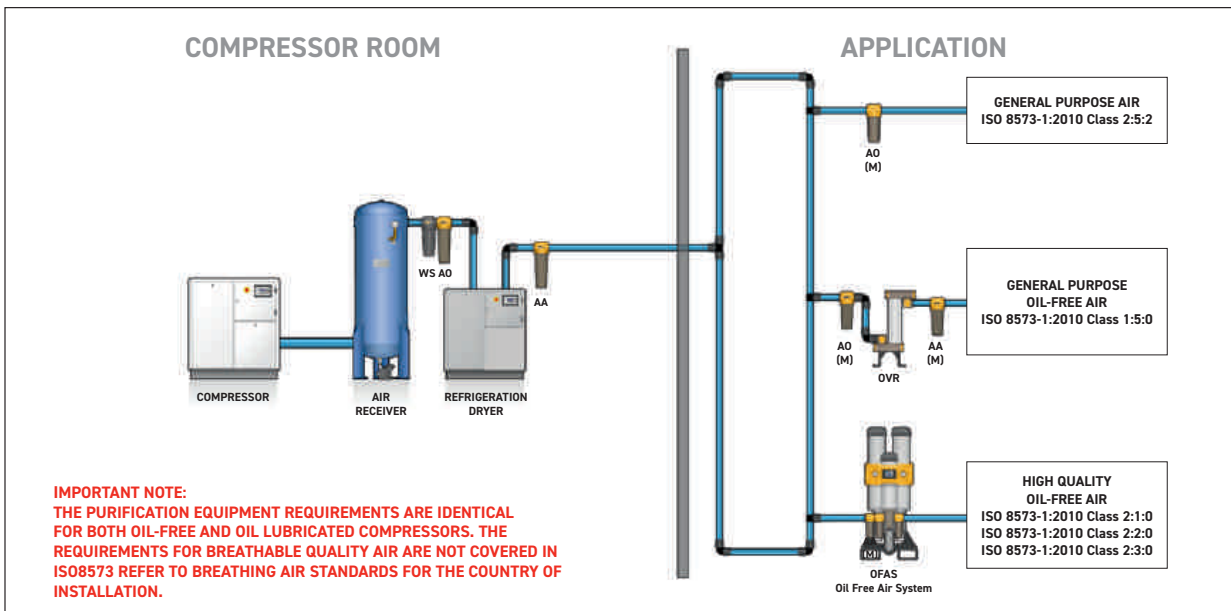

Typical General Purpose Applications

General ring main protection
 Pre-filtration to point of use adsorption air dryers
 Plant automation
 Air logistics
 Pneumatic tools
 General instrumentation
 Metal stamping

Forging
 General industrial assembly (no external piping)
 Air conveying (non food)
 Air motors
 Workshop (tools)
 Garage (tyre filling)

Temperature control systems
 Blow guns
 Gauging equipment
 Raw material mixing
 Sand / bead blasting

Selecting the right purification products for your compressed air system

To achieve the degree of air quality specified by ISO8573-1, a careful approach to system design, commissioning and operation must be adopted.

Parker recommends that compressed air is treated:

- **Prior to entry into the distribution system**
- **At critical usage points and applications**

This ensures that contamination already in the distribution system is removed.

Purification equipment should be installed where the air is at the lowest possible temperature (i.e. downstream of after-coolers and air receivers). Point-of-use purification equipment should be installed as close as possible to the application.

In order to correctly size purification equipment, there are a number of primary operating parameters that must be obtained from the users site. These are:

- **The MAXIMUM compressed air flow rate into the filters / dryer**
- **The MINIMUM operating pressure into the filters / dryer**
- **The MAXIMUM operating temperature into the filters / dryer**
- **The MAXIMUM ambient air temperature where the equipment is to be installed**
- **The required dewpoint (dryers)**

Individually, each of the primary operating parameters can influence product sizing however collectively they can have a major impact on product sizing and performance.

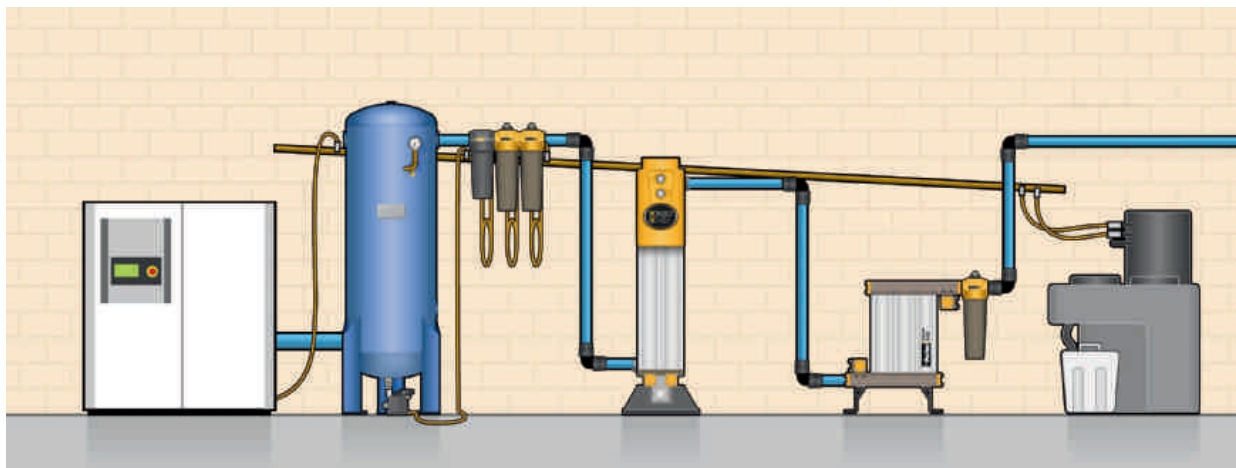

With the primary operating parameters, basic product selections can be made, however additional information may also be required to finalise product selection. Secondary parameters include:

- **Minimum operating temperature**
- **Preferred pipe connections**
- **Available electrical supply (voltage / phase / frequency)**
- **Customers preference regarding drains, controllers or other options**

Why is MAXIMUM Flow Rate Important?

Filtration: As compressed air flow rates increase, contamination levels increase and a larger filtration surface area is required to ensure adequate filtration performance, low pressure drop and 12 month lifetime of filter elements.

Dryers: As compressed air flow rates increase, the amount of water vapour the dryer must remove also increases.

Adsorption dryers must be sized on the highest flow rate to ensure the desiccant bed is large enough to provide the correct contact time and dewpoint.

Refrigeration dryers must be sized to ensure the heat exchanger is large enough and has enough cooling capacity.

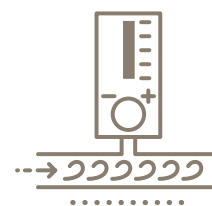

Why is MINIMUM Inlet Pressure Important?

Dryers: As pressure decreases, the volume of compressed air increases, as does the water vapour content, therefore the amount of water vapour the dryer must remove also increases. Dryers must be sized for minimum inlet pressure to account for the increased amount of water vapour present.



Why is MAXIMUM Inlet Temperature Important?

Dryers: As the temperature of the compressed air increases, so does the water vapour content, therefore the amount of water vapour the dryer must remove also increases. Dryers must be sized for maximum inlet temperature to account for the increased amount of water vapour present.

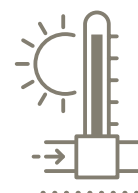

Why is MAXIMUM Ambient Temperature Important?

Refrigeration & Tandem Technology Dryers: Air cooled refrigeration & Tandem Technology dryers use ambient air for heat exchange.

The lower the ambient air temperature, the better the heat exchange process

Poor ventilation and / or high ambient air temperatures will result in loss of dewpoint.

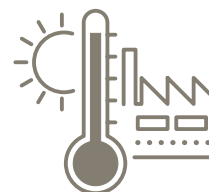

Why Correct a Dryer for Dewpoint?

Adsorption Dryers: Dewpoint is derived from contact time between the air and the desiccant material, lower dewpoint's typically require the dryer to be de-rated to provide more contact time.

Refrigeration Dryers: The size of the heat exchangers affects the cooling capacity, too little cooling capacity results in poor dewpoint.

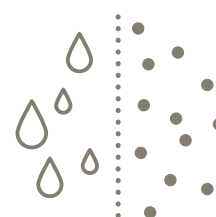

Frequently Asked Questions: High / Low Temperatures

High Temperatures

Maximum temperature (inlet & ambient) for dryers is 50°C or 122°F. For temperatures above this it is more cost effective to install an after-cooler than oversize a dryer. Also as a dryer increases in size, so does the volume of purge required to regenerate the dryer. Fitting an after-cooler is also more cost effective in terms of energy consumption.

Low Temperatures

Freezing water causes damage to a dryer therefore as the temperature approaches freezing, the dryer and ancillaries need protection. Sub-zero temperatures also affect the function of seals and electronics.

- Always keep purification equipment under shelter and out of cold wind / direct air blasts
- Trace heat & insulate anywhere where moisture is present i.e. Inlet filtration / drain lines / Inlet valves / columns / exhaust valves

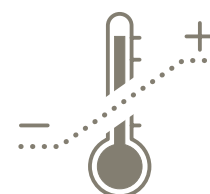

OIL-X Liquid Separators

Separation Performance

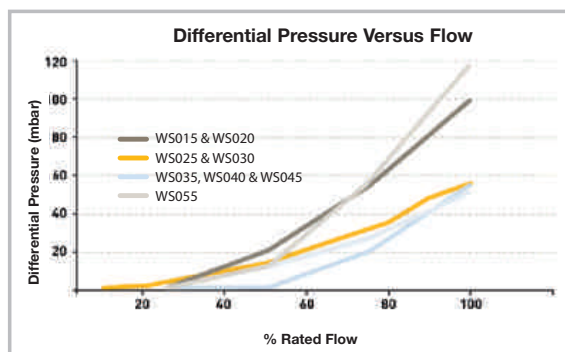
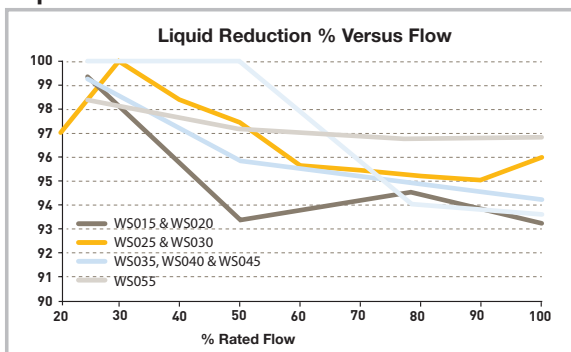

Technical Data

Filtration Grade	Water Separator Models	Minimum Operating Pressure		Maximum Operating Pressure		Minimum Operating Temperature		Maximum Operating Temperature	
		bar g	psi g	bar g	psi g	°C	°F	°C	°F
WS	P010A <input type="checkbox"/> FX - P055J <input type="checkbox"/> FX	1	15	16	232	2	35	80	176
	P060K <input type="checkbox"/> FX	1	15	16	232	2	35	66	150

Flow Rates

Model	Pipe Size	L/S	m ³ /min	m ³ /hr	cfm
WSP010A <input type="checkbox"/> FX	¼"	10	0.6	36	21
WSP010B <input type="checkbox"/> FX	⅜"	10	0.6	36	21
WSP010C <input type="checkbox"/> FX	½"	10	0.6	36	21
WSP015C <input type="checkbox"/> FX	½"	40	2.4	144	85
WSP020D <input type="checkbox"/> FX	¾"	40	2.4	144	85
WSP025D <input type="checkbox"/> FX	¾"	110	6.6	396	233
WSP025E <input type="checkbox"/> FX	1"	110	6.6	396	233
WSP030G <input type="checkbox"/> FX	1½"	110	6.6	396	233
WSP035G <input type="checkbox"/> FX	1½"	350	21	1260	742
WSP040H <input type="checkbox"/> FX	2"	350	21	1260	742
WSP045I <input type="checkbox"/> FX	2½"	350	21	1260	742
WSP050I <input type="checkbox"/> FX	2½"	800	48	2880	1695
WSP055J <input type="checkbox"/> FX	3"	800	48	2880	1695
WSP060K <input type="checkbox"/> FX	4"	1000	60	3600	2119

Separator Coding Example

Grade	Model	Pipe Size	Thread	Drain Option	Incident Monitor Option
WS	P & 3 digit code denotes filter housing size	Letter denotes pipe size	G = BSPP N = NPT	F = Float	I = Indicator X = None
WS	P010	A	G	F	X

Stated flows are for operation at 7 bar (g) (102 psi g) with reference to 20°C, 1 bar (a), 0% relative water vapour pressure. For flows at other pressures, apply the correction factors shown below.

Product Selection & Correction Factors

To correctly select a separator model, the flow rate of the separator must be adjusted for the minimum operating (inlet) pressure at the point of installation.

1. Obtain the minimum operating (inlet) pressure and maximum compressed air flow rate at the inlet of the filter.
2. Select the correction factor for minimum inlet pressure from the CFMIP table (always round down e.g. for 5.3 bar, use 5 bar correction factor)
3. Calculate the minimum filtration capacity. Minimum Filtration Capacity = Compressed Air Flow Rate x CFMIP
4. Using the minimum filtration capacity, select a filter model from the flow rate tables above (filter selected must have a flow rate equal to or greater than the minimum filtration capacity).

CFMIP - Correction Factor Minimum Inlet Pressure

Minimum Inlet Pressure	bar g	1	2	3	4	5	6	7	8	9	10	11	12	13	14	15	16
	psi g	15	29	44	58	73	87	100	116	131	145	160	174	189	203	218	232
Correction Factor		4.00	2.63	2.00	1.59	1.33	1.14	1.00	0.94	0.89	0.85	0.82	0.79	0.76	0.73	0.71	0.68

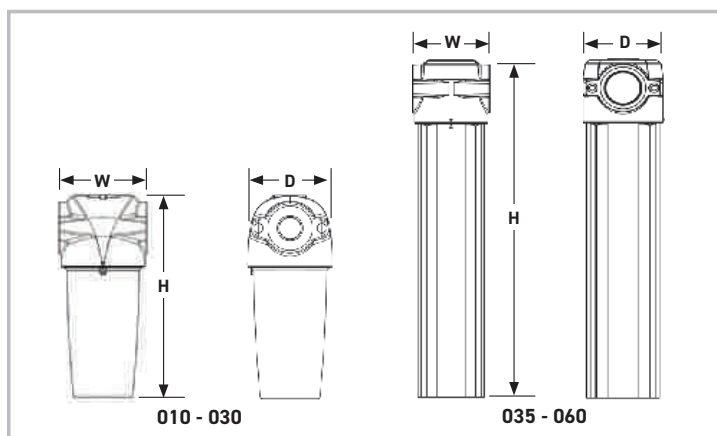

Weights & Dimensions

Model	Height (H)		Width (W)		Depth (D)		Weight	
	mm	ins	mm	ins	mm	ins	kg	lbs
010A	180	7.09	76	2.99	65	2.56	0.80	1.76
010B	180	7.09	76	2.99	65	2.56	0.79	1.75
010C	180	7.09	76	2.99	65	2.56	0.78	1.72
015C	238	9.37	89	3.5	84	3.31	1.08	2.39
020D	238	9.37	89	3.5	84	3.31	1.35	2.98
025D	277	10.9	120	4.72	115	4.53	2.64	5.83
025E	277	10.9	120	4.72	115	4.53	2.64	5.83
030G	367	14.45	120	4.72	115	4.53	2.54	5.61
035G	440	17.32	164	6.46	157	6.18	6.69	14.74
040H	440	17.32	164	6.46	157	6.18	6.46	14.23
045I	440	17.32	164	6.46	157	6.18	6.28	13.85
050I	516	20.31	192	7.56	183	7.20	10.80	23.81
055J	516	20.31	192	7.56	183	7.20	10.83	23.89
060K	847	33.3	420	16.54	282	11.10	10.83	23.89

Parker Catalogue Numbers (BSPP Models)

Model	Catalogue Number Water Separator
010A	WSP010AGFX
010B	WSP010BGFX
010C	WSP010CGFX
015C	WSP015CGFX
020D	WSP020DGFX
025D	WSP025DGFX
025E	WSP025EGFX
030G	WSP030GGFX
035G	WSP035GGFX
040H	WSP040HGFX
045I	WSP045IGFX
050I	WSP050IGFX
055J	WSP055JGFX
060K	WSP060KGFX

SFH Liquid Separators (Carbon Steel)

Technical Data

Filtration Grade	Water Separator Models	Minimum Operating Pressure		Maximum Operating Pressure		Minimum Operating Temperature		Maximum Operating Temperature	
		bar g	psi g	bar g	psi g	°C	°F	°C	°F
SFH	SFH029N - SFH209N	1	15	16	232	2	35	60	140

Flow Rates

Model	Pipe Size		L/S	m³/min	m³/hr	cfm
	Inlet	Outlet				
SFH029	DN80	DN80	490	29.4	1764	1038
SFH030	DN100	DN80	500	30.0	1800	1059
SFH037	DN100	DN100	610	36.6	2196	1293
SFH038	DN125	DN100	633	38.0	2280	1342
SFH066	DN125	DN125	1093	65.6	3936	2317
SFH067	DN150	DN125	1117	67.0	4020	2366
SFH088	DN150	DN150	1473	88.4	5304	3122
SFH089	DN200	DN150	1483	89.0	5340	3143
SFH097	DN200	DN200	1618	97.1	5826	3429
SFH142	DN250	DN200	2365	141.9	8514	5011
SFH180	DN300	DN200	2992	179.5	10770	6339
SFH209	DN350	DN200	3485	209.1	12546	7385

Separator Coding Example

Example code
SFH067N

Stated flows are for operation at 7 bar (g) (102 psi g) with reference to 20°C, 1 bar (a), 0% relative water vapour pressure. For flows at other pressures, apply the correction factors shown below.

Product Selection & Correction Factors

To correctly select a separator model, the flow rate of the separator must be adjusted for the minimum operating (inlet) pressure at the point of installation.

1. Obtain the minimum operating (inlet) pressure and maximum compressed air flow rate at the inlet of the filter.
2. Select the correction factor for minimum inlet pressure from the CFMIP table (always round down e.g. for 5.3 bar, use 5 bar correction factor)
3. Calculate the minimum filtration capacity. Minimum Filtration Capacity = Compressed Air Flow Rate x CFMIP
4. Using the minimum filtration capacity, select a filter model from the flow rate tables above (filter selected must have a flow rate equal to or greater than the minimum filtration capacity).

CFMIP - Correction Factor Minimum Inlet Pressure

Minimum Inlet Pressure	bar g	1	2	3	4	5	6	7	8	9	10	11	12	13	14	15	16
	psi g	15	29	44	58	73	87	100	116	131	145	160	174	189	203	218	232
Correction Factor		4.00	2.63	2.00	1.59	1.33	1.14	1.00	0.94	0.89	0.85	0.82	0.79	0.76	0.73	0.71	0.68

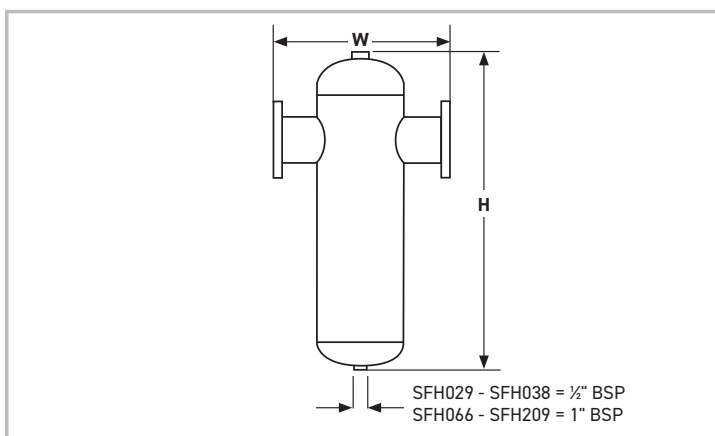

Weights & Dimensions

Model	Height (H)		Width (W)		Depth (D)		Weight	
	mm	ins	mm	ins	mm	ins	kg	lbs
SFH029	720	28.3	400	15.7	200	7.9	28	62
SFH030	720	28.3	400	15.7	200	7.9	29	64
SFH037	880	34.6	460	18.1	230	9.1	48	106
SFH038	880	34.6	460	18.1	230	9.1	49	108
SFH066	980	38.6	550	21.7	260	10.2	55	121
SFH067	980	38.6	550	21.7	260	10.2	56	123
SFH088	1060	41.7	570	22.4	290	11.4	82	180
SFH089	1060	41.7	570	22.4	290	11.4	85	187
SFH097	1160	45.7	660	26.0	320	12.6	126	277
SFH142	1255	49.4	680	26.8	351	13.8	148	326
SFH180	1455	57.3	750	29.5	390	15.4	160	352
SFH209	1655	65.2	830	32.7	430	16.9	205	451

Parker Catalogue Numbers

Model	Catalogue Number Water Separator
SFH029	SFH029N
SFH030	SFH030N
SFH037	SFH037N
SFH038	SFH038N
SFH066	SFH066N
SFH067	SFH067N
SFH088	SFH088N
SFH089	SFH089N
SFH097	SFH097N
SFH142	SFH142N
SFH180	SFH180N
SFH209	SFH209N

OIL-X Coalescing & Dry Particulate Filters

Filtration Performance

Filtration Grade	Filter Type	Particle Reduction (inc water & oil aerosols)	Max. Remaining Oil Content at 21°C (70°F)	Filtration Efficiency	Initial Dry Differential Pressure	Initial Saturated Differential Pressure	Change Element Every	Precede with Filtration Grade
AO	Coalescing & Dry Particulate	Down to 1 micron	0.5 mg/m ³ 0.5 ppm(w)	99.925%	<70 mbar (1 psi)	<125 mbar (1.8 psi)	12 months	WS (for bulk liquid)
AA	Coalescing & Dry Particulate	Down to 0.01 micron	0.01 mg/m ³ 0.01 ppm(w)	99.9999%	<70 mbar (1 psi)	<125 mbar (1.8 psi)	12 months	AO

Technical Data

Filtration Grade	Filter Models	Minimum Operating Pressure		Maximum Operating Pressure		Minimum Operating Temperature		Maximum Operating Temperature	
		bar g	psi g	bar g	psi g	°C	°F	°C	°F
AO/AA	P010 - P055 (Float Drain)	1	15	16	232	2	35	80	176
	P010 - P055 (Manual Drain)	1	15	20	290	2	35	80	176
	P060 (Float Drain)	1	15	16	232	2	35	66	150
	P060 (Manual Drain)	1	15	20	290	2	35	100	212

Flow Rates

Model	Pipe Size	L/S	m ³ /min	m ³ /hr	cfm	Replacement Element	No.
Grade P010A	I 1/4"	10	0.6	36	21	P010	1
Grade P010B	I 3/8"	10	0.6	36	21	P010	1
Grade P010C	I 1/2"	10	0.6	36	21	P010	1
Grade P015C	I 1/2"	20	1.2	72	42	P015	1
Grade P020C	I 1/2"	30	1.8	108	64	P020	1
Grade P020D	I 3/4"	30	1.8	108	64	P020	1
Grade P025D	I 3/4"	60	3.6	216	127	P025	1
Grade P025E	I 1"	60	3.6	216	127	P025	1
Grade P030G	I 1 1/2"	110	6.6	396	233	P030	1
Grade P035G	X 1 1/2"	160	9.6	576	339	P035	1
Grade P040H	X 2"	220	13.2	792	466	P040	1
Grade P045I	X 2 1/2"	330	19.8	1188	699	P045	1
Grade P050I	X 2 1/2"	430	25.9	1548	911	P050	1
Grade P055I	X 2 1/2"	620	37.3	2232	1314	P055	1
Grade P055J	X 3"	620	37.3	2232	1314	P055	1
Grade P060K	X 4"	1000	60	3600	2119	P060	3

Stated flows are for operation at 7 bar (g) (102 psi g) with reference to 20°C, 1 bar (a), 0% relative water vapour pressure. For flows at other pressures, apply the correction factors shown below.

Product Selection & Correction Factors

To correctly select a filter model, the flow rate of the filter must be adjusted for the minimum operating (inlet) pressure at the point of installation.

1. Obtain the minimum operating (inlet) pressure and maximum compressed air flow rate at the inlet of the filter.
2. Select the correction factor for minimum inlet pressure from the CFMIP table (always round down e.g. for 5.3 bar, use 5 bar correction factor)
3. Calculate the minimum filtration capacity. Minimum Filtration Capacity = Compressed Air Flow Rate x CFMIP
4. Using the minimum filtration capacity, select a filter model from the flow rate tables above (filter selected must have a flow rate equal to or greater than the minimum filtration capacity).

CFMIP - Correction Factor Minimum Inlet Pressure

Minimum Inlet Pressure	bar g	1	2	3	4	5	6	7	8	9	10	11	12	13	14	15	16	17	18	19	20
	psi g	15	29	44	58	73	87	100	116	131	145	160	174	189	203	218	232	248	263	277	290
Correction Factor		2.65	1.87	1.53	1.32	1.18	1.08	1.00	0.94	0.88	0.84	0.80	0.76	0.73	0.71	0.68	0.66	0.64	0.62	0.61	0.59

When ordering a filter for pressures above 16 bar (g) (232 psi g), use a manual drain. Replace F with M in product code. e.g. AOP015BGF becomes AOP015BGM. Models 150 - 500 are not suitable for pressures above 16 bar (g) (232 psi g).

Filter Coding Example

Grade	Model	Pipe Size	Thread	Drain Option	Incident Monitor Option
AO	P & 3 digit code denotes filter housing size	Letter denotes pipe size	G = BSPP N = NPT	F = Float M = Manual	I = Indicator X = None
Example code					
AO	P010	A	G	F	I

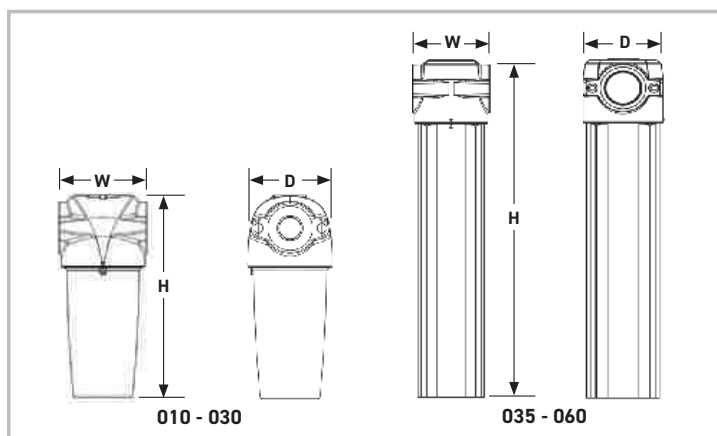

Weights & Dimensions

Model	Height (H)		Width (W)		Depth (D)		Weight	
	mm	ins	mm	ins	mm	ins	kg	lbs
010A	180	7.09	76	2.99	65	2.56	0.84	1.86
010B	180	7.09	76	2.99	65	2.56	0.84	1.84
010C	180	7.09	76	2.99	65	2.56	0.82	1.81
015C	238	9.37	89	3.5	84	3.31	1.16	2.55
020C	238	9.37	89	3.5	84	3.31	1.17	2.58
020D	238	9.37	89	3.5	84	3.31	1.44	3.19
025D	277	10.9	120	4.72	115	4.53	2.14	4.71
025E	277	10.9	120	4.72	115	4.53	2.69	5.92
030G	367	14.45	120	4.72	115	4.53	3.04	6.70
035G	440	20.9	164	6.46	157	6.18	6.90	15.21
040H	532	24.5	164	6.46	157	6.18	7.30	16.09
045I	532	24.5	164	6.46	157	6.18	7.10	15.65
050I	654	29.3	192	7.56	183	7.20	10.30	22.71
055I	844	36.8	192	7.56	183	7.20	15.90	33.05
055J	844	36.8	192	7.56	183	7.20	15.30	33.73
060K	847	33.3	420	16.54	282	11.10	44.50	98.11

Parker Catalogue Numbers (BSPP Models)

Model	Catalogue Number General Purpose Coalescing Filters	Catalogue Number General Purpose Dry Particulate Filters	Catalogue Number High Efficiency Coalescing Filters	Catalogue Number High Efficiency Dry Particulate Filters
P010A	AOP010AGFI	AOP010AGMI	AAP010AGFI	AAP010AGMI
P010B	AOP010BGFI	AOP010BGMI	AAP010BGFI	AAP010BGMI
P010C	AOP010CGFI	AOP010CGMI	AAP010CGFI	AAP010CGMI
P015C	AOP015CGFI	AOP015CGMI	AAP015CGFI	AAP015CGMI
P020C	AOP020CGFI	AOP020CGMI	AAP020CGFI	AAP020CGMI
P020D	AOP020DGFI	AOP020DGMI	AAP020DGFI	AAP020DGMI
P025D	AOP025DGFI	AOP025DGMI	AAP025DGFI	AAP025DGMI
P025E	AOP025EGFI	AOP025EGMI	AAP025EGFI	AAP025EGMI
P030G	AOP030GGFI	AOP030GGMI	AAP030GGFI	AAP030GGMI
P035G	AOP035GGFX	AOP035GGMX	AAP035GGFX	AAP035GGMX
P040H	AOP040HGFX	AOP040HGMX	AAP040HGFX	AAP040HGMX
P045I	AOP045IGFX	AOP045IGMX	AAP045IGFX	AAP045IGMX
P050I	AOP050IGFX	AOP050IGMX	AAP050IGFX	AAP050IGMX
P055I	AOP055IGFX	AOP055IGMX	AAP055IGFX	AAP055IGMX
P055J	AOP055JGFX	AOP055JGMX	AAP055JGFX	AAP055JGMX
P060K	AOP060KGFX	AOP060KGMX	AAP060KGFX	AAP060KGMX

OIL-X Coalescing / Dry Particulate / Oil Vapour Reduction Filters (Carbon Steel)

Filtration Performance

Filtration Grade	Filter Type	Particle Reduction (inc water & oil aerosols)	Max. Remaining Oil Content at 21°C (70°F)	Filtration Efficiency	Initial Dry Differential Pressure	Initial Saturated Differential Pressure	Change Element Every	Precede with Filtration Grade
AO	Coalescing & Dry Particulate	Down to 1 micron	0.5 mg/m ³ 0.5 ppm(w)	99.925%	<70 mbar (1 psi)	<125 mbar (1.8 psi)	12 months	WS (for bulk liquid)
AA	Coalescing & Dry Particulate	Down to 0.01 micron	0.01 mg/m ³ 0.01 ppm(w)	99.9999%	<70 mbar (1 psi)	<125 mbar (1.8 psi)	12 months	AO
ACS	Oil Vapour Reduction	N/A	0.003 mg/m ³ 0.003 ppm(w)	N/A	<140 mbar (2 psi)	N/A	When oil vapour is detected	AO+AA

Important Note:

Using the same filter housings as their coalescing and dry particulate counterparts in the OIL-X range, Grade ACS filter elements differ in that they utilise a deep wrapped bed of carbon cloth to adsorb oil vapour.

It is important to note, in-line adsorption filter elements have a different life span compared to coalescing and dry particulate filters and require more frequent element changes. Should a 12 month service period be required, Parker OIL-X Grade OVR oil vapour reduction filters are recommended.

Technical Data

Filtration Grade	Filter Models	Minimum Operating Pressure		Maximum Operating Pressure		Minimum Operating Temperature		Maximum Operating Temperature	
		bar g	psi g	bar g	psi g	°C	°F	°C	°F
AO/AA	065 - 095 (Electronic Drain)	1	15	16	232	2	35	60	140
	065 - 095 (Manual Drain)	1	15	16	232	2	35	100	212
ACS	065 - 095 (Manual Drain)	1	15	16	232	2	35	50	122

Flow Rates

Model	Pipe Size	L/S	m ³ /min	m ³ /hr	cfm	Replacement Element	No.
Grade 065ND <input type="checkbox"/> X	DN80	620	37.2	2232	1312	Grade	1
Grade 070OD <input type="checkbox"/> X	DN100	1240	74.4	4464	2625	Grade	2
Grade 075PD <input type="checkbox"/> X	DN150	1860	111.6	6696	3938	Grade	3
Grade 080PD <input type="checkbox"/> X	DN150	2480	148.8	8928	5251	Grade	4
Grade 085QD <input type="checkbox"/> X	DN200	3720	223.2	13392	7877	Grade	6
Grade 090RD <input type="checkbox"/> X	DN250	6200	372	22320	13129	Grade	10
Grade 095SD <input type="checkbox"/> X	DN300	8680	520.8	31248	18380	Grade	14

Filter Coding Example

Grade	Model	Pipe Size	Thread	Drain Option	Incident Monitor Option
AO AA ACS	3 digit code denotes filter housing size	Letter denotes pipe size	D = Din Flange	E = Electronic M = Manual	I = Indicator X = None
Example code					
AO	090	P	D	E	X

= Replace with drain type - E (electronic) or M (manual)

Stated flows are for operation at 7 bar (g) (102 psi g) with reference to 20°C, 1 bar (a), 0% relative water vapour pressure.

For flows at other pressures, apply the correction factors shown below.

Product Selection & Correction Factors

To correctly select a filter model, the flow rate of the filter must be adjusted for the minimum operating (inlet) pressure at the point of installation.

1. Obtain the minimum operating (inlet) pressure and maximum compressed air flow rate at the inlet of the filter.
2. Select the correction factor for minimum inlet pressure from the CFMIP table (always round down e.g. for 5.3 bar, use 5 bar correction factor)
3. Calculate the minimum filtration capacity. Minimum Filtration Capacity = Compressed Air Flow Rate x CFMIP
4. Using the minimum filtration capacity, select a filter model from the flow rate tables above (filter selected must have a flow rate equal to or greater than the minimum filtration capacity).

CFMIP - Correction Factor Minimum Inlet Pressure

Minimum Inlet Pressure	bar g	1	2	3	4	5	6	7	8	9	10	11	12	13	14	15	16
	psi g	15	29	44	58	73	87	100	116	131	145	160	174	189	203	218	232
Correction Factor		2.65	1.87	1.53	1.32	1.18	1.08	1.00	0.94	0.88	0.84	0.80	0.76	0.73	0.71	0.68	0.66

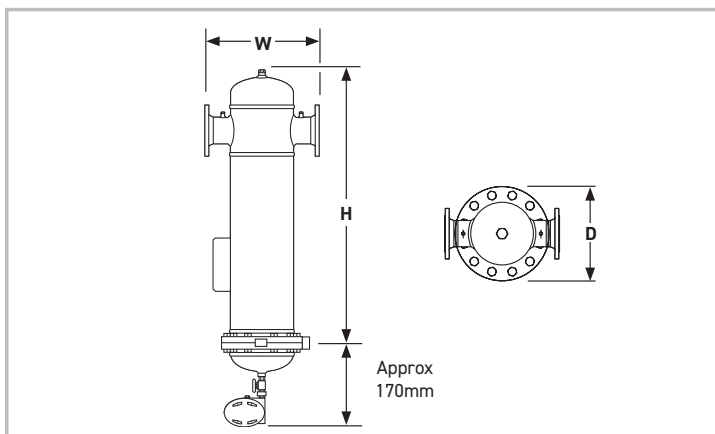

Weight & Dimensions

Model	Height (H)		Width (W)		Depth (D)		Weight	
	mm	ins	mm	ins	mm	ins	kg	lbs
065ND	1065	42	440	17.3	340	13.4	70	154
070OD	1152	45.4	500	19.7	405	16	97	214
075PD	1256	49.5	600	23.6	520	20.5	148	326
080PD	1332	52.4	650	25.6	580	22.8	187	412
085QD	1415	55.7	750	29.5	640	25.2	240	529
090RD	1603	63.1	1000	39.4	840	33	470	1036
095SD	1706	67.2	1050	41.3	910	35.8	580	1279

Parker Catalogue Numbers (No DPI)

Model	Catalogue Number General Purpose Coalescing Filters	Catalogue Number General Purpose Dry Particulate Filters	Catalogue Number High Efficiency Coalescing Filters	Catalogue Number High Efficiency Dry Particulate Filters	Catalogue Number Oil Vapour Reduction Filters
065N	AO065NDEX	AO065NDMX	AA065NDEX	AA065NDMX	ACS065NDMX
070O	AO070ODEX	AO070ODMX	AA070ODEX	AA070ODMX	ACS070ODMX
075P	AO075PDEX	AO075PDMX	AA075PDEX	AA075PDMX	ACS075PDMX
080P	AO080PDEX	AO080PDMX	AA080PDEX	AA080PDMX	ACS080PDMX
085Q	AO085QDEX	AO085QDMX	AA085QDEX	AA085QDMX	ACS085QDMX
090P	AO090RDEX	AO090RDMX	AA090RDEX	AA090RDMX	ACS090RDMX
095S	AO095SDEX	AO095SDMX	AA095SDEX	AA095SDMX	ACS095SDMX

Parker Catalogue Numbers (With DPI)

Model	Catalogue Number General Purpose Coalescing Filters	Catalogue Number General Purpose Dry Particulate Filters	Catalogue Number High Efficiency Coalescing Filters	Catalogue Number High Efficiency Dry Particulate Filters
065N	AO065NDEI	AO065NDMI	AA065NDEI	AA065NDMI
070O	AO070ODEI	AO070ODMI	AA070ODEI	AA070ODMI
075P	AO075PDEI	AO075PDMI	AA075PDEI	AA075PDMI
080P	AO080PDEI	AO080PDMI	AA080PDEI	AA080PDMI
085Q	AO085QDEI	AO085QDMI	AA085QDEI	AA085QDMI
090P	AO090RDEI	AO090RDMI	AA090RDEI	AA090RDMI
095S	AO095SDEI	AO095SDMI	AA095SDEI	AA095SDMI

OIL-X Point Of Use Oil Vapour Reduction Filters

Filtration Performance

Filtration Grade	Filter Type	Particle Reduction (inc water & oil aerosols)	Max. Remaining Oil Content at 21°C (70°F)	Filtration Efficiency	Initial Dry Differential Pressure	Initial Saturated Differential Pressure	Change Element Every	Precede with Filtration Grade
ACS	Oil Vapour Reduction	N/A	0.003 mg/m ³ 0.003 ppm(w)	N/A	<140 mbar (2 psi)	N/A	When oil vapour is detected	AO+AA

Technical Data

Filtration Grade	Filter Models	Minimum Operating Pressure		Maximum Operating Pressure		Minimum Operating Temperature		Maximum Operating Temperature	
		bar g	psi g	bar g	psi g	°C	°F	°C	°F
ACS	P010 - P055 (Manual Drain)	1	15	20	290	2	35	50	122
	P060 (Manual Drain)	1	15	20	290	2	35	50	122

Flow Rates

Model	Pipe Size	L/S	m ³ /min	m ³ /hr	cfm	Replacement Element	No.
ACSP010A <input type="checkbox"/> MX	¼"	10	0.6	36	21	P010ACS	1
ACSP010B <input type="checkbox"/> MX	⅜"	10	0.6	36	21	P010ACS	1
ACSP010C <input type="checkbox"/> MX	½"	10	0.6	36	21	P010ACS	1
ACSP015C <input type="checkbox"/> MX	½"	20	1.2	72	42	P015ACS	1
ACSP020C <input type="checkbox"/> MX	½"	30	1.8	108	64	P020ACS	1
ACSP020D <input type="checkbox"/> MX	¾"	30	1.8	108	64	P020ACS	1
ACSP025D <input type="checkbox"/> MX	¾"	60	3.6	216	127	P025ACS	1
ACSP025E <input type="checkbox"/> MX	1"	60	3.6	216	127	P025ACS	1
ACSP030G <input type="checkbox"/> MX	1½"	110	6.6	396	233	P030ACS	1
ACSP035G <input type="checkbox"/> MX	1½"	160	9.6	576	339	P035ACS	1
ACSP040H <input type="checkbox"/> MX	2"	220	13.2	792	466	P040ACS	1
ACSP045I <input type="checkbox"/> MX	2½"	330	19.8	1188	699	P045ACS	1
ACSP050I <input type="checkbox"/> MX	2½"	430	25.9	1548	911	P050ACS	1
ACSP055I <input type="checkbox"/> MX	2½"	620	37.3	2232	1314	P055ACS	1
ACSP055J <input type="checkbox"/> MX	3"	620	37.3	2232	1314	P055ACS	1
ACSP060K <input type="checkbox"/> MX	4"	1000	60	3600	2119	P060ACS	3

G = BSPP / N=NPT

Stated flows are for operation at 7 bar (g) (102 psi g) with reference to 20°C, 1 bar (a), 0% relative water vapour pressure. For flows at other pressures, apply the correction factors shown below.

Filter Coding Example

Grade	Model	Pipe Size	Thread	Drain Option	Incident Monitor Option
ACS	P & 3 digit code denotes filter housing size	Letter denotes pipe size	G = BSPP N = NPT	M = Manual	X = None
Example code					
ACS	P010	A	G	M	X

Product Selection & Correction Factors

To correctly select a filter model, the flow rate of the filter must be adjusted for the minimum operating (inlet) pressure at the point of installation.

1. Obtain the minimum operating (inlet) pressure and maximum compressed air flow rate at the inlet of the filter.
2. Select the correction factor for minimum inlet pressure from the CFMIP table (always round down e.g. for 5.3 bar, use 5 bar correction factor)
3. Calculate the minimum filtration capacity. Minimum Filtration Capacity = Compressed Air Flow Rate x CFMIP
4. Using the minimum filtration capacity, select a filter model from the flow rate tables above (filter selected must have a flow rate equal to or greater than the minimum filtration capacity).

CFMIP - Correction Factor Minimum Inlet Pressure

Minimum Inlet Pressure	bar g	1	2	3	4	5	6	7	8	9	10	11	12	13	14	15	16	17	18	19	20
	psi g	15	29	44	58	73	87	100	116	131	145	160	174	189	203	218	232	248	263	277	290
Correction Factor		2.65	1.87	1.53	1.32	1.18	1.08	1.00	0.94	0.88	0.84	0.80	0.76	0.73	0.71	0.68	0.66	0.64	0.62	0.61	0.59

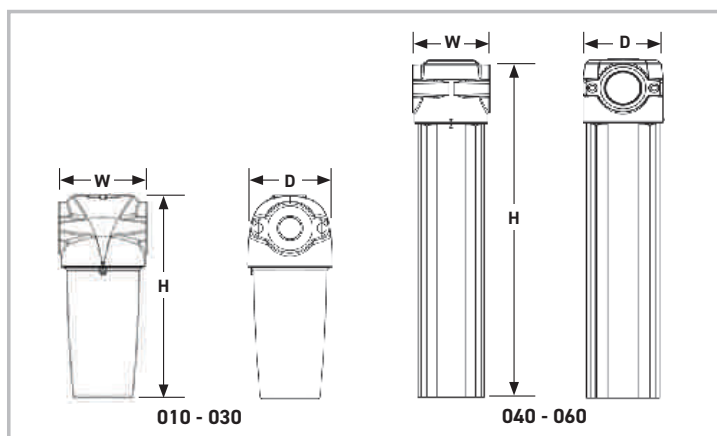

Weights & Dimensions

Model	Height (H)		Width (W)		Depth (D)		Weight	
	mm	ins	mm	ins	mm	ins	kg	lbs
010A	180	7.09	76	2.99	65	2.56	0.84	1.86
010B	180	7.09	76	2.99	65	2.56	0.84	1.84
010C	180	7.09	76	2.99	65	2.56	0.82	1.81
015C	238	9.37	89	3.5	84	3.31	1.16	2.55
020C	238	9.37	89	3.5	84	3.31	1.17	2.58
020D	238	9.37	89	3.5	84	3.31	1.44	3.19
025D	277	10.9	120	4.72	115	4.53	2.14	4.71
025E	277	10.9	120	4.72	115	4.53	2.69	5.92
030G	367	14.45	120	4.72	115	4.53	3.04	6.70
035G	440	20.9	164	6.46	157	6.18	6.90	15.21
040H	532	24.5	164	6.46	157	6.18	7.30	16.09
045I	532	24.5	164	6.46	157	6.18	7.10	15.65
050I	654	29.3	192	7.56	183	7.20	10.30	22.71
055I	844	36.8	192	7.56	183	7.20	15.90	33.05
055J	844	36.8	192	7.56	183	7.20	15.30	33.73
060K	847	33.3	420	16.54	282	11.10	44.50	98.11

Parker Catalogue Numbers (BSP Models)

Model	Catalogue Number Oil Vapour Reduction Filters
P010A	ACSP010AGMX
P010B	ACSP010BGMX
P010C	ACSP010CGMX
P015C	ACSP015CGMX
P020C	ACSP020CGMX
P020D	ACSP020DGMX
P025D	ACSP025DGMX
P025E	ACSP025EGMX
P030G	ACSP030GGMX
P035G	ACSP035GGMX
P040H	ACSP040HGMX
P045I	ACSP045IGMX
P050I	ACSP050IGMX
P055I	ACSP055IGMX
P055J	ACSP055JGMX
P060K	ACSP060KGMX

OIL-X OVR Plant Scale Oil Vapour Reduction

Filtration Performance

Filtration Grade	Filter Type	Particle Removal (inc Water & Oil Aerosols)	Max. Remaining Oil Content*	Filtration Efficiency	Initial Dry Differential Pressure	Initial Saturated Differential Pressure	Adsorbent Life	Precede with Grade
OVR	Oil Vapour Reduction	N/A	≤ 0.003 mg/m ³ ≤ 0.003 ppm (w)	N/A	<350 mbar <5 psi	N/A	*12 months	AO + AA

*At system operating temperature and when corrected to match system conditions.

Technical Data

Filtration Grade	Filter Models	Minimum Operating Pressure		Maximum Operating Pressure		Minimum Operating Temperature		Maximum Operating Temperature	
		bar g	psi g	bar g	psi g	°C	°F	°C	°F
OVR	300H <input type="checkbox"/> XX - 550I <input type="checkbox"/> XX	1	15	16	232	2	35	50	122

Flow Rates

Model	Pipe Size	L/s	m ³ /min	m ³ /hr	cfm	Replacement Cartridge	No. Required
OVR300H <input type="checkbox"/> XX	2"	87	5.2	314	185	300OVR	1
OVR350H <input type="checkbox"/> XX	2"	177	10.6	637	375	350OVR	1
OVR400H <input type="checkbox"/> XX	2"	354	21.2	1274	750	400OVR	1
OVR450I <input type="checkbox"/> XX	2½"	531	31.9	1911	1125	450OVR	1
OVR500I <input type="checkbox"/> XX	2½"	708	42.5	2549	1500	500OVR	1
OVR550I <input type="checkbox"/> XX	2½"	885	53.1	3186	1875	550OVR	1
2 x OVR550I <input type="checkbox"/> XX	2½"	1770	106.2	6371	3750	550OVR	2
3 x OVR550I <input type="checkbox"/> XX	2½"	2655	159.3	9557	5625	550OVR	3
4 x OVR550I <input type="checkbox"/> XX	2½"	3540	212.4	12743	7500	550OVR	4
5 x OVR550I <input type="checkbox"/> XX	2½"	4424	265.5	15928	9375	550OVR	5

G = BSPP / N=NPT

Stated flows are for operation at 7 bar (g) (102 psi g) with reference to 20°C, 1 bar (a), 0% relative water vapour pressure. For flows at other pressures, apply the correction factors shown on the right.

Product Selection & Correction Factors

1. System Information Required for OVR Sizing & Selection

- Minimum pressure at the inlet of the OVR
- Maximum inlet temperature at the inlet of the OVR (highest summer inlet temp)
- Dewpoint of the compressed air (is the OVR to be installed before or after a dryer)
- Compressor type (oil lubricated or oil free)
- Maximum compressed air flow rate
- Oil vapour concentration expected at the inlet of the OVR (default is 0.05 mg/m³)

2. Select Correction Factors

- For minimum inlet pressure, select a correction factor from the CFMIP table that corresponds to the minimum inlet pressure of the compressed air system, remembering to always round down e.g. for 5.3 bar g use the 5 bar g correction factor.
- For maximum inlet temperature there are two tables, one for use with an oil lubricated compressor, the other for oil free compressor. Select a correction factor from the CFMIT table for the relevant compressor type, remembering to always round up e.g. for 37°C use the 40°C correction factor.
- For pressure dewpoint, select a correction factor from the CFID table.
- For oil vapour concentration, select a correction factor from the CFIV table, remembering to always round up e.g. for 3.25g/m³ use the correction factor for 4mg/m³.

3. Calculate Minimum Filtration capacity

- Minimum Filtration Capacity = Compressed Air Flow x CFMIT x CFMIP x CFID x CFIV.
- Using the minimum filtration capacity, select an OVR model from the flow rate tables. The OVR model selected must have a flow rate equal to or greater than the minimum filtration capacity.
- If the minimum filtration capacity exceeds the maximum values of the models shown within the tables, please contact Parker for advice regarding larger multi-banked units.

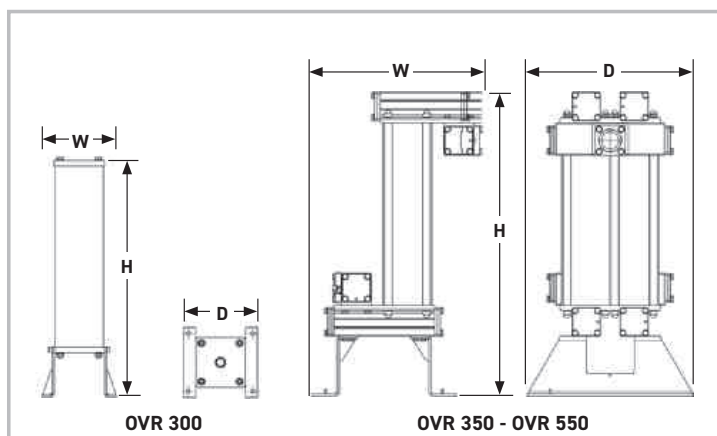

Correction Factors Maximum Inlet Temperature (CFMIT)

Oil Lubricated Compressors			Oil-Free Compressors		
°C	°F	Correction Factor	°C	°F	Correction Factor
25	77	1.00	25	77	1.00
30	86	1.00	30	86	1.00
35	95	1.00	35	95	1.00
40	104	1.25	40	104	1.02
45	113	1.55	45	113	1.04
50	122	1.90	50	122	1.05

Correction Factor Minimum Inlet Pressure (CFMIP)

Minimum Inlet Pressure	bar g	3	4	5	6	7	8	9	10	11	12	13	14	15	16
	psi g	44	58	73	87	100	116	131	145	160	174	189	203	218	232
Correction Factor	2.00	1.60	1.33	1.14	1.00	1.00	1.00	1.00	1.00	1.00	1.00	1.00	1.00	1.00	1.00

Correction Factor Dewpoint (CFID)

Installation	Correction Factor
After Dryer	1.00
Before Dryer	4.00

Correction Factor Inlet Vapour Content (CFIV)

Inlet Vapour Concentration mg/m ³	0.05	0.1	0.2	0.3	0.4	0.5	0.6	0.7	0.8	0.9	1.0	2.0	3.0	4.0	5.0
	Correction Factor	1	2	4	6	8	10	12	14	16	18	20	40	60	80

Weight & Dimensions

Models	Height (H)		Width (W)		Depth (D)		Weight	
	mm	ins	mm	ins	mm	ins	kg	lbs
OVR300	792	31.2	245	9.6	230	9.1	28.5	62.8
OVR350	1009	39.7	590	23.2	550	21.7	62.5	137.8
OVR400	1009	39.7	735	28.9	550	21.7	71.5	157.6
OVR450	1009	39.7	888	35.0	550	21.7	92.8	204.6
OVR500	1009	39.7	1065	41.9	550	21.7	100.6	221.8
OVR550	1009	39.7	1234	48.6	550	21.7	122.0	269.0

Parker Catalogue Numbers

Model	Catalogue Number Plant Scale Oil Vapour Reduction (BSPP)	Catalogue Number Plant Scale Oil Vapour Reduction (NPT)
OVR300	OVR300HGXX	OVR300HNXX
OVR350	OVR350HGXX	OVR350HNXX
OVR400	OVR400HGXX	OVR400HNXX
OVR450	OVR450IGXX	OVR450INXX
OVR500	OVR500IGXX	OVR500INXX
OVR550	OVR550IGXX	OVR550INXX

OIL-X Combination Filters

Filtration Performance

Filtration Grade	Filter Type	Particle Reduction (inc water & oil aerosols)	Max. Remaining Oil Content at 21°C (70°F)	Filtration Efficiency	Initial Dry Differential Pressure	Initial Saturated Differential Pressure	Change Element Every	Precede with Filtration Grade
AC	High Efficiency Coalescing & Oil Vapour Reduction	Down to 0.01 micron	Aerosols 0.01 mg/m ³ 0.01 ppm(w) Vapour 0.003 mg/m ³ 0.003 ppm(w)	N/A	<618 mbar (9 psi)	<773 mbar (11 psi)	Coalescing Element 12 Months Oil Vapour Reduction Element When oil vapour is detected	AO

Technical Data

Filtration Grade	Filter Models	Minimum Operating Pressure		Maximum Operating Pressure		Minimum Operating Temperature		Maximum Operating Temperature	
		bar g	psi g	bar g	psi g	°C	°F	°C	°F
AC	010 - 030 (Float Drain)	1	15	16	232	2	35	30	86
	010 - 030 (Manual Drain)	1	15	20	290	2	35	30	86

Flow Rates

Model	Pipe Size	L/S	m ³ /min	m ³ /hr	cfm	Replacement Elements	
AC010A <input type="checkbox"/> FX	¼"	6	0.4	22	13	010AA	010AC
AC010B <input type="checkbox"/> FX	⅜"	6	0.4	22	13	010AA	010AC
AC010C <input type="checkbox"/> FX	½"	6	0.4	22	13	010AA	010AC
AC015B <input type="checkbox"/> FX	⅜"	13	0.8	46	27	015AA	015AC
AC015C <input type="checkbox"/> FX	½"	13	0.8	46	27	015AA	015AC
AC020C <input type="checkbox"/> FX	½"	25	1.5	90	53	020AA	020AC
AC020D <input type="checkbox"/> FX	¾"	25	1.5	90	53	020AA	020AC
AC020E <input type="checkbox"/> FX	1"	25	1.5	90	53	020AA	020AC
AC025D <input type="checkbox"/> FX	¾"	40	2.4	143	84	025AA	025AC
AC025E <input type="checkbox"/> FX	2"	65	3.9	231	136	025AA	025AC
AC030E <input type="checkbox"/> FX	1"	85	5.1	305	180	030AA	030AC
AC030F <input type="checkbox"/> FX	1¼"	85	5.1	305	180	030AA	030AC
AC030F <input type="checkbox"/> FX	1½"	85	5.1	305	180	030AA	030AC

G = BSPP / N=NPT

Stated flows are for operation at 7 bar (g) (102 psi g) with reference to 20°C, 1 bar (a), 0% relative water vapour pressure. For flows at other pressures, apply the correction factors shown below.

Product Selection & Correction Factors

To correctly select a filter model, the flow rate of the filter must be adjusted for the minimum operating (inlet) pressure at the point of installation.

1. Obtain the minimum operating (inlet) pressure and maximum compressed air flow rate at the inlet of the filter.
2. Select the correction factor for minimum inlet pressure from the CFMIP table (always round down e.g. for 5.3 bar, use 5 bar correction factor)
3. Calculate the minimum filtration capacity. Minimum Filtration Capacity = Compressed Air Flow Rate x CFMIP
4. Using the minimum filtration capacity, select a filter model from the flow rate tables above (filter selected must have a flow rate equal to or greater than the minimum filtration capacity).

CFMIP - Correction Factor Minimum Inlet Pressure

Minimum Inlet Pressure	bar g	1	2	3	4	5	6	7	8	9	10	11	12	13	14	15	16	17	18	19	20
	psi g	15	29	44	58	73	87	100	116	131	145	160	174	189	203	218	232	248	263	277	290
Correction Factor		2.65	1.87	1.53	1.32	1.18	1.08	1.00	0.94	0.88	0.84	0.80	0.76	0.73	0.71	0.68	0.66	0.64	0.62	0.61	0.59

When ordering a filter for pressures above 16 bar g (232 psi g), use a manual drain. Replace F with M in product code. e.g. AC015BGFX becomes AC015BGMX.

Filter Coding Example

Grade	Model	Pipe Size	Thread	Drain Option	Incident Monitor Option
AC	3 digit code denotes filter housing size	Letter denotes pipe size	G = BSPP N = NPT	F = Float	X = None
Example code					
AC	010	A	G	F	X

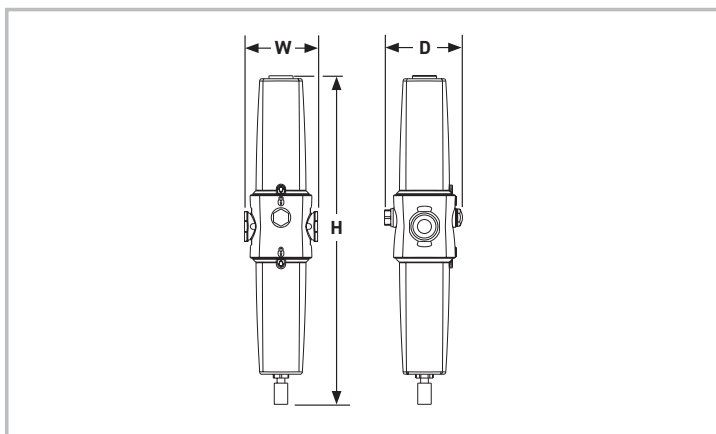

Weight & Dimensions

Model	Height (H)		Width (W)		Depth (D)		Weight	
	mm	ins	mm	ins	mm	ins	kg	lbs
AC010A	311	12.3	76	3.0	65	2.6	0.8	1.8
AC010B	311	12.3	76	3.0	65	2.6	0.8	1.8
AC010C	311	12.3	76	3.0	65	2.6	0.8	1.8
AC015B	474	18.7	97	3.8	84	3.3	1.6	3.5
AC015C	474	18.7	97	3.8	84	3.3	1.6	3.5
AC020C	474	18.7	97	3.8	84	3.3	1.4	3.2
AC020D	474	18.7	97	3.8	84	3.3	1.4	3.2
AC020E	474	18.7	97	3.8	84	3.3	1.4	3.2
AC025D	554	21.8	129	5.1	115	4.5	3.5	7.8
AC025E	554	21.8	129	5.1	115	4.5	3.4	7.6
AC030E	733	28.9	129	5.1	115	4.5	4.1	9.0
AC030F	733	28.9	129	5.1	115	4.5	4.1	9.0
AC030F	733	28.9	129	5.1	115	4.5	4.1	9.0

Parker Catalogue Numbers (BSPP Models)

Model	Catalogue Number Double Stage Oil Vapour Reduction Filers
AC010A	AC010AGFX
AC010B	AC010BGFX
AC010C	AC010CGFX
AC015B	AC015BGFX
AC015C	AC015CGFX
AC020C	AC020CGFX
AC020D	AC020DGFX
AC020E	AC020EGFX
AC025D	AC025DGFX
AC025E	AC025EGFX
AC030FG	AC030FGFX
AC030G	AC030GGFX

Hyperfilter Die-cast Aluminium Filters

Filtration Performance

Filtration Grade	Filter Type	Particle Reduction (inc water & oil aerosols)	Max. Remaining Oil Content at 21°C (70°F)	Filtration Efficiency	Initial Dry Differential Pressure	Initial Saturated Differential Pressure	Change Element Every	Precede with Filtration Grade
Q	Coalescing & Dry Particulate	Down to 3 micron	N/A	N/A	<70 mbar (<1 psi)	<140 mbar (<2 psi)	12 months	WS (for bulk liquid)
P	Coalescing & Dry Particulate	Down to 1 micron	0.6 mg/m ³ 0.5 ppm(w)	99.9%	<70 mbar (<1 psi)	<140 mbar (<2 psi)	12 months	Q
S	Coalescing & Dry Particulate	Down to 0.01 micron	0.01 mg/m ³ 0.01 ppm(w)	99.9999%	<100 mbar (<1.45 psi)	<200 mbar (<3 psi)	12 months	P
D	Dry Particulate downstream of adsorption dryer	Down to 3 micron	N/A	99.9%	<70 mbar (<1 psi)	N/A	12 months	-
C	Adsorption	N/A	0.003 mg/m ³ 0.003 ppm(w) of Oil Vapour	N/A	<350 mbar (<5 psi)	N/A	When oil vapour is detected	P+S

Technical Data

Filtration Grade	Filter Models	Minimum Operating Pressure		Maximum Operating Pressure		Minimum Operating Temperature		Maximum Operating Temperature	
		bar g	psi g	bar g	psi g	°C	°F	°C	°F
Q/P/S/D	HFN005 - HFN370	1	15	16	232	2	35	65	149
C	HFN005 - HFN370	1	15	16	232	2	35	50	122

Flow Rates

Model	Pipe Size	L/S	m ³ /min	m ³ /hr	cfm	Replacement Element	No.
HFN005	Grade WD ¼"	8.8	0.5	31.8	18	Grade 005-ELZ	1
HFN010	Grade WD ⅜"	16.7	1.0	60	35	Grade 010-ELZ	1
HFN018	Grade WD ½"	30.0	1.8	108	63	Grade 018-ELZ	1
HFN022	Grade WD ½"	36.7	2.2	132	77	Grade 022-ELZ	1
HFN030	Grade WD ½"	50.0	3.0	180	106	Grade 030-ELZ	1
HFN045	Grade WD ¾"	75.0	4.5	270	159	Grade 045-ELZ	1
HFN062	Grade WD ¾"	103.3	6.2	372	219	Grade 062-ELZ	1
HFN072	Grade WD 1"	120.0	7.2	432	254	Grade 072-ELZ	1
HFN122	Grade WD 1½"	203.3	12.2	732	430	Grade 122-ELZ	1
HFN135	Grade WD 1½"	225.0	13.5	810	477	Grade 135-ELZ	1
HFN175	Grade WD 2"	291.7	17.5	1050	618	Grade 175-ELZ	1
HFN205	Grade WD 2½"	341.7	20.5	1230	724	Grade 205-ELZ	1
HFN300	Grade WD 2½"	500.0	30.0	1800	1059	Grade 300-ELZ	1
HFN370	Grade WD 3"	611.1	37.0	2220	1295.0	Grade 370-ELZ	1

Filter Coding Example

Grade	Part Number
Q	HFN018QWD
P	HFN018PWD
S	HFN018SWD
D	HFN018DWD
C	HFN018CWD

Stated flows are for operation at 7 bar (g) (102 psi g) with reference to 20°C, 1 bar (a), 0% relative water vapour pressure. For flows at other pressures, apply the correction factors shown below.

Product Selection & Correction Factors

To correctly select a filter model, the flow rate of the filter must be adjusted for the minimum operating (inlet) pressure at the point of installation.

1. Obtain the minimum operating (inlet) pressure and maximum compressed air flow rate at the inlet of the filter.
2. Select the correction factor for minimum inlet pressure from the CFMIP table (always round down e.g. for 5.3 bar, use 5 bar correction factor)
3. Calculate the minimum filtration capacity. Minimum Filtration Capacity = Compressed Air Flow Rate x CFMIP
4. Using the minimum filtration capacity, select a filter model from the flow rate tables above (filter selected must have a flow rate equal to or greater than the minimum filtration capacity).

CFMIP - Correction Factor Minimum Inlet Pressure

Minimum Inlet Pressure	bar g	1	2	3	4	5	6	7	8	9	10	11	12	13	14	15	16
	psi g	15	29	44	58	73	87	100	116	131	145	160	174	189	203	218	232
Correction Factor		2.65	1.87	1.53	1.32	1.18	1.08	1.00	0.94	0.88	0.84	0.80	0.76	0.73	0.71	0.68	0.66

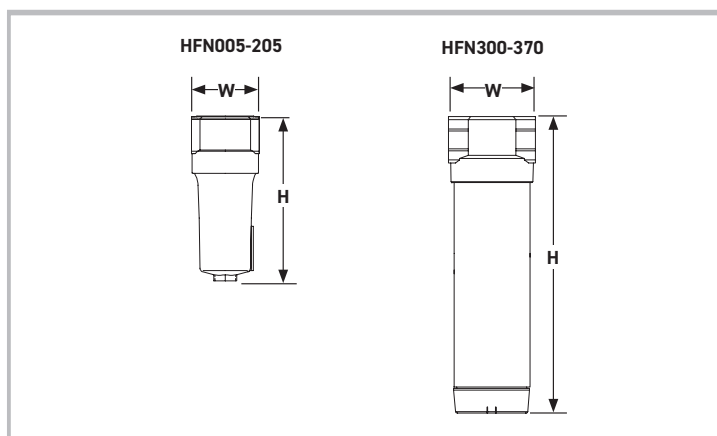

Filtration Tested In Accordance With

Filtration Grade	Q	P	S	D	C
Filter Type	Coalescing & Dry Particulate	Coalescing & Dry Particulate	Coalescing & Dry Particulate	Dry Particulate	Adsorption
Test Methods Used	ISO8573-2	ISO8573-2	ISO8573-2	N/A	N/A
ISO12500-1 Inlet Challenge Concentration	N/A Not Tested to ISO 12500-1	N/A Not Tested to ISO 12500-1	N/A Not Tested to ISO 12500-1	N/A	N/A

Weight & Dimensions

Model	Height (H)		Width (W)		Weight	
	mm	ins	mm	ins	kg	lbs
HFN005	168	6.6	69	2.7	0.6	1.3
HFN010	267	10.5	89	3.5	1.2	2.6
HFN018	267	10.5	89	3.5	1.2	2.6
HFN022	267	10.5	89	3.5	1.2	2.6
HFN030	367	14.4	109	4.3	2.4	5.3
HFN045	367	14.4	109	4.3	2.4	5.3
HFN062	514	20.2	109	4.3	3.0	6.6
HFN072	514	20.2	109	4.3	3.0	6.6
HFN122	550	21.6	150	5.9	5.2	11.5
HFN135	550	21.6	150	5.9	5.2	11.5
HFN175	928	36.5	150	5.9	6.5	14.3
HFN205	928	36.5	150	5.9	6.6	14.5
HFN300	733	28.8	188	7.4	13.5	29.8
HFN370	933	36.7	188	7.4	16.0	35.3

0003G Micro Filters

Filtration Performance

Filtration Grade	Filter Type	Particle Reduction (inc water & oil aerosols)	Max Remaining Oil Content at 21°C (70°F)	Filtration Efficiency	Initial Dry Differential Pressure	Initial Saturated Differential Pressure	Change Element Every	Precede with Filtration Grade
AO	Coalescing & Dry Particulate	Down to 1 micron	0.5 mg/m ³ 0.5 ppm(w)	99.925%	<70 mbar (<1 psi)	<140 mbar (<2 psi)	12 months	-
AA	Coalescing & Dry Particulate	Down to 0.01 micron	0.01 mg/m ³ 0.01 ppm(w)	99.9999%	<140 mbar (<1.5 psi)	<200 mbar (<3 psi)	12 months	AO
ACS	Oil Vapour Reduction	N/A	0.003 mg/m ³ 0.003 ppm(w)	N/A	<140 mbar (<1.5 psi)	N/A	When oil vapour is detected	AO+AA

Important Note:

Using the same filter housings as their coalescing and dry particulate counterparts, Grade ACS filter elements differ in that they utilise a wrapped bed of carbon cloth to adsorb oil vapour. It is important to note, in-line adsorption filter elements have a different life span compared to coalescing and dry particulate filters and require more frequent element changes.

Technical Data

Filtration Grade	Filter Models	Minimum Operating Pressure		Maximum Operating Pressure		Minimum Operating Temperature		Maximum Operating Temperature	
		bar g	psi g	bar g	psi g	°C	°F	°C	°F
AO/AA	0003G	1	14.5	10	145	2	35	50	122
ACS	0003G	1	14.5	10	145	2	35	30	86

Flow Rates

Model	Pipe Size	L/S	m ³ /min	m ³ /hr	cfm	Replacement Element	No.
AO-0003G	8mm Push In	3	0.18	11	6	K003AO	1
AA-0003G	8mm Push In	3	0.18	11	6	K003AA	1
ACS-0003G	8mm Push In	3	0.18	11	6	K003ACS	1

All models include a manual / constant bleed drain

Stated flows are for operation at 7 bar (g) (102 psi g) with reference to 20°C, 1 bar (a), 0% relative water vapour pressure. For flows at other pressures, apply the correction factors shown below.

Product Selection & Correction Factors

To correctly select a filter model, the flow rate of the filter must be adjusted for the minimum operating (inlet) pressure at the point of installation.

1. Obtain the minimum operating (inlet) pressure and maximum compressed air flow rate at the inlet of the filter.
2. Select the correction factor for minimum inlet pressure from the CFMIP table (always round down e.g. for 5.3 bar, use 5 bar correction factor)
3. Calculate the minimum filtration capacity. Minimum Filtration Capacity = Compressed Air Flow Rate x CFP
4. Using the minimum filtration capacity, select a filter model from the flow rate tables above (filter selected must have a flow rate equal to or greater than the minimum filtration capacity).

CFMIP - Correction Factor Minimum Inlet Pressure

Minimum Inlet Pressure	bar g	1	2	3	4	5	6	7	8	9	10
	psi g	15	29	44	58	73	87	100	116	131	145
Correction Factor		2.65	1.87	1.53	1.32	1.18	1.08	1.00	0.94	0.88	0.84

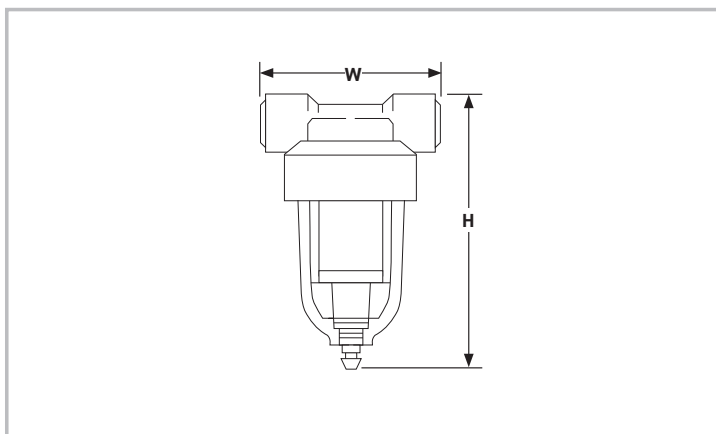

Weight & Dimensions

Model	Height (H)		Width (W)		Depth (D)		Weight	
	mm	ins	mm	ins	mm	ins	kg	lbs
0003G	89	3.5	58	2.3	56	2.2	0.1	0.2

Parker Catalogue Numbers

Model	Catalogue Number General Purpose Coalescing Filters	Catalogue Number General Purpose Dry Particulate Filters
0003G	AO-0003G	AA-0003G

OIL-X Filter Accessories

Filter Wall Mount Brackets

(for single filters)

Part Number	Filter Model / Number of
MBK1-1	010 x 1
MBK2-1	015-020 x 1
MBK3-1	025-030 x 1
MBK4-1	035-045 x 1
MBK5-1	050-055 x 1

Filter Wall Mount Brackets

(for 2 or 3 in series)

Part Number	Filter Model / Number of
MBK1-2	010 x 2 and x 3
MBK2-2	015-020 x 2 and x 3
MBK3-2	025 - 030 x 2 and x 3
MBK4-2	035 - 045 x 2 and x 3
MBK5-2	050 - 055 x 2 and x 3

Automatic Float and Manual Drains

Part Number	Description
PD15NO	Float Auto 010-055
EM1	Manual Drain 010-055 (Maximum Operating Pressure 20 bar g)
HDF120A	Float Auto 060
605006470	Manual Drain 060

Zero Loss ED Electronic Drains

Part Number	Filter Model
ED3002-G230	010 to 030
ED3004-G230	035 to 055
ED3007-G230	60
MK-G15-G10I	ED3002 Mounting kit G½
MK-G25-G15	ED3004-3100 Mounting kit G½

Unless stated otherwise all differential pressure monitors, gauges and drains have a maximum operating pressure of 16 bar g.

K-MT Small Flow Heatless Adsorption Dryers

Dryer Performance

Dryer Models	Dewpoint (Standard)		ISO8573-1:2010 Classification (Standard)	Dewpoint (Option 1)		ISO8573-1:2010 Classification (Option 1)	Dewpoint (Option 2)		ISO8573-1:2010 Classification (Option 2)
	°C	°F		°C	°F		°C	°F	
K-MT 1 - 4	-40	-40	Class 2.2.2	-70	-100	Class 2.1.2	-20	-4	Class 2.3.2

ISO8573-1 Classifications when used with OIL-X pre / post filtration

Technical Data

Dryer Models	Minimum Operating Pressure		Maximum Operating Pressure		Minimum Operating Temperature		Maximum Operating Temperature		Maximum Ambient Temperature		Electrical Supply (Standard)	Electrical Supply (Optional)	Thread Type	Noise Level dB(A)
	bar g	psi g	bar g	psi g	°C	°F	°C	°F	°C	°F				
K-MT 1 - 4	5	73	16	232	5	41	50	122	50	122	230V 1ph 50/60Hz	115V 1ph 50/60Hz	BSPP	65-86

Flow Rates

Model	Pipe Size BSPP or NPT	Inlet Flow Rate			
		L/s	m³/min	m³/hr	cfm
K-MT 1	G¼	2	0.13	8	5
K-MT 2	G¼	4	0.25	15	9
K-MT 3	G¼	7	0.42	25	15
K-MT 4	G¼	10	0.58	35	21

Stated flows are for operation at 7 bar (g) (102 psi g) with reference to 20°C, 1 bar (a), 0% relative water vapour pressure. For flows at other pressures, apply the correction factors shown below.

Product Selection & Correction Factors

For correct operation, compressed air dryers must be sized using for the maximum (summer) inlet temperature, maximum (summer) ambient temperature, minimum inlet pressure, required outlet dewpoint and maximum flow rate of the installation.

To select a dryer, first calculate the MDC (Minimum Drying Capacity) using the formula below then select a dryer from the flow rate table above with a flow rate equal to or above the MDC.

$$\text{Minimum Drying Capacity} = \text{System Flow} \times \text{CFMIT} \times \text{CFMAT} \times \text{CFMIP} \times \text{CFOD}$$

CFMIT - Correction Factor Maximum Inlet Temperature

Maximum Inlet Temperature	°C	25	30	35	40	45	50
	°F	77	86	95	104	113	122
Correction Factor		0.94	0.95	1.00	1.15	1.22	1.28

CFMAT - Correction Factor Maximum Ambient Temperature

Maximum Ambient Temperature	°C	25	30	35	40	45	50
	°F	77	86	95	104	113	122
Correction Factor		1.00	1.00	1.00	1.00	1.00	1.00

CFMIP - Correction Factor Minimum Inlet Pressure

Minimum Inlet Pressure	bar g	5	6	7	8	9	10	11	12	13	14	15	16
	psi g	73	87	100	116	131	145	160	174	189	203	218	232
Correction Factor		1.33	1.12	1.00	0.88	0.79	0.76	0.74	0.67	0.62	0.59	0.56	0.53

CFOD - Correction Factor Outlet Dewpoint

Outlet Dewpoint	°C	-20	-40	-70
	°F	-4	-40	-100
Correction Factor		1.00	1.00	2.00

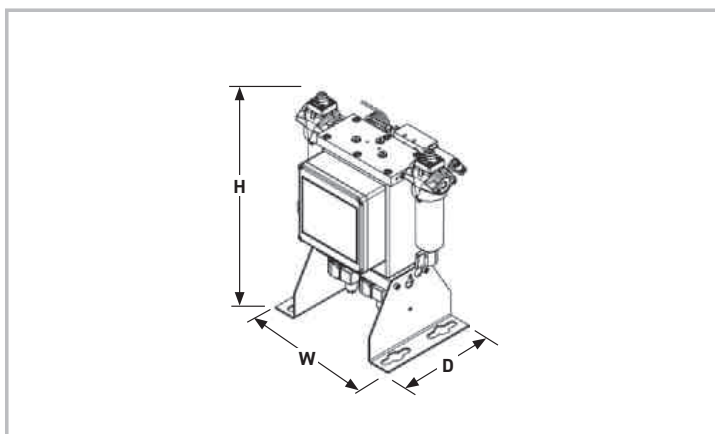

Weights & Dimensions

Model	Dimensions						Weight	
	Height (H)		Width (W)		Depth (D)			
	mm	ins	mm	ins	mm	ins	kg	lbs
K-MT 1	400	15.75	326	12.86	216	8.5	11.5	25.35
K-MT 2	575	22.65	326	12.86	216	8.5	15.5	34.20
K-MT 3	825	32.5	326	12.86	216	8.5	20.0	44.10
K-MT 4	1075	42.35	326	12.86	216	8.5	25.0	55.10

Required Filtration

Model	Pipe Size BSP or NPT	Dryer Inlet
		General Purpose Pre-filter
K-MT 1	¼"	AOP010A
K-MT 2	¼"	AOP010A
K-MT 3	¼"	AOP010A
K-MT 4	¼"	AOP010A

Included Filtration

Dryer Inlet	Dryer Outlet		
	High Efficiency Filter	Oil Vapour Reduction Filter	General Purpose Dry Particulate Filter
AAP010A	-	AOP010A	-
AAP010A	-	AOP010A	-
AAP010A	-	AOP010A	-
AAP010A	-	AOP010A	-

Parker Catalogue Numbers 230V/1ph/50Hz-60Hz

For Dryer Model	Catalogue Number No Dewpoint Sensor	Catalogue Number With Dewpoint Sensor
K-MT 1	K1/16D3-G230M	K1/16D3-G230MT
K-MT 2	K2/16D3-G230M	K2/16D3-G230MT
K-MT 3	K3/16D3-G230M	K3/16D3-G230MT
K-MT 4	K4/16D3-G230M	K4/16D3-G230MT

KA-MT Small Flow Heatless Adsorption Dryers

Dryer Performance

Dryer Models	Dewpoint (Standard)		ISO8573-1:2010 Classification (Standard)	Dewpoint (Option 1)		ISO8573-1:2010 Classification (Option 1)	Dewpoint (Option 2)		ISO8573-1:2010 Classification (Option 2)
	°C	°F		°C	°F		°C	°F	
KA-MT 1 - 4	-40	-40	Class 2.2.2	-70	-100	Class 2.1.2	-20	-4	Class 2.3.2

ISO8573-1 Classifications when used with OIL-X pre / post filtration

Technical Data

Dryer Models	Minimum Operating Pressure		Maximum Operating Pressure		Minimum Operating Temperature		Maximum Operating Temperature		Maximum Ambient Temperature		Electrical Supply (Standard)	Electrical Supply (Optional)	Thread Type	Noise Level dB(A)
	bar g	psi g	bar g	psi g	°C	°F	°C	°F	°C	°F				
KA-MT 1 - 4	5	73	16	232	5	41	50	122	50	122	230V 1ph 50/60Hz	115V 1ph 50/60Hz	BSPP	65-86

Flow Rates

Model	Pipe Size BSPP or NPT	Inlet Flow Rate			
		L/s	m³/min	m³/hr	cfm
KA-MT 1	G¼	2	0.13	8	5
KA-MT 2	G¼	4	0.25	15	9
KA-MT 3	G¼	7	0.42	25	15
KA-MT 4	G¼	10	0.58	35	21

Stated flows are for operation at 7 bar (g) (102 psi g) with reference to 20°C, 1 bar (a), 0% relative water vapour pressure. For flows at other pressures, apply the correction factors shown below.

Product Selection & Correction Factors

For correct operation, compressed air dryers must be sized using for the maximum (summer) inlet temperature, maximum (summer) ambient temperature, minimum inlet pressure, required outlet dewpoint and maximum flow rate of the installation.

To select a dryer, first calculate the MDC (Minimum Drying Capacity) using the formula below then select a dryer from the flow rate table above with a flow rate equal to or above the MDC.

$$\text{Minimum Drying Capacity} = \text{System Flow} \times \text{CFMIT} \times \text{CFMAT} \times \text{CFMIP} \times \text{CFOD}$$

CFMIT - Correction Factor Maximum Inlet Temperature

Maximum Inlet Temperature	°C	25	30	35	40	45	50
	°F	77	86	95	104	113	122
Correction Factor		0.94	0.95	1.00	1.15	1.22	1.28

CFMAT - Correction Factor Maximum Ambient Temperature

Maximum Ambient Temperature	°C	25	30	35	40	45	50
	°F	77	86	95	104	113	122
Correction Factor		1.00	1.00	1.00	1.00	1.00	1.00

CFMIP - Correction Factor Minimum Inlet Pressure

Minimum Inlet Pressure	bar g	5	6	7	8	9	10	11	12	13	14	15	16
	psi g	73	87	100	116	131	145	160	174	189	203	218	232
Correction Factor		1.33	1.12	1.00	0.88	0.79	0.76	0.74	0.67	0.62	0.59	0.56	0.53

CFOD - Correction Factor Outlet Dewpoint

Outlet Dewpoint	°C	-20	-40	-70
	°F	-4	-40	-100
Correction Factor		1.00	1.00	2.00

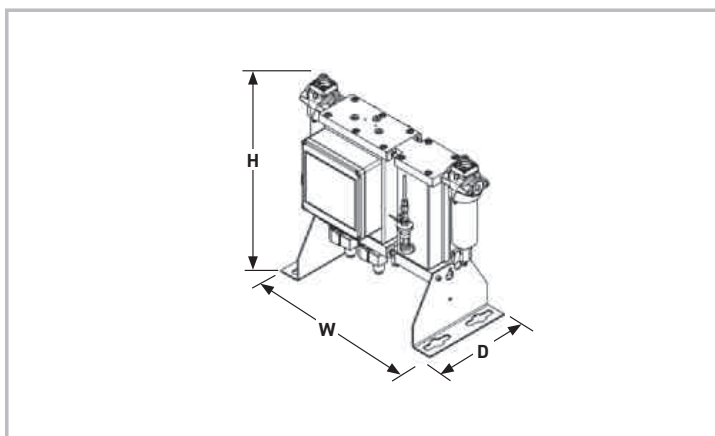

Weights & Dimensions

Model	Dimensions						Weight	
	Height (H)		Width (W)		Depth (D)			
	mm	ins	mm	ins	mm	ins	kg	lbs
KA-MT 1	400	15.75	459	18.1	216	8.5	15	33
KA-MT 2	575	22.65	459	18.1	216	8.5	20	44
KA-MT 3	825	32.5	459	18.1	216	8.5	28	62
KA-MT 4	1075	42.35	459	18.1	216	8.5	35	77

Required Filtration

Model	Pipe Size BSPP or NPT	Dryer Inlet
		General Purpose Pre-filter
KA-MT 1	¼"	AOP010A
KA-MT 2	¼"	AOP010A
KA-MT 3	¼"	AOP010A
KA-MT 4	¼"	AOP010A

Included Filtration

Dryer Inlet	Dryer Outlet			
	High Efficiency Filter	Oil Vapour Reduction Filter	General Purpose Dry Particulate Filter	High Efficiency Dry Particulate Filter
AAP010A	-	-	AOP010A	-
AAP010A	-	-	AOP010A	-
AAP010A	-	-	AOP010A	-
AAP010A	-	-	AOP010A	-

Parker Catalogue Numbers 230V/1ph/50Hz-60Hz

For Dryer Model	Catalogue Number No Dewpoint Sensor	Catalogue Number With Dewpoint Sensor
KA-MT 1	K1/16DA3-G230M	K1/16DA3-G230MT
KA-MT 2	K2/16DA3-G230M	K2/16DA3-G230MT
KA-MT 3	K3/16DA3-G230M	K3/16DA3-G230MT
KA-MT 4	K4/16DA3-G230M	K4/16DA3-G230MT

CDAS Medium Flow Heatless Adsorption Dryers

Dryer Performance

Dryer Models	Dewpoint (Standard)		ISO8573-1:2010 Classification (Standard)	Dewpoint (Option 1)		ISO8573-1:2010 Classification (Option 1)	Dewpoint (Option 2)		ISO8573-1:2010 Classification (Option 2)
	°C	°F		°C	°F		°C	°F	
CDAS HL	-40	-40	Class 2.2.2	-70	-100	Class 2.1.2	-20	-4	Class 2.3.2

ISO8573-1 Classifications when used with OIL-X pre / post filtration

Technical Data

Dryer Models	Minimum Operating Pressure		Maximum Operating Pressure		Minimum Operating Temperature		Maximum Operating Temperature		Maximum Ambient Temperature		Electrical Supply (Standard)	Electrical Supply (Optional)	Thread Type	Noise Level dB(A)
	bar g	psi g	bar g	psi g	°C	°F	°C	°F	°C	°F				
CDAS HL 050 - 085	4	58	16	232	5	41	50	122	55	131	85 - 265V 1ph 50/60Hz	24V DC	BSPP or NPT	<75

Flow Rates

Model	Pipe Size BSPP or NPT	Inlet Flow Rate			
		L/s	m ³ /min	m ³ /hr	cfm
CDAS HL 050	½"	15	0.92	55	32
CDAS HL 055	½"	19	1.17	70	41
CDAS HL 060	½"	25	1.50	90	53
CDAS HL 065	½"	31	1.84	110	65
CDAS HL 070	¾"	42	2.51	150	88
CDAS HL 075	1"	51	3.09	185	109
CDAS HL 080	1"	61	3.67	220	129
CDAS HL 085	1½"	83	5.01	300	177

Stated flows are for operation at 7 bar (g) (102 psi g) with reference to 20°C, 1 bar (a), 0% relative water vapour pressure. For flows at other pressures, apply the correction factors shown below.

Product Selection & Correction Factors

For correct operation, compressed air dryers must be sized using for the maximum (summer) inlet temperature, maximum (summer) ambient temperature, minimum inlet pressure, required outlet dewpoint and maximum flow rate of the installation.

To select a dryer, first calculate the MDC (Minimum Drying Capacity) using the formula below then select a dryer from the flow rate table above with a flow rate equal to or above the MDC.

Minimum Drying Capacity = System Flow x CFMIT x CFMAT x CFMIP x CFOD

CFMIT - Correction Factor Maximum Inlet Temperature

Maximum Inlet Temperature	°C	25	30	35	40	45	50
	°F	77	86	95	104	113	122
Correction Factor		1.00	1.00	1.00	1.04	1.14	1.37

CFMAT - Correction Factor Maximum Ambient Temperature

Maximum Ambient Temperature	°C	25	30	35	40	45	50
	°F	77	86	95	104	113	122
Correction Factor		1.00	1.00	1.00	1.00	1.00	1.00

CFMIP - Correction Factor Minimum Inlet Pressure

Minimum Inlet Pressure	bar g	4	5	6	7	8	9	10	11	12	13	14	15	16
	psi g	58	73	87	100	116	131	145	160	174	189	203	218	232
Correction Factor		1.60	1.33	1.14	1.00	0.89	0.80	0.73	0.67	0.62	0.57	0.53	0.50	0.47

CFOD - Correction Factor Outlet Dewpoint

Outlet Dewpoint	°C	-20	-40	-70
	°F	-4	-40	-100
Correction Factor		0.91	1.00	2.00

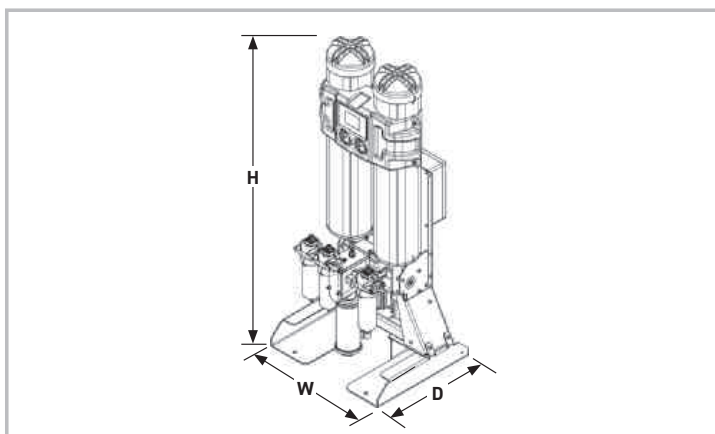

Weights & Dimensions

Model	Dimensions						Weight	
	Height (H)		Width (W)		Depth (D)			
	mm	ins	mm	ins	mm	ins	kg	lbs
CDAS HL 050	1133	45	559	22	490	19	76	168
CDAS HL 055	1313	52	559	22	490	19	84	185
CDAS HL 060	1510	59	559	22	490	19	93	205
CDAS HL 065	1660	65	559	22	490	19	100	220
CDAS HL 070	2020	80	559	22	490	19	120	265
CDAS HL 075	1595	63	559	22	682	27	165	364
CDAS HL 080	1745	69	559	22	682	27	180	397
CDAS HL 085	2105	83	559	22	682	27	210	463

Included Filtration

Model	Pipe Size BSPP or NPT	Dryer Inlet		Dryer Outlet		
		General Purpose Pre-filter	High Efficiency Filter	Oil Vapour Reduction Filter	General Purpose Dry Particulate Filter	High Efficiency Dry Particulate Filter
CDAS HL 050	½"	AOP015C	AAP015C	-	AOP015C	-
CDAS HL 055	½"	AOP015C	AAP015C	-	AOP015C	-
CDAS HL 060	½"	AOP020C	AAP020C	-	AOP020C	-
CDAS HL 065	½"	AOP020C	AAP020C	-	AOP020C	-
CDAS HL 070	¾"	AOP025D	AAP025D	-	AOP025D	-
CDAS HL 075	1"	AOP025E	AAP025E	-	AOP025E	-
CDAS HL 080	1"	AOP025E	AAP025E	-	AOP025E	-
CDAS HL 085	1½"	AOP030G	AAP030G	-	AOP030G	-

Parker Catalogue Numbers

Model	Catalogue Number -20°C PDP / -40°C PDP BSPP	Catalogue Number -70°C PDP BSPP	Catalogue Number -20°C PDP / -40°C PDP NPT	Catalogue Number -70°C PDP NPT
CDAS HL 50	CDASHL050-40G16AE	CDASHL050-70G16AE	CDASHL050-40N16AE	CDASHL050-70N16AE
CDAS HL 55	CDASHL055-40G16AE	CDASHL055-70G16AE	CDASHL055-40N16AE	CDASHL055-70N16AE
CDAS HL 60	CDASHL060-40G16AE	CDASHL060-70G16AE	CDASHL060-40N16AE	CDASHL060-70N16AE
CDAS HL 65	CDASHL065-40G16AE	CDASHL065-70G16AE	CDASHL065-40N16AE	CDASHL065-70N16AE
CDAS HL 70	CDASHL070-40G16AE	CDASHL070-70G16AE	CDASHL070-40N16AE	CDASHL070-70N16AE
CDAS HL 75	CDASHL075-40G16AE	CDASHL075-70G16AE	CDASHL075-40N16AE	CDASHL075-70N16AE
CDAS HL 80	CDASHL080-40G16AE	CDASHL080-70G16AE	CDASHL080-40N16AE	CDASHL080-70N16AE
CDAS HL 85	CDASHL085-40G16AE	CDASHL085-70G16AE	CDASHL085-40N16AE	CDASHL085-70N16AE

OFAS Medium Flow Heatless Adsorption Dryers

Dryer Performance

Dryer Models	Dewpoint (Standard)		ISO8573-1:2010 Classification (Standard)	Dewpoint (Option 1)		ISO8573-1:2010 Classification (Option 1)	Dewpoint (Option 2)		ISO8573-1:2010 Classification (Option 2)
	°C	°F		°C	°F		°C	°F	
OFAS HL	-40	-40	Class 2.2.0	-70	-100	Class 2.1.0	-20	-4	Class 2.3.0

ISO8573-1 Classifications when used with OIL-X pre / post filtration

Technical Data

Dryer Models	Minimum Operating Pressure		Maximum Operating Pressure		Minimum Operating Temperature		Maximum Operating Temperature		Maximum Ambient Temperature		Electrical Supply (Standard)	Electrical Supply (Optional)	Thread Type	Noise Level dB(A)
	bar g	psi g	bar g	psi g	°C	°F	°C	°F	°C	°F				
OFAS HL 050 - 085	4	58	16	232	5	41	50	122	55	131	85 - 265V 1ph 50/60Hz	24V DC	BSPP or NPT	<75

Flow Rates

Model	Pipe Size BSPP or NPT	Inlet Flow Rate			
		L/s	m³/min	m³/hr	cfm
OFAS HL 050	½"	15	0.92	55	32
OFAS HL 055	½"	19	1.17	70	41
OFAS HL 060	½"	25	1.50	90	53
OFAS HL 065	½"	31	1.84	110	65
OFAS HL 070	¾"	42	2.51	150	88
OFAS HL 075	1"	51	3.09	185	109
OFAS HL 080	1"	61	3.67	220	129
OFAS HL 085	1½"	83	5.01	300	177

Stated flows are for operation at 7 bar (g) (102 psi g) with reference to 20°C, 1 bar (a), 0% relative water vapour pressure. For flows at other pressures, apply the correction factors shown below.

Product Selection & Correction Factors

For correct operation, compressed air dryers must be sized using for the maximum (summer) inlet temperature, maximum (summer) ambient temperature, minimum inlet pressure, required outlet dewpoint and maximum flow rate of the installation.

To select a dryer, first calculate the MDC (Minimum Drying Capacity) using the formula below then select a dryer from the flow rate table above with a flow rate equal to or above the MDC.

Minimum Drying Capacity = System Flow x CFMIT x CFMAT x CFMIP x CFOD

CFMIT - Correction Factor Maximum Inlet Temperature

Maximum Inlet Temperature	°C	25	30	35	40	45	50
	°F	77	86	95	104	113	122
Correction Factor		1.00	1.00	1.00	1.04	1.14	1.37

CFMAT - Correction Factor Maximum Ambient Temperature

Maximum Ambient Temperature	°C	25	30	35	40	45	50
	°F	77	86	95	104	113	122
Correction Factor		1.00	1.00	1.00	1.00	1.00	1.00

CFMIP - Correction Factor Minimum Inlet Pressure

Minimum Inlet Pressure	bar g	4	5	6	7	8	9	10	11	12	13	14	15	16
	psi g	58	73	87	100	116	131	145	160	174	189	203	218	232
Correction Factor		1.60	1.33	1.14	1.00	0.89	0.80	0.73	0.67	0.62	0.57	0.53	0.50	0.47

CFOD - Correction Factor Outlet Dewpoint

Outlet Dewpoint	°C	-20	-40	-70
	°F	-4	-40	-100
Correction Factor		0.91	1.00	2.00

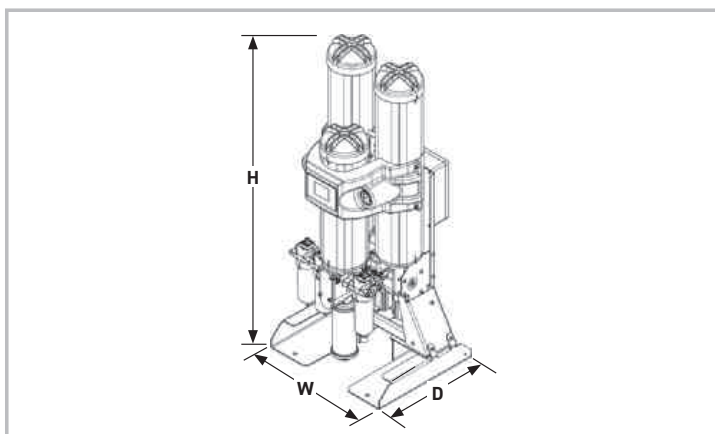

Weights & Dimensions

Model	Dimensions						Weight	
	Height (H)		Width (W)		Depth (D)			
	mm	ins	mm	ins	mm	ins	kg	lbs
OFAS HL 050	1133	45	559	22	512	20.2	90	198
OFAS HL 055	1313	52	559	22	512	20.2	97	214
OFAS HL 060	1510	59	559	22	496	19.5	106	234
OFAS HL 065	1660	65	559	22	496	19.5	112	247
OFAS HL 070	2020	80	559	22	496	19.5	132	291
OFAS HL 075	1595	63	559	22	682	27	184	406
OFAS HL 080	1745	69	559	22	682	27	196	432
OFAS HL 085	2105	83	559	22	682	27	232	511

Included Filtration

Model	Pipe Size BSPP or NPT	Dryer Inlet		Dryer Outlet		
		General Purpose Pre-filter	High Efficiency Filter	Oil Vapour Reduction Filter	General Purpose Dry Particulate Filter	High Efficiency Dry Particulate Filter
OFAS HL 050	½"	AOP015C	AAP015C	Included	AOP015C	-
OFAS HL 055	½"	AOP015C	AAP015C	Included	AOP015C	-
OFAS HL 060	½"	AOP020C	AAP020C	Included	AOP020C	-
OFAS HL 065	½"	AOP020C	AAP020C	Included	AOP020C	-
OFAS HL 070	¾"	AOP025D	AAP025D	Included	AOP025D	-
OFAS HL 075	1"	AOP025E	AAP025E	Included	AOP025E	-
OFAS HL 080	1"	AOP025E	AAP025E	Included	AOP025E	-
OFAS HL 085	1½"	AOP030G	AAP030G	Included	AOP030G	-

Parker Catalogue Numbers

Model	Catalogue Number -20°C PDP / -40°C PDP BSPP	Catalogue Number -70°C PDP BSPP	Catalogue Number -20°C PDP / -40°C PDP NPT	Catalogue Number -70°C PDP NPT
OFAS HL 50	OFASHL050-40G16AE	OFASHL050-70G16AE	OFASHL050-40N16AE	OFASHL050-70N16AE
OFAS HL 55	OFASHL055-40G16AE	OFASHL055-70G16AE	OFASHL055-40N16AE	OFASHL055-70N16AE
OFAS HL 60	OFASHL060-40G16AE	OFASHL060-70G16AE	OFASHL060-40N16AE	OFASHL060-70N16AE
OFAS HL 65	OFASHL065-40G16AE	OFASHL065-70G16AE	OFASHL065-40N16AE	OFASHL065-70N16AE
OFAS HL 70	OFASHL070-40G16AE	OFASHL070-70G16AE	OFASHL070-40N16AE	OFASHL070-70N16AE
OFAS HL 75	OFASHL075-40G16AE	OFASHL075-70G16AE	OFASHL075-40N16AE	OFASHL075-70N16AE
OFAS HL 80	OFASHL080-40G16AE	OFASHL080-70G16AE	OFASHL080-40N16AE	OFASHL080-70N16AE
OFAS HL 85	OFASHL085-40G16AE	OFASHL085-70G16AE	OFASHL085-40N16AE	OFASHL085-70N16AE

FBP Medium Flow Heatless Adsorption Dryers

Dryer Performance

Dryer Models	Dewpoint (Standard)		ISO8573-1:2010 Classification (Standard)	Dewpoint (Option 1)		ISO8573-1:2010 Classification (Option 1)	Dewpoint (Option 2)		ISO8573-1:2010 Classification (Option 2)
	°C	°F		°C	°F		°C	°F	
FBP HL	-40	-40	Class 2.2.0	-70	-100	Class 2.1.0	-20	-4	Class 2.3.0

ISO8573-1 Classifications when used with OIL-X pre / post filtration

Technical Data

Dryer Models	Minimum Operating Pressure		Maximum Operating Pressure		Minimum Operating Temperature		Maximum Operating Temperature		Maximum Ambient Temperature		Electrical Supply (Standard)	Electrical Supply (Optional)	Thread Type	Noise Level dB(A)
	bar g	psi g	bar g	psi g	°C	°F	°C	°F	°C	°F				
FBP HL 050 - 085	4	58	16	232	5	41	50	122	55	131	85 - 265V 1ph 50/60Hz	24V DC	BSPB or NPT	<75

Flow Rates

Model	Pipe Size BSPB or NPT	Inlet Flow Rate			
		L/s	m ³ /min	m ³ /hr	cfm
FBP HL 050	½"	15	0.92	55	32
FBP HL 055	½"	19	1.17	70	41
FBP HL 060	½"	25	1.50	90	53
FBP HL 065	½"	31	1.84	110	65
FBP HL 070	¾"	42	2.51	150	88
FBP HL 075	1"	51	3.09	185	109
FBP HL 080	1"	61	3.67	220	129
FBP HL 085	1½"	83	5.01	300	177

Stated flows are for operation at 7 bar (g) (102 psi g) with reference to 20°C, 1 bar (a), 0% relative water vapour pressure. For flows at other pressures, apply the correction factors shown below.

Product Selection & Correction Factors

For correct operation, compressed air dryers must be sized using for the maximum (summer) inlet temperature, maximum (summer) ambient temperature, minimum inlet pressure, required outlet dewpoint and maximum flow rate of the installation.

To select a dryer, first calculate the MDC (Minimum Drying Capacity) using the formula below then select a dryer from the flow rate table above with a flow rate equal to or above the MDC.

$$\text{Minimum Drying Capacity} = \text{System Flow} \times \text{CFMIT} \times \text{CFMAT} \times \text{CFMIP} \times \text{CFOD}$$

CFMIT - Correction Factor Maximum Inlet Temperature

Maximum Inlet Temperature	°C	25	30	35	40	45	50
	°F	77	86	95	104	113	122
Correction Factor		1.00	1.00	1.00	1.04	1.14	1.37

CFMAT - Correction Factor Maximum Ambient Temperature

Maximum Ambient Temperature	°C	25	30	35	40	45	50
	°F	77	86	95	104	113	122
Correction Factor		1.00	1.00	1.00	1.00	1.00	1.00

CFMIP - Correction Factor Minimum Inlet Pressure

Minimum Inlet Pressure	bar g	4	5	6	7	8	9	10	11	12	13	14	15	16
	psi g	58	73	87	100	116	131	145	160	174	189	203	218	232
Correction Factor		1.60	1.33	1.14	1.00	0.89	0.80	0.73	0.67	0.62	0.57	0.53	0.50	0.47

CFOD - Correction Factor Outlet Dewpoint

Outlet Dewpoint	°C	-20	-40	-70
	°F	-4	-40	-100
Correction Factor		0.91	1.00	2.00

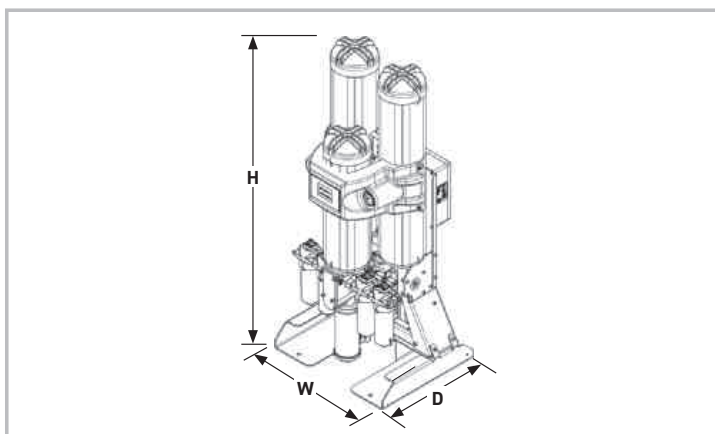

Weights & Dimensions

Model	Dimensions						Weight	
	Height (H)		Width (W)		Depth (D)			
	mm	ins	mm	ins	mm	ins	kg	lbs
FBP HL 050	1133	45	559	22	512	20.2	90	198
FBP HL 055	1313	52	559	22	512	20.2	97	214
FBP HL 060	1510	59	559	22	496	19.5	106	234
FBP HL 065	1660	65	559	22	496	19.5	112	247
FBP HL 070	2020	80	630	24.8	496	19.5	132	291
FBP HL 075	1595	63	630	24.8	682	27	184	406
FBP HL 080	1745	69	630	24.8	682	27	196	432
FBP HL 085	2105	83	630	24.8	682	27	232	511

Included Filtration

Model	Pipe Size BSPP or NPT	Dryer Inlet		Oil Vapour Reduction Filter	Dryer Outlet	
		General Purpose Pre-filter	High Efficiency Filter		General Purpose Dry Particulate Filter	High Efficiency Dry Particulate Filter
FBP HL 050	½"	AOP015C	AAP015C	Included	AOP015C	AAP015C
FBP HL 055	½"	AOP015C	AAP015C	Included	AOP015C	AAP015C
FBP HL 060	½"	AOP020C	AAP020C	Included	AOP020C	AAP020C
FBP HL 065	½"	AOP020C	AAP020C	Included	AOP020C	AAP020C
FBP HL 070	¾"	AOP025D	AAP025D	Included	AOP025D	AAP025D
FBP HL 075	1"	AOP025E	AAP025E	Included	AOP025E	AAP025E
FBP HL 080	1"	AOP025E	AAP025E	Included	AOP025E	AAP025E
FBP HL 085	1½"	AOP030G	AAP030G	Included	AOP030G	AAP030G

Parker Catalogue Numbers

Model	Catalogue Number -20°C PDP / -40°C PDP BSPP	Catalogue Number -70°C PDP BSPP
FBP HL 050	FBPHL050-40G16AE	FBPHL050-70G16AE
FBP HL 055	FBPHL055-40G16AE	FBPHL055-70G16AE
FBP HL 060	FBPHL060-40G16AE	FBPHL060-70G16AE
FBP HL 065	FBPHL065-40G16AE	FBPHL065-70G16AE
FBP HL 070	FBPHL070-40G16AE	FBPHL070-70G16AE
FBP HL 075	FBPHL075-40G16AE	FBPHL075-70G16AE
FBP HL 080	FBPHL080-40G16AE	FBPHL080-70G16AE
FBP HL 085	FBPHL085-40G16AE	FBPHL085-70G16AE

CDAS HL ATEX Medium Flow Heatless Adsorption Dryers

Dryer Performance

Dryer Models	Dewpoint (Standard)		ISO8573-1:2010 Classification (Standard)
	°C	°F	
CDAS HL ATEX	-40	-40	Class 2.2.2

ISO8573-1 Classifications when used with OIL-X pre / post filtration

Technical Data

Dryer Models	Minimum Operating Pressure		Maximum Operating Pressure		Minimum Operating Temperature		Maximum Operating Temperature		Maximum Ambient Temperature		Electrical Supply	Thread Type	Noise Level dB(A)
	bar g	psi g	bar g	psi g	°C	°F	°C	°F	°C	°F			
CDAS HL ATEX	4	58	16	232	5	41	50	122	55	131	Not Applicable - Fully Pneumatic Operation	BSPP or NPT	<75

Flow Rates

Model	Pipe Size BSPP or NPT	Inlet Flow Rate			
		L/s	m³/min	m³/hr	cfm
CDAS HL 050 ATEX	½"	15	0.92	55	32
CDAS HL 055 ATEX	½"	19	1.17	70	41
CDAS HL 060 ATEX	½"	25	1.50	90	53
CDAS HL 065 ATEX	½"	31	1.84	110	65
CDAS HL 070 ATEX	¾"	42	2.51	150	88
CDAS HL 075 ATEX	1"	51	3.09	185	109
CDAS HL 080 ATEX	1"	61	3.67	220	129
CDAS HL 085 ATEX	1½"	83	5.01	300	177

Stated flows are for operation at 7 bar (g) (102 psi g) with reference to 20°C, 1 bar (a), 0% relative water vapour pressure. For flows at other pressures, apply the correction factors shown below.

Product Selection & Correction Factors

For correct operation, compressed air dryers must be sized using for the maximum (summer) inlet temperature, maximum (summer) ambient temperature, minimum inlet pressure, required outlet dewpoint and maximum flow rate of the installation.

To select a dryer, first calculate the MDC (Minimum Drying Capacity) using the formula below then select a dryer from the flow rate table above with a flow rate equal to or above the MDC.

Minimum Drying Capacity = System Flow x CFMIT x CFMAT x CFMIP x CFOD

CFMIT - Correction Factor Maximum Inlet Temperature

Maximum Inlet Temperature	°C	25	30	35	40	45	50
	°F	77	86	95	104	113	122
Correction Factor		1.00	1.00	1.00	1.04	1.14	1.37

CFMAT - Correction Factor Maximum Ambient Temperature

Maximum Ambient Temperature	°C	25	30	35	40	45	50
	°F	77	86	95	104	113	122
Correction Factor		1.00	1.00	1.00	1.00	1.00	1.00

CFMIP - Correction Factor Minimum Inlet Pressure

Minimum Inlet Pressure	bar g	4	5	6	7	8	9	10	11	12	13	14	15	16
	psi g	58	73	87	100	116	131	145	160	174	189	203	218	232
Correction Factor		1.60	1.33	1.14	1.00	0.89	0.80	0.73	0.67	0.62	0.57	0.53	0.50	0.47

CFOD - Correction Factor Outlet Dewpoint

Outlet Dewpoint	°C	-20	-40	-70
	°F	-4	-40	-100
Correction Factor		0.91	1.00	2.00

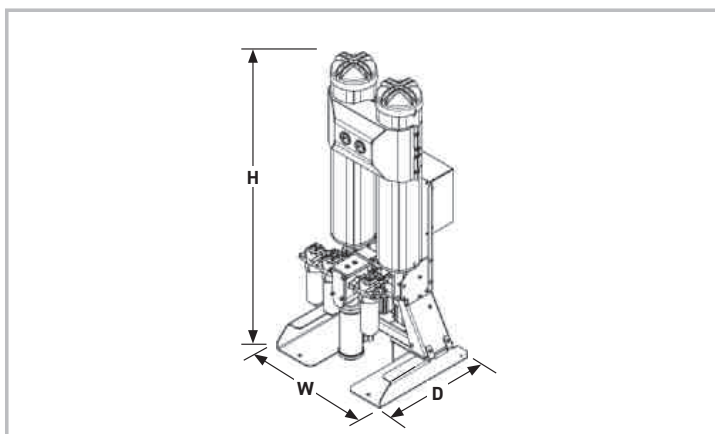

Weights & Dimensions

Model	Dimensions						Weight	
	Height (H)		Width (W)		Depth (D)			
	mm	ins	mm	ins	mm	ins	kg	lbs
CDAS HL 050 ATEX	1133	45	559	22	490	19	76	168
CDAS HL 055 ATEX	1313	52	559	22	490	19	84	185
CDAS HL 060 ATEX	1510	59	559	22	490	19	93	205
CDAS HL 065 ATEX	1660	65	559	22	490	19	100	220
CDAS HL 070 ATEX	2020	80	559	22	490	19	120	265
CDAS HL 075 ATEX	1595	63	559	22	682	27	165	364
CDAS HL 080 ATEX	1745	69	559	22	682	27	180	397
CDAS HL 085 ATEX	2105	83	559	22	682	27	210	463

Included Filtration

Model	Pipe Size BSP or NPT	Dryer Inlet		Dryer Outlet		
		General Purpose Pre-filter	High Efficiency Filter	Oil Vapour Reduction Filter	General Purpose Dry Particulate Filter	High Efficiency Dry Particulate Filter
CDAS HL 050 ATEX	½"	AOP015C	AAP015C	-	AOP015C	-
CDAS HL 055 ATEX	½"	AOP015C	AAP015C	-	AOP015C	-
CDAS HL 060 ATEX	½"	AOP020C	AAP020C	-	AOP020C	-
CDAS HL 065 ATEX	½"	AOP020C	AAP020C	-	AOP020C	-
CDAS HL 070 ATEX	¾"	AOP025D	AAP025D	-	AOP025D	-
CDAS HL 075 ATEX	1"	AOP025E	AAP025E	-	AOP025E	-
CDAS HL 080 ATEX	1"	AOP025E	AAP025E	-	AOP025E	-
CDAS HL 085 ATEX	1½"	AOP030G	AAP030G	-	AOP030G	-

Parker Catalogue Numbers

Model	Catalogue Number -20°C PDP / -40°C PDP BSPP	Catalogue Number -70°C PDP BSPP
CDAS HL 050 ATEX	CDASHL050-40G16PP	CDASHL050-70G16PP
CDAS HL 055 ATEX	CDASHL055-40G16PP	CDASHL055-70G16PP
CDAS HL 060 ATEX	CDASHL060-40G16PP	CDASHL060-70G16PP
CDAS HL 065 ATEX	CDASHL065-40G16PP	CDASHL065-70G16PP
CDAS HL 070 ATEX	CDASHL070-40G16PP	CDASHL070-70G16PP
CDAS HL 075 ATEX	CDASHL075-40G16PP	CDASHL075-70G16PP
CDAS HL 080 ATEX	CDASHL080-40G16PP	CDASHL080-70G16PP
CDAS HL 085 ATEX	CDASHL085-40G16PP	CDASHL085-70G16PP

MX Large Flow Heatless Adsorption Dryers

Dryer Performance

Dryer Models	Dewpoint (Standard)		ISO8573-1:2010 Classification (Standard)	Dewpoint (Option 1)		ISO8573-1:2010 Classification (Option 1)	Dewpoint (Option 2)		ISO8573-1:2010 Classification (Option 2)
	°C	°F		°C	°F		°C	°F	
MXS DS	-40	-40	Class 2.2.2	-70	-100	Class 2.1.2	-20	-4	Class 2.3.2

ISO8573-1 Classifications when used with OIL-X pre / post filtration

Technical Data

Dryer Models	Minimum Operating Pressure		Maximum Operating Pressure		Minimum Operating Temperature		Maximum Operating Temperature		Maximum Ambient Temperature		Electrical Supply (Standard)	Electrical Supply (Optional)	Thread Type	Noise Level dB(A)
	bar g	psi g	bar g	psi g	°C	°F	°C	°F	°C	°F				
MXS102CDS - MXS108DS	4	58	13	190	5	41	50	122	55	131	85 - 265V 1ph 50/60Hz	N/A	BSPP or NPT	<75

Flow Rates (Single Banks)

Model	Pipe Size	Inlet Flow Rate			
		L/s	m³/min	m³/hr	cfm
MXS102CDS	2"	113	6.81	408	240
MXS103CDS	2"	170	10.22	612	360
MXS103DS	2"	213	12.75	765	450
MXS104DS	2½"	283	17	1020	600
MXS105DS	2½"	354	21	1275	750
MXS106DS	2½"	425	26	1530	900
MXS107DS	2½"	496	30	1785	1050
MXS108DS	2½"	567	34	2040	1200

Flow Rates (Multi-Banked)

Model	Pipe Size	Inlet Flow Rate			
		L/s	m³/min	m³/hr	cfm
2 x MXS105DS	2½"	708	43	2550	1500
2 x MXS106DS	2½"	850	51	3060	1800
2 x MXS107DS	2½"	992	60	3570	2100
2 x MXS108DS	2½"	1133	68	4080	2400
3 x MXS106DS	2½"	1275	77	4590	2700
3 x MXS107DS	2½"	1488	89	5355	3150
3 x MXS108DS	2½"	1700	102	6120	3600

For Higher Flow Capacities - Contact Parker

Stated flows are for operation at 7 bar (g) (102 psi g) with reference to 20°C, 1 bar (a), 0% relative water vapour pressure. For flows at other pressures, apply the correction factors shown below.

Product Selection & Correction Factors

For correct operation, compressed air dryers must be sized using for the maximum (summer) inlet temperature, maximum (summer) ambient temperature, minimum inlet pressure, required outlet dewpoint and maximum flow rate of the installation.

To select a dryer, first calculate the MDC (Minimum Drying Capacity) using the formula below then select a dryer from the flow rate table above with a flow rate equal to or above the MDC.

Minimum Drying Capacity = System Flow x CFMIT x CFMAT x CFMIP x CFOD

CFMIT - Correction Factor Maximum Inlet Temperature

Maximum Inlet Temperature	°C	25	30	35	40	45	50
	°F	77	86	95	104	113	122
Correction Factor		1.00	1.00	1.00	1.04	1.14	1.37

CFMAT - Correction Factor Maximum Ambient Temperature

Maximum Ambient Temperature	°C	25	30	35	40	45	50
	°F	77	86	95	104	113	122
Correction Factor		1.00	1.00	1.00	1.00	1.00	1.00

CFMIP - Correction Factor Minimum Inlet Pressure

Minimum Inlet Pressure	bar g	4	5	6	7	8	9	10	11	12	13
	psi g	58	73	87	100	116	131	145	160	174	189
Correction Factor		1.60	1.33	1.14	1.00	0.89	0.80	0.73	0.67	0.62	0.57

CFOD - Correction Factor Outlet Dewpoint

Outlet Dewpoint	°C	-20	-40	-70
	°F	-4	-40	-100
Correction Factor		0.91	1.00	1.43

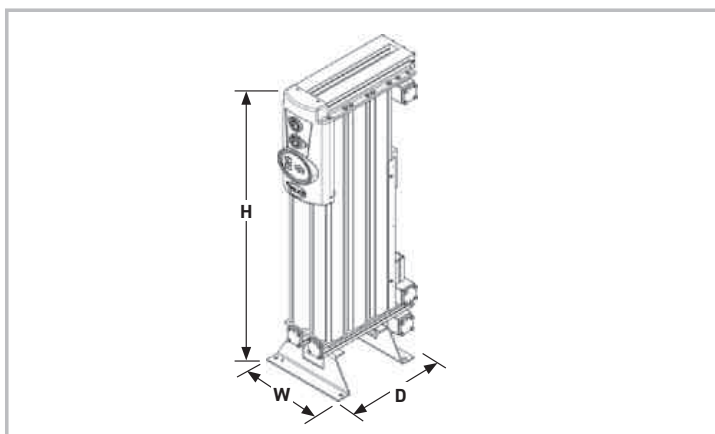

Weights & Dimensions

Model	Dimensions						Weight	
	Height (H)		Width (W)		Depth (D)			
	mm	ins	mm	ins	mm	ins	kg	lbs
MXS102CDS	1647	64.8	687	27.0	550	21.7	235	518
MXS103CDS	1647	64.8	856	33.7	550	21.7	316	696
MXS103DS	1892	74.5	856	33.7	550	21.7	355	782
MXS104DS	1892	74.5	1025	40.3	550	21.7	450	992
MXS105DS	1892	74.5	1194	47.0	550	21.7	543	1197
MXS106DS	1892	74.5	1363	53.6	550	21.7	637	1404
MXS107DS	1892	74.5	1532	60.3	550	21.7	731	1611
MXS108DS	1892	74.5	1701	67.0	550	21.7	825	1818

Recommended Filtration

Model	Pipe Size BSPP or NPT	Dryer Inlet		Oil Vapour Reduction Filter	Dryer Outlet	
		General Purpose Pre-filter	High Efficiency Filter		General Purpose Dry Particulate Filter	High Efficiency Dry Particulate Filter
MXS102CDS	2"	AOP040H	AAP040H	Technically 'Oil Free Air' to ISO8573-1:2010 Class 0 (<0.003 mg/m ³) for total oil can be easily achieved by selecting an optional OIL-X OVR grade filter.	AOP040H	-
MXS103CDS	2"	AOP040H	AAP040H		AOP040H	-
MXS103DS	2"	AOP040H	AAP040H		AOP040H	-
MXS104DS	2½"	AOP045I	AAP045I		AOP045I	-
MXS105DS	2½"	AOP050I	AAP050I		AOP050I	-
MXS106DS	2½"	AOP050I	AAP050I		AOP050I	-
MXS107DS	2½"	AOP055I	AAP055I		AOP055I	-
MXS108DS	2½"	AOP055I	AAP055I		AOP055I	-

Parker Catalogue Numbers

Model	Catalogue Number -20°C PDP / -40°C PDP	Catalogue Number -70°C PDP
MXS102CDS	MXS102CDS-40BP	MXS102CDS-70BP
MXS103CDS	MXS103CDS-40BP	MXS103CDS-70BP
MXS103DS	MXS103DS-40BP	MXS103DS-70BP
MXS104DS	MXS104DS-40BP	MXS104DS-70BP
MXS105DS	MXS105DS-40BP	MXS105DS-70BP
MXS106DS	MXS106DS-40BP	MXS106DS-70BP
MXS107DS	MXS107DS-40BP	MXS107DS-70BP
MXS108DS	MXS108DS-40BP	MXS108DS-70BP

**Dryer catalogue number does not include filtration -
Please order filters separately**

Important Notes Regarding the Ordering of MXS dryers

Please note that when ordering MXS heatless dryers, the following items must also be ordered separately.

- Dryer Model
- Inlet / Outlet Flange kit (BSPP or NPT)
- Pre / Post Filtration (Grades A0 / AA / A0)
- FCD (Flow Control Device) - only required for multi-bank installations
- QRV - Part Number 608203833 for operation 9 bar g

MX ATEX Pneumatic Heatless Adsorption Dryers

Dryer Performance

Dryer Models	Dewpoint (Standard)		ISO8573-1:2010 Classification (Standard)	Dewpoint (Option 1)		ISO8573-1:2010 Classification (Option 1)	Dewpoint (Option 2)		ISO8573-1:2010 Classification (Option 2)
	°C	°F		°C	°F		°C	°F	
MXS DS	-40	-40	Class 2.2.2	-70	-100	Class 2.1.2	-20	-4	Class 2.3.2

ISO8573-1 Classifications when used with OIL-X pre / post filtration

Technical Data

Dryer Models	Minimum Operating Pressure		Maximum Operating Pressure		Minimum Operating Temperature		Maximum Operating Temperature		Maximum Ambient Temperature		Electrical Supply (Standard)	Electrical Supply (Optional)	Thread Type	Noise Level dB(A)
	bar g	psi g	bar g	psi g	°C	°F	°C	°F	°C	°F				
MXS102CDS - MXS108DS	4	58	13	190	5	41	50	122	55	131	Not Applicable - Fully Pneumatic Operation		BSPP	<75

Flow Rates

Model	Pipe Size	Inlet Flow Rate			
		L/s	m³/min	m³/hr	cfm
MXP102c	2"	113	6.81	408	240
MXP103c	2"	170	10.22	612	360
MXP103	2"	213	12.75	765	450
MXP104	2½"	283	17	1020	600
MXP105	2½"	354	21	1275	750
MXP106	2½"	425	26	1530	900
MXP107	2½"	496	30	1785	1050
MXP108	2½"	567	34	2040	1200

Stated flows are for operation at 7 bar (g) (102 psi g) with reference to 20°C, 1 bar (a), 0% relative water vapour pressure. For flows at other pressures, apply the correction factors shown below.

Product Selection & Correction Factors

For correct operation, compressed air dryers must be sized using for the maximum (summer) inlet temperature, maximum (summer) ambient temperature, minimum inlet pressure, required outlet dewpoint and maximum flow rate of the installation.

To select a dryer, first calculate the MDC (Minimum Drying Capacity) using the formula below then select a dryer from the flow rate table above with a flow rate equal to or above the MDC.

$$\text{Minimum Drying Capacity} = \text{System Flow} \times \text{CFMIT} \times \text{CFMAT} \times \text{CFMIP} \times \text{CFOD}$$

CFMIT - Correction Factor Maximum Inlet Temperature

Maximum Inlet Temperature	°C	25	30	35	40	45	50
	°F	77	86	95	104	113	122
Correction Factor		1.00	1.00	1.00	1.04	1.14	1.37

CFMAT - Correction Factor Maximum Ambient Temperature

Maximum Ambient Temperature	°C	25	30	35	40	45	50
	°F	77	86	95	104	113	122
Correction Factor		1.00	1.00	1.00	1.00	1.00	1.00

CFMIP - Correction Factor Minimum Inlet Pressure

Minimum Inlet Pressure	bar g	4	5	6	7	8	9	10	11	12	13
	psi g	58	73	87	100	116	131	145	160	174	189
Correction Factor		1.60	1.33	1.14	1.00	0.89	0.80	0.73	0.67	0.62	0.57

CFOD - Correction Factor Outlet Dewpoint

Outlet Dewpoint	°C	-20	-40	-70
	°F	-4	-40	-100
Correction Factor		0.91	1.00	1.43

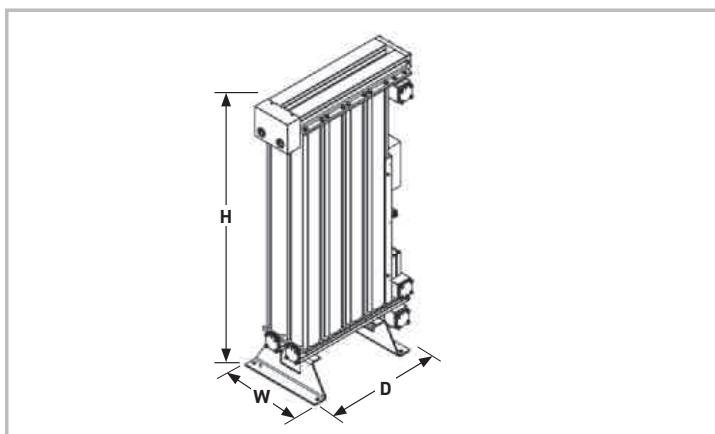

Weights & Dimensions

Model	Dimensions						Weight	
	Height (H)		Width (W)		Depth (D)			
	mm	ins	mm	ins	mm	ins	kg	lbs
MX102C	1647	64.8	687	27.0	550	21.7	235	518
MX103C	1647	64.8	856	33.7	550	21.7	316	696
MX103	1892	74.5	856	33.7	550	21.7	355	782
MX104	1892	74.5	1025	40.3	550	21.7	450	992
MX105	1892	74.5	1194	47.0	550	21.7	543	1197
MX106	1892	74.5	1363	53.6	550	21.7	637	1404
MX107	1892	74.5	1532	60.3	550	21.7	731	1611
MX108	1892	74.5	1701	67.0	550	21.7	825	1818

Recommended Filtration

Model	Pipe Size BSPP	Dryer Inlet		Dryer Outlet		
		General Purpose Pre-filter	High Efficiency Filter	Oil Vapour Reduction Filter	General Purpose Dry Particulate Filter	High Efficiency Dry Particulate Filter
MXP102c	2"	AOP040HGFX	AAP040HGFX	-	AOP040HGFX	-
MXP103c	2"	AOP040HGFX	AAP040HGFX	-	AOP040HGFX	-
MXP103	2"	AOP040HGFX	AAP040HGFX	-	AOP040HGFX	-
MXP104	2½"	AOP045IGFX	AAP045IGFX	-	AOP045IGFX	-
MXP105	2½"	AOP050IGFX	AAP050IGFX	-	AOP050IGFX	-
MXP106	2½"	AOP050IGFX	AAP050IGFX	-	AOP050IGFX	-
MXP107	2½"	AOP055IGFX	AAP055IGFX	-	AOP055IGFX	-
MXP108	2½"	AOP055IGFX	AAP055IGFX	-	AOP055IGFX	-

Parker Catalogue Numbers

Model	Catalogue Number -20°C PDP / -40°C PDP	Catalogue Number -70°C PDP
MXP102c	MXP102C-40-ATEX	MXP102C-70-ATEX
MXP103c	MXP103C-40-ATEX	MXP103C-70-ATEX
MXP103	MXP103-40-ATEX	MXP103-70-ATEX
MXP104	MXP104-40-ATEX	MXP104-70-ATEX
MXP105	MXP105-40-ATEX	MXP105-70-ATEX
MXP106	MXP106-40-ATEX	MXP106-70-ATEX
MXP107	MXP107-40-ATEX	MXP107-70-ATEX
MXP108	MXP108-40-ATEX	MXP108-70-ATEX

Dryer catalogue number does not include filtration -
Please order filters separately

Important Notes Regarding the Ordering of MXS dryers

Please note that when ordering MXP heatless dryers, the following items must also be ordered separately.

- Dryer Model
- Inlet / Outlet Flange kit (BSPP or NPT)
- Pre / Post Filtration (Grades A0 / AA / A0)
- FCD (Flow Control Device) - only required for multi-bank installations
- QRV - Part Number 608203833 for operation 9 bar g

Flow Control Device (FCD)

Why do I need a Flow Control Device for multi-bank installations?

When the compressed air requirements of a facility requires the installation of more than one single MX dryer, flow control devices (known as FCDs or sonic nozzles) must be fitted to the outlet of each dryer to protect it from overflow or preferential flow.

FCDs are sized to an installation and are designed to provide no more than 125% of the outlet flow of the dryer. If the system usage tries to overflow the dryer by more than 125% the FCD will restrict air flow, increasing differential pressure.

Benefits of Fitting a Flow Control Device:

- Prevents preferential or significant overflow of the dryer
- Helps to maintain a constant outlet pressure dewpoint
- Indicates by high pressure drop when system demand exceeds rated capacity



Example of a multi-bank installation

Flanged Connection Kits for MX Dryers

MX dryers do not include an inlet / outlet connection. When ordering an MX dryer the flanged connection kit must be ordered in addition to the dryer and must match the connection sizes of the inlet & outlet filtration.

When more than one dryer is installed (multi-bank installation), a Flow Control Device (FCD) is also required. The FCD will fit inside the outlet flange. Please order the appropriate inlet / outlet connection kit from the list below and FCD from the tables on the following pages.

The MX102c - MX103 dryers have 2" connections

608620076 FCD threaded connection 2" BSPP

608620078 FCD threaded connection 2" NPT

The MX104 - MX108 dryers have 2.5" connections

608620077 FCD threaded connection 2½" BSPP

608620079 FCD threaded connection 2½" NPT



608620077 thread connection kit (outlet flange on left)

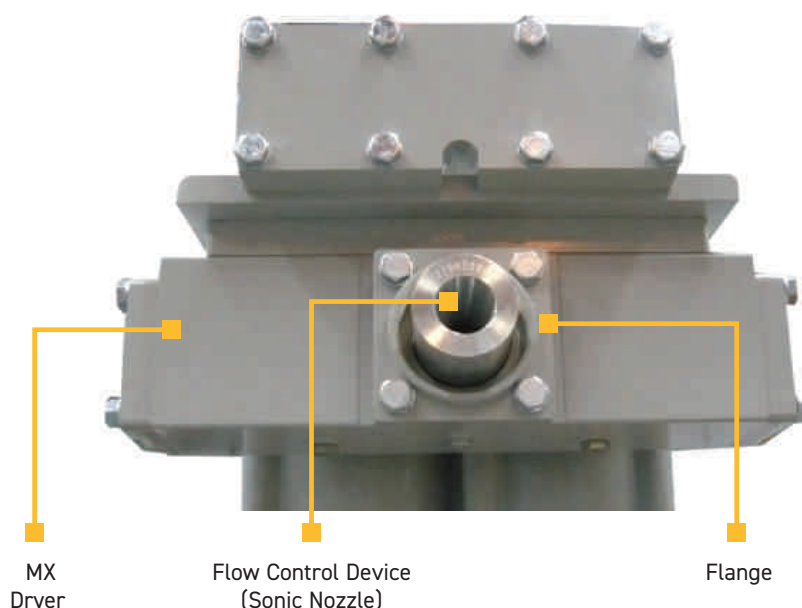

Flow Control Device (FCD) Product Selection For MX Heatless Dryer

To size FCDs correctly, the following information is required:

- Dryer model
- Dewpoint dryer has been sized to deliver
- Minimum inlet pressure
- Maximum inlet temperature

Sizing Example

The customer orders 2 x MXS108 and requires BSPP connections. The site parameters are an inlet temperature of 35°C, inlet pressure of 7 bar g, and a pressure dewpoint of -40°C. The FCD is 608620053, and the correct flange kit is 608620077.

35°C Inlet Temperature -20°C PDP								
Pressure	MX 102c	MX 103c	MX 103	MX 104	MX 105	MX 106	MX 107	MX 108
4 bar	608620009	608620014	608620017	608620021	608620043	608620046	608620049	608620052
5 bar	608620010	608620015	608620018	608620022	608620044	608620048	608620051	608620054
6 bar	608620011	608620015	608620018	608620023	608620045	608620048	608620052	608620055
7 bar	608620011	608620016	608620019	608620023	608620045	608620049	608620052	608620056
8 bar	608620011	608620016	608620019	608620024	608620046	608620050	608620053	608620056
9 bar	608620011	608620016	608620020	608620024	608620046	608620050	608620053	608620057
10 bar	608620012	608620017	608620020	608620024	608620047	608620050	608620054	608620057
11 bar	608620012	608620017	608620020	608620025	608620047	608620051	608620054	608620057
12 bar	608620012	608620017	608620020	608620025	608620047	608620051	608620054	Contact Parker
13 bar	608620012	608620017	608620020	608620025	608620047	608620051	608620054	Contact Parker

35°C Inlet Temperature -40°C PDP								
Pressure	MX 102c	MX 103c	MX 103	MX 104	MX 105	MX 106	MX 107	MX 108
4 bar	608620008	608620012	608620015	608620019	608620040	608620044	608620047	608620049
5 bar	608620009	608620013	608620016	608620020	608620042	608620045	608620048	608620051
6 bar	608620009	608620014	608620017	608620021	608620043	608620046	608620049	608620052
7 bar	608620010	608620014	608620017	608620022	608620043	608620047	608620050	608620053
8 bar	608620010	608620015	608620018	608620022	608620044	608620047	608620050	608620053
9 bar	608620010	608620015	608620018	608620022	608620044	608620048	608620051	608620054
10 bar	608620010	608620015	608620018	608620023	608620044	608620048	608620051	608620054
11 bar	608620011	608620015	608620018	608620023	608620045	608620048	608620052	608620055
12 bar	608620011	608620015	608620019	608620023	608620045	608620049	608620052	608620055
13 bar	608620011	608620016	608620019	608620023	608620045	608620049	608620052	608620055

35°C Inlet Temperature -70°C PDP								
Pressure	MX 102c	MX 103c	MX 103	MX 104	MX 105	MX 106	MX 107	MX 108
4 bar	608620008	608620012	608620015	608620019	608620040	608620044	608620047	608620049
5 bar	608620009	608620013	608620016	608620020	608620042	608620045	608620048	608620051
6 bar	608620009	608620014	608620017	608620021	608620043	608620046	608620049	608620052
7 bar	608620010	608620014	608620017	608620022	608620043	608620047	608620050	608620053
8 bar	608620010	608620015	608620018	608620022	608620044	608620047	608620050	608620053
9 bar	608620010	608620015	608620018	608620022	608620044	608620048	608620051	608620054
10 bar	608620010	608620015	608620018	608620023	608620044	608620048	608620051	608620054
11 bar	608620011	608620015	608620018	608620023	608620045	608620048	608620052	608620055
12 bar	608620011	608620015	608620019	608620023	608620045	608620049	608620052	608620055
13 bar	608620011	608620016	608620019	608620023	608620045	608620049	608620052	608620055

Flow Control Device (FCD) Product Selection For MX Heatless Dryer

40°C Inlet Temperature -20°C PDP								
Pressure	MX 102c	MX 103c	MX 103	MX 104	MX 105	MX 106	MX 107	MX 108
4 bar	608620009	608620014	608620016	608620021	608620042	608620046	608620049	608620051
5 bar	608620010	608620014	608620017	608620022	608620043	608620047	608620050	608620053
6 bar	608620010	608620015	608620018	608620022	608620044	608620048	608620051	608620054
7 bar	608620011	608620015	608620018	608620023	608620045	608620048	608620052	608620055
8 bar	608620011	608620016	608620019	608620023	608620045	608620049	608620052	608620055
9 bar	608620011	608620016	608620019	608620024	608620046	608620049	608620053	608620056
10 bar	608620011	608620016	608620019	608620024	608620046	608620050	608620053	608620056
11 bar	608620011	608620016	608620020	608620024	608620046	608620050	608620053	608620057
12 bar	608620012	608620017	608620020	608620024	608620047	608620050	608620054	608620057
13 bar	608620011	608620017	608620020	608620025	608620047	608620050	608620054	608620057

40°C Inlet Temperature -40°C PDP								
Pressure	MX 102c	MX 103c	MX 103	MX 104	MX 105	MX 106	MX 107	MX 108
4 bar	608620008	608620012	608620015	608620018	608620040	608620043	608620046	608620048
5 bar	608620009	608620013	608620016	608620020	608620042	608620044	608620047	608620050
6 bar	608620009	608620013	608620016	608620020	608620043	608620045	608620048	608620051
7 bar	608620009	608620014	608620017	608620021	608620043	608620046	608620059	608620052
8 bar	608620010	608620014	608620017	608620021	608620044	608620047	608620050	608620053
9 bar	608620010	608620015	608620017	608620022	608620044	608620047	608620050	608620053
10 bar	608620010	608620015	608620018	608620022	608620044	608620047	608620051	608620054
11 bar	608620010	608620015	608620018	608620022	608620045	608620048	608620051	608620054
12 bar	608620010	608620015	608620018	608620023	608620045	608620048	608620051	608620054
13 bar	608620010	608620015	608620018	608620023	608620045	608620048	608620051	608620054

40°C Inlet Temperature -70°C PDP								
Pressure	MX 102c	MX 103c	MX 103	MX 104	MX 105	MX 106	MX 107	MX 108
4 bar	608620003	608620006	608620008	608620011	608620032	608620034	608620036	608620038
5 bar	608620004	608620007	608620009	608620013	608620033	608620036	608620038	608620040
6 bar	608620005	608620008	608620010	608620014	608620034	608620037	608620039	608620042
7 bar	608620005	608620009	608620011	608620014	608620035	608620038	608620040	608620043
8 bar	608620006	608620009	608620012	608620015	608620036	608620039	608620041	608620043
9 bar	608620006	608620010	608620012	608620015	608620036	608620039	608620042	608620044
10 bar	608620006	608620010	608620012	608620016	608620037	608620040	608620042	608620045
11 bar	608620006	608620010	608620012	608620016	608620037	608620040	608620043	608620045
12 bar	608620006	608620010	608620013	608620016	608620037	608620040	608620043	608620045
13 bar	608620007	608620010	608620013	608620016	608620038	608620041	608620043	608620046

45°C Inlet Temperature -20°C PDP								
Pressure	MX 102c	MX 103c	MX 103	MX 104	MX 105	MX 106	MX 107	MX 108
4 bar	608620008	608620012	608620015	608620019	608620040	608620043	608620046	608620049
5 bar	608620009	608620013	608620016	608620020	608620041	608620044	608620047	608620050
6 bar	608620009	608620014	608620016	608620021	608620042	608620045	608620049	608620051
7 bar	608620009	608620014	608620017	608620021	608620043	608620046	608620049	608620052
8 bar	608620010	608620014	608620017	608620022	608620043	608620047	608620050	608620053
9 bar	608620010	608620015	608620018	608620022	608620044	608620047	608620050	608620053
10 bar	608620010	608620015	608620018	608620022	608620044	608620048	608620051	608620054
11 bar	608620010	608620015	608620018	608620022	608620044	608620048	608620051	608620054
12 bar	608620010	608620015	608620018	608620023	608620045	608620048	608620051	608620054
13 bar	608620011	608620015	608620018	608620023	608620045	608620048	608620051	608620054

45°C Inlet Temperature -40°C PDP								
Pressure	MX 102c	MX 103c	MX 103	MX 104	MX 105	MX 106	MX 107	MX 108
4 bar	608620007	608620010	608620013	608620016	608620038	608620041	608620043	608620046
5 bar	608620007	608620011	608620014	608620018	608620039	608620042	608620045	608620047
6 bar	608620008	608620012	608620015	608620019	608620040	608620043	608620046	608620049
7 bar	608620008	608620013	608620015	608620019	608620041	608620044	608620047	608620050
8 bar	608620009	608620013	608620016	608620020	608620041	608620045	608620047	608620050
9 bar	608620009	608620013	608620016	608620020	608620042	608620045	608620048	608620051
10 bar	608620009	608620013	608620016	608620020	608620042	608620045	608620048	608620051
11 bar	608620009	608620014	608620016	608620021	608620042	608620046	608620049	608620052
12 bar	608620009	608620014	608620017	608620021	608620042	608620046	608620049	608620052
13 bar	608620009	608620014	608620017	608620021	608620043	608620046	608620049	608620052

45°C Inlet Temperature -70°C PDP								
Pressure	MX 102c	MX 103c	MX 103	MX 104	MX 105	MX 106	MX 107	MX 108
4 bar	608620002	608620005	608620007	608620009	608620029	608620032	608620033	608620035
5 bar	608620003	608620006	608620008	608620011	608620031	608620034	608620036	608620038
6 bar	608620004	608620007	608620009	608620012	608620033	608620035	608620037	608620039
7 bar	608620004	608620008	608620010	608620013	608620034	608620036	608620038	608620040
8 bar	608620005	608620008	608620010	608620013	608620034	608620037	608620039	608620041
9 bar	608620005	608620008	608620011	608620014	608620035	608620037	608620040	608620042
10 bar	608620005	608620009	608620011	608620014	608620035	608620038	608620040	608620042
11 bar	608620005	608620009	608620011	608620015	608620036	608620038	608620041	608620043
12 bar	608620006	608620009	608620011	608620015	608620036	608620039	608620041	608620043
13 bar	608620006	608620009	608620012	608620015	608620036	608620039	608620041	608620044

Flow Control Device (FCD) Product Selection For MX Heatless Dryer

50°C Inlet Temperature -20°C PDP								
Pressure	MX 102c	MX 103c	MX 103	MX 104	MX 105	MX 106	MX 107	MX 108
4 bar	608620005	608620009	608620011	608620015	608620036	608620038	608620041	608620043
5 bar	608620006	608620010	608620012	608620026	608620037	608620040	608620043	608620045
6 bar	608620007	608620011	608620013	608620017	608620038	608620041	608620044	608620046
7 bar	608620007	608620011	608620014	608620018	608620039	608620042	608620045	608620047
8 bar	608620008	608620012	608620014	608620018	608620040	608620043	608620045	608620048
9 bar	608620008	608620012	608620015	608620019	608620040	608620043	608620046	608620049
10 bar	608620008	608620012	608620015	608620019	608620040	608620043	608620046	608620049
11 bar	608620008	608620012	608620015	608620019	608620041	608620044	608620047	608620049
12 bar	608620008	608620013	608620015	608620019	608620041	608620044	608620047	608620050
13 bar	608620008	608620013	608620016	608620020	608620041	608620044	608620047	608620050

50°C Inlet Temperature -40°C PDP								
Pressure	MX 102c	MX 103c	MX 103	MX 104	MX 105	MX 106	MX 107	MX 108
4 bar	608620004	608620007	608620010	608620013	608620033	608620036	608620038	608620040
5 bar	608620005	608620009	608620011	608620014	608620035	608620038	608620040	608620042
6 bar	608620006	608620009	608620012	608620015	608620036	608620039	608620041	608620044
7 bar	608620006	608620010	608620012	608620016	608620037	608620040	608620042	608620045
8 bar	608620007	608620010	608620013	608620016	608620038	608620040	608620043	608620046
9 bar	608620007	608620011	608620013	608620017	608620038	608620041	608620044	608620046
10 bar	608620007	608620011	608620013	608620017	608620038	608620041	608620044	608620047
11 bar	608620007	608620011	608620014	608620017	608620039	608620042	608620044	608620047
12 bar	608620007	608620011	608620014	608620018	608620039	608620042	608620045	608620047
13 bar	608620007	608620012	608620014	608620018	608620039	608620042	608620045	608620048

50°C Inlet Temperature -70°C PDP								
Pressure	MX 102c	MX 103c	MX 103	MX 104	MX 105	MX 106	MX 107	MX 108
4 bar	608620001	608620002	608620003	608620005	608620028	608620027	608620028	608620030
5 bar	608620001	608620003	608620005	608620007	608620028	608620029	608620031	608620033
6 bar	608620002	608620004	608620006	608620009	608620029	608620031	608620033	608620035
7 bar	608620002	608620005	608620007	608620010	608620030	608620032	608620034	608620036
8 bar	608620003	608620006	608620008	608620010	608620031	608620033	608620035	608620037
9 bar	608620003	608620006	608620008	608620011	608620031	608620034	608620036	608620038
10 bar	608620003	608620006	608620008	608620011	608620032	608620034	608620036	608620038
11 bar	608620004	608620007	608620009	608620012	608620032	608620035	608620037	608620039
12 bar	608620004	608620007	608620009	608620012	608620033	608620035	608620037	608620039
13 bar	608620004	608620007	608620009	608620012	608620033	608620035	608620038	608620040

MX Heatless Dryers (FAQs)

Does the dryer have a fault alarm relay fitted?

Yes, a single pole fault relay is fitted as standard.

Are the inlet valves normally open or normally closed?

The inlet valves on the MX dryer are normally closed as standard.

What is the power requirement of the dryer?

MXS, MXSDS = 15W. MXA = 35W.

What IP rating is the dryer?

IP65.

Is a QRV (Quick Re-pressurisation Valve) fitted as standard?

No, if the inlet pressure is equal to or greater than 9 bar, a QRV must be ordered with the dryer. Part Number: 608203833.

Why do I have 3 sets of purge plates in the packing crate?

As standard the dryer will be factory fitted with the 7 bar purge plates. If you are operating the dryer at a different pressure please use the appropriate purge plate.

MX Displays - MXS/DS

MXS display provides power and service interval indicators. The MXS dryer also comes complete with a digital display showing outlet pressure dewpoint and has a ECO display when the dryer is in energy saving mode.

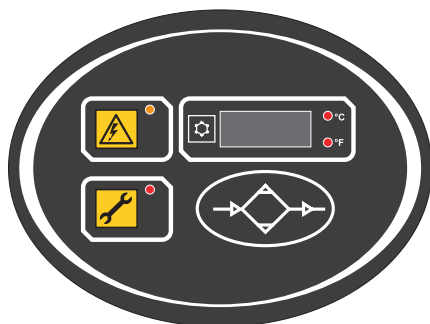

MXS DS Controller

Dewpoint Display
ECO - DDS active display
Sensor failure indication

Option

4-20mA dewpoint re-transmission

KE-MT Large Flow Heatless Adsorption Dryers

Dryer Performance

Dryer Models	Dewpoint (Standard)		ISO8573-1:2010 Classification (Standard)	Dewpoint (Option 1)		ISO8573-1:2010 Classification (Option 1)	Dewpoint (Option 2)		ISO8573-1:2010 Classification (Option 2)
	°C	°F		°C	°F		°C	°F	
KE-MT	-40	-40	Class 2.2.2	-70	-100	Class 2.1.2	-20	-4	Class 2.3.2

ISO8573-1 Classifications when used with OIL-X pre / post filtration

Technical Data

Dryer Models	Minimum Operating Pressure		Maximum Operating Pressure		Minimum Operating Temperature		Maximum Operating Temperature		Maximum Ambient Temperature		Electrical Supply (Standard)	Electrical Supply (Optional)	Thread Type	Noise Level dB(A)
	bar g	psi g	bar g	psi g	°C	°F	°C	°F	°C	°F				
KE-MT 250 - 600	5	73	10	145	5	41	50	122	50	122	230V 1ph 50Hz/60Hz	115V / 1ph 50/60Hz	Flange	65-95

Flow Rates

Model	Pipe Size	Inlet Flow Rate			
		L/s	m ³ /min	m ³ /hr	cfm
KE-MT 250	DN 80	695	42	2500	1472
KE-MT 300	DN 80	833	50	3000	1766
KE-MT 380	DN 100	1056	63	3800	2237
KE-MT 500	DN 100	1347	81	4850	2855
KE-MT 600	DN 125	1695	102	6100	3590

Stated flows are for operation at 7 bar (g) (102 psi g) with reference to 20°C, 1 bar (a), 0% relative water vapour pressure. For flows at other pressures, apply the correction factors shown below.

Product Selection & Correction Factors

For correct operation, compressed air dryers must be sized using for the maximum (summer) inlet temperature, maximum (summer) ambient temperature, minimum inlet pressure, required outlet dewpoint and maximum flow rate of the installation.

To select a dryer, first calculate the MDC (Minimum Drying Capacity) using the formula below then select a dryer from the flow rate table above with a flow rate equal to or above the MDC.

$$\text{Minimum Drying Capacity} = \text{System Flow} \times \text{CFMIT} \times \text{CFMAT} \times \text{CFMIP} \times \text{CFOD}$$

CFMIT - Correction Factor Maximum Inlet Temperature

Maximum Inlet Temperature	°C	25	30	35	40	45	50
	°F	77	86	95	104	113	122
Correction Factor		0.94	0.95	1.00	1.15	1.22	1.28

CFMAT - Correction Factor Maximum Ambient Temperature

Maximum Ambient Temperature	°C	25	30	35	40	45	50
	°F	77	86	95	104	113	122
Correction Factor		1.00	1.00	1.00	1.00	1.00	1.00

CFMIP - Correction Factor Minimum Inlet Pressure

Minimum Inlet Pressure	bar g	5	6	7	8	9	10
	psi g	73	87	100	116	131	145
Correction Factor		1.33	1.12	1.00	0.88	0.79	0.76

CFOD - Correction Factor Outlet Dewpoint

Outlet Dewpoint	°C	-25	-40	-70
	°F	-13	-40	-100
Correction Factor		1.00	1.00	2.00

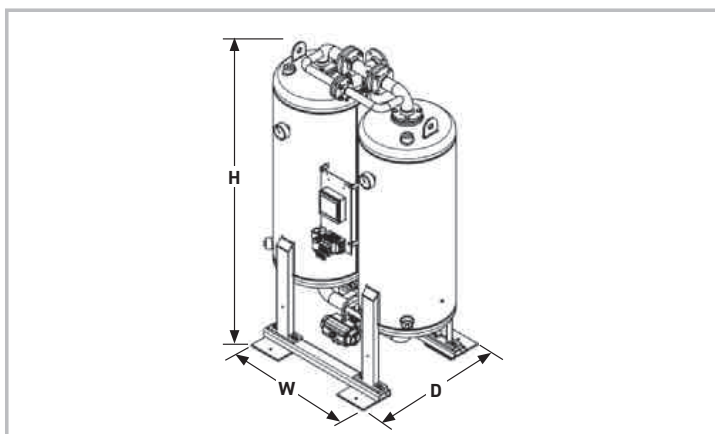

Weights & Dimensions

Model	Dimensions						Weight	
	Height (H)		Width (W)		Depth (D)			
	mm	ins	mm	ins	mm	ins	kg	lbs
KE-MT 250	1647	64.8	687	27.0	550	21.7	235	518
KE-MT 300	1647	64.8	856	33.7	550	21.7	316	696
KE-MT 380	1892	74.5	856	33.7	550	21.7	355	782
KE-MT 500	1892	74.5	1025	40.3	550	21.7	450	992
KE-MT 600	1892	74.5	1194	47.0	550	21.7	543	1197

Recommended Filtration

Model	Pipe Size BSPP or NPT	Dryer Inlet		Dryer Outlet		
		General Purpose Pre-filter	High Efficiency Filter	Oil Vapour Reduction Filter	General Purpose Dry Particulate Filter	High Efficiency Dry Particulate Filter
KE-MT 250	DN 80	AO070OD	AA070OD	-	AO070OD	-
KE-MT 300	DN 80	AO070OD	AA070OD	-	AO070OD	-
KE-MT 380	DN 100	AO070OD	AA070OD	-	AO070OD	-
KE-MT 500	DN 100	AO075PD	AA075PD	-	AO075PD	-
KE-MT 600	DN 125	AO075PD	AA075PD	-	AO075PD	-

Parker Catalogue Numbers

Model	Catalogue Number No Dewpoint Control	Catalogue Number With Dewpoint Control
KE-MT250	K250/10D1-F230M	K250/10D1-F230MT
KE-MT300	K300/10D1-F230M	K300/10D1-F230MT
KE-MT380	K380/10D1-F230M	K380/10D1-F230MT
KE-MT500	K500/10D1-F230M	K500/10D1-F230MT
KE-MT600	K600/10D1-F230M	K600/10D1-F230MT

MXLE Large Flow Heatless Low Energy Adsorption Dryers

Dryer Performance

Dryer Models	Dewpoint (Standard)		ISO8573-1:2010 Classification (Standard)	Dewpoint (Option 1)		ISO8573-1:2010 Classification (Option 1)	Dewpoint (Option 2)		ISO8573-1:2010 Classification (Option 2)
	°C	°F		°C	°F		°C	°F	
MXLE	-40	-40	Class 2.2.2	-70	-100	Class 2.1.2	-20	-4	Class 2.3.2

ISO8573-1 Classifications when used with OIL-X pre / post filtration

Technical Data

Dryer Models	Minimum Operating Pressure		Maximum Operating Pressure		Minimum Operating Temperature		Maximum Operating Temperature		Maximum Ambient Temperature		Electrical Supply (Standard)	Electrical Supply (Optional)	Thread Type	Noise Level dB(A)
	bar g	psi g	bar g	psi g	°C	°F	°C	°F	°C	°F				
MXLE 102C - MXLE 108	5	73	13	190	5	41	50	122	55	131	400V +/-10% 3PH 50Hz	460V +/-10% 3PH 60Hz	BSPP	<75

Flow Rates

Model	Pipe Size	Inlet Flow Rate			
		L/s	m³/min	m³/hr	cfm
MXLE 102C	2"	113	6.81	408	240
MXLE 103C	2"	170	10.22	612	360
MXLE 103	2"	213	12.75	765	450
MXLE 104	2½"	283	17	1020	600
MXLE 105	2½"	354	21	1275	750
MXLE 106	2½"	425	26	1530	900
MXLE 107	2½"	496	30	1785	1050
MXLE 108	2½"	567	34	2040	1200

For Higher Flow Capacities - Contact Parker

Vacuum Pump Part Number & kW

Vacuum Pump 50Hz	Pump kW 50Hz	Vacuum Pump 60Hz	Pump kW 60Hz
MXLEP2C-E	3	MXLEP2C-E-60	4.8
MXLEP3C-E	3	MXLEP3C-E-60	4.8
MXLEP3-E	4	MXLEP3-E-60	6.5
MXLEP4-E	5.5	MXLEP4-E-60	9
MXLEP5-E	5.5	MXLEP5-E-60	9
MXLEP6-E	8	MXLEP6-E-60	13
MXLEP7-E	9.5	MXLEP7-E-60	15.5
MXLEP8-E	9.5	MXLEP8-E-60	15.5

Dryer & vacuum pump to be ordered separately.

Stated flows are for operation at 7 bar (g) (102 psi g) with reference to 20°C, 1 bar (a), 0% relative water vapour pressure.

For flows at other pressures, apply the correction factors shown below.

Product Selection & Correction Factors

For correct operation, compressed air dryers must be sized using for the maximum (summer) inlet temperature, maximum (summer) ambient temperature, minimum inlet pressure, required outlet dewpoint and maximum flow rate of the installation.

To select a dryer, first calculate the MDC (Minimum Drying Capacity) using the formula below then select a dryer from the flow rate table above with a flow rate equal to or above the MDC.

Minimum Drying Capacity = System Flow x CFMIT x CFMAT x CFMIP x CFOD

CFMIT - Correction Factor Maximum Inlet Temperature

Maximum Inlet Temperature	°C	25	30	35	40	45	50
	°F	77	86	95	104	113	122
Correction Factor		1.00	1.00	1.00	1.04	1.14	1.37

CFMAT - Correction Factor Maximum Ambient Temperature

Maximum Ambient Temperature	°C	25	30	35	40	45	50
	°F	77	86	95	104	113	122
Correction Factor		1.00	1.00	1.00	1.00	1.00	1.00

CFMIP - Correction Factor Minimum Inlet Pressure

Minimum Inlet Pressure	bar g	4	5	6	7	8	9	10	11	12	13
	psi g	58	73	87	100	116	131	145	160	174	189
Correction Factor		1.60	1.33	1.14	1.00	0.89	0.80	0.73	0.67	0.62	0.57

CFOD - Correction Factor Outlet Dewpoint

Outlet Dewpoint	°C	-20	-40	-70
	°F	-4	-40	-100
Correction Factor		0.91	1.00	1.43

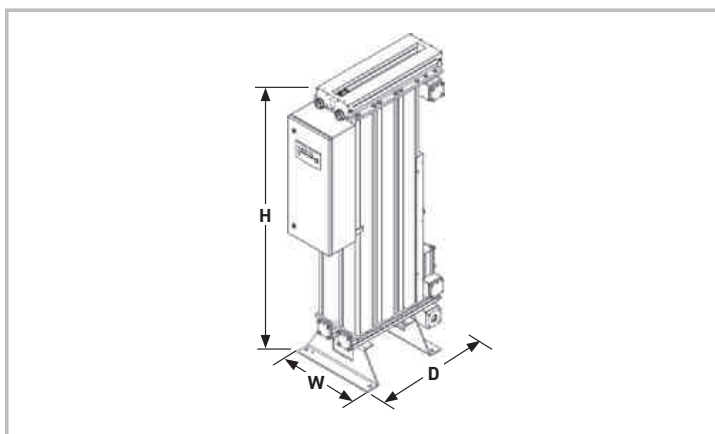

Included Filtration

Model	Pipe Size BSSP	Dryer Inlet		Dryer Outlet		
		General Purpose Pre-filter	High Efficiency Filter	Oil Vapour Reduction Filter	General Purpose Dry Particulate Filter	High Efficiency Dry Particulate Filter
MXLE 102C	2"	AOP040H	AAP040H	-	AOP040H	-
MXLE 103C	2"	AOP040H	AAP040H	-	AOP040H	-
MXLE 103	2"	AOP040H	AAP040H	-	AOP040H	-
MXLE 104	2½"	AOP045I	AAP045I	-	AOP045I	-
MXLE 105	2½"	AOP050I	AAP050I	-	AOP050I	-
MXLE 106	2½"	AOP050I	AAP050I	-	AOP050I	-
MXLE 107	2½"	AOP055I	AAP055I	-	AOP055I	-
MXLE 108	2½"	AOP055I	AAP055I	-	AOP055I	-

Weights & Dimensions

Model	Dimensions (Dryer Only)						Weight (Dryer Only)	
	Height (H)		Width (W)		Depth (D)		kg	lbs
	mm	ins	mm	ins	mm	ins		
MXLE 102C	1647	64.8	793	31.5	550	21.7	265	583
MXLE 103C	1647	64.8	962	37.9	550	21.7	346	761
MXLE 103	1892	74.5	962	37.9	550	21.7	385	847
MXLE 104	1892	74.5	1131	44.6	550	21.7	480	1056
MXLE 105	1892	74.5	1300	51.2	550	21.7	573	1261
MXLE 106	1892	74.5	1469	57.9	550	21.7	667	1467
MXLE 107	1892	74.5	1641	64.6	550	21.7	761	1674
MXLE 108	1892	74.5	1807	71.2	550	21.7	855	1881

Parker Catalogue Numbers

Model	Catalogue Number -20°C PDP / -40°C PDP	Catalogue Number -70°C PDP	50Hz Vacuum Pump Part Numbers	60Hz Vacuum Pump Part Numbers	Dryer Upgrade Kit Part Numbers
MXLE102C	MXLE102C	MXLE102C-70	MXLEP2C-E	MXLEP2C-E-60	MXLEK2C
MXLE103C	MXLE103C	MXLE103C-70	MXLEP3C-E	MXLEP3C-E-60	MXLEK3C
MXLE103	MXLE103	MXLE103-70	MXLEP3-E	MXLEP3-E-60	MXLEK3
MXLE104	MXLE104	MXLE104-70	MXLEP4-E	MXLEP4-E-60	MXLEK4
MXLE105	MXLE105	MXLE105-70	MXLEP5-E	MXLEP5-E-60	MXLEK5
MXLE106	MXLE106	MXLE106-70	MXLEP6-E	MXLEP6-E-60	MXLEK6
MXLE107	MXLE107	MXLE107-70	MXLEP7-E	MXLEP7-E-60	MXLEK7
MXLE108	MXLE108	MXLE108-70	MXLEP8-E	MXLEP8-E-60	MXLEK8

WVM Large Flow Vacuum Low Energy Adsorption Dryers

The new WVM Generation 5 will replace the existing WVM range in Q1 2020. Please contact Parker for product selection. Information on these pages refers to WVM Generation 4.

Dryer Performance

Dryer Models	Dewpoint (Standard)		ISO8573-1:2010 Classification (Standard)	Dewpoint (Option 1)		ISO8573-1:2010 Classification (Option 1)
	°C	°F		°C	°F	
WVM	-40	-40	Class 2.2.2	-20	-4	Class 2.3.2

ISO8573-1 Classifications when used with OIL-X pre / post filtration

Technical Data

Dryer Models	Minimum Operating Pressure		Maximum Operating Pressure		Minimum Operating Temperature		Maximum Operating Temperature		Maximum Ambient Temperature		Electrical Supply (Standard)	Electrical Supply (Optional)	Thread Type	Noise Level dB(A)
	bar g	psi g	bar g	psi g	°C	°F	°C	°F	°C	°F				
WVM	4	58	10	145	5	41	40	104	40	104	400V 3ph 50Hz	N/A	DIN Flange	<75

Flow Rates

Model	Pipe Size	Inlet Flow Rate				Average Power kW
		L/s	m³/min	m³/hr	cfm	
WVM 40	DN 40	117	7.00	420	247	3
WVM 50	DN 40	142	8.50	510	300	4
WVM 65	DN 50	178	10.67	640	377	5
WVM 85	DN 50	236	14.17	850	500	7
WVM 120	DN 80	328	19.67	1180	695	8
WVM 150	DN 80	417	25.00	1500	883	11
WVM 200	DN 80	550	33.00	1980	1165	12
WVM 235	DN 100	653	39.17	2350	1383	16
WVM 300	DN 100	814	48.83	2930	1725	20
WVM 355	DN 100	986	59.17	3550	2090	24
WVM 410	DN 150	1139	68.33	4100	2413	28
WVM 475	DN 150	1317	79.00	4740	2790	30
WVM 525	DN 150	1458	87.50	5250	3090	32
WVM 620	DN 150	1725	103.50	6210	3655	44
WVM 710	DN 150	1972	118.33	7100	4179	47
WVM 800	DN 200	2222	133.33	8000	4709	56
WVM 920	DN 200	2556	153.33	9200	5415	63
WVM 1080	DN 200	3000	180.00	10800	6357	72
WVM 1230	DN 250	3417	205.00	12300	7240	84
WVM 1450	DN 250	4028	242.67	14500	8535	98

Stated flows are for operation at 7 bar (g) (102 psi g) with reference to 20°C, 1 bar (a), 0% relative water vapour pressure. For flows at other pressures, apply the correction factors shown below.

Product Selection & Correction Factors

For correct operation, compressed air dryers must be sized using for the maximum (summer) inlet temperature, maximum (summer) ambient temperature, minimum inlet pressure, required outlet dewpoint and maximum flow rate of the installation.

Example: Outlet dewpoint required -40°C. Maximum inlet flow = 4095 m³/hr, at a minimum pressure of 9 bar g, and a maximum inlet temperature of 30 °C: The correction factor for those parameters (from the table below = 0.85) should be applied to the maximum inlet flow.

$$4095 \text{ m}^3/\text{hr} \times 0.85 = 3481 \text{ m}^3/\text{hr}.$$

Using the flow rates table above, select a dryer model with a flow rate equal to or greater than 3481 m³/hr.

Model selected = WVM 355

Correction Factors

	4 bar g (58 psi g)	5 bar g (73 psi g)	6 bar g (87 psi g)	7 bar g (102 psi g)	8 bar g (116 psi g)	9 bar g (131 psi g)	10 bar g (145 psi g)
30°C (86°F)	1.45	1.25	1.11	0.98	0.94	0.85	0.78
35°C (95°F)	2.27	1.61	1.25	1.00	0.95	0.86	0.78
40°C (104°F)	3.57	2.38	1.69	1.43	1.27	1.14	1.04

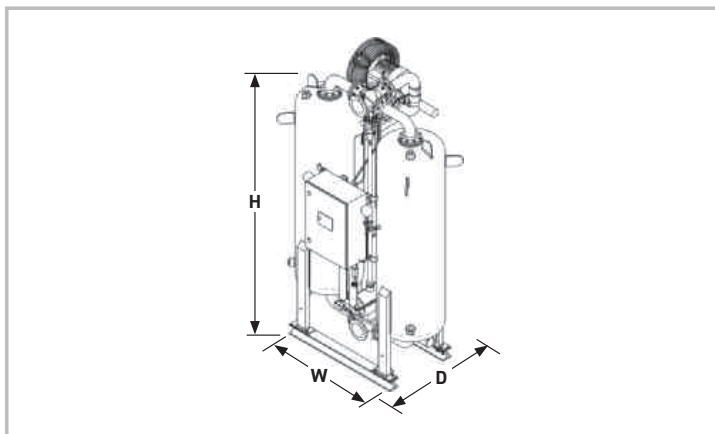

Weights & Dimensions

Model	Dimensions (Dryer Only)						Weight (Dryer Only)	
	Height (H)		Width (W)		Depth (D)		kg	lbs
	mm	ins	mm	ins	mm	ins		
WVM 40	2230	87.8	1140	44.9	990	39.0	770	1698
WVM 50	2230	87.8	1140	44.9	990	39.0	770	1698
WVM 65	2300	90.6	1260	49.6	1110	43.7	800	1764
WVM 85	2300	90.6	1260	49.6	1110	43.7	800	1764
WVM 120	2690	105.9	1460	57.5	1160	45.7	1150	2535
WVM 150	2700	106.3	1540	60.6	1200	47.2	1300	2866
WVM 200	2750	108.3	1605	63.2	1405	55.3	1650	3638
WVM 235	2870	113.0	2025	79.7	1490	58.7	2000	4409
WVM 300	2890	113.8	2050	80.7	1565	61.6	2250	4960
WVM 355	2960	116.5	2160	85.0	1750	68.9	2650	5842
WVM 410	3230	127.2	2430	95.7	1710	67.3	3250	7165
WVM 475	3260	128.3	2490	98.0	1710	67.3	3650	8047
WVM 525	3265	128.5	2550	100.4	1775	69.9	4050	8929
WVM 620	3540	139.4	2570	101.4	1865	73.4	4700	10362
WVM 710	3560	140.2	2635	103.7	1900	74.8	5050	11133
WVM 800	3625	142.7	3085	121.5	2110	83.1	6450	14220
WVM 920	3645	143.5	3125	123.0	2235	88.0	7500	16535
WVM 1080	3710	146.1	3225	127.0	2285	90.0	8700	19180
WVM 1230	4050	159.4	3475	136.8	2350	92.5	11900	26235
WVM 1450	4200	165.4	3500	137.8	2380	93.7	15870	34987

WVM Large Flow Vacuum Low Energy Adsorption Dryers

Recommended Filtration

Model	Pipe Size	Dryer Inlet		Dryer Outlet		
		General Purpose Pre-filter	High Efficiency Filter	Oil Vapour Reduction Filter	General Purpose Dry Particulate Filter	High Efficiency Dry Particulate Filter
WVM 40	DN 40	AOP035GGFX	AAP035GGFX	-	AOP035GGMX	-
WVM 50	DN 40	AOP035GGFX	AAP035GGFX	-	AOP035GGMX	-
WVM 65	DN 50	AOP040HGFX	AAP040HGFX	-	AOP040HGMX	-
WVM 85	DN 50	AOP045IGFX	AAP045IGFX	-	AOP045IGMX	-
WVM 120	DN 80	AO065NDFX	AA065NDFX	-	AO065NDMX	-
WVM 150	DN 80	AO065NDFX	AA065NDFX	-	AO065NDMX	-
WVM 200	DN 80	AO065NDFX	AA065NDFX	-	AO065NDMX	-
WVM 235	DN 100	AO070ODFX	AA070ODFX	-	AO070ODMX	-
WVM 300	DN 100	AO070ODFX	AA070ODFX	-	AO070ODMX	-
WVM 355	DN 100	AO070ODFX	AA070ODFX	-	AO070ODMX	-
WVM 410	DN 150	AO075PDFX	AA075PDFX	-	AO075PDMX	-
WVM 475	DN 150	AO075PDFX	AA075PDFX	-	AO075PDMX	-
WVM 525	DN 150	AO075PDFX	AA075PDFX	-	AO075PDMX	-
WVM 620	DN 150	AO075PDFX	AA075PDFX	-	AO075PDMX	-
WVM 710	DN 150	AO080PDFX	AA080PDFX	-	AO080PDMX	-
WVM 800	DN 200	AO085QDFX	AA085QDFX	-	AO085QDMX	-
WVM 920	DN 200	AO085QDFX	AA085QDFX	-	AO085QDMX	-
WVM 1080	DN 200	AO085QDFX	AA085QDFX	-	AO085QDMX	-
WVM 1230	DN 250	AO090RDFX	AA090RDFX	-	AO090RDMX	-
WVM 1450	DN 250	AO090RDFX	AA090RDFX	-	AO090RDMX	-

Parker Catalogue Numbers

Model	Catalogue Number Standard Dryer with Dewpoint Control	Catalogue Number Plus Vessel Insulation
WVM 40	W40/10VM4-F400CT	W40/10VM4-F400CT/I
WVM 50	W50/10VM4-F400CT	W50/10VM4-F400CT/I
WVM 65	W65/10VM4-F400CT	W65/10VM4-F400CT/I
WVM 85	W85/10VM4-F400CT	W85/10VM4-F400CT/I
WVM 120	W120/10VM4-F400CT	W120/10VM4-F400CT/I
WVM 150	W150/10VM4-F400CT	W150/10VM4-F400CT/I
WVM 200	W200/10VM4-F400CT	W200/10VM4-F400CT/I
WVM 235	W235/10VM4-F400CT	W235/10VM4-F400CT/I
WVM 300	W300/10VM4-F400CT	W300/10VM4-F400CT/I
WVM 355	W355/10VM4-F400CT	W355/10VM4-F400CT/I
WVM 410	W410/10VM4-F400CT	W410/10VM4-F400CT/I
WVM 475	W475/10VM4-F400CT	W475/10VM4-F400CT/I
WVM 525	W525/10VM4-F400CT	W525/10VM4-F400CT/I
WVM 620	W620/10VM4-F400CT	W620/10VM4-F400CT/I
WVM 710	W710/10VM4-F400CT	W710/10VM4-F400CT/I
WVM 800	W800/10VM4-F400CT	W800/10VM4-F400CT/I
WVM 920	W920/10VM4-F400CT	W920/10VM4-F400CT/I
WVM 1080	W1080/10VM4-F400CT	W1080/10VM4-F400CT/I
WVM 1230	W1230/10VM4-F400CT	W1230/10VM4-F400CT/I
WVM 1450	W1450/10VM4-F400CT	W1450/10VM4-F400CT/I

ATT Low Energy Hybrid Dryers

Dryer Performance

Dryer Models	Dewpoint (Standard)		ISO8573-1:2010 Classification (Standard)	Dewpoint (Option 1)		ISO8573-1:2010 Classification (Option 1)	Dewpoint (Option 2)		ISO8573-1:2010 Classification (Option 2)
	°C	°F		°C	°F		°C	°F	
ATT	-40	-40	Class 2.2.2	-70	-100	Class 2.1.2	-20	-4	Class 2.3.2

ISO8573-1 Classifications when used with OIL-X pre / post filtration

Technical Data

Dryer Models	Minimum Operating Pressure		Maximum Operating Pressure		Minimum Operating Temperature		Maximum Operating Temperature		Maximum Ambient Temperature		Electrical Supply (Standard)	Electrical Supply (Optional)	Thread Type	Noise Level dB(A)
	bar g	psi g	bar g	psi g	°C	°F	°C	°F	°C	°F				
ATT 040	2	29	16	232	5	41	65	149	50	122	230V 1ph 50Hz	N/A	BSPP	<75
ATT 060 - 090	2	29	12	174	5	41	65	149	50	122	230V 1ph 50Hz	N/A	BSPP	<75
ATT 090 - 140	2	29	12	174	5	41	65	149	50	122	400V 3ph 50Hz	N/A	BSPP	<75
ATT 260 - 340	4	58	12	174	5	41	65	149	50	122	400V 3ph 50Hz	N/A	BSPP	<75

Flow Rates

Model	Pipe Size	Inlet Flow Rate				Average Power kW
		L/s	m³/min	m³/hr	cfm	
ATT 040	1"	67	4	240	141	1.3
ATT 060	1½"	100	6	360	212	1.27
ATT 090	1½"	150	9	540	318	1.94
ATT 140	2"	233	14	840	494	2.01
ATT 260	2½"	433	26	1560	918	4.02
ATT 340	2½"	567	34	2040	1200	5.17

Stated flows are for operation at 7 bar (g) (102 psi g) with reference to 20°C, 1 bar (a), 0% relative water vapour pressure.

For flows at other pressures, apply the correction factors shown below.

Product Selection & Correction Factors

For correct operation, compressed air dryers must be sized using for the maximum (summer) inlet temperature, maximum (summer) ambient temperature, minimum inlet pressure, required outlet dewpoint and maximum flow rate of the installation.

To select a dryer, first calculate the MDC (Minimum Drying Capacity) using the formula below then select a dryer from the flow rate table above with a flow rate equal to or above the MDC.

$$\text{Minimum Drying Capacity} = \text{System Flow} \times \text{CFMIT} \times \text{CFMAT} \times \text{CFMIP} \times \text{CFOD}$$

CFMIT - Correction Factor Maximum Inlet Temperature

Maximum Inlet Temperature	°C	25	30	35	40	45	50	55	60	65
	°F	77	86	95	104	113	122	131	140	149
Correction Factor 040 - 340		0.82	0.82	1.00	1.23	1.45	1.69	1.92	2.17	2.50

CFMAT - Correction Factor Maximum Ambient Temperature

Maximum Ambient Temperature	°C	20	25	30	35	40	45	50
	°F	68	77	86	95	104	113	122
Correction Factor 040 - 060		0.95	1.00	1.06	1.14	1.23	1.33	1.47
Correction Factor 090 - 340		0.94	1.00	1.05	1.11	1.20	1.30	1.39

CFMIP - Correction Factor Minimum Inlet Pressure

Minimum Inlet Pressure	bar g	4	5	6	7	8	9	10	11	12	13	14	15	16
	psi g	58	73	87	100	116	131	145	160	174	189	203	218	232
Correction Factor 040		1.61	1.33	1.15	1.00	0.93	0.83	0.78	0.75	0.71	0.69	0.67	0.65	0.63
Correction Factor 060 - 340		1.61	1.33	1.15	1.00	0.93	0.83	0.78	0.75	0.71	N/A	N/A	N/A	N/A

CFOD - Correction Factor Outlet Dewpoint

Outlet Dewpoint	°C	-20	-40	-70
	°F	-4	-40	-100
Correction Factor		1	1	1

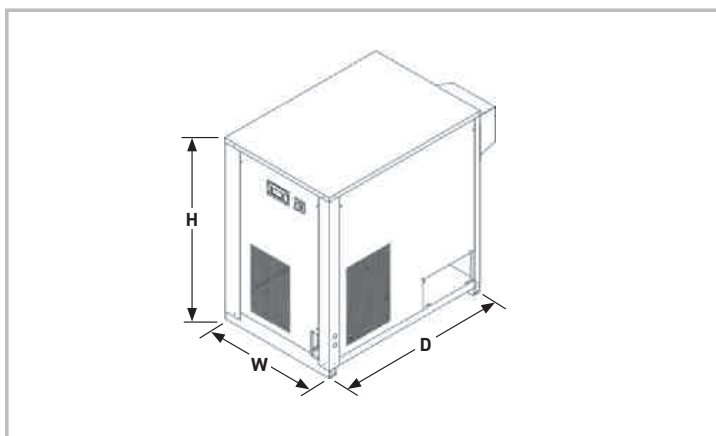

Weights & Dimensions

Model	Dimensions (Dryer Only)						Weight (Dryer Only)	
	Height (H)		Width (W)		Depth (D)		kg	lbs
	mm	ins	mm	ins	mm	ins		
ATT 040	1064	41.9	706	27.8	1246	49.1	200	441
ATT 060	1214	47.8	806	31.7	1416	55.7	295	650
ATT 090	1214	47.8	806	31.7	1416	55.7	335	739
ATT 140	1586	62.4	1007	39.6	1345	53.0	490	1080
ATT 260	1720	67.7	1007	39.6	2535	99.8	880	1940
ATT 340	1720	67.7	1007	39.6	2535	99.8	950	2094

Included Filtration

Model	Pipe Size BSPP	Dryer Inlet		Dryer Outlet		
		General Purpose Pre-filter	High Efficiency Filter	Oil Vapour Reduction Filter	General Purpose Dry Particulate Filter	High Efficiency Dry Particulate Filter
ATT 040	1"	AOP030G	AAP030G	-	AOP030G	-
ATT 060	1½"	AOP030G	AAP030G	-	AOP030G	-
ATT 090	1½"	AOP035G	AAP035G	-	AOP035G	-
ATT 140	2"	AOP045I	AAP045I	-	AOP045I	-
ATT 260	2½"	AOP055J	AAP055J	-	AOP055J	-
ATT 340	2½"	AOP055J	AAP055J	-	AOP055J	-

Parker Catalogue Numbers

Model	Catalogue Number Standard	Catalogue Number With By-Pass	Catalogue Number With Touchscreen	Catalogue Number With By-Pass & Touchscreen
ATT 040	ATT040-A23015016TI	-	-	-
ATT 060	ATT060-A23015012TI	ATT060-A23015012TITB	-	-
ATT 090	ATT090-A23015012TI	ATT090-A23015012TITB	-	-
ATT 140	ATT140-A40035012EI	ATT140-A40035012EITB	ATT140-A40035012EITS	ATT140-A40035012EITBTS
ATT 260	ATT260-A40035012EI	ATT260-A40035012EITB	ATT260-A40035012EITS	ATT260-A40035012EITBTS
ATT 340	ATT340-A40035012EI	ATT340-A40035012EITB	ATT340-A40035012EITS	ATT340-A40035012EITBTS

SPE Direct Expansion Refrigeration Dryers

Dryer Performance

Dryer Models	Dewpoint (Standard)		Dewpoint (Option 1)		Dewpoint (Option 2)	
	°C	°F	°C	°F	°C	°F
SPE	+3	+37	+7	+45	+10	+50

Technical Data

Dryer Models	Minimum Operating Pressure		Maximum Operating Pressure		Minimum Operating Temperature		Maximum Operating Temperature		Maximum Ambient Temperature		Electrical Supply (Standard)	Electrical Supply (Optional)	Thread Connections	Noise Level
	bar g	psi g	bar g	psi g	°C	°F	°C	°F	°C	°F				
	dB(A)													
SPE 004-062	2	29	16	232	5	41	65	149	50	122	230V 1ph 50Hz / 60Hz	N/A	BSPP	<75
SPE 080-100			14	203										

Flow Rates

Model	Pipe Size	Inlet Flow Rate 50 Hz					50Hz kW	Inlet Flow Rate 60Hz				60Hz kW	Stated flows are for operation at 7 bar (g) (102 psi g) with reference to 20°C, 1 bar (a), 0% relative water vapour pressure, 25°C cooling air temperature, 35°C air inlet temperature and +3°C pressure dewpoint. All models supplied with refrigerant R134a For flows at other conditions, apply the correction factors shown below.
		L/s	m³/min	m³/hr	cfm			L/s	m³/min	m³/hr	cfm		
SPE 004	½"	7	0.4	24	14	0.13	8	0.47	28	16	0.16		
SPE 007	½"	12	0.7	42	25	0.14	13	0.78	47	28	0.17		
SPE 009	½"	15	0.9	54	32	0.15	17	1.00	60	35	0.19		
SPE 014	¾"	23	1.4	84	49	0.15	27	1.60	96	57	0.18		
SPE 018	¾"	30	1.8	108	64	0.16	34	2.07	124	73	0.20		
SPE 026	1"	43	2.6	156	92	0.29	49	2.93	176	104	0.36		
SPE 032	1"	53	3.2	192	113	0.30	61	3.63	218	128	0.37		
SPE 040	1"	67	4.0	240	141	0.31	76	4.53	272	160	0.38		
SPE 052	1½"	87	5.2	312	184	0.46	100	6.02	361	212	0.56		
SPE 062	1½"	103	6.2	372	219	0.57	119	7.15	429	253	0.69		
SPE 080	1½"	133	8.0	480	282	0.73	154	9.25	555	327	0.90		
SPE 100	1½"	167	10.0	600	353	0.74	191	11.48	689	406	0.91		

Product Selection & Correction Factors

For correct operation, compressed air dryers must be sized using for the maximum (summer) inlet temperature, maximum (summer) ambient temperature, minimum inlet pressure, required outlet dewpoint and maximum flow rate of the installation.

To select a dryer, first calculate the MDC (Minimum Drying Capacity) using the formula below then select a dryer from the flow rate table above with a flow rate equal to or above the MDC.

$$\text{Minimum Drying Capacity} = \text{System Flow} \times \text{CFMIT} \times \text{CFMAT} \times \text{CFMIP} \times \text{CFOD}$$

CFMIT - Correction Factor Maximum Inlet Temperature

Maximum Inlet Temperature	°C	25	30	35	40	45	50	55	60	65
	°F	77	86	95	104	113	122	131	140	149
Correction Factor	50Hz	0.83	0.83	1.00	1.30	1.61	2.00	2.33	2.38	2.50
	60Hz	0.85	0.85	1.00	1.32	1.61	2.04	2.56	2.63	2.78

CFMAT - Correction Factor Maximum Ambient Temperature

Maximum Ambient Temperature	°C	20	25	30	35	40	45	50
	°F	68	77	86	95	104	113	122
Correction Factor	50Hz	0.93	1.00	1.02	1.09	1.15	1.22	1.28
	60Hz	0.96	1.00	1.06	1.11	1.18	1.25	1.33

CFMIP - Correction Factor Minimum Inlet Pressure

Minimum Inlet Pressure	bar g	3	4	5	6	7	8	9	10	11	12	13	14	15	16
	psi g	44	58	73	87	100	116	131	145	160	174	189	203	218	232
Correction Factor	50Hz	1.35	1.23	1.11	1.06	1.00	0.93	0.85	0.83	0.81	0.79	0.77	0.75	0.73	0.71
	60Hz	1.45	1.23	1.11	1.06	1.00	0.93	0.85	0.83	0.81	0.79	0.77	0.75	0.73	0.71

CFOD - Correction Factor Outlet Dewpoint

Outlet Dewpoint	°C	+3	+5	+7
	°F	+37	+41	+45
Correction Factor	50Hz	1.00	0.78	0.70
	60Hz	1.00	0.79	0.72

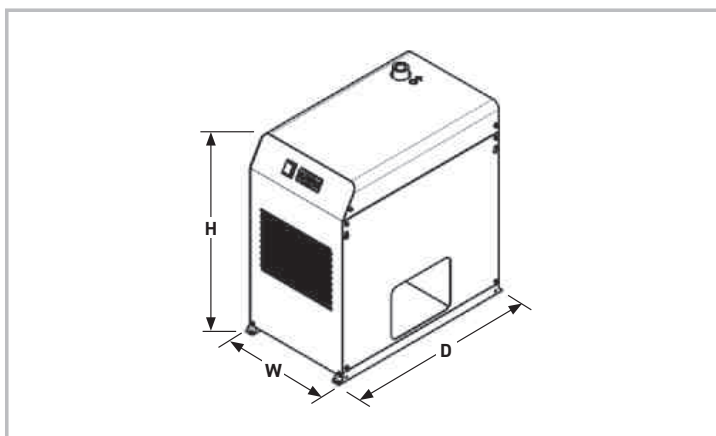

Weights & Dimensions

Model	Dimensions						Weight	
	Height (H)		Width (W)		Depth (D)			
	mm	ins	mm	ins	mm	ins	kg	lbs
SPE 004	520	20.5	300	11.8	400	15.7	24	53
SPE 007	520	20.5	300	11.8	400	15.7	24	53
SPE 009	520	20.5	300	11.8	400	15.7	25	55
SPE 014	580	22.8	330	13.0	550	21.7	35	77
SPE 018	580	25.6	330	13.0	550	21.7	36	79
SPE 026	650	25.6	400	15.7	630	24.8	46	101
SPE 032	650	25.6	400	15.7	630	24.8	46	101
SPE 040	650	25.6	400	15.7	630	24.8	47	104
SPE 052	650	25.6	400	15.7	630	24.8	53	117
SPE 062	650	25.6	400	15.7	630	24.8	55	121
SPE 080	840	33.1	450	17.7	780	30.7	80	176
SPE 100	840	33.1	450	17.7	780	30.7	80	176

Recommended Filtration

Pipe Size BSPP	Dryer Inlet	Dryer Outlet
	General Purpose Pre-Filter	High Efficiency Post Filter
1/2"	AOP010C	AAP010C
1/2"	AOP015C	AAP015C
1/2"	AOP015C	AAP015C
3/4"	AOP020D	AAP020D
3/4"	AOP020D	AAP020D
1"	AOP025E	AAP025E
1"	AOP025E	AAP025E
1"	AOP025E	AAP025E
1 1/2"	AOP030G	AAP030G
1 1/2"	AOP030G	AAP030G
1 1/2"	AOP035G	AAP035G
1 1/2"	AOP035G	AAP035G

Parker Catalogue Numbers

Model	Catalogue Number With Timed Drain	Catalogue Number With Electronic Drain	Catalogue Number With Electronic Drain & Energy Saving	Catalogue Number With External Float Drain
SPE 004	SPE004-A2301DF16TIS	SPE004-A2301DF16EXS	-	SPE004-A2301DF16FHS
SPE 007	SPE007-A2301DF16TIS	SPE007-A2301DF16EXS	-	SPE007-A2301DF16FHS
SPE 009	SPE009-A2301DF16TIS	SPE009-A2301DF16EXS	-	SPE009-A2301DF16FHS
SPE 014	SPE014-A2301DF16TIS	SPE014-A2301DF16EXS	-	SPE014-A2301DF16FHS
SPE 018	SPE018-A2301DF16TIS	SPE018-A2301DF16EXS	-	SPE018-A2301DF16FHS
SPE 026	SPE026-A2301DF16TIS	SPE026-A2301DF16EXS	SPE026-A2301DF16EXSES	SPE026-A2301DF16FHS
SPE 032	SPE032-A2301DF16TIS	SPE032-A2301DF16EXS	SPE032-A2301DF16EXSES	SPE032-A2301DF16FHS
SPE 040	SPE040-A2301DF16TIS	SPE040-A2301DF16EXS	SPE040-A2301DF16EXSES	SPE040-A2301DF16FHS
SPE 052	SPE052-A2301DF16TIS	SPE052-A2301DF16EXS	SPE052-A2301DF16EXSES	SPE052-A2301DF16FHS
SPE 062	SPE062-A2301DF16TIS	SPE062-A2301DF16EXS	SPE062-A2301DF16EXSES	SPE062-A2301DF16FHS
SPE 080	SPE080-A2301DF14TIS	SPE080-A2301DF14EXS	SPE080-A2301DF14EXSES	SPE080-A2301DF14FHS
SPE 100	SPE100-A2301DF14TIS	SPE100-A2301DF14EXS	SPE100-A2301DF14EXSES	SPE100-A2301DF14FHS

PST Direct Expansion Refrigeration Dryers

Dryer Performance

Dryer Models	Dewpoint (Standard)		Dewpoint (Option 1)		Dewpoint (Option 2)	
	°C	°F	°C	°F	°C	°F
PST	+3	+37	+7	+45	+10	+50

Technical Data

Dryer Models	Minimum Operating Pressure		Maximum Operating Pressure		Minimum Operating Temperature		Maximum Operating Temperature		Maximum Ambient Temperature		Electrical Supply (Standard)	Electrical Supply (Optional)	Thread Connections	Noise Level dB(A)
	bar g	psi g	bar g	psi g	°C	°F	°C	°F	°C	°F				
PST 0120 - 1800	2	29	14	203	5	41	65	149	50	122	400V 3ph 50Hz	N/A	BSPP & DIN Flange	<75

Flow Rates

Model	Pipe Size	Inlet Flow Rate				Average Power kW
		L/s	m³/min	m³/hr	cfm	
PST 120	2"	200	12	720	424	1.13
PST 140	2"	233	14	840	494	1.14
PST 180	2"	300	18	1080	636	1.46
PST 220	2½"	367	22	1320	777	1.68
PST 260	2½"	433	26	1560	918	2.19
PST 300	2½"	500	30	1800	1059	2.41
PST 350	2½"	583	35	2100	1236	3.06
PST 460	DN100	767	46	2760	1625	3.14
PST 520	DN100	867	52	3120	1836	3.54
PST 630	DN100	1050	63	3780	2225	4.64
PST 750	DN150	1250	75	4500	2649	5.73
PST 900	DN150	1500	90	5400	3178	7.63
PST 1200	DN150	2000	120	7200	4238	8.92
PST 1500	DN200	2500	150	9000	5297	12.35
PST 1800	DN200	3000	180	10800	6357	15.96

Stated flows are for operation at 7 bar (g) (102 psi g) with reference to 20°C, 1 bar (a), 0% relative water vapour pressure, 25°C cooling air temperature, 35 °C air inlet temperature and +3°C pressure dewpoint. All models supplied with refrigerant R407C.

For flows at other conditions, apply the correction factors shown below.

Product Selection & Correction Factors

For correct operation, compressed air dryers must be sized using for the maximum (summer) inlet temperature, maximum (summer) ambient temperature, minimum inlet pressure, required outlet dewpoint and maximum flow rate of the installation.

To select a dryer, first calculate the MDC (Minimum Drying Capacity) using the formula below then select a dryer from the flow rate table above with a flow rate equal to or above the MDC.

$$\text{Minimum Drying Capacity} = \text{System Flow} \times \text{CFMIT} \times \text{CFMAT} \times \text{CFMIP} \times \text{CFOD}$$

CFMIT - Correction Factor Maximum Inlet Temperature

Maximum Inlet Temperature	°C	25	30	35	40	45	50	55	60	65
	°F	77	86	95	104	113	122	131	140	149
Correction Factor		0.81	0.81	1.00	1.19	1.43	1.69	2.00	2.22	2.50

CFMAT - Correction Factor Maximum Ambient Temperature

Maximum Ambient Temperature	°C	20	25	30	35	40	45	50
	°F	68	77	86	95	104	113	122
Correction Factor		0.94	1.00	1.05	1.11	1.20	1.30	1.39

CFMIP - Correction Factor Minimum Inlet Pressure

Minimum Inlet Pressure	bar g	3	4	5	6	7	8	9	10	11	12	13	14
	psi g	44	58	73	87	100	116	131	145	160	174	189	203
Correction Factor		1.35	1.20	1.11	1.04	1.00	0.96	0.93	0.93	0.90	0.89	0.88	0.87

CFOD - Correction Factor Outlet Dewpoint

Outlet Dewpoint	°C	+3	+5	+7	+10
	°F	+37	+41	+45	+50
Correction Factor		1.00	0.91	0.83	0.71

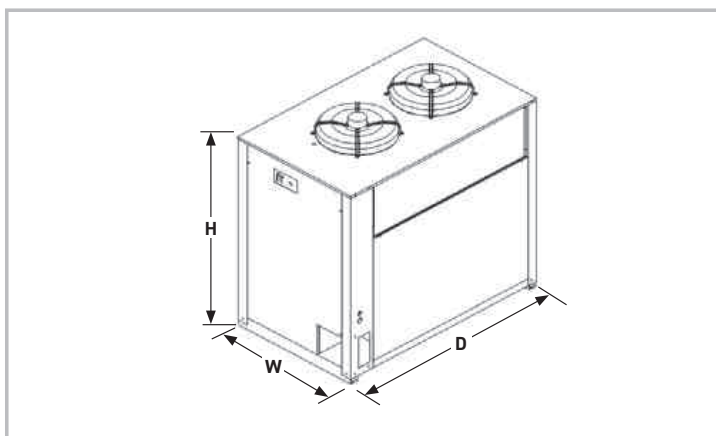

Weights & Dimensions

Model	Dimensions						Weight	
	Height (H)		Width (W)		Depth (D)			
	mm	ins	mm	ins	mm	ins	kg	lbs
PST 120	1064	41.9	706	27.8	1046	41.2	145	320
PST 140	1064	41.9	706	27.8	1046	41.2	145	320
PST 180	1064	41.9	706	27.8	1046	41.2	155	342
PST 220	1316	51.8	806	31.7	1166	45.9	230	507
PST 260	1316	51.8	806	31.7	1166	45.9	240	529
PST 300	1316	51.8	806	31.7	1166	45.9	245	540
PST 350	1316	51.8	806	31.7	1166	45.9	250	551
PST 460	1690	66.5	1007	39.6	1097	43.2	470	1036
PST 520	1722	67.8	1007	39.6	1097	43.2	490	1080
PST 630	1722	67.8	1007	39.6	1657	65.2	580	1279
PST 750	1722	67.8	1007	39.6	1657	65.2	670	1477
PST 900	1722	67.8	1007	39.6	1657	65.2	690	1521
PST 1200	2048	80.6	1007	39.6	1657	65.2	830	1830
PST 1500	2208	86.9	1007	39.6	2257	88.9	1100	2425
PST 1800	2208	86.9	1007	39.6	2257	88.9	1190	2623

Recommended Filtration

Pipe Size BSPP	Dryer Inlet	Dryer Outlet
	General Purpose Pre-Filter	High Efficiency Post Filter
2"	AOP040H	AAP040H
2"	AOP040H	AAP040H
2"	AOP045I	AAP045I
2½"	AOP050I	AAP050I
2½"	AOP055I	AAP055I
2½"	AOP055I	AAP055I
2½"	AOP055I	AAP055I
DN100	AO070O	AA070O
DN100	AO070O	AA070O
DN100	AO070O	AA070O
DN150	AO075P	AA075P
DN150	AO075P	AA075P
DN150	AO080P	AA080P
DN200	AO085Q	AA085Q
DN200	AO085Q	AA085Q

Parker Catalogue Numbers

Model	50Hz Air Cooled		50Hz Water Cooled		60Hz Air Cooled		60Hz Water Cooled	
	Catalogue Number	Catalogue Number	Catalogue Number	Catalogue Number	Catalogue Number	Catalogue Number	Catalogue Number	
PST 120	PST120-A40035014EI	-	-	-	PST130-A46036014EI	-	-	
PST 140	PST140-A40035014EI	-	-	-	PST150-A46036014EI	-	-	
PST 180	PST180-A40035014EI	-	-	-	PST250-A46036014EI	PST250-W46036014EI	-	
PST 220	PST220-A40035014EI	PST220-W40035014EI	-	-	PST280-A46036014EI	PST280-W46036014EI	-	
PST 260	PST260-A40035014EI	PST260-W40035014EI	-	-	PST340-A46036014EI	PST340-W46036014EI	-	
PST 300	PST300-A40035014EI	PST300-W40035014EI	-	-	PST390-A46036014EI	PST390-W46036014EI	-	
PST 350	PST350-A40035014EI	PST350-W40035014EI	-	-	PST490-A46036014EI	PST490-W46036014EI	-	
PST 460	PST460-A40035014EI	PST460-W40035014EI	-	-	PST560-A46036014EI	PST560-W46036014EI	-	
PST 520	PST520-A40035014EI	PST520-W40035014EI	-	-	PST700-A46036014EI	PST700-W46036014EI	-	
PST 630	PST630-A40035014EI	PST630-W40035014EI	-	-	PST840-A46036014EI	PST840-W46036014EI	-	
PST 750	PST750-A40035014EI	PST750-W40035014EI	-	-	PST1020-A46036014EI	PST1020-W46036014EI	-	
PST 900	PST900-A40035014EI	PST900-W40035014EI	-	-	PST1320-A46036014EI	PST1320-W46036014EI	-	
PST 1200	PST1200-A40035014EI	PST1200-W40035014EI	-	-	PST1650-A46036014EI	PST1650-W46036014EI	-	
PST 1500	PST1500-A40035014EI	PST1500-W40035014EI	-	-	PST1980-A46036014EI	PST1980-W46036014EI	-	
PST 1800	PST1800-A40035014EI	PST1800-W40035014EI	-	-	-	-	-	

PST Twin Direct Expansion Refrigeration Dryers

Dryer Performance

Dryer Models	Dewpoint (Standard)		Dewpoint (Option 1)		Dewpoint (Option 2)	
	°C	°F	°C	°F	°C	°F
PST	+3	+37	+7	+45	+10	+50

Technical Data

Dryer Models	Minimum Operating Pressure		Maximum Operating Pressure		Minimum Operating Temperature		Maximum Operating Temperature		Maximum Ambient Temperature		Electrical Supply (Standard)	Electrical Supply (Optional)	Thread Connections	Noise Level dB(A)
	bar g	psi g	bar g	psi g	°C	°F	°C	°F	°C	°F				
PST 2400 - 3600	2	29	14	203	5	41	65	149	50	122	400V 3ph 50Hz	N/A	DIN Flange	<75

Flow Rates

Model	Pipe Size	Inlet Flow Rate				Average Power kW
		L/s	m ³ /min	m ³ /hr	cfm	
PST 2400	DN200	4000	240	14400	8470	18
PST 3000	DN250	5000	300	18000	10588	25
PST 3600	DN250	6000	360	21600	12705	32

Stated flows are for operation at 7 bar (g) (102 psi g) with reference to 20°C, 1 bar (a), 0% relative water vapour pressure, 25°C cooling air temperature, 35 °C air inlet temperature and +3°C pressure dewpoint. All models supplied with refrigerant R407C.

For flows at other conditions, apply the correction factors shown below.

Product Selection & Correction Factors

For correct operation, compressed air dryers must be sized using for the maximum (summer) inlet temperature, maximum (summer) ambient temperature, minimum inlet pressure, required outlet dewpoint and maximum flow rate of the installation.

To select a dryer, first calculate the MDC (Minimum Drying Capacity) using the formula below then select a dryer from the flow rate table above with a flow rate equal to or above the MDC.

$$\text{Minimum Drying Capacity} = \text{System Flow} \times \text{CFMIT} \times \text{CFMAT} \times \text{CFMIP} \times \text{CFOD}$$

CFMIT - Correction Factor Maximum Inlet Temperature

Maximum Inlet Temperature	°C	25	30	35	40	45	50	55	60	65
	°F	77	86	95	104	113	122	131	140	149
Correction Factor		0.81	0.81	1.00	1.19	1.43	1.69	2.00	2.22	2.50

CFMAT - Correction Factor Maximum Ambient Temperature

Maximum Ambient Temperature	°C	20	25	30	35	40	45	50
	°F	68	77	86	95	104	113	122
Correction Factor		0.94	1.00	1.05	1.11	1.20	1.30	1.39

CFMIP - Correction Factor Minimum Inlet Pressure

Minimum Inlet Pressure	bar g	3	4	5	6	7	8	9	10	11	12	13	14
	psi g	44	58	73	87	100	116	131	145	160	174	189	203
Correction Factor		1.35	1.20	1.11	1.04	1.00	0.96	0.93	0.93	0.90	0.89	0.88	0.87

CFOD - Correction Factor Outlet Dewpoint

Outlet Dewpoint	°C	+3	+5	+7	+10
	°F	+37	+41	+45	+50
Correction Factor		1.00	0.91	0.83	0.71

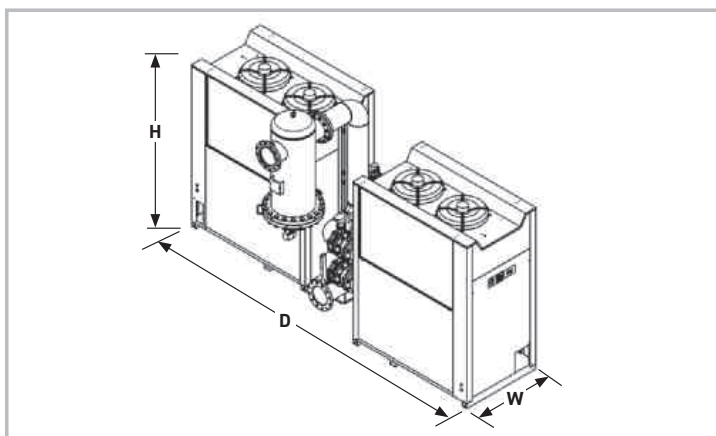

Weights & Dimensions

Model	Dimensions						Weight	
	Height (H)		Width (W)		Depth (D)			
	mm	ins	mm	ins	mm	ins	kg	lbs
PST 2400	2736	107.7	2007	79.0	4148	163.3	2335	5148
PST 3000	2834	111.6	3279	129.1	2753	108.4	2930	6460
PST 3600	2834	111.6	3279	129.1	2753	108.4	3150	6945

Recommended Filtration

Pipe Size BSP	Dryer Inlet	Dryer Outlet
	General Purpose Pre-Filter	High Efficiency Post Filter
DN200	AO085Q	AA085Q
DN250	A0090R	AA090R
DN250	AO090R	AA090R

Parker Catalogue Numbers

Model	Catalogue Number Air Cooled*	Catalogue Number Water Cooled*
PST 2400	PST2400-A40035014EITF	PST2400-W40035014EITF
PST 3000	PST3000-A40035014EITF	PST3000-W40035014EITF
PST 3600	PST3600-A40035014EITF	PST3600-W40035014EITF

* Dryer part number includes general purpose pre-filter.

IP50 - 50 Bar Compressed Air Filters

Filtration Performance

Filtration Grade	Filter Type	Particle Reduction (inc water & oil aerosols)	Maximum Remaining Oil Content at 21°C (70°F)	Filtration Efficiency	Initial Dry Differential Pressure	Initial Saturated Differential Pressure	Change Element Every	Precede with Filtration Grade
WS	Liquid Oil & Water	N/A	N/A	>90%	N/A	<70 mbar (<1 psi)	N/A	N/A
AO	Coalescing & Dry Particulate	Down to 1 micron	0.5 mg/m ³ 0.5 ppm(w)	99.925%	<70 mbar (<1 psi)	<140 mbar (<2 psi)	12 months	WS
AA	Coalescing & Dry Particulate	Down to 0.01 micron	0.01 mg/m ³ 0.01 ppm(w)	99.9999%	<140 mbar (<1.5 psi)	<200 mbar (<3 psi)	12 months	AO
ACS	Oil Vapour Reduction	N/A	0.003 mg/m ³ 0.003 ppm(w)	N/A	<140 mbar (<1.5 psi)	N/A	When oil vapour is detected	A0+AA

Important Note:

Using the same filter housings as their coalescing and dry particulate counterparts in the OIL-X IP50 range, Grade ACS filter elements differ in that they utilise a deep wrapped bed of carbon cloth to adsorb oil vapour. It is important to note, in-line adsorption filter elements have a different life span compared to coalescing and dry particulate filters and require more frequent element changes.

Technical Data

Filtration Grade	Filter Models	Minimum Operating Pressure		Maximum Operating Pressure		Minimum Operating Temperature		Maximum Operating Temperature	
		bar g	psi g	bar g	psi g	°C	°F	°C	°F
AO/AA	IP50 010 - IP50 070	20	290	50	725	2	35	100	212
ACS	IP50 010 - IP50 070	20	290	50	725	2	35	30	86

Flow Rates

Filter Coding Example

Model	Pipe Size	L/S	m ³ /min	m ³ /hr	cfm	Replacement Element	No.	Grade	Model	Pipe Size	Thread	Drain Option	Incident Monitor Option
Grade IP50 010AG X	¼"	30	1.8	108	64	K009	Grade 1	WS AO AA ACS	Cde denotes filter housing size	Letter denotes pipe size	G = BSPP	F = Automatic M = Manual	X = None
Grade IP50 020BG X	⅜"	45	2.7	162	95	K009	Grade 1						
Grade IP50 030CG X	½"	95	5.7	342	201	K030	Grade 1						
Grade IP50 040DG X	¾"	145	8.7	522	307	K030	Grade 1						
Grade IP50 050EG X	1"	285	17.1	1026	604	K145	Grade 1	Example code					
Grade IP50 060GG X	1½"	465	27.9	1674	985	K145	Grade 1	AO	IP50 010	A	G	F	X
Grade IP50 070HG X	2"	965	57.9	3473	2044	K220	Grade 1						

□ = Replace with drain type - F (Automatic) for WS water separator and AO & AA coalescing filters or M (manual) for AO & AA dry particulate and ACS oil vapour reduction filters.

Stated flows are for operation at 7 bar (g) (102 psi g) with reference to 20°C, 1 bar (a), 0% relative water vapour pressure. For flows at other pressures, apply the correction factors shown below.

Product Selection & Correction Factors

To correctly select a filter model, the flow rate of the filter must be adjusted for the minimum operating (inlet) pressure at the point of installation.

1. Obtain the minimum operating (inlet) pressure and maximum compressed air flow rate at the inlet of the filter.
2. Select the correction factor for minimum inlet pressure from the table (always round down e.g. for 33 bar, use 30 bar correction factor)
3. Calculate the minimum filtration capacity. Minimum Filtration Capacity = Compressed Air Flow Rate x CFMIP
4. Using the minimum filtration capacity, select a filter model from the flow rate tables above (filter selected must have a flow rate equal to or greater than the minimum filtration capacity).

CFMIP - Correction Factor Minimum Inlet Pressure

Minimum Inlet Pressure	bar g	20	25	30	35	40	45	50
	psi g	290	362	435	507	580	652	725
Correction Factor		2.43	1.96	1.65	1.42	1.24	1.11	1.00

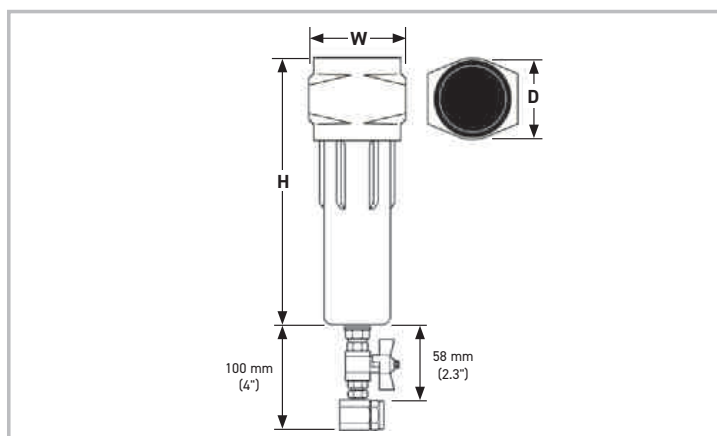

Weight & Dimensions

Model	Height (H)		Width (W)		Depth (D)		Weight	
	mm	ins	mm	ins	mm	ins	kg	lbs
IP50 010	175	6.9	78	3.1	68	2.7	1.3	2.9
IP50 020	175	6.9	78	3.1	68	2.7	1.3	2.9
IP50 030	245	9.6	89	3.5	84	3.3	2.0	4.4
IP50 040	245	9.6	89	3.5	84	3.3	2.0	4.4
IP50 050	423	16.6	122	4.8	116	4.6	5.0	11.0
IP50 060	423	16.6	122	4.8	116	4.6	5.0	11.0
IP50 070	480	18.9	170	6.7	162	6.4	10.0	22.0

Parker Catalogue Numbers

Model	Catalogue Number General Purpose Coalescing Filters	Catalogue Number General Purpose Dry Particulate Filters	Catalogue Number High Efficiency Coalescing Filters	Catalogue Number High Efficiency Dry Particulate Filters	Catalogue Number Oil Vapour Reduction Filters
IP50 010	AOIP50-010-AGFX	AOIP50-010-AGMX	AAIP50-010-AGFX	AAIP50-010-AGMX	ACSIP50-010-AGMX
IP50 020	AOIP50-020-BGFX	AOIP50-020-BGMX	AAIP50-020-BGFX	AAIP50-020-BGMX	ACSIP50-020-BGMX
IP50 030	AOIP50-030-CGFX	AOIP50-030-CGMX	AAIP50-030-CGFX	AAIP50-030-CGMX	ACSIP50-030-CGMX
IP50 040	AOIP50-040-DGFX	AOIP50-040-DGMX	AAIP50-040-DGFX	AAIP50-040-DGMX	ACSIP50-040-DGMX
IP50 050	AOIP50-050-EGFX	AOIP50-050-EGMX	AAIP50-050-EGFX	AAIP50-050-EGMX	ACSIP50-050-EGMX
IP50 060	AOIP50-060-GGFX	AOIP50-060-GGMX	AAIP50-060-GGFX	AAIP50-060-GGMX	ACSIP50-060-GGMX
IP50 070	AOIP50-070-HGFX	AOIP50-070-HGMX	AAIP50-070-HGFX	AAIP50-070-HGMX	ACSIP50-070-HGMX

SPH - 50 Bar Refrigeration Dryers

Dryer Performance

Dryer Models	Dewpoint (Standard)		Dewpoint (Option 1)		Dewpoint (Option 2)	
	°C	°F	°C	°F	°C	°F
SPH	+3	-37	+7	+45	+10	+50

Technical Data

Dryer Models	Minimum Operating Pressure		Maximum Operating Pressure		Minimum Operating Temperature		Maximum Operating Temperature		Maximum Ambient Temperature		Electrical Supply (Standard)	Electrical Supply (Optional)	Thread Connections	Noise Level dB(A)
	bar g	psi g	bar g	psi g	°C	°F	°C	°F	°C	°F				
SPH 004 - SPH 018	2	29	50	725	5	41	65	149	50	122	230V 1ph 50Hz	60Hz on request	BSPT-F	<55

Flow Rates

Model	Pipe Size BSPG or NPT	Inlet Flow Rate				Absorbed Power kW
		L/s	m³/min	m³/hr	cfm	
SPH 004	½"	7	0.4	25	15	0.17
SPH 006	½"	10	0.6	37	22	0.17
SPH 012	½"	21	1.3	75	44	0.25
SPH 018	½"	36	2.2	131	77	0.57

Performances refer to air-cooled model with air suction of FAD 20°C / 1 bar A, and at the following operating conditions: air suction 25°C / 60%RH, 40 barg working pressure, 25°C cooling air temperature, 35°C compressed air inlet temperature and pressure dewpoint in accordance with ISO8573-1. All indicated data refers to DIN ISO 7183. SPH supplied with refrigerant R134a. All models designed for operation up to 50 barg. Data refers to 50Hz models.

Product Selection & Correction Factors

For correct operation, compressed air dryers must be sized using for the maximum (summer) inlet temperature, maximum (summer) ambient temperature, minimum inlet pressure, required outlet dewpoint and maximum flow rate of the installation.

To select a dryer, first calculate the MDC (Minimum Drying Capacity) using the formula below then select a dryer from the flow rate table above with a flow rate equal to or above the MDC.

$$\text{Minimum Drying Capacity} = \text{System Flow} \times \text{CFMIT} \times \text{CFMAT} \times \text{CFMIP} \times \text{CFOD}$$

CFMIT - Correction Factor Maximum Inlet Temperature

Maximum Inlet Temperature	°C	25	30	35	40	45	50	55	60	65
	°F	77	86	95	104	113	122	131	140	149
Correction Factor		0.85	0.85	1.00	1.15	1.30	1.45	1.61	1.79	2.00

CFMAT - Correction Factor Maximum Ambient Temperature

Maximum Ambient Temperature	°C	20	25	30	35	40	45	50
	°F	68	77	80	95	104	113	122
Correction Factor		0.98	1.00	1.02	1.05	1.08	1.11	1.16

CFMIP - Correction Factor Minimum Inlet Pressure

Minimum Inlet Pressure	bar g	15	20	25	30	35	40	45	50
	psi g	218	290	363	435	508	580	653	725
Correction Factor		1.18	1.10	1.06	1.03	1.01	1.00	0.99	0.99

CFOD - Correction Factor Outlet Dewpoint

Outlet Dewpoint	°C	+3	+5	+7	+10
	°F	+37	+41	+45	+50
Correction Factor		1.00	0.86	0.80	0.71

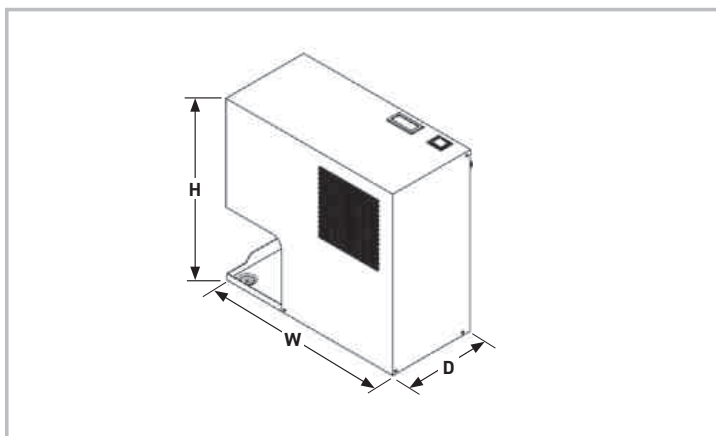

Weights & Dimensions

Model	Dimensions						Weight	
	Height (H)		Width (W)		Depth (D)			
	mm	ins	mm	ins	mm	ins	kg	lbs
SPH 004	430	16.93	450	17.7	210	8.3	19	42
SPH 006	430	16.93	450	17.7	210	8.3	19	42
SPH 012	600	23.6	555	21.9	425	16.7	40	88
SPH 018	600	23.6	555	21.9	425	16.7	42.5	94

Recommended Filtration

Pipe Size BSSP	Dryer Inlet	Dryer Outlet
	General Purpose Pre-Filter	High Efficiency Post Filter
1/2"	G2/50ZP	G2/50XP
1/2"	G2/50ZP	G2/50XP
1/2"	G3/50ZP	G3/50XP
1/2"	G5/50ZP	G5/50XP

Parker Catalogue Numbers

Model	Catalogue Number
SPH 004	SPH004-A23015050TXS
SPH 006	SPH006-A23015050TXS
SPH 012	SPH012-A23015050TXS
SPH 018	SPH018-A23015050TXS

PSH - 50 Bar Refrigeration Dryers

Dryer Performance

Dryer Models	Dewpoint (Standard)		Dewpoint (Option 1)		Dewpoint (Option 2)	
	°C	°F	°C	°F	°C	°F
PSH	+3	-37	+7	+45	+10	+50

Technical Data

Dryer Models	Minimum Operating Pressure		Maximum Operating Pressure		Minimum Operating Temperature		Maximum Operating Temperature		Maximum Ambient Temperature		Electrical Supply (Standard)	Electrical Supply (Optional)	Thread Connections	Noise Level dB(A)
	bar g	psi g	bar g	psi g	°C	°F	°C	°F	°C	°F				
PSH 030 - 090	2	29	50	725	5	41	65	149	50	122	230V 1ph 50Hz	60Hz on request	BSPT-F	<55
PSH 0120 - 1200	2	29	50	725	5	41	65	149	50	122	400V 3ph 50Hz	60Hz on request	BSPT-F & 2½" Flange	<58

Flow Rates

Model	Pipe Size BSPP or NPT	Inlet Flow Rate				Absorbed Power kW
		L/s	m³/min	m³/hr	cfm	
PSH030	1¼"	50	3.0	180	106	0.53
PSH045	1¼"	75	4.5	270	159	0.55
PSH065	1¼"	108	6.5	390	230	1.33
PSH090	1¼"	150	9	540	318	1.37
PSH120	1¼"	200	12	720	424	1.41
PSH160	1¼"	267	16	960	565	1.44
PSH200	1¼"	333	20	1200	706	1.47
PSH230	1¼"	383	23	1380	812	1.52
PSH290	2½" ANSI	483	29	1740	1024	2.89
PSH380	2½" ANSI	633	38	2280	1342	3.18
PSH460	2½" ANSI	767	46	2760	1625	3.44
PSH630	2½" ANSI	1050	63	3780	2225	4.12
PSH800	2½" ANSI	1333	80	4800	2825	6.60
PSH1000	2½" ANSI	1667	100	6000	3531	6.90
PSH1200	2½" ANSI	2000	120	7200	4238	7.30

Performances refer to air-cooled model with air suction of FAD 20°C / 1 bar A, and at the following operating conditions: air suction 25°C / 60%RH, 40 barg working pressure, 25°C cooling air temperature, 35°C compressed air inlet temperature and pressure and pressure dewpoint in accordance with ISO8573-1. All indicated data refers to DIN ISO 7183. PSH supplied with refrigerant R407c. All models designed for operation up to 50 barg. Data refers to 50Hz models.

Product Selection & Correction Factors

For correct operation, compressed air dryers must be sized using for the maximum (summer) inlet temperature, maximum (summer) ambient temperature, minimum inlet pressure, required outlet dewpoint and maximum flow rate of the installation.

To select a dryer, first calculate the MDC (Minimum Drying Capacity) using the formula below then select a dryer from the flow rate table above with a flow rate equal to or above the MDC.

$$\text{Minimum Drying Capacity} = \text{System Flow} \times \text{CFMIT} \times \text{CFMAT} \times \text{CFMIP} \times \text{CFOD}$$

CFMIT - Correction Factor Maximum Inlet Temperature

Maximum Inlet Temperature	°C	25	30	35	40	45	50	55	60	65
	°F	77	86	95	104	113	122	131	140	149
Correction Factor		0.85	0.85	1.00	1.15	1.30	1.45	1.61	1.79	2.00

CFMAT - Correction Factor Maximum Ambient Temperature

Maximum Ambient Temperature	°C	20	25	30	35	40	45	50
	°F	68	77	80	95	104	113	122
Correction Factor		0.98	1.00	1.02	1.05	1.08	1.11	1.16

CFMIP - Correction Factor Minimum Inlet Pressure

Minimum Inlet Pressure	bar g	15	20	25	30	35	40	45	50
	psi g	218	290	363	435	508	580	653	725
Correction Factor		1.18	1.10	1.06	1.03	1.01	1.00	0.99	0.99

CFOD - Correction Factor Outlet Dewpoint

Outlet Dewpoint	°C	+3	+5	+7	+10
	°F	+37	+41	+45	+50
Correction Factor		1.00	0.86	0.80	0.71

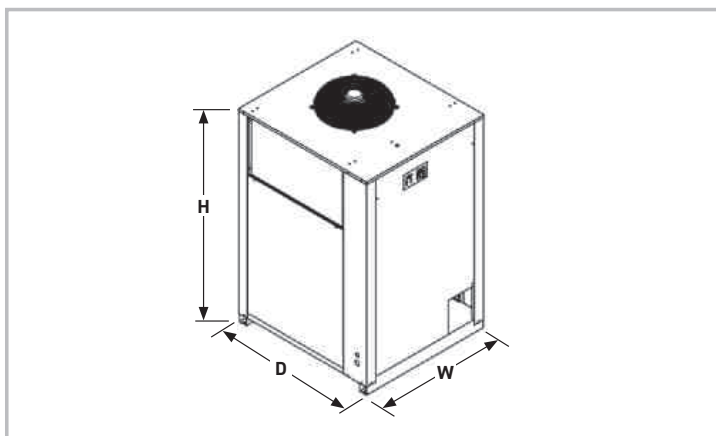

Weights & Dimensions

Model	Dimensions						Weight	
	Height (H)		Width (W)		Depth (D)			
	mm	ins	mm	ins	mm	ins	kg	lbs
PSH030	945	37.2	703	27.68	562	22.13	83	183
PSH045	945	37.2	703	27.68	562	22.13	83	183
PSH065	945	37.2	703	27.68	562	22.13	85	187
PSH090	945	37.2	703	27.68	562	22.13	85	187
PSH120	1064	41.89	706	27.8	1046	41.18	152	335
PSH160	1064	41.89	706	27.8	1046	41.18	152	335
PSH200	1064	41.89	706	27.8	1046	41.18	152	335
PSH230	1064	41.89	706	27.8	1046	41.18	152	335
PSH290	1690	66.54	1007	39.65	1097	43.19	356	785
PSH380	1690	66.54	1007	39.65	1097	43.19	356	785
PSH460	1690	66.54	1007	39.65	1097	43.19	356	785
PSH630	1690	66.54	1007	39.65	1657	65.24	455	1003
PSH800	1723	67.83	1007	39.65	1657	65.24	610	1345
PSH1000	1723	67.83	1007	39.65	1657	65.24	610	1345
PSH1200	1723	67.83	1007	39.65	1657	65.24	610	1345

Recommended Filtration

Pipe Size BSPP	Dryer Inlet	Dryer Outlet
	General Purpose Pre-Filter	High Efficiency Post Filter
1½"	G7/50ZP	G7/50XP
1½"	G9/50ZP	G9/50XP
1½"	G11/50ZP	G11/50XP
1½"	G11/50ZP	G11/50XP
1½"	G12/50ZP	G12/50XP
1½"	G13/50ZP	G13/50XP
1½"	G13/50ZP	G13/50XP
1½"	G13/50ZP	G13/50XP
	Contact Parker	
	Contact Parker	
	Contact Parker	
	Contact Parker	
	Contact Parker	
	Contact Parker	
	Contact Parker	

Parker Catalogue Numbers

Model	Catalogue Number 50Hz Air Cooled	Catalogue Number 50Hz Water Cooled
PSH030	PSH030-A23015050TI	N/A
PSH045	PSH045-A23015050TI	N/A
PSH065	PSH065-A23015050TI	N/A
PSH090	PSH090-A23015050TI	N/A
PSH120	PSH120-A40035050TI	N/A
PSH160	PSH160-A40035050TI	N/A
PSH200	PSH200-A40035050TI	N/A
PSH230	PSH230-A40035050TI	N/A
PSH290	PSH290-A40035050TI	PSH290-W40035050TI
PSH380	PSH380-A40035050TI	PSH380-W40035050TI
PSH460	PSH460-A40035050TI	PSH460-W40035050TI
PSH630	PSH630-A40035050TI	PSH630-W40035050TI
PSH800	PSH800-A40035050TI	PSH800-W40035050TI
PSH1000	PSH1000-A40035050TI	PSH1000-W40035050TI
PSH1200	PSH1200-A40035050TI	PSH1200-W40035050TI

GH - 350 Bar Compressed Air Filters

Filtration Performance

Filtration Grade	Filter Type	Particle Reduction (inc water & oil aerosols)	Max Remaining Oil Content at 21°C (70°F)	Filtration Efficiency	Initial Dry Differential Pressure	Initial Saturated Differential Pressure	Change Element Every	Precede with Filtration Grade
V	Dry Particulate	Down to 3 micron	N/A	>90%	<300 mbar (<4.35 psi)	<350 mbar (<5 psi)	12 months or 6000 hours	N/A
ZP	Coalescing & Dry Particulate	Down to 1 micron	0.5 mg/m ³ 0.5 ppm(w)	99.925%	<300 mbar (<4.35 psi)	<370 mbar (<5.4 psi)	12 months or 6000 hours	N/A
XP	Coalescing & Dry Particulate	Down to 0.01 micron	0.01 mg/m ³ 0.01 ppm(w)	99.9999%	<300 mbar (<4.35 psi)	<400 mbar (<5.8 psi)	12 months or 6000 hours	ZP
A	Oil Vapour Reduction	N/A	0.003 mg/m ³ 0.003 ppm(w)	N/A	<300 mbar (<4.35 psi)	N/A	When oil vapour is detected	ZP+XP

Important Note:

Using the same filter housings as their coalescing and dry particulate counterparts, Grade A filter elements differ in that they utilise a bed of activated carbon to adsorb oil vapour. It is important to note, in-line adsorption filter elements have a different life span compared to coalescing and dry particulate filters and require more frequent element changes.

Technical Data

Filtration Grade	Filter Models	Minimum Operating Pressure		Maximum Operating Pressure		Minimum Operating Temperature		Maximum Operating Temperature	
		bar g	psi g	bar g	psi g	°C	°F	°C	°F
V/ZP/XP	GH3350 - GH13350	50	725	350	5076	2	35	80	176
A	GH3350 - GH13350	50	725	350	5076	2	35	50	122

Flow Rates

Model	Pipe Size	L/S	m ³ /min	m ³ /hr	cfm	Replacement Element	No.
GH3350	Grade ½"	101	6.1	365	215	1050	1
GH5350	Grade ½"	139	8.4	501	295	1070	1
GH7350	Grade ½"	215	12.9	776	457	1140	1
GH9350	Grade ½"	287	17.3	1035	609	2010	1
GH11350	Grade 1"	514	30.9	1852	1090	2020	1
GH12350	Grade 1½"	782	46.9	2816	1657	2030	1
GH13350	Grade 1½"	1184	71.0	4261	2508	2050	1

Filter Coding Example

Grade	Model
XP	GH3350XP

Stated flows are for operation at 7 bar (g) (102 psi g) with reference to 20°C, 1 bar (a), 0% relative water vapour pressure. For flows at other pressures, apply the correction factors shown below.

Product Selection & Correction Factors

To correctly select a filter model, the flow rate of the filter must be adjusted for the minimum operating (inlet) pressure at the point of installation.

1. Obtain the minimum operating (inlet) pressure and maximum compressed air flow rate at the inlet of the filter.
2. Select the correction factor for minimum inlet pressure from the CFMIP table (always round down e.g. for 155 bar, use 150 bar correction factor)
3. Calculate the minimum filtration capacity. Minimum Filtration Capacity = Compressed Air Flow Rate x CFMIP
4. Using the minimum filtration capacity, select a filter model from the flow rate tables above (filter selected must have a flow rate equal to or greater than the minimum filtration capacity).

CFMIP - Correction Factor Minimum Inlet Pressure

Minimum Inlet Pressure	bar g	50	60	70	80	90	100	125	150	175	200	225	250	275	300	325	350
	psi g	725	870	1015	1160	1305	1450	1813	2175	2538	2901	3263	3626	3989	4351	4714	5076
Correction Factor		2.65	2.42	2.24	2.09	1.97	1.87	1.67	1.53	1.41	1.32	1.25	1.18	1.13	1.08	1.04	1.00

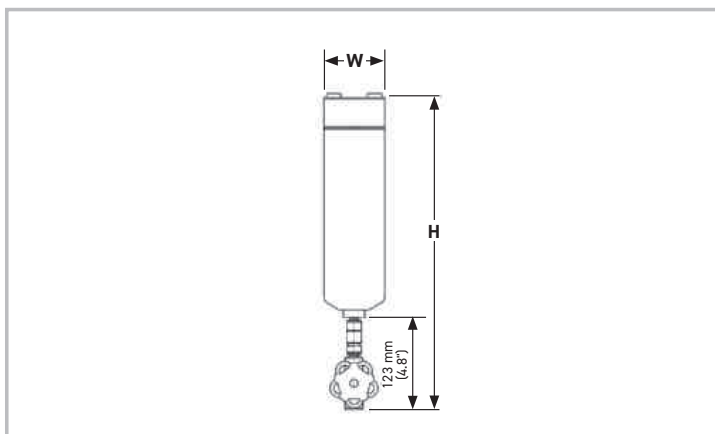

Weights & Dimensions

Model	Height (H)		Width (W)		Depth (D)		Weight	
	mm	ins	mm	ins	mm	ins	kg	lbs
GH3350	355	14.0	80	3.1	80	3.1	2.8	6.2
GH5350	355	14.0	80	3.1	80	3.1	2.8	6.2
GH7350	420	16.5	80	3.1	80	3.1	3.4	7.5
GH9350	455	17.9	116	4.6	116	4.6	18.2	40.1
GH11350	540	21.3	116	4.6	116	4.6	21.9	48.3
GH12350	655	25.8	125	4.9	125	4.9	28.3	62.4
GH13350	910	35.8	125	4.9	125	4.9	39.2	86.4

Parker Catalogue Numbers

Model	Catalogue Number 3 Micron Pre-Filters	Catalogue Number General Purpose Filters	Catalogue Number High Efficiency Filters	Catalogue Number Oil Vapour Reduction Filters
GH3350	GH3/350V	GH3/350ZP	GH3/350XP	GH3/350A
GH5350	GH5/350V	GH5/350ZP	GH5/350XP	GH5/350A
GH7350	GH7/350V	GH7/350ZP	GH7/350XP	GH7/350A
GH9350	GH9/350V	GH9/350ZP	GH9/350XP	GH9/350A
GH11350	GH11/350V	GH11/350ZP	GH11/350XP	GH11/350A
GH12350	GH12/350V	GH12/350ZP	GH12/350XP	GH12/350A
GH13350	GH13/350V	GH13/350ZP	GH13/350XP	GH13/350A

HDK-MT - 350 Bar Compressed Air Dryers

Dryer Performance

Dryer Models	Dewpoint (Standard)		ISO8573-1:2010 Classification (Standard)	Dewpoint (Option 1)		ISO8573-1:2010 Classification (Option 1)
	°C	°F		°C	°F	
HDK-MT 15 - 70	-40	-40	Class 2.2.2	-20	-4	Class 2.3.2

Technical Data

Dryer Models	Minimum Operating Pressure		Maximum Operating Pressure		Minimum Operating Temperature		Maximum Operating Temperature		Maximum Ambient Temperature		Electrical Supply (Standard)	Electrical Supply (Optional)	Thread Type	Noise Level
	bar g	psi g	bar g	psi g	°C	°F	°C	°F	°C	°F				dB(A)
HDK-MT 15 - 70	100	1450	350	5076	5	41	55	131	50	122	230V 1ph 50/60Hz	115V 1ph 50/60Hz	BSPP	95-115

Flow Rates

Model	Pipe Size BSPP	Inlet Flow Rate			
		L/s	m³/min	m³/hr	cfm
HDK-MT 15/350	G½	56	3.3	200	118
HDK-MT 20/350	G½	83	5.0	300	177
HDK-MT 23/350	G½	111	6.7	400	235
HDK-MT 30/350	G½	139	8.4	500	294
HDK-MT 40/350	G¾	217	13	780	459
HDK-MT 50/350	G¾	261	16	940	553
HDK-MT 70/350	G¾	328	20	1180	695

Stated flows are for operation at 7 bar (g) (102 psi g) with reference to 20°C, 1 bar (a), 0% relative water vapour pressure. For flows at other pressures, apply the correction factors shown below.

Product Selection & Correction Factors

For correct operation, compressed air dryers must be sized using for the maximum (summer) inlet temperature, maximum (summer) ambient temperature, minimum inlet pressure, required outlet dewpoint and maximum flow rate of the installation.

To select a dryer, first calculate the MDC (Minimum Drying Capacity) using the formula below then select a dryer from the flow rate table above with a flow rate equal to or above the MDC.

$$\text{Minimum Drying Capacity} = \text{System Flow} \times \text{CFIT} \times \text{CFAT} \times \text{CFMIP} \times \text{CFOD}$$

CFMIT - Correction Factor Maximum Inlet Temperature

Maximum Inlet Temperature	°C	30	35	40	45	50	55
	°F	86	95	104	113	122	131
Correction Factor		1.00	1.00	1.32	1.68	2.15	2.8

CFMAT - Correction Factor Maximum Ambient Temperature

Maximum Ambient Temperature	°C	25	30	35	40	45	50
	°F	77	86	95	104	113	122
Correction Factor		1.00	1.00	1.00	1.00	1.00	1.00

CFMIP - Correction Factor Minimum Inlet Pressure

Minimum Inlet Pressure	bar g	100	150	200	250	300	350
	psi g	1450	2175	2900	3625	4351	5076
Correction Factor		3.57	2.33	1.75	1.41	1.16	1.00

CFOD - Correction Factor Outlet Dewpoint

Outlet Dewpoint	°C	-20	-40	-70
	°F	-4	-40	-100
Correction Factor		1.00	1.00	N/A

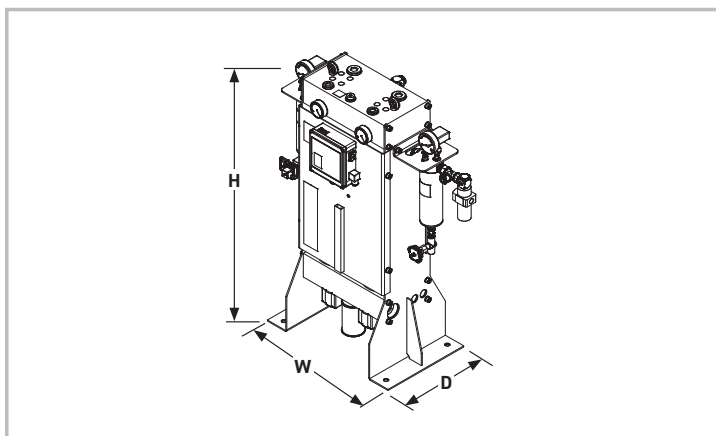

Weights & Dimensions

Model	Pipe Size BSPP	Dimensions						Weight	
		Height (H)		Width (W)		Depth (D)		kg	lbs
		mm	ins	mm	ins	mm	ins		
HDK-MT 15/350	G½	1050	41.3	700	27.6	370	14.6	190	86
HDK-MT 20/350	G½	1250	49.2	700	27.6	370	14.6	220	100
HDK-MT 23/350	G½	1450	57.1	700	27.6	370	14.6	250	114
HDK-MT 30/350	G½	1650	65.0	700	27.6	370	14.6	280	127
HDK-MT 40/350	G¾	1650	65.0	770	30.3	370	14.6	310	141
HDK-MT 50/350	G¾	1850	72.8	770	30.3	450	17.7	340	155
HDK-MT 70/350	G¾	2075	81.7	770	30.3	450	17.7	380	173

Required Filtration

Model	Pipe Size BSPP or NPT	Dryer Inlet	
		General Purpose Pre-filter	
HDK-MT 15/350	G½	GH7/350ZP	
HDK-MT 20/350	G½	GH7/350ZP	
HDK-MT 23/350	G½	GH7/350ZP	
HDK-MT 30/350	G½	GH7/350ZP	
HDK-MT 40/350	G¾	GH9/350ZP	
HDK-MT 50/350	G¾	GH9/350ZP	
HDK-MT 70/350	G¾	GH9/350ZP	

Included Filtration

Dryer Inlet	Dryer Outlet			
	High Efficiency Filter	Oil Vapour Reduction Filter	General Purpose Dry Particulate Filter	High Efficiency Dry Particulate Filter
GH7/350XP	-	-	GH7/350ZP/VV	-
GH7/350XP	-	-	GH7/350ZP/VV	-
GH7/350XP	-	-	GH7/350ZP/VV	-
GH7/350XP	-	-	GH7/350ZP/VV	-
GH9/350XP	-	-	GH9/350ZP/VV	-
GH9/350XP	-	-	GH9/350ZP/VV	-
GH9/350XP	-	-	GH9/350ZP/VV	-

BAC-4015 Breathable Compressed Air Purifier

Performance

Model	Dewpoint (Standard)		ISO8573-1:2010 Classification (Standard)
	°C	°F	
BAC-4015	-40	-40	Class 1.2.1

Technical Data

Model	Minimum Operating Pressure		Maximum Operating Pressure		Minimum Operating Temperature		Maximum Operating Temperature		Maximum Ambient Temperature		Electrical Supply (Standard)	Thread Type	Noise Level
	bar g	psi g	bar g	psi g	°C	°F	°C	°F	°C	°F			dB(A)
BAC-4015	4	58	10	145	5	41	30	86	55	131	Fully Pneumatic	BSPP	<75

Flow Rates

Model	Pipe Size		Inlet Flow Rate				Regeneration Air Requirement			
	Inlet	Outlet	L/s	m³/min	m³/hr	cfm	L/s	m³/min	m³/hr	cfm
BAC-4015	G½	G¼	11	0.68	41	24	2.36	0.14	8.5	5

Stated flows are for operation at 7 bar (g) (102 psi g) with reference to 20°C, 1 bar (a), 0% relative water vapour pressure. For flows at other conditions, apply the correction factors shown below.

Product Selection & Correction Factors

For correct operation, breathing air purifiers must be sized using for the maximum (summer) inlet temperature, minimum inlet pressure, and maximum flow rate of the installation.

To select a breathing air purifier, first calculate the MPC (Minimum Purification Capacity) using the formula below then select a breathing air purifier from the flow rate table above with a flow rate equal to or above the MPC.

Minimum Purification Capacity = System Flow x CFMIT x CFMIP

CFMIT - Correction Factor Maximum Inlet Temperature

Maximum Inlet Temperature	°C	25	30
	°F	77	86
Correction Factor		1.00	1.20

CFMIP - Correction Factor Minimum Inlet Pressure

Minimum Inlet Pressure	bar g	4	5	6	7	8	9	10
	psi g	58	73	87	100	116	131	145
Correction Factor		1.60	1.33	1.14	1.00	0.89	0.80	0.73

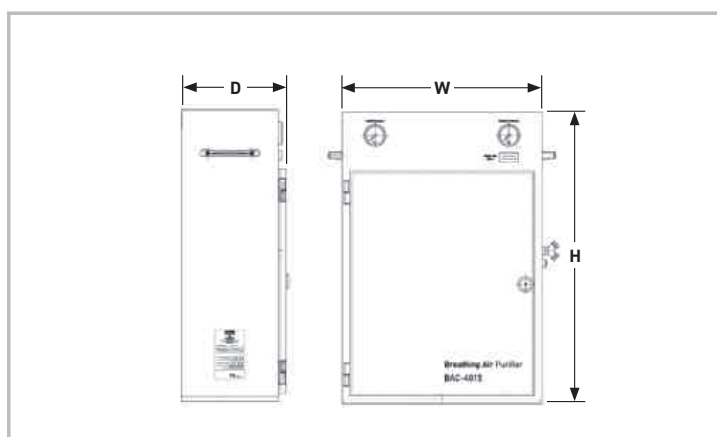

Weights & Dimensions

Model	Pipe Size BSPP		Dimensions						Weight	
			Height (H)		Width (W)		Depth (D)			
	Inlet	Outlet	mm	ins	mm	ins	mm	ins	kg	lbs
BAC-4015	G½	G¼	752	29.6	515	20.3	272	10.7	40	88.2

Included Filtration

Model	Dryer Inlet			Dryer Outlet	
	General Purpose Pre-filter	High Efficiency Filter	Oil Vapour Reduction Filter	General Purpose Dry Particulate Filter	High Efficiency Dry Particulate Filter
BAC-4015		•	•		•

Filtration Performance	General Purpose Pre-filter	High Efficiency Filter	Oil Vapour Reduction Filter	General Purpose Dry Particulate Filter	High Efficiency Dry Particulate Filter
Filtration Grade	-	Grade AA	AC	-	Grade AA
Filtration Type	-	Coalescing	Adsorption	-	Coalescing
Particle Reduction (inc water & oil aerosols)	-	Down to 0.01 micron	N/A	-	Down to 0.01 micron
Maximum Remaining Oil Aerosol Content at 21°C	-	≤0.01 mg/m ³ (≤0.01 ppm(w))	N/A	-	N/A
Maximum Remaining Oil Vapour Content at System Temperature	-	N/A	≤0.003 mg/m ³ (≤0.003 ppm(w))	-	N/A
Filtration Efficiency	-	99.9999%	N/A	-	99.9999%

Quality Assurance / IP Rating / Pressure Vessel Approvals

Development / Manufacture	ISO 9001 / ISO 14001
Ingress Protection Rating	IP55 Indoor Use Only
EU	Pressure vessel approved for fluid group 2 in accordance with the Pressure Equipment Directive 2014/68/EU
USA	Approval to ASME VIII Div. 1 not required
AUS	Approval to AS1210 not required
GUS	TR (formerly GOST-R)
For use with compressed air only	

BA-DME Breathable Compressed Air Purifier

Performance

Models	Dewpoint (Standard)		ISO8573-1:2010 Classification (Standard)
	°C	°F	
BA-DME	-40	-40	Class 1.2.1

Technical Data

Models	Minimum Operating Pressure		Maximum Operating Pressure		Minimum Operating Temperature		Maximum Operating Temperature		Maximum Ambient Temperature		Electrical Supply (Standard)	Thread Type	Noise Level dB(A)
	bar g	psi g	bar g	psi g	°C	°F	°C	°F	°C	°F			
BA-DME012E - BA-DME040E	4	58	16	232	5	41	30	86	55	131	230V / 1ph / 50-60Hz	BSPP	<75
BA-DME050E - BA-DME080E			13	189									

Flow Rates

Model	Pipe Size		Inlet Flow Rate				Regeneration Air Requirement			
	Inlet	Outlet	L/s	m³/min	m³/hr	cfm	L/s	m³/min	m³/hr	cfm
BA-DME012E	G½	G¾	11	0.68	41	24	2	0.14	8	5
BA-DME015E	G½	G¾	15	0.92	55	32	3	0.18	11	6
BA-DME020E	G½	G¾	20	1.19	71	42	4	0.24	14	8
BA-DME025E	G½	G¾	25	1.50	90	53	5	0.30	18	11
BA-DME030E	G½	G¾	31	1.84	110	65	6	0.37	22	13
BA-DME040E	G¾	G¾	41	2.49	149	88	8	0.50	30	18
BA-DME050E	G1	G1	50	3.01	180	106	10	0.60	36	21
BA-DME060E	G1	G1	61	3.69	221	130	12	0.74	44	26
BA-DME080E	G1	G1	83	4.99	299	176	17	1.00	60	35

Stated flows are for operation at 7 bar (g) (102 psi g) with reference to 20°C, 1 bar (a), 0% relative water vapour pressure. For flows at other conditions, apply the correction factors shown below.

Product Selection & Correction Factors

For correct operation, breathing air purifiers must be sized using for the maximum (summer) inlet temperature, minimum inlet pressure required and maximum flow rate of the installation.

To select a breathing air purifier, first calculate the MPC (Minimum Purification Capacity) using the formula below then select a breathing air purifier from the flow rate table above with a flow rate equal to or above the MPC.

Minimum Purification Capacity = System Flow x CFMIT x CFMIP

CFMIT - Correction Factor Maximum Inlet Temperature

Maximum Inlet Temperature	°C	25	30
	°F	77	86
Correction Factor		1.00	1.20

CFMIP - Correction Factor Minimum Inlet Pressure

Minimum Inlet Pressure	bar g	4	5	6	7	8	9	10	11	12	13	14	15	1613
	psi g	58	73	87	100	116	131	145	160	174	189	203	218	232
Correction Factor		1.60	1.33	1.14	1.00	0.89	0.80	0.73	0.67	0.62	0.57	0.54	0.50	0.47

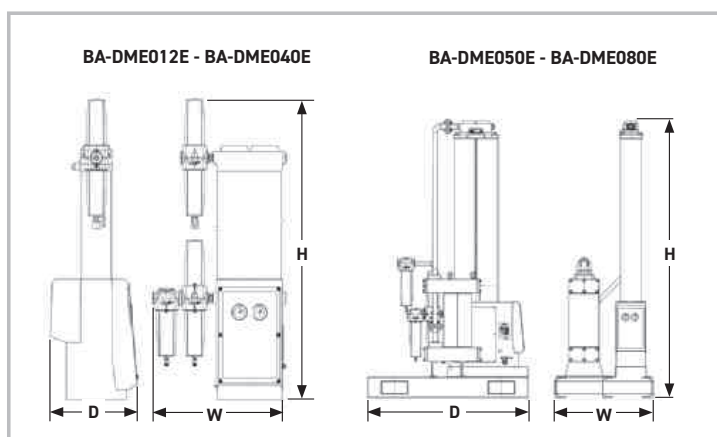

Weights & Dimensions

Model	Pipe Size		Dimensions						Weight	
	Inlet	Outlet	Height (H)		Width (W)		Depth (D)			
			mm	ins	mm	ins	mm	ins	kg	lbs
BA-DME012E	G½	G¾	1000	93.4	578	22.8	302	12	37	81.5
BA-DME015E	G½	G¾	1197	47.1	480	18.9	302	12	42	93
BA-DME020E	G½	G¾	1326	52.2	480	18.9	302	12	47	104
BA-DME025E	G½	G¾	1527	60.1	480	18.9	302	12	52	115
BA-DME030E	G½	G¾	1693	66.7	511	20.1	302	12	57	126
BA-DME040E	G½	G¾	1941	76.4	545	21.5	302	12	74	163
BA-DME050E	G1	G1	1699	66.9	400	15.8	1200	47.2	210	463
BA-DME060E	G1	G1	1831	72.1	400	15.8	1200	47.2	222	490
BA-DME080E	G1	G1	2076	81.7	745	29.3	1200	47.2	279	615

Included Filtration

Models	Dryer Inlet			Dryer Outlet	
	General Purpose Pre-filter	High Efficiency Filter	Oil Vapour Reduction Filter	General Purpose Dry Particulate Filter	High Efficiency Dry Particulate Filter
BA-DME012E ~ BA-DME080E	•	•	•		•
Filtration Performance	General Purpose Pre-filter	High Efficiency Filter	Oil Vapour Reduction Filter	General Purpose Dry Particulate Filter	High Efficiency Dry Particulate Filter
Filtration Grade	Grade AO	Grade AA	AC	-	Grade AA
Filtration Type	Coalescing	Coalescing	Adsorption	-	Coalescing
Particle Reduction (inc water & oil aerosols)	Down to 1 micron	Down to 0.01 micron	N/A	-	Down to 0.01 micron
Maximum Remaining Oil Aerosol Content at 21°C	≤0.5 mg/m³ (≤0.5 ppm(w))	≤0.01 mg/m³ (≤0.01 ppm(w))	N/A	-	N/A
Maximum Remaining Oil Vapour Content at System Temperature	N/A	N/A	≤0.003 mg/m³ (≤0.003 ppm(w))	-	N/A
Filtration Efficiency	99.925%	99.9999%	N/A	-	99.9999%

Quality Assurance / IP Rating / Pressure Vessel Approvals

Development / Manufacture	ISO 9001 / ISO 14001
Ingress Protection Rating	IP55 Indoor Use Only
EU	Pressure vessel approved for fluid group 2 in accordance with the Pressure Equipment Directive 2014/68/EU
USA	Approval to ASME VIII Div. 1 not required
AUS	Approval to AS1210 not required
GUS	TR (formerly GOST-R)
For use with compressed air only	

BSP-MT 1-8 Breathable Compressed Air Purifier

Performance

Models	Dewpoint (Standard)		ISO8573-1:2010 Classification (Standard)
	°C	°F	
BSP-MT 1-8	-40	-40	Class 2.2.1

Technical Data

Models	Minimum Operating Pressure		Maximum Operating Pressure		Minimum Operating Temperature		Maximum Operating Temperature		Maximum Ambient Temperature		Electrical Supply (Standard)	Electrical Supply (Option)	Thread Type	Noise Level dB(A)
	bar g	psi g	bar g	psi g	°C	°F	°C	°F	°C	°F				
BSP-MT 1-8	5	73	16	232	5	41	50	122	50	122	230V / 1ph / 50-60Hz	115V / 1ph / 50-60Hz	BSPP	<75

Flow Rates

Model	Pipe Size	Flow Rate				Regeneration Air Requirement			
		L/s	m³/min	m³/hr	cfm	L/s	m³/min	m³/hr	cfm
BSP-MT 1	G¼	4	0.22	13	8	0.7	0.04	2.6	2
BSP-MT 2	G¼	7	0.40	24	14	1.3	0.08	4.8	3
BSP-MT 3	G¼	11	0.67	40	24	2.2	0.13	8	5
BSP-MT 4	G¼	16	0.94	56	33	3.1	0.19	11.2	7
BSP-MT 6	G½	25	1.50	90	53	5.0	0.30	18	11
BSP-MT 7	G½	32	1.94	116	68	6.4	0.39	23.2	14
BSP-MT 8	G½	39	2.32	139	82	7.7	0.46	27.8	16

Stated flows are for operation at 13 bar (g) (189 psi g), 35°C (95°F) with reference to 20°C, 1 bar (a), 0% relative water vapour pressure. For flows at other conditions, apply the correction factors shown below.

Product Selection & Correction Factors

For correct operation, breathing air purifiers must be sized for the maximum (summer) inlet temperature, minimum inlet pressure and maximum flow rate of the installation.

To select a breathing air purifier, first calculate the MPC (Minimum Purification Capacity) using the formula below then select a breathing air purifier from the flow rate table above with a flow rate equal to or above the MPC.

Minimum Purification Capacity = System Flow x Correction Factor

Minimum Inlet Pressure bar g (psi g)	Inlet temperature in °C (°F)					
	25 (77)	30 (86)	35 (95)	40 (104)	45 (113)	50 (122)
5 (73)	2.13	2.17	2.27	2.50	2.78	2.94
6 (87)	1.82	1.85	1.92	2.22	2.50	2.63
7 (102)	1.59	1.61	1.67	2.00	2.27	2.33
8 (116)	1.39	1.43	1.47	1.67	1.85	1.92
9 (131)	1.27	1.28	1.33	1.59	1.67	1.82
10 (145)	1.15	1.16	1.25	1.54	1.59	1.64
11 (160)	1.25	1.27	1.33	1.56	1.64	1.69
12 (174)	1.09	1.10	1.12	1.28	1.37	1.49
13 (189)	0.97	0.98	1.00	1.10	1.22	1.27
14 (203)	0.86	0.87	0.88	1.00	1.06	1.16
15 (218)	0.77	0.78	0.79	0.93	0.97	1.01

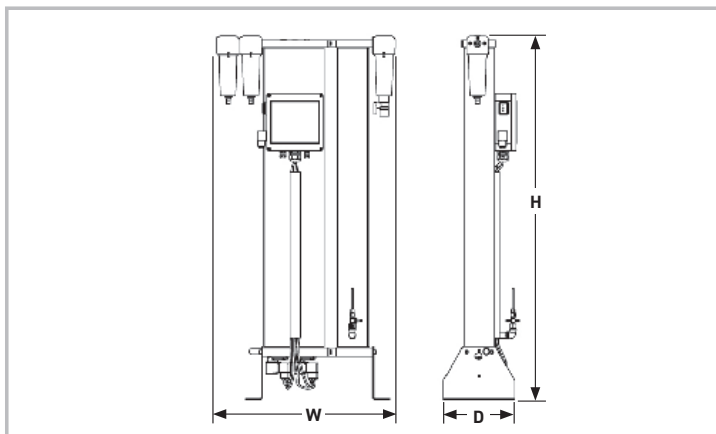

Weights & Dimensions

Model	Pipe Size	Dimensions						Weight	
		Height (H)		Width (W)		Depth (D)			
		mm	ins	mm	ins	mm	ins	kg	lbs
BSP-MT 1	G $\frac{1}{4}$	400	15.7	533	21.0	216	8.5	17	36
BSP-MT 2	G $\frac{1}{4}$	575	22.6	533	21.0	216	8.5	22	47
BSP-MT 3	G $\frac{1}{4}$	825	32.5	533	21.0	216	8.5	29	64
BSP-MT 4	G $\frac{1}{4}$	1075	42.3	533	21.0	216	8.5	36	79
BSP-MT 6	G $\frac{1}{2}$	1203	47.4	736	29.0	300	11.8	75	165
BSP-MT 7	G $\frac{1}{2}$	1428	56.2	736	29.0	300	11.8	85	187
BSP-MT 8	G $\frac{1}{2}$	1628	64.1	736	29.0	300	11.8	97	214

Included Filtration

Models	Dryer Inlet		Dryer Outlet		
	General Purpose Pre-filter	High Efficiency Filter	Oil Vapour Reduction Filter	General Purpose Dry Particulate Filter	High Efficiency Dry Particulate Filter
BSP-MT 1-8	•	•	•	•	
Filtration Performance	General Purpose Pre-filter	High Efficiency Filter	Oil Vapour Reduction Filter	General Purpose Dry Particulate Filter	High Efficiency Dry Particulate Filter
Filtration Grade	Grade ZL	Grade XL	AK	Grade ZL	-
Filtration Type	Coalescing	Coalescing	Adsorption	Dry Particulate	-
Particle Reduction (inc water & oil aerosols)	Down to 1 micron	Down to 0.01 micron	N/A	Down to 1 micron	-
Maximum Remaining Oil Aerosol Content at 21°C	$\leq 0.5 \text{ mg/m}^3$ ($\leq 0.5 \text{ ppm(w)}$)	$\leq 0.01 \text{ mg/m}^3$ ($\leq 0.01 \text{ ppm(w)}$)	N/A	N/A	-
Maximum Remaining Oil Vapour Content at System Temperature	N/A	N/A	$\leq 0.003 \text{ mg/m}^3$ ($\leq 0.003 \text{ ppm(w)}$)	N/A	-
Filtration Efficiency	99.925%	99.9999%	N/A	99.925%	-

Quality Assurance / IP Rating / Pressure Vessel Approvals

Development / Manufacture	ISO 9001 / ISO 14001
Ingress Protection Rating	IP55 Indoor Use Only
EU	Pressure vessel approved for fluid group 2 in accordance with the Pressure Equipment Directive 2014/68/EU
USA	Approval to ASME VIII Div. 1 not required
AUS	Approval to AS1210 not required
GUS	TR (formerly GOST-R)
For use with compressed air only	

BSP-MT 10-95 Breathable Compressed Air Purifier

Dryer Performance

Models	Dewpoint (Standard)		ISO8573-1:2010 Classification (Standard)
	°C	°F	
BSP-MT 10-95	-40	-40	Class 2.2.1

Technical Data

Models	Minimum Operating Pressure		Maximum Operating Pressure		Minimum Operating Temperature		Maximum Operating Temperature		Maximum Ambient Temperature		Electrical Supply (Standard)	Electrical Supply (Option)	Thread Type	Noise Level dB(A)
	bar g	psi g	bar g	psi g	°C	°F	°C	°F	°C	°F				
BSP-MT 10-95	5	73	16	232	5	41	50	122	50	122	230V / 1ph / 50-60Hz	115V / 1ph / 50-60Hz	BSP	<75

Flow Rates

Model	Pipe Size	Flow Rate				Regeneration Air Requirement			
		L/s	m³/min	m³/hr	cfm	L/s	m³/min	m³/hr	cfm
BSP-MT 10	G1	44	2.64	158	93	8.8	0.53	31.6	19
BSP-MT 15	G1	58	3.51	210	124	11.7	0.70	42	25
BSP-MT 20	G1	76	4.58	274	161	15.2	0.92	54.8	32
BSP-MT 25	G1½	103	6.20	371	218	20.6	1.24	74.2	44
BSP-MT 35	G1½	134	8.08	484	285	26.9	1.62	96.8	57
BSP-MT 45	G1½	164	9.84	589	347	32.7	1.97	117.8	69
BSP-MT 60	G2	233	14.01	839	494	46.6	2.80	167.8	99
BSP-MT 75	G2	314	18.85	1129	665	62.7	3.77	225.8	133
BSP-MT 95	G2½	381	22.90	1371	807	76.2	4.58	274.2	161

Stated flows are for operation at 13 bar (g) (189 psi g), 35°C (95°F) with reference to 20°C, 1 bar (a), 0% relative water vapour pressure. For flows at other conditions, apply the correction factors shown below.

Product Selection & Correction Factors

For correct operation, breathing air purifiers must be sized for the maximum (summer) inlet temperature, minimum inlet pressure and maximum flow rate of the installation.

To select a breathing air purifier, first calculate the MPC (Minimum Purification Capacity) using the formula below then select a breathing air purifier from the flow rate table above with a flow rate equal to or above the MPC.

Minimum Purification Capacity = System Flow x Correction Factor

Minimum Inlet Pressure bar g (psi g)	Inlet temperature in °C (°F)					
	25 (77)	30 (86)	35 (95)	40 (104)	45 (113)	50 (122)
5 (73)	2.13	2.17	2.27	2.50	2.78	2.94
6 (87)	1.82	1.85	1.92	2.22	2.50	2.63
7 (102)	1.59	1.61	1.67	2.00	2.27	2.33
8 (116)	1.39	1.43	1.47	1.67	1.85	1.92
9 (131)	1.27	1.28	1.33	1.59	1.67	1.82
10 (145)	1.15	1.16	1.25	1.54	1.59	1.64
11 (160)	1.25	1.27	1.33	1.56	1.64	1.69
12 (174)	1.09	1.10	1.12	1.28	1.37	1.49
13 (189)	0.97	0.98	1.00	1.10	1.22	1.27
14 (203)	0.86	0.87	0.88	1.00	1.06	1.16
15 (218)	0.77	0.78	0.79	0.93	0.97	1.01

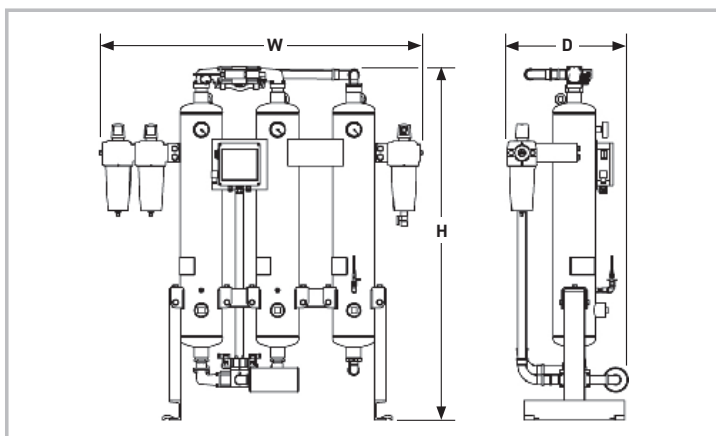

Weights & Dimensions

Model	Pipe Size	Dimensions						Weight	
		Height (H)		Width (W)		Depth (D)			
		mm	ins	mm	ins	mm	ins	kg	lbs
BSP-MT 10	G1	1420	55.9	1300	51.2	490	19.3	164	362
BSP-MT 15	G1	1750	68.9	1300	51.2	490	19.3	197	434
BSP-MT 20	G1	1530	60.2	1100	43.3	490	19.3	196	432
BSP-MT 25	G1½	1760	69.3	1100	43.3	530	20.9	237	522
BSP-MT 35	G1½	1810	71.3	1390	54.7	585	23.0	286	631
BSP-MT 45	G1½	1820	71.7	1455	57.3	605	23.8	341	752
BSP-MT 60	G2	1870	73.6	1515	59.6	635	25.0	435	959
BSP-MT 75	G2	2000	78.7	1665	65.6	635	25.0	562	1239
BSP-MT 95	G2½	2000	78.7	1715	67.5	670	26.4	705	1554

Included Filtration

Model	Dryer Inlet		Dryer Outlet		
	General Purpose Pre-filter	High Efficiency Filter	Oil Vapour Reduction Filter	General Purpose Dry Particulate Filter	High Efficiency Dry Particulate Filter
BSP-MT 10 - BSP-MT 95	•	•	•	•	
Filtration Performance	General Purpose Pre-filter	High Efficiency Filter	Oil Vapour Reduction Filter	General Purpose Dry Particulate Filter	High Efficiency Dry Particulate Filter
Filtration Grade	Grade ZL	Grade XL	AK	Grade ZL	-
Filtration Type	Coalescing	Coalescing	Adsorption	Dry Particulate	-
Particle Reduction (inc water & oil aerosols)	Down to 1 micron	Down to 0.01 micron	N/A	Down to 1 micron	-
Maximum Remaining Oil Aerosol Content at 21°C	≤0.5 mg/m ³ (≤0.5 ppm(w))	≤0.01 mg/m ³ (≤0.01 ppm(w))	N/A	N/A	-
Maximum Remaining Oil Vapour Content at System Temperature	N/A	N/A	≤0.003 mg/m ³ (≤0.003 ppm(w))	N/A	-
Filtration Efficiency	99.925%	99.9999%	N/A	99.925%	-

Quality Assurance / IP Rating / Pressure Vessel Approvals

Development / Manufacture	ISO 9001 / ISO 14001
Ingress Protection Rating	IP55 Indoor Use Only
EU	Pressure vessel approved for fluid group 2 in accordance with the Pressure Equipment Directive 2014/68/EU
USA	Approval to ASME VIII Div. 1 not required
AUS	Approval to AS1210 not required
GUS	TR (formerly GOST-R)
For use with compressed air only	

BAM 10-70 Breathable Compressed Air Purifier

Dryer Performance

Models	Dewpoint (Standard)		ISO8573-1:2010 Classification (Standard)
	°C	°F	
BAM	-40	-40	Class 1.2.1

Technical Data

Models	Minimum Operating Pressure		Maximum Operating Pressure		Minimum Operating Temperature		Maximum Operating Temperature		Maximum Ambient Temperature		Electrical Supply (Standard)	Thread Type	Noise Level dB(A)
	bar g	psi g	bar g	psi g	°C	°F	°C	°F	°C	°F			
BAM10 - BAM70	4	58	13	190	5	41	30	86	55	131	85 - 265V 1ph 50/60Hz	BSPP or NPT	<75

Flow Rates

Model	Pipe Size	Inlet Flow Rate				Regeneration Air Requirement			
		L/s	m³/min	m³/hr	cfm	L/s	m³/min	m³/hr	cfm
BAM10	G2	113	6.81	408	240	22.6	1.36	82	48
BAM20	G2	170	10.22	612	360	34.0	2.04	122	72
BAM30	G2	213	12.78	795	450	42.6	2.60	159	90
BAM40	G2	283	17	1020	600	56.6	3.40	204	120
BAM50	G2½	354	21	1275	750	70.8	4.20	255	150
BAM70	G2½	496	30	1785	1050	99.2	6.00	357	210

Stated flows are for operation at 7 bar (g) (102 psi g) with reference to 20°C, 1 bar (a), 0% relative water vapour pressure. For flows at other conditions, apply the correction factors shown below.

Product Selection & Correction Factors

For correct operation, breathing air purifiers must be sized using for the maximum (summer) inlet temperature, minimum inlet pressure and maximum flow rate of the installation.

To select a breathing air purifier, first calculate the MPC (Minimum Purification Capacity) using the formula below then select a breathing air purifier from the flow rate table above with a flow rate equal to or above the MPC.

$$\text{Minimum Purification Capacity} = \text{System Flow} \times \text{CFMIT} \times \text{CFMIP}$$

CFIT - Correction Factor Maximum Inlet Temperature

Maximum Inlet Temperature	°C	25	30
	°F	77	86
Correction Factor		1.00	1.20

CFMIP - Correction Factor Minimum Inlet Pressure

Minimum Inlet Pressure	bar g	4	5	6	7	8	9	10	11	12	13
	psi g	58	73	87	100	116	131	145	160	174	189
Correction Factor		1.60	1.33	1.14	1.00	0.89	0.80	0.73	0.67	0.62	0.57

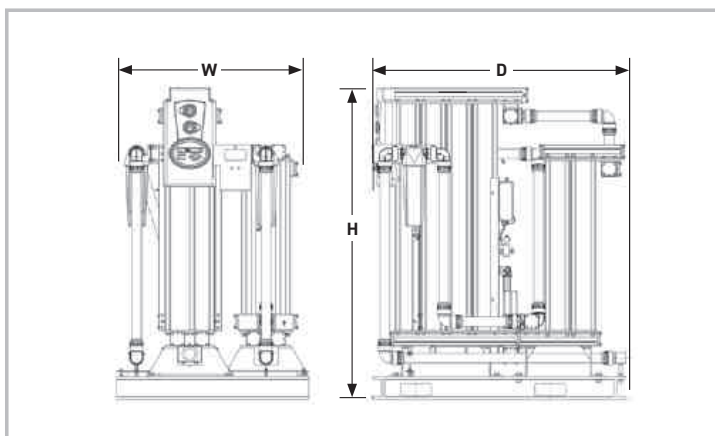

Weights & Dimensions

Model	Pipe Size BSPP	Dimensions						Weight	
		Height (H)		Width (W)		Depth (D)			
		mm	ins	mm	ins	mm	ins	kg	lbs
BAM10	G2	1797	70.7	1260	49.6	1655	65.2	600	1322
BAM20	G2	1797	70.7	1260	49.6	1655	65.2	700	1543
BAM30	G2	2042	80.4	1260	49.6	1655	65.2	800	1763
BAM40	G2½	2042	80.4	1260	49.6	1655	65.2	900	1984
BAM50	G2½	2042	80.4	1260	49.6	1950	76.8	1100	2425
BAM70	G2½	2042	80.4	1260	49.6	1950	76.8	1400	3086

Included Filtration

Models	Pipe Size BSPP or NPT	Dryer Inlet		Dryer Outlet		
		General Purpose Pre-filter	High Efficiency Filter	Oil Vapour Reduction Filter	General Purpose Dry Particulate Filter	High Efficiency Dry Particulate Filter
BAM10 - BAM70	G2	•	•	•	•	•

Filtration Performance	General Purpose Pre-filter	High Efficiency Filter	Oil Vapour Reduction Filter	General Purpose Dry Particulate Filter	High Efficiency Dry Particulate Filter
Filtration Grade	Grade AO	Grade AA	OVR	Grade AO	Grade AA
Filtration Type	Coalescing	Coalescing	Adsorption	Dry Particulate	Coalescing
Particle Reduction (inc water & oil aerosols)	Down to 1 micron	Down to 0.01 micron	N/A	Down to 1 micron	Down to 0.01 micron
Maximum Remaining Oil Aerosol Content at 21°C	≤0.5 mg/m ³ (≤0.5 ppm(w))	≤0.01 mg/m ³ (≤0.01 ppm(w))	N/A	N/A	N/A
Maximum Remaining Oil Vapour Content at System Temperature	N/A	N/A	≤0.003 mg/m ³ (≤0.003 ppm(w))	N/A	N/A
Filtration Efficiency	99.925%	99.9999%	N/A	99.925%	99.9999%

Quality Assurance / IP Rating / Pressure Vessel Approvals

Development / Manufacture	ISO 9001 / ISO 14001
Ingress Protection Rating	IP55 Indoor Use Only
EU	Pressure vessel approved for fluid group 2 in accordance with the Pressure Equipment Directive 2014/68/EU
USA	Approval to ASME VIII Div. 1 not required
AUS	Approval to AS1210 not required
GUS	TR (formerly GOST-R)
For use with compressed air only	

ES2000 Series Oil / Water Separators

Product Selection

Correct selection is critical for the operation of oil/water separators. Increased condensate flow through an oil/water separator reduces settlement time in the main tank, increases oil carryover to the carbon stage & reduces contact time with the carbon. The overall effect of incorrect sizing is poor outlet water quality, reduced carbon filter life and the potential for overflowing.

Capacities shown in this catalogue assume installation in two of the worlds major climatic conditions. Should the oil/water separator be installed in conditions other than those shown, please contact your local Parker outlet or approved distributor/agent for correct sizing.

Oil Types

To simplify the selection, lubricant classifications have been split into three bands depending upon their ability to separate within a static type oil/water separator.

Band A: Turbine Oil, Additive Free Oil

Band B: Mineral

Poly alpha olefins (PAO)

Trimethylolpropane Ester (TMP),

Pentaerythryl Ester (PE)

Band C: Diesters, Triesters,

Polyoxyalkylene glycol (PAG)

Inseparable using static Separation

Techniques: Automatic transmission fluid (ATF)

Drain Types

The condensate should be removed from the compressed air system using a drainage method that does not cause emulsification of the condensate and is appropriate for the unit. Usual methods include :

- **Level Operated Electronic Drain**
- **Float Drain**
- **Timed Solenoid Drain***

Parker recommends the use of the ED3000 Series range of condensate drains. Manual and Thermodynamic Disc trap drains must not be used with the ES2000 Series oil/water separators.

*If the use of timed solenoid drains is unavoidable, steps must be taken to reduce the air loss as this has an emulsifying effect on the condensate.

Refrigeration Dryers

A refrigeration dryer installed in a compressed air system can significantly increase the condensate produced. The oil/water separator must be sized appropriately to treat the extra condensate produced. Flow capacities within this literature are shown both with and without a refrigeration dryer installed.

Important Note:

Additives blended into the lubricants to prevent bacterial growth, rusting, corrosion, and to promote emulsification, such as detergents etc., can have an impact on the separating process. Static oil/water separators are unable to separate stable emulsions or oils that are miscible in water. Additionally, these units will not totally separate lubricants containing: Emulsifying Agents; Glycol additives; or Polyglycol based coolants.

Climate Condition 1 - Outlet quality: <20mg/l oil in water

System Conditions	
Ambient Temperature at Compressor Inlet: 25°C (77°F)	Refrigeration Dryer Dewpoint If Fitted: 3°C
Relative Humidity: 65%	Minimum System Temperature If Refrigeration Dryer Is Not Fitted: 30°C (86°F)
Compressor Discharge Temperature: 35°C (95°F)	System Pressure: 7 bar g (102 psi g) Outlet quality: <20mg/l oil in water

No Refrigeration Dryer Installed in System		Oil Type											
		Band A Turbine, Additive Free				Band B Mineral, PAO, TMP, PE				Band C Diesters, Triesters, PAG			
Compressor Type	Model	L/s	m³/min	m³/hr	cfm	L/s	m³/min	m³/hr	cfm	L/s	m³/min	m³/hr	cfm
Rotary Screw, Vane	ES2100	36.9	2.2	133	78	30.8	1.9	111	66	25.6	1.5	92	54
	ES2150	58.6	3.5	211	124	50.0	3	180	106	40.6	2.4	146	86
	ES2200	90.3	5.4	325	191	76.7	4.6	276	163	62.5	3.7	225	132
	ES2300	126.7	7.6	456	268	106.4	6.4	383	225	87.5	5.3	315	185
	ES2400	253.4	15.2	912	537	212.8	12.8	766	451	175.0	10.5	630	371
	ES2500	501.4	30.1	1805	1062	425.0	25.5	1530	900	346.4	20.8	1247	734
	ES2600	997.6	59.9	3591	2114	849.2	51	3057	1800	689.5	41.4	2482	1461

Refrigeration Dryer Installed in System		Oil Type											
		Band A Turbine, Additive Free				Band B Mineral, PAO, TMP, PE				Band C Diesters, Triesters, PAG			
Compressor Type	Model	L/s	m³/min	m³/hr	cfm	L/s	m³/min	m³/hr	cfm	L/s	m³/min	m³/hr	cfm
Rotary Screw, Vane	ES2100	27.8	1.7	100	59	23.3	1.4	84	49	19.2	1.2	69	41
	ES2150	43.9	2.6	158	93	37.5	2.3	135	80	30.6	1.8	110	65
	ES2200	67.8	4.1	244	144	57.8	3.5	208	122	46.9	2.8	169	99
	ES2300	95.3	5.7	343	202	80.0	4.8	288	169	65.8	3.9	237	139
	ES2400	190.3	11.4	685	403	159.7	9.6	575	339	131.7	7.9	474	279
	ES2500	377.0	22.6	1357	798	319.2	19.2	1149	677	260.6	15.6	938	552
	ES2600	749.8	45	2699	1589	638.4	38.3	2298	1352	518.1	31.1	1865	1098

Climate Condition 2 - Outlet quality: <20mg/l oil in water

System Conditions	
Ambient Temperature at Compressor Inlet: 35°C (95°F)	Refrigeration Dryer Dewpoint If Fitted: 3°C
Relative Humidity: 85%	Minimum System Temperature If Refrigeration Dryer Is Not Fitted: 40°C (104°F)
Compressor Discharge Temperature: 45°C (113°F)	System Pressure: 7 bar g (102 psi g) Outlet quality: <20mg/l oil in water

No Refrigeration Dryer Installed in System		Oil Type											
		Band A Turbine, Additive Free				Band B Mineral, PAO, TMP, PE				Band C Diesters, Triesters, PAG			
Compressor Type	Model	L/s	m³/min	m³/hr	cfm	L/s	m³/min	m³/hr	cfm	L/s	m³/min	m³/hr	cfm
Rotary Screw, Vane	ES2100	13.9	0.8	50	30	11.7	0.7	42	25	9.7	0.6	35	21
	ES2150	22.2	1.3	80	47	18.9	1.1	68	40	15.6	0.9	56	33
	ES2200	34.2	2.1	123	73	29.2	1.7	105	62	23.6	1.4	85	50
	ES2300	48.1	2.9	173	102	40.3	2.4	145	85	33.1	2	119	70
	ES2400	96.1	5.8	346	204	80.6	4.8	290	171	66.4	4	239	141
	ES2500	190.0	11.4	684	403	161.1	9.7	580	341	131.4	7.9	473	278
	ES2600	378.4	22.7	1362	801	322.0	19.3	1159	682	261.4	15.7	941	554

Refrigeration Dryer Installed in System		Oil Type											
		Band A Turbine, Additive Free				Band B Mineral, PAO, TMP, PE				Band C Diesters, Triesters, PAG			
Compressor Type	Model	L/s	m³/min	m³/hr	cfm	L/s	m³/min	m³/hr	cfm	L/s	m³/min	m³/hr	cfm
Rotary Screw, Vane	ES2100	11.4	0.7	41	24	9.4	0.6	34	20	7.8	0.5	28	17
	ES2150	17.8	1.1	64	38	15.3	0.9	55	32	12.5	0.7	45	26
	ES2200	27.5	1.7	99	59	23.6	1.4	85	50	19.2	1.1	69	40
	ES2300	38.9	2.3	140	82	32.5	2	117	69	26.7	1.6	96	57
	ES2400	77.5	4.7	279	164	65.0	3.9	234	138	53.6	3.2	193	114
	ES2500	153.3	9.2	552	325	130.0	7.8	468	275	106.1	6.4	382	225
	ES2600	305.3	18.3	1099	647	260.0	15.6	936	551	210.9	12.7	759	447

For systems using 1 or 2 stage piston/reciprocating compressors multiply compressor flow by 1.4 and select a separator from screw compressor flow rates shown, ensuring due consideration is given to oil type. For sizing at conditions other than those shown, please contact Parker for correct product selection.

Climate Condition 1 - Outlet quality: <10mg/l oil in water

System Conditions
 Ambient Temperature at Compressor Inlet: 25°C (77°F) Refrigeration Dryer Dewpoint If Fitted: 3°C
 Relative Humidity: 65% Minimum System Temperature If Refrigeration Dryer Is Not Fitted: 30°C (86°F)
 Compressor Discharge Temperature: 35°C (95°F) System Pressure: 7 bar g (102 psi g) Outlet quality: <10mg/l oil in water

No Refrigeration Dryer Installed in System		Oil Type											
		Band A				Band B				Band C			
		Turbine, Additive Free				Mineral, PAO, TMP, PE				Diesters, Triesters, PAG			
Compressor Type	Model	L/s	m³/min	m³/hr	cfm	L/s	m³/min	m³/hr	cfm	L/s	m³/min	m³/hr	cfm
Rotary Screw, Vane	ES2100	20.6	1.2	74	43	17.2	1	62	36	14.2	0.9	51	30
	ES2150	32.5	2	117	69	27.8	1.7	100	59	22.5	1.4	81	48
	ES2200	50.3	3	181	106	42.5	2.6	153	90	34.7	2.1	125	73
	ES2300	70.3	4.2	253	149	59.2	3.5	213	125	48.6	2.9	175	103
	ES2400	140.8	8.4	507	298	118.1	7.1	425	250	97.2	5.8	350	206
	ES2500	278.6	16.7	1003	590	236.1	14.2	850	500	192.5	11.6	693	408
	ES2600	554.2	33.3	1995	1174	472.0	28.3	1699	1000	383.1	23	1379	812

Refrigeration Dryer Installed in System		Oil Type											
		Band A				Band B				Band C			
		Turbine, Additive Free				Mineral, PAO, TMP, PE				Diesters, Triesters, PAG			
Compressor Type	Model	L/s	m³/min	m³/hr	cfm	L/s	m³/min	m³/hr	cfm	L/s	m³/min	m³/hr	cfm
Rotary Screw, Vane	ES2100	15.6	0.9	56	33	13.1	0.8	47	27	10.6	0.6	38	23
	ES2150	24.4	1.5	88	52	20.8	1.3	75	44	16.9	1	61	36
	ES2200	37.8	2.3	136	80	31.9	1.9	115	68	26.1	1.6	94	55
	ES2300	52.8	3.2	190	112	44.4	2.7	160	94	36.7	2.2	132	77
	ES2400	105.8	6.3	381	224	88.9	5.3	320	188	73.1	4.4	263	155
	ES2500	209.5	12.6	754	444	177.5	10.6	639	376	144.7	8.7	521	307
	ES2600	416.4	25	1499	883	354.8	21.3	1277	751	287.8	17.3	1036	610

Climate Condition 2 - Outlet quality: <10mg/l oil in water

System Conditions
 Ambient Temperature at Compressor Inlet: 35°C (95°F) Refrigeration Dryer Dewpoint If Fitted: 3°C
 Relative Humidity: 85% Minimum System Temperature If Refrigeration Dryer Is Not Fitted: 40°C (104°F)
 Compressor Discharge Temperature: 45°C (113°F) System Pressure: 7 bar g (102 psi g) Outlet quality: <10mg/l oil in water

No Refrigeration Dryer Installed in System		Oil Type											
		Band A				Band B				Band C			
		Turbine, Additive Free				Mineral, PAO, TMP, PE				Diesters, Triesters, PAG			
Compressor Type	Model	L/s	m³/min	m³/hr	cfm	L/s	m³/min	m³/hr	cfm	L/s	m³/min	m³/hr	cfm
Rotary Screw, Vane	ES2100	7.8	0.5	28	16	6.4	0.4	23	14	5.3	0.3	19	11
	ES2150	12.2	0.7	44	26	10.6	0.6	38	22	8.6	0.5	31	18
	ES2200	18.9	1.1	68	40	16.1	1	58	34	13.1	0.8	47	28
	ES2300	26.7	1.6	96	57	22.5	1.3	81	47	18.3	1.1	66	39
	ES2400	53.3	3.2	192	113	44.7	2.7	161	95	36.9	2.2	133	78
	ES2500	105.6	6.3	380	224	89.5	5.4	322	190	73.1	4.4	263	155
	ES2600	210.0	12.6	756	445	178.9	10.7	644	379	145.3	8.7	523	308

Refrigeration Dryer Installed in System		Oil Type											
		Band A				Band B				Band C			
		Turbine, Additive Free				Mineral, PAO, TMP, PE				Diesters, Triesters, PAG			
Compressor Type	Model	L/s	m³/min	m³/hr	cfm	L/s	m³/min	m³/hr	cfm	L/s	m³/min	m³/hr	cfm
Rotary Screw, Vane	ES2100	6.4	0.4	23	13	5.3	0.3	19	11	4.4	0.3	16	9
	ES2150	10.0	0.6	36	21	8.6	0.5	31	18	6.9	0.4	25	15
	ES2200	15.3	0.9	55	33	13.1	0.8	47	28	10.6	0.6	38	22
	ES2300	21.7	1.3	78	46	18.1	1.1	65	38	15.0	0.9	54	32
	ES2400	43.1	2.6	155	91	36.1	2.2	130	77	29.7	1.8	107	63
	ES2500	85.3	5.1	307	181	72.2	4.3	260	153	58.9	3.5	212	125
	ES2600	169.7	10.2	611	359	144.5	8.7	520	306	117.2	7	422	248

For systems using 1 or 2 stage piston/reciprocating compressors multiply compressor flow by 1.4 and select a separator from screw compressor flow rates shown, ensuring due consideration is given to oil type. For sizing at conditions other than those shown, please contact Parker for correct product selection.

Climate Condition 1 - Outlet quality: <5mg/l oil in water

System Conditions
 Ambient Temperature at Compressor Inlet: 25°C (77°F) Refrigeration Dryer Dewpoint If Fitted: 3°C
 Relative Humidity: 65% Minimum System Temperature If Refrigeration Dryer Is Not Fitted: 30°C (86°F)
 Compressor Discharge Temperature: 35°C (95°F) System Pressure: 7 bar g (102 psi g) Outlet quality: <5mg/l oil in water

No Refrigeration Dryer Installed in System		Oil Type											
		Band A Turbine, Additive Free				Band B Mineral, PAO, TMP, PE				Band C Diesters, Triesters, PAG			
		L/s	m³/min	m³/hr	cfm	L/s	m³/min	m³/hr	cfm	L/s	m³/min	m³/hr	cfm
Rotary Screw, Vane	ES2100	10.3	0.6	37	22	8.6	0.5	31	18	7.2	0.4	26	15
	ES2150	16.4	1	59	34	13.9	0.8	50	29	11.4	0.7	41	24
	ES2200	25.0	1.5	90	53	21.4	1.3	77	45	17.2	1	62	37
	ES2300	35.3	2.1	127	75	29.4	1.8	106	63	24.4	1.5	88	52
	ES2400	70.3	4.2	253	149	59.2	3.5	213	125	48.6	2.9	175	103
	ES2500	139.2	8.4	501	295	118.1	7.1	425	250	96.4	5.8	347	204
	ES2600	277.2	16.6	998	587	235.9	14.2	849	500	191.4	11.5	689	406

Refrigeration Dryer Installed in System		Oil Type											
		Band A Turbine, Additive Free				Band B Mineral, PAO, TMP, PE				Band C Diesters, Triesters, PAG			
		L/s	m³/min	m³/hr	cfm	L/s	m³/min	m³/hr	cfm	L/s	m³/min	m³/hr	cfm
Rotary Screw, Vane	ES2100	7.8	0.5	28	16	6.4	0.4	23	14	5.3	0.3	19	11
	ES2150	12.2	0.7	44	26	10.6	0.6	38	22	8.6	0.5	31	18
	ES2200	18.9	1.1	68	40	16.1	1	58	34	13.1	0.8	47	28
	ES2300	26.4	1.6	95	56	22.2	1.3	80	47	18.3	1.1	66	39
	ES2400	52.8	3.2	190	112	44.4	2.7	160	94	36.7	2.2	132	77
	ES2500	104.7	6.3	377	222	88.6	5.3	319	188	72.2	4.3	260	153
	ES2600	208.4	12.5	750	441	177.2	10.6	638	376	143.9	8.6	518	305

Climate Condition 2 - Outlet quality: <5mg/l oil in water

System Conditions
 Ambient Temperature at Compressor Inlet: 35°C (95°F) Refrigeration Dryer Dewpoint If Fitted: 3°C
 Relative Humidity: 85% Minimum System Temperature If Refrigeration Dryer Is Not Fitted: 40°C (104°F)
 Compressor Discharge Temperature: 45°C (113°F) System Pressure: 7 bar g (102 psi g) Outlet quality: <5mg/l oil in water

No Refrigeration Dryer Installed in System		Oil Type											
		Band A Turbine, Additive Free				Band B Mineral, PAO, TMP, PE				Band C Diesters, Triesters, PAG			
		L/s	m³/min	m³/hr	cfm	L/s	m³/min	m³/hr	cfm	L/s	m³/min	m³/hr	cfm
Rotary Screw, Vane	ES2100	3.9	0.2	14	8	3.3	0.2	12	7	2.8	0.2	10	6
	ES2150	6.1	0.4	22	13	5.3	0.3	19	11	4.2	0.3	15	9
	ES2200	9.4	0.6	34	20	8.1	0.5	29	17	6.7	0.4	24	14
	ES2300	13.3	0.8	48	28	11.1	0.7	40	24	9.2	0.6	33	20
	ES2400	26.7	1.6	96	57	22.5	1.3	81	47	18.3	1.1	66	39
	ES2500	52.8	3.2	190	112	44.7	2.7	161	95	36.4	2.2	131	77
	ES2600	105.0	6.3	378	223	89.5	5.4	322	190	72.5	4.4	261	154

Refrigeration Dryer Installed in System		Oil Type											
		Band A Turbine, Additive Free				Band B Mineral, PAO, TMP, PE				Band C Diesters, Triesters, PAG			
		L/s	m³/min	m³/hr	cfm	L/s	m³/min	m³/hr	cfm	L/s	m³/min	m³/hr	cfm
Rotary Screw, Vane	ES2100	3.1	0.2	11	7	2.5	0.2	9	6	2.2	0.1	8	5
	ES2150	5.0	0.3	18	11	4.2	0.3	15	9	3.3	0.2	12	7
	ES2200	7.8	0.5	28	16	6.4	0.4	23	14	5.3	0.3	19	11
	ES2300	10.8	0.6	39	23	9.2	0.5	33	19	7.5	0.4	27	16
	ES2400	21.7	1.3	78	46	18.1	1.1	65	38	15.0	0.9	54	32
	ES2500	42.5	2.6	153	90	36.1	2.2	130	77	29.4	1.8	106	62
	ES2600	84.7	5.1	305	180	72.2	4.3	260	153	58.6	3.5	211	124

For systems using 1 or 2 stage piston/reciprocating compressors multiply compressor flow by 1.4 and select a separator from screw compressor flow rates shown, ensuring due consideration is given to oil type. For sizing at conditions other than those shown, please contact Parker for correct product selection.

ES2000 Series Oil / Water Separators

Separator Performance

Separator Models	Separator Type	Residual Oil in Water Content (Outlet)	Service Period
ES2100 - ES2600	Static	Each Separator model is sizeable to deliver a residual oil in water level of: <20mg/L <10mg/L <5mg/L	When oil in water levels exceed allowed levels

Technical Data

Model	ES2100	ES2150	ES2200	ES2300	ES2400	ES2500	ES2600
Inlet Connections	1 x ½" 1 x ¼"	1 x ½" 1 x ¼"	1 x ½" 1 x ¼"	1 x ½" 3 x ¼"	1 x ½" 3 x ¼"	1 x ½" 3 x ¼"	1 x ½" 3 x ¼"
Outlet Hose Connections	19mm (¾")	25mm (1")	19mm (¾")	25mm (1")	25mm (1")	25mm (1")	25mm (1")
Settlement Tank Capacity	N/A	60 litres	75 litres	125 litres	185 litres	355 litres	485 litres
	N/A	16 US G	20 US G	33 US G	49 US G	94 US G	128 US G
Max. Pressure	16 bar g (232 psi g)						
Min/ Max Temperature	°C	5 to 35	5 to 35	5 to 35	5 to 35	5 to 35	5 to 35
	°F	41 to 95	41 to 95	41 to 95	41 to 95	41 to 95	41 to 95
Material (Re-cyclable)	Polyethylene						

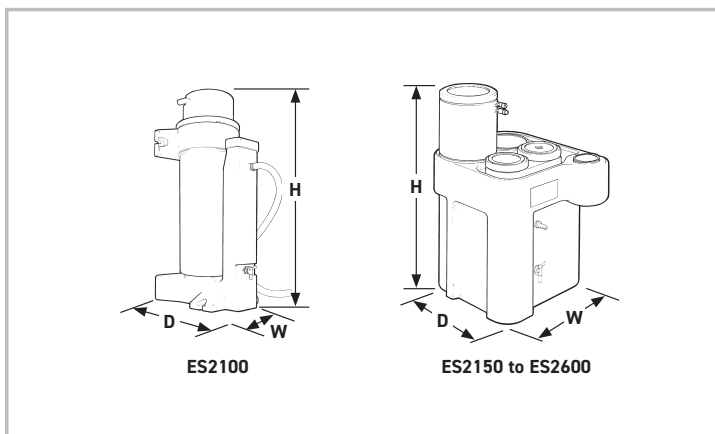

Weights and Dimensions

Model	Height (H)		Width (W)		Depth (D)		Weight			
	mm	ins	mm	ins	mm	ins	Empty		Full	
							kg	lbs	kg	lbs
ES2100	842	33.1	250	9.8	315	12.4	6	13	24.5	154
ES2150	810	31.9	350	13.8	430	16.9	10	22	78.5	173
ES2200	805	31.7	350	13.8	450	17.7	12	26	93.5	206
ES2300	1195	47.0	500	19.7	800	31.5	27	59	159	350
ES2400	1195	47.0	650	26.6	800	31.5	36	79	217	477
ES2500	1535	60.4	700	27.6	985	38.8	70	154	400	880
ES2600	1535	60.4	1000	39.4	1010	39.8	97	214	550	1210

Parker Catalogue Numbers

Model	Catalogue Number
ES2100	ES2100-TI
ES2150	ES2150-TI
ES2200	ES2200-TI
ES2300	ES2300-TI
ES2400	ES2400-TI
ES2500	ES2500-TI
ES2600	ES2600-TI

Maintenance Kits

Model	Quantity Required	Part Number
ES2100-TI	1	ESMK1
ES2150-TI	1	ESMK1
ES2200-TI	1	ESMK1
ES2300-TI	1	ESMK2
ES2400-TI	2	ESMK2
ES2500-TI	1	ESMK3
ES2600-TI	2	ESMK3

Service Kits - Vent Filter

Model	Part Number
ES2100-TI	ESVF1
ES2150-TI	ESVF1
ES2200-TI	ESVF1
ES2300-TI	ESVF2
ES2400-TI	ESVF2
ES2500-TI	ESVF2
ES2600-TI	ESVF2

HDF & ED Level Sensing Condensate Drains

Technical Data

Drain Type	Drain Models	Minimum Operating Pressure		Maximum Operating Pressure		Minimum Operating Temperature		Maximum Operating Temperature	
		bar g	psi g	bar g	psi g	°C	°F	°C	°F
External Float	HDF120 - 220	1	15	16	232	2	35	60	140
Electronic Level Sensing	ED3002 - ED3100	1	15	16	232	2	35	60	140
Electronic Level Sensing	ED4100	16	232	50	725	2	35	50	122

Flow Rates - Zero Air Loss External Float Drains

Model	Pipe Size		Compressed Air Flow Rate				Electrical Supply
	Inlet	Outlet	L/S	m³/min	m³/hr	cfm	
HDF120-A	½"	½"	1500	90	5400	3178	-
HDF180-A	1"	½"	1667	100	6000	3532	-
HDF220-A	1"	½"	4167	251	15000	8829	-
External float drain (with built-in air vent)							
HDF120	½"	½"	1500	90	5400	3178	-
HDF180	1"	½"	1667	100	6000	3532	-
HDF220	1"	½"	4167	251	15000	8829	-
External float drain (without air vent)							
HDF220BE	1"	½"	1806	109	6500	3826	-
External float drains BioEnergy							

Flow Rates - Zero Air Loss Electronic Level Sensing Drains

Model	Pipe Size		Compressed Air Flow Rate (Aftercooler / Air Receiver)				Compressed Air Flow Rate (Refrigeration Dryer)				Compressed Air Flow Rate (Filter)				Electrical Supply
	Inlet	Outlet	L/S	m³/min	m³/hr	cfm	L/S	m³/min	m³/hr	cfm	L/S	m³/min	m³/hr	cfm	
ED3002-G230	1 x G½	G¾	-	-	-	-	-	-	-	-	200	12	720	424	230/1/50-60
ED3004-G230	1 x G½	G¾	67	4	240	141	133	8	480	283	667	40	2400	1413	230/1/50-60
ED3007-G230	2 x G½	G¾	117	7	420	247	233	14	840	494	1167	70	4200	2472	230/1/50-60
ED3030-G230	2 x G½	G¾	500	30	1800	1059	1000	60	3600	2119	5000	301	18000	10595	230/1/50-60
ED3100-G230	2 x G½	G¾	1667	100	6000	3532	3334	200	12000	7063	16668	1002	60000	35316	230/1/50-60
230V/1PH/50-60Hz - 16 bar g (232 psi g)															
ED3007-G24D	2 x G½	G¾	117	7	420	247	233	14	840	494	1167	70	4200	2472	24V DC
ED3030-G24D	2 x G½	G¾	500	30	1800	1059	1000	60	3600	2119	5000	301	18000	10595	24V DC
ED3100-G24D	2 x G½	G¾	1667	100	6000	3532	3334	200	12000	7063	16668	1002	60000	35316	24V DC
24V DC - 16 bar g (232 psi g)															
ED4100/50-G230	G½	G¼	1667	100	6000	3532	3334	200	12000	7063	16668	1002	60000	35316	230/1/50-60
230V/1PH/50-60Hz - 50 bar g (725 psi g)															
ED4100/50-G24D	G½	G¼	1667	100	6000	3532	3334	200	12000	7063	16668	1002	60000	35316	24V DC
24V DC - 50 bar g (725 psi g)															

Stated flows are for operation at max operating pressure shown above, ambient air 25°C (77°F) / 60% RH, compressor discharge temperature 35°C (95°F), refrigeration dryer pressure dewpoint +3°C, with reference to 20°C, 1 bar (a), 0% relative water vapour pressure. . Refrigeration dryer and filter flow rates assume adequate condensate drainage upstream.

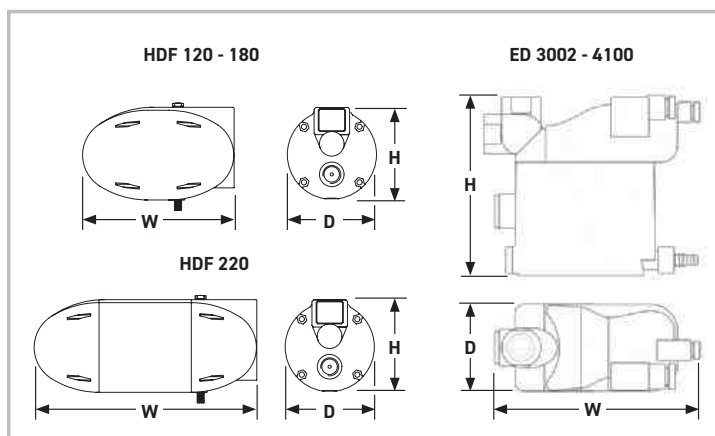

Weight & Dimensions

Model	Height (H)		Width (W)		Depth (D)		Weight	
	mm	ins	mm	ins	mm	ins	kg	lbs
HDF120	111	4.4	156	6.1	108	4.3	0.9	2.0
HDF180	111	4.4	156	6.1	108	4.3	0.9	2.0
HDF220	111	4.4	266	10.5	108	4.3	1.9	4.2
HDF220BE	111	4.4	266	10.5	108	4.3	1.9	4.2
ED3002	146	5.7	110	4.3	67	2.6	0.5	1.1
ED3004	139	5.5	101	4.0	67	2.6	0.6	1.3
ED3007	164	6.5	122	4.8	67	2.6	1	2.2
ED3030	164	6.5	137	5.4	67	2.6	1	2.2
ED3100	164	6.5	197	7.8	67	2.6	2	4.4
ED4100	115	4.5	178	7.0	87	3.4	1.9	4.2

Parker Catalogue Numbers (HDF Drains)

Model	Catalogue Number BSPP / 16 bar g	Catalogue Number BSPP/ 16 bar g + Vent	Catalogue Number NPT / 16 bar g + Vent
HDF120	HDF120	HDF120A	HDF120NPTA
HDF180	HDF180	HDF180A	HDF180NPTA
HDF220	HDF220	HDF220A	HDF220NPTA

Parker Catalogue Numbers (ED Drains)

Model	Catalogue Number 230V, 50-60 Hz / 16 bar g	Catalogue Number 24V DC / 16 bar g
ED3002	ED3002-G230	-
ED3004	ED3004-G230	-
ED3007	ED3007-G230	ED3007-G24D
ED3030	ED3030-G230	ED3030-G24D
ED3100	ED3100-G230	ED3100-G24D

Hypercool Air and Water Cooled Aftercoolers

Technical Data - Hypercool Air Cooled

Model	Flow Rate		Maximum Operating Pressure		Pipe Conn.	Electrical Supply (V/ph/Hz)	Adsorbed Current (A)	Pressure drop at nominal conditions (kPa)	Noise Level at 10 m dB(A)
	m ³ /h	m ³ /min	bar g	psi g					
ADS004	210	3.5	16	232	1½"	230/1/50	0.36	14	44.1
ADT006	360	6	16	232	1½"	400/3/50	0.29	22	54.2
ADT009	540	9	16	232	2"	400/3/50	0.52	13	58.5
ADT028	1680	28	16	232	DN 80	400/3/50	2.70	15	70.3
ADT038	2160	36	16	232	DN 100	400/3/50	2.70	16	70.3
ADT064	3840	64	16	232	DN 150	400/3/50	5.40	26	73.0

Performances refer to models in standard materials, operating with clean cooler, with air at FAD 20°C / 1 bar A, and at the following working conditions: air suction 25°C/60 % RH, 7 bar g working pressure, 120°C compressed air inlet temperature, temperature approach between air outlet and cooling air of ca. 10°C. The performance of models with non standard materials may differ from those quoted above.

Technical Data - Hypercool Water Cooled

Model	Flow Rate		Maximum Operating Pressure		Pipe Conn.	
	m ³ /h	m ³ /min	bar g	psi g	Air	Water

Standard Version

WFN009	540	9	16	232	2"	¾"
WFN027	1620	27	12	174	DN100	1¼"
WFN050	3000	50	12	174	DN125	1¼"
WFN090	5400	90	12	174	DN200	1¼"

Removable Tube-Bundle

WRN007	420	7	16	232	DN 50	½"
WRN016	960	16	16	232	DN 80	¾"
WRN028	1680	28	12	174	DN 100	1"
WRN050	3000	50	12	174	DN 125	1¼"
WRN090	5400	90	12	174	DN 200	1¼"
WRN130	7800	130	10	145	DN 250	1½"
WRN170	10200	170	10	145	DN 300	2"
WRN250	15000	250	10	145	DN 350	DN 65
WRN350	21000	350	10	145	DN 450	DN 80
WRN450	27000	450	10	145	DN 500	DN 100
WRN550	33000	550	10	145	DN 600	DN 100

Performances refer to clean cooler conditions with air at FAD 20°C / 1 bar A, and at the following working conditions: air suction 25°C / 60%RH, 7 bar g working pressure, 120°C compressed air inlet temperature, temperature approach between air outlet and water inlet of ca. 10°C. Maximum air inlet temperature: 200°C (for higher temperatures and other gases contact Parker Sales Companies).

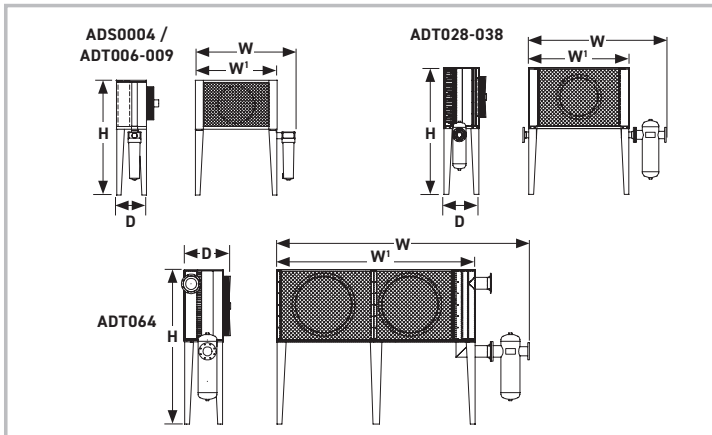

Weights and Dimensions - Hypercool Air Cooled

Model	Height (H)		Width (W)		Width (W')		Depth		Weight	
	mm	ins	mm	ins	mm	ins	mm	ins	kg	lbs
ADS004	1140	44.9	715	28.1	550	21.7	303	11.9	37	81
ADT006	1315	51.8	855	33.7	690	27.2	455	17.9	58	128
ADT009	1315	51.8	1173	46.2	936	36.9	480	18.9	70	154
ADT028	1906	75.0	2054	80.9	1480	58.3	628	24.7	181	398
ADT038	1975	77.8	2263	89.1	1580	62.2	590	23.2	211	464
ADT064	2239	88.1	3650	143.7	2870	113.0	677	26.7	429	944

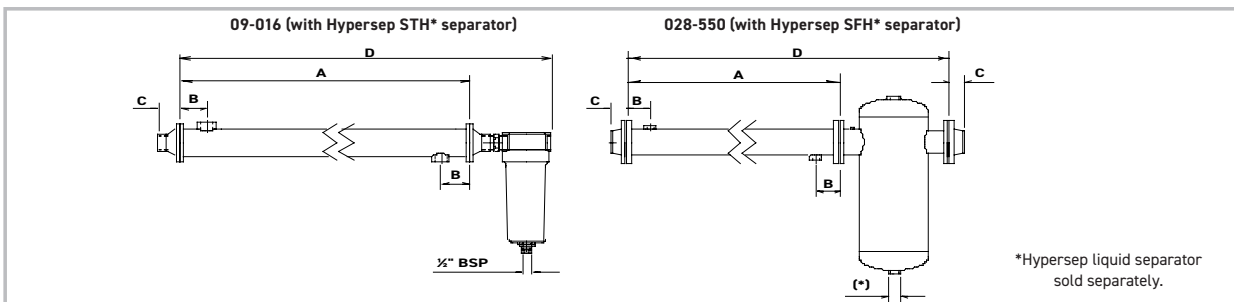

Weights and Dimensions - Hypercool Water Cooled

Model	A		B		C		D		Weight	
	mm	ins	mm	ins	mm	ins	mm	ins	kg	lbs

Standard Version

WFN009	1020	40.2	105	4.1	-	-	1191	46.9	10.5	23
WFN027	900	35.4	115	4.5	54	2.1	1221	48.1	18	40
WFN050	1300	51.2	100	3.9	58	2.3	1963	77.3	71	156
WFN090	1300	51.2	100	3.9	65	2.6	1990	78.3	121	266

Removable Tube-Bundle

WRN007	1050	41.3	72	2.8	77	3.0	1257	49.5	20	44
WRN016	1300	51.2	122	4.8	92	3.6	1563	61.5	37	81
WRN028	1300	51.2	122	4.8	55	2.2	1703	67.0	54	119
WRN050	1300	51.2	123	4.8	58	2.3	1853	73.0	71	156
WRN090	1300	51.2	117	4.6	65	2.6	1873	73.7	161	354
WRN130	1300	51.2	116	4.6	71	2.8	1983	78.1	194	427
WRN170	1300	51.2	116	4.6	71	2.8	2053	80.8	244	537
WRN250	1500	59.1	196.5	7.7	71	2.8	2503	98.5	351	772
WRN350	1500	59.1	148.5	5.8	75	3.0	2703	106.4	400	880
WRN450	1500	59.1	199.5	7.9	78	3.1	3436	135.3	609	1340
WRN550	1515	59.6	200	7.9	83	3.3	3606	142.0	931	2048

Hyperchill Plus Industrial Water Chiller

Technical Data

Model ICEP		002-W	003-W	005-W	007-W	010-W	014-W	020-W	024-W	030-W	040-W	050-W	060-W
Cooling capacity ¹	kW	1.7	3.3	5.2	7.8	10.8	14.6	20.3	23.6	29.7	40.6	49.0	58.3
Compressor abs. power ¹	kW	0.7	1.3	1.4	1.7	2.5	3.2	4.4	5.4	5.7	7.5	10.0	12.3
SEPR ³		3.15	3.73	4.5	4.55	4.86	4.73	4.53	4.51	4.76	5.13	5.12	5.11
Power supply	V/ph/Hz	230/1/50					400/3/50						
Protection index		33					54						
Refrigerant		R407c											

Compressor

Type		hermetic pistons						scroll					
Compressors / circuit		1 / 1											
Max.abs. power ¹ compressor	kW	0.7	1.3	1.5	2.4	3.8	4.4	5.7	6.6	8.3	11.4	14.9	17.3

Axial Fans

Quantity	n.°	1	1	1	1	1	1	2	2	2	2	2	2
Max. abs. power ¹ fan	kW	0.07	0.12	0.12	0.3	0.3	0.4	0.4	0.4	0.45	0.69	0.69	0.69
Air flow	m ³ /h	430	1295	1295	3437	3437	4337	6878	6159	9437	16029	15215	16875

Water Cooled Version

Condenser water flow	m ³ /h	N.A.					1.5	2.1	2.5	2.9	3.9	5.1	5.9
Condenser connections	in	N.A.					¾"	¾"	¾"	1"	1¼"	1¼"	1¼"

Pump P30

Max.abs.power	kW	0.4	0.4	0.4	0.9	0.9	1.0	1.3	1.3	1.3	2.2	2.2	2.2
Water flow (nom./max) ¹	m ³ /h	0.3/1.9	0.6/1.9	0.9/1.9	1.3/4.8	1.8/4.8	2.5/6	3.4/9.6	4.9/9.6	5.1/9.6	6.9/18	8.4/18	10.1/18
Head pressure (nom./max) ¹	m H ₂ O	35/5	33/5	26/5	30/12.8	29/12.8	29/21	29/17.3	28/17.3	26/17.3	29/23.1	27/23.1	25/23.1

Weights & Dimensions

Width	mm	520	755	755	756	756	756	756	756	756	856	856	856
Depth	mm	500	535	535	806	806	806	1206	1206	1206	1956	1956	1956
Height	mm	550	801	801	1405	1405	1405	1405	1405	1405	1680	1680	1680
Connections in/out	in	½"	¾"	¾"	¾"	¾"	¾"	1"	1"	1"	1½"	1½"	1½"
Tank capacity	l	15	15	22.5	65	65	65	100	100	130	250	250	250
Weight (axial)	kg	40	80	85	160	165	175	220	230	250	450	470	510
Weight (water cooled)	kg	n/a	n/a	n/a	n/a	n/a	175	220	230	250	450	470	510

Noise level

Sound pressure (axial) ²	dB(A)	52	52	52	53	53	50	50	50	51	52	52	53
-------------------------------------	-------	----	----	----	----	----	----	----	----	----	----	----	----

- 1) At water in/out temperature 20/15°C, glycol 0%, either 25°C ambient temperature (air-cooled models) or 25°C condenser water inlet temperature with 35°C condensing temperature (water-cooled models).
- 2) Referred to axial fan version in free field conditions at a distance of 10 m from unit, measured on condenser side, 1m from ground.
- 3) Value calculated in accordance with the European regulation (EU) 2016/2281 with regards to Ecodesign requirements for high temperature process chillers.

As the manufacturer of process chillers delivering water at a design temperature of 15°C, Parker Hannifin Manufacturing s.r.l., Gas Separation and Filtration Division EMEA, declares that Parker chillers are exempt from Ecodesign EU regulation 2016/2281.

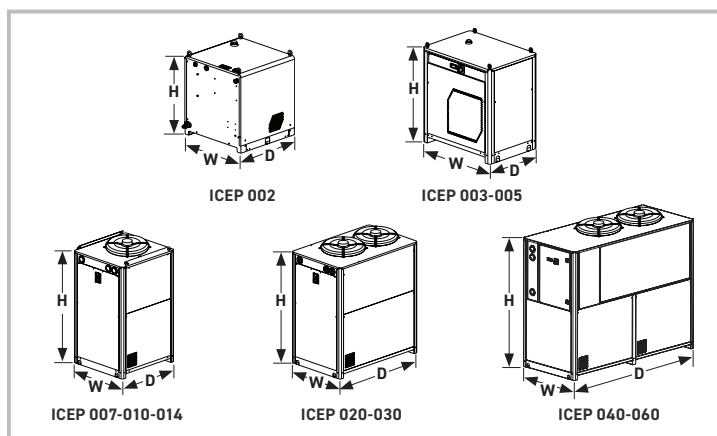

Correction Factors

A)	Ambient Temperature	°C	5	10	15	20	25	30	35	40	45
	Correction Factor (f1)		1.05	1.05	1.05	1.05	1	0.94	0.89	0.84	0.80
B)	Water Outlet Temperature	°C	5	10	15	20	25				
	Correction Factor (f2)		0.76	0.87	1	1.04	1.04				
C)	Glycol (by weight)	%	0	10	20	30	40				
	Correction Factor (f3)		1	0.99	0.98	0.97	0.96				
D)	Condenser Water Inlet Temp.	°C	20	25	30	35	40				
	Correction Factor (f4)		1.05	1	0.95	0.9	0.85				

To obtain the required cooling capacity, multiply the value at nominal conditions by the above correction factors (i.e. cooling capacity = $P \times f1 \times f2 \times f3 \times f4$, where P is the cooling capacity at the water outlet temperature of 15°C). Hyperchill Plus, in its standard configuration, can operate up to ambient temperatures of max. 48°C and min. 5°C and water temperatures of max. 30°C inlet and min. 0°C outlet. The above correction factors are approximative: for a precise selection, always refer to the software selection programme.

Hyperchill Plus Industrial Water Chiller (50Hz)

Standard Part Numbers - Air Cooled with Axial Fans

Hyperchill Plus Air Cooled with axial fans (non ferrous open hydraulic circuit with tank and 3 bar pump)	
ICEP002-W	ICEP002-WASP3T0000001
ICEP003-W	ICEP003-WASP3T0000001
ICEP005-W	ICEP005-WASP3T0000001
Hyperchill Plus Air Cooled with axial fans (non ferrous pressurized closed hydraulic circuit with tank and 3 bar pump)	
ICEP005-W	ICEP005-WASP3T0000000
ICEP007-W	ICEP007-WATP3T0000000
ICEP010-W	ICEP010-WATP3T0000000
ICEP014-W	ICEP014-WATP3T0000000
ICEP020-W	ICEP020-WATP3TOL10000
ICEP024-W	ICEP024-WATP3TOL10000
ICEP030-W	ICEP030-WATP3TOL10000
ICEP040-W	ICEP040-WATP3TOL10000
ICEP050-W	ICEP050-WATP3TOL10000
ICEP060-W	ICEP060-WATP3TOL10000

Options & Standard Features - Air Cooled with Axial Fans

	ICEP002-W	ICEP003-W	ICEP005-W	ICEP007-W	ICEP010-W	ICEP014-W	ICEP020-W	ICEP024-W	ICEP030-W	ICEP040-W	ICEP050-W	ICEP060-W
Differential pressure switch	standard	standard	standard	standard	standard	standard	standard	standard	standard	standard	standard	standard
MODBUS				standard	standard	standard	standard	standard	standard	standard	standard	standard
Eyebolts	standard	standard	standard	standard	standard	standard						
Non ferrous hydraulic circuit with water tank and 3 bar pump	standard	standard	standard	standard	standard	standard	standard	standard	standard	standard	standard	standard
Low ambient -10°C with fan step control							standard	standard	standard	standard	standard	standard
No tank	•	•	•	•	•	•	•	•	•	•	•	•
No tank & no pump	•	•	•	•	•	•	•	•	•	•	•	•
No pump	•	•	•	•	•	•	•	•	•	•	•	•
P50 (5 bar pump)		•	•	•	•	•	•	•	•	•	•	•
P15 (1.5 bar pump)				•	•	•	•	•	•	•	•	•
Dual pump P30 (3 bar pump)										•	•	•
Harting plug	•	•	•	•	•	•	•	•	•	•	•	•
Close control (+/- 0.5°C)		•	•	•	•	•	•	•	•	•	•	•
Low water -10°C				•	•	•	•	•	•	•	•	•
Low ambient -10°C with fan speed control				•	•	•	•	•	•	•	•	•
Low ambient -20°C with fan speed control, crankcase heater and electrical panel heater				•	•	•	•	•	•	•	•	•
Antifreeze heating				•	•	•	•	•	•	•	•	•
BioEnergy & aggressive ambients protection				•	•	•	•	•	•	•	•	•
Tropicalization (53°C)						•	•	•		•	•	•
Differential dynamic set point				•	•	•	•	•	•	•	•	•

Hyperchill Plus Industrial Water Chiller (60Hz UL*)

*ICEP002: UL Compliant / ICEP003-024: UL Listed

Part Number Breakdown / Product Key

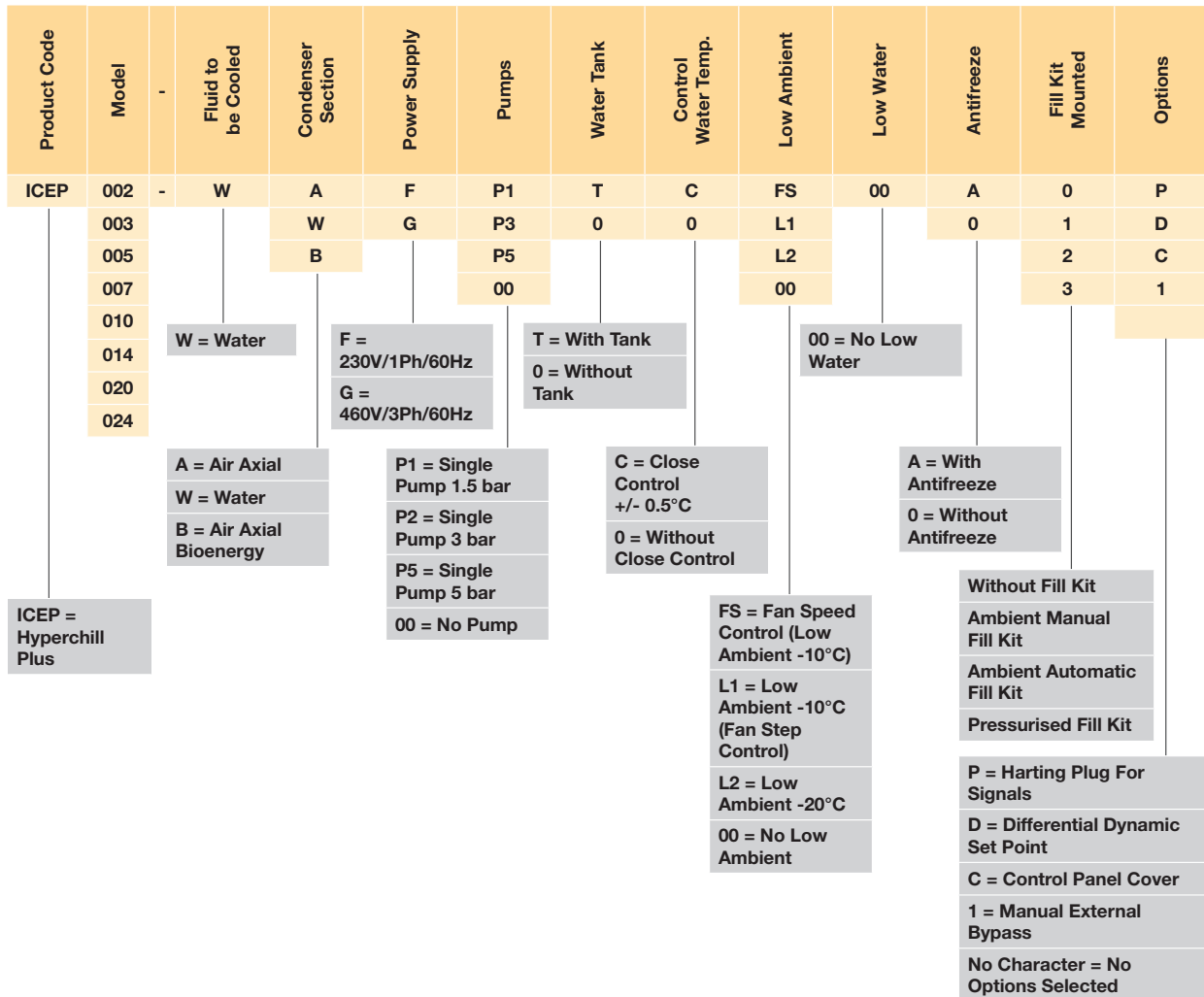

Versions

	ICEP002-W	ICEP003-W	ICEP005-W	ICEP007-W	ICEP010-W	ICEP014-W	ICEP020-W	ICEP024-W
Open Circuit	•	•	•	Available with ambient manual fill kit fitted				
Closed Circuit			•	•	•	•	•	•
Water Cooled						•	•	•

Hyperchill Plus Industrial Water Chiller (60Hz UL*)

Standard Part Numbers - Air Cooled with Axial Fans

Hyperchill Plus Air Cooled with axial fans (non ferrous open hydraulic circuit with tank and 3 bar pump)	
ICEP002-W	ICEP002-WAFP3T0000001
ICEP003-W	ICEP003-WAFP3T0000001
ICEP005-W	ICEP005-WAFP3T0000001
Hyperchill Plus Air Cooled with axial fans (non ferrous pressurized closed hydraulic circuit with tank and 3 bar pump)	
ICEP005-W	ICEP005-WAFP3T0000000
ICEP007-W	ICEP007-WAGP3T0000000
ICEP010-W	ICEP010-WAGP3T0000000
ICEP014-W	ICEP014-WAGP3T0000000
ICEP020-W	ICEP020-WAGP3TOL10000
ICEP024-W	ICEP024-WAGP3TOL10000

Options & Standard Features - Air Cooled with Axial Fans

	ICEP002-W	ICEP003-W	ICEP005-W	ICEP007-W	ICEP010-W	ICEP014-W	ICEP020-W	ICEP024-W
Differential pressure switch	standard	standard	standard	standard	standard	standard	standard	standard
MODBUS				standard	standard	standard	standard	standard
Eyebolts	standard	standard	standard	standard	standard	standard		
Non ferrous hydraulic circuit with water tank and 3 bar pump	standard	standard	standard	standard	standard	standard	standard	standard
Low ambient -10°C with fan step control							standard	standard
No tank	•	•	•	•	•	•	•	•
No tank & no pump	•	•	•	•	•	•	•	•
No pump	•	•	•	•	•	•	•	•
P50 (5 bar pump)		•	•	•	•	•	•	•
P15 (1.5 bar pump)				•	•	•	•	•
Harting plug for signals	•	•	•	•	•	•	•	•
Close control (+/- 0.5°C)		•	•	•	•	•	•	•
Low water -10°C				•	•	•	•	•
Low ambient -10°C with fan speed control				•	•	•	•	•
Low ambient -20°C with fan speed control, cranked heater and electrical panel heater				•	•	•	•	•
BioEnergy & aggressive ambients protection				•	•	•	•	•
Differential dynamic set point				•	•	•	•	•

Hyperchill Plus - Kits and Accessories

Available Kits and Accessories

	ICEP002-W	ICEP003-W	ICEP005-W	ICEP007 - ICEP014	ICEP020 - ICEP030	ICEP040 - ICEP060
Fill kit - ambient manual*** Non-ferrous ambient manual kits, for water filling in any installation.				398H785314	398H785314	398H785314
Fill kit - ambient automatic*** Non-ferrous ambient automatic kits, for water filling in any installation.				398H785316	398H785316	398H785316
Fill kit - pressurised automatic with expansion tank*** Non-ferrous pressurized, automatic kits, with expansion tank. For water filling in any installation.			398H785312	398H785304	398H785304	398H785304
Remote control - base Base version for remote ON/OFF and general alarm monitoring.	398H785009	398H785009	398H785009	398H785010	398H785010	398H785010
Remote control - advanced Advanced version for complete remote unit monitoring.				398H785307	398H785307	398H785307
Wheels For ease of transport.	398H785302	398H785301	398H785301	398H785301		
Control panel cover***				398H785303	398H785303	398H785303
Manual external bypass*** Non-ferrous, externally adjustable allowing the correct flow through the system to be set.		398H785305	398H785305	398H785305	398H785306	398H785317

***From model ICEP007: ambient manual and automatic fill kit, pressurised automatic fill kit, control panel cover, manual external bypass can be supplied already installed or loose.

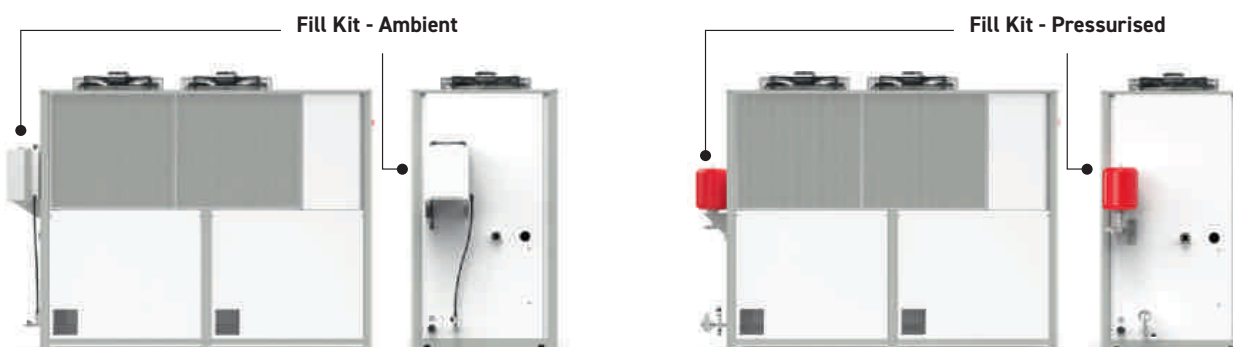

Hyperchill Industrial Process Chiller

Technical Data

Model ICE		076	090	116	150	183	230	310	360
Cooling capacity ¹	kW	76.0	90.2	115.5	149.2	182.3	228	309	360
Compressor abs. power ¹	kW	15.4	20.3	24.9	30.8	40.1	51.4	65	82
SEPR ³		5.39	4.97	5.08	5.35	5.04	4.80	5.51	4.57
Power supply	V/ph/Hz	400/3/50 no neutral							
Protection index		54							
Refrigerant		R407C							

Compressors

Type		Hermetic scroll							
Compressors/circuits		2/2				4/2			
Max abs. power - 1 comp.	kW	11.1	13.7	16.8	11.1	13.7	16.8	23.3	28.7

Axial Fans

Quantity	n°	3			2		3	4	
Max abs. power - 1 fan	kW	0.78	0.78	0.78	2	2	2	2	2
Air flow	m ³ /h	25500	25000	26400	47000	46000	66000	88000	88000

Centrifugal Fans

Quantity	N°	3			3			N.A.	
Max abs. power - 1 fan	kW	1.5	1.5	1.5	3	3	3		
Air flow	m ³ /h	25500	25000	26400	47000	46000	66000		
Head pressure	Pa	100	100	100	180	180	130		

Water Cooled Version

Condenser water flow	m ³ /h	11.1	11.5	16.6	19.2	31.0	33.0	N.A.	
Condensers connections	in	1¼"	1¼"	1¼"	1 ¼"	1¼"	1½"		

Pump P30

Max abs.power	kW	2.5	2.7	2.7	4.5	4.5	4.5	8.4	8.4
Water flow (nom/max) ¹	m ³ /h	13/31	15/27	20/27	25/50	30/50	39/50	53/90	62/90
Head pressure (nom/min) ¹	m H ₂ O	23/13	28/16	25/16	34/20	32/20	26/20	26/19	23/19

Weights & Dimensions

Width	mm	898	898	898	1287	1287	1287	1500	1500
Depth	mm	2200	2200	2200	3000	3000	3260	4200	4200
Height	mm	1984	1984	1984	2298	2298	2298	2240	2240
Connections in/out	in	2"	2"	2"	2½"	2½"	2½"	4"	4"
Tank capacity	l	500	500	500	1000	1000	1000	400	400
Weight (axial)	kg	800	900	1000	1500	1800	2100	2900	3100
Weight (centrif.)	kg	950	1050	1150	1700	2000	2300	N.A.	
Weight (water cooled)	kg	800	900	1000	1500	1800	2100		

Noise level

Sound pressure (axial) ²	dB(A)	58	58	58	62	62	64	65	65
-------------------------------------	-------	----	----	----	----	----	----	----	----

- 1) At water in/out temperature 20/15°C, glycol 0%, either 25°C ambient temperature (air-cooled models) or 25°C condenser water inlet temperature with 35°C condensing temperature (water-cooled models).
- 2) Referred to axial fan version in free field conditions at a distance of 10 m from until, measured on condenser side, 1m from ground.
- 3) Value calculated in accordance with the European regulation (EU) 2016/2281 with regards to Ecodesign requirements for high temperature process chillers.

As the manufacturer of process chillers delivering water at a design temperature of 15°C, Parker Hannifin Manufacturing s.r.l., Gas Separation and Filtration Division EMEA, declares that Parker chillers are exempt from Ecodesign EU regulation 2016/2281.

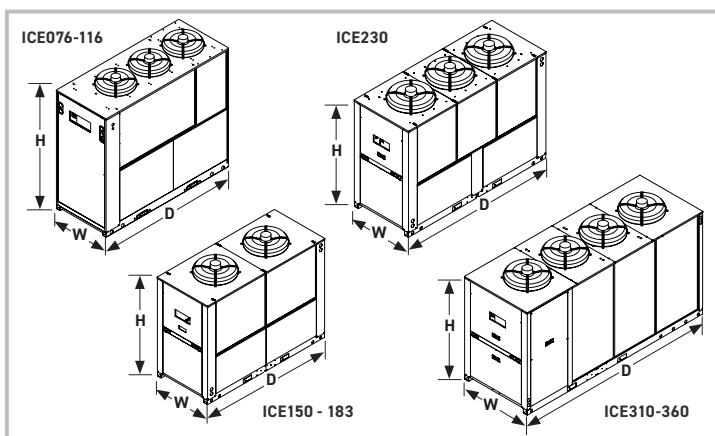

Correction Factors

A)	Ambient Temperature (Air Cooled Models)	°C	5	10	15	20	25	30	35	40	45
	Correction Factor (f1)		1.05	1.05	1.05	1.05	1	0.95	0.89	0.83	0.77
B)	Water Outlet Temperature	°C	5	10	15	20	25				
	Correction Factor (f2)		0.72	0.86	1	1	1				
C)	Glycol	%	0	10	20	30	40	50			
	Correction Factor (f3)		1	0.99	0.98	0.97	0.96	0.94			
D)	Condenser Water Inlet Temp. (Water Cooled Models)	°C	20	25	30	35	40				
	Correction Factor (f4)		1.05	1	0.95	0.9	0.85				

To obtain the required cooling capacity multiply the value at nominal conditions by the above correction factors (i.e. cooling capacity = $P \times f1 \times f2 \times f3 \times f4$, where P is the cooling capacity at conditions (1)). Hyperchill, in its standard configuration, can operate up to ambient temperatures of max 45°C and min. 5°C and water temperatures of max 30°C inlet and min. 0°C outlet. The above correction factors are approximative: for a precise selection always refer to the software selection programme.

Hyperchill Industrial Process Chiller (50Hz)

Part Number Breakdown / Product Key

Product Code	Model	Condenser Section	Power Supply	Pumps	Hydraulic Circuit	Control Water Temp.	Low Ambient	Low Water	Antifreeze
ICE	076	A	400350	1P15	FF	C	LA	LW	A
	090	W		1P30	NF	0	L2	00	0
	116	C		2P30	F0		00		
	150	B		1P50					
	183			0000					
	230								
	310								
	360								

ICE = Hyperchill	A = Air Axial W = Water C = Centrifugal B = BioEnergy & Aggressive Ambients	400350 = 400V/3Ph/50Hz 1P15 = Single Pump 1.5 bar 1P30 = Single Pump 3 bar 2P30 = Dual Pump 3 bar P5 = Single Pump 5 bar 000 = No Pump	FF = With Tank NF = Non Ferrous 0 = Without Tank	C = Close Control +/- 0.5°C 0 = Without Close Control	L1 = Low Ambient -10°C (Fan Step Control) L2 = Low Ambient -20°C 00 = No Low Ambient	LW = Low Water 00 = No Low Water	A = With Antifreeze 0 = Without Antifreeze
------------------	--	---	--	--	--	-------------------------------------	---

Versions

	ICE076	ICE090	ICE116	ICE150	ICE183	ICE230	ICE310	ICE360
Air Cooled with Axial Fans	•	•	•	•	•	•	•	•
Air Cooled with Centrifugal Fan For Air Channeling	•	•	•	•	•	•		
Water Cooled	•	•	•	•	•	•		

Hyperchill Industrial Process Chiller (50Hz)

Standard Part Numbers - Air Cooled with Axial Fans

Hyperchill Air Cooled with axial fans	
ICE076	ICE076A4003501P30FF000000
ICE090	ICE090A4003501P30FF000000
ICE116	ICE116A4003501P30FF000000
ICE150	ICE150A4003501P30FF000000
ICE183	ICE183A4003501P30FF000000
ICE230	ICE230A4003501P30FF000000
ICE310	ICE310A4003501P30F00LA000
ICE360	ICE360A4003501P30F00LA000

Options & Standard Features - Air Cooled with Axial Fans

	ICE076	ICE090	ICE116	ICE150	ICE183	ICE230	ICE310	ICE360
Water tank	standard	standard	standard	standard	standard	standard	•	•
Without tank							standard	standard
P30 (3 bar pump)	standard	standard	standard	standard	standard	standard	•	•
No pump	•	•	•	•	•	•	standard	standard
P50 (5 bar pump)	•	•	•	•	•	•	•	•
P15 (1.5 bar pump)	•	•	•	•	•	•	on request	on request
Dual pump P30 (3 bar pump)	•	•	•	•	•	•	•	•
Close control (+/- 0.5°C)	•	•	•	•	•	•		
Low water -10°C	•	•	•	•	•	•	on request	on request
Low ambient -10°C with fan step control	•	•	•	•	•	•	standard	standard
Low ambient -20°C with fan speed control, cranked heater and electrical panel heater	•	•	•	•	•	•	on request	on request
Antifreeze heating	•	•	•	•	•	•	on request	on request
BioEnergy & aggressive ambients protection	•	•	•	•	•	•	•	•
Non ferrous hydraulic circuit	•	•	•	•	•	•		
MODBUS	on request	on request	on request	on request	on request	on request	on request	on request

Hyperchill Industrial Process Chiller (50Hz)

Standard Part Numbers - Air Cooled with Centrifugal Fans

Hyperchill Air Cooled with centrifugal fans	
ICE076	ICE076C4003501P30FF000000
ICE090	ICE090C4003501P30FF000000
ICE116	ICE116C4003501P30FF000000
ICE150	ICE150C4003501P30FF000000
ICE183	ICE183C4003501P30FF000000
ICE230	ICE230C4003501P30FF000000

Standard Part Numbers - Water Cooled

Hyperchill Water Cooled	
ICE076	ICE076W4003501P30FF000000
ICE090	ICE090W4003501P30FF000000
ICE116	ICE116W4003501P30FF000000
ICE150	ICE150W4003501P30FF000000
ICE183	ICE183W4003501P30FF000000
ICE230	ICE230W4003501P30FF000000

Options & Standard Features - Air Cooled with Centrifugal Fans

	ICE076	ICE090	ICE116	ICE150	ICE183	ICE230
Water tank	standard	standard	standard	standard	standard	standard
P30 (3 bar pump)	standard	standard	standard	standard	standard	standard
No pump	•	•	•	•	•	•
P50 (5 bar pump)	•	•	•	•	•	•
P15 (1.5 bar pump)	•	•	•	•	•	•
Dual pump P30 (3 bar pump)	•	•	•	•	•	•
Close control (+/- 0.5°C)	•	•	•	•	•	•
Low water -10°C	•	•	•	•	•	•
Low ambient -10°C with fan step control	•	•	•	•	•	•
Antifreeze heating	•	•	•	•	•	•
Non ferrous hydraulic circuit	•	•	•	•	•	•

Options & Standard Features - Water Cooled

	ICE076	ICE090	ICE116	ICE150	ICE183	ICE230
Water tank	standard	standard	standard	standard	standard	standard
P30 (3 bar pump)	standard	standard	standard	standard	standard	standard
No pump	•	•	•	•	•	•
P50 (5 bar pump)	•	•	•	•	•	•
P15 (1.5 bar pump)	•	•	•	•	•	•
Dual pump P30 (3 bar pump)	•	•	•	•	•	•
Close control (+/- 0.5°C)	•	•	•	•	•	•
Low water -10°C	•	•	•	•	•	•
Low ambient -10°C with fan step control						
Antifreeze heating	•	•	•	•	•	•
Non ferrous hydraulic circuit	•	•	•	•	•	•

Hyperchill Available Kits and Accessories

	ICE076 - ICE090 PCW080 - PCW330	ICE150 - ICE230 PCW420 - PCW650	ICE310	ICE360
Fill kit - ambient manual	398H785054	398H785053		
Fill kit - ambient automatic	398H785051	398H785052		
Fill kit - pressurised automatic with expansion tank	398H785055	398H785055		
Remote control - base	398H785010	398H785010	398H785010	398H785010
Remote control - advanced	398H785011	398H785011	398H785011	398H785011
Control panel cover	398H785089	398H785089	398H785089	398H785089
Manual external bypass	on request	on request		

Hyperchill Industrial Water Chiller (60Hz UL)

Part Number Breakdown / Product Key

Product Code	Model	Condenser Section	Power Supply	Pumps	Hydraulic Circuit	Control Water Temp.	Low Ambient	Low Water	Options
PCW	080	A	460360	1P30	FF	C	LA	LW	0
	110	B		1P50	NF	0	L2	00	M
	130			0000			00		
	160								
	210								
	260								
	330								
	420								
	510								
	650								

PCW = Hyperchill 60Hz

460360 = 460V/3Ph/60Hz

C = Close Control +/- 0.5°C
Standard Control

LW = Low Water
00 = No Low Water

FF = With Tank
NF = Non Ferrous

LA = Low Ambient -10°C (Fan Step Control)
L2 = Low Ambient -20°C
00 = No Low Ambient

0 = No options
M = Modbus

A = Air Axial
B = BioEnergy & Aggressive Ambients

1P30 = Single Pump 3 bar
P5 = Single Pump 5 bar
000 = No Pump

Standard Part Numbers - Air Cooled with Axial Fans

Hyperchill Air Cooled with axial fans	
PCW080	PCW080A4603601P30FF000000
PCW110	PCW110A4603601P30FF000000
PCW130	PCW130A4603601P30FF000000
PCW160	PCW160A4603601P30FF000000
PCW210	PCW210A4603601P30FF000000
PCW260	PCW260A4603601P30FF000000
PCW330	PCW330A4603601P30FF000000
PCW420	PCW420A4603601P30FF000000
PCW510	PCW510A4603601P30FF000000
PCW650	PCW650A4603601P30FF000000

Options & Standard Features - Air Cooled with Axial Fans

	PCW080	PCW110	PCW130	PCW160	PCW210	PCW260	PCW330	PCW420	PCW510	PCW650
Water tank	standard	standard	standard	standard	standard	standard	standard	standard	standard	standard
P30 (3 bar pump)	standard	standard	standard	standard	standard	standard	standard	standard	standard	standard
No pump	•	•	•	•	•	•	•	•	•	•
P50 (5 bar pump)	•	•	•	•	•	•	•	•	•	•
P15 (1.5 bar pump)	•	•	•	•	•	•	•	•	•	•
Close control (+/- 0.5°C)	•	•	•	•	•	•	•	•	•	•
Low water -10°C	•	•	•	•	•	•	•	•	•	•
Low ambient -10°C with fan step control	•	•	•	•	•	•	•	•	•	•
Low ambient -20°C with fan speed control, crankcase heater and electrical panel heater	•	•	•	•	•	•	•	•	•	•
BioEnergy & aggressive ambients protection	•	•	•	•	•	•	•	•	•	•
Non ferrous hydraulic circuit	•	•	•	•	•	•	•	•	•	•
MODBUS	•	•	•	•	•	•	•	•	•	•

Hyperchill Laser Industrial Process Chiller

Technical Data

Model HLS		076	090	116
Cooling capacity ¹	kW	76.0	90.2	115.5
Compressor abs. power ¹	kW	15.4	20.3	24.9
Cooling capacity ²	kW	67.1	79.9	103.3
Compressor abs. power ²	kW	18.7	24.2	29.9
Power supply	V/ph/Hz	400/3/50 no neutral		
Protection index		54		
Refrigerant		R407C		

Compressors

Type	Hermetic scroll			
Compressors/circuits	2/2			
Max abs. power ¹ comp.	kW	11.1	13.7	16.8

Axial fans

Quantity	n°	3		
Max abs. power ¹ fan	kW	0.78	0.78	0.78
Air flow	m ³ /h	25500	25000	26400

- 1) At water inlet/outlet temperature = 20/15°C, glycol 0 %, ambient temperature 25°C.
- 2) At water inlet/outlet temperature = 25/20°C, glycol 0 %, ambient temperature 35°C.
- 3) Referred to free field conditions at a distance of 10m from unit, measured on condenser side, 1m from ground.

As the manufacturer of process chillers delivering water at a design temperature of 15°C, Parker Hannifin Manufacturing s.r.l., Gas Separation and Filtration Division EMEA, declares that Parker chillers are exempt from Ecodesign EU regulation 2016/2281.

Correction Factors

A)	Ambient Temperature	°C	5	10	15	20	25	30	35	40	45
	Correction Factor (f1)		1.05	1.05	1.05	1.05	1	0.95	0.89	0.83	0.77
B)	Water Outlet Temperature	°C	5	10	15	20	25				
	Correction Factor (f2)		0.72	0.88	1	1	1				
C)	Glycol (by weight)	%	0	10	20	30					
	Correction Factor (f3)		1	0.99	0.98	0.97					

To obtain the required cooling capacity multiply the value at nominal conditions by the above correction factors (i.e. cooling capacity = Pxf1xf2xf3, where P is the cooling capacity at conditions (1)). Hyperchill Laser, in its standard configuration, can operate up to ambient temperatures of max 48 °C for ICEP models, 45°C for HLS models and min 5 °C and water temperatures of max 30 °C inlet and min. 0°C outlet. The above correction factors are approximative: for a precise selection always refer to the software selection program

Pump P30

Max abs.power	kW	2.5	2.7	2.7
Water flow (nom/max) ¹	m ³ /h	13/31	15/27	20/27
Head pressure (nom/min) ¹	m H ₂ O	23/13	28/16	25/16

Pump P50

Max abs.power	kW	4.5	4.5	4.5
Water flow (nom/max) ¹	m ³ /h	13.1/27	15.5/27	19.8/27
Head pressure (nom/min) ¹	m H ₂ O	30/18	28/18	25/18

Weights & Dimensions

Width	mm	898	898	898
Depth	mm	2200	2200	2200
Height	mm	1984	1984	1984
Connections in/out	in	2"	2"	2"
Tank capacity	l	300	300	300
Weight (axial)	kg	750	870	960

Noise level

Sound pressure (axial) ³	dB(A)	58	58	58
-------------------------------------	-------	----	----	----

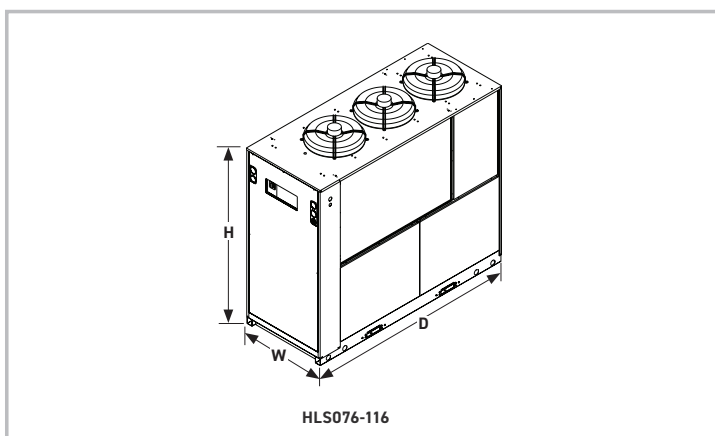

Part Number Breakdown / Product Key

Product Code	Model	Condenser Section	Power Supply	Pumps	Hydraulic Circuit	Control Water Temp.	Low Ambient	Low Water	Antifreeze
HLS	076	A	400350	1P30	SS	C	LA	00	A
	090			1P50					0
	116			0000					

HLS = Hyperchill Laser	A = Air Cooled	400350 = 400V/3Ph/50Hz	1P30 = Single Pump 3 bar P5 = Single Pump 5 bar 000 = No Pump	SS = Stainless Steel With Tank	C = Close Control +/- 0.5°C	00 = No Low Water	LA = Low Ambient -10°C (Fan Step Control)	A = Antifreeze 0 = No Antifreeze
------------------------	----------------	------------------------	---	--------------------------------	-----------------------------	-------------------	---	-------------------------------------

Standard Part Numbers - Air Cooled with Axial Fans

Hyperchill Laser Air Cooled with axial fans, non ferrous hydraulic circuit, close control, low ambient temperature -10°C, manual fill kit.	
HLS076	HLS076A4003501P30SSCLA000
HLS090	HLS090A4003501P30SSCLA000
HLS116	HLS116A4003501P30SSCLA000

Options & Standard Features - Air Cooled with Axial Fans

	HLS076	HLS090	HLS116
Close control (+/- 0.5°C)	standard	standard	standard
P30 (3 bar pump)	standard	standard	standard
Low ambient -10°C	standard	standard	standard
Stainless steel with tank	standard	standard	standard
Antifreeze heating	•	•	•
No pump	•	•	•
P50 (5 bar pump)	•	•	•

Hyperchill Laser Available Kits and Accessories

	HLS076	HLS090	HLS116
Fill kit ambient manual	standard	standard	standard
Remote control base	398H785010	398H785010	398H785010
Closed circuit	398H785011	398H785011	398H785011
Control panel cover	398H785089	398H785089	398H785089
Hydraulic bypass	on request	on request	on request
Automatic check valves	on request	on request	on request

Industrial Nitrogen Gas Applications

There are thousands of applications for industrial gases. Nitrogen is generally used for three main functions:

- It prevents microbial growth or acts as a filler gas in food applications
- It prevents slow oxidization of products such as chemicals and metals during processing or heating
- It prevents rapid oxidization of products that are flammable or explosive

Pharmaceutical

Whether in primary or secondary pharmaceutical product manufacture or as a centralised QA laboratory supply; within research establishments or universities and colleges, Parker can offer a solution to suit the critical demands of this industry sector.

For blanketing of pharmaceutical product ingredients and pressure transfer within reactor vessels, to micronising powders to prevent oxidisation or explosion, Parker nitrogen generators can cut costs, reduce risk and improve productivity.

Centralised laboratory systems remove the need to have high pressure cylinders within the working environment and the possibility of running out of gas during a QA analysis procedure. Parker nitrogen gas generators are typically used for analytical equipment such as LC/MS, GC, reaction blanketing within fume cupboards, solvent evaporation, ICP, ELSD, NMR and circular dichroism.

Food and Beverage

Most food products start to deteriorate from the moment they are harvested or prepared for packaging, being under attack from a multitude of spoilage mechanisms. By flushing, storing and/or packing with nitrogen, oxygen that many of these micro-organisms need in order to survive and multiply, is removed and the spoilage process is significantly reduced.

Prepared salads and vegetables, fresh chilled ready meals, meat, poultry, fish, dairy produce (including cheese), breads, coffee as well as snack foods such as potato chips and nuts can all benefit from 'modified atmosphere packaging' (or MAP as it is often referred to). By using nitrogen gas from a Parker generator, the product shelf life is increased and the appearance and quite often taste, is also improved.

Nitrogen is also used for 'controlled atmosphere storage' of fresh fruits and vegetables, sparging and blanketing food oils as well as bulk powders, cereals and liquid ingredients.

Alcoholic and non-alcoholic drinks and ingredients can suffer similar spoilage mechanisms to food, however one of the most significant threats to product quality is oxidisation which adversely affects product taste. Beer and wine can absorb unwanted dissolved oxygen throughout the production process. Oxygen can also reduce the effectiveness of natural or added vitamin C which maybe used in fruit juices.

Nitrogen gas generators provide an ideal cost effective solution for all of the processes involved in beverage production.

Lasers

Laser Cutting

By far the largest use of nitrogen gas within this industry sector is for laser cutting. Nitrogen gas is used as an 'assist gas' to prevent oxidisation or discolouration and to blow away the molten material from the cut edge.

It is also used in certain types of laser cutting machine as a 'purge gas' to ensure the laser beam guide path from the resonator (where

the beam is generated), to the cutting head, is free of contamination that could otherwise affect the power or alter the shape of the beam.

Laser Sintering

Laser sintering or rapid prototyping uses a laser to form a solid 3D structure within a plastic powder material. Complex shapes and patterns can be constructed and modelled with ease. Nitrogen is used to blanket and prevent oxidisation of the powder material while it melts and solidifies to shape under the heat generated by the laser beam.

Laser Ablation

Nitrogen is used to expel fumes and blanket delicate electronic circuits where a laser beam is used to erode pathways on micro printed circuit boards.

Laser Eye Surgery

Nitrogen is used as a beam purge and pneumatics gas on Eximer laser machines which are used in the corrective treatment of eyesight defects.

Heat Treatment

Nitrogen gas is commonly used to exclude oxygen from heat treatment furnaces and ovens. Parker can supply nitrogen gas generation systems to replace expensive bulk vessel liquid supplies for many heat treatment processes.

Typical applications include:

- Belt furnaces
- Batch furnaces
- Vacuum ovens
- Brazing
- Carburising
- Tempering
- Annealing
- Gas quenching
- Neutral hardening
- Normalising
- Sintering

Fire Prevention and Archive Protection

From the preservation of treasures for the generations after us, to preventing essential data destruction due to fire, Parker nitrogen generators provide a unique solution.

Oxygen depleted air can be pumped into buildings that house treasures and archives or computer stored data to help prevent total loss caused by fire. Museum pieces, paintings, artefacts, furniture and valuable fabrics can all be protected.

In general, only a modest reduction in normal ambient oxygen levels is enough to prevent fire. At 16% oxygen content, archives are protected whilst intermittent human exposure to these levels will have no adverse effects.

What Nitrogen Quality Do I Need?

Traditional gas companies generally provide gas that is of high purity regardless of whether the application or process needs it. This is as a result of the ASU manufacturing process. Typically cylinder and liquid nitrogen has a maximum remaining oxygen content of between 5ppm to 20ppm v/v.

The majority of applications do not need such high purity gas and the benefit of using a higher oxygen content Parker generated gas is that less energy is used to produce it, so the unit gas cost will be more competitive.

For example using nitrogen with a maximum remaining oxygen content of 5% uses 5 times less energy to generate than with a maximum remaining oxygen content of 10ppm.

Providing customers with ultra-high purity nitrogen in all instances is an unnecessary waste of money and energy.

What do we mean by 'purity'?

By purity Parker means the maximum remaining oxygen content in the output nitrogen gas. Parker nitrogen technology when combined with Parker compressed air pre-treatment, guarantees the nitrogen gas to be commercially sterile, oil-free, dry and particulate free. (Within the specifications defined in the product information data contained in this catalogue.)

**The maximum remaining oxygen content required will vary with every application.
Maximum cost and energy savings = maximum oxygen level permissible**



High Purity 10 ppm to 1000ppm (99.999% to 99.9%)

Laser cutting

50ppm to 500ppm

Heat treatment

10ppm to 1000ppm

Electronics soldering

50ppm to 500ppm

Pharmaceutical

10ppm to 5000ppm



Mid Purity 0.1% to 1% (99.9% to 99%)

Food MAP

0.1% to 1%

Food processing

0.1% to 1%

Beer dispense

0.5%

Wine blanketing

0.5%

Oil sparging

0.5%

Brazing

0.5%

Injection molding

0.5% to 1%

Wire annealing

0.5%

Aluminium sparging

0.5%



Low Purity 1% to 5% (99% to 95%)

Fire prevention

5%

Explosion prevention

2% to 5%

Pressure testing

5%

Gas seal blanketing

5%

Pigging

5%

Chemical blanketing

1% to 5%

Autoclaves

5%

Laser sintering

2%

Dry boxes

2%

Nitrogen Gas Generation - Typical PSA Installations

Layout for food and pharmaceutical applications with sterile gas filtration

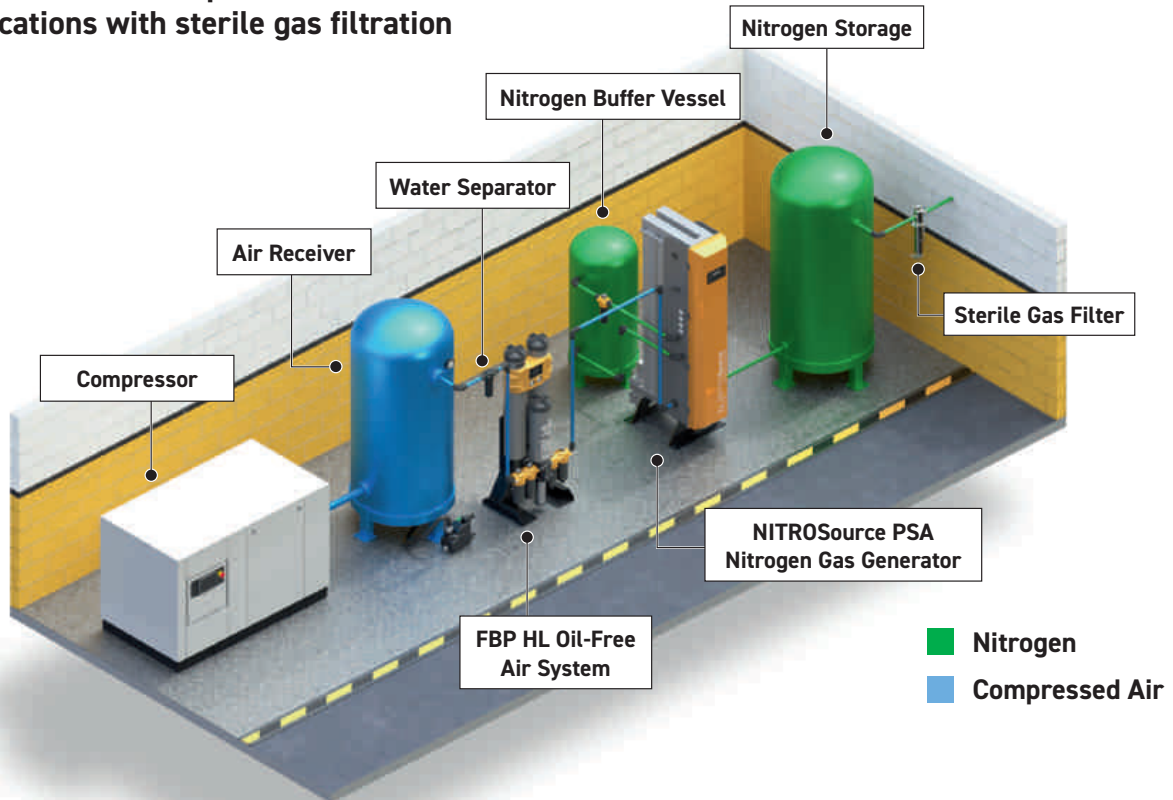

Layout for standard industrial applications

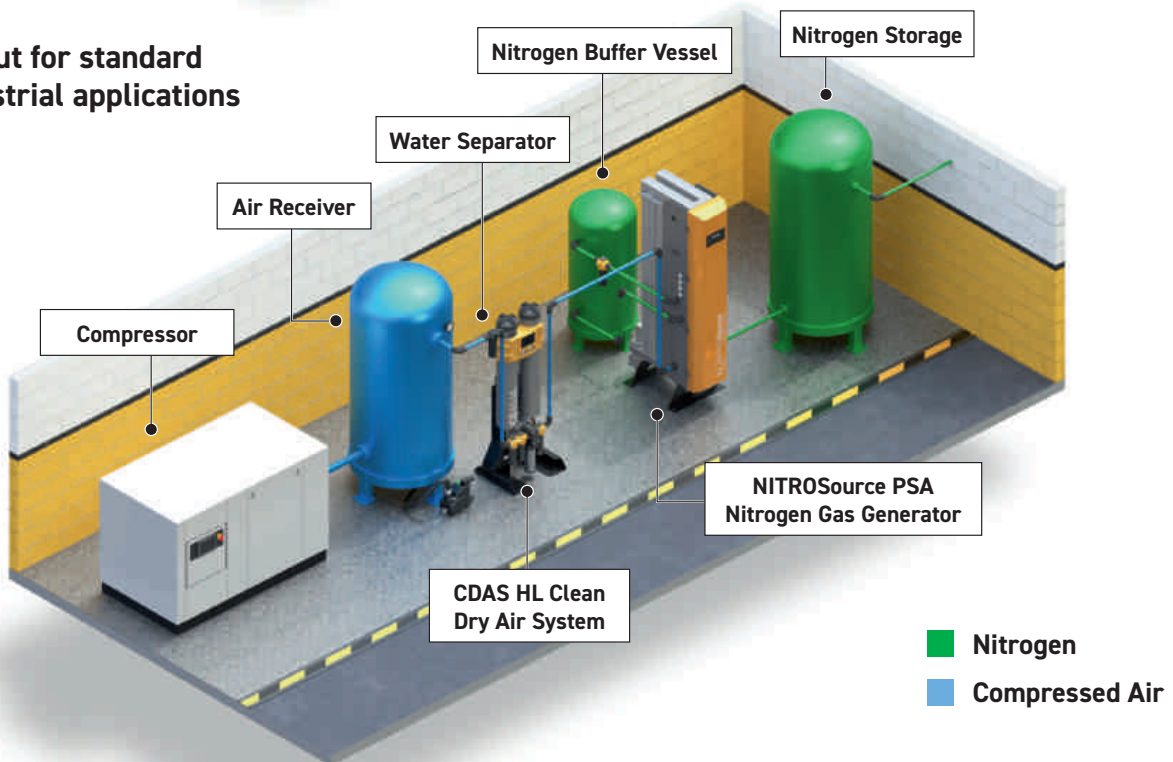

Layout for intermediate pressure 40 barg applications

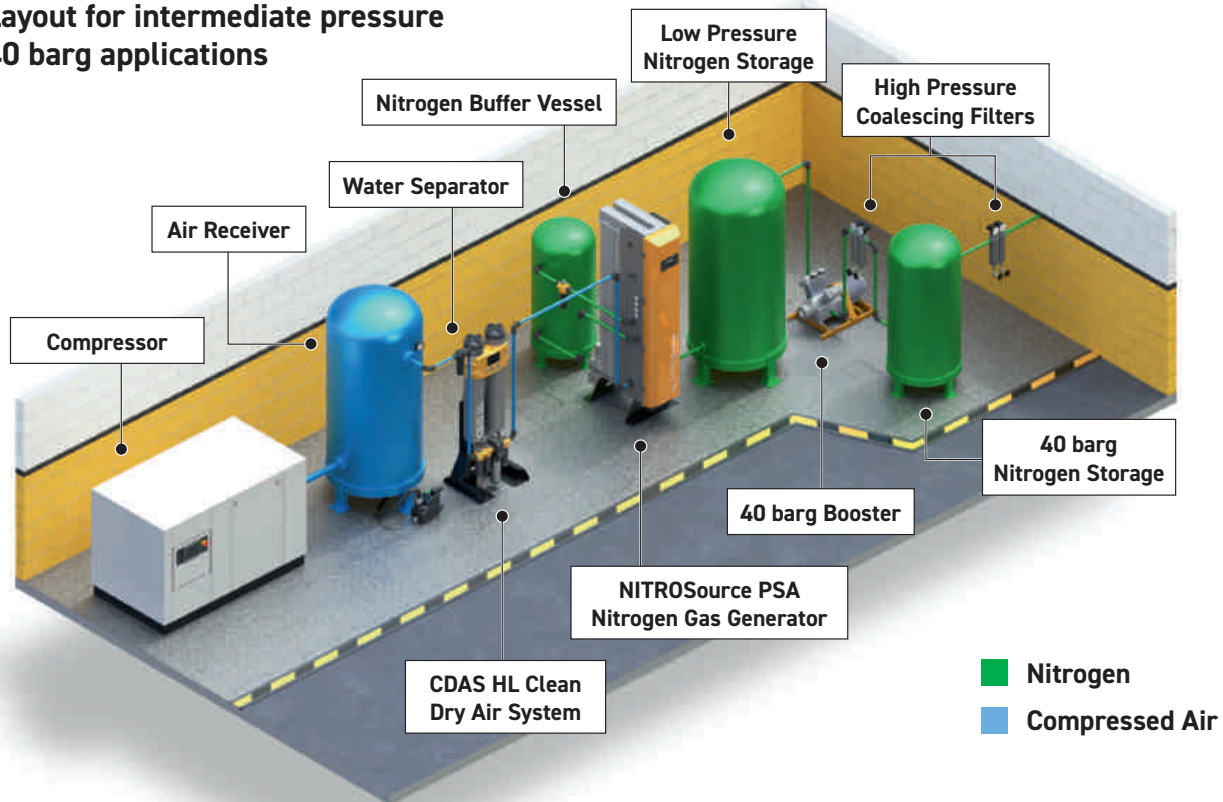

Layout for high pressure 350 barg applications

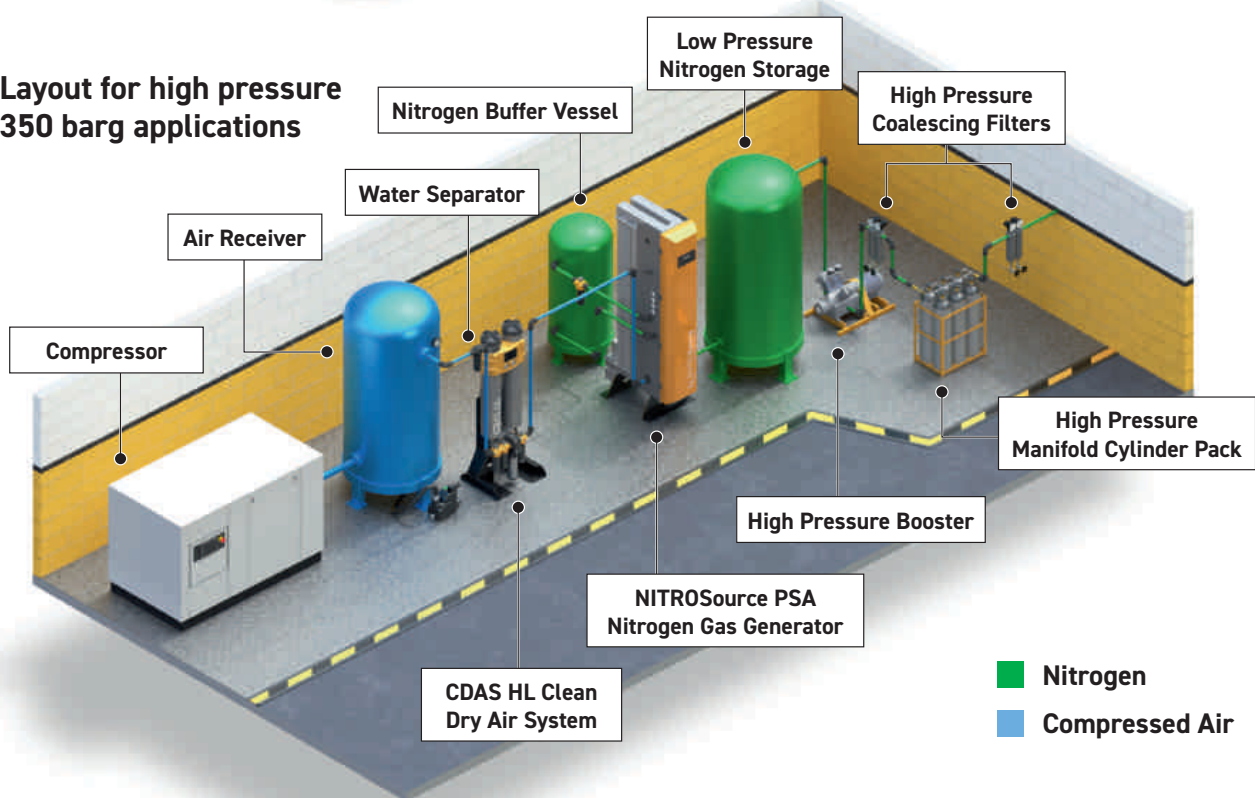

NITROSource PSA Nitrogen Gas Generator

Technical Data

Model	Nitrogen Flow Rates m ³ /hr vs Purity (Oxygen Content)													
	Parts Per Million (ppm)						Percent (%)							
	5	10	50	100	250	500	0.10	0.40	0.50	1	2	3	4	5
N2-20P	3.5	4.5	6.7	8.0	9.7	11.1	12.4	16.7	17.7	21.3	25.3	29.8	30.9	33.7
N2-25P	5.3	6.8	10.1	12.0	14.6	16.7	18.6	25.1	26.6	32.0	38.0	44.7	46.4	50.6
N2-35P	7.0	9.0	13.4	16.0	19.4	22.2	24.8	33.4	35.4	42.6	50.6	59.6	61.8	67.4
N2-45P	8.8	11.3	16.8	20.0	24.3	27.8	31.0	41.8	44.3	53.3	63.3	74.5	77.3	84.3
N2-55P	10.5	13.5	20.1	24.0	29.1	33.3	37.2	50.1	53.1	63.9	75.9	89.4	92.7	101.1
N2-60P	11.6	15.0	22.3	26.6	32.3	36.9	41.2	55.5	58.9	70.8	84.1	99.1	102.7	112.1
N2-65P	13.3	17.1	25.5	30.4	36.9	42.2	47.1	63.5	67.3	80.9	96.1	113.2	117.4	128.1
N2-75P	14.5	18.6	27.7	33.1	40.2	46.0	51.3	69.1	73.3	88.2	104.7	123.4	127.9	139.5
N2-80P	16.1	20.7	30.8	36.8	44.6	51.1	57.0	76.8	81.4	98.0	116.4	137.1	142.1	155.0

Performance data is based on 7 bar g air inlet pressure and 20°C - 25°C ambient temperature. Consult Parker for performance under specific conditions.

m³ reference standard 20°C, 1013 millibar(a), 0% relative water vapour pressure.

Inlet Parameters

Inlet Air Quality	ISO 8573-1: 2010 Class 2.2.2 (2.2.1 with high oil vapour content)
Inlet Air Pressure Range	5 - 13 bar g (72.5 - 217 psi g)

Electrical Parameters

Generator Supply	100 - 240 +/- 10% Vac 50/60Hz
Generator Power	55 W
Fuse	3.15 A (Anti Surge (T), 250v, 5 x 20mm HBC, Breaking Capacity 1500A @ 250v, IEC 60127, UL R/C Fuse)

Environmental Parameters

Ambient Temperature	5 - 50°C (41 - 122°F)
Humidity	50% @ 40°C (80% @ MAX @ 31°C)
IP Rating	IP20 / NEMA 1
Pollution Degree	2
Installation Category	II
Altitude	< 2000 m (6562 ft)
Noise	<80 dB (A)

Port Connections

Air Inlet	G1
N2 Outlet to Buffer	G1
N2 Inlet from Buffer	G½
N2 Outlet	G½

Part Number Breakdown / Product Key

Product Code	-	Model	Technology	O ₂ Purity	Flow @ 5 bar g	Energy Saving Technology (EST)
N2	-	20	P	X	L	N
		25		A	M	Y
		35		B	H	
		45				
		60				
		55				
		65				
		75				
		80				

N2 = NITROSource

P = Pressure Swing Adsorption (PSA)

X = Ultra High Purity (≤10ppm)
 A = High Purity (ppm)
 B = Low Purity (%)

L = Low Flow (0-60 m³/hr)
 M = Medium Flow (60-120 m³/hr)
 H = High Flow (120-300 m³/hr)

N = Does Not Include EST
 Y = Includes EST

Buffer Vessel Sizes

Model	Size (litres)
N2-20P	250
N2-25P	500
N2-35P	500
N2-45P	750
N2-55P	750
N2-60P	750
N2-65P	1000
N2-75P	1000
N2-80P	1000

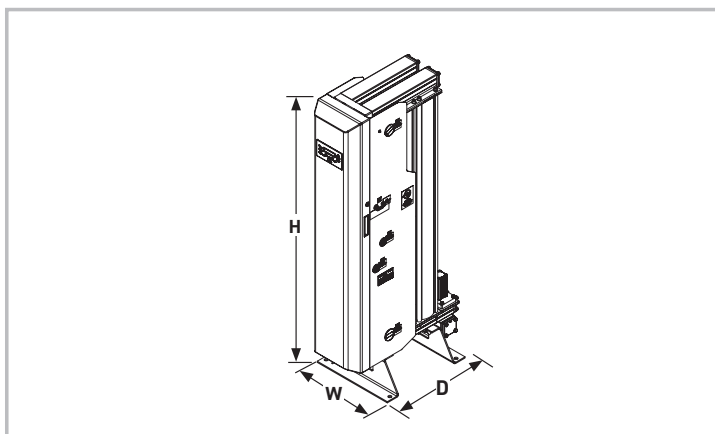

Weights and Dimensions

Model	Unpacked								Packed							
	Height (H)		Width (W)		Depth (D)		Weight		Height		Width		Depth		Weight	
	mm	ins	mm	ins	mm	ins	kg	lbs	mm	ins	mm	ins	mm	ins	kg	lbs
N2-20P	1894	74.6	550	21.7	881	34.7	299	658	729	28.7	2000	78.7	1090	42.9	398.4	876
N2-25P					1050	41.3	384	845					1260	49.6	495.4	1090
N2-35P					1219	48.0	469	1032					1430	56.3	580.4	1277
N2-45P					1388	54.6	553	1217					1600	63.0	686.4	1510
N2-55P					1557	61.3	638	1404	832	32.8			1770	69.7	782.4	1721
N2-60P					1726	68.0	722	1588					1935	76.2	897.4	1974
N2-65P					1895	74.6	807	1775					2100	82.7	997.4	2194
N2-75P					2064	81.3	892	1962	2275	89.6			1093.4	2405		
N2-80P					2233	87.9	976	2147	2445	96.3			1186.4	2610		

Preventative Maintenance Kits

Model	High Purity Generators (ppm)		Low Purity Generators (%)	
	Without EST (Model Nos. N2XXPAXN)	With EST (Model Nos. N2XXPAXY)	Without EST (Model Nos. N2XXPBXN)	With EST (Model Nos. N2XXPBXY)
Kit Part Numbers	M12.NONEST.0001 M24.PPM.0002 M36.STD.0001 M60.STD.0001	M12.EST.0001 M24.PPM.0002 M36.STD.0001 M60.STD.0001	M12.NONEST.0001 M24.PCT.0002 M36.STD.0001 M60.STD.0001	M12.EST.0001 M24.PCT.0002 M36.STD.0001 M60.STD.0001

Kit Contents

Part Number	Description / Service Interval	Contents
M12.NONEST.0001	12 Month Non EST Service Kit (Every 12 Months)	Exhaust Silencer P025AO Dust Filter Element
M12.EST.0001	12 Month EST Service Kit (Every 12 Months)	Exhaust Silencer P025AO Dust Filter Element In-Line Filter
M24.PPM.0002	24 Month PPM Service Kit (Every 24 Months)	PPM Cell c/w Wiring
M24.PCT.0002	24 Month Percentage Service Kit (Every 24 Months)	% Cell c/w Wiring
M36.STD.0001	36 Month Standard Service Kit (Every 36 Months)	8 Bank Solenoid Valve
M60.STD.0001	60 Month Standard Service Kit (Every 24 Months)	40 x 25mm Stroke Cylinders (x6) Over Moulded Valve Discs and Guides (x6) 50 x 100mm Stroke Cylinders (x2) Valve Discs (x2 Sets) Valve Bonnets (x2) Assorted O-Rings Fixing Screws

NITROSource Compact PSA Nitrogen Gas Generator

Please contact Parker for NITROSource Compact performance data or visit parker.com/gsf.

Inlet Parameters

Inlet Air Quality	ISO 8573-1: 2010 Class 2.2.2 (2.2.1 with high oil vapour content)
Inlet Air Pressure Range	6 - 10 bar g (87 - 145 psi g)

Electrical Parameters

Generator Supply	100 - 240 +/- 10% Vac 50/60Hz
Generator Power	55 W
Fuse	3.15 A (Anti Surge (T), 250v, 5 x 20mm HBC, Breaking Capacity 1500A @ 250v, IEC 60127, UL R/C Fuse)

Environmental Parameters

Ambient Temperature	5 - 50°C (41 - 122°F)
Humidity	50% @ 40°C (80% @ MAX @ 31°C)
IP Rating	IP20 / NEMA 1
Pollution Degree	2
Installation Category	II
Altitude	< 2000 m (6562 ft)
Noise	<80 dB (A)

Port Connections

Air Inlet	G1
N2 Outlet to Buffer	G1
N2 Inlet from Buffer	G½
N2 Outlet	G½

Part Number Breakdown / Product Key

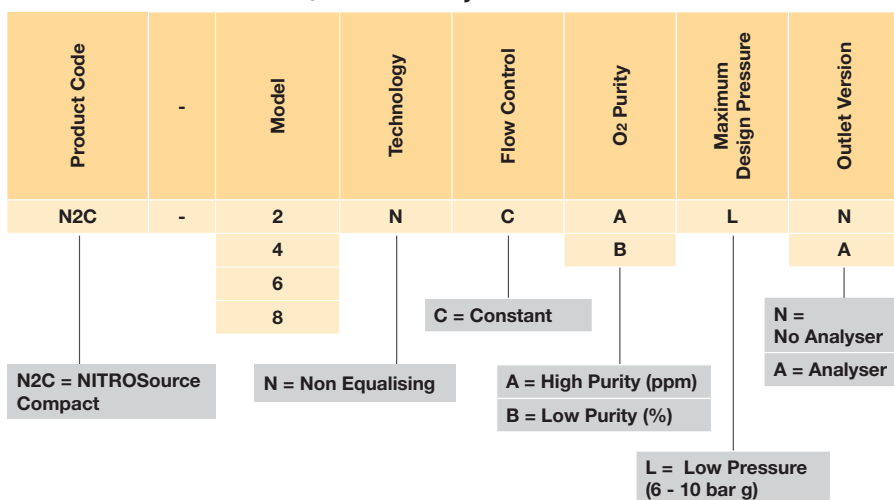

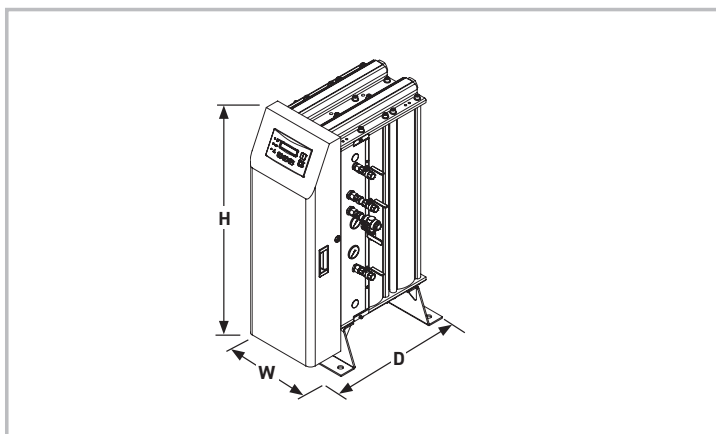

Weights and Dimensions

Model	Unpacked								Packed							
	Height (H)		Width (W)		Depth (D)		Weight		Height		Width		Depth		Weight	
	mm	ins	mm	ins	mm	ins	kg	lbs	mm	ins	mm	ins	mm	ins	kg	lbs
N2C-2	1034	41	450	18	471	19	98	216	1490	59	612	24	950	38	174	383
N2C-4					640	26	145	320							221	487
N2C-6					809	33	196	432							272	597
N2C-8					977	38	249	549							303	668

Preventative Maintenance Kits

Part Number	Description / Service Interval	Contents
606280162	12 Month MIST-X Silencer Kit (Every 12 Months)	MIST-X 150 Silencer
P010AO	12 Month Filter Element Kit (Every 12 Months)	P001AO Dust Filter Element
M24.PPM.0002	24 Month PPM Service Kit (Every 24 Months)	PPM Cell c/w Wiring
M24.PCT.0002	24 Month Percentage Service Kit (Every 24 Months)	% Cell c/w Wiring
606510003	24 Month Valve Overhaul Kit - Generator With Analyser (Every 24 Months)	Air Inlet Valves (x2) Exhaust Valves (x2) Outlet Valves (x2)
606510005	24 Month Valve Overhaul Kit - Generator Without Analyser (Every 24 Months)	Air Inlet Valves (x2) Exhaust Valves (x2) Outlet Valve

SmartFluxx SA604

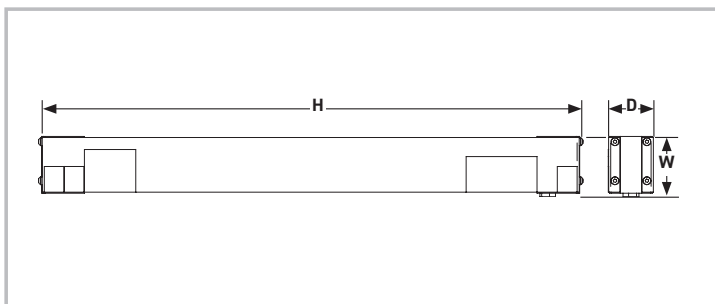

Performance data

Performance data is based on 20°C feed-air temperature and 1013 mbar ambient pressure

Purity %	Typical Nitrogen ¹⁾ flow rate in m ³ /hr ²⁾ (SCFM)					
	99.5	99.0	98.0	97.0	96.0	95.0
4 bar g (58 psi g)	0.20 (0.12)	0.32 (0.19)	0.50 (0.29)	0.73 (0.43)	0.84 (0.49)	1.04 (0.61)
5 bar g (72.5 psi g)	0.28 (0.16)	0.46 (0.27)	0.73 (0.43)	0.92 (0.54)	1.17 (0.69)	1.54 (0.91)
6 bar g (87 psi g)	0.44 (0.21)	0.60 (0.35)	0.92 (0.54)	1.20 (0.71)	1.53 (0.9)	1.75 (1.03)
7 bar g (101.5 psi g)	0.44 (0.26)	0.71 (0.42)	1.16 (0.68)	1.49 (0.88)	1.90 (1.12)	2.10 (1.24)
8 bar g (116 psi g)	0.54 (0.32)	0.85 (0.5)	1.31 (0.77)	1.75 (1.03)	2.17 (1.28)	2.60 (1.53)
9 bar g (130.5 psi g)	0.59 (0.35)	0.97 (0.57)	1.54 (0.91)	2.08 (1.22)	2.50 (1.47)	3.00 (1.77)
10 bar g (145 psi g)	0.67 (0.39)	1.11 (0.65)	1.78 (1.05)	2.29 (1.35)	2.80 (1.65)	3.40 (2)
11 bar g (159.5 psi g)	0.73 (0.43)	1.25 (0.74)	1.95 (1.15)	2.57 (1.51)	3.20 (1.88)	3.90 (2.3)
12 bar g (174 psi g)	0.79 (0.46)	1.39 (0.82)	2.17 (1.28)	2.80 (1.65)	3.40 (2)	4.20 (2.47)
13 bar g (188.5 psi g)	0.89 (0.52)	1.49 (0.88)	2.40 (1.41)	3.10 (1.82)	3.80 (2.24)	4.80 (2.83)

Maximum pressure drop <0.1 bar.

Values between brackets are indicative imperial values

¹⁾The above data represents the typical performance of a single membrane module. Actual performance can vary depending on factors such as feed air pressure and temperature. Please contact your Parker go to person for actual performance information to meet your application's requirements.

²⁾m³/hr refers to conditions at 1013 mbar(a) and 20°C.

For higher purities please contact Parker

Purity %	Typical Feed-air consumption at nitrogen flow rate in m ³ /hr ²⁾ (SCFM)					
	99.5	99.0	98.0	97.0	96.0	95.0
4 bar g (58 psi g)	1.9 (1.1)	1.8 (1.1)	1.9 (1.1)	2.3 (1.4)	2.3 (1.4)	2.5 (1.5)
5 bar g (72.5 psi g)	2.2 (1.3)	2.3 (1.4)	2.6 (1.5)	2.7 (1.6)	3.0 (1.8)	3.6 (2.1)
6 bar g (87 psi g)	2.5 (1.5)	2.8 (1.6)	3.2 (1.9)	3.4 (2)	3.9 (2.3)	4.0 (2.4)
7 bar g (101.5 psi g)	3.0 (1.8)	3.3 (1.9)	3.9 (2.3)	4.2 (2.5)	4.8 (2.8)	4.7 (2.8)
8 bar g (116 psi g)	3.5 (2.1)	3.8 (2.2)	4.4 (2.6)	4.9 (2.9)	5.4 (3.2)	5.8 (3.4)
9 bar g (130.5 psi g)	3.7 (2.2)	4.3 (2.5)	5.1 (3)	5.8 (3.4)	6.3 (3.7)	6.7 (3.9)
10 bar g (145 psi g)	4.1 (2.4)	4.8 (2.8)	5.9 (3.5)	6.3 (3.7)	7.0 (4.1)	7.5 (4.4)
11 bar g (159.5 psi g)	4.4 (2.6)	5.3 (3.1)	6.3 (3.7)	7.1 (4.2)	7.9 (4.6)	8.5 (5)
12 bar g (174 psi g)	4.6 (2.7)	5.9 (3.5)	7.0 (4.1)	7.7 (4.5)	8.4 (4.9)	9.3 (5.5)
13 bar g (188.5 psi g)	5.5 (3.2)	6.4 (3.8)	7.9 (4.6)	8.7 (5.1)	9.5 (5.6)	10.7 (6.3)

Ambient Conditions

Ambient temperature	+2°C to +50°C (+36°F to 122°F)
Ambient pressure	atmospheric
Air quality	clean air without contaminants

Feed-air Conditions

Maximum operating pressure	13.0 bar g (190 psi g)
Min. / Max. operating temperature	+2°C to +50°C (+36°F to 122°F)
Maximum oil vapour content	<0.01 mg/m ³ (<0.01 ppm (w))
Particles	filtered at 0.01 µm cut off
Relative humidity	<100% (non condensing)

Flow Rate Corrections

Nitrogen flow rate at feed-air temperatures other than 20°C	Use bulletin S3.1.240*
Feed-air consumption at feed-air temperatures other than 20°C	Use bulletin S3.1.240*

* Revision number may vary, make sure to use the most recent Revision

Note

Parker membrane systems produce both nitrogen and oxygen enriched air. Nitrogen enriched air can cause suffocation and oxygen enriched air causes increased fire hazards. The oxygen enriched air is available at ambient pressure and pressure build-up of enriched oxygen at the outlet must be prevented, otherwise a serious (reversible) decrease in performance will result. The nitrogen enriched air produced should be treated as pressurised air.

Material

Housing	Steel
Tube	Aluminum
Coating (housing)	ESPC to RAL 7039 (Quartz Grey)
Coating (tube)	none

Services on Request

3D model CAD STEP file

Weight, Dimensions and Connections

Dimensions H x W x D	758 x 80 x 63 mm (29.84" x 3.15" x 2.48")
Weight	3.2 kg (7.05 lb)
Connection feed-air	G ^{3/8} female to ISO 228
Connection nitrogen enriched air	G ^{3/8} female to ISO 228
Connection oxygen enriched air at atmospheric pressure	G ^{3/8} female to ISO 228
Dimensional drawing	Refer to K3.1.344

SmartFluxx SA708

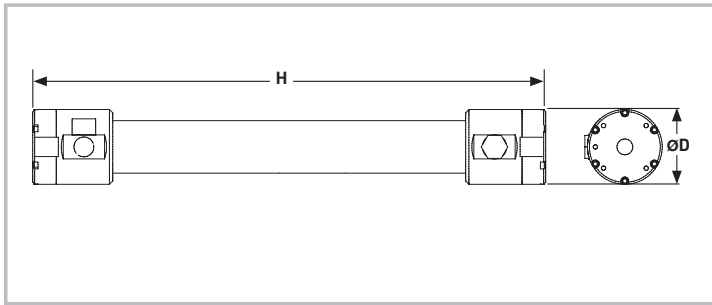

Performance data

Performance data is based on 20°C feed-air temperature and 1013 mbar ambient pressure

Purity %	Typical Nitrogen ¹⁾ flow rate in m ³ /hr ²⁾ (SCFM)							
	99.5	99	98	97	96	95	93	90
4 bar g (58 psi g)	0.90 (0,53)	1.44 (0,85)	2.20 (1,3)	2.91 (1,71)	3.63 (2,14)	4.36 (2,57)		
5 bar g (72.5 psi g)	1.3 (0,77)	2.06 (1,21)	3.09 (1,82)	4.05 (2,38)	5.10 (3)	6.15 (3,62)		
6 bar g (87 psi g)	1.71 (1)	2.67 (1,57)	3.99 (2,35)	5.18 (3,05)	6.56 (3,86)	7.94 (4,67)	11.3 (6,62)	18.2 (10,7)
7 bar g (101.5 psi g)	2.11 (1,24)	3.27 (1,93)	4.90 (2,89)	6.46 (3,8)	8.12 (4,78)	9.78 (5,76)	13.8 (8,1)	22.1 (13)
8 bar g (116 psi g)	2.50 (1,47)	3.87 (2,28)	5.82 (3,42)	7.73 (4,55)	9.67 (5,69)	11.6 (6,84)	16.4 (9,63)	26.6 (15,7)
9 bar g (130.5 psi g)	2.81 (1,66)	4.46 (2,62)	6.77 (3,98)	9.03 (5,32)	11.27 (6,63)	13.5 (7,95)	19.0 (11,2)	30.8 (18,1)
10 bar g (145 psi g)	3.12 (1,84)	4.94 (2,91)	7.64 (4,5)	10.3 (6,08)	12.9 (7,57)	15.4 (9,06)	21.7 (12,8)	35.6 (21)
11 bar g (159.5 psi g)	3.41 (2)	5.46 (3,21)	8.49 (5)	11.5 (6,78)	14.5 (8,51)	17.3 (10,2)		
12 bar g (174 psi g)	3.68 (2,16)	5.96 (3,51)	9.32 (5,49)	12.5 (7,38)	15.9 (9,35)	19.1 (11,2)		
13 bar g (188.5 psi g)	3.93 (2,32)	6.45 (3,8)	10.1 (5,92)	13.6 (7,98)	17.1 (10,1)	20.9 (12,3)		

Maximum pressure drop at Purity <0.2 bar
Values between brackets are indicative of imperial values

¹⁾The above data represents the typical performance of a single membrane module. Actual performance can vary depending on factors such as feed air pressure and temperature. Please contact your Parker go to person for actual performance information to meet your application's requirements.

²⁾m³/hr refers to conditions at 1013mbar(a) and 20°C.
For purities >99.5% please contact Parker

Purity %	Typical Feed-air consumption at nitrogen flow rate in m ³ /hr ²⁾ (SCFM)							
	99.5	99	98	97	96	95	93	90
4 bar g (58 psi g)	7.5 (4,4)	8.6 (5,1)	9.0 (5,3)	9.5 (5,6)	10.4 (6,1)	11.2 (6,6)		
5 bar g (72.5 psi g)	10.1 (6)	11.5 (6,7)	11.7 (6,9)	12.6 (7,4)	14.0 (8,2)	15.2 (8,9)		
6 bar g (87 psi g)	12.3 (7,2)	13.8 (8,1)	14.2 (8,4)	15.3 (9)	17.1 (10,1)	18.8 (11,1)	22.6 (13,3)	29.9 (17,6)
7 bar g (101.5 psi g)	14.7 (8,6)	16.2 (9,6)	17.1 (10)	18.7 (11)	20.8 (12,2)	22.7 (13,4)	27.1 (16)	36.0 (21,2)
8 bar g (116 psi g)	16.5 (9,7)	18.5 (10,9)	19.7 (11,6)	21.9 (12,9)	24.4 (14,4)	26.5 (15,6)	31.8 (18,7)	42.8 (25,2)
9 bar g (130.5 psi g)	18.5 (10,9)	21.1 (12,4)	22.7 (13,4)	25.6 (15,1)	28.3 (16,7)	30.6 (18)	36.8 (21,6)	49.4 (29,1)
10 bar g (145 psi g)	20.4 (12)	23.2 (13,7)	25.5 (15)	29.2 (17,2)	32.1 (18,9)	34.8 (20,5)	42.0 (24,7)	57.2 (33,7)
11 bar g (159.5 psi g)	22.1 (13)	25.5 (15)	28.3 (16,6)	32.4 (19,1)	36.1 (21,2)	39.0 (23)		
12 bar g (174 psi g)	24.1 (14,2)	27.9 (16,4)	31.3 (18,4)	35.5 (20,9)	39.8 (23,4)	43.3 (25,5)		
13 bar g (188.5 psi g)	25.9 (15,3)	30.9 (18,2)	34.3 (20,2)	38.8 (22,8)	43.2 (25,5)	47.8 (28,1)		

Ambient Conditions

Ambient temperature	+2°C to +50°C (+36°F to 122°F)
Ambient pressure	atmospheric
Air quality	clean air without contaminants

Feed-air Conditions

Maximum operating pressure	13.0 bar g (190 psi g)
Min. / Max. operating temperature	+2°C / +50°C (+36°F to 122°F)
Maximum oil vapour content	<0.01 mg/m ³ (<0.01 ppm (w))
Particles	filtered at 0.01 µm cut off
Relative humidity	<100% (non condensing)

Flow Rate Corrections

Nitrogen flow rate at feed-air temperatures other than 20°C	Use bulletin S3.1.240*
Feed-air consumption at feed-air temperatures other than 20°C	Use bulletin S3.1.240*

* Revision number may vary, make sure to use the most recent Revision

Note

Parker membrane systems produce both nitrogen and oxygen enriched air. Nitrogen enriched air can cause suffocation and oxygen enriched air causes increased fire hazards. The oxygen enriched air is available at ambient pressure and pressure build-up of enriched oxygen at the outlet must be prevented, otherwise a serious (reversible) decrease in performance will result. The nitrogen enriched air produced should be treated as pressurised air.

Mechanical Design Housing

Design pressure	15 bar g ⁴⁾ (217 psi g ⁴⁾)
Design temperature	65°C ⁴⁾ (149°F ⁴⁾)

⁴⁾ Membrane ambient and operating conditions are lower

Material

Housing	Aluminum
Coating	ESPC to RAL 7039 (Quartz Grey) Dry Film Thickness: 60 micron

Services on Request

3D model CAD STEP file

Weight, Dimensions and Connections

Dimensions H x Ø D	782 x 114 mm (30.79" x 4.49")
Weight	5.5 kg (12.1 lb)
Connection feed-air	G ³ / ₄ female to ISO 228
Connection nitrogen enriched air	G ³ / ₄ female to ISO 228
Connection oxygen enriched air at atmospheric pressure enriched air	G1 female to ISO 228
Dimensional drawing	Refer to K3.1.383

SmartFluxx SA1508

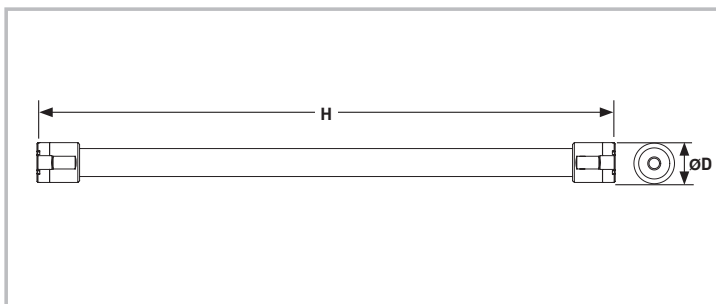

Performance data

Performance data is based on 20°C feed-air temperature and 1013 mbar ambient pressure

Purity %	Typical Nitrogen ¹⁾ flow rate in m ³ /hr ²⁾ (SCFM)					
	99.5	99.0	98.0	97.0	96.0	95.0
4 bar g (58 psi g)	2.8 (1.6)	4.0 (2.4)	5.7 (3.4)	7.1 (4.2)	9.5 (5.6)	10.9 (6.4)
5 bar g (72.5 psi g)	3.7 (2.2)	5.3 (3.1)	7.9 (4.6)	10.2 (6)	12.8 (7.5)	15.2 (8.9)
6 bar g (87 psi g)	4.7 (2.8)	7.0 (4.1)	10.2 (6)	13.0 (7.7)	15.7 (9.2)	20.5 (12.1)
7 bar g (101.5 psi g)	6.1 (3.6)	8.5 (5)	12.3 (7.2)	16.5 (9.7)	19.5 (11.5)	24.3 (14.3)
8 bar g (116 psi g)	6.9 (4.1)	9.7 (5.7)	14.3 (8.4)	20.2 (11.9)	23.3 (13.7)	28.1 (16.5)
9 bar g (130.5 psi g)	7.8 (4.6)	11.1 (6.5)	17.0 (10)	22.2 (13.1)	27.0 (15.9)	32.2 (19)
10 bar g (145 psi g)	8.6 (5.1)	12.6 (7.4)	18.5 (10.9)	24.2 (14.2)	30.2 (17.8)	37.4 (22)
11 bar g (159.5 psi g)	9.6 (5.7)	14.2 (8.4)	20.7 (12.2)	27.3 (16.1)	33.0 (19.4)	41.0 (24.1)
12 bar g (174 psi g)	10.5 (6.2)	15.2 (8.9)	22.9 (13.5)	29.5 (17.4)	36.6 (21.5)	45.6 (26.8)
13 bar g (188.5 psi g)	11.3 (6.7)	16.3 (9.6)	24.9 (14.7)	32.0 (18.8)	39.5 (23.2)	48.8 (28.7)

Maximum pressure drop at Purity <0.2 bar
Values between brackets are indicative of imperial values

¹⁾ The above data represents the typical performance of a single membrane module. Actual performance can vary depending on factors such as feed air pressure and temperature. Please contact your Parker go to person for actual performance information to meet your application's requirements.

²⁾ m³/hr refers to conditions at 1013 mbar(a) and 20°C
For purities >99.5% please contact Parker

Purity %	Typical Feed-air consumption at nitrogen flow rate in m ³ /hr ²⁾ (SCFM)					
	99.5	99.0	98.0	97.0	96.0	95.0
4 bar g (58 psi g)	21 (12)	21 (12)	22 (13)	22 (13)	26 (15)	27 (16)
5 bar g (72.5 psi g)	24 (14)	26 (15)	29 (17)	31 (18)	34 (20)	36 (21)
6 bar g (87 psi g)	29 (17)	33 (19)	36 (21)	38 (22)	41 (24)	48 (28)
7 bar g (101.5 psi g)	36 (21)	38 (22)	41 (24)	48 (28)	50 (29)	56 (33)
8 bar g (116 psi g)	38 (22)	42 (25)	47 (28)	56 (33)	58 (34)	63 (37)
9 bar g (130.5 psi g)	44 (26)	48 (28)	55 (32)	62 (36)	67 (39)	72 (42)
10 bar g (145 psi g)	50 (29)	56 (33)	61 (36)	68 (40)	75 (44)	84 (49)
11 bar g (159.5 psi g)	51 (30)	60 (35)	66 (39)	74 (44)	80 (47)	91 (54)
12 bar g (174 psi g)	57 (34)	65 (38)	76 (45)	83 (49)	92 (54)	103 (61)
13 bar g (188.5 psi g)	66 (39)	72 (42)	85 (50)	92 (54)	101 (59)	113 (67)

Mechanical Design Housing

Design pressure	15 bar g ⁴⁾ (217 psi g ⁴⁾
Design temperature	65°C ⁴⁾ (149°F ⁴⁾

⁴⁾ Membrane ambient and operating conditions are lower

Material

Housing	Aluminum
Coating	ESPC to RAL 7039 (Quartz Grey) Dry Film Thickness: 60 micron

Services on Request

Material certificates EN10204-3.1 on housing material (for Stainless Steel only)
3D model CAD STEP file

Weight, Dimensions and Connections

Dimensions H x Ø D	1655 x 114 mm (65.12" x 4.49")
Weight	6.8 kg (15 lb)
Connection feed-air	G¾ female to ISO 228
Connection nitrogen enriched air	G¾ female to ISO 228
Connection oxygen enriched air at atmospheric pressure	G1 female to ISO 228
Dimensional drawing	Refer to K3.1.330

Ambient Conditions

Ambient temperature	+2°C to +50°C (+36°F to 122°F)
Ambient pressure	atmospheric
Air quality	clean air without contaminants

Feed-air Conditions

Maximum operating pressure	13.0 bar g (190 psi g)
Min. / Max. operating temperature	+2°C / +50°C (+36°F to 122°F)
Maximum oil vapour content	<0.01 mg/m ³ (<0.01 ppm (w))
Particles	filtered at 0.01 µm cut off
Relative humidity	<100% (non condensing)

Flow Rate Corrections

Nitrogen flow rate at feed-air temperatures other than 20°C	Use bulletin S3.1.240*
Feed-air consumption at feed-air temperatures other than 20°C	Use bulletin S3.1.240*

* Revision number may vary, make sure to use the most recent revision

Note

Parker membrane systems produce both nitrogen and oxygen enriched air. Nitrogen enriched air can cause suffocation and oxygen enriched air causes increased fire hazards. The oxygen enriched air is available at ambient pressure and pressure build-up of enriched oxygen at the outlet must be prevented, otherwise a serious (reversible) decrease in performance will result. The nitrogen enriched air produced should be treated as pressurised air.

SmartFluxx SA1508SS

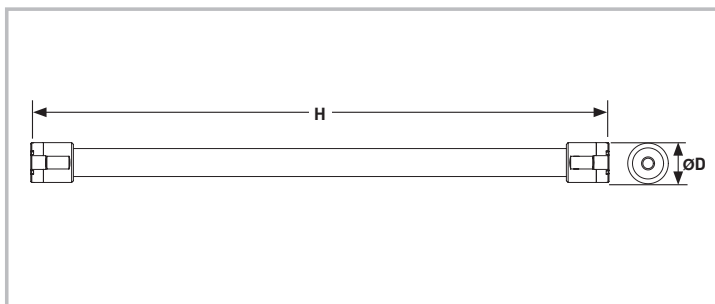

Performance data

Performance data is based on 20°C feed-air temperature and 1013 mbar ambient pressure

Purity %	Typical Nitrogen ¹⁾ flow rate in m ³ /hr ²⁾ (SCFM)					
	99.5	99.0	98.0	97.0	96.0	95.0
4 bar g (58 psi g)	2.8 (1.6)	4.0 (2.4)	5.7 (3.4)	7.1 (4.2)	9.5 (5.6)	10.9 (6.4)
5 bar g (72.5 psi g)	3.7 (2.2)	5.3 (3.1)	7.9 (4.6)	10.2 (6)	12.8 (7.5)	15.2 (8.9)
6 bar g (87 psi g)	4.7 (2.8)	7.0 (4.1)	10.2 (6)	13.0 (7.7)	15.7 (9.2)	20.5 (12.1)
7 bar g (101.5 psi g)	6.1 (3.6)	8.5 (5)	12.3 (7.2)	16.5 (9.7)	19.5 (11.5)	24.3 (14.3)
8 bar g (116 psi g)	6.9 (4.1)	9.7 (5.7)	14.3 (8.4)	20.2 (11.9)	23.3 (13.7)	28.1 (16.5)
9 bar g (130.5 psi g)	7.8 (4.6)	11.1 (6.5)	17.0 (10)	22.2 (13.1)	27.0 (15.9)	32.2 (19)
10 bar g (145 psi g)	8.6 (5.1)	12.6 (7.4)	18.5 (10.9)	24.2 (14.2)	30.2 (17.8)	37.4 (22)
11 bar g (159.5 psi g)	9.6 (5.7)	14.2 (8.4)	20.7 (12.2)	27.3 (16.1)	33.0 (19.4)	41.0 (24.1)
12 bar g (174 psi g)	10.5 (6.2)	15.2 (8.9)	22.9 (13.5)	29.5 (17.4)	36.6 (21.5)	45.6 (26.8)
13 bar g (188.5 psi g)	11.3 (6.7)	16.3 (9.6)	24.9 (14.7)	32.0 (18.8)	39.5 (23.2)	48.8 (28.7)

Maximum pressure drop at Purity <0.2 bar

Values between brackets are indicative of imperial values

¹⁾The above data represents the typical performance of a single membrane module. Actual performance can vary depending on factors such as feed air pressure and temperature. Please contact your Parker go to person for actual performance information to meet your application's requirements.

²⁾m³/hr refers to conditions at 1013 mbar(a) and 20°C

For purities >99.5% please contact Parker

Purity %	Typical Feed-air consumption at nitrogen flow rate in m ³ /hr ²⁾ (SCFM)					
	99.5	99.0	98.0	97.0	96.0	95.0
4 bar g (58 psi g)	21 (12)	21 (12)	22 (13)	22 (13)	26 (15)	27 (16)
5 bar g (72.5 psi g)	24 (14)	26 (15)	29 (17)	31 (18)	34 (20)	36 (21)
6 bar g (87 psi g)	29 (17)	33 (19)	36 (21)	38 (22)	41 (24)	48 (28)
7 bar g (101.5 psi g)	36 (21)	38 (22)	41 (24)	48 (28)	50 (29)	56 (33)
8 bar g (116 psi g)	38 (22)	42 (25)	47 (28)	56 (33)	58 (34)	63 (37)
9 bar g (130.5 psi g)	44 (26)	48 (28)	55 (32)	62 (36)	67 (39)	72 (42)
10 bar g (145 psi g)	50 (29)	56 (33)	61 (36)	68 (40)	75 (45)	84 (49)
11 bar g (159.5 psi g)	51 (30)	60 (35)	66 (39)	74 (44)	80 (47)	91 (54)
12 bar g (174 psi g)	57 (34)	65 (38)	76 (45)	83 (49)	92 (54)	103 (61)
13 bar g (188.5 psi g)	66 (39)	72 (42)	85 (50)	92 (54)	101 (59)	113 (67)

Mechanical Design Housing

Design pressure	15 bar g ⁴⁾ (217 psi g ⁴⁾)
Design temperature	65°C ⁴⁾ (149°F ⁴⁾)

⁴⁾ Membrane operating limits are lower

Material

Housing	Stainless Steel
Coating	None

Services on Request

Material certificates EN10204-3.1 on housing material (for Stainless Steel only)
3D model CAD STEP file

Weight, Dimensions and Connections

Dimensions H x Ø D	1654 x 114 mm (65.12" x 4.49")
Weight	18 kg (40 lb)
Connection feed-air	G¾ female to ISO 228
Connection nitrogen enriched air	G¾ female to ISO 228
Connection oxygen enriched air at atmospheric pressure	G1 female to ISO 228
Dimensional drawing	Refer to K3.1.330

Ambient Conditions

Ambient temperature	+2°C to +50°C (+36°F to 122°F)
Ambient pressure	atmospheric
Air quality	clean air without contaminants

Feed-air Conditions

Maximum operating pressure	13.0 bar g (190 psi g)
Min. / Max. operating temperature	+2°C to +50°C (+36°F to 122°F)
Maximum oil vapour content	<0.01 mg/m ³ (<0.01 ppm (w))
Particles	filtered at 0.01 µm cut off
Relative humidity	<100% (non condensing)

Flow Rate Corrections

Nitrogen flow rate at feed-air temperatures other than 20°C	Use bulletin S3.1.240*
Feed-air consumption at feed-air temperatures other than 20°C	Use bulletin S3.1.240*

* Revision number may vary, make sure to use the most recent revision

Note

Parker membrane systems produce both nitrogen and oxygen enriched air. Nitrogen enriched air can cause suffocation and oxygen enriched air causes increased fire hazards. The oxygen enriched air is available at ambient pressure and pressure build-up of enriched oxygen at the outlet must be prevented, otherwise a serious (reversible) decrease in performance will result. The nitrogen enriched air produced should be treated as pressurised air.

SmartFluxx SA15020

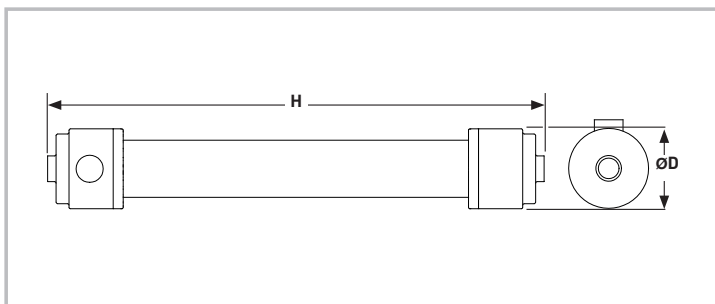

Performance data

Performance data is based on 20°C feed-air temperature and 1013 mbar ambient pressure

Purity %	Typical Nitrogen ¹⁾ flow rate in m ³ /hr ²⁾ (SCFM)					
	99.5	99.0	98.0	97.0	96.0	95.0
4 bar g (58 psi g)	17 (10)	25 (15)	36 (21)	47 (28)	57 (34)	70 (41)
5 bar g (72.5 psi g)	23 (14)	33 (19)	49 (29)	66 (39)	82 (48)	93 (55)
6 bar g (87 psi g)	29 (17)	43 (25)	63 (37)	83 (49)	102 (60)	120 (71)
7 bar g (101.5 psi g)	37 (22)	53 (31)	78 (46)	100 (59)	125 (74)	154 (91)
8 bar g (116 psi g)	44 (26)	62 (36)	90 (53)	117 (69)	144 (85)	178 (105)
9 bar g (130.5 psi g)	49 (29)	72 (42)	103 (61)	133 (78)	165 (97)	216 (127)

Purity %	Typical Feed-air consumption at nitrogen flow rate in m ³ /hr ²⁾ (SCFM)					
	99.5	99.0	98.0	97.0	96.0	95.0
4 bar g (58 psi g)	127 (75)	126 (74)	135 (79)	145 (85)	155 (91)	169 (99)
5 bar g (72.5 psi g)	144 (85)	155 (91)	171 (101)	194 (114)	216 (127)	218 (128)
6 bar g (87 psi g)	170 (100)	191 (112)	214 (126)	239 (141)	261 (154)	276 (162)
7 bar g (101.5 psi g)	202 (119)	223 (131)	258 (152)	281 (165)	315 (185)	348 (205)
8 bar g (116 psi g)	232 (137)	255 (150)	293 (172)	323 (190)	361 (212)	399 (235)
9 bar g (130.5 psi g)	264 (155)	298 (175)	335 (197)	369 (217)	413 (243)	485 (285)

Maximum pressure drop at Purity: ≤0.2 bar

Values between brackets are indicative imperial values*

¹⁾ The above data represents the typical performance of a single membrane module. Actual performance can vary depending on factors such as feed air pressure and temperature.

Please contact your Parker go to person for actual performance information to meet your application's requirements.

²⁾ m³/hr refers to conditions at 1013 mbar(a) and 20°C

For higher purities please contact Parker

Ambient Conditions

Ambient temperature	+2°C to +50°C (+36°F to 122°F)
Ambient pressure	atmospheric
Air quality	clean air without contaminants

Operating Conditions Feed-air

Maximum operating pressure	9.0 bar g (130.5 psi g)
Min. / Max. operating temperature	+2°C to +50°C (+36°F to 122°F)
Maximum oil vapour content	<0.01 mg/m ³ (<0.01 ppm (w))
Particles	filtered at 0.01 µm cut off
Relative humidity	<100% (non condensing)

Flow Rate Corrections

Nitrogen flow rate at feed-air temperatures other than 20°C	Use bulletin S3.1.240 ³⁾
Feed-air consumption at feed-air temperatures other than 20°C	Use bulletin S3.1.240 ³⁾

³⁾ Revision number may vary, make sure to use the most recent revision

Note

Parker membrane systems produce both nitrogen and oxygen enriched air. Nitrogen enriched air can cause suffocation and oxygen enriched air causes increased fire hazards. The oxygen enriched air is available at ambient pressure and pressure build-up of enriched oxygen at the outlet must be prevented, otherwise a serious (reversible) decrease in performance will result. The nitrogen enriched air produced should be treated as pressurised air.

Mechanical Design Housing

Design pressure	14 bar g ⁴⁾ (203 psi g ⁴⁾)
Design temperature	65°C ⁴⁾ (149°F ⁴⁾)

⁴⁾ Membrane operating limits are lower

Material

Housing	Aluminum
Coating	ESPC to RAL 7039 (Quartz Grey) Dry Film Thickness: 60 micron

Services Available on Request

3D model CAD STEP file

Weight, Dimensions and Connections

Dimensions H x Ø D	1740 x 280 mm (68.50" x 11.02")
Weight	46 kg (102 lb)
Connection feed-air	G2½ female to ISO 228
Connection nitrogen enriched air	G2½ female to ISO 228
Connection oxygen enriched air at atmospheric pressure	100mm (3.94") OD
Dimensional drawing	Refer to K3.1.339

HiFluxx ST304

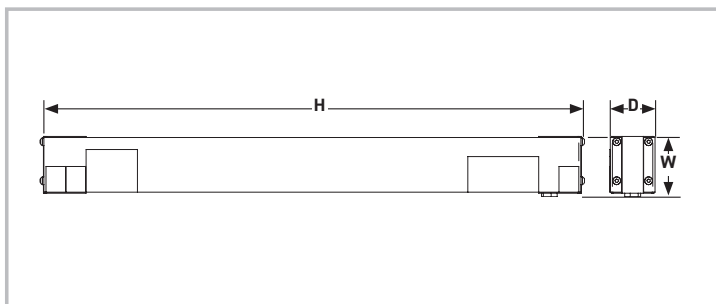

Performance data

Performance data is based on 20°C feed-air temperature and 1013 mbar ambient pressure

Purity % ¹	Minimum nitrogen flow rate in m ³ /hr ²				
	99	98	97	96	95
4 bar g	0.15	0.27	0.39	0.50	0.62
5 bar g	0.19	0.34	0.48	0.62	0.78
6 bar g	0.25	0.45	0.62	0.80	0.98
7 bar g	0.29	0.52	0.73	0.93	1.14
8 bar g	0.33	0.60	0.83	1.06	1.31
9 bar g	0.39	0.70	0.95	1.23	1.52
10 bar g	0.41	0.75	1.04	1.33	1.64
11 bar g	0.43	0.82	1.15	1.48	1.83
12 bar g	0.45	0.89	1.25	1.63	2.02

Purity %	Feed-air consumption at minimum nitrogen flow rate in m ³ /hr ²				
	99	98	97	96	95
4 bar g	1.16	1.29	1.43	1.54	1.69
5 bar g	1.44	1.61	1.78	1.92	2.11
6 bar g	1.73	1.98	2.18	2.39	2.65
7 bar g	2.02	2.31	2.55	2.79	3.09
8 bar g	2.31	2.64	2.91	3.19	3.53
9 bar g	2.70	3.06	3.33	3.69	4.10
10 bar g	2.89	3.30	3.64	3.99	4.42
11 bar g	3.45	3.85	4.24	4.58	4.94
12 bar g	3.60	4.17	4.63	5.04	5.46

Maximum pressure drop <0.3 bar.

Maximum nitrogen flow rate = minimum flow rate + 30%

¹ Parker membranes separate oxygen from pressurised air. The composition of the product is determined by measuring the residual oxygen content. The nitrogen content is calculated by subtracting the residual oxygen content from 100 %. Air is composed of nitrogen (78.1%), oxygen (20.9%), Argon (0.9%), CO₂ (0.03%), and some trace inert gases. Therefore it should be born in mind that the value that is normally called the nitrogen content actually is the inert gas content.

² m³/hr refers to conditions at 1013mbar(a) and 20 °C

Ambient Conditions

Ambient temperature	+2°C to +50°C
Ambient pressure	atmospheric
Air quality	clean air without contaminants

Feed-air Conditions

Maximum operating pressure	13.0 bar g
Min. / Max. operating temperature	+2°C / +50°C
Maximum oil vapour content	<0.01 mg/m ³
Particles	filtered at 0.01 µm cut off
Relative humidity	<100% (non condensing)

Flow Rate Corrections

Nitrogen flow rate at feed temperatures other than 20°C	Use bulletin S3.1.059*
Feed-air consumption at feed-air temperatures other than 20°C	Use bulletin S3.1.059*

* version number may vary, make sure to use the most recent version

Material

Housing	Aluminum
---------	----------

Services on Request

3D model CAD STEP file

Weight, Dimensions and Connections

Dimensions H x W x D	386 x 80 x 63 mm
Weight	2.3 kg
Connection inlet / outlet	G ^{3/8} female
Vent	G ^{3/8} female
Dimensional drawing	Refer to K3.1.348

Note

Parker membrane systems produce both nitrogen and oxygen enriched air. Nitrogen enriched air can cause suffocation and oxygen enriched air causes increased fire hazards. The oxygen enriched air is available at ambient pressure and pressure build-up of enriched oxygen at the outlet must be prevented, otherwise a serious (reversible) decrease in performance will result. The nitrogen enriched air produced should be treated as pressurised air.

HiFluxx DT304

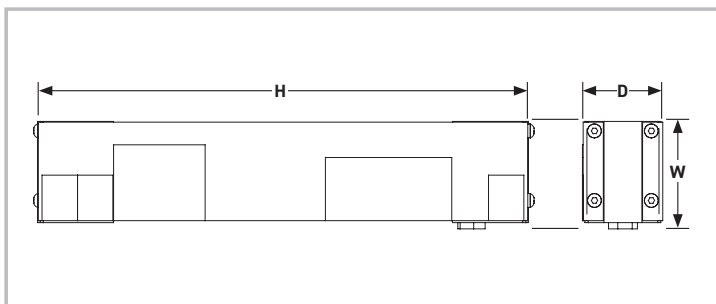

Performance data

Performance data is based on 20°C feed-air temperature and 1013 mbar ambient pressure

Purity % ¹	Minimum nitrogen flow rate in m ³ /hr ²					
	99.5	99	98	97	96	95
4 bar g	0.29	0.47	0.75	1.00	1.26	1.55
5 bar g	0.36	0.59	0.94	1.25	1.57	1.94
6 bar g	0.47	0.75	1.19	1.61	2.00	2.43
7 bar g	0.55	0.88	1.39	1.87	2.33	2.84
8 bar g	0.62	1.00	1.59	2.14	2.67	3.24
9 bar g	0.71	1.14	1.79	2.44	3.03	3.68
10 bar g	0.78	1.25	1.99	2.68	3.33	4.05
11 bar g	0.83	1.35	2.14	2.89	3.63	4.44
12 bar g	0.89	1.46	2.30	3.11	3.94	4.83

Purity %	Feed-air consumption at minimum nitrogen flow rate in m ³ /hr ²					
	99.5	99	98	97	96	95
4 bar g	2.56	2.78	3.16	3.41	3.77	4.03
5 bar g	3.20	3.47	3.95	4.26	4.72	5.04
6 bar g	3.93	4.29	4.89	5.30	5.80	6.32
7 bar g	4.58	5.00	5.70	6.18	6.76	7.37
8 bar g	5.24	5.72	6.52	7.06	7.73	8.43
9 bar g	5.93	6.53	7.33	8.05	8.78	9.57
10 bar g	6.55	7.14	8.15	8.83	9.66	10.5
11 bar g	7.50	8.13	9.22	10.1	10.9	11.5
12 bar g	7.99	8.73	9.89	10.9	11.8	12.5

Maximum pressure drop <0.8 bar.

Maximum nitrogen flow rate = minimum flow rate + 10%

¹ Parker membranes separate oxygen from pressurised air. The composition of the product is determined by measuring the residual oxygen content. The nitrogen content is calculated by subtracting the residual oxygen content from 100 %. Air is composed of nitrogen (78.1%), oxygen (20.9 %), Argon (0.9 %), CO₂ (0.03 %), and some trace inert gases. Therefore it should be born in mind that the value that is normally called the nitrogen content actually is the inert gas content.

² m³/hr refers to conditions at 1013mbar(a) and 20 °C

Ambient Conditions

Ambient temperature	+2°C to +50°C
Ambient pressure	atmospheric
Air quality	clean air without contaminants

Feed-air Conditions

Maximum operating pressure	13.0 bar g
Min. / Max. operating temperature	+2°C / +50°C
Maximum oil vapour content	<0.01 mg/m ³
Particles	filtered at 0.01 µm cut off
Relative humidity	<100% (non condensing)

Flow Rate Corrections

Nitrogen flow rate at feed temperatures other than 20°C	Use bulletin S3.1.059*
Feed-air consumption at feed-air temperatures other than 20°C	Use bulletin S3.1.059*

* version number may vary, make sure to use the most recent version

Material

Housing	Aluminum
---------	----------

Services on Request

3D model CAD STEP file

Weight, Dimensions and Connections

Dimensions H x W x D	386 x 145 x 63 mm
Weight	4.0 kg
Connection inlet / outlet	G ³ / ₈ female
Vent	G ³ / ₈ female
Dimensional drawing	Refer to K3.1.349

Note

Parker membrane systems produce both nitrogen and oxygen enriched air. Nitrogen enriched air can cause suffocation and oxygen enriched air causes increased fire hazards. The oxygen enriched air is available at ambient pressure and pressure build-up of enriched oxygen at the outlet must be prevented, otherwise a serious (reversible) decrease in performance will result. The nitrogen enriched air produced should be treated as pressurised air.

HiFluxx TT304

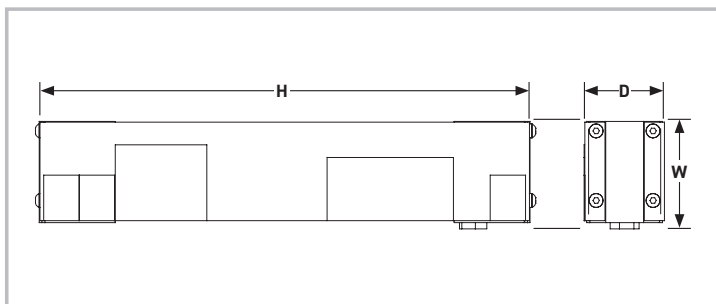

Performance data

Performance data is based on 20°C feed-air temperature and 1013 mbar ambient pressure

Purity % ¹	Minimum nitrogen flow rate in m ³ /hr ²					
	99.5	99	98	97	96	95
4 bar g	0.50	0.74	1.13	1.49	1.79	2.28
5 bar g	0.62	0.93	1.41	1.86	2.24	2.85
6 bar g	0.77	1.17	1.78	2.36	2.93	3.55
7 bar g	0.90	1.37	2.08	2.75	3.41	4.14
8 bar g	1.03	1.57	2.37	3.14	3.90	4.73
9 bar g	1.16	1.73	2.66	3.54	4.45	5.39
10 bar g	1.28	1.96	2.97	3.93	4.88	5.92
11 bar g	1.36	2.07	3.19	4.25	5.32	6.48
12 bar g	1.43	2.18	3.41	4.57	5.77	7.05

Purity %	Feed-air consumption at minimum nitrogen flow rate in m ³ /hr ²					
	99.5	99	98	97	96	95
4 bar g	3.82	4.17	4.63	5.06	5.37	5.92
5 bar g	4.78	5.21	5.79	6.33	6.71	7.40
6 bar g	5.93	6.46	7.12	7.78	8.48	9.23
7 bar g	6.92	7.53	8.30	9.07	9.90	10.8
8 bar g	7.91	8.61	9.49	10.4	11.3	12.3
9 bar g	9.01	9.71	10.9	11.7	12.9	14.0
10 bar g	10.0	11.0	12.2	13.0	14.1	15.4
11 bar g	11.6	12.4	13.7	14.9	16.0	17.5
12 bar g	12.2	13.1	14.7	16.0	17.3	19.0

Maximum pressure drop <0.8 bar.

Maximum nitrogen flow rate = minimum flow rate + 10%

¹ Parker membranes separate oxygen from pressurised air. The composition of the product is determined by measuring the residual oxygen content. The nitrogen content is calculated by subtracting the residual oxygen content from 100 %. Air is composed of nitrogen (78.1%), oxygen (20.9%), Argon (0.9%), CO₂ (0.03%), and some trace inert gases. Therefore it should be born in mind that the value that is normally called the nitrogen content actually is the inert gas content.

² m³/hr refers to conditions at 1013mbar(a) and 20 °C

Ambient Conditions

Ambient temperature	+2°C to +50°C
Ambient pressure	atmospheric
Air quality	clean air without contaminants

Feed-air Conditions

Maximum operating pressure	13.0 bar g
Min. / Max. operating temperature	+2°C / +50°C
Maximum oil vapour content	<0.01 mg/m ³
Particles	filtered at 0.01 µm cut off
Relative humidity	<100% (non condensing)

Flow Rate Corrections

Nitrogen flow rate at feed temperatures other than 20°C	Use bulletin S3.1.059*
Feed-air consumption at feed-air temperatures other than 20°C	Use bulletin S3.1.059*

* Revision number may vary, make sure to use the most recent Revision

Material

Housing	Aluminum
---------	----------

Services on Request

3D model CAD STEP file

Weight, Dimensions and Connections

Dimensions H x W x D	388 x 200 x 63 mm
Weight	5.7 kg
Connection inlet / outlet	G ³ / ₈ female
Vent	G ³ / ₈ female
Dimensional drawing	Refer to K3.1.352

Note

Parker membrane systems produce both nitrogen and oxygen enriched air. Nitrogen enriched air can cause suffocation and oxygen enriched air causes increased fire hazards. The oxygen enriched air is available at ambient pressure and pressure build-up of enriched oxygen at the outlet must be prevented, otherwise a serious (reversible) decrease in performance will result. The nitrogen enriched air produced should be treated as pressurised air.

HiFluxx ST504

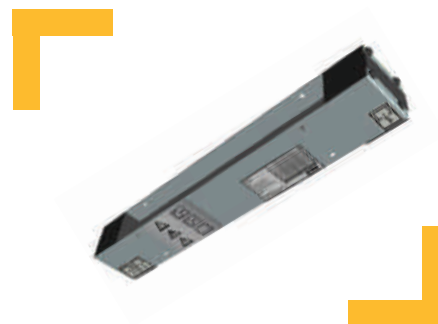
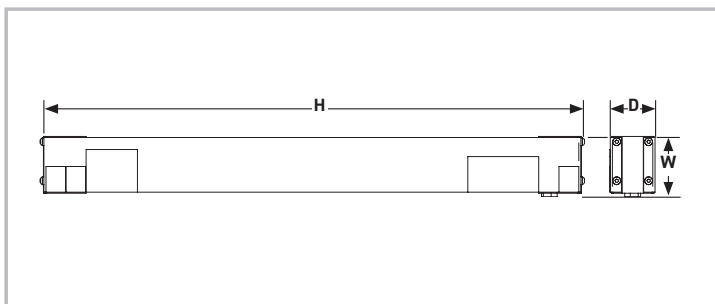

Performance data

Performance data is based on 20°C feed-air temperature and 1013 mbar ambient pressure

Purity % ¹	Minimum nitrogen flow rate in m ³ /hr ²				
	99	98	97	96	95
4 bar g	0.20	0.33	0.47	0.61	0.75
5 bar g	0.27	0.46	0.65	0.84	1.03
6 bar g	0.36	0.60	0.83	1.07	1.31
7 bar g	0.41	0.71	1.01	1.29	1.57
8 bar g	0.48	0.83	1.18	1.52	1.86
9 bar g	0.55	0.95	1.35	1.75	2.14
10 bar g	0.62	1.07	1.52	1.96	2.39
11 bar g	0.68	1.19	1.69	2.17	2.65
12 bar g	0.75	1.30	1.86	2.38	2.90
13 bar g	0.81	1.42	2.04	2.59	3.15

Purity % ¹	Feed-air consumption at minimum nitrogen flow rate in m ³ /hr ²				
	99	98	97	96	95
4 bar g	1.57	1.70	1.84	2.01	2.17
5 bar g	1.94	2.12	2.37	2.63	2.82
6 bar g	2.38	2.56	3.00	3.31	3.53
7 bar g	2.78	3.06	3.54	3.81	4.17
8 bar g	3.24	3.55	4.13	4.45	4.91
9 bar g	3.73	4.06	4.72	5.12	5.66
10 bar g	4.23	4.60	5.33	5.77	6.35
11 bar g	4.78	5.19	5.97	6.46	7.06
12 bar g	5.39	5.83	6.64	7.21	7.78
13 bar g	6.07	6.55	7.36	8.03	8.53

Maximum pressure drop <0.3 bar.

Maximum nitrogen flow rate = minimum flow rate + 30%.

¹ Parker membranes separate oxygen from pressurised air. The composition of the product is determined by measuring the residual oxygen content. The nitrogen content is calculated by subtracting the residual oxygen content from 100 %. Air is composed of nitrogen (78.1%), oxygen (20.9 %), Argon (0.9 %), CO₂ (0.03 %), and some trace inert gases. Therefore it should be born in mind that the value that is normally called the nitrogen content actually is the inert gas content.

² m³/hr refers to conditions at 1013mbar(a) and 20 °C

Ambient Conditions

Ambient temperature	+2°C to +50°C
Ambient pressure	atmospheric
Air quality	clean air without contaminants

Material

Housing	Steel
Tube	Aluminum
Coating (housing)	ESPC to RAL 7035 (Light Grey)
Coating (tube)	None

Feed-air Conditions

Maximum operating pressure	13.0 bar g
Min. / Max. operating temperature	+2°C to +50°C
Maximum oil vapour content	<0.01 mg/m ³
Particles	filtered at 0.01 µm cut off
Relative humidity	<100% (non condensing)

Services Available on Request

3D model CAD STEP file
Test Report

Flow Rate Corrections

Nitrogen flow rate at feed-air temperatures other than 20°C	Use bulletin S3.1.059*
Feed-air consumption at feed-air temperatures other than 20°C	Use bulletin S3.1.059*

* Revision number may vary, make sure to use the most recent Revision

Note

Parker membrane systems produce both nitrogen and oxygen enriched air. Nitrogen enriched air can cause suffocation and oxygen enriched air causes increased fire hazards. The oxygen enriched air is available at ambient pressure and pressure build-up of enriched oxygen at the outlet must be prevented, otherwise a serious (reversible) decrease in performance will result. The nitrogen enriched air produced should be treated as pressurised air.

HiFluxx ST604

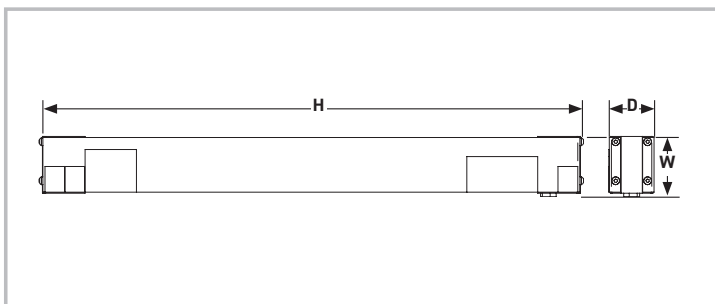

Performance data

Performance data is based on 20°C feed-air temperature and 1013 mbar ambient pressure

Purity % ¹	Minimum nitrogen flow rate in m ³ /hr ²				
	99	98	97	96	95
4 bar g	0.39	0.65	0.88	1.11	1.40
5 bar g	0.48	0.81	1.10	1.39	1.74
6 bar g	0.61	1.05	1.42	1.80	2.19
7 bar g	0.72	1.22	1.66	2.10	2.56
8 bar g	0.82	1.39	1.90	2.40	2.92
9 bar g	0.93	1.61	2.19	2.77	3.39
10 bar g	1.02	1.74	2.37	3.00	3.65
11 bar g	1.12	1.91	2.62	3.33	4.07
12 bar g	1.22	2.09	2.87	3.66	4.48

Purity % ¹	Feed-air consumption at minimum nitrogen flow rate in m ³ /hr ²				
	99	98	97	96	95
4 bar g	2.47	2.80	3.09	3.34	3.63
5 bar g	3.08	3.50	3.86	4.17	4.53
6 bar g	3.81	4.39	4.83	5.21	5.70
7 bar g	4.44	5.12	5.64	6.08	6.65
8 bar g	5.08	5.86	6.44	6.95	7.60
9 bar g	5.86	6.74	7.46	8.04	8.82
10 bar g	6.45	7.32	8.06	8.69	9.50
11 bar g	7.41	8.42	9.16	9.98	10.6
12 bar g	8.05	9.18	10.0	11.0	11.7

Maximum pressure drop <0.3 bar.

Maximum nitrogen flow rate = minimum flow rate + 30%

¹ Parker membranes separate oxygen from pressurised air. The composition of the product is determined by measuring the residual oxygen content. The nitrogen content is calculated by subtracting the residual oxygen content from 100 %. Air is composed of nitrogen (78.1%), oxygen (20.9%), Argon (0.9%), CO₂ (0.03%), and some trace inert gases. Therefore it should be born in mind that the value that is normally called the nitrogen content actually is the inert gas content.

² m³/hr refers to conditions at 1013mbar(a) and 20 °C

Ambient Conditions

Ambient temperature	+2°C to +50°C
Ambient pressure	atmospheric
Air quality	clean air without contaminants

Feed-air Conditions

Maximum operating pressure	13.0 bar g
Min. / Max. operating temperature	+2°C / +50°C
Maximum oil vapour content	<0.01 mg/m ³
Particles	filtered at 0.01 µm cut off
Relative humidity	<100% (non condensing)

Flow Rate Corrections

Nitrogen flow rate at feed temperatures other than 20°C	Use bulletin S3.1.059*
Feed-air consumption at feed-air temperatures other than 20°C	Use bulletin S3.1.059*

* Revision number may vary, make sure to use the most recent Revision

Material

Housing	Aluminum
---------	----------

Services on Request

3D model CAD STEP file

Weight, Dimensions and Connections

Dimensions H x W x D	757 x 80 x 63 mm
Weight	3.2 kg
Connection inlet / outlet	G ^{3/8} female
Vent	G ^{3/8} female
Dimensional drawing	Refer to K3.1.344

Note

Parker membrane systems produce both nitrogen and oxygen enriched air. Nitrogen enriched air can cause suffocation and oxygen enriched air causes increased fire hazards. The oxygen enriched air is available at ambient pressure and pressure build-up of enriched oxygen at the outlet must be prevented, otherwise a serious (reversible) decrease in performance will result. The nitrogen enriched air produced should be treated as pressurised air.

HiFluxx DT604

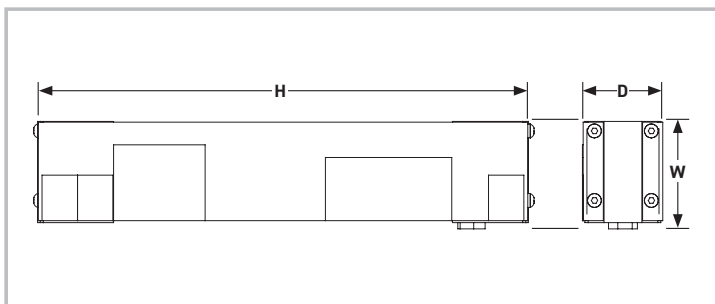

Performance data

Performance data is based on 20°C feed-air temperature and 1013 mbar ambient pressure

Purity % ¹	Minimum nitrogen flow rate in m ³ /hr ²					
	99.5	99	98	97	96	95
4 bar g	0.76	1.13	1.69	2.23	2.76	3.36
5 bar g	0.95	1.41	2.12	2.78	3.46	4.19
6 bar g	1.19	1.77	2.67	3.35	4.37	5.27
7 bar g	1.39	2.07	3.11	3.91	5.09	6.15
8 bar g	1.59	2.36	3.56	4.46	5.82	7.03
9 bar g	1.75	2.63	4.03	5.30	6.60	8.00
10 bar g	1.99	2.95	4.45	5.58	7.28	8.79
11 bar g	2.08	3.14	4.80	6.22	7.93	9.62
12 bar g	2.17	3.33	5.16	6.87	8.58	10.4

Purity %	Feed-air consumption at minimum nitrogen flow rate in m ³ /hr ²					
	99.5	99	98	97	96	95
4 bar g	5.79	6.21	6.95	7.57	8.02	8.72
5 bar g	7.24	7.77	8.69	9.46	10.0	10.9
6 bar g	8.94	9.56	10.7	11.4	12.7	13.7
7 bar g	10.4	11.2	12.5	13.3	14.8	16.0
8 bar g	11.9	12.7	14.2	15.2	16.9	18.3
9 bar g	13.3	14.5	16.1	18.0	19.1	20.8
10 bar g	15.1	16.2	17.8	19.0	21.1	22.9
11 bar g	17.3	18.5	20.2	21.2	23.8	25.0
12 bar g	18.0	19.6	21.7	23.4	25.7	27.2

Maximum pressure drop <0.8 bar.

Maximum nitrogen flow rate = minimum flow rate + 10%

¹ Parker membranes separate oxygen from pressurised air. The composition of the product is determined by measuring the residual oxygen content. The nitrogen content is calculated by subtracting the residual oxygen content from 100 %. Air is composed of nitrogen (78.1%), oxygen (20.9%), Argon (0.9%), CO₂ (0.03%), and some trace inert gases. Therefore it should be born in mind that the value that is normally called the nitrogen content actually is the inert gas content.

² m³/hr refers to conditions at 1013mbar(a) and 20 °C

Ambient Conditions

Ambient temperature	+2°C to +50°C
Ambient pressure	atmospheric
Air quality	clean air without contaminants

Feed-air Conditions

Maximum operating pressure	13.0 bar g
Min. / Max. operating temperature	+2°C / +50°C
Maximum oil vapour content	<0.01 mg/m ³
Particles	filtered at 0.01 µm cut off
Relative humidity	<100% (non condensing)

Flow Rate Corrections

Nitrogen flow rate at feed temperatures other than 20°C	Use bulletin S3.1.059*
Feed-air consumption at feed-air temperatures other than 20°C	Use bulletin S3.1.059*

* Revision number may vary, make sure to use the most recent Revision

Material

Housing	Aluminum
---------	----------

Services on Request

Material certificates EN10204-3.1 on housing material (for Stainless Steel only)

3D model CAD STEP file

Weight, Dimensions and Connections

Dimensions H x W x D	758 x 145 x 63 mm
Weight	6.0 kg
Connection inlet / outlet	G ^{3/8} female
Vent	G ^{3/8} female
Dimensional drawing	Refer to K3.1.350

Note

Parker membrane systems produce both nitrogen and oxygen enriched air. Nitrogen enriched air can cause suffocation and oxygen enriched air causes increased fire hazards. The oxygen enriched air is available at ambient pressure and pressure build-up of enriched oxygen at the outlet must be prevented, otherwise a serious (reversible) decrease in performance will result. The nitrogen enriched air produced should be treated as pressurised air.

HiFluxx TT604

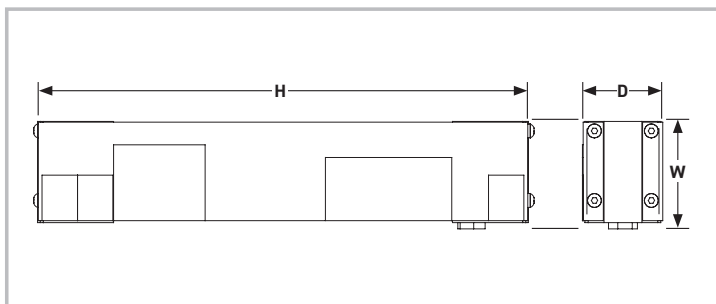

Performance data

Performance data is based on 20°C feed-air temperature and 1013 mbar ambient pressure

Purity % ¹	Minimum nitrogen flow rate in m ³ /hr ²					
	99.5	99	98	97	96	95
4 bar g	1.05	1.55	2.32	3.06	3.75	4.49
5 bar g	1.32	1.94	2.90	3.83	4.69	5.62
6 bar g	1.62	2.41	3.64	4.82	6.02	7.20
7 bar g	1.89	2.81	4.25	5.62	7.02	8.40
8 bar g	2.16	3.22	4.85	6.42	8.02	9.60
9 bar g	2.41	3.60	5.54	7.23	8.97	11.1
10 bar g	2.71	4.02	6.07	8.03	10.0	12.0
11 bar g	2.89	4.31	6.62	8.80	10.9	13.2
12 bar g	3.07	4.60	7.17	9.58	11.8	14.3

Purity %	Feed-air consumption at minimum nitrogen flow rate in m ³ /hr ²					
	99.5	99	98	97	96	95
4 bar g	8.21	8.68	9.51	10.4	11.2	12.1
5 bar g	10.3	10.8	11.9	13.0	14.1	15.2
6 bar g	12.5	13.5	14.9	16.4	17.4	18.7
7 bar g	14.6	15.8	17.4	19.1	20.4	21.8
8 bar g	16.7	18.0	19.9	21.8	23.3	25.0
9 bar g	19.3	20.5	22.7	24.6	26.9	28.8
10 bar g	21.6	22.9	24.9	27.3	30.1	31.2
11 bar g	24.6	26.3	28.5	30.8	33.8	35.6
12 bar g	26.1	28.1	30.8	33.5	36.5	38.7

Maximum pressure drop <0.8 bar.

Maximum nitrogen flow rate = minimum flow rate + 10%

¹ Parker membranes separate oxygen from pressurised air. The composition of the product is determined by measuring the residual oxygen content. The nitrogen content is calculated by subtracting the residual oxygen content from 100 %. Air is composed of nitrogen (78.1%), oxygen (20.9 %), Argon (0.9 %), CO₂ (0.03 %), and some trace inert gases. Therefore it should be born in mind that the value that is normally called the nitrogen content actually is the inert gas content.

² m³/hr refers to conditions at 1013mbar(a) and 20 °C

Ambient Conditions

Ambient temperature	+2°C to +50°C
Ambient pressure	atmospheric
Air quality	clean air without contaminants

Feed-air Conditions

Maximum operating pressure	13.0 bar g
Min. / Max. operating temperature	+2°C / +50°C
Maximum oil vapour content	<0.01 mg/m ³
Particles	filtered at 0.01 µm cut off
Relative humidity	<100% (non condensing)

Flow Rate Corrections

Nitrogen flow rate at feed temperatures other than 20°C	Use bulletin S3.1.059*
Feed-air consumption at feed-air temperatures other than 20°C	Use bulletin S3.1.059*

* Revision number may vary, make sure to use the most recent Revision

Material

Housing	Aluminum
---------	----------

Services on Request

3D model CAD STEP file

Weight, Dimensions and Connections

Dimensions H x W x D	758 x 200 x 63 mm
Weight	8.3 kg
Connection inlet / outlet	G ^{3/8} female
Vent	G ^{3/8} female
Dimensional drawing	Refer to K3.1.353

Note

Parker membrane systems produce both nitrogen and oxygen enriched air. Nitrogen enriched air can cause suffocation and oxygen enriched air causes increased fire hazards. The oxygen enriched air is available at ambient pressure and pressure build-up of enriched oxygen at the outlet must be prevented, otherwise a serious (reversible) decrease in performance will result. The nitrogen enriched air produced should be treated as pressurised air.

HiFluxx ST606

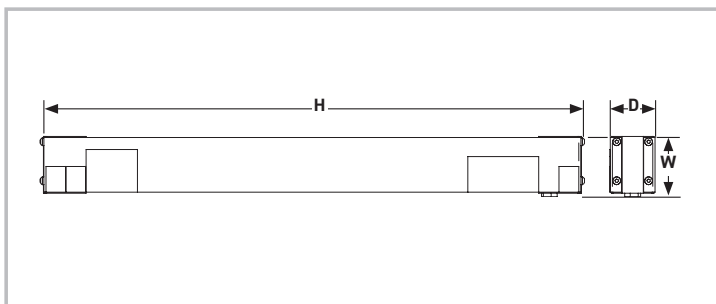

Performance data

Performance data is based on 20°C feed-air temperature and 1013 mbar ambient pressure

Purity % ¹	Minimum nitrogen flow rate in m ³ /hr ²				
	99	98	97	96	95
4 bar g	0.77	1.25	1.71	2.13	2.63
5 bar g	0.96	1.56	2.14	2.66	3.28
6 bar g	1.20	1.98	2.70	3.41	4.19
7 bar g	1.40	2.31	3.15	3.98	4.89
8 bar g	1.60	2.64	3.60	4.55	5.59
9 bar g	1.80	3.00	4.08	5.17	6.41
10 bar g	2.00	3.30	4.49	5.69	6.99
11 bar g	2.10	3.56	4.87	6.18	7.61
12 bar g	2.20	3.82	5.24	6.68	8.23

Purity %	Feed-air consumption at minimum nitrogen flow rate in m ³ /hr ²				
	99	98	97	96	95
4 bar g	4.85	5.37	5.99	6.39	6.83
5 bar g	6.07	6.72	7.49	7.99	8.54
6 bar g	7.45	8.52	9.44	10.24	10.9
7 bar g	8.69	9.94	11.0	11.9	12.7
8 bar g	9.93	11.4	12.6	13.6	14.5
9 bar g	11.3	12.9	14.3	15.5	16.7
10 bar g	12.6	14.2	15.7	17.1	18.2
11 bar g	14.5	16.0	17.5	19.2	20.5
12 bar g	15.2	17.2	18.9	20.7	22.2

Maximum pressure drop <0.3 bar.

Maximum nitrogen flow rate = minimum flow rate + 30%

¹ Parker membranes separate oxygen from pressurised air. The composition of the product is determined by measuring the residual oxygen content. The nitrogen content is calculated by subtracting the residual oxygen content from 100 %. Air is composed of nitrogen (78.1%), oxygen (20.9 %), Argon (0.9 %), CO₂ (0.03 %), and some trace inert gases. Therefore it should be born in mind that the value that is normally called the nitrogen content actually is the inert gas content.

² m³/hr refers to conditions at 1013mbar(a) and 20 °C

Ambient Conditions

Ambient temperature	+2°C to +50°C
Ambient pressure	atmospheric
Air quality	clean air without contaminants

Material

Connection block	Aluminium
Tube	PVC

Feed-air Conditions

Maximum operating pressure	13.0 bar g
Min. / Max. operating temperature	+2°C / +50°C
Maximum oil vapour content	<0.01 mg/m ³
Particles	filtered at 0.01 µm cut off
Relative humidity	<100% (non condensing)

Services on Request

3D model CAD STEP file

Flow Rate Corrections

Nitrogen flow rate at feed temperatures other than 20°C	Use bulletin S3.1.059*
Feed-air consumption at feed-air temperatures other than 20°C	Use bulletin S3.1.059*

* Revision number may vary, make sure to use the most recent Revision

Weight, Dimensions and Connections

Dimensions H x W x D	751 x 110 x 84 mm
Weight	6.4 kg
Connection inlet / outlet	G½ female
Vent	G½ female
Dimensional drawing	Refer to K3.1.345

Note

Parker membrane systems produce both nitrogen and oxygen enriched air. Nitrogen enriched air can cause suffocation and oxygen enriched air causes increased fire hazards. The oxygen enriched air is available at ambient pressure and pressure build-up of enriched oxygen at the outlet must be prevented, otherwise a serious (reversible) decrease in performance will result. The nitrogen enriched air produced should be treated as pressurised air.

HiFluxx TT606

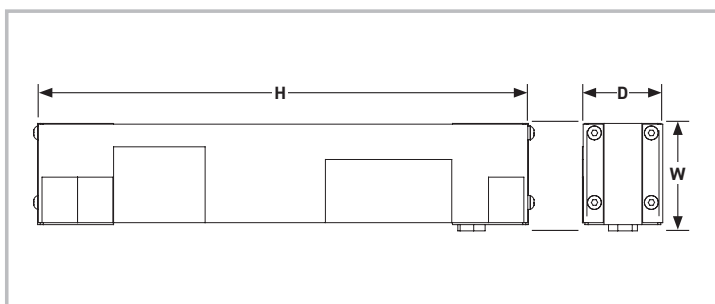

Performance data

Performance data is based on 20°C feed-air temperature and 1013 mbar ambient pressure

Purity % ¹	Minimum nitrogen flow rate in m ³ /hr ²					
	99.5	99	98	97	96	95
4 bar g	1.90	2.74	4.12	5.40	6.70	8.07
5 bar g	2.38	3.42	5.15	6.75	8.38	10.1
6 bar g	2.93	4.34	6.53	8.64	10.6	12.8
7 bar g	3.42	5.06	7.62	10.1	12.4	15.0
8 bar g	3.91	5.78	8.71	11.5	14.2	17.1
9 bar g	4.48	6.63	10.1	13.3	16.4	19.5
10 bar g	4.89	7.23	10.9	14.4	17.7	21.4
11 bar g	5.27	7.88	12.0	15.8	19.7	23.8
12 bar g	5.65	8.54	13.1	17.2	21.6	26.2

Purity %	Feed-air consumption at minimum nitrogen flow rate in m ³ /hr ²					
	99.5	99	98	97	96	95
4 bar g	15.0	15.9	17.7	18.9	20.1	21.8
5 bar g	18.8	19.9	22.1	23.6	25.1	27.2
6 bar g	22.9	24.7	26.8	29.4	31.9	33.4
7 bar g	26.7	28.8	31.2	34.3	37.3	39.0
8 bar g	30.5	33.0	35.7	39.2	42.6	44.5
9 bar g	35.0	37.8	41.2	45.1	49.3	52.6
10 bar g	38.2	41.2	44.6	49.0	53.2	57.8
11 bar g	44.8	47.3	51.6	55.4	61.0	64.3
12 bar g	48.0	51.2	56.5	60.3	66.9	70.7

Maximum pressure drop <0.8 bar.

Maximum nitrogen flow rate = minimum flow rate + 10%

¹ Parker membranes separate oxygen from pressurised air. The composition of the product is determined by measuring the residual oxygen content. The nitrogen content is calculated by subtracting the residual oxygen content from 100 %. Air is composed of nitrogen (78.1%), oxygen (20.9%), Argon (0.9%), CO₂ (0.03%), and some trace inert gases. Therefore it should be born in mind that the value that is normally called the nitrogen content actually is the inert gas content.

² m³/hr refers to conditions at 1013mbar(a) and 20 °C

Ambient Conditions

Ambient temperature	+2°C to +50°C
Ambient pressure	atmospheric
Air quality	clean air without contaminants

Material

Connection block	Aluminum
Tube	PVC

Feed-air Conditions

Maximum operating pressure	13.0 bar g
Min. / Max. operating temperature	+2°C / +50°C
Maximum oil vapour content	<0.01 mg/m ³
Particles	filtered at 0.01 µm cut off
Relative humidity	<100% (non condensing)

Services on Request

3D model CAD STEP file

Flow Rate Corrections

Nitrogen flow rate at feed temperatures other than 20°C	Use bulletin S3.1.059*
Feed-air consumption at feed-air temperatures other than 20°C	Use bulletin S3.1.059*

* Revision number may vary, make sure to use the most recent Revision

Weight, Dimensions and Connections

Dimensions H x W x D	751 x 270 x 83 mm
Weight	15 kg
Connection inlet / outlet	G½ female
Vent	G½ female
Dimensional drawing	Refer to K3.1.354

Note

Parker membrane systems produce both nitrogen and oxygen enriched air. Nitrogen enriched air can cause suffocation and oxygen enriched air causes increased fire hazards. The oxygen enriched air is available at ambient pressure and pressure build-up of enriched oxygen at the outlet must be prevented, otherwise a serious (reversible) decrease in performance will result. The nitrogen enriched air produced should be treated as pressurised air.

HiFluxx ST608

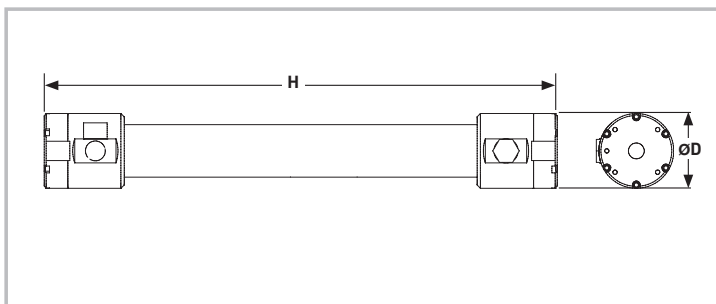

Performance data

Performance data is based on 20°C feed-air temperature and 1013 mbar ambient pressure

Purity % ¹	Minimum nitrogen flow rate in m ³ /hr ²				
	99	98	97	96	95
4 bar g	1.34	2.25	3.07	3.87	4.82
5 bar g	1.67	2.81	3.84	4.84	6.02
6 bar g	2.14	3.72	4.99	6.48	7.91
7 bar g	2.49	4.34	5.82	7.56	9.23
8 bar g	2.85	4.96	6.65	8.65	10.6
9 bar g	3.36	5.81	7.85	10.0	12.2
10 bar g	3.56	6.21	8.32	10.8	13.2
11 bar g	4.01	6.96	9.46	12.2	14.9
12 bar g	4.46	7.71	10.6	13.5	16.6

Purity %	Feed-air consumption at minimum nitrogen flow rate in m ³ /hr ²				
	99	98	97	96	95
4 bar g	9.08	10.1	11.1	12.0	13.0
5 bar g	11.4	12.7	13.8	15.0	16.3
6 bar g	14.1	16.0	17.5	19.5	20.6
7 bar g	16.5	18.7	20.4	22.7	24.0
8 bar g	18.8	21.3	23.3	25.9	27.4
9 bar g	21.8	25.0	27.5	30.0	31.8
10 bar g	23.2	26.7	29.1	32.4	34.3
11 bar g	27.7	31.3	34.1	36.5	40.2
12 bar g	30.8	34.7	38.2	40.6	44.9

Maximum pressure drop <0.3 bar.

Maximum nitrogen flow rate = minimum flow rate + 30%

¹ Parker membranes separate oxygen from pressurised air. The composition of the product is determined by measuring the residual oxygen content. The nitrogen content is calculated by subtracting the residual oxygen content from 100 %. Air is composed of nitrogen (78.1%), oxygen (20.9 %), Argon (0.9 %), CO₂ (0.03 %), and some trace inert gases. Therefore it should be born in mind that the value that is normally called the nitrogen content actually is the inert gas content.

² m³/hr refers to conditions at 1013mbar(a) and 20 °C

Ambient Conditions

Ambient temperature	+2°C to +50°C
Ambient pressure	atmospheric
Air quality	clean air without contaminants

Feed-air Conditions

Maximum operating pressure	13.0 bar g
Min. / Max. operating temperature	+2°C / +50°C
Maximum oil vapour content	<0.01 mg/m ³
Particles	filtered at 0.01 µm cut off
Relative humidity	<100% (non condensing)

Flow Rate Corrections

Nitrogen flow rate at feed temperatures other than 20°C	Use bulletin S3.1.059*
Feed-air consumption at feed-air temperatures other than 20°C	Use bulletin S3.1.059*

* Revision number may vary, make sure to use the most recent Revision

Material

Housing	Aluminum
---------	----------

Services on Request

3D model CAD STEP file

Weight, Dimensions and Connections

Dimensions H x Ø D	736 x 114 mm
Weight	5.3 kg
Connection inlet / outlet	G¾ female
Vent	G1 female
Dimensional drawing	Refer to K3.1.346

Note

Parker membrane systems produce both nitrogen and oxygen enriched air. Nitrogen enriched air can cause suffocation and oxygen enriched air causes increased fire hazards. The oxygen enriched air is available at ambient pressure and pressure build-up of enriched oxygen at the outlet must be prevented, otherwise a serious (reversible) decrease in performance will result. The nitrogen enriched air produced should be treated as pressurised air.

HiFluxx ST704

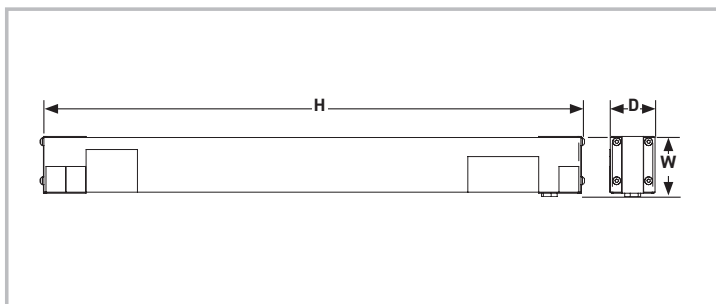

Performance data

Performance data is based on 20°C feed-air temperature and 1013 mbar ambient pressure

Purity % ¹	Minimum nitrogen flow rate in m ³ /hr ²				
	99	98	97	96	95
4 bar g	0.25	0.52	0.79	1.05	1.30
5 bar g	0.37	0.73	1.09	1.42	1.75
6 bar g	0.47	0.92	1.37	1.81	2.26
7 bar g	0.65	1.16	1.67	2.18	2.69
8 bar g	0.72	1.33	1.95	2.50	3.05
9 bar g	0.87	1.55	2.22	2.86	3.50
10 bar g	0.96	1.72	2.47	3.19	3.90
11 bar g	1.05	1.89	2.73	3.51	4.30
12 bar g	1.14	2.05	2.97	3.83	4.69
13 bar g	1.22	2.22	3.21	4.14	5.07

Purity % ¹	Feed-air consumption at minimum nitrogen flow rate in m ³ /hr ²				
	99	98	97	96	95
4 bar g	2.32	2.81	3.21	3.53	3.87
5 bar g	3.08	3.71	4.21	4.58	4.96
6 bar g	3.67	4.47	5.12	5.65	6.21
7 bar g	5.08	5.54	6.09	6.66	7.26
8 bar g	5.60	6.35	7.08	7.61	8.21
9 bar g	6.77	7.36	8.08	8.70	9.41
10 bar g	7.51	8.20	9.03	9.71	10.5
11 bar g	8.26	9.06	9.99	10.7	11.6
12 bar g	9.05	9.91	10.9	11.8	12.7
13 bar g	10.1	10.9	11.9	12.9	14.0

Maximum pressure drop <0.3 bar.

Maximum nitrogen flow rate = minimum flow rate + 30%.

¹ Parker membranes separate oxygen from pressurised air. The composition of the product is determined by measuring the residual oxygen content. The nitrogen content is calculated by subtracting the residual oxygen content from 100 %. Air is composed of nitrogen (78.1%), oxygen (20.9%), Argon (0.9%), CO₂ (0.03%), and some trace inert gases. Therefore it should be born in mind that the value that is normally called the nitrogen content actually is the inert gas content.

² m³/hr refers to conditions at 1013mbar(a) and 20 °C

Ambient Conditions

Ambient temperature	+2°C to +50°C
Ambient pressure	atmospheric
Air quality	clean air without contaminants

Material

Housing	Steel
Tube	Aluminum
Coating (housing)	ESPC to RAL 7035 (Light Grey)
Coating (tube)	None

Feed-air Conditions

Maximum operating pressure	13.0 bar g
Min. / Max. operating temperature	+2°C to +50°C
Maximum oil vapour content	<0.01 mg/m ³
Particles	filtered at 0.01 µm cut off
Relative humidity	<100% (non condensing)

Services on Request

3D model CAD STEP file
Test Report

Flow Rate Corrections

Nitrogen flow rate at feed-air temperatures other than 20°C	Use bulletin S3.1.059*
Feed-air consumption at feed-air temperatures other than 20°C	Use bulletin S3.1.059*

* Revision number may vary, make sure to use the most recent Revision

Note

Parker membrane systems produce both nitrogen and oxygen enriched air. Nitrogen enriched air can cause suffocation and oxygen enriched air causes increased fire hazards. The oxygen enriched air is available at ambient pressure and pressure build-up of enriched oxygen at the outlet must be prevented, otherwise a serious (reversible) decrease in performance will result. The nitrogen enriched air produced should be treated as pressurised air.

Weight, Dimensions and Connections

Dimensions H x W x D	804 x 80 x 63 mm
Weight	3.2 kg
Connection feed-air	G ³ / ₈ female to ISO 228
Connection nitrogen enriched air	G ³ / ₈ female to ISO 228
Connection oxygen enriched air at atmospheric pressure	G ³ / ₈ female to ISO 228
Dimensional drawing	Refer to K3.1.381

HiFluxx ST708

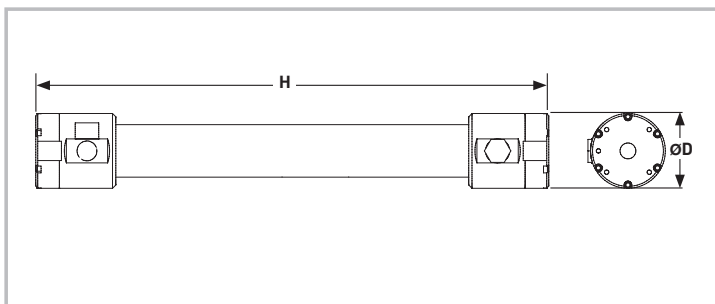

Performance data

Performance data is based on 20°C feed-air temperature and 1013 mbar ambient pressure

Purity % ¹	Minimum nitrogen flow rate in m ³ /hr ²				
	99	98	97	96	95
4 bar g	1.77	2.48	3.19	4.14	5.09
5 bar g	1.91	3.25	4.58	5.79	7.00
6 bar g	2.21	3.99	5.76	7.30	8.84
7 bar g	2.53	4.57	6.61	8.71	10.8
8 bar g	2.99	5.27	7.56	10.1	12.6
9 bar g	3.29	6.11	8.93	11.8	14.8
10 bar g	3.69	6.84	9.99	13.2	16.4
11 bar g	4.07	7.70	11.3	14.9	18.4
12 bar g	4.46	8.43	12.4	16.3	20.2
13 bar g	4.72	9.16	13.6	17.8	22.1

Purity %	Feed-air consumption at minimum nitrogen flow rate in m ³ /hr ²				
	99	98	97	96	95
4 bar g	13.8	12.6	12.5	13.6	14.8
5 bar g	13.6	15.3	17.0	18.1	19.4
6 bar g	15.0	18.3	20.8	22.2	23.7
7 bar g	16.9	20.8	23.7	26.3	28.8
8 bar g	20.0	24.0	27.1	30.5	33.6
9 bar g	22.0	27.8	32.0	35.8	39.3
10 bar g	25.2	31.3	35.8	40.0	43.9
11 bar g	28.3	35.4	40.7	45.1	49.2
12 bar g	31.7	39.4	45.1	50.0	54.7
13 bar g	34.2	43.4	50.0	55.3	60.3

Maximum pressure drop <0.3 bar.

Maximum nitrogen flow rate = minimum flow rate + 30%

¹ Parker membranes separate oxygen from pressurised air. The composition of the product is determined by measuring the residual oxygen content. The nitrogen content is calculated by subtracting the residual oxygen content from 100%. Air is composed of nitrogen (78.1%), oxygen (20.9%), Argon (0.9%), CO₂ (0.03%), and some trace inert gases. Therefore it should be born in mind that the value that is normally called the nitrogen content actually is the inert gas content.

² m³/hr refers to conditions at 1013mbar(a) and 20 °C

Ambient Conditions

Ambient temperature	+2°C to +50°C
Ambient pressure	atmospheric
Air quality	clean air without contaminants

Material

Housing	Aluminum
Coating	None

Feed-air Conditions

Maximum operating pressure	13.0 bar g
Min. / Max. operating temperature	+2°C / +50°C
Maximum oil vapour content	<0.01 mg/m ³
Particles	filtered at 0.01 µm cut off
Relative humidity	<100% (non condensing)

Services on Request

3D model CAD STEP file
Test report

Flow Rate Corrections

Nitrogen flow rate at feed temperatures other than 20°C	Use bulletin S3.1.059*
Feed-air consumption at feed-air temperatures other than 20°C	Use bulletin S3.1.059*

* Revision number may vary, make sure to use the most recent Revision

Weight, Dimensions and Connections

Dimensions H x Ø D	782 x 114 mm
Weight	5.5 kg
Connection feed-air	G¾ female to ISO 228
Connection nitrogen enriched air	G¾ female to ISO 228
Connection oxygen enriched air at atmospheric pressure	G1 female to ISO 228
Dimensional drawing	Refer to K3.1.383

Note

Parker membrane systems produce both nitrogen and oxygen enriched air. Nitrogen enriched air can cause suffocation and oxygen enriched air causes increased fire hazards. The oxygen enriched air is available at ambient pressure and pressure build-up of enriched oxygen at the outlet must be prevented, otherwise a serious (reversible) decrease in performance will result. The nitrogen enriched air produced should be treated as pressurised air.

HiFluxx ST6010

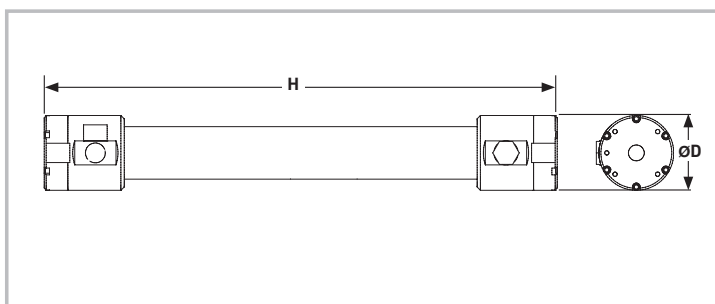

Performance data

Performance data is based on 20°C feed-air temperature and 1013 mbar ambient pressure

Purity % ¹	Minimum nitrogen flow rate in m ³ /hr ²				
	99	98	97	96	95
4 bar g	2.21	3.61	4.92	6.28	7.76
5 bar g	2.76	4.52	6.15	7.85	9.70
6 bar g	3.39	5.92	8.02	10.2	12.8
7 bar g	3.96	6.90	9.35	12.0	14.9
8 bar g	4.52	7.89	10.7	13.7	17.1
9 bar g	5.39	9.01	12.3	15.7	19.2
10 bar g	5.66	9.86	13.4	17.1	21.3
11 bar g	6.24	10.8	14.8	18.9	23.6
12 bar g	6.83	11.7	16.2	20.8	25.8

Purity %	Feed-air consumption at minimum nitrogen flow rate in m ³ /hr ²				
	99	98	97	96	95
4 bar g	14.4	16.3	17.7	19.5	21.0
5 bar g	17.9	20.3	22.1	24.3	26.2
6 bar g	22.4	25.4	28.1	30.7	33.3
7 bar g	26.1	29.7	32.7	35.9	38.8
8 bar g	29.9	33.9	37.4	41.0	44.4
9 bar g	35.1	39.6	43.0	47.0	51.9
10 bar g	36.8	43.4	46.8	51.2	57.6
11 bar g	43.7	49.7	54.7	58.7	63.6
12 bar g	47.8	54.0	60.0	64.5	69.6

Maximum pressure drop <0.3 bar.

Maximum nitrogen flow rate = minimum flow rate + 30%

¹ Parker membranes separate oxygen from pressurised air. The composition of the product is determined by measuring the residual oxygen content. The nitrogen content is calculated by subtracting the residual oxygen content from 100 %. Air is composed of nitrogen (78.1%), oxygen (20.9%), Argon (0.9%), CO₂ (0.03%), and some trace inert gases. Therefore it should be born in mind that the value that is normally called the nitrogen content actually is the inert gas content.

² m³/hr refers to conditions at 1013mbar(a) and 20 °C

Ambient Conditions

Ambient temperature	+2°C to +50°C
Ambient pressure	atmospheric
Air quality	clean air without contaminants

Mechanical Design Housing

Design pressure	15 bar g
Design temperature	50°C

membrane operating limits are lower

Feed-air Conditions

Maximum operating pressure	13.0 bar g ³
Min. / Max. operating temperature	+2°C / +50°C ³
Maximum oil vapour content	<0.01 mg/m ³
Particles	filtered at 0.01 µm cut off
Relative humidity	<100% (non condensing)

³ combination of high operating pressure and high operating temperature can reduce the life time expectancy of the membrane module

Material

Housing	Aluminum
---------	----------

Services on Request

3D model CAD STEP file

Flow Rate Corrections

Nitrogen flow rate at feed temperatures other than 20°C	Use bulletin S3.1.059*
Feed-air consumption at feed-air temperatures other than 20°C	Use bulletin S3.1.059*

* Revision number may vary, make sure to use the most recent Revision

Weight, Dimensions and Connections

Dimensions H x Ø D	736 x 139 mm
Weight	8.1 kg
Connection inlet / outlet	G1 female
Vent	G1 female
Dimensional drawing	Refer to K3.1.347

Note

Parker membrane systems produce both nitrogen and oxygen enriched air. Nitrogen enriched air can cause suffocation and oxygen enriched air causes increased fire hazards. The oxygen enriched air is available at ambient pressure and pressure build-up of enriched oxygen at the outlet must be prevented, otherwise a serious (reversible) decrease in performance will result. The nitrogen enriched air produced should be treated as pressurised air.

HiFluxx ST1506

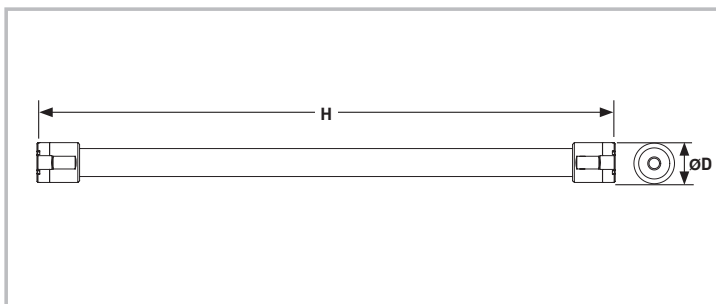

Performance data

Performance data is based on 20°C feed-air temperature and 1013 mbar ambient pressure

Purity % ¹	Minimum nitrogen flow rate in m ³ /hr ²					
	99.5	99	98	97	96	95
4 bar g	1.06	1.45	2.29	3.17	4.05	5.02
5 bar g	1.56	2.15	3.38	4.68	5.98	7.41
6 bar g	2.04	2.81	4.42	6.12	7.82	9.69
7 bar g	2.40	3.30	5.20	7.20	9.20	11.4
8 bar g	2.88	3.96	6.24	8.64	11.0	13.7
9 bar g	3.36	4.62	7.28	10.1	12.9	16.0
10 bar g	3.84	5.28	8.32	11.5	14.7	18.2
11 bar g	4.32	5.94	9.36	13.0	16.6	20.5
12 bar g	4.80	6.60	10.4	14.4	18.4	22.8
13 bar g	5.04	6.93	10.9	15.1	19.3	23.9

Purity %	Feed-air consumption at minimum nitrogen flow rate in m ³ /hr ²					
	99.5	99	98	97	96	95
4 bar g	8.98	9.15	9.84	11.1	12.1	13.0
5 bar g	13.3	13.5	14.5	16.4	17.9	19.3
6 bar g	17.3	17.7	19.0	21.4	23.5	25.2
7 bar g	20.4	20.8	22.4	25.2	27.6	29.6
8 bar g	24.5	24.9	26.8	30.2	33.1	35.6
9 bar g	28.6	29.1	31.3	35.3	38.6	41.5
10 bar g	32.6	33.3	35.8	40.3	44.2	47.4
11 bar g	36.7	37.4	40.2	45.4	49.7	53.4
12 bar g	40.8	41.6	44.7	50.4	55.2	59.3
13 bar g	42.8	43.7	47.0	52.9	58.0	62.2

Maximum pressure drop <0.3 bar.

Maximum nitrogen flow rate = minimum flow rate + 30%

¹ Parker membranes separate oxygen from pressurised air. The composition of the product is determined by measuring the residual oxygen content. The nitrogen content is calculated by subtracting the residual oxygen content from 100 %. Air is composed of nitrogen (78.1%), oxygen (20.9 %), Argon (0.9 %), CO₂ (0.03 %), and some trace inert gases. Therefore it should be born in mind that the value that is normally called the nitrogen content actually is the inert gas content.

² m³/hr refers to conditions at 1013mbar(a) and 20 °C

Ambient Conditions

Ambient temperature	+2°C to +50°C
Ambient pressure	atmospheric
Air quality	clean air without contaminants

Feed-air Conditions

Maximum operating pressure	13.0 bar g
Min. / Max. operating temperature	+2°C / +50°C
Maximum oil vapour content	<0.01 mg/m ³
Particles	filtered at 0.01 µm cut off
Relative humidity	<100% (non condensing)

Flow Rate Corrections

Nitrogen flow rate at feed temperatures other than 20°C	Use bulletin S3.1.059*
Feed-air consumption at feed-air temperatures other than 20°C	Use bulletin S3.1.059*

* Revision number may vary, make sure to use the most recent Revision

Note

Parker membrane systems produce both nitrogen and oxygen enriched air. Nitrogen enriched air can cause suffocation and oxygen enriched air causes increased fire hazards. The oxygen enriched air is available at ambient pressure and pressure build-up of enriched oxygen at the outlet must be prevented, otherwise a serious (reversible) decrease in performance will result. The nitrogen enriched air produced should be treated as pressurised air.

Mechanical Design Housing

Design pressure	15 bar g
Design temperature	65°C

membrane operating limits are lower

Material

Housing	Aluminum
---------	----------

Services on Request

Material certificates EN10204-3.1 on housing material (for Stainless Steel only)

3D model CAD STEP file

Weight, Dimensions and Connections

Dimensions H x Ø D	1655 x 100 mm
Weight	5.7 kg
Connection inlet / outlet	G¾ female
Vent	G1 female
Dimensional drawing	Refer to K3.1.334

HiFluxx DT1506-8

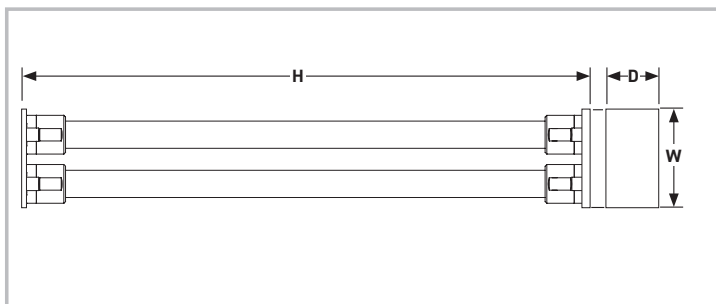

Performance data

Performance data is based on 20°C feed-air temperature and 1013 mbar ambient pressure

Purity % ¹	Minimum nitrogen flow rate in m ³ /hr ²					
	99.5	99	98	97	96	95
4 bar g	2.31	3.63	6.25	8.58	10.9	13.2
5 bar g	3.41	5.36	9.23	12.7	16.1	19.5
6 bar g	4.46	7.01	12.1	16.6	21.0	25.5
7 bar g	5.25	8.25	14.2	19.5	24.7	30.0
8 bar g	6.30	9.90	17.0	23.4	29.6	36.0
9 bar g	7.35	11.6	19.9	27.3	34.6	42.0
10 bar g	8.40	13.2	22.7	31.2	39.5	48.0
11 bar g	9.45	14.9	25.6	35.1	44.5	54.0
12 bar g	10.5	16.5	28.4	39.0	49.4	60.0
13 bar g	11.0	17.3	29.8	41.0	51.9	63.0

Purity %	Feed-air consumption at minimum nitrogen flow rate in m ³ /hr ²					
	99.5	99	98	97	96	95
4 bar g	19.6	22.9	26.9	30.0	32.6	34.3
5 bar g	29.0	33.8	39.7	44.4	48.2	50.7
6 bar g	37.9	44.2	51.9	58.0	63.0	66.3
7 bar g	44.6	52.0	61.1	68.3	74.1	78.0
8 bar g	53.6	62.4	73.3	81.9	88.9	93.6
9 bar g	62.5	72.8	85.5	95.6	104	109
10 bar g	71.4	83.2	97.7	109	119	125
11 bar g	80.3	93.6	110	123	133	140
12 bar g	89.3	104	122	137	148	156
13 bar g	93.7	109	128	143	156	164

Maximum pressure drop <0.8 bar.

Maximum nitrogen flow rate = minimum flow rate + 10%

¹ Parker membranes separate oxygen from pressurised air. The composition of the product is determined by measuring the residual oxygen content. The nitrogen content is calculated by subtracting the residual oxygen content from 100 %. Air is composed of nitrogen (78.1%), oxygen (20.9 %), Argon (0.9 %), CO₂ (0.03 %), and some trace inert gases. Therefore it should be born in mind that the value that is normally called the nitrogen content actually is the inert gas content.

² m³/hr refers to conditions at 1013mbar(a) and 20 °C

Ambient Conditions

Ambient temperature	+2°C to +50°C
Ambient pressure	atmospheric
Air quality	clean air without contaminants

Feed-air Conditions

Maximum operating pressure	13.0 bar g
Min. / Max. operating temperature	+2°C / +50°C
Maximum oil vapour content	<0.01 mg/m ³
Particles	filtered at 0.01 µm cut off
Relative humidity	<100% (non condensing)

Flow Rate Corrections

Nitrogen flow rate at feed temperatures other than 20°C	Use bulletin S3.1.059*
Feed-air consumption at feed-air temperatures other than 20°C	Use bulletin S3.1.059*

* Revision number may vary, make sure to use the most recent Revision

Mechanical Design Housing

Design pressure	13 bar g
Design temperature	50°C

membrane operating limits are lower

Material

Housing	Aluminum
---------	----------

Services on Request

Material certificates EN10204-3.1 on housing material (for Stainless Steel only)
3D model CAD STEP file

Weight, Dimensions and Connections

Model	4 - 8 bar g	9 - 13 bar g
Dimensions H x W x D (mm)	1705 x 296 x 208	1732 x 296 x 208
Weight	15 kg	15 kg
Connection inlet / outlet	G ₃ /4 female	G ₃ /4 female
Vent	G1 female	2 x G1 female
Dimensional drawing	Refer to K3.1.356	Refer to K3.1.357

Note

Parker membrane systems produce both nitrogen and oxygen enriched air. Nitrogen enriched air can cause suffocation and oxygen enriched air causes increased fire hazards. The oxygen enriched air is available at ambient pressure and pressure build-up of enriched oxygen at the outlet must be prevented, otherwise a serious (reversible) decrease in performance will result. The nitrogen enriched air produced should be treated as pressurised air.

HiFluxx ST1508

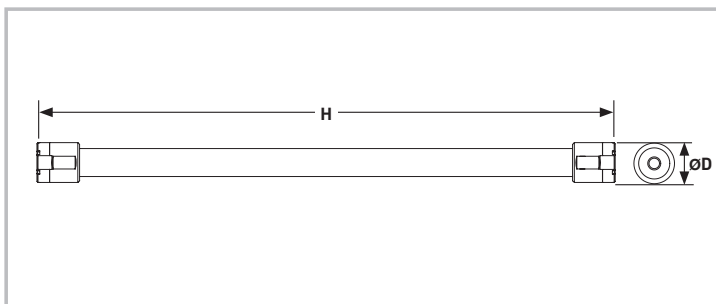

Performance data

Performance data is based on 20°C feed-air temperature and 1013 mbar ambient pressure

Purity % ¹	Minimum nitrogen flow rate in m ³ /hr ²					
	99.5	99	98	97	96	95
4 bar g	2.07	2.95	4.84	6.60	8.8	11.0
5 bar g	3.06	4.36	7.15	9.75	13.0	16.3
6 bar g	4.00	5.70	9.35	12.8	17.0	21.3
7 bar g	4.70	6.70	11.0	15.0	20.0	25.0
8 bar g	5.17	7.37	12.1	16.5	22.0	27.5
9 bar g	6.11	8.71	14.3	19.5	26.0	32.5
10 bar g	6.58	9.38	15.4	21.0	28.0	35.0
11 bar g	7.52	10.7	17.6	24.0	32.0	40.0
12 bar g	7.99	11.4	18.7	25.5	34.0	42.5
13 bar g	8.46	12.1	19.8	27.0	36.0	45.0

Purity %	Feed-air consumption at minimum nitrogen flow rate in m ³ /hr ²					
	99.5	99	98	97	96	95
4 bar g	17.6	18.6	20.8	23.1	26.4	28.6
5 bar g	26.0	27.4	30.7	34.1	39.0	42.3
6 bar g	34.0	35.9	40.2	44.6	51.0	55.3
7 bar g	40.0	42.2	47.3	52.5	60.0	65.0
8 bar g	43.9	46.4	52.0	57.8	66.0	71.5
9 bar g	51.9	54.9	61.5	68.3	78.0	84.5
10 bar g	55.9	59.1	66.2	73.5	84.0	91.0
11 bar g	63.9	67.5	75.7	84.0	96.0	104
12 bar g	67.9	71.8	80.4	89.3	102.0	111
13 bar g	71.9	76.0	85.1	94.5	108.0	117

Maximum pressure drop <0.3 bar.

Maximum nitrogen flow rate = minimum flow rate + 30%

¹ Parker membranes separate oxygen from pressurised air. The composition of the product is determined by measuring the residual oxygen content. The nitrogen content is calculated by subtracting the residual oxygen content from 100 %. Air is composed of nitrogen (78.1%), oxygen (20.9 %), Argon (0.9 %), CO₂ (0.03 %), and some trace inert gases. Therefore it should be born in mind that the value that is normally called the nitrogen content actually is the inert gas content.

² m³/hr refers to conditions at 1013mbar(a) and 20 °C

Ambient Conditions

Ambient temperature	+2°C to +50°C
Ambient pressure	atmospheric
Air quality	clean air without contaminants

Feed-air Conditions

Maximum operating pressure	13.0 bar g
Min. / Max. operating temperature	+2°C / +50°C
Maximum oil vapour content	<0.01 mg/m ³
Particles	filtered at 0.01 µm cut off
Relative humidity	<100% (non condensing)

Flow Rate Corrections

Nitrogen flow rate at feed temperatures other than 20°C	Use bulletin S3.1.059*
Feed-air consumption at feed-air temperatures other than 20°C	Use bulletin S3.1.059*

* Revision number may vary, make sure to use the most recent Revision

Note

Parker membrane systems produce both nitrogen and oxygen enriched air. Nitrogen enriched air can cause suffocation and oxygen enriched air causes increased fire hazards. The oxygen enriched air is available at ambient pressure and pressure build-up of enriched oxygen at the outlet must be prevented, otherwise a serious (reversible) decrease in performance will result. The nitrogen enriched air produced should be treated as pressurised air.

Mechanical Design Housing

Design pressure	15 bar g
Design temperature	65°C

membrane operating limits are lower

Material

Housing	Aluminum
---------	----------

Services on Request

Material certificates EN10204-3.1 on housing material (for Stainless Steel only)
3D model CAD STEP file

Weight, Dimensions and Connections

Dimensions H x Ø D	1655 x 114 mm
Weight	6.8 kg
Connection inlet / outlet	G¾ female
Vent	G1 female
Dimensional drawing	Refer to K3.1.330

HiFluxx DT1508

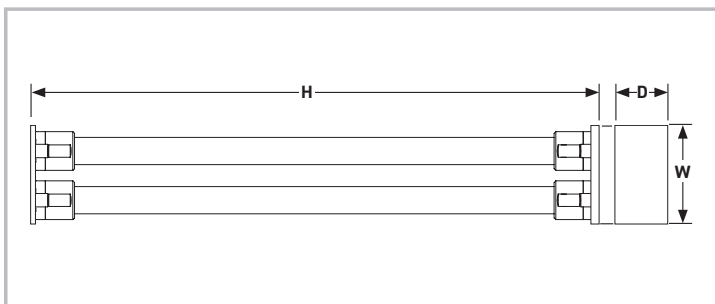

Performance data

Nitrogen Purity %	Minimum nitrogen ¹ flow rate in m ³ /hr ² (CFM) ²					
	99.5	99	98	97	96	95
4 bar g (58 psi g)	3.08 (1.81)	4.84 (2.85)	8.36 (4.92)	11.4 (6.71)	14.5 (8.53)	17.6 (10.4)
5 bar g (72.5 psi g)	4.55 (2.68)	7.15 (4.21)	12.4 (7.3)	16.9 (9.95)	21.5 (12.7)	26.0 (15.3)
6 bar g (87 psi g)	5.95 (3.5)	9.35 (5.5)	16.2 (9.53)	22.1 (13)	28.1 (16.5)	34.0 (20)
7 bar g (101.5 psi g)	7.00 (4.12)	11.0 (6.47)	19.0 (11.2)	26.0 (15.3)	33.0 (19.4)	40.0 (23.5)
8 bar g (116 psi g)	8.40 (4.94)	13.2 (7.77)	22.8 (13.4)	31.2 (18.4)	39.6 (23.3)	48.0 (28.3)
9 bar g (130.5 psi g)	9.80 (5.77)	15.4 (9.06)	26.6 (15.7)	36.4 (21.4)	46.2 (27.2)	56.0 (33)
10 bar g (145 psi g)	11.2 (6.59)	17.6 (10.4)	30.4 (17.9)	41.6 (24.5)	52.8 (31.1)	64.0 (37.7)
11 bar g (159.5 psi g)	12.6 (7.42)	19.8 (11.7)	34.2 (20.1)	46.8 (27.5)	59.4 (35)	72.0 (42.4)
12 bar g (174 psi g)	14.0 (8.24)	22.0 (12.9)	38.0 (22.4)	52.0 (30.6)	66.0 (38.8)	80.0 (47.1)
13 bar g (188.5 psi g)	14.7 (8.65)	23.1 (13.6)	39.9 (23.5)	54.6 (32.1)	69.3 (40.8)	84.0 (49.4)

Nitrogen Purity %	Feed-air consumption at minimum nitrogen flow rate in m ³ /hr ² (CFM) ²					
	99.5	99	98	97	96	95
4 bar g (58 psi g)	26.2 (15.4)	30.5 (18)	35.9 (21.1)	40.0 (23.5)	43.6 (25.7)	45.8 (27)
5 bar g (72.5 psi g)	38.7 (22.8)	45.0 (26.5)	53.1 (31.3)	59.2 (34.8)	64.4 (37.9)	67.6 (39.8)
6 bar g (87 psi g)	50.6 (29.8)	58.9 (34.7)	69.4 (40.8)	77.4 (45.6)	84.2 (49.6)	88.4 (52)
7 bar g (101.5 psi g)	59.5 (35)	69.3 (40.8)	81.7 (48.1)	91.0 (53.6)	99.0 (58.3)	104 (61.2)
8 bar g (116 psi g)	71.4 (42)	83.2 (49)	98.0 (57.7)	109 (64.2)	119 (70)	125 (73.6)
9 bar g (130.5 psi g)	83.3 (49)	97.0 (57.1)	114 (67.1)	127 (74.7)	139 (81.8)	146 (85.9)
10 bar g (145 psi g)	95.2 (56)	111 (65.3)	131 (77.1)	146 (85.9)	158 (93)	166 (97.7)
11 bar g (159.5 psi g)	107 (63)	125 (73.6)	147 (86.5)	164 (96.5)	178 (105)	187 (110)
12 bar g (174 psi g)	119 (70)	139 (81.8)	163 (95.9)	182 (107)	198 (117)	208 (122)
13 bar g (188.5 psi g)	125 (73.6)	146 (85.9)	172 (101)	191 (112)	208 (122)	218 (128)

Maximum pressure drop <0.8 bar (12 psi)
 Maximum nitrogen flow rate = minimum flow rate + 10%.
 Values between brackets are indicative imperial values

¹ Parker membranes separate oxygen from pressurised air. The composition of the product is determined by measuring the residual oxygen content. The nitrogen content is calculated by subtracting the residual oxygen content from 100%. Air is composed of nitrogen (78.1%), oxygen (20.9%), Argon (0.9%), CO₂ (0.03%), and some trace inert gases. Therefore it should be born in mind that the value that is normally called the nitrogen content actually is the inert gas content.

² m³/hr (CFM) refers to conditions at 1013 mbar(a) (14.7 psi a) and 20°C (68°F).

Ambient Conditions

Ambient temperature	+2°C to +50°C (+36°F to +122°F)
Ambient pressure	atmospheric
Air quality	clean air without contaminants

Feed-air Conditions

Maximum operating pressure	13.0 bar g (189 psi g)
Min. / Max. operating temperature	+2°C to +50°C (+36°F to +122°F)
Maximum oil vapour content	<0.01 mg/m ³ (<0.01 ppm (w))
Particles	filtered at 0.01 µm cut off
Relative humidity	<100% (non condensing)

Flow Rate Corrections

Nitrogen flow rate at feed temperatures other than 20°C (68°F)	Use bulletin S3.1.059*
Feed-air consumption at feed-air temperatures other than 20°C (68°F)	Use bulletin S3.1.059*

* Revision number may vary, make sure to use the most recent Revision

Note

Parker membrane systems produce both nitrogen and oxygen enriched air. Nitrogen enriched air can cause suffocation and oxygen enriched air causes increased fire hazards. The oxygen enriched air is available at ambient pressure and pressure build-up of enriched oxygen at the outlet must be prevented, otherwise a serious (reversible) decrease in performance will result. The nitrogen enriched air produced should be treated as pressurised air.

Mechanical Design Housing

Design pressure	13 bar g (189 psi g)
Design temperature	50°C (122°F)

Material

Housing	Aluminum
---------	----------

Services on Request

Material certificates EN10204-3.1 on housing material (for Stainless Steel only)
3D model CAD STEP file

Weight, Dimensions and Connections

Model	4 - 8 bar g (58 - 116 psi g)	9 - 13 bar g (117 - 190 psi g)
Dimensions H x W x D	1705 x 296 x 201 mm (67.1" x 11.7" x 7.9")	1705 x 296 x 145 mm (67.1" x 11.7" x 5.7")
Weight	16 kg (35.3 lb)	16 kg (35.3 lb)
Connection inlet / outlet	G¾ female to ISO 228	G¾ female to ISO 228
Vent	G1 female to ISO 228	2 x G1 female to ISO 228
Dimensional drawing	Refer to K3.1.335	Refer to K3.1.336

HiFluxx DT1508SS

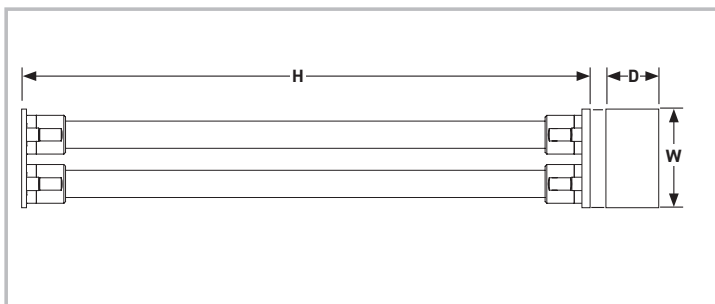

Performance data

Performance data is based on 20°C feed-air temperature and 1013 mbar ambient pressure

Purity % ¹	Minimum nitrogen flow rate in m ³ /hr ²					
	99.5	99	98	97	96	95
4 bar g	3.08	4.84	8.36	11.4	14.5	17.6
5 bar g	4.55	7.15	12.4	16.9	21.5	26.0
6 bar g	5.95	9.35	16.2	22.1	28.1	34.0
7 bar g	7.00	11.0	19.0	26.0	33.0	40.0
8 bar g	8.40	13.2	22.8	31.2	39.6	48.0
9 bar g	9.80	15.4	26.6	36.4	46.2	56.0
10 bar g	11.2	17.6	30.4	41.6	52.8	64.0
11 bar g	12.6	19.8	34.2	46.8	59.4	72.0
12 bar g	14.0	22.0	38.0	52.0	66.0	80.0
13 bar g	14.7	23.1	39.9	54.6	69.3	84.0

Purity %	Feed-air consumption at minimum nitrogen flow rate in m ³ /hr ²					
	99.5	99	98	97	96	95
4 bar g	26.2	30.5	35.9	40.0	43.6	45.8
5 bar g	38.7	45.0	53.1	59.2	64.4	67.6
6 bar g	50.6	58.9	69.4	77.4	84.2	88.4
7 bar g	59.5	69.3	81.7	91.0	99.0	104
8 bar g	71.4	83.2	98.0	109	119	125
9 bar g	83.3	97.0	114	127	139	146
10 bar g	95.2	111	131	146	158	166
11 bar g	107	125	147	164	178	187
12 bar g	119	139	163	182	198	208
13 bar g	125	146	172	191	208	218

Maximum pressure drop <0.8 bar.

Maximum nitrogen flow rate = minimum flow rate + 10%

¹ Parker membranes separate oxygen from pressurised air. The composition of the product is determined by measuring the residual oxygen content. The nitrogen content is calculated by subtracting the residual oxygen content from 100 %. Air is composed of nitrogen (78.1%), oxygen (20.9 %), Argon (0.9 %), CO₂ (0.03 %), and some trace inert gases. Therefore it should be born in mind that the value that is normally called the nitrogen content actually is the inert gas content.

² m³/hr refers to conditions at 1013mbar(a) and 20 °C

Ambient Conditions

Ambient temperature	+2°C to +50°C
Ambient pressure	atmospheric
Air quality	clean air without contaminants

Feed-air Conditions

Maximum operating pressure	13.0 bar g
Min. / Max. operating temperature	+2°C / +50°C
Maximum oil vapour content	<0.01 mg/m ³
Particles	filtered at 0.01 µm cut off
Relative humidity	<100% (non condensing)

Flow Rate Corrections

Nitrogen flow rate at feed temperatures other than 20°C	Use bulletin S3.1.059*
Feed-air consumption at feed-air temperatures other than 20°C	Use bulletin S3.1.059*

* Revision number may vary, make sure to use the most recent Revision

Mechanical Design Housing

Design pressure	15 bar g
Design temperature	65°C

membrane operating limits are lower

Material

Housing	Stainless Steel
---------	-----------------

Services on Request

Material certificates EN10204-3.1 on housing material (for Stainless Steel only)
3D model CAD STEP file

Weight, Dimensions and Connections

Model	
Dimensions H x W x D (mm)	1734 x 296 x 145
Weight	39 kg
Connection inlet / outlet	G ³ / ₄ female
Vent	2 x G1 female
Dimensional drawing	Refer to K3.1.362

Note

Parker membrane systems produce both nitrogen and oxygen enriched air. Nitrogen enriched air can cause suffocation and oxygen enriched air causes increased fire hazards. The oxygen enriched air is available at ambient pressure and pressure build-up of enriched oxygen at the outlet must be prevented, otherwise a serious (reversible) decrease in performance will result. The nitrogen enriched air produced should be treated as pressurised air.

HiFluxx ST15020-1

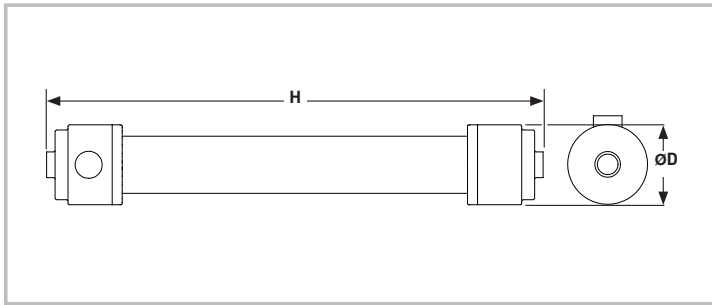

Performance data

Performance data is based on 20°C feed-air temperature and 1013 mbar ambient pressure

Purity % ¹	Typical nitrogen flow rate in m ³ /hr ²				
	99	98	97	96	95
4 bar g	24.0	39.0	53.0	71.0	89.0
5 bar g	35.0	58.0	78.0	105	131
6 bar g	46.0	75.0	103	137	171
7 bar g	54.0	89.0	121	161	201
8 bar g	59.0	97.0	133	177	221

Purity %	Feed-air consumption at typical nitrogen flow rate in m ³ /hr ²				
	99	98	97	96	95
4 bar g	161	175	191	220	239
5 bar g	238	259	283	324	353
6 bar g	289	324	359	411	445
7 bar g	340	381	423	483	523
8 bar g	374	419	465	531	576

Maximum pressure drop <0.3 bar.

¹ Parker membranes separate oxygen from pressurised air. The composition of the product is determined by measuring the residual oxygen content. The nitrogen content is calculated by subtracting the residual oxygen content from 100 %. Air is composed of nitrogen (78.1%), oxygen (20.9 %), Argon (0.9 %), CO₂ (0.03 %), and some trace inert gases. Therefore it should be born in mind that the value that is normally called the nitrogen content actually is the inert gas content.

² m³/hr refers to conditions at 1013mbar(a) and 20 °C

Above tables reflect nominal flow rates. The nitrogen output of each individual module can vary +/- 15%. For selection purposes, calculation should be done based on nominal conditions without taking the variation into account. When ordering modules, it is necessary that the total modules needed for each individual project are clearly mentioned per order-line on the order-intake-form. Parker will assure that the total output flow rate (sum of the individual selected membranes flow rates) will be minimum the total nominal flow rate. The compressor selection can be done on the total calculated nominal flow rate without taking any variation into account.

Example:

Your project requires 1515 Nm³/hr nitrogen at 8 bar g inlet pressure, 95% purity and 20°C inlet temperature. You will need 7 modules. Parker will ensure a minimum total product flow of 1515 Nm³/hr. However, individual module performance can still vary +/-15%. The compressor should be selected on a total air consumption of 7 x 576 = 4032 Nm³/hr.

Ambient Conditions

Ambient temperature	+2°C to +50°C
Ambient pressure	atmospheric
Air quality	clean air without contaminants

Feed-air Conditions

Maximum operating pressure	9.0 bar g
Min. / Max. operating temperature	+2°C / +50°C
Maximum oil vapour content	<0.01 mg/m ³
Particles	filtered at 0.01 µm cut off
Relative humidity	<100% (non condensing)

Flow Rate Corrections

Nitrogen flow rate at feed temperatures other than 20°C	Use bulletin S3.1.059*
Feed-air consumption at feed-air temperatures other than 20°C	Use bulletin S3.1.059*

* Revision number may vary, make sure to use the most recent Revision

Note

Parker membrane systems produce both nitrogen and oxygen enriched air. Nitrogen enriched air can cause suffocation and oxygen enriched air causes increased fire hazards. The oxygen enriched air is available at ambient pressure and pressure build-up of enriched oxygen at the outlet must be prevented, otherwise a serious (reversible) decrease in performance will result. The nitrogen enriched air produced should be treated as pressurised air.

Mechanical Design Housing

Design pressure	14 bar g
Design temperature	65°C

membrane operating limits are lower

Material

Housing	Aluminum
---------	----------

Services on Request

3D model CAD STEP file

Weight, Dimensions and Connections

Dimensions H x Ø D	1740 x 280 mm
Weight	46 kg
Connection inlet / outlet	G2½ female
Vent	100 mm OD
Dimensional drawing	K3.1.339*

HiFluxx ST1508SS

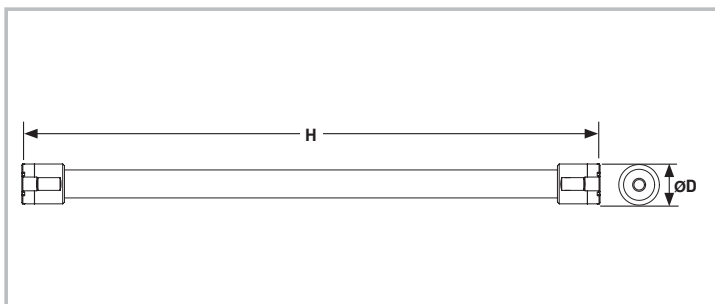

Performance data

Performance data is based on 20°C feed-air temperature and 1013 mbar ambient pressure

Purity % ¹	Minimum nitrogen flow rate in m ³ /hr ²					
	99.5	99	98	97	96	95
4 bar g	2.07	2.95	4.84	6.60	8.8	11.0
5 bar g	3.06	4.36	7.15	9.75	13.0	16.3
6 bar g	4.00	5.70	9.35	12.8	17.0	21.3
7 bar g	4.70	6.70	11.0	15.0	20.0	25.0
8 bar g	5.17	7.37	12.1	16.5	22.0	27.5
9 bar g	6.11	8.71	14.3	19.5	26.0	32.5
10 bar g	6.58	9.38	15.4	21.0	28.0	35.0
11 bar g	7.52	10.7	17.6	24.0	32.0	40.0
12 bar g	7.99	11.4	18.7	25.5	34.0	42.5
13 bar g	8.46	12.1	19.8	27.0	36.0	45.0

Purity %	Feed-air consumption at minimum nitrogen flow rate in m ³ /hr ²					
	99.5	99	98	97	96	95
4 bar g	17.6	18.6	20.8	23.1	26.4	28.6
5 bar g	26.0	27.4	30.7	34.1	39.0	42.3
6 bar g	34.0	35.9	40.2	44.6	51.0	55.3
7 bar g	40.0	42.2	47.3	52.5	60.0	65.0
8 bar g	43.9	46.4	52.0	57.8	66.0	71.5
9 bar g	51.9	54.9	61.5	68.3	78.0	84.5
10 bar g	55.9	59.1	66.2	73.5	84.0	91.0
11 bar g	63.9	67.5	75.7	84.0	96.0	104
12 bar g	67.9	71.8	80.4	89.3	102.0	111
13 bar g	71.9	76.0	85.1	94.5	108.0	117

Maximum pressure drop <0.3 bar.

Maximum nitrogen flow rate = minimum flow rate + 30%

¹ Parker membranes separate oxygen from pressurised air. The composition of the product is determined by measuring the residual oxygen content. The nitrogen content is calculated by subtracting the residual oxygen content from 100 %. Air is composed of nitrogen (78.1%), oxygen (20.9%), Argon (0.9%), CO₂ (0.03%), and some trace inert gases. Therefore it should be born in mind that the value that is normally called the nitrogen content actually is the inert gas content.

² m³/hr refers to conditions at 1013mbar(a) and 20°C

Ambient Conditions

Ambient temperature	+2°C to +50°C
Ambient pressure	atmospheric
Air quality	clean air without contaminants

Feed-air Conditions

Maximum operating pressure	13.0 bar g
Min. / Max. operating temperature	+2°C / +50°C
Maximum oil vapour content	<0.01 mg/m ³
Particles	filtered at 0.01 µm cut off
Relative humidity	<100% (non condensing)

Flow Rate Corrections

Nitrogen flow rate at feed temperatures other than 20°C	Use bulletin S3.1.059*
Feed-air consumption at feed-air temperatures other than 20°C	Use bulletin S3.1.059*

* Revision number may vary, make sure to use the most recent Revision

Mechanical Design Housing

Design pressure	15 bar g
Design temperature	65°C

membrane operating limits are lower

Material

Housing	Stainless Steel
---------	-----------------

Services on Request

Material certificates EN10204-3.1 on housing material (for Stainless Steel only)
3D model CAD STEP file

Weight, Dimensions and Connections

Dimensions H x Ø D	1654 x 114 mm
Weight	18 kg
Connection inlet / outlet	G¾ female
Vent	G1 female
Dimensional drawing	Refer to K3.1.358

Note

Parker membrane systems produce both nitrogen and oxygen enriched air. Nitrogen enriched air can cause suffocation and oxygen enriched air causes increased fire hazards. The oxygen enriched air is available at ambient pressure and pressure build-up of enriched oxygen at the outlet must be prevented, otherwise a serious (reversible) decrease in performance will result. The nitrogen enriched air produced should be treated as pressurised air.

Correction Factors HiFluxx

Temperature has influence on the performance of the Parker membranes. As the temperature changes so does the membrane performance. As a consequence the capacity and feed-air factor differ from the ones at nominal temperature (20°C).

Hereafter are the tables with correction factors for temperatures differing from 20°C for the HiFluxx membrane modules.

Table 1

Temperature	Nitrogen flow rate correction factor for HiFluxx at various product concentrations ¹⁾					
	99.5	99	98	97	96	95
5°C	0.9	0.9	0.9	0.9	0.9	0.9
10°C	0.9	0.9	0.9	0.9	0.9	0.9
30°C	1.0	1.0	1.0	1.0	1.0	1.0
40°C	0.6	0.8	1.0	1.0	1.1	1.1
50°C	0.6	0.8	1.0	1.1	1.1	1.2

Table 2

Temperature	Feed-Air consumption correction factor for HiFluxx at various product concentrations ¹⁾					
	99.5	99	98	97	96	95
5°C	0.8	0.8	0.8	0.8	0.8	0.8
10°C	0.9	0.9	0.9	0.9	0.9	0.9
30°C	1.1	1.1	1.1	1.1	1.1	1.1
40°C	1.2	1.2	1.2	1.2	1.2	1.2
50°C	1.3	1.3	1.3	1.3	1.3	1.3

¹⁾ These numbers are indicative and may vary by +/- 0.1

Example

Sizing conditions	
Inlet pressure	7 bar _g
Nitrogen purity	97%
Feed-air temperature	50°C
N2 correction factor	1.1 (table 1)
Feed-air correction factor	1.3 (table 2)
Module	HiFluxx ST1508
N2 flow rate HiFluxx ST1508	15 m ³ /hr (at 20°C)
Feed-air consumption HiFluxx ST1508	52.5 m ³ /hr (at 20°C)

Corrected Nitrogen Flow Calculation at 50°C and 97%

Corrected nitrogen flow: 15 m³/hr x 1.1 = 16.5 m³/hr

Corrected Feed-Air Calculation at 50°C and 97%

Corrected feed-air flow: 52.5 m³/hr x 1.3 = 68.3 m³/hr

PCO2 Carbon Dioxide Quality Incident Protection Systems

From production plant to fountain / post mix and beer dispense, guaranteed CO₂ purity is assured.

The PCO2 Carbon Dioxide Quality Incident Protection System from Parker offers a comprehensive solution to preserve and guarantee the quality of gaseous carbon dioxide used in the sparkling beverage industry.

Using multi-layer gas adsorbent technology, the PCO2 range includes models for plant scale protection, as well as smaller variants for fountain / post mix and beer dispense applications respectively.

Operating as a vapour absorber to remove a wide range of potentially harmful carbon dioxide impurities, the system guarantees the gas quality to remain within industry and company guidelines, therefore preventing detrimental consequences to the finished beverage and to the producers reputation.

PCO2 quality incident production systems for production plant

The system for the production plant environment offers in-line quality incident protection against peak levels of trace impurities which may be present in beverage-grade carbon dioxide.

Typical production plant application

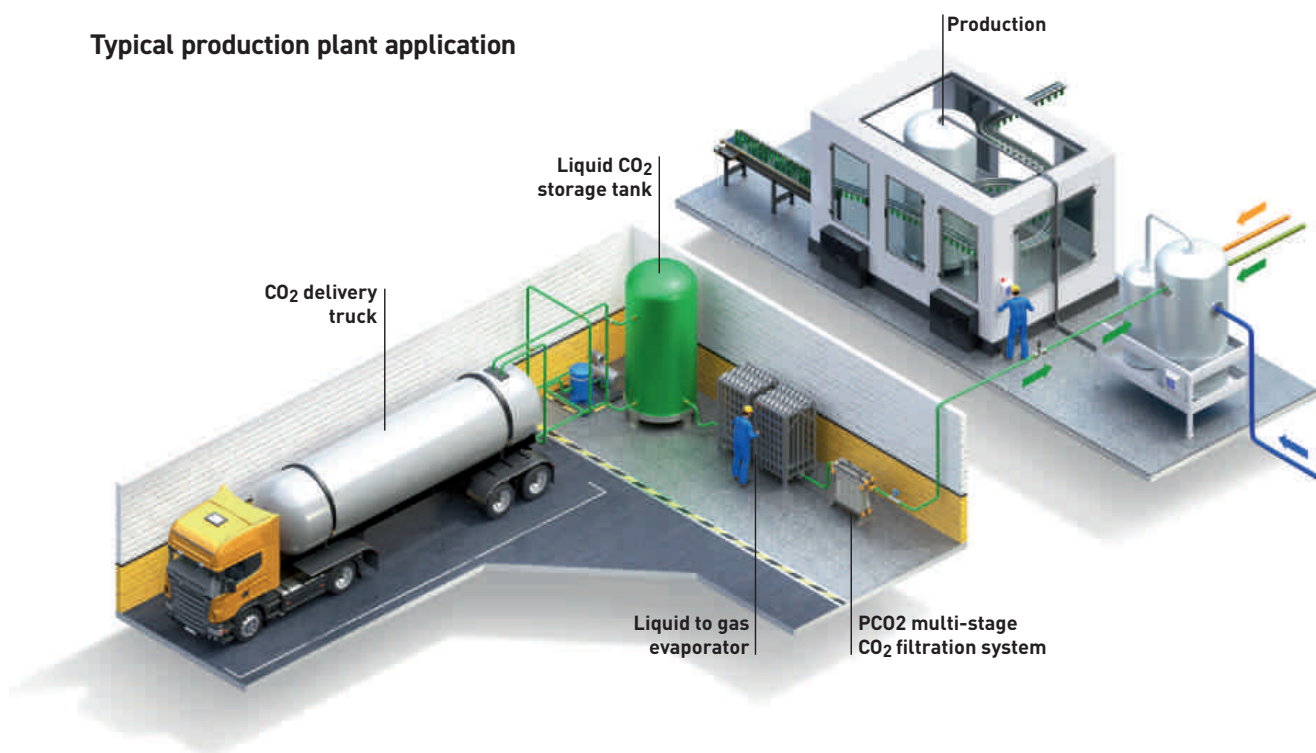

Nitrogen Quality Incident Protection

Whilst originally developed for the protection of carbon dioxide quality used in the beverage industry, the Parker PCO2 system is also effective at removing trace levels of hydrocarbon contamination from nitrogen gas.

As part of the gas Quality Incident Protection System, the PCO2 system can be used in a wide range of industries where the quality of the gas is critical i.e. life science research, bio-pharmaceutical, laboratory gases and electronics.

ISBT Quality Guidelines for Carbon Dioxide

The International Society of Beverage Technologists (ISBT) is the only organisation whose sole interest is the technical and scientific aspects of soft drinks and beverages.

The ISBT is a highly respected body which is dedicated to the promotion, development and dissemination of knowledge relating to the art and science of beverage technology.

The quality guidelines and analytical procedure bibliography has been developed by the ISBT to provide guidance for manufacturers of carbonated beverages and suppliers of carbon dioxide to the carbonated beverage industries about key characteristics for the quality and purity of carbon dioxide when used as a direct food additive in beverages.

The following table lists the voluntary quality standards taken from the document with relation to CO₂ quality.

Voluntary quality standards as listed in the ISBT Quality Guidelines

Parameter	Guideline	Rationale†
Purity:	99.9 % v/v min.	Process
Moisture:	20 ppm v/v max.	Process
Oxygen:	30 ppm v/v max.	Sensory
Carbon Monoxide:	10 ppm v/v max.	Process
Ammonia	2.5 ppm v/v max.	Process
Nitric Oxide / Nitrogen Dioxide:	2.5 ppm v/v max. (each)	Regulatory
Non-volatile Residue:	10 ppm w/w max.	Sensory
Non-volatile Organic Residue:	5 ppm w/w max.	Sensory
Phosphine:	To pass test (0.3 ppm v/v max.)	Regulatory
Total Volatile Hydrocarbons: (as Methane)	50 ppm v/v max. including 20 ppm v/v max. as total non-methane hydrocarbons	Sensory
Acetaldehyde:	0.2 ppm v/v max.	Sensory
Aromatic Hydrocarbon Content:	20 ppb v/v max.	Regulatory
Total Sulphur Content* (as S): (*Total sulphur-containing impurities excluding sulphur dioxide)	0.1 ppm v/v max.	Sensory
Sulphur Dioxide	1 ppm v/v max.	Sensory
Odour of Solid CO ₂ (snow):	No foreign odour	Sensory
Appearance in water:	No colour or turbidity	Sensory
Odour and taste in water:	No foreign odour or taste	Sensory

Source: ISBT CO₂ quality & analytical procedure bibliography, 2010.

Rationale definitions:

Sensory: Any attribute that negatively impacts the taste, appearance or odour of beverage.

Process: Any attribute that defines a key parameter in a controlled process and an important consideration in the beverage industry.

Regulatory: Any attribute whose limit is set by governing regulatory agencies.

PCO2 Carbon Dioxide Quality Incident Protection Systems

For the sparkling beverage industry

Technical Data

Model	Port Size*	Flow Rate		Quantity Required	Max Operating Pressure		Min Operating Temperature		Max Operating Temperature		Inlet CO ₂ Quality**
		Kg/h	Lb/h		bar g	psi g	°C	°F	°C	°F	
PCO2-400	1"	181	400	1	20.7	300	-20	-4	40	104	ISBT Beverage Grade CO ₂
PCO2-800	1½"	363	800	1	24.1	350	-20	-4	40	104	
PCO2-1600	1½"	726	1600	1	24.1	350	-20	-4	40	104	
PCO2-2400	1½"	1089	2400	1	24.1	350	-20	-4	40	104	
PCO2-3200	1½"	1451	3200	1	24.1	350	-20	-4	40	104	
PCO2-4000	1½"	1814	4000	1	24.1	350	-20	-4	40	104	
PCO2-4800	1½"	2177	4800	1	24.1	350	-20	-4	40	104	
PCO2-3200 Duplex*	1½"	2903	6400	2	24.1	350	-20	-4	40	104	
PCO2-4000 Duplex*	1½"	3628	8000	2	24.1	350	-20	-4	40	104	
PCO2-4800 Duplex*	1½"	4354	9600	2	24.1	350	-20	-4	40	104	

*Duplex systems are installed in parallel to double the flow.

**PCO2 CO₂ Systems are for gaseous CO₂ only.

All systems are rated at a maximum operating pressure of 24.1 bar g / 350 psi g.

Correction Factors

Inlet Pressure	bar g	3	4	5	6	7	8	9	10	11	12	13
	psi g	44	58	73	87	102	116	130	145	160	174	189
Correction factor		0.19	0.23	0.28	0.33	0.38	0.42	0.47	0.52	0.57	0.61	0.66

Inlet Pressure	bar g	14	15	16	17	18	19	20	21	22	23	24
	psi g	203	218	232	247	261	275	290	304	319	333	348
Correction factor		0.71	0.76	0.80	0.85	0.90	0.95	1	1	1	1	1

Operation

Stage 1

0.01 micron particle filtration
Removal of non-volatile organic residue (NVOR) and other contaminants down to 0.01 ppm

Stage 2

Removal of water vapour and partial removal of hydrocarbons

Stage 3

Primary removal of aromatic hydrocarbons (Benzene, Toluene etc and Acetaldehyde)

Stage 4

Removal of sulphur compounds (COS, H₂S, DMS etc)

Stage 5

0.01 micron particle filtration

Stage 6*

Point of use VBACE sterile gas membrane. Hi Flow Tetpor II

* Optional - Sterilizing Grade: consult Parker for operational use

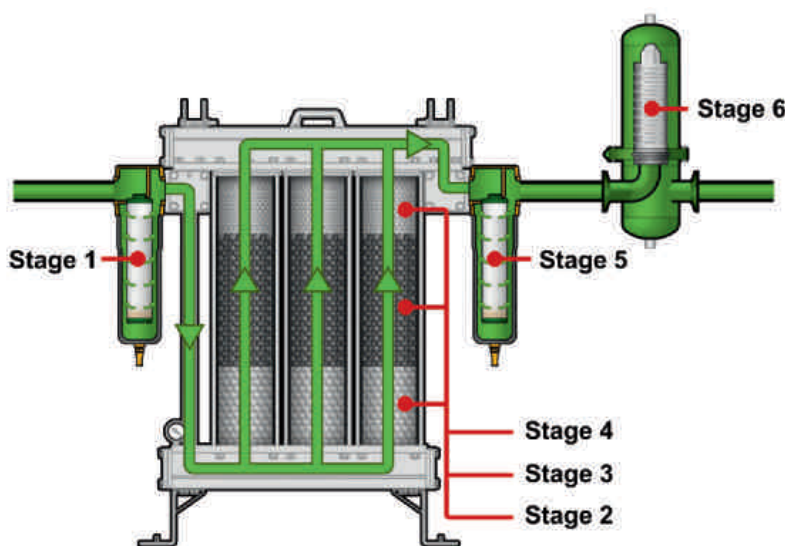

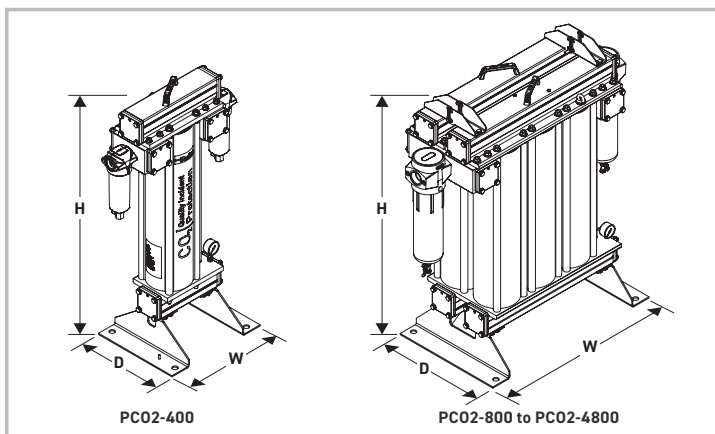

Weights and Dimensions

Model	Height (H)		Width (W)		Depth (D)		Clearance**		Weight	
	mm	ins	mm	ins	mm	ins	mm	ins	kg	lbs
PCO2-400	1035	40.8	564	22.2	350	13.7	680	27	75	165
PCO2-800	1060.7	41.8	632	24.9	450	17.7	680	27	84	185
PCO2-1600	1060.7	41.8	801	31.5	450	17.7	680	27	128	282
PCO2-2400	1060.7	41.8	970	39.4	450	17.7	680	27	172	379
PCO2-3200	1060.7	41.8	1139	44.8	450	17.7	680	27	217	478
PCO2-4000	1060.7	41.8	1308	51.5	450	17.7	680	27	260	573
PCO2-4800	1060.7	41.8	1477	58.1	450	17.7	680	27	304	670

*All systems are supplied as NPT with stainless steel adapters 'NPT to BSP' as standard.

** Clearance required for the removal and servicing of cartridges.

Preventative Maintenance Kits - Required Every 8000 Hrs (12 months)

Model	Part Number	Contents	Order Quantity
PCO2-400	MK-PCO2-400	1 x Desiccant Cartridge, 2 x Outlet Block O-Rings, 2 x P020-AA Filter Elements, 2 x Filter Bowl O-Rings	1
PCO2-800	MK-PCO2-800	2 x Desiccant Cartridges, 2 x Outlet Block O-Rings, 2 x IP50-AA Filter Elements, 2 x Filter Bowl O-Rings	1
PCO2-1600	MK-PCO2-1600	4 x Desiccant Cartridges, 2 x Outlet Block O-Rings, 2 x IP50-AA Filter Elements, 2 x Filter Bowl O-Rings	1
PCO2-2400	MK-PCO2-2400	6 x Desiccant Cartridges, 2 x Outlet Block O-Rings, 2 x IP50-AA Filter Elements, 2 x Filter Bowl O-Rings	1
PCO2-3200	MK-PCO2-3200	8 x Desiccant Cartridges, 2 x Outlet Block O-Rings, 2 x IP50-AA Filter Elements, 2 x Filter Bowl O-Rings	1
PCO2-4000	MK-PCO2-4000	10 x Desiccant Cartridges, 2 x Outlet Block O-Rings, 2 x IP50-AA Filter Elements, 2 x Filter Bowl O-Rings	1
PCO2-4800	MK-PCO2-4800	12 x Desiccant Cartridges, 2 x Outlet Block O-Rings, 2 x IP50-AA Filter Elements, 2 x Filter Bowl O-Rings	1
PCO2-3200 (Duplex)	MK-PCO2-6400	16 x Desiccant Cartridges, 4 x Outlet Block O-Rings, 4 x IP50-AA Filter Elements, 4 x Filter Bowl O-Rings	1
PCO2-4000 (Duplex)	MK-PCO2-8000	20 x Desiccant Cartridges, 4 x Outlet Block O-Rings, 4 x IP50-AA Filter Elements, 4 x Filter Bowl O-Rings	1
PCO2-4800 (Duplex)	MK-PCO2-9600	24 x Desiccant Cartridges, 4 x Outlet Block O-Rings, 4 x IP50-AA Filter Elements, 4 x Filter Bowl O-Rings	1



With OIL-X filter elements (PCO2-400 Models only)



With OIL-X IP50 filter elements (PCO2-800 to PCO2-4800 Models)

Biogas Dehumidification Systems

Installed on a hot galvanized steel frame (skid), a water chiller (Hyperchill BioEnergy), cooler (Hypercool BioEnergy) and a centrifugal separator (Hypersep BioEnergy) are the key components of the Biogas Dehumidification System: they have been specifically designed for biogas applications and provide safe, reliable operation in harsh environments typically found at AD and landfill biogas production sites.

The standard biogas dehumidification package includes water connections between Hyperchill and Hypercool, water isolating valves, a water expansion tank and a counter flange kit with gaskets for the system's connection to the customer's piping.

Standard Skid Package

Hyperchill BioEnergy (ICE series)

- Chiller Output 5 – 360 kW
- Special coating for corrosive environment
- Pump & tank installed in casing
- Microprocessor controlled
- Ambient range -20°C to +45°C
- Compliant scroll refrigerant compressor
- IP54 protection as standard



Hypercool BioEnergy (WFB Series)

- High cooling efficiency with low pressure drop design
- Material: Parts in contact with biogas are AISI304 or AISI316L, parts not in contact with biogas are AISI304
- Maximum working pressure: 0.5 barg



Hypersep BioEnergy (CSB Series)

- Cyclonic separator optimized for biogas applications
- High separation efficiency with very low pressure drop
- Material: Parts in contact with biogas are AISI304 or AISI316L
- Maximum working pressure: 0.5 barg



Optional Additions to Standard Skid Package

The standard Biogas Dehumidification System can be extended to include additional components such as a particulate filter, condensate drain and / or energy-saving, 'Gas2Gas' recuperator.

Hyperfilter BioEnergy (FFB)

- Particle removal: 5 or 20 µm
- Filtration efficiency 99.999%
- Differential pressure 2 mbar
- Material: AISI304 or AISI316L, with additional pickling and passivation treatment
- Maximum working pressure: 0.5 barg



Gas2Gas Recuperator BioEnergy (RBB)

- Free-cools incoming biogas to reduce chiller cooling load
- Free-heats outgoing biogas to reduce relative humidity thus eliminating the need for auxiliary heating
- High thermal transfer efficiency with very low pressure drop
- Material: AISI304 or AISI316L, with additional pickling and passivation treatment



Hyperdrain BioEnergy (HDF220BE)

- Designed to work with dirty condensate and for low pressure operation
- No electrical wiring
- No gas loss
- Parts in contact with condensate are stainless steel and reinforced polyamide, body treated with special Hiroshield treatment for optimal operation in harsh environments



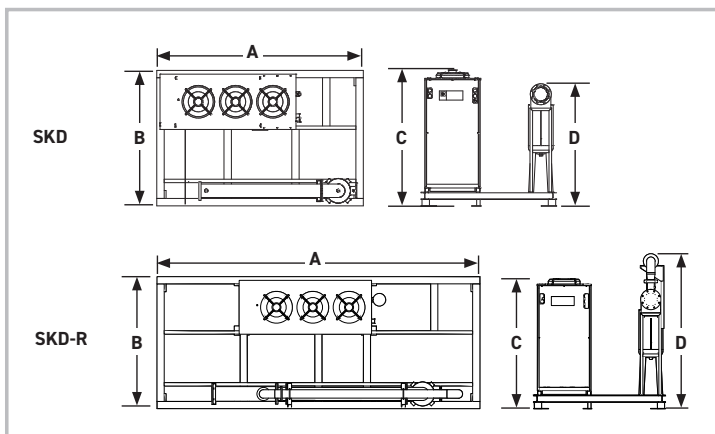

Biogas Dehumidification System

Model	Biogas Flow Rate (m³/h)	Gas Inlet Conns.	Gas Outlet Conns.	Condensate Removed (kg/h)	Dimensions								Weight*	
					A		B		C		D*		kg	lbs
					mm	ins	mm	ins	mm	ins	mm	ins		
skd60-007	60	DN80	DN50	3.1	2500	98.4	1700	66.9	1615	63.6	1640	64.6	558	1228
skd105-010	105	DN80	DN50	5.3	2500	98.4	1700	66.9	1615	63.6	1640	64.6	638	1404
skd165-014	165	DN125	DN80	8.4	2500	98.4	1700	66.9	1615	63.6	1635	64.4	690	1518
skd265-024	265	DN125	DN80	13.5	2500	98.4	1700	66.9	1615	63.6	1635	64.4	795	1749
skd240-030	240	DN125	DN80	12.8	3300	129.9	1800	70.9	1615	63.6	1695	66.7	880	1936
skd360-040	360	DN200	DN125	19.2	3300	129.9	1800	70.9	1890	74.4	1975	77.8	941	2070
skd510-060	510	DN200	DN125	27.2	3300	129.9	1800	70.9	1890	74.4	1975	77.8	1166	2565
skd720-076	720	DN200	DN125	38.4	3350	131.9	2200	86.6	2214	87.2	1995	78.5	1451	3192
skd1110-116	1110	DN300	DN200	59.2	3350	131.9	2200	86.6	2214	87.2	2102	82.8	1732	3810
skd1620-116	1350	DN300	DN200	71.6	3350	131.9	2200	86.6	2214	87.2	2102	82.8	1788	3934

Performances refer to operation with clean cooler and separator, gas flow rate at 20°C (68°F) / 1 barA. Nominal working conditions: 60% CH₄, 40% CO₂, gas inlet temperature 40°C (104°F) saturated, refrigerant inlet water temperature 1°C (34°F), ambient temperature 35°C (95°F), gas outlet temperature at nominal conditions 8°C (46°F) (from model skd60-007 to model skd265-024) and 4°C (39°F) (from model skd240-030 to model skd1620-116). Average pressure drop without filter 11 mbar +/- 2 for all models. average pressure drops with filter 14 mbar +/- 2 for all models.

*Data refers to skid without filter.

Biogas Dehumidification System with 'Gas2Gas' Recuperator

Model	Biogas Flow Rate (m³/h)	Gas Inlet Conns.	Gas Outlet Conns.	Condensate Removed (kg/h)	Dimensions								Weight*	
					A		B		C		D*		kg	lbs
					mm	ins	mm	ins	mm	ins	mm	ins		
skd60-007-R	60	DN80	DN40	3.1	3750	147.6	1700	66.9	1615	63.6	1982	78.0	703	1547
skd105-010-R	105	DN80	DN40	5.4	3750	147.6	1700	66.9	1625	64.0	1982	78.0	711	1564
skd165-014-R	165	DN125	DN50	8.5	3750	147.6	1700	66.9	1615	63.6	2040	80.3	772	1698
skd265-024-R	265	DN125	DN50	13.5	3750	147.6	1700	66.9	1615	63.6	2040	80.3	785	1727
skd240-030-R	240	DN125	DN50	12.8	4900	192.9	1800	70.9	1615	63.6	2100	82.7	1089	2396
skd360-040-R	360	DN200	DN100	19.3	4900	192.9	1800	70.9	1890	74.4	2567	101.1	1264	2781
skd510-060-R	510	DN200	DN100	27.3	4900	192.9	1800	70.9	1890	74.4	2567	101.1	1391	3060
skd720-076-R	720	DN200	DN100	38.5	5382	211.9	2200	86.6	2214	87.2	2587	101.9	1887	4151
skd1110-116-R	1110	DN350	DN150	59.4	5382	211.9	2200	86.6	2214	87.2	2878	113.3	2394	5267
skd1620-116-R	1350	DN350	DN150	68.5	5382	211.9	2200	86.6	2214	87.2	2878	113.3	2450	5390

Performances refer to operation with clean cooler and separator, gas flow rate at 20°C (68°F) / 1 barA. Nominal working conditions: 55% CH₄, 45% CO₂, gas inlet temperature 50°C (104°F) saturated, gas inlet pressure 75 mbar, refrigerant inlet water temperature 1°C (34°F), ambient temperature 35°C (95°F), gas dew point at nominal conditions 8°C (46°F) (from model skd60-007 to model skd265-024) and 4°C (39°F) (from model skd240-030 to model skd1620-116), gas outlet relative humidity below 50%.

*Data refers to skid without filter.

BioEnergy Products

For information relating to Hyperchill BioEnergy water chillers please refer to page 96 of this catalogue.

Hyperfilter BioEnergy

Area of Application

Standard Filter	Biogas, Landfill Gas and Natural Gas
Max. Operating Pressure	0.5 bar g (7.25 psi g)
Operating Temperature	-10°C (14°F) up to 100°C (212°F)

Performance Data

Removal	Pollutants, foams, particulate and separation of residual moisture
Flow Direction	From outside to inside
Particle Removal Size	5 µm / 20 µm
Filtration Efficiency	99.999%
Differential Pressure. Dry	2 mbar

Materials of Construction - Housing

Housing Body	Stainless steel: parts in contact with biogas in AISI304 or AISI316L. not in contact in AISI304
Surface Treatment	Pickling and passivation
Gaskets	Mineral fibers with NBR binder

Materials of Construction - Element

End Caps	Stainless steel
Inner Core	Perforated stainless steel
Filter Medium	260g antistatic polyester spunbonded
Sealing	Epoxy resin
Gaskets	Neoprene
A stainless steel grounding wire is mounted underneath the top ring alongside the filter medium	

Technical Data

Model	Gas Flow*				Connections		Filter Elements
	L/S	m³/min	m³/h	cfm	In	Out	Quantity
FFB105	29	1.8	105	62	DN50	DN80	1
FFB265	74	4.4	265	156	DN80	DN125	1
FFB720	200	12.0	720	424	DN125	DN200	1
FFB1110	308	18.5	1110	653	DN200	DN300	1
FFB3180	695	41.7	2500	1472	DN300	DN450	1

Weights & Dimensions

Model	Dimensions								Weight	
	A		B		C		D		kg	lbs
	mm	ins	mm	ins	mm	ins	mm	ins		
FFB105	440	17.3	1454	57.2	1330	52.4	420	16.5	32	70
FFB265	440	17.3	1424	56.1	1300	51.2	390	15.4	35	77
FFB720	625	24.6	1838	72.4	1595	62.8	545	21.5	99	218
FFB1110	633	24.9	1883	74.1	1650	65.0	600	23.6	108	238
FFB3180	1000	39.4	2208	86.9	1805	71.1	696	27.4	255	561

*Nominal working conditions: gas inlet temperature 40°C (104°F), atmospheric pressure, 60%CH₄, 40%CO₂, pressure drop 3 mbar.

FFB Filters can work at higher gas flow rates with an increase in pressure drop (refer to Parker).

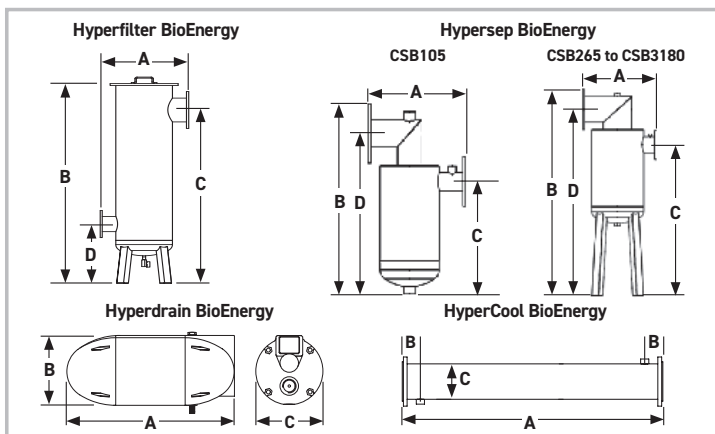

Hypersep BioEnergy

Technical Data / Weights & Dimensions

Model	Gas Flow				Connections		Dimensions								Weight	
	L/s	m ³ /h	m ³ /min	cfm	In	Out	A		B		C		D		kg	lbs
CSB105	29	105	1.8	62	DN80	DN50	365.5	14.4	635.5	25.0	375.8	14.8	535.5	21.1	14	31
CSB265	74	265	4.4	156	DN125	DN80	460	18.1	1425	56.1	1038	40.9	1300	51.2	30	66
CSB720	200	720	12.0	424	DN200	DN125	570	22.4	1765	69.5	1293	50.9	1595	62.8	54	119
CSB1620	450	1620	27.0	954	DN300	DN200	638	25.1	1747.5	68.8	1156	45.5	1525	60.0	88	194
CSB3180	883	3180	53.0	1872	DN450	DN300	833	32.8	2113	83.2	1264	49.8	1805	71.1	153	337

Hypercool BioEnergy

Technical Data / Weights & Dimensions

Model	Gas Flow				Connections		Dimensions						Weight	
	L/s	m ³ /h	m ³ /min	cfm	Gas	Water	A		B		C		kg	lbs
WFB60	17	60	1.0	35	DN80	¾"	1490	58.7	65.5	2.6	89	3.5	16	35
WFB105	29	105	1.8	62	DN80	¾"	1490	58.7	65.5	2.6	89	3.5	19	42
WFB165	46	165	2.8	97	DN125	1"	1490	58.7	100.5	4.0	140	5.5	30	66
WFB265	74	265	4.4	156	DN125	1"	1490	58.7	100.5	4.0	140	5.5	38	84
WFB240	67	240	4.0	141	DN125	1"	1990	78.3	100.5	4.0	140	5.5	48	106
WFB360	100	360	6.0	212	DN200	1¼"	1990	78.3	120.5	4.7	219	8.6	85	187
WFB510	142	510	8.5	300	DN200	1¼"	1990	78.3	120.5	4.7	219	8.6	102	224
WFB720	200	720	12.0	424	DN200	1¼"	1990	78.3	120.5	4.7	219	8.6	124	273
WFB1110	308	1110	18.5	653	DN300	2"	1990	78.3	144.5	5.7	324	12.8	196	431
WFB1620	450	1620	27.0	954	DN300	2"	1990	78.3	144.5	5.7	324	12.8	252	554
WFB2380	661	2380	39.7	1401	DN450	2½"	1990	78.3	179.5	7.1	457	18.0	405	891
WFB3180	883	3180	53.0	1872	DN450	2½"	1990	78.3	179.5	7.1	457	18.0	490	1078

Performances refer to models operating with gas flow rate at FAD 20°C (68°F) / 1 barA.

Nominal working conditions: gas inlet conditions 40°C (104°F) saturated 60%CH₄, 40%CO₂, water inlet temperature 1°C (34°F), gas outlet temperature 8°C (46°F) for models WFB60, WFB105, WFB165, WFB265, 4°C (39°F) for all other models. pressure drop 1.2 kPa with separator.

Hyperdrain BioEnergy

Technical Data / Weights & Dimensions

Model	Materials of Construction			Gas Flow				Conns.		Maximum Pressure		Dimensions						Weight	
	Housing	Float	Lever	L/s	m ³ /h	m ³ /min	cfm	in	out	bar g	psi g	A		B		C		kg	lbs
HDF220BE	Aluminium	Polyamide/st. steel	Polyamide/st. steel	2	6.5	108	4	1"	½"	1	14.5	266	10.5	111	4.4	108	4.3	1.9	4

Replacement Filter Elements and Maintenance Kits For Legacy Parker domnick hunter Products



OIL-X EVOLUTION Elements

Filter Model	Replacement Element
AO005	005AO
AO010	010AO
AO015	015AO
AO020	020AO
AO025	025AO
AO030	030AO
AO035	035AO
AO040	040AO
AO045	045AO
AO050	050AO
AO055	055AO
AO060	060AO requires 3 per filter
AA005	005AA
AA010	010AA
AA015	015AA
AA020	020AA
AA025	025AA
AA030	030AA
AA035	035AA
AA040	040AA
AA045	045AA
AA050	050AA
AA055	055AA
AA060	060AA requires 3 per filter
ACS005	005ACS
ACS010	010ACS
ACS015	015ACS
ACS020	020ACS
ACS025	025ACS
ACS030	030ACS
ACS035	035ACS
ACS040	040ACS
ACS045	045ACS
ACS050	050ACS
ACS055	055ACS
ACS060	060ACS requires 3 per filter

OIL-X EVOLUTION Combination Elements

Filter Model	Replacement Elements
AC010	010AA 010AC
AC015	015AA 015AC
AC020	020AA 020AC
AC025D	025AA 025DAC
AC025E	025AA 025EAC
AC030	030AA 030AC



OIL-Xplus Advantage Elements

Filter Model	Replacement Element
AO-0003G	K003AO
AO-0009G	K009AO
AO-0017G	K017AO
AO-0030G	K030AO
AO-0058G	K058AO
AO-0080G	K145AO
AO-0125G	K145AO
AO-0145G	K145AO
AO-0205G	K220AO
AO-0220G	K220AO
AO-0330G	K330AO
AO-0405G	K430AO
AO-0430G	K430AO
AO-0620G	K620AO
AO-1000G	K330AO requires 3 per filter
AA-0003G	K003AA
AA-0009G	K009AA
AA-0017G	K017AA
AA-0030G	K030AA
AA-0058G	K058AA
AA-0080G	K145AA
AA-0125G	K145AA
AA-0145G	K145AA
AA-0205G	K220AA
AA-0220G	K220AA
AA-0330G	K330AA
AA-0405G	K430AA
AA-0430G	K430AA
AA-0620G	K620AA
AA-1000G	K330AA requires 3 per filter
ACS-0009G	K009ACS
ACS-0017G	K017ACS
ACS-0030G	K030ACS
ACS-0058G	K058ACS
ACS-0080G	K145ACS
ACS-0125G	K145ACS
ACS-0145G	K145ACS
ACS-0205G	K220ACS
ACS-0220G	K220ACS
ACS-0330G	K330ACS
ACS-0405G	K430ACS
ACS-0430G	K430ACS
ACS-0620G	K620ACS
ACS-1000G	K330ACS requires 3 per filter



OIL-X EVOLUTION OVR Maintenance Kits



Model	Maintenance Kit	No. Required
OVR100E	100OVR	1
OVR150H	100OVR	2
OVR200H	100OVR	4
OVR250J	100OVR	6

OIL-Xplus Combination Elements

Filter Model	Replacement Elements
AC-0006G	K009AA K006AC
AC-0013G	K017AA K013AC
AC-0025G	K030AA K025AC
AC-0040G	K058AA K040AC
AC-0065G	K145AA K065AC
AC-0085G	K145AA K085AC



PCO2 MKI Maintenance Kits



SE and ES Oil / Water Separator Maintenance Kits



Product Type	Model	Filter Type	Maintenance Kit
Maxi PCO2	PCO2-1-20 (300)	OIL-Xplus	MAKPCO2-1-20
Maxi PCO2	PCO2-2-20 (300)	OIL-Xplus	MAKPCO2-2-20
Maxi PCO2	PCO2-3-20 (300)	OIL-Xplus	MAKPCO2-3-20
Maxi PCO2	MPlus 4000 20 (300)	OIL-Xplus	MAK-MPLUS4000-20
Maxi PCO2	MPlus 6000 20 (300)	OIL-Xplus	MAK-MPLUS6000-20
Maxi PCO2	MPlus 8000 20 (300)	OIL-Xplus	MAK-MPLUS8000-20
Maxi PCO2	MPlus 10000 20 (300)	OIL-Xplus	MAK-MPLUS10000-20
Mplus PCO2	PCO2-0-20 (300)	OIL-X EVOLUTION	MAKEPCO2-0-20
Mplus PCO2	PCO2-1-20 (300)	OIL-X EVOLUTION	MAKEPCO2-1-20
Mplus PCO2	PCO2-2-20 (300)	OIL-X EVOLUTION	MAKEPCO2-2-20
Mplus PCO2	PCO2-3-20 (300)	OIL-X EVOLUTION	MAKEPCO2-3-20
Mplus PCO2	MPlus 4000 20 (300)	OIL-X EVOLUTION	MAKE-MPLUS4000-20
Mplus PCO2	MPlus 6000 20 (300)	OIL-X EVOLUTION	MAKE-MPLUS6000-20
Mplus PCO2	MPlus 8000 20 (300)	OIL-X EVOLUTION	MAKE-MPLUS8000-20
Mplus PCO2	MPlus 10000 20 (300)	OIL-X EVOLUTION	MAKE-MPLUS10000-20
Maxi PCO2	PCO2-0-24 (350)	OIL-Xplus	MAKPCO2-0-24
Maxi PCO2	PCO2-1-24 (350)	OIL-Xplus	MAKPCO2-1-24
Maxi PCO2	PCO2-2-24 (350)	OIL-Xplus	MAKPCO2-2-24
Maxi PCO2	PCO2-3-24 (350)	OIL-Xplus	MAKPCO2-3-24
Maxi PCO2	MPlus 4000 24 (350)	OIL-Xplus	MAK-MPLUS4000-24
Maxi PCO2	MPlus 6000 24 (350)	OIL-Xplus	MAK-MPLUS6000-24
Maxi PCO2	MPlus 8000 24 (350)	OIL-Xplus	MAK-MPLUS8000-24
Maxi PCO2	MPlus 10000 24 (350)	OIL-Xplus	MAK-MPLUS10000-20

Model	Quantity Required	Part Number
SE2010	1	ESMK1
SE2015	1	ESMK1
SE2030/SE2030P	2	ESMK1
ES36	1	ESMK1
ES90	1	ESMK1
ES125	1	ESMK2
ES250	2	ESMK2
ES500	1	ESMK3
ES1000	2	ESMK3

Replacement Filter Elements For Legacy Parker Zander Products

G Elements

Filter Model	Replacement Element
GH2A	1030A
GH2V	1030ZP
GH2XP	1030XP
G2ZP	1030ZP
G3A	1050A
G3V	1050ZP
G3XP	1050XP
G3ZP	1050ZP
G5A	1070A
G5V	1070ZP
G5XP	1070XP
G5ZP	1070ZP
G7A	1140A
G7V	1140ZP
G7XP	1140XP
G7ZP	1140ZP
G9A	2010A
G9V	2010ZP
G9XP	2010XP
G9ZP	2010ZP
G11A	2020A
G11V	2020ZP
G11XP	2020XP
G11ZP	2020ZP
G12A	2030A
G12V	2030ZP
G12XP	2030XP
G12ZP	2030ZP
G13A	2050A
G13V	2050ZP
G13XP	2050XP
G13ZP	2050ZP
G14A	3050A
G14V	3050ZP
G14XP	3050XP
G14ZP	3050ZP
G17A	5060A
G17V	5060ZP
G17XP	5060XP
G17ZP	5060ZP
G18A	3075A
G18V	3075ZP
G18XP	3075XP
G18ZP	3075ZP
G19A	5075A
G19V	5075ZP
G19XP	5075XP
G19ZP	5075ZP

GL and GL Plus Elements

Filter Model	Replacement Element
GL2A / GL2AP	CP1008A
GL2VL	CP1008ZL
GL2ZL / GL2ZLP	CP1008ZL
GL2XL / GL2XLP	CP1008XL
GL3A / GL3AP	CP2010A
GL3VL	CP2010ZL
GL3ZL / GL3ZLP	CP2010ZL
GL3XL / GL3XLP	CP2010XL
GL7A / GL7AP	CP2020A
GL7VL	CP2020ZL
GL7ZL / GL7ZLP	CP2020ZL
GL7XL / GL7XLP	CP2020XL
GL9A / GL9AP	CP3025A
GL9VL	CP3025ZL
GL9ZL / GL9ZLP	CP3025ZL
GL9XL / GL9XLP	CP3025XL
GL11A / GL11AP	CP3040A
GL11VL	CP3040ZL
GL11ZL / GL11ZLP	CP3040ZL
GL11XL / GL11XLP	CP3040XL
GL12A / GL12AP	CP4040A
GL12VL	CP4040ZL
GL12ZL / GL12ZLP	CP4040ZL
GL12XL / GL12XLP	CP4040XL
GL13A / GL13AP	CP4050A
GL13VL	CP4050VL
GL13ZL / GL13ZLP	CP4050ZL
GL13XL / GL13XLP	CP4050XL
GL14A / GL14AP	CP4065A
GL14VL	CP4065ZL
GL14ZL / GL14ZLP	CP4065ZL
GL14XL / GL14XLP	CP4065XL
GL17A / GL17AP	CP5065A
GL17VL	CP5065ZL
GL17ZL / GL17ZLP	CP5065ZL
GL17XL / GL17XLP	CP5065XL
GL19A / GL19AP	CP5080A
GL19VL	CP5080ZL
GL19ZL / GL19ZLP	CP5080ZL
GL19XL / GL19XLP	CP5080XL



LV Series Paint Compatible

Filter Model	Part Number
G2A/LV	1030A/LV
G2XPH/LV	1030XP/LV
G2ZPH/LV	1030ZP/LV
G3A/LV	1050A/LV
G3XPDH/LV	1050XP/LV
G3ZPDH/LV	1050ZP/LV
G5A/LV	1070A/LV
G5XPDH/LV	1070XP/LV
G5ZPDH/LV	1070ZP/LV
G7A/LV	1140A/LV
G7XPDH/LV	1140XP/LV
G7ZPDH/LV	1140ZP/LV
G9A/LV	2010A/LV
G9XPDH/LV	2010XP/LV
G9ZPDH/LV	2010ZP/LV



Parker Worldwide

Europe, Middle East, Africa

AE – United Arab Emirates,
Dubai
Tel: +971 4 8127100
parker.me@parker.com

AT – Austria, St. Florian
Tel: +43 (0)7224 66201
parker.austria@parker.com

AZ – Azerbaijan, Baku
Tel: +994 50 2233 458
parker.azerbaijan@parker.com

BE/NL/LU – Benelux,
Hendrik Ido Ambacht
Tel: +31 (0)541 585 000
parker.nl@parker.com

BG – Bulgaria, Sofia
Tel: +359 2 980 1344
parker.bulgaria@parker.com

BY – Belarus, Minsk
Tel: +48 (0)22 573 24 00
parker.poland@parker.com

CH – Switzerland, Etoy
Tel: +41 (0)21 821 87 00
parker.switzerland@parker.com

CZ – Czech Republic, Klecany
Tel: +420 284 083 111
parker.czechrepublic@parker.com

DE – Germany, Kaarst
Tel: +49 (0)2131 4016 0
parker.germany@parker.com

DK – Denmark, Ballerup
Tel: +45 43 56 04 00
parker.denmark@parker.com

ES – Spain, Madrid
Tel: +34 902 330 001
parker.spain@parker.com

FI – Finland, Vantaa
Tel: +358 (0)20 753 2500
parker.finland@parker.com

FR – France, Contamine s/Arve
Tel: +33 (0)4 50 25 80 25
parker.france@parker.com

GR – Greece, Piraeus
Tel: +30 210 933 6450
parker.greece@parker.com

HU – Hungary, Budaörs
Tel: +36 23 885 470
parker.hungary@parker.com

IE – Ireland, Dublin
Tel: +353 (0)1 466 6370
parker.ireland@parker.com

IL – Israel
Tel: +39 02 45 19 21
parker.israel@parker.com

IT – Italy, Corsico (MI)
Tel: +39 02 45 19 21
parker.italy@parker.com

KZ – Kazakhstan, Almaty
Tel: +7 7273 561 000
parker.easteurope@parker.com

NO – Norway, Asker
Tel: +47 66 75 34 00
parker.norway@parker.com

PL – Poland, Warsaw
Tel: +48 (0)22 573 24 00
parker.poland@parker.com

PT – Portugal
Tel: +351 22 999 7360
parker.portugal@parker.com

RO – Romania, Bucharest
Tel: +40 21 252 1382
parker.romania@parker.com

RU – Russia, Moscow
Tel: +7 495 645-2156
parker.russia@parker.com

SE – Sweden, Spånga
Tel: +46 (0)8 59 79 50 00
parker.sweden@parker.com

SK – Slovakia, Banská Bystrica
Tel: +421 484 162 252
parker.slovakia@parker.com

SL – Slovenia, Novo Mesto
Tel: +386 7 337 6650
parker.slovenia@parker.com

TR – Turkey, Istanbul
Tel: +90 216 4997081
parker.turkey@parker.com

UA – Ukraine, Kiev
Tel: +48 (0)22 573 24 00
parker.poland@parker.com

UK – United Kingdom, Warwick
Tel: +44 (0)1926 317 878
parker.uk@parker.com

ZA – South Africa, Kempton Park
Tel: +27 (0)11 961 0700
parker.southafrica@parker.com

North America

CA – Canada, Milton, Ontario
Tel: +1 905 693 3000

US – USA, Cleveland
Tel: +1 216 896 3000

Asia Pacific

AU – Australia, Castle Hill
Tel: +61 (0)2-9634 7777

CN – China, Shanghai
Tel: +86 21 2899 5000

HK – Hong Kong
Tel: +852 2428 8008

IN – India, Mumbai
Tel: +91 22 6513 7081-85

JP – Japan, Tokyo
Tel: +81 (0)3 6408 3901

KR – South Korea, Seoul
Tel: +82 2 559 0400

MY – Malaysia, Shah Alam
Tel: +60 3 7849 0800

NZ – New Zealand, Mt Wellington
Tel: +64 9 574 1744

SG – Singapore
Tel: +65 6887 6300

TH – Thailand, Bangkok
Tel: +662 186 7000

TW – Taiwan, Taipei
Tel: +886 2 2298 8987

South America

AR – Argentina, Buenos Aires
Tel: +54 3327 44 4129

BR – Brazil, Sao Jose dos Campos
Tel: +55 800 727 5374

CL – Chile, Santiago
Tel: +56 2 623 1216

MX – Mexico, Toluca
Tel: +52 72 2275 4200



EMEA Product Information Centre

Free phone: 00 800 27 27 5374

(from AT, BE, CH, CZ, DE, DK, EE, ES, FI, FR, IE, IL, IS, IT, LU, MT, NL, NO, PL, PT, RU, SE, SK, UK, ZA)

US Product Information Centre

Toll-free number: 1-800-27 27 537

www.parker.com/gsf