



aerospace
climate control
electromechanical
filtration
fluid & gas handling
hydraulics
pneumatics
process control
sealing & shielding



P70

Mobile Directional Control Valve

Proportional, Open or Closed Centre



ENGINEERING YOUR SUCCESS.

Catalogue layout

This catalogue is designed to give an overview of the P70 directional valve and to show how it can be customised to meet your needs exactly. Apart from general information and basic technical data therefore, the catalogue contains descriptions of the variety of options available for the different function areas of the valve. After you have studied the options and made your selection, we will tailor your valve to meet your operating and control criteria.

Each function area is given as a subheading, followed by a brief description. When several optional functions are available for the same function area, the subheading is followed by an "Item number" in square brackets, e.g. **Main pressure relief valve [16]**. This is followed by a series of coded options, e.g. **PS, PB, Y**, together with a brief description of what each code represents. Alternatively, one or more pressure, flow or voltage options are given.

On pages 12 and 13 there are general circuit diagrams showing the basic functions of the P70 valve, together with the item numbers and letter codes used to represent them. Naturally, the same item numbers and letter codes are used in all sub-circuit diagrams that appear elsewhere in the catalogue in conjunction with descriptions of the respective function areas. All sub-circuit diagrams have been extracted from the general circuit diagram. Please note that, unless otherwise stated, all sections and views of the valves have been drawn as seen from the inlet section.

How to order your valve

Parker has developed a computer program to specify the P70, so that the configuration of your valve can be optimised to give maximum performance in your particular hydraulic system.

Based on the demands on each individual machine function, the computer specifies the configuration of the valve to give optimal performance. It also generates complete documentation for your valve in the form of a detailed specification and hydraulic circuit diagram.

The program also generates a unique product designation that is subsequently stamped into the data plate on your valve. Your

customised valve specifications remain on our database to facilitate rapid identification of your valve in the event of re-ordering or servicing.

Early consultation with Parker saves time and money

Our experienced application engineers have in-depth knowledge of the different types of hydraulic system and the ways in which they work. They are at your disposal to offer qualified advice on the various combinations of functions and control characteristics you may require, and to advise how to obtain the best possible economy.

By consulting Parker early in the project planning stage, you are assured of a comprehensive hydraulic system that will give your machine the best possible operating and control characteristics, together with outstanding economy.

Conversion factors

1 kg	= 2.2046 lb
1 N	= 0.22481 lbf
1 bar	= 14.504 psi
1 l	= 0.21997 UK gallon
1 l	= 0.26417 US gallon
1 cm ³	= 0.061024 in ³
1 m	= 3.2808 feet
1 mm	= 0.03937 in
9/5 °C + 32	= °F

Subject to alteration without prior notice. The graphs and diagrams in this catalogue are typical examples only. While the contents of the catalogue are updated continually, the validity of the information given should always be confirmed. For more detailed information, please contact Parker Hannifin.



WARNING – USER RESPONSIBILITY

FAILURE OR IMPROPER SELECTION OR IMPROPER USE OF THE PRODUCTS DESCRIBED HEREIN OR RELATED ITEMS CAN CAUSE DEATH, PERSONAL INJURY AND PROPERTY DAMAGE.

This document and other information from Parker-Hannifin Corporation, its subsidiaries and authorized distributors provide product or system options for further investigation by users having technical expertise.

The user, through its own analysis and testing, is solely responsible for making the final selection of the system and components and assuring that all performance, endurance, maintenance, safety and warning requirements of the application are met. The user must analyze all aspects of the application, follow applicable industry standards, and follow the information concerning the product in the current product catalog and in any other materials provided from Parker or its subsidiaries or authorized distributors.

To the extent that Parker or its subsidiaries or authorized distributors provide component or system options based upon data or specifications provided by the user, the user is responsible for determining that such data and specifications are suitable and sufficient for all applications and reasonably foreseeable uses of the components or systems.

Offer of Sale

Please contact your Parker representation for a detailed "Offer of Sale".



List of contents	Page
General Information.....	4
(Valve with open centre, P70CF), (Valve with open centre, P70CF)	5
Control characteristics.....	5
Constant-pressure systems, CP, CPU, CPU, (Valve with closed centre, P70CP)	6
Control characteristics.....	6
Load sensing systems, LS, (Valve with load sensing, P70LS)	7
Operating characteristics.....	7
System connection	8
A. Power beyond connection, multi-valve system, P70CF only	8
B. Power beyond connection, single-valve system, P70CF only	8
C. Parallel connection, multi-valve system.....	9
Technical Data	10
Environmental characteristics.....	11
Hydraulic circuit diagram showing basic functions, standard valve	12
Hydraulic circuit diagram showing basic functions (actuators with closed spool end) ..	13
Inlet Section.....	14
Type of inlet section [15].....	14
Main pressure relief valve [16].....	17
Pressure setting [17].....	17
Pump unloading [22].....	17
External pump unloading or multi-level main pressure relief function	18
Tank connection T2 [25].....	18
Pump connection P1 [26]	18
Pump connection P2 [27]	18
Mid-inlet section [90].....	19
Options, mid-inlet [93].....	20
Main pressure relief valve [94].....	20
Pressure setting [98].....	20
End Section	21
Type of end section [30].....	21
Tank connection T1 [33].....	21
Tank connection T3 [34].....	21
Series-connection function [36]	21
Reducing valve [37]	22
Pilot-oil strainer [39].....	22
Separate tank connection for pilot circuit [40].....	22
Spool Sections.....	23
Type of spool section [47]	23
Lever bracket [51]	24
Spool actuators [50].....	25
Hand-operated spool actuators with open spool end	25
Remote controlled ON/OFF spool actuators with open spool end	25
Remote controlled proportional spool actuators with closed spool end	26-28
Solenoid variant [59].....	27
Connector Type [56].....	27-28
Spool position indicator [52]	29
Spool function [60].....	30
Spool designation [69].....	30
Pressure gallery [66]	30
Choice of Spool	30
Pressure limiters in work ports [76A/B](Port relief valves).....	31
Port relief valve [76].....	31
Function blocks (manifolds)	32
Connectors, electrical	32
Hand levers for open and closed spool-actuators	33
Dimensional drawings, standard valve	34
Dimensional drawings, model with closed spool end	35
Dimensional drawings, spool actuators	36-38

[00] refers to item numbers in customer specification.



The P70 directional valve is of modular construction. It is designed for many different applications and used extensively in machines such as lorry cranes, mini-excavators, small wheeled loaders and concrete placing cranes. The P70 is available in three different versions: the **P70CF** with an open centre for fixed pumps, the **P70CP** with a closed centre for variable displacement pumps and the **P70LS** with a closed centre, coupled with a load sensing signal, to the variable displacement pump.

Compact system construction

The P70 offers unique possibilities for the integration of application-adapted functions to give compact and total system solutions for a wide range of mobile machines.

Freedom in machine design

In order to give the system designer a greater level of flexibility and freedom, the valve is designed to be either directly operated, or controlled by electric, pneumatic or hydraulic remote controls. A combination of these direct, and remote controls, can be utilised allowing a greater degree of component location and pilot media options.

Economy

Thanks to its modular construction, the P70 can be optimised for both simple and complex functions. The possibility of integrating total function solutions gives low overall system costs. The valve can be modified or expanded as necessary to suit the needs of the customer.

Safety

The valve is of robust construction, with each function unitised. This facilitates both training and servicing and contributes greatly to safety. Moreover, the valve can be fitted with a special inlet section that enables an emergency STOP function to be incorporated into the valve to meet the demands of the EC Machinery Directive in a uniquely simple way.

Design

The P70 is a stackable valve system and can be supplied in combinations of 1 to 10 spool sections, additionally manifold sections can also be utilised to add further system flexibility. The valve is designed for system pressures of up to 320 bar.

The maximum recommended flow rates for the P70CF, CP and LS are 70, 90 and 90 l/min respectively, depending on how the valve is equipped. There are also a wide range of different available spools, enabling specific control characteristics to be optimised.

Benefits

- Low fuel consumption and heat generation with low pressure drops.
- Productivity - our complete application adapted spool range will optimise each machine function to provide unsurpassed driver control and productivity.
- Precision - excellent repeatability especially during simultaneous operation by having machined land edges in the valve housing.

- Long service life – e.g. open spool ends with rubber bellows increase the service life of both spools and spool seals. Quality materials and high manufacturing precision ensure a superior product
- Smooth machine feel with less driver fatigue with low lever forces.
- Integrated functions – by combining P70 and flanged on manifolds additional functionality is effectively provided in the minimum space envelope and at the same time with reduced hosing complexity and cost.
- Flexibility – options allow for connection of more than one pump or valve in a system to increase the range of applications P70 can be used on.
- Security - P70 prevents undesirable load sinking during simultaneous operation with separate check valves positioned in each spool section.
- Safety - P70 gives an individual maximum pressure limitation with separate port relief valves positioned in each work port.
- Minimized downtime with simple design, which makes P70 easy to service. An emphasis on simplicity of design makes the P70 the best in class.

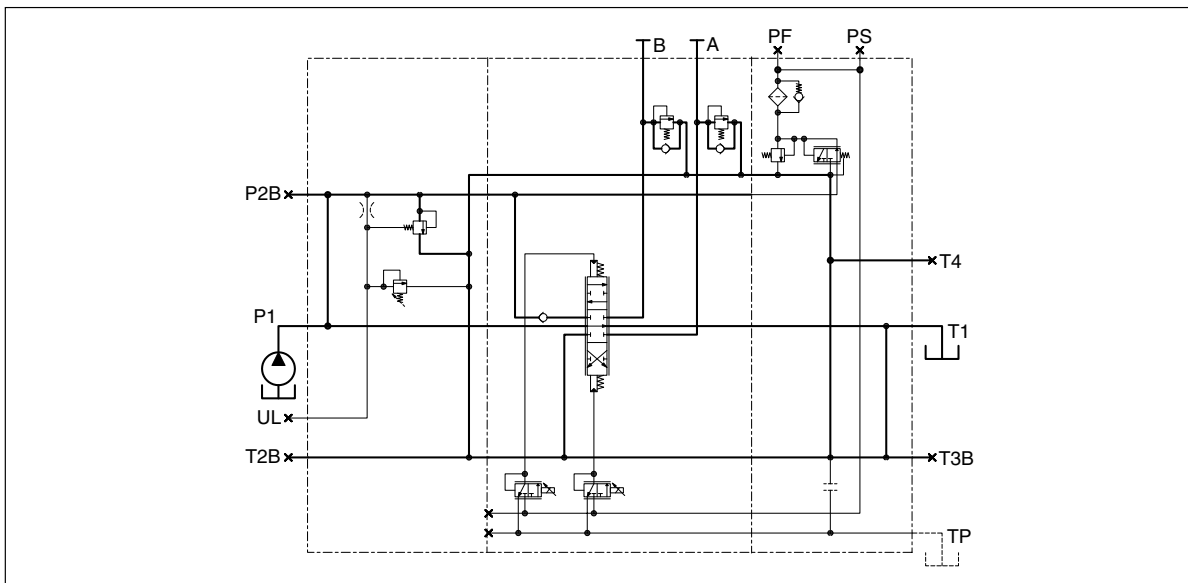

Principle circuit diagram for valve with open centre

**Open centre systems, OC
(Valve with open centre, P70CF)**

The pump in a constant-flow system has fixed displacement, which means that the flow remains constant for a given engine speed. The pressure, however, changes to meet demand.

Any oil that is not directed out to a consumer flows back to tank via the free-flow gallery (open centre) in the valve. When several lifting functions are activated simultaneously, the pressure is determined by the heaviest load. Simultaneously operated functions should therefore have roughly the same pressure needs, or be divided into separate pump circuits to minimise cross-functional interference and give good operating economy. Provided that most of the pump capacity is used, the OC system is very economical. For this reason, it is important for the system to have a pump of the right capacity.

Control characteristics

In hand-operated valves, there is no clear-cut relationship between the stroke of the lever and the speed of the load. The speed of the load will depend on the following four variables: its weight, the pump flow, the direction of force and the direction of movement of any other simultaneously operated loads. The reason for this is that, when more passages are opened subsequently, the flows redistribute themselves so that the pressure drop in all flow paths becomes equal.

The P70CF's customised valve spools give considerably better simultaneous-operating characteristics. In some cases, this can result in higher energy losses during the fine-metering stage.

Our directional valves, which are designed to be remote controlled, are usually fitted with pressure compensated spools. This means that the regulated flow remains constant for a given lever stroke, regardless of any pressure variations within the system.

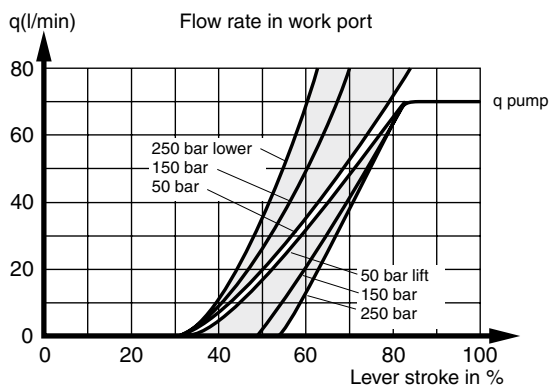

In P70CF valves with hand-operated spools, speed is affected by the weight of the load, i.e. the heavier the lift load, the longer the lever stroke needed before the load starts to move. Conversely, the heavier the load to be lowered, the faster the lowering sequence.

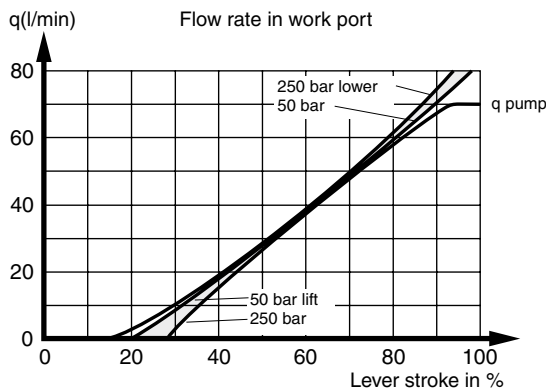

In the P70CF equipped with FPC, PC, ECS and ECH closed spool-actuators, the spools are pressure compensated, with the result that the load's influence on speed is negligible.



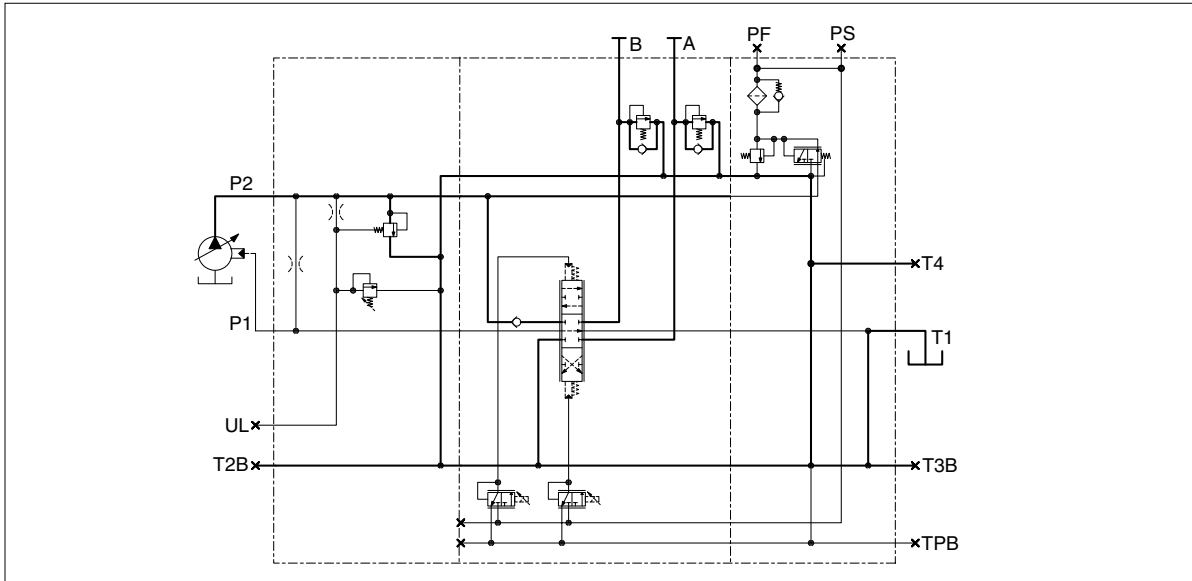

Principle circuit diagram for valve with closed centre

**Constant-pressure systems, CP, CPU
(Valve with closed centre, P70CP)**

Constant pressure systems are supplied by a variable displacement pump. This type of pump is controlled by a regulator which ensures that the pressure is kept constant whilst the flow varies to suit the demand. The constant-pressure system is of relatively simple construction, with an uncomplicated valve. However, the variable pump is more advanced than pumps with fixed displacement.

To maintain the constant-pressure system's superior control characteristics, the pump must be dimensioned to give the sum of the maximum flows for simultaneously operated functions. If the pressure cannot be maintained, the valve loses its control characteristics quickly and the actuated functions start to influence each other, with the lightest loads receiving the most oil. However, this system is less susceptible to pressure drops, as the pressure corresponding to the machine capacity is always available.

There are two main types of pump on the market. What distinguishes them from each other is where the signal that influences the pump regulator comes from. One pump type takes the signal internally, whereas the other requires a signal from the directional valve. The P70CP can be used equally efficiently with either type.

Control characteristics

A correctly specified P70CP gives excellent control characteristics, with different functions having no affect upon each other. The system also has great anti cavitation characteristics which allow a lowering movement to change to a lifting one without delay. The maximum speed of each P70CP function is determined by the design of the spool and the pressure demands of the load. The P70CP can be fitted with a range of Parker's specifically designed spools, allowing them to be exactly suited to the customers speed and function requirements. In the P70CP too, remote controlled spools are pressure compensated. However, if the flow requirements of the system exceed the maximum capacity of the pump, the pressure level cannot be maintained and the normally very good control characteristics deteriorate.

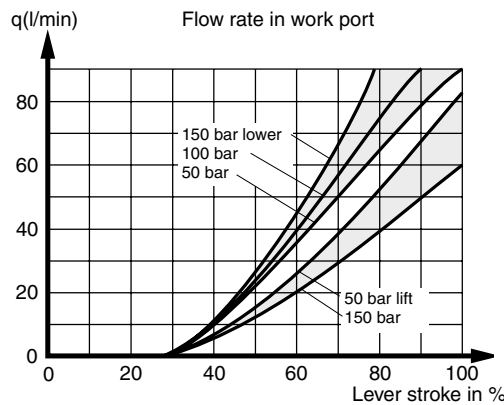

In the P70CP with hand-operated spools, all loads start moving at the same point, regardless of the size and direction of the load. The size of the load does, however, affect the slope of the curve to some extent.

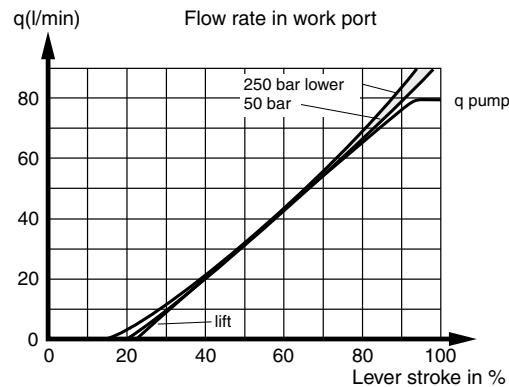

In the P70CP equipped with FPC, PC, ECS and ECH closed spool-actuators, the spools are pressure compensated, with the result that the load's influence on speed is negligible.



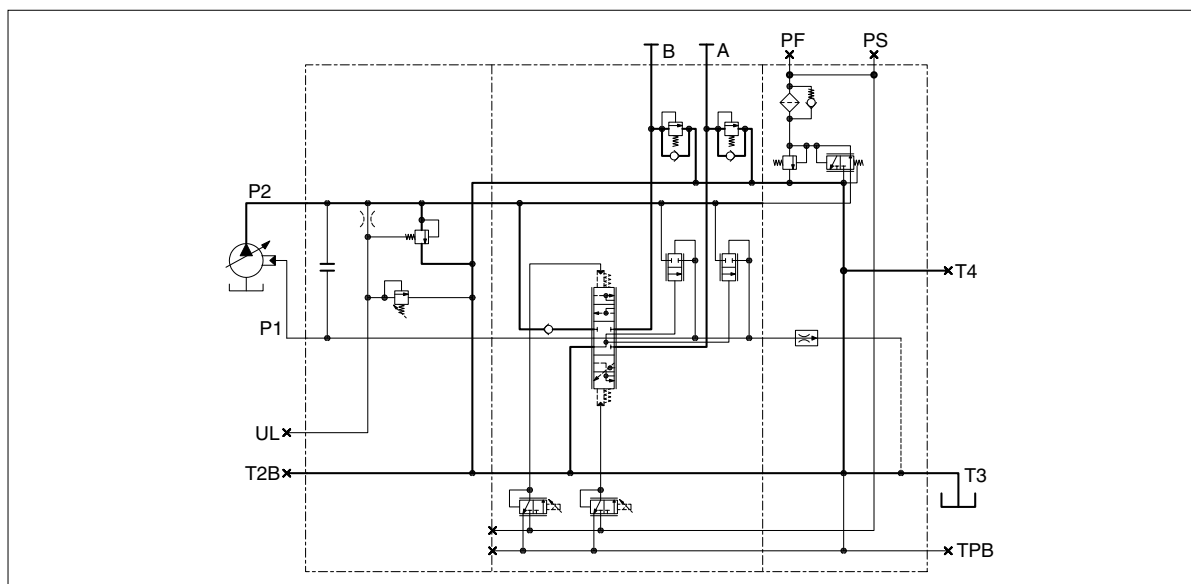

Principle circuit diagram for valve with load sensing

Load sensing systems, LS (Valve with load sensing, P70LS)

In the load sensing system both pressure and flow are modulated to match immediate needs from the consumers, with a pressure level corresponding to the heaviest load at that moment.

When supplied from a variable displacement pump the directional control valve sends a load signal to the pump control regulator, which adjusts the pump output to maintain a constant pressure difference between the pump output and the load signal.

In the P70LS, the free flow gallery is used to collect the load pressures from all the motor ports of the valve. The signal of the highest load is then delivered to the variable pump regulator.

In order to achieve good operating characteristics, the pump should be sized to deliver flow equal to the sum of all simultaneously working functions. If the control pressure difference cannot be maintained, the operating characteristics of the valve can quickly deteriorate, and the controlled functions will influence each other, progressively resulting in lower loads receiving more flow than the higher ones.

In common with a constant flow system, simultaneously working functions should have approximately the same pressure requirement or they should be divided into separate circuits for high operating efficiency.

Operating characteristics

With a correctly adjusted P70LS valve, the operating characteristics of the system are very good. The constant differential pressure maintained by the pump means that the flow to the heaviest load in a load sensing system is always pressure compensated.

However, load sensing does not mean that other functions are pressure compensated. To achieve good operating characteristics, the spools should be adapted for each function.

P70LS valves are designed for remote control and have pressure-compensated spools. This means that the regulated flow remains constant at a certain lever position, regardless of pressure variations in the system.

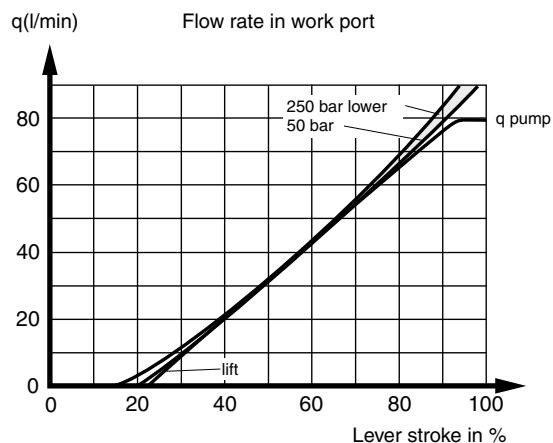

In the P70LS equipped with PC, ECS and ECH closed spool-actuators, the spools are pressure compensated, with the result that the load's influence on speed is negligible.

Below are a few examples of how the P70 can be connected up.

A. Power beyond connection, multi-valve system, P70CF only

The pump is connected to the first valve. Flow that is not directed to a consumer via the first valve continues to the next valve. The first valve therefore has priority, i.e. in the event of full spool actuation in the first valve, no flow continues to the next valve.

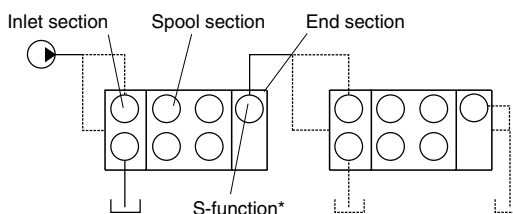

If an additional pump is connected to valve 2, then valve 2 receives the flow from pump 2 plus any residual flow from valve 1.

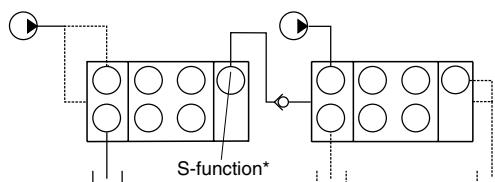

B. Power beyond connection, single-valve system, P70CF only

The pump is connected to the inlet section. Flow that is not directed out to consumers connected before the mid-inlet section continues to consumers connected after the mid-inlet section. This means that the first spool sections have priority, i.e. in the event of full spool actuation in a section before the mid-inlet section, no flow continues to the sections after the mid-inlet section.

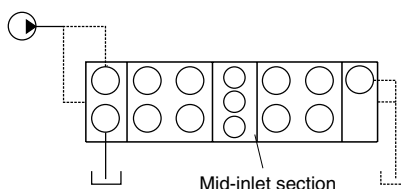

If an additional pump is connected to the mid-inlet section, then subsequent sections will receive the flow from pump 2 plus any flow from pump 1 that has not been used by the sections before the mid-inlet section.

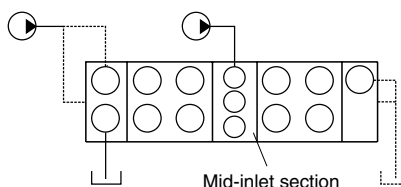

----- = Alternative connection

--- --- = Signal line

* The different functions are described in more detail on pages 14 - 21.

C. Parallel connection, multi-valve system

In parallel connection, the same pump is connected to two or more valves. The function is the same as if the pump were connected to a single large valve.

Parallel connection, fixed pump (OC), P70CF

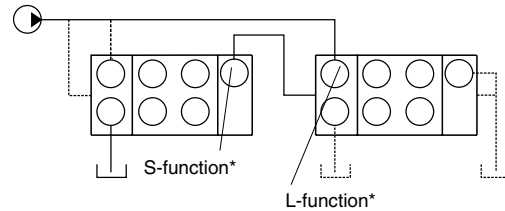

Parallel connection, variable pump (CP), P70CP

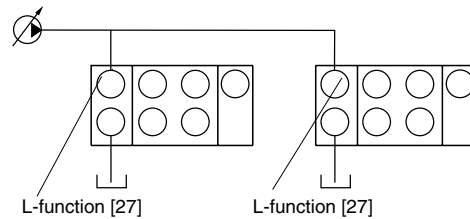

Parallel connection, variable pump (CPU, LS), P70CP, P70LS

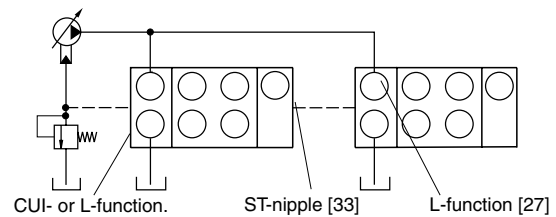

----- = Alternative connection

----- = Signal line

* The different functions are described in more detail on pages 14 -21.

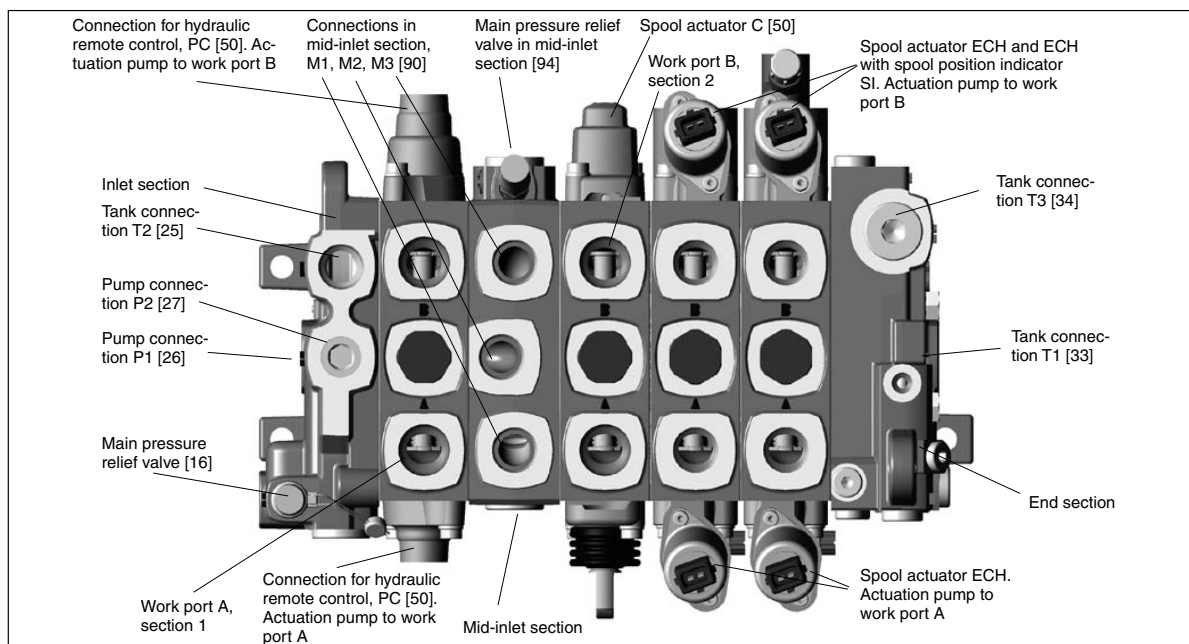
Pressures

Pump connection	max. 320 bar* (4640 psi)
Work ports	max. 350 bar* (5075 psi)
Tank connection, static	max. 20 bar (290 psi)

Flow rates (recommended)

P70CF. Pump connection	max. 70 l/min (18.5 USgpm)**
P70CP. Pump connection	max. 90 l/min (23.8 USgpm)**
P70LS. Pump connection	max. 90 l/min (23.8 USgpm)**
P70CF. Return fr. work port	max. 100 l/min (26.5 USgpm)**
P70CP. Return fr. work port	max. 125 l/min (33.0 USgpm)**
P70LS. Return fr. work port	max. 125 l/min (33.0 USgpm)**

Internal pilot pressure

Fixed setting	35 bar (508 psi)
---------------	------------------

Leakage from work port over spool

From A or B port: max. 75 cm³/min (4.58 cu.in/min) at 250 bar (3625 psi), oil temperature 50 °C (122 °F) and viscosity 30 mm²/s (cSt).

Weight

Since the weight will vary somewhat depending on the configuration of the valve, the values below are approximate.

Valve housing inclusive of spool, pressure relief valve etc. and inclusive of spool actuator.

Standard inlet section	2.7 kg (6.0 lb)
Inlet with bypass	4.9 kg (10.8 lb)
Single spool section C	3.5 kg (7.7 lb)
Double spool section C	7.2 kg (15.9 lb)
Single spool section ECH	4.1 kg (9.0 lb)
Double spool section ECH	8.4 kg (18.5 lb)
Mid-inlet section	2.7 kg (6.0 lb)
End section with pilot pressure supply	3.8 kg (8.4 lb)
End section	2.7 kg (6.0 lb)

Connections

Unless stated otherwise, all standard connections are available in two versions: G-version (BSP pipe thread) for flat seal (type Tredo) as per ISO 228/1 and UNF-version for O-ring seal as per ISO 11926-1.

Connection	Location	G-version	UNF-version
P1, P2	Inlet section	G1/2	7/8-14 UNF-2B
PX	Inlet section, IU	G1/4	9/16-18 UNF-2B
T2	Inlet section, I	G1/2	7/8-14 UNF-2B
T2	Inlet section, IU	G3/4	1-1/16-12 UN-2B
UL	Inlet section	G1/4	9/16-18 UNF-2B
P, EF	Inlet section, PRI	G3/4	—
X	Inlet section, PRI	G1/4	—
M1, M2, M3	Mid-inlet	G1/2	7/8-14 UNF-2B
Work ports			
A and B	Spool section	G1/2	7/8-14 UNF-2B
PC	Spool section	G1/4	9/16-18 UNF-2B
T1, T3	End section	G1/2	7/8-14 UNF-2B
T4	End section	G1/4	9/16-18 UNF-2B
TP	End section	G1/4	9/16-18 UNF-2B
PS	End section	G1/4	9/16-18 UNF-2B
PF	End section	G1/4	9/16-18 UNF-2B male connector

Surface treatment (painted) [07]

The paint is only a primer. For full corrosion protection, the valve must be painted with an outer coat.

X	Unpainted
P	Primed valve, black. Primer only

* Stated pressures are maximum absolute shock pressures at 10-bar tank pressure. See page 16.

** Max. recommended flow rate dependent on choice of spool.

The valve can be mounted in all conceivable directions. However, the mounting base should be flat and stable so that the valve is not subjected to strain.

While the O-rings in the valve are normally of nitrile rubber, there are a number of special Viton variants. (Please contact Parker for further information.) Moreover, it is suggested that the P70CP is selected with the variant A002, which means that the O-rings between the parting surfaces will be manufactured from Viton. This variant is suggested as Viton withstands heat more comprehensively than nitrile rubber, and a constant pressure system working at near capacity will generate more heat than an open centre system.

Temperature

Oil temperature, working range +20 °C to 90 °C (68 to 194 °F)*

Filtration

Filtration must be arranged so that Target Contamination Class 20/18/14 according to ISO 4406 is not exceeded. For the pilot circuit, Target Contamination Class 18/16/13 according to ISO 4406 must not be exceeded.

Hydraulic fluids

The best system performance is obtained using mineral-base oil of high quality and cleanness in the hydraulic system. Hydraulic fluids of type HLP (DIN 51524), oil for automatic gear-boxes Type A and engine oil type API CD can be used.

Viscosity, working range 15-380 mm²/s**

Technical information in this catalogue is applicable at an oil viscosity of 30 mm²/s and temperature of 50 °C (122 °F) using nitrile rubber seals.

* Product operating limits are broadly within the above range, but satisfactory operation within the specification may not be accomplished. Leakage and response will be affected when used at temperature extremes and it is up to the user to determine acceptability at these levels.

** Performance efficiency will be reduced if outside the ideal values. These extreme conditions must be evaluated by the user to establish suitability of the products performance.

Pressure drops

Pressure drop with the pump-unloading inlet

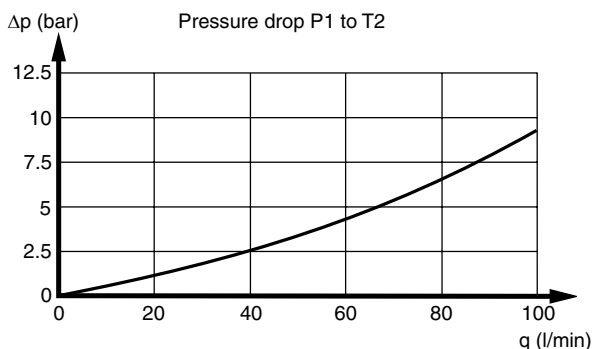

Pump unloading function. See description and hydraulic circuit diagram on page 16.

Valve with standard inlet section and end section

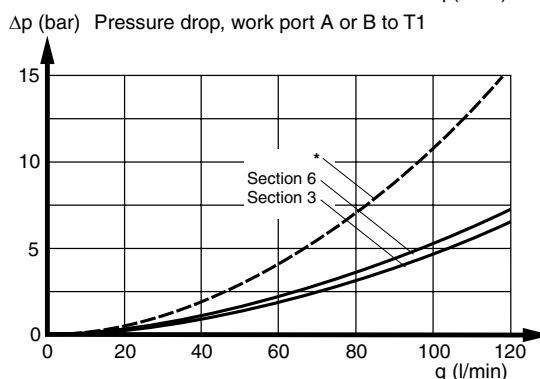
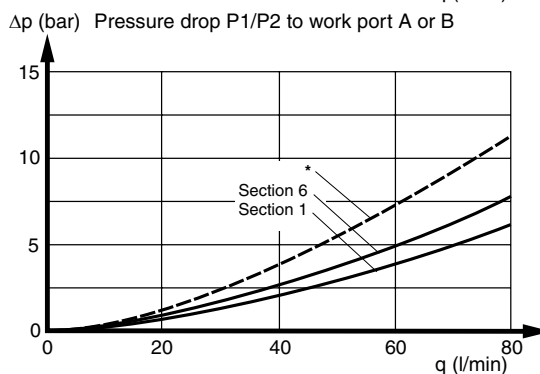
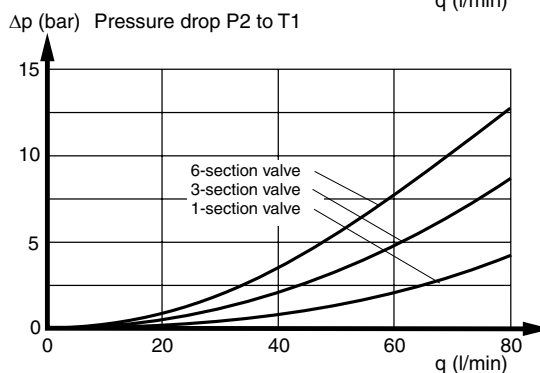
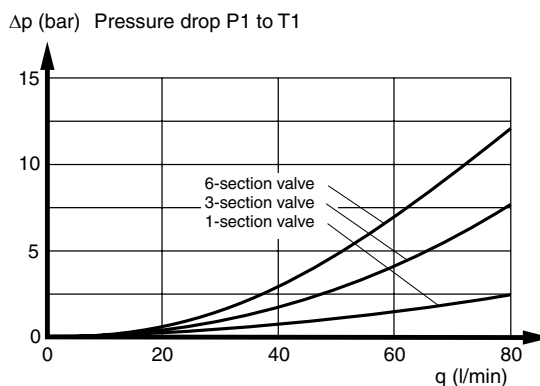

* Broken line illustrates example of pressure drop in P70CF over a D-spool for q=65 l/min in section 6.



Hydraulic circuit diagram showing basic functions, standard valve

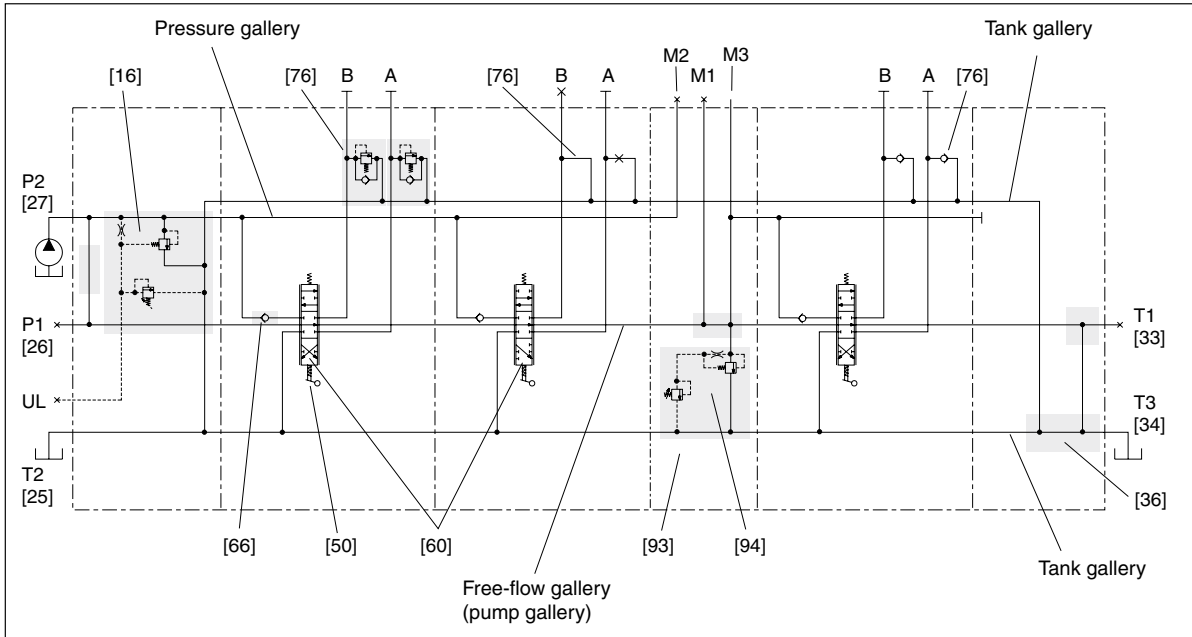

The circuit diagram above shows the P70CF with three spool sections and a mid-inlet between sections 2 and 3.

The shaded areas indicate functions or function groups that are described further on in the catalogue.

The item numbers in the hydraulic circuit diagram above and table below refer to function areas for which different options are available. The valve above is equipped as described below.

For details of other options available, for the P70CP and P70LS, please refer to the respective function areas [item numbers] given alongside the various sub-headings that begin on page 13.

Item No.	Code	Description
16	PS	Adjustable main pressure relief valve in inlet.
25	T2	Tank connection in inlet open.
26	P1B	Pump connection P1 in inlet plugged.
27	P2	Pump connection P2 in inlet open.
33	T1B	Tank connection T1 in end section plugged.
34	T3	Tank connection T3 in end section open.
36	/	Free-flow gallery connected with tank.
50	C	Spring-centred spool actuator on all sections for stepless operation by hand.
60	D	Spool for double-acting function in sections 1 and 3.
	EA	Spool for single-acting function working on work port A. Work port B blocked in section 2.

Item No.	Code	Description
66	N	Load-hold check valve in each section to prevent undesirable load sinking.
76	PA	Combined port-relief and anti-cavitation valve in work ports A and B of sections 1.
	Y2	Connection between service-port A and tank gallery blocked in section 2.
	X2	Connection between service-port B and tank gallery open in section 2 (always the case with EA spool).
	N2	Anti-cavitation valves fitted in work ports A and B of section 3.
93	C3	Mid-inlet with power beyond connection to give priority to preceding sections. Intended for single or multi-pump operation.
94	PS	Adjustable main pressure relief valve in mid-inlet.

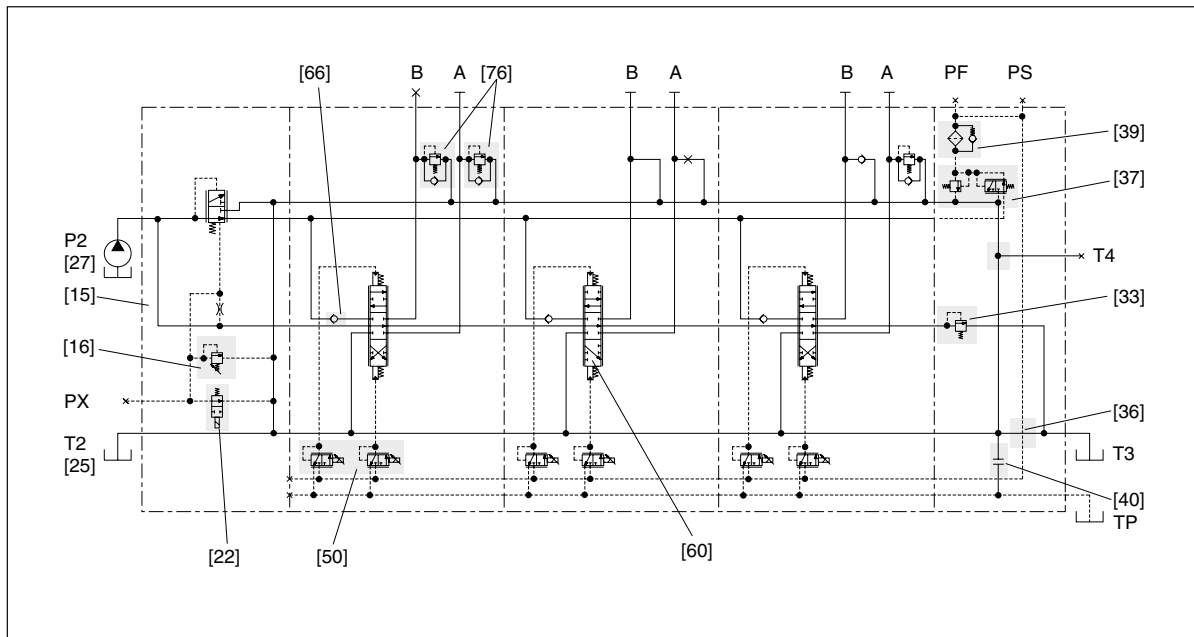
Hydraulic circuit diagram showing basic functions (actuators with closed spool end)

The circuit diagram above shows the P70 with three electro-hydraulically controlled spool sections and an integrated pilot-oil

supply. The shaded areas indicate functions or function groups that are described further on in the catalogue.

The item numbers in the hydraulic circuit diagram above and table below refer to function areas for which different options are available. The valve above is equipped as described below.

For details of other options available, for the P70CP and P70LS, please refer to the respective function areas [item numbers] given alongside the various sub-headings that begin overleaf.

Item No.	Code	Description	Item No.	Code	Description
15	IU	Inlet with integrated bypass and pump-unloading function	60	D	Spool for double-acting function in sections 1 and 3.
16	PS	Adjustable main pressure relief valve in inlet.	EA		Spool for single-acting function working on work port A. Work port B blocked in section 2.
22	BEN	Electric pump-unloading function.	66	N	Load-hold check valve in each section to prevent undesirable load sinking.
25	T2	Tank connection in inlet open.	76	PA	Combined port-relief and anti-cavitation valve in work ports A and B of section 1 and work port A of section 3.
27	P2	Pump connection P2 in inlet open.	Y2		Connection between service-port A and tank gallery blocked in section 2.
33	PT	Counter pressure function.	X2		Connection between service-port B and tank gallery open in section 2 (always the case with EA spool).
36	/	Free-flow gallery connected with tank.	N2		Anti-cavitation valve fitted in work port B of section 3.
37	R35	Reducing valve for pilot-oil supply.			
39	S	Internal pilot-oil filter.			
40	TP	Separate tank connection for pilot oil.			
50	ECS	Spool actuator for electric remote control.			

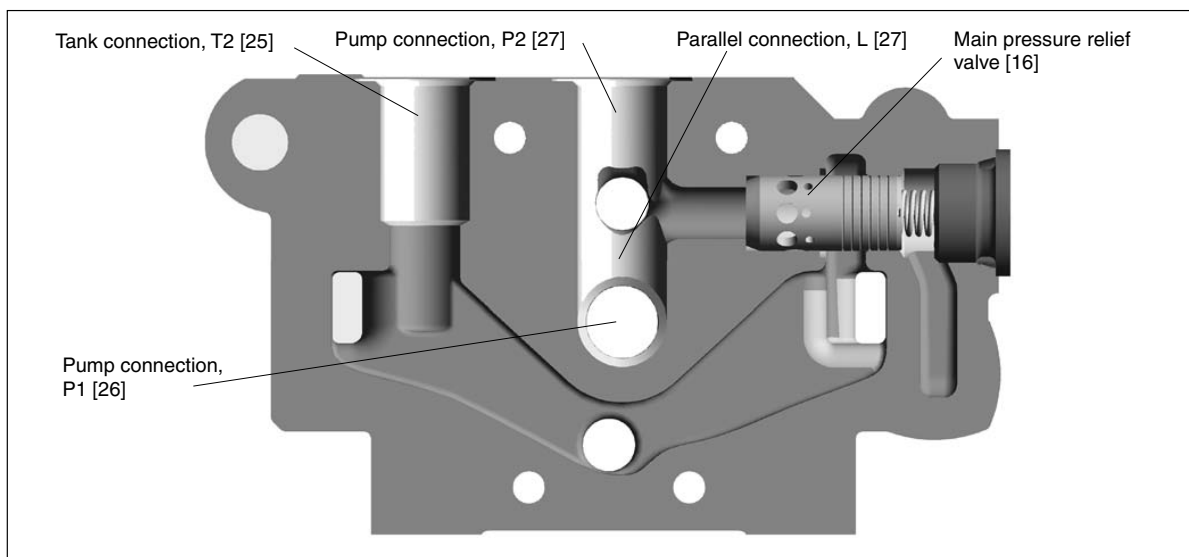
Standard inlet section

The inlet section comes in three versions: the standard version, version with pump unloading and version with priority function.

The standard inlet section has two pump connections, P1 and P2, and a tank connection T2. The inlet section also contains the pilot-operated main pressure relief valve, in which either the UL connection for external pump unloading or the multi-level pressure relief function are located (see page 17).

The P70 with closed centre (P70CP) is created by combining inlet I with L or CUI at item [27]. P70LS shall always use the L option at item [27]. The difference between the P70CP and P70CF is that, in the P70CP, the open centre is used to break a hydraulic signal rather than to convey unused pump flow to tank. P70LS is using the open centre gallery for the load signal from the work port to the variable pump.

Type of inlet section [15]

- I** Standard inlet.
(P70CF, P70CP, P70LS)
- IU** Inlet with integrated pump-unloading function
(P70CF only).
- PRI** Inlet with integrated priority function
(P70CF, P70CP, P70LS)

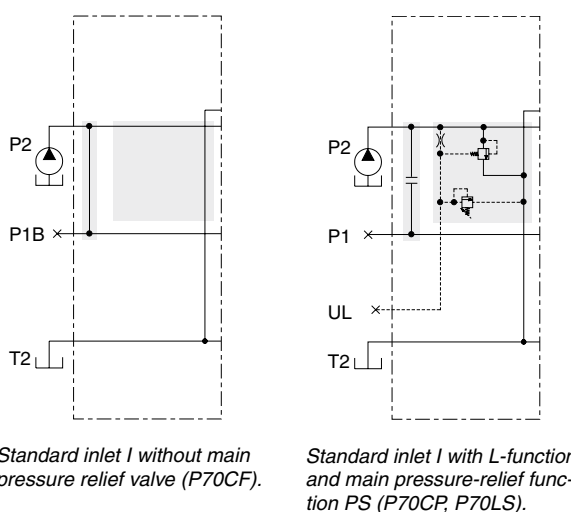

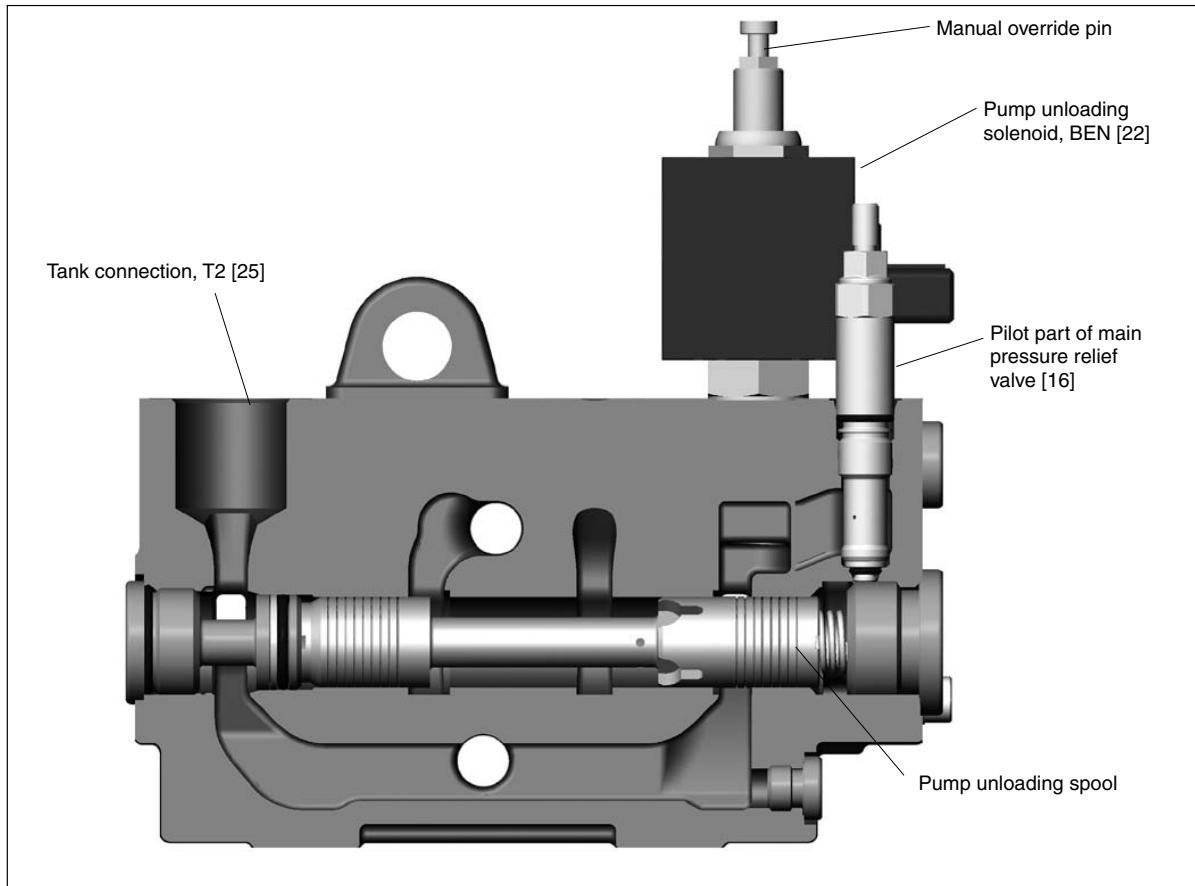

Inlet section for valve with integrated pump unloading function.

The inlet section, IU, includes a pump unloading function. This, together with some form of overcentre valve, enables the machine manufacturer to equip the machine with an emergency STOP function.

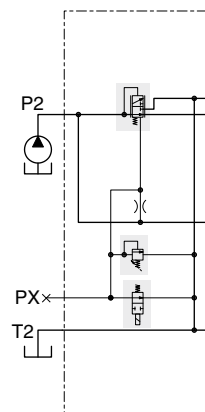

Inlet section with pump unloading and pilot-operated main pressure relief valve.

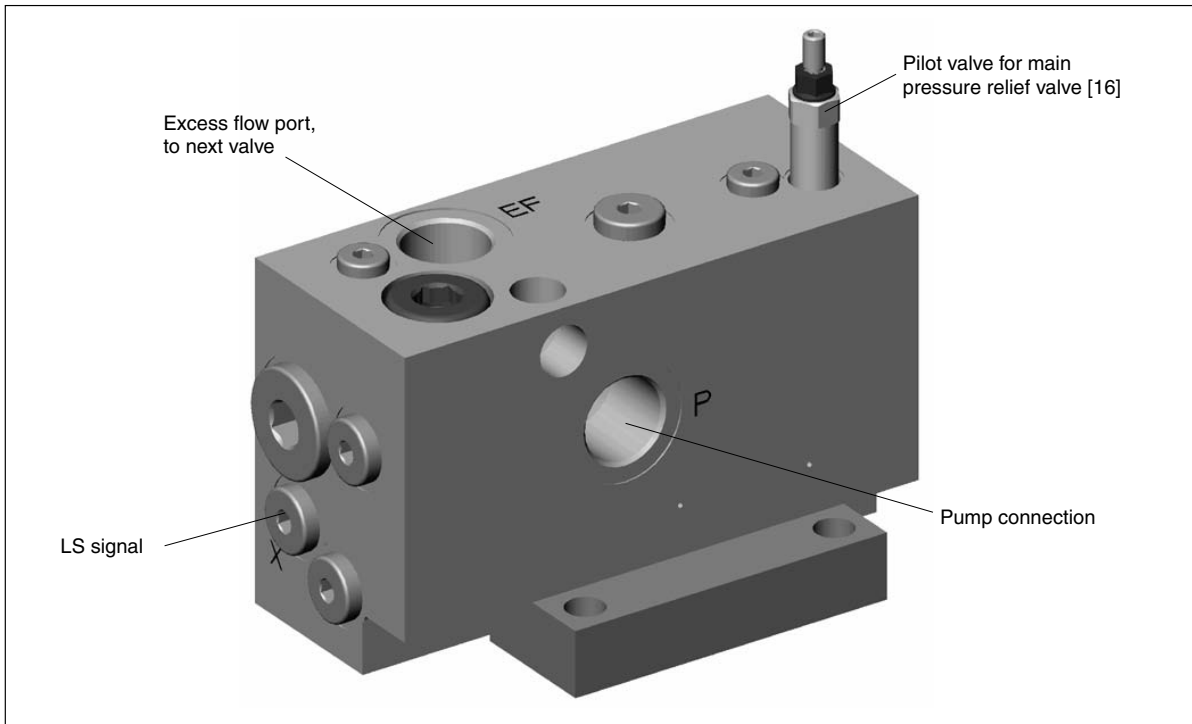

Inlet section for a valve with priority function

The inlet section PRI includes a priority function. The PRI inlet gives priority of the complete valve, and it will be prioritized before a valve connected to port EF. Both fixed and variable pump can be used in the system, and the valve connected via port EF can be either a load sense valve or a constant flow valve. In a load sense system the load sense signal is received from port X. Port X is by default plugged.

The PRI inlet is ideal for support leg functions.

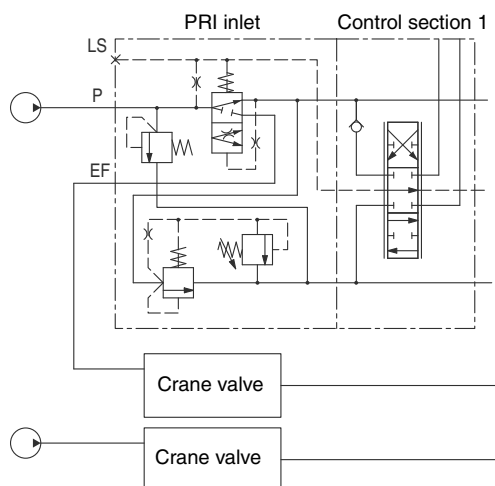

Inlet PRI in a system with fixed pump

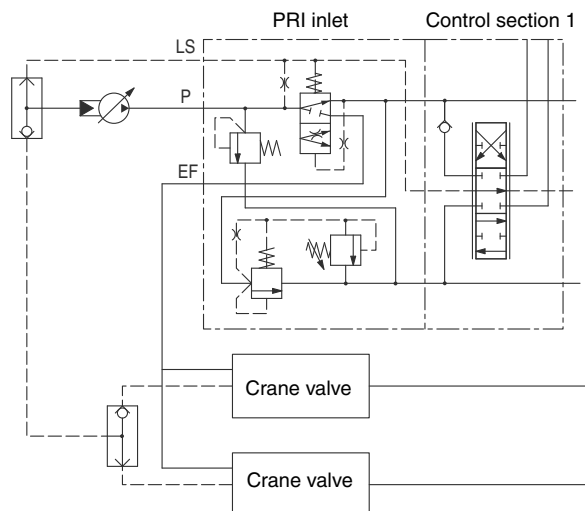

Inlet PRI in a system with variable pump

Main pressure relief valve [16]

The inlet section is equipped with an adjustable, pilot-operated pressure relief valve.

- PS** Adjustable main pressure relief valve. Pre-set at factory.
- PB** Adjustable main pressure relief valve. Supplied factory-set and sealed.
- /** Without pressure relief valve. Cavity not machined

Pressure setting [17]

Max. 320 bar. Settings above 320 bar can result in shorter service life. The permitted maximum pressure may be higher or lower depending on the type of application and the load spectrum. Please contact your nearest Parker representative for help and approval.

Pump unloading [22]

According to the EC Machinery Directive, machines must be equipped with one or more emergency STOP functions to enable actual or impending danger to be averted.

"The emergency STOP function must stop the dangerous process as quickly as possible without creating additional hazards and the energy supply to the function must be cut off."

The pump-unloading inlet meets these criteria by diverting incoming oil from the pump directly to the tank line, at the same time blocking the pump line into the valve. This means that no energy is transmitted to the functions. It should be noted, however, that movements driven by dead weight will continue if there are no overcentre valves.

N.B. The pump-unloading function is a component of the machine safety system.

The pump-unloading function can also be used to save energy when the valve is not being used. By engaging the pump-unloading function when the valve is not being used, the pressure drop Pump-to-Tank falls. This function works just as well when downstream spool-sections are connected in parallel as well as in series.

The solenoid BEN [22] that controls the pump unloading function is available in 12 and 24 VDC versions. The solenoid is equipped with a manual activating device. For details on connectors, please see page 31.

- /** Inlet not equipped with pump unloading.
- BEN** Inlet equipped with electrically controlled pump unloading.
- BX** The inlet section is machined for the pump unloading function and plugged. This enables the pump unloading function to be installed at a later date, as well as the possibility of external control of pump unloading via port PX (see overleaf).

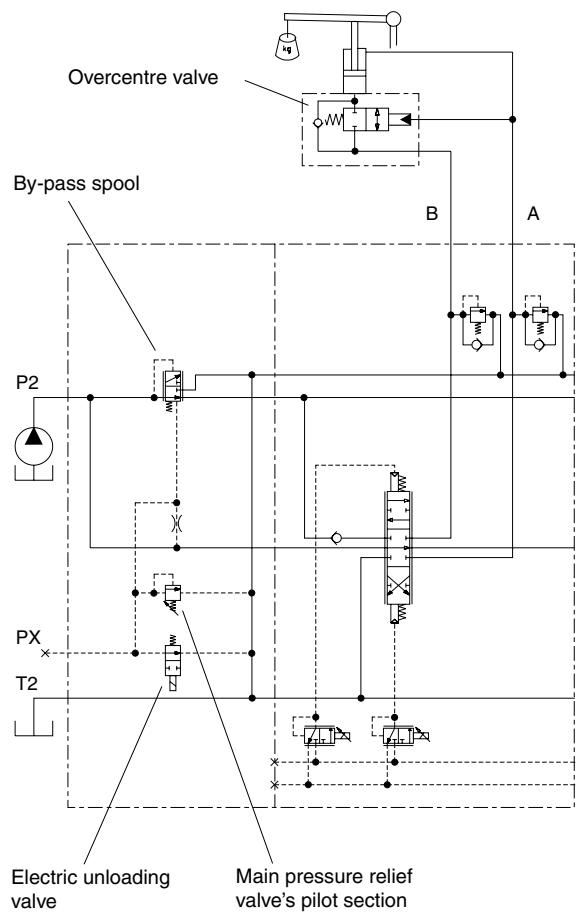
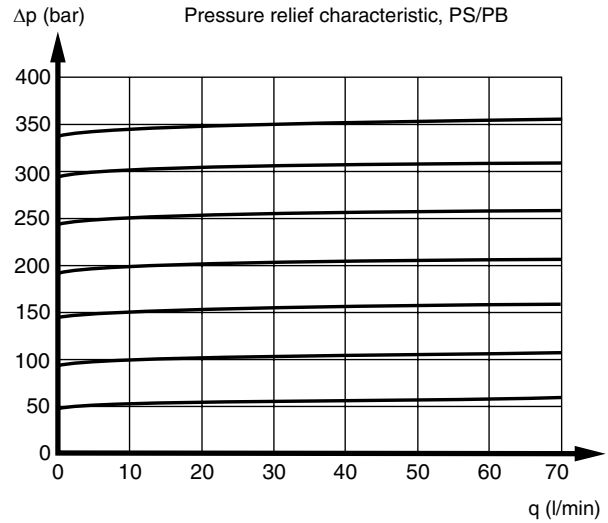

Circuit diagram for pump unloading

External pump unloading or multi-level main pressure relief function

Unloading can also be effected hydraulically by sending a hydraulic signal from connection UL or PX (depending on type of inlet [15] see pages 14 to 17) to external valves in an outer pilot circuit.

The unloading function can also be used to limit the maximum pressure for certain functions. In this way, high system pressures that arise when light loads bottom-out can be avoided.

By means of an external pilot-circuit connected to the pilot circuit (connection UL) of the main pressure relief valve, several pressure levels can be set as required. In this case, however, the external pilot valves must be set lower than the built-in one, and each must be connected to the pilot circuit by means of a two-way valve. The use of several different pressure levels will increase the service life of the system.

Tank connection T2 [25]

- T2** Tank connection T2 open.
- T2B** Tank connection T2 plugged.

Pump connection P1 [26]

Not present on inlet type IU [15].

- P1** Pump connection P1 open. Normal version.
- P1B** Pump connection P1 plugged.

Pump connection P2 [27]

See page 8 for more information about parallel connection.

- P2** Pump connection P2.
- P2B** Pump connection P2 plugged. Normal version.
- L** This option gives a parallel pump connection. This should be used in the P70CF when the actual valve is connected downstream of another valve. The function separates the free flow gallery from the pump gallery. This option must be chosen when specifying a P70LS system. This option is not available for inlet types IU in position [15].
- CUI** This option provides a pump connection with an unloading signal restrictor, for a variable pump. The pump pressure enters the free flow gallery via the CUI restrictor (Ø1.0 mm). The inlet section I [15] is connected with the pump regulator via the P1 connection. When all spools are in neutral, the flow coming from the pump gallery passes via the CUI restrictor to the tank connection in the valve's end section. The pressure that influences the pump regulator does not arise. As soon as a spool is shifted out of neutral, however, the connection from the CUI restrictor to tank is broken and the pump pressure is again directed to the pump regulator via the P1 connection. This option should be used on the P70CP. This option is not available for inlet types IU in position [15].

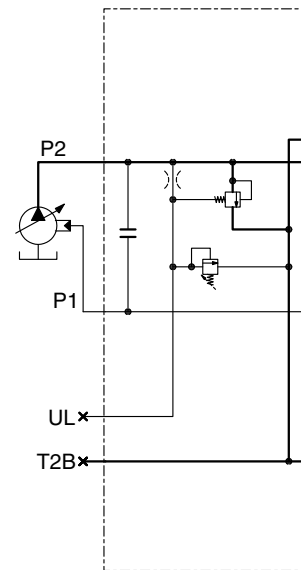

Circuit for inlet section with L

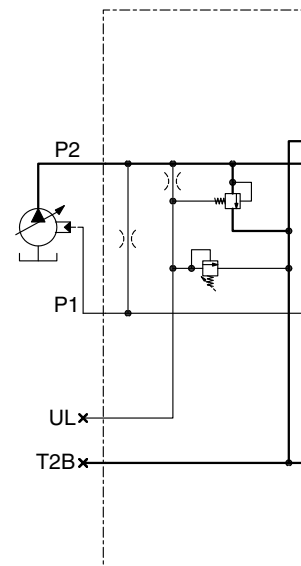

Circuit for inlet section with CUI

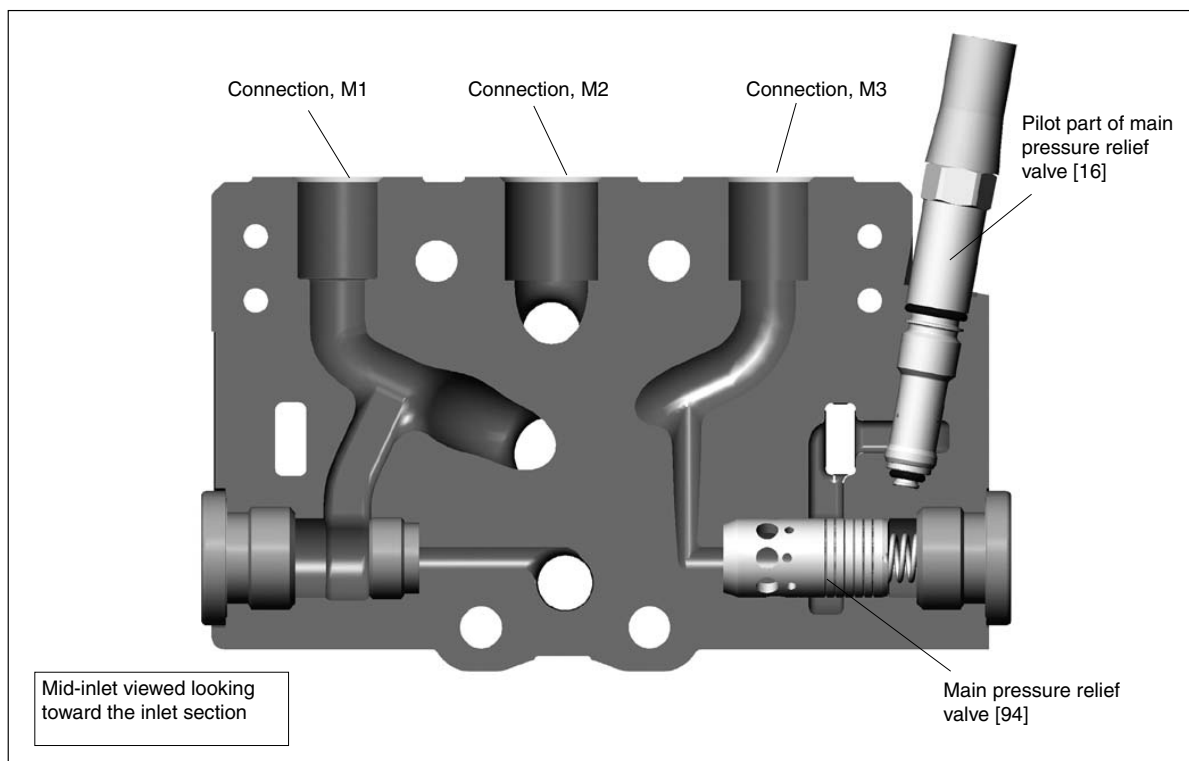

Mid-inlet section [90]

Many compact system solutions can be obtained with the aid of a mid-inlet section, which contains three connections connected in different ways, depending on the choice of options.

The main pressure relief valve (see page 19) can/or should be fitted in the mid-inlet, depending on the way in which the system is constructed. See connection alternatives overleaf.

Several mid-inlets can be placed in one and the same valve to give optimum system construction.

The mid-inlet section can only be selected for the P70CF.

Options, mid-inlet [93]

- C3** Mid-inlet, with power beyond connection, that gives priority to the upstream sections. Flow which is not used in sections upstream of the mid inlet will be added to the incoming flow of the inlet M3. This option is intended for both single and multi pump operation.
- C5** Mid-inlet, without flow summation. Valves fitted with C5 function as two separate valves fitted with a common tank connection. If a separate tank connection is fitted to port M1, the pump to tank pressure will be reduced. This option is intended for multi pump operation only.
- C6** Mid-inlet with possibility of external power beyond connection via external check-valve between M1 and M3, with priority given to upstream sections, but without flow summation. Intended for multi-pump operation.

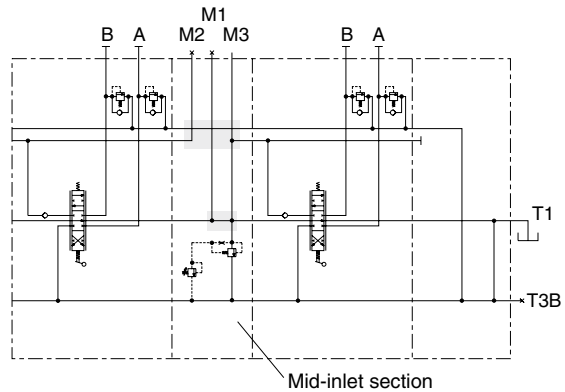

Mid-inlet, C3. Used in multi-pump systems and when upstream sections are to have priority over flow delivered by the pump connected to the inlet section [15]

Main pressure relief valve [94]

The mid-inlet can be fitted with the same main pressure relief valve as is fitted in the standard inlet. For further information and technical data, please see Inlet section [16] on page 16.

In systems in which several different pressure levels are required, main pressure relief valves can be fitted to give different pressure levels before and after the mid-inlet.

- PS** Adjustable main pressure relief valve. Delivered with opening pressure pre-set as per specification.
- PB** Adjustable main pressure relief valve. Delivered pre-set and factory-sealed.
- Y** Without pressure relief valve.

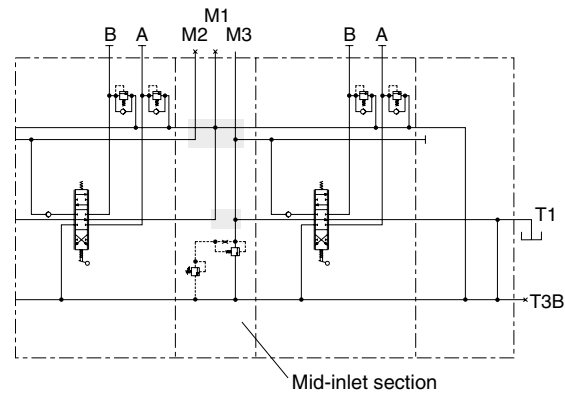

Mid-inlet, C5. Used in multi-pump systems. Valve functions as two separate valves, but with common tank gallery.

Pressure setting [98]

Max. 320 bar. Settings above 320 bar can result in shorter service life. The permitted maximum pressure may be higher or lower depending on the type of application and the load spectrum. Please contact your nearest Parker representative for help and approval.

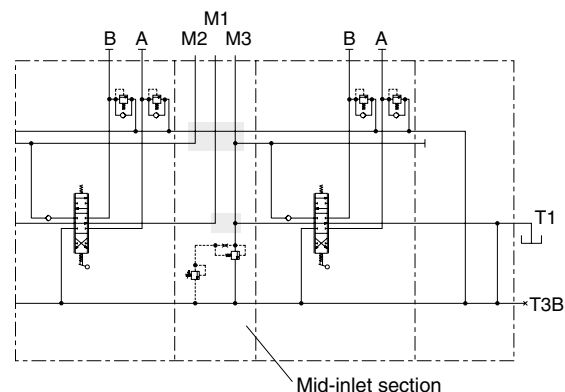

Mid-inlet, C6. Used for separate feeding (port M2) of non-prioritised sections upstream of the mid-inlet. See page 22.

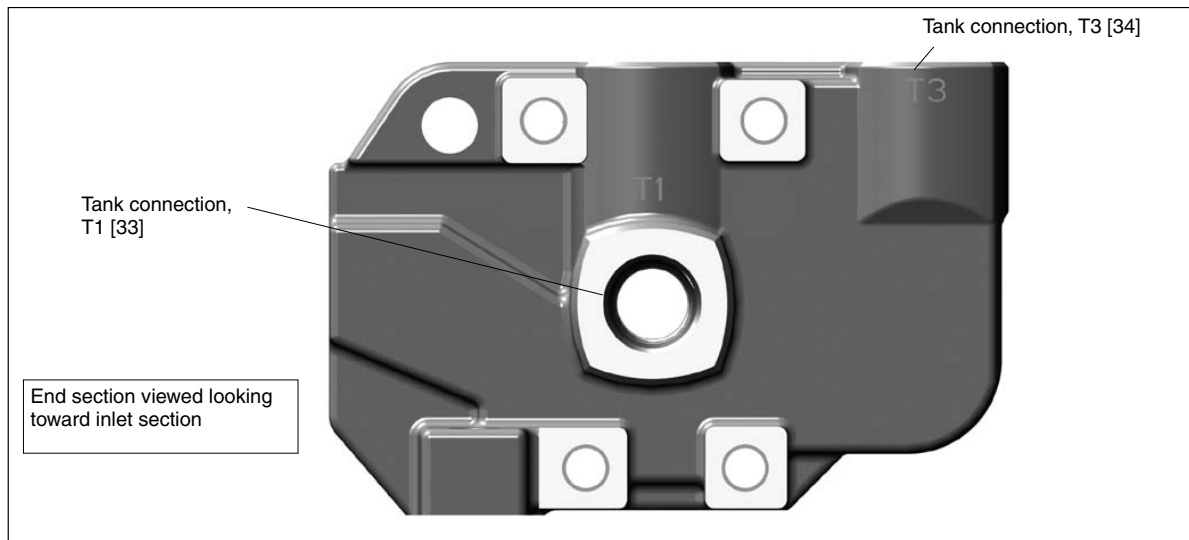
End section for standard valve

The end section is available in two different versions, the standard version and one with an integrated pilot-pressure supply. The standard end-section is equipped with two tank connections, T1 and T3. A series-connection function can be fitted in T3 to feed downstream valves. See page 8. For valves with integrated spool-actuators, the end section includes a pressure-reducing valve for the pilot-pressure supply, as well as a tank connection T4.

Type of end section [30]

- US** Standard end-section.
- USP** End section with pilot-pressure generation.

Tank connection T1 [33]

- T1** Tank connection T1 open (normal version).
- T1B** Tank connection T1 plugged.
- PT** Counter pressure valve that raises pressure to 5 bar in free-flow gallery to ensure that the minimum requisite pilot-pressure is maintained (USP only).
- PT8** Counter pressure valve that raises pressure to 8 bar in free-flow gallery to ensure that the minimum requisite pilot-pressure is maintained (USP only).
- LD** This is a tank connection with a drain cartridge fitted. This must be used in the P70LS.

Tank connection T3 [34]

- T3** Tank connection T3 open.
- T3B** Tank connection T3 plugged.

Series-connection function [36]

- /** Without power beyond connection.
- S** Series-connection function used to block connection between free-flow gallery and tank. Flow in free-flow gallery fed to subsequent valve through either T1 or T3 connection. Tank connection T2 in the inlet must be open.

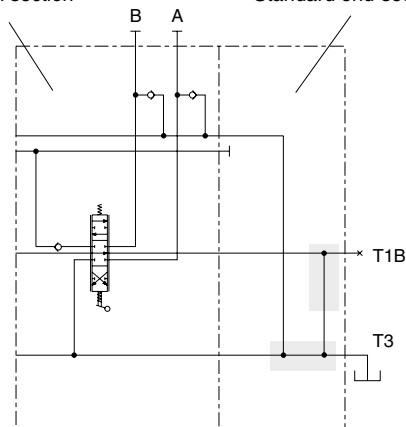
Spool section Standard end-section

Tank connection T3 open. Free-flow gallery connected with tank gallery in the end section.

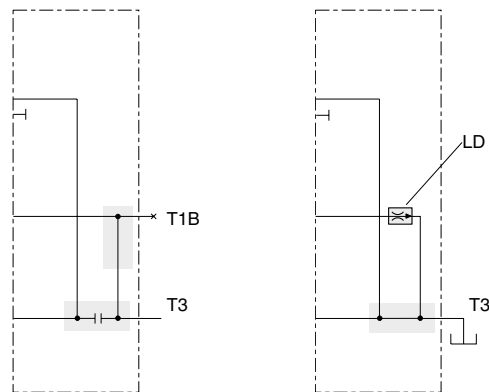

End section equipped with S-function. The free-flow gallery's connection with the tank gallery is blocked.

Tank connection T3 open. Open centre gallery connected with tank through LD at item [33]. P70LS only.

End Section

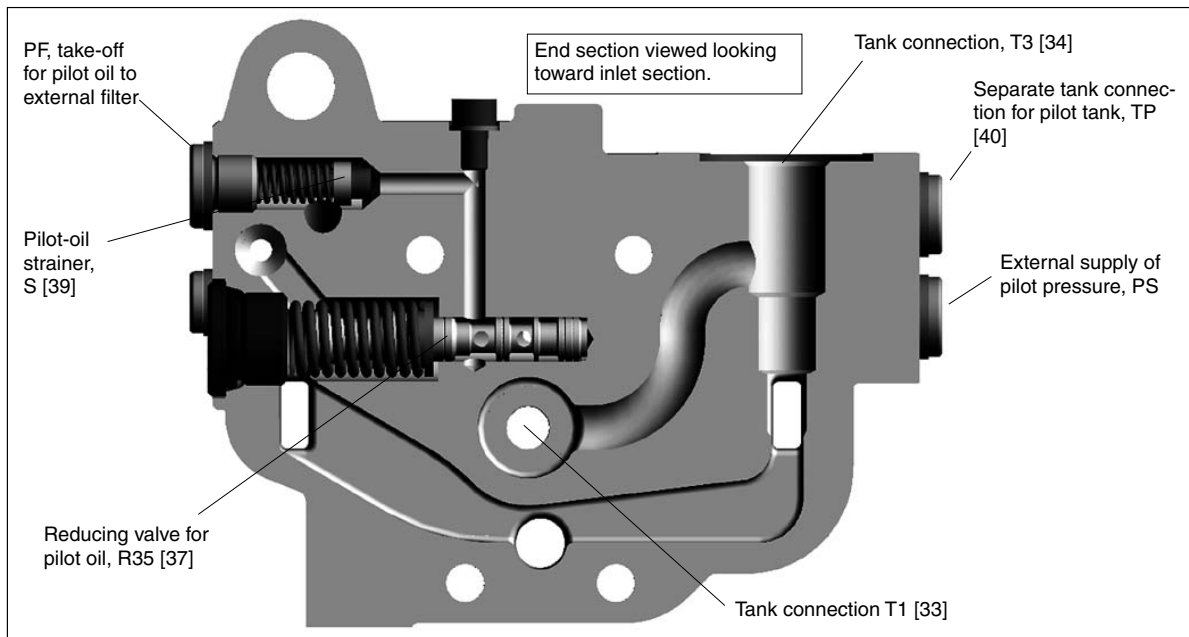

End section with integral pilot-oil supply

Reducing valve [37]

Internal pilot-pressure supply is a valve function built into the end section, which acts both as a reducing valve and a pressure relief valve in the pilot circuit. For safety reasons, it is furnished with a separate safety valve function that prevents the maximum permissible reduced pressure from being exceeded.

A pilot pressure for external use, e.g. for the PCL4 remote-control valve, can be tapped via the PS connection.

- / Without reducing valve
- R35** Reducing valve set at 35 bar.

Pilot-oil strainer [39]

- S** Coarse filter with by-pass function in the internal pilot-pressure supply. Filter protects pilot circuit from dirt, especially during start-up of system.
- YS** Adaptor for connection of external pilot-pressure filter. Enables pilot circuit to be supplied with cleaner oil compared with the rest of the system (recommended).

Separate tank connection for pilot circuit [40]

- TP** Separate tank connection for pilot circuit is open. The connection to the main tank gallery in the directional valve is blocked. This function is suitable for systems in which there is a risk of dynamic pressure variations in the tank line causing variations in the pilot circuit when there is a common tank line.
- TPB** This end section has a separate tank connection for the pilot circuit, which is machined and plugged. The pilot circuit's return to tank is connected to the valve tank gallery.
- TPC** The pilot circuit's tank gallery is connected to the main tank gallery via a check valve. The check valve is used to prevent pressure peaks reaching the spool actuators.

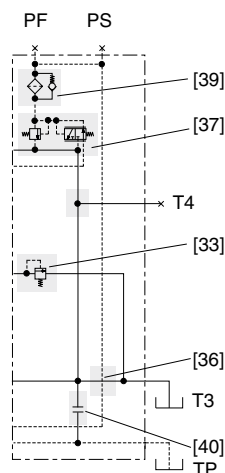

Tank connection T3 open. Free-flow gallery connected with tank via counter pressure function, PT [33].

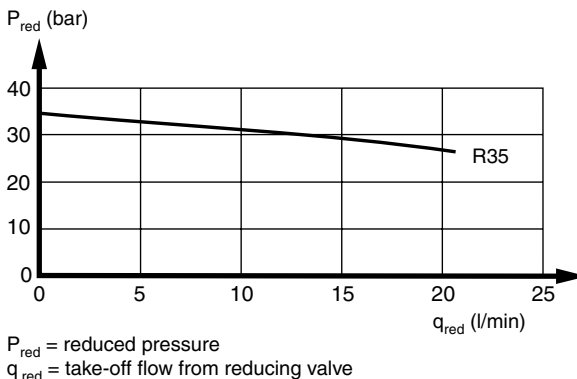

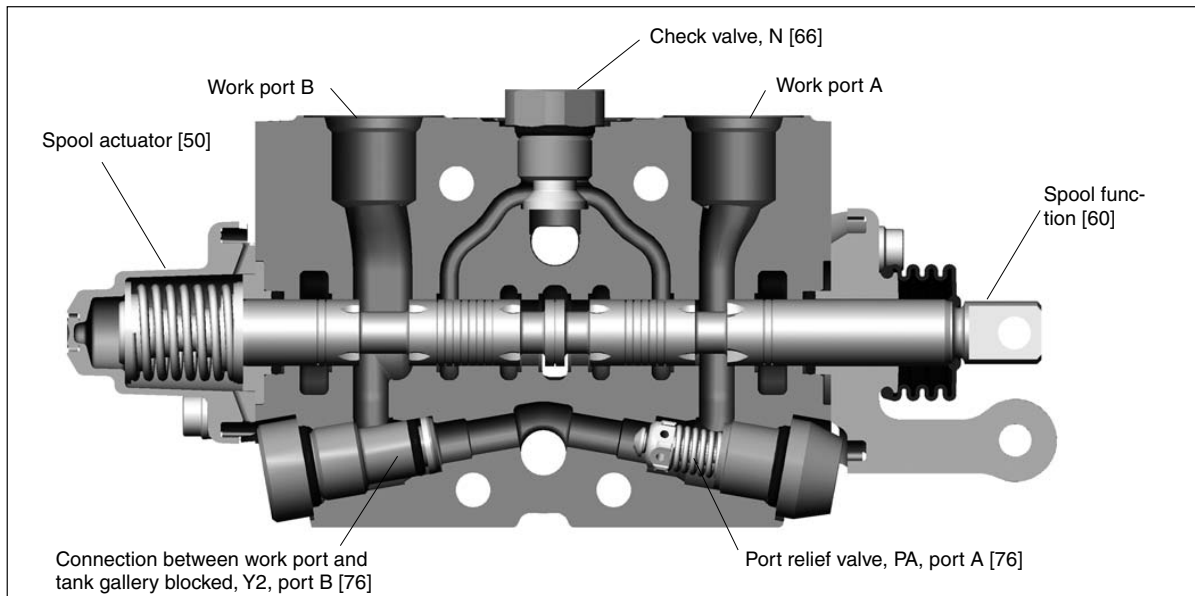

Spool section, P, with open spool end.

The P70 is stackable and can be supplied in combinations of 1 to 10 spool sections. For each spool section, there is a wide range of spools and spool actuators to choose between. This enables optimal adaptation of individual spool sections to suit the application and control function. The spool sections have machined control edges for precise control characteristics.

Type of spool section [47]

- P** Parallel-connected section

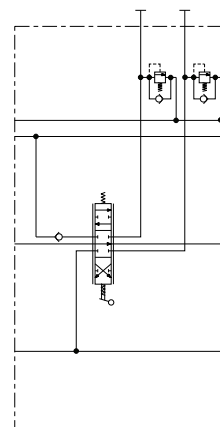

Parallel-connected section.

Spool Sections

Mobile Directional Control Valve P70

Lever bracket [51]

LMA Lever bracket for open spool end. Lever itself not included. Must be ordered separately (see page 32).

LMB Lever bracket for open spool end. Lever itself not included. Must be ordered separately (see page 32).

LU No lever bracket – open spool end.

* Spool in (←) gives actuation P-A, B-T.
Spool out (→) gives actuation P-B, A-T.

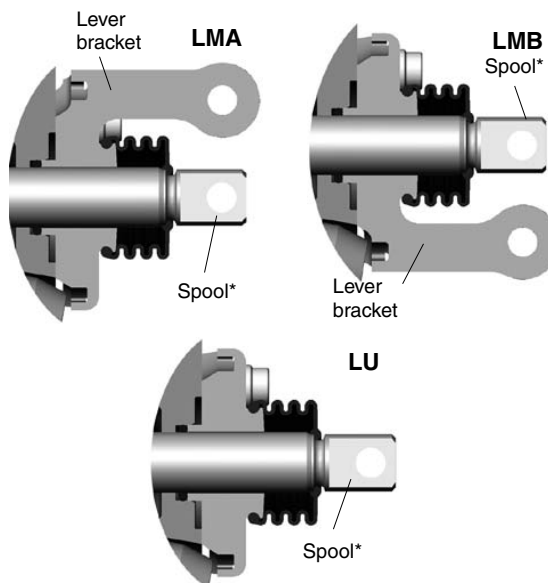

MJA Lever bracket and link parts for mechanical joystick, type A, and for open spool end. Lever bracket MJA have always to be selected in the left section and lever bracket MJ in the right section. Lever itself not included. Must be ordered separately (see page 33).

MJA

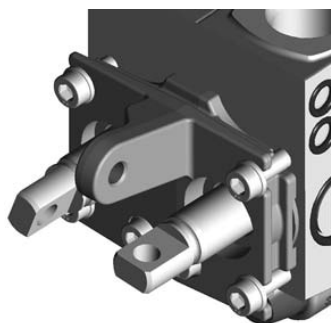

MJB Lever bracket and link parts for mechanical joystick, type B, and for open spool end. Lever bracket MJB have always to be selected in the left section and lever bracket MJ in the right section. Lever itself not included. Must be ordered separately (see page 33).

MJB

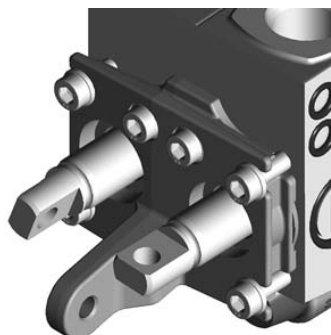

MJA complete

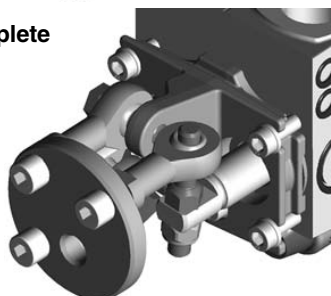

Spool actuators [50]

A large number of spool actuators is available for the P70CF. They are divided into three different groups: hand-operated, ON/OFF remote controlled and proportionally remote controlled.

Hand-operated spool actuators with open spool end

C/C140 Spring-centered spool actuator. Actuator for stepless control with spring centering to neutral position. C140 has stronger centering force. Recommended when cable control or mechanical linkages are used.

B2C Three-position, spring-centered spool actuator. The B2C has mechanical detents at the two end positions, so that the spool stays in place when fully actuated in either direction. It must be shifted out of the respective end positions manually.

CB Float-position spool actuator. The CB is a special actuator for F-spools (see page 29). It features stepless operation, with spring centering from the two end positions to neutral. It also has a fourth position with a mechanical detent. The spool must be shifted out of the fourth position manually.

Remote controlled spool actuators with open spool end and possibility of manual control

ACE An electro-pneumatic ON/OFF control with spring centering and the possibility of stepless operation by means of a lever.

Primary air:	4 – 10 bar
Control current:	12 VDC min. 0.85 A 24 VDC min. 0.42 A

Voltage tolerance: ± 20%

The spool actuator has a common pressure gallery for primary air. The primary air can be connected to either the first or the last valve section directly by means of a plug-in connector for Ø6 mm air hose.

ACP A pneumatic proportional spool actuator with spring centering and the possibility of stepless operation by means of a lever. The ACP is best controlled by the Parker VP04 remote control valve.

Breakaway pressure:*	2 bar
Final pressure:*	7 bar
Permissible air pressure in pilot cap	Max. 10 bar
Connections:	G1/8 or NPTF 1/8-27

* The breakaway pressure refers to the pressure needed for the directional valve to open the connection "pump to work port". The final pressure is the lowest pressure needed to effect full actuation of a spool in the directional valve. The foregoing data must be taken into consideration when choosing control units, since the opening pressure of the control unit must be lower than the breakaway pressure of the spool actuator in order to avoid jerky starting and stopping. However, the control unit's final pressure must be higher than the final pressure of the directional valve in order to ensure that the spools can be fully actuated. This is important for the P70CF because, if the spool is not actuated fully, the free-flow gallery will not close, with the result that a certain amount of flow will go directly to tank.

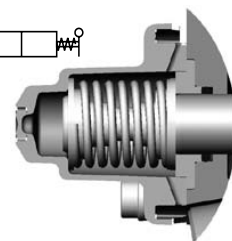
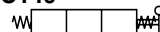
C/C140

Also see spool position indicator SI on page 28

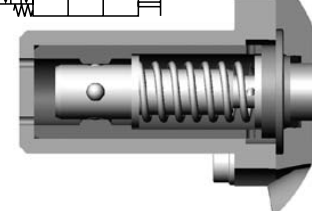
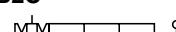
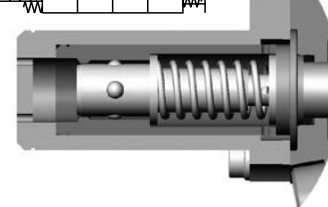
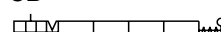
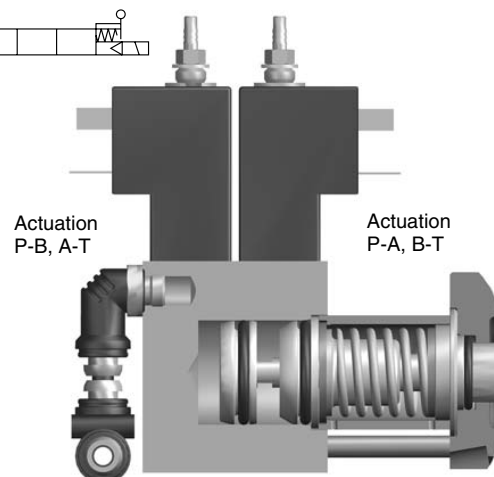
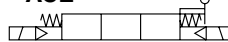
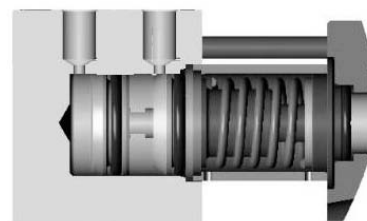
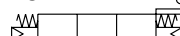
B2C

CB

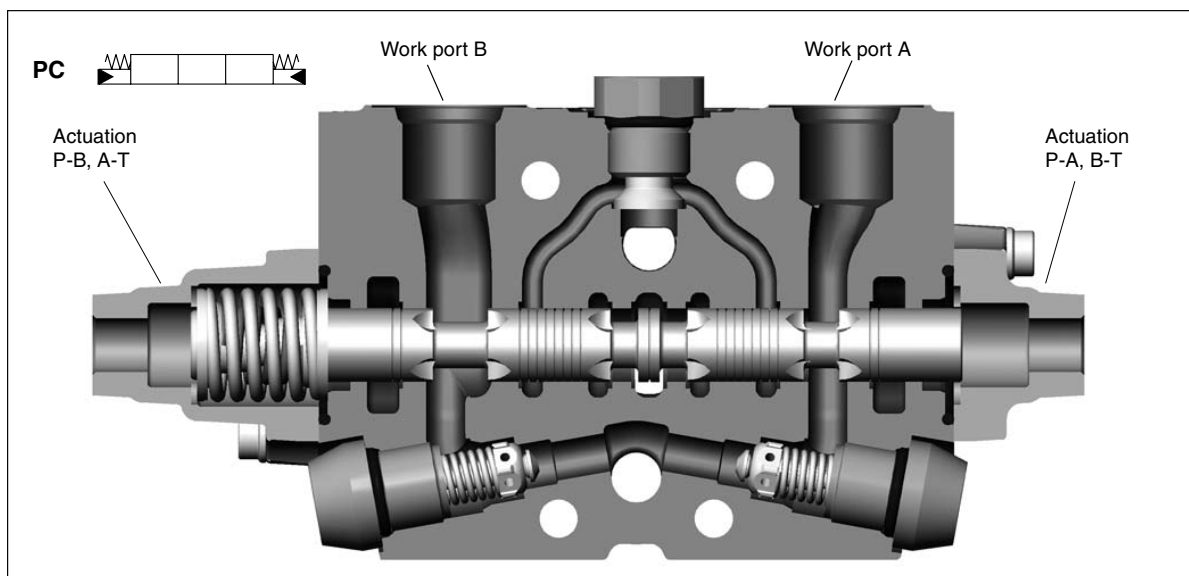
ACE

ACP

Remote controlled proportional spool actuators with closed spool end



PC Hydraulic, proportionally controlled, spring-centred spool actuator. Best controlled by PCL4 remote control valve (see separate brochure).

Breakaway pressure:*	6 bar
Final pressure:*	17 bar (max. 35 bar)

Connection thread: G1/4 or 9/16-18 UNF

FPC Hydraulic, proportionally controlled, spring-centered spool actuator with a fourth position for shifting the spool into the float position.

Valves with FPC have to be fed with external pilot pressure in open centre systems (Not in CP/LS).

Breakaway pressure:*	6 bar
Final pressure:*	16 bar (max. 18 bar)

Pressure for float position:	min. 24 bar (max. 35 bar)
------------------------------	------------------------------

Connection thread: G1/4 or 9/16-18 UNF

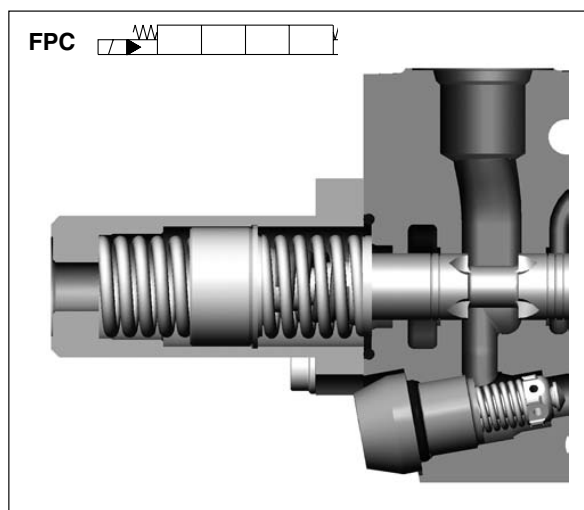

* The breakaway pressure refers to the pressure needed for the directional valve to open the connection "pump to work port". The final pressure is the lowest pressure needed to effect full actuation of a spool in the directional valve. With the FPC spool actuator, the float position is obtained by further increasing the final pressure from max. 18 bar to min. 24 bar. The foregoing data must be taken into consideration when choosing control units, since the opening pressure of the control unit must be lower than the breakaway pressure of the spool actuator in order to avoid jerky starting and stopping. However, the control unit's final pressure must be higher than the final pressure of the directional valve in order to ensure that the spools can be fully actuated. This is important for the P70CF because, if the spool is not actuated fully, the free-flow gallery will not close, with the result that a certain amount of flow will go directly to tank.

Remote controlled proportional spool actuators with closed spool end and possibility of manual operation

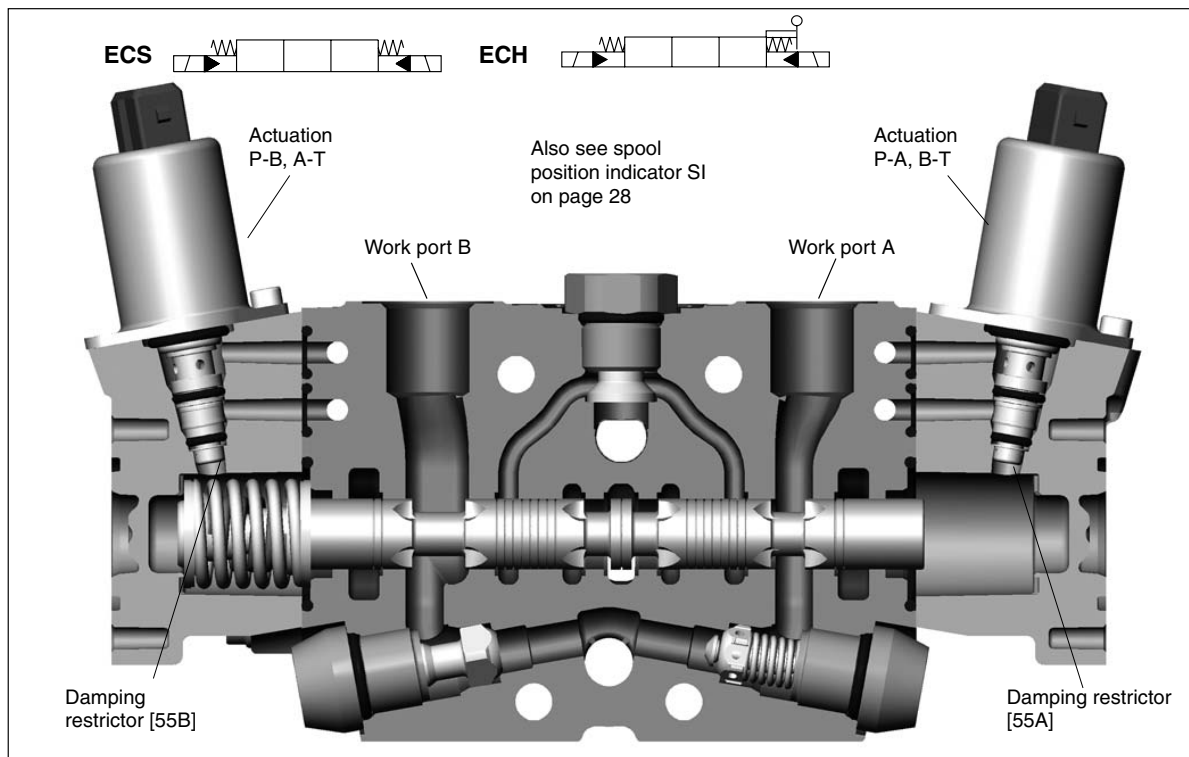

ECS Electro-hydraulic proportional spool actuator

The ECS is an electro-hydraulically, proportionally controlled, spring-centred spool actuator. The PS25 cartridge valve is used as its remote control valve.

The ECS spool actuator is best controlled by means of a Parker electric remote-control system (see separate brochure). The electrical connector must be ordered separately (see page 31).

Voltage	12 V	24 V
Breakaway current:*	max. 500 mA	max. 260 mA
Final current:*	min. 1010 mA	min. 510 mA
Solenoid (PS25):	max. 1450 mA 100% ED	max. 730 mA 100% ED

Coil resistance		
at +20 °C:	5.4 Ω	21.7 Ω
Inductance:	27.7 mH	7.0 mH
Tank pressure:	max. 15 bar	max. 15 bar

ECH As above, but with possibility of stepless operation by means of a hand lever. Valve is delivered with lever bracket, but lever itself must be ordered separately (see page 33).

Solenoid variant [59]

A027 The A027 spool actuator has the same data as the ECS, the difference being that the Solenoid valve in the A027 is equipped with both manual-override and air bleed functions. This option must be chosen in position [59] and with ECS or ECH in position [50].

*

The breakaway current refers to the current needed for the directional valve to open the connection "pump to work port". The final current is the lowest current needed to effect full actuation of a spool in the directional valve. This data must be taken into consideration when choosing control units, since the opening current of the control unit must be lower than the breakaway current of the spool actuator in order to avoid jerky starting and stopping. However, the control unit's final current must be higher than the final current of the directional valve in order to ensure that the spools can be fully actuated. This is important for the P70CF because, if the spool is not actuated fully, the free-flow gallery will not close, with the result that a certain amount of flow will go directly to tank.

Connector Type [56]

The connector of the solenoid is of type:

- A** AMP Junior-Timer type C.
- D** Deutsch type DT04-2P. Mates with DT06-2S Plugs.

The connector must be ordered separately.

Remote controlled proportional spool actuators with closed spool end

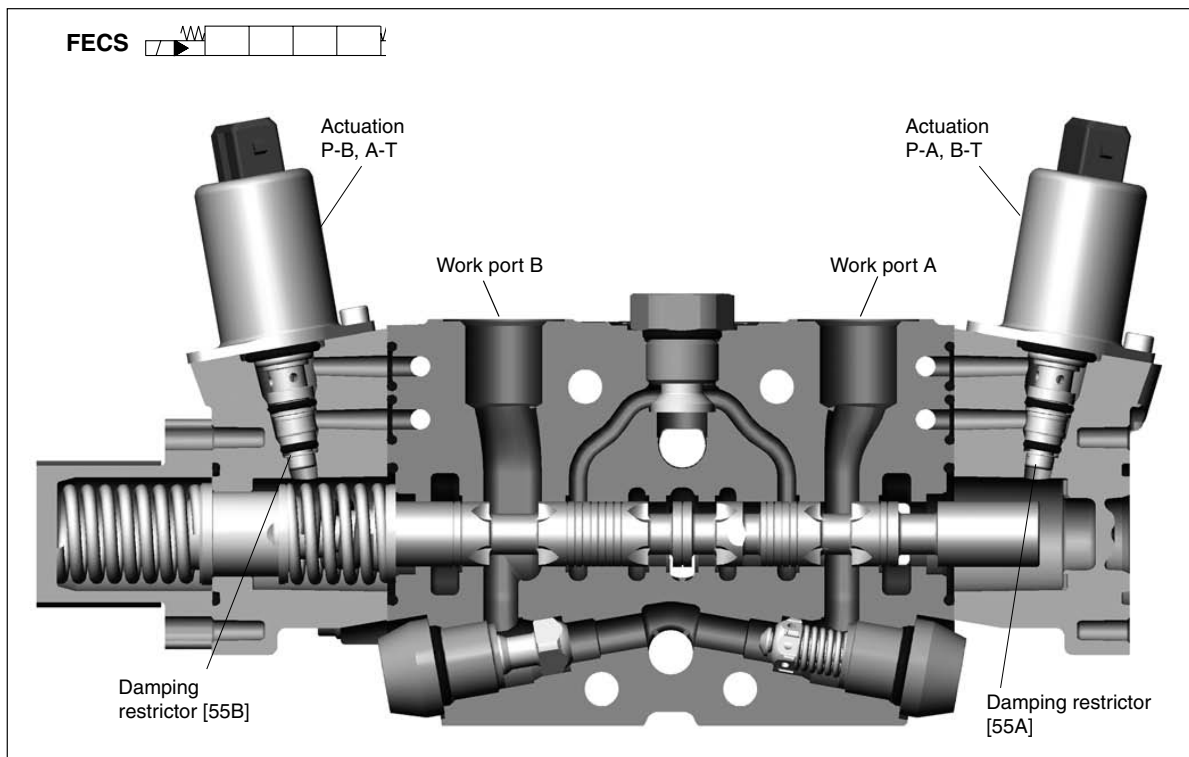

FECS Electro-hydraulic, proportionally controlled, spring-centered spool actuator with a fourth position for shifting the spool into the float position. The PS25 cartridge valve is used as its remote control valve.

Valves with FECS have to be feeded with external pilot pressure in open centre systems (Not in CP/LS).

The FECS spool actuator is best controlled by means of a Parker electric remote-control system (see separate brochure). The electrical connector must be ordered separately (see page 31).

Voltage	12 V	24 V
Breakaway current:*	max. 500 mA	max. 260 mA
Final current:*	min. 1010 mA	min. 510 mA
Float position current:	max. 1450 mA	max. 730 mA
	min. 1410 mA	min. 690 mA
Solenoid (PS25):	max. 1450 mA	max. 730 mA
	100% ED	100% ED
Coil resistance at +20 °C:	5.4 Ω	21.7 Ω
Inductance:	27.7 mH	7.0 mH
Tank pressure:	max. 15 bar	max. 15 bar

* The breakaway current refers to the current needed for the directional valve to open the connection "pump to work port". The final current is the lowest current needed to effect full actuation of a spool in the directional valve. With the FECS spool actuator, the float position is obtained by further increasing the final current, see table. The foregoing data must be taken into consideration when choosing control units, since the opening current of the control unit must be lower than the breakaway current of the spool actuator in order to avoid jerky starting and stopping. However, the control unit's final current must be higher than the final current of the directional valve in order to ensure that the spools can be fully actuated. This is important for the P70CF because, if the spool is not actuated fully, the free-flow gallery will not close, with the result that a certain amount of flow will go directly to tank.

Connector Type [56]

The connector of the solenoid is of type:

- A** AMP Junior-Timer type C.
- D** Deutsch type DT04-2P. Mates with DT06-2S Plugs.

The connector must be ordered separately.

Spool position indicator [52]

The spool actuators type C, C140 ECS and ECH can be equipped with an electric spool position indicator. It has one analog signal output linear, proportional to position of the spool between -1.5 and +1.5 mm of spool stroke according to the diagram below.

SI Spool position indicator (SSP2)

Connector must be ordered separately (see page 31)

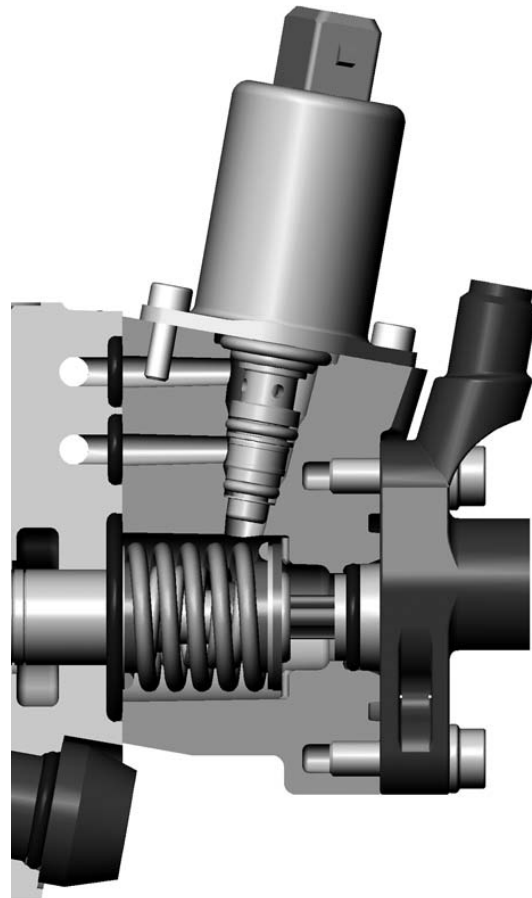
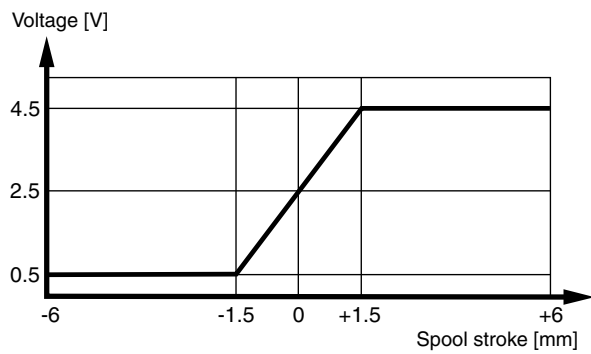

ECS cap with spool position indicator (SSP2)

The spool is the most important link between the actions of the operator and the movement of the controlled function. Parker therefore goes to great lengths to optimise spools for different flows, load conditions, functions and applications. Since this is a process of continuous development work, new spools are being introduced all the time. For this reason, the many different spools available are not detailed in this catalogue. Parker's computerised specification program will generate proposals for suitable spools for the application and functions of the hydraulic system in your machine.

Spool function [60]

Spools are divided into different groups, depending on their basic function.

- D** Double-acting spool. Blocked in the neutral position.
- EA** Single-acting spool. Blocked in the neutral position and work port B blocked.
- EB** Single-acting spool. Blocked in the neutral position and work port A blocked.
- M** Double-acting spool. Work ports connected to tank (float position) in neutral.
- F** Double-acting spool with fourth position in which both work ports are connected to tank (float position). Blocked in neutral position.
- CA** Regenerative spool for rapid feeding of a cylinder, or for flow saving. The large side of the cylinder is always connected to work port A.

Certain spools have been equipped with drainage from work port to tank when the spool is in neutral. Drainage (approx. 2 mm²) serves to prevent pressure build-up in the work port. Such drainage is used primarily in combination with different types of external overcentre valve. The spool designation is affected as follows: A lower-case letter is suffixed to the usual spool designation indicating function, e.g. the D-spool becomes a Da-spool to indicate drainage from service-port A to tank.

- a** Drainage of service-port A to tank
- b** Drainage of service-port B to tank
- m** Drainage of work ports A and B to tank

Please note that LS spools have a different coding system.

All LS spool have "ls" after the spool codes leading letter e.g. a double acting spool, normal code D, would become Dls and for a single acting spool, normal code EA, would become EAls.

For spool selection including drainage, the drainage letter is placed at the end of the code e.g. for a single acting spool with drainage from work port A, the code would be EAlsa.

Spool designation [69]

Each spool version is imprinted with an alphabetical code to facilitate identification during tuning or servicing in the field.

Pressure gallery [66]

- N** Load-hold check valve to prevent undesirable sinking of a heavy load while a light load is in operation. (Standard)

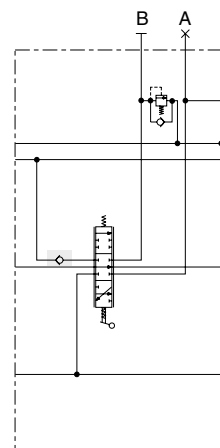
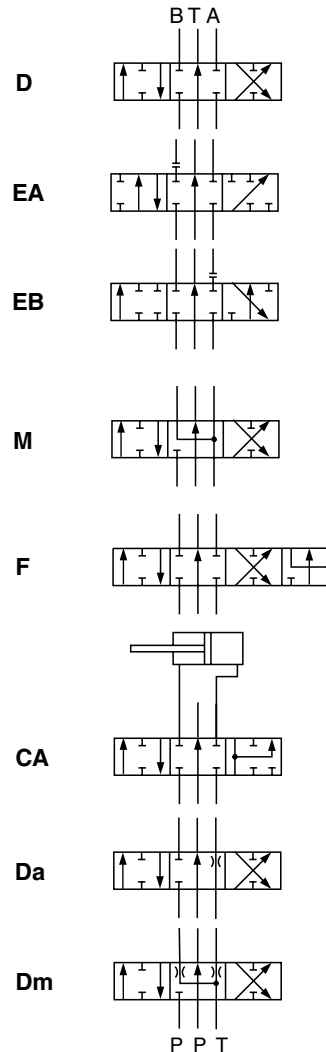

Pressure gallery always fitted with check valve (N).



**Pressure limiters in work ports [76A/B]
(Port relief valves)**

The work ports can be equipped with individual port-relief and/or anti-cavitation valves.

PLC cartridge valves are used as port relief valves. They are renowned for their long service life, tightness, fast opening sequence and good characteristics over the entire flow range.

Port relief valve [76]

- /** Hole for port relief valve not machined.
- X2** Work port connected with valve's tank gallery.
- Y2** Connection between work port and tank gallery blocked. (Cavity plug)
- N2** Anti-cavitation valve fitted. The anti-cavitation valve serves to ensure that, in the event of a lower pressure in the work port than in the tank, oil can be sucked from the system oil tank to the consumer. To improve the anti-cavitation function, the oil tank can be pressurised. Note that the counter pressure valve PT [33] does not influence the pressure in the anti-cavitation valve's tank line.
- PA** PLC combined port-relief and anti-cavitation valve fitted. Valve is factory-set at the specified pressure. Optional pressure settings: 50, 63, 80, 100, 125, 140, 160, 175, 190, 210, 230, 240, 250, 260, 280, 300, 320 and 350 bar.

Since the cavities for X2, Y2, N2 and PA have the same machining, it is easy to change the function of an existing valve.

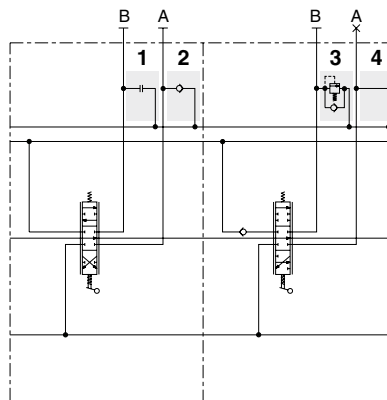

In the diagram above:

Section 1, work port B, is fitted with a Y2-plug (1) to block the connection to tank.

Section 1, work port A, is fitted with an anti-cavitation valve N2 (2).

Section 2, work port B, is equipped with a combined port-relief and anti-cavitation valve (3) to limit the pressure and prevent cavitation.

Section 2, work port A, is connected to tank - X2 variant - in the case of EB spools (4).

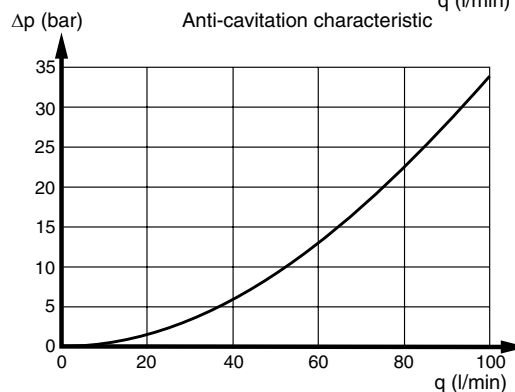
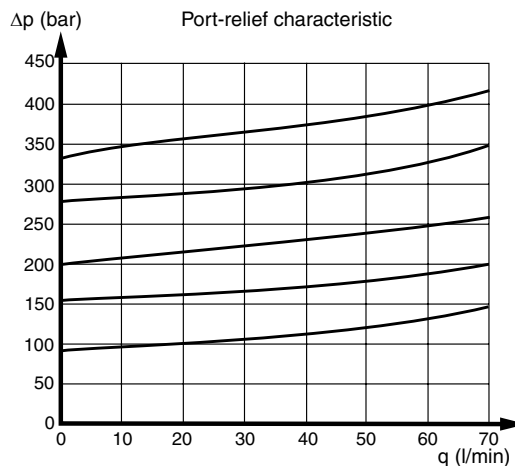

The curve shows the pressure drop between the tank connection and work port when port relief valve (PA) or anti-cavitation valve (N2) without port-relief function is used as an anti-cavitation valve.

Function blocks (manifolds)

P70 valves can be equipped with manifold-type function blocks that enable total system solutions to be integrated into the valve.

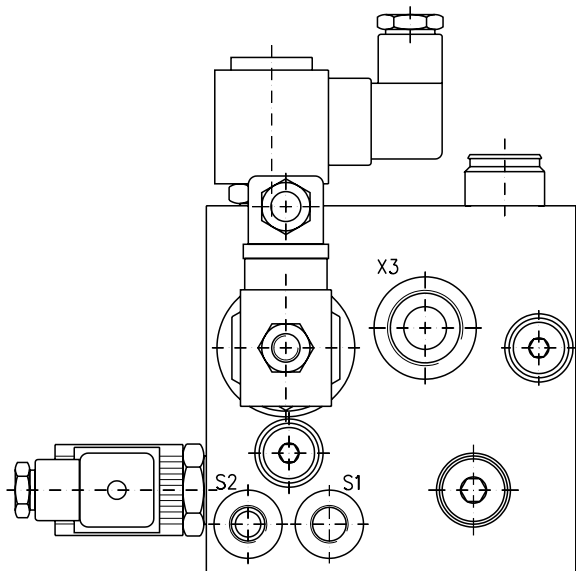

Please contact your Parker representative for more information about integral system solutions. In addition to standard function blocks, special function blocks can be designed by our experienced product and system designers to exactly meet your needs.

The function block above was specially adapted for a customer. Like most of our function blocks, it was constructed with the aid of cartridge valves. Only the housing itself is a unique component.

Connectors

Connectors are not included with spool actuators, and should be ordered separately or ordered from your local connector supplier.

Spool actuators ECH, ECS, FECS [50]

Suitable connectors for option A in pos [56] are:
AMP Junior-Timer type C, 963040-3,
Bosch 1 928 402 404.
The connector also fit pump-unloading function BEN [22].

Suitable connectors for option D in pos [04] are:
Deutsch type DT06-2S.

For available connector kits from MCDE, see catalogue HY17-8558/UK.

Spool actuator ACE

Suitable connector kit is:
Hirschman.

Spool position indicator SI

Suitable connector is:
Binder Sensor connector Series 763 (M12x1) 4 contacts female.

Hand levers

Levers are not supplied with the valve and must therefore be ordered separately.

They are furnished with window-type knobs, so that machine builders can insert the appropriate function symbol beneath a transparent cap to indicate the function of the lever. Levers are supplied complete with mounting kits.

Lever:	Length L mm	Length L (inch)	Ordering No. 1 piece	Ordering No. 25 pieces
MP1	179	(7.05)	8234 9390 21	8234 9390 21 25
MP3	202	(7.95)	8234 9390 23	8234 9390 23 25
MP6	122	(4.80)	8234 9390 26	8234 9390 26 25
MP11	302	(11.89)	8234 9390 31	8234 9390 31 25
MP12	194	(7.95)	8234 9390 32	8234 9390 32 25
MP8	171	(9.84)	8234 9390 28	8234 9390 28 25
MP13	246	(9.69)	8234 9390 33	8234 9390 33 25
MP14	165	(6.50)	8234 9390 34	8234 9390 34 25
MP15*	165	(6.50)	8234 9390 35	8234 9390 35 25

* Red knob

Hand levers for open spool-actuators

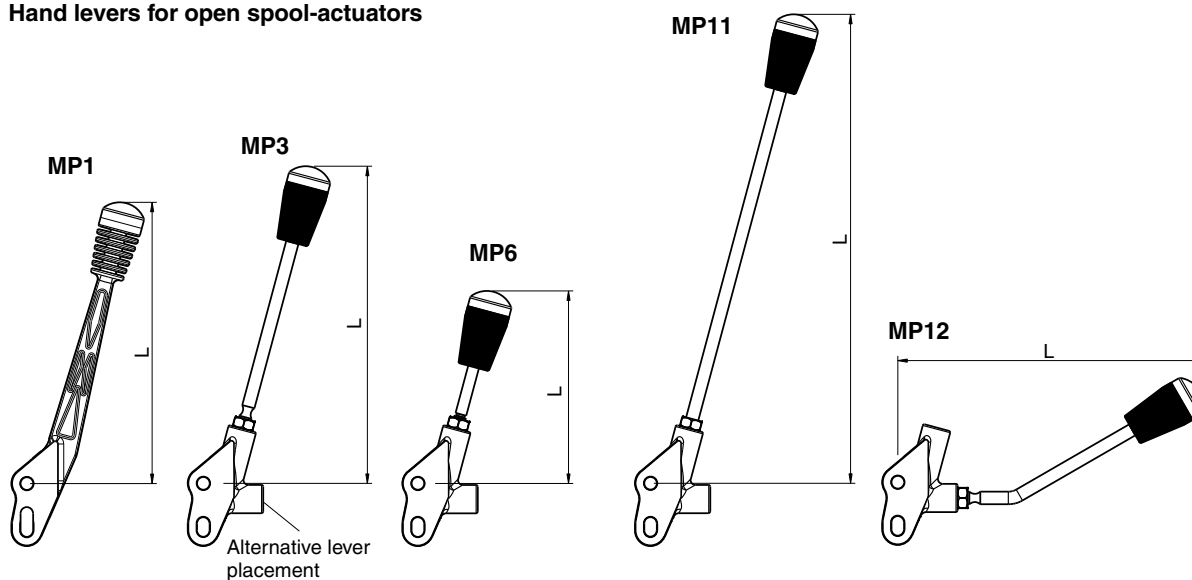

Hand levers for mechanical co-ordinate control for open spool-actuators

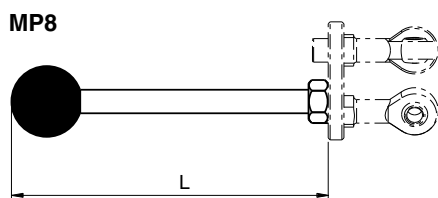

Hand levers for closed spool-actuators

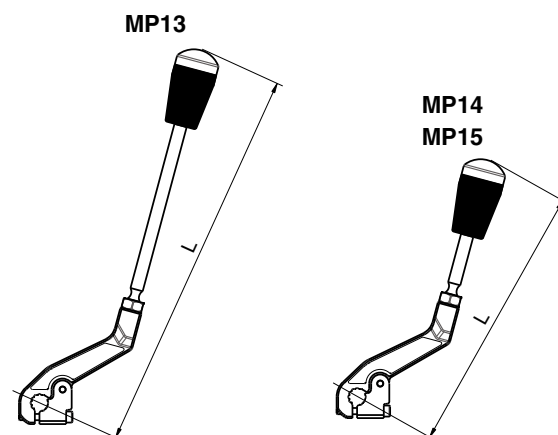

Standard valve

For connection dimensions, please see page 10.

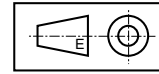

(inch)

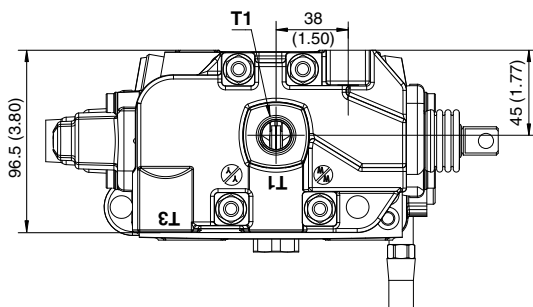
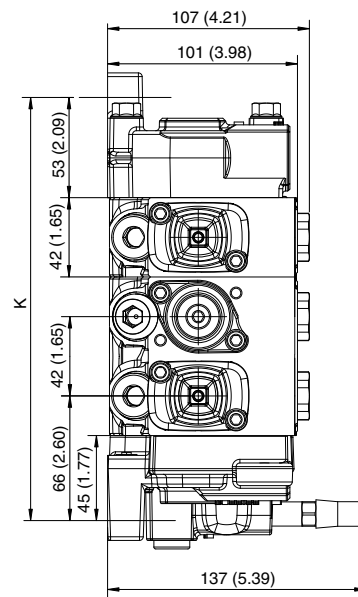
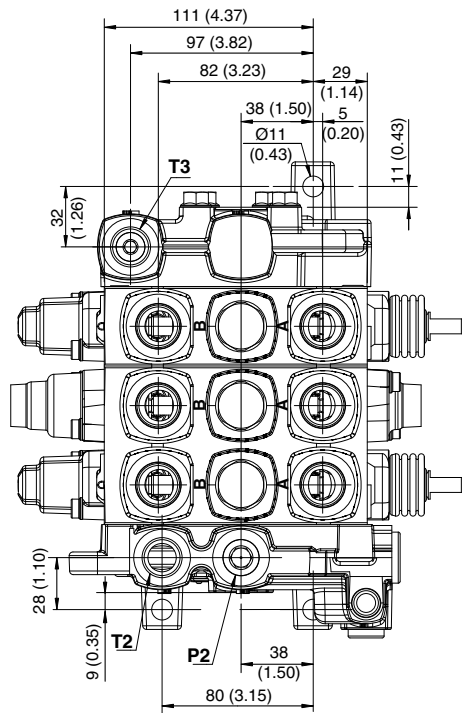
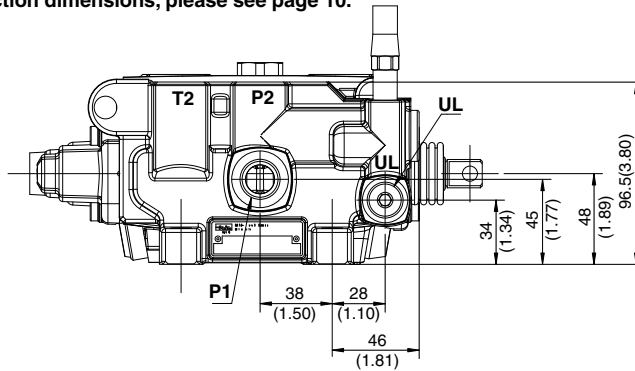

No. of sections	K mm	K inch
1	140	(5.51)
2	182	(7.17)
3	224	(8.82)
4	266	(10.47)
5	308	(12.13)
6	350	(13.78)
7	392	(15.43)
8	434	(17.09)
9	476	(18.74)
10	518	(20.39)

Model with closed spool end
For connection dimensions, please see page 10.

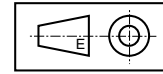

(inch)

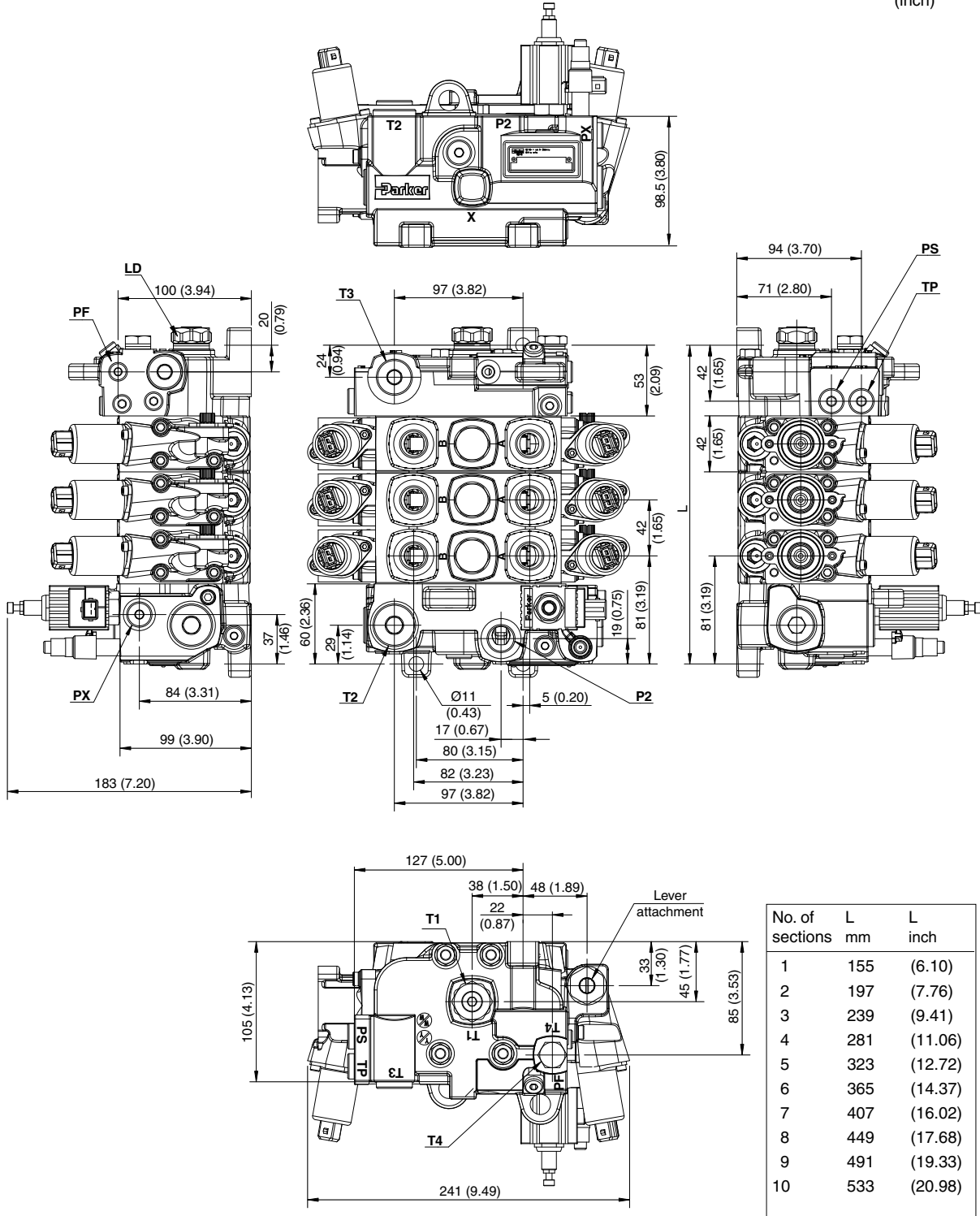

Spool actuators

(inch)

LMB

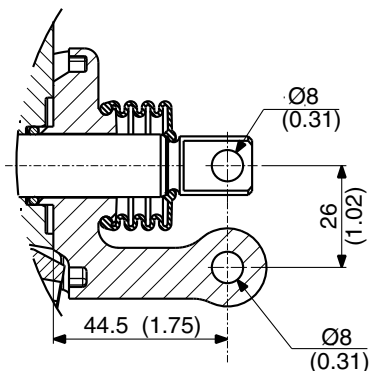

LU

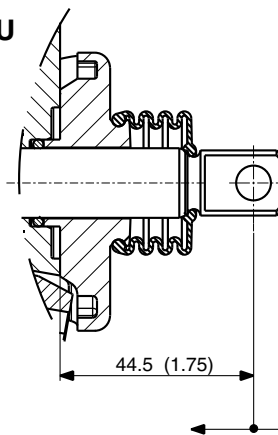

Spool stroke 12.5 mm (0.49) for spool function F [60]. Others 6.0 mm (0.24). Opens pump to work port A.

Spool stroke 6.0 mm (0.24); opens pump to work port B.

C/C140

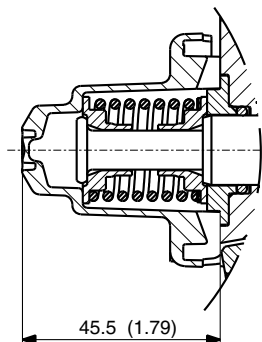

B2C

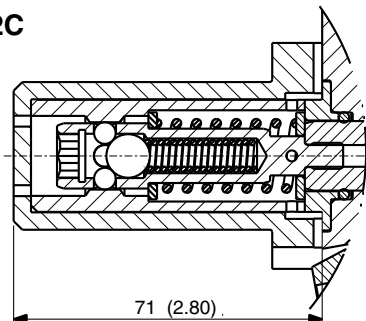

CB

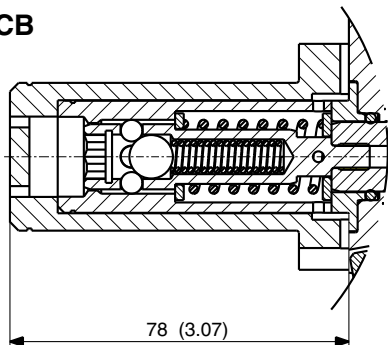

Spool actuators

(inch)

ACE

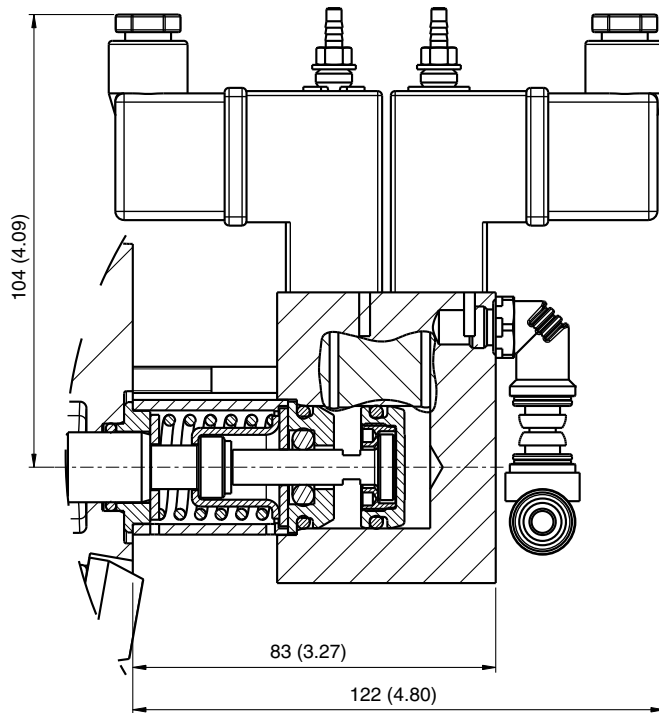

ACP

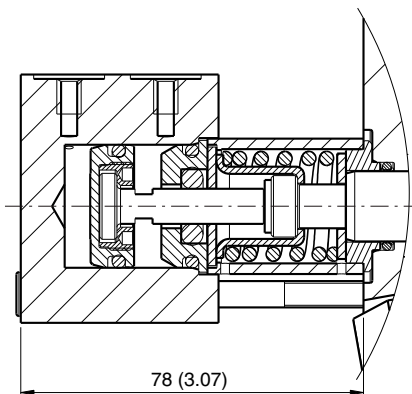

Spool actuators

(inch)

**ECS
ECH**

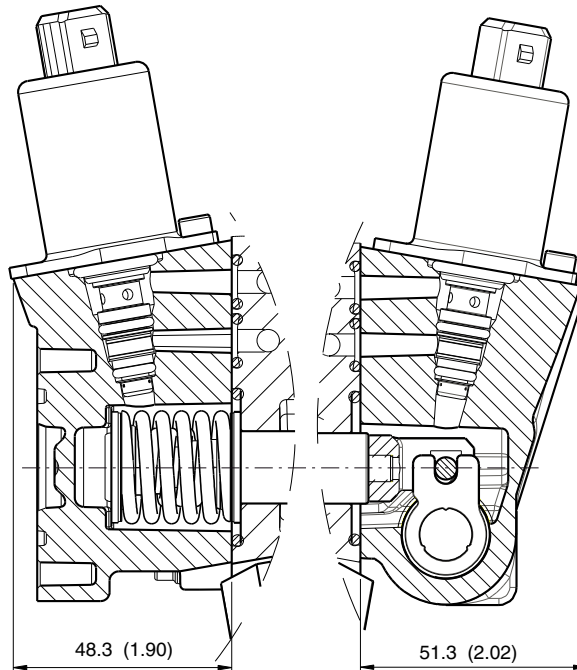

PC

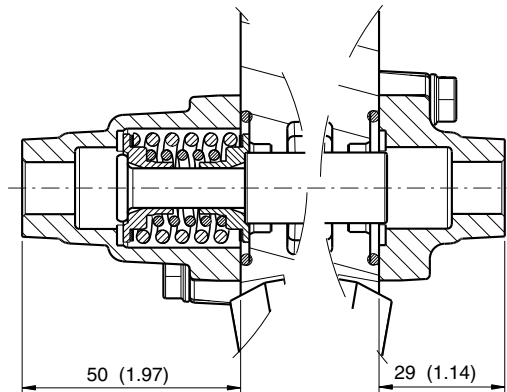

FPC

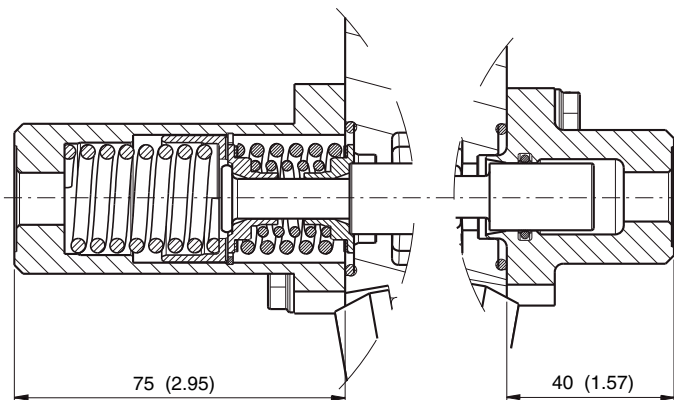

Parker Worldwide

Europe, Middle East, Africa

AE – United Arab Emirates, Dubai
Tel: +971 4 8127100
parker.me@parker.com

AT – Austria, Wiener Neustadt
Tel: +43 (0)2622 23501-0
parker.austria@parker.com

AT – Eastern Europe, Wiener Neustadt
Tel: +43 (0)2622 23501 900
parker.easteurope@parker.com

AZ – Azerbaijan, Baku
Tel: +994 50 2233 458
parker.azerbaijan@parker.com

BE/LU – Belgium, Nivelles
Tel: +32 (0)67 280 900
parker.belgium@parker.com

BY – Belarus, Minsk
Tel: +375 17 209 9399
parker.belarus@parker.com

CH – Switzerland, Etoy
Tel: +41 (0)21 821 87 00
parker.switzerland@parker.com

CZ – Czech Republic, Klecany
Tel: +420 284 083 111
parker.czechrepublic@parker.com

DE – Germany, Kaarst
Tel: +49 (0)2131 4016 0
parker.germany@parker.com

DK – Denmark, Ballerup
Tel: +45 43 56 04 00
parker.denmark@parker.com

ES – Spain, Madrid
Tel: +34 902 330 001
parker.spain@parker.com

FI – Finland, Vantaa
Tel: +358 (0)20 753 2500
parker.finland@parker.com

FR – France, Contamine s/Arve
Tel: +33 (0)4 50 25 80 25
parker.france@parker.com

GR – Greece, Athens
Tel: +30 210 933 6450
parker.greece@parker.com

HU – Hungary, Budapest
Tel: +36 1 220 4155
parker.hungary@parker.com

IE – Ireland, Dublin
Tel: +353 (0)1 466 6370
parker.ireland@parker.com

IT – Italy, Corsico (MI)
Tel: +39 02 45 19 21
parker.italy@parker.com

KZ – Kazakhstan, Almaty
Tel: +7 7272 505 800
parker.easteurope@parker.com

NL – The Netherlands, Oldenzaal
Tel: +31 (0)541 585 000
parker.nl@parker.com

NO – Norway, Asker
Tel: +47 66 75 34 00
parker.norway@parker.com

PL – Poland, Warsaw
Tel: +48 (0)22 573 24 00
parker.poland@parker.com

PT – Portugal, Leca da Palmeira
Tel: +351 22 999 7360
parker.portugal@parker.com

RO – Romania, Bucharest
Tel: +40 21 252 1382
parker.romania@parker.com

RU – Russia, Moscow
Tel: +7 495 645-2156
parker.russia@parker.com

SE – Sweden, Spånga
Tel: +46 (0)8 59 79 50 00
parker.sweden@parker.com

SK – Slovakia, Banská Bystrica
Tel: +421 484 162 252
parker.slovakia@parker.com

SL – Slovenia, Novo Mesto
Tel: +386 7 337 6650
parker.slovenia@parker.com

TR – Turkey, Istanbul
Tel: +90 216 4997081
parker.turkey@parker.com

UA – Ukraine, Kiev
Tel: +380 44 494 2731
parker.ukraine@parker.com

UK – United Kingdom, Warwick
Tel: +44 (0)1926 317 878
parker.uk@parker.com

ZA – South Africa, Kempton Park
Tel: +27 (0)11 961 0700
parker.southafrica@parker.com

North America

CA – Canada, Milton, Ontario
Tel: +1 905 693 3000

US – USA, Cleveland (industrial)
Tel: +1 216 896 3000

US – USA, Elk Grove Village (mobile)
Tel: +1 847 258 6200

Asia Pacific

AU – Australia, Castle Hill
Tel: +61 (0)2-9634 7777

CN – China, Shanghai
Tel: +86 21 2899 5000

HK – Hong Kong
Tel: +852 2428 8008

IN – India, Mumbai
Tel: +91 22 6513 7081-85

JP – Japan, Fujisawa
Tel: +81 (0)4 6635 3050

KR – South Korea, Seoul
Tel: +82 2 559 0400

MY – Malaysia, Shah Alam
Tel: +60 3 7849 0800

NZ – New Zealand, Mt Wellington
Tel: +64 9 574 1744

SG – Singapore
Tel: +65 6887 6300

TH – Thailand, Bangkok
Tel: +662 717 8140

TW – Taiwan, Taipei
Tel: +886 2 2298 8987

South America

AR – Argentina, Buenos Aires
Tel: +54 3327 44 4129

BR – Brazil, Sao Jose dos Campos
Tel: +55 12 4009 3500

CL – Chile, Santiago
Tel: +56 2 623 1216

MX – Mexico, Apodaca
Tel: +52 81 8156 6000

VE – Venezuela, Caracas
Tel: +58 212 238 5422

Ed. 2010-11-16



EMEA Product Information Centre

Free phone: 00 800 27 27 5374

(from AT, BE, CH, CZ, DE, DK, EE, ES, FI, FR, IE, IL, IS, IT, LU, MT, NL, NO, PL, PT, RU, SE, SK, UK, ZA)

US Product Information Centre

Toll-free number: 1-800-27 27 537

www.parker.com

Your local authorized Parker distributor