

Operating instructions Compax3 I12T11

Positioning via digital I/Os & RS232/RS485



192-120113 N3 C3I12T11

Release 2004R3-1 (as from Firmware V2.05)

August 2005

Copyright © 2004 Parker Hannifin GmbH & Co. KG EME
All rights reserved.

Windows NT®, Windows 2000™, Windows XP™ are trademarks of Microsoft Corporation.

EME - Electromechanical Automation Europe

Germany: Parker Hannifin GmbH & Co. KG
Electromechanical Automation
Postfach: 77607-1720
Robert-Bosch-Str. 22
D-77656 Offenburg
Tel.: +49 (0)781 509-0
Fax: +49 (0)781 509-98176



E-Mail: sales.hauser@parker.com <mailto:sales.hauser@parker.com>
Internet: www.parker-eme.com <http://www.parker-eme.com>

England: Parker Hannifin plc
Electromechanical Automation
21 Balena Close
Poole, Dorset England, BH17 /BA UK
Tel.: +44 (0)1202 69 9000
Fax: +44 (0)1202 69 5750

E-mail: sales.digiplan@parker.com <mailto:sales.digiplan@parker.com>
Internet: www.parker-eme.com <http://www.parker-eme.com>

Italy: Parker Hannifin S. p. A
Electromechanical Automation
Via Gounod 1
I-20092 Cinisello Balsamo (MI), Italy
Tel.: +39 (0)266012459
Fax: +39 (0)2660 12808

E-mail: sales.sbc@parker.com <mailto:sales.sbc@parker.com>
Internet: www.parker-eme.com <http://www.parker-eme.com>

EMN - Electromechanical Automation North America

USA: Parker Hannifin Corporation
Electromechanical Automation
5500 Business Park Drive
Rohnert Park, CA 94928
Phone #: (800) 358-9068
FAX #: (707) 584-3715

E-mail: CMR_help@parker.com mailto:CMR_help@parker.com
Internet: www.compumotor.com <http://www.compumotor.com>

Contents

1. Introduction	9
1.1 Device assignment	9
1.2 Type specification plate	10
1.3 Safety Instructions	11
1.3.1. General hazards	11
1.3.2. Safety-conscious working	11
1.3.3. Special safety instructions	12
1.4 Warranty conditions	12
1.5 Conditions of utilization	13
1.5.1. Conditions of utilization for CE-conform operation.....	13
1.5.2. Conditions of utilization for UL permission	15
1.5.3. Current on the mains PE (leakage current).....	16
2. C3I12T11 Function overview	17
3. Compax3 device description.....	19
3.1 Plug and connector assignment Compax3.....	20
3.1.1. Function of the LEDs on the front panel	21
3.1.2. Plug and pin assignment complete	22
3.1.3. Mains voltage supply (plug X1)	24
3.1.3.1 Power supply plug X1 for 1 AC 230VAC/240VAC devices	24
3.1.3.2 Power supply plug X1 for 3AC 230VAC/240VAC devices	24
3.1.3.3 Power supply plug X1 for 3AC 400VAC/480VAC devices	25
3.1.4. Braking resistor / high voltage DC (plug X2).....	26
3.1.4.1 Braking resistor / high voltage supply plug X2 for 1AC 230VAC/240VAC devices.....	26
3.1.4.2 Braking resistor / high voltage supply plug X2 for 3AC 230VAC/240VAC devices.....	26
3.1.4.3 Braking resistor / high voltage supply plug X2 for 3AC 400VAC/480VAC devices.....	27
3.1.4.4 Connection of the power voltage of 2 Compax3 3AC devices	27
3.1.5. Motor / Motor brake (plug X3)	28
3.1.6. Resolver / Feedback (connector X13).....	29
3.1.7. Control voltage 24VDC / enable (plug X4)	30
3.1.8. RS232 / RS485 interface (plug X10)	31
3.1.9. Analog / Encoder (plug X11)	32
3.1.9.1 Wiring of analog interfaces	32
3.1.9.2 Connections of the encoder interface	32
3.1.10. Digital inputs/outputs (plug X12).....	33
3.1.10.1 Connection of the digital Outputs/Inputs	33

3.2	Installation and dimensions Compax3.....	34
3.2.1.	Installation and dimensions of Compax3 S0xx V2	34
3.2.2.	Installation and dimensions Compax3 S100 V2 and S0xx V4	35
3.2.3.	Installation and dimensions Compax3 S150 V2 and S150 V4	36
3.2.4.	Installation and dimensions of Compax3 S300 V4	37
3.3	Safety function – safe standstill -	38
3.3.1.	Safety instructions for the “safe standstill“ function	41
3.3.2.	Application examples for “safe standstill“	42
3.3.2.1	Sample circuit example of Compax3 devices without fieldbus option.....	42
3.3.2.2	Sample circuit example of Compax3 devices with fieldbus option	47
3.3.2.3	Sample circuit for C3 powerPLmC multi-axis application.....	51
4.	Setting up Compax3	55
4.1	Configuration	56
4.1.1.	Selection of the supply voltage used	57
4.1.2.	Motor Selection	58
4.1.3.	Optimize motor reference point and switching frequency of the motor current.....	58
4.1.4.	Braking Resistor.....	61
4.1.5.	General Drive.....	61
4.1.6.	Defining the reference system.....	62
4.1.6.1	Measure reference	62
4.1.6.2	Machine Zero	66
4.1.6.3	Travel Limit Settings.....	82
4.1.6.4	Exchange assignment direction reversal / limit switches	86
4.1.6.5	Change initiator logic.....	86
4.1.7.	Defining jerk / ramps	87
4.1.7.1	Jerk limitation.....	87
4.1.7.2	Ramp upon error / deenergize.....	89
4.1.8.	Monitoring / Limit Settings.....	89
4.1.8.1	Current (Torque) Limit	89
4.1.8.2	Positioning window - Position reached.....	90
4.1.8.3	Following error limit	91
4.1.8.4	Maximum operating speed	92
4.1.9.	Operating mode / I/O assignment.....	93
4.1.9.1	I/O assignment for control via the Compax3 inputs/outputs.....	93
4.1.9.2	I/O assignment, control word and status word with control via RS232 / RS485.....	95
4.1.10.	Encoder Output.....	99
4.1.10.1	Encoder bypass with Feedback module F12 (for direct drives).....	99
4.1.11.	Absolute / Relative positioning.....	99
4.1.12.	Defining the STOP function	100
4.1.13.	Reg-related positioning / defining ignore zone.....	101
4.1.14.	Write into set table	102
4.1.14.1	Programmable status bits (PSBs).....	103
4.1.14.2	Set selection	103
4.1.14.3	MoveAbs and MoveRel	104
4.1.14.4	Reg-related positioning (RegSearch, RegMove).....	105
4.1.14.5	Electronic gearbox (Gearing).....	109
4.1.14.6	Speed specification (Velocity).....	110
4.1.14.7	Stop command (Stop)	110

4.1.15.	Dynamic positioning	111
4.1.16.	RS485 setting values.....	111
4.1.17.	Configuration name / comments	112
4.2	Optimization	113
4.2.1.	Control Loop Dynamics	113
4.2.1.1	Velocity loop stiffness.....	114
4.2.1.2	Velocity loop damping	115
4.2.1.3	Velocity Filter	115
4.2.1.4	Advanced control parameters.....	116
4.2.2.	Input simulation	120
4.2.2.1	Calling up the input simulation.....	120
4.2.2.2	Functionality.....	121
4.2.3.	Calibration of the analog input	121
4.2.3.1	Offset alignment.....	121
4.2.3.2	Gain alignment.....	122
4.2.4.	Commissioning mode	122
4.2.5.	Turning the motor holding brake on and off.....	123
4.3	Select signal source for Gearing	124
4.3.1.	Signal source HEDA.....	125
4.3.2.	Encoder A/B 5V or step/direction as signal source	125
4.3.2.1	Example: Electronic gearbox with position detection via encoder	126
4.3.3.	+/-10V analog speed setpoint value as signal source	127
4.3.3.1	Time frame signal source master.....	127
5.	Control via RS232 / RS485	128
5.1	Status diagram	129
5.2	I/O assignment, control word and status word with control via RS232 / RS485	131
5.2.1.	I/O Assignment.....	132
5.2.2.	Control word.....	133
5.2.3.	status word 1 & 2.....	134
5.3	Examples: Control via RS232 / RS485	135
5.4	Layout of the set table	137
5.5	RS232 & RS485 – interface record	139
5.5.1.	RS485 setting values.....	139
5.5.2.	ASCII - record	140
5.5.3.	Binary record.....	141
5.6	Compax3 - Objects	145
5.6.1.	Object overview I12 T11	145
5.6.2.	I12 T11 object list sorted by object name.....	146
5.6.2.1	I12 T11 Object: Setpoint delay for bus master	147
5.6.2.2	I12 T11 Object: Input word of I/O option	147
5.6.2.3	I12 T11 Object: Output word for I/O option	147
5.6.2.4	I12 T11 Object: Error (n-1) in the error history	147
5.6.2.5	I12 T11 Object: Current master position for Gearing	148
5.6.2.6	I12 T11 Object: Status of actual acceleration unfiltered.....	148
5.6.2.7	I12 T11 Object: Status of filtered actual acceleration	148

5.6.2.8	I12 T11 Object: Status demand acceleration	148
5.6.2.9	I12 T11 Object: Status acceleration feed forward.....	149
5.6.2.10	I12 T11 Object: Status of actual current RMS (torque producing).....	149
5.6.2.11	I12 T11 Object: Status of control deviation of current control RMS....	149
5.6.2.12	I12 T11 Object: Status of current rms and jerk feedforward.....	149
5.6.2.13	I12 T11 Object: Status of current phase U	149
5.6.2.14	I12 T11 Object: Status of current phase V	150
5.6.2.15	I12 T11 Object: Status of setpoint current RMS (torque forming)	150
5.6.2.16	I12 T11 Object: Status of demand jerk setpoint generator.....	150
5.6.2.17	I12 T11 Object: Status of current control control signal	150
5.6.2.18	I12 T11 Object: Status of device load	151
5.6.2.19	I12 T11 Object: Status of long-term motor load.....	151
5.6.2.20	I12 T11 Object: Status of observed disturbance.....	151
5.6.2.21	I12 T11 Object: Status of analog input cosine.....	151
5.6.2.22	I12 T11 Object: Status of analog input sine	152
5.6.2.23	I12 T11 Object: Status of cosine in signal processing	152
5.6.2.24	I12 T11 Object: Status of sine in signal processing	152
5.6.2.25	I12 T11 Object: Status of feedback level	152
5.6.2.26	I12 T11 Object: Status actual position	153
5.6.2.27	I12 T11 Object: Status actual position without absolute reference.....	153
5.6.2.28	I12 T11 Object: Status demand position	153
5.6.2.29	I12 T11 Object: Status demand position without absolute reference	153
5.6.2.30	I12 T11 Object: Status of following error	153
5.6.2.31	I12 T11 Object: Status actual speed unfiltered.....	154
5.6.2.32	I12 T11 Object: Status actual speed filtered	154
5.6.2.33	I12 T11 Object: Status demand speed controller input.....	154
5.6.2.34	I12 T11 Object: Status demand speed of setpoint generator	154
5.6.2.35	I12 T11 Object: Status control deviation of speed	154
5.6.2.36	I12 T11 Object: Status speed feed forward	155
5.6.2.37	I12 T11 Object: Status of motor temperature	155
5.6.2.38	I12 T11 Object: Status of power output stage temperature	155
5.6.2.39	I12 T11 Object: Status of analog input 0.....	155
5.6.2.40	I12 T11 Object: Status of analog input 1	156
5.6.2.41	I12 T11 Object: Status of auxiliary voltage.....	156
5.6.2.42	I12 T11 Object: Status DC bus voltage.....	156
5.6.2.43	I12 T11 Object: CW control word.....	156
5.6.2.44	I12 T11 Object: Status word SW	157
5.6.2.45	I12 T11 Object: Status word 2	157
5.6.2.46	I12 T11 Object: Current error (n)	157
5.6.2.47	I12 T11 Object: End of the ignore zone	157
5.6.2.48	I12 T11 Object: Beginning of the ignore zone	158

6. Status values 159

6.1	Drive	160
6.2	Motor.....	160
6.3	Position.....	161
6.4	Speeds	162
6.5	Superimposed motion	163
6.6	Current	164
6.7	Inputs	165

Parker EME	Device assignment
	General hazards
6.8 Cam	165
6.9 Virtual Master	166
6.10 IEC61131-3.....	167
6.11 Feedback	167
6.12 Gearing	169
7. Error	170
7.1 Error list.....	170
8. Compax3 Accessories	187
8.1 Order code for Compax3.....	187
8.2 Accessories order code	188
8.3 Parker servo motors	191
8.3.1. Direct drives	191
8.3.1.1 Transmitter systems for direct drives	191
8.3.1.2 Linear motors.....	192
8.3.1.3 Torque motors.....	192
8.3.2. Rotary servo motors	193
8.4 Connections to the motor	194
8.4.1. Resolver cable.....	195
8.4.2. SinCos cable.....	196
8.4.3. Overview of motor cables	196
8.4.4. Motor cable with plug.....	197
8.4.5. Motor cable for terminal box.....	198
8.5 EMC measures	199
8.5.1. Mains filter	199
8.5.1.1 Mains filter NFI01/01	199
8.5.1.2 Mains filter NFI01/02	200
8.5.1.3 Mains filter for NFI01/03.....	200
8.5.2. Motor output filter	201
8.5.2.1 Motor output filter MDR01/04.....	201
8.5.2.2 Motor output filter MDR01/01.....	202
8.5.2.3 Motor output filter MDR01/05.....	202
8.5.2.4 Wiring of the motor output filter.....	202
8.6 External ballast resistors	203
8.6.1. BRM8/01braking resistors	204
8.6.2. BRM9/01 braking resistor	204
8.6.3. BRM5/01 braking resistor	204
8.6.4. Braking resistor BRM6/02.....	205
8.6.5. Braking resistor BRM4/0x.....	205
8.7 Operator control module BDM.....	206
8.8 EAM06: Terminal block for inputs and outputs.....	206

8.9	ZBH plug set.....	210
8.10	Interface cable.....	211
8.10.1.	RS232 cable.....	211
8.10.2.	RS485 cable to Pop.....	212
8.10.3.	I/O interface X12.....	213
8.10.4.	Ref X11.....	214
8.10.5.	Encoder coupling of 2 Compax3 axes.....	215
8.10.6.	Encoder cable.....	216
8.11	Input/output option M12.....	217
8.11.1.	Assignment of the X22 connector.....	217
8.11.1.1	Input wiring of digital inputs.....	218
8.11.1.2	Output wiring of digital outputs.....	218
8.12	HEDA (motion bus) - Option M11.....	219
8.13	HEDA (M11) & I/Os (M12) => Option M10.....	220
9.	Technical data.....	221
10.	Index.....	231

1. Introduction

In this chapter you can read about:

Device assignment.....	9
Type specification plate.....	10
Safety Instructions	11
Warranty conditions.....	12
Conditions of utilization.....	13

1.1 Device assignment

This manual applies to the following devices:

- ◆ Compax3 S025 V2 + supplement
- ◆ Compax3 S063 V2 + supplement
- ◆ Compax3 S100 V2 + supplement
- ◆ Compax3 S150 V2 + supplement
- ◆ Compax3 S015 V4 + supplement
- ◆ Compax3 S038 V4 + supplement
- ◆ Compax3 S075 V4 + supplement
- ◆ Compax3 S150 V4 + supplement
- ◆ Compax3 S300 V4 + supplement

With the supplement:

- ◆ F10 (Resolver)
- ◆ F11 (SinCos)
- ◆ F12 (linear and rotary direct drives)
- ◆ I12 T11

1.2 Type specification plate

You will find the exact description of the device on the type specification plate, which is located on the right side of the device:

Compax3 - Type specification plate:

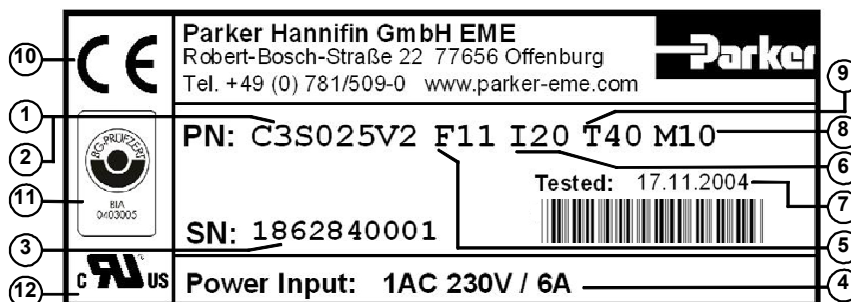

Explanation:

1	Type designation The complete order designation of the device (2, 5, 6, 9, 8)
2	C3S025V2 C3: Abbreviation for Compax3 S: Single axis device with direct AC mains power supply 025: Device current drain in 100mA (025=2.5A) V2: 230VAC/240VAC; V4: 400VAC/480VAC
3	Unique number of the particular device
4	Nominal supply voltage: 1AC = single phase, 3AC = three phase / input current
5	Designation of the feedback system F10: Resolver F11: SinCos [®] / Single- or Multiturn F12: Feedback module for direct drives
6	Device interface I10: Analog, step/direction and encoder input I11 / I12: Digital Inputs / Outputs and RS232 / RS485 I20: Profibus DP I21: CANopen
7	Date of factory test
8	Options
9	Technology function T10: Servo controller T11: Positioning T30: Motion control programmable according to IEC61131-3 T40: Electronic cam generation
10	CE compliance
11	BG - Prüfzert Safe standstill as per EN954-1, category 3
12	UL certification

1.3 Safety Instructions

In this chapter you can read about:

General hazards	11
Safety-conscious working	11
Special safety instructions	12

1.3.1. General hazards

General Hazards on Non-Compliance with the Safety Instructions

The device described in this manual is designed in accordance with the latest technology and is safe in operation. Nevertheless, the device can entail certain hazards if used improperly or for purposes other than those explicitly intended.

Electronic, moving and rotating components can

- ◆ constitute a hazard for body and life of the user, and
- ◆ cause material damage

Usage in accordance with intended purpose

The device is designed for operation in electric power drive systems (VDE0160). Motion sequences can be automated with this device. Several motion sequences can be combined by interconnecting several of these devices. Mutual interlocking functions must be incorporated for this purpose.

1.3.2. Safety-conscious working

This device may be operated only by qualified personnel.

Qualified personnel in the sense of these operating instructions consists of:

- ◆ Persons who, by virtue to their training, experience and instruction, and their knowledge of pertinent norms, specifications, accident prevention regulations and operational relationships, have been authorized by the officer responsible for the safety of the system to perform the required task and in the process are capable of recognizing potential hazards and avoiding them (definition of technical personnel according to VDE105 or IEC364),
- ◆ Persons who have a knowledge of first-aid techniques and the local emergency rescue services.
- ◆ Persons who have read and will observe the safety instructions.
- ◆ Those who have read and observe the manual or help (or the sections pertinent to the work to be carried out).

This applies to all work relating to setting up, commissioning, configuring, programming, modifying the conditions of utilization and operating modes, and to maintenance work.

This manual and the help information must be available close to the device during the performance of all tasks.

1.3.3. Special safety instructions

- ◆ Check the correct association of the device and its documentation.
- ◆ Never detach electrical connections while voltage is applied to them.
- ◆ Safety devices must be provided to prevent human contact with moving or rotating parts.
- ◆ Make sure that the device is operated only when it is in perfect condition.
- ◆ Implement and activate the stipulated safety functions and devices.
- ◆ Operate the device only with the housing closed.
- ◆ Ensure that motors and any linear drives present are mounted securely.
- ◆ Check that all live terminals are secured against contact. Fatal voltage levels of to 750V occur.
- ◆ Attention when performing a configuration download for master-slave couplings (electronic gearbox, cam)
Always switch Compax3 to currentless before starting the configuration download
Master and Slave axis

1.4 Warranty conditions

- ◆ The device must not be opened.
- ◆ Do not make any modifications to the device, except for those described in the manual.
- ◆ Make connections to the inputs, outputs and interfaces only in the manner described in the manual.
- ◆ When installing the device, make sure the heat dissipator receives sufficient air.
- ◆ Attach the devices according to the mounting instructions, using the provided fixing holes. We cannot provide any guarantee for any other mounting methods.

Note on exchange of options

Compax3 options must be exchanged in the factory to ensure hardware and software compatibility.

1.5 Conditions of utilization

1.5.1. Conditions of utilization for CE-conform operation

- Industry and trade -

The EC guidelines for electromagnetic compatibility 89/336/EEC and for electrical operating devices for utilization within certain voltage limits 73/23/EEC are fulfilled when the following boundary conditions are observed:

Operation of the devices only in the condition in which they were delivered, i.e. with all housing panels.

Mains filter: A mains filter is required in the mains input line if the motor cable exceeds a certain length. Filtering can be provided centrally at the plant mains input or separately at the mains input to each device.

Commercial and residential area (limit values of Class A in accordance with EN 61800-3)

The following mains filters are available for independent utilization:

Device: Compax3	Order No.:	Condition:
S0xxV2	NFI01/01	Only for motor lines longer than 10m
S1xxV2, S0xxV4, S150V4	NFI01/02	Only for motor lines longer than 10m
S300V4	NFI01/03	independent of the length of the motor cable

Industrial area (limit values in accordance with EN 61800-3)

Longer motor cable lengths are possible in industrial areas without a mains power filter.

Connection length: Connection between mains filter and device:

unshielded: < 0.5m
shielded < 5m (fully shielded on ground – e.g. ground of control cabinet)

Motor and Feedback cable:

Operation of the devices only with Parker motor and feedback cables (their plugs contain a special full surface area screening).

The following cable lengths are permitted:

Motor cable < 100 m (the cable should not be rolled up!)
A motor output filter is required for motor cables >20m.

- ◆ MDR01/04 (max. 6.3A rated motor current)
- ◆ MDR01/01 (max. 16A rated motor current)
- ◆ MDR01/05 (max. 30A rated motor current)

Shielding connection of the motor cable

The motor cable should be fully screened and connected to the Compax3 housing. We offer a special **shield connecting terminal** as accessory item (see on page 210)

The shield of the motor cable must also be connected with the motor housing. The fixing (via plug or screw in the terminal box) depends on the motor type.

Feedback cable < 100 m

Motors: Operation with standard motors.

Control: Use only with aligned controller (to avoid control loop oscillation).

Grounding: Connect the filter housing and the Compax3 (grounding screw on the underside) to the cabinet frame, making sure that the contact area is adequate and that the connection has low resistance and low inductance.

Never mount the filter housing and the device on paint-coated surfaces!

Cable installation: Signal lines and power lines should be installed as far apart as possible. Signal leads should never pass close to excessive sources of interference (motors, transformers etc.).

Accessories: Make sure to use only the accessories recommended by Parker

Connect all cable shields at both ends, ensuring large contact areas!

Warning:

This is a product in the restricted sales distribution class according to EN 61800-3. In a domestic area this product can cause radio frequency disturbance, in which case the user may be required to implement appropriate remedial measures.

◆ Fuses

In addition to the main fuse, the devices must be equipped with a S 271 K or S 273 K fuse made by ABB.

- ◆ C3S025V2: ABB, nominal 480V 10A, 6kA
- ◆ C3S063V2: ABB, nominal 480V, 16A, 6kA
- ◆ C3S100V2: ABB, nominal 480V, 16A, 6kA
- ◆ C3S150V2: ABB, nominal 480V, 20A, 6kA
- ◆ C3S015V4: ABB, nominal 480V, 6A, 6kA
- ◆ C3S038V4: ABB, nominal 480V, 10A, 6kA
- ◆ C3S075V4: ABB, nominal 480V, 16A, 6kA
- ◆ C3S150V4: ABB, nominal 480V, 20A, 6kA
- ◆ C3S300V4: ABB, nominal 480V, 25A, 6kA

1.5.3. Current on the mains PE (leakage current)

The leakage current (current on the mains PE) is mainly caused by the capacitive resistance between the conductor and the shielding of the motor cable. If a radio interference filter is used, this results in an additional leakage current, as the filter circuit is linked to protective earth by condensers.

The figure of the leakage current depends on the following factors:

- ◆ Length of the motor cable
- ◆ Switching frequency
- ◆ With or without radio interference filter.
- ◆ Shielded or not shielded motor cable
- ◆ Motor grounded or not
- ◆ The leakage current is important with respect to the handling and usage safety of the device.

Please note:

The device must be operated with effective grounding connection, which must comply with the local regulations for high leakage currents (>3.5mA).

The servo amplifier must, because of higher leakage currents, not be operated with an earth leakage circuit breaker.

An earth leakage (FI) circuit breaker (e.g. ABB series F804) installed must not interrupt the circuit in spite of the following conditions:

- ◆ DC component in leakage current (3 phase rectifier bridge).
- ◆ Brief occurrence of pulse-shaped leakage currents when switching on.
- ◆ High levels of leakage current.

2. C3I12T11 Function overview

Positioning via I/Os and RS232 / RS485.

Due to its high functionality, the Positioning version of Compax3 forms an ideal basis for many applications in high-performance motion automation.

Up to 31 motion profiles with the motion functions:

- ◆ Absolute or relative positioning,
- ◆ electronic gearbox,
- ◆ reg-related positioning,
- ◆ speed control
- ◆ Stop - Set

can be created with the help of the PC software.

The positioning is triggered via the parallel interface (digital interfaces; Option M10 or M12 required) or via RS232 / RS485.

The signal inputs reg input, limit switch and machine zero proximity switch lie fixed on Compax3 standard inputs.

As a rule there are 2 possible usages:

Access via Compax3 inputs and outputs

The functions are triggered via the Compax3 inputs (standard and optional inputs). Therefore the input/output option M12 resp. M10 (with HEDA) is required.

The status information is sent out via the digital Compax3 outputs (standard and optional outputs).

Access via RS232 / RS485

The functions are triggered via a control word and also in part “by hardware” via the Compax3 inputs (standard inputs).

The status information is sent out via a status word and also in part via the digital Compax3 outputs (standard).

Here the input/output option M12 / M10 is not required for control.

Compax3 control technology

High-performance control technology and openness for various sender systems are fundamental requirements for a fast and high-quality automation of movement.

Model / standards / auxiliary material

The structure and size of the device are of considerable importance. Powerful electronics is an important feature which made it possible to manufacture the Compax3 so small and compact. All connectors are located on the front of the Compax3.

Internal mains filters permit connection of motor cables up to a certain length without requiring additional measures. EMC compatibility is within the limits set by EN 61800-3, Class A. The Compax3 is CE-conform.

The intuitive user interface familiar from many applications, together with the oscilloscope function, wizards and online help, simplifies making and modifying settings via the PC.

The optional **Operator control module (BDM01/01 (see on page 206))** for Compax3 makes it possible to exchange devices quickly without requiring a PC.

**Configuration**

Configuration is made on a PC using the Compax3 ServoManager. Install the program on your PC and connect the PC with the Compax3X10 via the RS232 interface (**Cable plan** (see on page 211)).

3. Compax3 device description

In this chapter you can read about:

Plug and connector assignment Compax3	20
Installation and dimensions Compax3	34
Safety function – safe standstill -.....	38

3.1 Plug and connector assignment Compax3

In this chapter you can read about:

Function of the LEDs on the front panel	21
Plug and pin assignment complete	22
Mains voltage supply (plug X1)	24
Braking resistor / high voltage DC (plug X2).....	26
Motor / Motor brake (plug X3).....	28
Resolver / Feedback (connector X13).....	29
Control voltage 24VDC / enable (plug X4).....	30
RS232 / RS485 interface (plug X10).....	31
Analog / Encoder (plug X11)	32
Digital inputs/outputs (plug X12)	33

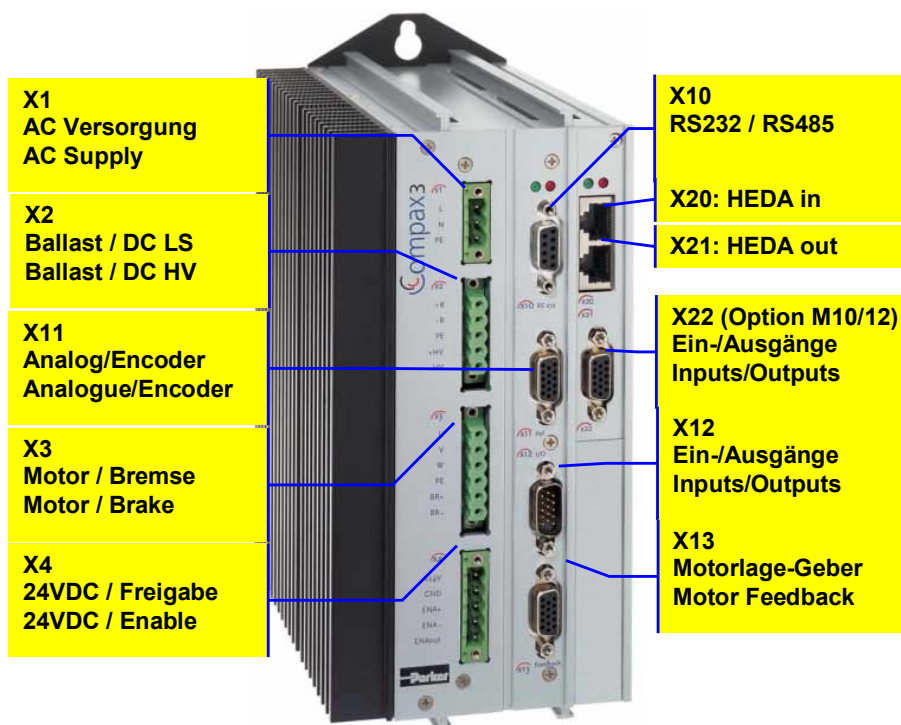

Always switch devices off before wiring them!

Dangerous voltages are still present until 5 minutes after switching off the power supply!



Caution!

When the control voltage is missing there is no indication whether or not high voltage supply is available.

3.1.1. Function of the LEDs on the front panel

State	LED red	LED green
Voltages missing	off	off
While booting	alternately flashing	
No configuration present. SinCos feedback not detected. IEC program not compatible with the firmware. For F12: Hall signals invalid.	flashing	off
Axis without current excitation	off	Flashes slowly
Power supplied to axis; commutation calibration running	off	Flashes quickly
Axis with current excitation	off	on
Axis in fault status / fault present	on	off

3.1.2. Plug and pin assignment complete

The fitting of the different plugs depends on the extension level of Compax3. In part, the assignment depends on the Compax3 option implemented.

Further information on the assignment of the plug mounted at the particular device can be found below!

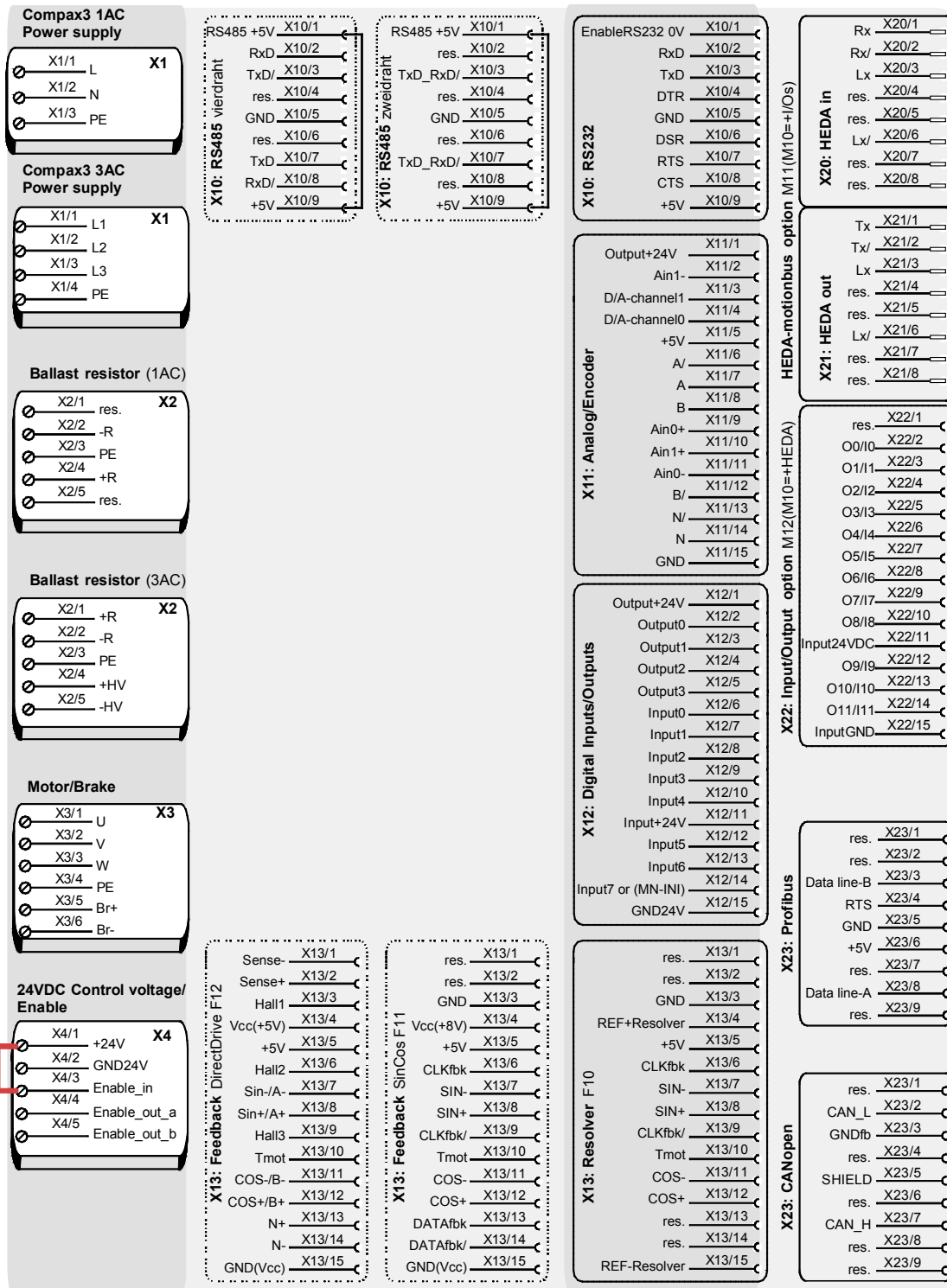

The jumper drawn in at X4 (at the left side in red) is used to enable the device for testing purposes.

During operation, the enable input is in most cases switched externally.

3.1.3. Mains voltage supply (plug X1)

3.1.3.1 Power supply plug X1 for 1 AC 230VAC/240VAC devices

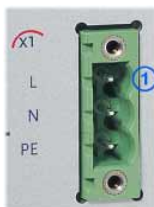

PIN	Designation
1	L
2	N
3	PE

Mains connection for Compax3 S0xx 1AC V2

Controller type	S025 V2	S063 V2
Mains voltage	Single phase 230VAC/240VAC 80-253 VAC/50-60Hz	
Input current	6Aeff	13Aeff
Maximum fuse rating per device	10 A (automatic circuit breaker K)	16 A (automatic circuit breaker K)



Always switch devices off before wiring them!

Dangerous voltages are still present until 5 minutes after switching off the power supply!

3.1.3.2 Power supply plug X1 for 3AC 230VAC/240VAC devices

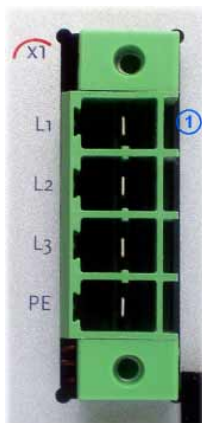

PIN	Designation
1	L1
2	L2
3	L3
4	PE

Mains connection Compax3 S1xx 3AC V2

Controller type	S100 V2	S150 V2
Mains voltage	Three phase 3* 230VAC/240VAC 80-253 VAC/50-60Hz	
Input current	10Aeff	13Aeff
Maximum fuse rating per device	16 A (automatic circuit breaker K)	20 A (automatic circuit breaker K)

Caution!

The 3AC V2 – devices must only be operated with three phases!



Always switch devices off before wiring them!

Dangerous voltages are still present until 5 minutes after switching off the power supply!

3.1.3.3 Power supply plug X1 for 3AC 400VAC/480VAC devices

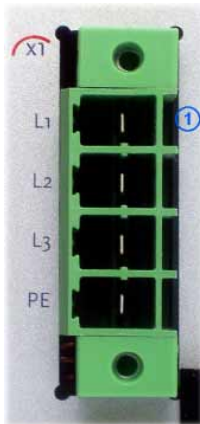

PIN	Designation
1	L1
2	L2
3	L3
4	PE

Mains connection Compax3 Sxxx 3AC V4

Controller type	S015 V4	S038 V4	S075 V4	S150 V4	S300 V4
Mains voltage	Three phase 3*400VAC/480VAC 80-528VAC / 50-60Hz				
Input current	3Aeff	6Aeff	10Aeff	16Aeff	22Aeff
Maximum fuse rating per device	6A	10A	16A	20A	25A
	Automatic circuit breaker K				D*

*for CE-conform operation: Automatic circuit breaker K S273-K.

Caution!

The 3AC V4 – devices must only be operated with three phases!



Always switch devices off before wiring them!

Dangerous voltages are still present until 5 minutes after switching off the power supply!

3.1.4. Braking resistor / high voltage DC (plug X2)

The energy generated during braking operation is absorbed by the Compax3 storage capacity.

If this capacity is too small, the braking energy must be drained via a braking resistor.

3.1.4.1 Braking resistor / high voltage supply plug X2 for 1AC 230VAC/240VAC devices



PIN	Description
1	res.
2	- Braking resistor
3	PE
4	+ Braking resistor
5	res.

Braking operation Compax3 S0xx 1AC V2

Controller type	S025 V2	S063 V2
Capacitance / storable energy	560 μ F / 15Ws	1120 μ F / 30Ws
Minimum ballast - resistance	100 Ω	56 Ω
Recommended nominal power rating	20 ... 60W	60 ... 180W
Pulse power rating for 1s	1kW	2.5kW

Caution!

The power voltage DC of two Compax3 1AC V2 devices (230VAC/240VAC devices) must not be connected.

3.1.4.2 Braking resistor / high voltage supply plug X2 for 3AC 230VAC/240VAC devices

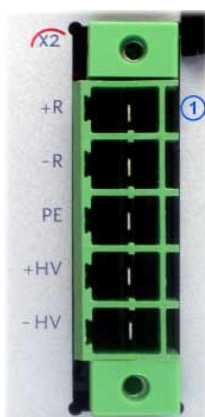

PIN	Description
1	+ Braking resistor
2	- Braking resistor
3	PE
4	+ DC high voltage supply
5	- DC high voltage supply

Braking operation Compax3 S1xx 3AC V2

Controller type	S100 V2	S150 V2
Capacitance / storable energy	780 μ F / 21Ws	1170 μ F / 31Ws
Minimum ballast - resistance	22 Ω	15 Ω
Recommended nominal power rating	60 ... 450W	60 ... 600W
Pulse power rating for 1s	4kW	6kW

3.1.4.3 Braking resistor / high voltage supply plug X2 for 3AC 400VAC/480VAC devices

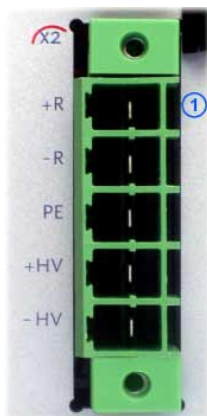

PIN	Description
1	+ Braking resistor
2	- Braking resistor
3	PE
4	+ DC high voltage supply
5	- DC high voltage supply

Brake operation Compax 3 Sxxx 3AC V4

Controller type	S015V4	S038V4	S075V4	S150V4	S300V4
Capacitance / storable energy	235µF / 37Ws	235µF / 37Ws	470µF / 75Ws	690µF / 110Ws	1100µF / 176Ws
Minimum ballast - resistance	100Ω	100Ω	56Ω	22Ω	15Ω
Recommended nominal power rating	60 ... 100W	60 ... 250W	60 ... 500 W	60 ... 1000 W	60 ... 1000 W
Pulse power rating for 1s	1kW	2.5kW	5kW	10 kW	42kW

3.1.4.4 Connection of the power voltage of 2 Compax3 3AC devices

Caution!

The power voltage DC of the single phase Compax3 devices must not be connected!

In order to improve the conditions during brake operation, the DC power voltage of 2 devices may be connected.

The capacity as well as the storable energy are increased; furthermore the braking energy of one device may be utilized by a second device, depending on the application.



It is not permitted to connect the power voltage in order to use one brake chopper for two devices, as this function cannot be ensured reliably.

Please connect as follows:

- Device 1 X2/4 to device 2 X2/4
- Device 1 X2/5 to device 2 X2/5

Please note the following:

Caution! In case of non-compliance with the following instructions, the device may be destroyed!

- ◆ You can only connect two similar devices (same power supply; same rated currents)
- ◆ Connected devices must always be fed separately via the AC power supply.
- ◆ If the external pre-fuse of one of the devices takes action, the second device must also be disconnected automatically.

3.1.5. Motor / Motor brake (plug X3)

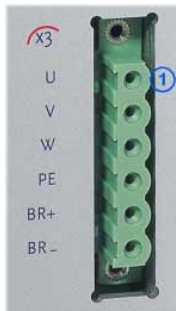

PIN	Designation	
1	U (motor)	
2	V (motor)	
3	W (motor)	
4	PE (motor)	
5	BR+	Motor holding brake
6	BR-	Motor holding brake

Shielding connection of the motor cable

The motor cable should be fully screened and connected to the Compax3 housing. We offer a special **shield connecting terminal** as accessory item (see on page 210)

The shield of the motor cable must also be connected with the motor housing. The fixing (via plug or screw in the terminal box) depends on the motor type.

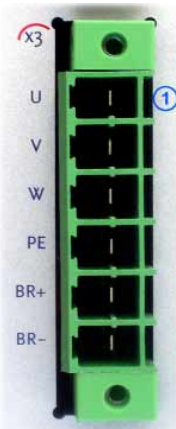

Connect the brake only on motors which have a holding brake! Otherwise make no brake connections at all.

Motor holding brake output

Controller type	Compax3
Voltage range	21 – 27VDC
Maximum output current (short circuit proof)	1.6A

Motor cable (see on page 197)

3.1.6. Resolver / Feedback (connector X13)



PIN X13	Feedback /X13 High Density /Sub D (dependent on the Feedback Module)		
	Resolver (F10)	SinCos (F11)	Direct drives (F12)
1	res.	res.	Sense -
2	res.	res.	Sense +
3	GND	GND	Hall1
4	REF-Resolver+	Vcc (+8V)	Vcc (+5V) (controlled on the encoder side) max. 200mA load
5	+5V (for temperature sensor)		+5V (for temperature and hall sensors)
6	res.	CLKfbk	Hall2
7	SIN-	SIN-	SIN- / A- (Encoder)
8	SIN+	SIN+	SIN+ / A+ (Encoder)
9	res.	CLKfbk/	Hall3
10	Tmot	Tmot	Tmot
11	COS-	COS-	COS- / B- (Encoder)
12	COS+	COS+	COS+ / B+ (Encoder)
13	res.	DATAfbk	N+
14	res.	DATAfbk/	N-
15	REF-Resolver-	GND (Vcc)	GND (Vcc)

Note on F12:

+5V (Pin 4) is measured and controlled directly at the end of the line via Sense – and Sense +.

Maximum cable length: 100m

Caution! Pin 4 and Pin 5 must under no circumstances be connected!

Resolver cables (see on page 195) can be found in the accessories chapter.

SinCos cables (see on page 196) can be found in the accessories chapter.

3.1.7. Control voltage 24VDC / enable (plug X4)

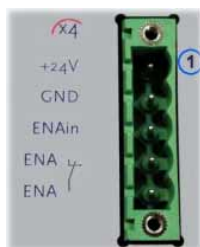

PIN	Description
1	+24V
2	Gnd24 V
3	Enable_in
4	Enable_out_a
5	Enable_out_b

Control voltage 24VDC (X4/1, X4/2)

Controller type	Compax3
Voltage range	21 - 27VDC
Current drain of the device	0.8A
Total current drain	0.8 A + Total load of the digital outputs + current for the motor holding brake
Ripple	0.5Vpp
Requirement according to safe extra low voltage (SELV)	yes

Hardware - enable (input X4/3 = 24VDC)

This input is used as safety interrupt for the power output stage.

Tolerance range: 18.0V - 33.6V / 720Ω

Safe standstill (X4/3=0V)

For implementation of the "Safe standstill" safety feature in accordance with the "protection against unexpected start-up" described in EN1037. Please note the respective **chapter** (see on page 38) with the circuit examples!

The energy supply to the drive is reliably shut off, the motor has no torque.

A relay contact is located between X4/4 and X4/5 (normally closed contact)

Enable_out_a - Enable_out_b	Power output stage is
Contact opened	activated
Contact closed	disabled

Series connection of these contacts permits certain determination of whether all drives are de-energized.

Relay contact data:

Switching voltage (AC/DC): 100mV -60V

Switching current: 10mA - 0.3A

Switching power: 1mW...7W

3.1.8. RS232 / RS485 interface (plug X10)



Interface selectable by contact functions assignment of X10/1:

X10/1=0V RS232

X10/1=5V RS485

RS232

PIN X10	RS232 (Sub D)
1	(Enable RS232) 0V
2	RxD
3	TxD
4	DTR
5	GND
6	DSR
7	RTS
8	CTS
9	+5V

RS485 2-wire

PIN X10	RS485 two wire (Sub D) Pin 1 and 9 jumpered externally
1	Enable RS485 (+5V)
2	res.
3	TxD_RxD/
4	res.
5	GND
6	res.
7	TxD_RxD
8	res.
9	+5V

RS485 4-wire

PIN X10	RS485 four wire (Sub D) Pin 1 and 9 jumpered externally
1	Enable RS485 (+5V)
2	RxD
3	TxD/
4	res.
5	GND
6	res.
7	TxD
8	RxD/
9	+5V

3.1.9. Analog / Encoder (plug X11)



PIN X11	Reference	
	High Density Sub D	
1	+24V (output for encoder) max. 70mA	
2	Ain1 -: analog input - (14Bit; max. +/-10V)	
3	D/A monitor channel 1 ($\pm 10V$, 8-bit resolution)	
4	D/A monitor channel 0 ($\pm 10V$, 8-bit resolution)	
5	+5V (output for encoder) max. 150mA	
6	- Input: steps RS422 (5V - level)	A/ (Encoder- input / -simulation)
7	+ Input: steps RS422 (5V - level)	A (Encoder- input / -simulation)
8	+ Input: direction RS422 (5V - level)	B (Encoder- input / -simulation)
9	Ain0 +: analog input + (14Bit; max. +/-10V)	
10	Ain1 +: analog input + (14Bit; max. +/-10V)	
11	Ain0 -: analog input - (14Bit; max. +/-10V)	
12	- Input: direction RS422 (5V - level)	B/ (Encoder- input / -simulation)
13	reserved	N/ (Encoder simulation)
14	reserved	N (Encoder simulation)
15	GND	

3.1.9.1 Wiring of analog interfaces

Output

Input

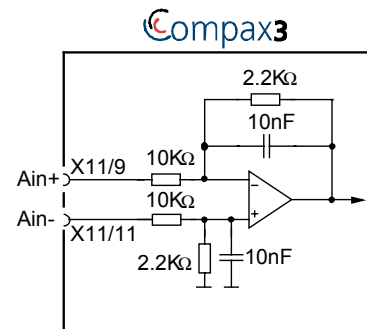
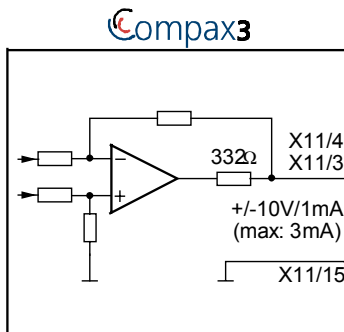

Ain1 (X11/10 and X11/2) has the same wiring!

3.1.9.2 Connections of the encoder interface

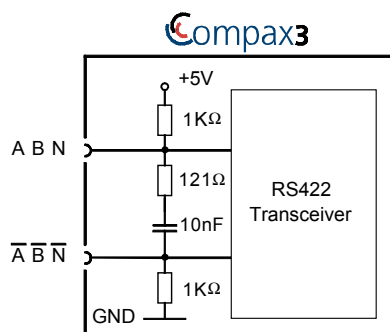

3.1.10. Digital inputs/outputs (plug X12)



PIN X12	Input/output	High density/Sub D
1	O	+24VDC output (max. 400mA)
2	O0	No Error
3	O1	Position / velocity / gear synchronization reached (max. 100mA)
4	O2	No power output stage current (max. 100mA)
5	O3	Motor stationary with current, with setpoint 0 (max. 100mA)
6	I0="1":	Quit (positive edge) / Energize the motor The address of the current motion set is read in new.
	I0="0"	Motor deenergized with delay
7	I1	No stop
8	I2	JOG+
9	I3	JOG -
10	I4	Reg input
11	I	24V input for the digital outputs Pins 2 to 5
12	I5	Limitswitch 1
13	I6	Limitswitch 2
14	I7	Machine reference initiator
15	O	Gnd 24 V

All inputs and outputs have 24V level.

Maximum capacitive loading of the outputs: 50nF (max. 4 Compax3-inputs can be connected)

In operation via RS232 / RS485 the inputs I0 ... I3 as well as the outputs O0 ... O3 can be freely assigned as an option.

Configurable via the C3 ServoManager (configuration: Operating mode / I/O assignment)

3.1.10.1 Connection of the digital Outputs/Inputs

Wiring of digital outputs

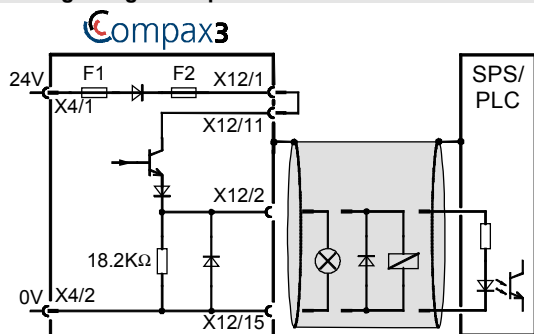

Wiring of digital inputs

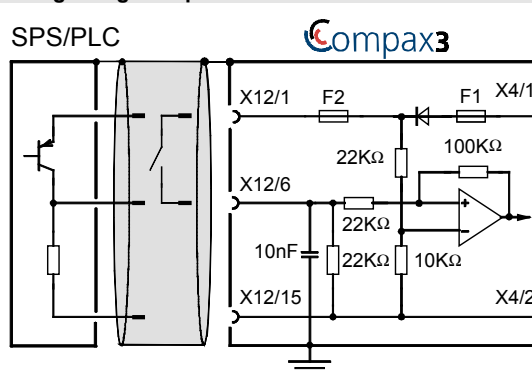

The circuit example is valid for all digital outputs!

The outputs are short circuit proof; a short circuit generates an error.

F1: delayed action fuse

F2: quick action electronic fuse; can be reset by switching the 24VDC supply off and on again.

The circuit example is valid for all digital inputs!

3.2 Installation and dimensions Compax3

In this chapter you can read about:

Installation and dimensions of Compax3 S0xx V2	34
Installation and dimensions Compax3 S100 V2 and S0xx V4	35
Installation and dimensions Compax3 S150 V2 and S150 V4	36
Installation and dimensions of Compax3 S300 V4	37

3.2.1. Installation and dimensions of Compax3 S0xx V2

Mounting:

3 socket head screws M5

Mounting spacing:

Device separation 15 mm

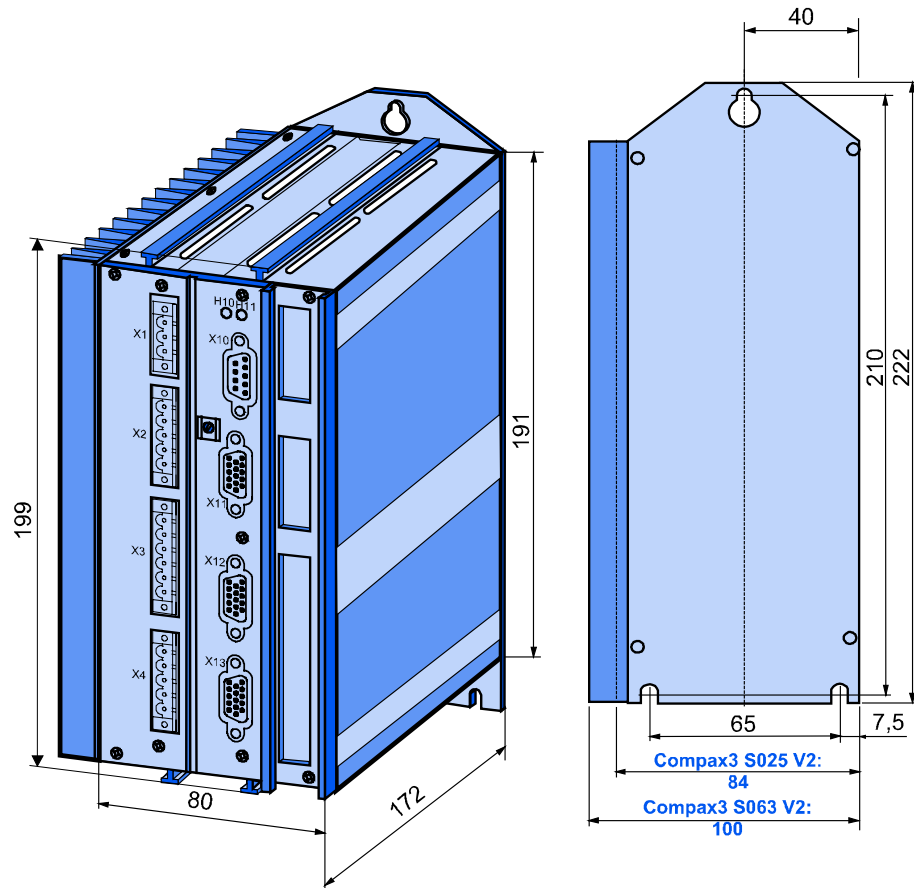

3.2.2. Installation and dimensions Compax3 S100 V2 and S0xx V4

Mounting:

3 socket head screws M5

Mounting spacing:

Device separation 15 mm

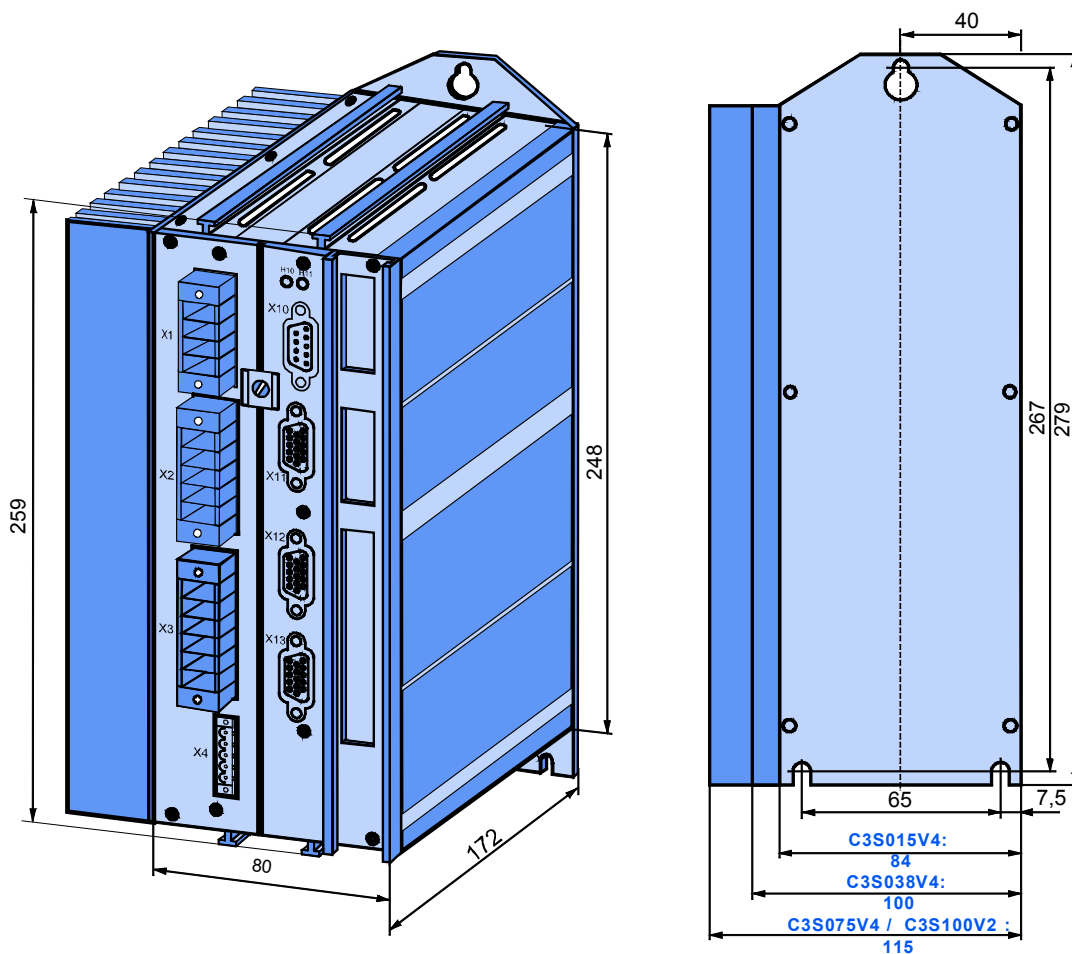

3.2.3. Installation and dimensions Compax3 S150 V2 and S150 V4

Mounting:

4 socket head screws M5

Mounting spacing:

Device separation 15 mm

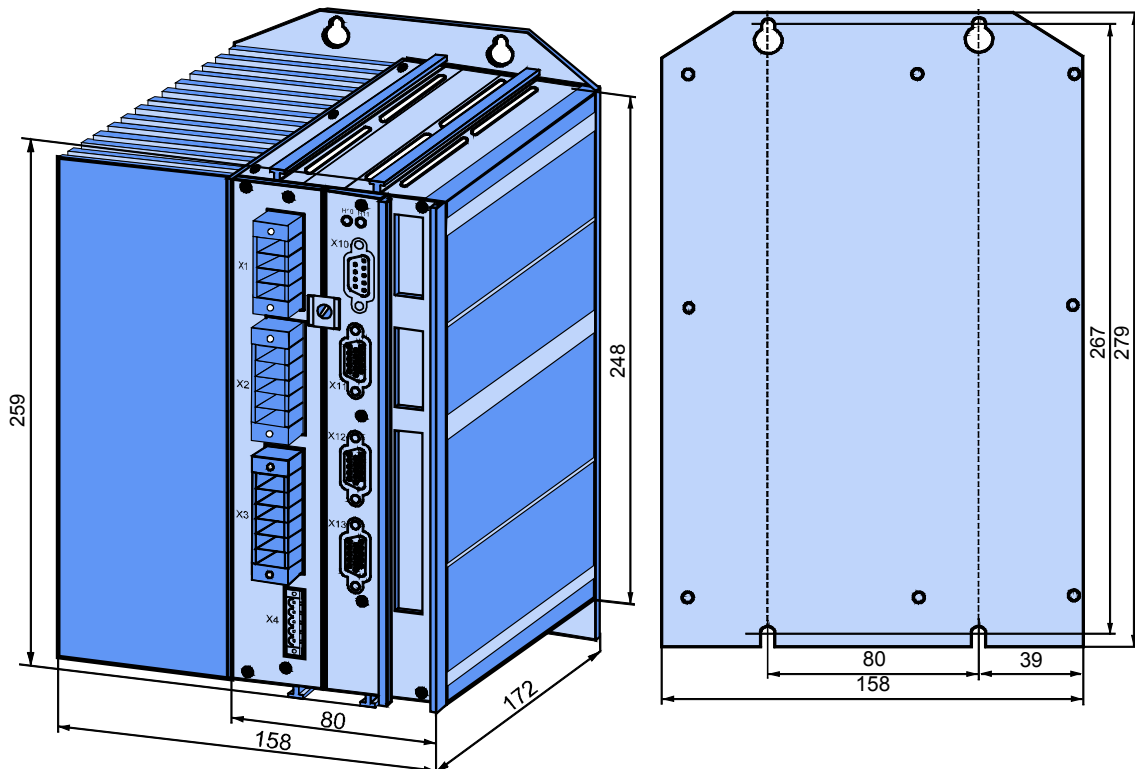

3.2.4. Installation and dimensions of Compax3 S300 V4

Mounting:

4 socket head screws M5

Mounting spacing:

Device separation 15 mm

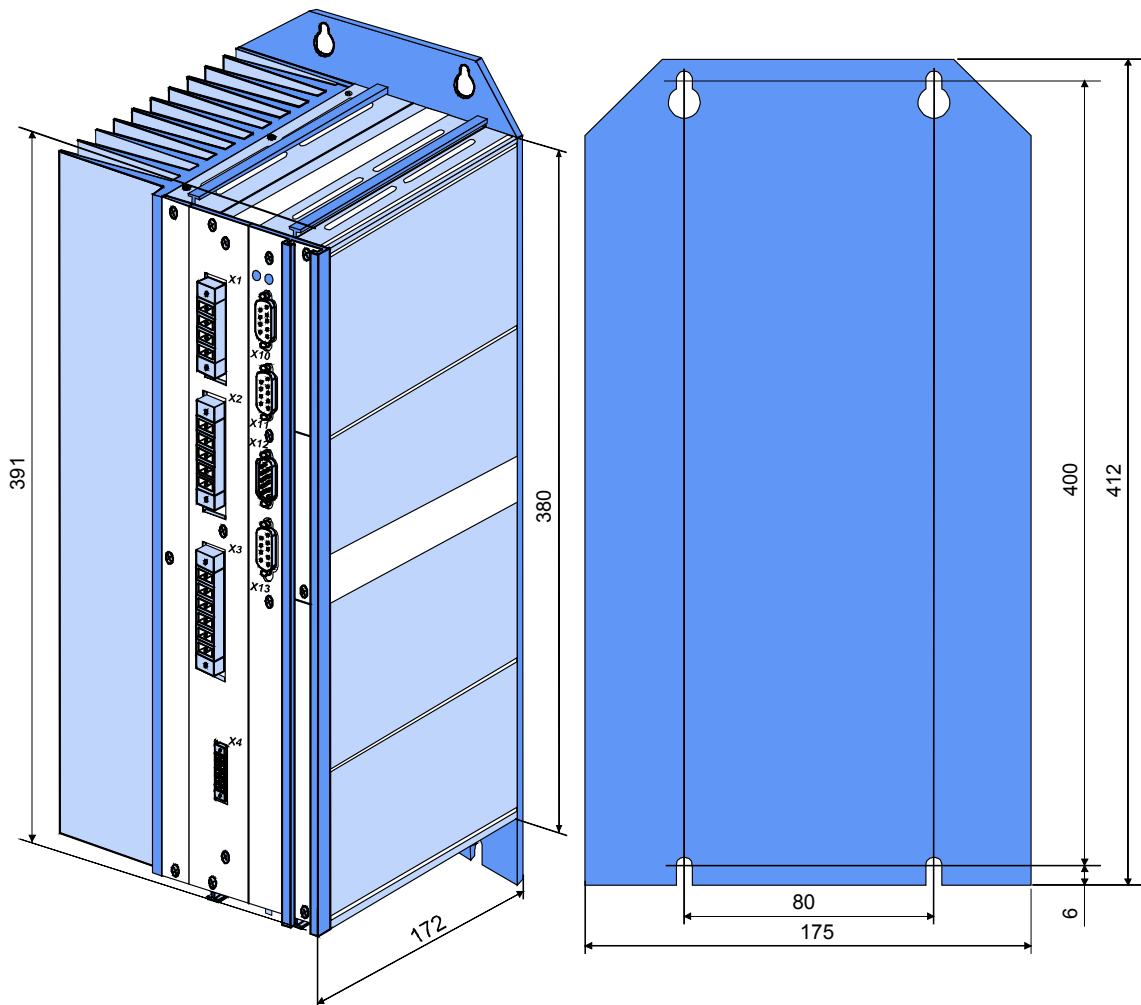

Compax3 S300 V4 is force-ventilated via a fan integrated into the heat dissipator!

3.3 Safety function – safe standstill -

In this chapter you can read about:

Safety instructions for the "safe standstill" function	41
Application examples for "safe standstill"	42

Compax3 is equipped with the "Safe Standstill" safety feature.

The "protection against unexpected start-up" described in EN1037 can be implemented with this feature.

Principle:

To ensure safe protection against a motor starting up unexpectedly, the flow of current to the motor and thus to the power output stage must be prevented.

This is accomplished for Compax3 with two measures independent of each other (Channel 1 and 2), without disconnecting the drive from the power supply:

Channel 1:

Activation of the power output stage can be disabled in the Compax3 controller by means of a digital input or with a fieldbus interface (depending on the Compax3 device type) (deactivation of the energize input).

Channel 2:

The power supply for optocouplers and drivers of power output stage signals is disconnected by a safety relay activated by the "ENABLE" (X4/3) input and equipped with force-directed contacts. This prevents control signals from being transferred to the power output stage.



The „Safe Standstill“ safety function as defined by EN 954-1 Category 3 is only possible if both channels are used.

Circuit diagram illustrating working principle:

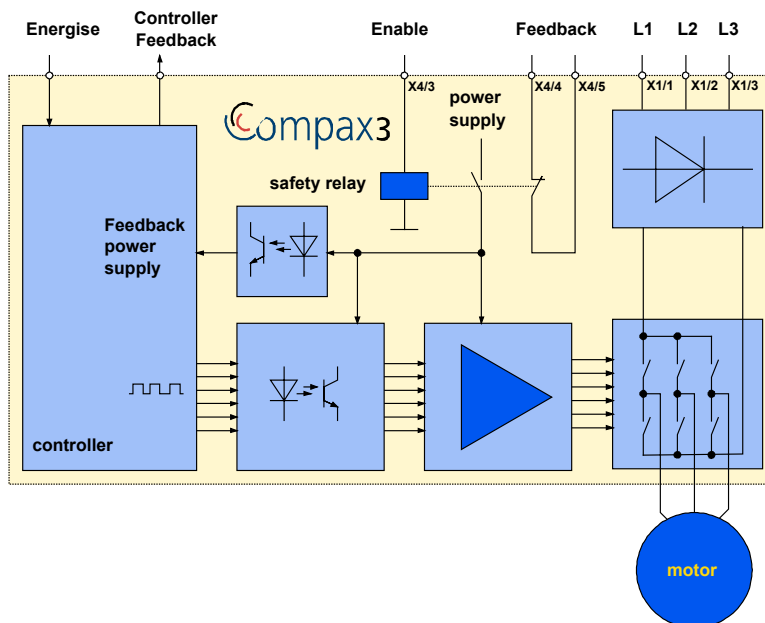

Notes

- ◆ In normal operation of Compax3, 24 V DC of power is supplied to the "Enable" input (X4/3). The drive is then controlled by the digital inputs/outputs or the fieldbus.
- ◆ When used properly, the "Safe standstill" safety function is only used when the motor is at a standstill, since it is not capable of braking a motor or bringing it to a standstill by itself.

The "Safe Standstill" safety function is implemented in the following devices:

Compax3 technology function	Device power
◆ I10T10	◆ S025V2
◆ I11T11	◆ S063V2
◆ IxxT30	◆ S100V2
◆ IxxT40	◆ S150V2
◆ I12T11	◆ S015V4
◆ I20T11	◆ S038V4
◆ I21T11	◆ S075V4
◆ C10T11	◆ S150V4
	◆ S300V4

Compax3-specific Inputs and Outputs channel 1

The "Energize" input and the "Controller Feedback" output depend on the Compax3 device type:

- ◆ Compax3 I10 T10, I11 T11, C10T11: a permanently assigned digital input and output (see in the application examples).
- ◆ Compax3 I12 T11: a permanently assigned digital input and output (see in the application examples), or realize the "energize" function via the RS485 – bus interface (programmable in the Compax3).
- ◆ Compax3 T30 / T40: "Energize" and "Controller Feedback" are applied to the I/Os by way of the IEC program.
- ◆ Compax3 with fieldbus: "Energize" and "Controller Feedback" are activated or queried by the bus (via control and status word).

3.3.1. Safety instructions for the “safe standstill“ function

- ◆ Safety functions must be tested 100%.
- ◆ Only qualified staff members are permitted to install the „Safe Standstill“ feature and place it in service.
- ◆ For all applications in which the first channel of the „Safe Standstill“ is implemented by means of a PLC, care must be taken that the part of the program that is responsible for current flowing to or not flowing to the drive is programmed with the greatest possible care. The „Safe Standstill“ application example of Compax3 with fieldbus should be considered.
The designer and operator responsible for the system and machine must refer programmers who are involved to these safety-related points.
- ◆ Terminal X4/2 (GND 24 V and at the same time the reference point for the safety relay bobbin) must be connected with the PE protective lead. This is the only way to ensure protection against incorrect operation through earth faults (EN60204-1 Section 9.4.3)!
- ◆ All conditions necessary for **CE-conform operation** (see on page 13) must be observed.
- ◆ It should be noted in connection with the „Safe Standstill“ application example illustrated here that after the Emergency Power-off switch has been activated, no galvanic isolation in accordance with EN 60204-1 Section 5.5 is guaranteed. This means that the entire system must be disconnected from the mains power supply with an additional main switch or mains power contactor for an “Emergency Power-off” (for example for repair jobs). Please note in this regard that even after the power is disconnected, dangerous electrical voltages may still be present in the Compax3 drive for about 5 minutes.
- ◆ When using an external Emergency Stop module with adjustable delay time, (as illustrated in the „Safe Standstill“ application example), it must be ensured that the delay time cannot be adjusted by persons not authorized to do so (for example by applying a lead seal).
The adjustable delay time on the Emergency Power-off module must be set to a value greater than the duration of the braking ramp controlled by the Compax3 with maximum load and maximum speed.
If the setting range for the specified Emergency power-off module is not sufficient, the Emergency power-off module must be replaced by another comparable module.
- ◆ All safety-related external leads (for example the control lead for the safety relay and feedback contact) must absolutely be laid so they are protected, for example in a cable duct. Short circuits and crossed wires must be reliably excluded!
- ◆ If there are external forces operating on the drive axes, additional measures are required (for example additional brakes). Please note in particular the effects of gravity on suspended loads!
- ◆ If the power fails, the possibility must be considered that for the application with stop category K1, such as is described in the application example, it will no longer be possible to execute the braking ramp controlled to speed 0.
- ◆ It is important to note that if the drive is being activated (Energize) by the RS232 (RS485) interface, it may not be possible to execute switch-off by a controlled braking ramp. For example, this is true when the set-up window of the C3 ServoManager is used. If set-up mode is turned on, the digital I/O interface and fieldbus interface are automatically disabled.

3.3.2. Application examples for “safe standstill“

In this chapter you can read about:

Sample circuit example of Compax3 devices without fieldbus option	42
Sample circuit example of Compax3 devices with fieldbus option.....	47
Sample circuit for C3 powerPLmC multi-axis application.....	51

The application examples described here correspond to Stop Category 1 as defined by EN60204-1.

A Stop Category 0 in accordance with EN 60204-1 can be implemented, for example by setting the delay time on the Emergency power-off switch to 0. The Compax3 drive will then be turned off immediately in 2 channels and will not be able to generate any more torque. Please take into consideration that the motor will not brake and a coasting down of the motor may result in hazards. If this is the case, a “Safe Standstill” in the stop category 0 is not permitted.

3.3.2.1 Sample circuit example of Compax3 devices without fieldbus option

Sample circuit for the following Compax3 devices:

Compax3 I10 T10

- ◆ "Energize" input: I0: X12/6
- ◆ "Controller Feedback" output: O2: X12/4



The Stop Category 1 described here cannot be used in the „Torque Controller“ operating mode.

At least Firmware Version V02.01.12 is required to be able to implement the application described here for the Compax3 I10T10 device (the Firmware Version of Compax3 can be seen with the C3 ServoManager under "Online Device Identification").

Compax3 I12 T11:

- ◆ "Energize" input: I2: X12/6
- ◆ "Controller Feedback" output: O2: X12/4

or

- ◆ The “Energize” function (channel 1) can be implemented via the RS485 bus interface (X10) via a corresponding programming of the Compax3. If, in this case, the motor current is to be disabled via channel 1, the Bit0 of the DeviceControl (Control word_1) must be set to “LOW” via the RS485 bus interface.

Compax3 I11 T11:

- ◆ "Energize" input: I2: X12/8
- ◆ "Controller Feedback" output: O2: X12/4

Compax3 Ixx T30 and Compax3 Ixx T40:

- ◆ "Energize" input: Apply the Enable input of the MC_Power module (IEC program) to a Compax3 input.
- ◆ "Controller Feedback" output: Apply the Status output of the MC_Power module (IEC program) to a Compax3 output.



If the Compax3 „Safe Standstill“ feature is required or used for a system or machine, the two error messages „Motor Stalled“ and „Tracking“ must not be turned off for a programmable Compax3 drive (T30, T40) with the „C3 Errormask“ function module.

Structure of Compax3 devices without fieldbus option:

- ◆ 2 Compax3 devices (the circuit example is also valid for one or multiple devices, if it is adapted accordingly)
- ◆ 1 Emergency Power-off module (BH5928.47 manufactured by Dold)
- ◆ 1 safety door monitor (BD5985N made by Dold)
Note: With safety door monitor BD5985N, the safety door must be opened and closed again every time after turning on the 24 V power supply so that the Emergency power-off module can be acknowledged and reset. To avoid this, safety door monitors with an additional simulation entry can also be used.
- ◆ 1 relay per Compax3
- ◆ 1 Emergency power-off switch
- ◆ Hazardous area accessible via a safety door with safety door switch S1 and S2
- ◆ 3 buttons (S3, ... S5)

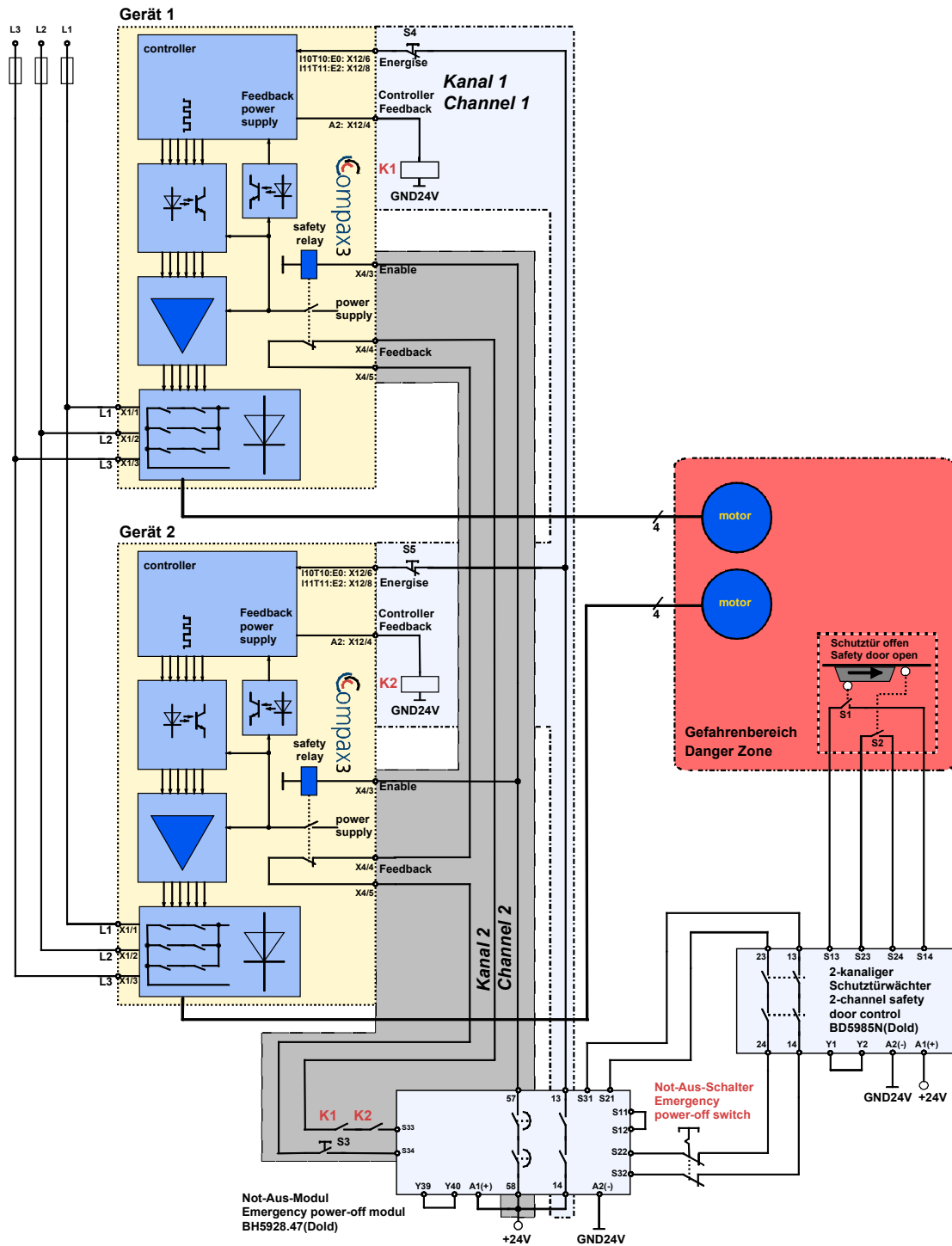

Switches and buttons:

S1:	Closed when the safety door is closed
S2:	Closed when the safety door is closed
S3:	Activate Emergency power-off module
S4:	Guide Device 1 to a currentless state (error acknowledge)
S5:	Guide Device 2 to a currentless state (error acknowledge)

Basic functions:**Compax3 devices disabled by:**

Channel 1: Energize input to "0" through open contacts of Emergency power-off module (13 -14)

Channel 2: Enable input to "0" through open contacts of Emergency power-off module (57 -58)

Activate Emergency power-off module

Before the Compax3 can be placed in operation, the Emergency power-off module must be activated by a pulse to Input S33/S34.

Prerequisite:

- ◆ S3 closed
- ◆ Safety door closed: only in this case the safety door monitor enables the emergency power off module via two channels.
- ◆ K1 and K2 energized
 - ◆ K1: receives current if Compax3 Device 1 is currentless (output = "1" in currentless state) = Channel 1 feedback
 - ◆ K2: receives current if Compax3 Device 2 is currentless (output = "1" in currentless state) = Channel 1 feedback
- ◆ The feedback contact of all Compax3 devices must be closed (channel 2).

If S33 and S34 of the Emergency power-off module are briefly connected (pulse) the contacts will be closed (between 13 and 14 and between 57 and 58)

Energize Compax3 (Motor and power output stage)

- ◆ Compax3 devices are enabled by the Energize input and the Enable input via the Emergency power-off module. (If an error is still pending on Compax3, it must previously be reset. The acknowledge/reset function depends on the type of the Compax3 device).
- ◆ The motors are energized with current.

Summary: Compax3 is only energized if the feedback functions are capable of functioning via two channels.

Access to the hazardous area**Activate Emergency power-off switch**

The two-channel disconnecting at the emergency power-off switch deactivates the emergency power-off module – the contacts 13 – 14 will open immediately.

Channel 1: Compax3 devices receive the command via the Energize input to guide the drive to a currentless state (using the ramp configured in the C3 ServoManager for "drive disable").

Channel 1 feedback: The "Controller Feedback" Compax3 outputs supply current to Relays K1 and K2.

Channel 2: After the delay time set in the Emergency power-off module, (this time must be set so that all drives are stopped after it has elapsed) the contacts between 57 and 58 open, which in turn deactivates the Enable inputs of the Compax3 devices.

Channel 2 feedback: Via the series circuit of all feedback contacts, the "Safe Standstill" status (all Compax3 devices without current) is reported.

Only if the drives are all at a standstill, the safety door may be opened and the hazardous area may be accessed.

If the safety door is opened during operation and the emergency-power-off switch was not triggered before, the Compax3 drives will also trigger the stop ramp.



Caution! The drives may still move.

If danger to life and limb of a person entering cannot be excluded, the machine must be protected by additional measures (e.g. a safety door locking).

3.3.2.2 Sample circuit example of Compax3 devices with fieldbus option

Sample circuit for the following Compax3 devices:

Compax3 I20 T11

Compax3 I20 T11

Layout:

- ◆ 2 Compax3 devices (the circuit example is also valid for one or multiple devices, if it is adapted accordingly)
- ◆ 1 Emergency Power-off module (BH5928.47 manufactured by Dold)
- ◆ 1 safety door monitor (BD5985N made by Dold)
Note: With safety door monitor BD5985N, the safety door must be opened and closed again every time after turning on the 24 V power supply so that the Emergency power-off module can be acknowledged and reset. To avoid this, safety door monitors with an additional simulation entry can also be used.
- ◆ 1 Relay (K1)
- ◆ 1 Emergency power-off switch
- ◆ Hazardous area accessible via a safety door with safety door switch S1 and S2
- ◆ 1 button (S3)

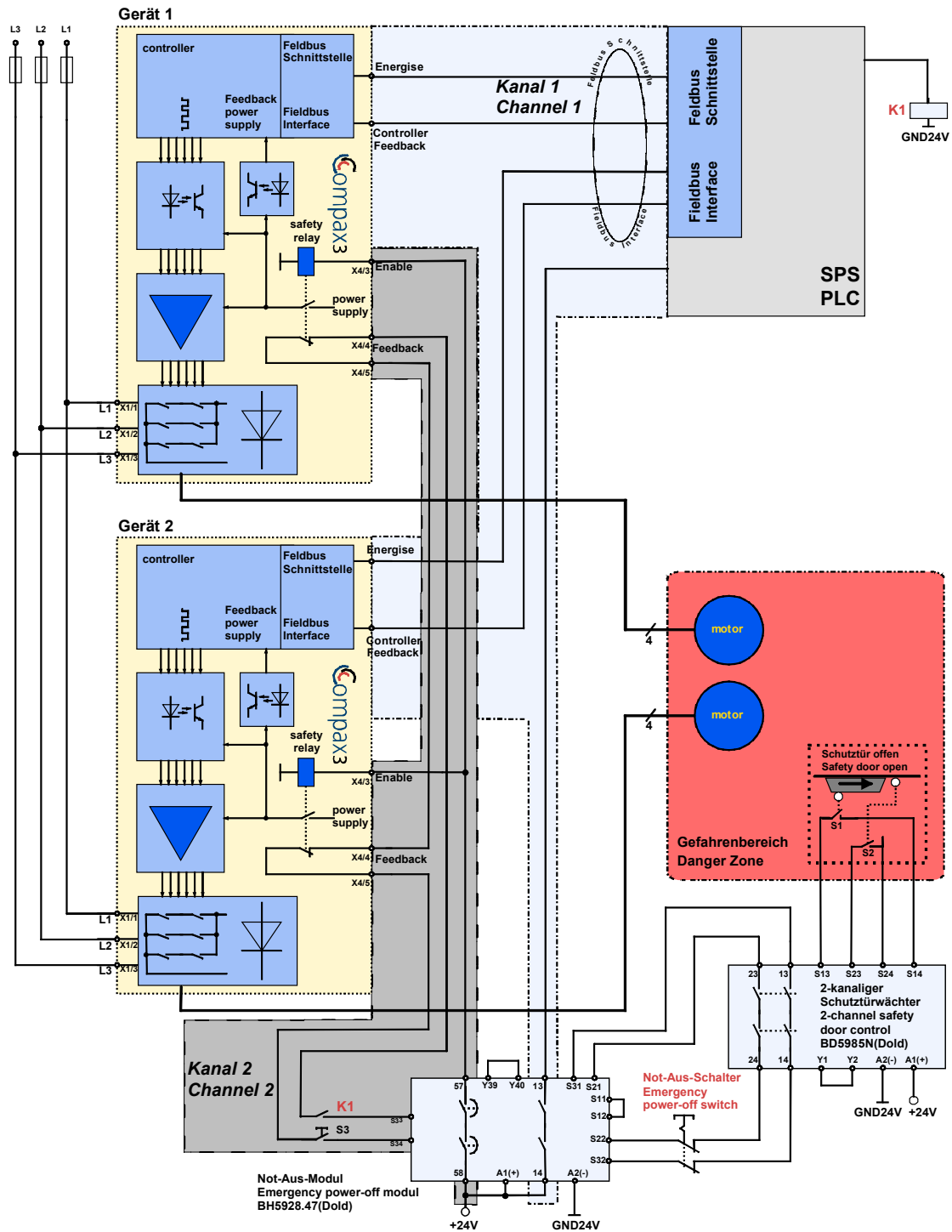

Switches and buttons:

S1:	Closed when the safety door is closed
S2:	Closed when the safety door is closed
S3:	Activate Emergency power-off module

Basic functions:**Compax3 devices disabled by:**

Channel 1: Energize deactivated by PLC due to open contacts of the Emergency power-off module (13 -14)

Channel 2: Enable input to "0" through open contacts of Emergency power-off module (57 -58)

Activate Emergency power-off module

Before the Compax3 can be placed in operation, the Emergency Power-off module must be activated by a pulse to Input S33/S34.

Prerequisite:

- ◆ S3 closed
- ◆ Safety door closed: only in this case the safety door monitor enables the emergency power off module via two channels
- ◆ K1 energized via PLC
- ◆ The feedback contact of all Compax3 devices must be closed (channel 2).

If S33 and S34 of the Emergency power-off module are briefly connected (pulse) the contacts will be closed (between 13 and 14 and between 57 and 58).

Energize Compax3 (Motor and power output stage)

- ◆ The PLC enables the Compax3 devices by means of the control word and the Emergency power-off module enables the Compax3 devices by means of the Enable input. (if an error is still pending on Compax3, it must be previously acknowledged/reset)
- ◆ The motors are energized with current.

Summary: Compax3 is only energized if the feedback functions are capable of functioning via two channels.

Access to the hazardous area

Activate Emergency power-off switch

The two-channel disconnecting at the emergency power-off switch deactivates the emergency power-off module – the contacts 13 – 14 will open immediately.

The PLC evaluates this and responds as follows:

Channel 1: Compax3 devices receive the command via the **control word**¹ to guide the drive to a currentless state (using the ramp configured in the C3 ServoManager for "drive disable").

Channel 1 feedback: The Compax3 feedback via the **status word**² is evaluated by the PLC and passed on to the emergency power-off module via K1.

Channel 2: After the delay time set in the Emergency power-off module, (this time must be set so that all drives are stopped after it has elapsed) the contacts between 57 and 58 open, which in turn deactivates the Enable inputs of the Compax3 devices.

Channel 2 feedback: Via the series circuit of all feedback contacts, the "Safe Standstill" status (all Compax3 devices without current) is reported.

Only if the drives are all at a standstill, the safety door may be opened and the hazardous area may be accessed.

If the safety door is opened during operation and the emergency-power-off switch was not triggered before, the Compax3 drives will also trigger the stop ramp.



Caution! The drives may still move.

If danger to life and limb of a person entering cannot be excluded, the machine must be protected by additional measures (e.g. a safety door locking).

¹ Example of assigning the control word (CW) to guide the drive to a stop and Switch:Profibus: CW.2 = "0" (OUT3) standstill via ramp (FSTOP3) and then currentless-switch.CANopen: CW.3 = "0" Standstill via STOP ramp, then with CW.0 currentless-switch.

² Example of assigning the status word (SW) to guide the drive to a standstill and Switch:Profibus: SW.6 = "1" switch-on disable (motor currentless).CANopen: SW.1 = "0" Ready to Switch on (motor currentless).

3.3.2.3 Sample circuit for C3 powerPLmC multi-axis application



If the Compax3 “Safe Standstill” feature is required or used for a system or machine, the two error messages “Motor Stalled” and “Tracking” (following error) must not be turned off with the “C3 Errormask” function module.

Layout:

- ◆ 1 Compax3 with powerPLmC
- ◆ n Compax3 devices
- ◆ 1 Emergency Power-off module (BH5928.47 manufactured by Dold)
- ◆ 1 safety door monitor (BD5985N made by Dold)
 Note: With safety door monitor BD5985N, the safety door must be opened and closed again every time after turning on the 24 V power supply so that the Emergency power-off module can be acknowledged and reset. To avoid this, safety door monitors with an additional simulation entry can also be used.
- ◆ 1 Relay (K1)
- ◆ 1 Emergency power-off switch
- ◆ Hazardous area accessible via a safety door with safety door switch S1 and S2
- ◆ 1 button S3

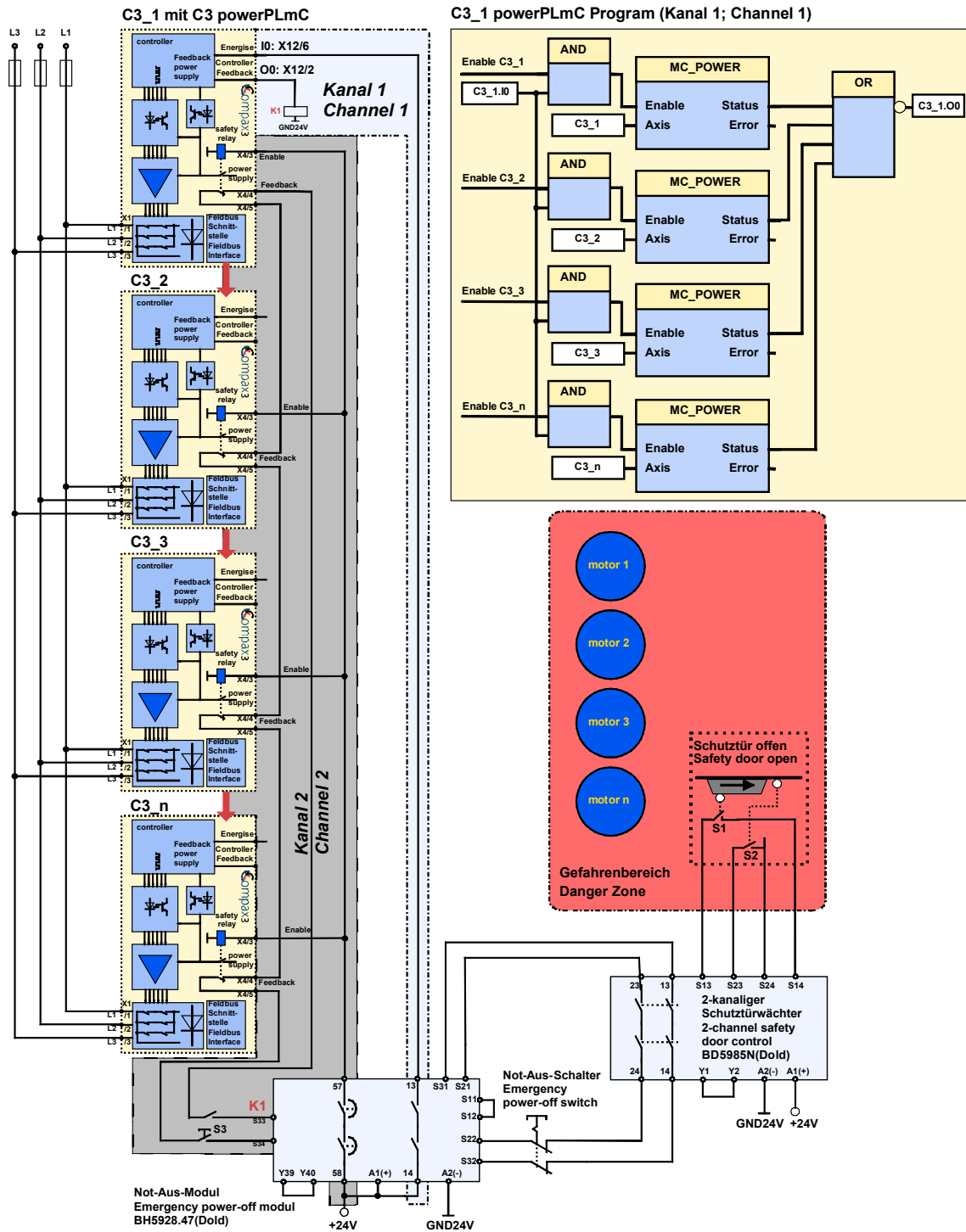

Switches and buttons:

S1:	Closed when the safety door is closed
S2:	Closed when the safety door is closed
S3:	Activate Emergency power-off module

Basic functions:

Compax3 devices disabled by:

Channel 1: Energize input (I0) to C3_1 (with powerPLmC) to "0" through open contacts of Emergency power-off module (13 -14)

Channel 2: Enable inputs of individual Compax3's to "0" through open contacts of Emergency power-off module (57 -58)

Activate Emergency power-off module

Before the Compax3 can be placed in operation, the Emergency power-off module must be activated by a pulse to Input S33/S34.

Prerequisite:

- ◆ S3 closed
- ◆ Safety door closed: only in this case the safety door monitor enables the emergency power off module via two channels.
- ◆ K1 energized
 - ◆ K1: receives current if all Compax3 devices are currentless (Output O0 = "1" if the MC_POWER components of all devices have the status "FALSE".) = Channel 1 feedback
- ◆ The feedback contact of all Compax3 devices must be closed (channel 2).

If S33 and S34 of the Emergency power-off module are briefly connected (pulse) the contacts will be closed (between 13 and 14 and between 57 and 58)

Energize Compax3 (Motor and power output stage)

- ◆ The Enable input is activated on all Compax3's by the Emergency power-off module.
- ◆ Input I0 is also activated (= "1") on Compax3 C3_1, which makes it possible to activate the ENABLE inputs of the MC_Power modules with the AND modules. (If a fault is still pending on Compax3, it must previously be reset. The acknowledge/reset function depends on the type of the Compax3 device).
- ◆ The motors are energized with current.

Summary: Compax3 is only energized if the feedback functions are capable of functioning via two channels.

Access to the hazardous area

Activate Emergency power-off switch

The two-channel disconnecting at the emergency power-off switch deactivates the emergency power-off module – the contacts 13 – 14 will open immediately.

Channel 1: The MC_POWER modules are deactivated for all Compax3's by Input I0 = "0" on device C3_1 (with powerPLmC) via the AND modules. Compax3 devices are guided to a standstill and the current is switched off (by means of the ramp for "drive disable) configured in the C3 ServoManager.

Channel 1 feedback: Output O0 = "1" if the MC_POWER components of all devices have the status "FALSE".

Channel 2: After the delay time set in the Emergency power-off module, (this time must be set so that all drives are stopped after it has elapsed) the contacts between 57 and 58 open, which in turn deactivates the Enable inputs of the Compax3 devices.

Channel 2 feedback: Via the series circuit of all feedback contacts, the "Safe Standstill" status (all Compax3 devices without current) is reported.

Only if the drives are all at a standstill, the safety door may be opened and the hazardous area may be accessed.

If the safety door is opened during operation and the emergency-power-off switch was not triggered before, the Compax3 drives will also trigger the stop ramp.



Caution! The drives may still move.

If danger to life and limb of a person entering cannot be excluded, the machine must be protected by additional measures (e.g. a safety door locking).

4. Setting up Compax3

In this chapter you can read about:

Configuration	56
Optimization	113
Select signal source for Gearing	124

4.1 Configuration

In this chapter you can read about:

Selection of the supply voltage used.....	57
Motor Selection	58
Optimize motor reference point and switching frequency of the motor current.....	58
Braking Resistor.....	61
General Drive.....	61
Defining the reference system.....	62
Defining jerk / ramps.....	87
Monitoring / Limit Settings	89
Operating mode / I/O assignment	93
Encoder Output.....	99
Absolute / Relative positioning	99
Defining the STOP function.....	100
Reg-related positioning / defining ignore zone	101
Write into set table.....	102
Dynamic positioning.....	111
RS485 setting values.....	111
Configuration name / comments	112



Caution!

De-energize the motor before downloading the configuration software.

N.B.!

Incorrect configuration settings entail danger when energizing the motor. Therefore take special safety precautions to protect the travel range of the system.



Mechanical limit values!

Observe the limit values of the mechanical components!

Ignoring the limit values can lead to destruction of the mechanical components.

Configuration sequence:**Installation of the C3 ServoManager**

The Compax3 ServoManager can be installed directly from the Compax3 CD. Click on the appropriate hyperlink or start the installation program "C3Mgr_Setup_V.... .exe" and follow the instructions.

Minimum requirements

For successful installation, your PC must meet the following minimum requirements:

- ◆ Windows NT 4.0 (Intel) with Service Pack 6, Windows 2000 (Service Pack 4 recommended) or Windows XP.
- ◆ Administrator authorisation* on the system
- ◆ Microsoft Internet Explorer 4.01 (SP2) or higher
- ◆ Pentium-PC (300 MHz or faster is recommended)
- ◆ 64 MB RAM (128 MB recommended)
- ◆ Required HD capacity
 - ◆ CD installation: 350 MB before the installation, 200 MB after the installation is complete
- ◆ Super VGA-Monitor (with a resolution of at least 800 x 600, setting: small fonts)

Connection between PC and Compax3

Your PC is connected with Compax3 over an RS232 cable (**SSK1**(see on page 211)) (COM ½ interface on the PC based on X10 Compax3).

Start the Compax3 ServoManager and make the setting for the selected interface in the menu Options: Port (RS232) COM 1 or COM 2.

Device Selection

In the menu tree under device selection you can read the device type of the connected device (Online Device Identification) or select a device type (Device Selection Wizard).

Configuration

Then you can double click on "Configuration" to start the configuration wizard. The wizard will lead you through all input windows of the configuration.

Input quantities will be described in the following chapters, in the same order in which you are queried about them by the configuration wizard.

4.1.1. Selection of the supply voltage used

Please select the mains voltage for the operation of Compax3.
This influences the choice of motors available.

4.1.2. Motor Selection

The selection of motors can be broken down into:

- ◆ Motors that were purchased in Europe and
- ◆ Motors that were purchased in the USA.
- ◆ You will find non-standard motors under "Additional motors" and
- ◆ Under "User-defined motors" you can select motors set up with the C3 MotorManager.

For motors with holding brake SMHA or MHA you can enter brake deceleration times. For this, see **brake delay times** (see on page 123)

Please note the following equivalence that applies regarding terms to linear motors:

- ◆ **Rotary motors / linear motors**
- ◆ **Revolutions \equiv Pitch**
- ◆ **Rotation speed \equiv Speed**
- ◆ **Torque \equiv Power**
- ◆ **Moment of inertia \equiv Load**

Notes on direct drives (see on page 191) (Linear and Torque - Motors)

4.1.3. Optimize motor reference point and switching frequency of the motor current

Optimization of the motor reference point

The motor reference point is defined by the reference current and the reference (rotational) speed.

Standard settings are:

- ◆ Reference current = nominal current
- ◆ Reference (rotational) speed = nominal (rotational) speed

These settings are suitable for most cases.

The motors can, however, be operated with different reference points for special applications.

- ◆ By reducing the reference (rotational) speed, the reference current can be increased. This results in more torque with a reduced speed.
- ◆ For applications where the reference current is only required cyclically with long enough breaks in between, you may use a reference current higher than I_0 . The limit value is however reference current = max. $1.33 \cdot I_0$. The reference (rotational) speed must also be reduced.

The possible settings or limits result from the respective motor characteristics.

Caution!



Wrong reference values (too high) can cause the motor to switch off during operation (because of too high temperature) or even cause damage to the motor.

Optimization of the switching frequency

The switching frequency of the power output stage is preset to optimize the operation of most motors.

It may, however, be useful to increase the switching frequency especially with direct drives in order to reduce the noise of the motors. Please note that the power output stage must be operated with reduced nominal currents in the case of increased switching frequencies.

The switching frequency may only be increased.

**Caution!**

By increasing the switching frequency of the motor current, the nominal current and the peak current are reduced.

This must already be observed in the planning stage of the plant!

The preset motor current switching frequency depends on the performance variant of the Compax3 device.

The respective Compax3 devices can be set as follows:

Resulting nominal and peak currents depending on the switching frequency

Compax3 S0xx V2 at 1*230VAC/240VAC

Switching frequency*		S025 V2	S063 V2
16kHz	I_{nominal}	2.5A _{eff}	6.3A _{eff}
	$I_{\text{peak}} (<5\text{s})$	5.5A _{eff}	12.6A _{eff}
32kHz	I_{nominal}	2.5A _{eff}	5.5A _{eff}
	$I_{\text{peak}} (<5\text{s})$	5.5A _{eff}	12.6A _{eff}

Compax3 S1xx V2 at 3*230VAC/240VAC

Switching frequency*		S100 V2	S150 V2
8kHz	I_{nominal}	-	15A _{eff}
	$I_{\text{peak}} (<5\text{s})$	-	30A _{eff}
16kHz	I_{nominal}	10A _{eff}	12.5A _{eff}
	$I_{\text{peak}} (<5\text{s})$	20A _{eff}	25A _{eff}
32kHz	I_{nominal}	8A _{eff}	10A _{eff}
	$I_{\text{peak}} (<5\text{s})$	16A _{eff}	20A _{eff}

Compax3 S0xx V4 at 3*400VAC

Switching frequency*		S015 V4	S038 V4	S075 V4	S150 V4	S300 V4
8kHz	I_{nominal}	-	-	-	15A _{eff}	30A _{eff}
	$I_{\text{peak}} (<5\text{s})$	-	-	-	30A _{eff}	60A _{eff}
16kHz	I_{nominal}	1.5A _{eff}	3.8A _{eff}	7.5A _{eff}	10.0A _{eff}	26A _{eff}
	$I_{\text{peak}} (<5\text{s})$	4.5A _{eff}	9.0A _{eff}	15.0A _{eff}	20.0A _{eff}	52A _{eff}
32kHz	I_{nominal}	1.5A _{eff}	2.5A _{eff}	3.7A _{eff}	5.0A _{eff}	14A _{eff}
	$I_{\text{peak}} (<5\text{s})$	3.0A _{eff}	5.0A _{eff}	10.0A _{eff}	10.0A _{eff}	28A _{eff}

Compax3 S0xx V4 at 3*480VAC

Switching frequency*		S015 V4	S038 V4	S075 V4	S150 V4	S300 V4
8kHz	I_{nominal}	-	-	-	13.9A _{eff}	30A _{eff}
	$I_{\text{peak}} (<5\text{s})$	-	-	-	30A _{eff}	60A _{eff}
16kHz	I_{nominal}	1.5A _{eff}	3.8A _{eff}	6.5A _{eff}	8.0A _{eff}	21.5A _{eff}
	$I_{\text{peak}} (<5\text{s})$	4.5A _{eff}	7.5A _{eff}	15.0A _{eff}	16.0A _{eff}	43A _{eff}
32kHz	I_{nominal}	1.0A _{eff}	2.0A _{eff}	2.7A _{eff}	3.5A _{eff}	10A _{eff}
	$I_{\text{peak}} (<5\text{s})$	2.0A _{eff}	4.0A _{eff}	8.0A _{eff}	7.0A _{eff}	20A _{eff}

The values marked with grey are the pre-set values (standard values)!

*corresponds to the frequency of the motor current

4.1.4. Braking Resistor

If the regenerative braking power that is fed back exceeds the **storable energy of the servo controller** (see on page 226), an error will be generated. To ensure safe operation, it is then necessary to either

- ◆ reduce the accelerations resp. the decelerations,
- ◆ or you will need an **external braking resistor** (see on page 203)

Please select the connected braking resistor or enter the characteristic values of your braking resistor directly.

Please note that with resistance values greater than specified, the power output from the servo drive can no longer be dissipated in the braking resistor.

4.1.5. General Drive

External moment of inertia / load

The external moment of inertia is required for adjusting the servo controller. The more accurately the moment of inertia of the system is known, the better is the stability and the shorter is the settle-down time of the control loop.

It is important to specify the minimum and maximum moment of inertia for best possible behavior under varying load.

Minimum moment of inertia / minimum load

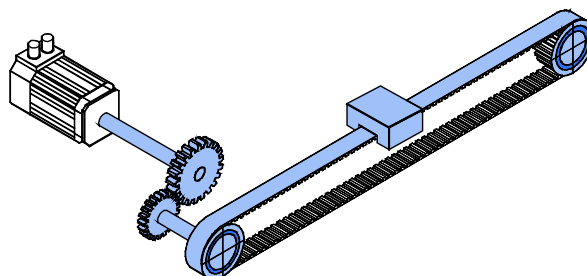

Maximum moment of inertia / maximum load

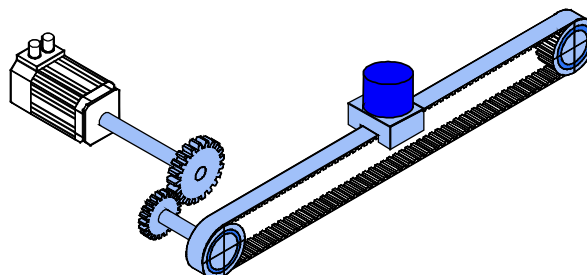

Enter minimum = maximum moment of inertia when the load does not vary.

4.1.6. Defining the reference system

The reference system for positioning is defined by:

- ◆ a unit,
- ◆ the travel distance per motor revolution,
- ◆ a machine zero point with true zero,
- ◆ positive and negative end limits.

4.1.6.1 Measure reference

You can select from among the following for the unit:

Unit of Travel

- ◆ mm,
- ◆ increments or
- ◆ angle degree.

The unit of measure is always [mm] for linear motors.

Travel distance per motor revolution / pitch

The measure reference to the motor is created with the value: "travel distance per motor revolution / pitch" in the selected unit.

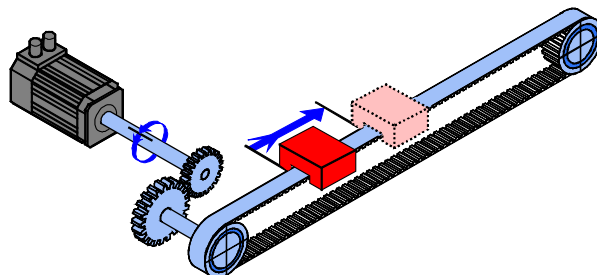

Input as numerator and denominator

You can enter the "travel distance per motor revolution" as a fraction (numerator divided by denominator). This is useful in the case of continuous operation mode or in reset mode if the value cannot be specified as a rational number. This makes it possible to avoid long-term drifts.

Example 1:

Rotary table control

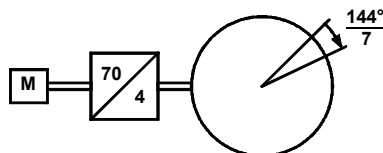

Unit: Degrees

Gear transmission ratio 70:4 => 4 load revolutions = 70 motor revolutions

Travel distance per motor revolution = $4/70 * 360^\circ = 20.571\ 428\ 5 \dots^\circ$ (number cannot be represented exactly)

Instead of this number, you have the option of entering it exactly as a numerator and denominator:

Travel distance per motor revolution = $144/7$

This will not result in any drift in continuous operation mode or in reset mode, even with relatively long motion in one direction.

Example 2:

Conveyor belt

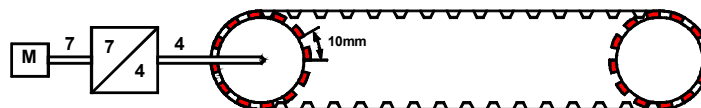

Unit: mm

Gear transmission ratio 7:4 => 4 load revolutions = 7 motor revolutions

Number of pinions: 12

Tooth separation: 10mm

Travel path per motor revolution = $4/7 * 12 * 10\text{mm} = 68.571\ 428\ 5 \dots \text{mm}$ (this number cannot be expressed exactly)

Instead of this number, you have the option of entering it exactly as a numerator and denominator:

Travel distance per motor revolution = $480/7 \text{ mm}$

For "travel distance per motor revolution" that can be represented exactly, enter 1 as the denominator.

Travel distance per motor revolution / pitch
Numerator

Unit: Unit of Travel	Range: depending on the chosen unit	Standard value: depending on the chosen unit
Resolution: 0.000 000 1 (7 decimal places)		
Unit of Travel	Division	Standard value
Increments*	10 ... 1 000 000	1024
mm	0,010 000 0 ... 2000,000 000 0	1,000 000 0
Degrees	0,010 000 0 ... 720,000 000 0	360,000 000 0

Denominator

Unit: -	Range: 1 ... 1 000 000	Standard value: 1
Integer value		

* If the "Increments" unit is selected, this applies only to position values; speed, acceleration and jerk are specified in this case in revolutions/s, revolutions/s² and revolutions/s³ (or pitch/s, pitch/s², pitch/s³).

Invert Motor Rotation/Direction Sense

Unit: -	Range: no/yes	Standard value: no
Reverse direction inverts the sense of rotation, i.e. the direction of movement of the motor is reversed in the case of equal setpoint.		

Reset mode

Reset mode is available for applications in which the positioning range repeats; some examples are: Rotary table applications, belt conveyor,

After the reset travel distance (can be specified exactly as **numerator and denominator** (see on page 63)) the position values in Compax3 are reset to 0.

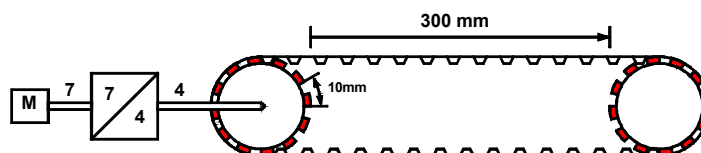
Example:
Conveyor belt (from the "Conveyor belt" example) with reset path

A reset path of 300 mm can be entered directly with numerator = 300 mm and denominator = 1.

Reset mode is not possible for linear motors.

Reset Distance

Numerator

Unit: Unit of Travel	Range: depending on the chosen unit	Standard value: depending on the chosen unit
Unit of Travel	Division	Standard value
Increments	10 ... 1 000 000	0
mm	1 ... 2000	0
Degrees	1 ... 720	0

Denominator

Unit: -	Range: 1 ... 1 000 000	Standard value: 0
Integer value		

Turn off reset mode

Reset mode is turned off for numerator = 0 and denominator = 0.

4.1.6.2 Machine Zero

In this chapter you can read about:

Operation with SinCos Multiturn	67
Operation with MultiTurn emulation	67
Machine zero modes overview	68
Homing modes with home switch (on X12/14)	70
Machine zero modes without home switch	76
Adjusting the machine zero proximity switch	81
Machine zero speed and acceleration	81

The Compax3 machine zero modes are adapted to the CANopen profile for Motion Control CiADS402.

Position reference point

Essentially, you can select between operation with or without machine reference. The reference point for positioning is determined by using the machine reference and the machine reference offset.

Machine reference run

In a homing run the drive moves to the position value 0 immediately after finding the home switch. The position value 0 is defined via the homing offset.

A machine reference run is required each time after turning on the system for operation with machine reference.



Please note:

During homing run the software end limits are not monitored.

If the homing mode is active, there will always be a **homing run** (see on page 102) with the first start after each configuration download (with the aid of the C3 ServoManager).

Operation with SinCos Multiturn

Using a SinCos Multiturn absolute value encoder (Motor - Option A7) as feedback system, the absolute position can be read in when switching on the Compax3. A machine zero run after switch-on is then not necessary.

In this case the reference only needs to be established once

- ◆ at initial commissioning time
- ◆ after an exchange of motor / feedback system
- ◆ after a mechanical modification and
- ◆ after replacing the device (Compax3)
- ◆ after a configuration download

by carrying out a machine zero run.

The homing mode 35 "MN-M 35: **home at the current position**" (see on page 76) is appropriate for this, because it is therewith possible to operate without proximity switch, but any other homing mode is possible too - if the hardware prerequisites are fulfilled.

When you have once re-established the reference, reset the homing mode to "without homing run".

Operation with MultiTurn emulation

You can simulate the function of a SinCos Multiturn by the aid of a Multiturn emulation. A resolver or a SinCos Singleturn is sufficient as a feedback signal from the motor.

It differs from the physical SinCos Multiturn in the way that it may not be moved by more than half a turn in currentless state – unless the absolute position is lost.

Besides that, the Multiturn emulation offers the same function as the physical SinCos Multiturn.

You can switch on the Multiturn emulation directly in the wizard.

You can assign the maximum permissible motor angle via the Multiturn validity window

If Compax3 states after switching on that this value is not exceeded, the "referenced" will be set (status word Bit 12 or output M.O8).

Compax3 restores nevertheless the absolute position, which is, however, not correct, if the motor was moved by more than the validity window while currentless.

Machine reference run

For a unique machine zero run the same conditions apply as for the use of an absolute encoder (SinCos Multiturn).

Machine zero modes overview
Selection of the machine zero modes (MN-M)

Machine zero initiator on X12/14: MN-M 3 ... 14, 19 ... 30	Without motor reference point MN-M 19 ...30	without direction reversal switches MN-M 19, 20 (see on page 70) MN-M 21, 22 (see on page 71)
		Search for Home in opposite direction MN-M 23, 24, 25, 26 (see on page 72) MN-M 27, 28, 29, 30 (see on page 72)
	With motor reference point MN-M 3 ... 14	without direction reversal switches MN-M 3, 4 (see on page 73) MN-M 5, 6 (see on page 74)
		Search for Home in opposite direction MN-M 7, 8, 9, 10 (see on page 75) MN-M 11,12,13, 14 (see on page 75)
Without machine zero initiator on X12/14: MN-M 1, 2, 17, 18, 33 .. 35, 128, 129, 130 ... 133	Without motor reference point MN-M 17, 18, 35, 128, 129	MN-M 35: at the current position (see on page 76) MN-M 128, 129: by moving to block (see on page 76)
		Use of HW travel limit switch as Home switch MN-M 17, 18 (see on page 77)
	With motor reference point	Only motor reference MN-M 33, 34 (see on page 78) MN-M 130, 131 (see on page 78)
		MN-M 1, 2, 33, 34, 130 ... 133 Use of HW travel limit switch as Home switch MN-M 1, 2 (see on page 79) MN-M 132, 133 (see on page 80)

Definition of terms / explanations:

Motor zero point	Zero pulse of the feedback Motor feedback systems such as resolvers or SinCos give one pulse per motor revolution. Some motor feedback systems of direct drives do also have a zero pulse, which is generated once or in defined intervals. By interpreting the motor zero point (generally in connection with the machine zero initiator) the machine zero can be defined more exactly.
Machine zero initiator:	For creating the mechanical reference Has a defined position within or on the edge of the travel range.
Direction reversal switches:	Initiators on the edge of the travel range, which are used only with a machine zero run in order to detect the end of the travel range. In some cases, the function “ direction reversal via current“ is also possible, then you will need no initiator, Compax3 detects the end of the travel range as a result of a rise in current. Please observe the respective notes. During operation, the direction reversal switches are often used as limit switches.

Example axis with the initiator signals

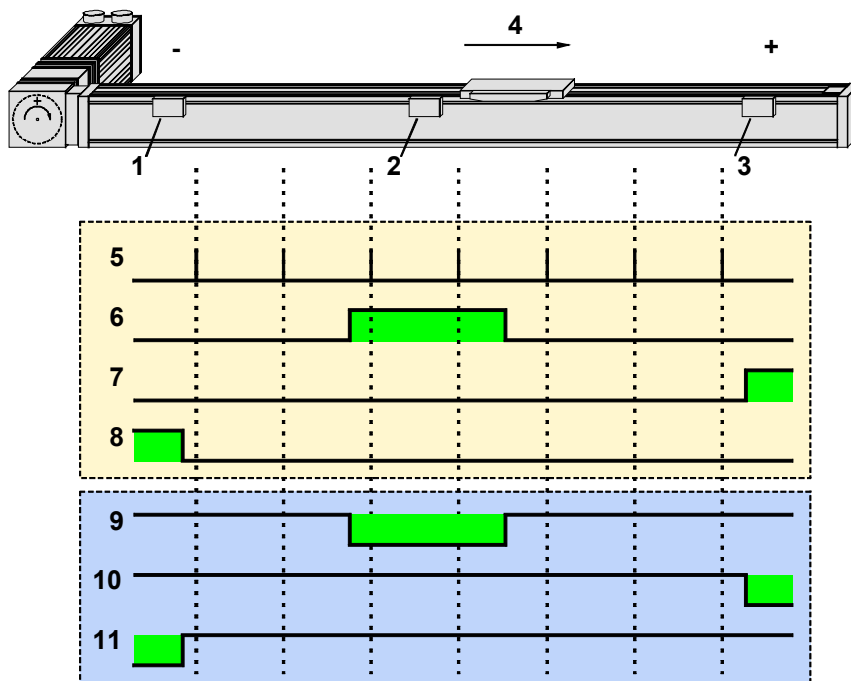

- 1: Direction reversal / end switch on the end of the travel range (the **assignment of the direction reversal/end switches** (see on page 86) to travel range side can be changed).
- 2: Machine zero initiator (can, in this example, be released to 2 sides)
- 3: Direction reversal resp. end switch on the positive end of the travel range. (the **assignment of the direction reversal/end switch inputs** (see on page 86) to travel range side can be changed).
- 4: Positive direction of movement
- 5: Signals of the motor zero point (zero pulse of the motor feedback)
- 6: Signal of the machine zero initiator (**without inversion of the initiator logic** (see on page 86))
- 7: Signal of the direction reversal resp. end switch on the positive end of the travel range (without inversion of the initiator logic).
- 8: Signal of the direction reversal / resp. end switch on the negative end of the travel range (without inversion of the initiator logic).
- 9: Signal of the machine zero initiator (**with inversion of the initiator logic** (see on page 86)).
- 10: Signal of the direction reversal resp. end switch on the positive end of the travel range (with inversion of the initiator logic).
- 11: Signal of the direction reversal / end switch on the negative end of the travel range (with inversion of the initiator logic).

Homing modes with home switch (on X12/14)

In this chapter you can read about:

Debouncing the machine zero input (X12/14) 70
 Without motor reference point 70
 With motor reference point 73

Debouncing the machine zero input (X12/14)

A majority gate is used for debouncing.
 The signal is sampled every 0.5ms.
 The debounce time determines the number of scans the majority gate will perform.
 If the level of more than half of the signals was changed, the internal status will change.
 The debounce time can be set in the configuration wizard within the range of 0 ... 20ms.
 The value 0 deactivates the debouncing.

Without motor reference point

Without direction reversal switches

MN-M 19.20: MN-Initiator = 1 on the positive side

The MN initiator can be positioned at any location within the travel range. The travel range is then divided into 2 contiguous ranges: one range with deactivated MN initiator (left of the MN initiator) and one range with activated MN initiator (right of the MN initiator).
 When the MN initiator is inactive (signal = 0) the search for the machine reference is in the positive travel direction.

Without motor zero point, without direction reversal switches

MN-M 19: The negative edge of the MN proximity switch is taken directly as MN (the motor zero point remains without consideration).
MN-M 20: The positive edge of the MN proximity switch is used directly as MN (the motor zero point remains without consideration).

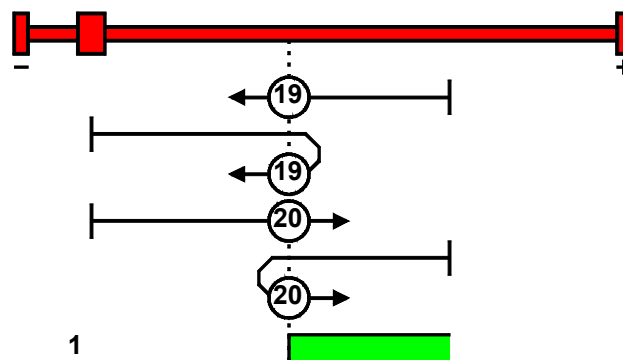

1: Proximity switch signal level

MN-M 21.22: MN proximity switch = 1 on the negative side

The MN initiator can be positioned at any location within the travel range. The travel range is then divided into 2 contiguous ranges: one range with deactivated MN initiator (positive part of the travel range) and one range with activated MN initiator (negative part of the travel range).

When the MN initiator is inactive (signal = 0) the search for the machine reference is in the negative travel direction.

Without motor zero point, without direction reversal switches

MN-M 21: The negative edge of the MN proximity switch is taken directly as MN (the motor zero point remains without consideration).

MN-M 22: The positive edge of the MN proximity switch is used directly as MN (the motor zero point remains without consideration).

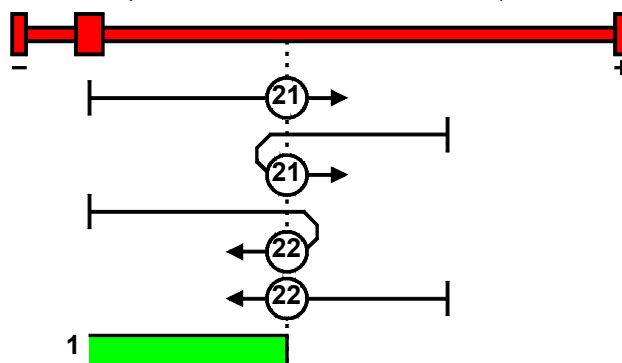

1: Proximity switch signal level

With direction reversal switches

Machine zero modes with a home switch which is activated in the middle of the travel range and can be deactivated to both sides.

The **assignment of the direction reversal switches** (see on page 86) can be changed.

Function Home in opposite direction when Current (Torque) limit is reached

If no direction reversal switches are available, the reversal of direction can also be performed during the machine zero run via the function “direction reversal via current”.

Here the drive runs towards the mechanical limit mounted at the end of the travel range.

The current rises. When the adjustable current limit is reached, the drive is decelerated and changes the direction of movement.

	<p>Caution! Wrong settings can cause hazard for man and machine.</p>
---	---

It is therefore essential to respect the following:

- ◆ Choose a low machine zero speed.
- ◆ Set the machine zero acceleration to a high value, so that the drive changes direction quickly, the value must, however, not be so high that the current limit threshold is already reached by accelerating or decelerating (without mechanical limitation).
- ◆ The mechanical limitation as well as the load drain must be set so that they can absorb the resulting kinetic energy.

MN-M 23..0.26: Direction reversal switches on the positive side

Without motor zero point, with direction reversal switches

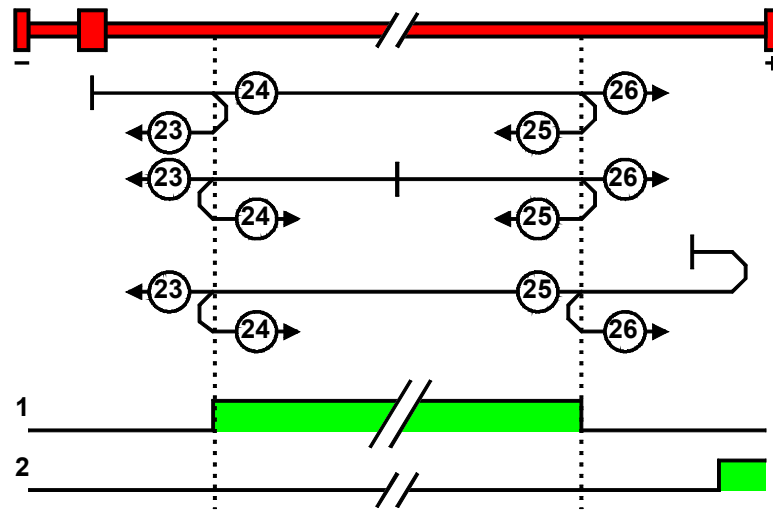

1: Initiator signal level of the home switch

2: Initiator signal level of the direction reversal switch

MN-M 27..0.30: With direction reversal switches on the negative side

Without motor zero point, with direction reversal switches

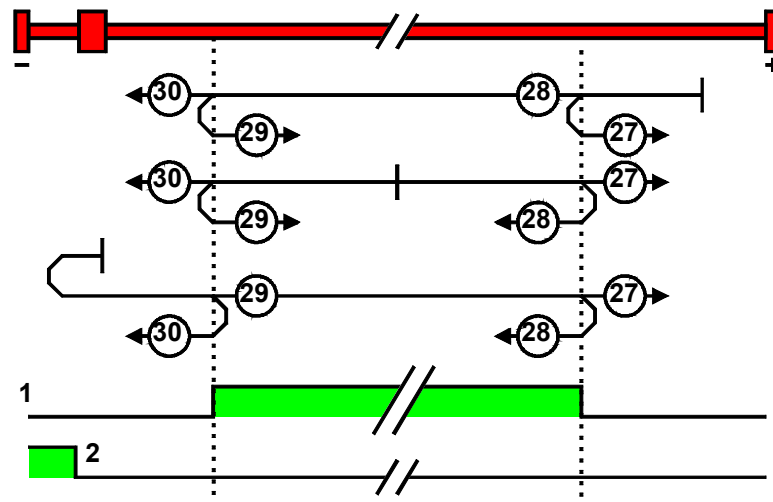

1: Initiator signal level of the home switch

2: Initiator signal level of the direction reversal switch

With motor reference point

Without direction reversal switches

MN-M 3.4: MN-Initiator = 1 on the positive side

The MN initiator can be positioned at any location within the travel range. The travel range is then divided into 2 contiguous ranges: one range with deactivated MN initiator (left of the MN initiator) and one range with activated MN initiator (right of the MN initiator).

When the MN initiator is inactive (signal = 0) the search for the machine reference is in the positive travel direction.

With motor zero point, without direction reversal switches

MN-M 3: The 1st motor zero point at MN proximity switch = "0" is used as MN.

MN-M 4: The 1st motor zero point at MN proximity switch = "1" is used as MN.

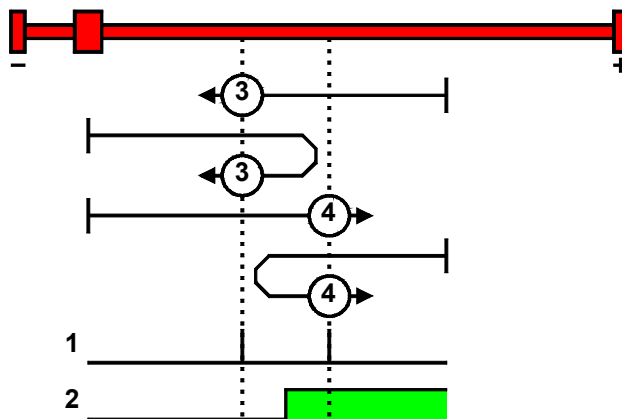

- 1: Motor zero point
- 2: Initiator signal level of the home switch

MN-M 5.6: MN proximity switch = 1 on the negative side

The MN initiator can be positioned at any location within the travel range. The travel range is then divided into 2 contiguous ranges: one range with deactivated MN initiator (positive part of the travel range) and one range with activated MN initiator (negative part of the travel range).

When the MN initiator is inactive (signal = 0) the search for the machine reference is in the negative travel direction.

With motor zero point, without direction reversal switches

MN-M 5: The 1st motor zero point with MN proximity switch = "0" is used as MN.

MN-M 6: The 1st motor zero point at MN proximity switch = "1" is used as MN.

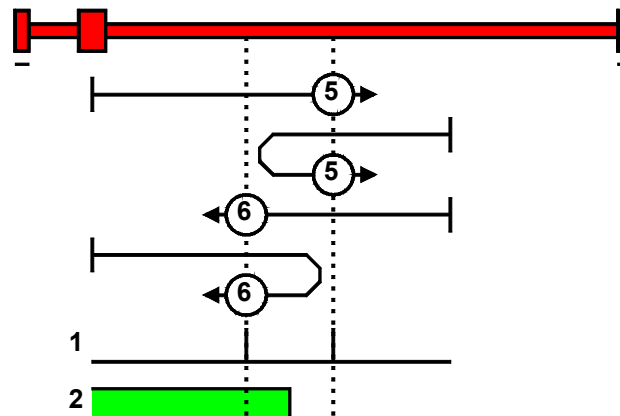

1: Motor zero point

2: Initiator signal level of the home switch

With direction reversal switches

Machine zero modes with a home switch which is activated in the middle of the travel range and can be deactivated to both sides.

The **assignment of the direction reversal switches** (see on page 86) can be changed.

Function Home in opposite direction when Current (Torque) limit is reached

If no direction reversal switches are available, the reversal of direction can also be performed during the machine zero run via the function "direction reversal via current".

Here the drive runs towards the mechanical limit mounted at the end of the travel range.

The current rises. When the adjustable current limit is reached, the drive is decelerated and changes the direction of movement.

	Caution! Wrong settings can cause hazard for man and machine.
--	---

It is therefore essential to respect the following:

- ◆ Choose a low machine zero speed.
- ◆ Set the machine zero acceleration to a high value, so that the drive changes direction quickly, the value must, however, not be so high that the current limit threshold is already reached by accelerating or decelerating (without mechanical limitation).
- ◆ The mechanical limitation as well as the load drain must be set so that they can absorb the resulting kinetic energy.

With motor zero point, with direction reversal switches

MN-M 7..0.10: Direction reversal switches on the positive side

Machine zero modes with a home switch which is activated in the middle of the travel range and can be deactivated to both sides.

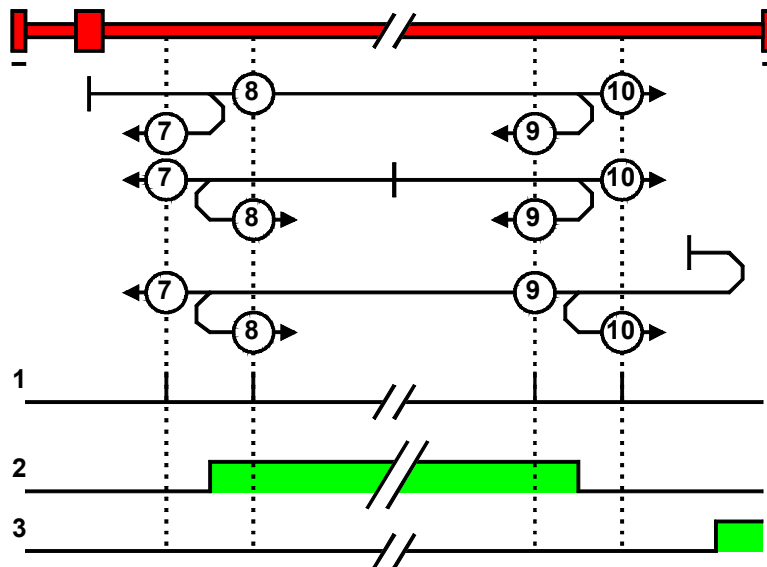

- 1: Motor zero point
- 2: Initiator signal level of the home switch
- 3: Initiator signal level of the direction reversal switch

With motor zero point, with direction reversal switches

MN-M 11...14: With direction reversal switches on the negative side

Machine zero modes with a home switch which is activated in the middle of the travel range and can be deactivated to both sides.

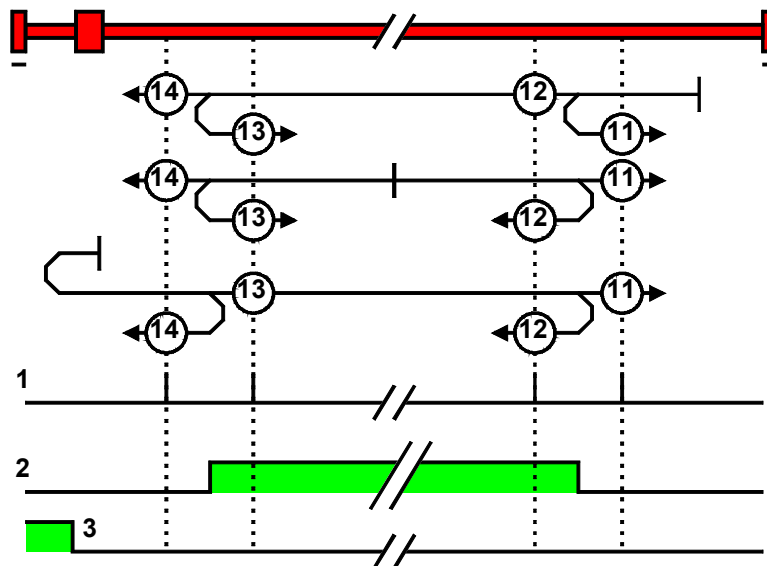

- 1: Motor zero point
- 2: Initiator signal level of the home switch
- 3: Initiator signal level of the direction reversal switch

Machine zero modes without home switch

Without motor reference point

MN-M 35: MN at the current position

The current position when the MN run is activated is used as an MN.

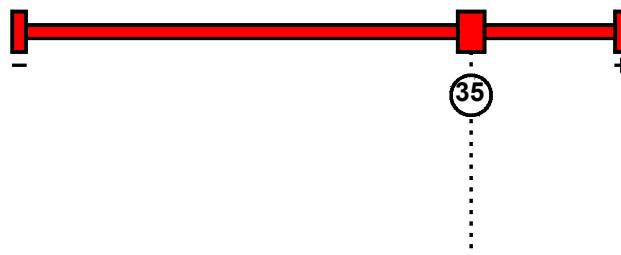

MN-M 128/129: current increase while moving to block

Without an MN initiator, an end of travel region (block) is used as an MN.

The increase in the current is evaluated for this purpose (adjustable up to 100% of the reference current), if the motor is pressing against the end of the travel region. If the limit is exceeded, the MN is set. Following error is deactivated during the MN run.

Please observe: The homing offset must be set so that the home (reference point) for positioning lies within the travel range.

MN-M 128: Travel in the positive direction to the end of the travel region



MN-M 129: Travel in the negative direction to the end of the travel region



Caution!

Wrong settings can cause hazard for man and machine.

It is therefore essential to respect the following:

- ◆ Choose a low machine zero speed.
- ◆ Set the machine zero acceleration to a high value, so that the drive changes direction quickly, the value must, however, not be so high that the current limit threshold is already reached by accelerating or decelerating (without mechanical limitation).
- ◆ The mechanical limitation as well as the load drain must be set so that they can absorb the resulting kinetic energy.

MN-M 17.18: Limit switch as machine zero

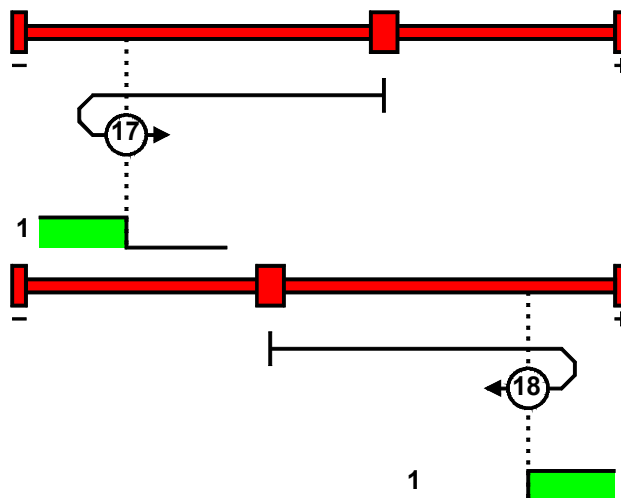

1: Initiator signal level of the direction reversal switch

Function Home in opposite direction when Current (Torque) limit is reached

If no direction reversal switches are available, the reversal of direction can also be performed during the machine zero run via the function “direction reversal via current”.

Here the drive runs towards the mechanical limit mounted at the end of the travel range.

The current rises. When the adjustable current limit is reached, the drive is decelerated and changes the direction of movement.

	<p>Caution! Wrong settings can cause hazard for man and machine.</p>
---	---

It is therefore essential to respect the following:

- ◆ Choose a low machine zero speed.
- ◆ Set the machine zero acceleration to a high value, so that the drive changes direction quickly, the value must, however, not be so high that the current limit threshold is already reached by accelerating or decelerating (without mechanical limitation).
- ◆ The mechanical limitation as well as the load drain must be set so that they can absorb the resulting kinetic energy.

With motor reference point

Machine zero only from motor reference

MN-M 33,34: MN at motor zero point

The motor reference point is now evaluated (no MN initiator):

Without home switch

MN-M 33: For a MN run, starting from the current position, the next motor zero point in the negative travel direction is taken as the MN.

MN-M 34: For a MN run, starting from the current position, the next motor zero point in the positive travel direction is taken as the MN.

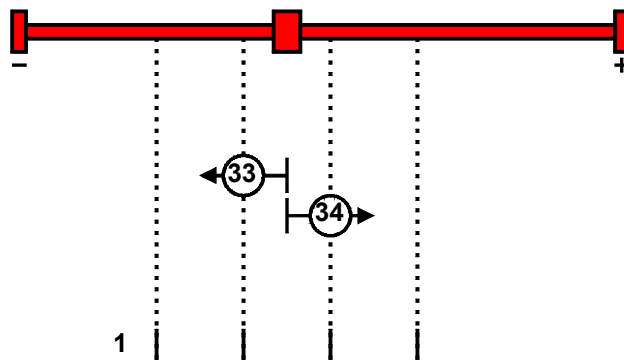

1: Motor zero point

MN-M 130, 131: Determine absolute position via distance coding

Only for motor feedback with distance coding (the absolute position can be determined via the distance value).

Compax3 determines the absolute position from the distance of two signals and then stops the movement (does not automatically move to position 0).

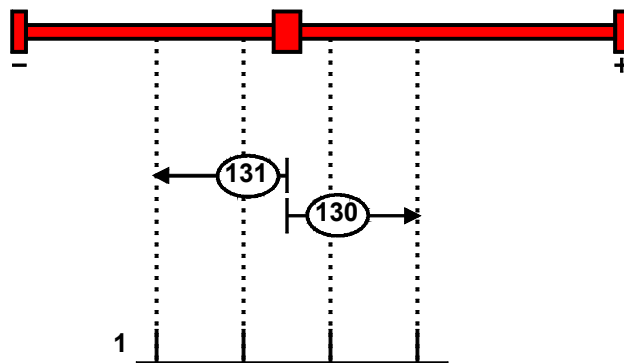

1: Signals of the distance coding

With direction reversal switches

Machine zero modes with a home switch which is activated in the middle of the travel range and can be deactivated to both sides.

The **assignment of the direction reversal switches** (see on page 86) can be changed.

Function Home in opposite direction when Current (Torque) limit is reached

If no direction reversal switches are available, the reversal of direction can also be performed during the machine zero run via the function “direction reversal via current”.

Here the drive runs towards the mechanical limit mounted at the end of the travel range.

The current rises. When the adjustable current limit is reached, the drive is decelerated and changes the direction of movement.

	<p>Caution! Wrong settings can cause hazard for man and machine.</p>
---	---

It is therefore essential to respect the following:

- ◆ Choose a low machine zero speed.
- ◆ Set the machine zero acceleration to a high value, so that the drive changes direction quickly, the value must, however, not be so high that the current limit threshold is already reached by accelerating or decelerating (without mechanical limitation).
- ◆ The mechanical limitation as well as the load drain must be set so that they can absorb the resulting kinetic energy.

MN-M 1.2: Limit switch as machine zero

End switch on the negative side

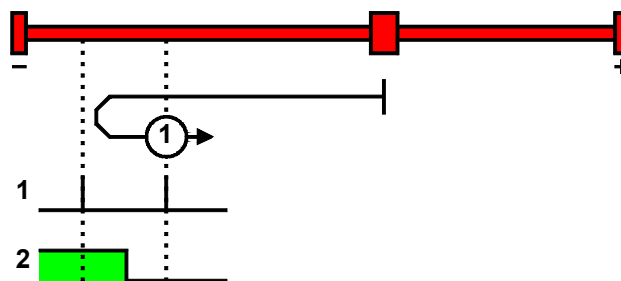

- 1: Motor zero point
- 2: Initiator level of the home switch

End switch on the positive side:

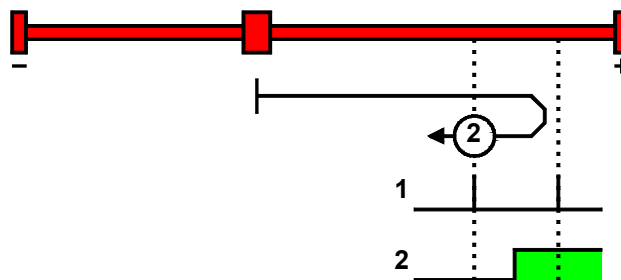

- 1: Motor zero point
- 2: Initiator level of the home switch

MN-M 132, 133: Determine absolute position via distance coding with direction reversal switches

Only for motor feedback with distance coding (the absolute position can be determined via the distance value).

Compax3 determines the absolute position from the distance of two signals and then stops the movement (does not automatically move to position 0).

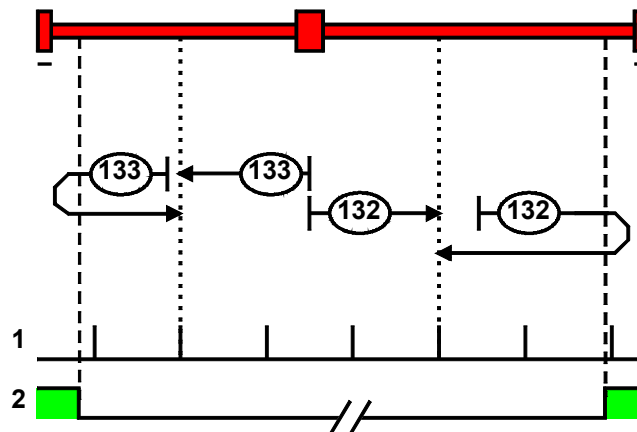

- 1: Signals of the distance coding
- 2: Initiator level of the direction reversal switches

Adjusting the machine zero proximity switch

This is helpful in some cases with homing modes that work with the home switch and motor reference point.

If the motor reference point happens to coincide with the position of the MN initiator, there is a possibility that small movements in the motor position will cause the machine reference point to shift by one motor revolution (to the next motor reference point).

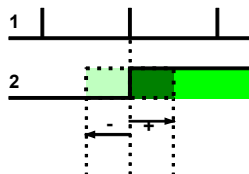

- 1: Motor zero point
- 2: Initiator level of the home switch

A solution to this problem is to move the MN initiator by means of software. This is done using the value initiator adjustment.

Initiator adjustment

Unit: Motor angle in degrees	Range: -360 ... 360	Standard value: 0
Move the machine reference initiator using software		

Machine reference offset

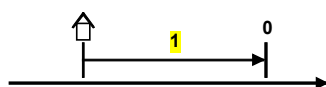

- 1: Machine reference offset

The machine reference offset is used to determine the actual reference point for positioning.

The rule for this is: Zero point = Machine zero + Machine zero offset

Note: If the machine zero proximity switch is at the positive end of the travel range, the machine zero offset must be = 0 or negative.

A change in the machine reference offset does not take effect until the next machine reference run.

Machine zero speed and acceleration

With these values you can define the motion profile of the machine zero run.

4.1.6.3 Travel Limit Settings

Software end limits

The travel range is defined via the negative and positive end limits.

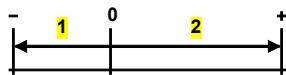

1: negative end limit

2: positive end limit

Software end limit in absolute operating mode

The positioning is restricted to the range between the travel limits.

A positioning order aiming at a target outside the travel range is not executed.

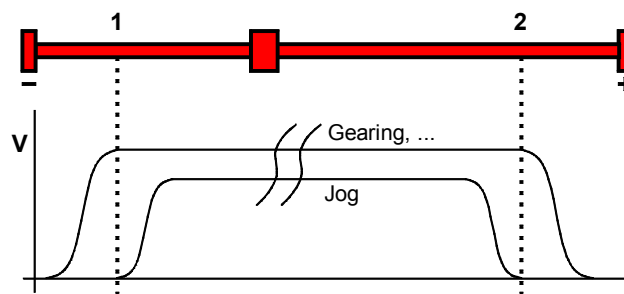

1: negative end limit

2: positive end limit

The reference is the position reference point that was defined with the machine reference and the machine reference offset.

Software end limits in reset mode

The reset mode does not support software end limits

Software end limit in continuous mode

Each individual positioning is confined within the travel limits.

A positioning order aiming at a target outside the software end limits is not executed.

The reference is the respective current position.

Error when disregarding the software end limits

A software end limit error is triggered, if the position value exceeds an end limit. For this, the position setpoint value is evaluated in energized state; in currentless state, the actual position value is evaluated.

Hysteresis in disabled state:

If the axis stands currentless at an end limit, another error may be reported due to position jitter after acknowledging the end limit error. To avoid this, a hysteresis surrounding the end limits was integrated (size corresponds to the size of the positioning window).

Only if the distance between axis and the end limits was larger than the positioning window, another end limit error will be detected

Error codes (see on page 170) of the end limit errors:

0x7323 Error when disregarding the positive software end limit.

0x7324 Error when disregarding the negative software end limit.

Activating / deactivating the end limit error:

The error can be (de)activated in the C3 ServoManager under configuration: end limits.

Behavior after the system is turned on

The end limits are not active after switching on. The end limits do not refer to the position reference point until after a machine reference run.

During homing run the end limits are not monitored.

Behavior outside the travel range

1. If the software end limit errors are deactivated, all movements are possible.

2. If the software end limit errors are activated:

After disregarding the software end limits, an error is triggered. First of all, this error must be acknowledged.

Then a direction block is activated: only motion commands in the direction of the travel range are executed. These will not trigger another error.

Motion commands inciting a movement in the opposite direction of the travel range are blocked and will trigger another error.

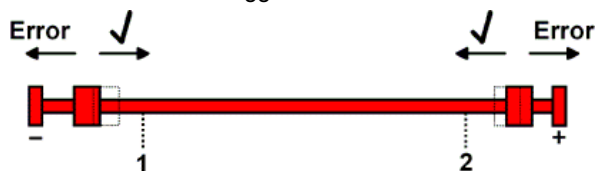

1: negative end limit

2: positive end limit

Behavior with software end limits of a referenced axis

	Position within target outside	Position outside target outside and aiming in the opposite direction of the travel range	Position outside target inside or and aiming in the direction of the travel range
JOG +/-	<ul style="list-style-type: none"> ◆ Positioning up to the end limits ◆ No Error 	<ul style="list-style-type: none"> ◆ No positioning ◆ No Error 	<ul style="list-style-type: none"> ◆ Positioning
MoveAbs, MoveRel, RegSearch, RegMove	<ul style="list-style-type: none"> ◆ No positioning ◆ Error 	<ul style="list-style-type: none"> ◆ No positioning ◆ Error 	<ul style="list-style-type: none"> ◆ Positioning
Gearing	<ul style="list-style-type: none"> ◆ Positioning up to the end limits ◆ Error 	<ul style="list-style-type: none"> ◆ No positioning ◆ Error 	<ul style="list-style-type: none"> ◆ No positioning ◆ Error
MoveVelocity	<ul style="list-style-type: none"> ◆ Positioning up to the end limits ◆ Error 	<ul style="list-style-type: none"> ◆ No positioning ◆ Error 	<ul style="list-style-type: none"> ◆ Positioning

Hardware end limits

Hardware end limits are implemented with the aid of end switches.

These are connected to X12/12 (input 5) and X12/13 (input 6) and can be (de)activated separately in the C3 ServoManager under Configuration: End limits.

After a limit switch has been detected, the drive decelerates with the ramp values set for errors (error code 0x54A0 at X12/12 active, 0x54A1 at X12/13 active).

Please make sure that after the detection of the limit switch there is enough travel path left up to the limit stop.

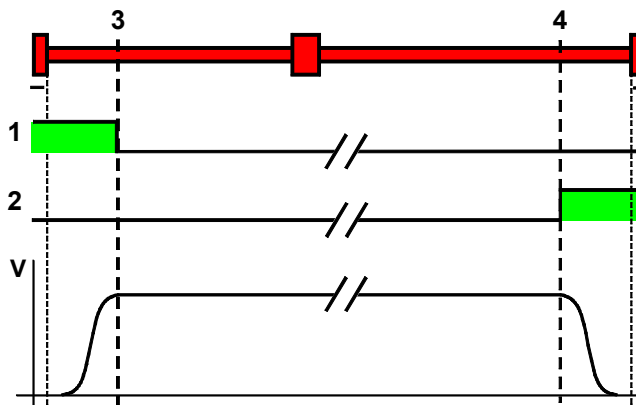

1: Limit switch E5 (X12/12)

2: Limit switch E6 (X12/13)

3: Limit switch position E5 (X12/12)

4: Limit switch position E6 (X12/13)

The **assignment of the limit switches** (see on page 86) can be changed!

Please note: The limit switches must be positioned so that they cannot be released towards the side to be limited.

Behavior in the case of an active limit switch The drive can then be moved out of the end switch range with a normal positioning. The direction of the movement is verified! Only the direction towards the travel range is allowed.

Limit switch / direction reversal switch Limit switches functioning as direction reversal switches during homing run, will not trigger a limit switch error.

Debouncing the limit switches

A majority gate is used for debouncing.

The signal is sampled every 0.5ms.

The debounce time determines the number of scans the majority gate will perform. If the level of more than half of the signals was changed, the internal status will change.

The debounce time can be set in the configuration wizard within the range of 0 ... 20ms.

The value 0 deactivates the debouncing.

4.1.6.4 Exchange assignment direction reversal / limit switches

If this function is not activated, the direction reversal / end switches are assigned as follows:

Direction reversal / limit switch on E5 (X12/12): negative side of the travel range

Direction reversal / limit switch on E6 (X12/13): Direction reversal / limit switch on E6 (X12/13):

Exchange assignment of direction reversal / limit switch is activated

If this function is activated, the direction reversal / limit switches are assigned as follows:

Direction reversal / limit switch on **E5** (X12/12): **positive side** of the travel range

Direction reversal / limit switch on **E6** (X12/13) **negative side** of the travel range

4.1.6.5 Change initiator logic

The initiator logic of the limit switches (this does also apply for the direction reversal switches) and the machine zero initiator can be changed separately.

- ◆ Limit switch E5 low active
- ◆ Limit switch E6 low active
- ◆ Home switch E7 low active

In the basic settings the inversion is deactivated, so that the signals are "high active".

With this setting the inputs I5 to I7 can even be switched within their logic, if they are not used as direction reversal/limit switches or machine zero.

4.1.7. Defining jerk / ramps

In this chapter you can read about:

Jerk limitation	87
Ramp upon error / deenergize.....	89

4.1.7.1 Jerk limitation

Jerk

The jerk (marked with “4” in the drawing below) describes the change in acceleration (derivation of the acceleration)

The maximum change in acceleration is limited via the jerk limitation.

A motion process generally starts from a standstill, accelerates constantly at the specified acceleration to then move at the selected speed to the target position. The drive is brought to a stop before the target position with the delay that has been set in such a manner as to come to a complete stop at the target position. To reach the set acceleration and deceleration, the drive must change the acceleration (from 0 to the set value or from the set value to 0).

This change in speed is limited by the maximum jerk.

**Without jerk
according to
VDI2143**

According to VDI2143 the jerk is defined (other than here) as the jump in acceleration (infinite value of the jerk function).

This means that positionings with Compax3 are without jerk according to VDI2143, as the value of the jerk function is limited.

Motion sequence

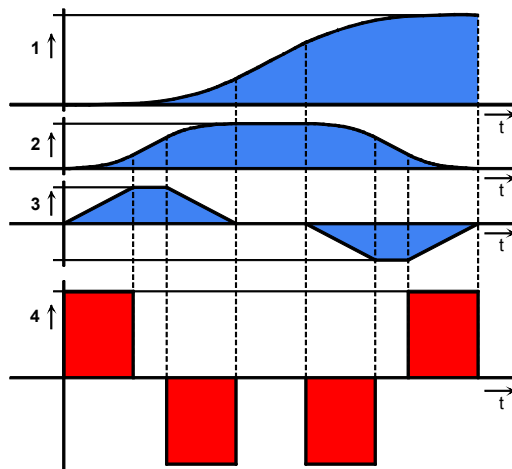

- 1: Position
- 2: Speed
- 3: Acceleration
- 4: Jerk

Changes in acceleration (jerks) often have negative effects on the mechanical systems involved. There is a danger that mechanical resonance points will be excited or that impacts will be caused by existing mechanical slack points. You can reduce these problems to a minimum by specifying the maximum jerk.

Jerk

Unit: Unit/s ³	Range: 0 ... 10 000 000	Standard value: 1 000 000
---------------------------	-------------------------	------------------------------

Deceleration on STOP

After a STOP signal, the drive applies the brakes with the delay that is set (2).

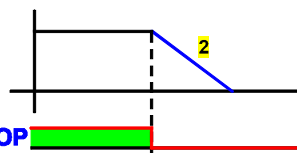

NO STOP: no STOP (E1, M.E6, CW.1 or CW.14)

4.1.7.2 Ramp upon error / deenergize

Ramp (delay) upon error and "De-energize"

The same delay is used for "Deenergizing" and when an error appears (errors which do not deenergize immediately).

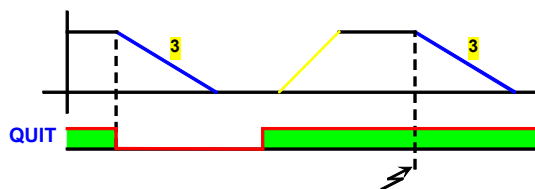

3: Deceleration on "de-energize" and on "error".

QUIT: I0: Quit or CW.0 (with positive edge)

START: M.E5: START or CW.13 (with positive edge)

JOG acceleration/deceleration and speed control

You can set the motion profile for moving with JOG+ or JOG- here.

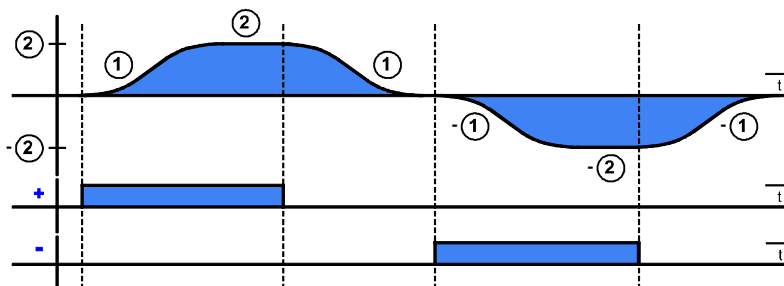

1: Manual acceleration / Deceleration

2: Manual speed control

+: I2: MANUAL+ or CW.2

-: I3: MANUAL- or CW.3

4.1.8. Monitoring / Limit Settings

In this chapter you can read about:

Current (Torque) Limit	89
Positioning window - Position reached	90
Following error limit.....	91
Maximum operating speed	92

4.1.8.1 Current (Torque) Limit

The current required by the speed controller is limited to the current limit.

4.1.8.2 Positioning window - Position reached

Position reached indicates that the target position is located within the position window.

In addition to the position window, a position window time is supported. If the actual position goes inside the position window, the position window time is started. If the actual position is still inside the position window after the position window time, "Position reached" is set.

If the actual position leaves the position window within the position window time, the position window time is started again.

When the actual position leaves the position window with Position reached = "1", Position reached is immediately reset to "0".

Position monitoring is active even if the position leaves the position window because of measures taken externally.

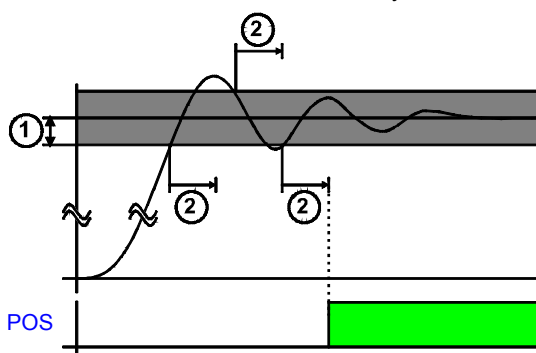

1: In Position Window (+/-)

2: In Position Window Time

POS: A1 and SW.9: Position reached

Linkage to the setpoint value

The signal "position reached" can be linked to the setpoint value.

In addition, the internal setpoint value generation is evaluated.

It applies: **The positioning window is only evaluated with a constant internal setpoint value.**

- Position reached with: Gearing** Signal "position reached" monitors synchronicity.
- RegSearch / RegMove** Signal "position reached" is set if
 - ◆ RegSearch was terminated without a reg being found or
 - ◆ Reg was found and RegMove executed.
- MoveVelocity** Signal "position reached" turns into "velocity reached".
- STOP** Signal "position reached" shows that the drive is at a standstill.

**No position monitoring takes place in status START (M.E5=24VDC or CW.13=1)
Therefore reset the start signal to 0 after the START edge.**

Behaviour of "Position reached" after Power On
 After Power On O1 (=SW Bit 9) = "0"
 After the machine zero run (after position 0 is reached) O1 and SW.9 goes to "1"

Handshake with PLC for small positionings

Example:

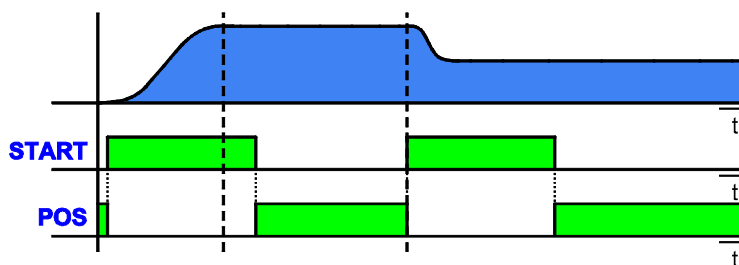

START: M.E5 or CW.13 = "1"
POS: O1: Position reached (= CW Bit 9)

Sequence:

PLC	Reaction Compax3
START of a positioning	Position reached goes to "0"
From position reached = "0" follows: START = 0	Positioning finished → Position reached = "1"
From position reached = "1" follows: Next START can take place	Position reached goes to "0"

4.1.8.3 Following error limit

The following error is a dynamic error.
 The dynamic difference between the setpoint position and the actual position during a positioning is called the following error. Do not confuse this with the static difference which is always 0; the target position is always reached exactly.

The change of position over time can be specified exactly using the parameters jerk, acceleration and speed. The integrated Setpoint value generator calculates the course of the target position. Because of the delay in the feedback loop, the actual position does not follow the setpoint position exactly. This difference is referred to as the following error.

Disadvantages caused by a following error

In joint operation of several servo controllers (e.g. master controller and slave controller), following errors lead to problems due to the dynamic position differences, and a large following error can lead to positioning overshoot.

Error message

If the following error exceeds the specified following error limit, the “following error time” then expires. If the following error is even greater than the following error limit at the end of the following error time, an error is reported.

If the following error falls short of the following error limit, a new following error time is then started.

Minimizing the following error

The following error can be reduced to a minimum with the aid of advanced control parameters, especially with **the forward control parameters** (see on page 116) (speed, acceleration, current and jerk feed forward).

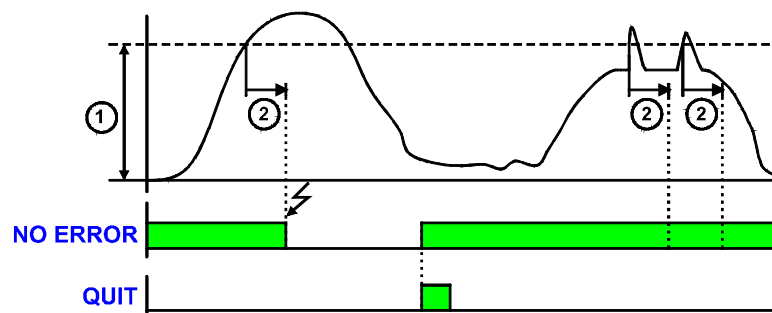

1: Following error limit

2: Following Error Time

NO ERROR: 00: no error

QUIT: I0: Quit (on positive edge)

4.1.8.4 Maximum operating speed

The speed limitation is derived from the maximum operating speed. In order to ensure control margins, the speed is limited to a higher value.

The speed setpoint value is actively limited to 1.1 times the given value.

If the speed actual value exceeds the preset maximum speed by 21% (=“switching off limit speed”), error 0x7310 is triggered.

4.1.9. Operating mode / I/O assignment

In this chapter you can read about:

I/O assignment for control via the Compax3 inputs/outputs..... 93
 I/O assignment, control word and status word with control via RS232 / RS485 95
 The operating mode defines the I/O assignment of the Compax3 I/Os.

4.1.9.1 I/O assignment for control via the Compax3 inputs/outputs

If control is not made via RS232 / RS485, an M - option (M10 or M12) will be required. The assignment of the inputs and outputs is fixed.

Assignment of the intra-device inputs and outputs



PIN X12	Input/output	High density/Sub D
1	O	+24VDC output (max. 400mA)
2	O0	No Error
3	O1	Position / velocity / gear synchronization reached (max. 100mA)
4	O2	No power output stage current (max. 100mA)
5	O3	Motor stationary with current, with setpoint 0 (max. 100mA)
6	I0="1":	Quit (positive edge) / Energize the motor The address of the current motion set is read in new.
	I0="0"	Motor deenergized with delay
7	I1	No stop
8	I2	JOG+
9	I3	JOG -
10	I4	Reg input
11	I	24V input for the digital outputs Pins 2 to 5
12	I5	Limitswitch 1
13	I6	Limitswitch 2
14	I7	Machine reference initiator
15	O	Gnd 24 V

All inputs and outputs have 24V level.

Maximum capacitive loading of the outputs: 50nF (max. 4 Compax3-inputs can be connected)

Assignment of the optional inputs and outputs (M option)

PIN X22/	Input/output	High density/Sub D	
1	n.c.	reserved	
2	M.I0	Address 0	free assingment at operation via RS232 / RS485
3	M.I1	Address 1	
4	M.I2	Address 2	
5	M.I3	Address 3	
6	M.I4	Address 4	
7	M.I5	Start (edge triggered)	
8	M.I6	no Stop (2nd Stop input)	
9	M.I7	Open motor holding brake	
10	M.O8	Machine zero (home) Position known	
11	I	24 VDC power supply	
12	M.O9	programmable status bit 0 (PSB0)	free assingment at operation via RS232 / RS485
13	M.O10	programmable status bit 1 (PSB1)	
14	M.O11	programmierbares Statusbit 2 (PSB2)	
15	I	Gnd 24 V	

- ◆ All inputs and outputs have 24V level.
- ◆ The input/output designation **M.I0** ... helps to make the distinction between the standard I/Os on X12 and the inputs/outputs of the **M** option.
- ◆ Maximum load on an output: 100mA
- ◆ Maximum capacitive load: 50nF (max. 4 Compax3 inputs)

Caution! The 24VDC power supply (X22/11) must be supplied from an external source and must be protected by a 1.2A delayed fuse!

Reaction times:

Example:

I0="1" (energize Motor) => O3="1" (Motor energized) max. 4ms

M.I5="1" (START edge) => O3="0" max. 4ms

4.1.9.2 I/O assignment, control word and status word with control via RS232 / RS485

- ◆ Control via RS232 / RS485 does not require an M option (M10 / M12).
- ◆ If an M option is available, 12 inputs/outputs (ports) are freely assignable. These can be configured as inputs or outputs by groups of four and be activated resp. read via **Object 121.2** (see page 147) and **Object 133.3** (see page 147).
- ◆ The signal inputs I4 ... I7 are fixedly assigned
If the respective functions are not required, these inputs can also be used for control purposes.
I5 and I6 can, for instance, be used as free inputs if the limit switch function is deactivated.



Assignment of the intra-device inputs and outputs

PIN X12	Input/output	High density/Sub D
1	O	+24VDC output (max. 400mA)
2	O0	No Error
3	O1	Position / velocity / gear synchronization reached (max. 100mA)
4	O2	No power output stage current (max. 100mA)
5	O3	Motor stationary with current, with setpoint 0 (max. 100mA)
6	I0="1":	Quit (positive edge) / Energize the motor The address of the current motion set is read in new.
	I0="0"	Motor deenergized with delay
7	I1	No stop
8	I2	JOG+
9	I3	JOG -
10	I4	Reg input
11	I	24V input for the digital outputs Pins 2 to 5
12	I5	Limitswitch 1
13	I6	Limitswitch 2
14	I7	Machine reference initiator
15	O	Gnd 24 V

All inputs and outputs have 24V level.

Maximum capacitive loading of the outputs: 50nF (max. 4 Compax3-inputs can be connected)

I/O Assignment

- ◆ Control via RS232 / RS485 does not require an M option (M10 / M12).
- ◆ If an M option is available, 12 inputs/outputs (ports) are freely assignable. These can be configured as inputs or outputs by groups of four and be activated resp. read via **Object 121.2** (see page 147) and **Object 133.3** (see page 147).
- ◆ The signal inputs I4 ... I7 are fixedly assigned
If the respective functions are not required, these inputs can also be used for control purposes.
I5 and I6 can, for instance, be used as free inputs if the limit switch function is deactivated.

Assignment of the intra-device inputs and outputs



PIN X12	Input/output	High density/Sub D
1	O	+24VDC output (max. 400mA)
2	O0	No Error
3	O1	Position / velocity / gear synchronization reached (max. 100mA)
4	O2	No power output stage current (max. 100mA)
5	O3	Motor stationary with current, with setpoint 0 (max. 100mA)
6	I0="1":	Quit (positive edge) / Energize the motor The address of the current motion set is read in new.
	I0="0"	Motor deenergized with delay
7	I1	No stop
8	I2	JOG+
9	I3	JOG -
10	I4	Reg input
11	I	24V input for the digital outputs Pins 2 to 5
12	I5	Limitswitch 1
13	I6	Limitswitch 2
14	I7	Machine reference initiator
15	O	Gnd 24 V

All inputs and outputs have 24V level.

Maximum capacitive loading of the outputs: 50nF (max. 4 Compax3-inputs can be connected)

For intra-device inputs I0 .. I3 as well as the outputs O0 ... O3 you can choose between fixed or free assignment.

With fixed assignment of the intra-device inputs I0 ... I3, the respective functions can either be triggered via the inputs or via RS232 / RS485.

The following rules apply:

- ◆ The motor is only energized if I0 = "1" AND control word Bit 0 = "1"
- ◆ Stop is active if, I1 = "0" OR Control word Bit 1 = "0"
- ◆ Manual+ and Manual- inputs and control word are OR - linked.

Control word

Layout of the control word (Object 1100.3 (see on page 156))

Bit	Function	Corresponds to *
Bit0	Quit (edge) / energize Motor	I0: X12/6
Bit1	No Stop	I1: X12/7
Bit2	JOG+	I2: X12/8
Bit3	JOG -	I3: X12/9
Bit4	O0 X12/2	(only if O0...O3 is defined as freely assignable)
Bit5	O1 X12/3	
Bit6	O2 X12/4	
Bit7	O3 X12/5	
Bit8	Address 0	
Bit9	Address 1	
Bit10	Address 2	
Bit11	Address 3	
Bit12	Address 4	
Bit13	Start (edge)	
Bit14	No Stop (2nd Stop)	
Bit15	Brake open	

* does only apply if the respective inputs are assigned fixedly.

Bit0 = least significant Bit

status word 1 & 2
Layout of the status word 1 (Object 1000.3 (see on page 157))

Bit	Description	Corresponds to *
Bit0	I0	X12/6
Bit1	E1	X12/7
Bit2	I2	X12/8
Bit3	I3	X12/9
Bit4	I4	X12/10
Bit5	I5	X12/11
Bit6	I6	X12/12
Bit7	I7	X12/13
Bit8	No Error	X12/2
Bit9	Position reached	X12/3
Bit10	Motor de-energized	X12/4
Bit11	Motor stationary with current at setpoint value zero	X12/5
Bit12	Machine zero (home) Position known	
Bit13	Programmable status bit 0 (PSB0)	
Bit14	Programmable status bit 1 (PSB1)	
Bit15	Programmable status bit 2 (PSB2)	

* Does apply for Bit 8 ... 11 only if the respective outputs (O0 ... O3) are assigned fixedly.

Bit0 = least significant Bit

Layout of the status word 2 (Object 1000.4 (see on page 157))

Bit	Description
Bit0 ... 14	reserved
Bit15	Reg detected

Bit0 = least significant Bit

4.1.10. Encoder simulation

You can make use of a permanently integrated encoder simulation feature to make the actual position value available to additional servo drives or other automation components.

Caution! The encoder simulation is not possible at the same time as the encoder input resp. the step/direction input.
In both cases the same interface is used.

Simulated Encoder Output Resolution

Unit: Increments per revolution / pitch	Range: 4 - 16384	Standard value: 1024
Adjustable in powers of two (2 ⁿ): 1, 2, 4, 8, 16, 32, 64, 128, 256, 512, 1024, 2048, 4096, 8192, 16384		
Limit frequency: 620kHz i. e.		
Increments per revolution	Max. speed	
1024	36000 rpms	
4096	9000 rpms	
16384	2250 rpms	

4.1.10.1 Encoder bypass with Feedback module F12 (for direct drives)

If an encoder is used as feedback (with option F12), the encoder signals can be placed directly (Bypass) to the encoder interface (X11: same assignment as encoder simulation) for further use.

The advantage is that the limit frequency of the encoder simulation is avoided.

4.1.11. Absolute / Relative positioning

Operating mode: Absolute mode or continuous mode

Absolute mode A fixed measuring system is associated with the travel range: A fixed defined zero point exists. All positions are referred to this zero point.

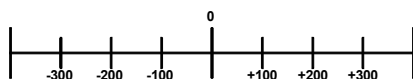

Continuous mode The actual position is set to 0 before each positioning. Thus the travel range has no fixed zero point. All positionings are relative - in relation to the actual position.

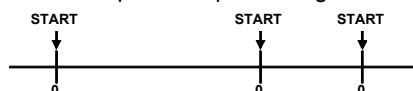

4.1.12. Defining the STOP function

The function "no STOP" is configurable.

No Stop: Input I1 and M.I6 resp. CW.1 and CW.14

STOP with termination

STOP and terminate the current positioning

A new START does not continue the positioning at the interruption point.

The motion set address is read in new and the motion set is executed completely.

Example: before the new START the motion set address "Pos x+1" is created.

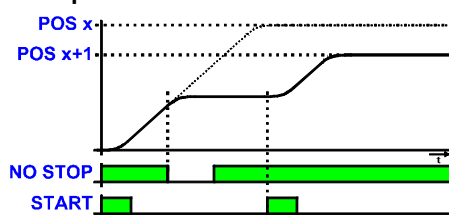

NO STOP: no STOP

START: START signal (on edge)

STOP without termination

STOP and interruption of the current positioning procedure.

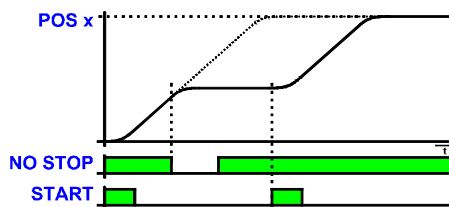

NO STOP: no STOP

START: START signal (on edge)

A new START resumes the positioning process at the position where it was interrupted.

4.1.13. Reg-related positioning / defining ignore zone

These settings are only required in connection with the function “reg-related positioning”

Within the reg window a reg signal will be ignored.

The reg window is defined by

- ◆ beginning of the ignore zone and
- ◆ End of the ignore zone

Beginning and end of the ignore zone are absolute values and therefore are also valid with negative position values.

This reg window is valid for all reg position sets.

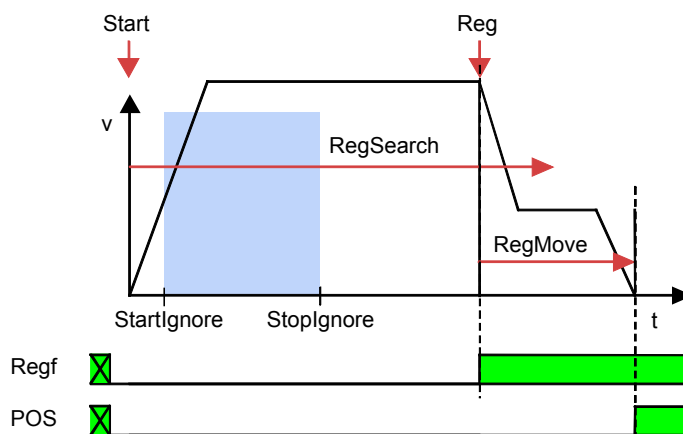

Start	Start signal for reg positioning
RegSearch:	Positioning for reg search
RegMove:	Positioning according to reg
Startignore:	Reg window: Beginning of the ignore zone
Stopignore:	Reg window: End of the ignore zone
Reg:	Reg signal
Regf	Signal: Reg detected (status word 2 Bit15 (Signal via PSBs with I/O control))
POS:	Signal: Position reached (Output O1: X12/3 or status word 1 Bit 9)

4.1.14. Write into set table

The motion sets are stored in a set table.

The table rows define always one motion set, in the columns the respective motion parameters of a motion set are stored.

	Motion parameters				
Machine reference run					
Set 1					
Set 2					
...					
Set 31					

Detailed description (see page 137).

31 motion sets are possible.

The motion set to be executed is selected via:

◆ Compax3 inputs (with control via I/Os)

or

◆ via the control word (with control via RS232 / RS285).

For the motion sets different motion functions with different motion parameters are available:

- ◆ **Empty:** empty motion set
- ◆ **MoveAbs (see on page 104)** absolute positioning
- ◆ **MoveRel (see on page 104)** relative Positioning
- ◆ **Gearing (see on page 109)** electronic gearbox
- ◆ **RegSearch (see on page 105):** Registration mark-related positioning (uses 2 motion sets: RegSearch and RegMove)
- ◆ **Velocity (see on page 110):** velocity control
- ◆ **Stop:** Stop movement

For each motion set you can define programmable status bits (PSBs), which will then be put out after the termination of the motion set.

Machine reference run

A start signal at address = 0 (motion set 0) triggers a machine zero run.

If the homing mode is active, there will always be a **homing run** (see on page 102) with the first start after each configuration download (with the aid of the C3 ServoManager).

4.1.14.1 Programmable status bits (PSBs)

The successful execution of a motion set can be queried via the PSBs.

PSBs:

- ◆ with control via I/Os:
3 outputs of the I/O option (M10 or M12) M.O9, M.O10, M.O11

or

- ◆ with control via RS232 / RS485:
Status word Bit 13, Bit 14, Bit 15

Definition of the pattern:

The settings for the PSBs are made in the respective motion set

You can set 3 assignments for the respective bits:

- X: No change Output / Bit is not influenced
- 0: Inactive Output / Bit is set to 0
- 1: Active Output / Bit is set to 1 resp. 24VDC

Storage of the **PSBs** (see on page 137).

Programmable status bits (PSBs)

The successful execution of a motion set can be queried via the PSBs.

PSBs: Bit 12, 13 and 14 of status word 2.

4.1.14.2 Set selection

Set number: Address of the positioning data record.

The address results from the binary value of the inputs:

I/O control	RS232 / RS485 control control word	Values
M.I0	Bit 8	$2^0 = 1$
M.I1	Bit 9	$2^1 = 2$
M.I2	Bit 10	$2^2 = 4$
M.I3	Bit 11	$2^3 = 8$
M.I4	Bit 12	$2^4 = 16$

4.1.14.3 MoveAbs and MoveRel

A motion set defines a complete motion with all settable parameters.

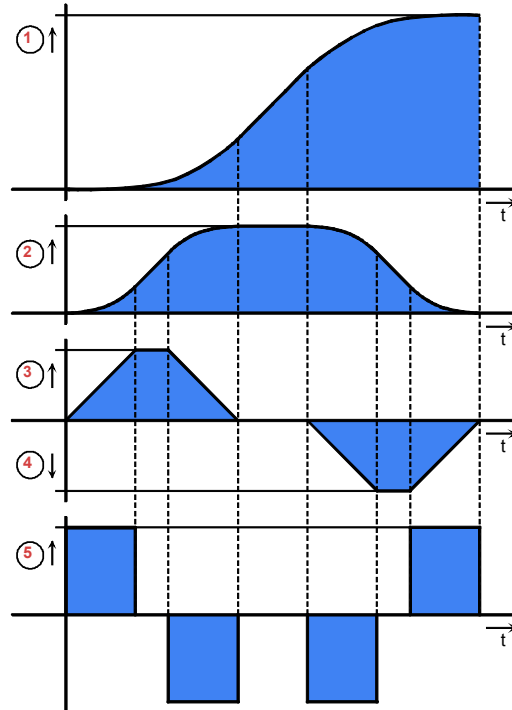

- 1: Target position
- 2: Travel speed
- 3: Maximum acceleration
- 4: Maximum deceleration (delay)
- 5: Maximum **jerk** (see on page 87)

Motion functions **MoveAbs:** Absolute positioning.
MoveRel: Relative positioning

Target position / distance Target position in the chosen unit
Distance at MoveRel

Speed Speed in length unit/s

Acceleration Acceleration in Unit/s²

Deceleration Deceleration in Unit/s²

Jerk Jerk in unit/s³

4.1.14.4 Reg-related positioning (RegSearch, RegMove)

For registration mark-related positioning, 2 motions are defined.

RegSearch Search movements: Relative positioning in order to search for an external signal - of a reg
This may, for example, be a reg on a product.

RegMove The external signal interrupts the search movement and the second movement by the predefined offset follows without transition. The drive comes to a standstill at the position of the mark signal + the configured offset.

Exactitude of the reg detection: < 1 μs

Example 1: Reg comes after the reg restriction window

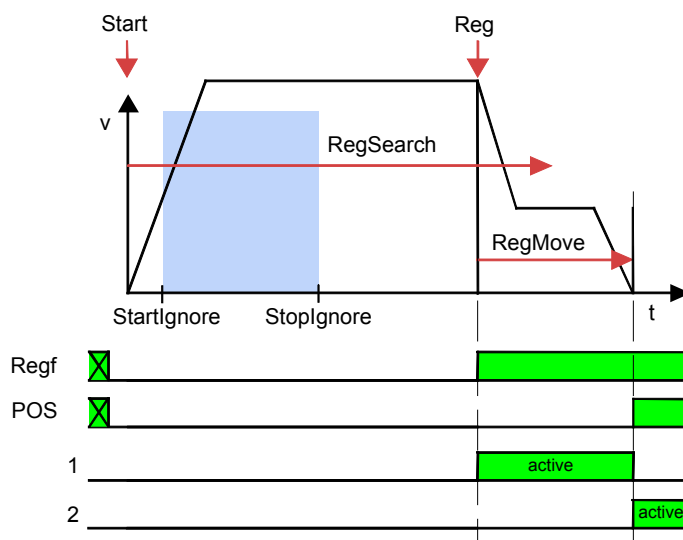

- Start** Start signal for the reg-related positioning (M.15 on X22/13 or CW.13)
- RegSearch:** Positioning for reg search
- RegMove:** Positioning according to reg
- StartIgnore:** **Reg ignore window:** (see on page 101) beginning of the ignore window
- StopIgnore:** Reg ignore window: End of the ignore zone
- Reg:** Reg signal (I4 on X12/10)
- Regf:** Signal: Reg detected (status word 2 Bit15 (Signal via PSBs with I/O control))
- POS:** Signal: Position reached (Output O1: X12/3 or status word 1 Bit 9)
- 1** Programmable status bits of RegSearch
- 2** Programmable status bits of RegMove

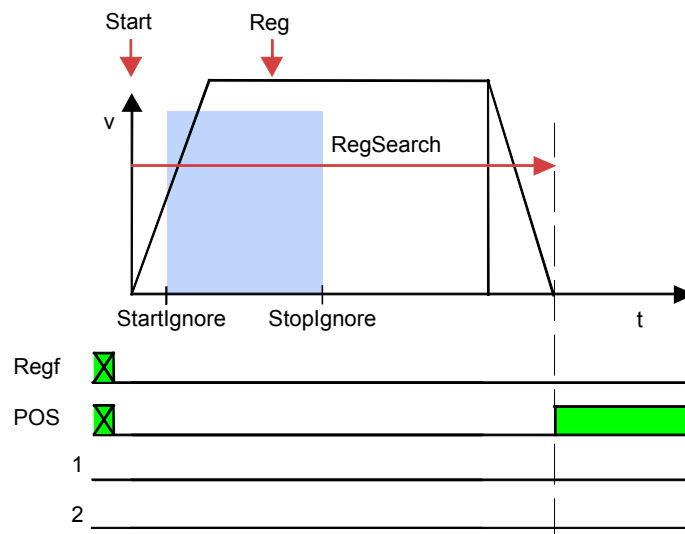
Example 2: Reg within the reg restriction window

Start	Start signal for the reg-related positioning (M.I5 on X22/13 or CW.13)
RegSearch:	Positioning for reg search
RegMove:	Positioning according to reg
StartIgnore:	Reg ignore window: (see on page 101) beginning of the ignore window
StopIgnore:	Reg ignore window: End of the ignore zone
Reg:	Reg signal (I4 on X12/10)
Regf:	Signal: Reg detected (status word 2 Bit15 (Signal via PSBs with I/O control))
POS:	Signal: Position reached (Output O1: X12/3 or status word 1 Bit 9)
1	Programmable status bits of RegSearch
2	Programmable status bits of RegMove

The reg is ignored; the drive moves to the target position from the RegSearch motion set.

Example 3: Reg is missing or comes after termination of the RegSearch motion set

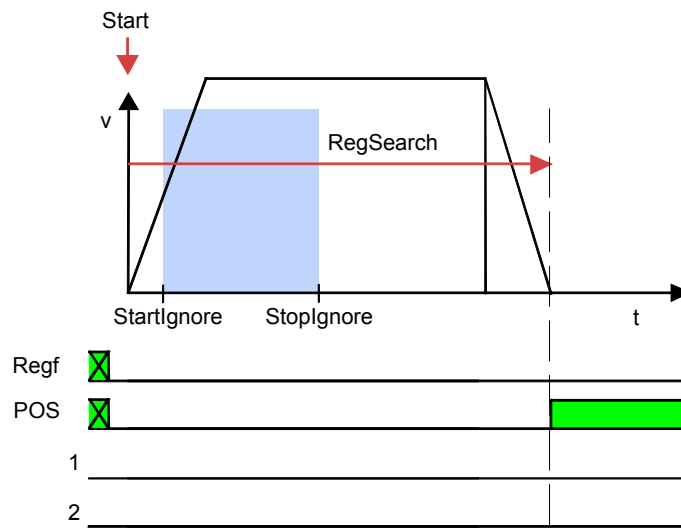

- Start** Start signal for the reg-related positioning (M.I5 on X22/13 or CW.13)
- RegSearch:** Positioning for reg search
- RegMove:** Positioning according to reg
- StartIgnore:** **Reg ignore window:** (see on page 101) beginning of the ignore window
- StopIgnore:** Reg ignore window: End of the ignore zone
- Reg:** Reg signal (I4 on X12/10)
- Regf:** Signal: Reg detected
(status word 2 Bit15 (Signal via PSBs with I/O control))
- POS:** Signal: Position reached
(Output O1: X12/3 or status word 1 Bit 9)
- 1** Programmable status bits of RegSearch
- 2** Programmable status bits of RegMove

The drive moves to the target position from the RegSearch motion set

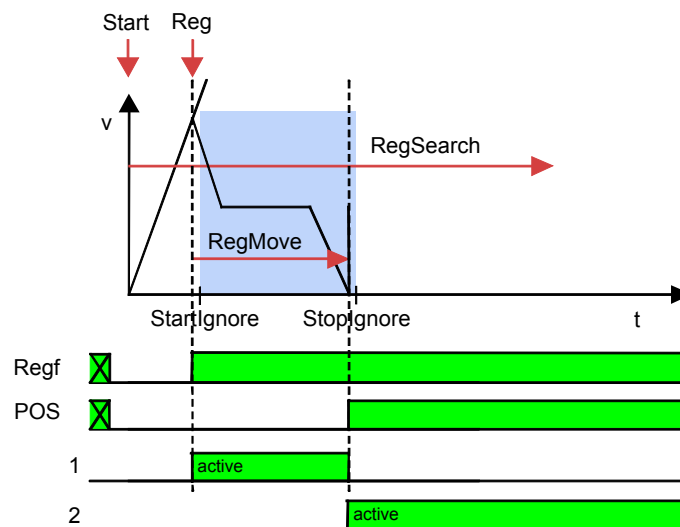
Example 4: Reg comes before the reg restriction window

Start	Start signal for the reg-related positioning (M.15 on X22/13 or CW.13)
RegSearch:	Positioning for reg search
RegMove:	Positioning according to reg
Startignore:	Reg ignore window: (see on page 101) beginning of the ignore window
Stopignore:	Reg ignore window: End of the ignore zone
Reg:	Reg signal (I4 on X12/10)
Regf:	Signal: Reg detected (status word 2 Bit15 (Signal via PSBs with I/O control))
POS:	Signal: Position reached (Output O1: X12/3 or status word 1 Bit 9)
1	Programmable status bits of RegSearch
2	Programmable status bits of RegMove

As from the mark, the drive moves on relatively by the offset defined in RegMove and then stops at that position (same behavior as in example 1).

Please note:

The reg restriction window is the same for all reg motion sets!

4.1.14.5 Electronic gearbox (Gearing)

The motion function “Gearing” (electronic gearbox) moves Compax3 synchronously with a leading axis.

A 1:1 synchrony or any transmission ratio can be selected via the gear factor. A negative sign – which means reversal of direction – is permitted.

Function Electronic gearbox (Gearing)

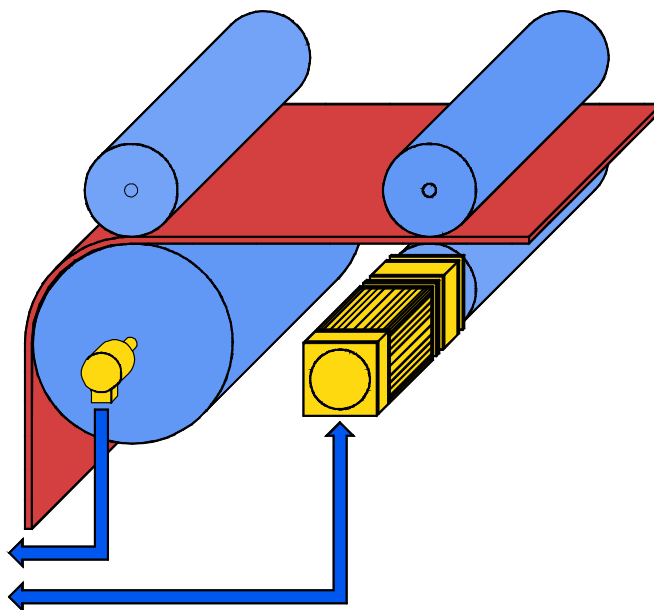

The position of a master axis can be detected via:

- ◆ +/-10V analog input
- ◆ Step / direction input (X11/6, 7, 8, 12)
- ◆ the encoder input (X11/6, 7, 8, 12) or
- ◆ HEDA, if Compax3 is used as master drive.

The master signal detection is configured under synchronization.

Settings of the “Gearing” motion function

Gearing numerator / Gearing denominator:

Transmission ratio slave / master

The transmission ratio (gear factor) can be entered in “Gearing numerator” (at “Gearing denominator” = 1).

You will obtain an exact image of a non-integral transmission ratio by entering the value integrally as a fraction with numerator and denominator. This helps to avoid long-term drifts

The rule for this is:

$$\frac{\text{Slave}}{\text{Master}} = \frac{\text{Gearing numerator}}{\text{Gearing denominator}}$$

Acceleration

Here you can define the acceleration for the drive to reach the desired synchrony.

- Dynamic change of the gear factor** You can switch dynamically between 2 gearing motion sets with different gear factors.
The set acceleration counts as deceleration if the gear factor is reduced.
- Dynamic switching between the Gearing motion function and other motion functions is not possible.
- Synchronicity:** The signal "Gear reached" (Output O1:X12/3 resp. status word 1 Bit 9) shows that the synchronicity has been reached.
The signal "Gear reached" is reset if the synchronicity is exited.
The programmable status bits (PSBs) are activated via the signal "Gear reached"
- Limiting effects** If the synchronicity is lost temporarily due to limitations, the resulting position difference is made up afterwards.
- Note:** Jerk is not limited.

4.1.14.6 Speed specification (Velocity)

This motion function is defined by velocity and acceleration.

An active motion set is interrupted by:

- ◆ Stop or
- ◆ Start of a different set.

As soon as the setpoint speed is reached, "speed reached" (Output O1: X12/3 or status word 1 Bit 9) as well as the defined status bits (PSBs) are activated.

- Note:** Position control is active, i.e. the following error caused by limitations will be made up.
Jerk is not limited.

4.1.14.7 Stop command (Stop)

The Stop set interrupts the current motion set (Stop with interruption).

This motion function is defined by the deceleration and the jerk of the drive when coming to a standstill.

As soon as the drive is at a standstill, "Position reached" (Output O1:X12/3 or status word 1 bit 9) as well as the defined status bits (PSBs) are activated.

- Note:** The stop command (as motion function) is not effective during the machine zero run.

4.1.15. Dynamic positioning

You can change over to a new motion set during a positioning process.

Thereby the following conditions apply:

- ◆ Acceleration and deceleration remain constant independent of the values predefined in the new motion set.
- ◆ The jerk, too, remains constant.
- ◆ The velocity of the new motion set is activated.
- ◆ The drive moves to the target position defined in the new motion set.
- ◆ The new motion set address must not equal 0.

Example: MoveAbs (Target position POS1) is interrupted by a new MoveAbs with target position (POS 5)

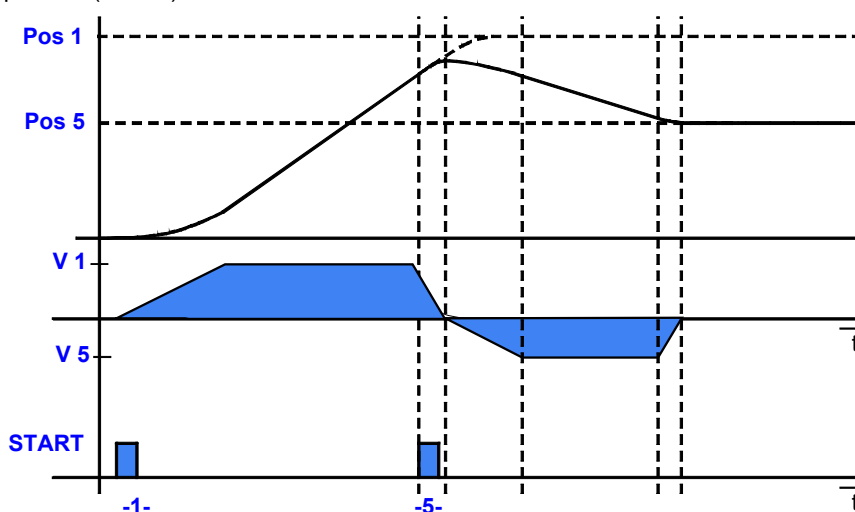

The following dynamic transitions are supported:

Motion function in progress	Possible dynamic change to the motion function:
MoveAbs, MoveRel, RegSearch, RegMove, Velocity	MoveAbs, MoveRel, Velocity, RegSearch, Gearing
Gearing	Gearing (other gear factor)
Stop	-

4.1.16. RS485 setting values

If "Master=Pop" was selected, only the settings compatible with the Pops (Parker Operator Panels) made by Parker are possible.

Please note that the connected Pop has the same RS485 setting values.

You can test this with the "PopDesigner" software.

"Master=General" makes all Compax3 settings possible.

- Multicast Address** You can use this address to allow the master to access multiple devices simultaneously.
- Device Address** The device address of the connected Compax3 can be set here.
- Baud rate** Adjust the transfer speed (baud rate) to the master.
- Connection Type** Please choose between **two wire and four wire – RS485** (see on page 31).
- Protocol** Adjust the protocol settings to the settings of your master.

4.1.17. Configuration name / comments

Here you can name the current configuration as well as write a comment.

4.2 Optimization

In this chapter you can read about:

Control Loop Dynamics	113
Input simulation	120
Calibration of the analog input	121
Commissioning mode	122
Turning the motor holding brake on and off	123

The controller optimization of the Compax3 is carried out in 2 steps:

- ◆ Via the standard settings (stiffness, damping, rotation speed controller and rotation speed filter), with the help of which many applications can be optimized in a simple manner.
- ◆ With advanced settings for users familiar with control loops.

4.2.1. Control Loop Dynamics

In this chapter you can read about:

Velocity loop stiffness	114
Velocity loop damping	115
Velocity Filter	115
Advanced control parameters	116

4.2.1.1 Velocity loop stiffness

The stiffness is proportional to the control loop speed.

Nominal value: 100%

On increasing stiffness:

Control action becomes faster. The control loop oscillates above a critical threshold value. Set the stiffness with an adequate safety margin with respect to the oscillation threshold value.

On decreasing stiffness:

Control action becomes slower. This increases the following error. Current limiting will be reached later.

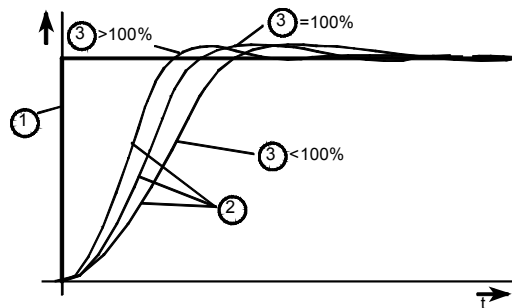

1: Setpoint value

2: Actual value

3: Stiffness

2100.2: Velocity loop stiffness

Unit: %	Range: 10 ... 100 000	Standard value: 100%
---------	-----------------------	----------------------

The stiffness is proportional to the control loop speed.
--

4.2.1.2 Velocity loop damping

The damping influences the Setpoint value overshoot magnitude and the decay time constant of control loop oscillation.

Nominal value: 100%

On increasing the damping:

Overshoot decreases. High frequency oscillation of the servo drive takes place as from a certain threshold value.

On decreasing the damping:

The Setpoint value overshoot of the actual value increases, and the actual value oscillates for a longer time above and below the Setpoint value. As from a certain threshold value the servo drive oscillates continuously.

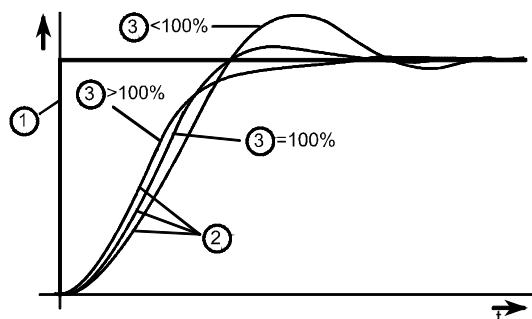

- 1: Setpoint value
- 2: Actual value
- 3: Damping

2100.3: Velocity loop damping

Unit: %	Range: 0 ... 500	Standard value: 100%
The damping influences the Setpoint value overshoot magnitude and the decay time constant of control loop oscillation.		

4.2.1.3 Velocity Filter

Can be used to improve (filter) the rotation speed signal. The greater the value, the stronger becomes the filter effect. However, the rotation speed delay increases with this value, so that the maximum possible control loop dynamic range becomes smaller with values which are too large.

- ◆ Set the value to 0 when using motors with SinCos.
- ◆ In the case of large load inertia in relation to the moment of inertia of the motor, a large value can achieve further improvement in the attainable stiffness.

2100.5: Velocity Filter

Unit: %	Range: 0 ... 550	Standard value: 100%
This is used to improve signals (filtering) of the speed control signal		

4.2.1.4 Advanced control parameters

Controller structure:

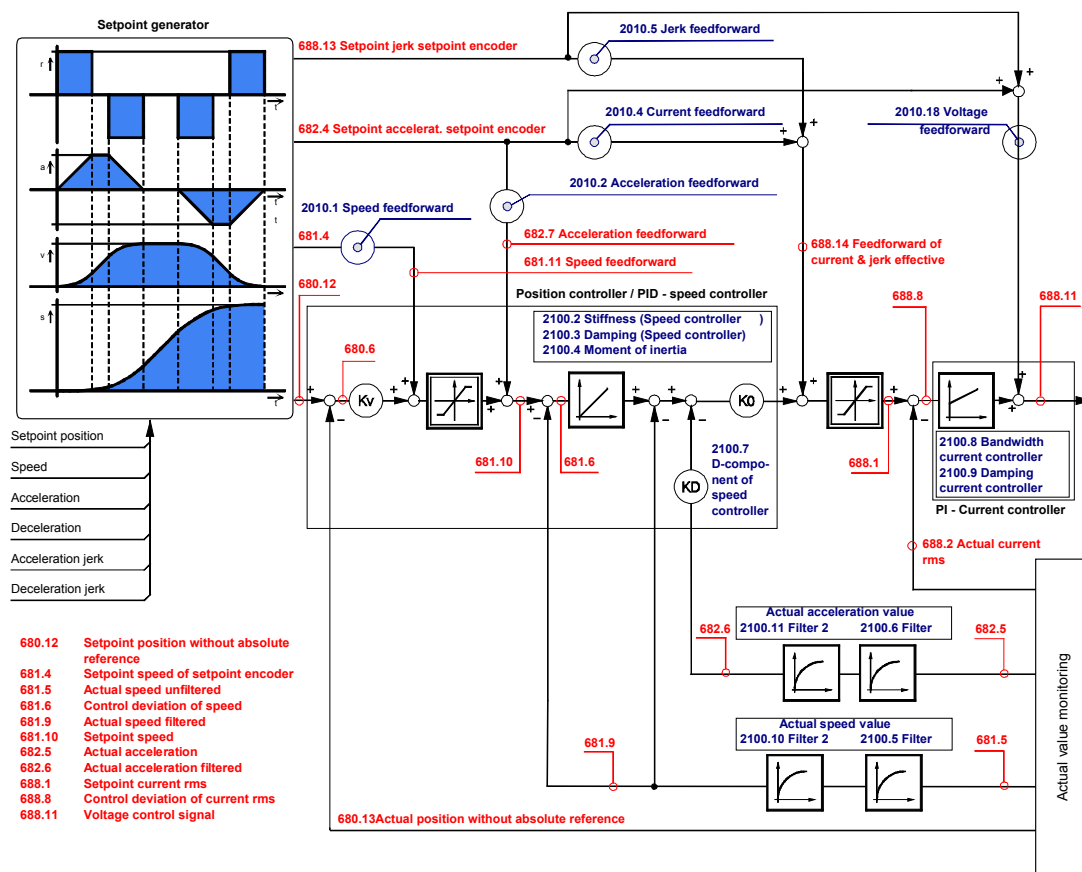

The status values are divided into 2 groups (user levels):

standard: here you can find all important status values

advanced: advanced status values, require a better knowledge

Switching of the user level

The user level can be changed in the optimization window (left hand side lower part under selection (TAB) "optimization") with the following button.



2100.8: Current Loop Bandwidth

Unit: %	Range: 10 ... 200	Standard value: 50%
---------	-------------------	---------------------

2100.9: Current Loop Damping

Unit: %	Range: 0 ... 500	Standard value: 100%
---------	------------------	----------------------

2100.7: Velocity Loop - "D" Term

Unit: %	Range: 0 ... 4 000 000	Standard value: 0
---------	------------------------	-------------------

2100.6: Actual Acceleration Filter

Unit: %	Range: 0 ... 550	Standard value: 100
---------	------------------	---------------------

2100.4: Moment of Inertia

Unit: %	Range: 10 ... 500	Standard value: 100%
---------	-------------------	----------------------

Forward control measures

Feedforward of rotation speed, acceleration and current

- Advantages:**
- ◆ Minimizes following error
 - ◆ Improves the transient response
 - ◆ Gives greater dynamic range with lower maximum current

Principle: A positioning is calculated in the Setpoint value plate and specified as the Setpoint value for the position controller. This provides the Setpoint value plate with the preliminary information on changes in speed, acceleration and current required for positioning. Switching this information to the controller then makes it possible to reduce tracking errors to a minimum. The transient response of the controller is also improved and the drive dynamics are increased.

The stability of the control loop is unaffected by the forward control.

Positioning without forward control:

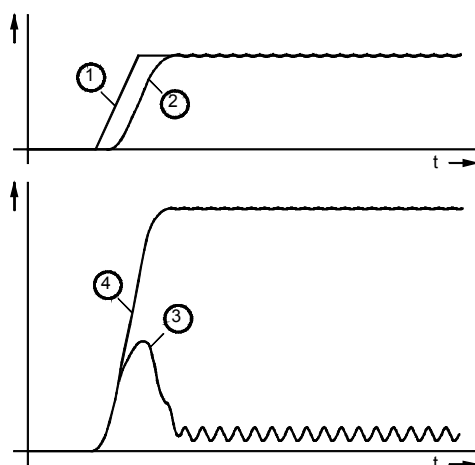

2010.1: Velocity feedforward

Unit: %	Range: 0 ... 500	Standard value: 100%
---------	------------------	----------------------

Effect of the rotation speed forward control

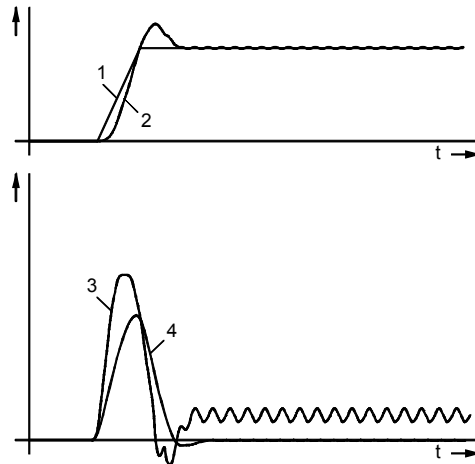

- 1: Setpoint speed value
- 2: Actual speed value
- 3: Motor current
- 4: Tracking error

2010.2: Acceleration feedforward

Unit: %	Range: 0 ... 500	Standard value: 100%
---------	------------------	----------------------

Additional effect of forward acceleration control

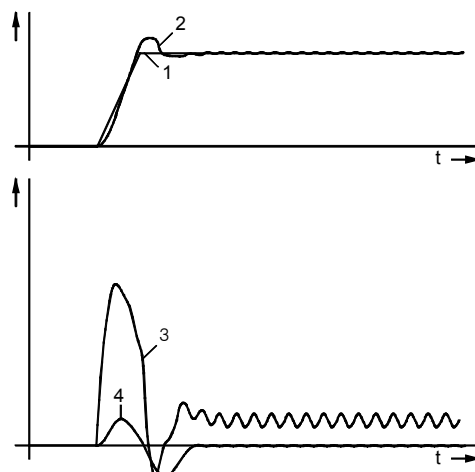

- 1: Setpoint speed value
- 2: Actual speed value
- 3: Motor current
- 4: Tracking error

2010.4: Current feedforward

Unit: %	Range: 0 ... 500	Standard value: 0%

Additional effect of current feedforward

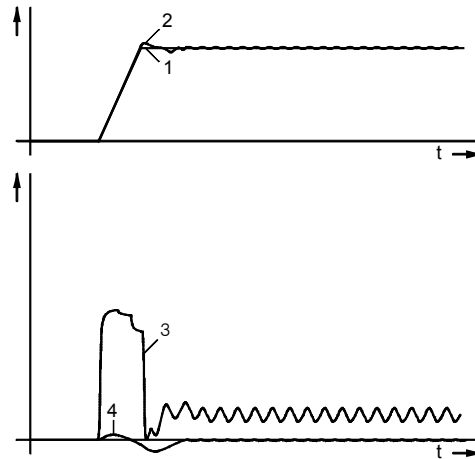

- 1: Setpoint speed value
- 2: Actual speed value
- 3: Motor current
- 4: Tracking error

2010.5: Jerk feedforward

Unit: %	Range: 0 ... 500	Standard value: 0%

4.2.2. Input simulation

In this chapter you can read about:

Calling up the input simulation	120
Functionality	121

Function The input simulation is used for the performance of tests without the complete input/output hardware being necessary.

The digital inputs (standard and inputs of M10/M12 option) as well as the analog inputs are supported.

The following operating modes are available for digital inputs:

- ◆ The physical inputs are deactivated, the digital inputs are only influenced via the input simulation.
- ◆ The digital inputs and the physical inputs are logically or-linked. This necessitates very careful action, as the required function is, above all with low-active signals, no longer available.

The pre-setting of an analog input value is always made in addition to the physical analog input.

the function of the inputs depends on the Compax3 device type; please refer to the respective online help or the manual.

The input simulation is only possible while the connection with Compax3 is active!

4.2.2.1 Calling up the input simulation

Open the optimization window (double click in the C3 ServoManager tree entry: Optimization).

Activate the Tab "Setup" in the right lower window.

Clicking on the following button will open a menu; please select the input simulation.



4.2.2.2 Functionality

Window Compax3 InputSimulator:

1. row: Standard Inputs E7 ... E0 = "0" button not pressed; = "1" switch pressed

2. row: Optional digital inputs (M10 / M12)

Green field: port 4 is defined as input

Red field: port 4 is defined as output

the least significant input is always on the right side

3. row: if the button "deactivating physical inputs" is pressed, all physical, digital inputs are deactivated; only the input simulation is active.

If both sources (physical and simulated inputs) are active, they are or-linked!



Caution!

Please consider the effects of the or-linking; above all on low-active functions.

4. row: Simulation of the analog inputs 0 and 1 in 100mV – steps.

The set value is added to the value on the physical input.

After the input simulation has been called up, all simulated inputs are on "0".

When the input simulation is left, the physical inputs become valid.

4.2.3. Calibration of the analog input

In this chapter you can read about:

Offset alignment.....	121
Gain alignment.....	122

4.2.3.1 Offset alignment

Performing an offset alignment when working with the ±10V analog interface in the optimization window under optimization: Analog Input.

Enter the offset value at 0V input voltage under "701: Offset"

The currently entered value is shown in the status value "analogue input" (optimizing window at the top right) (unit: 1 ≙ 10V). Enter this value directly with the same sign as offset value.

The status value "analogue input" shows the corrected value.

4.2.3.2 Gain alignment

Performing an offset alignment when working with the $\pm 10V$ analog interface in the optimization window under optimization: Analog Input: 702: Gain.

A gain factor of 1 has been entered as default value.

The currently entered value is shown in the status value "analogue input" (optimising window at the top right).

The status value "analogue input" shows the corrected value.

4.2.4. Commissioning mode

Setup mode can be activated in the ServoManager under the menu item "Optimization".

The following functions are possible:

- ◆ Machine reference run
- ◆ Jog+ / Jog-
- ◆ Activation / deactivation of the motor holding brake.
- ◆ Acknowledging errors
- ◆ Defining and activating a test movement
- ◆ Activating the digital outputs.

In setup mode, access via interface and via digital inputs is deactivated.

4.2.5. Turning the motor holding brake on and off

Compax3 controls the holding brake of the motor and the power output stage. The time behavior can be set.

Application:

For an axis to which torque is applied in the stationary state (e.g. for a z-axis) the drive can be switched on and off in a manner such that no load movement takes place. The drive thereby remains energized during the holding brake response time. This is adjustable.

The power output stage current is de-energized by:

- ◆ Error or
- ◆ I2=X12/8="0V"

Thereafter the motor is braked to zero rotation speed on the set ramp.

When zero speed is reached, the motor is de-energized with the delay "brake closing delay time".

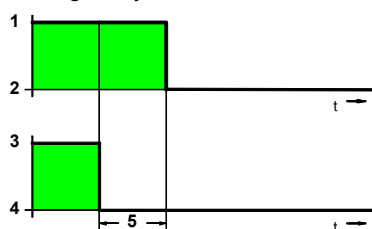

- 1: Motor powered
- 2: Motor de-energized
- 3: Brake open
- 4: Engage the brake
- 5: brake closing delay time

The power output stage is enabled by:

- ◆ Quit (after an error)
- ◆ I2=X12/8 = 24V

The motor is energized with the delay "delay time for brake release".

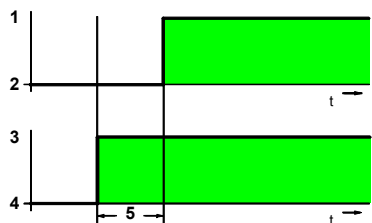

- 1: Motor powered
- 2: Motor de-energized
- 3: Brake open
- 4: Engage the brake
- 5: Delay time for brake release

4.3 Select signal source for Gearing

In this chapter you can read about:

Signal source HEDA	125
Encoder A/B 5V or step/direction as signal source	125
+/-10V analog speed setpoint value as signal source	127

Here the signal source is configured for the motion function "Gearing" (electronic gearbox).

Available are:

Gearing input signal source

- ◆ The HEDA real-time bus (M10 or M11 option) directly from a Compax3 master axis
- ◆ an encoder signal A/B 5V
- ◆ a step/direction signal 5V or
- ◆ a velocity as analog value +/-10V

HEDA operating mode HEDA as Master

If an existing HEDA option (M10 or M11) is not used as signal source, you can transmit the following signals for a slave axis via HEDA:

- ◆ Process setpoint position
- ◆ Process actual position
- ◆ Position from external setpoint

Signal read in via analog output 0, encoder input or step / direction input in the master.

Principle:

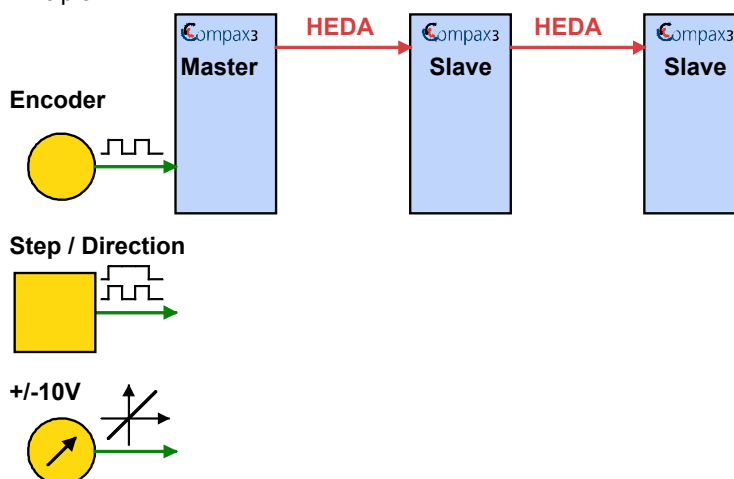

**Attention in the case of a configuration download with master-slave coupling (electronic gearbox, cam)**

Switch Compax3 to currentless before starting the configuration download: Master and Slave axis

4.3.1. Signal source HEDA

Signal source is a Compax3 master axis in which the HEDA operating mode "HEDA master" is set.

Please enter besides the desired error reaction an individual HEDA axis address in the range from 1 ...32.

The dimensional reference to the master is established via the following settings:

- ◆ Travel distance per motor revolution master axis numerator with denominator = 1 the value can be entered directly. Long-term drift can be avoided by entering non-integral values integrally as a fraction with numerator and denominator.

- ◆ Travel distance per motor revolution master axis denominator

If required the direction of rotation of the master axis read in can be changed.

4.3.2. Encoder A/B 5V or step/direction as signal source

Caution! The encoder simulation is not possible at the same time as the encoder input resp. the step/direction input.

In both cases the same interface is used.

The dimensional reference to the master is established via the following settings:

- ◆ Travel distance per motor revolution master axis numerator with denominator = 1 the value can be entered directly. Long-term drift can be avoided by entering non-integral values integrally as a fraction with numerator and denominator.

- ◆ Travel distance per motor revolution master axis denominator

- ◆ Increments per revolution of the master axis

If required the direction of rotation of the master axis read in can be changed.

4.3.2.1 Example: Electronic gearbox with position detection via encoder

Reference to master axis The reference to the master axis is established via the increments per revolution and the travel path per revolution of the master axis (corresponds to the circumference of the measuring wheel).

The rule for this is:

$$\text{MasterPos} = \frac{\text{Master_I}}{\text{I_M}} * \frac{\text{Travel Distance per Master Axis revolution (M_Units/rev)}}{\text{Travel Distance per Master Axis revolution - Denominator}} \quad (1)$$

MasterPos: Master position

Master_I: master increments read in

I_M: Increments per revolution of the master axis

External signal source Encoder with 1024 increments per master revolution and a circumference of the measuring wheel of 40mm.

Synchronization wizard: Travel path per revolution of the master axis numerator = 40
 Travel path per revolution of the master axis denominator = 1
 Increments per revolution of the master axis = 1024

Configuration wizard: Reference system of Slave axis: Unit of measure [mm]
 Travel path per revolution numerator = 1
 Travel path per revolution denominator = 1

Gearing: Gearing numerator = 2
 Gearing denominator = 1

This results in the following interrelations:

If the measuring wheel moves by 40mm (1 master revolution), the slave axis will move by 80mm.

$$\text{Slave unit} = \text{MasterPos} * \frac{\text{Gearing numerator}}{\text{Gearing denominator}} \quad (2)$$

(1) set into (2) and with numerical values results with 1024 increments read in (=1 Master revolution):

$$\text{Slave unit} = 1024 * \frac{1}{1024} * \frac{40\text{mm}}{1} * \frac{2}{1} = 80\text{mm}$$

Master - Position = +40mm => Slave - Position = +80mm

Structure:

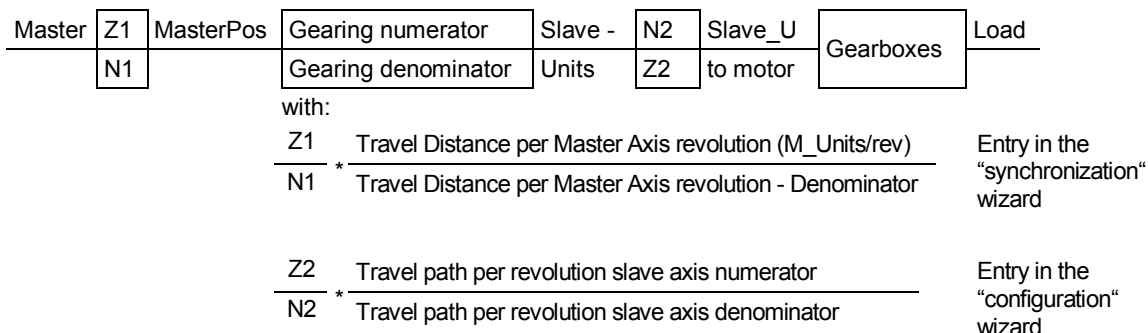

4.3.3. +/-10V analog speed setpoint value as signal source

The velocity of the master is read in via the analog channel 0 (X11/9 and X11/11). From this value a position is internally derived, from which then the motion of the drive is derived with reference to the transmission ratio.

Without limitation effect applies:

Velocity of the master * (Gearing numerator / gearing denominator) = velocity of the slave

The reference to the master is established with the velocity at 10V.

If required the direction of rotation of the master axis read in can be changed.

4.3.3.1 Time frame signal source master

Averaging and a following filter (interpolation) can help to avoid steps caused by discrete signals.

If the external signal is analog, there is no need to enter a value here (Value = 0). For discrete signals e.g. from a PLC, the scanning time (or cylice time) of the signal source is entered.

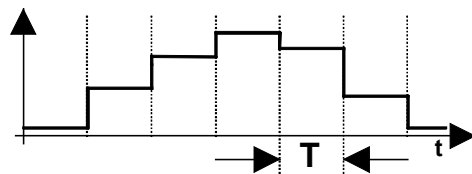

This function is only available if the analog interface +/-10V is used!

5. Control via RS232 / RS485

In this chapter you can read about:

Status diagram	129
I/O assignment, control word and status word with control via RS232 / RS485	131
Examples: Control via RS232 / RS485	135
Layout of the set table	137
RS232 & RS485 – interface record	139
Compax3 - Objects	145
Description of the interface protocol (see on page 139)	

5.1 Status diagram

Status diagram for control via RS232 / RS485

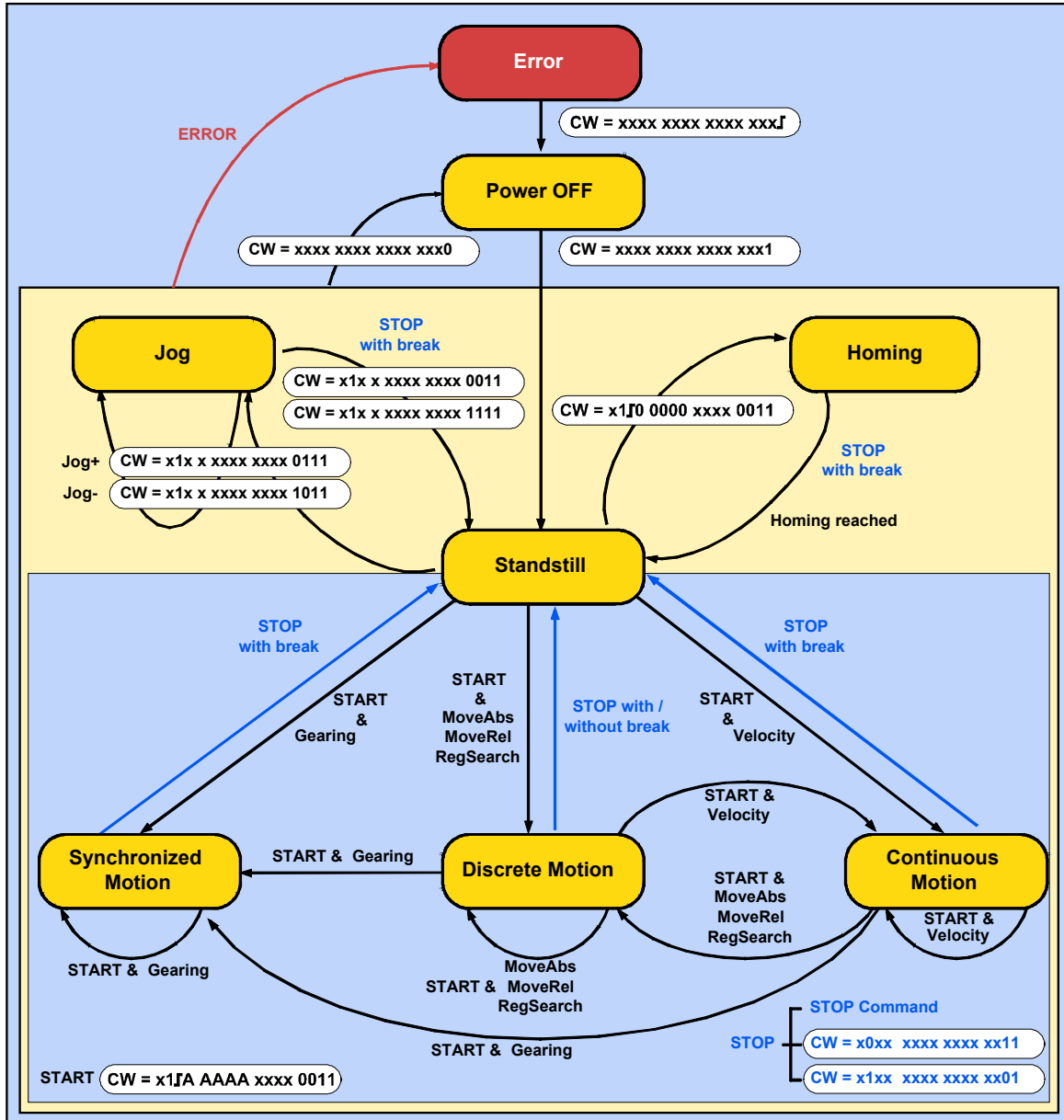

In the "Homing" and "Jog" states, no stop set (STOP command) is possible.

CW: Control word; bit counting method: Bit 0 on the right side

x: x: status of the respective bits without meaning

A: Set address

otherwise status 0, 1 or positive edge

Status values:	Description
ERROR	Error, drive currentless
Power OFF	Drive currentless and ready to operate
Jog	Manual operation; Manual+, Manual- possible
Homing	Machine zero run, status is exited automatically after the position 0 has been approached
Standstill	Drive stationary with current with setpoint value = 0
Synchronized Motion	Gearing – motion set active
Discrete Motion	Positioning mode
Continuous Motion	Velocity – motion set active

Permitted transitions:

Please find the possible transitions between states resp. the different motion functions in the status diagram:

Examples:

- ◆ In the “discrete motion“ status (drive executes a motion function) the motion functions MoveAbs, MoveRel, MoveStart, Velocity and Stop are possible with dynamic transition.
- ◆ In the Continuous Motion status, only a stop with termination (Stop with break) is possible.

5.2 I/O assignment, control word and status word with control via RS232 / RS485

- ◆ Control via RS232 / RS485 does not require an M option (M10 / M12).
- ◆ If an M option is available, 12 inputs/outputs (ports) are freely assignable. These can be configured as inputs or outputs by groups of four and be activated resp. read via **Object 121.2** (see page 147) and **Object 133.3** (see page 147).
- ◆ The signal inputs I4 ... I7 are fixedly assigned
If the respective functions are not required, these inputs can also be used for control purposes.
I5 and I6 can, for instance, be used as free inputs if the limit switch function is deactivated.

Assignment of the intra-device inputs and outputs



PIN X12	Input/output	High density/Sub D
1	O	+24VDC output (max. 400mA)
2	O0	No Error
3	O1	Position / velocity / gear synchronization reached (max. 100mA)
4	O2	No power output stage current (max. 100mA)
5	O3	Motor stationary with current, with setpoint 0 (max. 100mA)
6	I0="1":	Quit (positive edge) / Energize the motor The address of the current motion set is read in new.
	I0="0"	Motor deenergized with delay
7	I1	No stop
8	I2	JOG+
9	I3	JOG -
10	I4	Reg input
11	I	24V input for the digital outputs Pins 2 to 5
12	I5	Limitswitch 1
13	I6	Limitswitch 2
14	I7	Machine reference initiator
15	O	Gnd 24 V

All inputs and outputs have 24V level.

Maximum capacitive loading of the outputs: 50nF (max. 4 Compax3-inputs can be connected)

5.2.1. I/O Assignment

- ◆ Control via RS232 / RS485 does not require an M option (M10 / M12).
- ◆ If an M option is available, 12 inputs/outputs (ports) are freely assignable. These can be configured as inputs or outputs by groups of four and be activated resp. read via **Object 121.2** (see page 147) and **Object 133.3** (see page 147).
- ◆ The signal inputs I4 ... I7 are fixedly assigned
If the respective functions are not required, these inputs can also be used for control purposes.
I5 and I6 can, for instance, be used as free inputs if the limit switch function is deactivated.



Assignment of the intra-device inputs and outputs

PIN X12	Input/output	High density/Sub D
1	O	+24VDC output (max. 400mA)
2	O0	No Error
3	O1	Position / velocity / gear synchronization reached (max. 100mA)
4	O2	No power output stage current (max. 100mA)
5	O3	Motor stationary with current, with setpoint 0 (max. 100mA)
6	I0="1":	Quit (positive edge) / Energize the motor The address of the current motion set is read in new.
	I0="0"	Motor deenergized with delay
7	I1	No stop
8	I2	JOG+
9	I3	JOG -
10	I4	Reg input
11	I	24V input for the digital outputs Pins 2 to 5
12	I5	Limitswitch 1
13	I6	Limitswitch 2
14	I7	Machine reference initiator
15	O	Gnd 24 V

All inputs and outputs have 24V level.

Maximum capacitive loading of the outputs: 50nF (max. 4 Compax3-inputs can be connected)

For intra-device inputs I0 .. I3 as well as the outputs O0 ... O3 you can choose between fixed or free assignment.

With fixed assignment of the intra-device inputs I0 ... I3, the respective functions can either be triggered via the inputs or via RS232 / RS485.

The following rules apply:

- ◆ The motor is only energized if I0 = "1" AND control word Bit 0 = "1"
- ◆ Stop is active if, I1 = "0" OR Control word Bit 1 = "0"
- ◆ Manual+ and Manual- inputs and control word are OR - linked.

5.2.2. Control word

Layout of the control word (Object 1100.3 (see on page 156))

Bit	Function	Corresponds to *
Bit0	Quit (edge) / energize Motor	I0: X12/6
Bit1	No Stop	I1: X12/7
Bit2	Manual + (Timeout 500ms)	I2: X12/8
Bit3	Manual - (Timeout 500ms)	I3: X12/9
Bit4	O0 X12/2	(only if O0...O3 is defined as freely assignable)
Bit5	O1 X12/3	
Bit6	O2 X12/4	
Bit7	O3 X12/5	
Bit8	Address 0	
Bit9	Address 1	
Bit10	Address 2	
Bit11	Address 3	
Bit12	Address 4	
Bit13	Start (edge)	
Bit14	No Stop (2nd Stop)	
Bit15	Brake open	

* does only apply if the respective inputs are assigned fixedly.

Bit0 = least significant Bit

5.2.3. Status word 1 & 2

Layout of the status word 1 (Object 1000.3 (see on page 157))

Bit	Description	Corresponds to *
Bit0	I0	X12/6
Bit1	I1	X12/7
Bit2	I2	X12/8
Bit3	I3	X12/9
Bit4	I4	X12/10
Bit5	I5	X12/11
Bit6	I6	X12/12
Bit7	I7	X12/13
Bit8	No Error	X12/2
Bit9	Position reached	X12/3
Bit10	Motor de-energized	X12/4
Bit11	Motor stationary with current at setpoint value zero	X12/5
Bit12	Machine zero (home) Position known	
Bit13	Programmable status bit 0 (PSB0)	
Bit14	Programmable status bit 1 (PSB1)	
Bit15	Programmable status bit 2 (PSB2)	

* Does apply for Bit 8 ... 11 only if the respective outputs (O0 ... O3) are assigned fixedly.

Bit0 = least significant Bit

Layout of the status word 2 (Object 1000.4 (see on page 157))

Bit	Description	
Bit0 ... 14	reserved	
Bit15	Reg detected	

Bit0 = least significant Bit

5.3 Examples: Control via RS232 / RS485

In this chapter you can read about:

- ◆ Control via RS232 / RS485 is executed via the control word (object 1100.3) and the status word (object 1000.3).
- ◆ These examples are based on the ASCII record, they may, however, also be realized on the binary record. The binary record offers the advantage, that the transmission is ensured by the CRC verification.
- ◆ The commands can also be entered via a hyperterminal (terminal setting is 115200,8,N,1 with hardware flow control. Local echo and connection of CR/LF is recommended).
- ◆

Energizing the axis:

Command:	break	/Stop	Start	Addr4	Addr3	Addr2	Addr1	Addr0	O3	O2	O1	O0	Jog-	Jog+	/Stop	Quit / motor
o1100.3=1	0	0	0	0	0	0	0	0	0	0	0	0	0	0	0	1

Manual motion (manual+)

Command:	break	/Stop	Start	Addr4	Addr3	Addr2	Addr1	Addr0	O3	O2	O1	O0	Jog-	Jog+	/Stop	Quit / motor
o1100.3=\$4007	0	1	0	0	0	0	0	0	0	0	0	0	0	1	1	1

Approach machine zero

Command:	break	/Stop	Start	Addr4	Addr3	Addr2	Addr1	Addr0	O3	O2	O1	O0	Jog-	Jog+	/Stop	Quit / motor
o1100.3=\$4003	0	1	0	0	0	0	0	0	0	0	0	0	0	0	1	1

First of all was ensured, that Start is at 0, as a rising edge is required for triggering a motion.

Start - edge

Command:	break	/Stop	Start	Addr4	Addr3	Addr2	Addr1	Addr0	O3	O2	O1	O0	Jog-	Jog+	/Stop	Quit / motor
o1100.3=\$6003	0	1	1	0	0	0	0	0	0	0	0	0	0	0	1	1

Then the set is started with address 0 (=always reference run).

Clear Error

At first the errors can be read:

- o550.1 read last error
- o550.2 read last but one error
- ...

In the error history the executed error acknowledgements are also listed (value=1). This helps you to read out the errors that occurred since the last acknowledgement.

If the cause of an error is eliminated, the error can be acknowledged. To do this, you will need a rising edge on Bit 0.

Set ackn to "0"

Command:	break	/Stop	Start	Addr4	Addr3	Addr2	Addr1	Addr0	O3	O2	O1	O0	Jog-	Jog+	/Stop	Quit / motor
o1100.3=0	0	0	0	0	0	0	0	0	0	0	0	0	0	0	0	0

Ackn - edge

Command:	break	/Stop	Start	Addr4	Addr3	Addr2	Addr1	Addr0	O3	O2	O1	O0	Jog-	Jog+	/Stop	Quit / motor
o1100.3=\$4003	0	1	0	0	0	0	0	0	0	0	0	0	0	0	1	1

Read out status

The status word1 can be accessed via object 1000.3.

Command:

o1000.3

The address of the set executed last can be read out via status word2 object 1000.4:

o1000.4

Description of the set table

The set table can be written in either via the Compax3 ServoManager or directly via the RS232/485 communication.

Example:

Entry of a motion set in set 5.

- Motion set:**
- ◆ Absolute positioning on position 234,54
 - ◆ Velocity 21,4
 - ◆ Acceleration 200
 - ◆ Deceleration 500
 - ◆ Jerk maximum 10000
 - ◆ Programmable status bits:
 - ◆ PSB2 must remain unchanged
 - ◆ PSB1 = 1 and
 - ◆ PSB0 = 0.

The following commands are to be transmitted:

- o1901.5=234.54 Target position (column 1, row 5)
- o1902.5=21.4 Velocity (column 2, row 5)
- o1905.5=1 Mode=1 (MoveAbs)
- o1906.5=200 Accel
- o1907.5=500 Decel
- o1908.5=10000 Jerk

The control word for the control of the PSBs is made up as follows:

Bit 7	Bit 6	Bit 5	Bit 4	Bit 3	Bit 2	Bit 1	Bit 0	Value
-	Ena PSB2	Ena PSB1	Ena PSB0	-	PSB 2	PSB 1	PSB 0	
0	0	1	1	0	0	1	0	=\$32

Command for the entry into the set table:

o1904.5=\$32

Modifications of set parameters must be made before the start of the respective set.

After the start of the set, the parameters can be modified again, even if the respective set is not yet completed.

Changing the ignore zone

Changes of the ignore zone for registration search [RegSearch] can also be made via RS232. The following objects must be changed:

- o3300.8 Beginning of the ignore zone
- o3300.9 End of the ignore zone

The value for the beginning of the ignore zone must always be smaller than the value for the end of the ignore zone. Only positive values are to be entered.

5.4 Layout of the set table

The motion sets are memorized in an object table. The table has 9 columns and 32 rows.

A motion set is stored in a table row.

The assignment of the columns depends on the motion function.

General layout of the table:

	Column 1 type: REAL objects O1901	Column 2 type: REAL objects O1902	Column 3 type: INT objects O1903	Column 4 type: INT objects O1904	Column 5 type: INT objects O1905	Column 6 type: DINT objects O1906	Column 7 type: DINT objects O1907	Column 8 type: DINT objects O1908	Column 9 type: DINT objects O1909
Set 1	Row 1 "Array_Col 1_Row1" (1901.1)	Row 1 "Array_Col 2_Row1" (1902.1)	Row 1 "Array_Col 3_Row1" (1903.1)	Row 1 "Array_Col 4_Row1" (1904.1)	Row 1 "Array_Col 5_Row1" (1905.1)	Row 1 "Array_Col 6_Row1" (1906.1)	Row 1 "Array_Col 7_Row1" (1907.1)	Row 1 "Array_Col 8_Row1" (1908.1)	Row 1 "Array_Col 9_Row1" (1909.1)
Set 2
Set 3
...
Set 31	Row 32 "Array_Col 1_Row32" (1901.32)	Row 32 "Array_Col 2_Row32" (1902.32)	Row 32 "Array_Col 3_Row32" (1903.32)	Row 32 "Array_Col 4_Row32" (1904.32)	Row 32 "Array_Col 5_Row32" (1905.32)	Row 32 "Array_Col 6_Row32" (1906.32)	Row 32 "Array_Col 7_Row32" (1907.32)	Row 32 "Array_Col 8_Row32" (1908.32)	Row 32 "Array_Col 9_Row32" (1909.32)

You will find the respective object number in brackets.

Assignment of the different motion functions

Motion function	Column 1	Column 2	Column 4	Column 5	Column 6	Column 7	Column 8
	Type: REAL Objects O1901	Type: REAL Objects O1902	Type: INT Objects O1904	Type: INT Objects O1905	Type: DINT Objects O1906	Type: DINT Objects O1907	Type: DINT Objects O1908
	Positions	Speeds	Programmable status bits (PSBs)	Mode	Accelerations	Deceleration / Denominator	Jerk
MoveAbs (see on page 104)	Target position	Speed	PSBs	1 (for MoveAbs)	Accel	Decel	Jerk
MoveRel (see on page 104)	Distance	Speed	PSBs	2 (for MoveRel)	Accel	Decel	Jerk
Gearing (see on page 109)	-	Numerator	PSBs	3 (for Gearing)	Accel	Denominator	-
RegSearch (see on page 105)	Target position	Speed	PSBs	4 (for RegSearch)	Accel	Decel	Jerk
RegMove (see on page 105)	Offset	Speed	PSBs	5 (for RegMove)	-	-	-
Velocity (see on page 110)	-	Speed	PSBs	6 (for Velocity)	Accel	-	-
STOP	-	-	PSBs	7 (for Stop)	-	Decel	Jerk

The columns 3 and 9 are reserved.

Definition of the states of the programmable status bits (PSBs):

Bit 7	Bit 6	Bit 5	Bit 4	Bit 3	Bit 2	Bit 1	Bit 0
reserved	Enable2 PSB2	Enable1 PSB1	Enable0 PSB0	reserved	PSB2	PSB1	PSB0
	="1": Set PSB ="0": leave PSB unchanged						

The Bits 0 ... 2 monitor the states of the status bits at the end of a motion set, if the bits were enabled via the respective Enable.

If Enable is set to "0", the respective PSB remains unchanged at the end of the motion set.

PSB0: X22/12 or SW.13

PSB1: X22/13 or SW.14

PSB2: X22/14 or SW.15

5.5 RS232 & RS485 – interface record

In this chapter you can read about:

RS485 setting values.....	139
ASCII - record	140
Binary record.....	141

You can communicate with Compax3 in order to read or write objects via plug X10 on the front plate either with RS232 or with RS485.

As a rule 2 records are possible:

- ◆ ASCII record simple communication with Compax3
- ◆ Binary record: fast and secure communication with Compax3 by the aid of block securing.

Switching between the ASCII and the binary record via automatic record detection.

Interface settings (see on page 229)

Wiring RS232: **SSK1** (see on page 211)
 RS485: like **SSK27** (see on page 212) / RS485 is activated via +5V on X10/1.

5.5.1. RS485 setting values

If "Master=Pop" was selected, only the settings compatible with the Pops (Parker Operator Panels) made by Parker are possible.

Please note that the connected Pop has the same RS485 setting values.
You can test this with the "PopDesigner" software.

"Master=General" makes all Compax3 settings possible.

- Multicast Address** You can use this address to allow the master to access multiple devices simultaneously.
- Device Address** The device address of the connected Compax3 can be set here.
- Baud rate** Adjust the transfer speed (baud rate) to the master.
- Connection Type** Please choose between **two wire and four wire – RS485** (see on page 31).
- Protocol** Adjust the protocol settings to the settings of your master.

5.5.2. ASCII - record

The general layout of a command string for Compax3 is as follows:

[Adr] command CR

Adr	RS232: no address RS485: Compax3 address in the range 0 ... 99 Address settings can be made in the C3 ServoManager under "RS485 settings"
Command	valid Compax3 command
CR	End sign (carriage return)

Command A command consists of the representable ASCII characters (0x21 .. 0x7E). Small letters are converted automatically into capitals and blanks (0x20) are deleted, if they are not placed between two quotation marks.

Separator between places before and after the decimal is the decimal point (0x2E).

A numeric value can be given in the Hex-format if it is preceded by the "\$" sign. Values can be requested in the Hex-format if the CR is preceded additionally by the "\$" sign.

Answer strings All commands requesting a numeric value from Compax3 are acknowledged with the respective numeric value in the ASCII format followed by a CR without preceding command repetition and following statement of unit. The length of these answer strings differs depending on the value.

Commands requesting an Info-string (e.g. software version), are only acknowledged with the respective ASCII character sequence followed by a CR, without preceding command repetition. The length of these answer strings is here constant.

Commands transferring a value to Compax3 or triggering a function in Compax3 are acknowledged by:

>CR

if the value can be accepted resp. if the function can be executed at that point in time.

If this is not the case or if the command syntax was invalid, the command is acknowledged with

!xxxxCR

The 4 digit error number **xxxx** is given in the HEX format; you will find the meaning in the appendix (see on page 170).

RS485 answer string When using RS485, each answer string is preceded by a "*" (ASCII - character: 0x2A).

Compax3 commands

Read object *RS232: O [\$] Index , [\$] Subindex [\$]*

RS485: Address O [\$] Index , [\$] Subindex [\$]

The optional "\$" after the subindex stands for "hex-output" which means that an object value can also be requested in hex;
e.g. "O \$0192,2\$":

Write object *RS232: O [\$] Index , [\$] Subindex = [\$] Value [; Value2 ; Value3 ; ...]*

RS485: Address O [\$] Index , [\$] Subindex = [\$] Value [; Value2 ; Value3 ; ...]

The optional "\$" preceding Index, Subindex and value stands for "Hex-input" which means that Index, Subindex and the value to be transferred can also be entered in hex (e.g. O \$0192,2=\$C8).

5.5.3. Binary record

The binary record with block securing is based on 5 different telegrams:

- ◆ 2 request telegrams which the control sends to Compax3 and
- ◆ 3 response telegrams which Compax3 returns to the control.

Telegram layout

Basic structure:

Start code	address	Number of data bytes - 1	Data				block securing	
SZ	A	L	D0	D1	...	Dn	Crc(Hi)	Crc(Lo)

The start code defines the frame type and is composed as follows:

Bit	7	6	5	4	3	2	1	0
Frame type	Frame identification				PLC		Gateway	address
RdObj Read object	1	0	1	0	x	1	x	x
WrObj Write object	1	1	0	0	x	1	x	x
Rsp Answer	0	0	0	0	0	1	0	1
Ack Positive command acknowledgement	0	0	0	0	0	1	1	0
Nak Negative command acknowledgement	0	0	0	0	0	1	1	1

Bits 7, 6, 5 and 4 of the start code form the telegram identification; Bit 2 is always "1".

Bits 3, 1 and 0 have different meanings for the request and response telegrams.

The address is only necessary for RS484.

Request telegrams -> Compax3

- ◆ the address bit (Bit 0 = 1) shows if the start code is followed by an address (only for RS485; for RS232 Bit 0 = 0)
- ◆ the gateway bit (Bit 1 = 1) shows if the message is to be passed on. (Please set Bit 1 = 0, as this function is not yet available)
- ◆ the PLC bit (Bit 3 = 0) allows access to objects in the PLC format (U16, U32, IEEE Floating Point). For information into which PLC format the objects are converted, please refer to the object description.

Response telegram
Compax3 ->

- ◆ Bits 0 and 1 are used to identify the response
- ◆ Bit 3 is always 0

The maximum number of data bytes in the request telegram is 256, in the response telegram 253.

The block securing (CRC16) is made via the CCITT table algorithm for all characters.

After receiving the start code, the timeout monitoring is activated in order to avoid that Compax3 waits in vain for further codes (e.g. connection interrupted) The timeout period between 2 codes received is fixed to 5ms (5 times the code time at 9600Baud)

Write object – WrObj telegram

SZ	Adr	L	D0	D1	D2	D3 ... Dn	Crc(Hi)	Crc(Lo)
0xCX		n	Index(Hi)	Index(Lo)	Subindex	Value	0x..	0x..

Describing an object by a value.

Positive acknowledgement – Ack-telegram

SZ	L	D0	D1	Crc(Hi)	Crc(Lo)
0x06	1	0	0	0x..	0x..

Answer from Compax3 if a writing process was successful, i.e. the function could be executed and is completed in itself.

Negative acknowledgement – Nak - telegram

SZ	L	D0	D1	Crc(Hi)	Crc(Lo)
0x07	1	F-No.(Hi)	F-No.(Lo)	0x..	0x..

Answer from Compax3 if access to the object was denied (e.g. function cannot be executed at that point in time or object has no reading access). The error no. is coded according to the DriveCom profile resp. the CiA Device Profile DSP 402.

Read object – RdObj - telegram

SZ	Adr	L	D0	D1	D2	D3	D4	D5	...	Dn	Crc(Hi)	Crc(Lo)
0xAx		n	Index1(Hi)	Index1(Lo)	Subindex1	Index2(Hi)	Index2(Lo)	Subindex2	0x..	0x..

Reading one or several objects

Answer – Rsp - telegram

SZ	L	D0 ... Dx-1	Dx ... Dy-1	Dy-D..	D ... D..	D ... Dn	Crc(Hi)	Crc(Lo)
0x05	n	Value1	Value 2	Value 3	Value ..	Value n	0x..	0x..

Answer from Compax3 if the object can be read.

If the object has no reading access, Compax3 answers with the Nak – telegram.

Example: Reading object "StatusPositionActual" (o680.5):

Request: A5 03 02 02 A8 05 E1 46

Response: 05 05 FF FF FF FE 2D 07 B4

Writing into an Array (o1901.1 = 2350)

Request: C5 02 08 07 6D 01 00 09 2E 00 00 00 95 D5

Response: 06 01 00 00 BA 87

Block securing:
Checksum calculation for the CCITT table algorithm

The block securing for all codes is performed via the following function and the corresponding table:

The "CRC16" variable is set to "0" before sending a telegram.

Function call:

```
CRC16 = UpdateCRC16(CRC16, Character);
```

This function is called up for each Byte (Character) of the telegram.

The result forms the last two bytes of the telegram

Compax3 checks the CRC value on receipt and reports CRC error in the case of a deviation.

```

Function const unsigned int _P CRC16_table[256] = {
    0x0000, 0x1021, 0x2042, 0x3063, 0x4084, 0x50a5, 0x60c6, 0x70e7,
    0x8108, 0x9129, 0xa14a, 0xb16b, 0xc18c, 0xd1ad, 0xe1ce, 0xf1ef,
    0x1231, 0x0210, 0x3273, 0x2252, 0x52b5, 0x4294, 0x72f7, 0x62d6,
    0x9339, 0x8318, 0xb37b, 0xa35a, 0xd3bd, 0xc39c, 0xf3ff, 0xe3de,
    0x2462, 0x3443, 0x0420, 0x1401, 0x64e6, 0x74c7, 0x44a4, 0x5485,
    0xa56a, 0xb54b, 0x8528, 0x9509, 0xe5ee, 0xf5cf, 0xc5ac, 0xd58d,
    0x3653, 0x2672, 0x1611, 0x0630, 0x76d7, 0x66f6, 0x5695, 0x46b4,
    0xb75b, 0xa77a, 0x9719, 0x8738, 0xf7df, 0xe7fe, 0xd79d, 0xc7bc,
    0x48c4, 0x58e5, 0x6886, 0x78a7, 0x0840, 0x1861, 0x2802, 0x3823,
    0xc9cc, 0xd9ed, 0xe98e, 0xf9af, 0x8948, 0x9969, 0xa90a, 0xb92b,
    0x5af5, 0x4ad4, 0x7ab7, 0x6a96, 0x1a71, 0x0a50, 0x3a33, 0x2a12,
    0xdbfd, 0xcdbc, 0xfbbf, 0xeb9e, 0x9b79, 0x8b58, 0xbb3b, 0xab1a,
    0x6ca6, 0x7c87, 0x4ce4, 0x5cc5, 0x2c22, 0x3c03, 0x0c60, 0x1c41,
    0xedaе, 0xfd8f, 0xcdec, 0xddcd, 0xad2a, 0xbd0b, 0x8d68, 0x9d49,
    0x7e97, 0x6eb6, 0x5ed5, 0x4ef4, 0x3e13, 0x2e32, 0x1e51, 0x0e70,
    0xff9f, 0xefbe, 0xdfdd, 0xcffc, 0xbf1b, 0xaf3a, 0x9f59, 0x8f78,
    0x9188, 0x81a9, 0xb1ca, 0xa1eb, 0xd10c, 0xc12d, 0xf14e, 0xe16f,
    0x1080, 0x00a1, 0x30c2, 0x20e3, 0x5004, 0x4025, 0x7046, 0x6067,
    0x83b9, 0x9398, 0xa3fb, 0xb3da, 0xc33d, 0xd31c, 0xe37f, 0xf35e,
    0x02b1, 0x1290, 0x22f3, 0x32d2, 0x4235, 0x5214, 0x6277, 0x7256,
    0xb5ea, 0xa5cb, 0x95a8, 0x8589, 0xf56e, 0xe54f, 0xd52c, 0xc50d,
    0x34e2, 0x24c3, 0x14a0, 0x0481, 0x7466, 0x6447, 0x5424, 0x4405,
    0xa7db, 0xb7fa, 0x8799, 0x97b8, 0xe75f, 0xf77e, 0xc71d, 0xd73c,
    0x26d3, 0x36f2, 0x0691, 0x16b0, 0x6657, 0x7676, 0x4615, 0x5634,
    0xd94c, 0xc96d, 0xf90e, 0xe92f, 0x99c8, 0x89e9, 0xb98a, 0xa9ab,
    0x5844, 0x4865, 0x7806, 0x6827, 0x18c0, 0x08e1, 0x3882, 0x28a3,
    0xcb7d, 0xdb5c, 0xeb3f, 0xfb1e, 0x8bf9, 0x9bd8, 0xabbb, 0xbb9a,
    0x4a75, 0x5a54, 0x6a37, 0x7a16, 0x0af1, 0x1ad0, 0x2ab3, 0x3a92,
    0xfd2e, 0xed0f, 0xdd6c, 0xcd4d, 0xbdaa, 0xad8b, 0x9de8, 0x8dc9,
    0x7c26, 0x6c07, 0x5c64, 0x4c45, 0x3ca2, 0x2c83, 0x1ce0, 0x0cc1,
    0xef1f, 0xff3e, 0xcf5d, 0xdf7c, 0xaf9b, 0xbfba, 0x8fd9, 0x9ff8,
    0x6e17, 0x7e36, 0x4e55, 0x5e74, 0x2e93, 0x3eb2, 0x0ed1, 0x1ef0
};

unsigned int UpdateCRC16(unsigned int crc,unsigned char value) {

unsigned int crc16;
```

```
    crc16 = (CRC16_table[(crc >> 8) & 0x00FF] ^ (crc << 8)
             ^ (unsigned int)(value));

    return crc16;
```

```
}
```

You will find this function on the Compax3 CD under RS232_485\Function UpdateCRC16.txt!

5.6 Compax3 - Objects

In this chapter you can read about:

Object overview I12 T11	145
I12 T11 object list sorted by object name	146

5.6.1. Object overview I12 T11

Object-No.	Object name	Object	Access
121.2	C3.DigitalInputAddition_Value	Input word of I/O option	ro
133.3	C3.DigitalOutputAddition_Value	Output word for I/O option	r/w
550.1	C3Plus.ErrorHistory_LastError	Current error (n)	ro
550.2	C3.ErrorHistory_1	Error (n-1) in the error history	ro
680.4	C3.StatusPosition_DemandValue	Status demand position	ro
683.2	C3.StatusDevice_ActualDeviceLoad	Status of device utilization	ro
680.5	C3.StatusPosition_Actual	Status actual position	ro
681.4	C3.StatusSpeed_DemandValue	Status demand speed of setpoint generator	ro
684.1	C3.StatusTemperature_PowerStage	Status of power output stage temperature	ro
682.4	C3.StatusAccel_DemandValue	Status demand acceleration	ro
683.3	C3.StatusDevice_ActualMotorLoad	Status of long-term motor load	ro
680.6	C3.StatusPosition_FollowingError	Status of following error	ro
681.5	C3.StatusSpeed_Actual	Status actual speed unfiltered	ro
684.2	C3.StatusTemperature_Motor	Status of motor temperature	ro
685.1	C3.StatusVoltage_AuxiliaryVoltage	Status of auxiliary voltage	ro
682.5	C3.StatusAccel_Actual	Status of actual acceleration unfiltered	ro
681.6	C3.StatusSpeed_Error	Status control deviation of speed	ro
685.2	C3.StatusVoltage_BusVoltage	Status DC bus voltage	ro
682.6	C3.StatusAccel_ActualFilter	Status of filtered actual acceleration	ro
683.5	C3.StatusDevice_ObservedDisturbance	Status of observed disturbance	ro
685.3	C3.StatusVoltage_AnalogInput0	Status of analog input 0	ro
682.7	C3.StatusAccel_FeedForwardAccel	Status acceleration feed forward	ro
688.1	C3.StatusCurrent_Reference	Status of setpoint current RMS (torque forming)	ro
685.4	C3.StatusVoltage_AnalogInput1	Status of analog input 1	ro
688.2	C3.StatusCurrent_Actual	Status of actual current RMS (torque producing)	ro
681.9	C3.StatusSpeed_ActualFilter	Status actual speed filtered	ro
681.10	C3.StatusSpeed_DemandSpeedController	Status demand speed controller input	ro
680.12	C3.StatusPosition_DemandValueController	Status demand position without absolute reference	ro
681.11	C3.StatusSpeed_FeedForwardSpeed	Status speed feed forward	ro
692.1	C3.StatusFeedback_FeedbackSineDSP	Status of sine in signal processing	ro
680.13	C3.StatusPosition_ActualValueController	Status actual position without absolute reference	ro
692.2	C3.StatusFeedback_FeedbackCosineDSP	Status of cosine in signal processing	ro
692.3	C3.StatusFeedback_EncoderSine	Status of analog input sine	ro
688.8	C3.StatusCurrent_ControlDeviationIq	Status of control deviation of current control RMS	ro
692.4	C3.StatusFeedback_EncoderCosine	Status of analog input cosine	ro
688.9	C3.StatusCurrent_PhaseU	Status of current phase U	ro
692.5	C3.StatusFeedback_FeedbackVoltage[Vpp]	Status of feedback level	ro
688.10	C3.StatusCurrent_PhaseV	Status of current phase V	ro

688.11	C3.StatusCurrent_ReferenceVoltageUq	Status of current control control signal	ro
688.13	C3.StatusCurrent_ReferenceJerk	Status of demand jerk setpoint generator	ro
688.14	C3.StatusCurrent_FeedForwardCurrentJerk	Status of current rms and jerk feedforward	ro
990.1	C3.Delay_MasterDelay	Setpoint delay for bus master	r/w
1000.3	C3Plus.DeviceState_Statusword_1	Status word SW	r/w
1000.4	C3Plus.DeviceState_Statusword_2	Status word 2	r/w
1100.3	C3Plus.DeviceControl_Controlword_1	CW control word	r/w
1141.7	C3.GEAR_actual_masterposition	Current master position for Gearing	ro
3300.8	C3Plus.TouchProbe_IgnoreZone_Start	Beginning of the ignore zone	r/w
3300.9	C3Plus.TouchProbe_IgnoreZone_End	End of the ignore zone	r/w

5.6.2. I12 T11 object list sorted by object name

In this chapter you can read about:

I12 T11 Object: Setpoint delay for bus master	147
I12 T11 Object: Input word of I/O option	147
I12 T11 Object: Output word for I/O option	147
I12 T11 Object: Error (n-1) in the error history	147
I12 T11 Object: Current master position for Gearing	148
I12 T11 Object: Status of actual acceleration unfiltered	148
I12 T11 Object: Status of filtered actual acceleration	148
I12 T11 Object: Status demand acceleration	148
I12 T11 Object: Status acceleration feed forward	149
I12 T11 Object: Status of actual current RMS (torque producing)	149
I12 T11 Object: Status of control deviation of current control RMS	149
I12 T11 Object: Status of current rms and jerk feedforward	149
I12 T11 Object: Status of current phase U	149
I12 T11 Object: Status of current phase V	150
I12 T11 Object: Status of setpoint current RMS (torque forming)	150
I12 T11 Object: Status of demand jerk setpoint generator	150
I12 T11 Object: Status of current control control signal	150
I12 T11 Object: Status of device utilization	151
I12 T11 Object: Status of long-term motor load	151
I12 T11 Object: Status of observed disturbance	151
I12 T11 Object: Status of analog input cosine	151
I12 T11 Object: Status of analog input sine	152
I12 T11 Object: Status of cosine in signal processing	152
I12 T11 Object: Status of sine in signal processing	152
I12 T11 Object: Status of feedback level	152
I12 T11 Object: Status actual position	153
I12 T11 Object: Status actual position without absolute reference	153
I12 T11 Object: Status demand position	153
I12 T11 Object: Status demand position without absolute reference	153
I12 T11 Object: Status of following error	153
I12 T11 Object: Status actual speed unfiltered	154
I12 T11 Object: Status actual speed filtered	154
I12 T11 Object: Status demand speed controller input	154
I12 T11 Object: Status demand speed of setpoint generator	154
I12 T11 Object: Status control deviation of speed	154
I12 T11 Object: Status speed feed forward	155
I12 T11 Object: Status of motor temperature	155
I12 T11 Object: Status of power output stage temperature	155
I12 T11 Object: Status of analog input 0	155
I12 T11 Object: Status of analog input 1	156
I12 T11 Object: Status of auxiliary voltage	156
I12 T11 Object: Status DC bus voltage	156
I12 T11 Object: CW control word	156
I12 T11 Object: Status word SW	157
I12 T11 Object: Status word 2	157
I12 T11 Object: Current error (n)	157
I12 T11 Object: End of the ignore zone	157
I12 T11 Object: Beginning of the ignore zone	158

5.6.2.1 I12 T11 Object: Setpoint delay for bus master

Object No.	990.1		
Object name	<i>C3.Delay_MasterDelay</i>		
Unit of Travel	500us	Access:	Read/write
Format:		Valid after:	Immediately
Minimum value	0 500us	Maximum value	19 500us
Remark:	<p>Setpoint delay for bus master.</p> <p>If several axes are to run synchronous to the setpoint value, there is a position offset when accelerating and braking caused by the bus delay time. This object can be used to delay the setpoint value on the master between the setpoint generator and the controller, so that the same delay time as on the slaves is effective on the master. For following axes, the object should always be on 0. For a HEDA master it should be on 2 (=1ms).</p>		

5.6.2.2 I12 T11 Object: Input word of I/O option

Object No.	121.2		
Object name	<i>C3.DigitalInputAddition_Value</i>		
Unit of Travel	n/a	Access:	Read only
Format:	WORD	Valid after:	-
Minimum value	0 n/a	Maximum value	-- n/a
Remark:	Input word for I/O option M10 or M12		

5.6.2.3 I12 T11 Object: Output word for I/O option

Object No.	133.3		
Object name	<i>C3.DigitalOutputAddition_Value</i>		
Unit of Travel	n/a	Access:	Read/write
Format:	WORD	Valid after:	Immediately
Minimum value	0 n/a	Maximum value	-- n/a
Remark:	Output word for I/O option M10 or M12		

5.6.2.4 I12 T11 Object: Error (n-1) in the error history

Object No.	550.2		
Object name	<i>C3.ErrorHistory_1</i>		
Unit of Travel	n/a	Access:	Read only
Format:		Valid after:	-
Minimum value	0 n/a	Maximum value	-- n/a
Remark:	<p>Additional assignment:</p> <p>Object 550.2: Error (n-1) next-to-last error in the error history</p> <p>.....</p> <p>Object 550.32: Error (n-31) in the error history.</p>		

5.6.2.5 I12 T11 Object: Current master position for Gearing

Object No.	1141.7		
Object name	<i>C3.GEAR_actual_masterposition</i>		
Unit of Travel	rounds	Access:	Read only
Format:		Valid after:	-
Minimum value	0 n/a	Maximum value	-- n/a
Remark:	Does not apply for I11T11 Status value of the incoming master signal before it is set against the path/motor revolutions factor of the master		

5.6.2.6 I12 T11 Object: Status of actual acceleration unfiltered

Object No.	682.5		
Object name	<i>C3.StatusAccel_Actual</i>		
Unit of Travel	Unit/s ²	Access:	Read only
Format:	DINT	Valid after:	-
Minimum value	-1000000 unit/s ²	Maximum value	1000000 unit/s ²
Remark:	Please note that this signal is often rather noisy.		

5.6.2.7 I12 T11 Object: Status of filtered actual acceleration

Object No.	682.6		
Object name	<i>C3.StatusAccel_ActualFilter</i>		
Unit of Travel	Unit/s ²	Access:	Read only
Format:	DINT	Valid after:	-
Minimum value	-1000000 unit/s ²	Maximum value	1000000 unit/s ²
Remark:	Signal is smoothed by acceleration filter 1 and 2 resp. by the rotational speed monitor and acceleration filter 2. Signal is the source of the D-component in the (rotational) speed controller		

5.6.2.8 I12 T11 Object: Status demand acceleration

Object No.	682.4		
Object name	<i>C3.StatusAccel_DemandValue</i>		
Unit of Travel	Unit/s ²	Access:	Read only
Format:	DINT	Valid after:	-
Minimum value	-1000000 unit/s ²	Maximum value	1000000 unit/s ²
Remark:	Setpoint acceleration setpoint generator Stated in user units Output value of the fine interpolator		

5.6.2.9 I12 T11 Object: Status acceleration feed forward

Object No.	682.7		
Object name	<i>C3.StatusAccel_FeedForwardAccel</i>		
Unit of Travel	Unit/s	Access:	Read only
Format:	REAL	Valid after:	-
Minimum value	0 unit/s	Maximum value	-- unit/s
Remark:	Given in user units (rotational speed format)		

5.6.2.10 I12 T11 Object: Status of actual current RMS (torque producing)

Object No.	688.2		
Object name	<i>C3.StatusCurrent_Actual</i>		
Unit of Travel	mA	Access:	Read only
Format:	REAL	Valid after:	-
Minimum value	-353553 mA	Maximum value	353553 mA
Remark:	Actual current RM (torque producing) ,actual value after filter		

5.6.2.11 I12 T11 Object: Status of control deviation of current control RMS

Object No.	688.8		
Object name	<i>C3.StatusCurrent_ControlDeviationIq</i>		
Unit of Travel	mA	Access:	Read only
Format:	REAL	Valid after:	-
Minimum value	-353553 mA	Maximum value	353553 mA
Remark:	Control deviation of current RMS (torque producing)		

5.6.2.12 I12 T11 Object: Status of current rms and jerk feedforward

Object No.	688.14		
Object name	<i>C3.StatusCurrent_FeedForwordCurrentJerk</i>		
Unit of Travel	mA	Access:	Read only
Format:	REAL	Valid after:	-
Minimum value	-353553 mA	Maximum value	353553 mA
Remark:	Current & jerk feedforward RMS Stated in amperes RMS after filter		

5.6.2.13 I12 T11 Object: Status of current phase U

Object No.	688.9		
Object name	<i>C3.StatusCurrent_PhaseU</i>		
Unit of Travel	mA	Access:	Read only
Format:	REAL	Valid after:	-
Minimum value	-500000 mA	Maximum value	500000 mA
Remark:	Phase current U, Output as peak value Actual value after oversampling		

5.6.2.14 I12 T11 Object: Status of current phase V

Object No.	688.10		
Object name	<i>C3.StatusCurrent_PhaseV</i>		
Unit of Travel	mA	Access:	Read only
Format:	REAL	Valid after:	-
Minimum value	-500000 mA	Maximum value	500000 mA
Remark:	Phase current V, Output as peak value Actual value after oversampling		

5.6.2.15 I12 T11 Object: Status of setpoint current RMS (torque forming)

Object No.	688.1		
Object name	<i>C3.StatusCurrent_Reference</i>		
Unit of Travel	mA	Access:	Read only
Format:	REAL	Valid after:	-
Minimum value	-353553 mA	Maximum value	353553 mA
Remark:	Setpoint motor current RMS. (torque-producing) Cross-flow setpoint value including current and jerk feedforward		

5.6.2.16 I12 T11 Object: Status of demand jerk setpoint generator

Object No.	688.13		
Object name	<i>C3.StatusCurrent_ReferenceJerk</i>		
Unit of Travel	Unit/s ³	Access:	Read only
Format:	REAL	Valid after:	-
Minimum value	0 unit/s ³	Maximum value	-- unit/s ³
Remark:	Jerk setpoint generator value Stated in user units Output value of the fine interpolator		

5.6.2.17 I12 T11 Object: Status of current control control signal

Object No.	688.11		
Object name	<i>C3.StatusCurrent_ReferenceVoltageUq</i>		
Unit of Travel	n/a	Access:	Read only
Format:	REAL	Valid after:	-
Minimum value	0 n/a	Maximum value	0.577 n/a
Remark:	Control signal of current controller (torque forming) 0.577 correspond to full range (Terminal voltage=DC bus voltage)		

5.6.2.18 I12 T11 Object: Status of device load

Object No.	683.2		
Object name	<i>C3.StatusDevice_ActualDeviceLoad</i>		
Unit of Travel	%	Access:	Read only
Format:	REAL	Valid after:	-
Minimum value	0 %	Maximum value	-- %
Remark:	Device utilization Stated in % of the nominal device current		

5.6.2.19 I12 T11 Object: Status of long-term motor load

Object No.	683.3		
Object name	<i>C3.StatusDevice_ActualMotorLoad</i>		
Unit of Travel	%	Access:	Read only
Format:	REAL	Valid after:	-
Minimum value	0 %	Maximum value	105 %
Remark:	Motor load, Stated in & of the motor pulse current. Effective motor load with reference to the nominal motor current resp. if a motor reference point is selected, with reference to the motor reference current. For the monitoring the thermal time constant Tau is required. 1.05*I can be set permanently. Error object 500.1 Bit 13, Error Code 2311		

5.6.2.20 I12 T11 Object: Status of observed disturbance

Object No.	683.5		
Object name	<i>C3.StatusDevice_ObservedDisturbance</i>		
Unit of Travel	%	Access:	Read only
Format:	REAL	Valid after:	-
Minimum value	-2000 %	Maximum value	2000 %
Remark:	Load moment resp. load force detected by the (rotational) speed monitor. Unit is % of Mnominal resp. of Fnominal (100% = Moment resp. force given the configured nominal resp. reference current)		

5.6.2.21 I12 T11 Object: Status of analog input cosine

Object No.	692.4		
Object name	<i>C3.StatusFeedback_EncoderCosine</i>		
Unit of Travel	n/a	Access:	Read only
Format:		Valid after:	-
Minimum value	0 n/a	Maximum value	1 n/a
Remark:	Cosine trace of encoder, for F11 and F12 devices		

5.6.2.22 I12 T11 Object: Status of analog input sine

Object No.	692.3		
Object name	<i>C3.StatusFeedback_EncoderSine</i>		
Unit of Travel	n/a	Access:	Read only
Format:		Valid after:	-
Minimum value	0 n/a	Maximum value	1 n/a
Remark:	Sine track of encoder, for F11 and F12 devices (0.5 = 2.5V)		

5.6.2.23 I12 T11 Object: Status of cosine in signal processing

Object No.	692.2		
Object name	<i>C3.StatusFeedback_FeedbackCosineDSP</i>		
Unit of Travel	n/a	Access:	Read only
Format:		Valid after:	-
Minimum value	0 n/a	Maximum value	1 n/a
Remark:	Cosine trace of resolver, for F10 devices The value 1 corresponds to 2.5 Volts The amplitude must be <1 and > 0.1 at the resolver; otherwise a level error is reported.		

5.6.2.24 I12 T11 Object: Status of sine in signal processing

Object No.	692.1		
Object name	<i>C3.StatusFeedback_FeedbackSineDSP</i>		
Unit of Travel	n/a	Access:	Read only
Format:		Valid after:	-
Minimum value	0 n/a	Maximum value	1 n/a
Remark:	Sinus track resolver, for F10 devices The value 1 corresponds to 2.5 Volts The amplitude must be <1 and > 0.1 at the resolver; otherwise a level error is reported.		

5.6.2.25 I12 T11 Object: Status of feedback level

Object No.	692.5		
Object name	<i>C3.StatusFeedback_FeedbackVoltage[Vpp]</i>		
Unit of Travel	V	Access:	Read only
Format:		Valid after:	-
Minimum value	0 V	Maximum value	-- V
Remark:	Feedback level, for F11 and F12 devices, display in Vpp (=sqrt(sin ² +cos ²))		

5.6.2.26 I12 T11 Object: Status actual position

Object No.	680.5		
Object name	<i>C3.StatusPosition_Actual</i>		
Unit of Travel	Unit	Access:	Read only
Format:	REAL	Valid after:	-
Minimum value	0 n/a	Maximum value	-- n/a
Remark:	Stated in user units, reset position		

5.6.2.27 I12 T11 Object: Status actual position without absolute reference

Object No.	680.13		
Object name	<i>C3.StatusPosition_ActualValueController</i>		
Unit of Travel	Unit	Access:	Read only
Format:	REAL	Valid after:	-
Minimum value	0 unit	Maximum value	-- unit
Remark:	Stated in user units, continuous position		

5.6.2.28 I12 T11 Object: Status demand position

Object No.	680.4		
Object name	<i>C3.StatusPosition_DemandValue</i>		
Unit of Travel	Unit	Access:	Read only
Format:	REAL	Valid after:	-
Minimum value	0 n/a	Maximum value	-- n/a
Remark:	Stated in user units, reset position		

5.6.2.29 I12 T11 Object: Status demand position without absolute reference

Object No.	680.12		
Object name	<i>C3.StatusPosition_DemandValueController</i>		
Unit of Travel	Unit	Access:	Read only
Format:	REAL	Valid after:	-
Minimum value	0 unit	Maximum value	-- unit
Remark:	Stated in user units, continuous position		

5.6.2.30 I12 T11 Object: Status of following error

Object No.	680.6		
Object name	<i>C3.StatusPosition_FollowingError</i>		
Unit of Travel	Unit	Access:	Read only
Format:	REAL	Valid after:	-
Minimum value	0 n/a	Maximum value	-- n/a
Remark:	Stated in user units, difference between target and actual value of position		

5.6.2.31 I12 T11 Object: Status actual speed unfiltered

Object No.	681.5		
Object name	<i>C3.StatusSpeed_Actual</i>		
Unit of Travel	Unit/s	Access:	Read only
Format:	REAL	Valid after:	-
Minimum value	-8388608 unit/s	Maximum value	8388607.999999 unit/s
Remark:			

5.6.2.32 I12 T11 Object: Status actual speed filtered

Object No.	681.9		
Object name	<i>C3.StatusSpeed_ActualFilter</i>		
Unit of Travel	Unit/s	Access:	Read only
Format:	REAL	Valid after:	-
Minimum value	-8388608 unit/s	Maximum value	8388607.999999 unit/s
Remark:			

5.6.2.33 I12 T11 Object: Status demand speed controller input

Object No.	681.10		
Object name	<i>C3.StatusSpeed_DemandSpeedController</i>		
Unit of Travel	Unit/s	Access:	Read only
Format:	REAL	Valid after:	-
Minimum value	0 unit/s	Maximum value	-- unit/s
Remark:	Speed setpoint value on the controller input including feed forward		

5.6.2.34 I12 T11 Object: Status demand speed of setpoint generator

Object No.	681.4		
Object name	<i>C3.StatusSpeed_DemandValue</i>		
Unit of Travel	Unit/s	Access:	Read only
Format:	REAL	Valid after:	-
Minimum value	0 n/a	Maximum value	-- n/a
Remark:	Setpoint value according to the fine interpolator		

5.6.2.35 I12 T11 Object: Status control deviation of speed

Object No.	681.6		
Object name	<i>C3.StatusSpeed_Error</i>		
Unit of Travel	Unit/s	Access:	Read only
Format:	REAL	Valid after:	-
Minimum value	0 n/a	Maximum value	-- n/a
Remark:	Difference between speed Setpoint value and filtered actual value		

5.6.2.36 I12 T11 Object: Status speed feed forward

Object No.	681.11		
Object name	<i>C3.StatusSpeed_FeedForwardSpeed</i>		
Unit of Travel	Unit/s	Access:	Read only
Format:	REAL	Valid after:	-
Minimum value	0 unit/s	Maximum value	-- unit/s
Remark:			

5.6.2.37 I12 T11 Object: Status of motor temperature

Object No.	684.2		
Object name	<i>C3.StatusTemperature_Motor</i>		
Unit of Travel	C	Access:	Read only
Format:	INT	Valid after:	-
Minimum value	0 C	Maximum value	-- C
Remark:	Motor Temperature measured via the sensor in the motor, correct display only with KTY84		

5.6.2.38 I12 T11 Object: Status of power output stage temperature

Object No.	684.1		
Object name	<i>C3.StatusTemperature_PowerStage</i>		
Unit of Travel	C	Access:	Read only
Format:	INT	Valid after:	-
Minimum value	0 C	Maximum value	-- C
Remark:	Power Stage Temperature		

5.6.2.39 I12 T11 Object: Status of analog input 0

Object No.	685.3		
Object name	<i>C3.StatusVoltage_AnalogInput0</i>		
Unit of Travel	V	Access:	Read only
Format:	REAL	Valid after:	-
Minimum value	-10 V	Maximum value	10 V
Remark:	Analog input 0 Analog input on plug X11/9 and X11/11 Indication of the voltage measured on the input in volts		

5.6.2.40 I12 T11 Object: Status of analog input 1

Object No.	685.4		
Object name	<i>C3.StatusVoltage_AnalogInput1</i>		
Unit of Travel	V	Access:	Read only
Format:	REAL	Valid after:	-
Minimum value	-10 V	Maximum value	10 V
Remark:	Analog input 1 Analog input on plug X11/10 and X11/2 Indication of the voltage measured on the input in volts		

5.6.2.41 I12 T11 Object: Status of auxiliary voltage

Object No.	685.1		
Object name	<i>C3.StatusVoltage_AuxiliaryVoltage</i>		
Unit of Travel	V	Access:	Read only
Format:	REAL	Valid after:	-
Minimum value	0 V	Maximum value	-- V
Remark:	Control Voltage		

5.6.2.42 I12 T11 Object: Status DC bus voltage

Object No.	685.2		
Object name	<i>C3.StatusVoltage_BusVoltage</i>		
Unit of Travel	V	Access:	Read only
Format:	REAL	Valid after:	-
Minimum value	0 V	Maximum value	-- V
Remark:	unfiltered signal		

5.6.2.43 I12 T11 Object: CW control word

Object No.	1100.3		
Object name	<i>C3Plus.DeviceControl_Controlword_1</i>		
Unit of Travel	n/a	Access:	Read/write
Format:	WORD	Valid after:	Immediately
Minimum value	0 n/a	Maximum value	-- n/a
Remark:	I12T11: Control word I20/21 T11: profile dependent I20/21 T30/40: freely programmable		

5.6.2.44 I12 T11 Object: Status word SW

Object No.	1000.3		
Object name	<i>C3Plus.DeviceState_Statusword_1</i>		
Unit of Travel	n/a	Access:	Read/write
Format:	WORD	Valid after:	Immediately
Minimum value	0 n/a	Maximum value	-- n/a
Remark:	I12T11: Status word1 I20/21 T11: profile dependent I20/21 T30/40: freely programmable		

5.6.2.45 I12 T11 Object: Status word 2

Object No.	1000.4		
Object name	<i>C3Plus.DeviceState_Statusword_2</i>		
Unit of Travel	n/a	Access:	Read/write
Format:	WORD	Valid after:	Immediately
Minimum value	0 n/a	Maximum value	-- n/a
Remark:	I12T11: Status word2 I20/21 T11: profile dependent I20/21 T30/40: freely programmable		

5.6.2.46 I12 T11 Object: Current error (n)

Object No.	550.1		
Object name	<i>C3Plus.ErrorHistory_LastError</i>		
Unit of Travel	n/a	Access:	Read only
Format:	INT	Valid after:	-
Minimum value	0 n/a	Maximum value	-- n/a
Remark:	Last entry in the error history Entry of errors that occurred with the corresponding error number for each one Acknowledgement by Ackn or Power on will be written with a 1.		

5.6.2.47 I12 T11 Object: End of the ignore zone

Object No.	3300.9		
Object name	<i>C3Plus.TouchProbe_IgnoreZone_End</i>		
Unit of Travel	Unit	Access:	Read/write
Format:	REAL	Valid after:	Immediately
Minimum value	0 unit	Maximum value	-- unit
Remark:	The beginning of the ignore zone must always be smaller than the end of the ignore zone. Only positive values make sense. The sign is inverted automatically when searching in neg. direction.		

5.6.2.48 I12 T11 Object: Beginning of the ignore zone

Object No.	3300.8		
Object name	<i>C3Plus.TouchProbe_IgnoreZone_Start</i>		
Unit of Travel	Unit	Access:	Read/write
Format:	REAL	Valid after:	Immediately
Minimum value	0 unit	Maximum value	-- unit
Remark:	The beginning of the ignore zone must always be smaller than the end of the ignore zone. Only positive values make sense. The sign is inverted automatically when searching in neg. direction.		

6. Status values

In this chapter you can read about:

Drive	160
Motor	160
Position.....	161
Speeds	162
Superimposed motion.....	163
Current.....	164
Inputs.....	165
Cam	165
Virtual Master	166
IEC61131-3	167
Feedback.....	167
Gearing.....	169

A list of the status values supports you in optimization and commissioning.

Open the optimization function in the C3 ServoManager (double-click on optimization in the tree)

You will find the available status values in the lower right part of the window under selection (TAB) "Status values"

You can pull them into the oscilloscope (upper part of the left side) or into the status display (upper part of the right side) by the aid of the mouse (drag and drop).

The status values are divided into 2 groups (user levels):

standard: here you can find all important status values

advanced: advanced status values, require a better knowledge

Switching of the user level

The user level can be changed in the optimization window (left hand side lower part under selection (TAB) "optimization") with the following button.



D/A-Monitor

A part of the status values can be output via the D/A monitor channel 0 (X11/4) and channel 1 (X11/3).

The reference for the output voltage can be entered individually in the reference unit of the D/A monitor.

Hint

The unit of measurement of the D/A monitor values differs from the unit of measurement of the status values.

6.1 Drive

Status of power output stage temperature			Object 684.1
available	in all Compax3 device types		
Object name	C3.StatusTemperature_PowerStage		
User level	standard	D/A monitor output	not possible
Remark:	Power Stage Temperature		
Status of device load			Object 683.2
available	in all Compax3 device types		
Object name	C3.StatusDevice_ActualDeviceLoad		
User level	standard	D/A monitor output	not possible
Remark:	Device load Stated in % of the nominal device current		
Status of auxiliary voltage			Object 685.1
available	in all Compax3 device types		
Object name	C3.StatusVoltage_AuxiliaryVoltage		
User level	standard	D/A monitor output	not possible
Remark:	Control Voltage		
Status DC bus voltage			Object 685.2
available	in all Compax3 device types		
Object name	C3.StatusVoltage_BusVoltage		
User level	standard	D/A monitor output	possible
Remark:	unfiltered signal		

6.2 Motor

Status of long-term motor load			Object 683.3
available	in all Compax3 device types		
Object name	C3.StatusDevice_ActualMotorLoad		
User level	standard	D/A monitor output	not possible
Remark:	Motor load, Stated in % of the motor pulse current. Effective motor load with reference to the nominal motor current resp. if a motor reference point is selected, with reference to the motor reference current. For the monitoring the thermal time constant Tau is required. 1.05*I can be set permanently. Error object 500.1 Bit 13, Error Code 2311		

Status of short-term motor load			Object 683.4
available	in all Compax3 device types		
Object name	C3.StatusDevice_DynamicMotorLoad		
User level	standard	D/A monitor output	not possible
Remark:	Motor pulse utilization, Stated in & of the motor pulse current. Dynamic motor load with reference to the nominal motor current resp., in the case of a selected motor reference point, with reference to the motor reference current. For the monitoring the impulse current and the impulse current time are required in order to calculate a time constant. 1.15*1 can be set permanently. Error object 500.6 Bit 6, Error Code 7180		
Status of motor temperature			Object 684.2
available	in all Compax3 device types		
Object name	C3.StatusTemperature_Motor		
User level	standard	D/A monitor output	not possible
Remark:	Motor Temperature measured via the sensor in the motor, correct display only with KTY84		

6.3 Position

Status demand position without absolute reference			Object 680.12
available	in all Compax3 device types except I10T10		
Object name	C3.StatusPosition_DemandValueController		
User level	advanced	D/A monitor output	possible
Remark:	Stated in user units, continuous position		
Status demand position			Object 680.4
available	I10T10		
Object name	C3.StatusPosition_DemandValue		
User level	advanced	D/A monitor output	not possible
Remark:	Stated in user units, reset position		
Status demand position			Object 680.4
available	in all Compax3 device types except I10T10		
Object name	C3.StatusPosition_DemandValue		
User level	standard	D/A monitor output	possible
Remark:	Stated in user units, reset position		
Status actual position			Object 680.5
available	in all Compax3 device types except I10T10		
Object name	C3.StatusPosition_Actual		
User level	standard	D/A monitor output	possible
Remark:	Stated in user units, reset position		
Status actual position			Object 680.5
available	I10T10		
Object name	C3.StatusPosition_Actual		
User level	advanced	D/A monitor output	not possible
Remark:	Stated in user units, reset position		

Status of following error			Object 680.6
available	in all Compax3 device types except I10T10		
Object name	C3.StatusPosition_FollowingError		
User level	standard	D/A monitor output	possible
Remark:	Stated in user units, difference between target and actual value of position		
Status of following error			Object 680.6
available	I10T10		
Object name	C3.StatusPosition_FollowingError		
User level	advanced	D/A monitor output	not possible
Remark:	Stated in user units, difference between target and actual value of position		
Status actual position without absolute reference			Object 680.13
available	in all Compax3 device types		
Object name	C3.StatusPosition_ActualValueController		
User level	advanced	D/A monitor output	possible
Remark:	Stated in user units, continuous position		

6.4 Speeds

Status demand speed of setpoint generator			Object 681.4
available	in all Compax3 device types		
Object name	C3.StatusSpeed_DemandValue		
User level	standard	D/A monitor output	possible
Remark:	Setpoint value according to the fine interpolator		
Status demand acceleration			Object 682.4
available	in all Compax3 device types		
Object name	C3.StatusAccel_DemandValue		
User level	advanced	D/A monitor output	not possible
Remark:	Setpoint acceleration setpoint generator Stated in user units Output value of the fine interpolator		
Status actual speed unfiltered			Object 681.5
available	in all Compax3 device types		
Object name	C3.StatusSpeed_Actual		
User level	advanced	D/A monitor output	possible
Remark:			
Status acceleration feed forward			Object 682.7
available	in all Compax3 device types except I10T10		
Object name	C3.StatusAccel_FeedForwardAccel		
User level	advanced	D/A monitor output	not possible
Remark:	Given in user units (rotational speed format)		
Status control deviation of speed			Object 681.6
available	in all Compax3 device types		
Object name	C3.StatusSpeed_Error		
User level	standard	D/A monitor output	possible
Remark:	Difference between speed Setpoint value and filtered actual value		

Status actual speed filtered			Object 681.9
available	in all Compax3 device types		
Object name	C3.StatusSpeed_ActualFilter		
User level	standard	D/A monitor output	possible
Remark:			
Status demand speed controller input			Object 681.10
available	in all Compax3 device types		
Object name	C3.StatusSpeed_DemandSpeedController		
User level	standard	D/A monitor output	possible
Remark:	Speed setpoint value on the controller input including feed forward		
Status of observed disturbance			Object 683.5
available	in all Compax3 device types		
Object name	C3.StatusDevice_ObservedDisturbance		
User level	advanced	D/A monitor output	possible
Remark:	Load moment resp. load force detected by the (rotational) speed monitor. Unit is % of Mnominal resp. of Fnominal (100% = Moment resp. force given the configured nominal resp. reference current)		
Status of filtered actual acceleration			Object 682.6
available	in all Compax3 device types		
Object name	C3.StatusAccel_ActualFilter		
User level	advanced	D/A monitor output	possible
Remark:	Signal is smoothed by acceleration filter 1 and 2 resp. by the rotational speed monitor and acceleration filter 2. Signal is the source of the D-component in the (rotational) speed controller		
Status of actual acceleration unfiltered			Object 682.5
available	in all Compax3 device types		
Object name	C3.StatusAccel_Actual		
User level	advanced	D/A monitor output	possible
Remark:	Please note that this signal is often rather noisy.		
Status speed feed forward			Object 681.11
available	in all Compax3 device types except I10T10		
Object name	C3.StatusSpeed_FeedForwardSpeed		
User level	advanced	D/A monitor output	not possible
Remark:			

6.5 Superimposed motion

Speed of a superimposed motion			Object 681.3
available	IxxT30, IxxT40		
Object name	C3.StatusSpeed_DemandValue3		
User level	standard	D/A monitor output	not possible
Remark:	Speed of a superimposed motion, caused by MC_Phasing, MC_SuperImposed or C3_ShiftPosition.		

6.6 Current

Status of control deviation of current control RMS			Object 688.8
available	in all Compax3 device types		
Object name	C3.StatusCurrent_ControlDeviationIq		
User level	advanced	D/A monitor output	possible
Remark:	Control deviation of current RMS (torque producing)		
Status of actual current RMS (torque producing)			Object 688.2
available	in all Compax3 device types		
Object name	C3.StatusCurrent_Actual		
User level	standard	D/A monitor output	possible
Remark:	Actual current RM (torque producing) ,actual value after filter		
Status of current phase U			Object 688.9
available	in all Compax3 device types		
Object name	C3.StatusCurrent_PhaseU		
User level	advanced	D/A monitor output	not possible
Remark:	Phase current U, Output as peak value Actual value after oversampling		
Status of current phase V			Object 688.10
available	in all Compax3 device types		
Object name	C3.StatusCurrent_PhaseV		
User level	advanced	D/A monitor output	not possible
Remark:	Phase current V, Output as peak value Actual value after oversampling		
Status of current control control signal			Object 688.11
available	in all Compax3 device types		
Object name	C3.StatusCurrent_ReferenceVoltageUq		
User level	advanced	D/A monitor output	not possible
Remark:	Control signal of current controller (torque forming) 0.577 correspond to full range (Terminal voltage=DC bus voltage)		
Status of demand jerk setpoint generator			Object 688.13
available	in all Compax3 device types except I10T10		
Object name	C3.StatusCurrent_ReferenceJerk		
User level	advanced	D/A monitor output	not possible
Remark:	Jerk setpoint generator value Stated in user units Output value of the fine interpolator		
Status of current rms and jerk feedforward			Object 688.14
available	in all Compax3 device types		
Object name	C3.StatusCurrent_FeedForwordCurrentJerk		
User level	advanced	D/A monitor output	not possible
Remark:	Current & jerk feedforward RMS Stated in amperes RMS after filter		

Status of setpoint current RMS (torque forming)			Object 688.1
available	in all Compax3 device types		
Object name	C3.StatusCurrent_Reference		
User level	standard	D/A monitor output	possible
Remark:	Setpoint motor current RMS. (torque-producing) Cross-flow setpoint value including current and jerk feedforward		

6.7 Inputs

Status of analog input 0			Object 685.3
available	in all Compax3 device types		
Object name	C3.StatusVoltage_AnalogInput0		
User level	standard	D/A monitor output	possible
Remark:	Analog input 0 Analog input on plug X11/9 and X11/11 Indication of the voltage measured on the input in volts		

Status of analog input 1			Object 685.4
available	in all Compax3 device types		
Object name	C3.StatusVoltage_AnalogInput1		
User level	standard	D/A monitor output	possible
Remark:	Analog input 1 Analog input on plug X11/10 and X11/2 Indication of the voltage measured on the input in volts		

Status of encoder input 0 (24V)			Object 680.11
available	in all Compax3 device types		
Object name	C3.StatusPosition_EncoderInput24V		
User level	standard	D/A monitor output	not possible
Remark:	Encoder input 1 (24V), counter state in turns of the encoder		

Status of encoder input 0 (5V)			Object 680.10
available	in all Compax3 device types		
Object name	C3.StatusPosition_EncoderInput5V		
User level	standard	D/A monitor output	not possible
Remark:	Encoder input 0 (5V), counter state in turns of the encoder		

6.8 Cam

Master position at the beginning of the curve			Object 3030.24
available	I11T40, I20T40, I21T40		
Object name	C3Cam.StatusMaster_PositionCamUnits		
User level	standard	D/A monitor output	not possible
Remark:	[Master units]		

End of curve			Object 3032.24
available	I11T40, I20T40, I21T40		
Object name	C3Cam.StatusOutput_CurvePositionUnits		
User level	standard	D/A monitor output	not possible
Remark:	[Slave units]		
Master speed [Units/s]			Object 3030.22
available	I11T40, I20T40, I21T40		
Object name	C3Cam.StatusMaster_SpeedUnits		
User level	standard	D/A monitor output	not possible
Remark:			
Reset master position			Object 3030.1
available	I11T40, I20T40, I21T40		
Object name	C3Cam.StatusMaster_Position		
User level	standard	D/A monitor output	possible
Remark:			
Status of position of selected master signal source			Object 3021.2
available	I11T40, I20T40, I21T40		
Object name	C3Cam.SignalSource_Position		
User level	standard	D/A monitor output	possible
Remark:			
Current curve number			Object 3031.4
available	I11T40, I20T40, I21T40		
Object name	C3Cam.StatusData_ActualCurve		
User level	standard	D/A monitor output	not possible
Remark:			
Slave position			Object 3032.1
available	I11T40, I20T40, I21T40		
Object name	C3Cam.StatusOutput_Position		
User level	standard	D/A monitor output	possible
Remark:	reset position after cam table [Units]		

6.9 Virtual Master

Status demand speed virtual master			Object 681.2
available	I11T40, I20T40, I21T40		
Object name	C3.StatusSpeed_DemandValue2		
User level	standard	D/A monitor output	not possible
Remark:	The setpoint speed value of the virtual axis (virtual Master / profile transmitter 2)		
Status demand position virtual master			Object 680.2
available	I11T40, I20T40, I21T40		
Object name	C3.StatusPosition_DemandValue2		
User level	standard	D/A monitor output	not possible
Remark:	The position setpoint value of the virtual axis (virtual Master / profile transmitter 2)		

6.10 IEC61131-3

Status of maximum cycle time			Object 50.4
available	lxxT30, lxxT40		
Object name	C3Plus.PLC_ActualCycleTimeMax		
User level	standard	D/A monitor output	not possible
Remark:	Maximum cycle time [unit: 1=500µs] Very large values may occur here with the command "Save objects permanently". Then the control program will no longer be executed for the execution time (about 1.5 sec)		
Status of cycle time of the control program			Object 50.3
available	lxxT30, lxxT40		
Object name	C3Plus.PLC_ActualCycleTime		
User level	standard	D/A monitor output	not possible
Remark:	Current cycle time [unit: 1=500µs] of the control program		
Setpoint for analog output 0			Object 634.4
available	lxxT30, lxxT40		
Object name	C3.AnalogOutput0_DemandValue		
User level	advanced	D/A monitor output	possible
Remark:	Setpoint for analog output 0 (DA0 - X11/4); can be used as a DA monitor. This output must be previously activated to be able to access it. You can do this in the ServoManager in the optimization window in the partial window at the bottom left under DA monitor. Convert the signal source to IEC61131.		
Setpoint for analog output 1			Object 635.4
available	lxxT30, lxxT40		
Object name	C3.AnalogOutput1_DemandValue		
User level	advanced	D/A monitor output	possible
Remark:	Setpoint for analog output 1 (DA1 - X11/3); can be used as DA monitor. This output must be previously activated to be able to access it. You can do this in the ServoManager in the optimization window in the partial window at the bottom left under DA monitor. Convert the signal source to IEC61131.		

6.11 Feedback

Hall sensor 2			Object 691.5
available	in all Compax3 device types		
Object name	C3.StatusHallcommutation_Bit2		
User level	advanced	D/A monitor output	not possible
Remark:			
Status of feedback level			Object 692.5
available	in all Compax3 device types		
Object name	C3.StatusFeedback_FeedbackVoltage[Vpp]		
User level	advanced	D/A monitor output	not possible
Remark:	Feedback level, for F11 and F12 devices, display in Vpp (=sqrt(sin ² +cos ²))		

Status of analog input cosine			Object 692.4
available	in all Compax3 device types		
Object name	C3.StatusFeedback_EncoderCosine		
User level	advanced	D/A monitor output	not possible
Remark:	Cosine trace of encoder, for F11 and F12 devices		
Status of analog input sine			Object 692.3
available	in all Compax3 device types		
Object name	C3.StatusFeedback_EncoderSine		
User level	advanced	D/A monitor output	not possible
Remark:	Sine track of encoder, for F11 and F12 devices (0.5 = 2.5V)		
Status of cosine in signal processing			Object 692.2
available	in all Compax3 device types		
Object name	C3.StatusFeedback_FeedbackCosineDSP		
User level	advanced	D/A monitor output	not possible
Remark:	Cosine trace of resolver, for F10 devices The value 1 corresponds to 2.5 Volts The amplitude must be <1 and > 0.1 at the resolver; otherwise a level error is reported.		
Hall sensor 3			Object 691.6
available	in all Compax3 device types		
Object name	C3.StatusHallcommutation_Bit3		
User level	advanced	D/A monitor output	not possible
Remark:			
Hall sensor 1			Object 691.4
available	in all Compax3 device types		
Object name	C3.StatusHallcommutation_Bit1		
User level	advanced	D/A monitor output	not possible
Remark:			
Status of sine in signal processing			Object 692.1
available	in all Compax3 device types		
Object name	C3.StatusFeedback_FeedbackSineDSP		
User level	advanced	D/A monitor output	not possible
Remark:	Sinus track resolver, for F10 devices The value 1 corresponds to 2.5 Volts The amplitude must be <1 and > 0.1 at the resolver; otherwise a level error is reported.		

6.12 Gearing

Current master position for Gearing		Object 1141.7	
available	I12T11, I20T11, I21T11, IxxT30, IxxT40		
Object name	C3.GEAR_actual_masterposition		
User level	standard	D/A monitor output	not possible
Remark:	Does not apply for I11T11 Status value of the incoming master signal before it is set against the path/motor revolutions factor of the master		

7. Error

All errors lead to error status.

Reaction 2: Downramp with "de-energize" ramp **then apply brake** (see on page 123) and then de-energize.

Reaction 5: switch-off of the current immediately (without ramp), application of the brake.

Caution! A Z-axis may drop down due to the brake delay times

Most pending errors can be acknowledged with Quit!

The following errors must be acknowledged with Power on:

0x7381, 0x7382, 0x7391, 0x7392, 0x73A0

The errors as well as the error history can be viewed in the C3 ServoManager under optimization (at the top right of the optimization window).

7.1 Error list

2311 _h 8977 _d	Error code (hex):	0x2311
	Error:	Effective motor current monitor
	Error reaction:	Reaction 2: Downramp / apply brake / de-energize.
	Measure:	
	Note:	Adjustable monitoring (with motor parameters: thermal time constant and reference current) The current value can be read with the "Motor load" status display. An error message is generated for a motor load of 105%.
2312 _h 8978 _d	Error code (hex):	0x2312
	Error:	Effective drive current monitor
	Error reaction:	Reaction 2: Downramp / apply brake / de-energize.
	Measure:	
	Note:	Adjustable monitoring (dependant on device parameters) The current value can be read with object 683.2 or the "Device load" status display.
2320 _h 8992 _d	Error code (hex):	0x2320
	Error:	Overcurrent (power stage)
	Error reaction:	Reaction 5: switch-off of the current immediately (without ramp), application of the brake.
	Measure:	Check motor cable
	Note:	Error cause is a hardware signal
2331 _h 9009 _d	Error code (hex):	0x2331
	Error:	Earth fault phase 1
	Error reaction:	none
	Measure:	
	Note:	not implemented

3210 _h 12816 _d	Error code (hex):	0x3210
	Error:	High Voltage DC exceeds limit
	Error reaction:	Reaction 5: switch-off of the current immediately (without ramp), application of the brake.
	Measure:	Limit value is normalized on object 236.45. Normalization factor 1000V
	Note:	The voltage on the output bus has exceeded the maximum permissible value
3222 _h 12834 _d	Error code (hex):	0x3222
	Error:	High voltage DC too low (<70V)
	Error reaction:	Reaction 2: Downramp / apply brake / de-energize.
	Measure:	
	Note:	Measurement via PAP
4210 _h 16912 _d	Error code (hex):	0x4210
	Error:	Power output stage / device temperature > 85 C
	Error reaction:	Reaction 2: Downramp / apply brake / de-energize.
	Measure:	
	Note:	Measurement via PAP; source from power stage
4310 _h 17168 _d	Error code (hex):	0x4310
	Error:	Motor temp.
	Error reaction:	Reaction 2: Downramp / apply brake / de-energize.
	Measure:	
	Note:	Source is motor temperature signal
5111 _h 20753 _d	Error code (hex):	0x5111
	Error:	Auxiliary Voltage 15V faulty
	Error reaction:	Reaction 2: Downramp / apply brake / de-energize.
	Measure:	
	Note:	Measurement via PAP
5112 _h 20754 _d	Error code (hex):	0x5112
	Error:	Overvoltage on 24V Control (X4/1 pin)
	Error reaction:	Reaction 2: Downramp / apply brake / de-energize.
	Measure:	
	Note:	Measurement via PAP
5116 _h 20758 _d	Error code (hex):	0x5116
	Error:	Undervoltage on 24V Control (X4/1 pin)
	Error reaction:	Reaction 2: Downramp / apply brake / de-energize.
	Measure:	
	Note:	Measurement via PAP
5117 _h 20759 _d	Error code (hex):	0x5117
	Error:	Undervoltage - Additional I/O option
	Error reaction:	none
	Measure:	
	Note:	Used for M expansion with I/O if the external power supply is missing
5380 _h 21376 _d	Error code (hex):	0x5380
	Error:	Short Circuit on Digital Output
	Error reaction:	Reaction 2: Downramp / apply brake / de-energize.
	Measure:	
	Note:	Applies to the 4 on-board outputs
5420 _h 21536 _d	Error code (hex):	0x5420
	Error:	Braking Resistor overloaded (Peak Current)
	Error reaction:	Reaction 5: switch-off of the current immediately (without ramp), application of the brake.
	Measure:	
	Note:	Setting via tool input
5421 _h 21537 _d	Error code (hex):	0x5421
	Error:	Braking Resistor overloaded (Continuous Current)
	Error reaction:	Reaction 5: switch-off of the current immediately (without ramp), application of the brake.
	Measure:	
	Note:	Setting via tool input

5480 _n 21632 _d	Error code (hex):	0x5480
	Error:	Short Circuit - Motor Brake
	Error reaction:	none
	Measure:	
	Note:	Diagnostic lines from power stage interface
5481 _n 21633 _d	Error code (hex):	0x5481
	Error:	Open Circuit - Motor Brake
	Error reaction:	none
	Measure:	
	Note:	Diagnostic lines from power stage interface
5491 _n 21649 _d	Error code (hex):	0x5491
	Error:	Disable pow.st.
	Error reaction:	Reaction 5: switch-off of the current immediately (without ramp), application of the brake.
	Measure:	
	Note:	Hardware input (safe standstill)
54A0 _n 21664 _d	Error code (hex):	0x54A0
	Error:	Limit switch I5 (X12/12) activated
	Error reaction:	Reaction 2: Downramp / apply brake / de-energize.
	Measure:	Move axis into the travel range. The error may occur if E5 is designed as a freely assignable input and for example C3_ErrorMask is used in the IEC-program.
	Note:	Limit switch on input 5 is active. Is only set with rising edge.
54A1 _n 21665 _d	Error code (hex):	0x54A1
	Error:	Limit switch I6 (X12/13) activated
	Error reaction:	Reaction 2: Downramp / apply brake / de-energize.
	Measure:	Move axis into the tavel range. The error may occur if E6 is designed as a freely assignable input and for example C3_ErrorMask is used in the IEC program.
	Note:	Limit switch on input 6 is active. Is only set with rising edge.
6011 _n 24593 _d	Error code (hex):	0x6011
	Error:	Runtime overflow 31.25us
	Error reaction:	Reaction 2: Downramp / apply brake / de-energize.
	Measure:	
	Note:	
6012 _n 24594 _d	Error code (hex):	0x6012
	Error:	Runtime overflow 500us
	Error reaction:	Reaction 2: Downramp / apply brake / de-energize.
	Measure:	
	Note:	Runtime monitoring. Internal error
6280 _n 25216 _d	Error code (hex):	0x6280
	Error:	IEC61131-3 Division by zero
	Error reaction:	Reaction 2: Downramp / apply brake / de-energize.
	Measure:	Debug IEC program
	Note:	Division by zero occurred in the IEC program. Execution is aborted at this point and the cycle is restarted after the selected cycle time.
6281 _n 25217 _d	Error code (hex):	0x6281
	Error:	IEC61131-3 Cycle time exceeded
	Error reaction:	Reaction 2: Downramp / apply brake / de-energize.
	Measure:	Optimize program (runtime), increase target cycle time, suppress time-intensive processes (for example saving objects in Flash)
	Note:	Preset nominal cycle time could not be kept. Execution is aborted and the cycle is restarted after the selected cycle time.
6282 _n 25218 _d	Error code (hex):	0x6282
	Error:	IEC61131-3 program stack overflow
	Error reaction:	Reaction 2: Downramp / apply brake / de-energize.
	Measure:	Reduce nesting depth in function and subprogram calls
	Note:	Stack overflow in IEC runtime. Execution is aborted at this point and the cycle is restarted after the selected cycle time.

6283 _h 25219 _d	Error code (hex):	0x6283
	Error:	IEC61131-3 FB overflow
	Error reaction:	Reaction 2: Downramp / apply brake / de-energize.
	Measure:	Reduce the number of or the nesting depth of function module instances
	Note:	Stack overflow in the IEC runtime caused by too many function module entities. Execution is aborted at this point and the cycle is restarted after the selected cycle time.
6284 _h 25220 _d	Error code (hex):	0x6284
	Error:	IEC61131-3 illegal instruction
	Error reaction:	Reaction 2: Downramp / apply brake / de-energize.
	Measure:	Recompile the program / download and verify the compiler version
	Note:	Invalid opcode in the IEC program Execution is aborted at this point and the cycle is restarted after the selected cycle time.
7121 _h 28961 _d	Error code (hex):	0x7121
	Error:	Motor stalled
	Error reaction:	Reaction 5: switch-off of the current immediately (without ramp), application of the brake.
	Measure:	
	Note:	Speed controller signal at limit for specific time
7180 _h 29056 _d	Error code (hex):	0x7180
	Error:	Motor Peak Current monitor
	Error reaction:	Reaction 2: Downramp / apply brake / de-energize.
	Measure:	
	Note:	Adjustable monitoring (with motor parameters: pulse current time and pulse current) The current value can be read with the "Motor impulse utilization" status display. An error message is generated for a motor impulse utilization of 115%.
7310 _h 29456 _d	Error code (hex):	0x7310
	Error:	Speed too high
	Error reaction:	Reaction 5: switch-off of the current immediately (without ramp), application of the brake.
	Measure:	
	Note:	Speed too high
7320 _h 29472 _d	Error code (hex):	0x7320
	Error:	Tracking error
	Error reaction:	Reaction 2: Downramp / apply brake / de-energize.
	Measure:	Optimize controller adjustment (increase stiffness), increase tracking error window and / or tracking error time
	Note:	Monitoring of tracking error window incl. time
7323 _h 29475 _d	Error code (hex):	0x7323
	Error:	Target position beyond positive end limit
	Error reaction:	Reaction 2: Downramp / apply brake / de-energize.
	Measure:	Software end limits exceeded. After that only movements towards the travel range are permitted. Cam, Gear, Current are blocked. Only effective, if home is reached (axis is referenced).
	Note:	Software end limits exceeded. After that only movements towards the travel range are permitted. Cam, Gear, Current are blocked. Only effective, if home is reached (axis is referenced).
7324 _h 29476 _d	Error code (hex):	0x7324
	Error:	Target position beyond negative end limit
	Error reaction:	Reaction 2: Downramp / apply brake / de-energize.
	Measure:	Software end limits exceeded. After that only movements towards the travel range are permitted. Cam, Gear, Current are blocked. Only effective, if home is reached (axis is referenced).
	Note:	Software end limits exceeded. After that only movements towards the travel range are permitted. Cam, Gear, Current are blocked. Only effective, if home is reached (axis is referenced).

7381 _n 29569 _d	Error code (hex):	0x7381
	Error:	Resolver output level too high
	Error reaction:	Reaction 2: Downramp / apply brake / de-energize.
	Measure:	Check feedback cable or feedback Note: The feedback excitation voltage is deactivated for level errors!
	Note:	Level limit exceeded, can only be reset by powering on the device again.
7382 _n 29570 _d	Error code (hex):	0x7382
	Error:	Resolver output level too low
	Error reaction:	Reaction 2: Downramp / apply brake / de-energize.
	Measure:	Check feedback cable or feedback Note: The feedback excitation voltage is deactivated for level errors!
	Note:	Level has fallen below limit, can only be reset by powering on the device again.
7391 _n 29585 _d	Error code (hex):	0x7391
	Error:	Feedback level exceeds limit
	Error reaction:	Reaction 2: Downramp / apply brake / de-energize.
	Measure:	Check feedback cable (shield, abort, short-circuit) or feedback Note: The feedback power supply voltage is deactivated for F11!
	Note:	SinCos feedback/Encoder: Level of the Sine/Cosine trace too high; can only be reset by powering on the device again. The limit for Firmware >V2.x.x is at the physical limit 2.5Vss.
7392 _n 29586 _d	Error code (hex):	0x7392
	Error:	Feedback level too low
	Error reaction:	Reaction 2: Downramp / apply brake / de-energize.
	Measure:	Check feedback cable (shield, abort, short-circuit) or feedback Note: The feedback power supply voltage is deactivated for F11!
	Note:	SinCos feedback/Encoder: Level of Sine/Cosine or A/B trace too low, can only be reset by powering on the device again The limit for Firmware >V2.x.x is at 0.4Vss. With RS422 feedback one or both traces are missing.
73A0 _n 29600 _d	Error code (hex):	0x73A0
	Error:	Hall commutation: invalid combination of hall signals
	Error reaction:	Reaction 5: switch-off of the current immediately (without ramp), application of the brake.
	Measure:	Check hall wiring and hall sensors for functionality. Eliminate any (EMC) malfunctions in hall signals.
	Note:	A hall combination that is not permitted with correct wiring was recorded during hall commutating. Can only be reset by PowerOn.
73A1 _n 29601 _d	Error code (hex):	0x73A1
	Error:	Hall commutation: invalid correction value fine angle
	Error reaction:	Reaction 2: Downramp / apply brake / de-energize.
	Measure:	Configure hall direction correctly (check with Motormanager). (EMC) Eliminate disturbance on hall signals. Check hall wiring and verify function of hall sensors.
	Note:	The difference between rough and fine commutation detected is higher than the maximum value 30 electric. Can be acknowledged by PowerOn.
73A5 _n 29605 _d	Error code (hex):	0x73A5
	Error:	Automatic commutation: no standstill of drive on start
	Error reaction:	Reaction 2: Downramp / apply brake / de-energize.
	Measure:	Check the signal quality of the feedback (noise), bring the drive to a standstill
	Note:	(Filtered) speed of the motor within 10 s after the start of automatic commutation not zero
73A6 _n 29606 _d	Error code (hex):	0x73A6
	Error:	Automatic commutation: More than 60° el. movement
	Error reaction:	Reaction 2: Downramp / apply brake / de-energize.
	Measure:	Malfunction (motion caused by external source) of the motor during automatic commutation, starting current too great, incorrect parameter for commutation direction (use MotorManager to determine the values). Check feedback resolution and/or number of feedback or motor poles.
	Note:	The motor has moved more than permitted during automatic commutation.

73A7_h 29607_d	Error code (hex):	0x73A7
	Error:	Automatic commutation: More than 5° el. movement during phase 2
	Error reaction:	Reaction 2: Downramp / apply brake / de-energize.
	Measure:	Eliminate external influence on the motor or device current is too small resp. friction is too great.
	Note:	Motor is not following controlled movement. In this case, the motor should stand still.
73A8_h 29608_d	Error code (hex):	0x73A8
	Error:	Automatic commutation: No standstill during phase 3
	Error reaction:	Reaction 2: Downramp / apply brake / de-energize.
	Measure:	Eliminate external influence on the motor. Check feedback.
	Note:	The motor is not following controlled movement (here: Motor does not stop)
73A9_h 29609_d	Error code (hex):	0x73A9
	Error:	Automatic commutation: Timeout during phase 3
	Error reaction:	Reaction 2: Downramp / apply brake / de-energize.
	Measure:	Increase the starting current and eliminate very high direction dependence or friction if any. Check feedback resolution and/or number of feedback or motor poles.
	Note:	The maximum time for automatic commutation has been exceeded.
73AA_h 29610_d	Error code (hex):	0x73AA
	Error:	Automatic commutation: Too many trials during phase 3
	Error reaction:	Reaction 2: Downramp / apply brake / de-energize.
	Measure:	Increase the starting current or eliminate external influence on the motor. Check feedback resolution and/or number of feedback or motor poles.
	Note:	The motor is not following assigned controlled movement.
73AB_h 29611_d	Error code (hex):	0x73AB
	Error:	Automatic commutation: Timeout
	Error reaction:	Reaction 2: Downramp / apply brake / de-energize.
	Measure:	Increase automatic commutation starting current, eliminate motor block, check parameters for motor current (too small, device extremely under-dimensioned), current controller unstable.
	Note:	It was not possible to successfully complete automatic commutation within 30 s.
73AC_h 29612_d	Error code (hex):	0x73AC
	Error:	Automatic commutation: No motor connected
	Error reaction:	Reaction 2: Downramp / apply brake / de-energize.
	Measure:	Connect motor resp. check wiring
	Note:	Current controller setting full voltage without current flowing.
73B0_h 29616_d	Error code (hex):	0x73B0
	Error:	Distance coding: invalid reference mark position
	Error reaction:	Reaction 2: Downramp / apply brake / de-energize.
	Measure:	Checking and correcting the feedback sensor adjustment as well as the feedback wiring
	Note:	The position of the reference mark (middle of mark) with reference to the fine interpolation (Sine and Cosine) is not in the range -89.9..179.9 .
7480_h 29824_d	Error code (hex):	0x7480
	Error:	Cam generator: invalid segment in linking table
	Error reaction:	Reaction 2: Downramp / apply brake / de-energize.
	Measure:	Check segment entries of the linking table and/or verify the contents of the curve header / memory.
	Note:	The segment entered into the linking table row (linking direction taken into consideration) currently processed or one of the following rows up to the next end segment, is not available in the curve memory (> number of curves in the header or not set in the flash).

7481 _n 29825 _d	Error code (hex):	0x7481
	Error:	Cam generator: invalid master segment distance
	Error reaction:	Reaction 2: Downramp / apply brake / de-energize.
	Measure:	Verify master segment distances and/or master segment factors in the linking table.
	Note:	The master segment distance assigned to the currently processed linking table row or to the following linking table row up to the next end segment (linking direction taken into consideration) is permitted (segment distance or factor <=0).
7482 _n 29826 _d	Error code (hex):	0x7482
	Error:	Cam generator: cam point not found
	Error reaction:	none
	Measure:	Verify configuration of the master channel (normalization), verify master segment distance and/or factor (too small?), if needs be, reduce number of interpolation points of the curve.
	Note:	The curve point belonging to the current relative master position in the current segment could not be found, as the scanning area is too small.
7483 _n 29827 _d	Error code (hex):	0x7483
	Error:	Cam generator: cam data error
	Error reaction:	Reaction 2: Downramp / apply brake / de-energize.
	Measure:	Verify normalized master positions in the flash.
	Note:	The difference between the master positions of two successive curve points in the flash is smaller or equal to zero.
7484 _n 29828 _d	Error code (hex):	0x7484
	Error:	Cam generator: cam point of coupling segment not found
	Error reaction:	Reaction 2: Downramp / apply brake / de-energize.
	Measure:	as 7482 but with coupling segment
	Note:	as 7482 but with coupling segment
7485 _n 29829 _d	Error code (hex):	0x7485
	Error:	Cam generator: cam data coupling segment error
	Error reaction:	Reaction 2: Downramp / apply brake / de-energize.
	Measure:	as 7483 but with coupling segment
	Note:	as 7483 but with coupling segment
7486 _n 29830 _d	Error code (hex):	0x7486
	Error:	Cam generator: multiple segment change
	Error reaction:	Reaction 2: Downramp / apply brake / de-energize.
	Measure:	Verify configuration of the master channel (normalization), verify master segment distance and/or factor (too small?).
	Note:	The current configuration demands that more than one change of segment would be necessary in 500us. This is however not possible..
7487 _n 29831 _d	Error code (hex):	0x7487
	Error:	Cam generator: maximum allowable master or slave speed value exceeded
	Error reaction:	Reaction 2: Downramp / apply brake / de-energize.
	Measure:	Master and slave normalization, verify master and slave factors as well as master or slave segment distances, reduce master velocity.
	Note:	The master speed / slave speed exceeds 2 ²³ .
7488 _n 29832 _d	Error code (hex):	0x7488
	Error:	Cam generator: maximum allowable internal speed value exceeded
	Error reaction:	Reaction 2: Downramp / apply brake / de-energize.
	Measure:	Verify or modify configuration.
	Note:	Value range overflow in curve operation. The selected configuration is not possible.
7590 _n 30096 _d	Error code (hex):	0x7590
	Error:	HEDA synchronization error
	Error reaction:	Reaction 2: Downramp / apply brake / de-energize.
	Measure:	Check HEDA cable. Are the terminating connectors correctly fixed? Is the red HEDA-LED off on all devices? Is there a Master and are all of ist transmit slots active?
	Note:	HEDA connection is interrupted. No valid telegrams could be detected.

7591 _n 30097 _d	Error code (hex):	0x7591
	Error:	HEDA communication error
	Error reaction:	Reaction 2: Downramp / apply brake / de-energize.
	Measure:	Check HEDA cable. Are the terminating connectors correctly fixed? Could double assignments in a transmit slot lead to collisions? Watch HEDA-LED!
	Note:	HEDA-CRC-Error. Error within a telegram.
7594 _n 30100 _d	Error code (hex):	0x7594
	Error:	HEDA receiver overrun
	Error reaction:	Reaction 2: Downramp / apply brake / de-energize.
	Measure:	
	Note:	HEDA
8110 _n 33040 _d	Error code (hex):	0x8110
	Error:	Overrun
	Error reaction:	none
	Measure:	
	Note:	Field bus error: adjustable response (none, response 2)
8120 _n 33056 _d	Error code (hex):	0x8120
	Error:	CRC error or passive mode (CAN)
	Error reaction:	none
	Measure:	
	Note:	Field bus error: adjustable response (none, response 2)
8121 _n 33057 _d	Error code (hex):	0x8121
	Error:	Bus off (CAN)
	Error reaction:	none
	Measure:	
	Note:	CAN Bus inactive status Field bus error: adjustable response (none, response 2)
8131 _n 33072 _d	Error code (hex):	0x8131
	Error:	Fieldbus synchronization error
	Error reaction:	none
	Measure:	Check connection and master
	Note:	Failure of the sync telegram Field bus error: adjustable response (none, response 2)
8181 _n 33153 _d	Error code (hex):	0x8181
	Error:	Invalid velocity
	Error reaction:	none
	Measure:	Reduce setpoint value
	Note:	Preset speed ins too high (also externally); command was rejected
8182 _n 33154 _d	Error code (hex):	0x8182
	Error:	CAM command error
	Error reaction:	Reaction 2: Downramp / apply brake / de-energize.
	Measure:	
	Note:	
8183 _n 33155 _d	Error code (hex):	0x8183
	Error:	Watchdog test movement
	Error reaction:	Reaction 2: Downramp / apply brake / de-energize.
	Measure:	Acknowledge Error occurs for example if the response times of the PC are too long for RS232 communication.
	Note:	Error is triggered if o40.3=0. Watchdog cannot be deactivated via o40.3=-1. Watchdog time=o40.3*100ms

8190_n 33168_d	Error code (hex):	0x8190
	Error:	CamCommand: unknown command
	Error reaction:	Reaction 2: Downramp / apply brake / de-energize.
	Measure:	Only emit commands that are possible: 1: SetC, 2: SetM (on O3011.1), 3: SetM on current input position of the master position acquisition (on O3021.2), 4: prepare coupling/decoupling by change-over, 5: prepare quadratic coupling, 6: prepare quadratic decoupling. As from Firmware version V02.05.02: 10: Setting the displayed master position, 11: Setting the master position for the curve in mode "relative", 12: Setting the master position for the curve in mode "absolute", 20: Cache segment data again
	Note:	The preset Cam command does not exist.
8191_n 33169_d	Error code (hex):	0x8191
	Error:	CamCommand: SetC must be executed before SetM
	Error reaction:	Reaction 2: Downramp / apply brake / de-energize.
	Measure:	Please take the order of the commands SetC and SetM into consideration.
	Note:	SetC (Cmd 1) must have been executed before SetM (Cmd 2).
8192_n 33170_d	Error code (hex):	0x8192
	Error:	CamCommand: command not permitted at present
	Error reaction:	Reaction 2: Downramp / apply brake / de-energize.
	Measure:	Create the prerequisites for the command: SetM (Cmd 2,3) only if "global enable" (O3020.4) is not placed. Prepare coupling by change-over (Cmd 4) only if coupling / decoupling is not taking place at the same time. Prepare quadratic coupling (Cmd 5) only if coupling is not taking place at the same time and if SetM has already been executed. Prepare quadratic decoupling (Cmd 6) only if coupling is not taking place at the same time and if SetM has already been executed. Set master position for display (Cmd10) only if not synchronized (coupling or decoupling resp. curve mode). Set master position in Mode relative/absolute (Cmd11/12) only without master position enable for Cam (O3032.7 = 0).
	Note:	The selected command is not permitted at present.
8193_n 33171_d	Error code (hex):	0x8193
	Error:	CamCommand: invalid table row entry for the selected cam
	Error reaction:	Reaction 2: Downramp / apply brake / de-energize.
	Measure:	Correct specification for selected curve (O3011.2) and/or start line of the curve (O3040).
	Note:	The table row assigned to the selected curve (=3040.(O3011.2)) for SetC (Cmd1,11,12) is invalid (smaller or equal to zero or greater than the maximum number of rows of 20).
8194_n 33172_d	Error code (hex):	0x8194
	Error:	CamCommand: invalid coupling segment
	Error reaction:	Reaction 2: Downramp / apply brake / de-energize.
	Measure:	Select valid coupling segment (O3011.3) or verify curve memory.
	Note:	Prepare coupling by change-over (Cmd 4): The coupling segment chosen in O3011.3 is invalid, as it is not available in the curve memory.
8195_n 33173_d	Error code (hex):	0x8195
	Error:	CamCommand: invalid segment
	Error reaction:	Reaction 2: Downramp / apply brake / de-energize.
	Measure:	Select valid segment or verify curve memory.
	Note:	The coupling segment to be processed next is invalid, as it is not available in the curve memory. Additional information in the current table row (O3010.4) and in the current segment (O3010.5).
8196_n 33174_d	Error code (hex):	0x8196
	Error:	CamCommand: invalid master segment distance
	Error reaction:	Reaction 2: Downramp / apply brake / de-energize.
	Measure:	Specify permitted value for master segment distance (O3056) or master segment factor (O3058).
	Note:	The master segment distance to be processed next is smaller or equal to zero. This is not permitted. Additional information in the current table row (O3010.4) and in the current segment (O3010.5).

8197 _h 33175 _d	Error code (hex):	0x8197
	Error:	CamCommand: invalid segment figure in cam memory
	Error reaction:	Reaction 2: Downramp / apply brake / de-energize.
	Measure:	Verify header or reduce number of segments.
	Note:	The number of segments stated in the curve header exceeds the maximum value of 354 (without default coupling segment).
8199 _h 33177 _d	Error code (hex):	0x8199
	Error:	CamCommand: internal value range overflow
	Error reaction:	Reaction 2: Downramp / apply brake / de-energize.
	Measure:	Verify, if the configuration used makes sense. Send the configuration and cam data to technical support.
	Note:	Internal calculation problem when processing the curve data.
819a _h 33178 _d	Error code (hex):	0x819a
	Error:	CamCommand: invalid slope of quadratic coupling
	Error reaction:	Reaction 2: Downramp / apply brake / de-energize.
	Measure:	Verify the current segment (O3031.1) and its sequence, the selected coupling / decoupling positions (O1139.1 and =1140.1) and the selected delta values (O1129.4 and =1140.4)
	Note:	The slope calculated when preparing the quadratic coupling and decoupling (Cmd 5,6) is invalid (smaller than or equal to zero).
819b _h 33179 _d	Error code (hex):	0x819b
	Error:	CamCommand: invalid parameters for changing of master reset distance
	Error reaction:	Reaction 2: Downramp / apply brake / de-energize.
	Measure:	Verify the default values numerator (O3011.5) and/or denominator of the reset distance. Verify the configuration of master and master signal sources.
	Note:	The default values numerator (O3011.5) and/or denominator of the reset distance (O3011.6) are invalid (smaller than zero or larger or equal to 2 ²³) or, with alternative reset distance: Denominator path/(master*numerator reset distance * numerator alternative reset distance (O3011.5) is larger than or equal to 2 ⁴⁷ .
819c _h 33180 _d	Error code (hex):	0x819c
	Error:	CamCommand: invalid master source selected
	Error reaction:	Reaction 2: Downramp / apply brake / de-energize.
	Measure:	Select valid source for switching or configure source to switch to.
	Note:	The master source selected in =3011.8 is invalid or was not configured.
8612 _h 34322 _d	Error code (hex):	0x8612
	Error:	Reference Limit
	Error reaction:	Reaction 2: Downramp / apply brake / de-energize.
	Measure:	Reference position could not be accessed. One of the limit switches was detected twice. There was no home switch or feedback zero pulse. Homing was aborted
	Note:	No reference point for machine zero detected within the travel range. The homing sequence was aborted. Check reference point feedback.
FF01 _h 65281 _d	Error code (hex):	0xFF01
	Error:	No object with this index available
	Error reaction:	none
	Measure:	
	Note:	Object does not exist
FF02 _h 65282 _d	Error code (hex):	0xFF02
	Error:	No object with this subindex available
	Error reaction:	none
	Measure:	
	Note:	the chosen subindex for this object does not exist
FF03 _h 65283 _d	Error code (hex):	0xFF03
	Error:	Object is "read only"
	Error reaction:	none
	Measure:	
	Note:	No write access

FF04_h 65284_d	Error code (hex):	0xFF04
	Error:	Object cannot be read
	Error reaction:	none
	Measure:	
	Note:	No read access
FF05_h 65285_d	Error code (hex):	0xFF05
	Error:	Version conflict; object data not valid in flash
	Error reaction:	none
	Measure:	
	Note:	Internal error
FF06_h 65286_d	Error code (hex):	0xFF06
	Error:	No object for process data; object cannot be mapped
	Error reaction:	none
	Measure:	
	Note:	This object cannot be mapped on the cyclic data
FF07_h 65287_d	Error code (hex):	0xFF07
	Error:	Data not valid
	Error reaction:	none
	Measure:	
	Note:	No OPM text present
FF08_h 65288_d	Error code (hex):	0xFF08
	Error:	No convert function
	Error reaction:	none
	Measure:	
	Note:	Internal error
FF10_h 65296_d	Error code (hex):	0xFF10
	Error:	Command syntax error
	Error reaction:	none
	Measure:	
	Note:	Syntax error
FF11_h 65297_d	Error code (hex):	0xFF11
	Error:	Value not valid
	Error reaction:	none
	Measure:	
	Note:	Argument incorrect
FF12_h 65298_d	Error code (hex):	0xFF12
	Error:	Checksum error
	Error reaction:	none
	Measure:	
	Note:	Checksum CRC incorrect
FF13_h 65299_d	Error code (hex):	0xFF13
	Error:	Timeout error
	Error reaction:	none
	Measure:	
	Note:	Active in binary protocol; 5 ms
FF14_h 65300_d	Error code (hex):	0xFF14
	Error:	Overflow error
	Error reaction:	none
	Measure:	
	Note:	Utype error
FF15_h 65301_d	Error code (hex):	0xFF15
	Error:	Parity error
	Error reaction:	none
	Measure:	
	Note:	Utype error

FF16_h 65302_d	Error code (hex):	0xFF16
	Error:	Frame error
	Error reaction:	none
	Measure:	
	Note:	Utype error
FF20_h 65312_d	Error code (hex):	0xFF20
	Error:	Flash sector delete failed
	Error reaction:	none
	Measure:	
	Note:	Error while deleting flash
FF21_h 65313_d	Error code (hex):	0xFF21
	Error:	Program flash cell failed
	Error reaction:	none
	Measure:	
	Note:	Error while programming flash
FF22_h 65314_d	Error code (hex):	0xFF22
	Error:	Checksum error of prog. Flash area
	Error reaction:	none
	Measure:	
	Note:	Error for flash checksum
FF23_h 65315_d	Error code (hex):	0xFF23
	Error:	DOWN/UPLOAD activated
	Error reaction:	none
	Measure:	
	Note:	Download or upload is active
FF24_h 65316_d	Error code (hex):	0xFF24
	Error:	DOWN/UPLOAD not activated
	Error reaction:	none
	Measure:	
	Note:	Download or upload is inactive
FF30_h 65328_d	Error code (hex):	0xFF30
	Error:	EEPROM Delay Count Error
	Error reaction:	none
	Measure:	
	Note:	Internal error
FF40_h 65344_d	Error code (hex):	0xFF40
	Error:	Not enough memory for OSZI or AWL reserved
	Error reaction:	none
	Measure:	
	Note:	An attempt was made to reserve too much memory (IEC, osci)
FF42_h 65346_d	Error code (hex):	0xFF42
	Error:	No objects available
	Error reaction:	none
	Measure:	Load application data into device (objects)
	Note:	Application data error; no valid objects present LED red flashing
FF43_h 65347_d	Error code (hex):	0xFF43
	Error:	No IEC61131 program
	Error reaction:	none
	Measure:	Load application data into device (IEC61131 program). Turn device off and back on again.
	Note:	Application data error; no IEC61131 program available LED red flashing

FF45_h 65349_d	Error code (hex):	0xFF45
	Error:	No FBI
	Error reaction:	none
	Measure:	De-energize motor, then perform function
	Note:	Motor is energized! An attempt was made to execute a function at a time when the motor must be de-energized, e.g. device duplication via BDM.
FF46_h 65350_d	Error code (hex):	0xFF46
	Error:	Motor powered
	Error reaction:	none
	Measure:	
	Note:	An attempt was made to perform a device duplication even though the source and target device are different (different order code)
FF47_h 65351_d	Error code (hex):	0xFF47
	Error:	Devicetype dif
	Error reaction:	none
	Measure:	
	Note:	The hardware of the source is not compatible with the hardware of the target for duplicating a device
FF60_h 65376_d	Error code (hex):	0xFF60
	Error:	CANopen library
	Error reaction:	none
	Measure:	
	Note:	
FF61_h 65377_d	Error code (hex):	0xFF61
	Error:	CANopen confirmation
	Error reaction:	none
	Measure:	CANopen Master did not receive a confirmation from the accessed CANopen node
	Note:	
FF62_h 65378_d	Error code (hex):	0xFF62
	Error:	No CANopen Master
	Error reaction:	none
	Measure:	
	Note:	
FF90_h 65424_d	Error code (hex):	0xFF90
	Error:	Feedback System isn't compatible to the Compax3 Feedback Option
	Error reaction:	none
	Measure:	„Replace“ or update firmware, use device required for feedback.
	Note:	The connected feedback system cannot be used with the firmware currently in use. (for example with commutation wizard F12 feedback for F10/F11 device and vice-versa).
FF91_h 65425_d	Error code (hex):	0xFF91
	Error:	Invalid combination of hall signals rough commutation
	Error reaction:	none
	Measure:	Check hall wiring and hall sensors for functionality. Eliminate any (EMC) malfunctions in hall signals.
	Note:	Invalid hall combinations "000" or "111" were detected during hall commutation.
FF92_h 65426_d	Error code (hex):	0xFF92
	Error:	Invalid commutation
	Error reaction:	none
	Measure:	Switch device off and on again or execute commands 9 and 10 one after the other.
	Note:	Only with F12 devices: Compax3 must be re-started, as the commutation or the configured motor was changed due to a configuration download. The error cannot be acknowledged.

FFA1_n 65441_d	Error code (hex):	0xFFA1
	Error:	SinCos Analog signals outside specification
	Error reaction:	Reaction 2: Downramp / apply brake / de-energize.
	Measure:	Change feedback
	Note:	Feedback reports error
FFA2_n 65442_d	Error code (hex):	0xFFA2
	Error:	SinCos Internal angle offset fault
	Error reaction:	Reaction 2: Downramp / apply brake / de-energize.
	Measure:	Change feedback
	Note:	Feedback reports error
FFA3_n 65443_d	Error code (hex):	0xFFA3
	Error:	SinCos Table destroyed via data field partition
	Error reaction:	Reaction 2: Downramp / apply brake / de-energize.
	Measure:	Change feedback
	Note:	Feedback reports error
FFA4_n 65444_d	Error code (hex):	0xFFA4
	Error:	SinCos Analog limits not available
	Error reaction:	Reaction 2: Downramp / apply brake / de-energize.
	Measure:	Change feedback
	Note:	Feedback reports error
FFA5_n 65445_d	Error code (hex):	0xFFA5
	Error:	SinCos Internal I ² C-Bus not functioning I ² T?
	Error reaction:	Reaction 2: Downramp / apply brake / de-energize.
	Measure:	Change feedback
	Note:	Feedback reports error
FFA6_n 65446_d	Error code (hex):	0xFFA6
	Error:	SinCos Internal checksum error
	Error reaction:	Reaction 2: Downramp / apply brake / de-energize.
	Measure:	Change feedback
	Note:	Feedback reports error
FFA7_n 65447_d	Error code (hex):	0xFFA7
	Error:	SinCos Feedback reset via program supervision
	Error reaction:	Reaction 2: Downramp / apply brake / de-energize.
	Measure:	Change feedback
	Note:	Feedback reports error
FFA8_n 65448_d	Error code (hex):	0xFFA8
	Error:	SinCos Counter overflow
	Error reaction:	Reaction 2: Downramp / apply brake / de-energize.
	Measure:	Change feedback
	Note:	Feedback reports error
FFA9_n 65449_d	Error code (hex):	0xFFA9
	Error:	SinCos Parity error
	Error reaction:	Reaction 2: Downramp / apply brake / de-energize.
	Measure:	Change feedback
	Note:	Feedback reports error
FFAA_n 65450_d	Error code (hex):	0xFFAA
	Error:	SinCos Checksum of transmitted data is faulty
	Error reaction:	Reaction 2: Downramp / apply brake / de-energize.
	Measure:	Change feedback
	Note:	Feedback reports error
FFAB_n 65451_d	Error code (hex):	0xFFAB
	Error:	SinCos Unknown command code
	Error reaction:	Reaction 2: Downramp / apply brake / de-energize.
	Measure:	Change feedback
	Note:	Feedback reports error

FFAC_n 65452_d	Error code (hex):	0xFFAC
	Error:	SinCos Number of transmitted data is faulty
	Error reaction:	Reaction 2: Downramp / apply brake / de-energize.
	Measure:	Change feedback
	Note:	Feedback reports error
FFAD_n 65453_d	Error code (hex):	0xFFAD
	Error:	SinCos Improper command argument transmitted
	Error reaction:	Reaction 2: Downramp / apply brake / de-energize.
	Measure:	Change feedback
	Note:	Feedback reports error
FFAE_n 65454_d	Error code (hex):	0xFFAE
	Error:	SinCos the selected data field is not to be exceeded
	Error reaction:	Reaction 2: Downramp / apply brake / de-energize.
	Measure:	Change feedback
	Note:	Feedback reports error
FFAF_n 65455_d	Error code (hex):	0xFFAF
	Error:	SinCos Invalid access code
	Error reaction:	Reaction 2: Downramp / apply brake / de-energize.
	Measure:	Change feedback
	Note:	Feedback reports error
FFB0_n 65456_d	Error code (hex):	0xFFB0
	Error:	SinCos size of given data field cannot be changed
	Error reaction:	Reaction 2: Downramp / apply brake / de-energize.
	Measure:	Change feedback
	Note:	Feedback reports error
FFB1_n 65457_d	Error code (hex):	0xFFB1
	Error:	SinCos given word address outside data field
	Error reaction:	Reaction 2: Downramp / apply brake / de-energize.
	Measure:	Change feedback
	Note:	Feedback reports error
FFB2_n 65458_d	Error code (hex):	0xFFB2
	Error:	SinCos access to non-existing data field. data field
	Error reaction:	Reaction 2: Downramp / apply brake / de-energize.
	Measure:	Change feedback
	Note:	Feedback reports error
FFBC_n 65468_d	Error code (hex):	0xFFBC
	Error:	SinCos Absolute value control of the analog signals
	Error reaction:	Reaction 2: Downramp / apply brake / de-energize.
	Measure:	Change feedback
	Note:	Feedback reports error
FFBD_n 65469_d	Error code (hex):	0xFFBD
	Error:	SinCos Transmitter current approaching limit
	Error reaction:	Reaction 2: Downramp / apply brake / de-energize.
	Measure:	Change feedback
	Note:	Feedback reports error
FFBE_n 65470_d	Error code (hex):	0xFFBE
	Error:	SinCos Feedback temperature approaching limit
	Error reaction:	Reaction 2: Downramp / apply brake / de-energize.
	Measure:	Change feedback
	Note:	Feedback reports error
FFBF_n 65471_d	Error code (hex):	0xFFBF
	Error:	SinCos Speed exceeds normal, no position generation permitted
	Error reaction:	Reaction 2: Downramp / apply brake / de-energize.
	Measure:	Change feedback
	Note:	Feedback reports error

FFC0_h 65472_d	Error code (hex):	0xFFC0
	Error:	SinCos Position Singleturn unreliable
	Error reaction:	Reaction 2: Downramp / apply brake / de-energize.
	Measure:	Change feedback
	Note:	Feedback reports error
FFC1_h 65473_d	Error code (hex):	0xFFC1
	Error:	SinCos Position error Multiturn
	Error reaction:	Reaction 2: Downramp / apply brake / de-energize.
	Measure:	Change feedback
	Note:	Feedback reports error
FFC2_h 65474_d	Error code (hex):	0xFFC2
	Error:	SinCos Position error Multiturn
	Error reaction:	Reaction 2: Downramp / apply brake / de-energize.
	Measure:	Change feedback
	Note:	Feedback reports error
FFC3_h 65475_d	Error code (hex):	0xFFC3
	Error:	SinCos Position error Multiturn
	Error reaction:	Reaction 2: Downramp / apply brake / de-energize.
	Measure:	Change feedback
	Note:	Feedback reports error
FFD0_h 65488_d	Error code (hex):	0xFFD0
	Error:	SinCos CRC
	Error reaction:	Reaction 2: Downramp / apply brake / de-energize.
	Measure:	Check wiring, check feedback Ensure EMC immunity by the aid of correct screening
	Note:	Communication error with SinCos feedback
FFD1_h 65489_d	Error code (hex):	0xFFD1
	Error:	SinCos RX Timeout
	Error reaction:	Reaction 2: Downramp / apply brake / de-energize.
	Measure:	Check wiring, check feedback Ensure EMC immunity by the aid of correct screening
	Note:	Communication error with SinCos feedback
FFD2_h 65490_d	Error code (hex):	0xFFD2
	Error:	SinCos RX Overrun
	Error reaction:	Reaction 2: Downramp / apply brake / de-energize.
	Measure:	Check wiring, check feedback Ensure EMC immunity by the aid of correct screening
	Note:	Communication error with SinCos feedback
FFD3_h 65491_d	Error code (hex):	0xFFD3
	Error:	SinCos RX Parity
	Error reaction:	Reaction 2: Downramp / apply brake / de-energize.
	Measure:	Check wiring, check feedback Ensure EMC immunity by the aid of correct screening
	Note:	Communication error with SinCos feedback
FFD4_h 65492_d	Error code (hex):	0xFFD4
	Error:	SinCos RX Frame
	Error reaction:	Reaction 2: Downramp / apply brake / de-energize.
	Measure:	Check wiring, check feedback Ensure EMC immunity by the aid of correct screening
	Note:	Communication error with SinCos feedback
FFD5_h 65493_d	Error code (hex):	0xFFD5
	Error:	Unknown SinCos encoder type
	Error reaction:	none
	Measure:	Update Compax3 firmware
	Note:	The SinCos feedback sytem type connected is not supported

FFD6_n 65494_d	Error code (hex):	0xFFD6
	Error:	SinCos speed exceeds normal when writing encoder position
	Error reaction:	Reaction 2: Downramp / apply brake / de-energize.
	Measure:	Ensure that the motor is at a standstill
	Note:	The speed when writing the feedback position was too high
FFE0_n 65504_d	Error code (hex):	0xFFE0
	Error:	Homing sequence attempted while moving or drive disabled
	Error reaction:	none
	Measure:	Do not call PLCopen function module MC_Home during an ongoing positioning process or while a stop command is running.
	Note:	Error in the IEC61131-3 program sequence. PLCopen function module MC_home was called even though the axis was not at a standstill (state standstill AND drive energized)
FFE1_n 65505_d	Error code (hex):	0xFFE1
	Error:	CamOut not possible during coupling
	Error reaction:	Reaction 2: Downramp / apply brake / de-energize.
	Measure:	PLCopen function module CamOut cannot be called during coupling process.
	Note:	Error in the IEC61131-3 program sequence. PLCopen function module CamOut was called even though the axis was not yet coupled.
FFE2_n 65506_d	Error code (hex):	0xFFE2
	Error:	invalid parameter transfer when calling up a function block
	Error reaction:	Reaction 2: Downramp / apply brake / de-energize.
	Measure:	Call PLCopen function module with matching parameters.
	Note:	Error in the IEC61131-3 program sequence. Function module was called with incorrect parameters.
FFE3_n 65507_d	Error code (hex):	0xFFE3
	Error:	Coupling // Decoupling only possible with C3_CamIn // Out Mode 0
	Error reaction:	Reaction 2: Downramp / apply brake / de-energize.
	Measure:	Coupling with a linear actuator only possible with Mode 0.
	Note:	Error in the IEC61131-3 program sequence. An attempt was made with a linear actuator to couple with another mode than 0.

8. Compax3 Accessories

In this chapter you can read about:

Order code for Compax3	187
Accessories order code	188
Parker servo motors	191
Connections to the motor	194
EMC measures	199
External ballast resistors	203
Operator control module BDM	206
EAM06: Terminal block for inputs and outputs	206
ZBH plug set	210
Interface cable	211
Input/output option M12	217
HEDA (motion bus) - Option M11	219
HEDA (M11) & I/Os (M12) => Option M10	220

8.1 Order code for Compax3

C3							
Device model:	Single axis	S					
Device currents static	2.5A / 5A / 230V AC (1 phase)	0 2 5	V 2				
	6.3A / 12.6A / 230V AC (1 phase)	0 6 3	V 2				
/ dynamic	10A / 20A / 230V AC (3 phase)	1 0 0	V 2				
/ Supply	15A / 30A / 230V AC (3 phase)	1 5 0	V 2				
voltage :	1.5A / 4.5A / 400V AC (3 phase)	0 1 5	V 4				
	3.8A / 7.5A / 400V AC (3 phase)	0 3 8	V 4				
	7.5 A / 15.0 A / 400 V AC (3-phase)	0 7 5	V 4				
	15.0A / 30.0A / 400V AC (3 phase)	1 5 0	V 4				
	30.0A / 60.0A / 400V AC (3 phase)	3 0 0	V 4				
Feedback:	Resolver		F 1 0				
	SinCos© (Hiperface)		F 1 1				
	Encoder / Sine-cosine with/without hall		F 1 2				
Interface:	Step/direction / analogue input		I 1 0	T 1 0			
	Positioning with inputs/outputs		I 1 1				
	Positioning via I/Os or RS232 / RS485		I 1 2	T 1 1			
	With Profibus DP V0/V1/V2 (12 Mbaud)		I 2 0				
	With CANopen		I 2 1				
	With C3 powerPLmC (Multi-axis control)		C 1 0	T 1 1	- - -		
Technology-Functions:	Positioning			T 1 1			
	Programmable motion control via IEC61131			T 3 0			
	Electronic cam generation			T 4 0			
Options:	Expansion 12 digital I/Os & HEDA (Motionbus)				M 1 0		
	HEDA (Motionbus)				M 1 1		
	Expansion, 12 digital I/Os				M 1 2		

8.2 Accessories order code

Order code for motor cables ²

for SMH / MH56 / MH70 / MH105 ³	(1.5mm ² ; to 13.8A)				M O K 5 5 / ⁽¹⁾
for SMH / MH56 / MH70 / MH105 ³	(1.5mm ² ; to 13.8A)	(cable chain compatible)			M O K 5 4 / ⁽¹⁾
for SMH / MH56 / MH70 / MH105 ³	(2.5mm ² ; to 18.9A)				M O K 5 6 / ⁽¹⁾
for SMH / MH56 / MH70 / MH105 ³	(2.5mm ² ; to 18.9A)	(cable chain compatible)			M O K 5 7 / ⁽¹⁾
for MH145 / MH205 ⁴	(1.5mm ² ; to 13.8A)				M O K 6 0 / ⁽¹⁾
for MH145 / MH205 ⁴	(1.5mm ² ; to 13.8A)	(cable chain compatible)			M O K 6 3 / ⁽¹⁾
for MH145 / MH205 ⁴	(2.5mm ² ; to 18.9A)				M O K 5 9 / ⁽¹⁾
for MH145 / MH205 ⁴	(2.5mm ² ; to 18.9A)	(cable chain compatible)			M O K 6 4 / ⁽¹⁾
for MH145 / MH205 ⁴	(6mm ² ; up to 32.3A)	(cable chain compatible)			M O K 6 1 / ⁽¹⁾
for MH145 / MH205 ⁴	(10mm ² ; up to 47.3A)	(cable chain compatible)			M O K 6 2 / ⁽¹⁾

Order code for feedback cables

for Resolver ²					R E K 4 2 / ⁽¹⁾
for Resolver ²		(cable chain compatible)			R E K 4 1 / ⁽¹⁾
for SinCos® – Feedback devices ²		(cable chain compatible)			G B K 2 4 / ⁽¹⁾
Encoder – Compax3					G B K 2 3 / ⁽¹⁾
for LXR linear motors		(cable chain compatible)			G B K 3 3 / ⁽¹⁾
for BLMA linear motors		(cable chain compatible)			G B K 3 2 / ⁽¹⁾

Order code for interface cables and plugs

PC – Compax3 (RS232)					S S K 0 1 / ⁽¹⁾
on X11 (Ref /Analog)	with flying leads				S S K 2 1 / ⁽¹⁾
on X12 (I/Os digital)	with flying leads				S S K 2 2 / ⁽¹⁾
on X11 (Ref /Analog)	for I/O terminal block				S S K 2 3 / ⁽¹⁾
on X12 (I/Os digital)	for I/O terminal block				S S K 2 4 / ⁽¹⁾
PC ⇔ POP (RS232)					S S K 2 5 / ⁽¹⁾
Compax3 ⇔ POP (RS485)					S S K 2 7 / .. / ... ⁽⁶⁾
Compax3 HEDA ⇔ Compax3 HEDA or PC ⇔ C3powerPLmC					S S K 2 8 / .. / ... ⁽⁵⁾
Compax3 X11 ⇔ Compax3 X11 (Encoder coupling of 2 axes)					S S K 2 9 / ⁽¹⁾
HEDA bus termination plug (for the first and last Compax3 in the HEDA - Bus)					B U S 0 7 / 0 1
Profibus cable ²	non prefabricated				S S L 0 1 / ⁽¹⁾
Profibus plug					B U S 0 8 / 0 1
CAN-Bus cable ²	non prefabricated				S S L 0 2 / ⁽¹⁾
CANbus connector					B U S 1 0 / 0 1

Order Code connection set for Compax3

for C3S0xxV2	ZBH 02/01				Z B H 0 2 / 0 1
for C3S0xxV4 / S150V4 / S1xxV2	ZBH 02/02				Z B H 0 2 / 0 2
for C3S300V4	ZBH 02/03				Z B H 0 2 / 0 3

Order Code operating module

Operating module					B D M 0 1 / 0 1

Order Code terminal block

for I/Os without luminous indicator	for X11, X12				E A M 0 6 / 0 1
for I/Os with luminous indicator	for X12				E A M 0 6 / 0 2

Parker EME

Compax3 Accessories

Order Code braking resistors

for C3S063V2 or C3S075V4	0.18 / 2.3kW	B	R	M	0	5	/	0	1
for C3S025V2 or C3S038V4	60 / 250W	B	R	M	0	8	/	0	1
for C3S150V4	0.57 / 6.9kW	B	R	M	0	6	/	0	2
for C3S150V2 and C3S300V4	4/01:0.57 / 6.9kW 4/02:0.74 / 8.9kW	B	R	M	0	4	/	0	...
for C3S300V4	4/03:1.5 / 18kW								
for C3S100V2	0.45 / 6.9kW	B	R	M	0	9	/	0	1

Order Code mains filter

for C3S025V2 or S063V2		N	F	I	0	1	/	0	1
for C3S0xxV4, S150V4 or S1xxV2		N	F	I	0	1	/	0	2
for C3S300V4		N	F	I	0	1	/	0	3

Order Code motor output filter

up to 6,3 A rated motor current		M	D	R	0	1	/	0	4
Up to 16 A rated motor current		M	D	R	0	1	/	0	1
up to 30 A rated motor current		M	D	R	0	1	/	0	5

Order Code decentralized input terminals

PIO 2DI 24V DC 3.0ms	2-channel digital input terminal	P	I	O	4	0	0		
PIO 4DI 24V DC 3.0ms	4-channel digital input terminal	P	I	O	4	0	2		
PIO 8DI 24V DC 3.0ms	8-channel digital input terminal	P	I	O	4	3	0		
PIO 2AI DC ± 10V differential input	2 channel analog input terminal (± 10V differential input)	P	I	O	4	5	6		
PIO 4AI 0 - 10V DC S.E.	4 channel analog input terminal (0-10V signal voltage)	P	I	O	4	6	8		
PIO 2AI 0 - 20mA differential input	2 channel analog input terminal (0 - 20mA differential input)	P	I	O	4	8	0		

Order Code decentralized output terminals

PIO 2DO 24V DC 0.5A	2 channel digital output terminal (output voltage 0.5A)	P	I	O	5	0	1		
PIO 4DO 24V DC 0.5A	4 channel digital output terminal (output voltage 0.5A)	P	I	O	5	0	4		
PIO 8DO 24V DC 0.5A	8 channel digital output terminal (output voltage 0.5A)	P	I	O	5	3	0		
PIO 2AO 0 - 10V DC	2 channel analog output terminal (0-10V signal voltage)	P	I	O	5	5	0		
PIO 2AO 0 - 20mA	2 channel analog output terminal (0-20mA signal voltage)	P	I	O	5	5	2		
PIO 2AO DC ± 10V	2 channel analog output terminal (± 10V Signalspannung)	P	I	O	5	5	6		

Order Code CANopen Fieldbus Coupler

CANopen Standard	max. vectorial sum current for bus terminals 1650mA at 5V	P	I	O	3	3	7		
CANopen ECO	max. vectorial sum current for bus terminals 650mA at 5V	P	I	O	3	4	7		

⁽¹⁾ Length code 1

Length [m]	1,0	2,5	5,0	7,5	10,0	12,5	15,0	20,0	25,0	30,0	35,0	40,0	45,0	50,0
Order code	01	02	03	04	05	06	07	08	09	10	11	12	13	14

Example: SSK01/09: length 25m

⁽²⁾ Colors according to DESINA

⁽³⁾ With motor connector

⁽⁴⁾ With cable eye for motor terminal box

⁽⁵⁾ Length code 2 for SSK28

Length [m]	0,25	0,5	1,0	3,0	5,0	10,0
Order code	20	21	01	22	03	05

Order code: SSK27/nn/..

Length A (Pop - 1. Compax3) variable (the last two numbers according to the length code for cable, for example SSK27/nn/01)

Length B (1. Compax3 - 2. Compax3 - ... - n. Compax3) fixed 50 cm (only if there is more than 1 Compax3, i.e. nn greater than 01)

Number n (the last two digits)

Examples: SSK27/05/.. for connecting from Pop to 5 Compax3.

SSK27/01/.. for connection from Pop to one Compax3

MOK55 and MOK54 can also be used for linear motors LXR406, LXR412 and BLMA.

8.3 Parker servo motors

In this chapter you can read about:

Direct drives	191
Rotary servo motors.....	193

8.3.1. Direct drives

In this chapter you can read about:

Transmitter systems for direct drives	191
Linear motors	192
Torque motors.....	192

8.3.1.1 Transmitter systems for direct drives

The Feedback option F12 makes it possible to operate linear motors as well as torque motors. Compax3 supports the following transmitter systems:

Special encoder systems for direct drives	Option F12
Analog hall sensors	<ul style="list-style-type: none"> ◆ Sine - cosine signal (max. $5V_{SS}^3$; typical 1Vss) 90° offset ◆ U-V Signal (max. $5V_{SS}^4$; typical 1Vss) 120° offset.
Encoder (linear or rotatory)	<ul style="list-style-type: none"> ◆ Sine-cosine (max. $5V_{SS}^5$; typical 1Vss) (max. 400kHz) or ◆ TTL (RS422) (max. 5MHz) <p>with the following modes of commutation:</p> <ul style="list-style-type: none"> ◆ Automatic commutation (see on page 192) or ◆ Digital hall sensors
Distance coded feedback systems	<ul style="list-style-type: none"> ◆ Distance coding with 1VSS - Interface ◆ Distance coding with RS422 - Interface (Encoder)
Feedback error compensation	<ul style="list-style-type: none"> ◆ Feedback error compensation (offset & amplification) for analog hall sensors and sine-cosine encoder can be activated via MotorManager.

³ Max. differential input between SIN- (X13/7) and SIN+ (X13/8).

⁴ Max. differential input between SIN- (X13/7) and SIN+ (X13/8).

⁵ Max. differential input between SIN- (X13/7) and SIN+ (X13/8).

The motor performs automatic commutation after:

- ◆ Power on,
- ◆ A configuration download or
- ◆ An IEC program download

The time duration (typically 5-10 sec) of automatic commutation can be optimized with the start current (see in the optimization display of the C3 ServoManager; given as a percentage of the reference current). Note that values that are too high will cause Error 0x73A6 to be triggered.

Typically the motor moves by 4% of the pitch length or, with rotary direct drives 4% of 360°/number of pole pairs - maximum 50%.

Note the following conditions for automatic commutation

- ◆ The linear motor must not be at the end limits for automatic commutation.
- ◆ Actively working load torques are not permitted during automatic commutation.
- ◆ Rubbing caused by friction deteriorates the effect of automatic commutation.
- ◆ With the exception of missing commutation information, the controller/motor combination is configured and ready for operation (parameters correctly assigned for the linear motor/drive). The feedback and the direction of the field of rotation in effect must match.
- ◆ The auto-commutating function must be adapted to fit the mechanics if necessary during commissioning.

8.3.1.2 Linear motors

Parker offers you a number of systems of linear motor drives:

Linear motors	Feed force (continuous/dynamic)	Stroke length:
LMDT ironless linear servo motors:	26 ... 1,463N	almost any
LMI iron-cored linear servo motors:	52 ... 6,000N	64 ... 999mm
Linear motors of the LXR series:	315N / 1,000N	up to 3m
Linear motor module BLMA:	605N / 1,720N	up to 6m

8.3.1.3 Torque motors

Parker offers you an extensive range of torque motors that can be adapted to your application. Please contact us for information.

Additional information can be found in the **Internet** <http://www.parker-eme.com> in the direct drives section.

8.3.2. Rotary servo motors

Parker offers you an extensive range of servo motors that can be adapted to your application. Please contact us for information.

For additional information please refer to the **Internet**
(http://www.parker.com/euro_emd/EME/Literature_List/dokumentationen/SMH_MH_Cat%20engl.pdf)

or on the CD supplied in the documentations file:

Catalogue = SMH_MH_Kat engl.pdf

User guide = SMH_MH-Manual engl.pdf

8.4 Connections to the motor

In this chapter you can read about:

Resolver cable	195
SinCos cable	196
Overview of motor cables	196
Motor cable with plug	197
Motor cable for terminal box	198

Under the designation "REK.." (resolver cables) and "MOK.." (motor cables) we can deliver motor connecting cables in various lengths to order. If you wish to make up your own cables, please consult the cable plans shown below:

Order code for motor cables ²

			<input type="text"/>	<input type="text"/>	<input type="text"/>	<input type="text"/>	<input type="text"/>	<input type="text"/>	<input type="text"/>
for SMH / MH56 / MH70 / MH105 ³	(1.5mm ² ; to 13.8A)		M	O	K	5	5	/	...
for SMH / MH56 / MH70 / MH105 ³	(1.5mm ² ; to 13.8A)	(cable chain compatible)	M	O	K	5	4	/	...
for SMH / MH56 / MH70 / MH105 ³	(2.5mm ² ; to 18.9A)		M	O	K	5	6	/	...
for SMH / MH56 / MH70 / MH105 ³	(2.5mm ² ; to 18.9A)	(cable chain compatible)	M	O	K	5	7	/	...
for MH145 / MH205 ⁴	(1.5mm ² ; to 13.8A)		M	O	K	6	0	/	...
for MH145 / MH205 ⁴	(1.5mm ² ; to 13.8A)	(cable chain compatible)	M	O	K	6	3	/	...
for MH145 / MH205 ⁴	(2.5mm ² ; to 18.9A)		M	O	K	5	9	/	...
for MH145 / MH205 ⁴	(2.5mm ² ; to 18.9A)	(cable chain compatible)	M	O	K	6	4	/	...
for MH145 / MH205 ⁴	(6mm ² ; up to 32.3A)	(cable chain compatible)	M	O	K	6	1	/	...
for MH145 / MH205 ⁴	(10mm ² ; up to 47.3A)	(cable chain compatible)	M	O	K	6	2	/	...

Order code for feedback cables

			<input type="text"/>	<input type="text"/>	<input type="text"/>	<input type="text"/>	<input type="text"/>	<input type="text"/>	<input type="text"/>
for Resolver ²			R	E	K	4	2	/	...
for Resolver ²		(cable chain compatible)	R	E	K	4	1	/	...
for SinCos® – Feedback devices ²		(cable chain compatible)	G	B	K	2	4	/	...
Encoder – Compax3			G	B	K	2	3	/	...
for LXR linear motors		(cable chain compatible)	G	B	K	3	3	/	...
for BLMA linear motors		(cable chain compatible)	G	B	K	3	2	/	...

8.4.1. Resolver cable

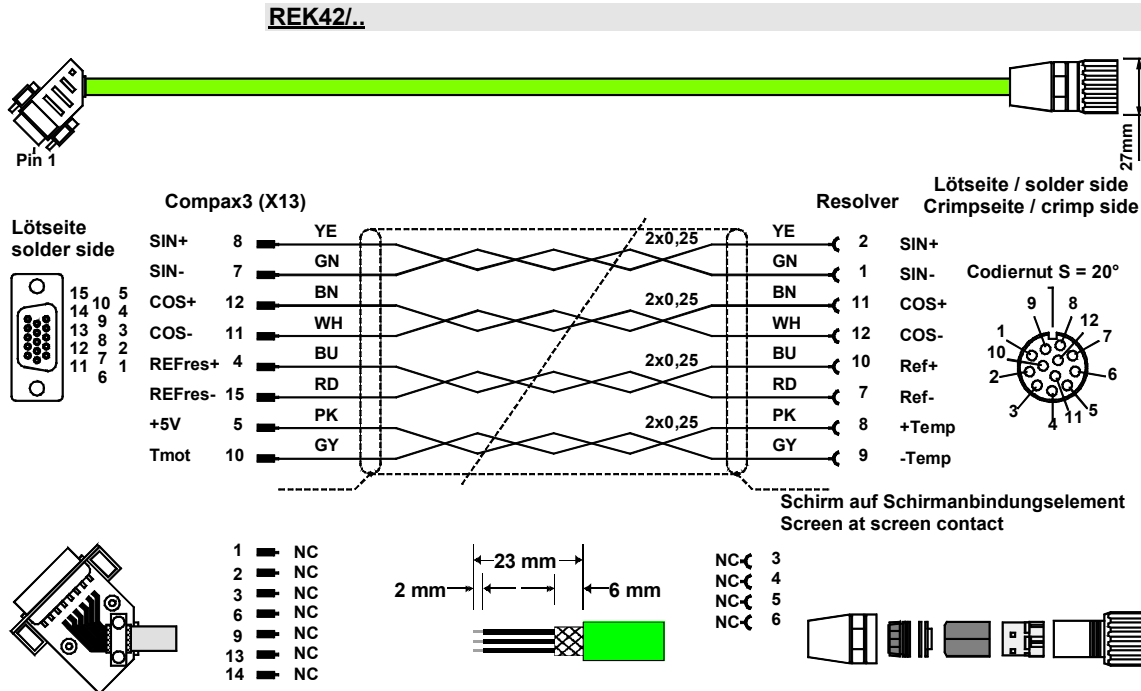

The same cable (with changed conductor coloring) is available under the designation REK41/.. in a version which is suitable for cable chain systems.

You will find the length code in the **accessories order code** (see on page 188)

8.4.2. SinCos cable

GBK24/...: Cable chain compatible

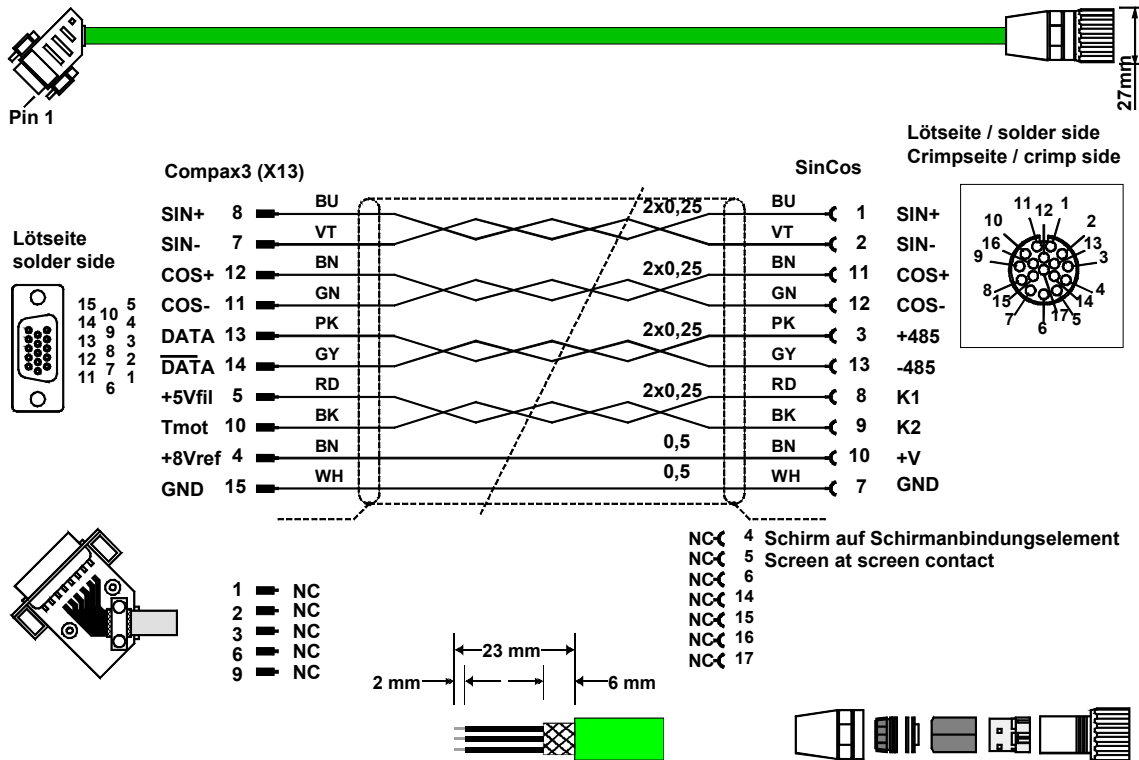

You will find the length code in the **accessories order code** (see on page 188)

8.4.3. Overview of motor cables

Cross-section / max. permanent load	Motor connector SMH motors MH56, MH70, MH105		Motor terminal box MH145, MH205	
	standard	cable chain compatible	standard	cable chain compatible
1.5 mm ² / up to 13.8 A	MOK55	MOK54	MOK60	MOK63
2.5 mm ² / up to 18.9 A	MOK56	MOK57	MOK59	MOK64
6 mm ² / up to 32.3 A	-	-	-	MOK61
10 mm ² / up to 47.3 A	-	--	-	MOK62

8.4.4. Motor cable with plug

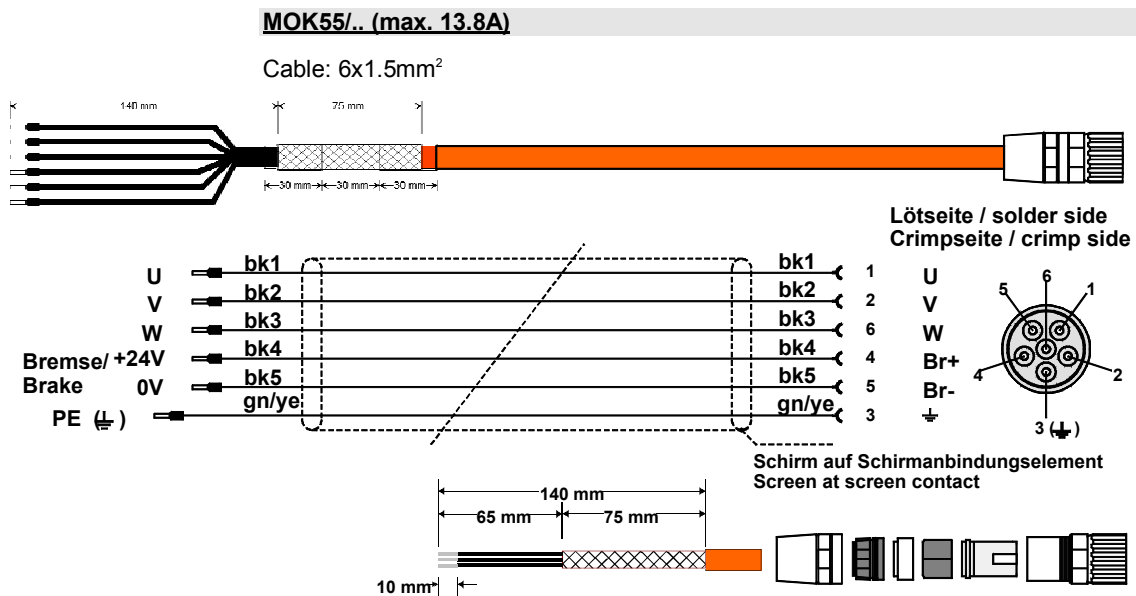

MOK54/... (max. 13.8A) cable chain compatible

Same structure (conductor coloring may be changed) as MOK55/.. available in cable chain compatible version.

MOK56/... (max. 18.9A)

Same structure (conductor coloring/designations may be changed) as MOK55, but with 6x2,5mm²

MOK57/... (max. 18.9A) cable chain compatible

Same structure (conductor coloring/designations may be changed) as MOK55, but with 4x2,5 + 2x1mm² and cable chain compatible.

You will find the length code in the **accessories order code** (see on page 188)

8.4.5. Motor cable for terminal box

MOK61/.. (max. 32.3 A) cable chain compatible

Cable: 4x6mm² + 2x1mm²

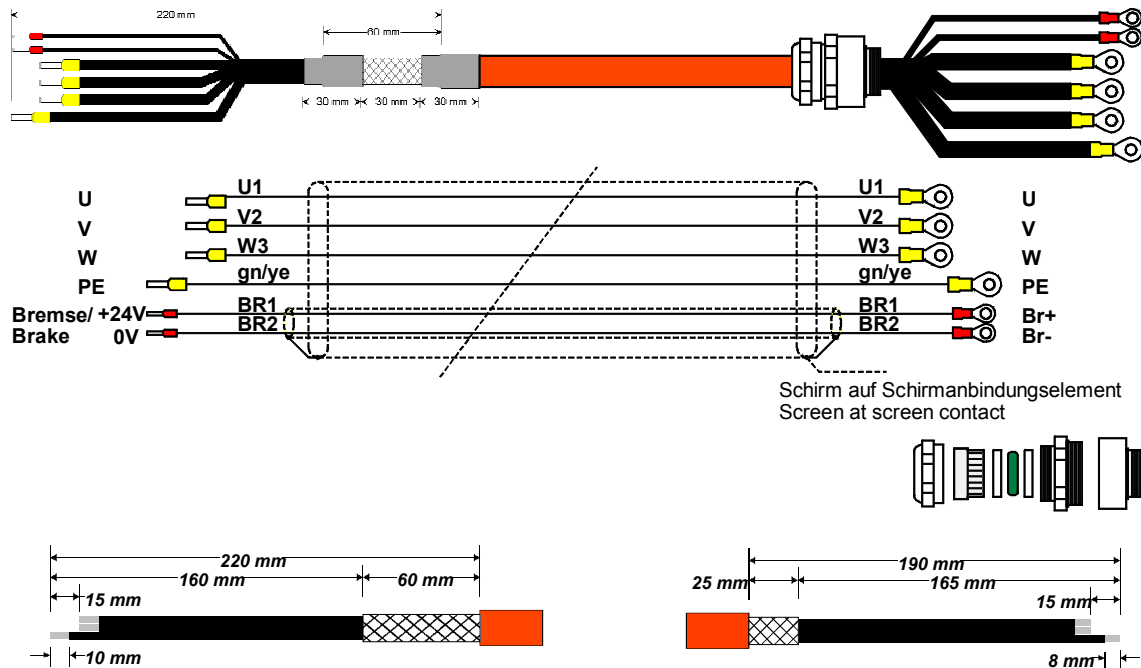

MOK62/.. (max. 47.3 A) cable chain compatible

Same structure (conductor coloring/designations may be changed) as MOK61/.. but with 4x10mm² + 2x1mm².

MOK60/.. (max. 13.8A) standard

MOK63/.. (max. 13.8 A) cable chain compatible

Same structure (conductor coloring/designations may be changed) as MOK61/.. but with 6x1,5mm².

MOK59/.. (max. 18.9A) standard

MOK64/.. (max. 18.9 A) cable chain compatible

Same structure (conductor coloring/designations may be changed) as MOK61/.. but with 6x2,5mm².

You will find the length code in the **accessories order code** (see on page 188)

8.5 EMC measures

In this chapter you can read about:

Mains filter	199
Motor output filter	201

8.5.1. Mains filter

For radio disturbance suppression and for complying with the emission limit values for **CE compliant operation** (see on page 13) we offer mains filters:

Observe the maximum permitted length of the connection between the mains filter and the device:

- ◆ unshielded <0.5m;
- ◆ shielded < 5m (fully shielded on ground – e.g. ground of control cabinet)

Order Code mains filter

	<input type="text"/>	<input type="text"/>	<input type="text"/>	/	<input type="text"/>	<input type="text"/>
for C3S025V2 or S063V2	N	F	I	0	1	0 1
for C3S0xxV4, S150V4 or S1xxV2	N	F	I	0	1	0 2
for C3S300V4	N	F	I	0	1	0 3

8.5.1.1 Mains filter NFI01/01

for Compax3 S025 V2 and Compax3 S063 V2

Dimensional drawing:

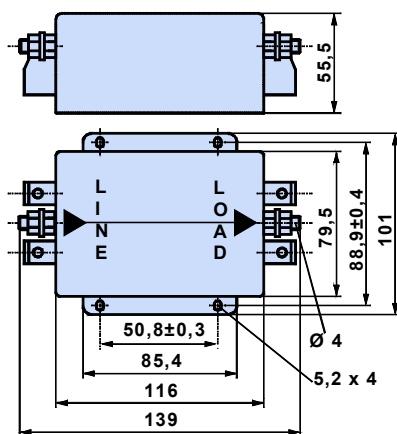

8.5.1.2 Mains filter NFI01/02

for Compax3 S0xx V4, Compax3 S150 V4 and Compax3 S1xx V2

Dimensional drawing:

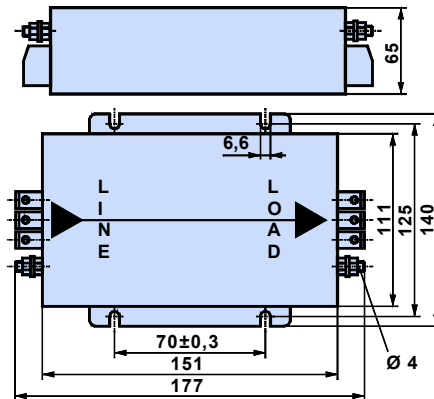

8.5.1.3 Mains filter for NFI01/03

for Compax3 S300

Dimensional drawing:

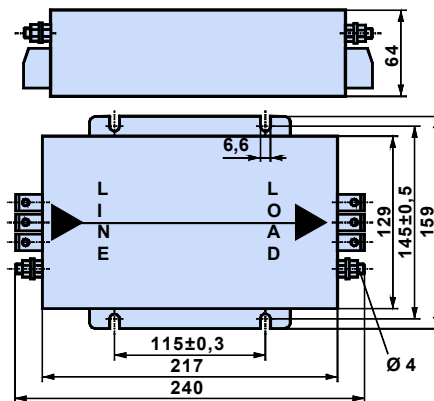

8.5.2. Motor output filter

In this chapter you can read about:

Motor output filter MDR01/04	201
Motor output filter MDR01/01	202
Motor output filter MDR01/05	202
Wiring of the motor output filter	202

We offer motor output filters for disturbance suppression when the motor connecting cables are long (>20m):

Order Code motor output filter

	<table border="1" style="display: inline-table; border-collapse: collapse;"> <tr><td style="width: 20px; height: 20px;"></td><td style="width: 20px; height: 20px;"></td><td style="width: 20px; height: 20px;"></td></tr> </table> <table border="1" style="display: inline-table; border-collapse: collapse; margin: 0 5px;"> <tr><td style="width: 20px; height: 20px;"></td><td style="width: 20px; height: 20px;"></td></tr> </table> / <table border="1" style="display: inline-table; border-collapse: collapse;"> <tr><td style="width: 20px; height: 20px;"></td><td style="width: 20px; height: 20px;"></td></tr> </table>							
up to 6,3 A rated motor current	M D R 0 1 / 0 4							
Up to 16 A rated motor current	M D R 0 1 / 0 1							
up to 30 A rated motor current	M D R 0 1 / 0 5							

8.5.2.1 Motor output filter MDR01/04

up to 6,3 A rated motor current

Dimensional drawing:

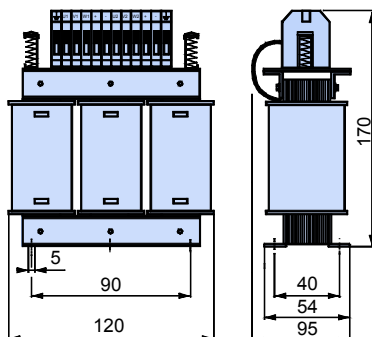

8.5.2.2 Motor output filter MDR01/01

Up to 16 A rated motor current

Dimensional drawing:

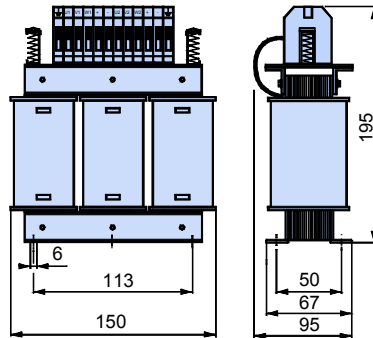

8.5.2.3 Motor output filter MDR01/05

up to 30 A rated motor current

Dimensional drawing: On request

8.5.2.4 Wiring of the motor output filter

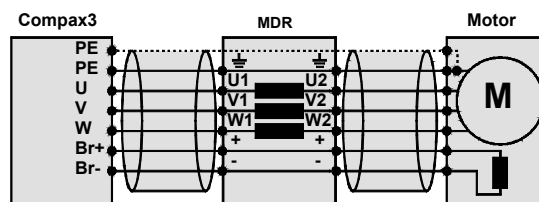

8.6 External ballast resistors

In this chapter you can read about:

BRM8/01 braking resistors	204
BRM9/01 braking resistor	204
BRM5/01 braking resistor	204
Braking resistor BRM6/02	205
Braking resistor BRM4/0x	205

Danger! 	Hazards when handling ballast resistors! Housing temperature up to 200°C! Dangerous voltage! The device may be operated only in the mounted state! The external ballast resistors must be installed such that contact with the human body is prevented. Install the connecting leads at the bottom. Observe the instructions on the resistors (warning plate).
---	--

**The ballast resistors are equipped with a 1.5m connecting lead.
Please note that the length must not exceed 2m**

Ballast resistors for Compax3

Braking Resistor	Drive	sustained	dynamic
BRM8/01 (100Ω)	Compax3 S025 V2 Compax3 S015 V4 Compax3 S038 V4	60W	250W (<1s; ≥10s cooling time)
BRM5/01 (56Ω)	Compax3 S063 V2 Compax3 S075 V4	180W	2300W (<0.4s; ≥8s cooling time)
BRM6/02 (33Ω)	Compax3 S150 V4	570W	6900 W (<1s; ≥ 20s cooling time)
BRM4/01 (15Ω)	Compax3 S300 V4 Compax3 S150 V2	570W	6900 W (<1s; ≥ 20s cooling time)
BRM4/02 (15Ω)	Compax3 S300 V4 Compax3 S150 V2	740W	8900W (<1s; ≥20s cooling time)
BRM4/03 (15Ω)	Compax3 S300 V4	1500W	18kW (<1s; ≥20s cooling time)
BRM9/01 (22Ω)	Compax3 S100 V2	450W	6900 W (<1s; ≥ 20s cooling time)

8.6.1. BRM8/01braking resistors

Dimensional drawing:

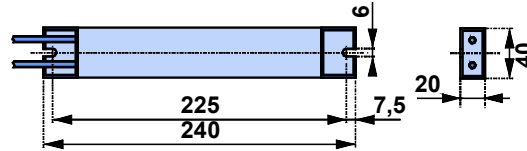

8.6.2. BRM9/01 braking resistor

Dimensional drawing:

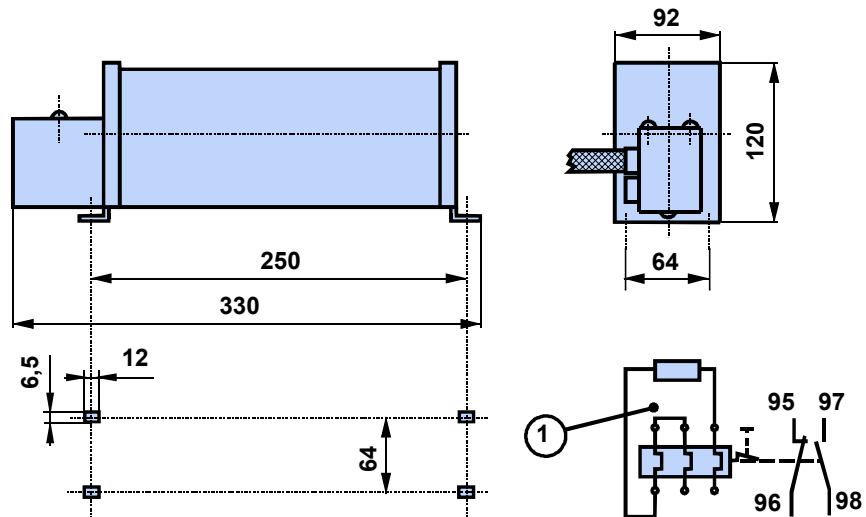

8.6.3. BRM5/01 braking resistor

Dimensional drawing:

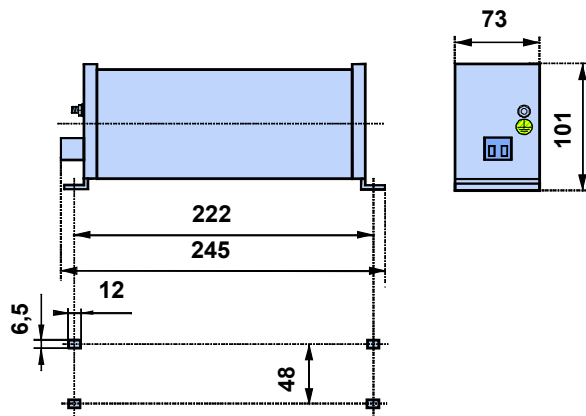

8.6.4. Braking resistor BRM6/02

Dimensional drawing:

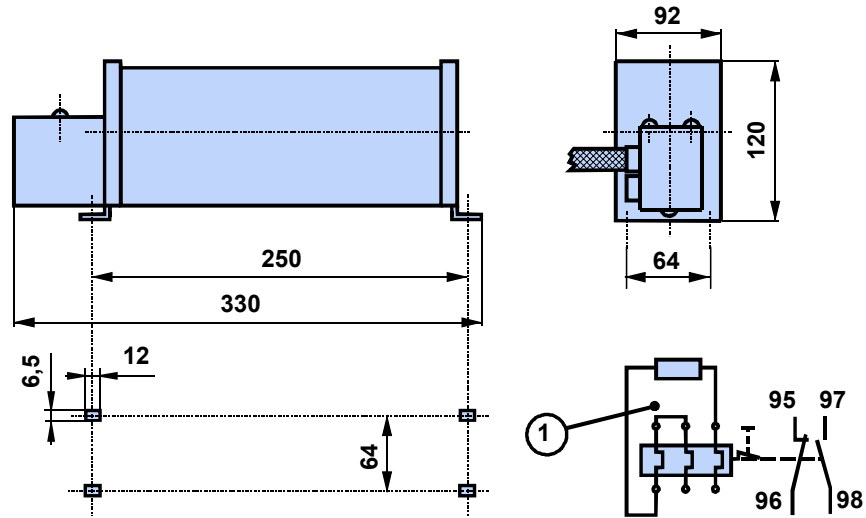

1: thermal current overload cut-off

8.6.5. Braking resistor BRM4/0x

Dimensional drawing:

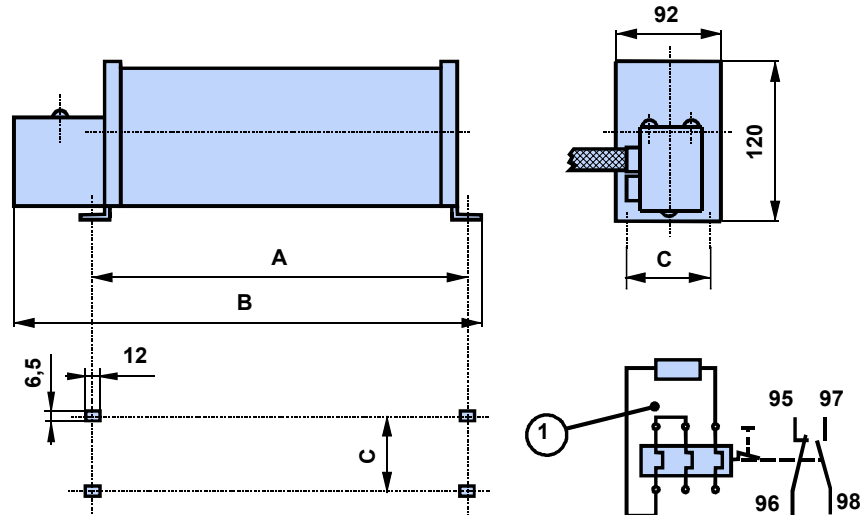

1: thermal current overload cut-off

Dimensions:

Size:	BRM4/01	BRM4/02	BRM4/03
A	250	300	540
B	330	380	620
C	64	64	64

8.7 Operator control module BDM

Order Code operating module

Operating module

					/		
B	D	M	0	1	/	0	1

Flexible service and maintenance



Functions:

- ◆ Mobile or stationary handling: can remain on the unit for display and diagnostic purposes, or can be plugged into any unit.
- ◆ Can be plugged in while in operation
- ◆ Power supply via Compax3 servo control
- ◆ Display with 2 times 16 places.
- ◆ Menu-driven operation using 4 keys.
- ◆ Displays and changing of values.
- ◆ Display of Compax3 messages.
- ◆ Duplication of device properties and IEC61131-3 program to another Compax3 with identical hardware.
- ◆ Additional information can be found in the BDM manual. This can be found on the Compax3 CD or on our Homepage: **BDM manual** (http://www.parker.com/euro_emd/EME/Literature_List/dokumentationen/BDM%20eng.pdf).



8.8 EAM06: Terminal block for inputs and outputs

Order Code terminal block

for I/Os without luminous indicator	for X11, X12
for I/Os with luminous indicator	for X12

					/		
E	A	M	0	6	/	0	1
E	A	M	0	6	/	0	2

The terminal block EAM06/.. can be used to route the Compax3 plug connector X11 or X12 for further wiring to a terminal strip and to a Sub-D plug connector.

Via a supporting rail (Design:  or ) the terminal block can be installed on a mounting rail in the control cabinet.

EAM06/ is available in 2 variants:

- ◆ EAM06/01: Terminal block for X11, X12 without luminous indicator
- ◆ EAM06/02: Terminal block for X12 with luminous indicator

Corresponding connecting cables EAM06 - Compax3 are available:

- ◆ from X11 - EAM06/01: SSK23/..
- ◆ from X12 - EAM06/xx: SSK24/..

EAM06/01: Terminal block without luminous indicator for X11 or X12

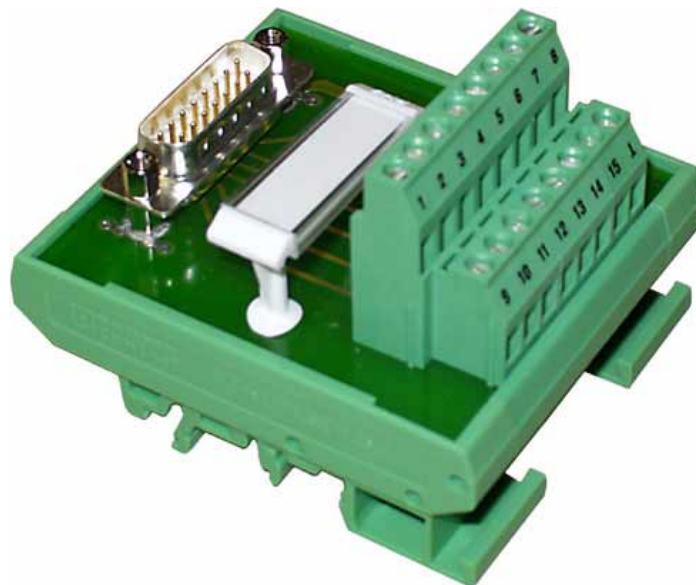

Width: 67.5mm

EAM6/02: Terminal block with luminous indicator for X12

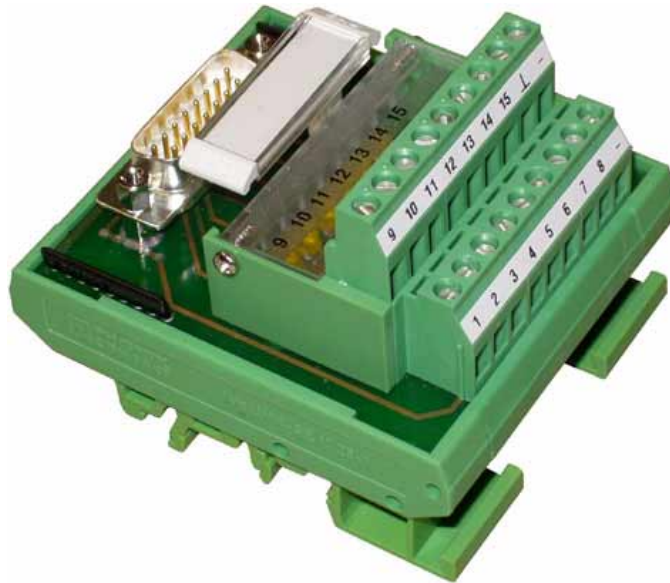

Width: 67.5mm

Cable plan SSK23/...: X11 to EAM 06/01

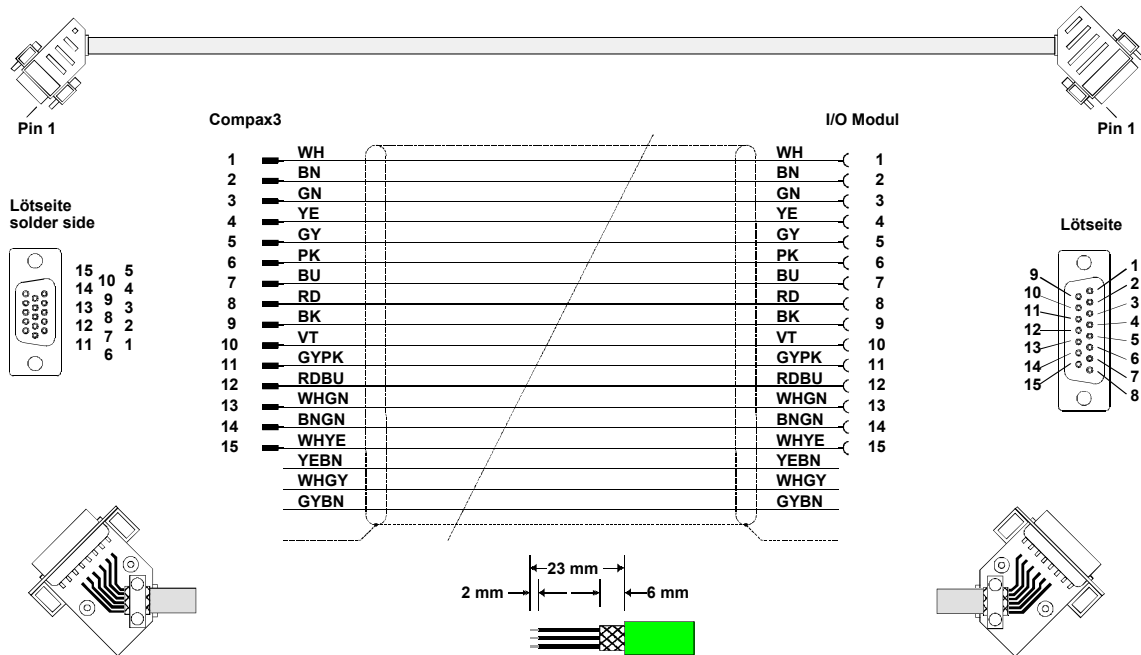

Cable plan SSK24/...: X12 to EAM 06/xx

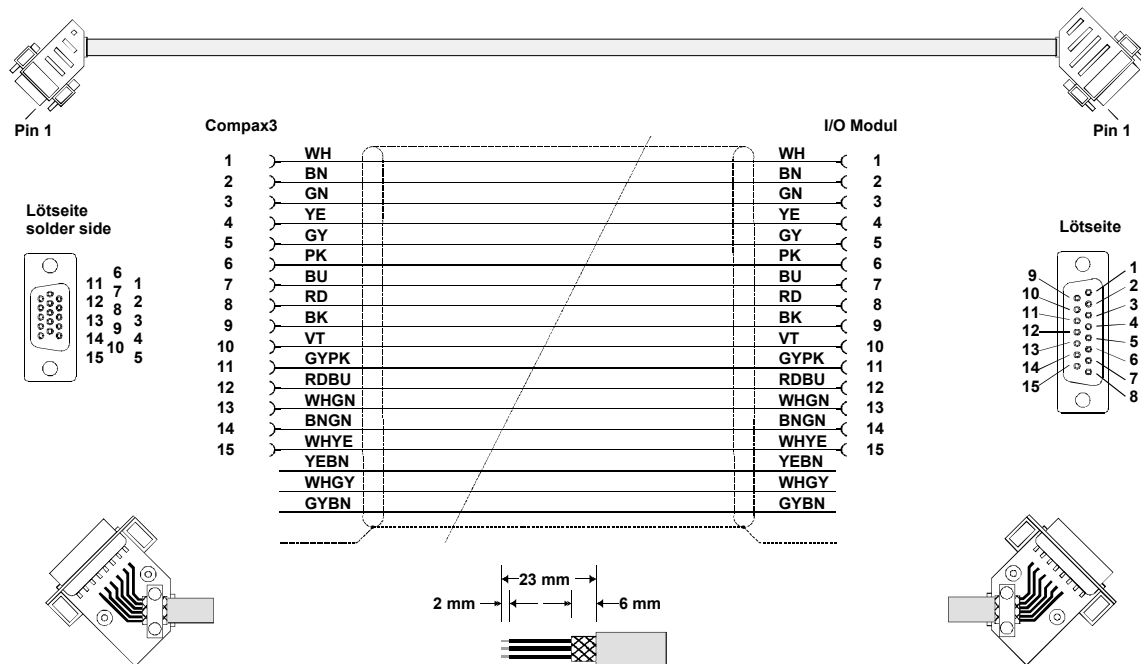

8.9 ZBH plug set

The plug set which is available as accessory comprises:

- ◆ a shield terminal with large contact area for the motor cable shield, and
- ◆ the mating plug connectors for the Compax3 plug connectors X1, X2, X3, and X4

Order Code connection set for Compax3

for C3S0xxV2	ZBH 02/01	Z	B	H	0	2	/ 0 1
for C3S0xxV4 / S150V4 / S1xxV2	ZBH 02/02	Z	B	H	0	2	/ 0 2
for C3S300V4	ZBH 02/03	Z	B	H	0	2	/ 0 3

ZBH02/01: for Compax3 S0xx 1AC V2



ZBH02/02: for Compax3 S0xx 3AC V4, Compax3 S150 3AC V4 and Compax3 S1xx 3AC V2



ZBH02/03: for Compax3 S300 3AC V4



8.10 Interface cable

In this chapter you can read about:

RS232 cable.....	211
RS485 cable to Pop.....	212
I/O interface X12.....	213
Ref X11.....	214
Encoder coupling of 2 Compax3 axes.....	215
Encoder cable.....	216

Order code for interface cables and plugs

PC – Compax3 (RS232)								
on X11 (Ref /Analog)	with flying leads	S	S	K	0	1	/	...
on X12 (I/Os digital)	with flying leads	S	S	K	2	1	/	...
on X11 (Ref /Analog)	for I/O terminal block	S	S	K	2	2	/	...
on X12 (I/Os digital)	for I/O terminal block	S	S	K	2	3	/	...
PC ⇔ POP (RS232)		S	S	K	2	4	/	...
Compax3 ⇔ POP (RS485)		S	S	K	2	5	/	...
Compax3 HEDA ⇔ Compax3 HEDA or PC ⇔ C3powerPLmC		S	S	K	2	7	/	..
Compax3 X11 ⇔ Compax3 X11 (Encoder coupling of 2 axes)		S	S	K	2	8	/	..
HEDA bus termination plug (for the first and last Compax3 in the HEDA - Bus)		S	S	K	2	9	/	...
Profibus cable ⁽²⁾	non prefabricated	B	U	S	0	7	/	0 1
Profibus plug		B	U	S	0	8	/	0 1
CAN-Bus cable ⁽²⁾	non prefabricated	S	S	L	0	2	/	...
CANbus connector		B	U	S	1	0	/	0 1

8.10.1. RS232 cable

SSK1/..

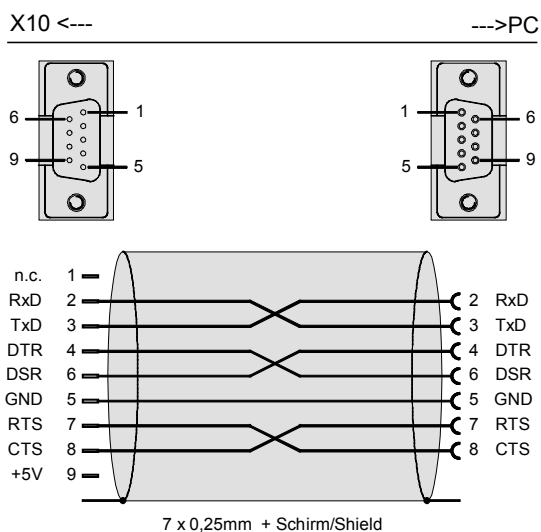

You will find the length code in the **accessories order code** (see on page 188)

8.10.2. RS485 cable to Pop

SSK27: Connection Pop - Compax3 - Compax3 - ...

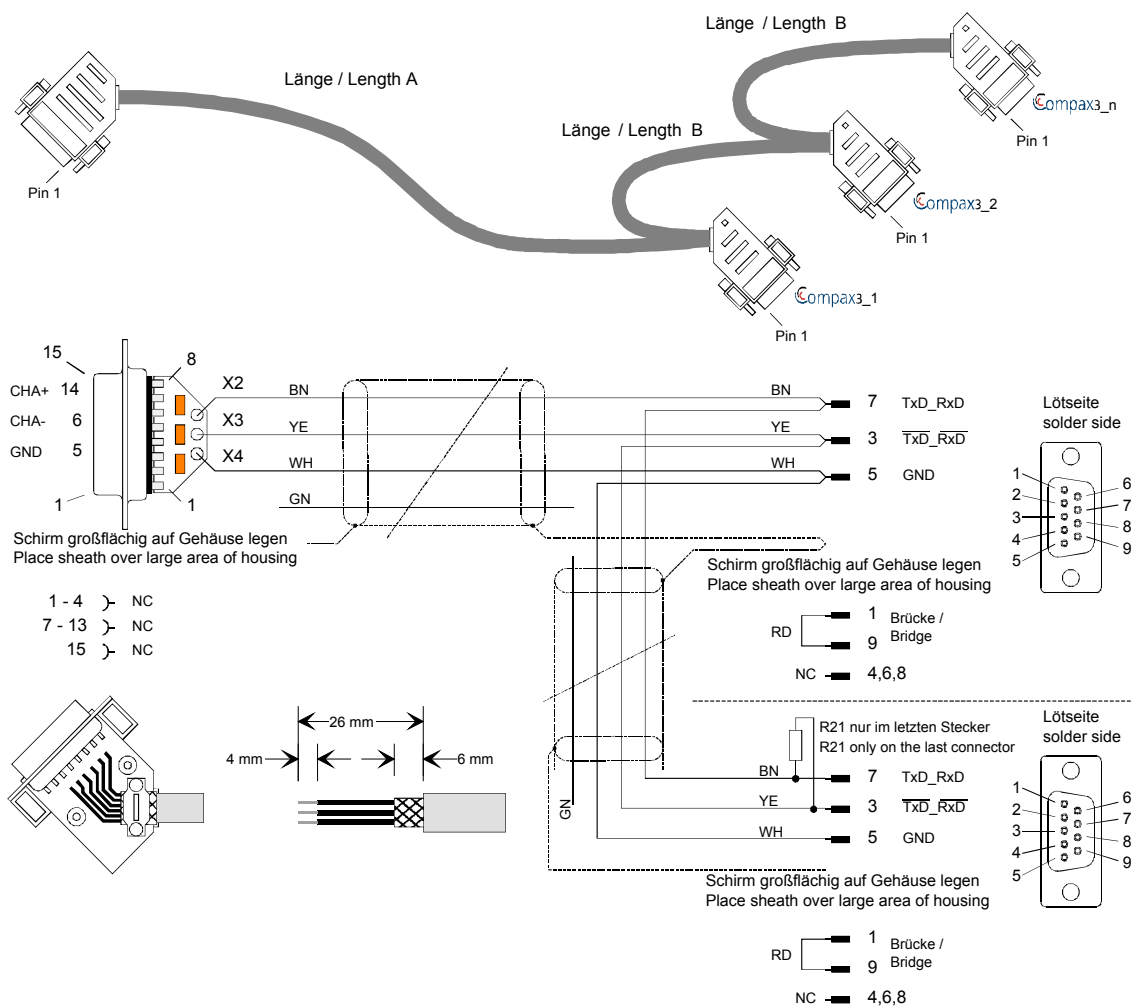

Order code: SSK27/nn/..

Length A (Pop - 1. Compax3) variable (the last two numbers according to the length code for cable, for example SSK27/nn/01)

Length B (1. Compax3 - 2. Compax3 - ... - n. Compax3) fixed 50 cm (only if there is more than 1 Compax3, i.e. nn greater than 01)

Number n (the last two digits)

Examples: SSK27/05/.. for connecting from Pop to 5 Compax3.

SSK27/01/.. for connection from Pop to one Compax3

8.10.3. I/O interface X12

SSK22/...: Cable for X12 with open ends

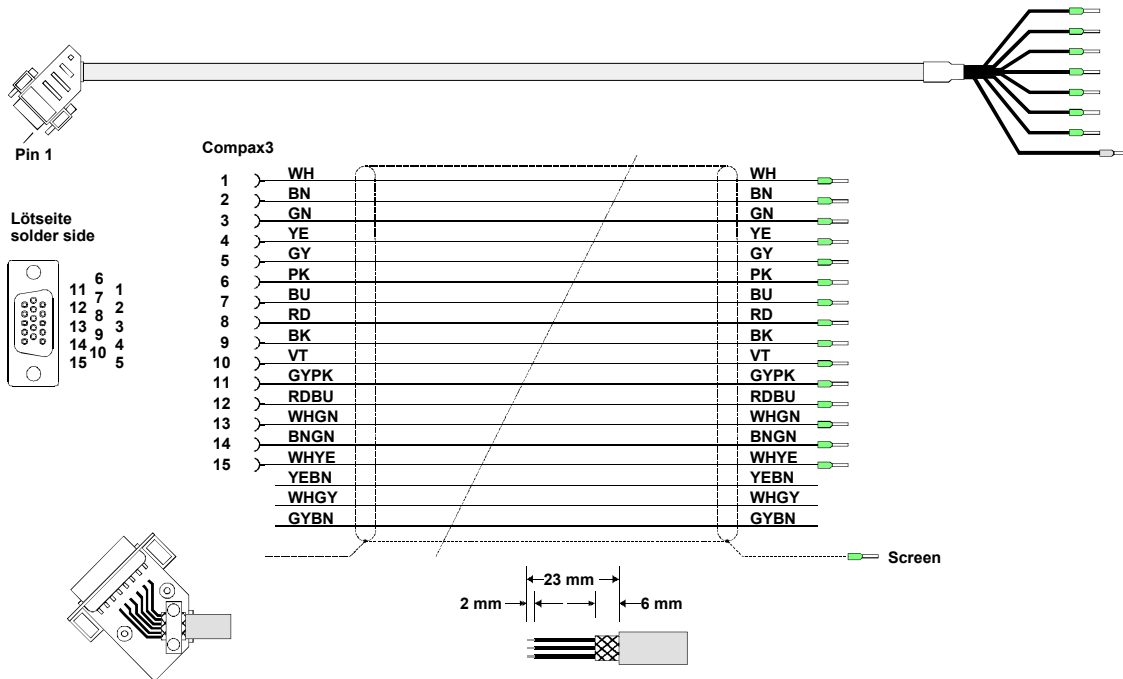

You will find the length code in the **accessories order code** (see on page 188)

8.10.4. Ref X11

SSK21/...: Cable for X11 with open ends

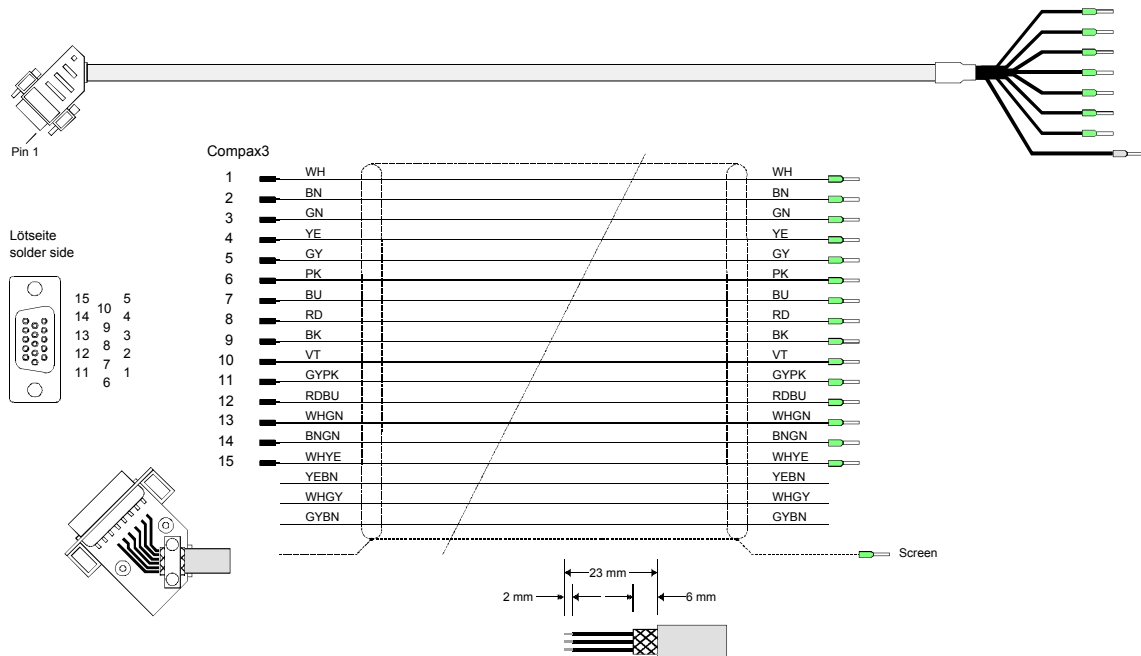

You will find the length code in the **accessories order code** (see on page 188)

8.10.5. Encoder coupling of 2 Compax3 axes

SSK29/...: Cable from Compax3 X11 to Compax3 X11

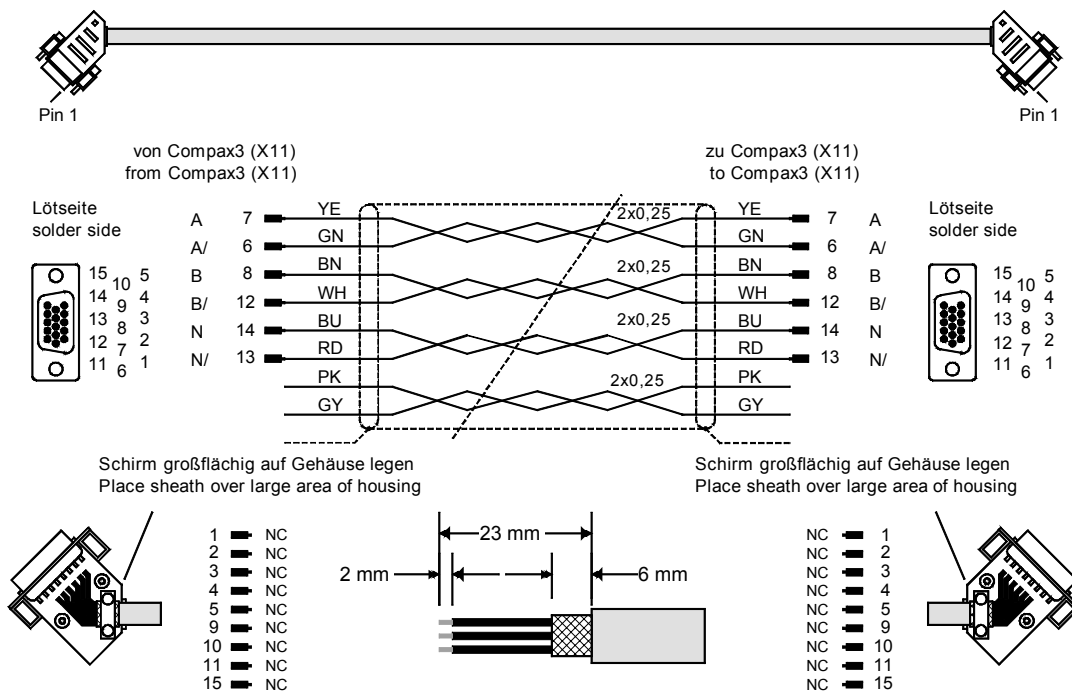

You will find the length code in the **accessories order code** (see on page 188)

8.10.6. Encoder cable

GBK23/... Connection Encoder - Compax3

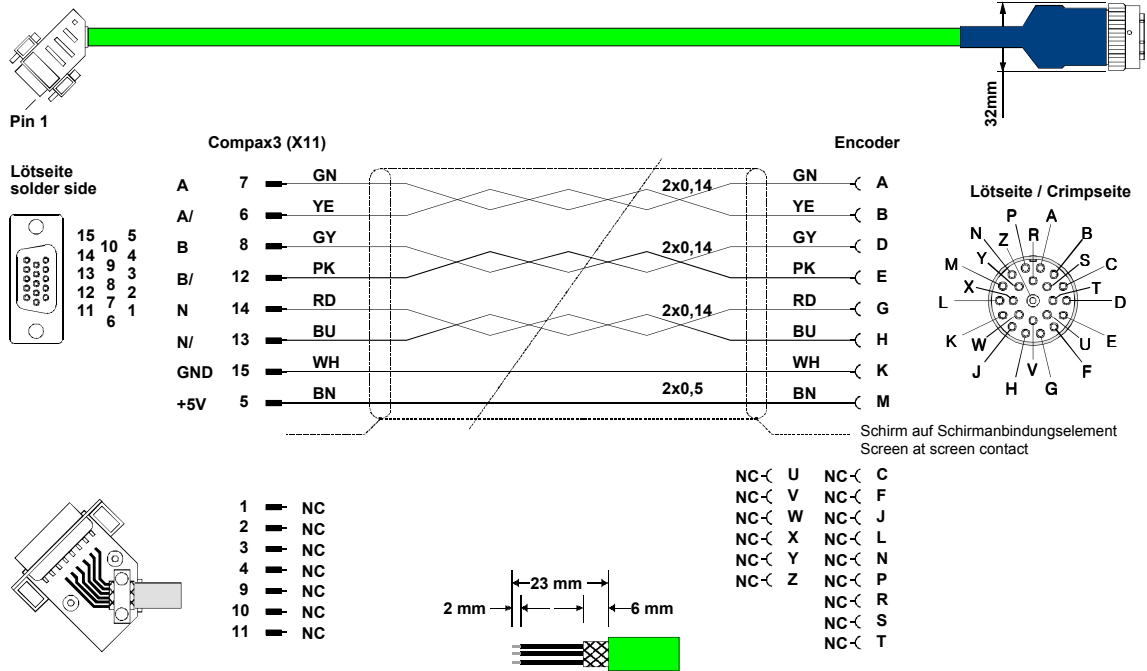

You will find the length code in the **accessories order code** (see on page 188)

8.11 Input/output option M12

An optional input/output extension is available for Compax3. This option is named M12 and offers 12 digital 24V inputs/outputs (Ports) on X22.

The use of the option as inputs or outputs is programmable in groups of 4 (with the object "Activate input/Output option M10 / M12").

The outputs are written via the object 133.3 "Output word for the I/O option"; this applies only for the ports defined as output.

The inputs are read via the object 121.2 "Input word for the I/O option"; all ports are being read, also the outputs.

8.11.1. Assignment of the X22 connector



PIN X22/	Input/output	I/O /X22 High density/Sub D
1	n.c.	reserved
2	O0/I0	Output 0 / Input 0 - adjustable
3	O1/I1	Output 1 / Input 1 - adjustable
4	O2/I2	Output 2 / Input 2 - adjustable
5	O3/I3	Output 3 / Input 3 - adjustable
6	O4/I4	Output 4 / Input 4 - adjustable
7	O5/I5	Output 5 / Input 5 - adjustable
8	O6/I6	Output 6 / Input 6 - adjustable
9	O7/I7	Output 7 / Input 7 - adjustable
10	O8/I8	Output 8 / Input 8 - adjustable
11	I	24 VDC power supply
12	O9/I9	Output 9 / Input 9 - adjustable
13	O10/I10	Output 10 / Input 10 - adjustable
14	O11/I11	Output 11 / Input 11 - adjustable
15	I	Gnd 24 V

All inputs and outputs have 24V level.

Maximum load on an output: 100mA

Maximum capacitive load: 50nF (max. 4 Compax3 inputs)

Caution! The 24VDC power supply (X22/11) must be supplied from an external source and must be protected by a 1.2A delayed fuse!

8.11.1.1 Input wiring of digital inputs

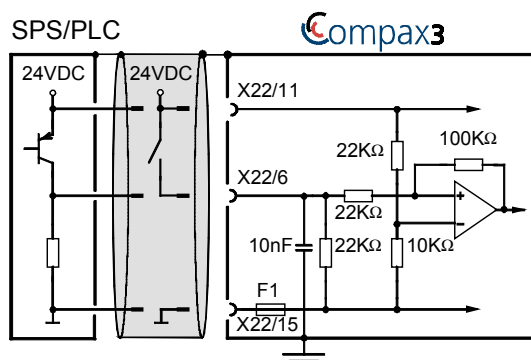

The circuit example is valid for all digital inputs!

F1: quick action electronic fuse; can be reset by switching the 24VDC supply off and on again.

8.11.1.2 Output wiring of digital outputs

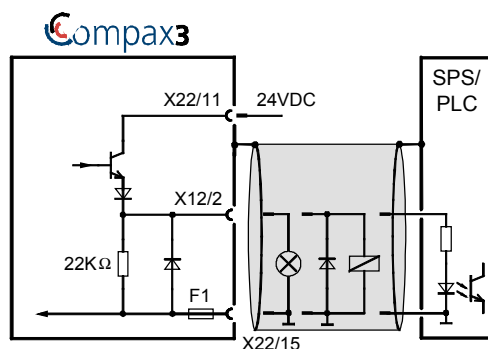

The circuit example is valid for all digital outputs!

The outputs are short circuit proof; a short circuit generates an error.

F1: quick action electronic fuse; can be reset by switching the 24VDC supply off and on again.

8.12 HEDA (motion bus) - Option M11



	RJ45 (X20)	RJ45 (X21)
PIN	HEDA in	HEDA out
1	Rx	Tx
2	Rx/	Tx/
3	Lx	Lx
4	-	reserved
5	-	reserved
6	Lx/	Lx/
7	-	reserved
8	-	reserved

HEDA wiring based on the example of 4 Compax3



Design of the HEDA cable SSK28:

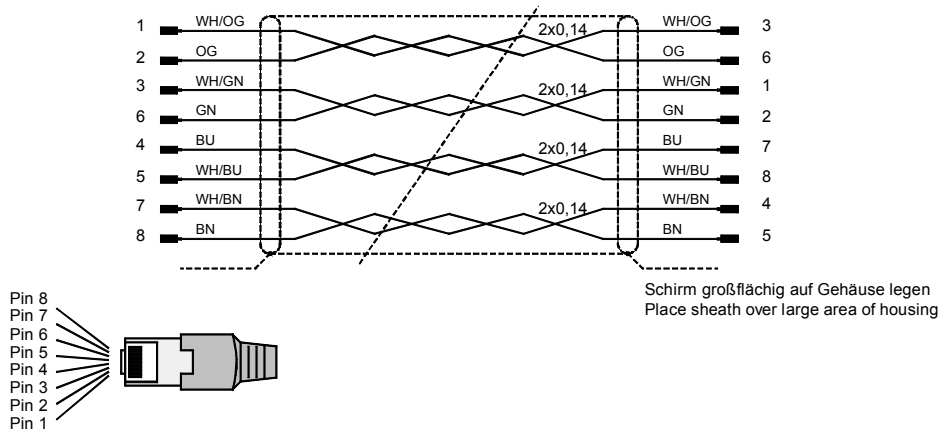

Design of the HEDA bus terminator BUS 07/01:

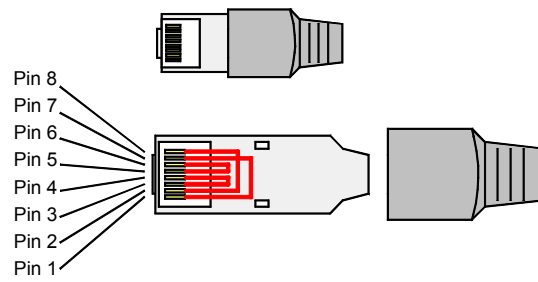

Jumpers: 1-7, 2-8, 3-4, 5-6

8.13 HEDA (M11) & I/Os (M12) => Option M10

The M10 option includes the M12 input/output option and the HEDA M11 option.

9. Technical data

Mains connection for Compax3 S0xx 1AC V2

Controller type	S025 V2	S063 V2
Mains voltage	Single phase 230VAC/240VAC 80-253 VAC/50-60Hz	
Input current	6Aeff	13Aeff
Maximum fuse rating per device	10 A (automatic circuit breaker K)	16 A (automatic circuit breaker K)

Mains connection Compax3 S1xx 3AC V2

Controller type	S100 V2	S150 V2
Mains voltage	Three phase 3* 230VAC/240VAC 80-253 VAC/50-60Hz	
Input current	10Aeff	13Aeff
Maximum fuse rating per device	16 A (automatic circuit breaker K)	20 A (automatic circuit breaker K)

Mains connection Compax3 Sxxx 3AC V4

Controller type	S015 V4	S038 V4	S075 V4	S150 V4	S300 V4
Mains voltage	Three phase 3*400VAC/480VAC 80-528VAC / 50-60Hz				
Input current	3Aeff	6Aeff	10Aeff	16Aeff	22Aeff
Maximum fuse rating per device	6A	10A	16A	20A	25A
	Automatic circuit breaker K				D*

*for CE-conform operation: Automatic circuit breaker K S273-K.

Control voltage 24VDC (X4/1, X4/2)

Controller type	Compax3
Voltage range	21 - 27VDC
Current drain of the device	0.8A
Total current drain	0.8 A + Total load of the digital outputs + current for the motor holding brake
Ripple	0.5Vpp
Requirement according to safe extra low voltage (SELV)	yes

Output data Compax3 S0xx at 1*230VAC/240VAC

Controller type	S025 V2	S063 V2
Output voltage	3x 0-240V	3x 0-240V
Nominal output current	2.5Aeff	6.3Aeff
Pulse current for 5s	5.5Aeff	12.6Aeff
Power	1kVA	2.5kVA
Switching frequency	16kHz	16kHz
Power loss for In	30W	60W
Efficiency	95%	96%

Output data Compax3 S1xx at 3*230VAC/240VAC

Controller type	S100 V2	S150 V2
Output voltage	3x 0-240V	3x 0-240V
Nominal output current	10Aeff	15Aeff
Pulse current for 5s	20Aeff	30Aeff
Power	1kVA	2.5kVA
Switching frequency	16kHz	8kHz
Power loss for In	80 W	130W
Efficiency	95%	96%

Output data Compax3 Sxxx at 3*400VAC

Controller type	S015 V4	S038 V4	S075 V4	S150 V4	S300 V4
Output voltage	3x 0-400V				
Nominal output current	1.5Aeff	3.8Aeff	7.5 Aeff	15Aeff	30Aeff
Pulse current for 5s	4.5Aeff	9.0Aeff	15Aeff	30Aeff	60Aeff
Power	1kVA	2.5kVA	5kVA	10kVA	20kVA
Switching frequency	16kHz	16kHz	16kHz	8kHz	8kHz
Power loss for In	60W	80 W	120W	160W	350W
Efficiency	92%	95%	96%	97%	97%

Output data Compax3 Sxxx at 3*480VAC

Controller type	S015 V4	S038 V4	S075 V4	S150 V4	S300 V4
Output voltage	3x 0-480V				
Nominal output current	1.5Aeff	3.8Aeff	6.5Aeff	13.9Aeff	30Aeff
Pulse current for 5s	4.5Aeff	7.5 Aeff	15Aeff	30Aeff	60Aeff
Power	1.25kVA	3.1kVA	6.2kVA	11.5kVA	25kVA
Switching frequency	16kHz	16kHz	16kHz	8kHz	8kHz
Power loss for In	60W	80 W	120W	160W	350W
Efficiency	93%	96%	97%	98%	98%

Resulting nominal and peak currents depending on the switching frequency

Compax3 S0xx V2 at 1*230VAC/240VAC

Switching frequency*		S025 V2	S063 V2
16kHz	I_{nominal}	2.5A _{eff}	6.3A _{eff}
	$I_{\text{peak}} (<5\text{s})$	5.5A _{eff}	12.6A _{eff}
32kHz	I_{nominal}	2.5A _{eff}	5.5A _{eff}
	$I_{\text{peak}} (<5\text{s})$	5.5A _{eff}	12.6A _{eff}

Compax3 S1xx V2 at 3*230VAC/240VAC

Switching frequency*		S100 V2	S150 V2
8kHz	I_{nominal}	-	15A _{eff}
	$I_{\text{peak}} (<5\text{s})$	-	30A _{eff}
16kHz	I_{nominal}	10A _{eff}	12.5A _{eff}
	$I_{\text{peak}} (<5\text{s})$	20A _{eff}	25A _{eff}
32kHz	I_{nominal}	8A _{eff}	10A _{eff}
	$I_{\text{peak}} (<5\text{s})$	16A _{eff}	20A _{eff}

Compax3 S0xx V4 at 3*400VAC

Switching frequency*		S015 V4	S038 V4	S075 V4	S150 V4	S300 V4
8kHz	I_{nominal}	-	-	-	15A _{eff}	30A _{eff}
	$I_{\text{peak}} (<5\text{s})$	-	-	-	30A _{eff}	60A _{eff}
16kHz	I_{nominal}	1.5A _{eff}	3.8A _{eff}	7.5A _{eff}	10.0A _{eff}	26A _{eff}
	$I_{\text{peak}} (<5\text{s})$	4.5A _{eff}	9.0A _{eff}	15.0A _{eff}	20.0A _{eff}	52A _{eff}
32kHz	I_{nominal}	1.5A _{eff}	2.5A _{eff}	3.7A _{eff}	5.0A _{eff}	14A _{eff}
	$I_{\text{peak}} (<5\text{s})$	3.0A _{eff}	5.0A _{eff}	10.0A _{eff}	10.0A _{eff}	28A _{eff}

Compax3 S0xx V4 at 3*480VAC

Switching frequency*		S015 V4	S038 V4	S075 V4	S150 V4	S300 V4
8kHz	I_{nominal}	-	-	-	13.9A _{eff}	30A _{eff}
	$I_{\text{peak}} (<5\text{s})$	-	-	-	30A _{eff}	60A _{eff}
16kHz	I_{nominal}	1.5A _{eff}	3.8A _{eff}	6.5A _{eff}	8.0A _{eff}	21.5A _{eff}
	$I_{\text{peak}} (<5\text{s})$	4.5A _{eff}	7.5A _{eff}	15.0A _{eff}	16.0A _{eff}	43A _{eff}
32kHz	I_{nominal}	1.0A _{eff}	2.0A _{eff}	2.7A _{eff}	3.5A _{eff}	10A _{eff}
	$I_{\text{peak}} (<5\text{s})$	2.0A _{eff}	4.0A _{eff}	8.0A _{eff}	7.0A _{eff}	20A _{eff}

The values marked with grey are the pre-set values (standard values)!

*corresponds to the frequency of the motor current

Accuracy at the motor

For option F10: Resolver	<ul style="list-style-type: none"> ◆ Position resolution: 16Bit (= 0.005°) ◆ Absolute accuracy: ±0,167°
For option F11: SinCos	<ul style="list-style-type: none"> ◆ Position resolution: 19Bit (= 0.0002°) ◆ Absolute accuracy: ±0,005°
For option F12: Direct drives	<ul style="list-style-type: none"> ◆ Maximum position resolution <ul style="list-style-type: none"> ◆ Linear motor: 24 Bits per motor magnet spacing ◆ Rotatory motor: 24 bits per motor revolution ◆ Resolution for analog hall sensors with 1Vss signal 13.5 bits / motor magnet spacing ◆ For 1Vss sine-cosine encoders: 13.5 bits / graduation of the scale of the encoder ◆ For RS 422 encoders: 4x encoder resolution ◆ Accuracy: The exactitude of the position signal is above all determined by the exactitude of the feedback system used.

Motors and feedback systems supported

<p>Motors Direct drives ♦ Linear motors ♦ Torque motors</p>	<ul style="list-style-type: none"> ♦ Sinusoidal commutated synchronous motors <ul style="list-style-type: none"> ♦ Maximum rotating field frequency: 1,000Hz ♦ Max. velocity at 8 pole motors: 15000min⁻¹. ♦ General max. speed: 60*1000/number of pole pairs in ♦ Sinusoidal commutated asynchronous motors <ul style="list-style-type: none"> ♦ Maximum rotating field frequency: 1,000Hz ♦ General max. speed: 60*1000/number of pole pairs - slip in [min⁻¹]. ♦ Field suppression: typically up to triple (higher on request). ♦ Temperature sensor: KTY84-130 ♦ 3 phase synchronous direct drives
<p>Position encoder (Feedback)</p>	<p><u>Option F10: Resolver</u></p>
<p>Litton:</p>	<ul style="list-style-type: none"> ♦ JSSBH-15-E-5 ♦ JSSBH-21-P4 ♦ RE-21-1-A05 ♦ RE-15-1-B04
<p>Tamagawa:</p>	<ul style="list-style-type: none"> ♦ 2018N321 E64
<p>Siemens:</p>	<ul style="list-style-type: none"> ♦ 23401-T2509-C202
	<p><u>Option F11: SinCos®</u></p>
	<ul style="list-style-type: none"> ♦ Singleturn (Stegmann) ♦ Multiturn (Stegmann) Absolute position up to 4096 motor revolutions. ♦ Feedback error compensation (offset & amplification) can be activated via MotorManager.

Special encoder systems for direct drives	Option F12
Analog hall sensors	<ul style="list-style-type: none"> ◆ Sine - cosine signal (max. 5Vss⁶; typical 1Vss) 90° offset ◆ U-V Signal (max. 5Vss⁷; typical 1Vss) 120° offset. ◆
Encoder (linear or rotatory)	<ul style="list-style-type: none"> ◆ Sine-cosine (max. 5Vss⁸; typical 1Vss) (max. 400kHz) or ◆ TTL (RS422) (max. 5MHz) with the following modes of commutation: <ul style="list-style-type: none"> ◆ Automatic commutation (see on page 192) or ◆ Digital hall sensors
Distance coded feedback systems	<ul style="list-style-type: none"> ◆ Distance coding with 1VSS - Interface ◆ Distance coding with RS422 - Interface (Encoder)
Feedback error compensation	<ul style="list-style-type: none"> ◆ Feedback error compensation (offset & amplification) for analog hall sensors and sine-cosine encoder can be activated via MotorManager.

Motor holding brake output

Controller type	Compax3
Voltage range	21 – 27VDC
Maximum output current (short circuit proof)	1.6A

Braking operation Compax3 S0xx 1AC V2

Controller type	S025 V2	S063 V2
Capacitance / storable energy	560µF / 15Ws	1120µF / 30Ws
Minimum ballast - resistance	100Ω	56Ω
Recommended nominal power rating	20 ... 60W	60 ... 180W
Pulse power rating for 1s	1kW	2.5kW

Braking operation Compax3 S1xx 3AC V2

Controller type	S100 V2	S150 V2
Capacitance / storable energy	780µF / 21Ws	1170µF / 31Ws
Minimum ballast - resistance	22Ω	15Ω
Recommended nominal power rating	60 ... 450W	60 ... 600W
Pulse power rating for 1s	4kW	6kW

⁶ Max. differential input between SIN- (X13/7) and SIN+ (X13/8).

⁷ Max. differential input between SIN- (X13/7) and SIN+ (X13/8).

⁸ Max. differential input between SIN- (X13/7) and SIN+ (X13/8).

Brake operation Compax 3 Sxxx 3AC V4

Controller type	S015V4	S038V4	S075V4	S150V4	S300V4
Capacitance / storable energy	235µF / 37Ws	235µF / 37Ws	470µF / 75Ws	690µF / 110Ws	1100µF / 176Ws
Minimum ballast - resistance	100Ω	100Ω	56Ω	22Ω	15Ω
Recommended nominal power rating	60 ... 100W	60 ... 250W	60 ... 500 W	60 ... 1000 W	60 ... 1000 W
Pulse power rating for 1s	1kW	2.5kW	5kW	10 kW	42kW

Ballast resistors for Compax3

Braking Resistor	Drive	sustained	dynamic
BRM8/01 (100Ω)	Compax3 S025 V2 Compax3 S015 V4 Compax3 S038 V4	60W	250W (<1s; ≥10s cooling time)
BRM5/01 (56Ω)	Compax3 S063 V2 Compax3 S075 V4	180W	2300W (<0.4s; ≥8s cooling time)
BRM6/02 (33Ω)	Compax3 S150 V4	570W	6900 W (<1s; ≥ 20s cooling time)
BRM4/01 (15Ω)	Compax3 S300 V4 Compax3 S150 V2	570W	6900 W (<1s; ≥ 20s cooling time)
BRM4/02 (15Ω)	Compax3 S300 V4 Compax3 S150 V2	740W	8900W (<1s; ≥20s cooling time)
BRM4/03 (15Ω)	Compax3 S300 V4	1500W	18kW (<1s; ≥20s cooling time)
BRM9/01 (22Ω)	Compax3 S100 V2	450W	6900 W (<1s; ≥ 20s cooling time)

Mechanical data

Controller type	Dimensions HxWxD [mm]	Weight [kg]
Compax3 S025 V2	199 x 84 x 172	2.0
Compax3 S063 V2	199 x 100 x 172	2.5
Compax3 S015 V4	260 x 84 x 172	3.1
Compax3 S100 V2	260 x 115 x 172	4.3
Compax3 S150 V2	260 x 160 x 172	6.8
Compax3 S038 V4	260 x 100 x 172	3.5
Compax3 S075 V4	260 x 115 x 172	4.3
Compax3 S150 V4	260 x 160 x 172	6.8
Compax3 S300 V4	380 x 175 x 172	10.9

Protection type IP20

Safety technology

Safe standstill certified as per EN954-1, category 3: (BG-PRÜFZERT certification no.: 0403005)	<ul style="list-style-type: none"> ◆ For implementation of the “protection against unexpected start-up” function described in EN1037. ◆ Please note the circuit examples (see on page 38).
--	---

UL certification

conform to UL:	◆ according to UL508C
Certified	◆ E-File_No.: E235 342

The UL certification is documented by a "UL" logo on the device (type specification plate).

"UL" logo



Insulation requirements

Protection class	Protection class I according to EN 50 178 (VDE 0160 part 1)
Protection against human contact with dangerous voltages	According to DIN VDE 0106, part 100
Overvoltage category	Voltage class III according to HD 625 (VDE 0110-1)
Degree of contamination	Degree of contamination 2 according to HD 625 (VDE 0110 part 1) and EN 50 178 (VDE 0160 part 1)

Ambient conditions

General ambient conditions	In accordance with EN 60 721-3-1 to 3-3 Climate (temperature/humidity/barometric pressure): Class 3K3	
Permissible ambient temperature:		
Operation	0 to +45 C	Class 3K3
Storage	-25 to +70 C	Class 2K3
Transport	-25 to +70 C	Class 2K3
Tolerated humidity:	No condensation	
Operation	<= 85% Class 3K3	(Relative humidity)
Storage	<= 95% Class 2K3	
Transport	<= 95% Class 2K3	
Elevation of operating site	<=1000m above sea level for 100% load ratings Please inquire for greater elevations	
Cooling mode	Compax3 S025 V2 ... S150 V4: Convection Compax3 S300 V4: Forced air ventilation with fan in the heat dissipator	
Sealing	IP20 protection class according to EN 60 529	
EMC interference emission	Limit values according to EN 61 800-3, First environment (Commercial and residential area) Class 'A' with integrated mains filter for up to 10 m cable length, otherwise with external mains filter	
EMC disturbance immunity	Limit values for industrial utilization according to EN 61 800-3 (includes EN 50 081-2 and EN 50 082-2)	

EC directives and harmonised EC norms

<p>EC low voltage directive 73/23/EEC and RL 93/68/EEC</p>	<p>EN 50 178, General industrial safety norm Equipping electric power systems with electronic operating equipment HD 625, general electrical safety Insulation principles for electrical operating equipment EN 60 204-1, Machinery norm, partly applied</p>
<p>EC-EMC directive 89/336/EEC</p>	<p>EN 61 800-3, EMC norm Product standard for variable speed drives EN 50 081-2 ... 50 082-2, EN 61 000-4-2 ...61 000-4-5</p>

RS232 - / RS485 - interface

<p>RS232</p>	<ul style="list-style-type: none"> ◆ 115200 baud ◆ Word length: 8 bits, 1 start bit, 1 stop bit ◆ Hardware handshake XON, XOFF
<p>RS485 (2 or 4-wire)</p>	<ul style="list-style-type: none"> ◆ 9600, 19200, 38400, 57600 or 115200 baud ◆ Word length 7/8 bit, 1 start bit, 1 stop bit ◆ Parity (can be switched off) even/odd ◆ 2 or 4-wire

Signal interfaces

<p>Signal inputs / signal sources</p>	<ul style="list-style-type: none"> ◆ Encoder – input track A/B (RS422) <ul style="list-style-type: none"> ◆ up to max. 10MHz ◆ internal quadrature of the resolution ◆ Step / direction input (24V-level) Max. 300kHz at $\geq 50\Omega$ source impedance and minimum pulse width of 1,6μs. ◆ +/-10V analog input 14Bit; 62.5μs scanning rate.
<p>Signal outputs</p>	<ul style="list-style-type: none"> ◆ Encoder simulation <ul style="list-style-type: none"> ◆ 1...16384 increments/revolution or pitch ◆ Limit frequency 620kHz ◆ Bypass function with encoder feedback with feedback module F12.
<p>Signal transmission</p>	<p>HEDA (option M10 or M11) Exchange of process values:</p> <ul style="list-style-type: none"> ◆ from Slave to Master ◆ from Slave to Master and ◆ from Slave to Slave.

Functions3

Motion control via I/Os (Option M10 or M12 required) or via RS232 / RS485	<ul style="list-style-type: none"> ◆ up to 31 motion sets possible with the following functions. <ul style="list-style-type: none"> ◆ Absolute positioning ◆ Relative positioning ◆ Electronic Gearbox (Gearing) ◆ Reg-related positioning (exactitude < 1µs) ◆ Speed control ◆ Stop - Set ◆ Definition of status bits for sequence control (with M10 or M12) ◆ Specification of speed, acceleration, deceleration and jerk ◆ Different machine zero modes ◆ Absolute / Relative positioning
Actual position	<ul style="list-style-type: none"> ◆ Encoder Output ◆ Resolution: 4 - 16384 Increments / revolution
Signal monitor	<ul style="list-style-type: none"> ◆ 2 channels ±10 V analogue ◆ Resolution: 8 Bit
8 digital inputs (24V level) (standard)	<ul style="list-style-type: none"> ◆ Energize motor/Ackn; Stop; Manual+, Manual-, Reg input, 2 limit switches, machine zero initiator,
8 additional digital inputs (with M10 or M12 option)	<ul style="list-style-type: none"> ◆ Address 0 – 4, Start, 2nd Stop, open brake, ◆ 24V level
4 digital outputs	<ul style="list-style-type: none"> ◆ Error, Position/Speed/Gear reched, power output stage currentless, motor stationary with current with setpoint value 0. ◆ Loading max. 100mA
4 additional digital outputs (with M10 or M12 option)	<ul style="list-style-type: none"> ◆ Ref detected / referenced, status bits Bit 1 - 3

10. Index

+

+/-10V analog speed setpoint value as signal source • 127

A

Absolute / Relative positioning • 99
 Accessories order code • 188
 Acknowledge error (example) • 135
 Adjusting the machine zero proximity switch • 81
 Advanced control parameters • 116
 Analog / Encoder (plug X11) • 32
 ASCII - record • 140
 Assignment of the X22 connector • 217

B

Binary record • 141
 Brake delay times • 123
 Braking Resistor • 26, 61, 226
 Braking resistor / high voltage DC (plug X2) • 26
 Braking resistor / high voltage supply plug X2 for 1AC 230VAC/240VAC devices • 26
 Braking resistor / high voltage supply plug X2 for 3AC 230VAC/240VAC devices • 26
 Braking resistor / high voltage supply plug X2 for 3AC 400VAC/480VAC devices • 27
 Braking resistor BRM4/0x • 205
 Braking resistor BRM6/02 • 205
 BRM5/01 braking resistor • 204
 BRM8/01braking resistors • 204
 BRM9/01 braking resistor • 204

C

C3I12T11 Function overview • 17
 Calibration of the analog input • 121
 Calling up the input simulation • 120
 Cam • 165
 Change initiator logic • 86
 Commissioning mode • 122
 Compax3 - Objects • 145
 Compax3 Accessories • 187
 Compax3 device description • 19
 Conditions of utilization • 13
 Conditions of utilization for CE-conform operation • 13
 Conditions of utilization for UL permission • 15
 Configuration • 56
 Configuration name / comments • 112
 Connection of the digital Outputs/Inputs • 33
 Connection of the power voltage of 2 Compax3 3AC devices • 27
 Connections of the encoder interface • 32
 Connections to the motor • 194

Control Loop Dynamics • 113
 Control via RS232 / RS485 • 128
 Control voltage 24 VDC • 30
 Control voltage 24VDC / enable (plug X4) • 30
 Control word • 95, 97, 133
 Control word (example) • 135
 Current • 164
 Current (Torque) Limit • 89
 Current on the mains PE (leakage current) • 16

D

Debouncing the limit switches • 85
 Debouncing the machine zero input (X12/14) • 70
 Defining jerk / ramps • 87
 Defining the reference system • 62
 Defining the STOP function • 100
 Device assignment • 9
 Digital inputs/outputs (plug X12) • 33
 Direct drives • 191
 Drive • 160
 Dynamic positioning • 111

E

EAM06 terminal block for inputs and outputs • 206
 Electronic gearbox (Gearing) • 109
 EMC measures • 199
 Encoder A/B 5V or step/direction as signal source • 125
 Encoder bypass with Feedback module F12 (for direct drives) • 99
 Encoder cable • 216
 Encoder coupling of 2 Compax3 axes • 215
 Encoder Output • 99
 Energizing the axis (example) • 135
 Error • 170
 Error history • 135
 Error list • 170
 Example: electronic gearbox with position recording via encoder • 126
 Examples: control via RS232 / RS485 • 135
 Exchange assignment direction reversal / limit switches • 86
 External ballast resistors • 203

F

Feedback • 167
 Following error limit • 91
 Forward control measures • 117
 Function of the LEDs on the front panel • 21
 Functionality • 121

G

Gain alignment • 122

Gearing • 169
General Drive • 61
General hazards • 11

H

Hardware end limits • 85
HEDA (M11) & I/Os (M12) => Option M10 • 220
HEDA (motion bus) - Option M11 • 219
Homing modes with home switch (on X12/14) • 70

I

I/O Assignment • 96, 132
I/O assignment for control via the Compax3 inputs/outputs • 93
I/O assignment, control word and status word with control via RS232 / RS485 • 95, 131
I/O interface X12 • 213
I12 T11 object
 Setpoint delay for bus master • 147
 Status auxiliary voltage • 156
 Status of power output stage temperature • 155
 Status of DC bus voltage • 156
 Status of following error • 153
 Status of long-term motor load • 151
 Status of motor temperature • 155
I12 T11 Object
 Current master position for Gearing • 148
 Status acceleration feed forward • 149
 Status actual acceleration filtered • 148
 Status actual current RMS (torque producing) • 149
 Status actual position • 153
 Status actual position without absolute reference • 153
 Status actual speed filtered • 154
 Status actual speed unfiltered • 154
 Status Analog input 0 • 155
 Status Analog input 1 • 156
 Status analog input cosine • 151
 Status analog input sine • 152
 Status control deviation of current control RMS • 149
 Status control deviation of speed • 154
 Status cosine in signal processing • 152
 Status current & jerk feed forward rms • 149
 Status current phase U • 149
 Status current phase V • 150
 Status demand acceleration • 148
 Status demand jerk setpoint generator • 150
 Status disturbance monitored • 151
 Status of current control signal • 150
 Status of device load • 151
 Status of feedback level • 152
 Status setpoint current RMS (torque producing) • 150
 Status setpoint jerk setpoint generator • 154
 Status setpoint position • 153
 Status setpoint position without absolute reference • 153

 Status setpoint speed controller input • 154
 Status sine in signal processing • 152
 Status speed feed forward • 155
I12 T11 object list sorted by object name • 146
I12 T11 Object: Beginning of the ignore zone • 158
I12 T11 Object: Control word CW • 156
I12 T11 Object: Current error (n) • 157
I12 T11 Object: End of the ignore zone • 157
I12 T11 Object: Error (n-1) in the error history • 147
I12 T11 Object: Input word of the I/O Option • 147
I12 T11 Object: Output word of the I/O option • 147
I12 T11 Object: Status actual acceleration unfiltered • 148
I12 T11 Object: Status word 2 • 157
I12 T11 Object: Status word SW • 157
IEC61131-3 • 167
Ignore zone (example) • 101, 135
Input simulation • 120
Input wiring of digital inputs • 218
Input/output option M12 • 217
Inputs • 165
Installation and dimensions Compax3 • 34
Installation and dimensions Compax3 S100 V2 and S0xx V4 • 35
Installation and dimensions Compax3 S150 V2 and S150 V4 • 36
Installation and dimensions of Compax3 S0xx V2 • 34
Installation and dimensions of Compax3 S300 V4 • 37
Interface cable • 211
Introduction • 9

J

Jerk limitation • 87
Jerk value • 87

L

Layout of the set table • 137
Linear motors • 192

M

Machine Zero • 66
Machine zero modes overview • 68
Machine zero modes without home switch • 76
Machine zero only from motor reference • 78
Machine zero run (example) • 135
Machine zero speed and acceleration • 81
Mains filter • 199
Mains filter for NFI01/03 • 200
Mains filter NFI01/01 • 199
Mains filter NFI01/02 • 200
Mains voltage supply (plug X1) • 24
Manual motion (example) • 135
Maximum operating speed • 92
Measure reference • 62
MN-M 1.2: End switch as machine zero • 79

MN-M 11..00.14: Direction reversal switches on the negative side • 75
 MN-M 128/129: Rising of current while moving to block • 76
 MN-M 130, 131: Determine absolute position via distance coding • 78
 MN-M 132, 133: Determine absolute position via distance coding with direction reversal switches • 80
 MN-M 17.18: End switch as machine zero • 77
 MN-M 19,20: MN-Initiator = 1 on the positive side • 70
 MN-M 21.22: MN-Initiator = 1 on the negative side • 71
 MN-M 23...26: Direction reversal switches on the positive side • 72
 MN-M 27..0.30: Direction reversal switches on the negative side • 72
 MN-M 3.4: MN-Initiator = 1 on the positive side • 73
 MN-M 33,34 MN on the motor zero point • 78
 MN-M 35: MN at the current position • 76
 MN-M 5,6: MN-Initiator = 1 on the negative side • 74
 MN-M 7..0.10: Direction reversal switches on the positive side • 75
 Monitoring / Limit Settings • 89
 Motor • 160
 Motor / Motor brake (plug X3) • 28
 Motor cable for terminal box • 198
 Motor cable with plug • 197
 Motor Connection • 28
 Motor holding brake • 28
 Motor output filter • 201
 Motor output filter MDR01/01 • 202
 Motor output filter MDR01/04 • 201
 Motor output filter MDR01/05 • 202
 Motor Selection • 58
 MoveAbs and MoveRel • 104

O

Object overview I12 T11 • 145
 Offset alignment • 121
 Operating mode / I/O assignment • 93
 Operation with MultiTurn emulation • 67
 Operation with SinCos Multiturn • 67
 Operator control module BDM • 206
 Optimization • 113
 Optimize motor reference point and switching frequency of the motor current • 58
 Order code for Compax3 • 187
 Output wiring of digital outputs • 218
 Overview of motor cables • 196

P

Parker servo motors • 191
 Plug and connector assignment Compax3 • 20
 Plug and pin assignment complete • 22
 Plug assignment Compax3S0xx V2 • 24, 26, 28, 29, 30, 31
 Position • 161
 Positioning window - Position reached • 90

Power supply • 24
 Power supply plug X1 for 1 AC
 230VAC/240VAC devices • 24
 Power supply plug X1 for 3AC
 230VAC/240VAC devices • 24
 Power supply plug X1 for 3AC
 400VAC/480VAC devices • 25
 Programmable status bits (PSBs) • 103

R

Ramp upon error / deenergize • 89
 Reaction times • 94
 Ref X11 • 214
 Reg-related positioning (RegSearch, RegMove) • 105
 Reg-related positioning / defining ignore zone • 101
 Resolver • 29
 Resolver / Feedback (connector X13) • 29
 Resolver cable • 195
 Rotary servo motors • 193
 RS232 & RS485 – interface record • 139
 RS232 / RS485 interface (plug X10) • 31
 RS232 cable • 211
 RS232 plug assignment • 31
 RS485 cable to Pop • 212
 RS485 plug assignment • 31
 RS485 setting values • 111, 139

S

Safe standstill • 38
 Safe Standstill application example • 42
 Safety function – safe standstill - • 38
 Safety Instructions • 11
 Safety notes on the Safe Stop feature • 41
 Safety-conscious working • 11
 Sample circuit example of Compax3 devices with fieldbus option • 47
 Sample circuit example of Compax3 devices without fieldbus option • 42
 Sample circuit for C3 powerPLmC multi-axis application • 51
 Select signal source for Gearing • 124
 Selection of the supply voltage used • 57
 Set selection • 103
 Setting up Compax3 • 55
 Signal source HEDA • 125
 SinCos cable • 196
 Software end limits • 82
 Special safety instructions • 12
 Speed specification (Velocity) • 110
 Speeds • 162
 Start edge (example) • 135
 Status diagram • 129
 Status values • 159
 Status word • 95
 status word 1 & 2 • 98, 134
 Stop command (Stop) • 110
 Superimposed motion • 163

T

Technical data • 221

Time frame signal source master • 127
Torque motors • 192
Transmitter systems for direct drives • 191
Travel Limit Settings • 82
Turning the motor holding brake on and off •
123
Type specification plate • 10

U

Usage in accordance with intended purpose •
11

V

Velocity Filter • 115
Velocity loop damping • 115
Velocity loop stiffness • 114
Virtual Master • 166

W

Warranty conditions • 12
Wiring of analog interfaces • 32
Wiring of the motor output filter • 202
With direction reversal switches • 71, 74, 79
With motor reference point • 73, 78
Without direction reversal switches • 70, 73
Without motor reference point • 70, 76
Write into set table • 102
Write set table (example) • 135

X

X1 • 24
X10 • 31
X11 • 32
X13 • 29
X2 • 26
X3 • 28
X4 • 30

Z

ZBH plug set • 210