

aerospace
climate control
electromechanical
filtration
fluid & gas handling
hydraulics
pneumatics
process control
sealing & shielding

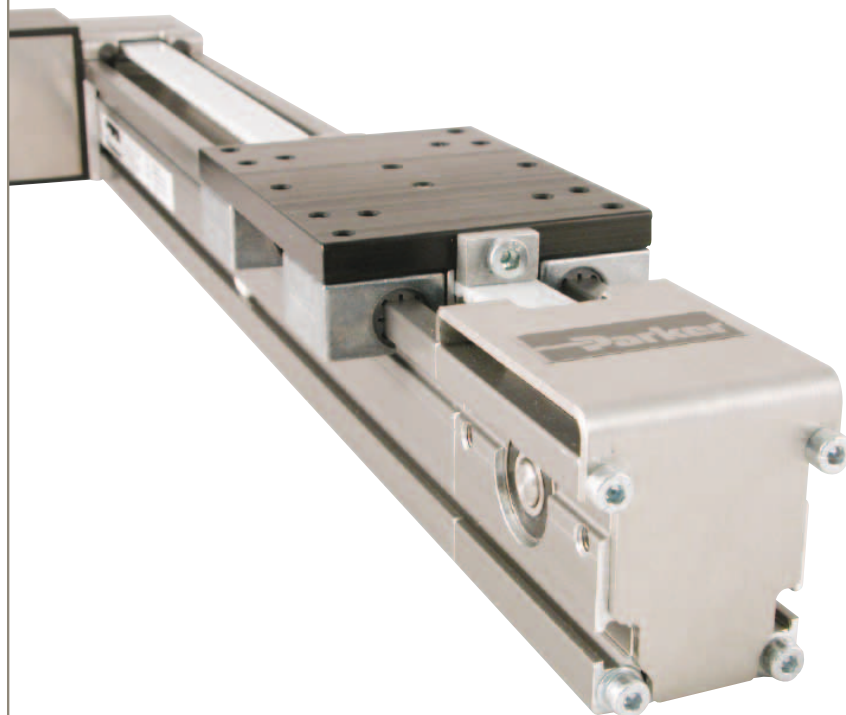

LCB - Compact Linear Actuator

Toothed belt actuator with sliding bearing

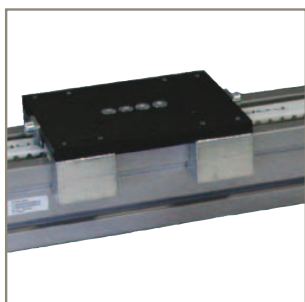
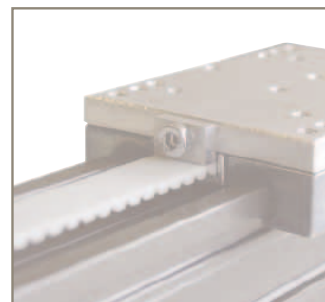

ENGINEERING YOUR SUCCESS.



WARNING – USER RESPONSIBILITY

FAILURE OR IMPROPER SELECTION OR IMPROPER USE OF THE PRODUCTS DESCRIBED HEREIN OR RELATED ITEMS CAN CAUSE DEATH, PERSONAL INJURY AND PROPERTY DAMAGE.

- This document and other information from Parker-Hannifin Corporation, its subsidiaries and authorized distributors provide product or system options for further investigation by users having technical expertise.
- The user, through its own analysis and testing, is solely responsible for making the final selection of the system and components and assuring that all performance, endurance, maintenance, safety and warning requirements of the application are met. The user must analyze all aspects of the application, follow applicable industry standards, and follow the information concerning the product in the current product catalog and in any other materials provided from Parker or its subsidiaries or authorized distributors.
- To the extent that Parker or its subsidiaries or authorized distributors provide component or system options based upon data or specifications provided by the user, the user is responsible for determining that such data and specifications are suitable and sufficient for all applications and reasonably foreseeable uses of the components or systems.

Compact Linear Actuator - LCB

Overview	5
Technical Data	8
Load Diagrams / Wear	9
Location of Mass or Point of Force Application	12
Required Drive Torque	13
Deflection vs. Distance between Mountings and Payload	14
Dimensions	15
Accessories and Options	17
Sliding Block	17
External Buffers	17
Clamping Profiles	18
T-Nuts/Bolts	19
Electrical Limit Switches	20
Coupling Kits	21
Shaft Kit for Dual Axis Actuators	22
PTN Economy Planetary Gearbox for the LCB Compact Linear Actuator	23
Order Code	25
Order Code LCB Linear Actuator (Basic Unit)	26
Order Code for the LCB Coupling Kit	27
Order Code LCB Shaft Kit (for Dual Axis Actuators)	27
Gear Unit	28

Parker Hannifin

The global leader in motion and control technologies

A world class player on a local stage

Global Product Design

Parker Hannifin has more than 40 years experience in the design and manufacturing of drives, controls, motors and mechanical products. With dedicated global product development teams, Parker draws on industry-leading technological leadership and experience from engineering teams in Europe, North America and Asia.

Local Application Expertise

Parker has local engineering resources committed to adapting and applying our current products and technologies to best fit our customers' needs.

Manufacturing to Meet Our Customers' Needs

Parker is committed to meeting the increasing service demands that our customers require to succeed in the global industrial market. Parker's manufacturing teams seek continuous improvement through the implementation of lean manufacturing methods throughout the process. We measure ourselves on meeting our customers' expectations of quality and delivery, not just our own. In order to meet these expectations, Parker operates and continues to invest in our manufacturing facilities in Europe, North America and Asia.

Electromechanical Worldwide Manufacturing Locations

Europe

Littlehampton, United Kingdom
 Dijon, France
 Offenburg, Germany
 Filderstadt, Germany
 Milan, Italy

Asia

Wuxi, China
 Chennai, India

North America

Rohnert Park, California
 Irwin, Pennsylvania
 Charlotte, North Carolina
 New Ulm, Minnesota



Offenburg, Germany

Local Manufacturing and Support in Europe

Parker provides sales assistance and local technical support through a network of dedicated sales teams and authorized technical distributors throughout Europe.

For contact information, please refer to the Sales Offices on the back cover of this document or visit www.parker.com



Milan, Italy



Littlehampton, UK

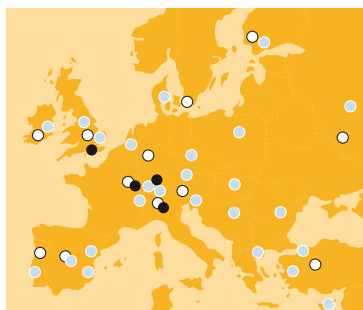

- Electromechanical Manufacturing
- Parker Sales Offices
- Distributors



Dijon, France

Compact Linear Actuator - LCB

Overview

Description

LCB is a compact, robust linear actuator with an external sliding guidance system and integrated toothed belt drive. The construction is simple, economic and robust, which makes LCB a cost-effective alternative to traditional toothed belt actuators.

Typical areas of application

- Pick-&-Place applications
- Packaging, labeling and wrapping systems
- Sensor and format adjustment (e.g. back-stop)
- Pusher-, picker- and gripper applications
- Positioning
- Feeding
- Cutting

Features

- Low purchase and installation costs
- Low operating costs:
 - Maintenance-free (up to the wear limit of the sliding carriage)
 - Changing the replaceable slide can be carried out within a few minutes
 - High service life
 - Due to the low moving mass, energy costs are reduced
- Motion is controlled using modern servo or stepper motor technology. This allows any required position or velocity profile to be achieved
- Even at high speeds the LCB generates very little noise
- The slide guidance system is clean and dry. There is no need for lubrication that can attract dust particles.
- The sliding guide system has a high static load bearing capacity
- Simple mounting
 - Integrated grooves allow for easy assembly of the LCB. Additional components such as limit switches can also be fitted with no restrictions on the position along the groove.
- The LCB is available in 2 sizes and with drive packages
 - as components with free shaft end
 - fitted with a gearbox
 - with a gearbox and servo or stepper motor drive
 - with a gearbox and servo motor combined with a matching closed loop controller from Parker (Compax3 or SLVD)
 - with a (direct-drive option) servo motor and Compax3 servo controller
 - with a stepper motor (direct drive option)

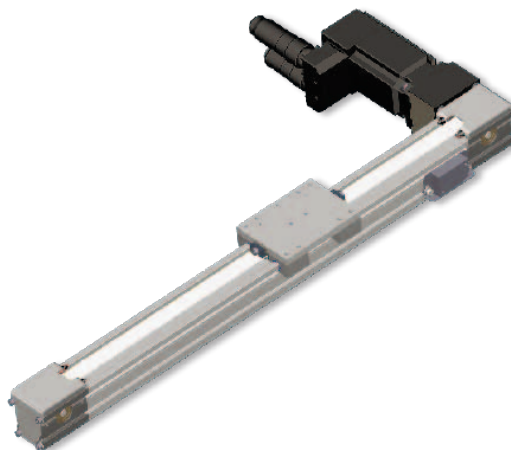

Technical Characteristics - Overview

Module type	Linear Actuator with Toothed Belt Drive	
Frame size	LCB040	LCB060
Speed	up to 8 m/s	
Acceleration	up to 20 m/s ²	
Load capacity	1250 N	3850 N
Total Stroke	2000 mm	5500 mm
Thrust force	160 N	560 N
Typical payload	1...6 kg	1...30 kg
Repeatability	±0.2 mm	

LCB - Compact Linear Actuator
Overview

Cross section M1:1

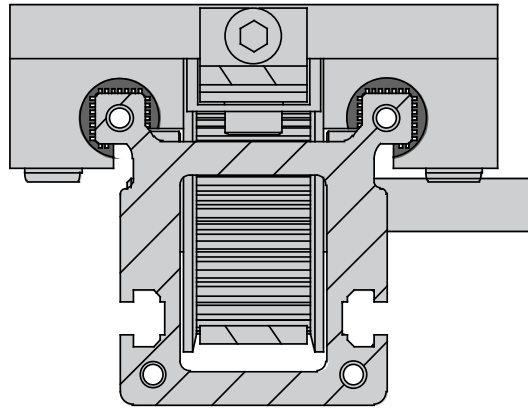

LCB040

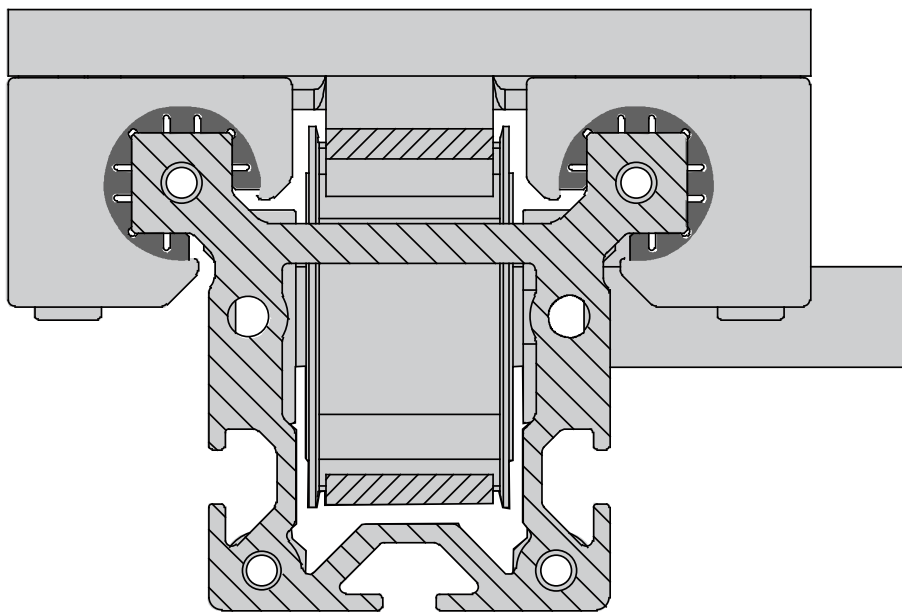

LCB060

(protection of utility patents: 20 2004 014 821.8)

Product Design

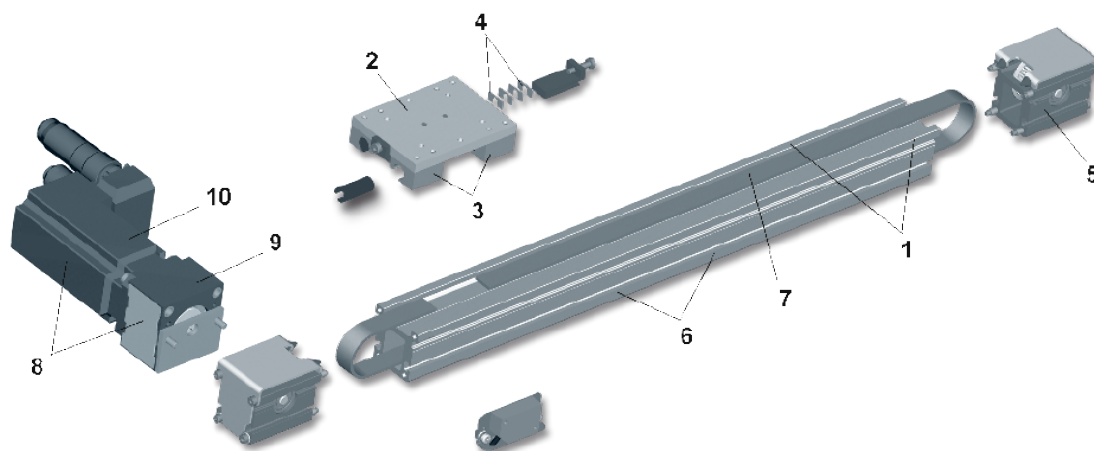

The LCB is protected by registered design No. 20 2004 014 821.8

Guide (1) / sliding carriage (2):

- The external sliding guide is incorporated as part of the aluminum profile. The guiding rails do not have to be aligned.
- The sliding carriage is available in three lengths. With a longer sliding carriage there is greater distance between the sliding blocks (3) and this improves the load capacity with respect to yawing and pitching moments.
- Maintenance-free sliding guiding with integrated dry-film lubricant.
- Sliding carriage (3) can be easily changed within 2 minutes without detensioning the toothed belt.
- The toothed belt of LCB40 is tensioned directly at the sliding carriage by means of spacer plates (4).
On the LCB060, the toothed belt is tensioned via tensioning screws at the tensioning station (5).
- The low moving mass allows highly-dynamic movement to be achieved and saves operating power.

Profile (6):

- Available in 2 sizes
- High resistance to flexing
- High torsional stiffness (due to the closed profile)
- Compact design, optimum space utilization
- Dirt tolerant, chemically and mechanically robust

Toothed belt drive (7):

- High stiffness and accuracy provided by the generously-dimensioned toothed belt.

Drive (8):

- Drive options:
 - Linear actuator with free shaft end
 - Coupling (9) & gearbox
 - Coupling + gearbox/motor combination (stepper or servo)
 - Coupling, gearbox, motor and controller
 - Coupling and motor (10) (direct-drive with Compax3)

Right/left Indication

Looking from load attachment plate to drive module.

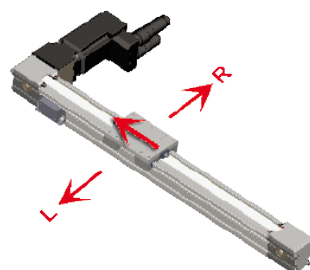

Technical Data

The technical data apply under normal conditions and only for the individual operating and load mode. In the case of compound loads, it is necessary to verify in accordance with normal physical laws and technical standards whether individual ratings should be reduced. In case of doubt please contact Parker Hannifin.

LCB - Size	Unit	LCB040	LCB060
Travels, speeds and accelerations			
Maximum travel speed	[m/s]	5	8
Maximum acceleration	[m/s ²]	20	20
Maximum stroke	[mm]	2000	5500
Torques, forces, dimensions of pulley and timing belt			
Travel distance per revolution	[mm/U]	125	170
Diameter of pulley	[mm]	39.79	54.11
Toothed belt width / pitch	[mm]	16 / 5	25 / 10
Weight of toothed belt	[kg/m]	0.048	0.167
maximum drive torque	[Nm]	3.2	15.2
Static load capacity in normal direction	[N]	1250	3850
max. thrust force (effective load)	[N]	160	560
Repeatability	[mm]	±0.2	±0.2
Weights, mass moments of inertia			
Weight of base unit without stroke			
LCB with short sliding carriage	[kg]	1.47	4.33
LCB with medium sliding carriage	[kg]	1.66	4.71
LCB with long sliding carriage	[kg]	1.85	5.10
Weight of moved mass with short sliding carriage	[kg]	0.39	1.41
Weight of moved mass with medium sliding carriage	[kg]	0.46	1.53
Weight of moved mass with long sliding carriage	[kg]	0.53	1.66
Additional weight per meter of stroke	[kg/m]	2.45	5.21
Mass moment of inertia relative to the drive shaft			
LCB with free shaft, short sliding carriage, 1 m of stroke	[kgmm ²]	244	1483
LCB with free shaft, medium sliding carriage, 1 m of stroke	[kgmm ²]	272	1580
LCB with free shaft, long sliding carriage, 1 m of stroke	[kgmm ²]	300	1672
Mass moment of inertia of coupling	[kgmm ²]	1	6
Additional mass moment of inertia due to the weight of the toothed belt per meter of stroke	[kgmm ² /m]	37	500
Overall dimensions & physical data			
Length with short sliding carriage, zero stroke	[mm]	246	378
Length with medium sliding carriage, zero stroke	[mm]	296	428
Length with long sliding carriage, zero stroke	[mm]	346	478
Cross-section	[mm x mm]	40 x 60 x 73	60 x 90 x 120
Moment of inertia I _x	[cm ⁴]	17.93	92.9
Moment of inertia I _y	[cm ⁴]	17.79	109.3
Moment of inertia I _t	[cm ⁴]	35.68	202.2
E-modulus (aluminum)	[N/mm ²]	0.72 x 10 ⁵	
Temperature data			
Temperature range	-20 °C to +60 °C The nominal data are valid for ambient temperatures between +15 °C and +30 °C.		

Technical data considering safety factor S=1.

Load Diagrams / Wear

Prerequisites:

The diagrams apply for ideal operating conditions, faultless guidings provided. Please note that they are only valid for the guiding. The diagrams are based on a trapezoidal motion profile consisting of 3 equally long distances for acceleration, constant travel and deceleration.

The diagrams are normalized on defined payloads:
LCB040 with 1 kg,
LCB060 with 5 kg.

Shown are the respective mass centroids with their typical load arms.

Lifetime:

Naturally, the sliding guide already has a small amount of play from new so that the guide does not jam and the sliding carriage moves smoothly. The play is measured as a gap for each slide and is approx. 0.1 to 0.2 mm in normal direction and at the sides.

During operation, play increases according to the loads shown in the diagrams.

If the slide has worn, or reached the wear limit (0.5 mm for LCB040, 1.0 mm for LCB060), the slides can easily be changed within a few minutes. Once replaced, the life of the product is effectively renewed and once again follows the Load/wear diagrams.

Use of the diagrams:

The diagrams can be interpolated with respect to lifetime and extrapolated with respect to load (for example: halved operational performance results in halved wear, doubled load will result in halved mileage in km).

LCB040 - Lifetime / Sliding blocks for different mass centroids with their load arms.

Normalized payload 1 kg

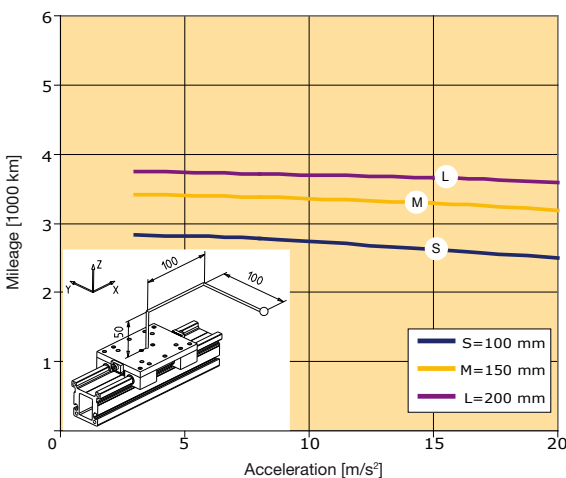
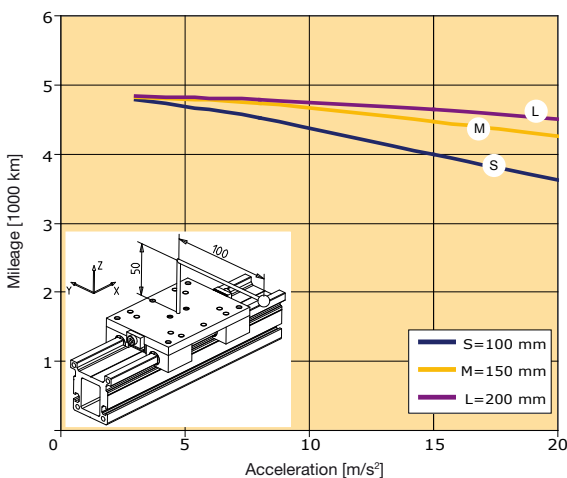
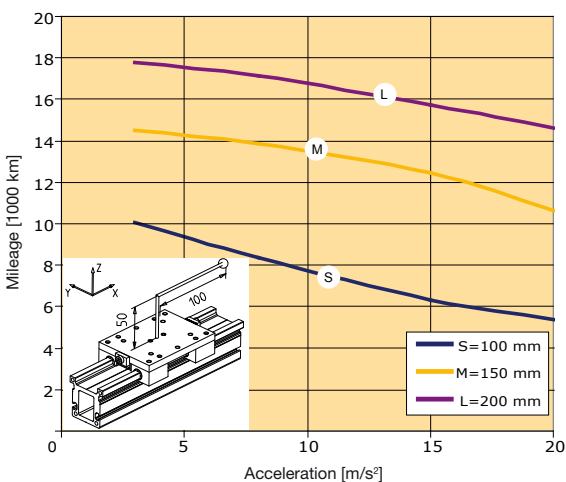
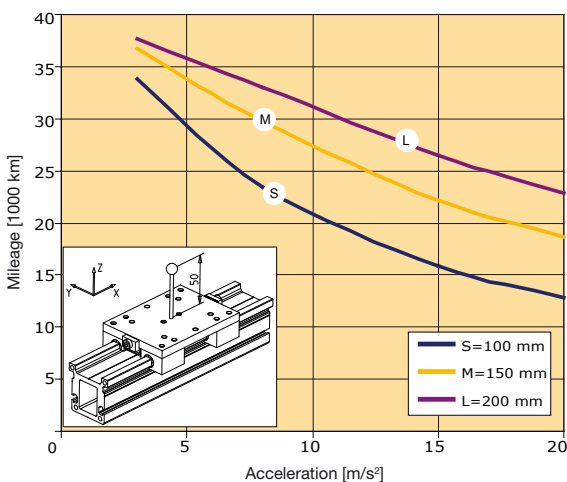

LCB - Compact Linear Actuator
Technical Data

LCB040 - Lifetime / Sliding blocks for different mass centroids with their typical load arms.
Normalized payload 1 kg

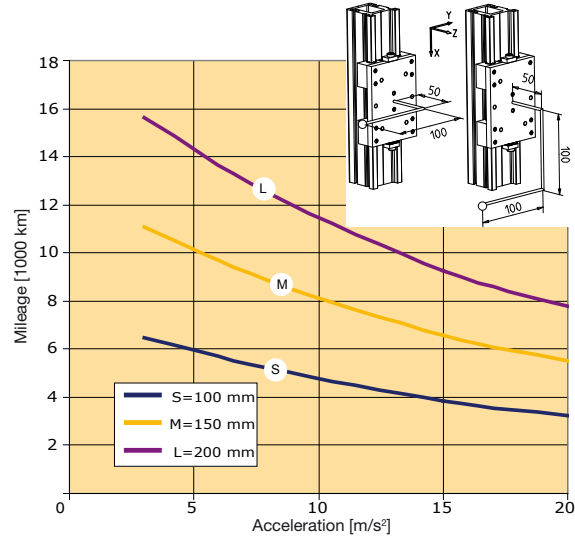
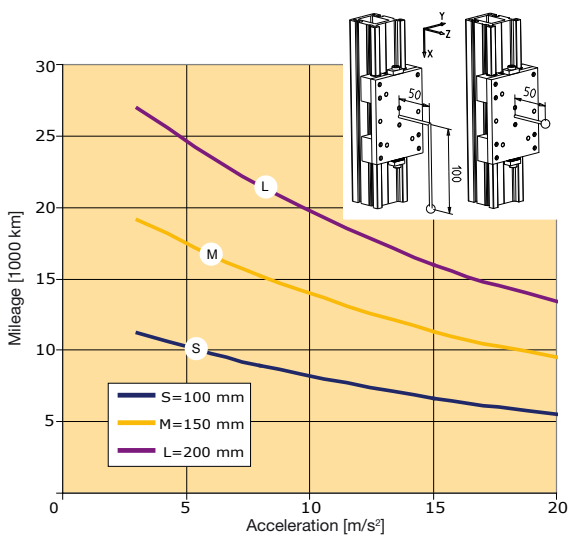
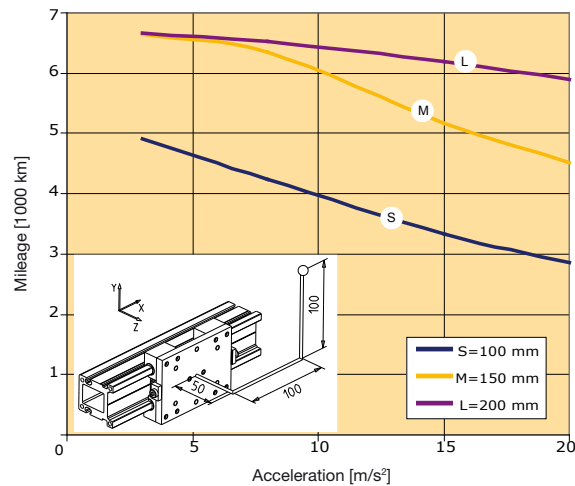
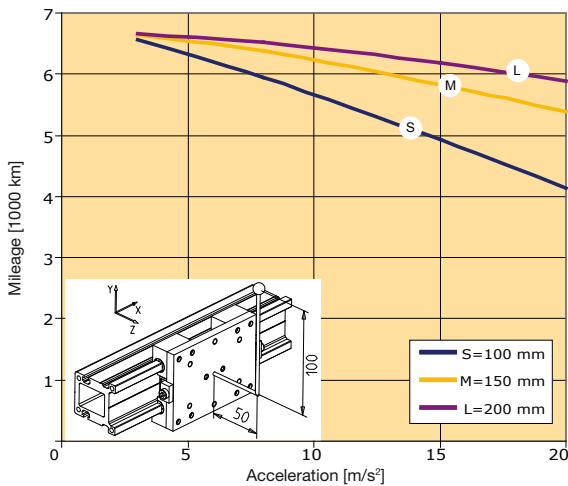
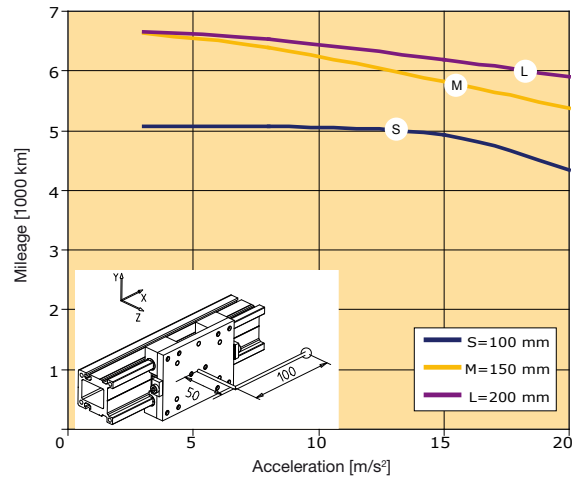
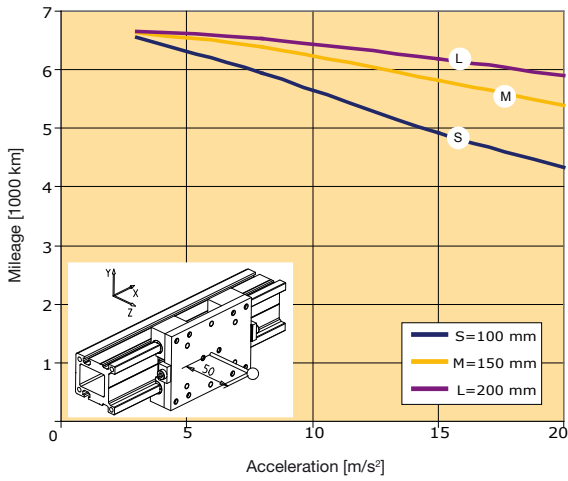

LCB060 - Lifetime / Sliding blocks for different mass centroids with their typical load arms
Normalized payload 5 kg

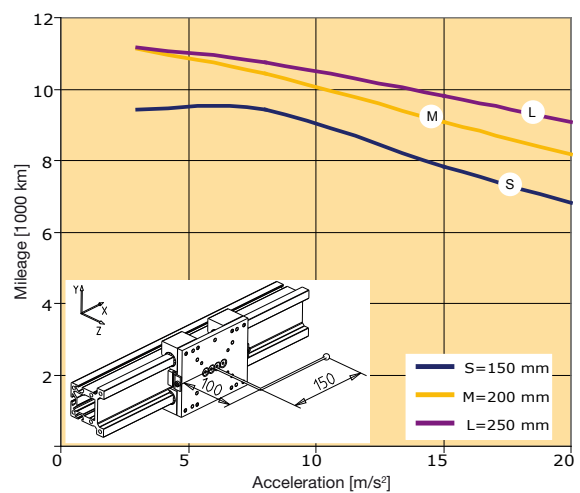
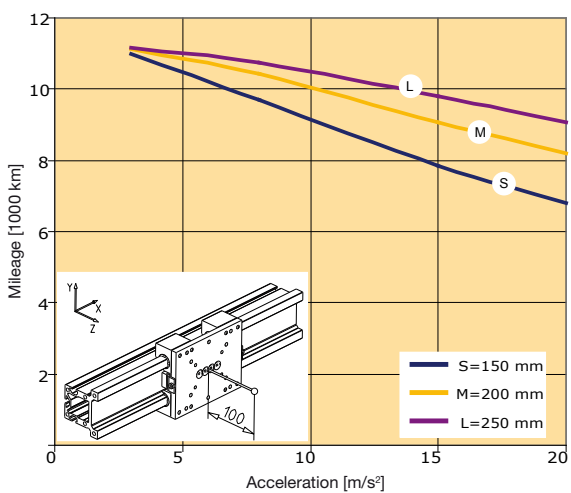
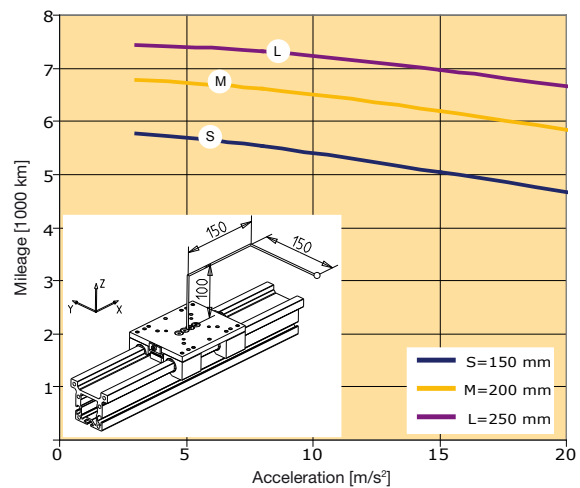
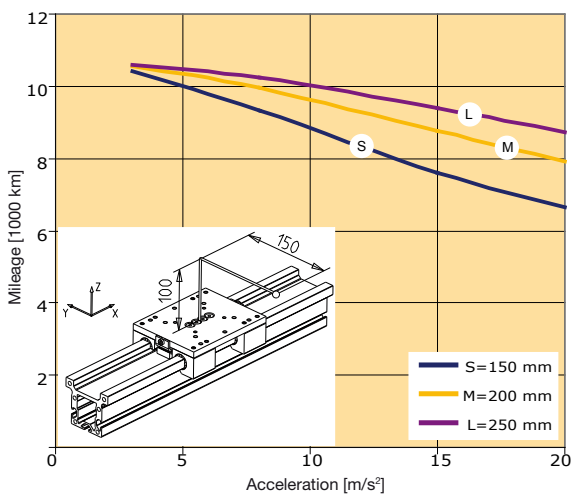
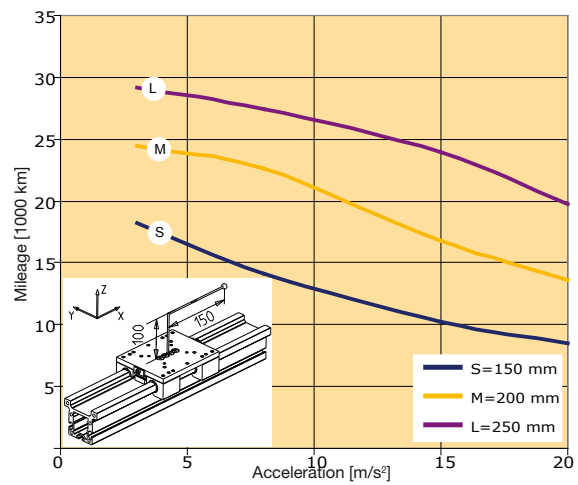
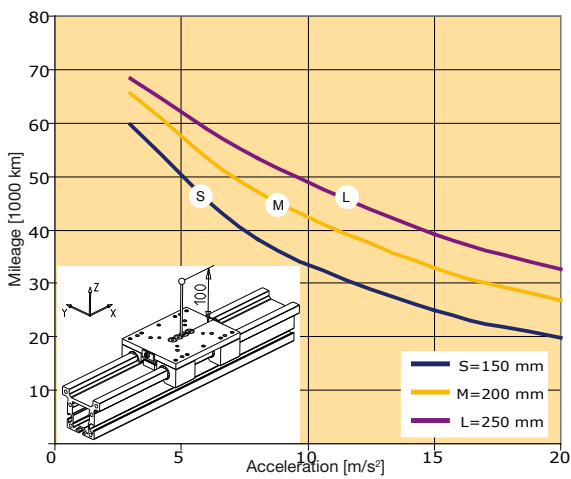

LCB060 - Lifetime / Sliding blocks for different mass centroids with their typical load arms

Normalized payload 5 kg

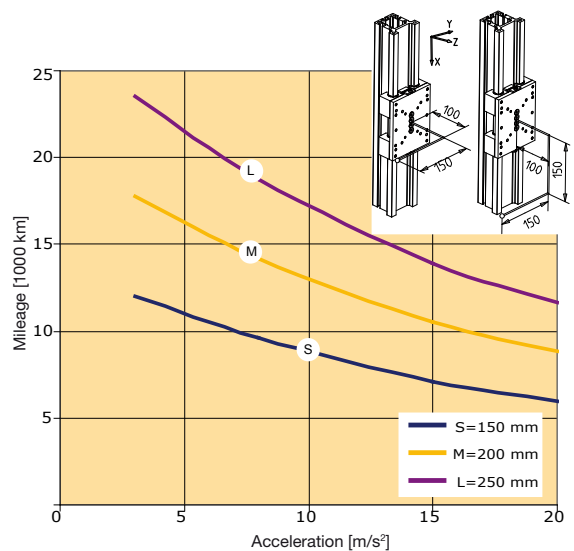
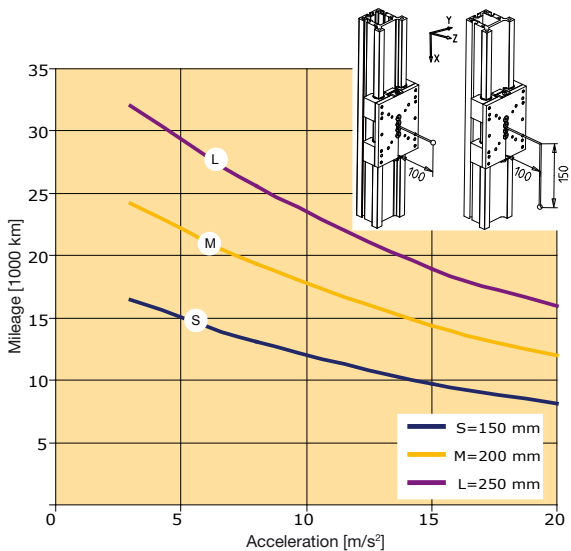
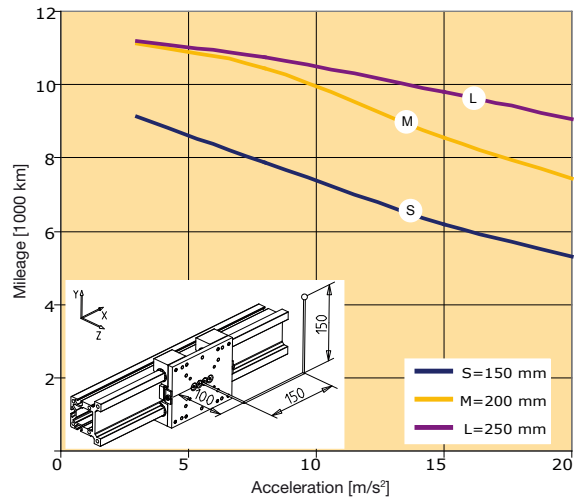
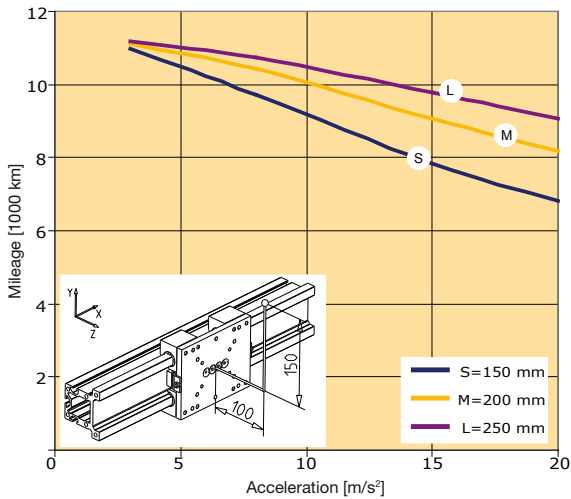

Location of Mass or Point of Force Application

2:1 rule

The displayed example of a pitching moment is also valid for rolling and yawing moments respectively.

- l_L = Load lever
- l_T = Support lever
- * = Exact point of force application

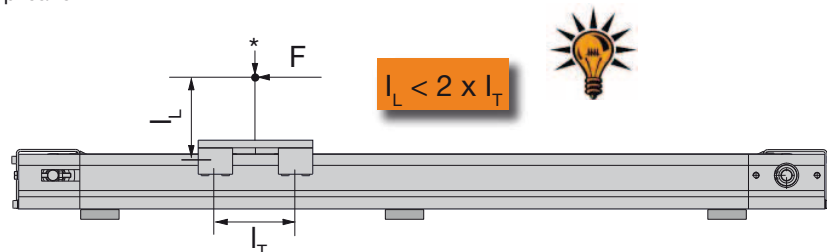

Required Drive Torque



The diagrams include both acceleration and friction forces!
The values displayed are valid for averaged kinetic friction.

LCB040 - required drive torque

horizontal mounting position

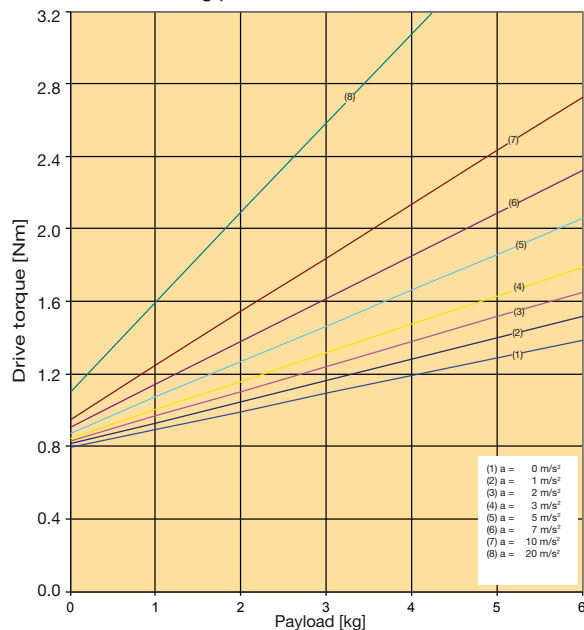

(1): Constant movement
(2) - (8): Acceleration

vertical mounting position (upward acceleration)

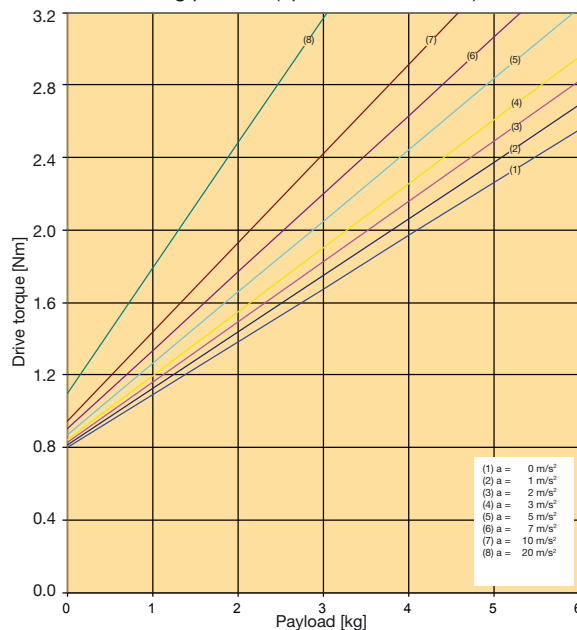

LCB060 - Required drive torque

horizontal mounting position

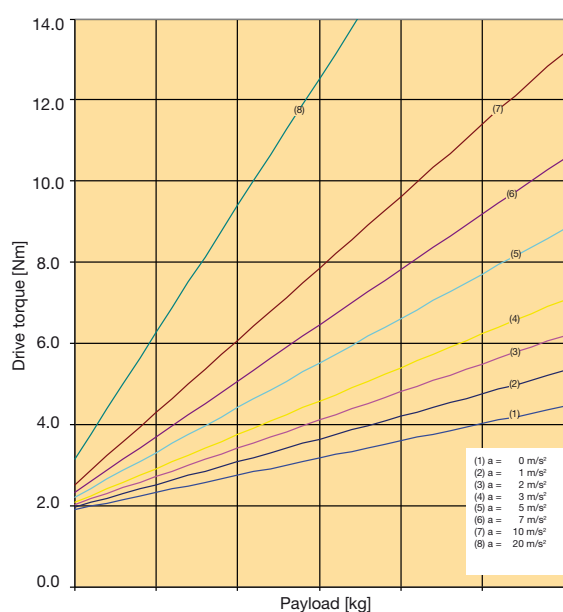

(1): Constant movement
(2) - (8): Acceleration

vertical mounting position (upward acceleration)

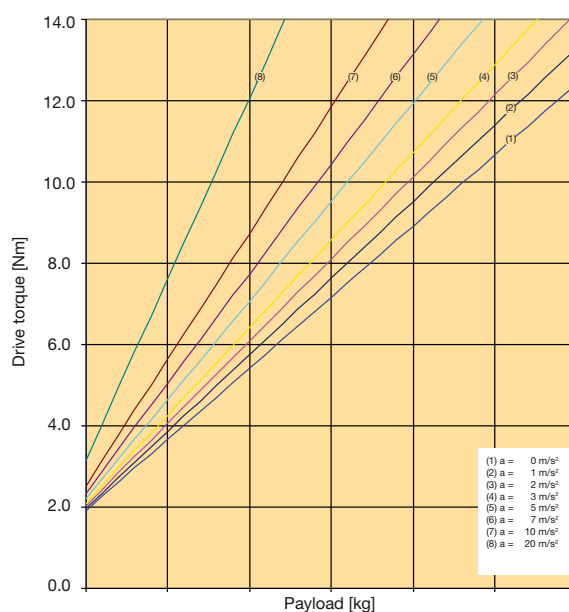

Deflection vs. Distance between Mountings and Payload

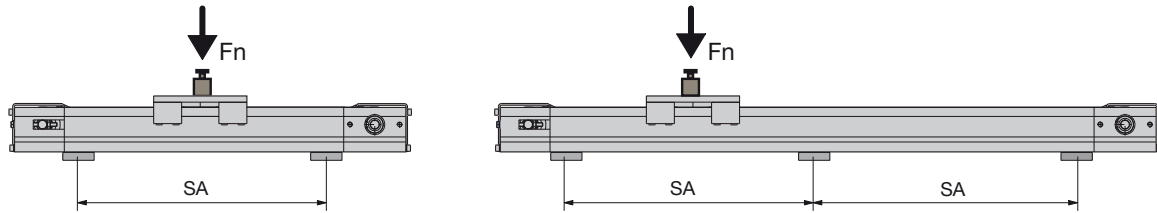

LCB040

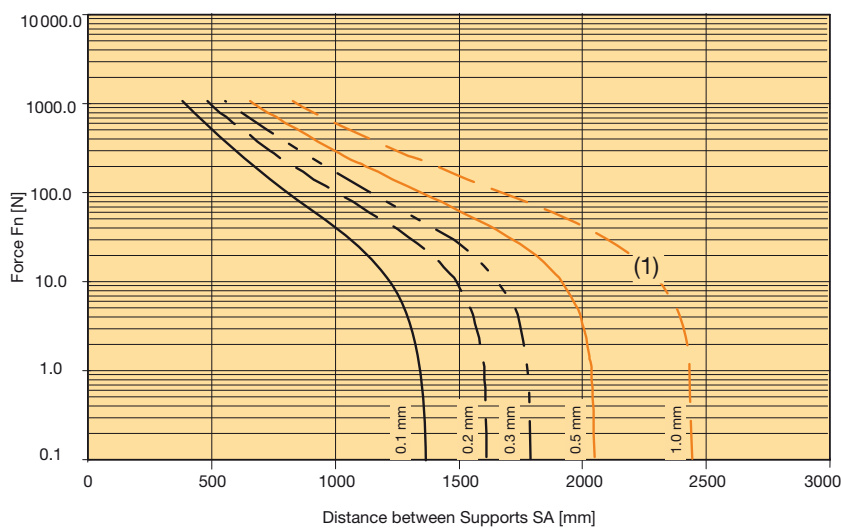

LCB060

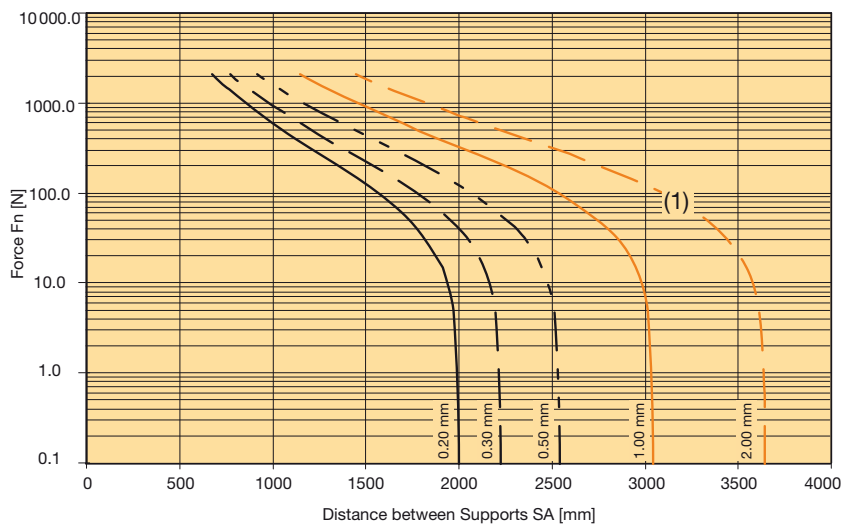

(1): Max. permissible deflection

LCB - Compact Linear Actuator Technical Data

Dimensions

LCB040 Linear actuator

3D-CAD Data: www.parker.com/eme/lcb

Dimensions [mm]

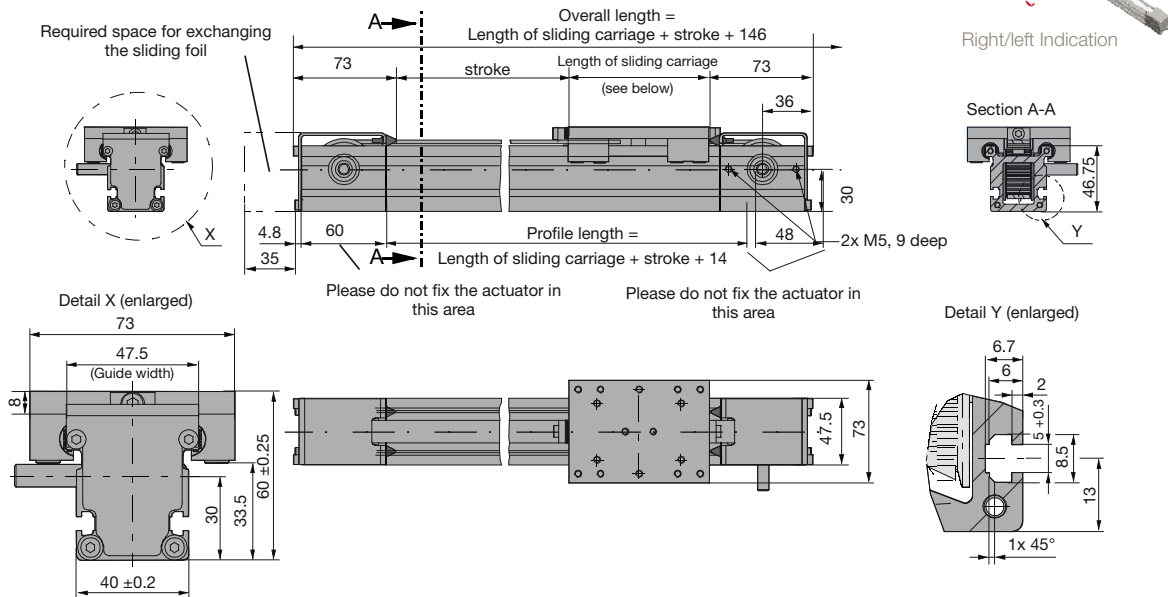

Length of sliding carriage

All sliding carriages have 4 sliding blocks.
On a longer sliding carriage the load bearing capacity for yawing and pitching moments is greater (M_y and M_z).

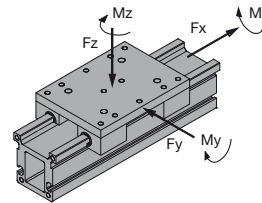

Carriage options

Short sliding carriage S

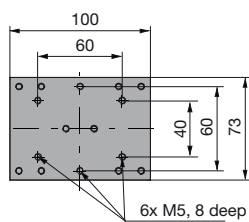

Medium sliding carriage M

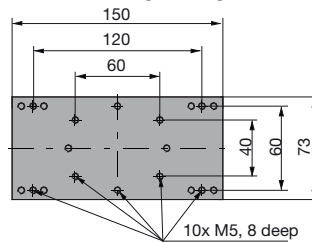

Long sliding carriage L

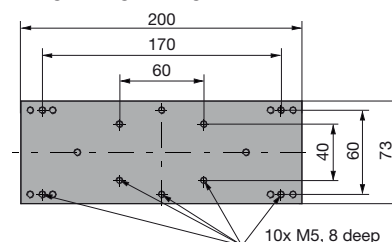

Drive options

Drive station SL

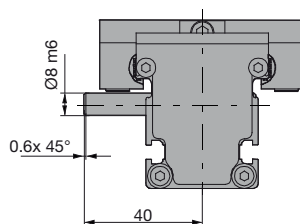

Drive station SR

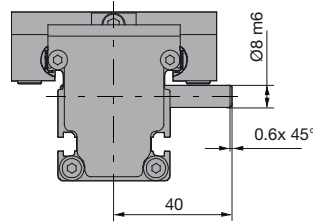

Drive station BL/BR

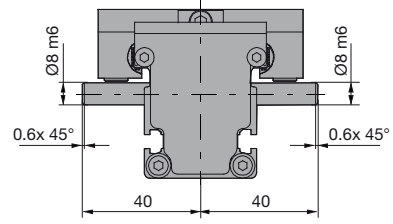

LCB - Compact Linear Actuator
Technical Data

LCB060 Linear actuator

3D-CAD Data: www.parker.com/eme/lcb

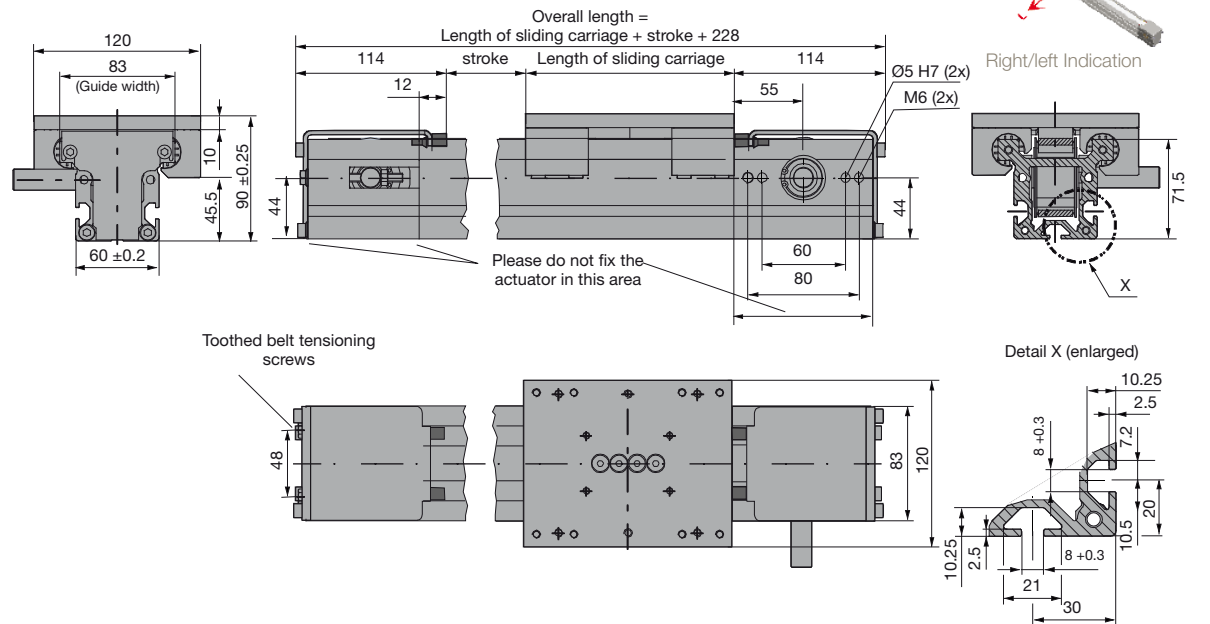

Length of sliding carriage

All sliding carriages have 4 sliding blocks.
On a longer sliding carriage the load bearing capacity for yawing and pitching moments is greater (M_y and M_z).

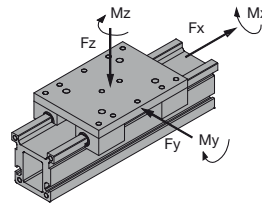

Carriage options

Short sliding carriage S

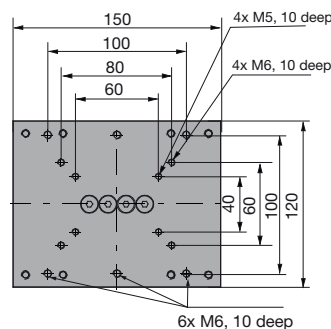

Medium sliding carriage M

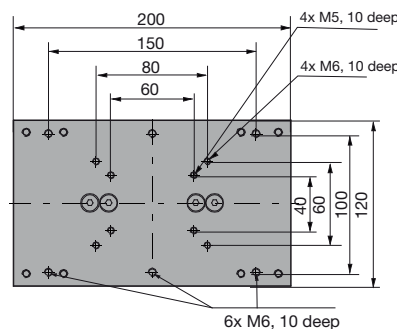

Long sliding carriage L

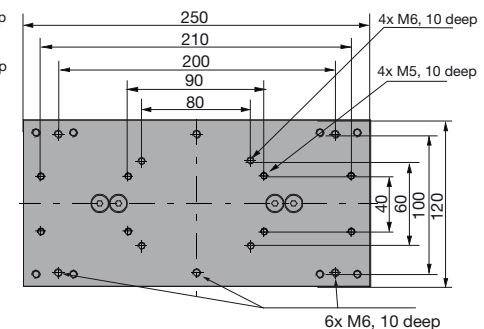

Drive options

Drive station SL

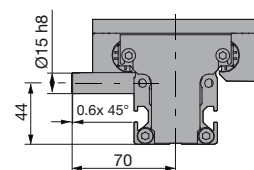

Drive station SR

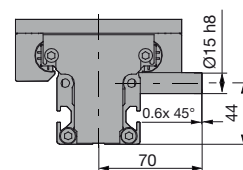

Drive station BL/BR

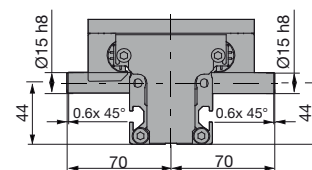

Accessories and Options

Sliding Block

The sliding block is a wearing part.
You need 4 pieces per linear actuator .

Type	Code	Art. No.
LCB040	Sliding bearing block	127-004016
LCB060	Sliding bearing block	127-006014

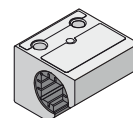

We recommend to have at least 4 sliding blocks on stock.

External Buffers

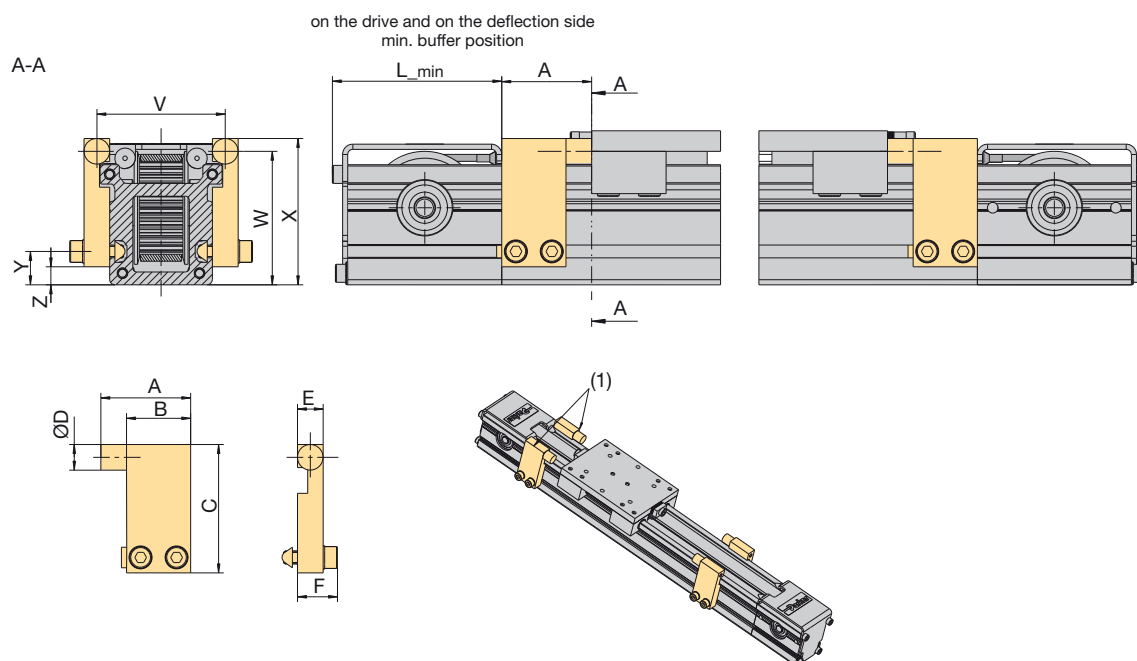

(1) We recommend 2 external buffers are fitted per side.

Type	Code	Art. No.	Art. No.	A	B	C	ØD	E	F
			stainless	[mm]					
LCB040	buffer assembly	510-001445	510-001495	35	25	50	10	10	15.6
LCB060	buffer assembly	510-001645	510-001695	55	40	85	15	20	26.7

Type	L_min	V	W	X	Y	Z
	[mm]					
LCB040	66	50	52	57	13	7
LCB060	97	80	82.5	90	20	5

LCB - Compact Linear Actuator
Accessories and Options

Clamping Profiles

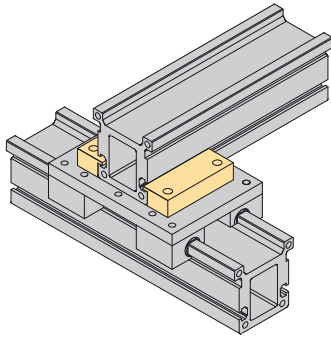

The toe clamps are used in conjunction with the standard load attachment plate to rapidly install and attach various combinations of linear actuators. Two clamping profiles are needed to fix a LCB on a flange plate. (The clamping profiles may not be used in the area of the drive- or of the clamping station).

LCB040

Dimensions [mm]

Type	Code	Art. No.
LCB040	Toe Clamp	500-000910

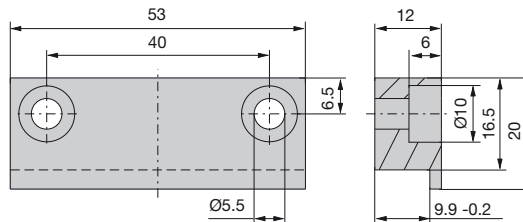
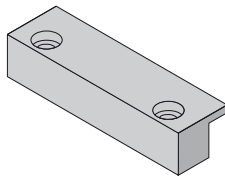

LCB060

Type	Code	Art. No.
LCB060	Toe clamp $\varnothing 9$ mm	500-000901
LCB060	Toe Clamp $\varnothing 6.6$ mm	500-000905

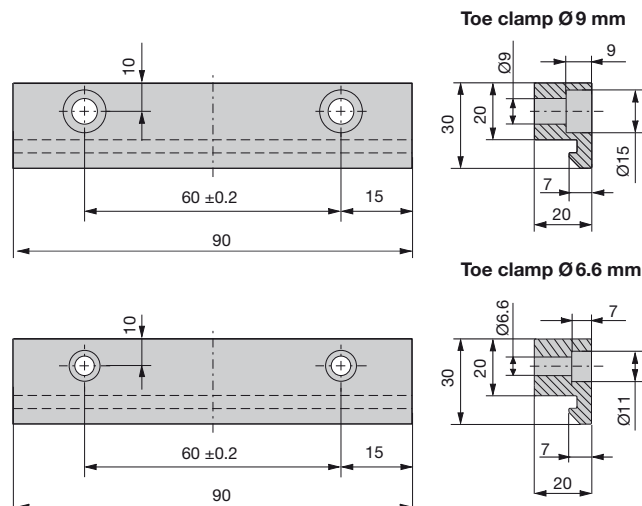
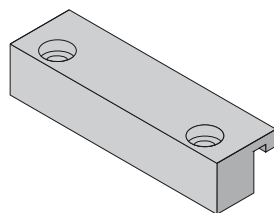

T-Nuts/Bolts

The T-nuts and bolts are used to attach external components to the T-grooves of the profile

Nuts

Dimensions [mm]

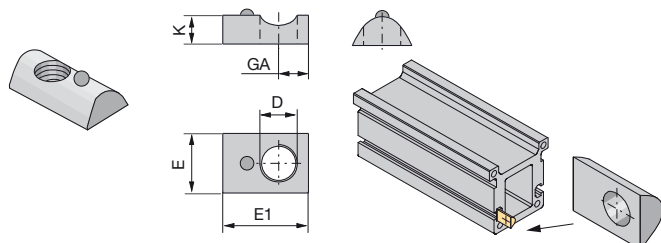

T slot bolts and nuts

DIN 787

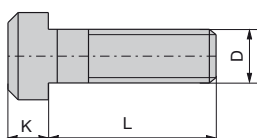
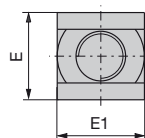
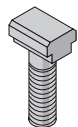

DIN 562

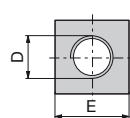
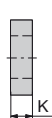

DIN 934

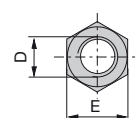

Type	Code	D	E	E1	K	GA	L	Art. No.
LCB040	Nut	M4	8	11.5	4	4	--	127-004020
LCB040	Nut	M5	8	11.5	4	4	--	127-004021
LCB040	DIN 562-M4 square nut*	M4	7	--	2.2	--	--	135-700001
LCB040	DIN 562-M5 square nut*	M5	8	--	2.7	--	--	135-700003
LCB040	DIN 934-M4 hexagon nut*	M4	7	--	2.9	--	--	135-700600
LCB040	DIN 934-M5 hexagon nut*	M5	8	--	3.7	--	--	135-700700
LCB060	T-bolt DIN787 M8 x 8 x 25	M8	13	13	6	--	25	131-700001
LCB060	T-bolt DIN787 M8 x 8 x 32	M8	13	13	6	--	32	131-700002
LCB060	T-bolt DIN787 M8 x 8 x 40	M8	13	13	6	--	40	131-700003
LCB060	Nut	M4	13.7	22	7	7.5	--	127-006015
LCB060	Nut	M5	13.7	22	7	7.5	--	127-006016
LCB060	Nut	M6	13.8	23	7.3	5.5	--	400-000033
LCB060	Nut	M8	13.8	23	7.3	7.5	--	400-000034

* Square and hexagon nuts should only be used for lightly-loaded attachments

Electrical Limit Switches

Dimensions [mm]

LCB040

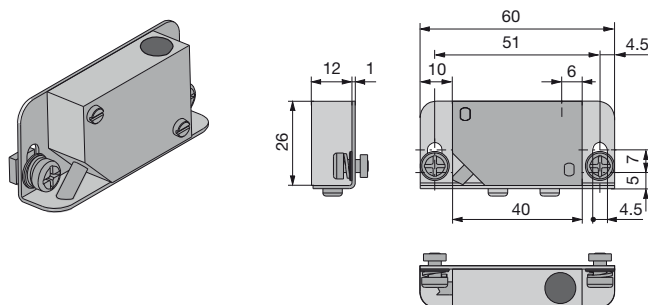

LCB060

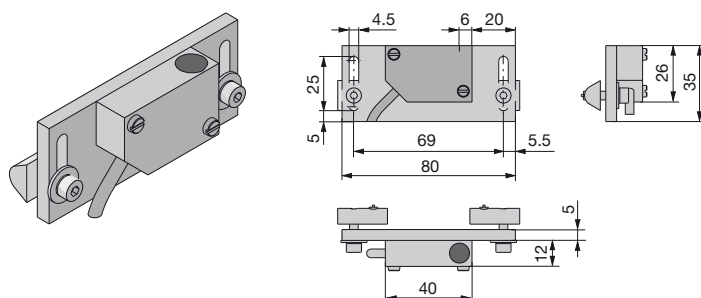

Connection diagram LCB040 and LCB060

Technical data limit switches LCB040 and LCB060	
Switching distance	2 mm / 4 mm \pm 10 %
Switch hysteresis	>1 %...<15 %
Repeatability	0.01 mm
Temperature drift	<10 %
Ambient temperature	-25 °C...+70 °C
Protection class	IP67
Cable length	6 m
Electrical characteristics	
Rated voltage	24 VDC
Voltage range	10...35 VDC
Supply current	<15 mA
Maximum load current	300 mA
Residual voltage	<2.5 VDC
Switching Frequency	2 kHz
Connecting cables	3x0.25 mm ²

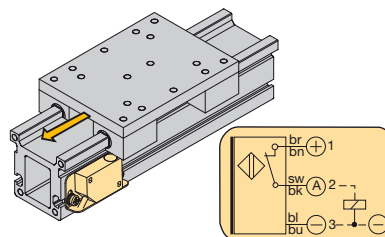

1: PNP normally closed contact
2-3: Load

Type	Code	Art. No.
LCB040	Electrical limit switch NPN normally closed contact with 6 m cable and fixing material	510-001435
LCB040	Electrical limit switch NPN normally open contact with 6 m cable and fixing material	510-001436
LCB040	Electrical limit switch PNP normally closed contact with 6 m cable and fixing material	510-001437
LCB040	Electrical limit switch PNP normally open contact with 6 m cable and fixing material	510-001438
LCB060	Electrical limit switch NPN normally closed contact with 6 m cable and fixing material	510-001635
LCB060	Electrical limit switch NPN normally open contact with 6 m cable and fixing material	510-001636
LCB060	Electrical limit switch PNP normally closed contact with 6 m cable and fixing material	510-001637
LCB060	Electrical limit switch PNP normally open contact, 6 m cable and fixing material	510-001638

Coupling Kits

LCB with attached coupling kits

If a coupling kit is ordered in combination with a basic unit, the items will be delivered completely mounted. BL and BR have an additional shaft on the opposite side of the coupling. This is used to attach the shaft kit for dual-axis actuators.

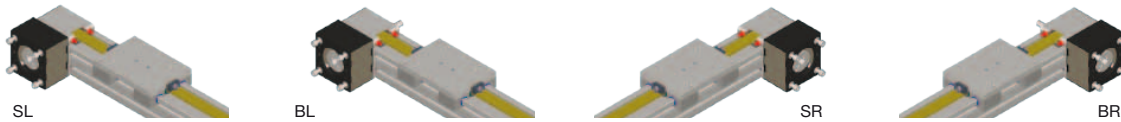

Drive options

Dimensions [mm]

Drive option L

LCB040 prepared for planetary gearbox PTN060

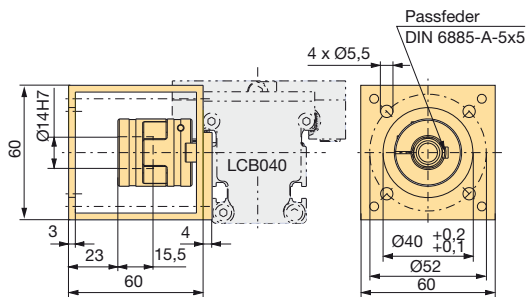

Drive option M

LCB060 prepared for planetary gearbox PTN080

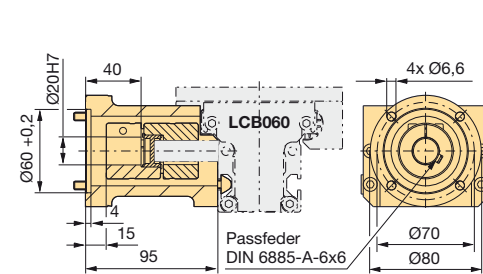

Drive option U

LCB040 prepared for servo motor SMH60 (direct drive)
only for single actuators with horizontal installation position

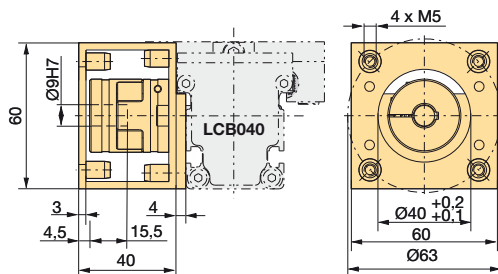

Drive option W

LCB060 prepared for servo motor SMH100 (direct drive)
only for single actuators with horizontal installation position

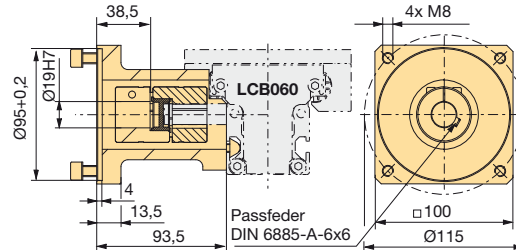

Drive option N

LCB040 prepared for stepper motor SY56 (direct drive)
only for single actuators with horizontal installation position

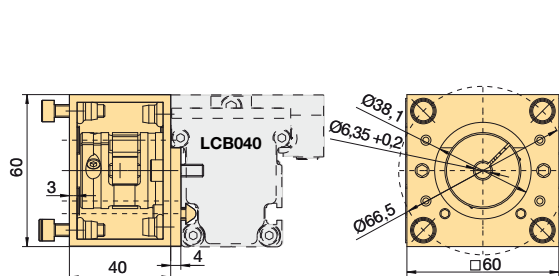

Drive option P

LCB060 prepared for stepper motor SY107 (direct drive)
only for single actuators with horizontal installation position

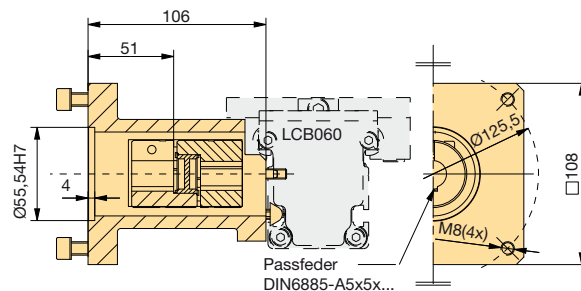

LCB - Compact Linear Actuator
Accessories and Options

Shaft Kit for Dual Axis Actuators

For a dual-axis actuator two LCB basic units and a shaft kit corresponding to the desired center-distance are required. Parker will deliver the two basic units (with mounted couplings - if this was ordered) and a separate shaft-kit.

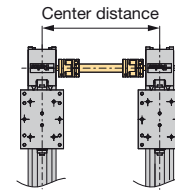

LCB040

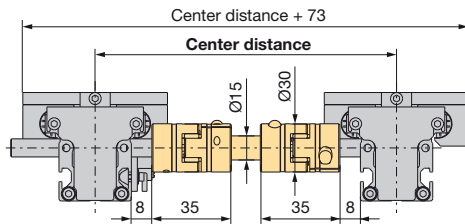

LCB060

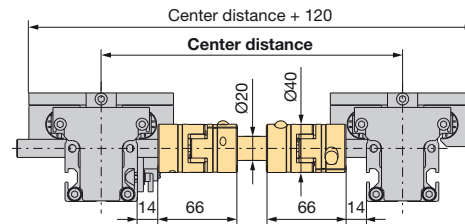

Possible double-axis configurations

For a dual-axis actuator with the drive on the left side you need two LCB basic units. The left unit with drive option BLN, the right unit with drive option SLN.

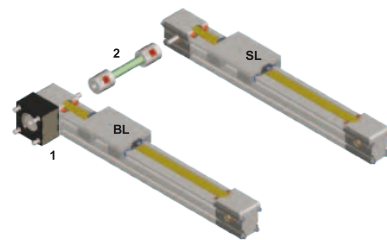

- 1: Coupling kit
- 2: Shaft kit

For a dual-axis actuator with the drive on the right side you need two LCB basic units. The right unit with drive option BRN, the left unit with drive option SRN.

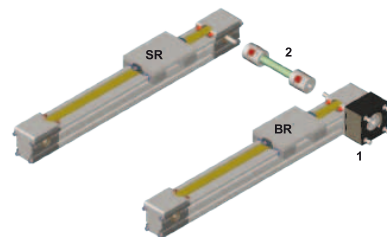

- 1: Coupling kit
- 2: Shaft kit

PTN Economy Planetary Gearbox for the LCB Compact Linear Actuator

PTN planetary gearbox in two sizes

Description

The economy series PTN planetary gearbox was developed for applications, where an extremely low backlash is not required.

- Space-saving design
- High output torques
- High efficiency (96 %)
- Low noise <65 dB (A)
- Life time lubrication
- High quality (ISO 9001)
- Fast and direct motor mounting
- Direction of rotation equidirectional
- Ratios: 4:1, 8:1, 25:1



Dimensions

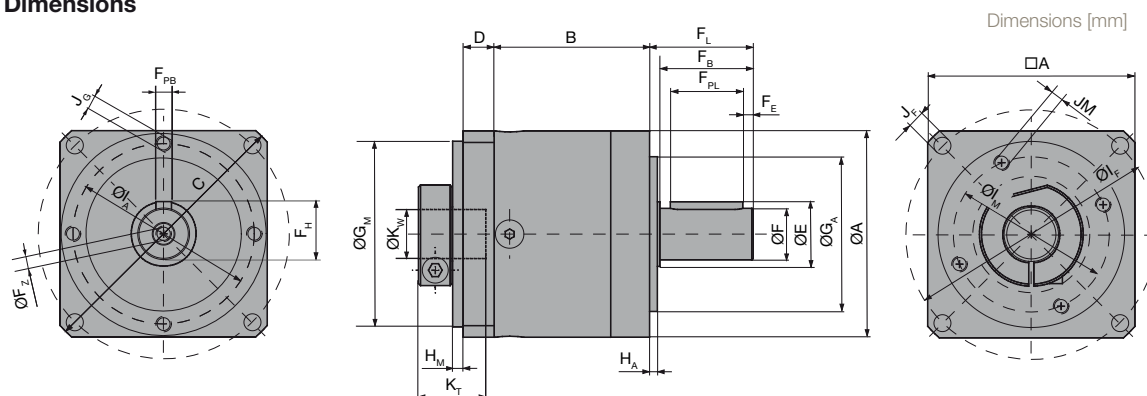

Gearbox size		PTN060	PTN080	F _{PL}	Length of keyway	25	28
A	Ø Housing □ Universal flange cross section	60	80	Gearbox size		PTN060	PTN080
B	Housing length (ratio 4:1, 8:1)	47	60	F _{PB}	Width of keyway	5	6
	Housing length (ratio 25:1)	59.5	77.5	G _A	Ø Output pilot (h7)	40	60
C	Diagonal dimension of universal flange	80	107	G _M	Ø Input pilot (h7)	52	72
D	Thickness of universal flange	8.2	12	H _A	Output pilot length	3	3
E	Ø Shaft collar	17	25	H _M	Output drive length	3	4
F	Ø Drive shaft (h7)	14	20	I _A	Ø Hole circle on pilot side	52	70
F _Z	Centre bore of drive shaft	M5x12	M6x16	I _M	Ø Hole circle on output side	44	60
F _L	Shaft length from face	35	40	I _F	Ø hole circle of universal flange	70	97
F _B	Usable shaft length	30	36	J _G	Mounting thread on pilot side	M5x8	M6x10
F _H	Shaft height with key	16	22.5	J _M	Mounting thread on output side	M5x8	M6x10
F _E	Distance from keyway to shaft end	2.5	4	J _F	Ø mounting thread universal flange	5.5	6.6
				K _W	Ø Input bore	9	19
				K _T	Input shaft bore depth	20	26

LCB - Compact Linear Actuator
Accessories and Options

Technical Data

Gearbox size	Unit	PTN060			PTN080		
		4:1	8:1	25:1	4:1	8:1	25:1
Ratio		4:1	8:1	25:1	4:1	8:1	25:1
Nominal torque	Nm	38	18	40	115	50	110
Backlash	arcmin	<16		<20	<12		<17
Torsional rigidity	Nm/arcmin	2.3		2.5	6		6.6
Noise emission	dB(A)	<58	<58	<60	<60		<65
Efficiency	%	>96	>94	>96	>94		>96
Weight	kg	0.9	1.1	2.1	2.6		6.0
Input speed ⁽¹⁾	min ⁻¹	4500			3400	4000	
Load on output shaft ⁽²⁾ radial	N	500			950		
Load on input shaft ⁽²⁾ axial	N	600			1200		
Operating temperature	°C	-25...+90					
Moment of Inertia	kgcm ²	0.093	0.065	0.075	0.52	0.39	0.44

⁽¹⁾ Intermittent operation, the max. permissible operating temperature is not to be exceeded.

⁽²⁾ Based on a lifetime of 20 000 hours - working cycle of 50 %

Order Code

The order code is structured as follows:

Basic unit:

"Order Code LCB Linear Actuator (Basic Unit)" see page 26

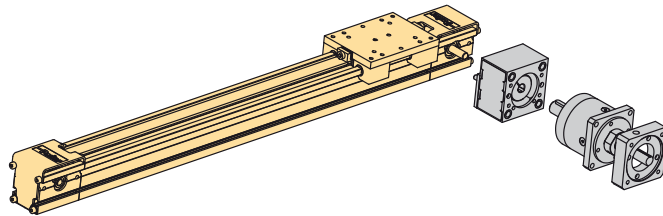

Coupling kit:

"Order Code for the LCB Coupling Kit" see page 27

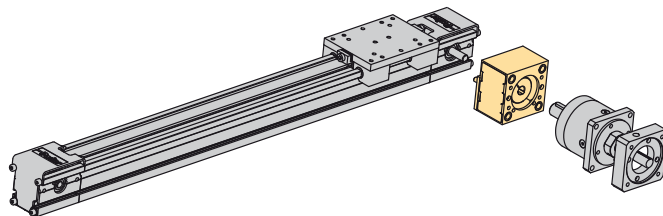

Shaft kit for dual axis actuators:

"Order Code LCB Shaft Kit (for Dual Axis Actuators)" see page 27

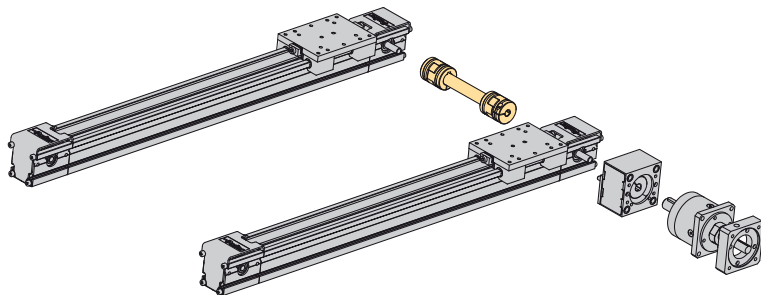

Gear unit:



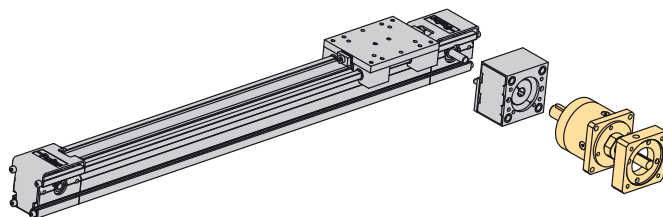

Gearbox: "Order Code PTN Economy Planetary Gearbox" see page 28

Motor kit: "Order Code for Motor Kit (Adapter Flange and Adapter Sleeve if applicable)" see page 28



LCB - Compact Linear Actuator
Order Code

Order Code LCB Linear Actuator (Basic Unit)

Example	LCB	040	M	G	00250	SR	N
Drive system							
LCB linear actuator	LCB						
Frame size							
040 (LCB040)		040					
060 (LCB060)		060					
Length of sliding carriage in mm							
	LCB040	LCB060					
Short sliding carriage	100	150		S			
Medium sliding carriage	150	200		M			
Long sliding carriage	200	250		L			
Special carriage (on request)				X			
Guide system							
Sliding guide				G			
Stroke in mm							
Depending on your application an additional safety travel on both sides of your travel path could be necessary.							
	LCB040	LCB060					
250	√	√			00250		
300	√	√			00300		
350	√	√			00350		
400	√	√			00400		
450	√	√			00450		
500	√	√			00500		
600	√	√			00600		
700	√	√			00700		
800	√	√			00800		
900	√	√			00900		
1000	√	√			01000		
1250	√	√			01250		
1500	√	√			01500		
1750	√	√			01750		
2000	√	√			02000		
2250	-	√			02250		
2500	-	√			02500		
2750	-	√			02750		
3000	-	√			03000		
3250	-	√			03250		
3500	-	√			03500		
3750	-	√			03750		
4000	-	√			04000		
4250	-	√			04250		
4500	-	√			04500		
4750	-	√			04750		
5000	-	√			05000		
5250	-	√			05250		
5500	-	√			05500		
Drive station and drive orientation							
	One drive shaft, drive on left					SL	
	One drive shaft, drive on right					SR	
	Two drive shafts (shaft on both sides), drive on left, only LCB040: Feather key groove DIN6885 - 2x2x10 on the left or on the right of the drive side					BL	
	Two drive shafts (shaft on both sides), drive on right, only LCB040: Feather key groove DIN6885 - 2x2x10 on the left or on the right of the drive side					BR	
Interface to the drive							
Mandatory statement							N

Order Code for the LCB Coupling Kit

				Example	LCB	040	K	L
Drive system								
LCB linear actuator					LCB			
Frame size								
040 (LCB040)						040		
060 (LCB060)						060		
Coupling kit*								
Coupling kit							K	
Drive Option (page 21)					LCB040	LCB060		
Prepared for Planetary Gearbox PTN060					√	-		L
Prepared for Planetary Gearbox PTN080					-	√		M
Prepared for servo motor (Direct drive) SMH60..B8, D=9 (for single actuator)					√	-		U
Prepared for servo motor (Direct drive) SMH100..B5, D=19 (for single actuator)					-	√		W
Prepared for stepper motor (direct drive) SY56 (for single actuator)					√	-		N
Prepared for stepper motor (direct drive) SY107 (for single actuator)					-	√		P

* Coupling kits are always mounted in the factory.

Order Code LCB Shaft Kit (for Dual Axis Actuators)

				Example	LCB	040	W	0250
Drive system								
LCB linear actuator					LCB			
Frame size								
040 (LCB040)						040		
060 (LCB060)						060		
Connecting shaft kit								
Connecting shaft kit							W	
Center distance (from center line to center line in mm)					LCB040	LCB060		
150 mm					√	-		0150
200 mm					√	-		0200
250 mm					√	√		0250
300 mm					√	√		0300
350 mm					√	√		0350
400 mm					√	√		0400
450 mm					√	√		0450
500 mm					√	√		0500
550 mm					√	√		0550
600 mm					√	√		0600
650 mm					√	√		0650
700 mm					√	√		0700
750 mm					√	√		0750
800 mm					√	√		0800
850 mm					√	√		0850
900 mm					√	√		0900
950 mm					√	√		0950
1000 mm					√	√		1000
1050 mm					-	√		1050
1100 mm					-	√		1100
1150 mm					-	√		1150
1200 mm					-	√		1200
1250 mm					-	√		1250
1300 mm					-	√		1300
1350 mm					-	√		1350
1400 mm					-	√		1400
1450 mm					-	√		1450
1500 mm					-	√		1500

LCB - Compact Linear Actuator
Order Code

Gear Unit

Order Code PTN Economy Planetary Gearbox

	Example	PTN	060	-	004	S7
Size [mm]						
Ø 060			060			
Ø 080			080			
Ratio						
4:1					004	
8:1					008	
25:1					025	
Shaft						
with keyway (standard)						S7

Order Code for Motor Kit (Adapter Flange and Adapter Sleeve if applicable)

	Example	M	003-321-000				
Motor kit							
M		M					
for PTN060							
Specifications [mm]	Pilot	Ø Hole circle	Ø Shaft	Shaft length	□ Adapter flange cross section	Z dimension Adapter flange	
SMH60-B08/9	40	63	9	20	60	16	003-321-000
SMH60-B05/11	60	75	11	23	70	16	051-000-000
SY56	Nema23 for SY56				60	16	060-140-000
for PTN080							
Specifications [mm]	Pilot	Ø Hole circle	Ø Shaft	Shaft length	□ Adapter flange cross section	Z dimension Adapter flange	
SMH60-B05/11	60	75	11	23	80	21.2	049-284-000
SMH82-B08/14	80	100	14	30	90	21.2	004-128-000
SMH82-B08/19	80	100	19	40	90	31.2	030-000-000
SY87	Nema34 for SY87				90	23.2	034-376-000
SY107	Nema42 for SY107				115	41.2	125-363-000

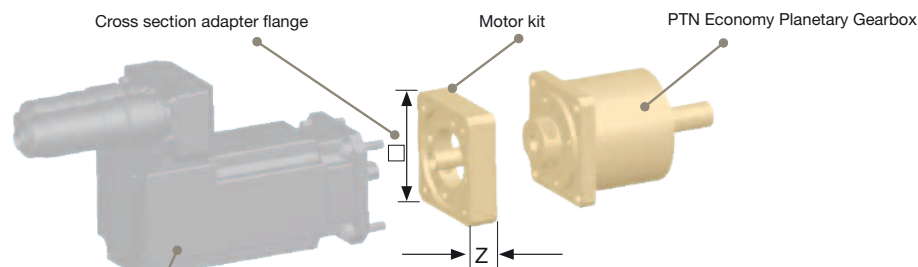

For motors please see
<http://www.parker.com/eme/smh>

LCB - Compact Linear Actuator
Order Code



Parker's Motion & Control Technologies

At Parker, we're guided by a relentless drive to help our customers become more productive and achieve higher levels of profitability by engineering the best systems for their requirements. It means looking at customer applications from many angles to find new ways to create value. Whatever the motion and control technology need, Parker has the experience, breadth of product and global reach to consistently deliver. No company knows more about motion and control technology than Parker. For further info call 00800 27 27 5374



Aerospace

Key Markets

Aftermarket services
Commercial transports
Engines
General & business aviation
Helicopters
Launch vehicles
Military aircraft
Missiles
Power generation
Regional transports
Unmanned aerial vehicles

Key Products

Control systems & actuation products
Engine systems & components
Fluid conveyance systems & components
Fluid metering, delivery & atomization devices
Fuel systems & components
Fuel tank inerting systems
Hydraulic systems & components
Thermal management
Wheels & brakes



Climate Control

Key Markets

Agriculture
Air conditioning
Construction Machinery
Food & beverage
Industrial machinery
Life sciences
Oil & gas
Precision cooling
Process
Refrigeration
Transportation

Key Products

Accumulators
Advanced actuators
CO₂ controls
Electronic controllers
Filter driers
Hand shut-off valves
Heat exchangers
Hose & fittings
Pressure regulating valves
Refrigerant distributors
Safety relief valves
Smart pumps
Solenoid valves
Thermostatic expansion valves



Electromechanical

Key Markets

Aerospace
Factory automation
Life science & medical
Machine tools
Packaging machinery
Paper machinery
Oil & gas
Primary metals
Semiconductor & electronics
Textile
Wire & cable

Key Products

AC/DC drives & systems
Electric actuators, gantry robots & slides
Electrohydraulic actuation systems
Electromechanical actuation systems
Human machine interface
Linear motors
Stepper motors, servo motors, drives & controls
Structural extrusions



Filtration

Key Markets

Aerospace
Food & beverage
Industrial plant & equipment
Life sciences
Marine
Mobile equipment
Oil & gas
Power generation & renewable energy
Process
Transportation
Water Purification

Key Products

Analytical gas generators
Compressed air filters & dryers
Engine air, coolant, fuel & oil filtration systems
Fluid condition monitoring systems
Hydraulic & lubrication filters
Hydrogen, nitrogen & zero air generators
Instrumentation filters
Membrane & fiber filters
Microfiltration
Sterile air filtration
Water desalination & purification filters & systems



Fluid & Gas Handling

Key Markets

Aerial lift
Agriculture
Bulk chemical handling
Construction machinery
Food & beverage
Fuel & gas delivery
Industrial machinery
Life sciences
Marine
Mining
Mobile
Oil & gas
Renewable energy
Transportation

Key Products

Check valves
Connectors for low pressure fluid conveyance
Deep sea umbilicals
Diagnostic equipment
Hose couplings
Industrial hose
Mooring systems & power cables
PTFE hose & tubing
Quick couplings
Rubber & thermoplastic hose
Tube fittings & adapters
Tubing & plastic fittings



Hydraulics

Key Markets

Aerial lift
Agriculture
Alternative energy
Construction machinery
Forestry
Industrial machinery
Machine tools
Marine
Material handling
Mining
Oil & gas
Power generation
Refuse vehicles
Renewable energy
Truck hydraulics
Turf equipment

Key Products

Accumulators
Cartridge valves
Electrohydraulic actuators
Human machine interfaces
Hybrid drives
Hydraulic cylinders
Hydraulic motors & pumps
Hydraulic systems
Hydraulic valves & controls
Hydrostatic steering
Integrated hydraulic circuits
Power take-offs
Power units
Rotary actuators
Sensors



Pneumatics

Key Markets

Aerospace
Conveyor & material handling
Factory automation
Life science & medical
Machine tools
Packaging machinery
Transportation & automotive

Key Products

Air preparation
Brass fittings & valves
Manifolds
Pneumatic accessories
Pneumatic actuators & grippers
Pneumatic valves & controls
Quick disconnects
Rotary actuators
Rubber & thermoplastic hose & couplings
Structural extrusions
Thermoplastic tubing & fittings
Vacuum generators, cups & sensors



Process Control

Key Markets

Alternative fuels
Biopharmaceuticals
Chemical & refining
Food & beverage
Marine & shipbuilding
Medical & dental
Microelectronics
Nuclear Power
Offshore oil exploration
Oil & gas
Pharmaceuticals
Power generation
Pulp & paper
Steel
Water/wastewater

Key Products

Analytical instruments
Analytical sample conditioning products & systems
Chemical injection fittings & valves
Fluoropolymer chemical delivery fittings, valves & pumps
High purity gas delivery fittings, valves, regulators & digital flow controllers
Industrial mass flow meters/controllers
Permanent no-weld tube fittings
Precision industrial regulators & flow controllers
Process control double block & bleeds
Process control fittings, valves, regulators & manifold valves



Sealing & Shielding

Key Markets

Aerospace
Chemical processing
Consumer
Fluid power
General industrial
Information technology
Life sciences
Microelectronics
Military
Oil & gas
Power generation
Renewable energy
Telecommunications
Transportation

Key Products

Dynamic seals
Elastomeric o-rings
Electro-medical instrument design & assembly
EMI shielding
Extruded & precision-cut, fabricated elastomeric seals
High temperature metal seals
Homogeneous & inserted elastomeric shapes
Medical device fabrication & assembly
Metal & plastic retained composite seals
Shielded optical windows
Silicone tubing & extrusions
Thermal management
Vibration dampening

Parker Worldwide

Europe, Middle East, Africa

AE – United Arab Emirates, Dubai
Tel: +971 4 8127100
parker.me@parker.com

AT – Austria, Wiener Neustadt
Tel: +43 (0)2622 23501-0
parker.austria@parker.com

AT – Eastern Europe, Wiener Neustadt
Tel: +43 (0)2622 23501 900
parker.easteurope@parker.com

AZ – Azerbaijan, Baku
Tel: +994 50 2233 458
parker.azerbaijan@parker.com

BE/LU – Belgium, Nivelles
Tel: +32 (0)67 280 900
parker.belgium@parker.com

BG – Bulgaria, Sofia
Tel: +359 2 980 1344
parker.bulgaria@parker.com

BY – Belarus, Minsk
Tel: +375 17 209 9399
parker.belarus@parker.com

CH – Switzerland, Etoy
Tel: +41 (0)21 821 87 00
parker.switzerland@parker.com

CZ – Czech Republic, Klecany
Tel: +420 284 083 111
parker.czechrepublic@parker.com

DE – Germany, Kaarst
Tel: +49 (0)2131 4016 0
parker.germany@parker.com

DK – Denmark, Ballerup
Tel: +45 43 56 04 00
parker.denmark@parker.com

ES – Spain, Madrid
Tel: +34 902 330 001
parker.spain@parker.com

FI – Finland, Vantaa
Tel: +358 (0)20 753 2500
parker.finland@parker.com

FR – France, Contamine s/Arve
Tel: +33 (0)4 50 25 80 25
parker.france@parker.com

GR – Greece, Athens
Tel: +30 210 933 6450
parker.greece@parker.com

HU – Hungary, Budaörs
Tel: +36 23 885 470
parker.hungary@parker.com

IE – Ireland, Dublin
Tel: +353 (0)1 466 6370
parker.ireland@parker.com

IT – Italy, Corsico (MI)
Tel: +39 02 45 19 21
parker.italy@parker.com

KZ – Kazakhstan, Almaty
Tel: +7 7273 561 000
parker.easteurope@parker.com

NL – The Netherlands, Oldenzaal
Tel: +31 (0)541 585 000
parker.nl@parker.com

NO – Norway, Asker
Tel: +47 66 75 34 00
parker.norway@parker.com

PL – Poland, Warsaw
Tel: +48 (0)22 573 24 00
parker.poland@parker.com

PT – Portugal, Leca da Palmeira
Tel: +351 22 999 7360
parker.portugal@parker.com

RO – Romania, Bucharest
Tel: +40 21 252 1382
parker.romania@parker.com

RU – Russia, Moscow
Tel: +7 495 645-2156
parker.russia@parker.com

SE – Sweden, Spånga
Tel: +46 (0)8 59 79 50 00
parker.sweden@parker.com

SK – Slovakia, Banská Bystrica
Tel: +421 484 162 252
parker.slovakia@parker.com

SL – Slovenia, Novo Mesto
Tel: +386 7 337 6650
parker.slovenia@parker.com

TR – Turkey, Istanbul
Tel: +90 216 4997081
parker.turkey@parker.com

UA – Ukraine, Kiev
Tel +380 44 494 2731
parker.ukraine@parker.com

UK – United Kingdom, Warwick
Tel: +44 (0)1926 317 878
parker.uk@parker.com

ZA – South Africa, Kempton Park
Tel: +27 (0)11 961 0700
parker.southafrica@parker.com

North America

CA – Canada, Milton, Ontario
Tel: +1 905 693 3000

US – USA, Cleveland
Tel: +1 216 896 3000

Asia Pacific

AU – Australia, Castle Hill
Tel: +61 (0)2-9634 7777

CN – China, Shanghai
Tel: +86 21 2899 5000

HK – Hong Kong
Tel: +852 2428 8008

IN – India, Mumbai
Tel: +91 22 6513 7081-85

JP – Japan, Tokyo
Tel: +81 (0)3 6408 3901

KR – South Korea, Seoul
Tel: +82 2 559 0400

MY – Malaysia, Shah Alam
Tel: +60 3 7849 0800

NZ – New Zealand, Mt Wellington
Tel: +64 9 574 1744

SG – Singapore
Tel: +65 6887 6300

TH – Thailand, Bangkok
Tel: +662 186 7000-99

TW – Taiwan, Taipei
Tel: +886 2 2298 8987

South America

AR – Argentina, Buenos Aires
Tel: +54 3327 44 4129

BR – Brazil, Sao Jose dos Campos
Tel: +55 800 727 5374

CL – Chile, Santiago
Tel: +56 2 623 1216

MX – Mexico, Toluca
Tel: +52 72 2275 4200

We reserve the right to make technical changes. The data correspond to the technical state at the time of printing.
© 2013 Parker Hannifin Corporation.
All rights reserved.

192-510012N7

June 2013



EMEA Product Information Centre

Free phone: 00 800 27 27 5374

(from AT, BE, CH, CZ, DE, DK, EE, ES, FI, FR, IE, IL, IS, IT, LU, MT, NL, NO, PL, PT, RU, SE, SK, UK, ZA)

US Product Information Centre

Toll-free number: 1-800-27 27 537

www.parker.com

Your local authorized Parker distributor