

aerospace
climate control
electromechanical
filtration
fluid & gas handling
hydraulics
pneumatics
process control
sealing & shielding

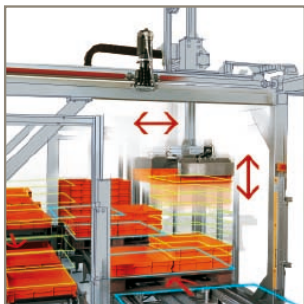

HPLA Linear Actuators

Toothed Belt / Rack-and-Pinion Drive



ENGINEERING YOUR SUCCESS.

Contents

Parker Linear Actuators	10
HPLA Linear Actuator	12
Product Description.....	12
Product Design	13
Technical Data	14
Load Bearing Capacity of Toothed Belt and Carriage.....	15
Drive Options.....	15
Transmissible Forces and Torques.....	16
Additional Mass Moment of Inertia due to Payload and Toothed Belt Mass	19
Definition of Stroke, Usable Stroke and Safety Travel	20
Dimensions.....	21
HPLA080 with Toothed Belt Drive.....	21
HPLA120 with Toothed Belt Drive.....	21
HPLA180 with Toothed Belt Drive.....	22
HPLAZ180 with Rack-and-Pinion Drive	22
HPLA Idler Unit	23
Carriage with Bar	24
Possible Drive Combinations.....	26
Accessories	39
Assembly Angle Plate	39
T-Nuts and Bolts.....	40
Toe Clamp	41
External Stop Buffer	42
Longitudinal Flanges	42
Intermediate Shaft Bearing for Double Axes	43
Position Switch	44
Linear Encoder	48
Cable Carrier	49
Other Accessories / Software	53
Order Code	54

Parker Hannifin

The global leader in motion and control technologies and systems

Global Partnerships Global Support

Parker is committed to helping make our customers more productive and more profitable through our global offering of motion and control products and systems. In an increasingly competitive global economy, we seek to develop customer relationships as technology partnerships. Working closely with our customers, we can ensure the best selection of technologies to suit the needs of our customers' applications.

Electromechanical Technologies for High Dynamic Performance and Precision Motion

Parker electromechanical technologies form an important part of Parker's global motion and control offering. Electromechanical systems combine high performance speed and position control with the flexibility to adapt the systems to the rapidly changing needs of the industries we serve.

aerospace
climate control
electromechanical
filtration
fluid & gas handling
hydraulics
pneumatics
process control
sealing & shielding

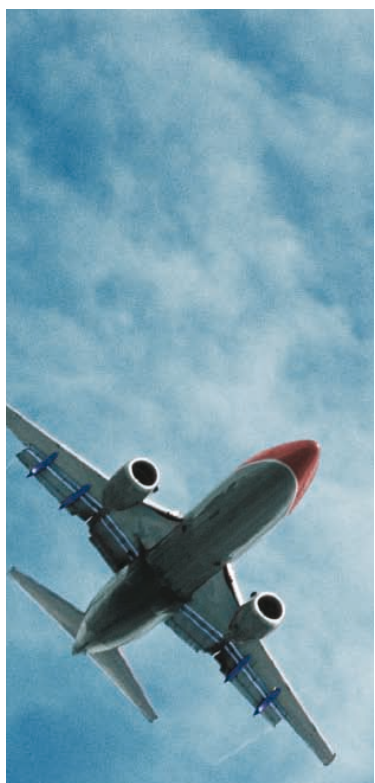

Parker Hannifin Corporation

With annual sales exceeding \$12 billion, Parker Hannifin is the world's leading diversified manufacturer of motion and control technologies and systems, providing precision-engineered solutions for a wide variety of commercial, mobile, industrial and aerospace markets. The company employs more than 62,000 people in 48 countries

around the world. Parker has increased its annual dividends paid to shareholders for 52 consecutive years, among the top five longest-running dividend-increase records in the S&P 500 index. For more information, visit the company's web site at www.parker.com, or its investor information site at www.phstock.com.

Electromechanical Automation

Global products with local manufacturing and support

Global Product Design

Parker Hannifin has more than 40 years' experience in the design and manufacturing of drives, controls, motors and mechanical products. With dedicated global product development teams, Parker draws on industry-leading technological leadership and experience from engineering teams in Europe, North America and Asia.

Local Application Expertise

Parker has local engineering resources committed to adapting and applying our current products and technologies to best fit our customers' needs. Parker's engineering resources also extend to the development and manufacture of complete systems for continuous process and motion control applications.

Manufacturing to Meet Our Customers' Needs

Parker is committed to meeting the increasing service demands that our customers require to succeed in the global industrial market. Parker's manufacturing teams seek continuous improvement through the implementation of lean manufacturing methods throughout the process. We measure ourselves on meeting our customers' expectations of quality and delivery, not just our own. In order to meet these expectations, Parker operates and continues to invest in our manufacturing facilities in Europe, North America and Asia. This allows us to minimize transportation time and cost and to be able to respond more quickly to customer needs.

Worldwide Electromechanical Automation Manufacturing Locations

Europe

Littlehampton, United Kingdom
Dijon, France
Offenburg, Germany
Milan, Italy

Asia

Shanghai, China
Chennai, India

North America

Charlotte, North Carolina
Rohnert Park, California
Irwin, Pennsylvania
Wadsworth, Ohio
Port Washington, New York
New Ulm, Minnesota



Offenburg, Germany



Littlehampton, UK

Local Manufacturing and Support in Europe

Parker provides sales assistance and local technical support through a group of dedicated sales teams and a network of authorized technical

distributors throughout Europe. For contact information, please refer to the Sales Offices on the back cover of this document or visit www.parker.com.

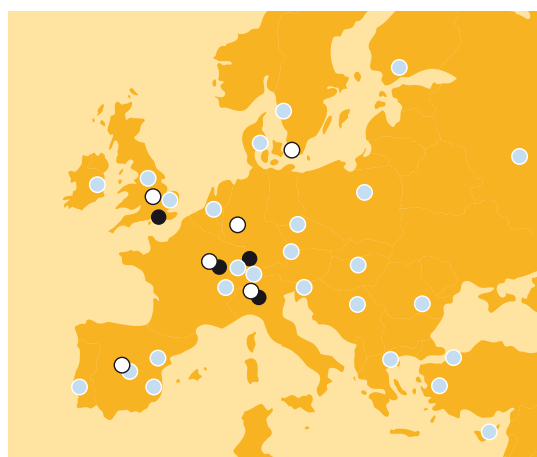

● Manufacturing ○ Parker Sales Offices ● Distributors



Milan, Italy



Dijon, France

Solutions to Improve Productivity, Increase Flexibility and Save Energy

Process Productivity and Reliability

Parker brings together the technology and experience required for continuous process applications across many industries. AC and DC variable speed drive products combined with application-specific function block-based configuration software ensure precise speed control and reliable performance. Parker combines more than 30 years of application experience with a global sales and support network that help you increase your machine availability.

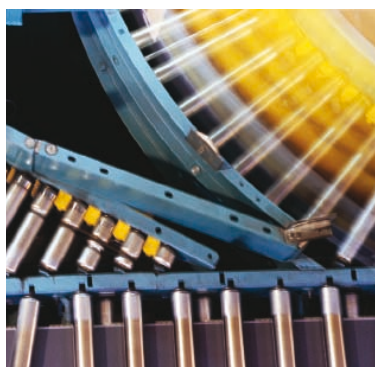

	AC Drives	DC Drives	Direct Drive Motors	Servo Drives and Motors
Converting machinery				
Folding, gluing, stitching and collating	✓	✓		✓
Coating, laminating and foil stamping	✓	✓	✓	✓
Slitting, cutting and rewinding	✓	✓	✓	✓
Plastics processing machinery				
Plastic extrusion	✓		✓	
Injection moulding	✓		✓	✓
Thermal forming	✓		✓	✓
Wire and cable				
Wire and cable manufacturing	✓	✓		✓
Winding/unwinding	✓	✓	✓	
Extrusion for wire and cable	✓	✓	✓	
Printing Machinery				
Web/sheetfed offset	✓		✓	✓
Flexo printing	✓		✓	✓
Gravure printing	✓		✓	✓
Shaftless printing	✓		✓	✓
Other industries				
Paper machinery	✓		✓	
Sugar processing	✓	✓		
Steel production	✓	✓	✓	
Construction materials	✓	✓		
Automotive test rigs	✓	✓	✓	

Energy Efficiency and Clean Power

Parker has developed the technology to maximize the efficient use of energy in industrial, mobile and infrastructure environments.

Hybrid Vehicle Technology

Parker has adapted its electric drive technologies for use in hybrid electric vehicles, including utility vehicles and passenger vehicles. Examples include inverters and motor drives, as well as electric drive motors.

Energy Savings for Pumps, Fans and Compressors

Parker has the drive technology to help you make significant energy savings in the operation of pumps, fans and compressors in both industrial and infrastructure applications, including:

- Commercial refrigeration
- Water and wastewater treatment
- Building automation
- Industrial processes
- Hydraulic systems



Power Generation and Conversion

Using proven inverter technology, Parker has developed numerous solutions for the conversion of energy for commercial use from a variety of sources, including wind, wave and energy storage devices.

Motion Control Systems for Total Production Flexibility

Parker's electromechanical automation customers enjoy total production flexibility in their general and precision motion control applications. Complete packaged linear positioning systems, coupled to servo and stepper drives and controls, enable our customers to develop a complete motion solution with one partner. Parker provides the products for a wide range of motion needs- power, speed, travel, force- with easy to use controls designed to work on multiple control and communication platforms. Additionally, Parker's products can be easily customized to suit specific applications.



	Mechanical Actuators	Motors and Gearheads	Drives	Controls	HMI
Assembly machinery					
Pick and place	✓	✓	✓	✓	✓
Lifting	✓	✓	✓	✓	
Transfer machinery	✓	✓	✓	✓	✓
Automotive assembly					
Resistance welding	✓	✓	✓	✓	
Painting applications	✓	✓	✓	✓	✓
Transfer machinery	✓	✓	✓	✓	✓
Packaging machinery					
Primary, secondary, tertiary	✓	✓	✓	✓	✓
Handling machinery	✓	✓	✓	✓	✓
Food processing machinery					
Processing machinery	✓	✓	✓	✓	
Packaging machinery	✓	✓	✓	✓	
Handling machinery	✓	✓	✓	✓	✓
Material handling systems					
Transfer systems	✓	✓	✓	✓	✓
Pick and place systems	✓	✓	✓	✓	✓
Metal forming machinery					
Presses	✓	✓	✓	✓	✓
Tube bending	✓	✓	✓	✓	✓
Handling applications	✓	✓	✓	✓	✓
Machine tools					
Spindles		✓	✓		
Ancillary axes		✓	✓		
Semiconductor machinery					
Front end processes	✓	✓	✓	✓	✓
Inspection machinery	✓	✓	✓	✓	✓
Packaging machinery	✓	✓	✓	✓	✓
Lithography	✓	✓	✓	✓	
Medical devices					
Device manufacturing	✓	✓	✓	✓	✓
Product packaging and dispensing	✓	✓	✓	✓	✓
Scanning equipment	✓	✓	✓		
Pumps and analyzers		✓	✓		
Entertainment					
Theatre and studio automation	✓	✓	✓	✓	
Simulation and amusement rides	✓	✓	✓		

Complete Range of Solutions

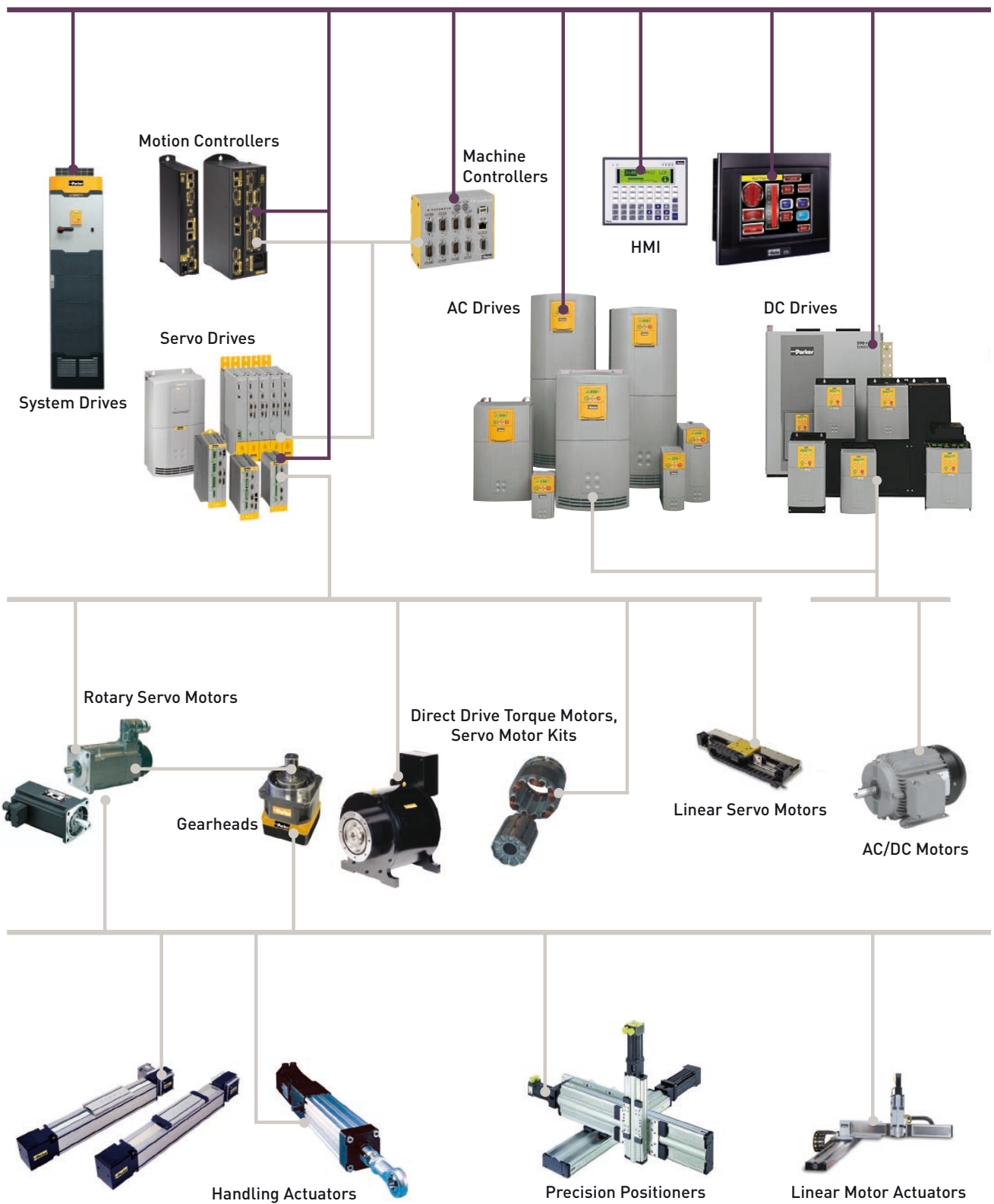

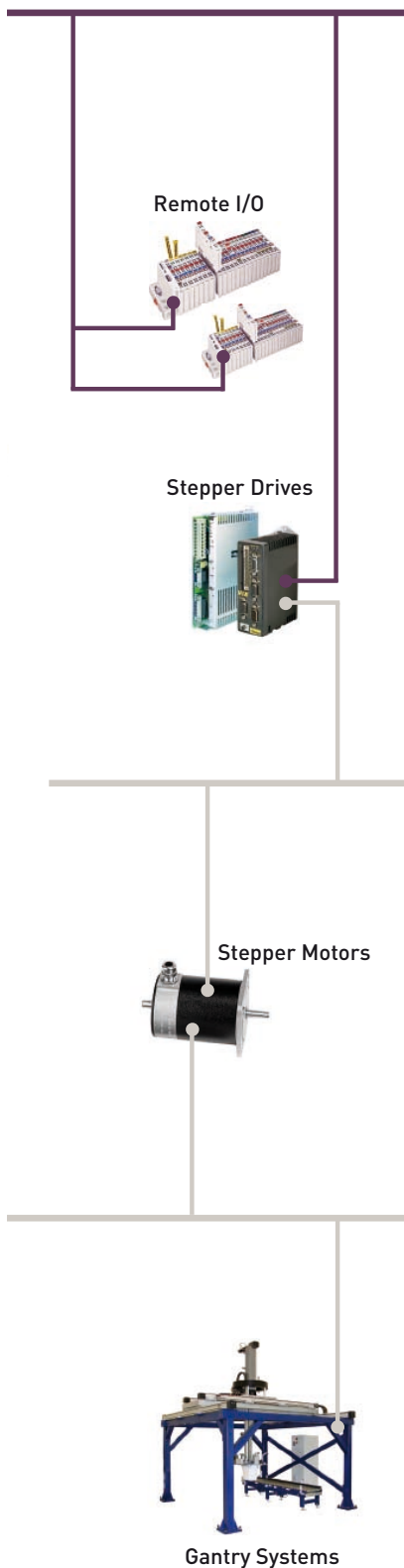

Value Added Services

In addition to providing products and systems, Parker also provides a number of value added services to our customers:

- Programming and commissioning services
- Power quality and energy surveys
- 24-hour support and service
- Product repairs
- Product training

Customization

Many automation applications cannot be solved with off the shelf products. Parker's products are designed to be versatile as well as easy to configure for the majority of industrial and process applications. Some customers require solutions that can't be found in a catalogue, and Parker has the resources and expertise available to provide customized solutions:

- Custom motor designs
- Customized mechanical positioning systems
- Customized control functionality
- Customized communication solutions



System Solutions

Parker offers system design and manufacturing in two main categories:

Drive Systems

Complete AC and DC drive systems across a wide power range, from less than 1 kW to more than 1 MW. Systems typically include electrical enclosure, ancillary electronic equipment and full documentation. Commissioning and support services are standard.

Mechanical Systems

Parker has more than 20 years of experience in providing a variety of multiple axis mechanical positioning systems, complete with motors, drives and controls. Typical applications include material transfer and pick and place gantry systems. Additionally, Parker designs and builds custom precision positioning systems, integrating precision bearing, feedback and drive systems, including Parker's range of linear servo motors. Each system ships complete with motors, drives and controls, and can include the programming and commissioning.

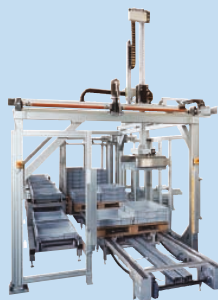

Parker Linear Actuators

Benefits of Parker Linear Actuators

A part of Parker's mechanical components comprises linear actuators, vertical actuators, telescopic actuators and screw actuators, which are all based on an aluminum profile. Depending on the load, several types with different profile cross-sections are available. The carriages run either on sliding bearings, on plastic-

sheathed rollers or steel rollers. As drive options, ballscrew drives, conventional toothed belt drives or a combination of toothed belt and rack-and-pinion-drive are available.

Toothed belt drive with rollers

HPLA, HLE Linear Actuators
www.parker-eme.com/hpla
www.parker-eme.com/hle

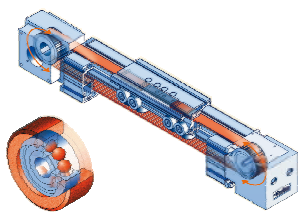

For high dynamics at small to medium stroke lengths. Plastic sheathed rollers, optionally steel rollers, for high payloads.

Toothed belt drive with sliding bearing

LCB Linear Actuator
www.parker-eme.com/cb

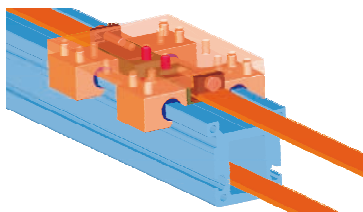

Clean operation without lubricants.

Rack-and-pinion drive

HPLAZ, HLEZ Linear Actuator
www.parker-eme.com/hpla
www.parker-eme.com/hle

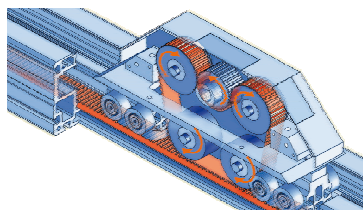

A short toothed belt runs on a tooth rack without lubrication. This ensures a consistent and high rigidity even with long strokes.

Linear motor principle

PowerRod, BLMA Linear Actuators
www.parker-eme.com/powerrod
www.parker-eme.com/blma

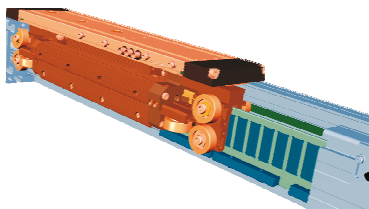

For highest dynamics and high precision.

Drive for high forces when moving in axial direction

ET Screw Actuator
www.parker-eme.com/et

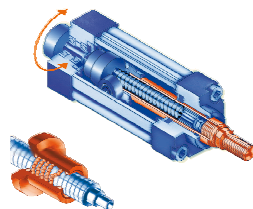

Ballscrew in the ET electro thrust cylinder.

Omega drive for vertical movements

HZR Z-Axis
www.parker-eme.com/hzr

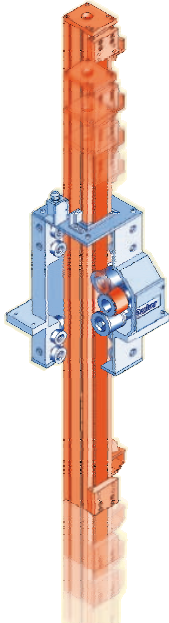

Drive station fixed, toothed belt and profile movable together

Telescopic drive for vertical movements

HTR telescopic actuator
www.parker-eme.com/htr

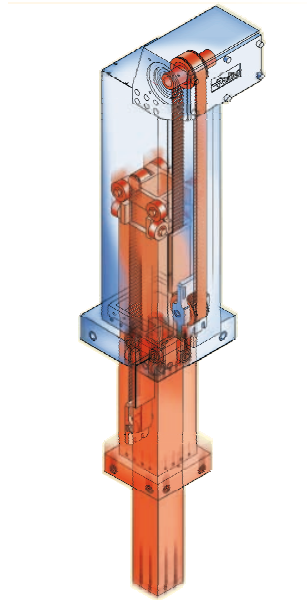

Three-stage telescopic actuator featuring an extremely low height.

Accessories

A wide range of Parker accessories simplifies the integration.

Motors and controllers

The right gear-servomotor will, in combination with the optimal Parker servo amplifier, solve any positioning task.

All from one source

Our modular system allows a flexible, cost-efficient design of complex systems and plants. Please contact your local sales office for more information.

HPLA Linear Actuator

HPLA Dynamic High-Performance Linear Actuators

Product Description

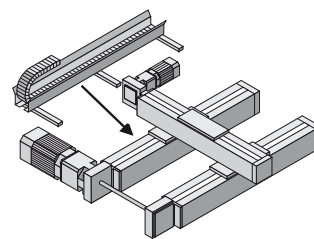
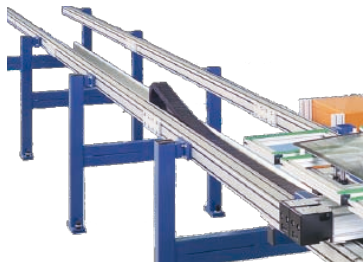
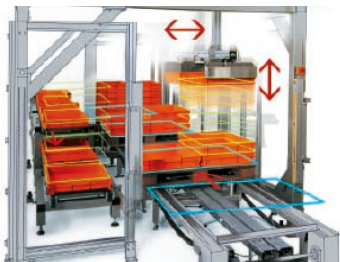

Typical areas of application...

within the scope of innovative and cost-effective machine and system design:

- **Handling technology** e.g. palletizing, material feed and removal
- **Textile machine construction:** e.g. cross-, length cutting and stacking, quilting, seaming
- **Process engineering:** e.g. varnishing, coating, gluing, engraving
- **Stock technology:** e.g. commissioning, stock keeping
- **Construction technology** e.g. encasing, inserting steel reinforcements into concrete
- **Clean room technology:** e.g. wafer transport, wafer coating
- **Machine tool manufacturing:** e.g. charging of the work pieces, changing the tools
- **Testing technology:** e.g. guiding of ultrasonic sensors

The highly dynamic linear actuator...

for guiding, moving and positioning, even over long travels, we offer:

- **Long strokes:**
- up to 50 m with rack-and-pinion drive (HPLA180)
- up to 20 m with toothed belt drive
- **High speeds** in practice up to 5 m/s
- **High payloads** up to 1600 kg
- **Nominal drive torque** up to 244 Nm
- **Nominal thrust force** up to 5500 N
- **Repeatability** up to ± 0.05 mm
- **High mechanical efficiency**
- With rack-and-pinion drive, **several individual carriages** can run in one actuator
- **Three frame sizes:** HPLA080, HPLA120 and HPLA180 - allow the combination of actuators, (including other types of linear actuators), to create complete handling systems
- **FEM optimized extruded profile:** For highest resistance to flexing and torsion at minimized weight
- **Simple, non-critical installation and start up**

The modular concept ...

provides the ideal solution for every application:

The modular drive system:

- either toothed belt:
 - high dynamic performance
 - extremely low maintenance
- or rack-and-pinion (HPLAZ180):
 - high dynamic performance
 - high precision and rigidity

The modular guiding system:

- either plastic roller guiding:
 - clean operation, as the travel surface is free of lubricants
 - low maintenance
- or steel roller guiding on an integrated steel strip:
 - high load bearing capacity
 - high stiffness

Several adaption options for the most different applications:

- Steel strip cover
- stainless VA version as a prerequisite for use in clean-room applications or in the food industry
- integrated length measuring system for highest precision (on request)

Product Design

(1) The profile

The extruded aluminum profile is optimized for highest stiffness (torsion and deflection) at the lowest possible mass by means of the FEM method.

The modular concept permits to use the same profile for all HPLA versions:

- Drive version with toothed belt
- Drive version with toothed rack
- Guiding with plastic rollers on anodized aluminum
- Guiding with steel rollers on a steel strip integrated into the profile.

(2) The carriage

The aluminum carriage profile was also optimized by means of the FEM method. The rolling-contact plastic or steel rollers with lifetime lubrication are aligned backlash-free in all directions via eccentric. The carriage is available in 2 sizes as a standard carriage with 12 rollers or as an extended carriage with 24 rollers.

(3) The tensioning station

Easy-to-access, simple maintenance and mounting tensioning station for setting the required pre-tension of the toothed belt and its alignment (parallelism of the toothed pulleys).

(4) The drive station

The HPLA features several drive options. Everything is possible from the pulley directly on the gear shaft via a hollow shaft with bearing directly in the housing to the version with drive shaft on the left, on the right or on both sides.

(5) The toothed belt

The practically backlash-free toothed belt reinforced by steel tension cords guarantees high travel speeds and repeatabilities.

(6) Toothed belt clamping

The toothed belt fixing bracket and the wide area toothed belt clamp ensure a safe connection of toothed belt and carriage.

The clamping system allows the toothed belt to be changed without removing the load attachment plate. This means that it is in most cases not necessary to remove the mounted components.

(7) The load attachment plate

Many possibilities to mount parts by integrated longitudinal grooves at the upper side of the plate. In connection with the clamping profiles, this allows an easy integration into multi-axis systems. Simple and variable fixing of tripping plate by means of longitudinal grooves on the sides of the profile.

The unit height and the fixing points remain unchanged even if a steel strip cover is mounted in retrospective.

HPLA with Toothed Belt Drive

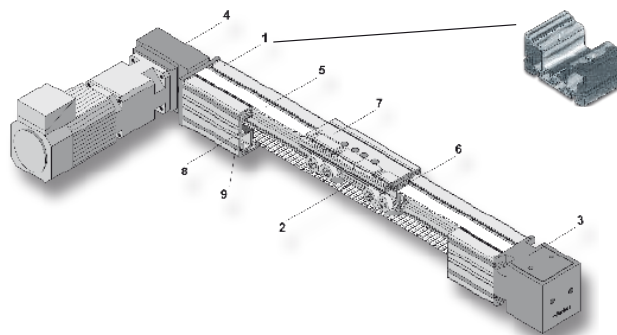

HPLA with Rack-and-Pinion Drive

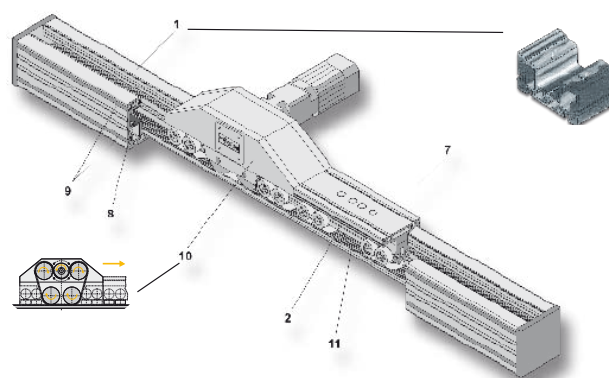

(8) The steel strips

In the steel roller version, 6 steel strips are inserted into the profile.

(9) Mounting grooves

The profile is available in cross sections 80 x 80 (HPLA080), 120 x 120 (HPLA120), 180 x 180 (HPLA180). Mounting grooves on both sides and on the underside of the profile allow to mount additional mechanic components or to connect several linear actuators with the aid of nuts according to DIN 508. These grooves are also suitable as cable ducts if equipped with the available cover profile (9).

(10) The drive module

The rack-and-pinion drive offers all advantages of a toothed belt drive, does however eliminate the typical disadvantages. The consistently short toothed belt, which is independent of the travel stroke, reduces belt stretch to a minimum. The combination of plastic toothed belt with an aluminum rack is a safe and clean drive which does not require lubrication.

(11) The tooth rack

The tooth rack is well protected within the profile. Therefore this drive variant also offers the possibility to use a steel strip cover.

Advantages of the rack-and-pinion drive:

- High, consistent stiffness independent of the stroke length or position
- Very long strokes can be realized
- High precision
- High speeds can be realized
- No lubrication required
- Any fitting position possible

Available Options

- Steel strip cover
- Integrated linear encoder for highest precision (on request)
- Longitudinal flange(s) permit(s) to extend the profile for long strokes
- Stainless version for rough environments or as a prerequisite for use in clean rooms or in the food or pharmaceutical industry

Technical Data

Frame size	HPLA080		HPLA120		HPLA180			
	Drive	Toothed belt		Toothed belt		Toothed belt		Tooth rack
	Guiding rollers	Plastic	Steel	Plastic	Steel	Plastic	Steel	Plastic
	Unit							

Weights and mass moments of inertia

Weight of base unit without stroke

HPLA with standard carriage (S)	[kg]	6.0	6.6	18.6	19.8	49.8	53.4	71.8
- with steel strip cover		6.8	7.5	20.2	21.6	57.2	61.6	78.4
HPLA with extended carriage (E)	[kg]	7.8	8.6	23.5	25.2	67.4	72.6	88.6
- with steel strip cover		8.6	9.5	25.2	27.1	74.8	80.9	95.2
Mass of carriage + load attachment plate (S)	[kg]	1.5	1.6	5.5	5.7	11.4	11.8	9.9
- with steel strip cover		1.7	1.8	5.8	6.0	12.3	12.6	12.5
Mass of carriage + load attachment plate (E)	[kg]	2.4	2.6	8.5	8.9	20.3	21.0	17.2
- with steel strip cover		2.6	2.8	8.8	9.2	21.1	21.8	19.8
Mass of drive module	[kg]	-	-	-	-	-	-	20.0
Additional weight per meter of stroke	[kg/m]	6.0	7.2	13.5	15.4	29.2	33.4	31.4
- with steel strip cover		6.1	7.3	13.7	15.5	29.4	33.6	31.5

Mass moment of inertia with respect to drive shaft ¹⁾

HPLA with standard carriage (S)	[kgmm ²]	1600	1660	13600	14000	66800	69500	64600
- with steel strip cover		1780	1840	14200	14600	72500	74300	69800
HPLA with extended carriage (E)	[kgmm ²]	2360	2470	19100	19800	107400	110700	79300
- with steel strip cover		2540	2650	19700	20400	112100	115400	84500

Travel lengths and speeds

Max. travel speed	[m/s]	5.0						
Max. acceleration	[m/s ²]	10.0						
Max. travel, standard carriage (S/T) ²⁾	[mm]	5610	5590	9560	9530	9440	9400	8880
- with one profile		5540	5520	9470	9440	9240	9200	8680
Max. travel, extended carriage (S/T) ²⁾	[mm]	5460	5440	9360	9330	9140	9100	8580
- with one profile		5390	5370	9270	9240	8940	8900	8380

Overall dimensions and physical data of guiding profile

Cross-section	[mmxmm]	80 x 80	120 x 120	180 x 180
Moment of Inertia I _x ⁴⁾	[10 ⁴ mm ⁴]	139	724	3610
Moment of Inertia I _y ⁴⁾	[10 ⁴ mm ⁴]	165	830	4077
E-modulus (aluminum)	[N/mm ²]	0.72 * 10 ⁵		

Forces, torques and efficiency

Nominal drive torque	[Nm]	26.5	74.2	244	58
Max. drive torque	[Nm]	47.4	131.4	368	58
Max. thrust force (with hollow shaft bearing)*	[N]	1114	2234	5457	-
Repeatability	[mm]	±0.05	±0.05	±0.05	±0.05
- up to 3 m ³⁾		±0.1	±0.1	±0.1	±0.1
- as from 3 m ³⁾					
Efficiency	[%]	95	95	95	80

Toothed pulley and toothed belt data

Travel distance per revolution	[mm/rev]	180	270	420	280
Number of teeth of pulley	-	18	27	21	28
Toothed belt width / pitch	[mm]	25 / 10	32 / 10	56 / 20	42 / 10
Weight of toothed belt	[kg/m]	0.166	0.213	0.550	0.251
Effective radius of the drive pinion (R _A)	[mm]	28.7	43.0	66.8	44.56

*for additional bearings see chapter "Transmissible Forces and Torques" on page 16.

1) Additional mass moment of inertia caused by the payload and belt mass of a toothed belt drive: see on page 19

2) Longitudinal flanges for longer strokes are possible. The following constraints are to be expected with toothed belt driven linear actuators: Maximum permissible load, drive torque, speed, acceleration and repeatability (see page 42). Linear actuators with rack-and-pinion drive feature an infinite travel on the part of the actuator - it depends solely on the energy supply of the drive.

3) At a constant ambient and operating temperature of the actuator. Determined in accordance with ISO 230-2

4) 2. area moment of inertia

→ Technical data; safety factor taken into consideration S=1. Data applies to a temperature range between -10 °C and +40 °C. The technical data apply under normal conditions and only for the individual operating and load mode. In the case of compound loads, it is necessary to verify in accordance with normal physical laws and technical standards whether individual ratings should be reduced. In case of doubt please contact Parker Hannifin.

Load Bearing Capacity of Toothed Belt and Carriage

Operating force F_x transmitted by the toothed belt / pretension

The operating force F_x transmitted by the toothed belt depends on its pretension. If not stated otherwise, the HPLA is furnished with a default pretension. With this default pretension, the HPLA can maximally transmit the thrust force $F_{nominal}$. If a higher thrust force is required, the toothed belt pretension is increased and forces up to F_{max} can be transmitted. If the operating force F_x is higher than the belt pretension, toothed belt spread might be the result.

Life

The lifetime ($s_{nominal}$ / s_{max}) of the drive train (with the exception of the guiding system and, if the pulley is mounted directly on the drive shaft, the gear bearings), depends on the pretension and on the operating force present.

Forces and torques transmitted by the carriage

Forces (F_y/F_z) and torques ($M_x/M_y/M_z$) transferred by the carriage are speed-dependent. The graphs shown in the diagrams only apply to a standard carriage (S or T).

In the case of extended carriages (E or F), all values with the exception of F_x can be doubled if the load is introduced in pairs or is distributed evenly over the entire length of the carriage. The curves show the maximum load-bearing capacity of a carriage in one direction of force or torque. If several loads are applied in different directions, the values specified in the curves must be derated, i.e. the load or speed should be reduced. Please refer to our "DimAxes" software for precise sizing (see page 53 "Other Accessories / Software").

Drive Options

The drive mounting side left (L) or right (R) is defined looking from the tensioning station to the drive station.

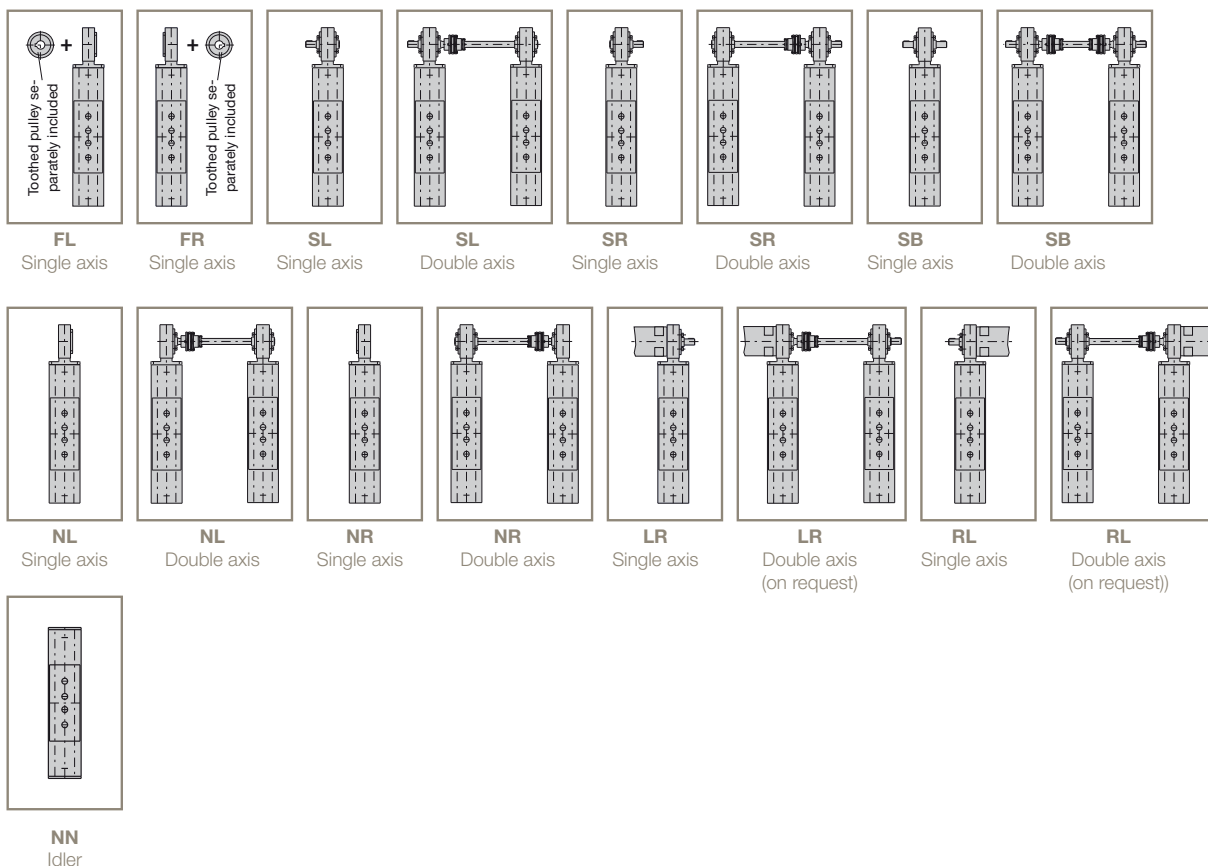

Transmissible Forces and Torques

HPLA080

Please note the explanations in the “Load Bearing Capacity of Toothed Belt and Carriage” chapter on page 15!

Drive Option (=> Chapter “Drive Option“)	Transmissible thrust force (F _x) (for double axes: per belt drive)		Nominal lifetime ¹⁾	
	F _{nominal} [N]	F _{max} [N]	s _{nominal} [km]	s _{max} [km]
Single/double axis				
NL/NR / LR/RL (hollow shaft bearing)	925	1114	81 000	46 000
SL/SR / SB (massive shaft bearing)	925	1114	81 000	46 000
Single axis, pulley directly on the shaft with gearbox				
FL/FR P3 (A)	474	602	81 000	40 000
FL/FR P3V (A)	925	1114	81 000	46 000
FL/FR P4 (B)	557	671	81 000	46 000
FL/FR P4V (B)	925	1114	81 000	46 000
FL/FR PE4 (Q)	500	600	81 000	46 000
FL/FR PE5 (R)	675	900	81 000	46 000
FL/FR PS60 (K)	on request	on request	on request	on request
FL/FR PS90 (M)	on request	on request	on request	on request

1) Basis of the nominal life time calculation for rolling-contact bearings: At least 90 % of all bearings attain or even exceed the nominal lifetime, in part even by far.

Load bearing capacity HPLA080 (F_y and F_z)

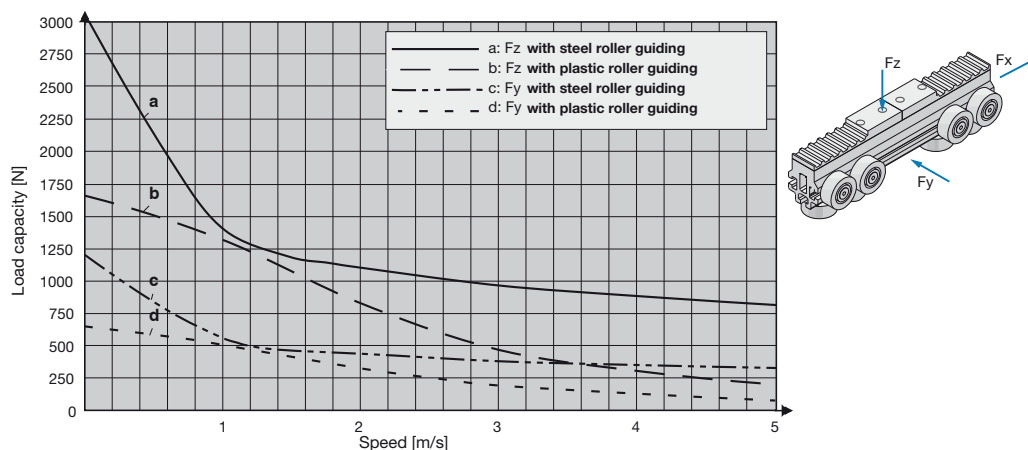

Moment load capacity HPLA080 (M_x, M_y and M_z)

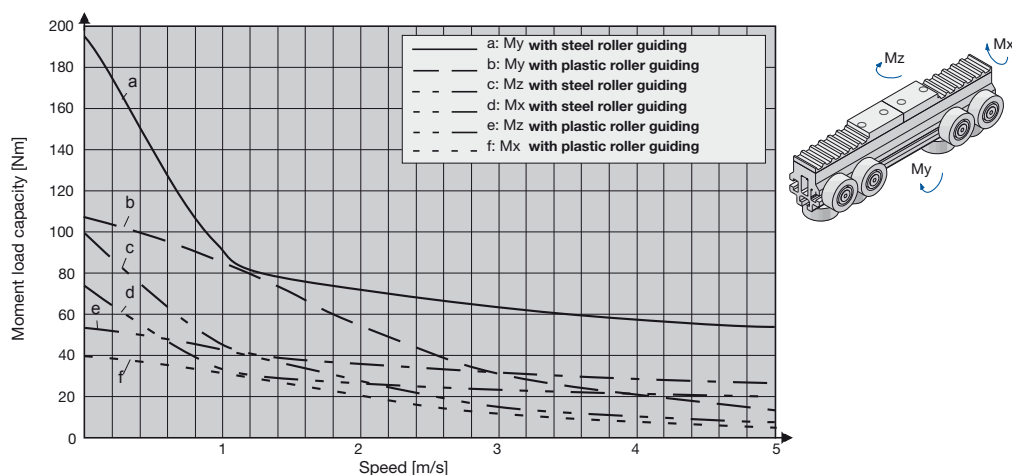

HPLA120

Please note the explanations in the “Load Bearing Capacity of Toothed Belt and Carriage” chapter on page 15!

Drive Option (=> Chapter “Drive Option”)	Transmissible thrust force (Fx) (for double axes: per belt drive)		Nominal lifetime ¹⁾	
	F_nominal [N]	F_max [N]	s_nominal [km]	s_max [km]
Single/double axis				
NL/NR / LR/RL (hollow shaft bearing)	1696	2234	85 000	37 000
SL/SR / SB (massive shaft bearing)	1696	2234	85 000	37 000
Single axis, pulley directly on the shaft with gearbox				
FL/FR P4 (B)	627	905	85 000	28 000
FL/FR P4V (B)	1514	2014	85 000	36 000
FL/FR P5 (C)	1059	1529	85 000	28 000
FL/FR P5V (C)	1696	2234	85 000	37 000
FL/FR PE5 (R)	675	900	85 000	37 000
FL/FR PS90 (M)	on request	on request	on request	on request
FL/FR PS115 (P)	on request	on request	on request	on request

1) Basis of the nominal life time calculation for rolling-contact bearings: At least 90 % of all bearings attain or even exceed the nominal lifetime, in part even by far.

Load bearing capacity HPLA120 (Fy and Fz)

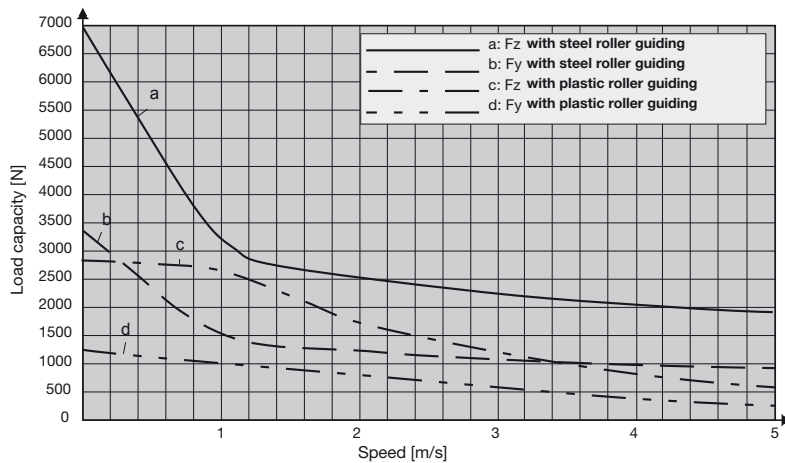

Moment load capacity HPLA120 (Mx, My and Mz)

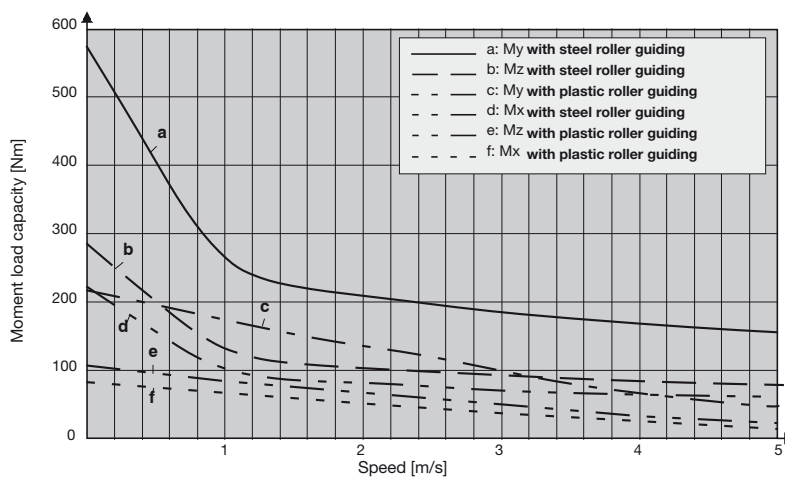

HPLA180 (with toothed belt drive)

Please note the explanations in the “Load Bearing Capacity of Toothed Belt and Carriage” chapter on page 15!

Drive Option (=> Chapter “Drive Option”)	Transmissible thrust force (Fx) (for double axes: per belt drive)		Nominal lifetime ¹⁾	
	F_nominal [N]	F_max [N]	s_nominal [km]	s_max [km]
Single/double axis				
NL/NR / LR/RL (hollow shaft bearing)	4169	5457	100 000	45 000
SL/SR / SB (massive shaft bearing)	3770	3770	136 000	136 000
Single axis, pulley directly on the shaft with gearbox				
FL/FR P5 (C)	1160	1519	100 000	45 000
FL/FR P5V (C)	2513	2513	112 000	112 000
FL/FR P7 (D)	1654	2164	100 000	45 000
FL/FR P7V (D)	3561	4398	100 000	54 000

1) Basis of the nominal life time calculation for rolling-contact bearings: At least 90 % of all bearings attain or even exceed the nominal lifetime, in part even by far.

Load bearing capacity HPLA180 (Fy and Fz)

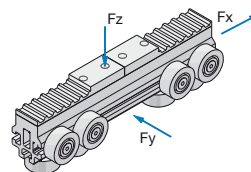
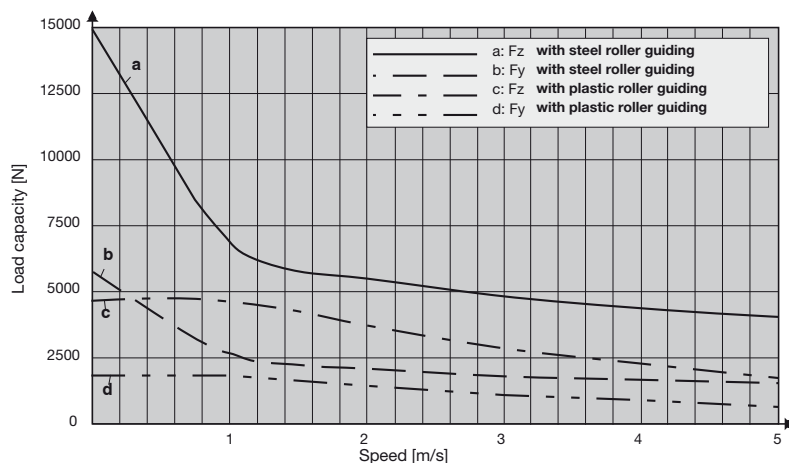

Moment load capacity HPLA180 (Mx, My and Mz)

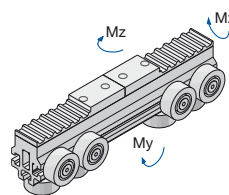
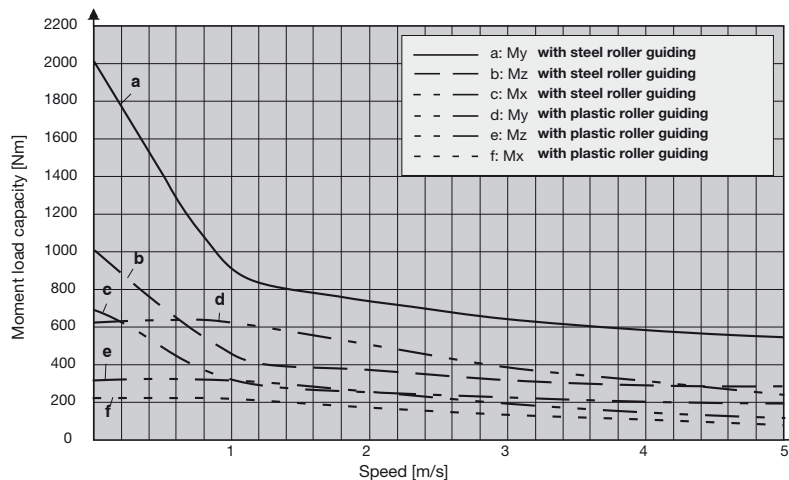

Additional Mass Moment of Inertia due to Payload and Toothed Belt Mass

For linear actuators with toothed belt drive it applies:

$$\begin{aligned} J_Z &= J_{NL} + J_R \\ J_{NL} &= m_{NL} \times R_A^2 \\ J_R &= m_R \times R_A^2 \\ m_R &= L_R \times m_{R1M} \\ L_R &\approx 2 \times \text{Stroke} + L_{ROH} \end{aligned}$$

For linear actuators with rack-and-pinion drive it applies:

$$J_Z = m_{NL} \times R_A^2$$

Motor and gear mass must be added to the payload!

- J_Z = Additional mass moment of inertia [kgmm²]
- J_{NL} = Additional mass moment of inertia caused by the payload [kgmm²]
- J_R = Additional mass moment of inertia caused by the belt mass [kgmm²]
- m_{NL} = Mass of the payload moved by the linear actuator [kg]
- m_R = Mass of the toothed belt [kg]
- m_{R1M} = Mass of the toothed belt per meter of length [kg/m] see page 14 "Technical Data"
- L_R = Length of the toothed belt [m]
- L_{ROH} = Toothed belt length for a linear actuator without stroke (see "Belt length L_{ROH} ")
- R_A = Effective radius of the toothed pulley [mm] see page 14 "Technical Data"

Standard HPLA

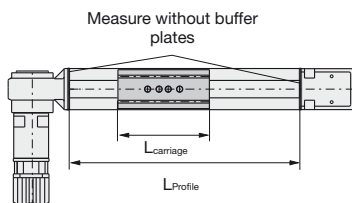

HPLA with steel strip cover

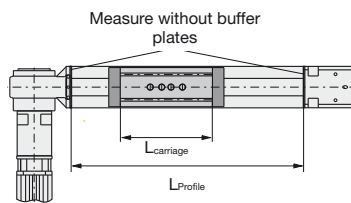

Belt length L_{ROH}

HPLA080: $2 \times L_{Profile} - L_{carriage} + 570$ mm

HPLA120: $2 \times L_{Profile} - L_{carriage} + 740$ mm

HPLA180: $2 \times L_{Profile} - L_{carriage} + 1190$ mm

Definition of Stroke, Usable Stroke and Safety Travel

- Usable stroke:**
 The usable stroke is the distance which you need to move in your application. It is always shorter than the stroke.
- Stroke:**
 The stroke to be indicated in the order code is the maximum possible stroke between the internal end stops. It is composed of

$$\text{Stroke} = \text{Usable stroke} + \text{right safety travel} + \text{left safety travel} + 20 \text{ mm}^{*1}$$

^{1*} We recommend to include an extra travel of approx. 10 mm on each side in order to compensate the switching hysteresis of the limit switches or - depending on the controller - as an addition to the software end limit.

The right and left safety travel is the distance needed in order to decelerate the actuator after activating a limit switch without collision. F_{max} shows the maximum permissible braking force for each axis (at the set maximum permissible belt pretension) and may in no case be exceeded (with a lower belt tension, the values for F_x

must be derated accordingly). If a braking force lower than F_{max} results from the maximum possible braking torque of the drive or of a brake, the safety travel is increased accordingly. Please do also consider the controller reaction times. If needs be, do mount additional buffers.

Calculation of the minimum safety travel required

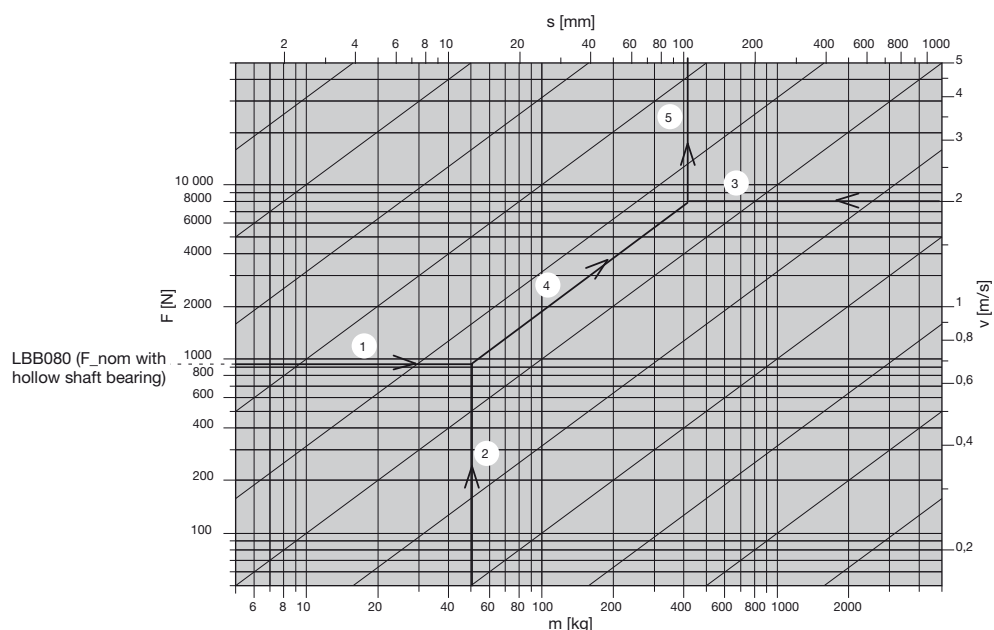

Key:

- m: Payload in kg (for the HPLA with tooth rack, please add the weight of the motor and of the gear to the payload).
- v: Travel speed of the actuator before the braking sequence in m/s.
- F: Braking force of the drive within the emergency stop ramp in N.
- s: The safety travel s in mm resulting from moved mass, speed and braking force.

Example:

The example in the diagram shows the determination of the safety travel for an HPLA080 with a payload of 50 kg (2), braked down from a speed of 2 m/s (3) with the permissible thrust force F_{nominal} (925 N) (1) for this axis. The required braking distance is approx. 110 mm (5) rounded up.

HPLA180 with Toothed Belt Drive (LBB180)

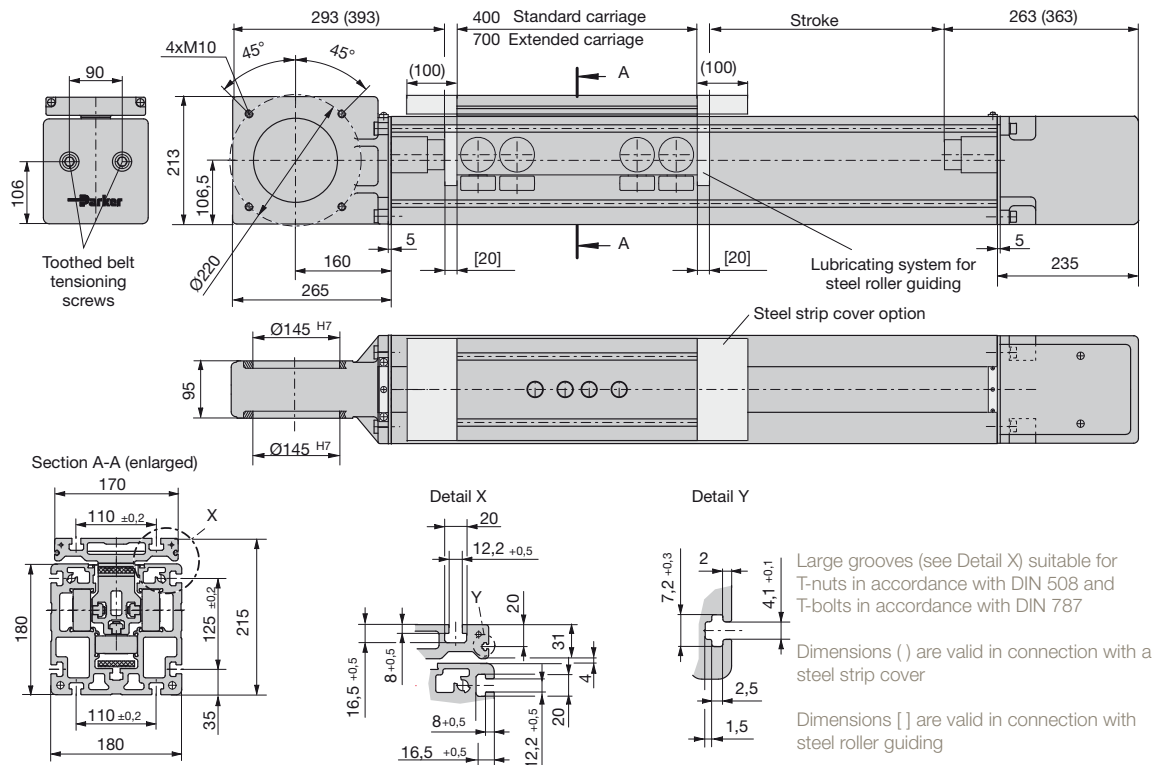

HPLAZ180 with Rack-and-Pinion Drive (LBZ180)

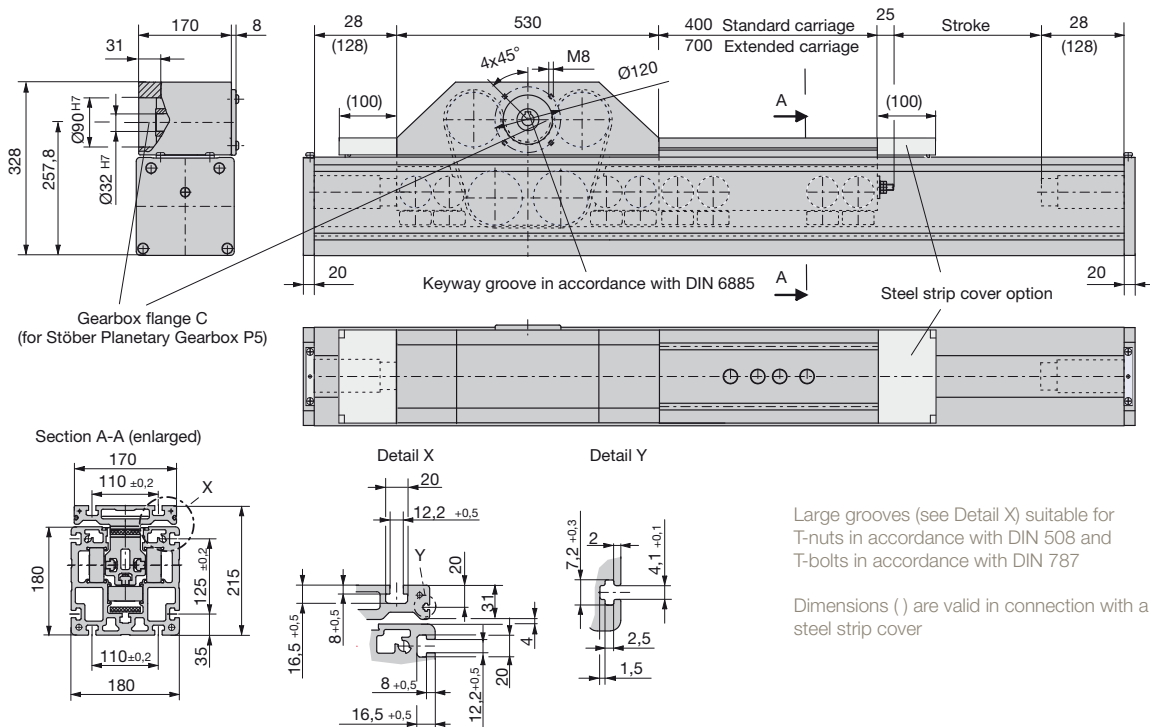

HPLA Idler Unit

The HPLA is also available as a driveless idler unit. In this case, it serves as a mere guiding. The profile cross section and carriage dimensions correspond to those of the driven axes.

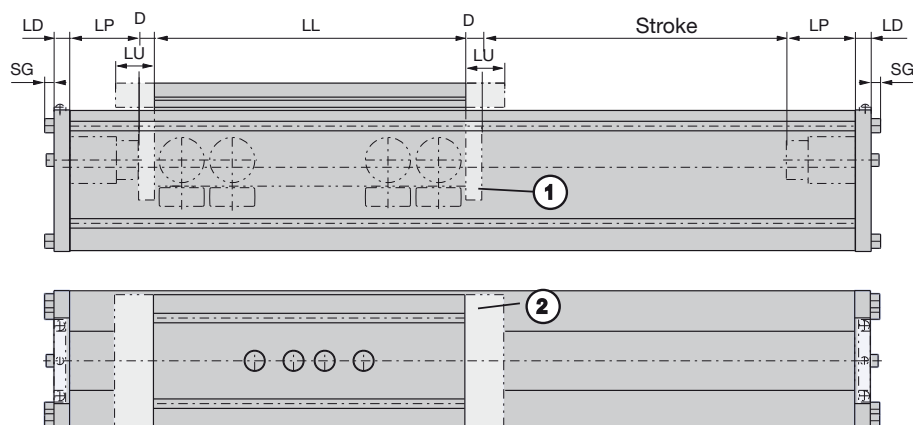

- 1 Lubricating system for steel rollers
- 2 Steel strip cover option

Axis type	Without steel strip cover						With steel strip cover					
	LD	LP	DS	LL	LU	SG	LD	LP	DS	LL	LU	SG
HPLA-LBN080SP	10	20	-	250	-	4	10	55	-	250	40	4
HPLA-LBN080SH			10						-			
HPLA-LBN080EP			-	400					-			
HPLA-LBN080EH			10						-			
HPLA-LBN120SP	15	20	-	300	-	6	15	65	-	300	50	6
HPLA-LBN120SH			13						-			
HPLA-LBN120EP			-	500					-			
HPLA-LBN120EH			13						-			
HPLA-LBN180SP	20	28	-	400	-	12	20	128	-	400	100	12
HPLA-LBN180SH			20						-			
HPLA-LBN180EP			-	700					-			
HPLA-LBN180EH			20						-			

Carriage with Bar

Carriage T/F without load attachment plate; thread drawings for mounting the load

For an HPLA without load attachment plate, a bar is required as a replacement for the belt clamping. threads in the carriage are accessible through bores in the strip. In order to attach your own loads, the

HPLA080 / HPLA120

Standard carriage with bar (T)

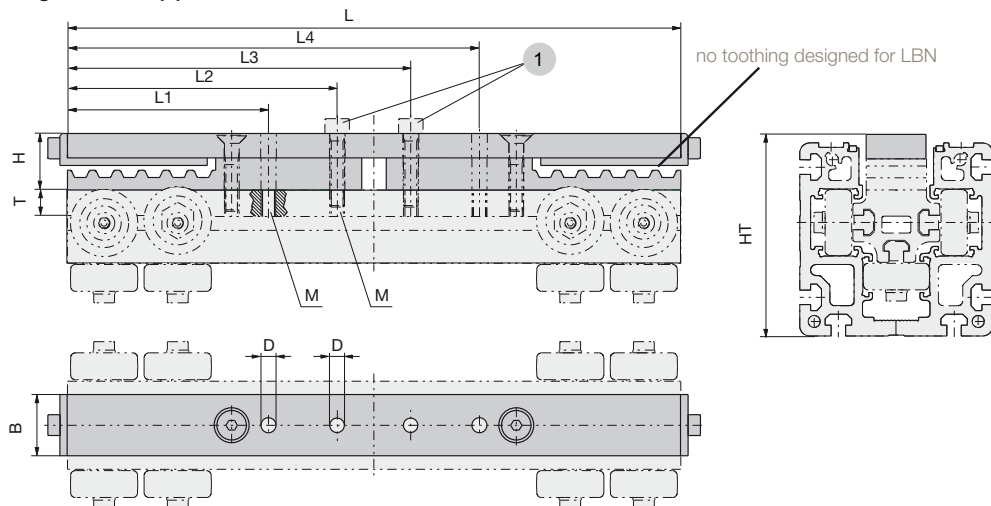

Axis type	Unit	L	L1	L2	L3	L4	B	M	T	H	HT	D
HPLA080T (LBB/LBN)	[mm]	250	82	110	140	168	25	M6	11	23	83.5	Ø6.4
HPLA120T (LBB/LBN)	[mm]	300	90	125	175	210	32	M8	14	23	124	Ø8.2

Extended carriage with bar (F)

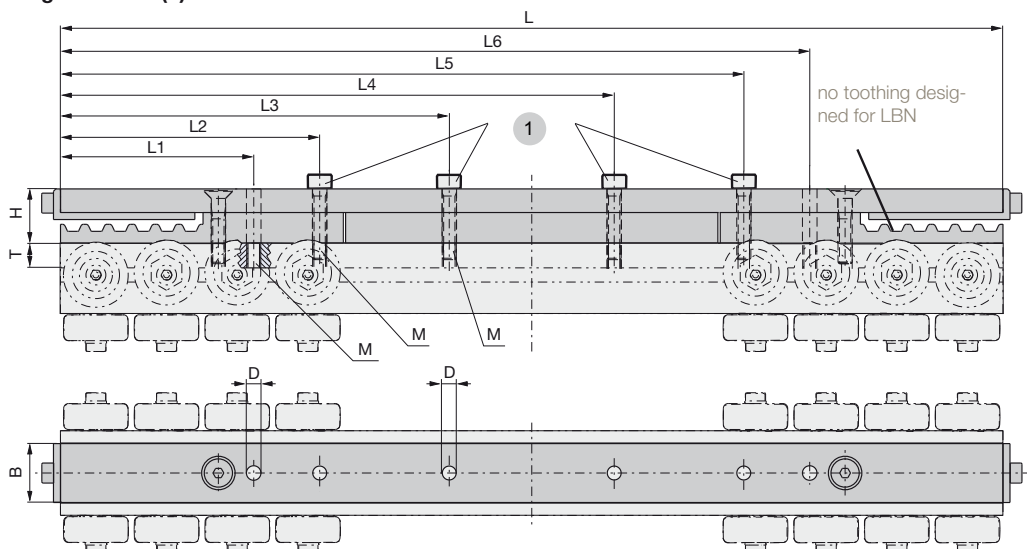

Axis type	Unit	L	L1	L2	L3	L4	L5	L6	B	M	T	H	D
HPLA080F (LBB/LBN)	[mm]	400	82	110	165	235	290	318	25	M6	11	23	Ø6.4
HPLA120F (LBB/LBN)	[mm]	500	90	125	195	305	375	410	32	M8	14	23	Ø8.2

1 The retaining screws are mandatory; they may however be replaced by your own screws.

HPLA180

Standard carriage with bar (T)

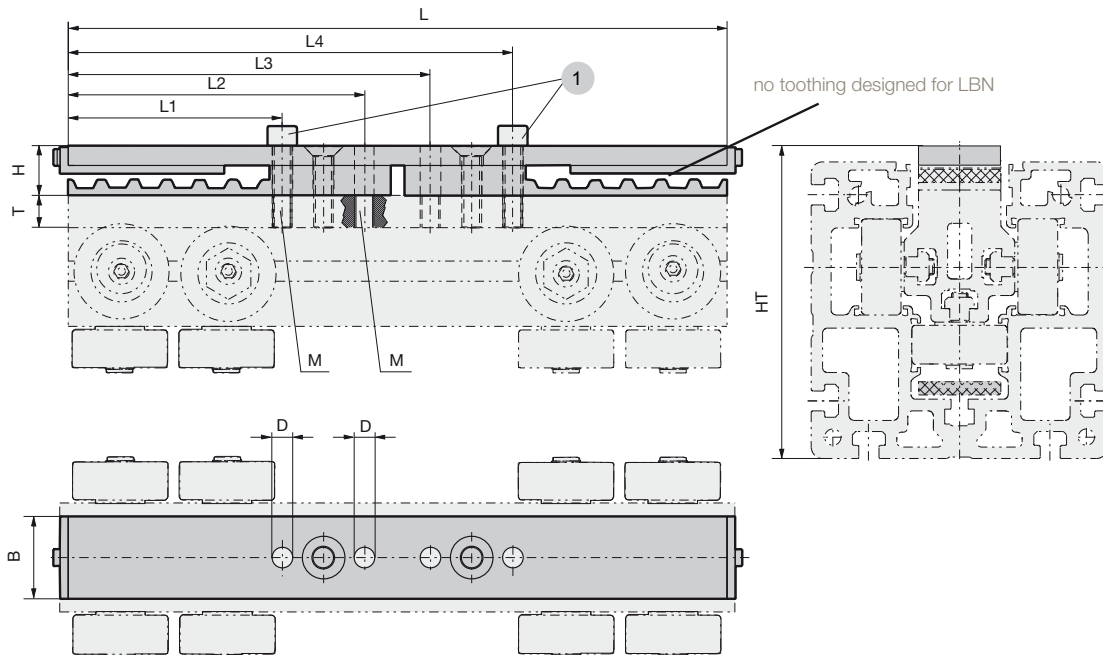

Axis type	Unit	L	L1	L2	L3	L4	B	M	T	H	HT	D
HPLA180T (LBB/LBN)	[mm]	400	130	180	220	270	50	M12	20	33	195.5	Ø12.5

Extended carriage with bar (F)

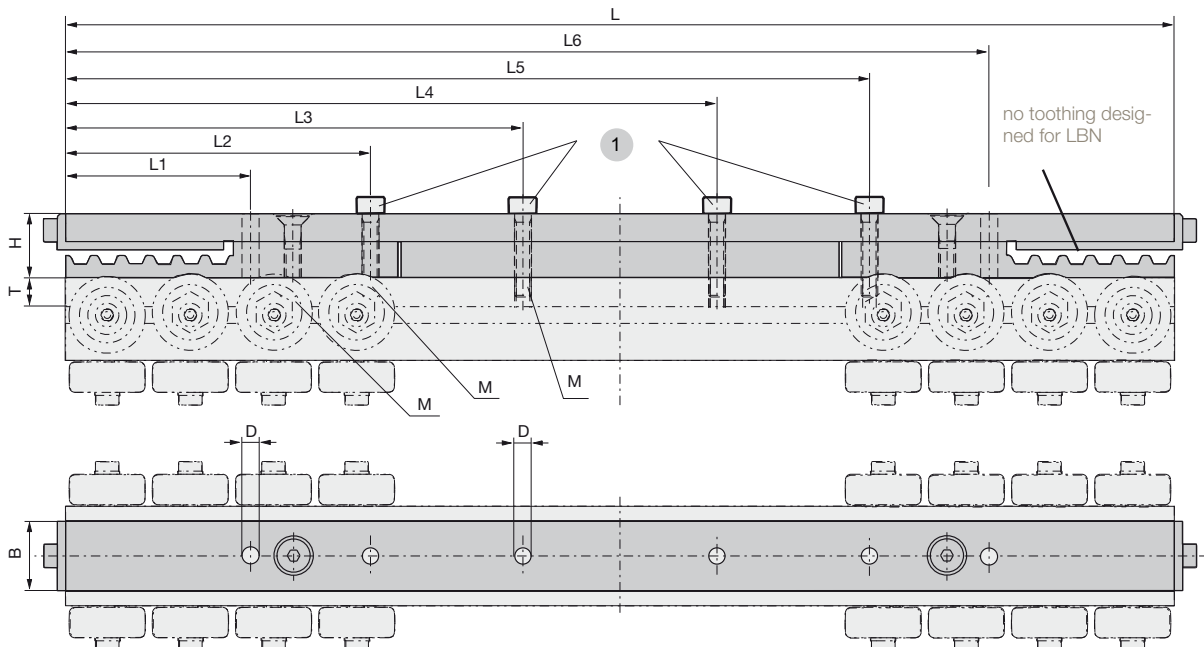

Axis type	Unit	L	L1	L2	L3	L4	L5	L6	B	M	T	H	D
HPLA180F (LBB/LBN)	[mm]	700	130	180	290	410	520	570	50	M12	20	33	Ø12.5

1 The retaining screws are mandatory; they may however be replaced by your own screws.

Possible Drive Combinations

Dimensions [mm]
Schematic representations

HPLA080 (LBB080)

Drive option ¹ →	FL/FR	SL/SR/SB	NL/NR	LR/RL
	Toothed pulley separately included for bearing directly on the shaft, prepared for drive mounting	Housing with drive shaft for gearboxes or motors with hollow shaft	Version with supported hollow shaft without drive - prepared for drive mounting	Supported hollow shaft, A, B, Q, R, K, M Additional drive shaft
↓ Drive flange ¹				
A (for P3/P3V)	Figure 17	not possible	Figure 9	Figure 3
B (for P4/P4V)	Figure 18 only single axis		Figure 10 Figure 23: Double axis drive side	Figure 4 Figure 23: Double axis drive side
K (for PS60)	Figure 19		Figure 11	Figure 5
M (for PS90)	Figure 20 only single axis		Figure 12 Figure 24: Double axis drive side	Figure 6 Figure 24: Double axis drive side
E (for motor MH105/ B9/19)	not possible		Figure 15	non standard
F (for motor MH105/ B6/24)	not possible		Figure 16	non standard
Q (for PE4)	Figure 21		Figure 13	Figure 7
R (for PE5)	Figure 22		Figure 14	Figure 8
N (without flange)	-	Figure 1, Figure 2	-	-

¹ Short designations from the order code on page 54

Drive housing with drive shaft/drive flange

Housing with drive shaft on one side: SL/SR

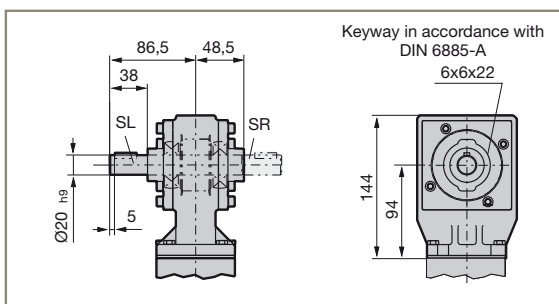

Figure 1

Housing with drive shaft on both sides: SB

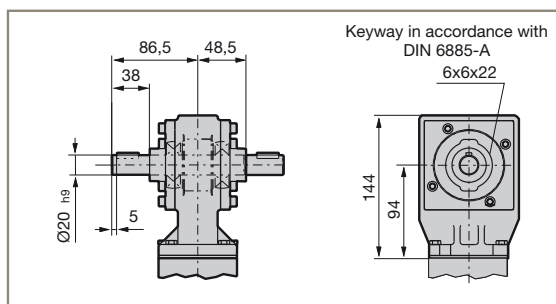

Figure 2

Drive option: LR/RL Drive flange A for P3/P3V

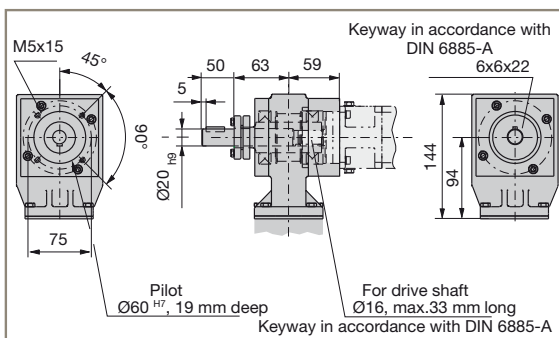

Figure 3

Drive option: LR/RL Drive flange B for P4/P4V

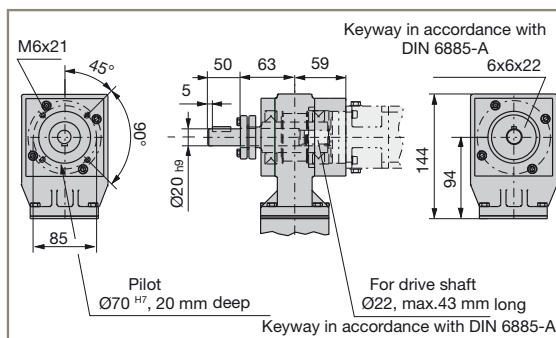

Figure 4

Drive option: LR/RL
Drive flange K for PS60

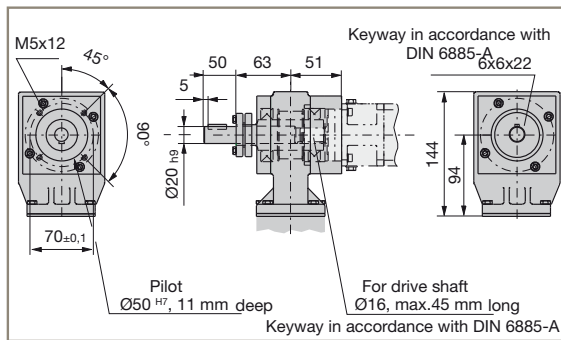

Figure 5

Drive option: LR/RL
Drive flange M for PS90

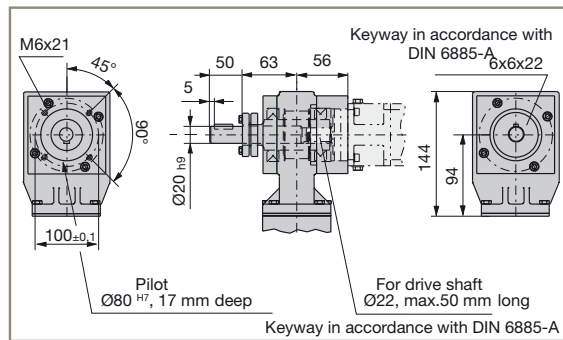

Figure 6

Drive option: LR/RL
Drive flange Q for PE4

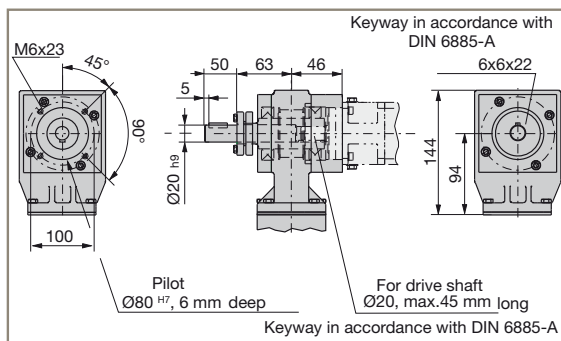

Figure 7

Drive option: LR/RL
Drive flange R for PE5

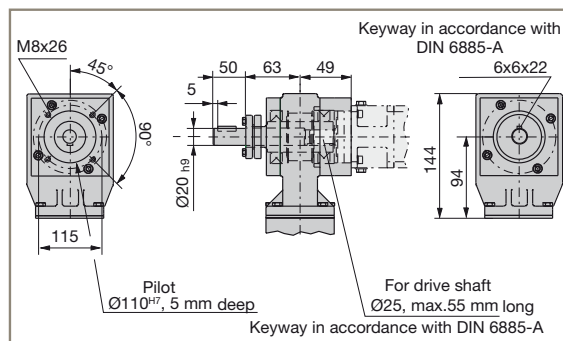

Figure 8

Single axis with hollow shaft or pulley directly on the shaft

Drive option: NL/NR
Drive flange A for P3/P3V

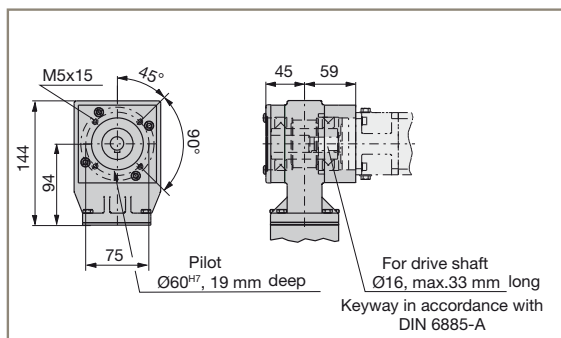

Figure 9

Drive option: NL/NR
Drive flange B for P4/P4V

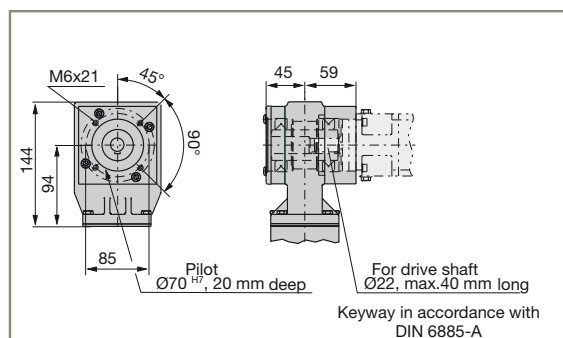

Figure 10

Drive option: NL/NR
Drive flange K for PS60

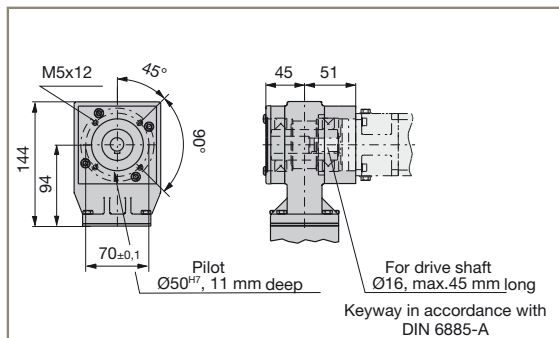

Figure 11

Drive option: NL/NR
Drive flange M for PS90

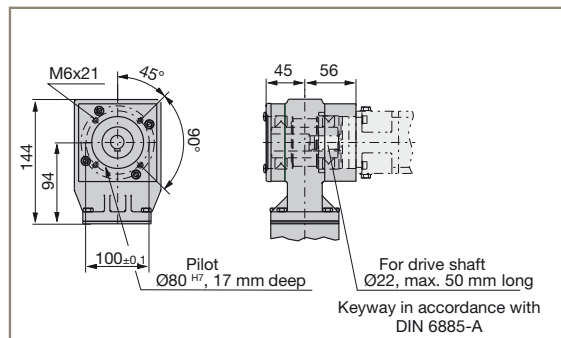

Figure 12

Drive option: NL/NR
Drive flange Q for PE4

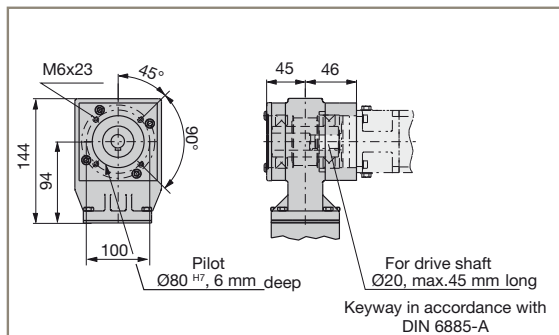

Figure 13

Drive option: NL/NR
Drive flange R for PE5

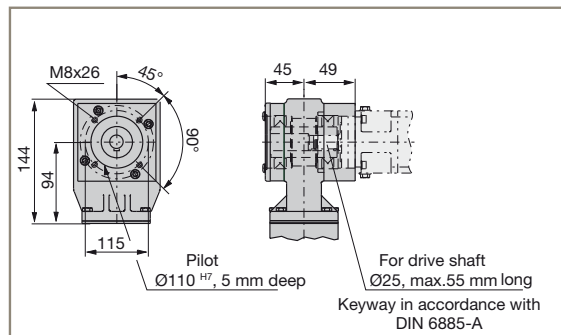

Figure 14

Drive option: NL/NR
Drive flange E for motor MH105/B9/19

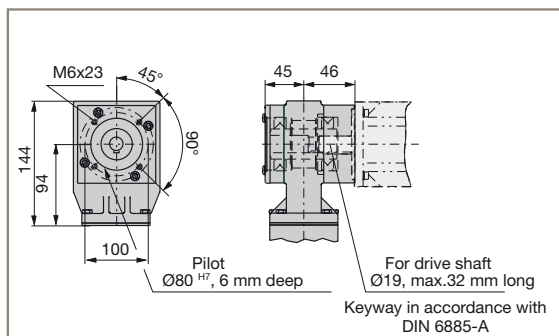

Figure 15

Drive option: NL/NR
Drive flange F for motor MH105/B6/24

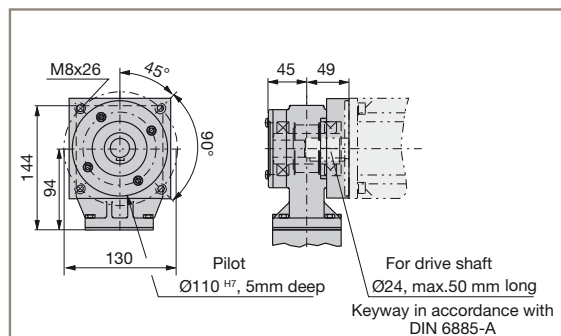

Figure 16

Drive option: FL/FR
Drive flange A for P3/P3V

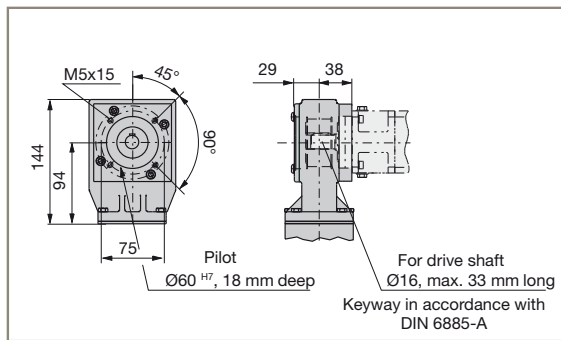

Figure 17

Drive option: FL/FR
Drive flange B for P4/P4V

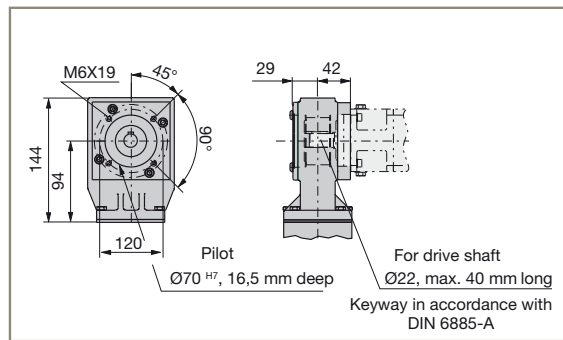

Figure 18

Drive option: FL/FR
Drive flange K for PS60

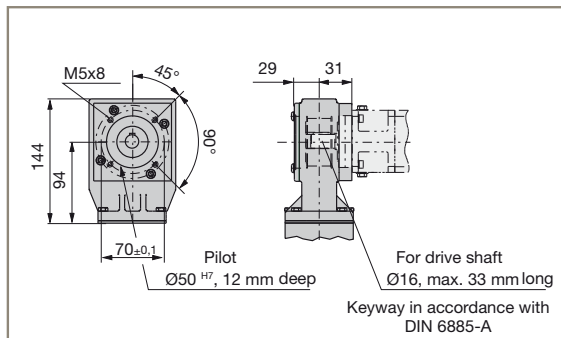

Figure 19

Drive option: FL/FR
Drive flange M for PS90

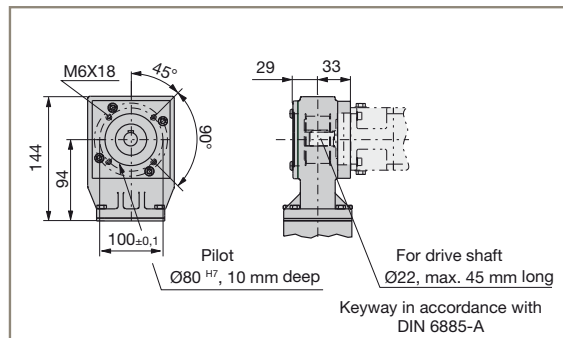

Figure 20

Drive option: FL/FR
Drive flange Q for PE4

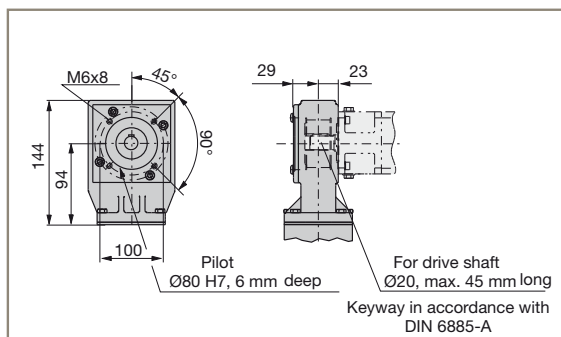

Figure 21

Drive option: FL/FR
Drive flange R for PE5

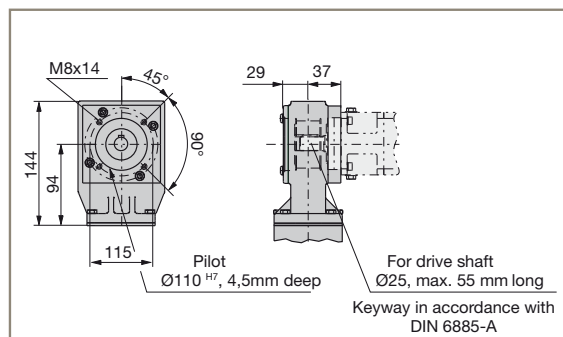

Figure 22

Double axis

Drive option: NL/NR or LR/RL (double axis drive side)
 Drive flange B for P4/P4V

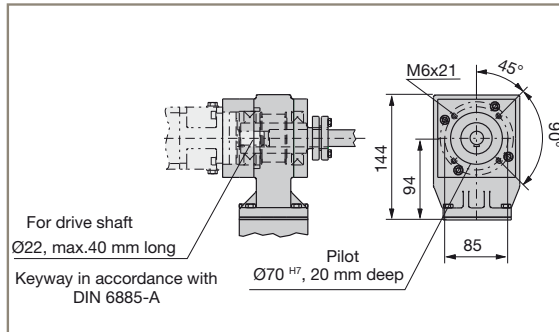

Figure 23

Drive option: NL/NR or LR/RL (double axis drive side)
 Drive flange M for PS90 double axis drive side

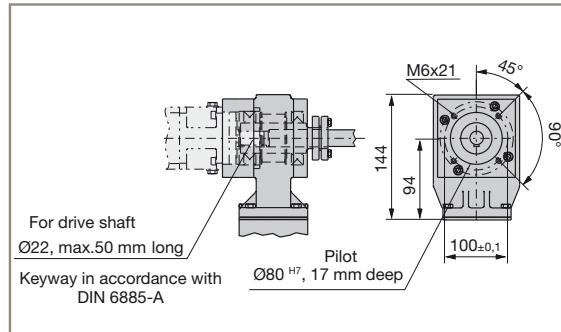
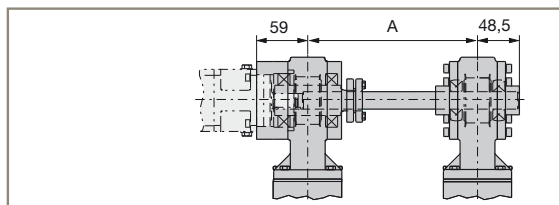

Figure 24

Center distance A:
 Drive flange B for P4/P4V



Center distance A between 120-350 mm

Center distance A:
 Drive flange M for PS90

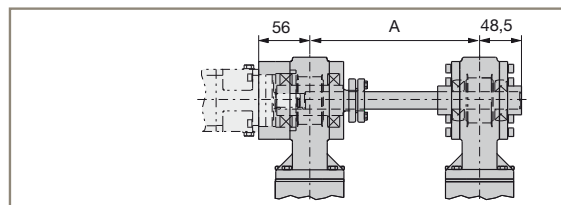

Center distance A between 120-350 mm

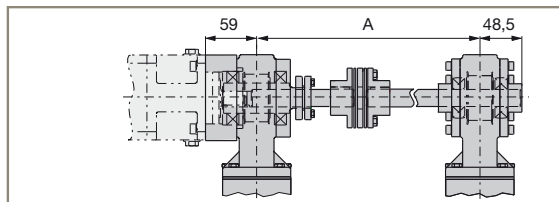

Center distance A between 350-600 mm

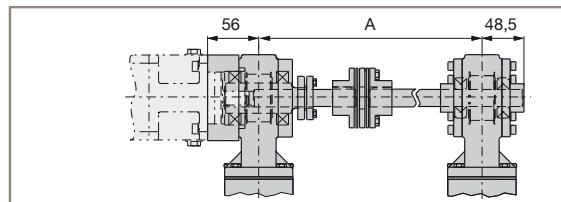

Center distance A between 350-600 mm

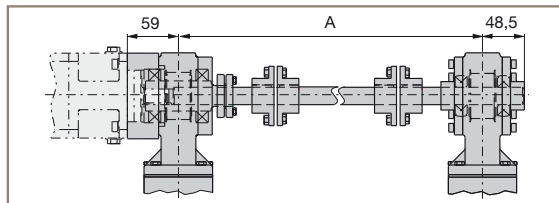

Center distance A larger than 600 mm

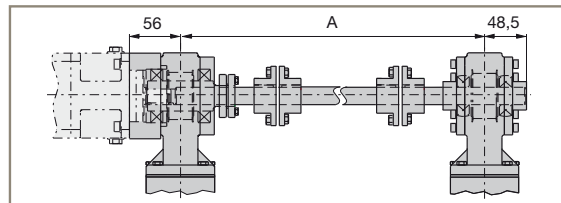

Center distance A larger than 600 mm

HPLA120 (LBB120)

Drive option ¹ →	FL/FR	SL/SR/SB	NL/NR	LR/RL
	Toothed pulley separately included for bearing directly on the shaft, prepared for drive mounting	Housing with drive shaft for gearboxes or motors with hollow shaft	Version with supported hollow shaft without drive - prepared for drive mounting	Supported hollow shaft, B, C, M, P, Q, R Additional drive shaft
↓ Drive flange ¹				
B (for P4/P4V)	Figure 18	not possible	Figure 9	Figure 3
C (for P5/P5V)	Figure 19 only single axis		Figure 10/ Figure 23	Figure 4/ Figure 23
M (for PS90)	Figure 20		Figure 11	Figure 5
P (for PS115)	Figure 21 only single axis		Figure 12/ Figure 24	Figure 6/ Figure 24
G (for motor MH105/ B6/24)	not possible		Figure 15	non standard
H (for Motor HJ155)	not possible		Figure 17	non standard
J (for Motor MH145/ B5/24)	not possible		Figure 16	non standard
Q (for PE4)	not possible		Figure 13	Figure 7
R (for PE5)	Figure 22		Figure 14	Figure 8
N (without flange)	-	Figure 1, Figure 2	-	-

¹ Short designations from the order code on page 54

Drive housing with drive shaft/drive flange

Housing with drive shaft on one side: SL/SR

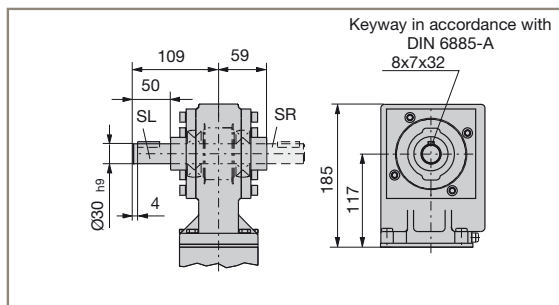

Figure 1

Housing with drive shaft on both sides: SB

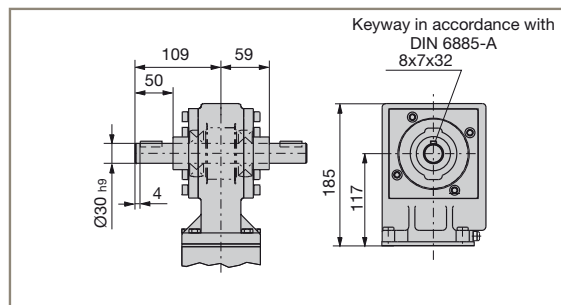

Figure 2

Drive option: LR/RL Drive flange B for P4/P4V

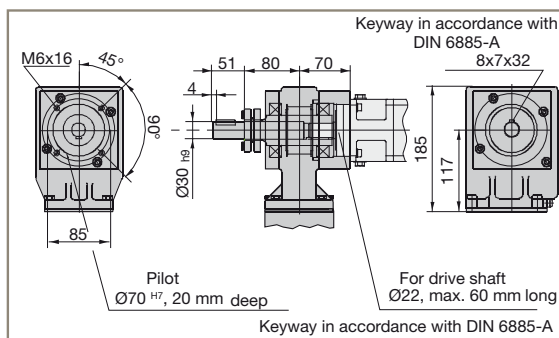

Figure 3

Drive option: LR/RL Drive flange C for P5/P5V

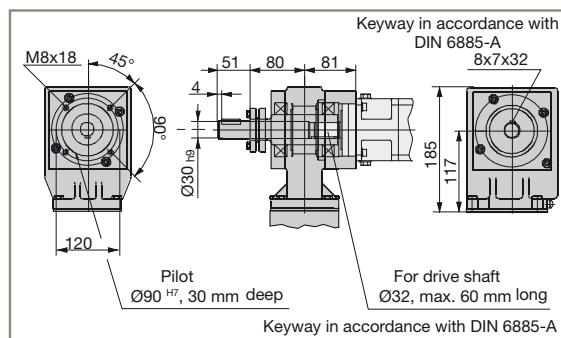

Figure 4

Drive option: LR/RL
Drive flange M for PS90

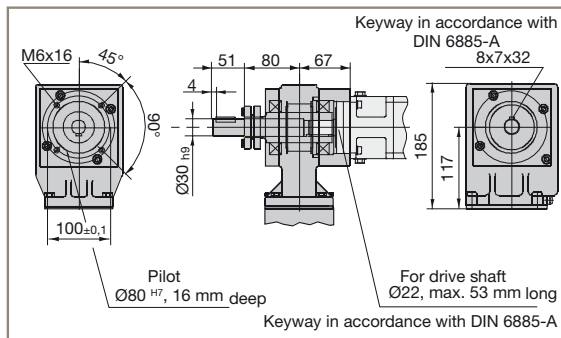

Figure 5

Drive option: LR/RL
Drive flange P for PS115

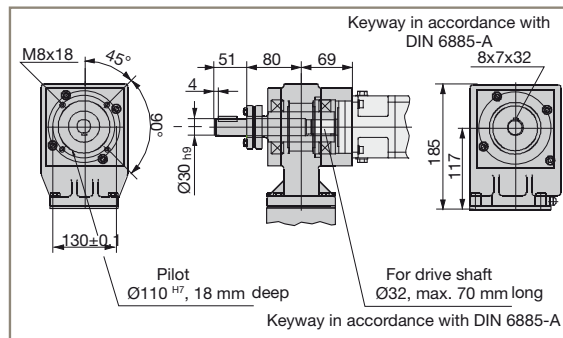

Figure 6

Drive option: LR/RL
Drive flange Q for PE4

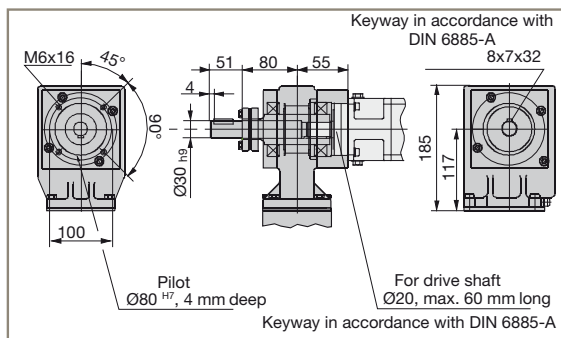

Figure 7

Drive option: LR/RL
Drive flange R for PE5

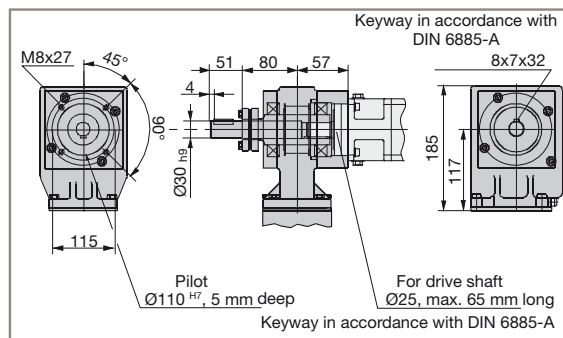

Figure 8

Single axis with hollow shaft or pulley directly on the shaft

Drive option: NL/NR
Drive flange B for P4/P4V

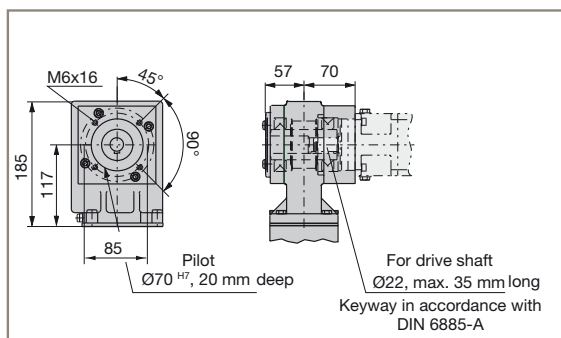

Figure 9

Drive option: NL/NR
Drive flange C for P5/P5V

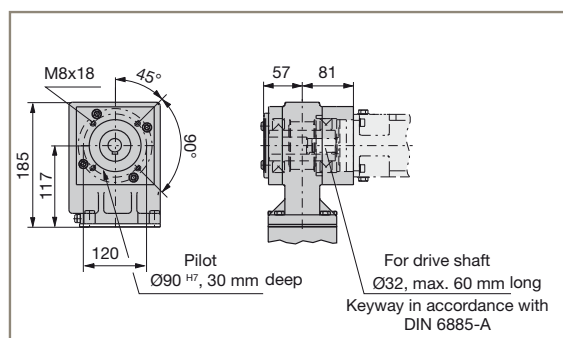

Figure 10

Drive option: NL/NR
Drive flange M for PS90

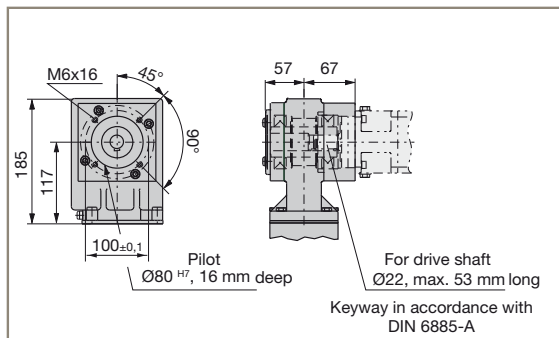

Figure 11

Drive option: NL/NR
Drive flange P for PS115

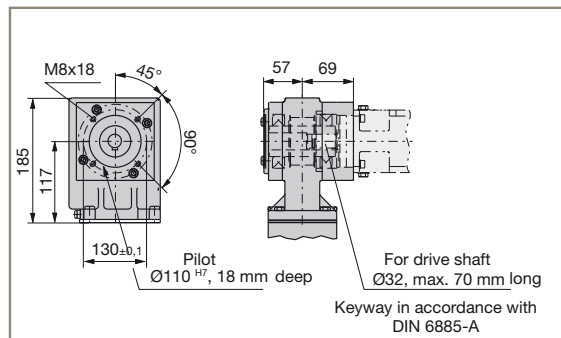

Figure 12

Drive option: NL/NR
Drive flange Q for PE4

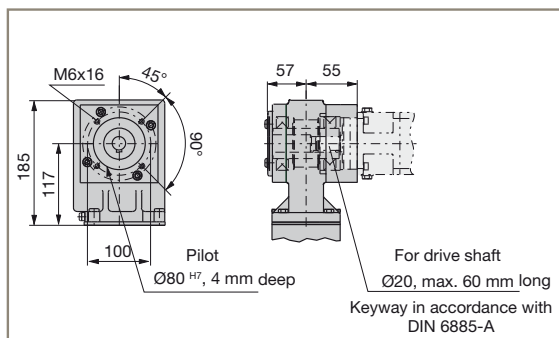

Figure 13

Drive option: NL/NR
Drive flange R for PE5

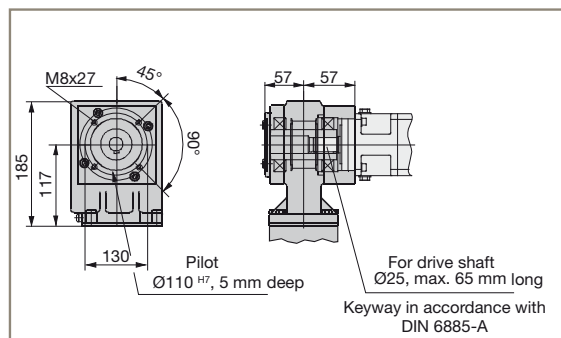

Figure 14

Drive option: NL/NR
Drive flange G for motor MH105/ B6/24

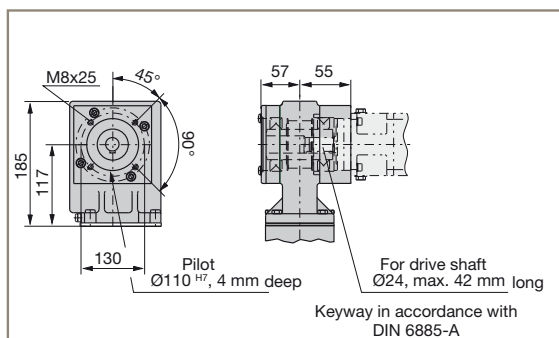

Figure 15

Drive option: NL/NR
Drive flange J for motor MH145/B5/24

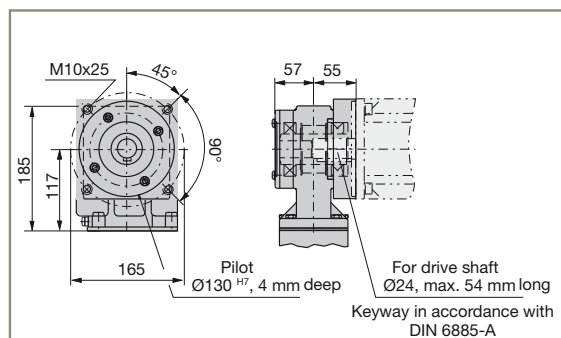

Figure 16

Drive option: NL/NR
Drive flange H for motor HJ155

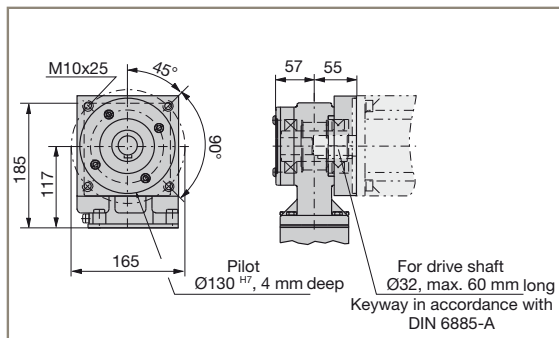

Figure 17

Drive option: FL/FR
Drive flange B for P4/P4V

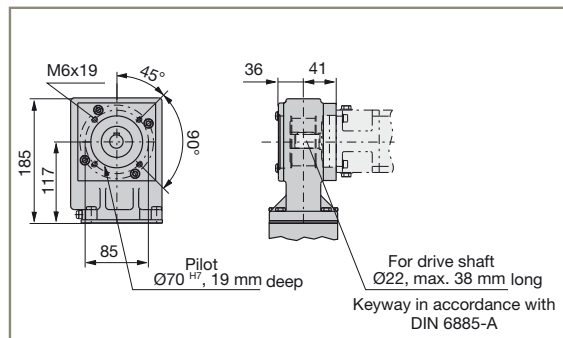

Figure 18

Drive option: FL/FR
Drive flange C for P5/P5V

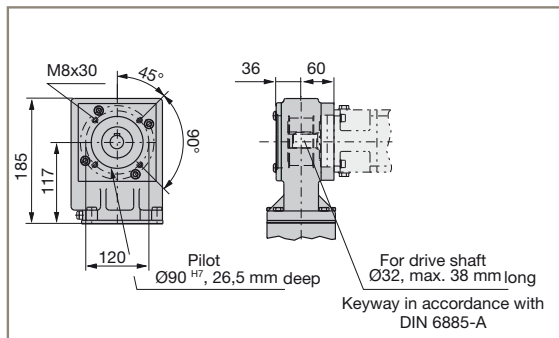

Figure 19

Drive option: FL/FR
Drive flange M for PS90

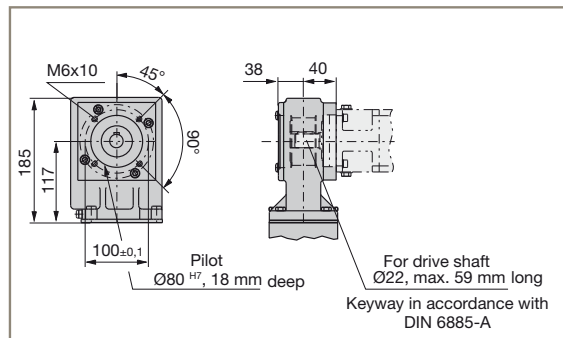

Figure 20

Drive option: FL/FR
Drive flange P for PS115

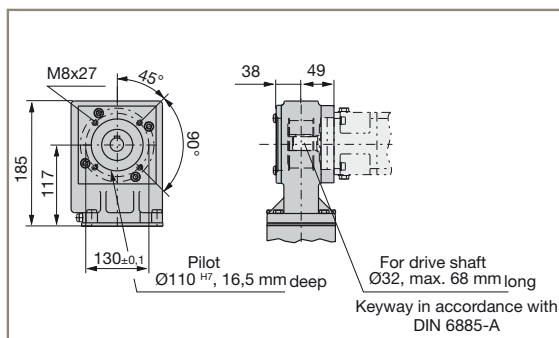

Figure 21

Drive option: FL/FR
Drive flange R for PE5

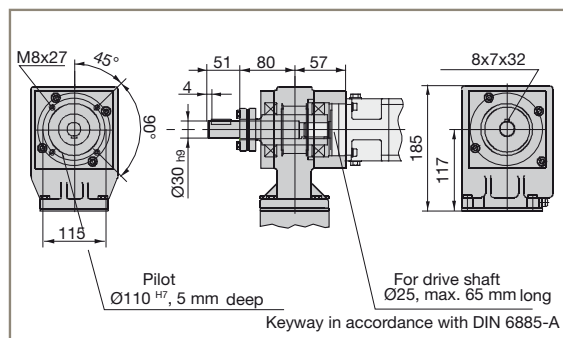

Figure 22

Double axis

Drive option: NL/NR or LR/RL (double axis drive side)
Drive flange C for P5/P5V

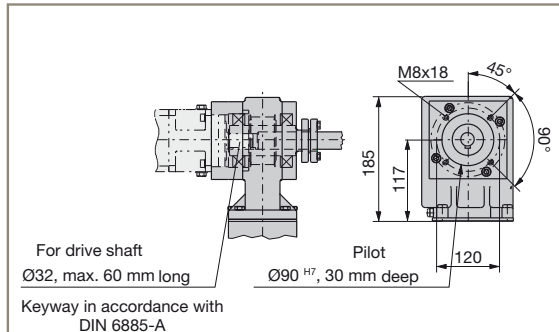

Figure 23

Drive option: NL/NR or LR/RL (double axis drive side)
Drive flange P for PS115

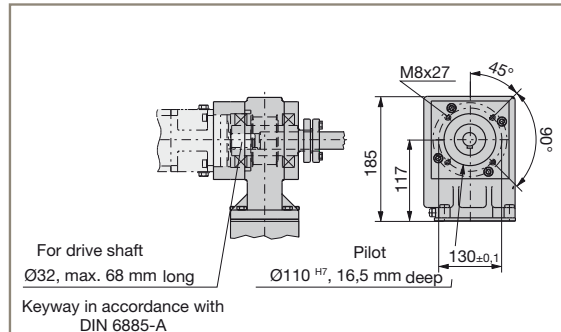
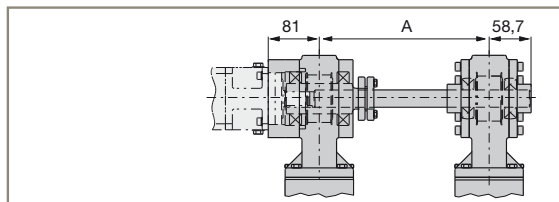

Figure 24

Center distance A:
Drive flange C for P5/P5V



Center distance A between 150-350 mm

Center distance A:
Drive flange P for PS115

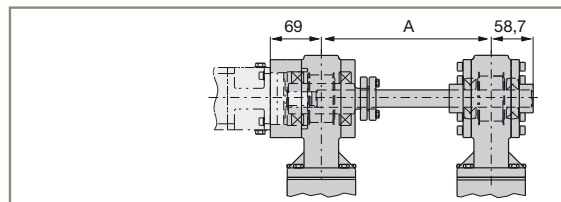

Center distance A between 150-350 mm

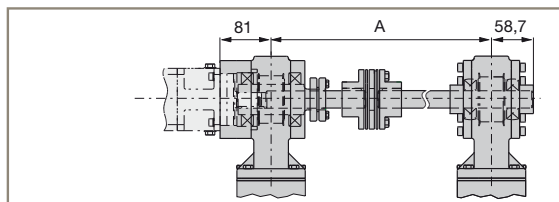

Center distance A between 350-600 mm

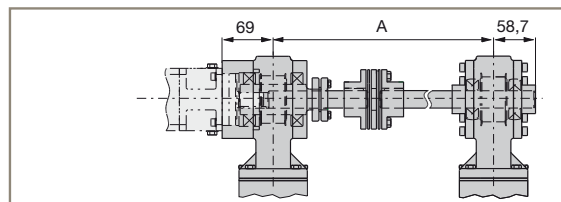

Center distance A between 350-600 mm

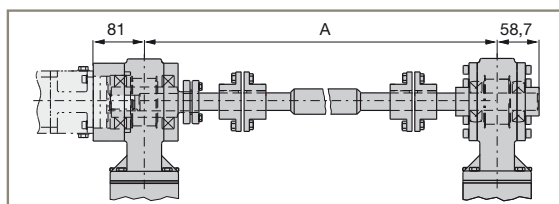

Center distance A larger than 600 mm

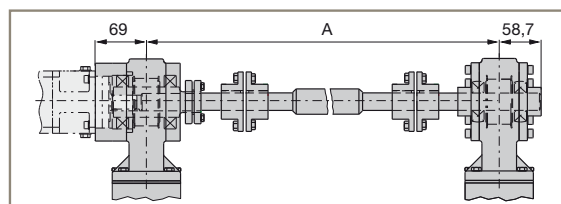

Center distance A larger than 600 mm

HPLA180 (LBB180)

Drive option ¹ →	FL/FR	SL/SR/SB	NL/NR	LR/RL
	Toothed pulley separately included for bearing directly on the shaft, prepared for drive mounting	Housing with drive shaft for drives with hollow shaft	Version with supported hollow shaft without drive - prepared for drive mounting	Supported hollow shaft, C, D Additional drive shaft
↓ Drive flange ¹				
C (for P5/P5V)	Figure 7		Figure 5	Figure 3
D (for P7/P7V)	not possible	not possible	Figure 6/ Figure 8	Figure 4/ Figure 8
N (without flange)	-	Figure 1, Figure 2	-	-

1 Short designations from the order code on page 54

Drive housing with drive shaft/drive flange

Housing with drive shaft on one side: SL/SR

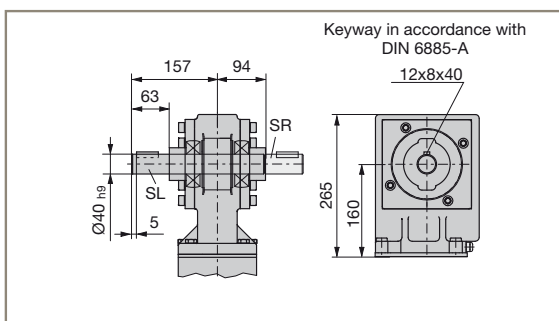

Figure 1

Housing with drive shaft on both sides: SB

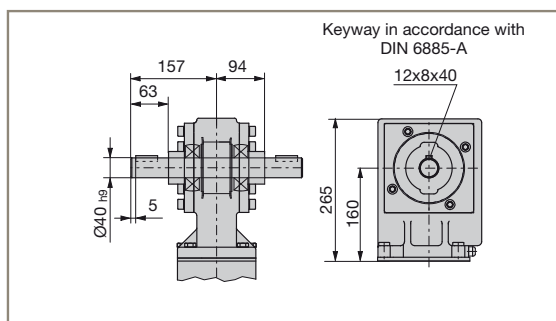

Figure 2

Drive option: LR/RL Drive flange C for P5/P5V

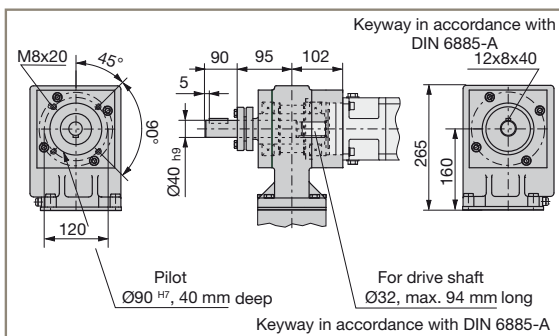

Figure 3

Drive option: LR/RL Drive flange D for P7/P7V

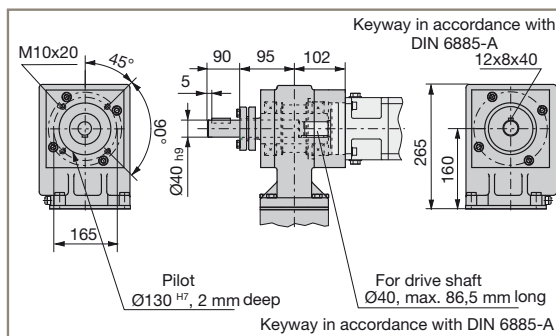

Figure 4

Single axis with hollow shaft or pulley directly on the shaft

Drive option: NL/NR
Drive flange C for P5/P5V

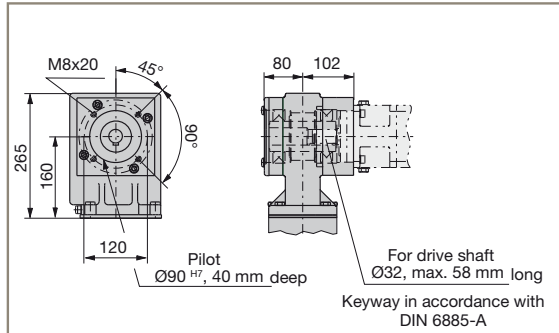

Figure 5

Drive option: NL/NR
Drive flange D for P7/P7V

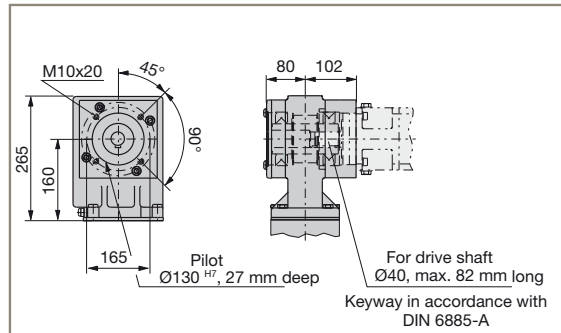

Figure 6

Drive option: FL/FR
Drive flange C for P5/P5V

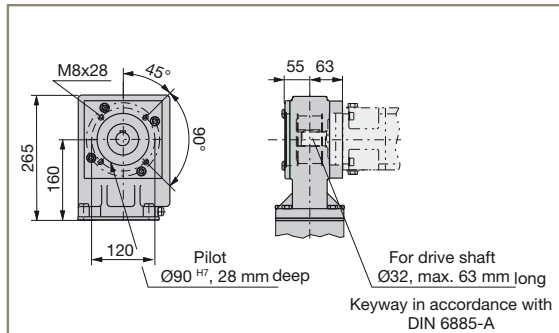

Figure 7

Double axis

Drive option: NL/NR or LR/RL (double axis drive side)
 Drive flange D for P7/P7V

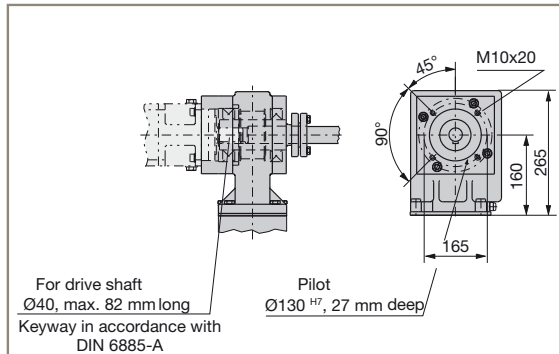
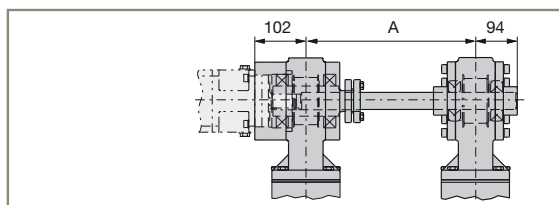
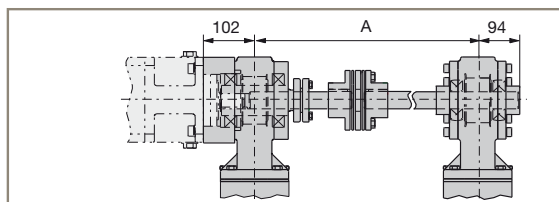

Figure 8

Center distance A:
 Drive flange D for P7/P7V



Center distance A between 180-350 mm



Center distance A between 350-600 mm

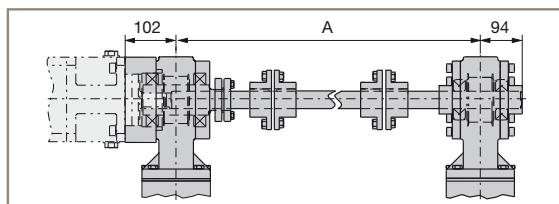

Center distance A larger than 600 mm

Accessories

Dimensions [mm]
Schematic representations

Assembly Angle Plate

The assembly angle plate is used to connect a HPLA:

- to another linear actuator
- with a base (a Parker profile can be used as support)
- to other machine components

It is available in different sizes, isosceles or scalene - each with through holes. Each angle plate can be attached to the load attachment

plate or to the corresponding profile in different directions.

Assembly angle plate isosceles

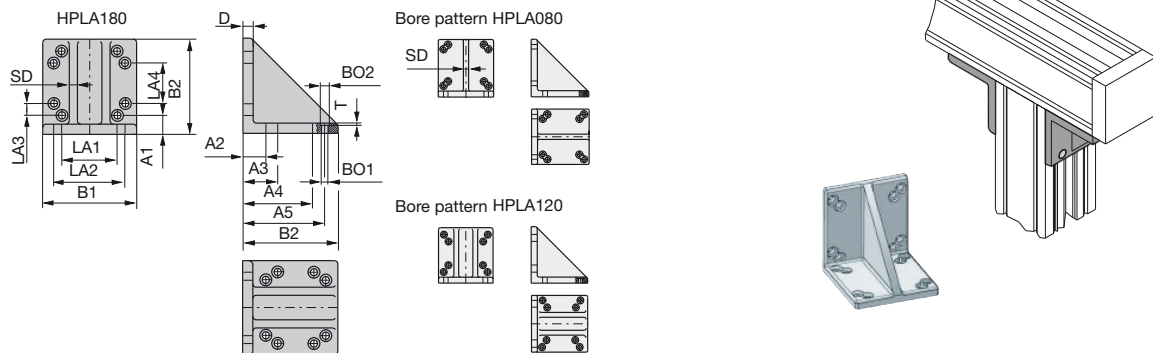

Frame size	A1	A2	A3	A4	A5	BO1	BO2	B1	B2	D	LA1	LA2	LA3	LA4	SD	T	Art. No.
HPLA080	16	16	22	64	70	Ø5.5	Ø10	74	77	8	48	60	6	42	7	3	500-000935
HPLA120	25	25	40	90	105	Ø9	Ø15	110	120	15	70	90	15	50	8	2	500-000945
HPLA180	35	60	80	140	160	Ø11	Ø22	180	180	20	110	140	20	85	12	1	500-000940

Assembly angle plate scalene

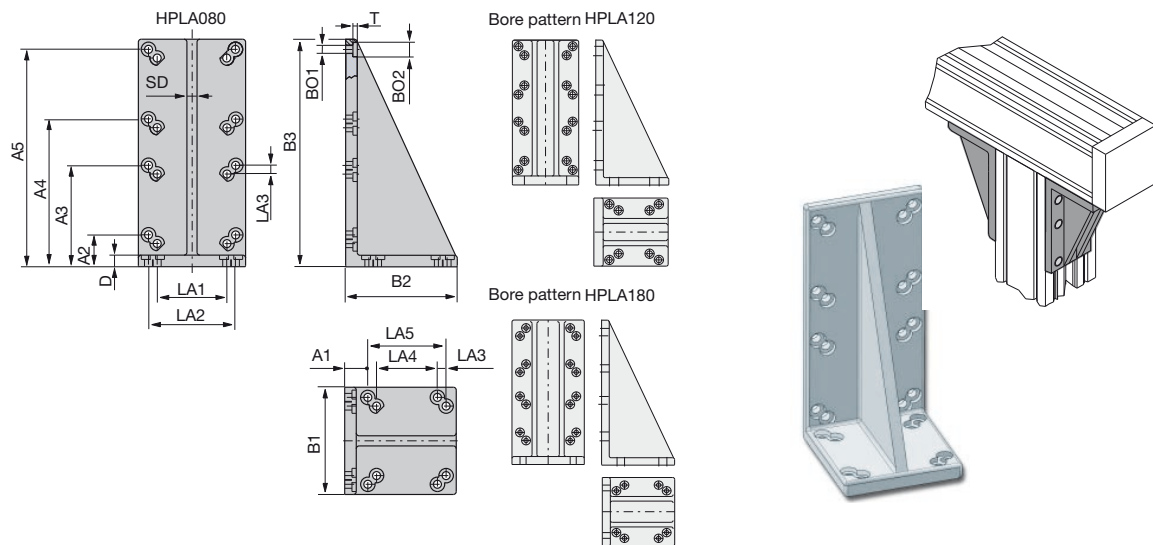

Frame size	A1	A2	A3	A4	A5	BO1	BO2	B1	B2	B3	D	LA1	LA2	LA3	LA4	LA5	SD	T	Art. No.
HPLA080	16	22	70	102	150	Ø5.5	Ø10	74	77	157	8	48	60	6	42	54	7	3	500-000936
HPLA120	25	40	105	165	230	Ø9	Ø15	110	120	240	15	70	90	15	50	80	8	2	500-000946
HPLA180	35	80	170	250	340	Ø11	Ø22	180	180	360	20	110	140	20	85	125	12	1	500-000941

T-Nuts and Bolts

The T nuts and bolts can be used to attach other components in the T-slots of the profile, or on the upper side of the load attachment plate.

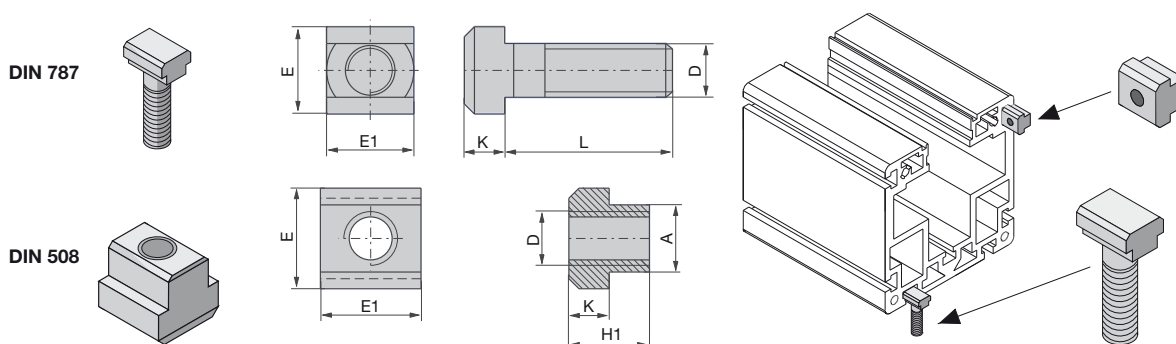

Frame size		Designation	A	D	E	E1	H1	K	L	Art. No.	(stainless)	
HPLA080	T-slot bolt	DIN787 M6x15	--	M6	10	10	--	4	15	131-700030	(135-725430)	
HPLA080	T-slot bolt	DIN787 M6x25	--	M6	10	10	--	4	25	131-700031		
HPLA080	T-slot bolt	DIN787 M6x30	--	M6	10	10	--	4	30	131-700032		
HPLA080	T-slot bolt	DIN787 M6x40	--	M6	10	10	--	4	40	131-700033		
HPLA120	T-slot bolt	DIN787 M10x25	--	M10	15	15	--	6	25	131-700007	(135-725459)	
HPLA120	T-slot bolt	DIN787 M10x32	--	M10	15	15	--	6	32	131-700008	(135-725460)	
HPLA120	T-slot bolt	DIN787 M10x40	--	M10	15	15	--	6	40	131-700009	(135-725465)	
HPLA120	T-slot bolt	DIN787 M10x63	--	M10	15	15	--	6	63	131-700011		
HPLA120	T-slot bolt	DIN787 M10x80	--	M10	15	15	--	6	80	131-700012		
HPLA180	T-slot bolt	DIN787 M12x25	--	M12	18	18	--	7	25	131-700016	(135-725482)	
HPLA180	T-slot bolt	DIN787 M12x50	--	M12	18	18	--	7	50	131-700015	(135-725480)	
HPLA180	T-slot bolt	DIN787 M12x65	--	M12	18	18	--	7	65	131-700025	(135-725468)	
HPLA180	T-slot bolt	DIN787 M12x80	--	M12	18	18	--	7	80	131-700026	(135-725470)	
HPLA080	T-nut	DIN508 M4x6x10	5.6	M4	10	10	8	4	--	131-700101	(135-725391)	
HPLA080	T-nut	DIN508 M5x6x10	5.6	M5	10	10	8	4	--	131-700102	(135-725390)	
HPLA080	T-nut long	HWN313 ZN M5x6	5.6	M5	10	20	8	4	--	131-700147		
HPLA080	T-nut	HWN314 ZN M5x6	Rhombus form for retro-fitting						131-700157			
HPLA120	T-nut	DIN508 M4x10x15	9.6	M4	15	15	12	6	--	131-700134	(135-725403)	
HPLA120	T-nut	DIN508 M6x10x15	9.6	M6	15	15	12	6	--	131-700135		
HPLA120	T-nut	DIN508 M8x10x15	9.6	M8	15	15	12	6	--	131-700104	(135-725402)	
HPLA120	T-nut long	HWN313 M8x10x30	9.6	M8	15	30	12	6	--	131-700141	(135-725406)	
HPLA120	T-nut	HWN314 M8x10	Rhombus form for retro-fitting						131-700155			
HPLA180	T-nut	DIN508 M4x12x18	11.6	M4	18	18	14	7	--	131-700113	(135-725422)	
HPLA180	T-nut	DIN508 M6x12x18	11.6	M6	18	18	14	7	--	131-700112	(135-725421)	
HPLA180	T-nut long	HWN313M10x12x35	11.6	M10	18	35	14	7	--	131-700111	(135-725420)	
HPLA180	T-nut	HWN314 M10x12	Rhombus form for retro-fitting						131-700156			

* When using the combination of two linear actuators via toe clamps, we would recommend the use of long nuts.

Toe Clamp

The toe clamps are used in conjunction with the standard load attachment plate to rapidly install and attach various combinations of linear actuators. Two clamping profiles are needed to fix a HLE/HLEZ/HPLA on a flange plate. The following table shows the required profiles for the different axis combinations:

top bottom	LB..080 (HPLA80)	LE..100 (HLE100)	LB..120 (HPLA120)	LE..150 (HLE150)	LB..180 (HPLA180)
LB..080	Art. No. 500-000931	--	--	--	--
LE..100	Art. No. 500-000932	Art. No. 500-000905	--	--	--
LB..120	Art. No. 500-000930	Art. No. 500-000908	Art. No. 500-000925	--	--
LE..150	--	Art. No. 500-000903	Art. No. 500-900909	Art. No. 500-000902	--
LB..180	--	--	Art. No. 500-000922	Art. No. 500-000921	Art. No. 500-000920

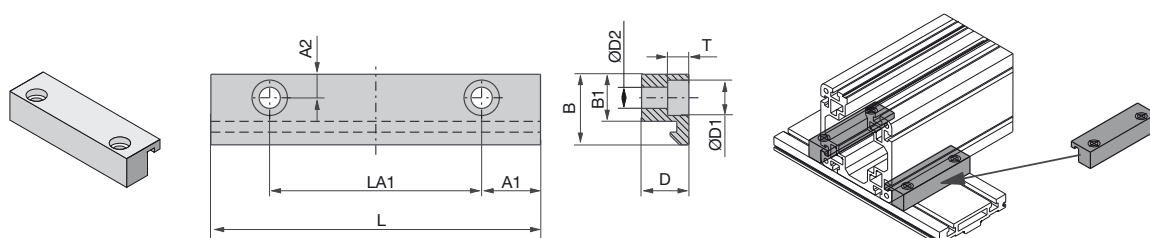

Art. No.	A1	A2	B	B1	D	D1	D2	L	LA1	T
500-000902	25	12	40	25	30	15	9	140	90 ^{±0.2}	9
500-000903	25	10	30	20	20	15	9	140	90 ^{±0.2}	9
500-000905	15	10	30	20	20	11	6.6	90	60 ^{±0.2}	7
500-000908	20	10	30	20	20	15	9	110	70 ^{±0.2}	9
500-000909	25	12.5	37.5	25	26	15	9	140	90 ^{±0.2}	9
500-000920	30	15	45	30	36	18	11	170	110 ^{±0.2}	11
500-000921	30	12	40	25	30	18	11	170	110 ^{±0.2}	11
500-000922	25	12.5	37.5	25	26	18	11	160	110 ^{±0.2}	10.6
500-000925	20	12.5	37.5	25	26	15	9	110	70 ^{±0.2}	9
500-000930	20	10	27	20	17	15	9	110	70 ^{±0.2}	9
500-000931	14	10	27	20	17	10	5.5	76	48 ^{±0.2}	5.7
500-000932	15	10	27	20	17	15	9	90	60 ^{±0.2}	9

External Stop Buffer

The external stop buffer is mounted in the grooves of the HPLA profile and can be adjusted infinitely.

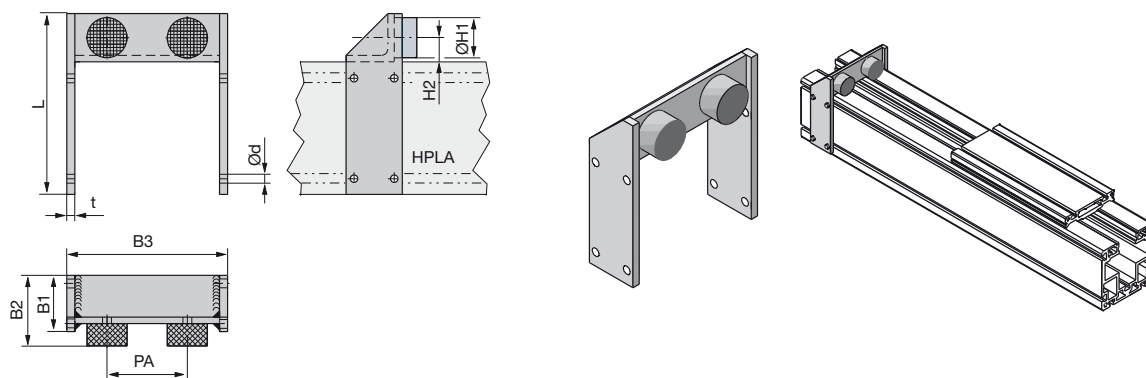

Frame size	B1	B2	B3	PA	d	L	t	ØH1	H2	Art. No. (including mounting material)
HPLA080	30	45	90	56	5.5	91	5	15	11	510-006497
HPLA120	50	60	140	74	9	150	10	30	17	510-007497
HPLA180	70	88	200	100	11	225	10	50	30	510-008497

Longitudinal Flanges

The usable stroke can be more than doubled when using the flange plates. A longitudinal flange is required if the travel path exceeds the profile length (see: "Technical Data", page 14). The separation of the profiles is made, if possible and not stated otherwise, in the middle. The cut-off point of the longitudinal flanges

should always be located near a fixation point. The support distance should be between 1.0 m and 1.5 m. For a HPLA with toothed belt drive and longitudinal flanges, the load characteristics must be derated if the maximum travel is exceeded, (see "Technical data", page 14) and it should only be used with the profile

opening at the top or at the bottom. With a steel roller guiding, max. one longitudinal flange is permitted!

	Unit	HPLA080	HPLA120	HPLA180
maximum permissible load	[N]	$0.5 \times Fx^{*1}$	$0.5 \times Fx^{*1}$	$0.5 \times Fx^{*1}$
Speed	[m/s]	< 1	< 1	< 1
Acceleration	[m/s ²]	< 1	< 1	< 1
Repeatability	[mm]	> ±0.5	> ±0.5	> ±0.5

*1 Fx: (See chapter "Transmissible Forces and Torques" page 16)

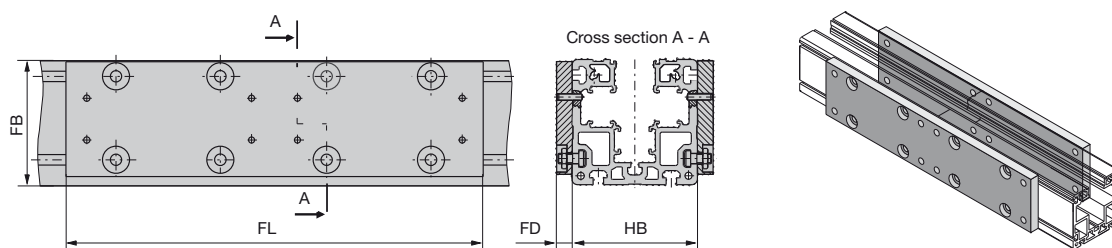

Frame size	FL	FB	FD	HB
HPLA080	300	70	15	80
HPLA120	400	110	15	120
HPLA180	500	165	20	180

Intermediate Shaft Bearing for Double Axes

The intermediate shaft bearing is used to support the connection shaft of a double axis in the event of a long axis distance. The intermediate shaft

bearing must be used if the critical rotational speed is exceeded with the double actuator connection shaft: (see diagram)

Critical rotational speed

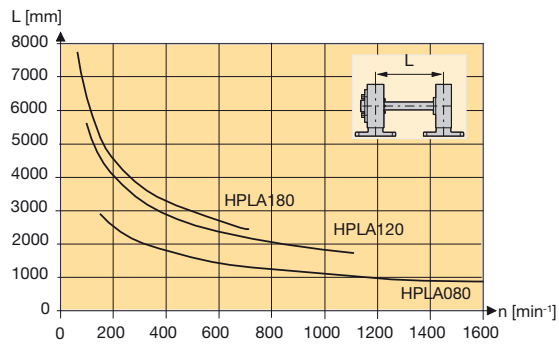

Ratio of rotational speed and speed

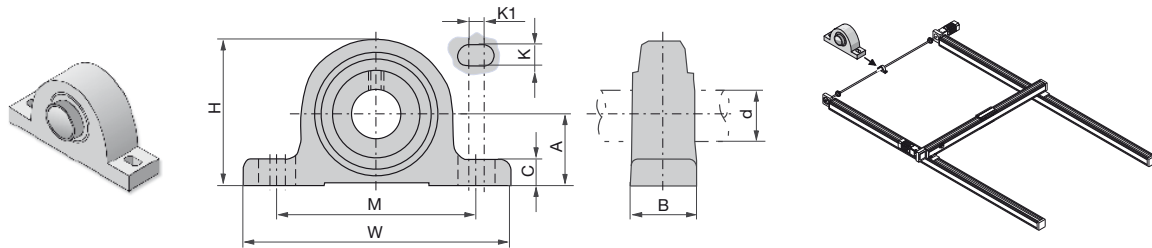
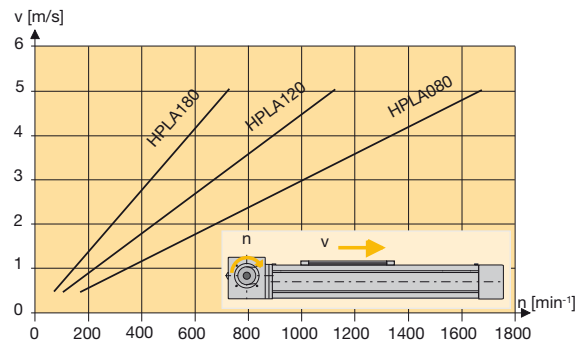

Frame size	Type	A	B	C	d	H	K	K1	M	W	Art. No.
HPLA080	PASE20	33.3	32	14.5	Ø20	64	11	8	97	130	416-000120
HPLA120	PASE40	49.2	48	19	Ø40	99	14	12	138	179	416-000200
HPLA180	PASE50	57.2	54	21.5	Ø50	115	18	5	158	200	416-000210

Position Switch



As a standard, tripping plate, switches and distribution box are mounted on the motor side. Mounting configuration 5 is used as a standard.

The positions of the limit switches and of the machine zero must be set by the customer according to the application requirements.

The end limits should, for instance, be set so that they are activated before the beginning of the safety travel (distance for braking the moved mass see page 20). The tripping plate is enclosed separately into the delivery for the carriage configuration with bar (T/F) (the same applies to the initiator and the limit switches for mounting configuration 3).

Tripping plate, initiators and distribution box are described in this chapter.

Mounting configurations of the position switch

Mounting configuration 2: 3 external electrical initiators

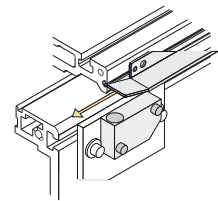
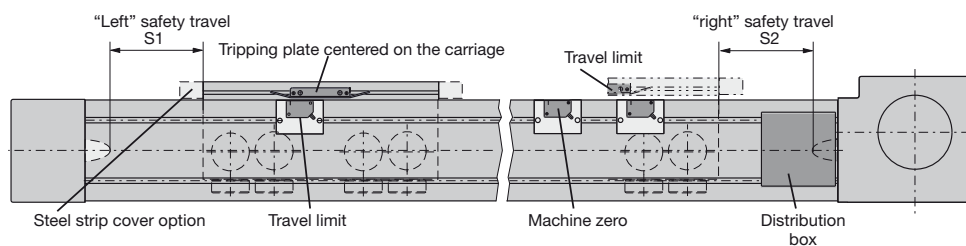

Mounting configuration 3: 2 mechanical limit switches and 1 electrical initiator as home sensor

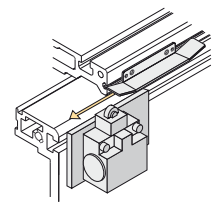
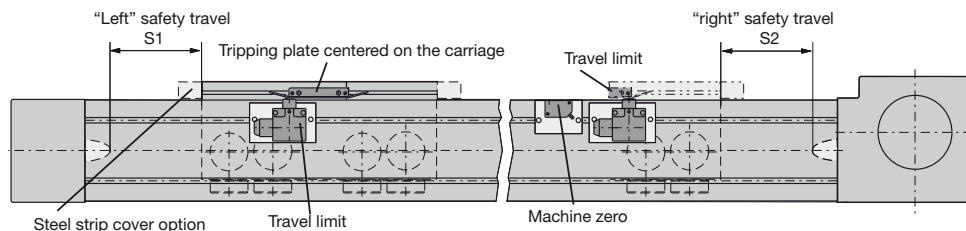

Mounting configuration 4: 1 mechanical limit switch / 1 electrical initiator as home sensor / following

This variant is preferred in robotic systems, if the supply of the switches is made via the cable carrier. The tripping plates must be mounted so that the mechanical switch is actuated immediately before the beginning of the safety travel

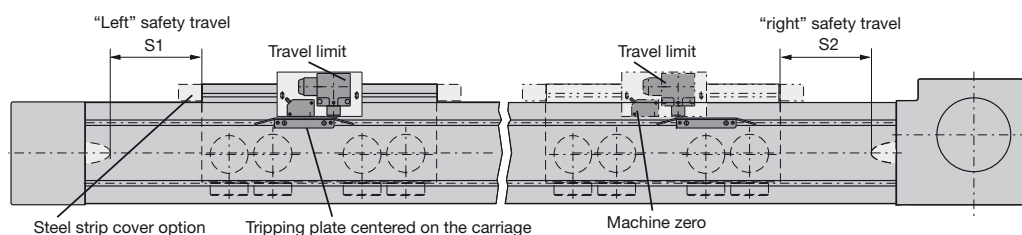

Mounting configuration 5 (standard): 1 electrical initiator

The electrical initiator defines the machine zero. The end limits are software end limits in the Compax3 servo drive.

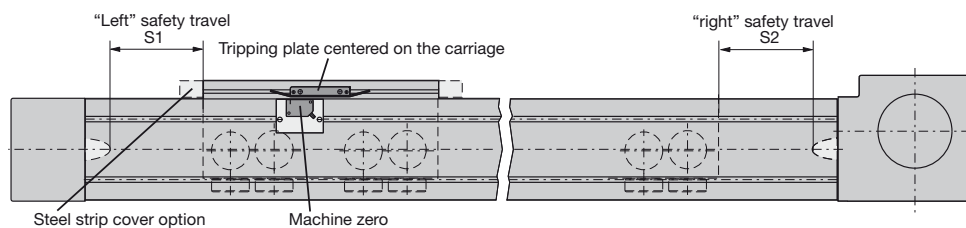

Tripping plate

The tripping plate is suitable for all standard load attachment plates. It is fixed to the load attachment plate with the aid of cylinder head screws and square nuts.

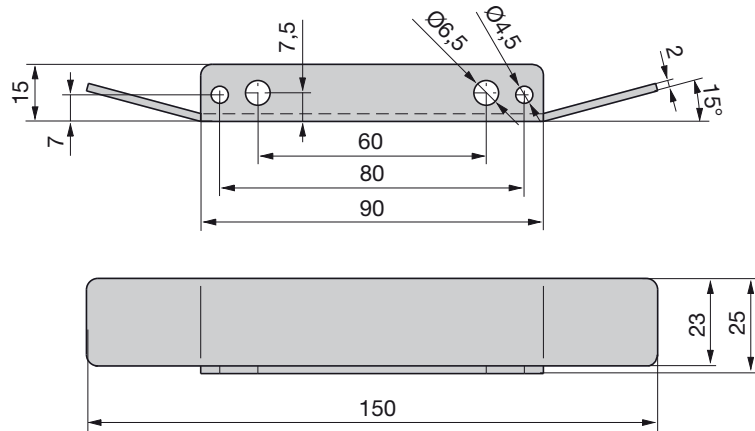
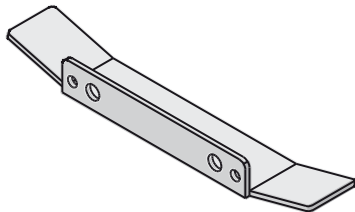

Art. No. Tripping plate: 500-000531
 Art. No. Square nut (2 pcs. required): 135-700001
 Art. No. Cylinder head screw M4x6 (2 pcs. required): 130-302294

Mechanical limit switch

The switching button corresponds to DIN EN 50047. The contacts satisfy the safety requirements by forced opening in accordance with EN 60947-5-1.

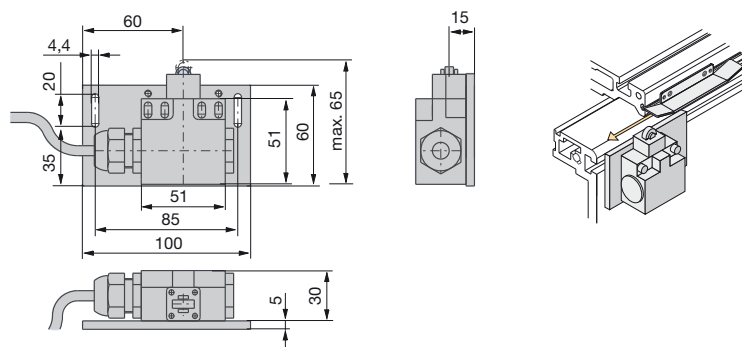
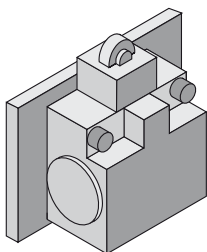

Frame size	Designation	Art. No.
HPLA080	Mechanical limit switch with fixing material	510-900705
HPLA120	Mechanical limit switch with fixing material	510-900505
HPLA180	Mechanical limit switch with fixing material	510-900675

Electrical initiator

The initiators are activated by a tripping plate on the side on the flange plate.

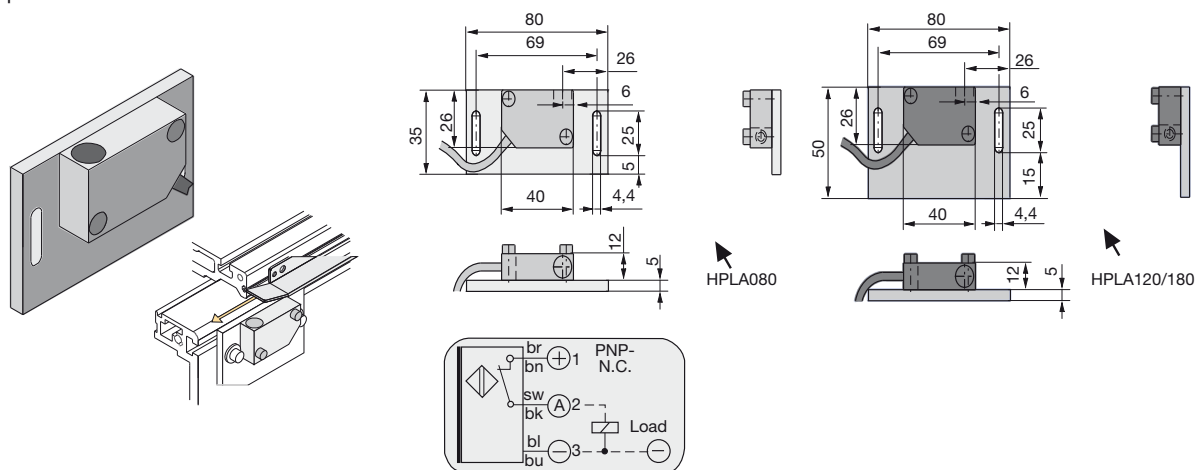

Frame size	Designation	Art. No.	
		Standard design	Stainless version
HPLA080	Electrical limit switch NPN normally closed contact with 6 m cable and fixing material	510-900702	on request
HPLA080	Electrical limit switch NPN normally open contact with 6 m cable and fixing material	510-900700	on request
HPLA080	Electrical limit switch PNP normally closed contact with 6 m cable and fixing material	510-900701	on request
HPLA080	Electrical limit switch PNP normally open contact with 6 m cable and fixing material	510-900703	on request
HPLA080	PNP normally closed contact, pluggable	510-900704	on request
HPLA120	Electrical limit switch NPN normally closed contact with 6 m cable and fixing material	510-900527	510-900622
HPLA120	Electrical limit switch NPN normally open contact with 6 m cable and fixing material	510-900525	510-900620
HPLA120	Electrical limit switch PNP normally closed contact with 6 m cable and fixing material	510-900602	510-900621
HPLA120	Electrical limit switch PNP normally open contact with 6 m cable and fixing material	510-900528	510-900623
HPLA120	PNP normally closed contact, pluggable	510-900603	on request
HPLA180	Electrical limit switch NPN normally closed contact with 6 m cable and fixing material	510-900652	on request
HPLA180	Electrical limit switch NPN normally open contact with 6 m cable and fixing material	510-900653	on request
HPLA180	Electrical limit switch PNP normally closed contact with 6 m cable and fixing material	510-900650	on request
HPLA180	Electrical limit switch PNP normally open contact with 6 m cable and fixing material	510-900651	on request
HPLA180	PNP normally closed contact, pluggable	510-900654	on request

Distribution box



Only for limit switch attachment variant 2

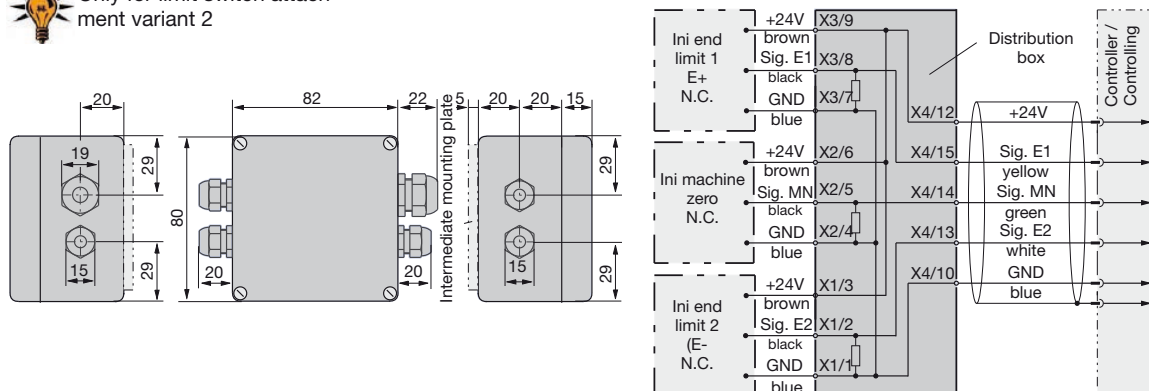

Designation	Art. No.
Distribution box including 2.5 m cable	800-003102
Distribution box including 5 m cable	800-003103
Distribution box including 7.5 m cable	800-003104
Distribution box including 10 m cable	800-003105
Distribution box including 12.5 m cable	800-003106
Distribution box including 15 m cable	800-003107
Distribution box including 20 m cable	800-003108
Distribution box including 25 m cable	800-003109
Distribution box including 30 m cable	800-003110
Distribution box including 35 m cable	800-003111
Distribution box including 40 m cable	800-003112
Distribution box including 45 m cable	800-003113
Distribution box including 50 m cable	800-003114

Frame size	Designation (Art. No. of the distribution boxes: see table above)	Art. No.	
		Standard	Stainless version
HPLA080	Attachment components for distribution box	510-900710	510-900712
HPLA120	Attachment components for distribution box	510-900612	510-900613
HPLA180	Attachment components for distribution box	510-900670	510-900672

Linear Encoder

The use of a linear encoder increases the static position stiffness of the linear actuator as well as the control properties and positioning accuracy. Static stiffness - the capacity to maintain the current position even when exposed to a permanently effective external force (for example processing forces).

An additional cable carrier is required

due to the moving sensor (see page 49).

Caution!



The cable connected to the sensor is not suitable for use in a cable carrier chain, therefore an additional clamping bar to fix a highflex cable is required. As a standard and if not stated

otherwise, the linear encoder is placed on the drive motor side. Unless, please state "mounting right" or "mounting left" in your order (see figure below).

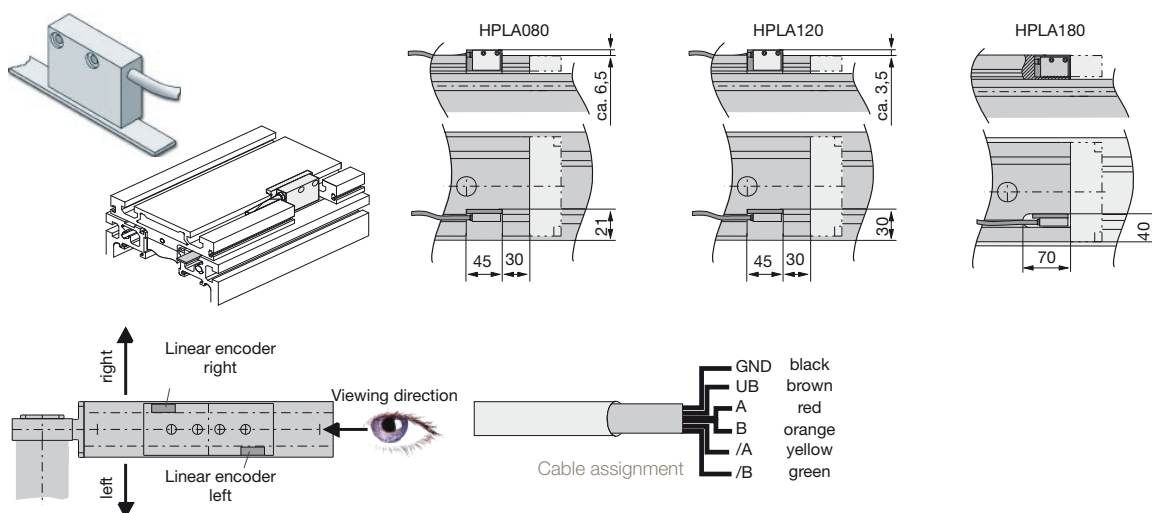

Technical data of MSK500 magnet sensor (incremental) (Order No.: 035-400014)

Characteristic	Technical data	Characteristic	Technical data
Operating voltage	24 VDC $\pm 20\%$	Output signals	A, /A, B, /B
Connection type / cable length	flying leads, 2 m cable	Distance sensor / magnetic strip	0.1 - 2.0 mm
Output circuit	LD Line Driver (RS422)	System precision (sensor system!)	$\pm(0.025 + 0.01 \times L)$ mm (L in m)
Reference signal	none	Interference protection class	3 in accordance with IEC 801
Resolution	0.01 mm	Temperature range	-10 °C to +70 °C
Pulse interval	1 μ s	Protection class	IP67 in accordance DIN 40050 (housing)
Maximum travel speed*	6.9 m/s	Material housing / cable	Black plastic / PUR
Electric current drain	max. 70 mA		

* The maximum travel speed depends on the resolution and on the pulse interval

Technical data of magnetic strip MB500 (Order No.: 035-400015)

Characteristic	Technical data	Characteristic	Technical data
Length	please state desired length (Standard: Length = length of profile)	Reference point	none
Width	10 mm	Temperature coefficient	(11 \pm 1) μ m/K
Thickness	1.7 mm	Temperature range	-10 °C to +70 °C
Precision class	0.1	Mounting type	Adhesive bond
Masking tape	with masking tape	Test mark	CE

Cable Carrier

A cable carrier is needed when making power connections to moving elements. The cable carrier chain consists of Igu-mid® and the support profile is made of aluminum.



The process for fully determining the dimensions of a cable carrier is very complex. The examples listed below represent simple applications, but more data will normally be required when the situation is less straightforward. **The following descriptions are only valid for cable carriers in horizontal configuration supported by a profile - within the limits stated in the technical specifications.** If your application is more complicated, please contact us.

Dimensions of supporting profile and carrier chain

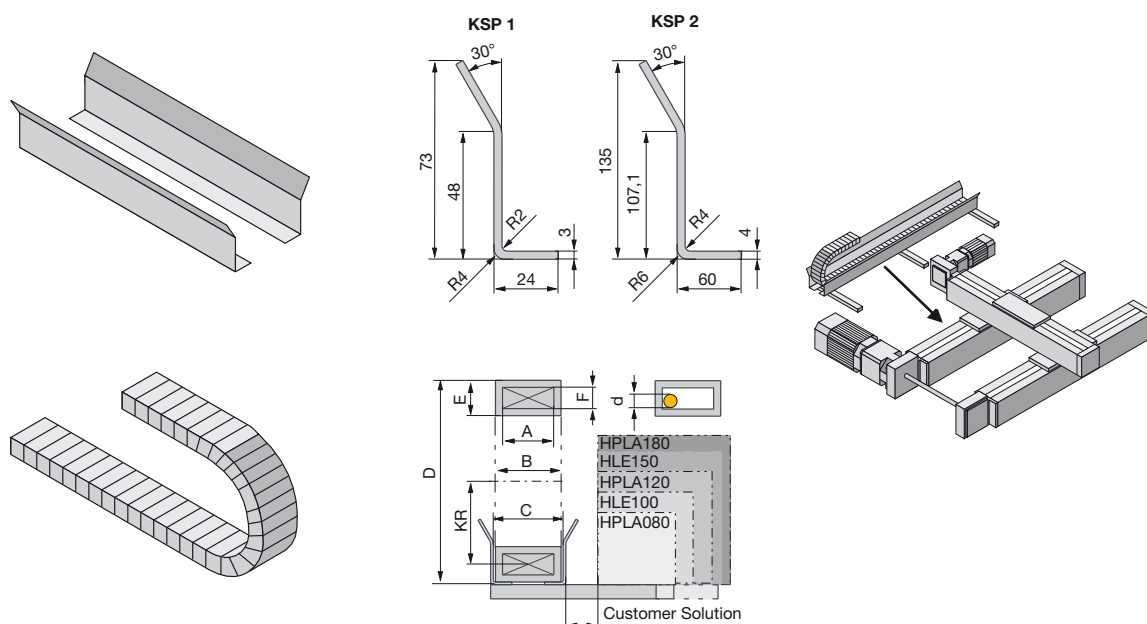

	Type	KR	A	B	C	D max.	E	F	d max.	Art. No. (Length, see chapter: Determination of the chain length)	
										Cable carrier chain	Connection elements fix point and driving plate (inelastic) (please refer to the next page)
with KSP1	B15.015.038.0	38	15	26	31	120	23	17.5	14	100-905150	100-905006
	B15.025.038.0	38	25	36	41	120	23	17.5	14	100-905170	100-905178
	2500.03.055.0	55	38	54	61	170	35	25	23	100-905810	100-905818
	2500.03.100.0	100	38	54	61	260	35	25	23	100-905830	100-905838
	2500.05.100.0	100	57	73	78	260	35	25	23	100-905850	100-905858
	2500.07.150.0	150	77	93	98	360	35	25	23	100-905860	100-905868
with KSP2	2700.07.200.0	200	75	91	96	485	50	35	32	100-905861	100-905869
	2700.12.200.0	200	125	141	146	485	50	35	32	100-905921	100-905928
	2700.17.200.0	200	175	194	199	485	50	35	32	100-905960	100-905968
KSP1 small cable supporting profile (Please state required length. Length = stroke										400-010120	
KSP2 large cable supporting profile (Please state required length. Length = stroke										400-010121	

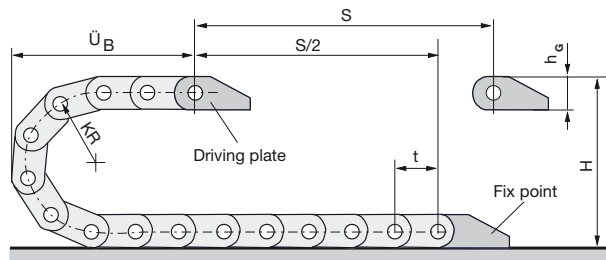

Dimensional drawings of the connection elements
(fixed point and driving plate, both inelastic): see on the next page

Type	Bending radius KR	Pitch t	Height h _G	Curve protrusion Ü _B	Connection height H	Clearance mounting height H _F	Own chain weight [kg/m]
B15.015.038.0	38	30.5	23	80	100	120	≈ 0.35
B15.025.038.0	38	30.5	23	80	100	120	≈ 0.40
2500.03.055.0	55	46	35	125	145	170	≈ 0.81
2500.03.100.0	100	46	35	170	235	260	≈ 0.81
2500.05.100.0	100	46	35	170	235	260	≈ 0.90
2500.07.150.0	150	46	35	220	335	360	≈ 1.01
2700.07.200.0	200	56	50	275	450	485	≈ 1.30
2700.12.200.0	200	56	50	275	450	485	≈ 1.48
2700.17.200.0	200	56	50	275	450	485	≈ 1.85

Dimensional drawings of the connection points

for type B15.xxx

Standard fixed point connection (inelastic)

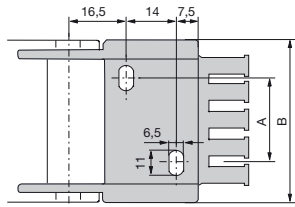

Standard carrier connection

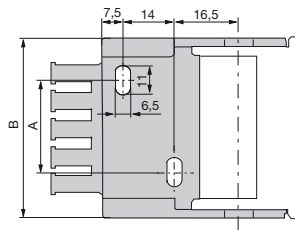

for type 2500.xxx

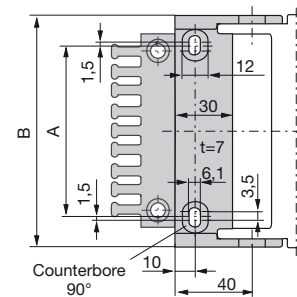
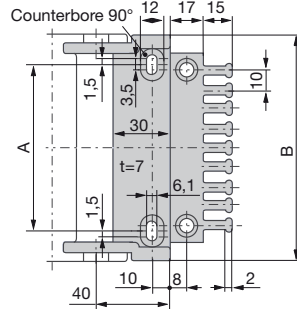

for type 2700.xxx

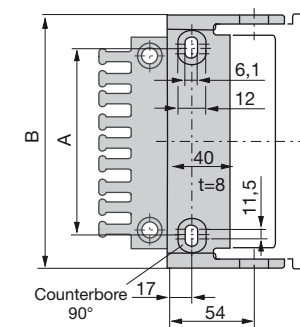
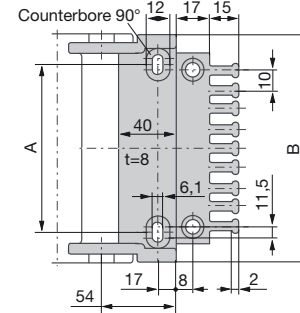

Type	A	B
B15.015..	0	25.5
B15.025..	10	35.5

Type	A	B
2500.03..	25	51
2500.05..	44	70
2500.07..	64	90

Type	A	B
2700.07..	55	93
2700.12..	105	143
2700.17..	155	196

Technical data

for type	Cantilever configuration			Cantilever configuration with permitted sag		
	max. travel [mm]	max. speed [m/s]	max. acceleration ¹ [m/s ²]	max. travel ² [mm]	max. speed [m/s]	max. acceleration [m/s ²]
B15.xx	2000	10	20	2400	3	6
2500.xx	2300	10	20	4000	3	6
2700.xx	3000	10	20	4300	3	6

¹ Higher speeds or accelerations will reduce the lifetime of the cable carrier.
Usual lifetime range with cantilever configuration: 5 - 10 Million strokes.

² For longer strokes, a sliding chain configuration is used. Please contact the supplier.

Guidelines for using cable carriers



Use only electrical cables suitable for use in cable carriers. Hose lines should be highly flexible and should only extend or shorten slightly under pressure. Weight should be distributed across the cable track as evenly as possible! Cables must not be twisted when routed in the cable carrier and should be routed next to one another and as loosely as possible.

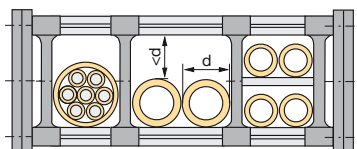

Avoid laying several lines on top of each other and laying lines of different diameters directly next to one another. If multiple layers must be used, separating strips should be inserted between each layer - should such circumstances arise, please contact Parker.

If there is no alternative to routing several lines beside each other without sub-divisions, the clearance height within the carrier must be less than the line diameter. This is the only way of preventing the cables from twisting.

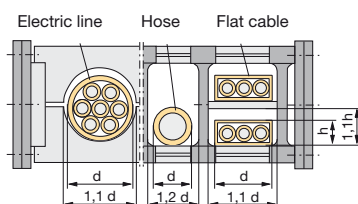

The supply cables must be free to move within the cable carrier. They cannot be fixed to the cable carrier or tied together. **Separating strips** must always be inserted between flat cables routed in multiple layers.

Recommended dimensions of the space required:

- for round cables: approx. 10 % of the line diameter
- with flat cables: for each, approx. 10 % of the cable width and cable thickness
- with hose lines: approx. 20 % of the hose diameter

Thin highflex cables with a low bending strength must be bundled and inserted into a protective hose. The cross section of the protective hose must be much larger than the sum of the individual cable cross sections. For the calculation of the cross section you should assume a standard clearance of 10 % of the individual line diameter.

Load diagrams

Self-supporting length depending on the additional load

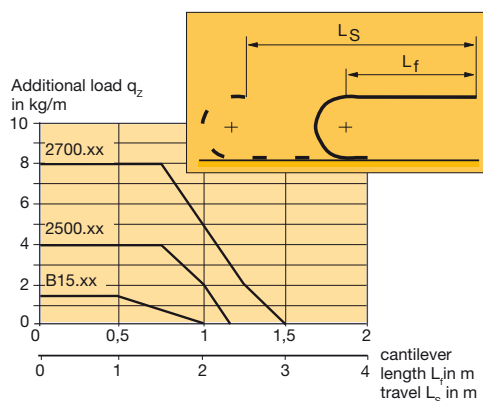

Length with permitted sag LD and travels

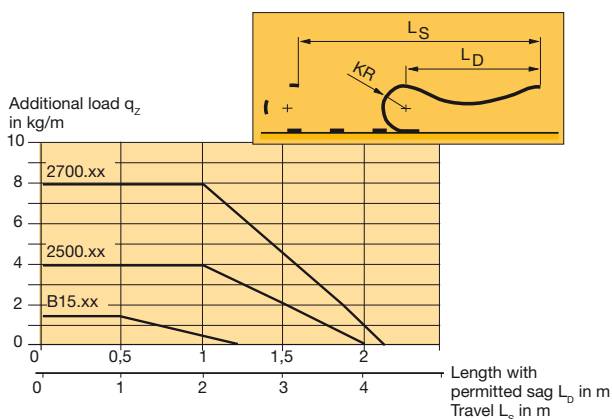

Determination of the chain length

$$L_k = \frac{S}{2} + K$$

Bending radius KR	K					Round LK to pitch t
	38	55	100	150	200	
B15.xx	185	--	--	--	--	30.5
2500.xx	--	276	414	578	--	46
2700.xx	--	--	--	--	825	56

Additional Accessories / Software

Belt tension measuring device RSM:

For accurately setting the toothed belt tension. (Art. No.: 037-000201)



DimAxes:

Dimensioning software for EME linear modules HPLA, HLE, HZR, HTR, BLMA - for PCs as from Windows version 95



Free download of the DimAxes Software or CAD files, catalogs and manuals, partly in different languages on:
www.parker-eme.com/hpla

Drive Options

The drive mounting side left (L) or right (R) is defined looking from the tensioning station to the drive station.

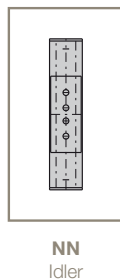
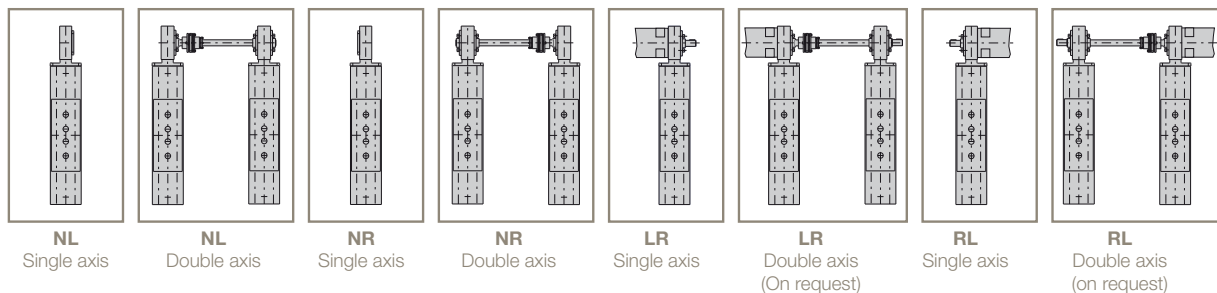
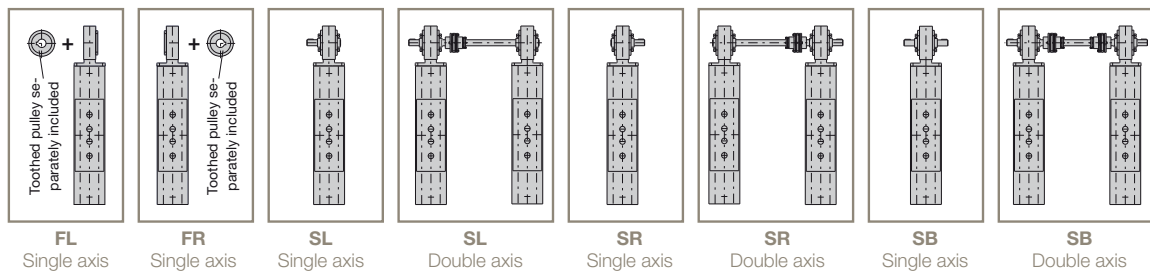

Additional Information available on:

www.parker-eme.com/hpla



WARNING – USER RESPONSIBILITY

FAILURE OR IMPROPER SELECTION OR IMPROPER USE OF THE PRODUCTS DESCRIBED HEREIN OR RELATED ITEMS CAN CAUSE DEATH, PERSONAL INJURY AND PROPERTY DAMAGE.

- This document and other information from Parker-Hannifin Corporation, its subsidiaries and authorized distributors provide product or system options for further investigation by users having technical expertise.
- The user, through its own analysis and testing, is solely responsible for making the final selection of the system and components and assuring that all performance, endurance, maintenance, safety and warning requirements of the application are met. The user must analyze all aspects of the application, follow applicable industry standards, and follow the information concerning the product in the current product catalog and in any other materials provided from Parker or its subsidiaries or authorized distributors.
- To the extent that Parker or its subsidiaries or authorized distributors provide component or system options based upon data or specifications provided by the user, the user is responsible for determining that such data and specifications are suitable and sufficient for all applications and reasonably foreseeable uses of the components or systems.

Parker Worldwide

AE – UAE, Dubai
Tel: +971 4 8127100
parker.me@parker.com

AR – Argentina, Buenos Aires
Tel: +54 3327 44 4129

AT – Austria, Wiener Neustadt
Tel: +43 (0)2622 23501-0
parker.austria@parker.com

AT – Eastern Europe,
Wiener Neustadt
Tel: +43 (0)2622 23501 900
parker.easteurope@parker.com

AU – Australia, Castle Hill
Tel: +61 (0)2-9634 7777

AZ – Azerbaijan, Baku
Tel: +994 50 2233 458
parker.azerbaijan@parker.com

BE/LU – Belgium, Nivelles
Tel: +32 (0)67 280 900
parker.belgium@parker.com

BR – Brazil, Cachoeirinha RS
Tel: +55 51 3470 9144

BY – Belarus, Minsk
Tel: +375 17 209 9399
parker.belarus@parker.com

CA – Canada, Milton, Ontario
Tel: +1 905 693 3000

CH – Switzerland, Etoy
Tel: +41 (0) 21 821 02 30
parker.switzerland@parker.com

CL – Chile, Santiago
Tel: +56 2 623 1216

CN – China, Shanghai
Tel: +86 21 5031 2525

CZ – Czech Republic, Klecany
Tel: +420 284 083 111
parker.czechrepublic@parker.com

DE – Germany, Kaarst
Tel: +49 (0)2131 4016 0
parker.germany@parker.com

DK – Denmark, Ballerup
Tel: +45 43 56 04 00
parker.denmark@parker.com

ES – Spain, Madrid
Tel: +34 902 33 00 01
parker.spain@parker.com

FI – Finland, Vantaa
Tel: +358 (0)20 753 2500
parker.finland@parker.com

FR – France, Contamine s/Arve
Tel: +33 (0)4 50 25 80 25
parker.france@parker.com

GR – Greece, Athens
Tel: +30 210 933 6450
parker.greece@parker.com

HK – Hong Kong
Tel: +852 2428 8008

HU – Hungary, Budapest
Tel: +36 1 220 4155
parker.hungary@parker.com

IE – Ireland, Dublin
Tel: +353 (0)1 466 6370
parker.ireland@parker.com

IN – India, Mumbai
Tel: +91 22 6513 7081-85

IT – Italy, Corsico (MI)
Tel: +39 02 45 19 21
parker.italy@parker.com

JP – Japan, Tokyo
Tel: +(81) 3 6408 3901

KR – South Korea, Seoul
Tel: +82 2 559 0400

KZ – Kazakhstan, Almaty
Tel: +7 7272 505 800
parker.easteurope@parker.com

LV – Latvia, Riga
Tel: +371 6 745 2601
parker.latvia@parker.com

MX – Mexico, Apodaca
Tel: +52 81 8156 6000

MY – Malaysia, Shah Alam
Tel: +60 3 7849 0800

NL – The Netherlands,
Oldenzaal
Tel: +31 (0)541 585 000
parker.nl@parker.com

NO – Norway, Ski
Tel: +47 64 91 10 00
parker.norway@parker.com

NZ – New Zealand, Mt Wellington
Tel: +64 9 574 1744

PL – Poland, Warsaw
Tel: +48 (0)22 573 24 00
parker.poland@parker.com

PT – Portugal, Leca da Palmeira
Tel: +351 22 999 7360
parker.portugal@parker.com

RO – Romania, Bucharest
Tel: +40 21 252 1382
parker.romania@parker.com

RU – Russia, Moscow
Tel: +7 495 645-2156
parker.russia@parker.com

SE – Sweden, Spånga
Tel: +46 (0)8 59 79 50 00
parker.sweden@parker.com

SG – Singapore
Tel: +65 6887 6300

SK – Slovakia, Banská Bystrica
Tel: +421 484 162 252
parker.slovakia@parker.com

SL – Slovenia, Novo Mesto
Tel: +386 7 337 6650
parker.slovenia@parker.com

TH – Thailand, Bangkok
Tel: +662 717 8140

TR – Turkey, Istanbul
Tel: +90 216 4997081
parker.turkey@parker.com

TW – Taiwan, Taipei
Tel: +886 2 2298 8987

UA – Ukraine, Kiev
Tel: +380 44 494 2731
parker.ukraine@parker.com

UK – United Kingdom,
Warwick
Tel: +44 (0)1926 317 878
parker.uk@parker.com

US – USA, Cleveland
Tel: +1 216 896 3000

VE – Venezuela, Caracas
Tel: +58 212 238 5422

ZA – South Africa,
Kempton Park
Tel: +27 (0)11 961 0700
parker.southafrica@parker.com

European Product Information Centre
Free phone: 00 800 27 27 5374
(from AT, BE, CH, CZ, DE, DK, ES, FI, FR, IE,
IT, NL, NO, PL, PT, RU, SE, UK, ZA)

We reserve the right to make technical changes. The data correspond to the technical state at the time of printing.
© 2010 Parker Hannifin Corporation

192-580011N10

February 2010



Parker Hannifin GmbH
Electromechanical Automation
Robert-Bosch-Straße 22
D-77656 Offenburg, Germany
+49 (0)781 / 509-0
+49 (0)781 / 509-98176
sales.automation@parker.com
www.parker-eme.com

Ed. 2009-03-11