



## HMR – Linear Drive Driving the future.

aerospace  
climate control  
electromechanical  
filtration  
fluid & gas handling  
hydraulics  
pneumatics  
process control  
sealing & shielding



ENGINEERING YOUR SUCCESS.

# EL Sizing

The dimensioning program for electric linear drives

Download available at [www.parker-origa.com](http://www.parker-origa.com)

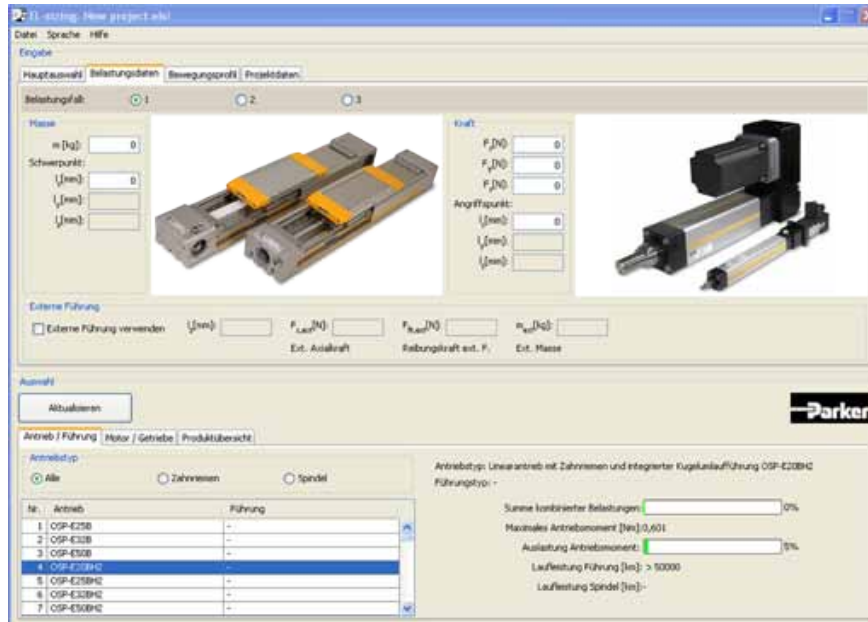

# ORIGA Linear Drives

*HMR Series*

<b>Table of Contents</b>	page
<b>Profile Version</b>	<b>6</b>
- Loads forces and bending moments	7
<b>Ball Screw</b>	<b>11</b>
- Drive Data	12
- Performance / Thrust Force	13
- Dimensions	15
- Weight, Mass, Inertia	17
- Order Stroke	18
- Order Code	20
<b>Belt</b>	<b>23</b>
- Drive Data	24
- Thrust Force	25
- Dimensions	26
- Weight, Mass, Inertia	28
- Order Stroke	29
- Order Code	30
<b>Options</b>	<b>33</b>
- Protection Class	34
- Impact Protection	35
- Position Detection	37
<b>Accessories</b>	<b>41</b>
- Coupling Housing	42
- Motor Coupling	43
- Mountings	44
- T-slot Fixture	45
<b>Drive Combinations</b>	<b>46</b>
- Ball Screw Drive	46
- Belt Drive	48

# ORIGA HMR Electromechanical Linear Actuators



## Profile designs

- Basic profile for assembling directly to the machine base
- Reinforced profile for self-supporting assembly



## Mounting systems

- Integrated T-slots for attaching from below and from the side



## Protection classes

- Without cover: Standard
- With cover: IP54



## Guide systems

- Plain bearing guide
- Recirculating ball bearing guide



## Lubrication

- Central lubrication via externally accessible lubricating nipples

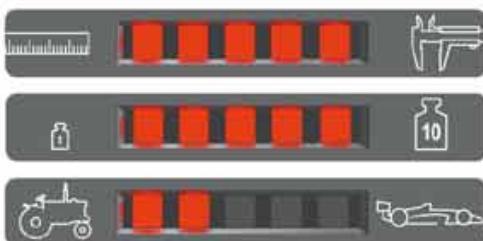
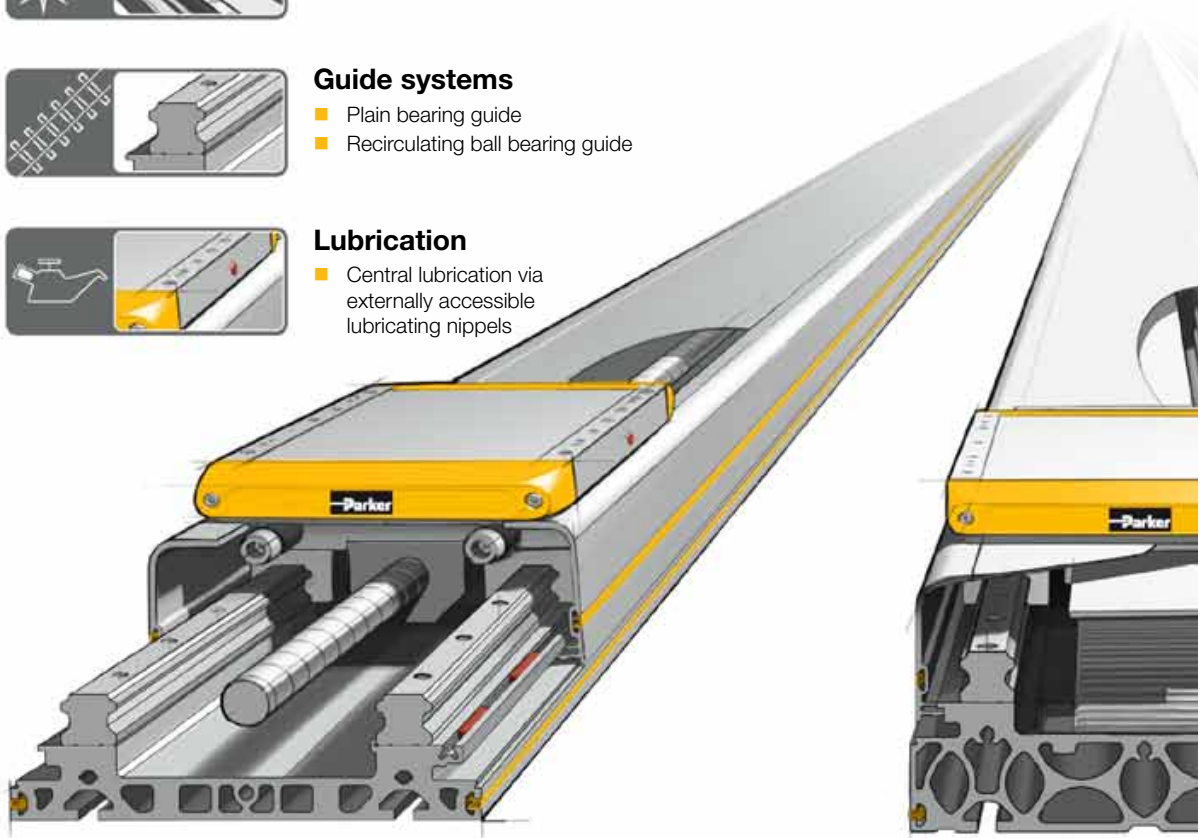

## Screw drive

The solution for precise path and position control for heavy loads

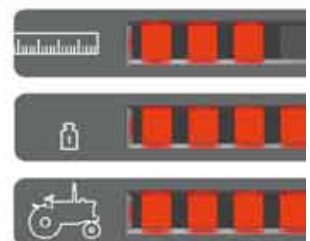

## Toothed belt drive

The solution for fast path and position control for medium loads

We drive the future - with screw or toothed belt.

### Position sensing

- Integrated, adjustable position switch for end positions and homing

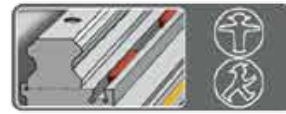

### Impact protection

- Integrated shock absorbers for both end positions



### Distance measurement

- Contact-free, incremental displacement measuring system



### Brake system

- Holding brake can be implemented for horizontal and vertical movements



### Cable drag chains

- Directly attachable drag chains for various cabling

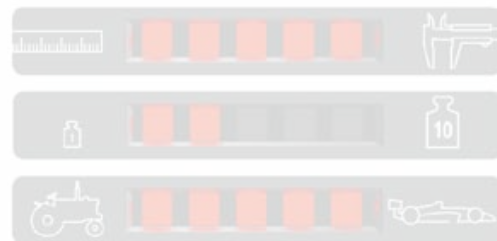
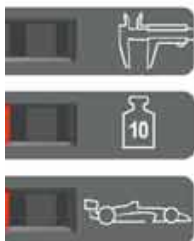
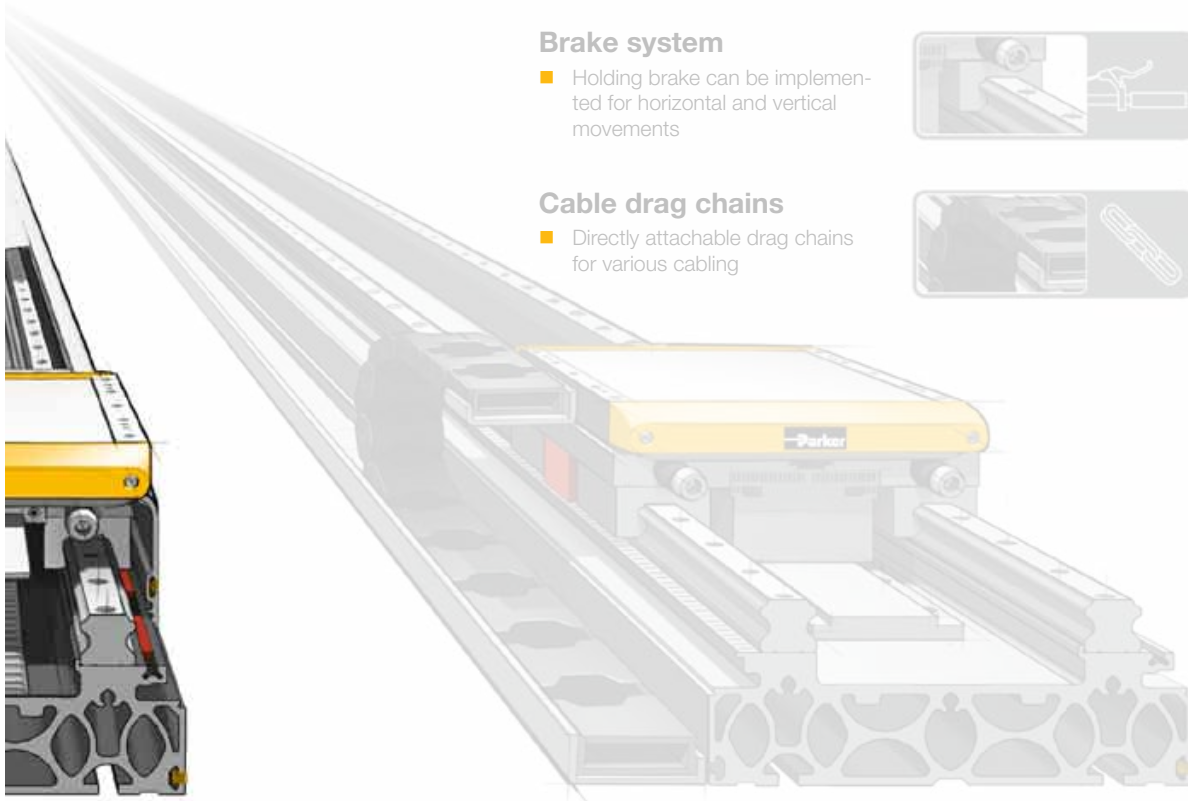

ads

### Linear drive (under work)

The solution for fast travel with the greatest possible dynamics and precision

## ORIGA Linear Drives

HMR Series

Profile Versions

Sizes 85, 110, 150, 180, 240 mm

### Designs

– Basic

– Reinforced

The HMR linear drive system can be equipped with a “basic” or “reinforced” profile as standard. The “basic” profile is suitable for fitting directly to a machine base that has a corresponding support surface. The “reinforced” profile, on the other hand, is the preferred choice for self-supporting systems or for use in conjunction with a base surface offering limited support. The permissible temperature range for both profile versions is -20°C ... +80°C.

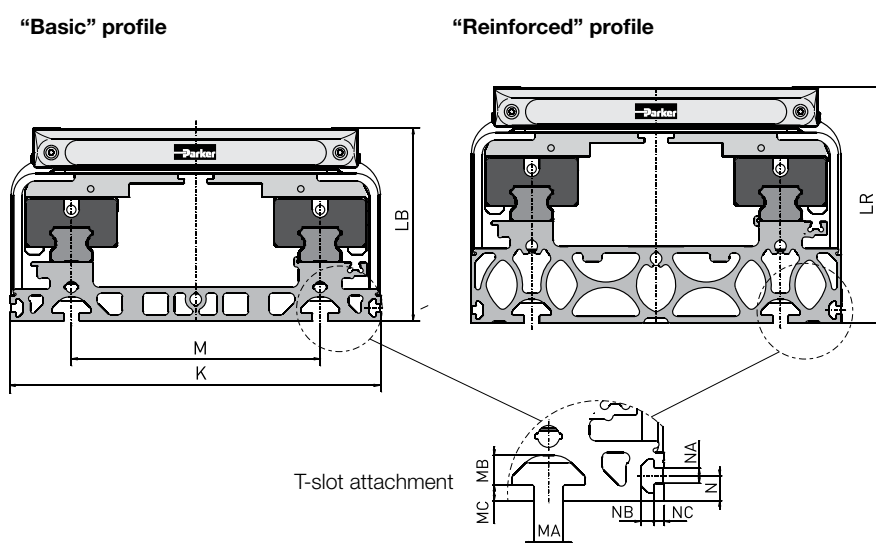

Dimensions - Profil design HMR

Product Size		K	LB	LR	M	MA	MB	MC	N	NA	NB	NC
HMRx085	[mm]	85.0	60.0	71.0	50.0	5.2	4.5	1.5	4.5	3.4	3.0	2.5
HMRx110	[mm]	110.0	69.5	89.5	70.0	5.2	4.5	1.8	4.5	3.4	3.0	2.5
HMRx150	[mm]	150.0	90.0	114.0	96.0	6.2	6.8	3.0	6.5	5.2	4.6	3.5
HMRx180	[mm]	180.0	111.5	134.5	116.0	8.0	7.8	4.5	8.5	5.2	4.5	3.5
HMRx240	[mm]	240.0	125.0	153.0	161.0	10.0	10.2	5.3	8.5	5.2	4.5	3.5

## ORIGA Linear Drives

HMR Series  
 Profile version „reinforced“  
 Sizes 85, 110, 150, 180, 240 mm

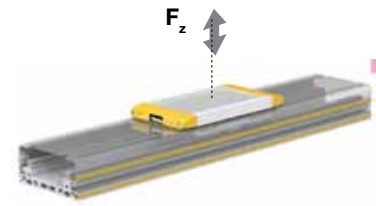

Max. admissible loads [N] and supporting distances [mm] (self-supporting)

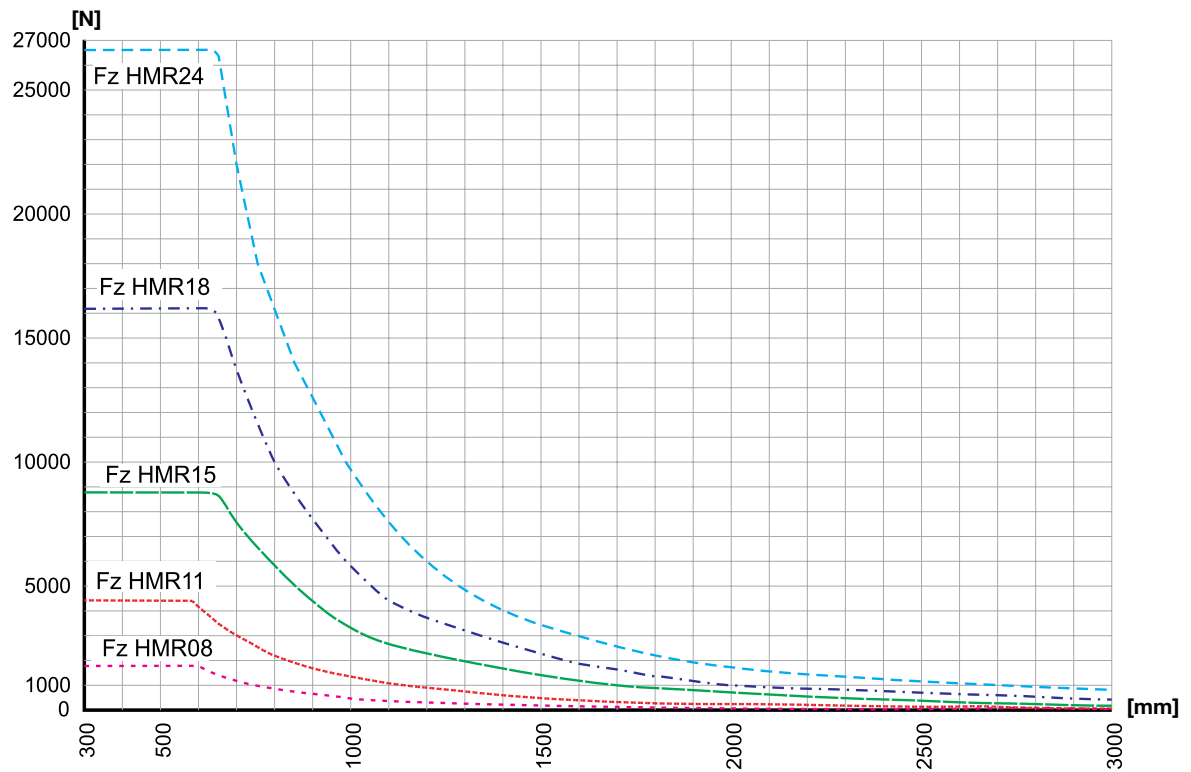

### Example $F_z$ HMR 11:

For a 2.800 N load the distance „D“ between supporting elements is 720 mm.  
 Mounting accessories see „Accessories / T-Slot Mounting“

## ORIGA Linear Drives

HMR series

Profile version „reinforced“

Sizes 85, 110, 150, 180, 240 mm



Max. admissible loads [N] and supporting distances [mm] (self-supporting)

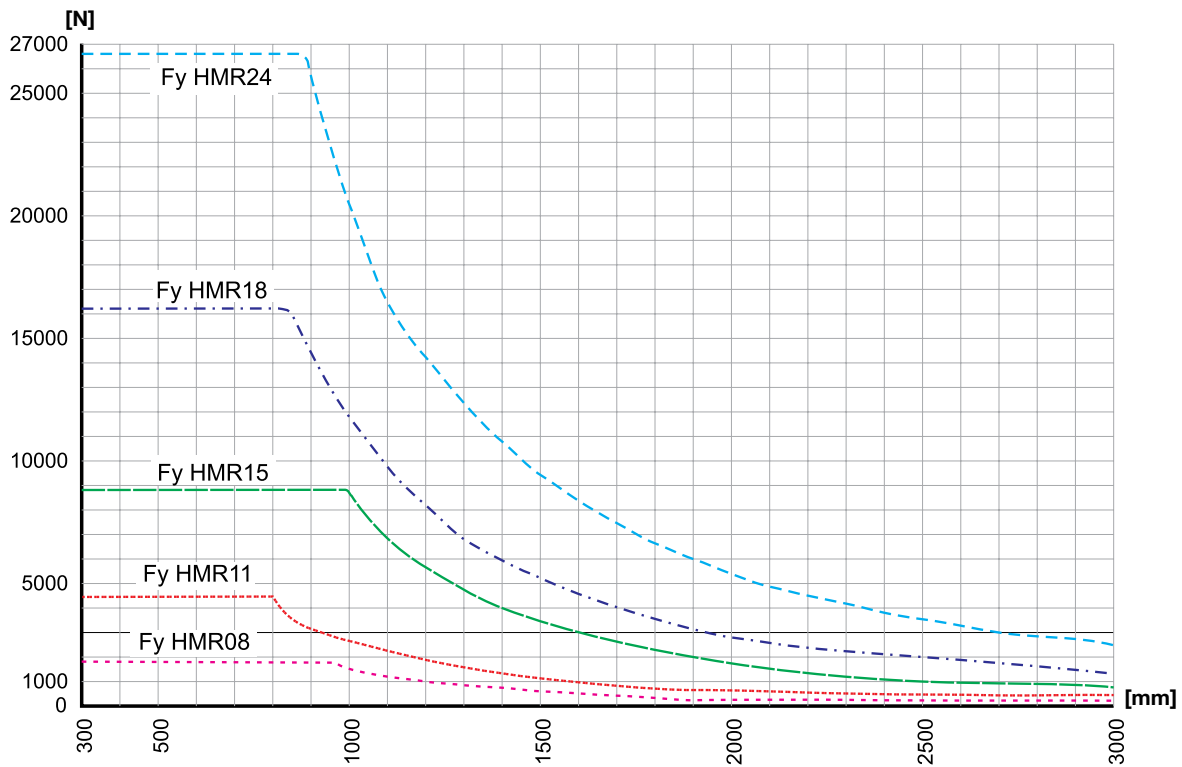

### Example $F_y$ HMR 11:

For a 3.160 N load the distance „D“ between supporting elements is 900 mm.  
Mounting accessories see „Accessories / T-Slot Mounting“

## ORIGA Linear Drives

HMR series

Ball bearing guide

Sizes 85, 110, 150, 180, 240 mm

### Load requirements for guides and installation size.

The occurring loads, forces and bending moments depend on the application. The mass of the construction attached to the carriage has a center of gravity. This mass creates static forces ( $F = m \cdot g$ ) and bending moments ( $M = m \cdot g \cdot l$ ). Additional dynamic moments ( $M = m \cdot a \cdot l$ ) arise in dependence of the acceleration during travel. Care should be taken when selecting suitable guides that the permissible sum of loads does not exceed 1.

### Loads, forces and bending moments

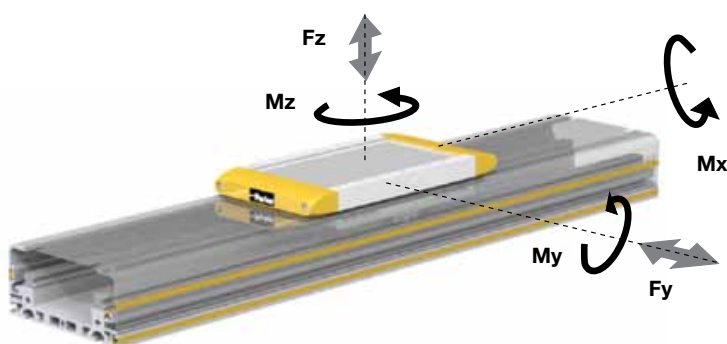

Internal lever arm  $l_{zi}$

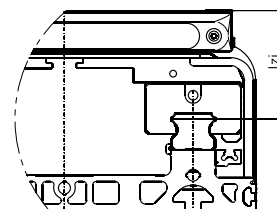

Dimensions - Internal lever arm  $l_{zi}$

Product size		$l_{zi}$
HMRx085	[mm]	33.0
HMRx110	[mm]	39.5
HMRx150	[mm]	50.0
HMRx180	[mm]	57.5
HMRx240	[mm]	68.0

### Combined loads

The maximum permissible load for linear drives subject to simultaneous multiple

loads, forces and bending moments are calculated using the formula below.

$$L = \frac{F_y}{F_{y(max)}} + \frac{F_z}{F_{z(max)}} + \frac{M_x}{M_{x(max)}} + \frac{M_y}{M_{y(max)}} + \frac{M_z}{M_{z(max)}} \leq 1$$

Maximum permissible loads must not be exceeded.

The sum of all loads must under no circumstance be  $> 1$ .

**Maximum permissible loads based on a performance of 2,540 km**

Product Size	HMRx08	HMRx11	HMRx15	HMRx18	HMRx24	HMRx08	HMRx11	HMRx15	HMRx18	HMRx24	
Carriage	Standard					Tandem					
<b>Max. permissible load</b>											
$F_{z2540}$ $F_{y2540}$	[N]	1,800	4,450	8,800	16,200	26,600	2,700	6,700	13,200	24,300	39,900
<b>Max. permissible bending moment</b>											
$M_{x2540}$	[Nm]	45	155	430	940	2,150	68	235	645	1,410	3,225
$M_{y2540}$ $M_{z2540}$	[Nm]	80	200	560	1,230	2,430	120	300	840	1,845	3,645

**Maximum permissible loads based on a performance of 8,000 km**

Product Size	HMRx08	HMRx11	HMRx15	HMRx18	HMRx24	HMRx08	HMRx11	HMRx15	HMRx18	HMRx24	
Carriage	Standard					Tandem					
<b>Max. permissible load</b>											
$F_{z8000}$ $F_{y8000}$	[N]	1,250	3,000	6,000	11,000	18,200	1,875	4,500	9,000	16,500	27,300
<b>Max. permissible bending moment</b>											
$M_{x8000}$	[Nm]	30	105	290	640	1,460	45	160	435	960	2,190
$M_{y8000}$ $M_{z8000}$	[Nm]	55	135	380	840	1,660	80	205	570	1,260	2,490

# HMRS Ball Screw



## ORIGA Linear Drives

Series HMRS / Ball Screw / Drive Data / Sizes 85, 110, 150, 180, 240 mm

### Technical Data HMRS

Product Size			HMRS08		HMRS11		HMRS15		HMRS18		HMRS24	
Type of Screw			12 x 5	12 x 12	16 x 5	16 x 16	20 x 5	20 x 20	25 x 10	25 x 25	32 x 10	32 x 32
Pitch	p	[mm]	5	12	5	16	5	20	10	25	10	32
Max. speed	$v_{max}$	[m/s]	0.25	0.60	0.25	0.80	0.25	1.00	0.50	1.25	0.50	1.60
Max. acceleration	$a_{max}$	[m/s <sup>2</sup> ]	10		10		10		10		10	
Repeatability		[ $\mu$ m]	$\pm 20$		$\pm 20$		$\pm 20$		$\pm 20$		$\pm 20$	
Max. stroke		[mm]	1,200		1,500		2,500		3,400		4,000	
Thrust force and torque												
Max. thrust force	$F_{Amax}$	[N]	820	820	2,200	2,200	2,600	2,600	4,800	4,800	5,500	5,500
	$F_{A2540}$	[N]	820	650	1,550	1,150	1,800	2,160	3,300	3,960	3,500	4,880
Max. torque at drive shaft	$M_{Amax}$	[Nm]	0.7	1.7	1.9	6.1	2.2	9.0	8.3	20.8	9.5	30.4
	$M_{A2540}$	[Nm]	0.7	1.3	1.3	3.1	1.6	7.5	5.7	17.1	6.1	27.0
No load torque	$M_0$	[Nm]	0.2	0.2	0.3	0.4	0.7	0.9	0.9	1.0	1.0	1.1
Stroke dependent speed												
Max. permissible speed at order stroke	200	[mm]	250	600	250	800	250	1,000	500	1,250	500	1,600
	400	[mm]	250	600	250	800	250	1,000	500	1,250	500	1,600
	600	[mm]	152	366	197	631	250	1,000	500	1,250	500	1,600
	800	[mm]	102	245	132	424	169	678	382	956	423	1,354
	1000	[mm]	73	176	95	304	122	486	277	694	312	997
	1200	[mm]	55	132	71	228	91	366	211	526	239	765
	1400	[mm]	-	-	56	178	71	285	165	413	189	605
	1600	[mm]	-	-	45	143	57	228	133	333	153	491
	1800	[mm]	-	-	-	-	47	187	109	274	127	406
	2000	[mm]	-	-	-	-	39	156	92	229	107	342
	2200	[mm]	-	-	-	-	33	132	78	195	91	291
	2400	[mm]	-	-	-	-	28	113	67	167	79	251
	2600	[mm]	-	-	-	-	-	-	58	145	68	219
	2800	[mm]	-	-	-	-	-	-	51	128	60	193
	3000	[mm]	-	-	-	-	-	-	45	113	53	171
	3200	[mm]	-	-	-	-	-	-	40	100	48	152
	3400	[mm]	-	-	-	-	-	-	-	-	43	137
3600	[mm]	-	-	-	-	-	-	-	-	39	123	
3800	[mm]	-	-	-	-	-	-	-	-	35	112	
4000	[mm]	-	-	-	-	-	-	-	-	32	102	



## ORIGA Linear Drives

Series HMRS / Ball Screw / Performance / Thrust Force Sizes 85, 110, 150, 180, 240 mm

Performance expectancy depends on the application's required force. An increase in force will reduce performance.

**HMRS08 Performance / Thrust force**

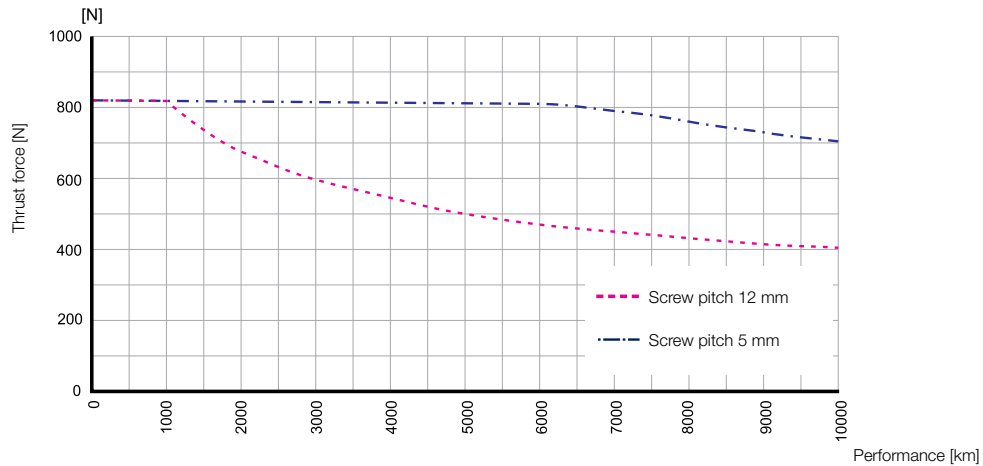

**HMRS11 Performance / Thrust force**

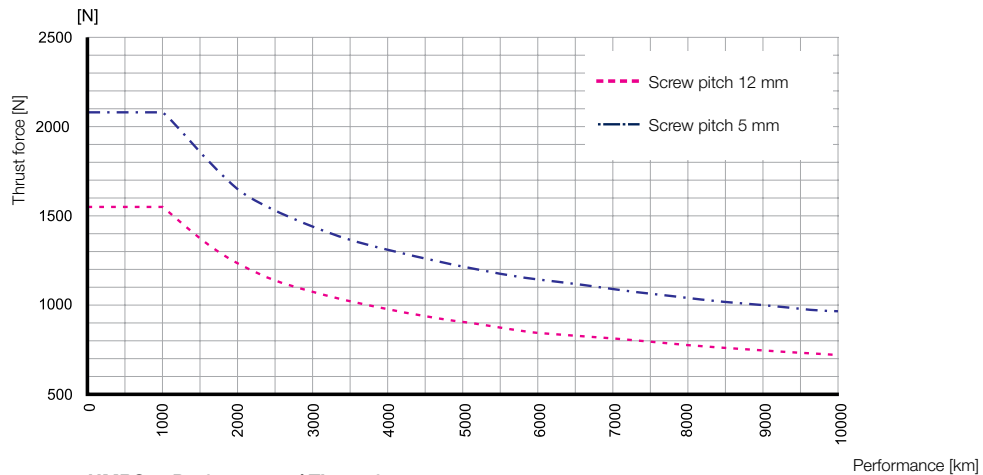

**HMRS15 Performance / Thrust force**

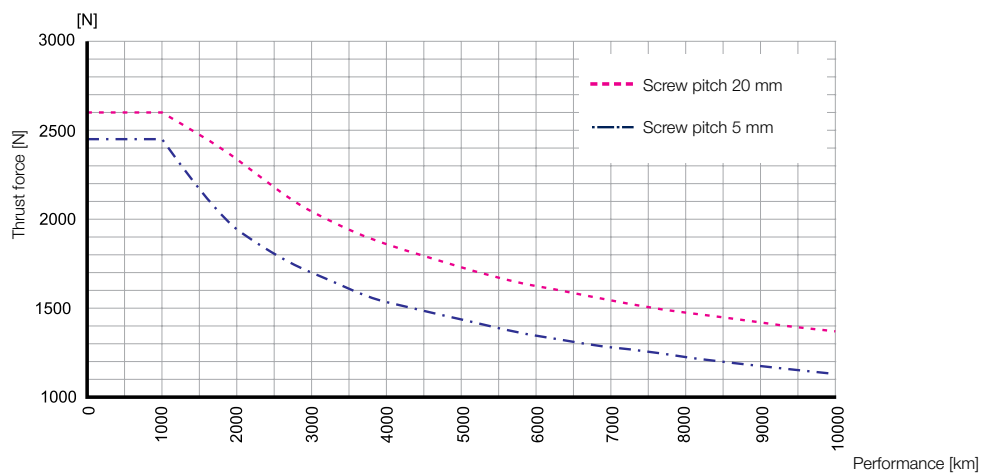

**HMRS18 Performance / Thrust force**

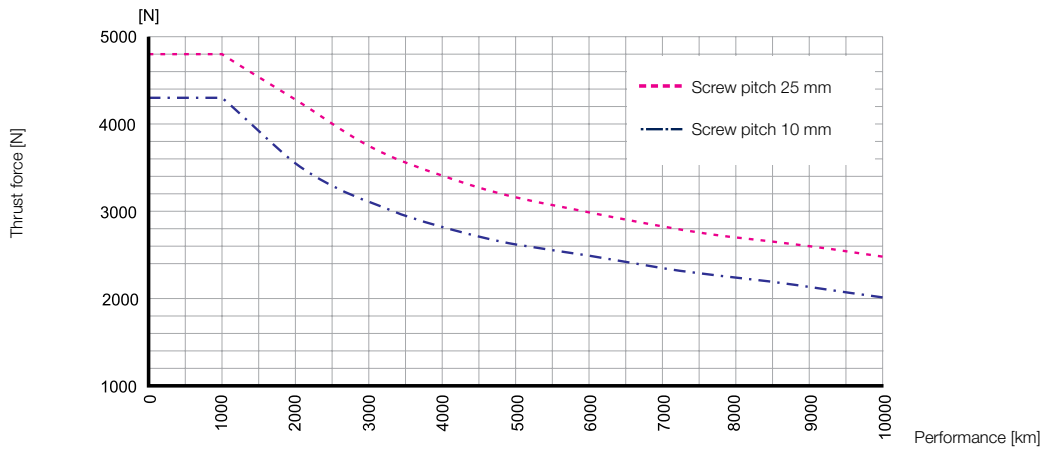

**HMRS24 Performance / Thrust force**

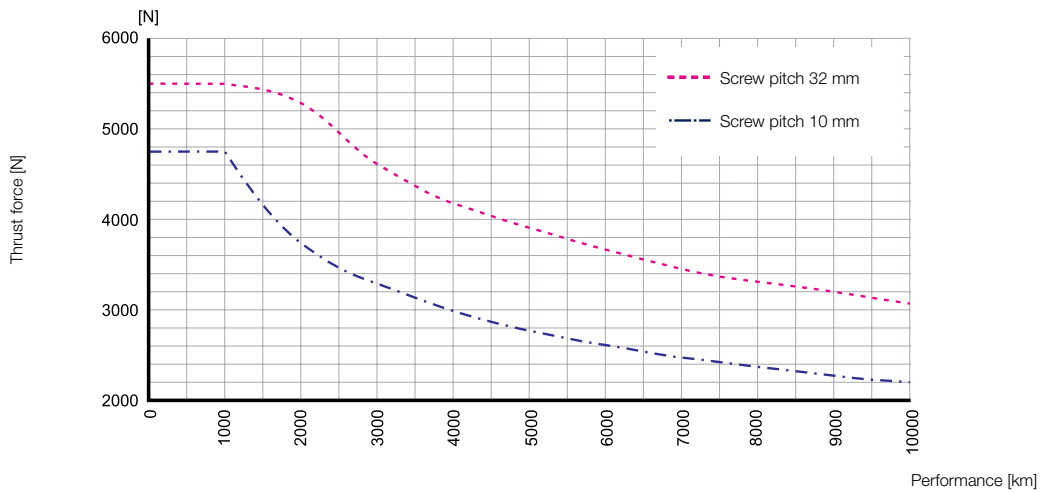

# ORIGA Linear Drives

Series HMRS / Ball screw / Dimensions / Sizes 85, 110, 150, 180, 240 mm

## Basic dimensions

### "Basic" profile

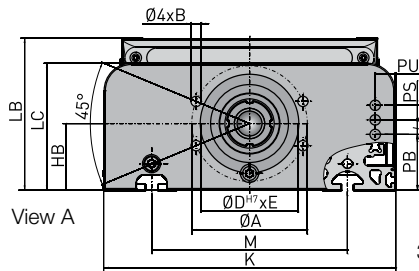

### "Reinforced" profile

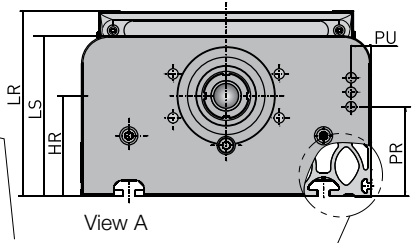

3-PIN M8 connections

T-slot attachment

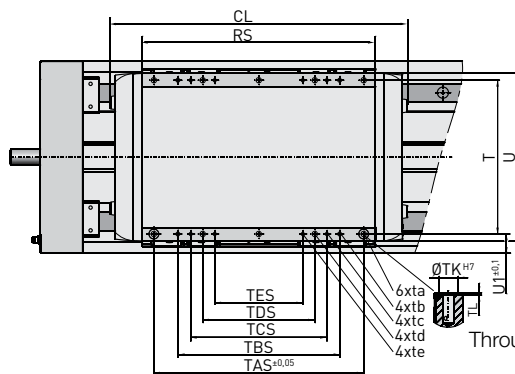
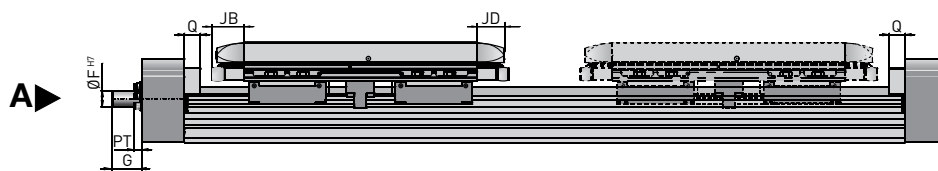
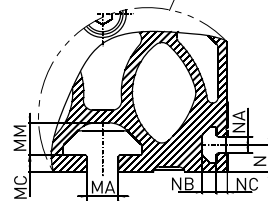

Carriage dimensions

Through-hole attachment

## ORIGA Linear Drives

Series HMRS / Ball screw / Dimensions / Sizes 85, 110, 150, 180, 240 mm

Dimension table - HMRS

Prod.size	ØA	B	ØD <sup>H7</sup>	E	ØF <sup>H7</sup>	G	HB	HR	K	LB	LC	LR	LS
HMRS08 [mm]	42.0	M4	34.0	3.0	6.0	11.0	26.0	37.0	85.0	60.0	52.5	71.0	63.5
HMRS11 [mm]	51.0	M6	39.0	5.0	10.0	18.0	32.0	52.0	110.0	69.5	60.5	89.5	80.5
HMRS15 [mm]	72.0	M8	54.0	4.0	12.0	31.0	36.0	60.0	150.0	90.0	74.0	114.0	98.0
HMRS18 [mm]	80.0	M8	64.0	2.5	15.0	33.0	44.0	67.5	180.0	111.5	93.5	134.5	116.5
HMRS24 [mm]	95.0	M10	80.0	2.5	20.0	37.0	55.0	83.0	240.0	125.0	104.5	153.0	132.5

Dimension table - HMRS

Prod.size	M	MA	MB	MC	N	NA	NB	NC	PB	PR	PS	PT	PU	Q
HMRS08 [mm]	50.0	5.2	4.5	1.5	4.5	3.4	3.0	2.5	19.3	30.3	12.0	9.0	7.1	16.0
HMRS11 [mm]	70.0	5.2	4.5	1.8	4.5	3.4	3.0	2.5	23.5	43.5	12.0	9.0	8.5	20.0
HMRS15 [mm]	96.0	6.2	6.8	3.0	6.5	5.2	4.6	3.5	15.0	39.0	12.0	9.0	15.0	20.0
HMRS18 [mm]	116.0	8.0	7.8	4.5	8.5	5.2	4.5	3.5	28.0	51.0	12.0	9.0	18.0	20.0
HMRS24 [mm]	161.0	10.0	10.2	5.3	8.5	5.2	4.5	3.5	46.0	74.0	12.0	9.0	16.5	20.0

Dimension table - carriage standard HMRS

Prod.size	JB	JD	CL	RS	T	TAS	ta	TBS	tb	TCS	tc	TDS	td	TES
HMRS08 [mm]	33.5	30.0	195.0	128.0	74.0	97.0	M4x12	70.0	M4x12	40.0	M4x12	-	-	-
HMRS11 [mm]	37.5	34.0	225.0	150.0	96.0	122.0	M5x12	97.0	M5x12	65.0	M5x12	25.0	M5x12	-
HMRS15 [mm]	37.5	34.0	266.0	191.0	120.0	170.0	M5x12	122.0	M5x12	-	-	70.0	M5x12	-
HMRS18 [mm]	40.0	34.0	311.0	231.0	150.0	202.0	M6x12	170.0	M5x10	122.0	M5x10	90.0	M6x12	-
HMRS24 [mm]	40.0	34.0	371.0	291.0	192.0	262.0	M8x16	202.0	M6x12	170.0	M5x10	140.0	M8x16	122.0

Dimension table - carriage standard HMRS

Prod.size	te	ØTKH7	TL	U	U1
HMRS08 [mm]	-	7.0	1.5	83.0	5.5
HMRS11 [mm]	-	7.0	1.5	105.0	7.0
HMRS15 [mm]	-	7.0	1.5	135.0	15.0
HMRS18 [mm]	-	9.0	1.5	165.0	15.0
HMRS24 [mm]	M5x10	12.0	1.5	210.0	24.0

## ORIGA Linear Drives

Series HMRS / Weight, mass and inertia

### Weight and mass HMRS

Product size			HMRS08				HMRS11				HMRS15			
<b>Weight of actuator</b>														
<b>Version of actuator</b> (see order code)			B	C	R	S	B	C	R	S	B	C	R	S
Weight actuator. 0 - order stroke	$m_0$	[kg]	1.8	2.1	2.2	2.5	3.5	3.9	4.6	5.0	5.2	6.1	7.1	7.9
Weight actuator per 1 meter	$m_{mt}$	[kg/m]	3.7	4.7	4.8	5.7	6.6	7.6	8.8	9.9	12.1	13.9	15.5	17.2
<b>Moving mass</b>														
<b>Version of carriage</b> (see order code)			0	1	0	1	0	1	0	1	0	1	0	1
Weight actuator	$m_c$	[kg]	1.0	0.7	1.6	1.3	2.6	1.8						

### Weight and mass HMRS

Product size			HMRS18				HMRS24			
<b>Weight of actuator</b>										
<b>Version of actuator</b> (see order code)			B	C	R	S	B	C	R	S
Weight actuator. 0 - order stroke	$m_0$	[kg]	8.9	10.0	11.2	12.3	16.5	18.1	20.5	22.2
Weight actuator per 1 meter	$m_{mt}$	[kg/m]	15.5	17.7	19.1	21.4	25.6	28.3	30.7	33.4
<b>Moving mass</b>										
<b>Version of carriage</b> (see order code)			0	1	0	1				
Weight actuator	$m_c$	[kg]	4.7	3.7	9.2	7.3				

Total mass HMRS:  $m_{tot} = m_0 + m_c + \text{order stroke} * m_{mt}$

### Inertia HMRS

Product size			HMRS08		HMRS11		HMRS15	
<b>Pitch</b> (see order code)			<b>5</b>	<b>12</b>	<b>5</b>	<b>16</b>	<b>5</b>	<b>20</b>
Inertia actuator. 0 - order stroke	$J_0$	[kgmm <sup>2</sup> ]	4		13		14	
Inertia actuator per 1 meter	$J_{mt}$	[kgmm <sup>2</sup> /m]	14		45		107	
Inertia per 1 kg moving mass	$J_{kg}$	[kgmm <sup>2</sup> /kg]	0.6	3.7	0.6	6.5	0.6	10.1

### Inertia HMRS

Product size			HMRS18		HMRS24	
<b>Pitch</b> (see order code)			<b>10</b>	<b>25</b>	<b>10</b>	<b>32</b>
Inertia actuator. 0 - order stroke	$J_0$	[kgmm <sup>2</sup> ]	35		96	
Inertia actuator per 1 meter	$J_{mt}$	[kgmm <sup>2</sup> /m]	245		639	
Inertia per 1 kg moving mass	$J_{kg}$	[kgmm <sup>2</sup> /kg]	2.5	15.8	2.5	25.9

Total inertia HMRS:  $J_{tot} = J_0 + \text{order stroke} * J_{mt} + m_c * J_{kg} + m * J_{kg}$

## ORIGA Linear Drives

Series HMRS / Ball screw / Order stroke / Sizes 85, 110, 150, 180, 240 mm

### Order stroke dependent dimensions

- ES = Effective Stroke
- SS = Safety Stroke
- CD = Carriage distance
- CL = Carriage length Standard
- S = Stroke
- OS = Order Stroke
- OAL = Over All Length

### Standard design with one carriage

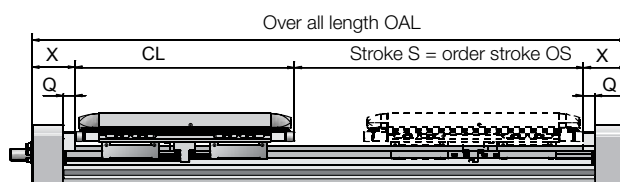

Order stroke OS = Effective stroke ES + 2 x Safety stroke SS  
 Over all length OAL = order stroke OS + carrier length CL + 2 x dimension end cap X

### Tandem design with two carriages

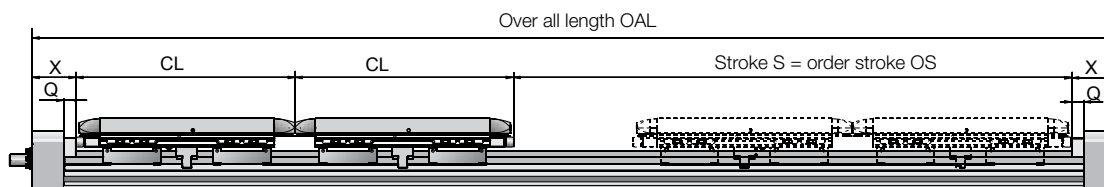

Order stroke OS = Effective stroke ES + 2 x Safety stroke SS + Carrier distance CD (not shown)  
 Over all length OAL = Order stroke OS + 2 x carriage length CL + 2 x dimension end cap X

### Dimensions - Carriage and end cap HMRS

Product size		CL	Q	X
HMRS08	[mm]	195.0	16.0	54.0
HMRS11	[mm]	225.0	20.0	65.0
HMRS15	[mm]	266.0	20.0	62.0
HMRS18	[mm]	311.0	20.0	66.0
HMRS24	[mm]	371.0	20.0	73.0





# ORIGA Linear Drives

Series HMRS

**Order code** HMR S 15 B 05 0 - 0000 - 0 0 0 0 0 00 00

↑ ↑ ↑ ↑ ↑ ↑ ↑ ↑ ↑ ↑ ↑ ↑

**Type of actuator**

S	Ball screw drive
---	------------------

**Product size**

08	Product width 085 mm
11	Product width 110 mm
15	Product width 150 mm
18	Product width 180 mm
24	Product width 240 mm

**Actuator design**

B	Basic Profile with ball bearing guide Standard
C	Basic Profile with ball bearing guide and IP54 with outer cover
R	Reinforced Profile with ball bearing guide Standard
S	Reinforced Profile with ball bearing guide and IP54 with outer cover

**Pitch**

Product size HMRS	08	11	15	18	24
05 Pitch 5 mm with plane drive shaft	<input checked="" type="checkbox"/>	<input checked="" type="checkbox"/>	<input checked="" type="checkbox"/>		
10 Pitch 10 mm with plane drive shaft				<input checked="" type="checkbox"/>	<input checked="" type="checkbox"/>
12 Pitch 12 mm with plane drive shaft	<input checked="" type="checkbox"/>				
16 Pitch 16 mm with plane drive shaft		<input checked="" type="checkbox"/>			
20 Pitch 20 mm with plane drive shaft			<input checked="" type="checkbox"/>		
25 Pitch 25 mm with plane drive shaft				<input checked="" type="checkbox"/>	
32 Pitch 32 mm with plane drive shaft					<input checked="" type="checkbox"/>

**Carriage**

0	Standard
1	Tandem

**Order stroke**

0000 4 digits input in mm

**Home sensor (one switch)**

0	Without
1	R2NO-I: Reed, 2 wire, NO, internal
A	P3NO-I: PNP, 3 wire, NO, internal
K	N3NO-I: NPN, 3 wire, NO, internal
3	R2NO-P: Reed, 2 wire, NO, M8 plug, 0.3 m cable, external
C	P3NO-P: PNP, 3-wire, NO, M8 plug, 0.3 m cable, external
M	N3NO-P: NPN, 3-wire, NO, M8 plug, 0.3 m cable, external
5	R2NO-FL3: Reed, 2 wire, NO, flying leads, 3 m cable, external
E	P3NO-FL3: PNP, 3 wire, NO, flying leads, 3 m cable, external
P	N3NO-FL3: NPN, 3 wire, NO, flying leads, 3 m cable, external
7	R2NO-FL10: Reed, 2 wire, NO, flying leads, 10 m cable, external
G	P3NO-FL10: PNP, 3 wire, NO, flying leads, 10 m cable, external
R	N3NO-FL10: NPN, 3 wire, NO, flying leads, 10 m cable, external

**Limit sensor (one switch per end position)**

0	Without
2	R2NC-I: Reed, 2 wire, NC, internal
B	P3NC-I: PNP, 3 wire, NC, internal
L	N3NC-I: NPN, 3 wire, NC, internal
4	R2NC-P: Reed, 2 wire, NC, M8 plug, 0.3 m cable, external
D	P3NC-P: PNP, 3 wire, NC, M8 plug, 0.3 m cable, external
N	P3NC-P: PNP, 3 wire, NC, M8 plug, 0.3 m cable, external
6	R2NC-FL3: Reed, 2 wire, NC, flying leads, 3 m cable, external
F	P3NC-FL3: PNP, 3 wire, NC, flying leads, 3 m cable, external
Q	N3NC-FL3: NPN, 3 wire, NC, flying leads, 3 m cable, external
8	R2NC-FL10: Reed, 2 wire, NC, flying leads, 10 m cable, external
H	P3NC-FL10: PNP, 3 wire, NC, flying leads, 10 m cable, external
S	N3NC-FL10: NPN, 3 wire, NC, flying leads, 10 m cable, external



### Mounting kits\*

Product size HMRS		08	11	15	18	24							
00	Without mounting kit or motor mounting	<input checked="" type="checkbox"/>	<input checked="" type="checkbox"/>	<input checked="" type="checkbox"/>	<input checked="" type="checkbox"/>	<input checked="" type="checkbox"/>							
<b>Gear mounting kit</b>													
A7	PS60			<input checked="" type="checkbox"/>	<input checked="" type="checkbox"/>								
A8	PS90				<input checked="" type="checkbox"/>								
A9	PS115					<input checked="" type="checkbox"/>							
C0	LP050	<input checked="" type="checkbox"/>	<input checked="" type="checkbox"/>										
C1	PV60-TA / LP070		<input checked="" type="checkbox"/>	<input checked="" type="checkbox"/>	<input checked="" type="checkbox"/>								
C2	PV90-TA / LP090				<input checked="" type="checkbox"/>								
C3	PV115-TA / LP120					<input checked="" type="checkbox"/>							
<b>Mounting kit motor</b>													
Size gear mounting		08	11	15	18	24	Ax	Bx	Cx	Dx	Fx	Gx	Hx
A2	SMx60 8/11, MH56 5/11, NX2	<input checked="" type="checkbox"/>	<input checked="" type="checkbox"/>	<input checked="" type="checkbox"/>			<input checked="" type="checkbox"/>	<input checked="" type="checkbox"/>			<input checked="" type="checkbox"/>		
A3	SMx82 8/14		<input checked="" type="checkbox"/>	<input checked="" type="checkbox"/>	<input checked="" type="checkbox"/>			<input checked="" type="checkbox"/>	<input checked="" type="checkbox"/>		<input checked="" type="checkbox"/>	<input checked="" type="checkbox"/>	<input checked="" type="checkbox"/>
A4	SMx100 5/19, MH105 5/19			<input checked="" type="checkbox"/>	<input checked="" type="checkbox"/>	<input checked="" type="checkbox"/>			<input checked="" type="checkbox"/>	<input checked="" type="checkbox"/>		<input checked="" type="checkbox"/>	<input checked="" type="checkbox"/>
A5	SMx115 5/24, SMx142 5/24, MH145 5/24				<input checked="" type="checkbox"/>	<input checked="" type="checkbox"/>			<input checked="" type="checkbox"/>	<input checked="" type="checkbox"/>			<input checked="" type="checkbox"/>
AG	SMx60 5/11, MH70 5/11, NX3	<input checked="" type="checkbox"/>	<input checked="" type="checkbox"/>				<input checked="" type="checkbox"/>	<input checked="" type="checkbox"/>			<input checked="" type="checkbox"/>		
AL	MPP092				<input checked="" type="checkbox"/>			<input checked="" type="checkbox"/>	<input checked="" type="checkbox"/>				
AK	AK - SMx115 7/24, MH105 9/24, NX6								<input checked="" type="checkbox"/>	<input checked="" type="checkbox"/>			<input checked="" type="checkbox"/>
AJ	SMx82 8/19, MH105 7/19, NX4								<input checked="" type="checkbox"/>	<input checked="" type="checkbox"/>		<input checked="" type="checkbox"/>	
AH	SMx60 8/9, MH56 5/9	<input checked="" type="checkbox"/>	<input checked="" type="checkbox"/>				<input checked="" type="checkbox"/>	<input checked="" type="checkbox"/>			<input checked="" type="checkbox"/>		
B0	motor mounting kit (75 / M6 / 60 / 3 / 14 / 30)	<input checked="" type="checkbox"/>						<input checked="" type="checkbox"/>	<input checked="" type="checkbox"/>				
B1	motor mounting kit (90 / M5 / 60 / 3 / 11 / 23)	<input checked="" type="checkbox"/>	<input checked="" type="checkbox"/>				<input checked="" type="checkbox"/>	<input checked="" type="checkbox"/>					
B2	motor mounting kit (90 / M5 / 60 / 3 / 14 / 30)	<input checked="" type="checkbox"/>	<input checked="" type="checkbox"/>					<input checked="" type="checkbox"/>	<input checked="" type="checkbox"/>				
B3	motor mounting kit (95 / M6 / 50 / 3 / 14 / 30)	<input checked="" type="checkbox"/>	<input checked="" type="checkbox"/>					<input checked="" type="checkbox"/>	<input checked="" type="checkbox"/>		<input checked="" type="checkbox"/>	<input checked="" type="checkbox"/>	
B4	motor mounting kit (90 / M6 / 70 / 3 / 16 / 40)							<input checked="" type="checkbox"/>	<input checked="" type="checkbox"/>				

\* Mounting kit: contains gear housing, motor coupling and flange

### Mounting position limit sensor

0	Without sensor
1	10 mm
2	20 mm
3	30 mm
4	40 mm
5	50 mm
6	60 mm
7	70 mm
8	80 mm
9	90 mm
A	100 mm
B	110 mm
C	120 mm
D	130 mm
E	140 mm
F	150 mm
G	160 mm
H	170 mm
J	180 mm
K	190 mm
L	200 mm

### Guide mounting\*\*

Product size HMRS		08	11	15	18	24
00	Without	<input checked="" type="checkbox"/>	<input checked="" type="checkbox"/>	<input checked="" type="checkbox"/>	<input checked="" type="checkbox"/>	<input checked="" type="checkbox"/>
A2	LP050 i = 5	<input checked="" type="checkbox"/>	<input checked="" type="checkbox"/>			
A3	LP050 i = 10	<input checked="" type="checkbox"/>	<input checked="" type="checkbox"/>			
B1	LP070 i = 3		<input checked="" type="checkbox"/>	<input checked="" type="checkbox"/>		
B2	LP070 i = 5		<input checked="" type="checkbox"/>	<input checked="" type="checkbox"/>		
B3	LP070 i = 10		<input checked="" type="checkbox"/>	<input checked="" type="checkbox"/>		
C1	LP090 i = 3					<input checked="" type="checkbox"/>
C2	LP090 i = 5					<input checked="" type="checkbox"/>
C3	LP090 i = 10					<input checked="" type="checkbox"/>
D1	LP120 i = 3					<input checked="" type="checkbox"/>
D2	LP120 i = 5					<input checked="" type="checkbox"/>
D3	LP120 i = 10					<input checked="" type="checkbox"/>

\*\* Mounting kit: contains gear housing, motor coupling, flange and gear



# HMRB Belt



## ORIGA Linear Drives

Series HMRB Belt / Drive Data / Sizes 85, 110, 150, 180, 240 mm

### Description Motor mounting position

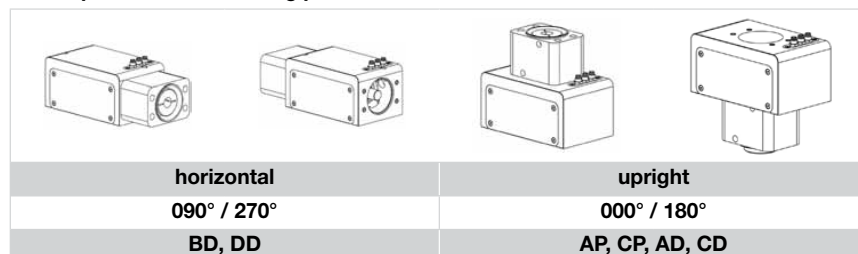

Type and orientation of the belt is given by the motor mounting position.

### Technical data HMRB

Production size		HMRB08		HMRB11		HMRB15	
Motor mounting position		090° / 270°	000° / 180°	090° / 270°	000° / 180°	090° / 270°	000° / 180°
Lead constant	$s_{lin.}$ [mm]	66	66	90	90	100	125
Max. speed	$v_{max.}$ [m/s]	2		2		5	
Max. acceleration	$a_{max.}$ [m/s <sup>2</sup> ]	30		30		50	
Repeatability	[ $\mu$ m]			± 50			
Max. order stroke	[mm]	3,000		4,000		6,000	
Thrust force and torque							
Max. thrust force	$F_{A,max.}$ [N]	295	295	630	630	1,050	630
Max. torque on drive shaft	$M_{A,max.}$ [Nm]	3.1	3.1	9.0	9.0	17.0	13.0
No load torque	$M_0$ [Nm]	1.0	1.0	1.2	1.2	1.2	1.2

### Technical data HMRB

Production size		HMRB18		HMRB24	
Motor mounting position		090° / 270°	000° / 180°	090° / 270°	000° / 180°
Lead constant	$s_{lin.}$ [mm]	130	150	160	224
Max. speed	$v_{max.}$ [m/s]	5		5	
Max. acceleration	$a_{max.}$ [m/s <sup>2</sup> ]	50		50	
Repeatability	[ $\mu$ m]	± 50		± 50	
Max. order stroke	[mm]	6,000		6,000	
Thrust force and torque					
Max. thrust force	$F_{A,max.}$ N	1,300	1,000	4,000	3,750
Max. torque on drive shaft	$M_{A,max.}$ Nm	27	24	101	134
No load torque	$M_0$ Nm	2.0	2.0	4.0	4.0



## ORIGA Linear Drives

Series HMRB / Belt / Thrust Force / Sizes 85, 110, 150, 180, 240 mm

The permissible thrust force from the table is depending on speed level and order stroke length. The minimum thrust force value must not be exceeded in the application.

Information: Limiting the torque from the motor may avoid exceeding permitted thrust force.

### HMRB thrust force

Product size			HMRB08		HMRB11		HMRB15		HMRB18		HMRB24	
Motor mounting position			090° / 270°	000° / 180°	090° / 270°	000° / 180°	090° / 270°	000° / 180°	090° / 270°	000° / 180°	090° / 270°	000° / 180°
Thrust force $F_A$ corresponding to speed $v$	$F_{A(v<1 \text{ m/s})}$	[N]	295	295	630	630	1,050	630	1,300	1,000	4,000	3,750
	$F_{A(v<2 \text{ m/s})}$	[N]	295	295	550	550	990	630	1,300	1,000	4,000	3,380
	$F_{A(v<3 \text{ m/s})}$	[N]	-	-	-	-	930	630	1,300	1,000	3,650	3,140
	$F_{A(v<4 \text{ m/s})}$	[N]	-	-	-	-	890	630	1,300	1,000	3,370	2,950
	$F_{A(v<5 \text{ m/s})}$	[N]	-	-	-	-	840	630	1,300	1,000	3,200	2,800
Thrust force $F_A$ corresponding to order stroke length OS	$F_{A(OS<1000 \text{ mm})}$	[N]	250	250	630	630	1,050	630	1,300	1,000	4,000	3,750
	$F_{A(OS<2000 \text{ mm})}$	[N]	140	140	550	550	820	490	1,000	775	4,000	3,360
	$F_{A(OS<3000 \text{ mm})}$	[N]	100	100	385	385	570	340	710	550	3,370	2,440
	$F_{A(OS<4000 \text{ mm})}$	[N]	-	-	295	295	445	265	550	430	2,860	1,880
	$F_{A(OS<5000 \text{ mm})}$	[N]	-	-	-	-	365	215	450	350	2,350	1,540
	$F_{A(OS<6000 \text{ mm})}$	[N]	-	-	-	-	305	185	380	295	2,000	1,300

#### Example:

HMRB18 with motor mounting position 1 (090° front), speed  $v = 2 \text{ m/s}$  ( $F_A = 1,300 \text{ N}$ ) and order stroke length OS = 2,500 mm ( $F_A = 710 \text{ N}$ ),  
The maximum permissible thrust force  $F_A = 710 \text{ N}$  must not be exceeded.



# ORIGA Linear Drives

Series HMRB / Belt / Dimensions / Sizes 85, 110, 150, 180, 240 mm

## Dimensions

### "Basic" profile

View A

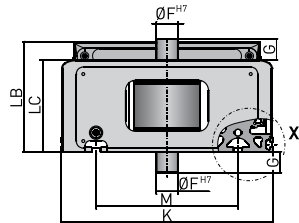

View B

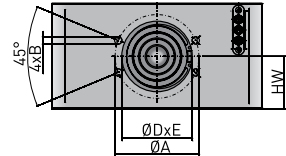

### "Reinforced" profile

View A

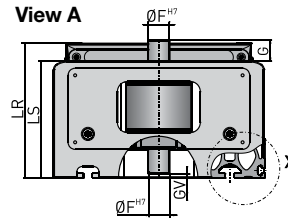

View X

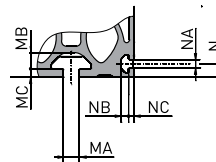

## Dimensions carrier

**B** 3-PIN M8 connections

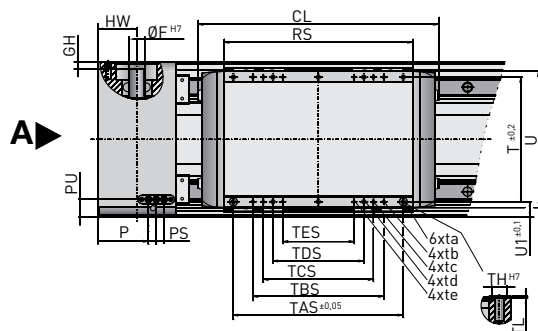
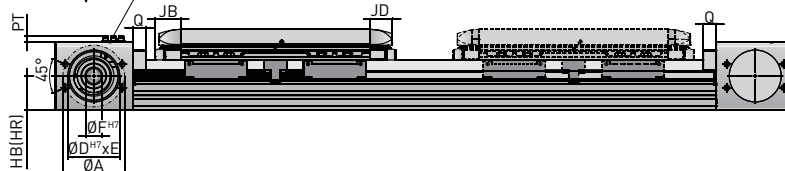

**Dimension table - HMRB**

Size		Ø A	B	Ø D <sup>H7</sup>	E	Ø F <sup>H7</sup>	G	GV	GH	HB	HR	HW	K	LB	LC
HMRB08	[mm]	42.0	M4	34.0	2.5	10.0	13.5	2.5	3.0	26.5	37.5	25.0	85.0	60.0	52.5
HMRB11	[mm]	51.0	M6	39.0	1.2	12.0	20.0	0.0	5.0	30.0	50.0	31.0	110.0	69.5	60.5
HMRB15	[mm]	72.0	M8	54.0	2.1	15.0	19.3	7.0	5.5	36.5	60.5	45.0	150.0	90.0	74.0
HMRB18	[mm]	80.0	M8	64.0	4.0	18.0	21.8	1.5	8.0	45.0	68.0	50.0	180.0	111.5	93.5
HMRB24	[mm]	95.0	M10	80.0	2.5	24.0	24.0	4.0	11.0	52.5	80.5	60.0	240.0	125.0	104.5

**Dimension table - HMRB**

Product size	LR	LS	M	MA	MB	MC	N	NA	NB	NC	P	PS	PT	PU	Q
HMRB08 [mm]	71.0	63.5	50.0	5.2	4.5	1.5	4.5	3.4	3.0	2.5	23.8	12.0	9.0	12.0	16.0
HMRB11 [mm]	89.5	80.5	70.0	5.2	4.5	1.8	4.5	3.4	3.0	2.5	30.8	12.0	9.0	17.0	20.0
HMRB15 [mm]	114.0	98.0	96.0	6.2	6.8	3.0	6.5	5.2	4.6	3.5	48.0	12.0	9.0	21.0	20.0
HMRB18 [mm]	134.5	116.5	116.0	8.0	7.8	4.5	8.5	5.2	4.5	3.5	58.0	12.0	9.0	28.0	20.0
HMRB24 [mm]	153.0	132.5	161.0	10.0	10.2	5.3	8.5	5.2	4.5	3.5	78.0	12.0	9.0	28.6	20.0

**Dimension table - carrier standard HMRB**

Product size	JB	JD	CL	RS	T	TAS	ta	TBS	tb	TCS	tc	TDS
HMRB08 [mm]	33.5	30.0	195.0	128.0	74.0	97.0	M4x12	70.0	M4x12	40.0	M4x12	-
HMRB11 [mm]	37.5	34.0	225.0	150.0	96.0	122.0	M5x12	97.0	M5x12	65.0	M5x12	25.0
HMRB15 [mm]	37.5	34.0	266.0	191.0	120.0	170.0	M5x12	122.0	M5x12	-	-	70.0
HMRB18 [mm]	40.0	34.0	311.0	231.0	150.0	202.0	M6x12	170.0	M5x10	122.0	M5x10	90.0
HMRB24 [mm]	40.0	34.0	371.0	291.0	192.0	262.0	M8x16	202.0	M6x12	170.0	M5x10	140.0

**Dimension table - carrier standard HMRB**

Product size	td	TES	te	ØTK <sup>H7</sup>	TL	U	U1
HMRB08 [mm]	-	-	-	7.0	1.5	83.0	5.5
HMRB11 [mm]	M5x12	-	-	7.0	1.5	105.0	7.0
HMRB15 [mm]	M5x12	-	-	7.0	1.5	135.0	15.0
HMRB18 [mm]	M6x12	-	-	9.0	1.5	165.0	15.0
HMRB24 [mm]	M8x16	122.0	M5x10	12.0	1.5	210.0	24.0

## ORIGA Linear Drives

Series HMRB / Weight, Mass and Inertia

### Weight and mass HMRB

Product size		HMRB08				HMRB11				HMRB15			
		Weight of actuator											
Version actuator (see order code)		B	C	R	S	B	C	R	S	B	C	R	S
Weight. 0 - order stroke	$m_0$ [kg]	2.4	2.7	3.1	3.4	4.4	4.8	6.1	6.5	6.7	7.5	9.4	10.3
Weight per 1 m order stroke	$m_{mt}$ [kg/m]	3.0	4.0	4.0	5.0	5.4	6.4	7.6	8.6	8.2	9.9	11.5	13.3
		Moving mass carrier											
Version of carrier (see order code)		0	1	0	1	0	1	0	1	0	1	0	1
Weight carrier	$m_c$ [kg]	0.9	0.7	1.7	1.3	2.7	1.9						

### Weight and mass HMRB

Product size		HMRB18				HMRB24			
		Weight of actuator							
Version actuator (see order code)		B	C	R	S	B	C	R	S
Weight. 0 - order stroke	$m_0$ [kg]	11.6	12.8	15.6	16.7	21.5	23.1	28.0	29.6
Weight per 1 m order stroke	$m_{mt}$ [kg/m]	12.8	15.1	16.5	18.7	21.6	24.4	26.7	29.5
		Moving mass carrier							
Version of carrier (see order code)		0	1	0	1	0	1	0	1
Weight carrier	$m_c$ [kg]	4.6	3.7	9.0	7.2				

Total mass HMRB:  $m_{tot} = m_0 + m_c + \text{order stroke} * m_{mt}$

### Inertia HMRB

Product size		HMRB08		HMRB11		HMRB15	
Motor mounting position (see order code)		090°/270°	000°/180°	090°/270°	000°/180°	090°/270°	000°/180°
Inertia							
Inertia 0 - order stroke	$J_0$ [kgmm <sup>2</sup> ]	14	14	52	52	102	145
Inertia per 1 m order stroke	$J_{mt}$ [kgmm <sup>2</sup> /m]	10	10	41	41	79	79
Inertia per 1 kg moving mass	$J_{kg}$ [kgmm <sup>2</sup> /kg]	110	110	205	205	253	396

### Inertia HMRB

Product size		HMRB18		HMRB24	
Motor mounting position (see order code)		090°/270°	000°/180°	090°/270°	000°/180°
Inertia					
Inertia 0 - order stroke	$J_0$ [kgmm <sup>2</sup> ]	297	394	1,178	2,758
Inertia per 1 m order stroke	$J_{mt}$ [kgmm <sup>2</sup> /m]	134	222	689	900
Inertia per 1 kg moving mass	$J_{kg}$ [kgmm <sup>2</sup> /kg]	428	570	649	1,271

Inertia total HMRB:  $J_{tot} = J_0 + \text{order stroke} * J_{mt} + m_c * J_{kg} + m * J_{kg}$



## ORIGA Linear Drives

Series HMRB Belt / Order stroke / Sizes 85, 110, 150, 180, 240 mm

### Stroke depending dimensions

- ES = Effective Stroke
- SS = Safety Stroke
- CD = Carriage distance
- CL = Carriage length Standard
- S = Stroke
- OS = Order Stroke
- OAL = Over All Length

### Option Carrier Standard

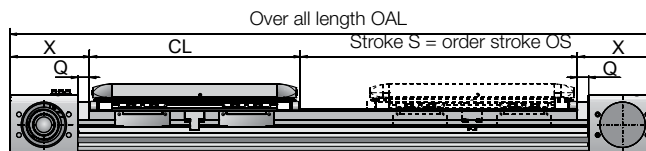

Order stroke OS = Effective stroke ES + 2 x Safety stroke SS  
 Over all length OAL = Order stroke OS + Carrier length CL + 2 x End cap length X

### Option Carrier Tandem

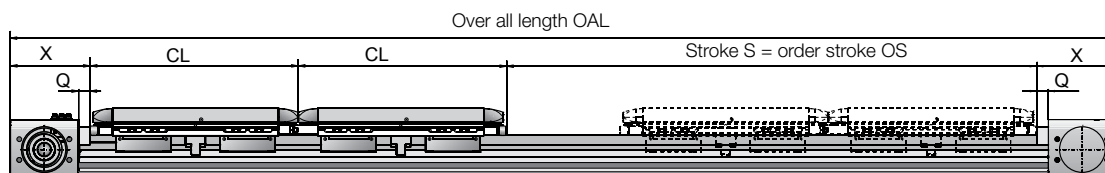

Order stroke OS = Effective stroke ES + 2 x Safety stroke SS + Carrier distance CD (not shown)  
 Over all length OAL = Order stroke OS + 2 x Carrier length CL + 2 x End cap length X

### Option Carrier Bi-part for opposite movements

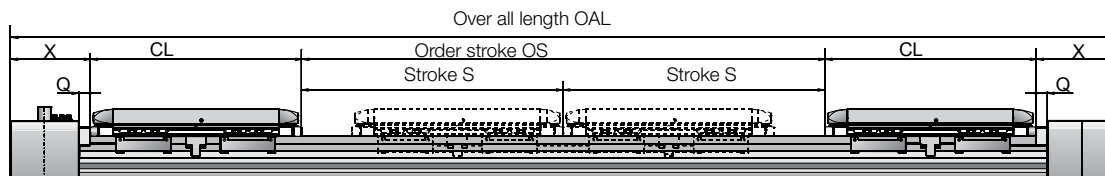

Order stroke OS = 2 x Stroke S = 2 x Effective stroke ES + 4 x Safety stroke SS + Carrier distance CD (not shown)  
 Over all length OAL = Order stroke OS + 2 x Carrier length CL + 2 x End cap length X

### Dimensions - Carriage and end cap HMRB

Product size	CL	Q	X
HMRB08 [mm]	195.0	16.0	74.0
HMRB11 [mm]	225.0	20.0	85.0
HMRB15 [mm]	266.0	20.0	110.0
HMRB18 [mm]	311.0	20.0	120.0
HMRB24 [mm]	371.0	20.0	140.0



# ORIGA Linear Drives

Product series HMRB

<b>Order code</b>	HMR	B	15	B	BD	0	-	0000	-	0	0	0	0	0	00	00
-------------------	-----	---	----	---	----	---	---	------	---	---	---	---	---	---	----	----

<b>Type of actuator</b>	B Belt
-------------------------	--------

<b>Product size</b>	08 Product width 085 mm
	11 Product width 110 mm
	15 Product width 150 mm
	18 Product width 180 mm
	24 Product width 240 mm

<b>Actuator design</b>	B Basic Profile with ball bearing guide Standard
	C Basic Profile with ball bearing guide and IP54 with outer cover
	R Reinforced Profile with ball bearing guide Standard
	S Reinforced Profile with ball bearing guide and IP54 with outer cover

<b>Motor mounting position and drive shaft design</b>	BD 090° front with double plain shaft
	DD 270° back with double plain shaft
	AP 000° up with single plain shaft
	CP 180° down with single plain shaft
	AD 000° up with double plain shaft
	CD 180° down with double plain shaft

<b>Carriage design</b>	0 Standard
	1 Tandem
	2 Bi-part

<b>Order stroke</b>	0000 4 digits input in mm
---------------------	---------------------------

<b>Home Sensor (one sensor)</b>	0 No home sensor
	1 R2NO-I: Reed, 2 wire, NO, internal
	A P3NO-I: PNP, 3 wire, NO, internal
	K N3NO-I: NPN, 3 wire, NO, internal
	3 R2NO-P: Reed, 2 wire, NO, M8 plug, 0.3 m cable, external
	C P3NO-P: PNP, 3 wire, NO, M8 plug, 0.3 m cable, external
	M N3NO-P: NPN, 3 wire, NO, M8 plug, 0.3 m cable, external
	5 R2NO-FL3: Reed, 2 wire, NO, Flying leads, 3 m cable, external
	E P3NO-FL3: PNP, 3 wire, NO, Flying leads, 3 m cable, external
	P N3NO-FL3: NPN, 3 wire, NO, flying leads, 3 m cable, external
	7 R2NO-FL10: Reed, 2 wire, NO, flying leads, 10 m cable, external
	G P3NO-FL10: PNP, 3 wire, NO, flying leads, 10 m cable, external
	R N3NO-FL10: NPN, 3 wire, NO, flying leads, 10 m cable, external

<b>Limit Sensor (one sensor each end)</b>	0 No limit sensor
	2 R2NC-I: Reed, 2 wire, normally close, internal
	B P3NC-I: PNP, 3 wire, normally close, internal
	L N3NC-I: NPN, 3 wire, normally close, internal
	4 R2NC-P: Reed, 2 wire, normally close, M8 plug, 0.3 m cable, external
	D P3NC-P: PNP, 3 wire, normally close, M8 plug, 0.3 m cable, external
	N N3NC-P: NPN, 3 wire, normally close, M8 plug, 0.3 m cable, external
	6 R2NC-FL3: Reed, 2 wire, normally close, flying leads, 3 m cable, external
	F P3NC-FL3: PNP, 3 wire, normally close, flying leads, 3 m cable, external
	Q N3NC-FL3: NPN, 3 wire, normally close, flying leads, 3 m cable, external
	8 R2NC-FL10: Reed, 2 wire, normally close, flying leads, 10 m cable, external
	H P3NC-FL10: PNP, 3 wire, normally close, flying leads, 10 m cable, external
	S N3NC-FL10: NPN, 3 wire, normally close, flying leads, 10m cable, external

**Mounting kits\***

<b>Product size HMRB</b>		<b>08</b>	<b>11</b>	<b>15</b>	<b>18</b>	<b>24</b>									
00	No mounting kit or motor mounting	<input checked="" type="checkbox"/>	<input checked="" type="checkbox"/>	<input checked="" type="checkbox"/>	<input checked="" type="checkbox"/>	<input checked="" type="checkbox"/>									
<b>Mounting kit Gear</b>				<b>15</b>	<b>18</b>	<b>24</b>									
A7	PS60			<input checked="" type="checkbox"/>	<input checked="" type="checkbox"/>										
A8	PS90				<input checked="" type="checkbox"/>										
A9	PS115					<input checked="" type="checkbox"/>									
C0	LP050	<input checked="" type="checkbox"/>	<input checked="" type="checkbox"/>												
C1	PV60-TA / LP070		<input checked="" type="checkbox"/>	<input checked="" type="checkbox"/>	<input checked="" type="checkbox"/>										
C2	PV90-TA / LP090				<input checked="" type="checkbox"/>										
C3	PV115-TA / LP120					<input checked="" type="checkbox"/>									
<b>Mounting kit Motor</b>															
<b>Size Gear mounting</b>		<b>08</b>	<b>11</b>	<b>15</b>	<b>18</b>	<b>24</b>	<b>Ax</b>	<b>Bx</b>	<b>Cx</b>	<b>Dx</b>	<b>Fx</b>	<b>Gx</b>	<b>Hx</b>		
A2	SMx60 8/11, MH56 5/11, NX2	<input checked="" type="checkbox"/>	<input checked="" type="checkbox"/>	<input checked="" type="checkbox"/>			<input checked="" type="checkbox"/>	<input checked="" type="checkbox"/>			<input checked="" type="checkbox"/>				
A3	SMx82 8/14		<input checked="" type="checkbox"/>	<input checked="" type="checkbox"/>	<input checked="" type="checkbox"/>			<input checked="" type="checkbox"/>	<input checked="" type="checkbox"/>		<input checked="" type="checkbox"/>	<input checked="" type="checkbox"/>	<input checked="" type="checkbox"/>	<input checked="" type="checkbox"/>	<input checked="" type="checkbox"/>
A4	SMx100 5/19, MH105 5/19			<input checked="" type="checkbox"/>	<input checked="" type="checkbox"/>	<input checked="" type="checkbox"/>			<input checked="" type="checkbox"/>	<input checked="" type="checkbox"/>		<input checked="" type="checkbox"/>	<input checked="" type="checkbox"/>	<input checked="" type="checkbox"/>	<input checked="" type="checkbox"/>
A5	SMx115 5/24, SMx142 5/24, MH145 5/24				<input checked="" type="checkbox"/>	<input checked="" type="checkbox"/>			<input checked="" type="checkbox"/>	<input checked="" type="checkbox"/>				<input checked="" type="checkbox"/>	<input checked="" type="checkbox"/>
AG	SMx60 5/11, MH70 5/11, NX3	<input checked="" type="checkbox"/>	<input checked="" type="checkbox"/>				<input checked="" type="checkbox"/>	<input checked="" type="checkbox"/>			<input checked="" type="checkbox"/>				
AL	MPP092							<input checked="" type="checkbox"/>	<input checked="" type="checkbox"/>						
AK	AK - SMx115 7/24, MH105 9/24, NX6								<input checked="" type="checkbox"/>	<input checked="" type="checkbox"/>				<input checked="" type="checkbox"/>	
AJ	SMx82 8/19, MH105 7/19, NX4								<input checked="" type="checkbox"/>	<input checked="" type="checkbox"/>		<input checked="" type="checkbox"/>			
AH	SMx60 8/9, MH56 5/9	<input checked="" type="checkbox"/>	<input checked="" type="checkbox"/>				<input checked="" type="checkbox"/>	<input checked="" type="checkbox"/>			<input checked="" type="checkbox"/>				
B0	motor mounting kit (75 / M6 / 60 / 3 / 14 / 30)	<input checked="" type="checkbox"/>						<input checked="" type="checkbox"/>	<input checked="" type="checkbox"/>		<input checked="" type="checkbox"/>				
B1	motor mounting kit (90 / M5 / 60 / 3 / 11 / 23)	<input checked="" type="checkbox"/>	<input checked="" type="checkbox"/>				<input checked="" type="checkbox"/>	<input checked="" type="checkbox"/>							
B2	motor mounting kit (90 / M5 / 60 / 3 / 14 / 30)	<input checked="" type="checkbox"/>	<input checked="" type="checkbox"/>					<input checked="" type="checkbox"/>	<input checked="" type="checkbox"/>						
B3	motor mounting kit (95 / M6 / 50 / 3 / 14 / 30)	<input checked="" type="checkbox"/>	<input checked="" type="checkbox"/>					<input checked="" type="checkbox"/>	<input checked="" type="checkbox"/>		<input checked="" type="checkbox"/>	<input checked="" type="checkbox"/>			
B4	motor mounting kit (90 / M6 / 70 / 3 / 16 / 40)							<input checked="" type="checkbox"/>	<input checked="" type="checkbox"/>						
B8	motor mounting kit (63 / M4 / 40 / 3 / 9 / 20)						<input checked="" type="checkbox"/>								

\* Mounting kit consisting coupling housing, motor coupling and flange

**Mounting position limit sensor**

0	No limit sensor
1	10 mm
2	20 mm
3	30 mm
4	40 mm
5	50 mm
6	60 mm
7	70 mm
8	80 mm
9	90 mm
A	100 mm
B	110 mm
C	120 mm
D	130 mm
E	140 mm
F	150 mm
G	160 mm
H	170 mm
J	180 mm
K	190 mm
L	200 mm

**Gear mounting\*\***

<b>Product size HMRB</b>		<b>08</b>	<b>11</b>	<b>15</b>	<b>18</b>	<b>24</b>
00	No Gear mounting	<input checked="" type="checkbox"/>	<input checked="" type="checkbox"/>	<input checked="" type="checkbox"/>	<input checked="" type="checkbox"/>	<input checked="" type="checkbox"/>
A2	LP050 i = 5	<input checked="" type="checkbox"/>	<input checked="" type="checkbox"/>			
A3	LP050 i = 10	<input checked="" type="checkbox"/>	<input checked="" type="checkbox"/>			
B1	LP070 i = 3		<input checked="" type="checkbox"/>	<input checked="" type="checkbox"/>	<input checked="" type="checkbox"/>	
B2	LP070 i = 5		<input checked="" type="checkbox"/>	<input checked="" type="checkbox"/>	<input checked="" type="checkbox"/>	
B3	LP070 i = 10		<input checked="" type="checkbox"/>	<input checked="" type="checkbox"/>	<input checked="" type="checkbox"/>	
C1	LP090 i = 3					<input checked="" type="checkbox"/>
C2	LP090 i = 5					<input checked="" type="checkbox"/>
C3	LP090 i = 10					<input checked="" type="checkbox"/>
D1	LP120 i = 3					<input checked="" type="checkbox"/>
D2	LP120 i = 5					<input checked="" type="checkbox"/>
D3	LP120 i = 10					<input checked="" type="checkbox"/>
F1	PS60-003-S2 i=3			<input checked="" type="checkbox"/>		
F2	PS60-005-S2 i=3			<input checked="" type="checkbox"/>		
F3	PS60-010-S2 i=3			<input checked="" type="checkbox"/>		
G1	PS90-003-S2 i=3				<input checked="" type="checkbox"/>	
G2	PS90-005-S2 i=3				<input checked="" type="checkbox"/>	
G3	PS90-010-S2 i=3				<input checked="" type="checkbox"/>	
H1	PS115-003-S2 i=3					<input checked="" type="checkbox"/>
H2	PS115-005-S2 i=3					<input checked="" type="checkbox"/>
H3	PS115-010-S2 i=3					<input checked="" type="checkbox"/>

\*\* Mounting kit consisting coupling housing, motor coupling, flange and gear



# HMR Options



## ORIGA Linear Drives

*HMR Series / Option / Protection Class*

**Versions:**

**standard:** without cover

**IP54:** with cover

HMR was developed for various environment conditions.  
HMR can be equipped with a cover to comply with IP54 protection class if a higher rating is required.

**Version – standard**

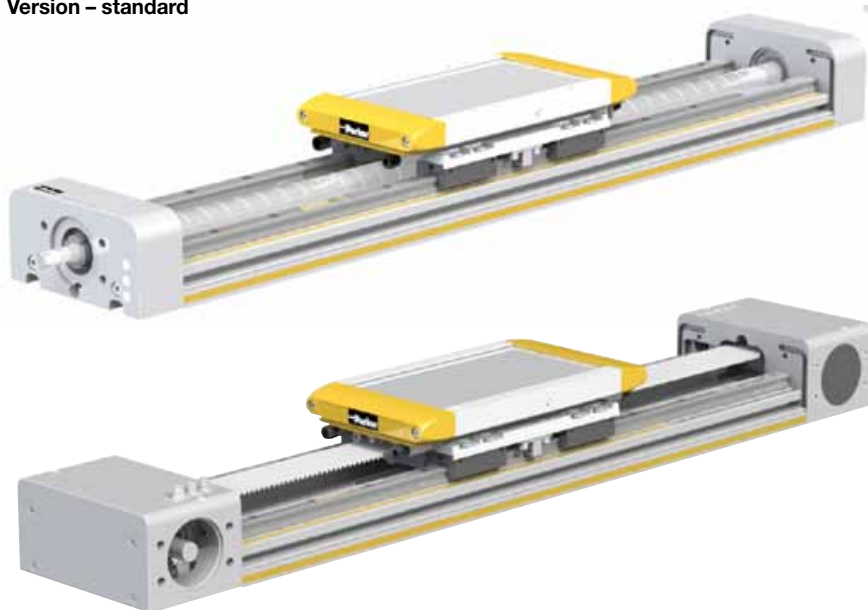

**Version – protection class IP54**



## ORIGA Linear Drives

### HMR series / Option / Impact protection

HMR can be equipped with impact protection. The mounted structure shock absorbers can compensate the energy released by unintentional impact and afford protection against mechanical damage.

Two structure shock absorbers are fitted to each side of the carriage prior to delivery.

#### Shock absorbers for impact protection

Product size		HMRx08	HMRx11	HMRx15	HMRx18	HMRx24
Shock absorber		TA12-5	TA12-5	TA12-5	TA17-7	TA17-7
Energy absorption	[Nm/stroke]	3.0	3.0	3.0	8.5	8.5
Maximum stroke	[mm]	5.0	5.0	5.0	7.0	7.0

#### Distance-force and energy-distance characteristic curve (dynamic) – production sizes HMRx08, HMRx11, HMRx15

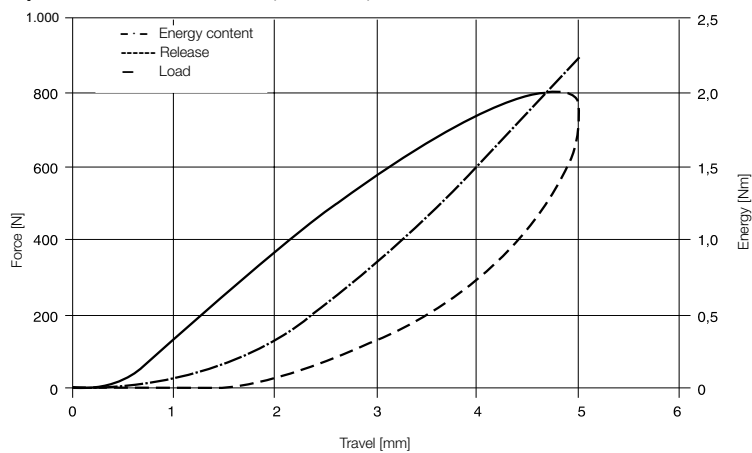

#### Distance-force and energy-distance characteristic curve (dynamic) – production sizes HMRx18, HMRx24

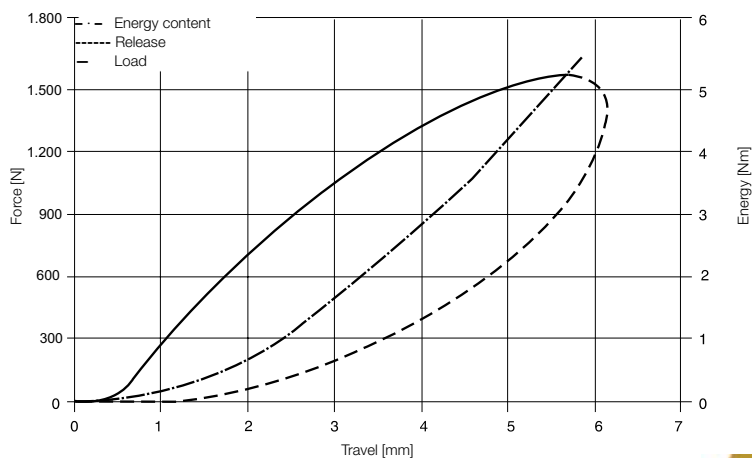



# Magnetic Field Sensors



## Type P8S

The new generation of t-slot sensors convince with easy mounting avoiding special tools and with a drop in mountage. Due to new electronic the hysteresis is very small and allows a very accurate switching point.

Magnetic sensors are used for contactless electric sensing of the carrier position, e.g. for end or homing positions of a linear acuator. The field of magnets mounted as standard into the carriage activate the sensor.

## Electric Service Life

### Protective Measures

Type RS magnetic sensors are sensitive to excessive currents and inductions. With high switching frequencies and inductive loads such as relays, solenoid valves or lifting magnets, service life will be greatly reduced.

With resistive and capacitative loads with high switch-on current, such as light bulbs, a protective resistor should be fitted. This also applies to long cable lengths and voltages over 100 V.

In the switching of inductive loads such as relays, solenoid valves and lifting magnets, voltage peaks (transients) are generated which must be suppressed by protective diodes, RC loops or varistors.

## Connection Examples

Load with protective circuits

- (a) Protective resistor for light bulb
- (b) Freewheel diode on inductivity
- (c) Varistor on inductivity
- (d) RC element on inductivity

For the type EST, external protective circuits are not normally needed.

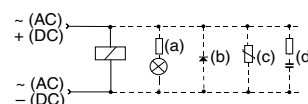

**The possible speed of the load-bearing element or carriage must take the minimum response time of downstream devices into account.**

**Contact travel is considered accordingly in the calculations.**

$\text{Minimum response time} = \frac{\text{Contact travel}}{\text{Overrun speed}}$
---

Series		P8S-G <sup>1)</sup> - insertable into T-Slot from top					
Type		M8R <sup>2)</sup>			FL <sup>3)</sup>		
							
<b>CE. cULus. RoHs</b>							
<b>Output Function</b>		0.3 m Cable	3 m Cable	10 m Cable	0.3 m Cable	3 m Cable	10 m Cable
PNP	NO	P8S-GPCHX	P8S-GPFAX	P8S-GPFDX			
	NC	P8S-GQCHX	P8S-GQFAX	P8S-GQFDX			
NPN	NO	P8S-GNCHX	P8S-GNFAX	P8S-GNFDX			
	NC	P8S-GMCHX	P8S-GMFAX	P8S-GMFDX			
REED	NO				P8S-GRCHX	P8S-GRFAX	P8S-GRFDX
	NC				P8S-GECNX	P8S-GEFFX	P8S-GEFRX
<b>Technical Data</b>		<b>Electrical</b>			<b>Reed</b>		
<b>Electrical Characteristics</b>							
Electric Configuration		3-pole			2-pole		
Indicator LED yellow		yes			yes (not NC)		
Operating Voltage U <sub>b</sub> [V]		10 - 30 DC			10 - 30 AC/DC		
Ripple of U <sub>b</sub> [%]		≤ 10			≤ 10		
Voltage Drop U <sub>d</sub> [V]		≤ 2			≤ 3		
Power Consumption <sup>4)</sup> [mA]		≤ 10					
Continuous Current I <sub>a</sub> [mA]		≤ 100			≤ 500 (NO ≤ 100)		
Max. Switching Capacity [W]		≤ 6			≤ 10		
Switchable Capacity Load @ 100W @ 24VDC [nF]					100		
Switching Frequency [Hz]		≤ 1,000			≤ 400		
Time delay before availability [ms]		0.5 / 0.5			1.5 / 0.5		
Sensitivity [mT]		2.8			3		
Hysteresis [mT]		0.7			≥ 0.2		
EMC <sup>6)</sup>		yes			yes		
Lifetime		unlimited			≥ 20*10 <sup>6</sup> Cycles		
Short Circuit Protection <sup>5)</sup>		yes					
Reverse Polarity Protection		yes					
Power-Up Pulse Suppression		yes					
Protection for Inductive Load		yes					
ATEX Version		on request					
<b>Mechanical Characteristics</b>							
Housing		PA12					
Cable Type		PUR / black					
Cable Cross Section [mm <sup>2</sup> ]		Connector 3-pole	3 x 0.14	3 x 0.14	Connector 3-pole	2 x 0.14	2 x 0.14
Bending Radius Fixed Installation [mm]		≥ 30					
Bending Radius Moving [mm]		≥ 45					
<b>Shock Resistance</b>							
Protection <sup>7)</sup> [IP]		67					
Ambient Temperature Range T <sub>a</sub> [°C]		-25 ... +75					
Shock <sup>8)</sup> / Vibration <sup>9)</sup>		30 g, 11 ms / 10 to 55 Hz, 1 mm					

<sup>1)</sup> without OSP-E...STR

<sup>2)</sup> plug M8 with rotatable nut

<sup>3)</sup> Cable with Flying Leads

<sup>4)</sup> unloaded U<sub>b</sub> = 24V

<sup>5)</sup> clocked

<sup>6)</sup> to EN 60529

<sup>7)</sup> to EN 60529

<sup>8)</sup> to EN 60068-2-27

<sup>9)</sup> to EN 60068-2-6

### Switching function and electrical connection

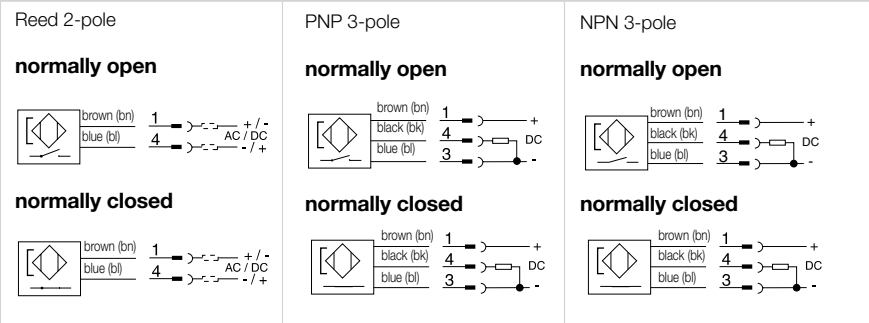

### Dimensions (mm) - Type P8S

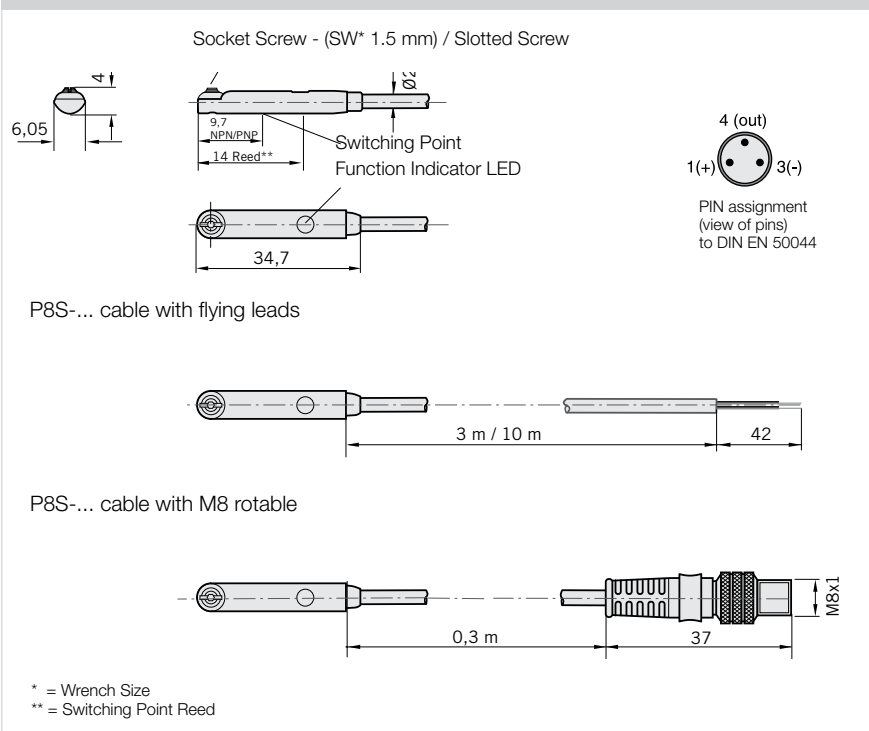

### Installation for Magnetic T-Slot Sensors

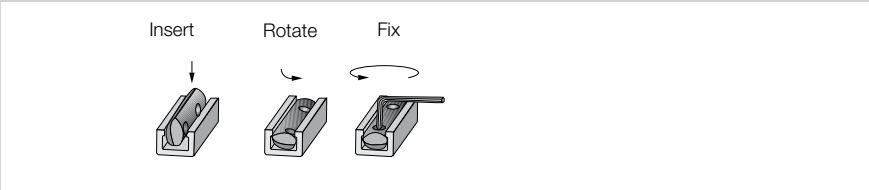

### Connection Cables suitable for cable chain

M8 Plug with 5 m cable	KL3186*
M8 Plug with 10 m cable	KL3217*
M8 Plug with 15 m cable	KL3216*

\* Detailed specifications for KL-Series on request.





# HMR Accessories



## ORIGA Linear Drives

HMR Series / Accessories / Coupling housing

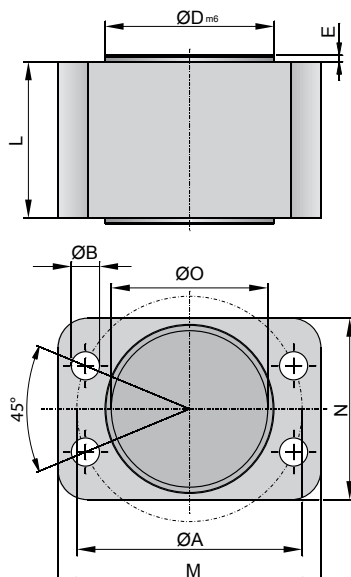

**Dimension table - Coupling housing long HMRS / HMRB [mm]**

Product size	Ø A	Ø B	Ø D <sub>m6</sub>	E	Ø O	L	M	N	Order no.
HMRx08	42	4.5	34	2	30	28	49	37	56568FIL
HMRx11	51	6.6	39	1	35	37	60	42	56566FIL
HMRx15	72	9.0	54	2	50	54	84	58	50353FIL
HMRx18	80	9.0	64	2	60	70	90	68	50655FIL
HMRx24	95	11.0	80	2	77	85	107	85	56415FIL

- suitable for all types of HMRS
- suitable for HMR with motor orientation 000° top  
(HMRBxxxAP; HMRBxxxAD)
- suitable for HMR with motor orientation 180° bottom and profile version Basic  
(HMRBxxBCP; HMRBxxBCD; HMRBxxCCP; HMRBxxCCD)

**Dimension table - Coupling housing short HMRB [mm]**

Product size	Ø A	Ø B	Ø D <sub>m6</sub>	E	Ø O	L	M	N	Order no.
HMRB08	42	4.5	34	2	30	13	49	37	56567FIL
HMRB08 *	42	4.5	34	2	30	17	49	37	56569FIL
HMRB11	51	6.6	39	1	35	15	60	42	56565FIL
HMRB15	72	9.0	54	2	50	30	84	58	56412FIL
HMRB18	80	9.0	64	2	60	42	90	68	56413FIL
HMRB24	95	11.0	80	2	77	60	107	85	56414FIL

- suitable for HMR with motor orientation 090° front and 270° rear  
(HMRBxxxBD; HMRBxxxDD)
- suitable for HMR with motor orientation 180° bottom re-inforced profile  
(HMRBxxRCP; HMRBxxRCD; HMRBxxSCP; HMRBxxSCD)



## ORIGA Linear Drives

HMR series / Accessories / Motor coupling

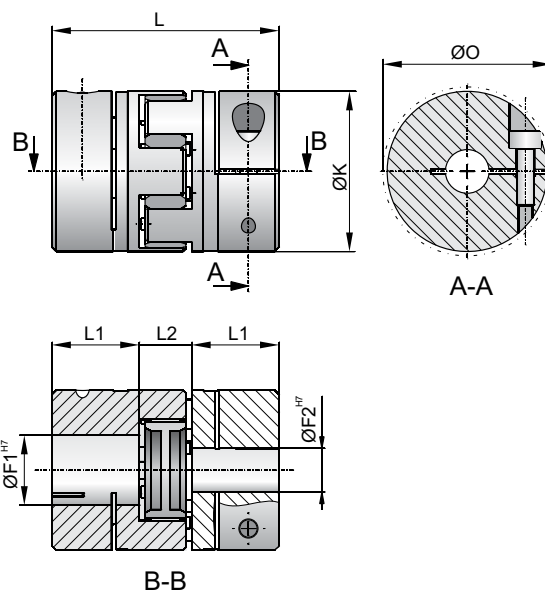

### Ball screw

Dimension table - motor coupling HMRS [mm]

Product size	F <sub>1</sub>	F <sub>2</sub>	F	K	L	L <sub>1</sub>	L <sub>2</sub>	Ø O	Order no.
HMRS08	6	9	5 - 12	25	34	11	12	27.5	56562FIL
HMRS11	10	9	6 - 16	30	35	11	13	32.5	13210FIL
HMRS15	12	9	8 - 24	40	66	25	16	58.0	56400FIL
HMRS18	15	14	10 - 28	55	78	30	18	68.0	56402FIL
HMRS24	20	14	14 - 38	65	90	35	20	73.0	56510FIL

### Belt

Dimension table - motor coupling HMRB [mm]

Product size	F <sub>1</sub>	F <sub>2</sub>	F	K	L	L <sub>1</sub>	L <sub>2</sub>	Ø O	Order no.
HMRB08	10	9	5 - 12	25	34	11	12	27.5	56563FIL
HMRB11	12	9	6 - 16	30	35	11	13	32.5	56560FIL
HMRB15	15	10	8 - 24	40	66	25	16	58.0	16239FIL
HMRB18	18	14	10 - 28	55	78	30	18	68.0	56411FIL
HMRB24	24	15	14 - 38	65	90	35	20	73.0	16260FIL



## ORIGA Linear Drives

HMR series / Accessories / Mountings

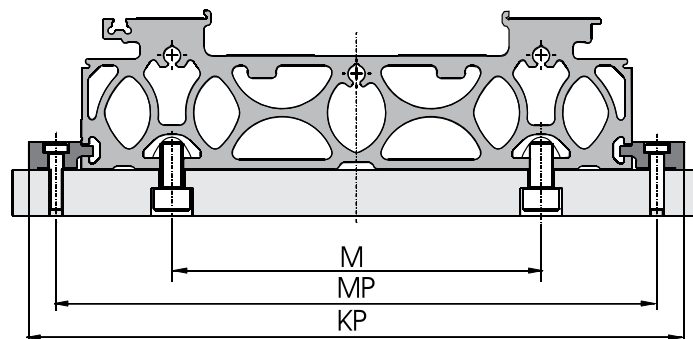

Dimension table - Product width HMR [mm]

Product size	T-slot fixture		T-slot mounting
	MP	KP	M
HMRx08	97	115	50
HMRx11	122	140	70
HMRx15	170	190	96
HMRx18	202	226	116
HMRx24	262	286	161

Holding force per mounting set [N]

Product size	Mounting bracket				T-nut			
	In longitudinal direction of the actuator*	Screw 2x	Tightening torque [Nm]	Max. load per screw	In longitudinal direction of the actuator*	Screw 1x	Tightening torque [Nm]	Max. load per screw
HMRx08	800	M4	3	900	1,000	M5	6	1,200
HMRx11	800	M4	3	900	1,000	M5	6	1,200
HMRx15	1,820	M5	6	1,200	1,600	M6	10	1,700
HMRx18	2,610	M6	10	1,700	2,700	M8	20	3,400
HMRx24	2,610	M6	10	1,700	3,200	M10	40	5,500

\*A friction factor of 0.15 between profile and mounting surface was taken as a basis for the calculation of the forces that can be transmitted in longitudinal direction, Screw property class 8.8.

## ORIGA Linear Drives

HMR series / Accessories / T-slot mounting / T-slot fixture

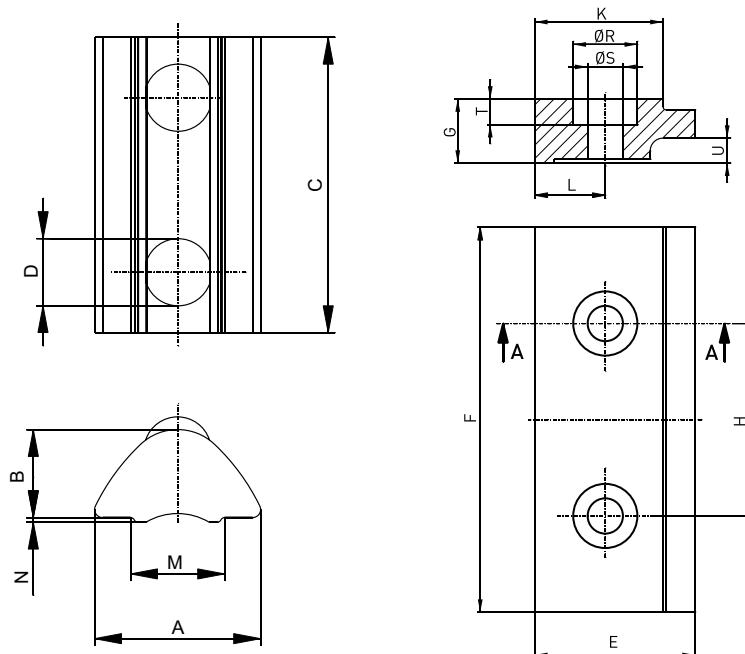

Dimension table - T-slot mounting HMR [mm]

Product size	A	B	C	Ø D	M	N	Order no. *
HMRx08	8.0	4.0	11.5	M5	5.0	0.5	56351FIL
HMRx11	8.0	4.0	11.5	M5	5.0	0.5	56351FIL
HMRx15	10.5	6.4	22.5	M6	6.4	0.6	56352FIL
HMRx18	13.5	6.7	22.5	M8	8.5	1.0	56353FIL
HMRx24	16.5	8.9	28.5	M10	10.5	1.0	56354FIL

\* Packing unit 10 pc

Dimension table - T-slot fixture HMR [mm]

Product size	E	F	G	H	K	L	Ø R	Ø S	T	U	Order no. *
HMRx08	18.0	40.0	7.5	20.0	15.0	9.0	0.0	4.5	0.0	2.8	56363FIL
HMRx11	18.0	40.0	7.5	20.0	15.0	9.0	0.0	4.5	0.0	2.8	56363FIL
HMRx15	25.0	60.0	10.0	30.0	20.0	11.0	10.0	5.5	4.0	3.9	56355FIL
HMRx18	28.0	80.0	12.0	40.0	23.0	12.0	11.0	6.6	4.7	5.9	56356FIL
HMRx24	28.0	80.0	12.0	40.0	23.0	12.0	11.0	6.6	4.7	5.9	56356FIL

\* Packing unit 1 pair incl. screws



## Drive Combinations

<b>Ball Screw Drive</b>				
				
Type of drive		Coupling housing	Motor coupling	Motor flange
HMRS-08		56568FIL	56553FIL	56590FIL
			56555FIL	56594FIL
HMRS-11		56566FIL	12074FIL	56588FIL
			10801FIL	56592FIL
HMRS-15		50353FIL	16498FIL	56528FIL
			16866FIL	50358FIL
HMRS-18		50655FIL	56402FIL	56504FIL
			56403FIL	50660FIL
HMRS-24		56415FIL	56513FIL	56515FIL
			56512FIL	56462FIL
			56512FIL	56462FIL



Servo motor	Motor cable	Resolver cable	Controller	Connector kit
SMH60 60 1,4 8 11 S 2ID 65 4	MOK54/03	REK41/03	C3S 015 V4 F10 I11 T11 M00	ZBH02/02
SMH82 60 03 8 14 S 2ID 65 4	MOK54/03	REK41/03	C3S 038 V4 F10 I11 T11 M00	
SMH60 60 1,4 8 11 S 2ID 65 4	MOK54/03	REK41/03	C3S 015 V4 F10 I11 T11 M00	ZBH02/02
SMH82 60 03 8 14 S 2ID 65 4	MOK54/03	REK41/03	C3S 038 V4 F10 I11 T11 M00	
SMH60 60 1,4 8 11 S 2ID 65 4	MOK54/03	REK41/03	C3S 015 V4 F10 I11 T11 M00	ZBH02/02
SMH82 60 03 8 14 S 2ID 65 4	MOK54/03	REK41/03	C3S 038 V4 F10 I11 T11 M00	
SMH82 60 03 8 14 S 2ID 65 4	MOK54/03	REK41/03	C3S 038 V4 F10 I11 T11 M00	ZBH02/02
SMH100 56 06 5 19 S 2ID 65 4	MOK54/03	REK41/03	C3S 075 V4 F10 I11 T11 M00	
SMH100 56 06 5 19 S 2ID 65 4	MOK54/03	REK41/03	C3S 075 V4 F10 I11 T11 M00	ZBH02/02
SMH115 56 10 5 24 S 2I 65 4	MOK57/03	REK41/03	C3S 150 V4 F10 I11 T11 M00	
SMH142 56 15 5 24 S 2I 65 4	MOK57/03	REK41/03	C3S 150 V4 F10 I11 T11 M00	

## Drive Combinations

<b>Belt Drive</b>						
Type of drive	Profile version	Motor mounting position	Example	Coupling housing	Motor coupling	Motor flange
HMRB-08	B, C, R, S	BD = 090° front	HMRB08BBD...	56567FIL	56557FIL	56585FIL
		DD = 270° back	HMRB08BDD...			
	B, C	AP, AD = 000° up	HMRB08BAP...			
	B, C	CP, CD = 180° down	HMRB08BCP...	56568FIL		
	R, S	AP, AD = 000° up	HMRB08RAP...	56569FIL		
HMRB-11	B, C, R, S	BD = 090° front	HMRB11BBD...	56565FIL	56570FIL	56579FIL
		DD = 270° back	HMRB11BDD...			
	B, C	AP, AD = 000° up	HMRB11BAP...			
	B, C	CP, CD = 180° down	HMRB11BCP...	56566FIL	56559FIL	56582FIL
	R, S	AP, AD = 000° up	HMRB11RAP...	56565FIL		
HMRB-15	B, C, R, S	BD = 090° front	HMRB15BBD...	56412FIL	15227FIL	56423FIL
		DD = 270° back	HMRB15BDD...			
	B, C	AP, AD = 000° up	HMRB15BAP...			
	B, C	CP, CD = 180° down	HMRB15BCP...	50353FIL		
	R, S	AP, AD = 000° up	HMRB15RAP...	56412FIL		
HMRB-18	B, C, R, S	BD = 090° front	HMRB18BBD...	56413FIL	56419FIL	56425FIL
		DD = 270° back	HMRB18BDD...			
	B, C	AP, AD = 000° up	HMRB18BAP...			
	B, C	CP, CD = 180° down	HMRB18BCP...	50655FIL		
	R, S	AP, AD = 000° up	HMRB18RAP...	56413FIL		
HMRB-24	B, C, R, S	BD = 090° front	HMRB24BBD...	56414FIL	56416FIL	56427FIL
		DD = 270° back	HMRB24BDD...			
	B, C	AP, AD = 000° up	HMRB24BAP...			
	B, C	CP, CD = 180° down	HMRB24BCP...	56415FIL		
	R, S	AP, AD = 000° up	HMRB24RAP...	56414FIL		
R, S	CP, CD = 180° down	HMRB24RCP...				

							
Gear	Mounting kit	Servo motor	Motor cable	Resolver cable	Controller	Connector kit	
LP050		SMH60 60 1.4 8 11 S 2ID 65 4	MOK54/03	REK41/03	C3S 015 V4 F10 I11 T11 M00	ZBH02/02	
LP050		SMH82 60 03 8 14 S 2ID 65 4	MOK54/03	REK41/03	C3S 038 V4 F10 I11 T11 M00		
LP050		SMH60 60 1.4 8 11 S 2ID 65 4	MOK54/03	REK41/03	C3S 015 V4 F10 I11 T11 M00	ZBH02/02	
LP070		SMH82 60 03 8 14 S 2ID 65 4	MOK54/03	REK41/03	C3S 038 V4 F10 I11 T11 M00		
PS60-xxx-S2 RS60-xxx-S2	MU60-254	SMH60 60 1.4 8 11 S 2ID 65 4	MOK54/03	REK41/03	C3S 015 V4 F10 I11 T11 M00	ZBH02/02	
PS60-xxx-S2 RS60-xxx-S2	MU60-321	SMH82 60 03 8 14 S 2ID 65 4	MOK54/03	REK41/03	C3S 038 V4 F10 I11 T11 M00		
PS90-xxx-S2 RS90-xxx-S2	MU90-001	SMH82 60 03 8 14 S 2ID 65 4	MOK54/03	REK41/03	C3S 038 V4 F10 I11 T11 M00	ZBH02/02	
PS90-xxx-S2 RS90-xxx-S2	MU90-088	SMH100 56 06 5 19 S 2ID 65 4	MOK54/03	REK41/03	C3S 075 V4 F10 I11 T11 M00		
PS115-xxx-S2 RS115-xxx-S2	MU115-270	SMH100 56 06 5 19 S 2ID 65 4	MOK54/03	REK41/03	C3S 075 V4 F10 I11 T11 M00	ZBH02/02	
PS115-xxx-S2 RS115-xxx-S2	MU115-026	SMH115 56 10 5 24 S 2I 65 4	MOK57/03	REK41/03	C3S 150 V4 F10 I11 T11 M00		

Information:

The SMH motors can be also equipped with an absolut multturn encoder and/or holding brake for vertical applications. Shown cables are with 5 meter cable length. Other lengths on request.

## Parker Worldwide

### Europe, Middle East, Africa

#### AE – United Arab Emirates.

Dubai  
Tel: +971 4 8127100  
parker.me@parker.com

#### AT – Austria. Wiener Neustadt

Tel: +43 (0)2622 23501-0  
parker.austria@parker.com

#### AT – Eastern Europe. Wiener Neustadt

Tel: +43 (0)2622 23501 900  
parker.easteurope@parker.com

#### AZ – Azerbaijan. Baku

Tel: +994 50 2233 458  
parker.azerbaijan@parker.com

#### BE/LU – Belgium. Nivelles

Tel: +32 (0)67 280 900  
parker.belgium@parker.com

#### BY – Belarus. Minsk

Tel: +375 17 209 9399  
parker.belarus@parker.com

#### CH – Switzerland. Etoy

Tel: +41 (0)21 821 87 00  
parker.switzerland@parker.com

#### CZ – Czech Republic. Klecany

Tel: +420 284 083 111  
parker.czechrepublic@parker.com

#### DE – Germany. Kaarst

Tel: +49 (0)2131 4016 0  
parker.germany@parker.com

#### DK – Denmark. Ballrup

Tel: +45 43 56 04 00  
parker.denmark@parker.com

#### ES – Spain. Madrid

Tel: +34 902 330 001  
parker.spain@parker.com

#### FI – Finland. Vantaa

Tel: +358 (0)20 753 2500  
parker.finland@parker.com

#### FR – France. Contamine s/Arve

Tel: +33 (0)4 50 25 80 25  
parker.france@parker.com

#### GR – Greece. Athens

Tel: +30 210 933 6450  
parker.greece@parker.com

#### HU – Hungary. Budapest

Tel: +36 1 220 4155  
parker.hungary@parker.com

#### IE – Ireland. Dublin

Tel: +353 (0)1 466 6370  
parker.ireland@parker.com

#### IT – Italy. Corsico (MI)

Tel: +39 02 45 19 21  
parker.italy@parker.com

#### KZ – Kazakhstan. Almaty

Tel: +7 7272 505 800  
parker.easteurope@parker.com

#### NL – The Netherlands. Oldenzaal

Tel: +31 (0)541 585 000  
parker.nl@parker.com

#### NO – Norway. Asker

Tel: +47 66 75 34 00  
parker.norway@parker.com

#### PL – Poland. Warsaw

Tel: +48 (0)22 573 24 00  
parker.poland@parker.com

#### PT – Portugal. Leca da Palmeira

Tel: +351 22 999 7360  
parker.portugal@parker.com

#### RO – Romania. Bucharest

Tel: +40 21 252 1382  
parker.romania@parker.com

#### RU – Russia. Moscow

Tel: +7 495 645-2156  
parker.russia@parker.com

#### SE – Sweden. Spånga

Tel: +46 (0)8 59 79 50 00  
parker.sweden@parker.com

#### SK – Slovakia. Banská Bystrica

Tel: +421 484 162 252  
parker.slovakia@parker.com

#### SL – Slovenia. Novo Mesto

Tel: +386 7 337 6650  
parker.slovenia@parker.com

#### TR – Turkey. Istanbul

Tel: +90 216 4997081  
parker.turkey@parker.com

#### UA – Ukraine. Kiev

Tel: +380 44 494 2731  
parker.ukraine@parker.com

#### UK – United Kingdom. Warwick

Tel: +44 (0)1926 317 878  
parker.uk@parker.com

#### ZA – South Africa. Kempton Park

Tel: +27 (0)11 961 0700  
parker.southafrica@parker.com

### North America

#### CA – Canada. Milton. Ontario

Tel: +1 905 693 3000

#### US – USA. Cleveland

Tel: +1 216 896 3000

### Asia Pacific

#### AU – Australia. Castle Hill

Tel: +61 (0)2-9634 7777

#### CN – China. Shanghai

Tel: +86 21 2899 5000

#### HK – Hong Kong

Tel: +852 2428 8008

#### IN – India. Mumbai

Tel: +91 22 6513 7081-85

#### JP – Japan. Tokyo

Tel: +81 (0)3 6408 3901

#### KR – South Korea. Seoul

Tel: +82 2 559 0400

#### MY – Malaysia. Shah Alam

Tel: +60 3 7849 0800

#### NZ – New Zealand. Mt Wellington

Tel: +64 9 574 1744

#### SG – Singapore

Tel: +65 6887 6300

#### TH – Thailand. Bangkok

Tel: +662 186 7000-99

#### TW – Taiwan. Taipei

Tel: +886 2 2298 8987

### South America

#### AR – Argentina. Buenos Aires

Tel: +54 3327 44 4129

#### BR – Brazil. Sao Jose dos Campos

Tel: +55 800 727 5374

#### CL – Chile. Santiago

Tel: +56 2 623 1216

#### MX – Mexico. Apodaca

Tel: +52 81 8156 6000



#### Parker Hannifin GmbH

Pat-Parker-Platz 1  
41564 Kaarst (Germany)

Tel.: + 49 (0)2131 4016-0

Fax: + 49 (0)2131 4016-9199

Internet: www.parker.com

E-Mail: parker.germany@parker.com