



# **Hydraulic Cylinder HC20 Standard**

*Catalogue HY17-8117/UK  
November, 2002*



<b>Contents</b>	<b>Sida</b>
Component description .....	3
HC20T in standard version .....	4
HC20T with flange at piston-rod end .....	5
HC20T with flange at rear end .....	6
HC20T with trunnion .....	7
Calculation of force output and maximum permissible buckle load .....	8
Force output and buckle diagram .....	9
Technical data .....	10
Ordering formula .....	11

## Component description

- Compact cylinder for tough mobile operation and long service life.
- Easy to service using standard tools.
- Choice of material, mounting provisions, seals and surface treatment.

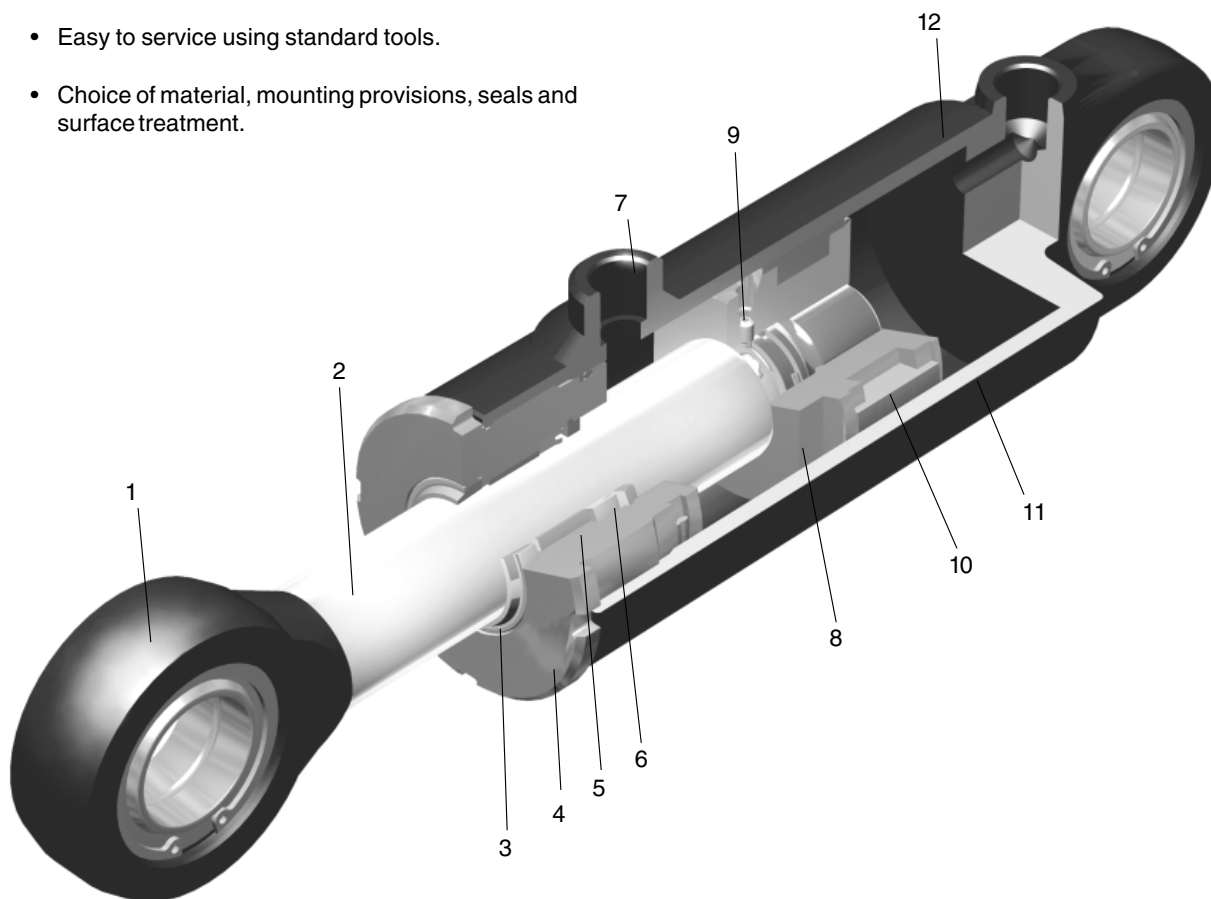

- |   |   |
|---|---|
| <ol style="list-style-type: none"> <li>1. Piston-rod eye with spherical plain bearing, or external thread.</li> <li>2. Alternative piston-rod materials and surface treatments.</li> <li>3. Efficient, wear-resistant wiper rings for normal operation, or for tough operation.</li> <li>4. Front cap threaded into cylinder barrel. In larger variants, the thread is sealed off by means of an O-ring to protect against corrosion. The cylinder cap has hook-spanner flats for easy disassembly.</li> <li>5. Bearing of fibre-reinforced Bakelite as standard, with capacity to take up large radial forces.</li> <li>6. Piston-rod seal of polyurethane with open seal groove and lock ring.</li> </ol> | <ol style="list-style-type: none"> <li>7. Connection ports with standard threads. Flat gasket.</li> <li>8. Spanner flat for standard tools on piston.</li> <li>9. Radial locking of piston by means of locking groove (no machining needed prior to assembly).</li> <li>10. Alternative compact piston-seals and bearing with standard installation dimensions for different kinds of operation.</li> <li>11. Cylinder barrel of high-grade, specially drawn steel, roller-burnished internally to Ra 0.6.</li> <li>12. Welded joints optimized for long service life.</li> </ol> |
|---|---|

## HC20T in standard version

Cylinder barrel type K - Piston-rod mounting provisions types K and U

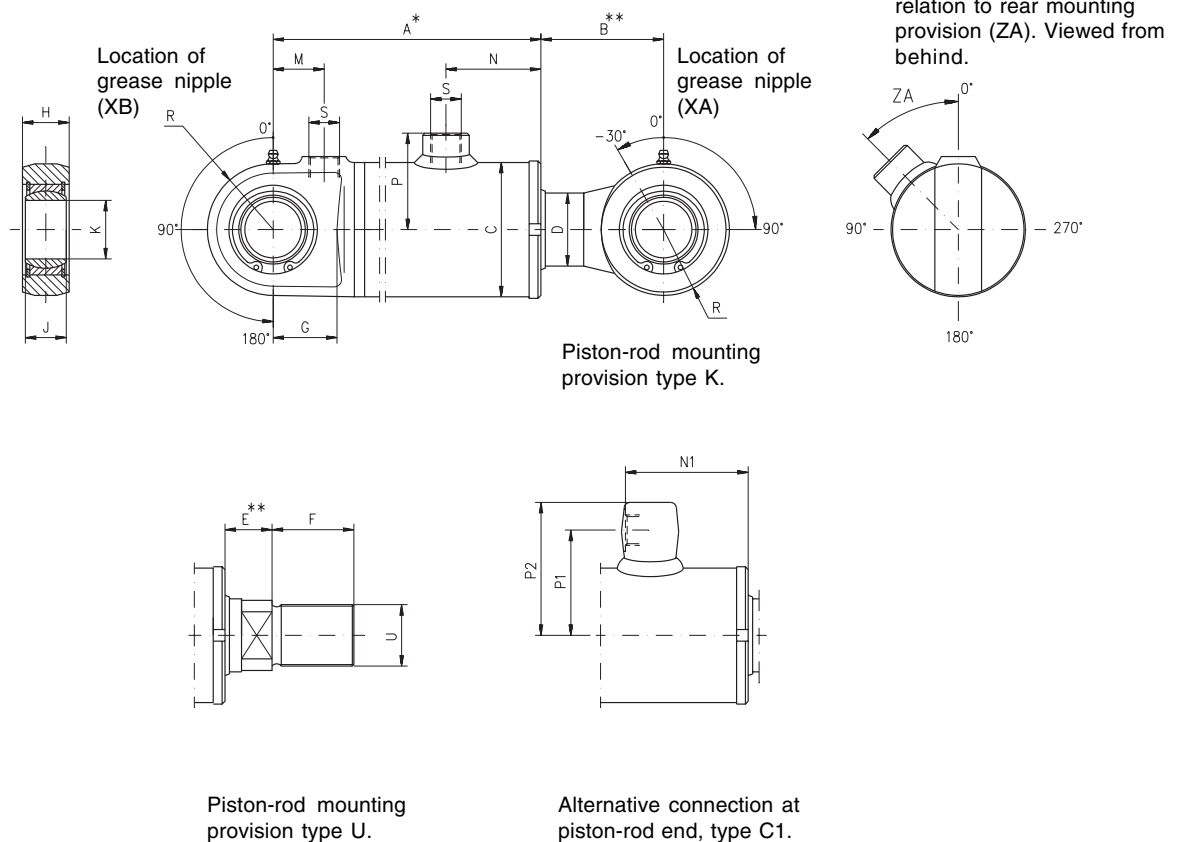

\* + stroke length + internal spacer, \*\* + piston-rod extension

Cyl. dim.	A	B	C Ø	D Ø	E	F	G	H	J	K Ø	M	N	N1	P	P1	P2	R	S	U
25- 12	107	29	32	12	15	16	15	14	10	12	26	33	50	28	35	45	16	G 1/4	M10x1,25
25- 16	128	29	32	16	15	18	15	14	10	12	26	54	71	28	35	45	16	G 1/4	M14x1,5
40- 20	142	40	50	20	19	22	25	18	16	20	37	52	70	38	46	58	25	G 3/8	M16x1,5
40- 25	142	40	50	25	19	28	25	18	16	20	37	52	70	38	46	58	25	G 3/8	M20x1,5
50- 25	159	46	60	25	23	28	33	25	20	25	34	58	77	50	56	75	30	G 1/2	M20x1,5
50- 32	159	46	60	32	23	36	33	25	20	25	34	58	77	50	56	75	30	G 1/2	M27x2
63- 32	163	54	73	32	27	36	40	28	22	30	34	61	80	57	63	82	36	G 1/2	M27x2
63- 40	163	54	73	40	27	45	40	28	22	30	34	61	80	57	63	82	36	G 1/2	M33x2
80- 40	174	66	92	40	28	45	45	32	28	40	35	65	84	66	72	91	45	G 1/2	M33x2
80- 50	174	66	92	50	28	56	45	32	28	40	35	65	84	66	72	91	45	G 1/2	M42x2
100- 50	208	82	115	50	29	56	64	40	35	50	55	78	97	80	84	103	60	G 3/4	M42x2
100- 63	208	82	115	63	29	63	64	40	35	50	55	78	97	80	84	103	60	G 3/4	M48x2
125- 63	233	92	145	63	38	63	72	50	44	60	60	90	109	95	99	118	70	G 3/4	M48x2
125- 80	233	92	145	80	38	85	72	50	44	60	60	90	109	95	99	118	70	G 3/4	M64x3
140- 70	304	105	160	70	42	75	80	60	49	70	80	105	134	107	120	145	80	G 1	M56x3
140- 90	304	105	160	90	42	90	80	60	49	70	80	105	134	107	120	145	80	G 1	M72x3
160- 80	337	118	184	80	42	85	90	75	55	80	117	102	131	120	132	157	90	G 1	M64x3
160-100	337	118	184	100	42	95	90	75	55	80	117	102	131	120	132	157	90	G 1	M80x3
180- 90	405	130	210	90	42	90	100	85	60	90	135	129	-	136	-	-	100	G 1 1/4	M72x3
180-110	405	130	210	110	42	105	100	85	60	90	135	129	-	136	-	-	100	G 1 1/4	M90x3
200-100	450	150	230	100	42	95	115	90	70	100	150	140	-	146	-	-	115	G 1 1/4	M80x3
200-125	450	150	230	125	42	112	115	90	70	100	150	140	-	146	-	-	115	G 1 1/4	M100x3



## HC20T with flange at piston-rod end

Cylinder barrel type Ga - Piston-rod mounting provisions types K and U

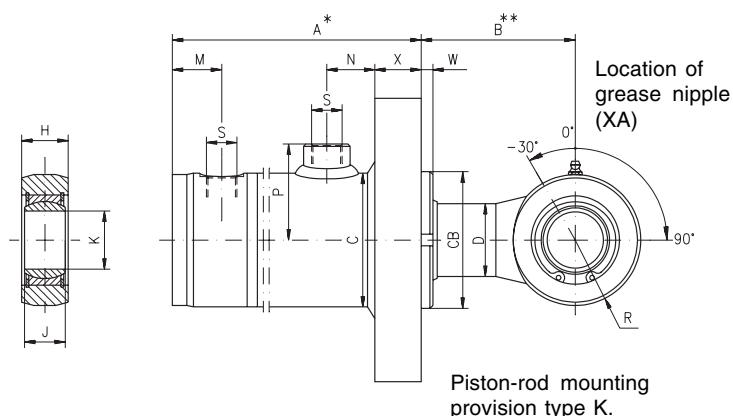

Location of front connection in relation to rear mounting provision (ZA). Viewed from behind.

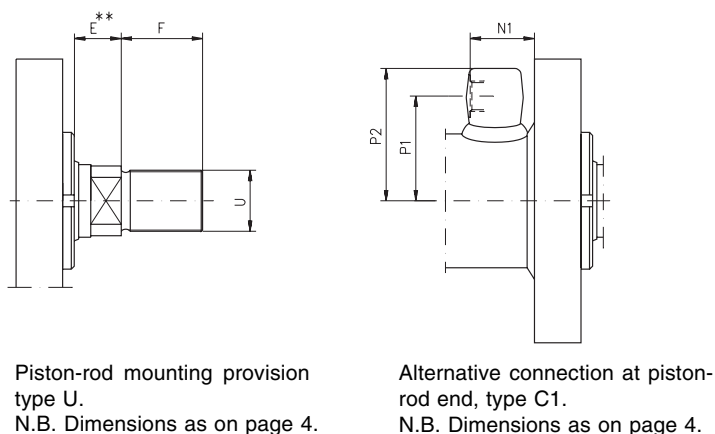
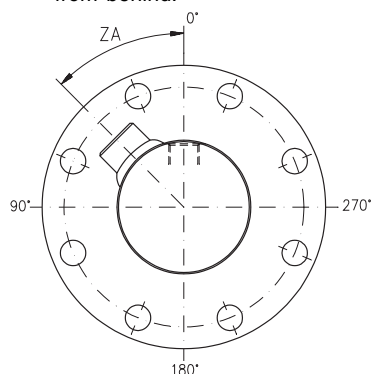

\* + stroke length + internal spacer, \*\* + piston-rod extension

Cyl. dim.	A	B	C Ø	CB Ø	D Ø	H	J	K Ø	M	N	P	R	S	W	X	FB Ø	FD Ø	UE Ø
25- 12	96	32	32	33	12	14	10	12	18	18	28	16	G 1/4	3	12	6,6	75	88
25- 16	96	53	32	33	16	14	10	12	18	18	28	16	G 1/4	24	12	6,6	75	88
40- 20	122	48	50	52	20	18	16	20	24	27	38	25	G 3/8	8	16	9	106	125
40- 25	122	48	50	52	25	18	16	20	24	27	38	25	G 3/8	8	16	9	106	125
50- 25	145	56	60	61	25	25	20	25	30	27	50	30	G 1/2	10	20	11	126	150
50- 32	145	56	60	61	32	25	20	25	30	27	50	30	G 1/2	10	20	11	126	150
63- 32	149	64	73	75	32	28	22	30	30	26	57	36	G 1/2	10	25	14	145	175
63- 40	149	64	73	75	40	28	22	30	30	26	57	36	G 1/2	10	25	14	145	175
80- 40	163	74	92	95	40	32	28	40	34	29	66	45	G 1/2	8	28	18	165	200
80- 50	163	74	92	95	50	32	28	40	34	29	66	45	G 1/2	8	28	18	165	200
100- 50	185	92	115	120	50	40	35	50	39	35	80	60	G 3/4	10	32	22	200	245
100- 63	185	92	115	120	63	40	35	50	39	35	80	60	G 3/4	10	32	22	200	245
125- 63	200	102	145	149	63	50	44	60	41	47	95	70	G 3/4	10	32	22	235	280
125- 80	200	102	145	149	80	50	44	60	41	47	95	70	G 3/4	10	32	22	235	280
140- 70	264	120	160	165	70	60	49	70	55	54	107	80	G 1	15	36	22	255	305
140- 90	264	120	160	165	90	60	49	70	55	54	107	80	G 1	15	36	22	255	305
160- 80	257	136	184	190	80	75	55	80	27	44	120	90	G 1	18	36	22	280	330
160-100	257	136	184	190	100	75	55	80	27	44	120	90	G 1	18	36	22	280	330
180- 90	285	150	210	215	90	85	60	90	35	63	136	100	G 1 1/4	20	46	26	320	370
180-110	285	150	210	215	110	85	60	90	35	63	136	100	G 1 1/4	20	46	26	320	370
200-100	319	175	230	235	100	90	70	100	35	69	146	115	G 1 1/4	25	46	26	340	390
200-125	319	175	230	235	125	90	70	100	35	69	146	115	G 1 1/4	25	46	26	340	390

## HC20T with flange at rear end

Cylinder barrel type Gb - Piston-rod mounting provisions types K and U

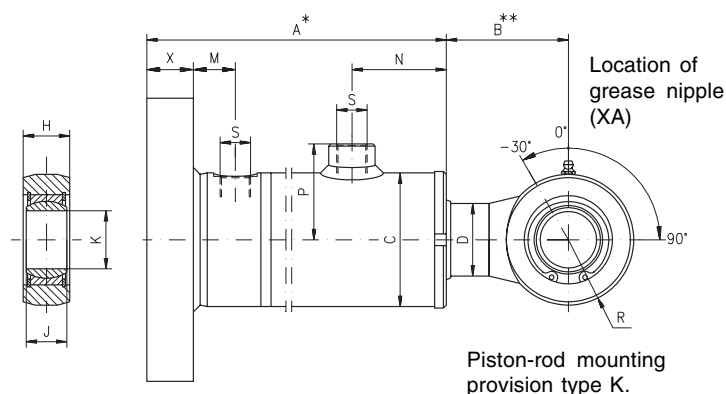

Location of front connection in relation to rear mounting provision (ZA). Viewed from behind.

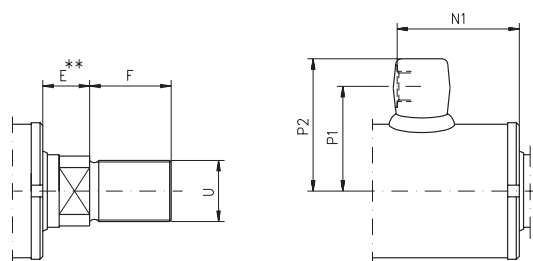
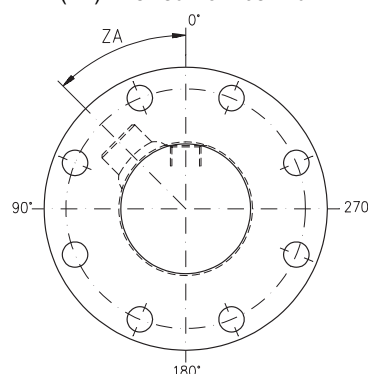

Piston-rod mounting provision type U.  
 N.B. Dimensions as on page 4.

Alternative connection at piston-rod end, type C1.  
 N.B. Dimensions as on page 4.

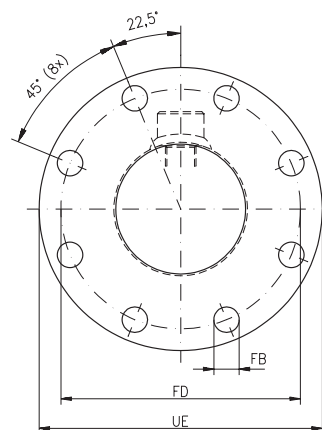

\* + stroke length + internal spacer, \*\* + piston-rod extension

Cyl dim	A	B	C Ø	D Ø	H	J	K Ø	M	N	P	R	S	X	FB Ø	FD Ø	UE Ø
25- 12	108	29	32	12	14	10	12	15	33	28	16	G 1/4	12	6,6	75	88
25- 16	129	29	32	16	14	10	12	15	54	28	16	G 1/4	12	6,6	75	88
40- 20	143	40	50	20	18	16	20	21	52	38	25	G 3/8	16	9	106	125
40- 25	143	40	50	25	18	16	20	21	52	38	25	G 3/8	16	9	106	125
50- 25	172	46	60	25	25	20	25	27	58	50	30	G 1/2	20	11	126	150
50- 32	172	46	60	32	25	20	25	27	58	50	30	G 1/2	20	11	126	150
63- 32	181	54	73	32	28	22	30	27	61	57	36	G 1/2	25	14	145	175
63- 40	181	54	73	40	28	22	30	27	61	57	36	G 1/2	25	14	145	175
80- 40	194	66	92	40	32	28	40	30	65	66	45	G 1/2	28	18	165	200
80- 50	194	66	92	50	32	28	40	30	65	66	45	G 1/2	28	18	165	200
100- 50	222	82	115	50	40	35	50	36	78	80	60	G 3/4	32	22	200	245
100- 63	222	82	115	63	40	35	50	36	78	80	60	G 3/4	32	22	200	245
125- 63	237	92	145	63	50	44	60	36	90	95	70	G 3/4	32	22	235	280
125- 80	237	92	145	80	50	44	60	36	90	95	70	G 3/4	32	22	235	280
140- 70	307	105	160	70	60	49	70	47	105	107	80	G 1	36	22	255	305
140- 90	307	105	160	90	60	49	70	47	105	107	80	G 1	36	22	255	305
160- 80	303	118	184	80	75	55	80	47	102	120	90	G 1	36	22	280	330
160-100	303	118	184	100	75	55	80	47	102	120	90	G 1	36	22	280	330
180- 90	370	130	210	90	85	60	90	54	129	136	100	G 1 1/4	46	26	320	370
180-110	370	130	210	110	85	60	90	54	129	136	100	G 1 1/4	46	26	320	370
200-100	400	150	230	100	90	70	100	54	140	146	115	G 1 1/4	46	26	340	390
200-125	400	150	230	125	90	70	100	54	140	146	115	G 1 1/4	46	26	340	390

## HC20T with trunnion

Cylinder barrel type V - Piston-rod mounting provisions types K and U

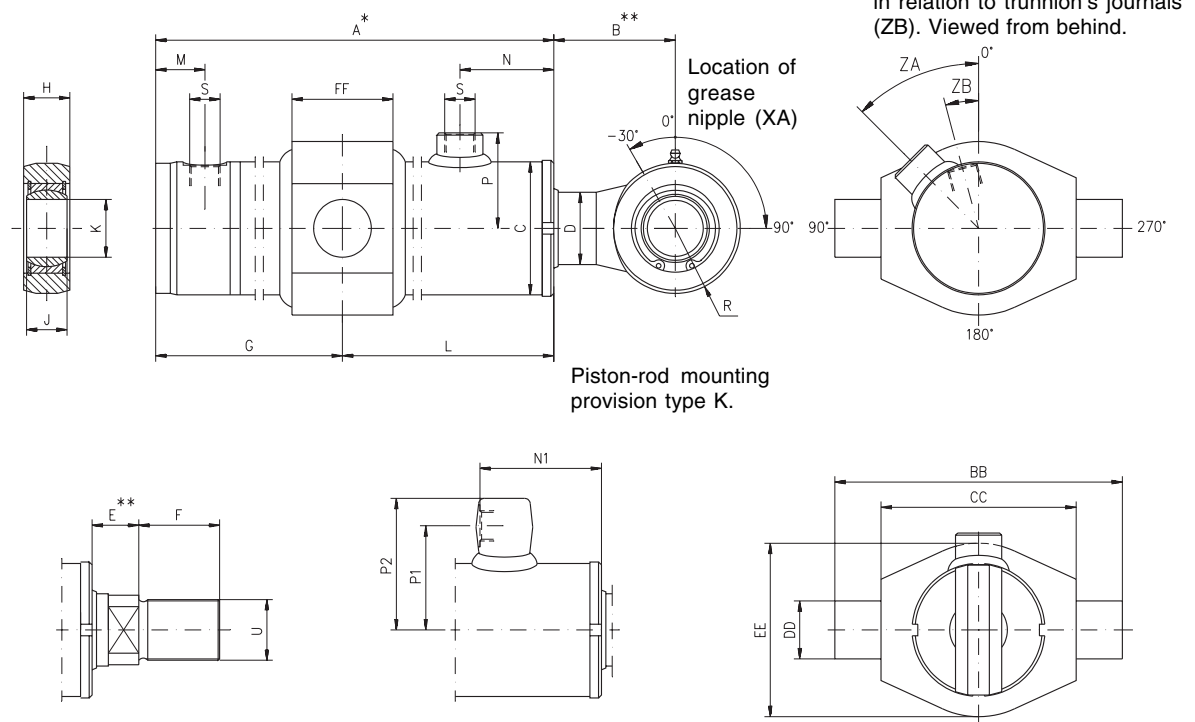

Location of front connection in relation to trunnion's journals (ZA). Location of rear connection in relation to trunnion's journals (ZB). Viewed from behind.

Piston-rod mounting provision type K.

Piston-rod mounting provision type U.  
 N.B. Dimensions as on page 4.

Alternative connection at piston-rod end, type C1.  
 N.B. Dimensions as on page 4.

\* + stroke length + internal spacer, \*\* + piston-rod extension

Cyl dim	L min	A	B	C Ø	D Ø	G min	H	J	K Ø	M	N	P	R	S	BB	CC	DD Ø	EE	FF
25- 12	74	99	29	32	12	60	14	10	12	18	33	28	16	G 1/4	83	63	12	46	25
25- 16	95	120	29	32	16	60	14	10	12	18	54	28	16	G 1/4	83	63	12	46	25
40- 20	100	130	40	50	20	78	18	16	20	24	52	38	25	G 3/8	107	75	20	66	40
40- 25	100	130	40	50	25	78	18	16	20	24	52	38	25	G 3/8	107	75	20	66	40
50- 25	113	155	46	60	25	90	25	20	25	30	58	50	30	G 1/2	145	105	25	78	40
50- 32	113	155	46	60	32	90	25	20	25	30	58	50	30	G 1/2	145	105	25	78	40
63- 32	123	159	54	73	32	95	28	22	30	30	61	57	36	G 1/2	170	120	32	96	50
63- 40	123	159	54	73	40	95	28	22	30	30	61	57	36	G 1/2	170	120	32	96	50
80- 40	137	171	66	92	40	105	32	28	40	34	65	66	45	G 1/2	199	135	40	120	65
80- 50	137	171	66	92	50	105	32	28	40	34	65	66	45	G 1/2	199	135	40	120	65
100- 50	178	195	82	115	50	125	40	35	50	39	78	80	60	G 3/4	240	160	50	144	80
100- 63	178	195	82	115	63	125	40	35	50	39	78	80	60	G 3/4	240	160	50	144	80
125- 63	192	210	92	145	63	150	50	44	60	41	90	95	70	G 3/4	295	195	60	184	90
125- 80	192	210	92	145	80	150	50	44	60	41	90	95	70	G 3/4	295	195	60	184	90
140- 70	225	279	105	160	70	176	60	49	70	55	105	107	80	G 1	340	220	70	200	120
140- 90	225	279	105	160	90	176	60	49	70	55	105	107	80	G 1	340	220	70	200	120
160- 80	235	275	118	184	80	170	75	55	80	27	102	120	90	G 1	366	240	80	230	140
160-100	235	275	118	184	100	170	75	55	80	27	102	120	90	G 1	366	240	80	230	140
180- 90	280	305	130	210	90	195	85	60	90	35	129	136	100	G 1 1/4	420	280	90	250	160
180-110	280	305	130	210	110	195	85	60	90	35	129	136	100	G 1 1/4	420	280	90	250	160
200-100	305	370	150	230	100	245	90	70	100	35	140	146	115	G 1 1/4	455	295	100	280	180
200-125	305	370	150	230	125	245	90	70	100	35	140	146	115	G 1 1/4	455	295	100	280	180



## Calculation of force output and maximum permissible buckle load

Permissible buckle load

$$F_{kt} = \frac{\pi^2 \cdot E \cdot I}{n \cdot L_f^2} \quad *$$

$F_{kt}$  = permissible buckle load (N)  
 $E$  = elasticity module (210000 N/mm<sup>2</sup>)  
 $I$  = moment of inertia (mm<sup>4</sup>)  
 $L_f$  = free buckle length (mm)  
 $n$  = safety factor

\* applies when  $89 \leq \lambda \leq 200$

$$\lambda = \frac{4L_f}{d}$$

Cylinder's force output

$$F = \frac{\pi \cdot D^2}{4} \cdot P$$

$F$  = cylinder's force output (N)  
 $D$  = cylinder bore diameter (mm)  
 $P$  = system pressure (MPa)

(1 MPa = 10 bar)

Moment of inertia

$$I = \frac{\pi \cdot d^4}{64}$$

$d$  = piston rod diameter (mm)

Case 1

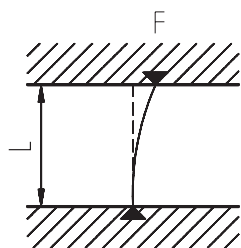

$$L_f = 2,1 \cdot L$$

Case 2

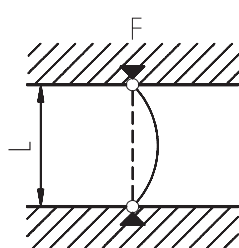

$$L_f = L$$

Case 3

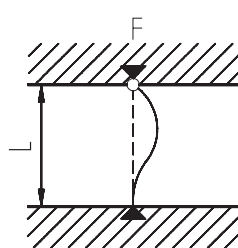

$$L_f = 0,8 \cdot L$$

Case 4

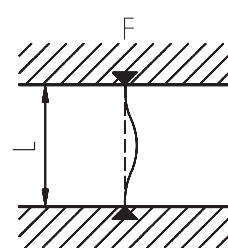

$$L_f = 0,6 \cdot L$$

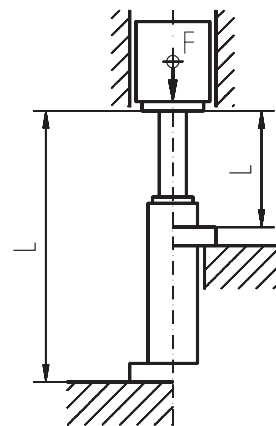
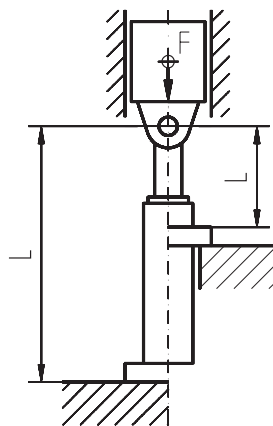
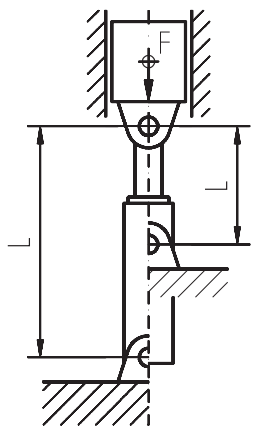
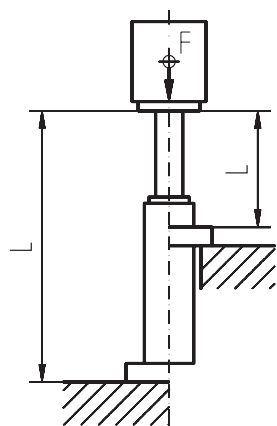

## Force output and buckle diagram

### Force output and buckling

Example: Load (point A in diagram) 100 kN and system pressure (B) 20 MPa gives cylinder bore diameter of 80 mm. Load (A) 100 kN and cylinder's max. length (C) 1.6 m gives piston rod > 50 mm but < 63 mm. Choose 63 mm piston rod.

### Buckle length (equivalent buckle length)

Example: Case 2, free buckle length  $L_f = L = 1600$  mm  
 Case 3, free buckle length  $L_f = 0.8 L = 0.8 \cdot 1600 = 1280$  mm  
 - which gives piston rod diameter of 50 mm.

N.B. The purpose of the table is only to give guiding values for buckling, according to Euler, and does not take into consideration, e.g. dynamic loads, initial bendings and radial loads which can influence buckling and service life. When there are very high demands on service life and/or when one is close to limit values, please consult Parker for more detailed calculation.

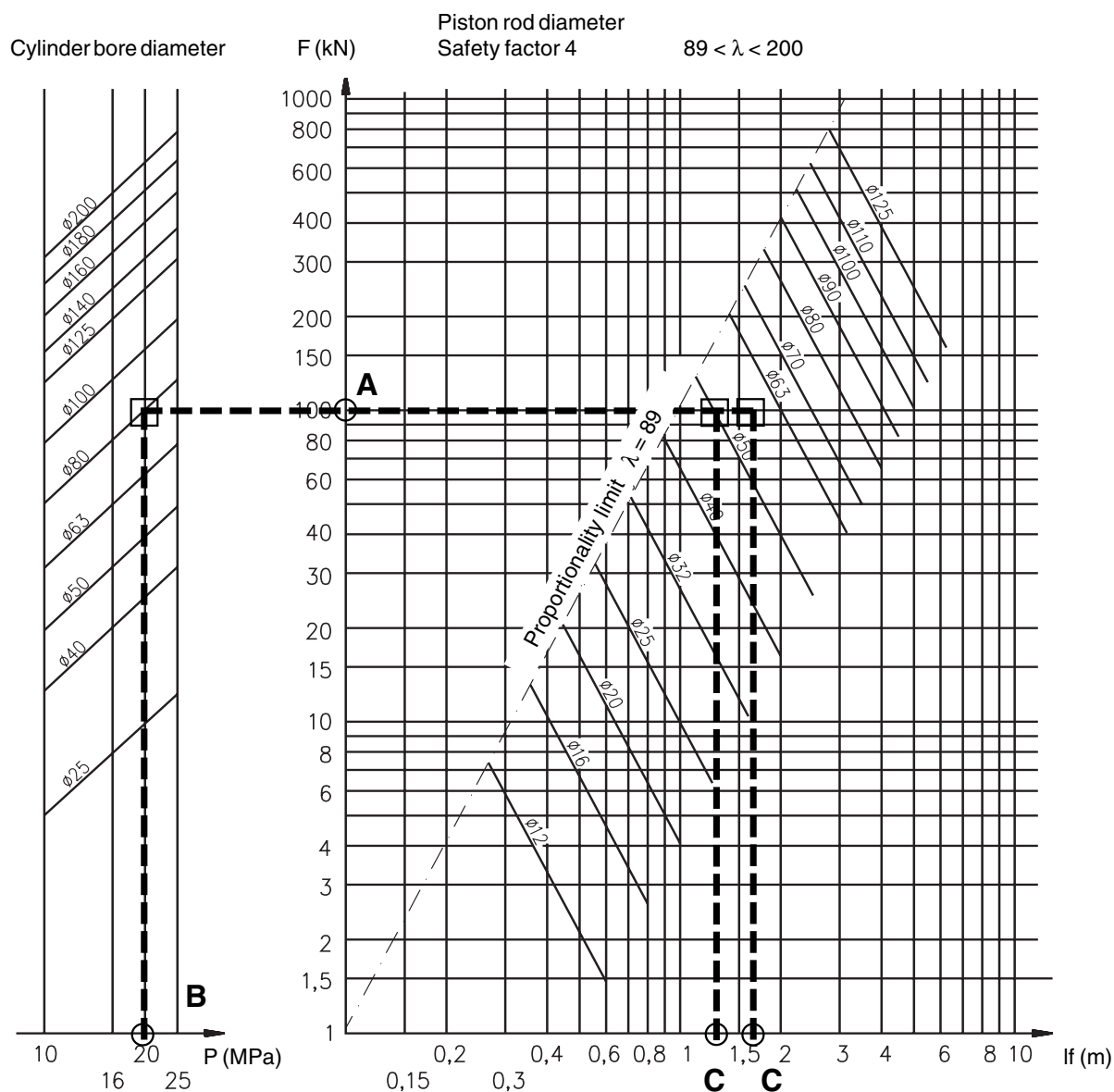

## Technical data

Cyl.dim	Cylinder weight HC20T	
	with normal rod	with oversize rod
mm	kg	kg
25	0,8 + 0,0034 x SL	0,9 + 0,0040 x SL
40	2,4 + 0,0080 x SL	2,5 + 0,0094 x SL
50	3,5 + 0,0106 x SL	3,7 + 0,0131 x SL
63	5,3 + 0,0138 x SL	5,5 + 0,0174 x SL
80	7,5 + 0,0226 x SL	7,9 + 0,0280 x SL
100	17,0 + 0,0353 x SL	17,5 + 0,0444 x SL
125	32,6 + 0,0542 x SL	33,1 + 0,0690 x SL
140	58,0 + 0,0672 x SL	58,5 + 0,0870 x SL
160	76,0 + 0,0814 x SL	76,7 + 0,1036 x SL
180	120,0 + 0,1220 x SL	120,0 + 0,1467 x SL
200	190,0 + 0,1412 x SL	121,0 + 0,1758 x SL

SL = stroke length in mm

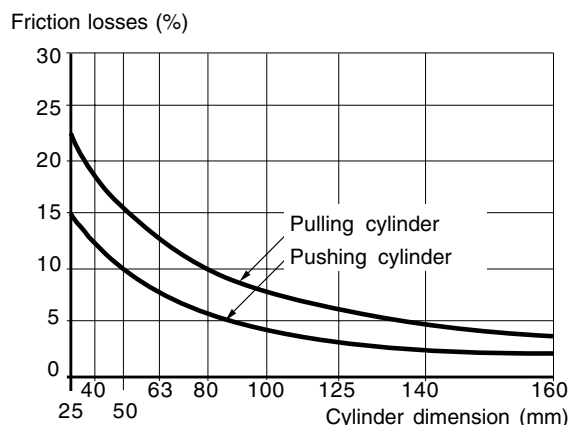

The diagram shows approximate values for friction losses at 10 MPa (100 bar) and a piston velocity of 0.2 m/s.

**Working pressure** 16 MPa (160 bar) in continuous operation  
 25 MPa (250 bar) intermittent  
 Test pressure 30 MPa (300 bar)

**Working temperature** -30° C to +80° C in normal operation. Refers to seals in standard version.

**Piston rod material** Standard SS 14 2142, hard chromium plated 25 µm.  
 Variant; NC SS 14 2142, NiCr 350 40 µm.  
 Variant; RC SS 14 2324, stainless steel, hard chromium plated 25 µm.  
 Variant; HC SS 14 1672, hardened HRC 58, hard chromium plated 25 µm.

**Connections** Connections are planed for flat gasket.

**Spherical plain bearing** Mounting journals in the spherical plain bearing should be of SS 14 2541 material, diameter tolerance m6. The spherical plain bearing should be greased periodically with rust-inhibiting lithium grease type EP with molybdenum disulphide additive.

**Stroke length** Max. 2800 mm. In cylinders with long stroke length, an internal spacer bushing may be needed to reduce bearing load on piston and piston rod. The installation dimensions of the cylinder for a given stroke length can be increased by extending the piston rod, or by means of an internal spacer bushing.

**Velocity** Piston velocity max. 0.6 m/s.

**Tolerances** Journal tolerance for linkage eye type K: m6  
 Tolerance for trunnion journals: f8

**Hydraulic fluid** Mineral base oil. Target Contamination Class: ISO-DIS 4406 16/13.  
 Synthetic, fire-resistant and environmentally friendly oils can also be used. If in doubt about the suitability of an oil, please contact your nearest Parker Hannifin representative for information.

**When standard version not sufficient** If the technical data above does not meet your specifications, please consult Parker for tailor-made solutions.

**Parker reserves the right to make technical modifications without prior notice.**



## Ordering formula

Example: 

HC20T	K	100	C1	50	K	NC	400	D100	F50	ZA20	/	XBM80	XAM90	/	A03
1	2	3	4	5	6	7	8	11	12	13	14	15	16	17	18

Order: 

--	--	--	--	--	--	--	--	--	--	--	--	--	--	--	--

<b>1</b>	<b>Cylinder type</b>
	HC20T Threaded front cylinder-cap.

<b>2</b>	<b>Barrel type, mounting versions</b>
	K Barrel with spherical plain bearing.
	V Barrel with trunnion.
	GA Barrel with front flange-mounting.
	GB Barrel with rear flange-mounting.

<b>3</b>	<b>Barrel bore diameter</b>
	Dimension (25-200 mm), see tables on pages 4-7.

<b>4</b>	<b>Connection type, piston-rod end</b>
	Straight
	C1 Angled

<b>5</b>	<b>Piston rod diameter</b>
	Dimension (12-125 mm), see tables on pages 4-7.

<b>6</b>	<b>Piston rod type</b>
	K Piston rod with spherical plain bearing.
	U Piston rod with external thread.

<b>7</b>	<b>Piston rod material</b>
	Standard SS 14 2142, hard chromium plated 25 µm.
	NC Ni-chrome, SS 14 2142, NiCr 350, nickel 40 µm, chrome 20 µm.
	RC Stainless steel, SS 14 2324, hard chromium plated 25 µm.
	HC Induction hardened steel, SS 14 1672, HRC 58, hard chromium plated 25 µm.

<b>8</b>	<b>Stroke length</b>
	Effective stroke length: max. 2800 mm.

<b>11</b>	<b>Internal spacer, D</b>
	Spacer length in mm.

<b>12</b>	<b>Piston rod extension, F</b>
	Extension in mm.

<b>13</b>	<b>Location of front connection, ZA</b>
	Location of front connection in relation to rear mounting. 0°-355° in 5° intervals.

<b>14</b>	<b>Location of rear connection, ZB</b> <b>Version V only.</b>
	Location of rear connection in relation to rear mounting (trunnion). 0°-355° in 5° intervals.

<b>15</b>	<b>Grease nipple, barrel eye</b>
	XBM M6 Location of grease nipple on barrel eye
	XBG G 1/8 0°-180° in 5° intervals.

<b>16</b>	<b>Grease nipple, piston-rod eye</b>
	XAM M6 Location of grease nipple on piston-rod eye
	XAG G 1/8 -30° - +90° in 5° intervals.

<b>17</b>	<b>Axial location of trunnion, L</b>
	L - - - Dimension L, see table on page 7.

<b>18</b>	<b>A-variants</b>
	A - - - Choose variant from A-variant list according to cylinder type.

We hereby order: \_\_\_\_\_ off hydraulic cylinders according to above specification.

Required delivery time: \_\_\_\_\_

Date: \_\_\_\_\_ Signature: \_\_\_\_\_

Company: \_\_\_\_\_ Customer Number: \_\_\_\_\_

Orderer: \_\_\_\_\_

Delivery address: \_\_\_\_\_

Postal address: \_\_\_\_\_

Telephone No: \_\_\_\_\_

Telefax No: \_\_\_\_\_

*Please make a copy of this page, complete form below and send to your local Parker representative.*



---

Please contact our sales representative:



**Parker Hannifin AB**  
Cylinder Division Europe  
P.O. Box 753  
SE-521 22 Falköping  
Sweden  
Tel +46 515 67 42 00  
Fax +46 515 67 42 22  
[www.parker.com](http://www.parker.com)

Catalogue HY17-8117/UK  
Ed. 0248