

# SCLSD LevelController

## Device features

- Proven measuring system
- Level display
- mm / inch / % display
- High and low display
- Analogue output
- Switching outputs
- No surge pipe necessary
- Replacement for several mechanical switches
- Pivoting

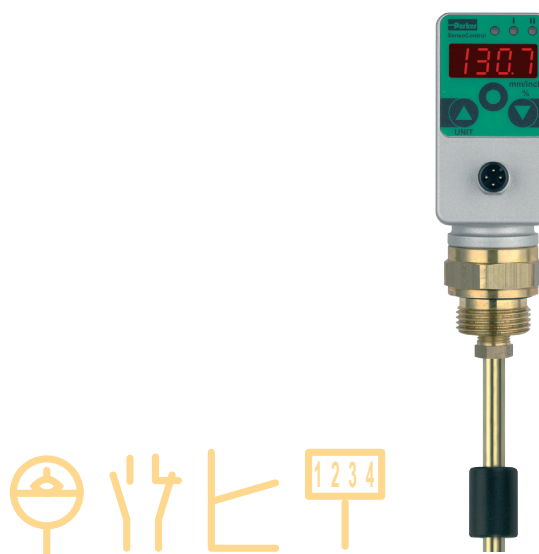

The LevelController combines the functions of a level switch, a level sensor and a level display.

- Level display (inspection glass)
- Switching outputs
- Analogue signal

The LevelController is ideal for the monitoring tank contents.

### Easy to use

The parameters are set using the keys or over a programming module.

### High functionality

Each switching output can be adjusted individually:

- NO/NC contact
- Upper and lower level switching point
- Delay times
- Hysteresis / window function
- Attenuation

The analogue output is individually adjustable:

- 0/4...20 mA switchable
- Upper level adjustable
- Lower level adjustable

### Reliable and safe

The position of the float is finely ( $\geq 5$  mm) and continuously recorded and shown in the display in mm or inch. Through this continuous recording, the danger of individual mechanical contacts "sticking" no longer exists. Therefore the operational reliability of the monitored plant is increased. Parameters can be password protected to avoid unauthorised changes.

### Everything at a glance

The display can be read from long distances. Using the selectable percent display the full level is uniformly displayed independent of the tank shape. An offset can also be entered (difference from the sensor to the tank bottom) to give a realistic indication of the level from the tank bottom.

Different uses can easily be implemented or corrected at a later date using the menu-driven level switching points. As the switching point no longer needs to be specified at the time of order, the versions of mechanical level switches required is reduced.

### Universal

Thanks to these easy switching functions (hysteresis and window functions, NC or NO functions), intelligent adjustments can be set which are normally not possible using a mechanical level switch. Therefore, many switches can be replaced with one controller. With the optional analogue output, the level and temperature can be monitored easily with a controller (e.g. for leakage monitoring).

# SCLSD LevelController

## Application example: Tank temperature monitoring

Since the conventional specifications for mechanical level switches (the mm data from the tank lid) are often used during project planning, these data are selected here for a practical example.

### Facility off

If the tank level falls below 310 mm (measured from the tank top / dry run) or climbs above 70 mm (measured from the tank top / overflow), switch off should occur. A protective wire-break mechanism should be considered to improve safety.

### Automatic tank filling

If the tank level falls below 240 mm (measured from the tank top), the tank should be automatically filled to 110 mm (measured from the tank top) with a pump.

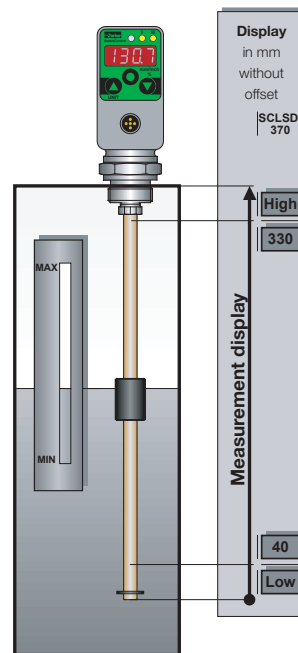

### Resulting switch value for a SCLSD-370 mm

Stop above:  
370 mm - 70 mm = 300 mm  
Stop below:  
370 mm - 310 mm = 60 mm  
Window function, NO contact

The output S1 is closed, if the level is between 300 and 60 mm.

Load stop:  
370 mm - 110 mm = 260 mm  
Load on:  
370 mm - 240 mm = 130 mm  
Hysteresis function, NC contact

If the level falls below 130 mm, the contact closes and opens again when 260 mm is exceeded.

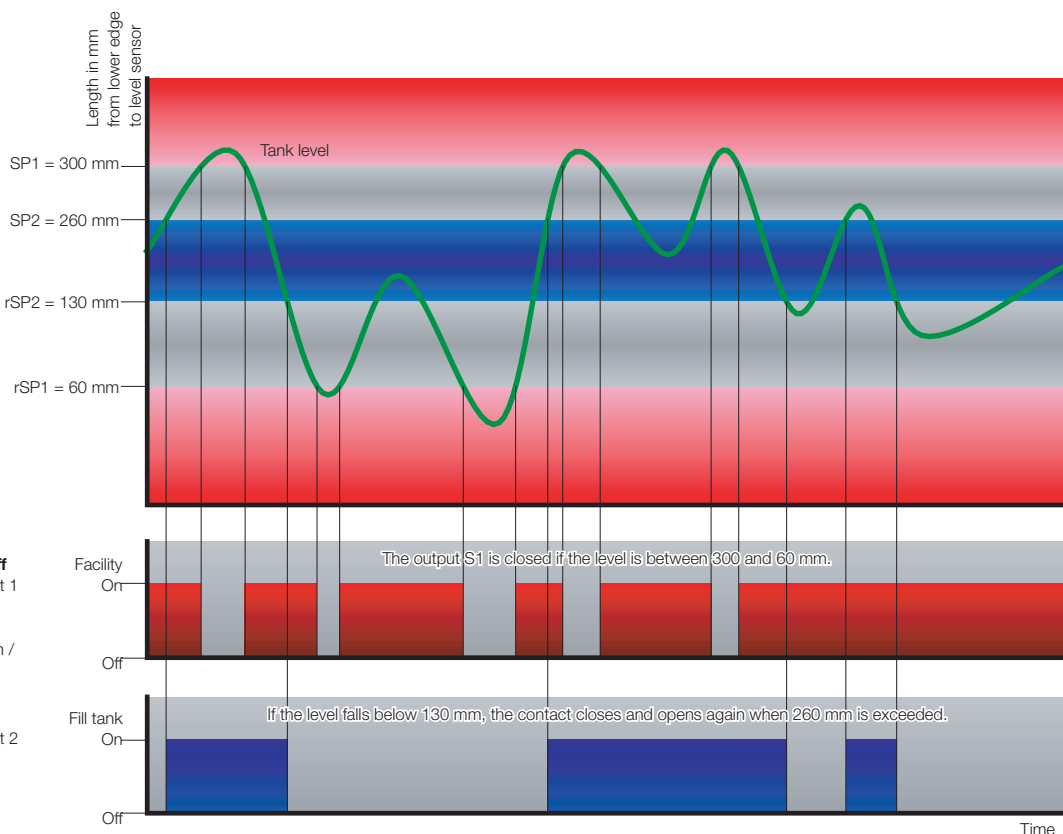

**Facility On / Off**  
Switching output 1  
SP1 = 300 mm  
rSP1 = 60 mm  
Window function /  
NO contact

**Fill tank**  
Switching output 2  
SP2 = 260 mm  
rSP2 = 130 mm  
Hysteresis NC  
contact

# SCLSD LevelController

## Device features

### Everything at a glance

- Sloped display
- Digital display
  - Large
  - Illuminated
- Display
  - mm, inch, or %
  - Actual level
  - High and low display
  - Switching points

### Rugged

- Metal housing
- Waterproof
- Excellent interference immunity
- Vibration proof
- Shock proof

### Variable installation

- Compact size
- 290° pivotable
- G3/4 BSPP
- Flange for DIN

### Programming module

- Adjustable with ControllerWIN Software

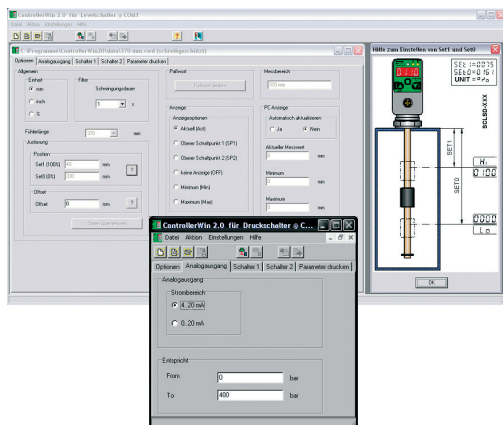

### Optical interface

- Switch status is shown

### Easy to use

- 3 large buttons
- Display of the unit

### Connect as required

- 2 switching outputs
- Analogue output
- 0...20 or 4...20 mA
- Freely programmable
- Scalable
- M12 connecting plugs



### No surge pipe necessary

- Electronic attenuation adjustable attenuation

### Proven measuring system

- High float dynamics
- Small design
- Universal usage

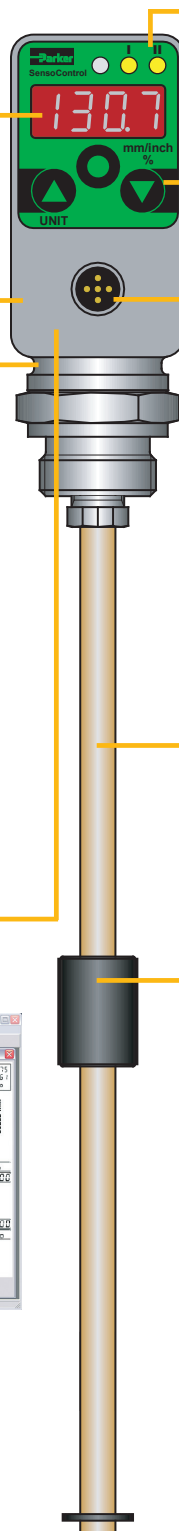

The Controller Family



# SCLSD LevelController

## Technical data

Input parameters	
Measuring component	Resistance reed chain with float
Connector thread	G3/4 BSPP; nickel-plated brass; ED soft seal NBR*
Parts in contact with substances	Brass; nickel-plated brass; NBR*
Temperature range of substance	-20...+85 °C
Output values	
Switching point accuracy	± 1 % FS at 25 °C
Display accuracy	± 1 % FS ± 1 Digit at 25 °C
Response speed	≤ 700 ms
Resolution	7.5 mm
Float	
Material	NBR
Dimensions	Ø 18 mm, Length 35 mm
Viscosity	Max. 250 cSt at 25 °C
Density	at least 0.750 g/cm <sup>3</sup>
Level rod	
Material	Stainless steel
Dimensions	Ø 8 mm
Operating pressure	1 bar
Electrical connection	
Supply voltage V <sub>+</sub>	15...30 VDC nominal 24 VDC; Protection class 3
Electrical connection	M12x1; 4-pole; 5-pole; with gold-plated contacts
Short-circuit protection	Yes
Protection against wrong insertion	Yes
Overload protection	Yes
Current consumption	< 100 mA

Housing	
	Adjustable direction to 290°C
Material	Die-cast zinc Z 410; painted
Foil material	Polyester
Display	4-digit 7-segment LED; red; digit height 9 mm
Protection degree	IP67 DIN EN 60529
Ambient conditions	
Ambient temperature range	-20...+85 °C
Storage temperature range	-40...+100 °C
EM compatibility	
Disturbance emissions	EN 61000-6-3
Resistance to interference	EN 61000-6-2
Outputs	
Switching outputs	Two MOSFET high-side switches (PNP)
Contact functions	NO / NC contact; window / hysteresis function freely adjustable
Switching voltage	V <sub>+</sub> - 1.5 VDC
Switching current max.	0.5 A per switch
Short-circuit current	2.4 A per switch
Analogue output	0/4...20 mA; programmable; freely scalable RL ≤ (power supply - 8 V) / 20 mA (≤ 500 Ω)

\* different sealing material (FKM, EPDM etc.) upon request

# SCLSD LevelController

## Display possibilities

Example of a percent display

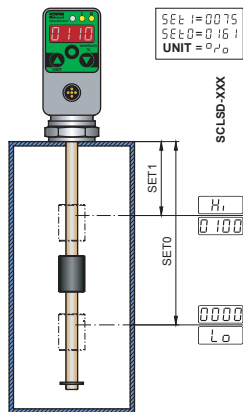

Example of a mm display

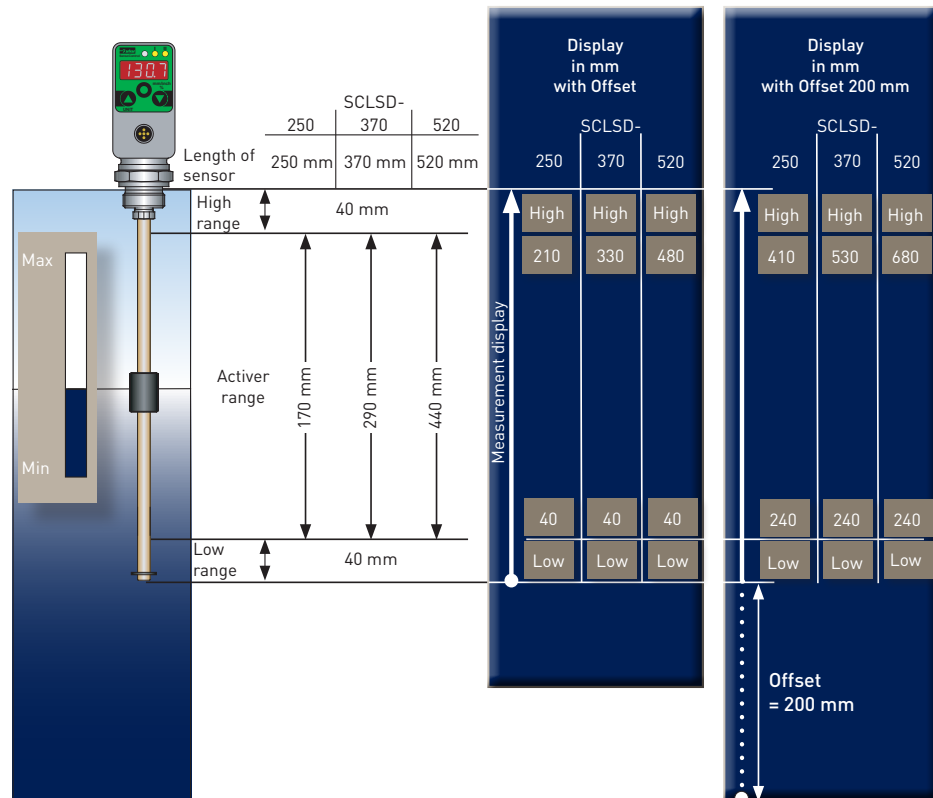

L1 Sensor length Measurement range	L2 active range	Display resolution Increment size	Incre- ment size	Lowest reset switch point RSP	Largest switch- ing value SP	Smallest adjustable difference between SP and RSP (SP-RSP)
250 mm	40...210 mm	1 mm	5 mm	40 mm	210 mm	5 mm
370 mm	40...330 mm	1 mm	5 mm	40 mm	330 mm	5 mm
520 mm	40...480 mm	1 mm	5 mm	40 mm	480 mm	5 mm
800 mm	40...760 mm	1 mm	10 mm	40 mm	760 mm	10 mm
1000 mm	40...960 mm	1 mm	10 mm	40 mm	960 mm	10 mm

## Pin assignment

### SCLSD-xxx-00-07

2 switching outputs; M12x1; 4-pole

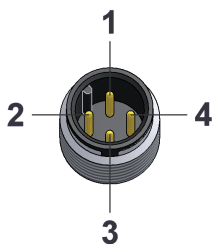

PIN	Assignment
1	V <sub>+</sub>
2	S2 out
3	0 V / GND
4	S1 out

### SCLSD-xxx-10-07

1 switching output, 1 analogue output, M12x1; 4-pole

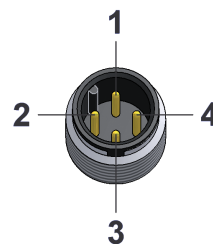

PIN	Assignment
1	V <sub>+</sub>
2	Analogue out
3	0 V / GND
4	S1 out



# SCLSD LevelController

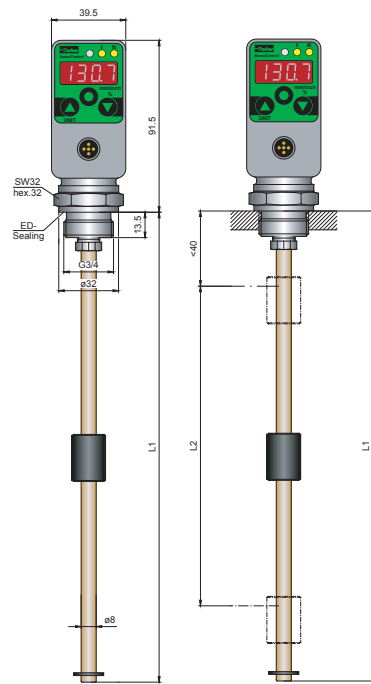

L1 = length of the sensor (mm)  
L2 = active range (mm)

## Order code

**SCLSD LevelController**  
**2 switching outputs;**  
**2 switching outputs Marine;**  
 (approved by DNV/GL/ABS)  
**no analogue output**  
 M12x1 connecting plug; 4-pole

SCLSD-xxx-00-07  
 SCLSD-xxx-00-07-MA

**1 switching output;**  
**1 switching output Marine;**  
 (approved by DNV/GL/ABS)  
**with analogue output**  
 M12x1 connecting plug; 4-pole

SCLSD-xxx-10-07  
 SCLSD-xxx-00-07-MA

**2 switching outputs;**  
**2 switching outputs Marine;**  
 (approved by DNV/GL/ABS)  
**with analogue output**  
 M12x1 connecting plug; 5-pole

SCLSD-xxx-10-05  
 SCLSD-xxx-10-05-MA

### Length (Installation length L1 mm)

250 mm	250
370 mm	370
520 mm	520
800 mm	800
1000 mm	1000

## Accessories

**PC Programming Kit**

SCSD-PRG-KIT

**Flange adapter**

SCAF-3/4-90

6-hole connection DIN 24557, part 2

## Connection cable and single plug

**Connection cable, assembled**

SCK-400-xx-xx

(open cable end)

### Cable length (m)

2 m	02
5 m	05
10 m	10

### Connecting plug

M12 cable jack; straight	45
M12 cable jack; 90° angled	55

### Single connector

M12 cable jack; straight	SCK-145
M12 cable jack; 90° angled	SCK-155

The Controller Family

### SCLSD-xxx-10-05

2 switching outputs, 1 analogue output  
 M12x1; 5-pole

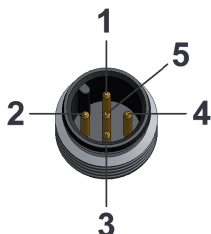

PIN	Assignment
1	V+
2	S2 out
3	0 V / GND
4	S1 out
5	Analogue out

