

aerospace
climate control
electromechanical
filtration
fluid & gas handling
hydraulics
pneumatics
process control
sealing & shielding

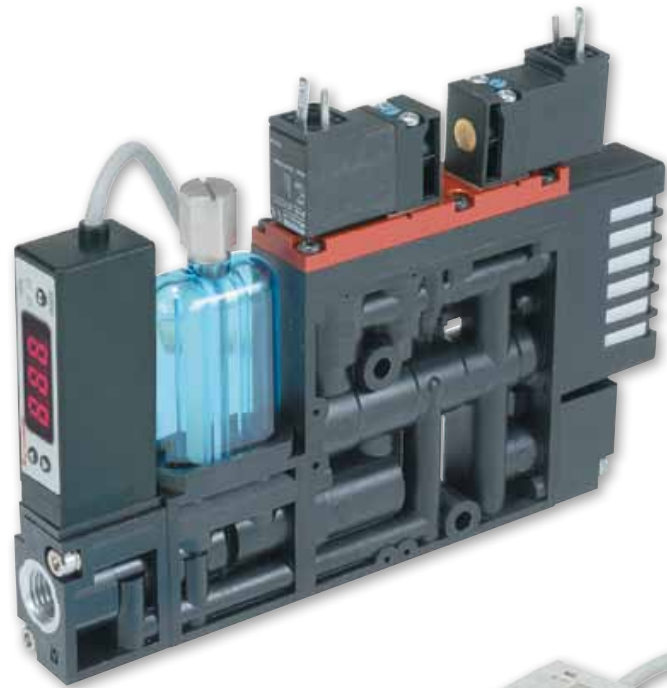

Vacuum Products

Cups, Generators, Sensors & Accessories

Catalogue PDE2654TCUK February 2012



ENGINEERING YOUR SUCCESS .

PDE2654TCUK

Warning, Offer of Sale

WARNING

FAILURE OR IMPROPER SELECTION OR IMPROPER USE OF THE PRODUCTS AND/OR SYSTEMS DESCRIBED HEREIN OR RELATED ITEMS CAN CAUSE DEATH, PERSONAL INJURY AND PROPERTY DAMAGE.

This document and other information from Parker Hannifin Corporation, its subsidiaries and authorized distributors provide product and/or system options for further investigation by users having technical expertise. It is important that you analyze all aspects of your application including consequences of any failure, and review the information concerning the product or system in the current product catalog. Due to the variety of operating conditions and applications for these products or systems, the user, through its own analysis and testing, is solely responsible for making the final selection of the products and systems and assuring that all performance, safety and warning requirements of the application are met.



The products described herein, including without limitation, product features, specifications, designs, availability and pricing, are subject to change by Parker Hannifin Corporation and its subsidiaries at any time without notice.

Offer of Sale

The items described in this document are hereby offered for sale by Parker Hannifin Corporation, its subsidiaries or its authorized distributors. This offer and its acceptance are governed by the provisions stated on the separate page of this document entitled "Offer of Sale".

© Copyright 2010 Parker Hannifin Corporation. All Rights Reserved

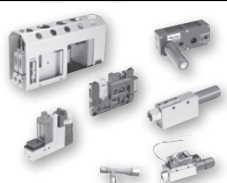

<p>Vacuum Cups</p>	<p>www.parker.com/pneu/vaccup</p>		<p>A Vacuum Cups</p>
<p>Vacuum Generators</p>	<p>www.parker.com/pneu/vacgen</p>		<p>B Generators</p>
<p>Pressure Sensors</p>	<p>www.parker.com/pneu/sensors</p>		<p>C Sensors</p>
<p>Safety Guide, Offer of Sale</p>			<p>D Vacuum Accessories</p>

- Think systems – create technical solutions!

A

For paper handling...

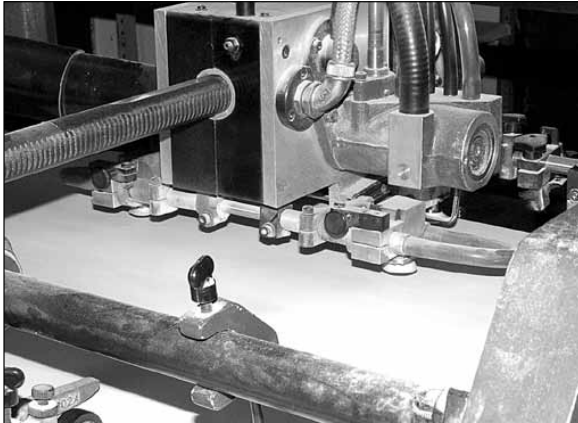

For robotic handling...

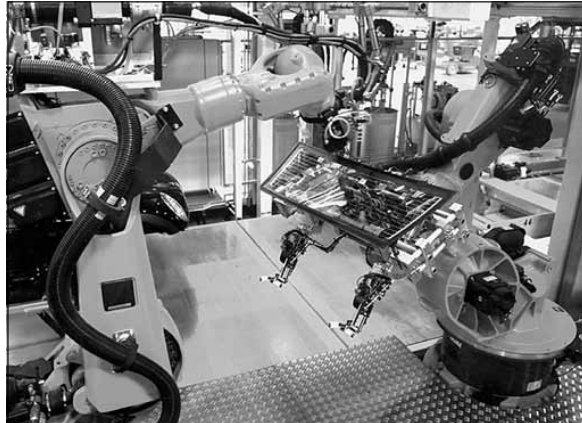
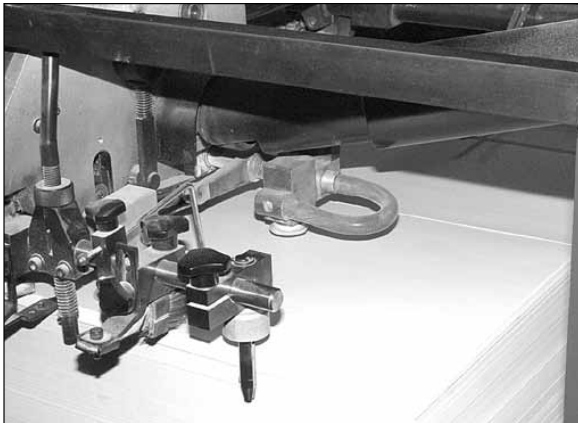
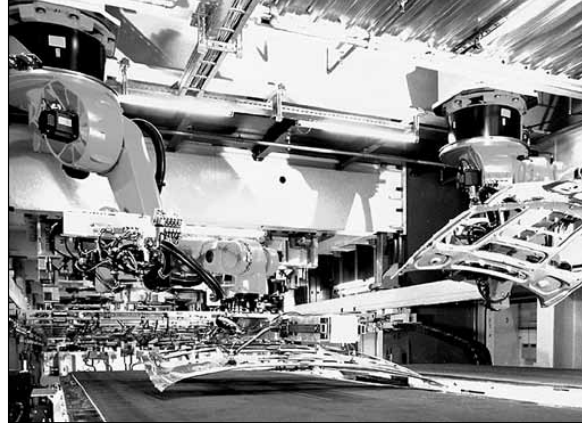

Vacuum Cups







A

Section A

www.parker.com/pneu/vaccup



A

Technical Information	Lifting Forces, Cup Diameters, Material Specifications	A3 - A5
PFG Flat 	Precision molded single lip flat cup for smooth or slightly curved surfaces. Low profile design makes flat pads ideal for fast response. Cup Sizes: 5mm to 200mm	A6 - A19
PBG Bellows 	Versatile bellows cup design provides a flexible sealing lip for products with irregular, smooth, curved surfaces, and flexible products. Cup Sizes: 10mm to 150mm	A20 - A32
PAG Foil, Paper, Film 	These cups have an ultra thin edge that creates the vacuum seal by conforming to the shape of the product. The complete foot pattern to the center of the cup prevents the vacuum from deforming or "puckering" thin, flexible products.	A33 - A41
P5V-CFS Flat 	Precision molded double lip flat cup for slightly curved surfaces. Double lip for additional security. If outside lip bends and loses its seal, the inner lip remains sealed. Outer ribs prevent the cup lip from being cut. Cup Sizes: 50mm to 300mm	A42
PJG Short Bellows 	Versatile bellows cup design provides a flexible sealing lip for products with irregular, smooth, curved surfaces, and slightly flexible products. Shorter stroke provides fast response. Cup Sizes: 6mm to 80mm	A43 - A56
PCG Multiple Bellows 	Versatile bellows cup design provides a flexible sealing lip for products with irregular, smooth, or curved surfaces. 2-1/2 bellows design minimizes contact pressure applied to products. Cup Sizes: 5mm to 90mm	A57 - A67
PUGB Flat Swivel 	30° swivel single lip flat cup for smooth surfaces, slightly curved surfaces, and flexible products. Rigid stem or level compensator provides good stability for horizontal lift. Cup Sizes: 60mm to 100mm	A68 - A72
Cup Screws	Cup screws.	A73
Cup Fitting Assemblies	Cup / Fitting Cross Reference.	A73 - A77



Specifications

Cup material should be considered for temperature resistance, chemical resistance, oil resistance, abrasion resistance, markless properties and electrical properties.



	NBR	NBRE	CR	SI	SIE	U
Suction cup material	Nitrile	Nitrile ESD*	Chloroprene	Silicon	Silicon ESD*	Urethane
Operating temperature (°C)	-20° to +120°	-30° to +120°	-30° to +140°	-60° to +250°	-60° to +250°	-30° to +120°
Color	Black	Black / Blue Dot	Green	White	Black / Red Dot	Blue
Hardness, shore A (°Sh)	55 ±5	70 ±5	55 ±5	55 ±5	55 ±5	55 ±5
Electrical resistance (Ωm)	—	800 to 1000	—	—	800 to 1000	—
Wear resistance	•••••	•••••	•••••	••	••	•••••
Tear strength	••••	••••	•••••	•	•	•••••
Aging resistance	••••	••••	•••••	••••••	••••••	•••••
Ozone resistance	••••	••••	•••••	••••••	••••••	•••••
Gasoline resistance	••••••	••••••	•••••	••••	••••	•••••
Oil resistance	••••••	••••••	•••••	••••••	••••••	•••••
Acid resistance	•••	•••	•••••	•••	•••	•
Alkali resistance	••••	••••	•••••	•••	•••	•
Chemical resistance	•••	•••	••••	••	••	•••••
Mechanical resistance	••••	••••	••••	••••	••••	•••••

•••••• = excellent; ••••• = very good; ••••• = good; •••• = medium; •• = poor; • = not recommended

* ESD: Electric Static Dissipative Material

A

Selecting the proper vacuum cup

⚠ CAUTION:

Selecting the type of vacuum cup, material, and size suitable for an application is important to the overall vacuum system. Calculating the forces involved for each application is recommended to determine the vacuum cup size. It should be noted that these calculations are basic theoretical guidelines and each application must be tested for actual results. With all vacuum applications, certain practical assumptions concerning cup materials, environmental conditions, and product characteristics to name a few, may not be consistent with the performance. Again, the user should determine the efficiency, performance, and safety factor of the cup selection.

Calculating pad diameter and forces

Mass

The term mass is a quantity of matter and its ability to resist motion when acted on by an external force. The magnitude of an object is represented as a certain number of kilograms (kg) and is symbolized as "m". The easiest way to determine the mass of an object is to measure the weight with a scale within the earth's gravitational field ($a_g = 9.81 \text{ m/sec}^2$). Likewise, outside of any gravitational field, a mass could potentially be weightless.

Forces

For vacuum applications, force is a vector quantity in a defined direction either horizontal or vertical. The standard international unit of force is measured in Newtons (N) which is the equivalent of (kgm/sec^2). The force can be calculated by measuring the effect of a change in acceleration on a mass.

Newtons Law: $F(N) = \text{mass}(kg) \times a_g(\text{m/sec}^2)$

Consider an object with a mass of 10kg. The gravitational force on this object would be:

$$F(N) = 10\text{kg} \times 9.81\text{m/sec}^2 = 98.1 \text{ N}$$

Acceleration

Acceleration is the change in velocity of a moving object. Acceleration is a vector, a directional quantity expressed in units of meters per second squared (m/sec^2) and symbolized as "a". To explain the magnitude of acceleration consider an object with a change in velocity of 2 meters per second (m/sec) over a 4 second time frame. The acceleration can be calculated with:

$$a = \frac{\Delta \text{ velocity}}{\text{time}} \quad a = \frac{6\text{m/sec}}{2 \text{ sec}} \quad a = 3\text{m/sec}^2$$

This is considered an average acceleration.

Coefficient of friction

Certain values for coefficient of friction should be taken into consideration when calculating the combined forces in motion. Actual values between suction cups and surfaces are difficult to determine. Therefore, coefficient of friction values from published charts, should be used as a reference to adjust the safety factors accordingly.

Lifting forces

When calculating lifting forces, safety factors of 2 for horizontal lifts and 4 for vertical lifts are minimum values. Applications with irregular shapes, difficult surfaces, and backward motions will require increased safety factors.

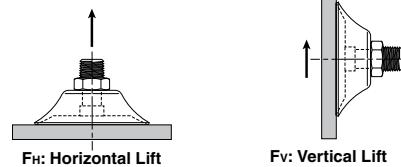

Horizontal lifting force

Apply Newtons Law to calculate the force on a 10kg mass with a change in acceleration of 3m/sec^2 and a safety factor of 2.

$$FH(N) = \text{mass}(kg) \times (a_g + a) \times SH$$

$$FH(N) = 10\text{kg} \times (9.81\text{m/sec}^2 + 3\text{m/sec}^2) \times 2$$

$$FH = 256.2 \text{ N}$$

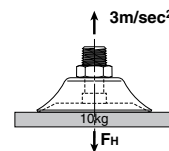

Vertical lifting force

Apply Newtons Law to calculate the force on a 10kg mass with a dry surface, a change in acceleration of 3m/sec^2 and a safety factor of 4.

$$FV(N) = \text{mass}(kg) \times (a_g + a) \times Sv$$

$$FV(N) = 10\text{kg} \times (9.81\text{m/sec}^2 + 3\text{m/sec}^2) \times 4$$

$$FV = 512.4 \text{ N}$$

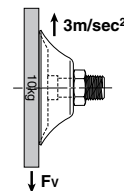

Combined vertical lift and horizontal motion

Calculate the force on a 10kg mass with a dry surface, a change in acceleration of 3m/sec^2 , and a change in travel acceleration of 2m/sec^2 .

$$FM(N) = \sqrt{FV^2 + FH^2}$$

$$FM(N) = \sqrt{[(10\text{kg} \times 2\text{m/sec}^2) \times 4]^2 + [10\text{kg} \times (9.81\text{m/sec}^2 + 3\text{m/sec}^2) \times 2]^2}$$

$$FM(N) = \sqrt{(80\text{kgm/sec}^2)^2 + [256\text{kgm/sec}^2]^2}$$

$$FM(N) = \sqrt{6400\text{kgm/sec}^2 + 65,536\text{kgm/sec}^2}$$

$$FM = 268.2 \text{ N}$$

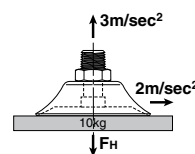

Analyze the forces

Using the previous examples, consider an application where 4 cups have been selected to transfer the product.

Take the Horizontal Lifting Force (FH) of 256.2 N and divide by the number of cups (4) to obtain the individual force for each cup.

$$\frac{256.2 \text{ (N)}}{4} = 64.05 \text{ N / Cup}$$

Referring to the chart below, at 60% vacuum, select a force greater than 64.05 N. The appropriate selection is a 40mm diameter cup which has a theoretical lifting force of 76.9 N.

The same calculation can be applied to the Vertical Lifting Force and the Forces in Motion examples to determine the cup diameter.

To convert Pounds (lbf) to Newton (N), multiply lbf x 4.4.

Theoretical lifting force per cup lbf (N)

Cup		Vacuum level								
Diameter mm	Area cm ²	3 inHg	6 inHg	9 inHg	12 inHg	15 inHg	18 inHg	21 inHg	24 inHg	27 inHg
		-1.5 PSIG	-3 PSIG	-4.5 PSIG	-6 PSIG	-7.5 PSIG	-9 PSIG	-10.5 PSIG	-12 PSIG	-13.5 PSIG
		10.2 kPa	20.3 kPa	30.5 kPa	40.6 kPa	50.8 kPa	61 kPa	71.1 kPa	81.3 kPa	91.4 kPa
		10%	20%	30%	40%	50%	60%	70%	80%	90%
1.5	0.01	0.004 (0.02)	0.008 (0.04)	0.008 (0.04)	0.014 (0.06)	0.018 (0.08)	0.022 (0.10)	0.026 (0.12)	0.032 (0.14)	0.032 (0.14)
2	0.03	0.007 (0.03)	0.013 (0.06)	0.022 (0.10)	0.029 (0.13)	0.036 (0.16)	0.043 (0.19)	0.049 (0.22)	0.056 (0.25)	0.063 (0.28)
3.5	0.10	0.022 (0.10)	0.045 (0.20)	0.065 (0.29)	0.088 (0.39)	0.110 (0.49)	0.133 (0.59)	0.155 (0.69)	0.175 (0.78)	0.198 (0.88)
5	0.20	0.045 (0.20)	0.090 (0.40)	0.135 (0.60)	0.180 (0.80)	0.225 (1.00)	0.270 (1.20)	0.315 (1.40)	0.360 (1.60)	0.405 (1.80)
6	0.28	0.065 (0.29)	0.130 (0.58)	0.196 (0.87)	0.270 (1.20)	0.315 (1.40)	0.382 (1.70)	0.450 (2.00)	0.517 (2.30)	0.585 (2.60)
7	0.39	0.088 (0.39)	0.175 (0.78)	0.265 (1.18)	0.360 (1.60)	0.450 (2.00)	0.540 (2.40)	0.607 (2.70)	0.697 (3.10)	0.787 (3.50)
8	0.50	0.117 (0.52)	0.229 (1.02)	0.346 (1.54)	0.450 (2.00)	0.585 (2.60)	0.697 (3.10)	0.809 (3.60)	0.922 (4.10)	1.034 (4.60)
10	0.79	0.180 (0.80)	0.360 (1.60)	0.540 (2.40)	0.719 (3.20)	0.899 (4.00)	1.079 (4.80)	1.259 (5.60)	1.439 (6.40)	1.619 (7.20)
15	1.77	0.404 (1.80)	0.809 (3.60)	1.216 (5.41)	1.619 (7.20)	2.023 (9.00)	2.428 (10.8)	2.833 (12.6)	3.237 (14.4)	3.642 (16.2)
18	2.55	0.585 (2.60)	1.169 (5.20)	1.751 (7.79)	2.338 (10.4)	2.923 (13.0)	3.507 (15.6)	4.069 (18.1)	4.676 (20.8)	5.238 (23.3)
20	3.14	0.719 (3.20)	1.439 (6.40)	2.158 (9.60)	2.878 (12.8)	3.597 (16.0)	4.316 (19.2)	5.036 (22.4)	5.755 (25.6)	6.474 (28.8)
25	4.91	1.124 (5.00)	2.248 (10.0)	3.372 (15.0)	4.496 (20.0)	5.620 (25.0)	6.744 (30.0)	7.868 (35.0)	8.992 (40.0)	10.116 (45.0)
30	7.07	1.619 (7.20)	3.237 (14.4)	4.856 (21.6)	6.474 (28.8)	8.093 (36.0)	9.712 (43.2)	11.330 (50.4)	12.949 (57.6)	14.568 (64.8)
35	9.62	2.203 (9.80)	4.406 (19.6)	6.609 (29.4)	8.813 (39.2)	11.016 (49.0)	13.241 (58.9)	15.422 (68.6)	17.648 (78.5)	19.828 (88.2)
40	12.6	2.900 (12.9)	5.755 (25.6)	8.655 (38.5)	11.510 (51.2)	14.388 (64.0)	17.288 (76.9)	20.143 (89.6)	23.155 (103)	25.853 (115)
50	19.6	4.519 (20.1)	8.992 (40.0)	13.511 (60.1)	17.985 (80.0)	22.481 (100)	26.977 (120)	31.473 (140)	35.969 (160)	40.466 (180)
60	28.3	6.497 (28.9)	12.949 (57.6)	19.446 (86.5)	25.853 (115)	32.372 (144)	38.892 (173)	45.411 (202)	51.931 (231)	58.226 (259)
75	44.2	10.161 (45.2)	20.233 (90.0)	30.349 (135)	40.466 (180)	50.582 (225)	60.698 (270)	70.815 (315)	80.931 (360)	91.048 (405)
80	50.3	11.555 (51.4)	22.931 (102)	34.621 (154)	46.086 (205)	57.551 (256)	69.241 (308)	80.706 (359)	92.172 (410)	103.637 (461)
90	63.6	14.635 (65.1)	29.225 (130)	43.838 (195)	58.226 (259)	72.838 (324)	87.451 (389)	102.063 (454)	116.676 (519)	131.064 (583)
95	70.9	16.299 (72.5)	32.372 (144)	48.784 (217)	64.970 (289)	81.156 (361)	97.567 (434)	113.753 (506)	129.940 (578)	146.126 (650)
110	95.0	21.851 (97.2)	43.613 (194)	65.419 (291)	87.001 (387)	108.808 (484)	130.614 (581)	152.421 (678)	174.227 (775)	195.809 (871)
120	113.1	26.078 (116)	51.706 (230)	77.784 (346)	103.637 (461)	129.490 (576)	155.568 (692)	181.421 (807)	207.274 (922)	233.127 (1037)
150	176.7	40.690 (181)	80.931 (360)	121.622 (541)	161.862 (720)	202.328 (900)	243.019 (1081)	283.259 (1260)	323.950 (1441)	364.191 (1620)
200	314.2	72.164 (321)	143.878 (640)	216.041 (961)	287.531 (1279)	359.919 (1601)	432.083 (1922)	503.797 (2241)	575.961 (2562)	647.449 (2880)

Calculate the diameter of the cup

Calculate the cup diameter for horizontal lift at 60% of full vacuum using the information from the previous page.

$$D = 35.7 \sqrt{\frac{m(a_g + a) \times S}{P_v \times n}}$$

D (mm) = Diameter of Cup
m (kg) = Mass
a_g = 9.81m/sec²

$$D = 35.7 \sqrt{\frac{10(9.81 + 3) \times 2}{61 \times 4}}$$

a = Motion Acceleration
S = Safety Factor
P_v (kPa) = Operating Vacuum Pressure
n = number of Cups

$$D = 36.58 \text{ mm}$$

Referring to the chart below, at 60% vacuum, select a cup diameter equal to or greater than 37mm. The appropriate selection is a 40mm diameter cup which has a theoretical lifting force of 76.9 N.



A

Exceptional for any smooth flat or surface that will benefit from stability and fast response of the cup design. This is a multi-versatile and multi-industry cup. Typical applications could be chip mounting, electrical components, semiconductor chips, glass, injection mold, sheet metal, press transfer, fixtures, woodworking.

Features

- Precision molded single lip flat cup for smooth or slightly curved surfaces.
- Universal flat design for most smooth surface applications
- Stable vertical / horizontal lift
- Strong low profile design for fast response needed for short cycles
- 5mm to 200mm diameters
- Bottom cleats on 60 to 200mm diameters



Styles

- PFTM series male thread connector
- PFTF series female thread connector
- PFTK series barbed bulkhead
- PFYK series 90° barbed adapter
- PFTYS series bulkhead level compensator

Specifications

Cup material	Nitrile	Nitrile ESD*	Silicon	Silicon ESD*	Urethane
Material code	NBR	NBRE	SI	SIE	U
Operating temperature (°C)	-20° to +120°	-30° to +120°	-60° to +250°	-60° to +250°	-30° to +120°
Color	Black	Black / Blue Dot	White	Black / Red Dot	Blue
Hardness, shore A (°Sh)	55 ±5	70 ±5	55 ±5	55 ±5	55 ±5
Electrical resistance (Ωm)	—	800 to 1000	—	800 to 1000	—

* ESD: Electric Static Dissipative Material

How to order

Cups Assemblies and replacement cups are specified by Cup Diameter and Material. Standard Nitrile and silicon are listed on the following pages. To specify an alternative material, replace the cup material with alternative cup material code.

Example: To specify a cup assembly with Urethane (U), replace (NBR) with (U) in the part number. PFTM-20B-NBR-G1 becomes PFTM-20B-U-G1. Inquire with factory for availability.

Application guide

Flat - Smooth surface

Flat surface, thin section	Flat surface, any section	Slightly bowed surface, thin section	Slightly bowed surface, any section	Metal sheet handling	Corrugated sheet handling	High lifting force	Vertical lift

Ø 120/200 only

PFTM Series Male Thread Connector

Simple male connection for low profile positions secured to a plate or bracket. BSPP, NPT metric threads.
 Fitting material: aluminum.

Installation

Note:
 When installing cup assemblies, use a sealant material to secure the assembly and prevent vacuum leakage.

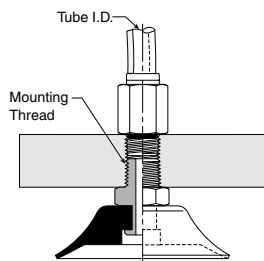

A

Cup diameter (mm)	Vacuum port	Complete assembly Nitrile (NBR)	Replacement cup Nitrile (NBR)	Complete assembly Silicon (SI)	Replacement cup Silicon (SI)	Replacement cup fitting
5	M5	PFTM-5A-NBR-M5	PFG-5A-NBR	PFTM-5A-SI-M5	PFG-5A-SI	FTM-5A-M5
5	1/8 BSPP	PFTM-5A-NBR-G1	PFG-5A-NBR	PFTM-5A-SI-G1	PFG-5A-SI	FTM-5A-G1
6	M5	PFTM-6A-NBR-M5	PFG-6A-NBR	PFTM-6A-SI-M5	PFG-6A-SI	FTM-5A-M5
6	1/8 BSPP	PFTM-6A-NBR-G1	PFG-6A-NBR	PFTM-6A-SI-G1	PFG-6A-SI	FTM-5A-G1
8	M5	PFTM-8A-NBR-M5	PFG-8A-NBR	PFTM-8A-SI-M5	PFG-8A-SI	FTM-5A-M5
8	1/8 BSPP	PFTM-8A-NBR-G1	PFG-8A-NBR	PFTM-8A-SI-G1	PFG-8A-SI	FTM-5A-G1
10	M5	PFTM-10A-NBR-M5	PFG-10A-NBR	PFTM-10A-SI-M5	PFG-10A-SI	FTM-5A-M5
10	1/8 BSPP	PFTM-10A-NBR-G1	PFG-10A-NBR	PFTM-10A-SI-G1	PFG-10A-SI	FTM-5A-G1
15	M5	PFTM-15A-NBR-M5	PFG-15A-NBR	PFTM-15A-SI-M5	PFG-15A-SI	FTM-5A-M5
15	1/8 BSPP	PFTM-15A-NBR-G1	PFG-15A-NBR	PFTM-15A-SI-G1	PFG-15A-SI	FTM-5A-G1
20	1/8 BSPP	PFTM-20B-NBR-G1	PFG-20B-NBR	PFTM-20B-SI-G1	PFG-20B-SI	FTM-20B-G1
20	1/4 BSPP	PFTM-20B-NBR-G2	PFG-20B-NBR	PFTM-20B-SI-G2	PFG-20B-SI	FTM-20B-G2
20	M10	PFTM-20B-NBR-M10	PFG-20B-NBR	PFTM-20B-SI-M10	PFG-20B-SI	FTM-20B-M10
20	1/8 NPT	PFTM-20B-NBR-N1	PFG-20B-NBR	PFTM-20B-SI-N1	PFG-20B-SI	FTM-20B-N1
30	1/8 BSPP	PFTM-30-NBR-G1	PFG-30-NBR	PFTM-30-SI-G1	PFG-30-SI	FTM-20B-G1
30	1/4 BSPP	PFTM-30-NBR-G2	PFG-30-NBR	PFTM-30-SI-G2	PFG-30-SI	FTM-20B-G2
30	M10	PFTM-30-NBR-M10	PFG-30-NBR	PFTM-30-SI-M10	PFG-30-SI	FTM-20B-M10
30	1/8 NPT	PFTM-30-NBR-N1	PFG-30-NBR	PFTM-30-SI-N1	PFG-30-SI	FTM-20B-N1
40	1/8 BSPP	PFTM-40-NBR-G1	PFG-40-NBR	PFTM-40-SI-G1	PFG-40-SI	FTM-20B-G1
40	1/4 BSPP	PFTM-40-NBR-G2	PFG-40-NBR	PFTM-40-SI-G2	PFG-40-SI	FTM-20B-G2
40	M10	PFTM-40-NBR-M10	PFG-40-NBR	PFTM-40-SI-M10	PFG-40-SI	FTM-20B-M10
40	1/8 NPT	PFTM-40-NBR-N1	PFG-40-NBR	PFTM-40-SI-N1	PFG-40-SI	FTM-20B-N1
50	1/8 BSPP	PFTM-50-NBR-G1	PFG-50-NBR	PFTM-50-SI-G1	PFG-50-SI	FTM-50-G1
50	1/4 BSPP	PFTM-50-NBR-G2	PFG-50-NBR	PFTM-50-SI-G2	PFG-50-SI	FTM-50-G2
50	1/8 NPT	PFTM-50-NBR-N1	PFG-50-NBR	PFTM-50-SI-N1	PFG-50-SI	FTM-50-N1
60	1/4 BSPP	PFTM-60-NBR-G2	PFG-60-NBR	PFTM-60-SI-G2	PFG-60-SI	FTM-60-G2
60	M10	PFTM-60-NBR-M10	PFG-60-NBR	PFTM-60-SI-M10	PFG-60-SI	FTM-60-M10
60	1/4 NPT	PFTM-60-NBR-N2	PFG-60-NBR	PFTM-60-SI-N2	PFG-60-SI	FTM-60-N2
80	1/4 BSPP	PFTM-80-NBR-G2	PFG-80-NBR	PFTM-80-SI-G2	PFG-80-SI	FTM-60-G2
80	M10	PFTM-80-NBR-M10	PFG-80-NBR	PFTM-80-SI-M10	PFG-80-SI	FTM-60-M10
80	1/4 NPT	PFTM-80-NBR-N2	PFG-80-NBR	PFTM-80-SI-N2	PFG-80-SI	FTM-60-N2
95	1/4 BSPP	PFTM-95-NBR-G2	PFG-95-NBR	PFTM-95-SI-G2	PFG-95-SI	FTM-60-G2
95	M10	PFTM-95-NBR-M10	PFG-95-NBR	PFTM-95-SI-M10	PFG-95-SI	FTM-60-M10
95	1/4 NPT	PFTM-95-NBR-N2	PFG-95-NBR	PFTM-95-SI-N2	PFG-95-SI	FTM-60-N2

A

PFTF Series Female Thread Connector

Simple female connection for low profile positions secured to a plate or bracket. BSPP, NPT threads.

Fitting material: aluminum.

Installation

Note:

When installing cup assemblies, use a sealant material to secure the assembly and prevent vacuum leakage.

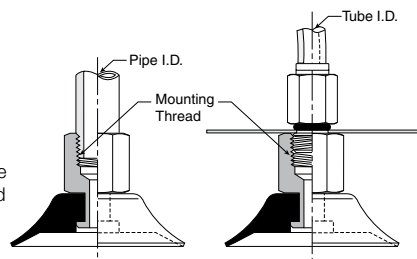

Cup diameter (mm)	Vacuum port	Complete assembly Nitrile (NBR)	Replacement cup Nitrile (NBR)	Complete assembly Silicon (SI)	Replacement cup Silicon (SI)	Replacement cup fitting
5	M5	PFTF-5A-NBR-M5	PFG-5A-NBR	PFTF-5A-SI-M5	PFG-5A-SI	FTF-5A-M5
5	1/8 BSPP	PFTF-5A-NBR-G1	PFG-5A-NBR	PFTF-5A-SI-G1	PFG-5A-SI	FTF-5A-G1
6	M5	PFTF-6A-NBR-M5	PFG-6A-NBR	PFTF-6A-SI-M5	PFG-6A-SI	FTF-5A-M5
6	1/8 BSPP	PFTF-6A-NBR-G1	PFG-6A-NBR	PFTF-6A-SI-G1	PFG-6A-SI	FTF-5A-G1
8	M5	PFTF-8A-NBR-M5	PFG-8A-NBR	PFTF-8A-SI-M5	PFG-8A-SI	FTF-5A-M5
8	1/8 BSPP	PFTF-8A-NBR-G1	PFG-8A-NBR	PFTF-8A-SI-G1	PFG-8A-SI	FTF-5A-G1
10	1/8 BSPP	PFTF-10A-NBR-G1	PFG-10A-NBR	PFTF-10A-SI-G1	PFG-10A-SI	FTF-5A-G1
10	M5	PFTF-10A-NBR-M5	PFG-10A-NBR	PFTF-10A-SI-M5	PFG-10A-SI	FTF-5A-M5
15	1/8 BSPP	PFTF-15A-NBR-G1	PFG-15A-NBR	PFTF-15A-SI-G1	PFG-15A-SI	FTF-5A-G1
15	M5	PFTF-15A-NBR-M5	PFG-15A-NBR	PFTF-15A-SI-M5	PFG-15A-SI	FTF-5A-M5
20	1/8 BSPP	PFTF-20B-NBR-G1	PFG-20B-NBR	PFTF-20B-SI-G1	PFG-20B-SI	FTF-20B-G1
30	1/8 BSPP	PFTF-30-NBR-G1	PFG-30-NBR	PFTF-30-SI-G1	PFG-30-SI	FTF-20B-G1
30	1/4 BSPP	PFTF-30-NBR-G2	PFG-30-NBR	PFTF-30-SI-G2	PFG-30-SI	FTF-20B-G2
40	1/8 BSPP	PFTF-40-NBR-G1	PFG-40-NBR	PFTF-40-SI-G1	PFG-40-SI	FTF-20B-G1
40	1/4 BSPP	PFTF-40-NBR-G2	PFG-40-NBR	PFTF-40-SI-G2	PFG-40-SI	FTF-20B-G2
50	1/8 BSPP	PFTF-50-NBR-G1	PFG-50-NBR	PFTF-50-SI-G1	PFG-50-SI	FTF-50-G1
50	1/4 BSPP	PFTF-50-NBR-G2	PFG-50-NBR	PFTF-50-SI-G2	PFG-50-SI	FTF-50-G2
60	1/4 BSPP	PFTF-60-NBR-G2	PFG-60-NBR	PFTF-60-SI-G2	PFG-60-SI	FTF-60-G2
60	1/4 NPT	PFTF-60-NBR-N2	PFG-60-NBR	PFTF-60-SI-N2	PFG-60-SI	FTF-60-N2
80	1/4 BSPP	PFTF-80-NBR-G2	PFG-80-NBR	PFTF-80-SI-G2	PFG-80-SI	FTF-60-G2
80	1/4 NPT	PFTF-80-NBR-N2	PFG-80-NBR	PFTF-80-SI-N2	PFG-80-SI	FTF-60-N2
95	1/4 NPT	PFTF-95-NBR-N2	PFG-95-NBR	PFTF-95-SI-N2	PFG-95-SI	FTF-60-N2
95	1/4 BSPP	PFTF-95-NBR-G2	PFG-95-NBR	PFTF-95-SI-G2	PFG-95-SI	FTF-60-G2
120	1/2 BSPP	PFTF-120-NBR-G4	PFG-120-NBR	PFTF-120-SI-G4	PFG-120-SI	FTF-120-G4
120	1/2 NPT	PFTF-120-NBR-N4	PFG-120-NBR	PFTF-120-SI-N4	PFG-120-SI	FTF-120-N4
150	1/2 NPT	PFTF-150-NBR-G4	PFG-150-NBR	PFTF-150-SI-G4	PFG-150-SI	FTF-120-G4
150	1/2 NPT	PFTF-150-NBR-N4	PFG-150-NBR	PFTF-150-SI-N4	PFG-150-SI	FTF-120-N4
200	1/2 BSPP	PFTF-200-NBR-G4	PFG-200-NBR	PFTF-200-SI-G4	PFG-200-SI	FTF-120-G4
200	1/2 NPT	PFTF-200-NBR-N4	PFG-200-NBR	PFTF-200-SI-N4	PFG-200-SI	FTF-120-N4

PFTK Series Barbed Bulkhead

Top stem connectors secured with jam nuts and allow tubing connections at the top side. Fitting material: nickel plated brass.

Installation

Note:
 When installing cup assemblies, use a sealant material to secure the assembly and prevent vacuum leakage.

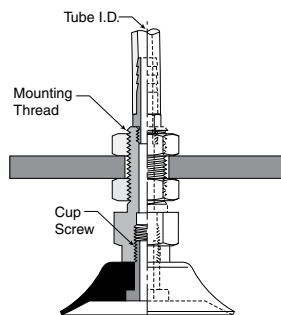

A

Cup diameter (mm)	Vacuum port	Complete assembly Nitrile (NBR)	Replacement cup Nitrile (NBR)	Complete assembly Silicon (SI)	Replacement cup Silicon (SI)	Replacement cup fitting
5	Barb	PFTK-5A-NBR	PFG-5A-NBR	PFTK-5A-SI	PFG-5A-SI	FTK-5A
6	Barb	PFTK-6A-NBR	PFG-6A-NBR	PFTK-6A-SI	PFG-6A-SI	FTK-5A
8	Barb	PFTK-8A-NBR	PFG-8A-NBR	PFTK-8A-SI	PFG-8A-SI	FTK-5A
10	Barb	PFTK-10A-NBR	PFG-10A-NBR	PFTK-10A-SI	PFG-10A-SI	FTK-5A
15	Barb	PFTK-15-NBR	PFG-15-NBR	PFTK-15-SI	PFG-15-SI	FTK-15
20	Barb	PFTK-20-NBR	PFG-20-NBR	PFTK-20-SI	PFG-20-SI	FTK-20
30	Barb	PFTK-30-NBR	PFG-30-NBR	PFTK-30-SI	PFG-30-SI	FTK-25
40	Barb	PFTK-40-NBR	PFG-40-NBR	PFTK-40-SI	PFG-40-SI	FTK-25
50	Barb	PFTK-50-NBR	PFG-50-NBR	PFTK-50-SI	PFG-50-SI	FTK-50
60	1/8 BSPP	PFTK-60-NBR-G1	PFG-60-NBR	PFTK-60-SI-G1	PFG-60-SI	FTK-60-G1
60	1/8 NPT	PFTK-60-NBR-N1	PFG-60-NBR	PFTK-60-SI-N1	PFG-60-SI	FTK-60-N1
80	1/8 BSPP	PFTK-80-NBR-G1	PFG-80-NBR	PFTK-80-SI-G1	PFG-80-SI	FTK-60-G1
80	1/8 NPT	PFTK-80-NBR-N1	PFG-80-NBR	PFTK-80-SI-N1	PFG-80-SI	FTK-60-N1
95	1/8 BSPP	PFTK-95-NBR-G1	PFG-95-NBR	PFTK-95-SI-G1	PFG-95-SI	FTK-60-G1
95	1/8 NPT	PFTK-95-NBR-N1	PFG-95-NBR	PFTK-95-SI-N1	PFG-95-SI	FTK-60-N1

A

PFYK Series 90° Barbed Adapter

Side stem connectors allow you to secure the stem with a bolt thru a plate or "L" bracket to allow the tube connection from the side port. Fitting material: nickel plated brass.

Installation

Note:

When installing cup assemblies, use a sealant material to secure the assembly and prevent vacuum leakage.

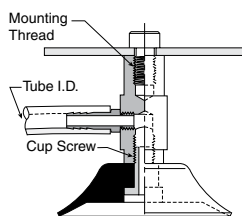

Cup diameter (mm)	Vacuum port	Complete assembly Nitrile (NBR)	Replacement cup Nitrile (NBR)	Complete assembly Silicon (SI)	Replacement cup Silicon (SI)	Replacement cup fitting
5	Barb	PFYK-5A-NBR	PFG-5A-NBR	PFYK-5A-SI	PFG-5A-SI	FYK-5A
6	Barb	PFYK-6A-NBR	PFG-6A-NBR	PFYK-6A-SI	PFG-6A-SI	FYK-5A
8	Barb	PFYK-8A-NBR	PFG-8A-NBR	PFYK-8A-SI	PFG-8A-SI	FYK-5A
10	Barb	PFYK-10A-NBR	PFG-10A-NBR	PFYK-10A-SI	PFG-10A-SI	FYK-5A
15	Barb	PFYK-15-NBR	PFG-15-NBR	PFYK-15-SI	PFG-15-SI	FYK-15
20	Barb	PFYK-20-NBR	PFG-20-NBR	PFYK-20-SI	PFG-20-SI	FYK-20
30	Barb	PFYK-30-NBR	PFG-30-NBR	PFYK-30-SI	PFG-30-SI	FYK-25
40	Barb	PFYK-40-NBR	PFG-40-NBR	PFYK-40-SI	PFG-40-SI	FYK-25
50	Barb	PFYK-50-NBR	PFG-50-NBR	PFYK-50-SI	PFG-50-SI	FYK-50
60	1/8 BSPP	PFYK-60-NBR-G1	PFG-60-NBR	PFYK-60-SI-G1	PFG-60-SI	FYK-60-G1
60	1/8 NPT	PFYK-60-NBR-N1	PFG-60-NBR	PFYK-60-SI-N1	PFG-60-SI	FYK-60-N1
80	1/8 BSPP	PFYK-80-NBR-G1	PFG-80-NBR	PFYK-80-SI-G1	PFG-80-SI	FYK-60-G1
80	1/8 NPT	PFYK-80-NBR-N1	PFG-80-NBR	PFYK-80-SI-N1	PFG-80-SI	FYK-60-N1
95	1/8 BSPP	PFYK-95-NBR-G1	PFG-95-NBR	PFYK-95-SI-G1	PFG-95-SI	FYK-60-G1
95	1/8 NPT	PFYK-95-NBR-N1	PFG-95-NBR	PFYK-95-SI-N1	PFG-95-SI	FYK-60-N1
120	1/8 BSPP	PFYK-120-NBR-G1	PFG-120-NBR	PFYK-120-SI-G1	PFG-120-SI	FYK-120-G1
120	1/8 NPT	PFYK-120-NBR-N1	PFG-120-NBR	PFYK-120-SI-N1	PFG-120-SI	FYK-120-N1
150	1/8 BSPP	PFYK-150-NBR-G1	PFG-150-NBR	PFYK-150-SI-G1	PFG-150-SI	FYK-120-G1
150	1/8 NPT	PFYK-150-NBR-N1	PFG-150-NBR	PFYK-150-SI-N1	PFG-150-SI	FYK-120-N1
200	1/8 BSPP	PFYK-200-NBR-G1	PFG-200-NBR	PFYK-200-SI-G1	PFG-200-SI	FYK-120-G1
200	1/8 NPT	PFYK-200-NBR-N1	PFG-200-NBR	PFYK-200-SI-N1	PFG-200-SI	FYK-120-N1

PFTYS Series Bulkhead Level Compensator

303 stainless steel construction secured with jam nuts. Spring biased compensators can absorb impacts of down-strokes and adjust for different levels of pick up points. 303 stainless corrosion resistant materials with drymet bushings increases the strength and life.

Installation

Note:

When installing cup assemblies, use a sealant material to secure the assembly and prevent vacuum leakage.

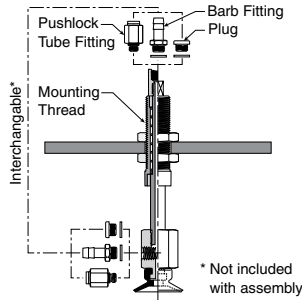

Cup dia. (mm)	Vacuum port	Stroke (mm)	Spring compression Force lbf (N)		Cup material Nitrile assembly (NBR)	Replacement cup Nitrile (NBR)	Cup material Silicon assembly (SI)	Replacement cup Silicon (SI)	Level Compensator P/N
			0%	100%					
5	M5	10	.14 (.61)	.26 (1.17)	PFTYS5A10NBRM5	PFG-5A-NBR	PFTYS5A10SIM5	PFG-5A-SI	FTYS-5A-10-M5
5	M5	15	.15 (.64)	.26 (1.17)	PFTYS5A15NBRM5	PFG-5A-NBR	PFTYS5A15SIM5	PFG-5A-SI	FTYS-5A-15-M5
6	M5	10	.14 (.61)	.26 (1.17)	PFTYS6A10NBRM5	PFG-6A-NBR	PFTYS6A10SIM5	PFG-6A-SI	FTYS-5A-10-M5
6	M5	15	.15 (.64)	.26 (1.17)	PFTYS6A15NBRM5	PFG-6A-NBR	PFTYS6A15SIM5	PFG-6A-SI	FTYS-5A-15-M5
8	M5	10	.14 (.61)	.26 (1.17)	PFTYS8A10NBRM5	PFG-8A-NBR	PFTYS8A10SIM5	PFG-8A-SI	FTYS-5A-10-M5
8	M5	15	.15 (.64)	.26 (1.17)	PFTYS8A15NBRM5	PFG-8A-NBR	PFTYS8A15SIM5	PFG-8A-SI	FTYS-5A-15-M5
10	M5	10	.11 (.49)	.13 (.59)	PFTYS10A10NBRM5	PFG-10A-NBR	PFTYS10A10SIM5	PFG-10A-SI	FTYS-5A-10-M5
10	M5	15	.11 (.49)	.13 (.59)	PFTYS10A15NBRM5	PFG-10A-NBR	PFTYS10A15SIM5	PFG-10A-SI	FTYS-5A-15-M5
15	M5	10	.11 (.49)	.13 (.59)	PFTYS15A10NBRM5	PFG-15A-NBR	PFTYS15A10SIM5	PFG-15A-SI	FTYS-5A-10-M5
15	M5	15	.11 (.49)	.13 (.59)	PFTYS15A15NBRM5	PFG-15A-NBR	PFTYS15A15SIM5	PFG-15A-SI	FTYS-5A-15-M5
20	M5	15	.56 (2.5)	.79 (3.4)	PFTYS20B15NBRM5	PFG-20B-NBR	PFTYS20B15SIM5	PFG-20B-SI	FTYS-20B-15-M5
20	M5	30	.56 (2.5)	1.2 (4.9)	PFTYS20B30NBRM5	PFG-20B-NBR	PFTYS20B30SIM5	PFG-20B-SI	FTYS-20B-30-M5
30	M5	15	.56 (2.5)	.79 (3.4)	PFTYS3015NBRM5	PFG-30-NBR	PFTYS3015SIM5	PFG-30-SI	FTYS-20B-15-M5
30	M5	30	.56 (2.5)	1.2 (4.9)	PFTYS3030NBRM5	PFG-30-NBR	PFTYS3030SIM5	PFG-30-SI	FTYS-20B-30-M5
40	M5	15	.56 (2.5)	.79 (3.4)	PFTYS4015NBRM5	PFG-40-NBR	PFTYS4015SIM5	PFG-40-SI	FTYS-20B-15-M5
40	M5	30	.56 (2.5)	1.2 (4.9)	PFTYS4030NBRM5	PFG-40-NBR	PFTYS4030SIM5	PFG-40-SI	FTYS-20B-30-M5
50	M5	15	.56 (2.5)	1.2 (4.9)	PFTYS5015NBRM5	PFG-50-NBR	PFTYS5015SIM5	PFG-50-SI	FTYS-50-15-M5
50	M5	30	.67 (2.9)	1.4 (5.9)	PFTYS5030NBRM5	PFG-50-NBR	PFTYS5030SIM5	PFG-50-SI	FTYS-50-30-M5
60	1/8 BSPP	30	1.6 (6.8)	3.6 (15.6)	PFTYS6030NBRG1	PFG-60-NBR	PFTYS6030SIG1	PFG-60-SI	FTYS-60-30-G1
60	1/8 BSPP	50	1.9 (8.3)	4.5 (19.6)	PFTYS6050NBRG1	PFG-60-NBR	PFTYS6050SIG1	PFG-60-SI	FTYS-60-50-G1
80	1/8 BSPP	30	1.6 (6.8)	3.6 (15.6)	PFTYS8030NBRG1	PFG-80-NBR	PFTYS8030SIG1	PFG-80-SI	FTYS-60-30-G1
80	1/8 BSPP	50	1.9 (8.3)	4.5 (19.6)	PFTYS8050NBRG1	PFG-80-NBR	PFTYS8050SIG1	PFG-80-SI	FTYS-60-50-G1
95	1/8 BSPP	30	1.6 (6.8)	3.6 (15.6)	PFTYS9530NBRG1	PFG-95-NBR	PFTYS9530SIG1	PFG-95-SI	FTYS-60-30-G1
95	1/8 BSPP	50	1.9 (8.3)	4.5 (19.6)	PFTYS9550NBRG1	PFG-95-NBR	PFTYS9550SIG1	PFG-95-SI	FTYS-60-50-G1
120	1/4 BSPP	20	3.6 (15.6)	6.8 (29)	PFTYS12020NBRG2	PFG-120-NBR	PFTYS12020SIG2	PFG-120-SI	FTYS-120-20-G2
120	1/4 BSPP	50	3.4 (14.7)	6.8 (29)	PFTYS12050NBRG2	PFG-120-NBR	PFTYS12050SIG2	PFG-120-SI	FTYS-120-50-G2
150	1/4 BSPP	20	3.6 (15.6)	6.8 (29)	PFTYS15020NBRG2	PFG-150-NBR	PFTYS15020SIG2	PFG-150-SI	FTYS-120-20-G2
150	1/4 BSPP	50	3.4 (14.7)	6.8 (29)	PFTYS15050NBRG2	PFG-150-NBR	PFTYS15050SIG2	PFG-150-SI	FTYS-120-50-G2
200	1/4 BSPP	20	3.6 (15.6)	6.8 (29)	PFTYS20020NBRG2	PFG-200-NBR	PFTYS20020SIG2	PFG-200-SI	FTYS-120-20-G2
200	1/4 BSPP	50	3.4 (14.7)	6.8 (29)	PFTYS20050NBRG2	PFG-200-NBR	PFTYS20050SIG2	PFG-200-SI	FTYS-120-50-G2

A

Applications

- Products with smooth surfaces
- Products with minimum flex
- Products that will not permanently deform

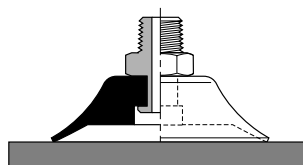

Main data for flat PFG cups

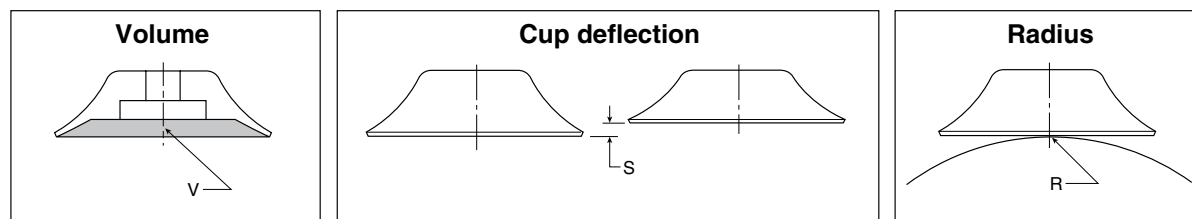

Model number	Cup diameter mm	Area cm ²	Volume (V) liters	Lifting force @60% (N)		Cup deflection (S) mm	Radius (R) mm
PFG-5A-*	5	0.20	0.000005	1.20	0.6	0.5	3.5
PFG-6A-*	6	0.28	0.000008	1.70	0.85	1.0	4.0
PFG-8A-*	8	0.50	0.00003	3.10	1.5	1.4	5.0
PFG-10A-*	10	0.79	0.00007	4.80	2.4	1.5	6.0
PFG-15-*	15	1.77	0.0004	10.8	5.4	1.9	6.0
PFG-15A-*	15	1.77	0.0004	10.8	5.4	1.9	6.0
PFG-20-*	20	3.14	0.0008	19.2	9.6	2.3	9.0
PFG-20B-*	20	3.14	0.0008	19.2	9.6	2.3	13.0
PFG-30-*	30	7.07	0.0018	43.2	21.6	2.0	26
PFG-40-*	40	12.60	0.004	76.9	38.5	3.5	37
PFG-50-*	50	19.60	0.007	120	60	4.0	41
PFG-60-*	60	28.30	0.0090	173	87	5.0	70
PFG-80-*	80	50.30	0.025	308	154	6.0	100
PFG-95-*	95	70.90	0.035	434	267	6.0	150
PFG-120-*	120	113.00	0.078	692	346	6.0	365
PFG-150-*	150	176.70	0.177	1081	541	9.0	380
PFG-200-*	200	314.20	0.425	1922	961	13.0	430

* Cup material

PFG Series Replacement Cup Dimensions

PFG-5A
PFG-15A

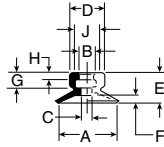

PFG-15 thru
PFG-40

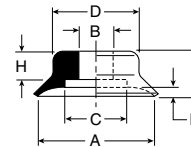

PFG-50

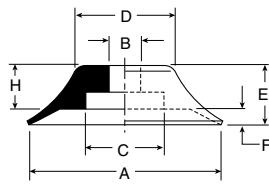

PFG-120 thru
PFG-200

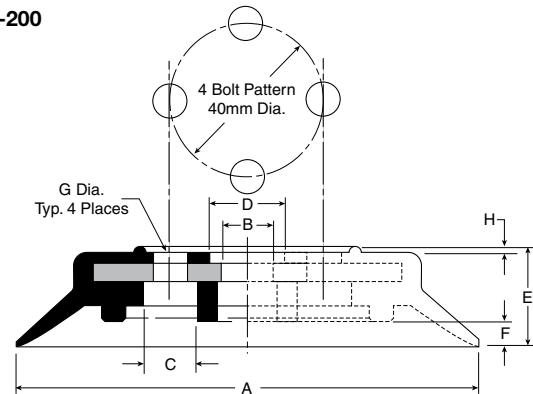

PFG-60 thru
PFG-95

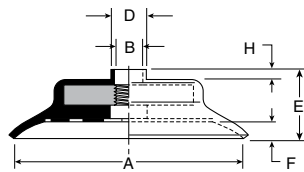

Dimensions (mm)

Model number	ØA	ØB	ØC	ØD	E	F	G	H	ØJ
PFG-5A*	5	4	1.4	7.5	6.5	.8	4	2	6
PFG-6A*	6	4	2	7.5	6.5	.8	4	2	6
PFG-8A*	8	4	2	8	7	1.2	4	2	6
PFG-10A*	10	4	2	8.5	7.5	1.5	4	2	6
PFG-15*	15	—	7.8	12	8	1.9	—	—	—
PFG-15A*	15	4	2	9	8	2	4	2	6
PFG-20*	20	4.6	11	15	10	2.3	—	4.5	—
PFG-20B*	20	6	11	15	12.5	2.3	—	7	—
PFG-30*	30	6	11	14	12	2	—	7	—
PFG-40*	40	6	11	24	14	4	—	7	—
PFG-50*	50	8	20	27	15	3.5	—	7	—
PFG-60*	60	M10x1.25	—	12.5	18.5	5	—	2.5	—
PFG-80*	80	M10x1.25	—	12.5	20.5	6	—	2.5	—
PFG-95*	95	M10x1.25	—	12.5	21	6	—	2.5	—
PFG-120*	120	14	14	20	25.5	6	4xØ8.7xØ40	1.5	—
PFG-150*	150	13	14	20	32.5	9	4xØ8.7xØ40	1.5	—
PFG-200*	200	13	12	20	37.5	13	4xØ8.7xØ40	1.5	—

* Cup material

Dimensions

A

**PFTM-5A thru
PFTM-15A**

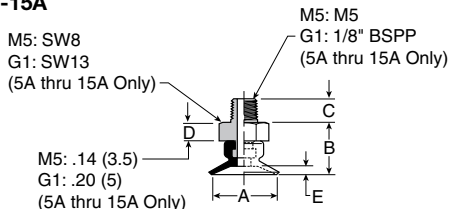

**PFTM-20B thru
PFTM-50**

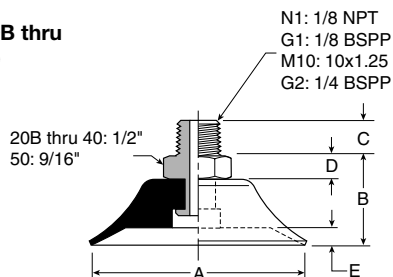

**PFTM-60 thru
PFTM-95**

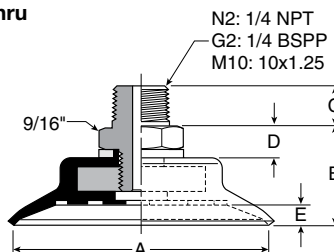

Dimensions (mm)

Model number	ØA	B	C (M3)	C (M5)	C (N1 / G1)	C (M10 / G2)	C (N2)	D	E
PFTM-5A-*†	5	10	—	4.5	8	—	—	See Dwg.	8
PFTM-6A-*†	6	10	—	4.5	8	—	—	See Dwg.	8
PFTM-8A-*†	8	10.5	—	4.5	8	—	—	See Dwg.	1.2
PFTM-10A-*†	10	11	—	4.5	8	—	—	See Dwg.	1.5
PFTM-15A-*†	15	11.5	—	4.5	8	—	—	See Dwg.	2
PFTM-20B-*†	20	17.5	—	—	8	10	—	5	2.5
PFTM-30-*†	30	17	—	—	8	10	—	5	2
PFTM-40-*†	40	19	—	—	8	10	—	5	3.5
PFTM-50-*†	50	20	—	—	8	10	—	5	4
PFTM-60-*†	60	23	—	—	—	10	15	7	5
PFTM-80-*†	80	25	—	—	—	10	15	7	6
PFTM-95-*†	95	25.5	—	—	—	10	15	7	6

* Cup material

† Thread size



Dimensions

PFTF-5A thru
PFTF-15A

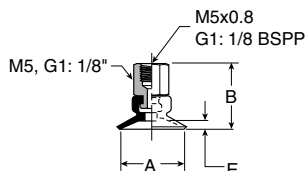

PFTF-20B thru
PFTF-50

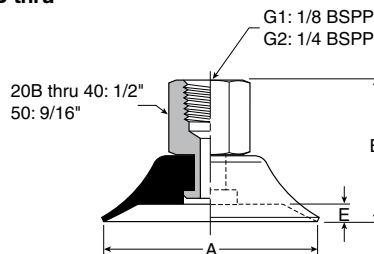

PFTF-60 thru
PFTF-95

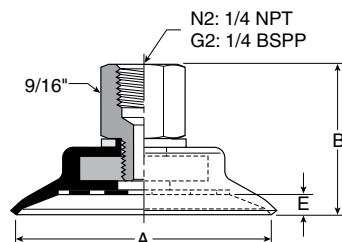

PFTF-120 thru
PFTF-200

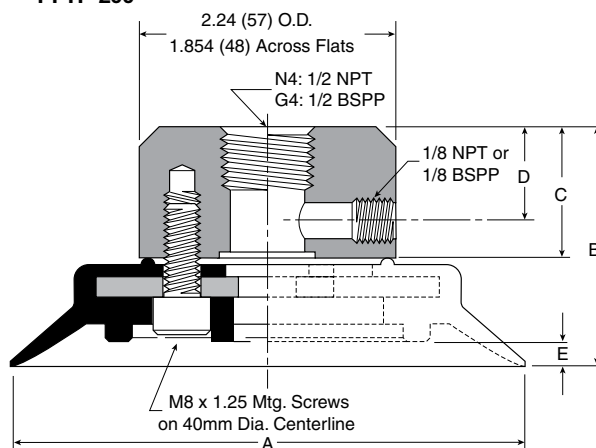

Dimensions (mm)

Model number	ØA	B	B (M5)	C	D	E
PFTF-5A-*†	5	14.5	20.5	—	—	.8
PFTF-6A-*†	6	14.5	20.5	—	—	.8
PFTF-8A-*†	8	15	21	—	—	1.2
PFTF-10A-*†	10	14.5	20.5	—	—	1.5
PFTF-15A-*†	15	16	22	—	—	2
PFTF-20B-*†	20	26.5	—	—	—	2.5
PFTF-30-*†	30	26	—	—	—	2
PFTF-40-*†	40	28	—	—	—	4
PFTF-50-*†	50	29	—	—	—	4
PFTF-60-*†	60	35.5	—	—	—	5
PFTF-80-*†	80	37.5	—	—	—	6
PFTF-95-*†	95	38	—	—	—	6
PFTF-120-*†	120	46.5	—	24	13	6
PFTF-150-*†	150	53.5	—	24	13	9
PFTF-200-*†	200	58.5	—	24	13	13

* Cup material
† Thread size

A

Dimensions

PFTK-5A thru PFTK-10A

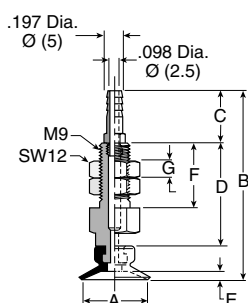

PFTK-15 thru PFTK-20

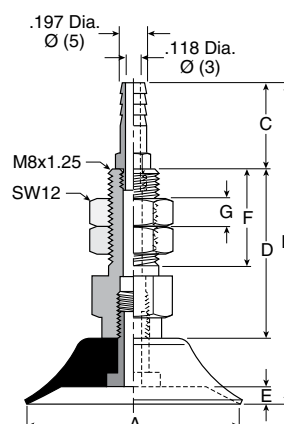

PFTK-30 thru PFTK-50

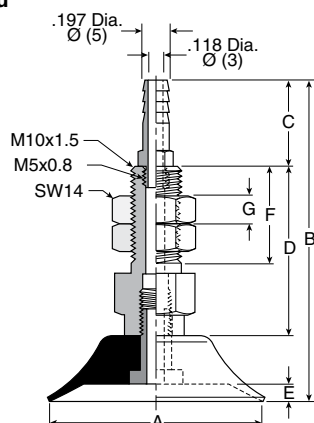

PFTK-60 thru PFTK-95

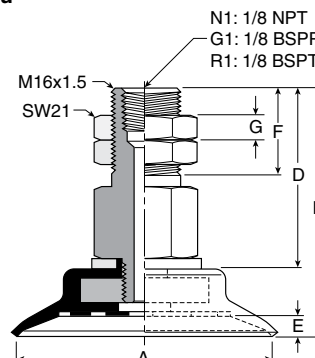

Dimensions (mm)

Model number	ØA	B	C	D	E	F	G	Wt g
PFTK-5A-*	5	30.5	10	14	.8	15.5	3	11
PFTK-6A-*	6	30.5	10	14	.8	15.5	3	11
PFTK-8A-*	8	31	10	14	1.2	15.5	3	11
PFTK-10A-*	10	46	16	22.5	1.5	15.5	3	15
PFTK-15-*	15	46	16	22	1.9	15	3	20
PFTK-20-*	20	48	16	22	2.3	15	5	20
PFTK-30-*	30	60	16	32	2	20	5	40
PFTK-40-*	40	62	16	32	3.5	20	5	40
PFTK-50-*	50	63	16	32	4	20	5	50
PFTK-60-*-†	60	58.5	—	42.5	5	20	6	130
PFTK-80-*-†	80	60.5	—	42.5	6	20	6	170
PFTK-95-*-†	95	61	—	42.5	6	20	6	220

* Cup material
† Vacuum port

Dimensions

PFYK-5A thru
PFYK-10A

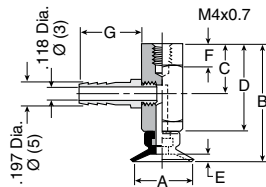

PFYK-15 thru
PFYK-20

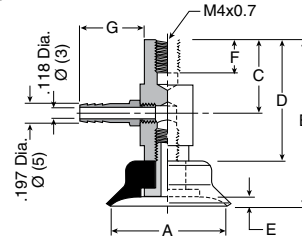

PFYK-30 thru
PFYK-50

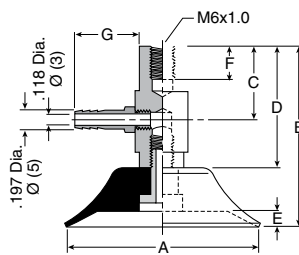

PFYK-60 thru
PFYK-95

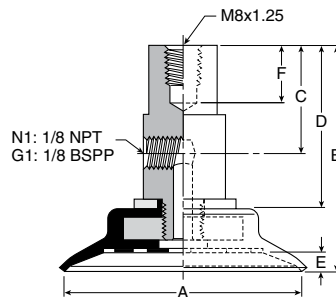

PFYK-120 thru
PFYK-200

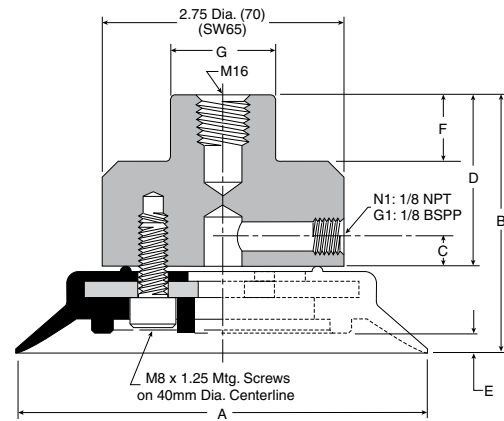

Dimensions (mm)

Model number	ØA	B	C	D	E	F	G	Wt g
PFYK-5A-*	5	29	13	22.5	.8	6	16	16
PFYK-6A-*	6	29	13	22.5	.8	6	16	16
PFYK-8A-*	8	29.5	13	22.5	1.2	6	16	16
PFYK-10A-*	10	30	13	22.5	1.5	6	16	16
PFYK-15-*	15	30	14	22	1.9	6	16	20
PFYK-20-*	20	32	14	22	2.3	6	16	20
PFYK-30-*	30	44	20	32	2	8	16	40
PFYK-40-*	40	46	20	32	3.5	8	16	50
PFYK-50-*	50	47	20	32	4	8	16	55
PFYK-60-*,†	60	58.5	28	40	5	11	—	120
PFYK-80-*,†	80	60.5	28	40	6	11	—	160
PFYK-95-*,†	95	61	28	40	6	11	—	210
PFYK-120-*,†	120	75.5	12	50	6	20	Dia. 30	640
PFYK-150-*,†	150	82.5	12	50	9	20	Dia. 30	910
PFYK-200-*,†	200	87.5	12	50	13	20	Dia. 30	1200

* Cup material
† Vacuum port



Dimensions

A

PFTYS5A thru
PFTYS15A

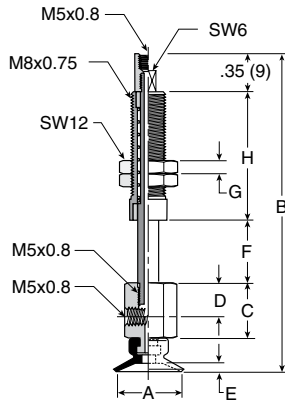

PFTYS20B thru
PFTYS50

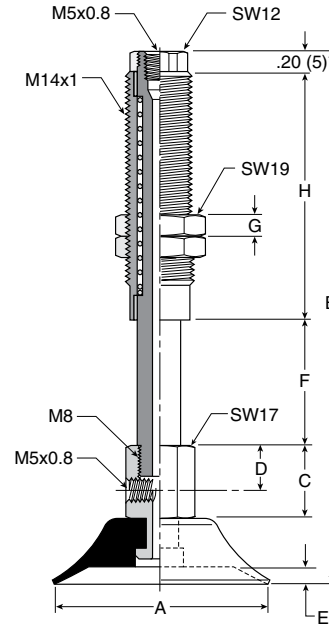

Dimensions (mm)

Model number	ØA	B	C	D	E	F	G	H	Wt g
PFTYS5A10*†	5	61.5	13	8	.8	10	3	23	18.5
PFTYS5A15*†	5	74	13	8	.8	15	3	30.5	21
PFTYS6A10*†	6	61.5	13	8	.8	10	3	23	18.5
PFTYS6A15*†	6	74	13	8	.8	15	3	30.5	21
PFTYS8A10*†	8	62	13	8	1.2	10	3	23	18.5
PFTYS8A15*†	8	74.5	13	8	1.2	15	3	30.5	21
PFTYS10A10*†	10	63	13	8	1.5	10	3	23	18.5
PFTYS10A15*†	10	75	13	8	1.5	15	3	30.5	21
PFTYS15A10*†	15	63.5	13	8	2	10	3	23	18.5
PFTYS15A15*†	15	75.5	13	8	2	15	3	30.5	21
PFTYS20B15*†	20	85.5	17	10	2.3	15	5	36	71
PFTYS20B30*†	20	122.5	17	10	2.3	30	5	58	96
PFTYS3015*†	30	85	17	10	2	15	5	36	72
PFTYS3030*†	30	122	17	10	2	30	5	58	97
PFTYS4015*†	40	87	17	10	3.5	15	5	36	76
PFTYS4030*†	40	124	17	10	3.5	30	5	58	101
PFTYS5015*†	50	88	17	10	4	15	5	36	85
PFTYS5030*†	50	125	17	10	4	30	5	58	110

* Cup material
† Vacuum port

Dimensions

PFTYS60 thru
PFTYS95

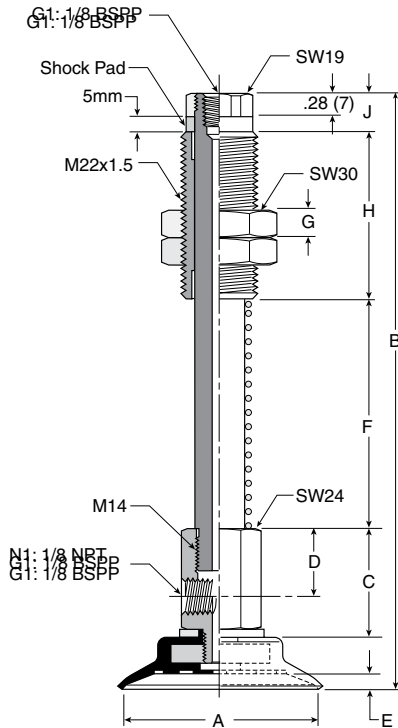

PFTYS120 thru
PFTYS200

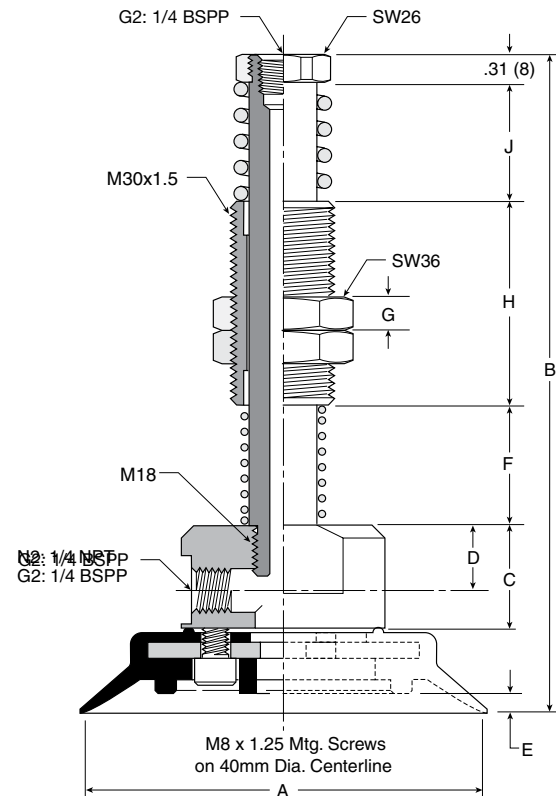

A

Dimensions (mm)

Model number	ØA	B	C	D	E	F	G	H	J	Wt g
PFTYS6030*†	60	153	32.5	20	5	45	10	50	12	282
PFTYS6050*†	60	178	32.5	20	5	70	10	50	12	316
PFTYS8030*†	80	155	32.5	20	6	45	10	50	12	310
PFTYS8050*†	80	180	32.5	20	6	70	10	50	12	344
PFTYS9530*†	95	156	32.5	20	6	45	10	50	12	350
PFTYS9550*†	95	181	32.5	20	6	70	10	50	12	384
PFTYS12020*†	120	192	32.5	18	6	35	10	60	35	1165
PFTYS12070*†	120	257	32.5	18	6	100	10	60	35	1246
PFTYS15020*†	150	199	32.5	18	9	35	10	60	35	1389
PFTYS15070*†	150	209	32.5	18	9	75	10	60	35	1471
PFTYS20020*†	200	204	32.5	18	13	35	10	60	35	1755
PFTYS20070*†	200	264	32.5	18	13	100	10	60	35	1836

* Cup material
† Vacuum port

A

These cups are for curved, corrugated, lightly textured surfaces and flexible product. Under vacuum, the bellow cup will collapse on contact and lift the product for a short distance. This inherent performance facilitates lifting and destack operations by breaking the vacuum between stacked product. The bellow style adds level compensation for applications that have inconsistent stack heights or uneven surfaces. The inclusive 30-degree rotation of the bellow helps maintain the vacuum seal when lifting sheet products that flex. Because of its shape however the bellows suction cup is not very well suitable for applications involving lifting vertical surfaces.



Features

- Bellows design for level compensation within restricted clearances
- Sheet separation for flexible and stacked products
- Soft seal lip for flexible products
- 10mm to 150mm diameters

Styles

- PBTM series male thread connector
- PBTB series female thread connector
- PBTK series barbed bulkhead
- PBYK series 90° barbed adapter
- PBTYS series bulkhead level compensator

Specifications

Cup material	Nitrile	Silicon	Urethane
Material code	NBR	SI	U
Operating temperature (°C)	-20° to +120°	-60° to +250°	-30° to +120°
Color	Black	White	Blue
Hardness, shore A (°Sh)	55 ±5	55 ±5	55 ±5

How to order

Cups assemblies and replacement cups are specified by cup diameter and material. Standard nitrile and silicon are listed on the following pages. To specify an alternative material, replace the cup material with alternative cup material code.

Example: To specify a cup assembly with urethane (U), replace (NBR) with (U) in the part number. PBTM-20B-NBR-G1 becomes PBTM-20B-U-G1. Inquire with factory for availability.

Application guide

Bellows

Flat surface, thin section	Flat surface, any section	Slightly bowed surface, thin section	Slightly bowed surface, any section	Bowed surface, thin section	Bowed surface, any section	Soft porous material, any section	Differences in heights and levels	Corrugated sheet handling	Not for vertical lift	Metal sheet handling

PBTM Series Male Thread Connector

Simple male connection for low profile positions secured to a plate or bracket. BSPP, NPT metric threads.
 Fitting material: aluminum.

Installation

Note:

When installing cup assemblies, use a sealant material to secure the assembly and prevent vacuum leakage.

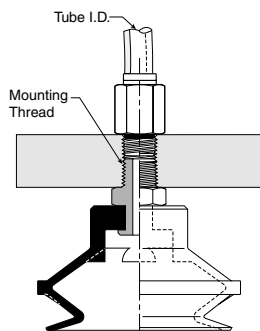

Cup diameter (mm)	Vacuum port	Complete assembly Nitrile (NBR)	Replacement cup Nitrile (NBR)	Complete assembly Silicon (SI)	Replacement cup Silicon (SI)	Replacement cup fitting
10	M5	PBTM-10A-NBR-M5	PBG-10A-NBR	PBTM-10A-SI-M5	PBG-10A-SI	FTM-5A-M5
10	1/8 BSPP	PBTM-10A-NBR-G1	PBG-10A-NBR	PBTM-10A-SI-G1	PBG-10A-SI	FTM-5A-G1
15	M5	PBTM-15A-NBR-M5	PBG-15A-NBR	PBTM-15A-SI-M5	PBG-15A-SI	FTM-5A-M5
15	1/8 BSPP	PBTM-15A-NBR-G1	PBG-15A-NBR	PBTM-15A-SI-G1	PBG-15A-SI	FTM-5A-G1
20	1/8 BSPP	PBTM-20B-NBR-G1	PBG-20B-NBR	PBTM-20B-SI-G1	PBG-20B-SI	FTM-20B-G1
20	1/4 BSPP	PBTM-20B-NBR-G2	PBG-20B-NBR	PBTM-20B-SI-G2	PBG-20B-SI	FTM-20B-G2
20	M10	PBTM-20B-NBR-M10	PBG-20B-NBR	PBTM-20B-SI-M10	PBG-20B-SI	FTM-20B-M10
20	1/8 NPT	PBTM-20B-NBR-N1	PBG-20B-NBR	PBTM-20B-SI-N1	PBG-20B-SI	FTM-20B-N1
30	1/8 BSPP	PBTM-30-NBR-G1	PBG-30-NBR	PBTM-30-SI-G1	PBG-30-SI	FTM-20B-G1
30	1/4 BSPP	PBTM-30-NBR-G2	PBG-30-NBR	PBTM-30-SI-G2	PBG-30-SI	FTM-20B-G2
30	M10	PBTM-30-NBR-M10	PBG-30-NBR	PBTM-30-SI-M10	PBG-30-SI	FTM-20B-M10
30	1/8 NPT	PBTM-30-NBR-N1	PBG-30-NBR	PBTM-30-SI-N1	PBG-30-SI	FTM-20B-N1
40	1/8 BSPP	PBTM-40-NBR-G1	PBG-40-NBR	PBTM-40-SI-G1	PBG-40-SI	FTM-20B-G1
40	1/4 BSPP	PBTM-40-NBR-G2	PBG-40-NBR	PBTM-40-SI-G2	PBG-40-SI	FTM-20B-G2
40	M10	PBTM-40-NBR-M10	PBG-40-NBR	PBTM-40-SI-M10	PBG-40-SI	FTM-20B-M10
40	1/8 NPT	PBTM-40-NBR-N1	PBG-40-NBR	PBTM-40-SI-N1	PBG-40-SI	FTM-20B-N1
50	1/8 BSPP	PBTM-50-NBR-G1	PBG-50-NBR	PBTM-50-SI-G1	PBG-50-SI	FTM-50-G1
50	1/4 BSPP	PBTM-50-NBR-G2	PBG-50-NBR	PBTM-50-SI-G2	PBG-50-SI	FTM-50-G2
50	1/8 NPT	PBTM-50-NBR-N1	PBG-50-NBR	PBTM-50-SI-N1	PBG-50-SI	FTM-50-N1
75	1/4 BSPP	PBTM-75-NBR-G2	PBG-75-NBR	PBTM-75-SI-G2	PBG-75-SI	FTM-60-G2
75	M10	PBTM-75-NBR-M10	PBG-75-NBR	PBTM-75-SI-M10	PBG-75-SI	FTM-60-M10
75	1/4 NPT	PBTM-75-NBR-N2	PBG-75-NBR	PBTM-75-SI-N2	PBG-75-SI	FTM-60-N2

A

PBTF Series Female Thread Connector

Simple female connection for low profile positions secured to a plate or bracket. BSPP, NPT metric threads.

Fitting material: aluminum.

Installation

Note:

When installing cup assemblies, use a sealant material to secure the assembly and prevent vacuum leakage.

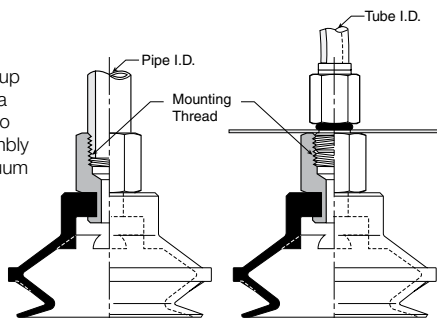

Cup diameter (mm)	Vacuum port	Complete assembly Nitrile (NBR)	Replacement cup Nitrile (NBR)	Complete assembly Silicon (SI)	Replacement cup Silicon (SI)	Replacement cup fitting
10	1/8 BSPP	PBTF-10A-NBR-G1	PBG-10A-NBR	PBTF-10A-SI-G1	PBG-10A-SI	FTF-5A-G1
10	M5	PBTF-10A-NBR-M5	PBG-10A-NBR	PBTF-10A-SI-M5	PBG-10A-SI	FTF-5A-M5
15	1/8 BSPP	PBTF-15A-NBR-G1	PBG-15A-NBR	PBTF-15A-SI-G1	PBG-15A-SI	FTF-5A-G1
15	M5	PBTF-15A-NBR-M5	PBG-15A-NBR	PBTF-15A-SI-M5	PBG-15A-SI	FTF-5A-M5
20	1/8 BSPP	PBTF-20B-NBR-G1	PBG-20B-NBR	PBTF-20B-SI-G1	PBG-20B-SI	FTF-20B-G1
20	1/8 NPT	PBTF-20B-NBR-N1	PBG-20B-NBR	PBTF-20B-SI-N1	PBG-20B-SI	FTF-20B-N1
30	1/8 BSPP	PBTF-30-NBR-G1	PBG-30-NBR	PBTF-30-SI-G1	PBG-30-SI	FTF-20B-G1
30	1/8 NPT	PBTF-30-NBR-N1	PBG-30-NBR	PBTF-30-SI-N1	PBG-30-SI	FTF-20B-N1
30	1/4 BSPP	PBTF-30-NBR-G2	PBG-30-NBR	PBTF-30-SI-G2	PBG-30-SI	FTF-20B-G2
40	1/8 BSPP	PBTF-40-NBR-G1	PBG-40-NBR	PBTF-40-SI-G1	PBG-40-SI	FTF-20B-G1
40	1/8 NPT	PBTF-40-NBR-N1	PBG-40-NBR	PBTF-40-SI-N1	PBG-40-SI	FTF-20B-N1
40	1/4 BSPP	PBTF-40-NBR-G2	PBG-40-NBR	PBTF-40-SI-G2	PBG-40-SI	FTF-20B-G2
50	1/8 BSPP	PBTF-50-NBR-G1	PBG-50-NBR	PBTF-50-SI-G1	PBG-50-SI	FTF-50-G1
50	1/4 BSPP	PBTF-50-NBR-G2	PBG-50-NBR	PBTF-50-SI-G2	PBG-50-SI	FTF-50-G2
50	1/8 NPT	PBTF-50-NBR-N1	PBG-50-NBR	PBTF-50-SI-N1	PBG-50-SI	FTF-50-N1
75	1/4 BSPP	PBTF-75-NBR-G2	PBG-75-NBR	PBTF-75-SI-G2	PBG-75-SI	FTF-60-G2
75	1/4 NPT	PBTF-75-NBR-N2	PBG-75-NBR	PBTF-75-SI-N2	PBG-75-SI	FTF-60-N2
110	1/2 BSPP	PBTF-110-NBR-G4	PBG-110-NBR	PBTF-110-SI-G4	PBG-110-SI	FTF-120-G4
110	1/2 NPT	PBTF-110-NBR-N4	PBG-110-NBR	PBTF-110-SI-N4	PBG-110-SI	FTF-120-N4
150	1/2 BSPP	PBTF-150-NBR-G4	PBG-150-NBR	PBTF-150-SI-G4	PBG-150-SI	FTF-120-G4
150	1/2 NPT	PBTF-150-NBR-N4	PBG-150-NBR	PBTF-150-SI-N4	PBG-150-SI	FTF-120-N4

PBTK Series Barbed Bulkhead

Top stem connectors secured with jam nuts and allow tubing connections at the top side. Fitting materials: nickel plated brass.

Installation

Note:
 When installing cup assemblies, use a sealant material to secure the assembly and prevent vacuum leakage.

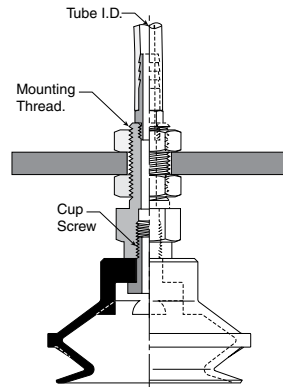

Cup diameter (mm)	Vacuum port	Complete assembly Nitrile (NBR)	Replacement cup Nitrile (NBR)	Complete assembly Silicon (SI)	Replacement cup Silicon (SI)	Replacement cup fitting
10	Barb	PBTK-10A-NBR	PBG-10A-NBR	PBTK-10A-SI	PBG-10A-SI	FTK-5A
15	Barb	PBTK-15A-NBR	PBG-15A-NBR	PBTK-15A-SI	PBG-15-SI	FTK-5A
20	Barb	PBTK-20-NBR	PBG-20-NBR	PBTK-20-SI	PBG-20-SI	FTK-20
30	Barb	PBTK-30-NBR	PBG-30-NBR	PBTK-30-SI	PBG-30-SI	FTK-25
40	Barb	PBTK-40-NBR	PBG-40-NBR	PBTK-40-SI	PBG-40-SI	FTK-25
50	Barb	PBTK-50-NBR	PBG-50-NBR	PBTK-50-SI	PBG-50-SI	FTK-50
75	1/8 BSPP	PBTK-75-NBR-G1	PBG-75-NBR	PBTK-75-SI-G1	PBG-75-SI	FTK-60-G1
75	1/8 NPT	PBTK-75-NBR-N1	PBG-75-NBR	PBTK-75-SI-N1	PBG-75-SI	FTK-60-N1

A

PBYK Series 90° Barbed Adapter

Side stem connectors allow you to secure the stem with a bolt through a plate or "L" bracket to allow the tube connection from the side port. Fitting material: nickel plated brass.

Installation

Note:

When installing cup assemblies, use a sealant material to secure the assembly and prevent vacuum leakage.

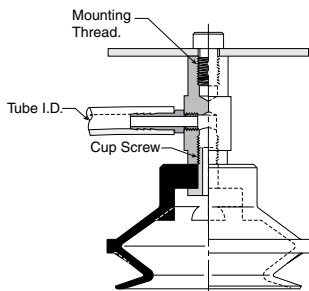

Cup diameter (mm)	Vacuum port	Complete assembly Nitrile (NBR)	Replacement cup Nitrile (NBR)	Complete assembly Silicon (SI)	Replacement cup Silicon (SI)	Replacement cup fitting
10	Barb	PBYK-10A-NBR	PBG-10A-NBR	PBYK-10A-SI	PBG-10A-SI	FYK-5A
15	Barb	PBYK-15A-NBR	PBG-15A-NBR	PBYK-15A-SI	PBG-15A-SI	FYK-15
20	Barb	PBYK-20-NBR	PBG-20-NBR	PBYK-20-SI	PBG-20-SI	FYK-20
30	Barb	PBYK-30-NBR	PBG-30-NBR	PBYK-30-SI	PBG-30-SI	FYK-25
40	Barb	PBYK-40-NBR	PBG-40-NBR	PBYK-40-SI	PBG-40-SI	FYK-25
50	Barb	PBYK-50-NBR	PBG-50-NBR	PBYK-50-SI	PBG-50-SI	FYK-50
75	1/8 BSPP	PBYK-75-NBR-G1	PBG-75-NBR	PBYK-75-SI-G1	PBG-75-SI	FYK-60-G1
75	1/8 NPT	PBYK-75-NBR-N1	PBG-75-NBR	PBYK-75-SI-N1	PBG-75-SI	FYK-60-N1
110	1/8 BSPP	PBYK-110-NBR-G1	PBG-110-NBR	PBYK-110-SI-G1	PBG-110-SI	FYK-120-G1
110	1/8 NPT	PBYK-110-NBR-N1	PBG-110-NBR	PBYK-110-SI-N1	PBG-110-SI	FYK-120-N1
150	1/8 BSPP	PBYK-150-NBR-G1	PBG-150-NBR	PBYK-150-SI-G1	PBG-150-SI	FYK-120-G1
150	1/8 NPT	PBYK-150-NBR-N1	PBG-150-NBR	PBYK-150-SI-N1	PBG-150-SI	FYK-120-N1

PBTYS Series Bulkhead Level Compensator

303 stainless steel construction secured with jam nuts. Spring biased compensators can absorb impacts of down-strokes and adjust for different levels of pick up points. 303 stainless corrosion resistant materials with drymet bushings increases the strength and life.

Installation

Note:

When installing cup assemblies, use a sealant material to secure the assembly and prevent vacuum leakage. Shown are interchangeable connectors & plugs for port connections.

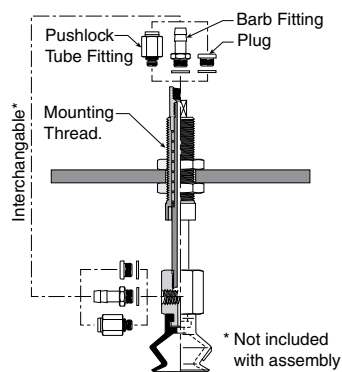

Cup dia. (mm)	Vacuum port	Stroke (mm)	Spring compression Force lbf (N)		Cup material Nitrile assembly (NBR)	Replacement cup Nitrile (NBR)	Cup material Silicon assembly (SI)	Replacement cup Silicon (SI)	Level Compensator P/N
			0%	100%					
10	M5	10	.11 (.49)	.13 (.59)	PBTYS10A10NBRM5	PBG-10A-NBR	PBTYS10A10SIM5	PBG-10A-SI	FTYS-5A-10-M5
10	M5	15	.11 (.49)	.13 (.59)	PBTYS10A15NBRM5	PBG-10A-NBR	PBTYS10A15SIM5	PBG-10A-SI	FTYS-5A-15-M5
15	M5	10	.11 (.49)	.13 (.59)	PBTYS15A10NBRM5	PBG-15A-NBR	PBTYS15A10SIM5	PBG-15A-SI	FTYS-5A-10-M5
15	M5	15	.11 (.49)	.13 (.59)	PBTYS15A15NBRM5	PBG-15A-NBR	PBTYS15A15SIM5	PBG-15A-SI	FTYS-5A-15-M5
20	M5	15	.56 (2.5)	.79 (3.4)	PBTYS20B15NBRM5	PBG-20B-NBR	PBTYS20B15SIM5	PBG-20B-SI	FTYS-20B-15-M5
20	M5	30	.56 (2.5)	1.2 (4.9)	PBTYS20B30NBRM5	PBG-20B-NBR	PBTYS20B30SIM5	PBG-20B-SI	FTYS-20B-30-M5
30	M5	15	.56 (2.5)	.79 (3.4)	PBTYS3015NBRM5	PBG-30-NBR	PBTYS3015SIM5	PBG-30-SI	FTYS-20B-15-M5
30	M5	30	.56 (2.5)	1.2 (4.9)	PBTYS3030NBRM5	PBG-30-NBR	PBTYS3030SIM5	PBG-30-SI	FTYS-20B-30-M5
40	M5	15	.56 (2.5)	.79 (3.4)	PBTYS4015NBRM5	PBG-40-NBR	PBTYS4015SIM5	PBG-40-SI	FTYS-20B-15-M5
40	M5	30	.56 (2.5)	1.2 (4.9)	PBTYS4030NBRM5	PBG-40-NBR	PBTYS4030SIM5	PBG-40-SI	FTYS-20B-30-M5
50	M5	15	.56 (2.5)	1.2 (4.9)	PBTYS5015NBRM5	PBG-50-NBR	PBTYS5015SIM5	PBG-50-SI	FTYS-50-15-M5
50	M5	30	.67 (2.9)	1.4 (5.9)	PBTYS5030NBRM5	PBG-50-NBR	PBTYS5030SIM5	PBG-50-SI	FTYS-50-30-M5
75	1/8 BSPP	30	1.6 (6.8)	3.6 (15.6)	PBTYS7530NBRG1	PBG-75-NBR	PBTYS7530SIG1	PBG-75-SI	FTYS-60-30-G1
75	1/8 BSPP	50	1.9 (8.3)	4.5 (19.6)	PBTYS7550NBRG1	PBG-75-NBR	PBTYS7550SIG1	PBG-75-SI	FTYS-60-50-G1
110	1/4 BSPP	20	3.6 (15.6)	6.8 (29)	PBTYS12020NBRG2	PBG-110-NBR	PBTYS11020SIG2	PBG-110-SI	FTYS-120-20-G2
110	1/4 BSPP	50	3.4 (14.7)	6.8 (29)	PBTYS12050NBRG2	PBG-110-NBR	PBTYS11050SIG2	PBG-110-SI	FTYS-120-50-G2
150	1/4 BSPP	20	3.6 (15.6)	6.8 (29)	PBTYS15020NBRG2	PBG-150-NBR	PBTYS15020SIG2	PBG-150-SI	FTYS-120-20-G2
150	1/4 BSPP	50	3.4 (14.7)	6.8 (29)	PBTYS15050NBRG2	PBG-150-NBR	PBTYS15050SIG2	PBG-150-SI	FTYS-120-50-G2

A

Applications

- Round objects
- Uneven surfaces
- Curved product
- Level compensation
- Flexible product
- Soft seal lip

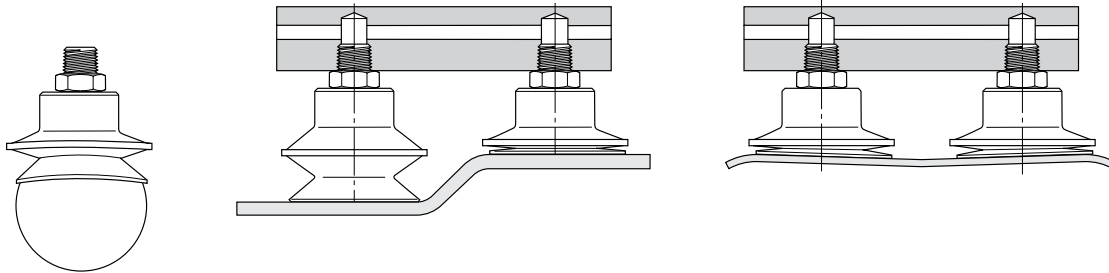

Main data for bellows PBG cups

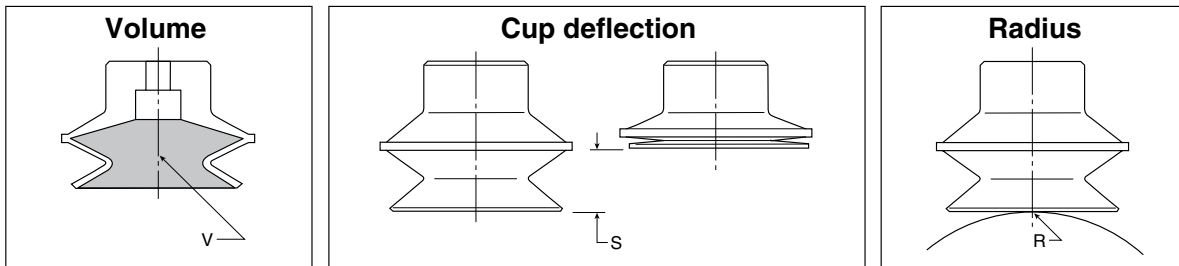

Model number	Cup diameter mm	Area cm ²	Volume (V) liters	Lifting force @60% (N)		Cup deflection (S) mm	Radius (R) mm
PBG-10A-*	10	0.79	.0002	4.80	—	4	4
PBG-15A-*	15	1.77	.0007	10.80	—	6	6
PBG-20-*	20	3.14	.001	19.20	—	9	8
PBG-20B-*	20	3.14	.001	19.20	—	9	8
PBG-30-*	30	7.07	.004	43.2	—	13	15
PBG-40-*	40	12.60	.009	76.9	—	13	30
PBG-50-*	50	19.60	.026	120	—	20	40
PBG-75-*	75	44.02	.076	270	—	22	70
PBG-110-*	110	95.00	.111	434	—	29	100
PBG-150-*	150	176.70	.260	1081	—	38	130

* Cup material

PBG Series Replacement Cup Dimensions

PBG-10A and PBG-20B

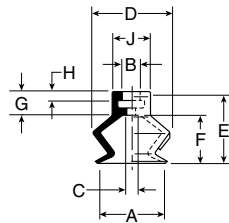

PBG-20 thru PBG-40

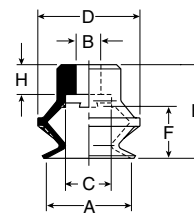

PBG-50

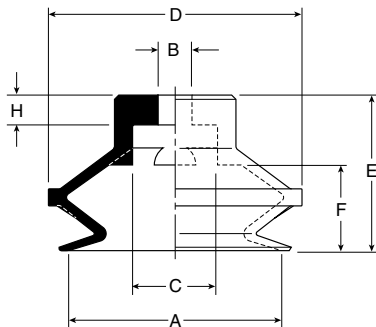

PBG-75

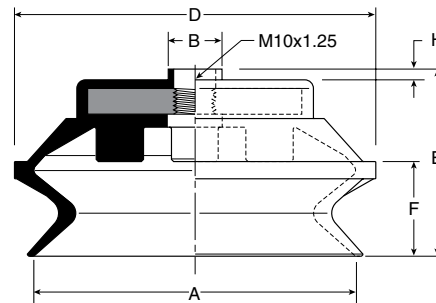

PBG-110

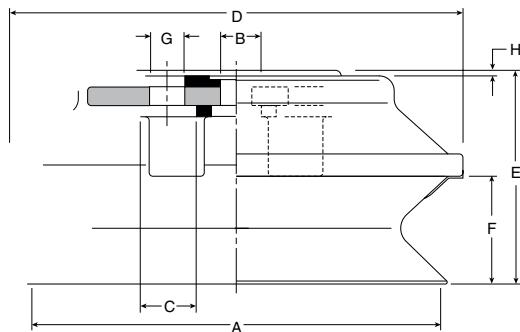

PBG-150

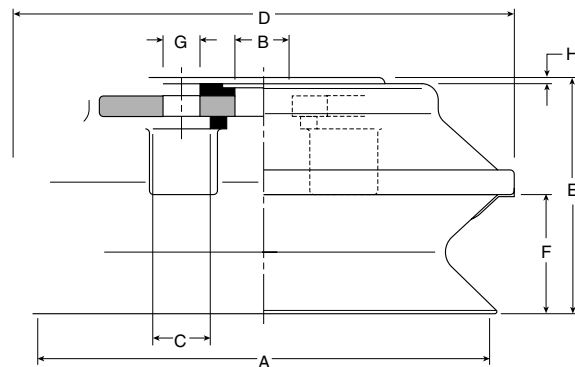

Dimensions (mm)

Model number	ØA	ØB	ØC	ØD	E	F	G	H	ØJ
PBG-10A-*	10.6	4	2	12.4	13.5	7.5	6	2	6
PBG-15A-*	15	4	4	17	16	10	6	2	6
PBG-20B-*	20	6	10.8	24	22	12	—	7	—
PBG-20-*	20	4.6	10.8	24	19.5	12	—	4.5	—
PBG-30-*	30	5.8	10.8	36	30.5	17	—	7	—
PBG-40-*	40	5.8	10.8	46	30.5	15.5	—	7	—
PBG-50-*	50	7.8	19.8	59.5	36.5	20	—	7	—
PBG-75-*	75	12.5	—	84	43.5	22	—	2.5	—
PBG-110-*	110	14	14	122	57.5	29	—	1.5	—
PBG-150-*	150	20	14	167	76.5	38	4xØ9xØ40	1.5	—

* Cup material



A

Dimensions

**PBTM-10A thru
PBTM-15**

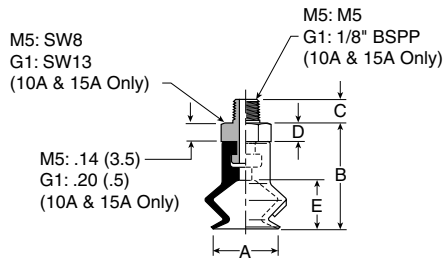

**PBTM-20B thru
PBTM-50**

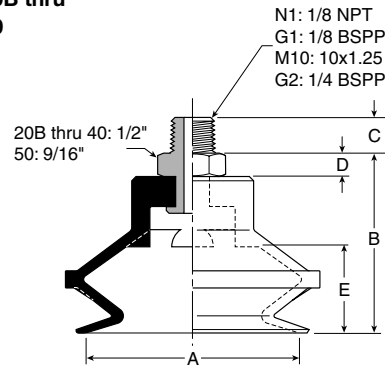

PBTM-75

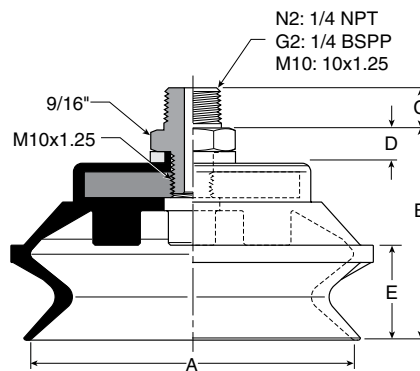

Dimensions (mm)

Model number	ØA	B	C (M5)	C (N1 / G1)	C (M10 / G2)	C (N2)	D	E
PBTM-10A-*†	10	17	4.5	8	—	—	See Dwg.	7.5
PBTM-15A-*†	15	19.5	4.5	8	—	—	See Dwg.	10
PBTM-20B-*†	20	27	—	8	10	—	5	12
PBTM-30-*†	30	35.5	—	8	10	—	5	17
PBTM-40-*†	40	35.5	—	8	10	—	5	15.5
PBTM-50-*†	50	41.5	—	8	10	—	5	20
PBTM-75-*†	95	50.5	—	—	10	15	7	22

* Cup material
† Thread size

Dimensions

PBTF-10A thru
PBTF-15A

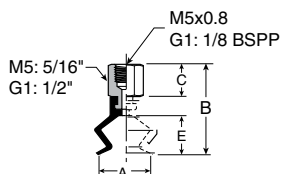

PBTF-20B thru
PBTF 50

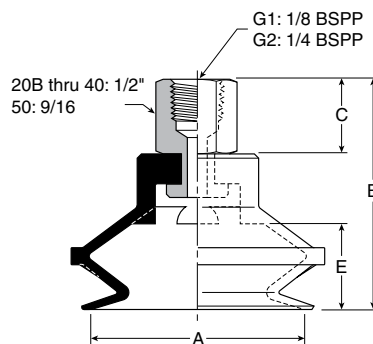

PBTF-110 thru
PBTF-150

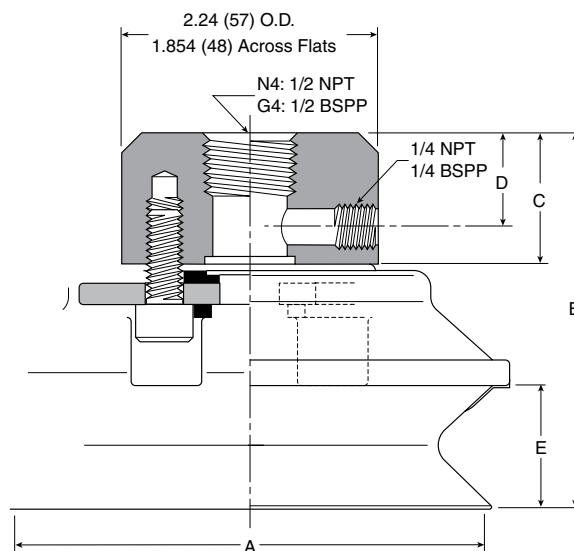

PBTF-75

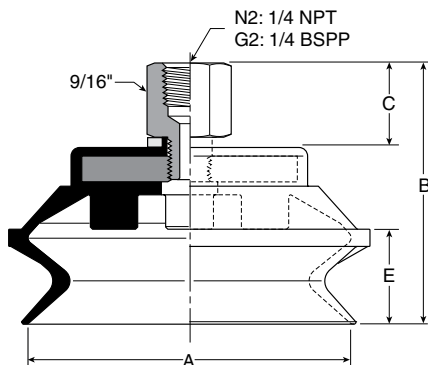

Dimensions (mm)

Model number	ØA	B	B (M5)	C	C (M5)	D	E
PBTF-10A- [*] †	10	21.5	27.5	8	14	—	7.5
PBTF-15A- [*] †	15	24	30	8	14	—	10
PBTF-20B- [*] †	20	36	—	14	—	—	12
PBTF-30- [*] †	30	44.5	—	14	—	—	17
PBTF-40- [*] †	40	44.5	—	14	—	—	15.5
PBTF-50- [*] †	50	50.5	—	14	—	—	20
PBTF-75- [*] †	95	60.5	—	19.5	—	—	22
PBTF-110- [*] †	120	78	—	24	—	13	29
PBTF-150- [*] †	150	97	—	24	—	13	38

^{*} Cup material
[†] Thread size



Dimensions

A

**PBTK-10A thru
PBTK-15A**

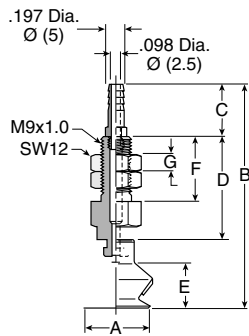

PBTK-20

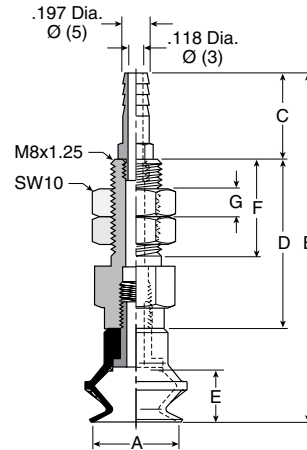

**PBTK-30 thru
PBTK-50**

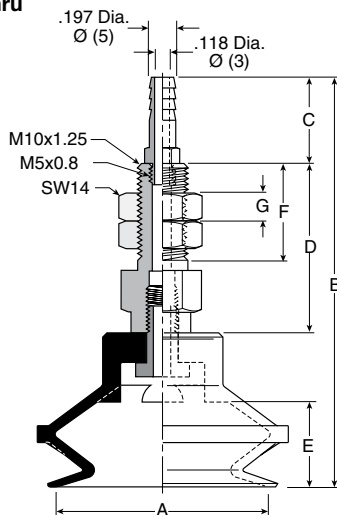

PBTK-75

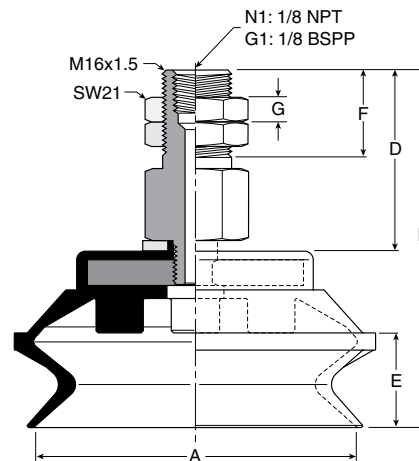

Dimensions (mm)

Model number	ØA	B	C	D	E	F	G	Wt g
PBTK-10A-*	10	52	10	22.5	7.5	6	15.5	15
PBTK-15A-*	15	54.5	10	22.5	10	6	15.5	15
PBTK-20-*	20	57.5	16	22	12	6	15	21
PBTK-30-*	30	78.5	16	32	17	6	20	45
PBTK-40-*	40	78.5	16	32	15.5	6	20	48
PBTK-50-*	50	84.5	16	32	20	6	20	62
PBTK-75-*.†	95	83.5	—	42.5	22	11	—	186

* Cup material
† Vacuum port

Dimensions

PBYK-10A thru
PBYK-15A

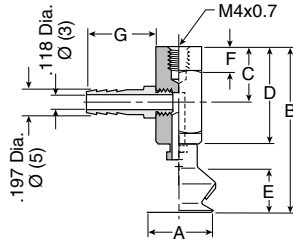

PBYK-20 thru
PBYK-50

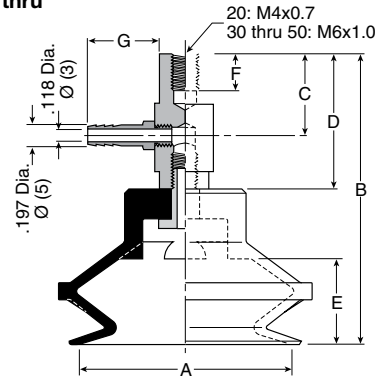

PBYK-75

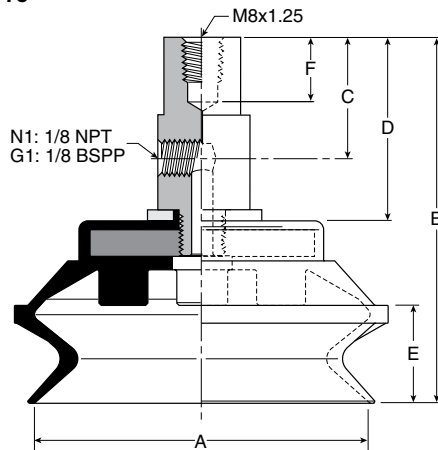

PBYK-110 thru
PBYK-150

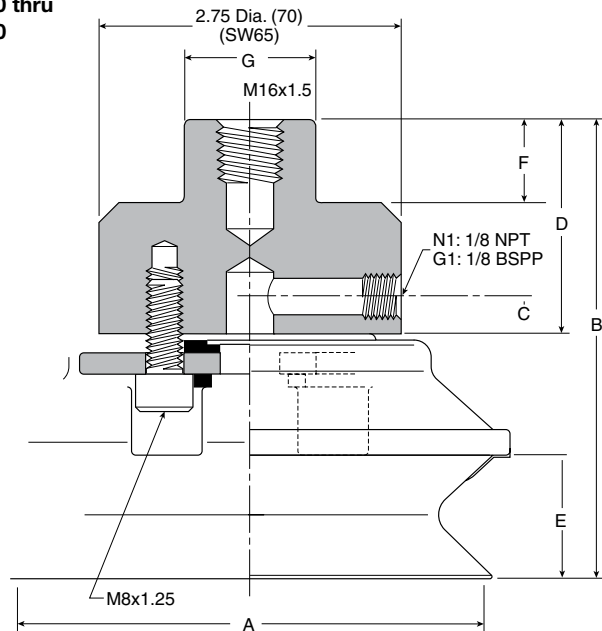

Dimensions (mm)

Model number	ØA	B	C	D	E	F	G	Wt g
PBYK-10A-*	10	36	13	22.5	7.5	6	16	16
PBYK-15A-*	15	38.5	13	22.5	10	6	16	16
PBYK-20-*	20	41.5	14	22	12	6	16	21
PBYK-30-*	30	62.5	20	32	17	6	16	45
PBYK-40-*	40	62.5	20	32	15.5	6	16	58
PBYK-50-*	50	68.5	20	32	20	6	16	67
PBYK-75-*.†	95	83.5	28	42.5	22	11	—	176
PBYK-110-*.†	120	106	12	50	29	20	Dia. 30	670
PBYK-150-*.†	150	125	12	50	38	20	Dia. 30	1180

* Cup material
† Vacuum port



Dimensions

A

PBTYS10A thru PBTYS15A1

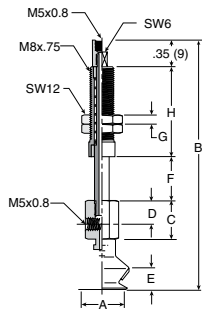

PBTYS20B thru PBTYS50

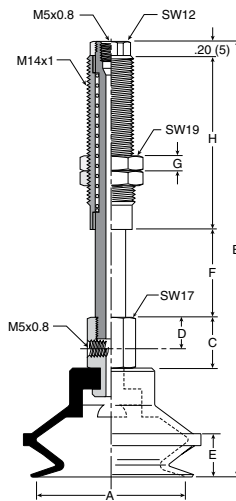

PBTYS75

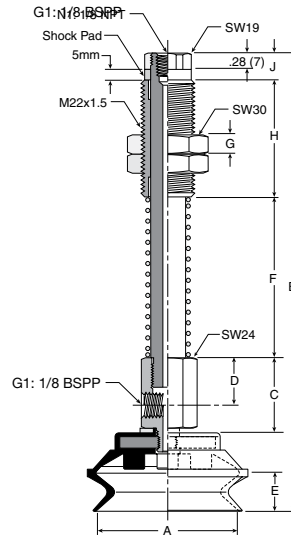

PBTYS110 thru PBTYS150

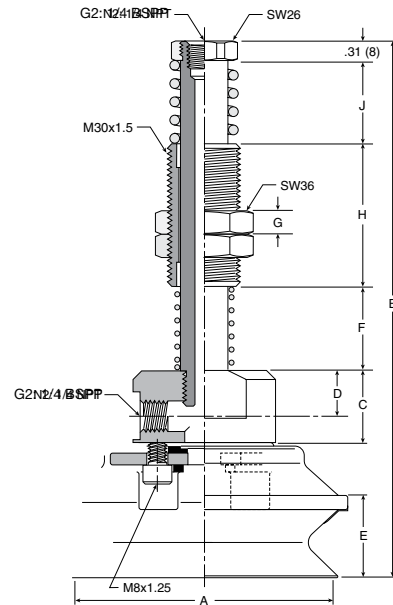

Dimensions (mm)

Model number	ØA	B	C	D	E	F	G	H	J	Wt g
PBTYS10A10*	10	68.5	13	8	7.5	10	3	23	—	18.5
PBTYS10A15*	10	81	13	8	7.5	15	3	30.5	—	21
PBTYS15A10*	15	71	13	8	10	10	3	23	—	18.5
PBTYS15A15*	15	83.5	13	8	10	15	3	30.5	—	21
PBTYS20B15*	20	99	17	10	12	15	5	36	—	72
PBTYS20B30*	20	136	17	10	12	30	5	58	—	97
PBTYS3015*†	30	103.5	17	10	17	15	5	36	—	97
PBTYS3030*†	30	140.5	17	10	17	30	5	58	—	102
PBTYS4015*†	40	103.5	17	10	15.5	15	5	36	—	83
PBTYS4030*†	40	140.5	17	10	15.5	30	5	58	—	108
PBTYS5015*†	50	109.5	17	10	20	15	5	36	—	97
PBTYS5030*†	50	146.5	17	10	20	30	5	58	—	122
PBTYS7530*†	75	178	32.5	20	22	45	10	50	12	339
PBTYS7550*†	75	203	32.5	20	22	70	10	50	12	373
PBTYS11020*†	110	224	30	18	29	35	10	60	35	1194
PBTYS11070*†	110	289	30	18	29	100	10	60	35	1276
PBTYS15020*†	150	243	30	18	38	35	10	60	35	1704
PBTYS15070*†	150	308	30	18	38	100	10	60	35	1786

* Cup material
† Vacuum port



The PAG Cups are ideal for paper feeding, plastic bags and foil. The choice between the 20A & 20B, 30 & 30B is application dependent. The 20A & 30B cups have a thinner lip design than the 20B & 30 cups. This thinner lip design is more suited to products with micron thickness.



Features

- Bellows design for level compensation within restricted clearances
- Sheet separation for flexible and stacked products
- Soft seal lip for flexible products
- 10mm to 50mm diameters

Styles

- PATM Series Male Thread Connector
- PATK Series Barbed Bulkhead
- PAYK Series 90° Barbed Adapter

Specifications

Cup material	Nitrile	Nitrile ESD*	Silicon	Silicon ESD*	Urethane
Material code	NBR	NBRE	SI	SIE	U
Operating temperature (°C)	-20° to +120°	-30° to +120°	-60° to +250°	-60° to +250°	-30° to +120°
Color	Black	Black / Blue Dot	White	Black / Red Dot	Blue
Hardness, shore A (°Sh)	55 ±5	70 ±5	55 ±5	55 ±5	55 ±5
Electrical resistance (Ωm)	—	800 to 1000	—	800 to 1000	—

* ESD: Electric Static Dissipative Material

How to order

Cups Assemblies and replacement cups are specified by Cup Diameter and Material. Standard Nitrile and silicon are listed on the following pages. To specify an alternative material, replace the cup material with alternative cup material code.

Example: To specify a cup assembly with Urethane (U), replace (NBR) with (U) in the part number. PFTM-20B-NBR-G1 becomes PFTM-20B-U-G1. Inquire with factory for availability.

Application guide

Thin – Smooth Surfaces



Flat surface,
thin section



A

PATM Series Male Thread Connector

Simple male connection for low profile positions secured to a plate or bracket.
 Fitting Material: Aluminium.

Installation

Note:

When installing cup assemblies, use a sealant material to secure the assembly and prevent vacuum leakage.

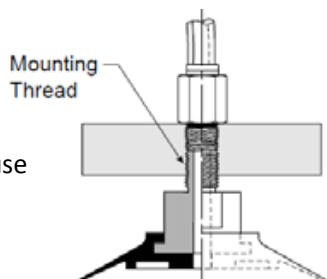

Cup Diameter (mm)	Vacuum Port	Complete Assembly Nitrile (NBR)	Replacement Cup Nitrile (NBR)	Complete Assembly Silicon (SI)	Replacement Cup Silicon (SI)	Replacement cup fitting
10	M5	PATM-10A-NBR-M5	PAG-10A-NBR	PATM-10A-SI-M5	PAG-10A-SI	FTM-5A-M5
15	M5	PATM-15A-NBR-M5	PAG-15A-NBR	PATM-15A-SI-M5	PAG-15A-SI	FTM-5A-M5
20	M5	PATM-20A-NBR-M5	PAG-20A-NBR	PATM-20A-SI-M5	PAG-20A-SI	FTM-5A-M5
25*	M6		PAG-25-NBR		PAG-25-SI	
30*	M6		PAG-30-NBR		PAG-30-SI	
40*	M6		PAG-40-NBR		PAG-40-SI	
50*	M6		PAG-50-NBR		PAG-50-SI	

* : From diameter 25 to 50, the PAG cup include the cup fitting

PATK Series Barbed Bulkhead

Top stem connectors secured with jam nuts and allow tubing connections at the top side. Nickel plated brass materials.

Installation

Note:

When installing cup assemblies, use a sealant material to secure the assembly and prevent vacuum leakage.

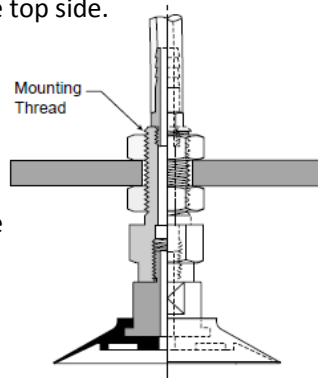

Cup Diameter (mm)	Vacuum Port	Complete Assembly Nitrile (NBR)	Replacement Cup Nitrile (NBR)	Complete Assembly Silicon (SI)	Replacement Cup Silicon (SI)	Replacement cup fitting
10	Bard	PATK-10A-NBR	PAG-10A-NBR	PATK-10A-SI	PAG-10A-SI	FTK-5A
15	Bard	PATK-15A-NBR	PAG-15A-NBR	PATK-15A-SI	PAG-15A-SI	FTK-5A
20	Bard	PATK-20A-NBR	PAG-20A-NBR	PATK-20A-SI	PAG-20A-SI	FTK-5A
25	Bard	PATK-25-NBR	PAG-25-NBR	PATK-25-SI	PAG-25-SI	FTK-20B
30	Bard	PATK-30-NBR	PAG-30-NBR	PATK-30-SI	PAG-30-SI	FTK-20B
40	Bard	PATK-40-NBR	PAG-40-NBR	PATK-40-SI	PAG-40-SI	FTK-20B
50	Bard	PATK-50-NBR	PAG-50-NBR	PATK-50-SI	PAG-50-SI	FTK-20B

A

PAYK Series 90° Barbed Adapte

Side stem connectors allow you to secure the stem with a bolt through a plate or “L” bracket to allow the tube connection from the side port. Nickel plated brass materials.

Installation

Note:

When installing cup assemblies, use a sealant material to secure the assembly and prevent vacuum leakage.

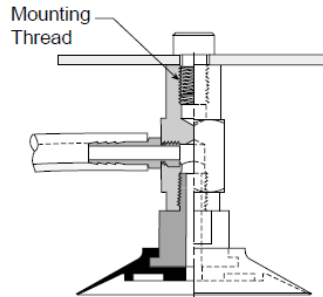

Cup Diameter (mm)	Vacuum Port	Complete Assembly Nitrile (NBR)	Replacement Cup Nitrile (NBR)	Complete Assembly Silicon (SI)	Replacement Cup Silicon (SI)	Replacement cup fitting
10	Bard	PAYK-10A-NBR	PAG-10A-NBR	PAYK-10A-SI	PAG-10A-SI	FYK-5A
15	Bard	PAYK-15A-NBR	PAG-15A-NBR	PAYK-15A-SI	PAG-15A-SI	FYK-5A
20	Bard	PAYK-20A-NBR	PAG-20A-NBR	PAYK-20A-SI	PAG-20A-SI	FYK-5A
25	Bard	PAYK-25-NBR	PAG-25-NBR	PAYK-25-SI	PAG-25-SI	FYK-20B
30	Bard	PAYK-30-NBR	PAG-30-NBR	PAYK-30-SI	PAG-30-SI	FYK-20B
40	Bard	PAYK-40-NBR	PAG-40-NBR	PAYK-40-SI	PAG-40-SI	FYK-20B
50	Bard	PAYK-50-NBR	PAG-50-NBR	PAYK-50-SI	PAG-50-SI	FYK-20B

Applications

- Products With Smooth Surfaces
- Products With Micron Thickness
- When Opening Plastic or Paper Bags, Offset Cups



A

Main data for fat PAG cups

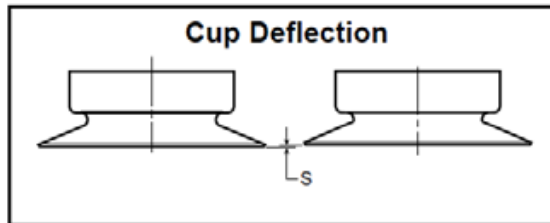
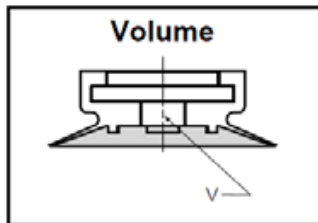

Model Number	Cup Diameter [mm]	Area [cm ²]	Cup Deflection [S] [mm]
PAG-10A-*	10	0,79	0,6
PAG-15A-*	15	1,77	0,9
PAG-20A-*	20	3,14	1,2
PAG-25-*	25	4,91	1,5
PAG-30-*	30	7,07	1,8
PAG-40-*	40	12,60	2,4
PAG-50-*	40	19,60	3,0

Millimeter
 * Cup Material

PAG Series Replacement Cup Dimensions

A

**PAG-10A and
 PAG-20A**

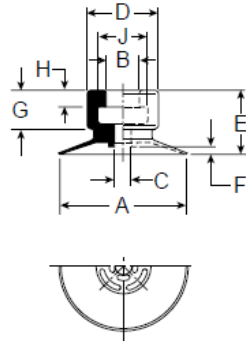

**PAG-25 thru
 PAG-50**

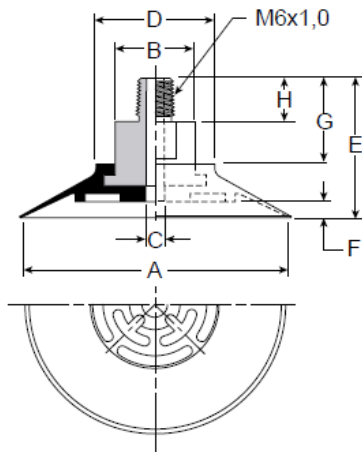

Model Number	ØA	ØB	ØC	ØD	E	F	G	H	J
PAG-10A-*	10	4	2	8,5	7,5	0,6	4	2	6
PAG-15A-*	15	4	2	8,5	7,5	0,9	4	2	6
PAG-20A-*	20	4	2	9	10	1,2	4	2	6
PAG-25-*	25	26	3	22	26	1,5	16	8	—
PAG-30-*	30	26	3	22	26	1,8	16	8	—
PAG-40-*	40	26	3	22	26	2,4	16	8	—
PAG-50-*	50	26	3	22	26	3	16	8	—

Millimeter
 * Cup Material

Dimensions

PATM-10A thru
 PATM-20A

A

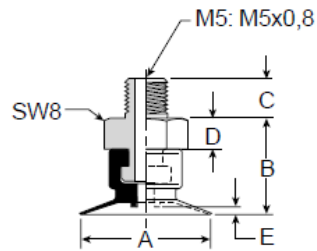

Model Number	ØA	B	C	D	E	F	G	H
PATM-10A-*†	10	11	4,5	3,5	0,6	—	—	—
PATM-15A-*†	15	11	4,5	3,5	0,9	—	—	—
PATM-20A-*†	20	13,5	4,5	3,5	1,2	—	—	—

Millimeter

* Cup Material

† Thread Size

A

Dimensions

PATK-10A thru
 PATK-20A

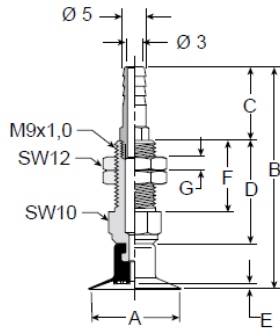

PATK-25 thru
 PATK-50

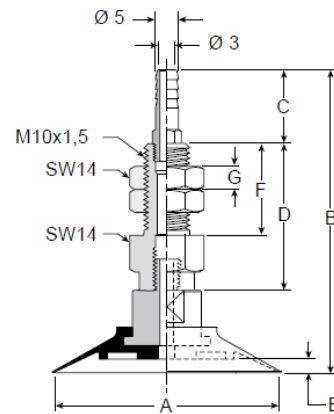

Model Number	ØA	B	C	D	E	F	G
PATK-10A-*	10	46	16	22,5	0,6	15,5	3
PATK-15A-*	15	46	16	22,5	0,9	15,5	3
PATK-20A-*	20	48,5	16	22,5	1,2	15,5	3
PATK-25-*	25	66,2	16	32,2	1,5	20	5
PATK-30-*	30	66,2	16	32,2	1,8	20	5
PATK-40-*	40	66,2	16	32,2	2,4	20	5
PATK-50-*	50	66,2	16	32,2	3	20	5

Millimeter

* Cup Material

Dimensions

PAYK-10A thru
 PAYK-20A

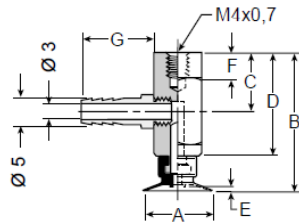

PAYK-25 thru
 PAYK-50

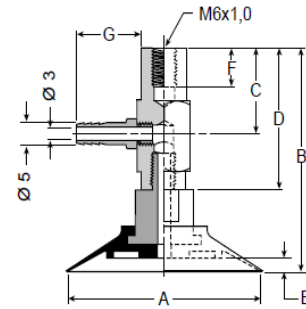

A

Model Number	ØA	B	C	D	E	F	G
PAYK-10A-*	10	30	13	22,5	0,6	6	16
PAYK-15A-*	15	30	13	22,5	0,9	6	16
PAYK-20A-*	20	32,4	20	22,5	1,2	6	16
PAYK-25-*	25	50	20	32	1,5	8	16
PAYK-30-*	30	50	20	32	1,8	8	16
PAYK-40-*	40	50	20	32	2,4	8	16
PAYK-50-*	50	50	20	32	3	8	16

Millimeter

* Cup Material

A

Features

- Double sealing lips for flexible sheet handling
- Vacuum cup grooves on underside increase holding area
- Resists acceleration and deceleration shear forces
- Strong low profile for fast response
- Metal insert fitting for stable vertical and horizontal lifts

Applications

These suction cups are ideal for applications where the product may flex when being lifted. All cups have a double sealing lip and cleats to increase holding capacity. The top of the cup has a ribbed outer lip to prevent it from rolling over the surface to be lifted.

Dual sealing lips provide 2 seals for vacuum. As the product flexes, the outer lip seal may break, but the inner lip seal will hold the degree of vacuum for continued lifting capacity. In these types of applications, sizing should be done on the inner diameter cup dimension.



Cup diameter (mm)	Vacuum port	Complete assembly Nitrile (NBR)	Area*** cm ²	Cup volume (V) liters	Deflection (S) (mm)	Radius R (mm)	
						R1*	R2**
50	1/8 BSPP	P5V-CFS05011N	19.6	.001	4	98	80
100	3/8 BSPP	P5V-CFS10013N	78.5	.0667	8	254	161
150	1/2 BSPP	P5V-CFS15014N	176.7	.2083	11	309	252

* Minimum permissible radius for lifting using inner lip.

** Minimum permissible radius for lifting using outer lip.

*** Area based on outer cup diameter

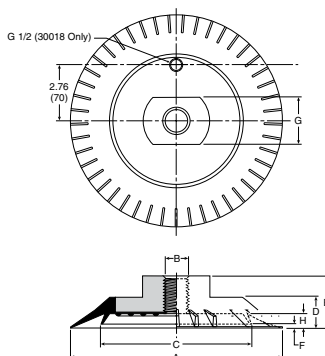
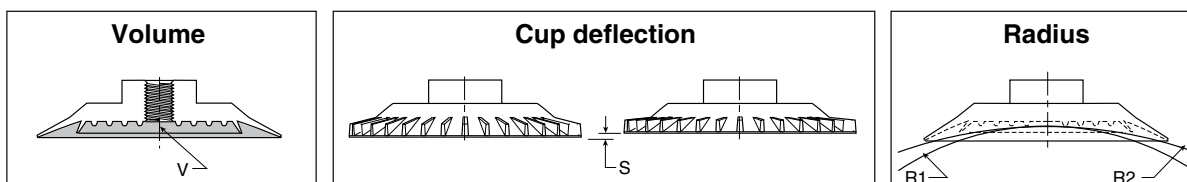

Dimensions (mm)

Model number	ØA	B	ØC	D	E	F	G	H
P5V-CFS50*	50	G1/8	35	11	18	2.2	13	3.7
P5V-CFS100*	100	G3/8	72	18	28	5	22	7.5
P5V-CFS150*	150	G1/2	106	26	42	7	27	11

* Cup material



Versatile bellow cup design provides increased sealing lip and level compensation for products with irregular, smooth, curved surfaces, or flexible sheets.

The short stroke bellow suction cup has an extra thin sealing edge and shorter stroke versus the traditional bellows for faster response. The cups are good for corrugated and smooth surfaces.

Features

- Short bellows for fast response
- More lip seal contact for corrugated, textured surfaces
- Soft sealing lip
- 6mm to 80mm



Styles

- PJTM series male thread connector
- PJTF series female thread connector
- PJTK series barbed bulkhead
- PJYK series 90° barbed adapter
- PJTYS series bulkhead level compensator

Specifications

Cup material	Nitrile	Nitrile ESD*	Silicon	Silicon ESD*
Material code	NBR	NBRE	SI	SIE
Operating temperature (°C)	-20° to +120°	-30° to +120°	-60° to +250°	-60° to +250°
Color	Black	Black / Blue Dot	White	Black / Red Dot
Hardness, shore A (°Sh)	55 ±5	70 ±5	55 ±5	55 ±5
Electrical resistance (Ωm)	—	800 to 1000	—	800 to 1000

* ESD: Electric Static Dissipative Material

How to order

Cups assemblies and replacement cups are specified by cup diameter and material. Standard nitrile and silicon are listed on the following pages. To specify an alternative material, replace the cup material with alternative cup material code.

Example: To specify a cup assembly with silicon ESD (SIE), replace (NBR) with (SIE) in the part number. PJTM-20B-NBR-G1 becomes PJTM-20B-SIE-G1. Inquire with factory for availability.

Application guide

Short Bellows

Flat surface, thin section	Flat surface, any section	Slightly bowed surface, thin section	Slightly bowed surface, any section	Bowed surface, thin section	Soft porous material, thin section	Soft porous material, any section	Metal sheet handling	Corrugated sheet handling	Not for vertical lift

A

PJTM Series Male Thread Connector

Simple male connection for low profile positions secured to a plate or bracket. BSPP, NPT metric threads.
 Fitting material: aluminum.

Installation

Note:
 When installing cup assemblies, use a sealant material to secure the assembly and prevent vacuum leakage.

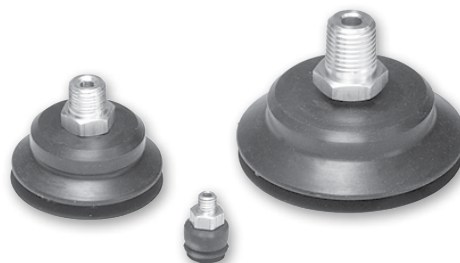
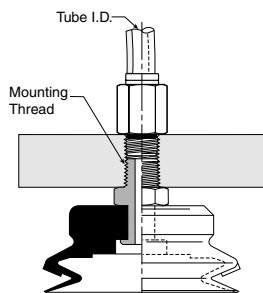

Cup diameter (mm)	Vacuum port	Complete assembly Nitrile	Replacement cup Nitrile (NB)	Complete assembly Silicon (SI)	Replacement cup Silicon (SI)	Replacement cup fitting
6	M5	PJTM-6-NBR-M5	PJG-6-NBR	PJTM-6-SI-M5	PJG-6-SI	FTM-5A-M5
6	1/8 BSPP	PJTM-6-NBR-G1	PJG-6-NBR	PJTM-6-SI-G1	PJG-6-SI	FTM-5A-G1
8	M5	PJTM-8-NBR-M5	PJG-8-NBR	PJTM-8-SI-M5	PJG-8-SI	FTM-5A-M5
8	1/8 BSPP	PJTM-8-NBR-G1	PJG-8-NBR	PJTM-8-SI-G1	PJG-8-SI	FTM-5A-G1
10	M5	PJTM-10-NBR-M5	PJG-10-NBR	PJTM-10-SI-M5	PJG-10-SI	TN-PF-15-M5
15	M5	PJTM-15-NBR-M5	PJG-15-NBR	PJTM-15-SI-M5	PJG-15-SI	TN-PF-15-M5
20	M5	PJTM-20-NBR-M5	PJG-20-NBR	PJTM-20-SI-M5	PJG-20-SI	TN-PF-20-M5
30	1/8 BSPP	PJTM-30-NBR-G1	PJG-30-NBR	PJTM-30-SI-G1	PJG-30-SI	FTM-20B-G1
30	1/4 BSPP	PJTM-30-NBR-G2	PJG-30-NBR	PJTM-30-SI-G2	PJG-30-SI	FTM-20B-G2
30	M10	PJTM-30-NBR-M10	PJG-30-NBR	PJTM-30-SI-M10	PJG-30-SI	FTM-20B-M10
30	1/8 NPT	PJTM-30-NBR-N1	PJG-30-NBR	PJTM-30-SI-N1	PJG-30-SI	FTM-20B-N1
40	1/8 BSPP	PJTM-40-NBR-G1	PJG-40-NBR	PJTM-40-SI-G1	PJG-40-SI	FTM-20B-G1
40	1/4 BSPP	PJTM-40-NBR-G2	PJG-40-NBR	PJTM-40-SI-G2	PJG-40-SI	FTM-20B-G2
40	M10	PJTM-40-NBR-M10	PJG-40-NBR	PJTM-40-SI-M10	PJG-40-SI	FTM-20B-M10
40	1/8 NPT	PJTM-40-NBR-N1	PJG-40-NBR	PJTM-40-SI-N1	PJG-40-SI	FTM-20B-N1
50	1/8 BSPP	PJTM-50-NBR-G1	PJG-50-NBR	PJTM-50-SI-G1	PJG-50-SI	FTM-50-G1
50	1/4 BSPP	PJTM-50-NBR-G2	PJG-50-NBR	PJTM-50-SI-G2	PJG-50-SI	FTM-50-G2
50	1/8 NPT	PJTM-50-NBR-N1	PJG-50-NBR	PJTM-50-SI-N1	PJG-50-SI	FTM-50-N1
60	1/4 BSPP	PJTM-60-NBR-G2	PJG-60-NBR	PJTM-60-SI-G2	PJG-60-SI	FTM-60-G2
60	M10	PJTM-60-NBR-M10	PJG-60-NBR	PJTM-60-SI-M10	PJG-60-SI	FTM-60-M10
60	1/4 NPT	PJTM-60-NBR-N2	PJG-60-NBR	PJTM-60-SI-N2	PJG-60-SI	FTM-60-N2
80	1/4 BSPP	PJTM-80-NBR-G2	PJG-80-NBR	PJTM-80-SI-G2	PJG-80-SI	FTM-60-G2
80	M10	PJTM-80-NBR-M10	PJG-80-NBR	PJTM-80-SI-M10	PJG-80-SI	FTM-60-M10
80	1/4 NPT	PJTM-80-NBR-N2	PJG-80-NBR	PJTM-80-SI-N2	PJG-80-SI	FTM-60-N2

PJTF Series Female Thread Connector

Simple female connection for low profile positions secured to a plate or bracket. BSPP, NPT metric threads.

Fitting material: aluminum.

Installation

Note:

When installing cup assemblies, use a sealant material to secure the assembly and prevent vacuum leakage.

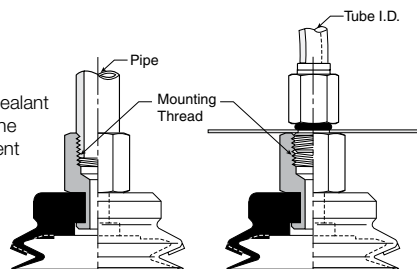

Cup diameter (mm)	Vacuum port	Complete assembly Nitrile	Replacement cup Nitrile (NB)	Complete assembly Silicon (SI)	Replacement cup Silicon (SI)	Replacement cup fitting
6	M5	PJTF-6-NBR-M5	PJG-6-NBR	PJTF-6-SI-M5	PJG-6-SI	FTF-5A-M5
6	1/8 BSPP	PJTF-6-NBR-G1	PJG-6-NBR	PJTF-6-SI-G1	PJG-6-SI	FTF-5A-G1
8	M5	PJTF-8-NBR-M5	PJG-8-NBR	PJTF--8-SI-M5	PJG-8-SI	FTF-5A-M5
8	1/8 BSPP	PJTF-8-NBR-G1	PJG-8-NBR	PJTF--8-SI-G1	PJG-8-SI	FTF-5A-G1
10	M5	PJTF-10-NBR-M5	PJG-10-NBR	PJTF-10-SI-M5	PJG-10-SI	FTF-5A-M5
10	1/8 BSPP	PJTF-10-NBR-G1	PJG-10-NBR	PJTF-10-SI-G1	PJG-10-SI	FTF-5A-G1
15	M5	PJTF-15-NBR-M5	PJG-15-NBR	PJTF-15-SI-M5	PJG-15-SI	FTF-5A-M5
15	1/8 BSPP	PJTF-15-NBR-G1	PJG-15-NBR	PJTF-15-SI-G1	PJG-15-SI	FTF-5A-G1
30	1/8 BSPP	PJTF-30-NBR-G1	PJG-30-NBR	PJTF-30-SI-G1	PJG-30-SI	FTF-20B-G1
30	1/4 BSPP	PJTF-30-NBR-G2	PJG-30-NBR	PJTF-30-SI-G2	PJG-30-SI	FTF-20B-G2
40	1/8 BSPP	PJTF-40-NBR-G1	PJG-40-NBR	PJTF-40-SI-G1	PJG-40-SI	FTF-20B-G1
40	1/4 BSPP	PJTF-40-NBR-G2	PJG-40-NBR	PJTF-40-SI-G2	PJG-40-SI	FTF-20B-G2
50	1/8 BSPP	PJTF-50-NBR-G1	PJG-50-NBR	PJTF-50-SI-G1	PJG-50-SI	FTF-50-G1
50	1/4 BSPP	PJTF-50-NBR-G2	PJG-50-NBR	PJTF-50-SI-G2	PJG-50-SI	FTF-50-G2
60	1/4 BSPP	PJTF-60-NBR-G2	PJG-60-NBR	PJTF-60-SI-G2	PJG-60-SI	FTF-60-G2
60	1/4 NPT	PJTF-60-NBR-N2	PJG-60-NBR	PJTF-60-SI-N2	PJG-60-SI	FTF-60-N2
80	1/4 BSPP	PJTF-80-NBR-G2	PJG-80-NBR	PJTF-80-SI-G2	PJG-80-SI	FTF-60-G2
80	1/4 NPT	PJTF-80-NBR-N2	PJG-80-NBR	PJTF-80-SI-N2	PJG-80-SI	FTF-60-N2

A

PJTK Series Barbed Bulkhead

Top stem connectors secured with jam nuts and allow tubing connections at the top side. Fitting material: nickel plated brass.

Installation

Note:
 When installing cup assemblies, use a sealant material to secure the assembly and prevent vacuum leakage.

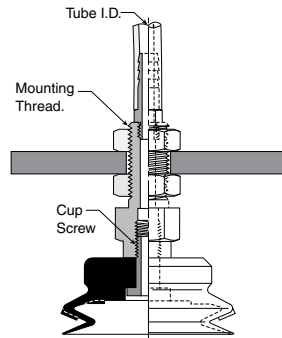

Cup diameter (mm)	Vacuum port	Complete assembly Nitrile	Replacement cup Nitrile (NB)	Complete assembly Silicon (SI)	Replacement cup Silicon (SI)	Replacement cup fitting
6	Barb	PJTK-6-NBR	PJG-6-NBR	PJTK-6-SI	PJG-6-SI	FTK-5A
8	Barb	PJTK-8-NBR	PJG-8-NBR	PJTK-8-SI	PJG-8-SI	FTK-5A
10	Barb	PJTK-10-NBR	PJG-10-NBR	PJTK-10-SI	PJG-10-SI	FTK-15
15	Barb	PJTK-15-NBR	PJG-15-NBR	PJTK-15-SI	PJG-15-SI	FTK-15
20	Barb	PJTK-20-NBR	PJG-20-NBR	PJTK-20-SI	PJG-20-SI	FTK-20
30	Barb	PJTK-30-NBR	PJG-30-NBR	PJTK-30-SI	PJG-30-SI	FTK-25
40	Barb	PJTK-40-NBR	PJG-40-NBR	PJTK-40-SI	PJG-40-SI	FTK-25
50	Barb	PJTK-50-NBR	PJG-50-NBR	PJTK-50-SI	PJG-50-SI	FTK-50
60	1/8 BSPP	PJTK-60-NBR-G1	PJG-60-NBR	PJTK-60-SI-G1	PJG-60-SI	FTK-60-G1
60	1/8 NPT	PJTK-60-NBR-N1	PJG-60-NBR	PJTK-60-SI-N1	PJG-60-SI	FTK-60-N1
80	1/8 BSPP	PJTK-80-NBR-G1	PJG-80-NBR	PJTK-80-SI-G1	PJG-80-SI	FTK-60-G1
80	1/8 NPT	PJTK-80-NBR-N1	PJG-80-NBR	PJTK-80-SI-N1	PJG-80-SI	FTK-60-N1

PJYK Series 90° Barbed Adapter

Side stem connectors allow you to secure the stem with a bolt through a plate or "L" bracket to allow the tube connection from the side port. Fitting material: nickel plated brass.

Installation

Note:

When installing cup assemblies, use a sealant material to secure the assembly and prevent vacuum leakage.

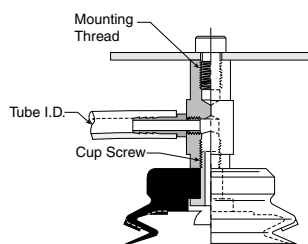

Cup diameter (mm)	Vacuum port	Complete assembly Nitrile	Replacement cup Nitrile (NB)	Complete assembly Silicon (SI)	Replacement cup Silicon (SI)	Replacement cup fitting
6	Barb	PJYK-6-NBR	PJG-6-NBR	PJYK-6-SI	PJG-6-SI	FYK-5A
8	Barb	PJYK-8-NBR	PJG-8-NBR	PJYK-8-SI	PJG-8-SI	FYK-5A
10	Barb	PJYK-10-NBR	PJG-10-NBR	PJYK-10-SI	PJG-10-SI	FYK-15
15	Barb	PJYK-15-NBR	PJG-15-NBR	PJYK-15-SI	PJG-15-SI	FYK-15
20	Barb	PJYK-20-NBR	PJG-20-NBR	PJYK-20-SI	PJG-20-SI	FYK-20
30	Barb	PJYK-30-NBR	PJG-30-NBR	PJYK-30-SI	PJG-30-SI	FYK-25
40	Barb	PJYK-40-NBR	PJG-40-NBR	PJYK-40-SI	PJG-40-SI	FYK-25
50	Barb	PJYK-50-NBR	PJG-50-NBR	PJYK-50-SI	PJG-50-SI	FYK-50
60	1/8 BSPP	PJYK-60-NBR-G1	PJG-60-NBR	PJYK-60-SI-G1	PJG-60-SI	FYK-60-G1
60	1/8 NPT	PJYK-60-NBR-N1	PJG-60-NBR	PJYK-60-SI-N1	PJG-60-SI	FYK-60-N1
80	1/8 BSPP	PJYK-80-NBR-G1	PJG-80-NBR	PJYK-80-SI-G1	PJG-80-SI	FYK-60-G1
80	1/8 NPT	PJYK-80-NBR-N1	PJG-80-NBR	PJYK-80-SI-N1	PJG-80-SI	FYK-60-N1

A

PJTYS Series Bulkhead Level Compensator

303 stainless steel construction secured with jam nuts. Spring biased compensators can absorb impacts of down-strokes and adjust for different levels of pick up points. 303 stainless corrosion resistant materials with drymet bushings increases the strength and life.

Installation

Note:

When installing cup assemblies, use a sealant material to secure the assembly and prevent vacuum leakage. Shown are interchangeable connectors & plugs for port connections.

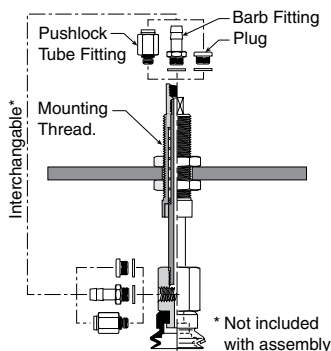

Cup dia. (mm)	Vacuum port	Stroke (mm)	Spring compression Force lbf (N)		Cup material Nitrile assembly (NBR)	Replacement cup Nitrile (NBR)	Cup material Silicon assembly (SI)	Replacement cup Silicon (SI)	Level Compensator P/N
			0%	100%					
10	M5	10	.56 (2.5)	1.2 (4.9)	PJTYS1010NBRM5	PJG-10-NBR	PJTYS1010SIM5	PJG-10-SI	JTYS-10-10-M5
10	M5	15	.67 (2.5)	1.4 (5.9)	PJTYS1015NBRM5	PJG-10-NBR	PJTYS1015SIM5	PJG-10-SI	JTYS-10-15-M5
15	M5	10	.56 (2.5)	1.2 (4.9)	PJTYS15A10NBRM5	PJG-15A-NBR	PJTYS15A10SIM5	PJG-15A-SI	JTYS-10-10-M5
15	M5	15	.67 (2.5)	1.4 (5.9)	PJTYS15A15NBRM5	PJG-15A-NBR	PJTYS15A15SIM5	PJG-15A-SI	JTYS-10-15-M5
30	M5	15	.56 (2.5)	.79 (3.4)	PJTYS3015NBRM5	PJG-30-NBR	PJTYS3015SIM5	PJG-30-SI	FTYS-20B-15-M5
30	M5	30	.67 (2.9)	1.4 (5.9)	PJTYS3030NBRM5	PJG-30-NBR	PJTYS3030SIM5	PJG-30-SI	FTYS-20B-30-M5
40	M5	15	.56 (2.5)	.79 (3.4)	PJTYS4015NBRM5	PJG-40-NBR	PJTYS4015SIM5	PJG-40-SI	FTYS-20B-15-M5
40	M5	30	.67 (2.9)	1.4 (5.9)	PJTYS4030NBRM5	PJG-40-NBR	PJTYS4030SIM5	PJG-40-SI	FTYS-20B-30-M5
50	M5	15	.56 (.25)	1.2 (4.9)	PJTYS5015NBRM5	PJG-50-NBR	PJTYS5015SIM5	PJG-50-SI	FTYS-50-15-M5
50	M5	30	.67 (2.9)	1.4 (5.9)	PJTYS5030NBRM5	PJG-50-NBR	PJTYS5030SIM5	PJG-50-SI	FTYS-50-30-M5
60	1/8 NPT	30	1.6 (6.8)	3.6 (15.6)	PJTYS6030NBRN1	PJG-60-NBR	PJTYS6030SIN1	PJG-60-SI	FTYS-60-30-G1
60	1/8 NPT	50	1.9 (8.3)	4.5 (19.6)	PJTYS6050NBRN1	PJG-60-NBR	PJTYS6050SIN1	PJG-60-SI	FTYS-60-50-G1
80	1/8 NPT	30	1.6 (6.8)	3.6 (15.6)	PJTYS8030NBRN1	PJG-80-NBR	PJTYS8030SIN1	PJG-80-SI	FTYS-60-30-G1
80	1/8 NPT	50	1.9 (8.3)	4.5 (19.6)	PJTYS8050NBRN1	PJG-80-NBR	PJTYS8050SIN1	PJG-80-SI	FTYS-60-50-G1

Applications

- High speed packaging
- Level compensation for small electronic components
- Flexible product
- Soft seal lip

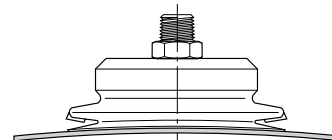
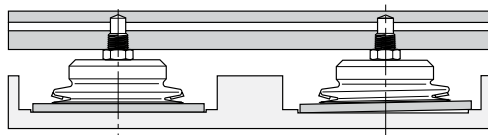
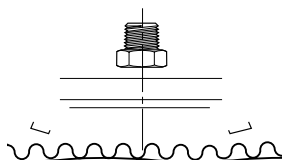

A

Main data for short bellows PJG cups

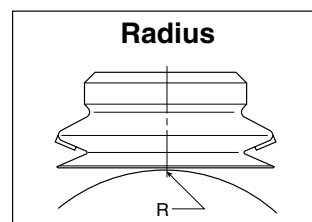
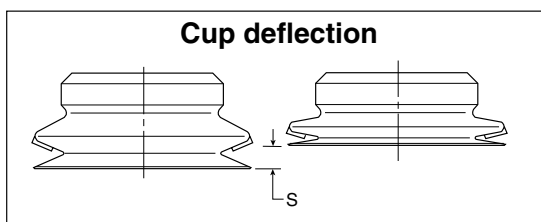
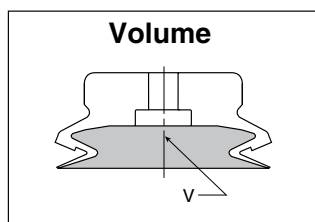

Model number	Cup diameter mm	Area cm ²	Volume (V) liters	Lifting force @ 60% (N)		Cup deflection (S) mm	Radius R mm
PJG-6-*	6	.28	0.000016	1.70	—	4.2	4.0
PJG-8-*	8	.50	0.00007	3.10	—	4.0	5.0
PJG-10-*	10	0.79	0.00017	4.80	—	3.0	6.0
PJG-15-*	15	1.77	0.0005	10.8	—	3.3	10.0
PJG-20-*	20	3.14	0.0012	19.2	—	5.5	13.0
PJG-30-*	30	7.07	0.003	43.2	—	7.0	26.0
PJG-40-*	40	12.6	0.005	76.9	—	7.2	37.0
PJG-50-*	50	19.6	0.008	120	—	9.0	41.0
PJG-60-*	60	28.3	0.020	173	—	8.0	70.0
PJG-80-*	80	50.3	0.040	308	—	9.5	100.0

*Cup material

A PJG Series Replacement Cup Dimensions

PJG-6 and PJG-8

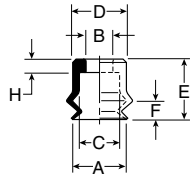

PJG-10 and PJG-15

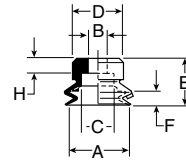

PJG-20

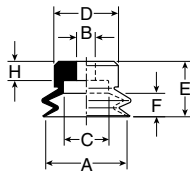

PJG-30 thru PJG-40

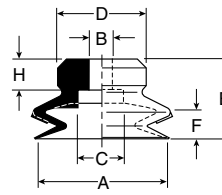

PJG-50

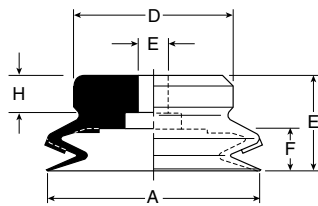

PJG-60 thru PJG-80

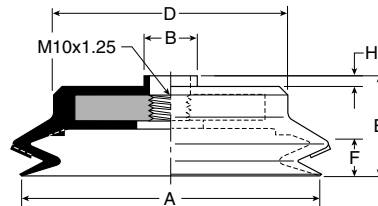

Dimensions (mm)

Model number	ØA	ØB	ØC	ØD	E	F	H
PJG-6-*	6	4	6	7.5	9	4.2	2
PJG-8-*	8	4	6	8	9	4	2
PJG-10-*	10	4.6	7.8	11	9.5	3	3.5
PJG-15-*	15	4.6	7.8	12	11	3.3	3.5
PJG-20-*	20	4.6	10.8	15	13	5.5	4.5
PJG-30-*	30	5.8	10.8	20	18	7	7
PJG-35-*	35	5.8	10.8	25	18	7	7
PJG-40-*	40	5.8	10.8	30	18	7.2	7
PJG-50-*	50	7.8	19.8	40	20	9	7
PJG-60-*	60	12.5	—	45	22.5	8	2.5
PJG-70-*	70	12.5	—	55	23.5	9.5	2.5
PJG-80-*	80	12.5	—	68	23.5	9.5	2.5

* Cup material



Dimensions

PJTM-6 and
PJTM-8

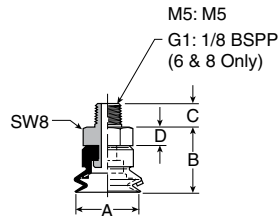

PJTM-10 thru
PJTM-20

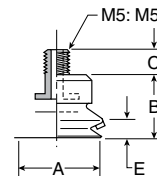

A

PJTM-30 thru
PJTM-50

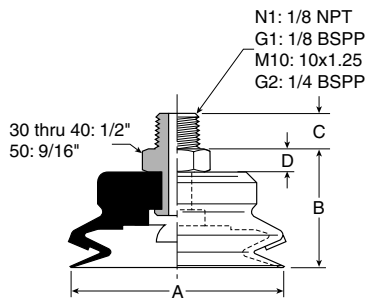

PJTM-60 thru
PJTM-80

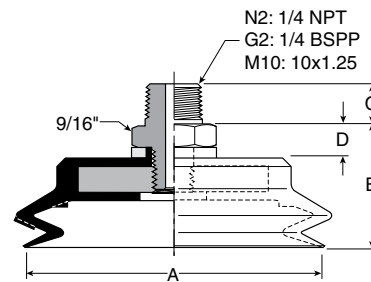

Dimensions (mm)

Model number	ØA	B	C (M5)	C (N1 / G1)	C (M10 / G2)	C (N2)	D
PJTM-6- [*] †	6	12.5	4.5	8	—	—	3.5
PJTM-8- [*] †	8	12.5	4.5	8	—	—	3.5
PJTM-10- [*] †	10	9.5	5	—	—	—	—
PJTM-15- [*] †	15	11	5	—	—	—	—
PJTM-20- [*] †	20	13	5	—	—	—	—
PJTM-30- [*] †	30	23	—	8	10	—	5
PJTM-40- [*] †	40	23	—	8	10	—	5
PJTM-50- [*] †	50	25	—	8	10	—	5
PJTM-60- [*] †	60	27	—	—	10	15	7
PJTM-80- [*] †	80	28	—	—	10	15	7

^{*} Cup material
[†] Thread size

A Dimensions

PJTF-6 and
PJTF-8

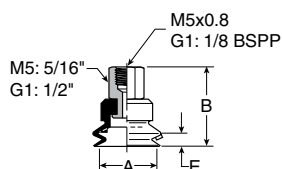

PJTF-30 thru
PJTF-50

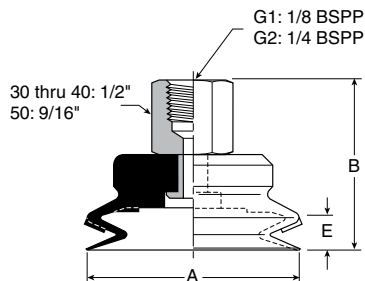

PJTF-60 thru
PJTF-80

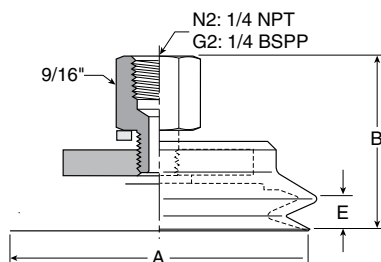

Dimensions (mm)

Model number	ØA	B	B (M5)	E
PJTF-6-*†	6	20	14	4
PJTF-8-*†	8	20	14	4
PJTF-10-*†	10	20	14	3
PJTF-15-*†	15	20	14	3.3
PJTF-30-*†	30	32	—	7
PJTF-40-*†	40	32	—	7.2
PJTF-50-*†	50	34	—	9
PJTF-60-*†	60	39.5	—	8
PJTF-80-*†	80	40.5	—	9.5

* Cup material
† Thread size

Dimensions

PJTK-6 and
PJTK-8

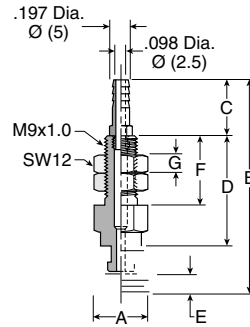

PJTK-10 thru
PJTK-20

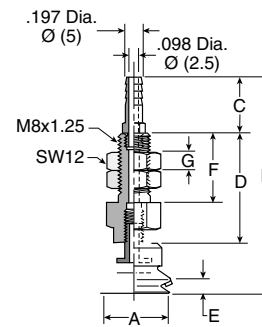

PJTK-30 thru
PJTK-50

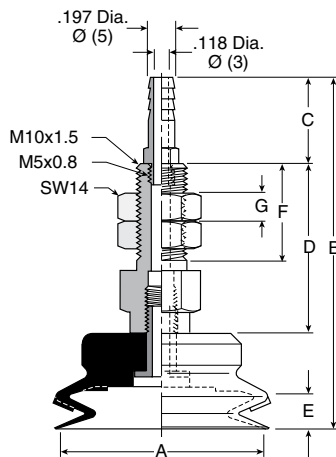

PJTK-60 thru
PJTK-80

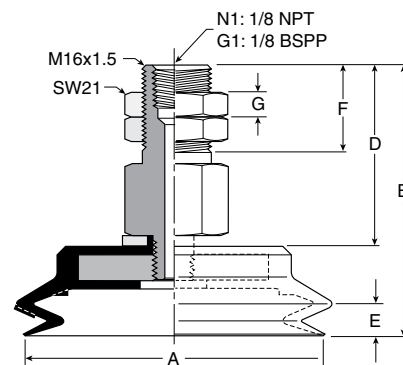

Dimensions (mm)

Model number	ØA	B	C	D	E	F	G	Wt g
PJTK-6-*	6	33	10	14	4.2	12	3	11
PJTK-8-*	8	33	10	14	4	12	3	11
PJTK-10-*	10	47.5	16	22	3	15	3	14
PJTK-15-*	15	49	16	22	3.3	15	3	15
PJTK-20-*	20	51	16	22	5.5	15	5	17
PJTK-30-*	30	66	16	32	7	20	5	42
PJTK-40-*	40	66	16	32	7.2	20	5	44
PJTK-50-*	50	68	16	32	9	20	5	58
PJTK-60-*-†	60	62.5	—	42.5	8	20	6	144
PJTK-80-*-†	80	63.5	—	42.5	9.5	20	6	190

* Cup material
† Vacuum port

A

Dimensions

PJK-6 and
PJK-8

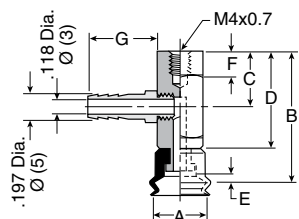

PJK-10 thru
PJK-20

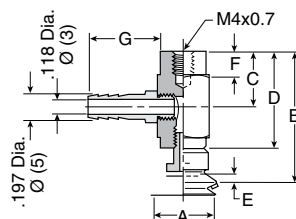

PJK-25 thru
PJK-50

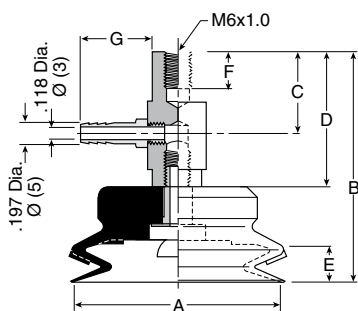

PJK-60 thru
PJK-80

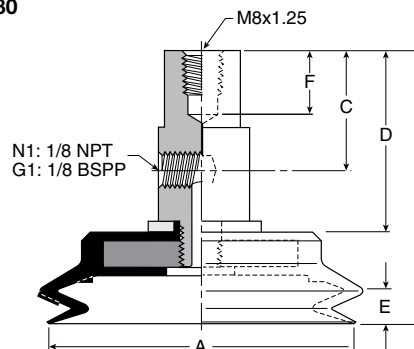

Dimensions (mm)

Model number	ØA	B	C	D	E	F	G	Wt g
PJK-6-*	6	31.5	13	22.5	4.2	6	16	16
PJK-8-*	8	31.5	13	22	4.2	6	16	16
PJK-10-*	10	31.5	14	22	3	6	16	17
PJK-15-*	15	33	14	22	3.3	6	16	18
PJK-20-*	20	35	14	22	5.5	6	16	20
PJK-30-*	30	50	20	32	7	8	16	46
PJK-40-*	40	50	20	32	7.2	8	16	48
PJK-50-*	50	52	20	32	9	8	16	62
PJK-60-*,†	60	62.5	28	42.5	8	11	—	139
PJK-80-*,†	80	63.5	28	42.5	9.5	11	—	185

* Cup material
† Vacuum port



Dimensions

PJTYS10 thru
PJTYS20

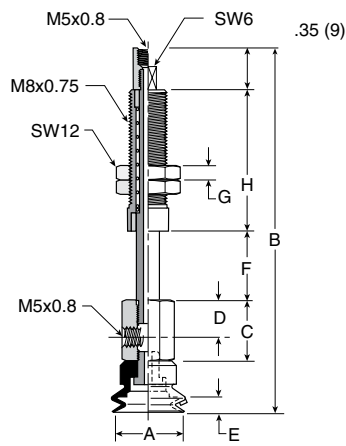

PJTYS30 thru
PJTYS50

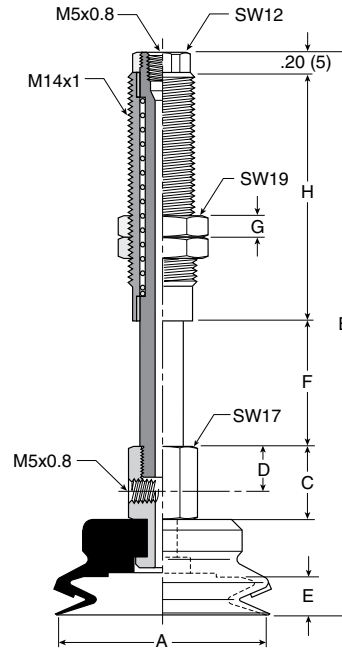

A

Dimensions (mm)

Model number	ØA	B	C	D	E	F	G	H	Wt g
PJTYS1010*†	10	64	13	8	3	10	5	23	31
PJTYS1015*†	10	76.5	13	8	3	15	5	30.5	33.5
PJTYS1510*†	15	66	13	8	3.3	10	5	23	32
PJTYS1515*†	15	78	13	8	3.3	15	5	30.5	34.5
PJTYS2010*†	20	72	13	8	5.5	10	5	23	32
PJTYS2015*†	20	109	13	8	5.5	15	5	30.5	34.5
PJTYS3015*†	30	91	17	10	7	15	5	36	74
PJTYS3030*†	30	128	17	10	7	30	5	58	99
PJTYS3515*†	35	91	17	10	7	15	5	36	76.5
PJTYS3530*†	35	128	17	10	7	30	5	58	101.5
PJTYS4015*†	40	91	17	10	7.2	15	5	36	78.5
PJTYS4030*†	40	128	17	10	7.2	30	5	58	103.5
PJTYS5015*†	50	93	17	10	9	15	5	36	94
PJTYS5030*†	50	130	17	10	9	30	5	58	119

** Cup material
† Vacuum port

A
Dimensions
PJTYS60 thru
PJTYS80

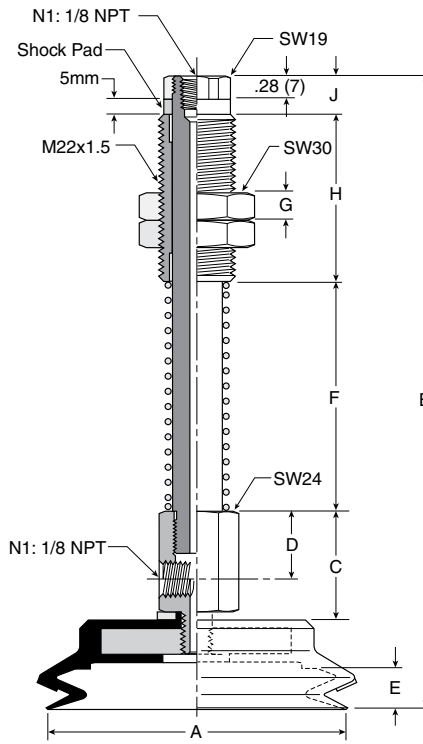

Dimensions (mm)

Model number	ØA	B	C	D	E	F	G	H	J	Wt g
PJTYS6030*†	60	157	30	20	8	45	10	50	12	294
PJTYS6050*†	60	182	30	20	8	70	10	50	12	328
PJTYS8030*†	80	158	30	20	9.5	45	10	50	12	338
PJTYS8050*†	80	183	30	20	9.5	70	10	50	12	372

** Cup material
† Vacuum port

2-1/2 bellows design minimizes contact pressure applied to the product. The soft seal lip and touch allows the cup to conform to the product's surface to make a vacuum seal.

These multiple bellow cups are designed for applications that require additional level compensation, more flexibility, or minimum back pressure for a "soft touch". The multiple bellow has a soft sealing edge good for a variety of sensitive applications; such as food packaging, CD / DVD, medical packaging, and highly irregular curved surfaces. Cups can also be used to assist with sheet separation in destack operations.



Features

- Soft touch
- Extra level compensation
- Flexible sealing lip for irregular curved surfaces
- 5mm to 90mm in diameter

Styles

- PCTM series male thread connector
- PCTF series female thread connector
- PCTK series barbed bulkhead

Specifications

Cup material	Nitrile	Nitrile ESD*	Silicon	Silicon ESD*	Urethane
Material code	NBR	NBRE	SI	SIE	U
Operating temperature (°C)	-20° to +120°	-30° to +120°	-60° to +250°	-60° to +250°	-30° to +120°
Color	Black	Black / Blue Dot	White	Black / Red Dot	Blue
Hardness, shore A (°Sh)	55 ±5	70 ±5	55 ±5	55 ±5	55 ±5
Electrical resistance (Ωm)	—	800 to 1000	—	800 to 1000	—

* ESD: Electric Static Dissipative Material

How to order

Cups assemblies and replacement cups are specified by cup diameter and material. Standard nitrile and silicon are listed on the following pages. To specify an alternative material, replace the cup material with alternative cup material code.

Example: To specify a cup assembly with urethane (U), replace (NBR) with (U) in the part number. PCTM-20B-NBR-G1 becomes PCTM-20B-U-G1. Inquire with factory for availability.

Application guide

2-1/2 Bellows

Flat surface, any section	Bowed surface, thin section	Slightly bowed surface, any section	Bowed surface, any section	Soft material	Metal sheet handling	Corrugated sheet handling	Differences in heights and levels	Not for vertical lift

A

PCTM Series Male Thread Connector

Simple male connection for low profile positions secured to a plate or bracket. BSPP, NPT, metric threads.
Fitting material: aluminum.

Installation

Note:
When installing cup assemblies, use a sealant material to secure the assembly and prevent vacuum leakage.

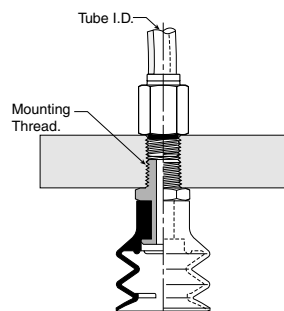

Cup diameter (mm)	Vacuum port	Complete assembly Nitrile (NBR)	Replacement cup Nitrile (NBR)	Complete assembly Silicon (SI)	Replacement cup Silicon (SI)	Replacement cup fitting
5	M5	PCTM-5-NBR-M5	PCG-5-NBR	PCTM-5-SI-M5	PCG-5-SI	FTM-5A-M5
7	M5	PCTM-7-NBR-M5	PCG-7-NBR	PCTM-7-SI-M5	PCG-7-SI	FTM-5A-M5
10	M5	PCTM-10-NBR-M5	PCG-10-NBR	PCTM-10-SI-M5	PCG-10-SI	CTM-10-M5
10	1/8 BSPP	PCTM-10-NBR-G1	PCG-10-NBR	PCTM-10-SI-G1	PCG-10-SI	CTM-10-G1
15	M5	PCTM-15-NBR-M5	PCG-15-NBR	PCTM-15-SI-M5	PCG-15-SI	CTM-10-M5
15	1/8 BSPP	PCTM-15-NBR-G1	PCG-15-NBR	PCTM-15-SI-G1	PCG-15-SI	CTM-10-G1
20	M5	PCTM-20-NBR-M5	PCG-20-NBR	PCTM-20-SI-M5	PCG-20-SI	CTM-10-M5
20	1/8 BSPP	PCTM-20-NBR-G1	PCG-20-NBR	PCTM-20-SI-G1	PCG-20-SI	CTM-10-G1
30	1/8 BSPP	PCTM-30-NBR-G1	PCG-30-NBR	PCTM-30-SI-G1	PCG-30-SI	CTM-30-G1
30	1/4 BSPP	PCTM-30-NBR-G2	PCG-30-NBR	PCTM-30-SI-G2	PCG-30-SI	CTM-30-G2
30	1/8 NPT	PCTM-30-NBR-N1	PCG-30-NBR	PCTM-30-SI-N1	PCG-30-SI	CTM-30-N1
40	1/8 BSPP	PCTM-40-NBR-G1	PCG-40-NBR	PCTM-40-SI-G1	PCG-40-SI	CTM-30-G1
40	1/4 BSPP	PCTM-40-NBR-G2	PCG-40-NBR	PCTM-40-SI-G2	PCG-40-SI	CTM-30-G2
40	1/8 NPT	PCTM-40-NBR-N1	PCG-40-NBR	PCTM-40-SI-N1	PCG-40-SI	CTM-30-N1
60	1/8 BSPP	PCTM-60-NBR-G1	PCG-60-NBR	PCTM-60-SI-G1	PCG-60-SI	CTM-30-G1
60	1/8 NPT	PCTM-60-NBR-N1	PCG-60-NBR	PCTM-60-SI-N1	PCG-60-SI	CTM-30-N1
90	1/4 BSPP	PCTM-90-NBR-G2	PCG-90-NBR	PCTM-90-SI-G2	PCG-90-SI	CTM-90-G2
90	1/4 NPT	PCTM-90-NBR-N2	PCG-90-NBR	PCTM-90-SI-N2	PCG-90-SI	CTM-90-N2

PCTF Series Female Thread Connector

Simple female connection for low profile positions secured to a plate or bracket. BSPP, NPT metric threads.

Fitting material: aluminum.

Installation

Note:
 When installing cup assemblies, use a sealant material to secure the assembly and prevent vacuum leakage.

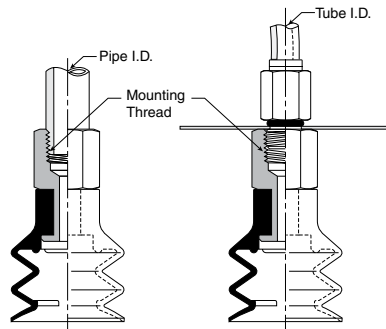

A

Cup diameter (mm)	Vacuum port	Complete assembly Nitrile (NBR)	Replacement cup Nitrile (NBR)	Complete assembly Silicon (SI)	Replacement cup Silicon (SI)	Replacement cup fitting
5	M5	PCTF-5-NBR-M5	PCG-5-NBR	PCTF-5-SI-M5	PCG-5-SI	FTF-5A-M5
7	M5	PCTF-7-NBR-M5	PCG-7-NBR	PCTF-7-SI-M5	PCG-7-SI	FTF-5A-M5
10	1/8 BSPP	PCTF-10-NBR-G1	PCG-10-NBR	PCTF-10-SI-G1	PCG-10-SI	CTF-10-G1
15	1/8 BSPP	PCTF-15-NBR-G1	PCG-15-NBR	PCTF-15-SI-G1	PCG-15-SI	CTF-10-G1
20	1/8 BSPP	PCTF-20-NBR-G1	PCG-20-NBR	PCTF-20-SI-G1	PCG-20-SI	CTF-10-G1
30	1/8 BSPP	PCTF-30-NBR-G1	PCG-30-NBR	PCTF-30-SI-G1	PCG-30-SI	CTF-30-G1
30	1/8 NPT	PCTF-30-NBR-N1	PCG-30-NBR	PCTF-30-SI-N1	PCG-30-SI	CTF-30-N1
40	1/8 BSPP	PCTF-40-NBR-G1	PCG-40-NBR	PCTF-40-SI-G1	PCG-40-SI	CTF-30-G1
40	1/8 NPT	PCTF-40-NBR-N1	PCG-40-NBR	PCTF-40-SI-N1	PCG-40-SI	CTF-30-N1
60	1/8 NPT	PCTF-60-NBR-N1	PCG-60-NBR	PCTF-60-SI-N1	PCG-60-SI	CTF-30-G1
60	1/4 NPT	PCTF-60-NBR-N1	PCG-60-NBR	PCTF-60-SI-N1	PCG-60-SI	CTF-30-N1
90	1/4 BSPP	PCTF-90-NBR-G2	PCG-90-NBR	PCTF-90-SI-G2	PCG-90-SI	CTF-90-G2
90	1/4 NPT	PCTF-90-NBR-N2	PCG-90-NBR	PCTF-90-SI-N2	PCG-90-SI	CTF-90-N2

A

PCTK Series Barbed Bulkhead

Top stem connectors secured with jam nuts and allow tubing connections at the top side. Fitting material: nickel plated brass.

Installation

Note:

When installing cup assemblies, use a sealant material to secure the assembly and prevent vacuum leakage.

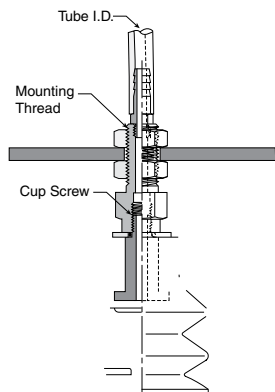

Cup diameter (mm)	Vacuum port	Complete assembly Nitrile (NBR)	Replacement cup Nitrile (NBR)	Complete assembly Silicon (SI)	Replacement cup Silicon (SI)	Replacement cup fitting
5	Barb	PCTK-5-NBR	PCG-5-NBR	PCTK-5-SI	PCG-5-SI	FTK-5A
7	Barb	PCTK-7-NBR	PCG-7-NBR	PCTK-7-SI	PCG-7-SI	FTK-5A
10	Barb	PCTK-10-NBR	PCG-10-NBR	PCTK-10-SI	PCG-10-SI	CTK-10
15	Barb	PCTK-15-NBR	PCG-15-NBR	PCTK-15-SI	PCG-15-SI	CTK-10
20	Barb	PCTK-20-NBR	PCG-20-NBR	PCTK-20-SI	PCG-20-SI	CTK-10
30	Barb	PCTK-30-NBR	PCG-30-NBR	PCTK-30-SI	PCG-30-SI	CTK-30
40	Barb	PCTK-40-NBR	PCG-40-NBR	PCTK-40-SI	PCG-40-SI	CTK-30
60	Barb	PCTK-60-NBR	PCG-60-NBR	PCTK-60-SI	PCG-60-SI	CTK-30
90	NPT	PCTK-90-NBR-N1	PCG-90-NBR	PCTK-90-SI-N1	PCG-90-SI	CTK-90-N1
90	BSPP	PCTK-90-NBR-G1	PCG-90-NBR	PCTK-90-SI-G1	PCG-90-SI	CTK-90-G1

Applications

- Destack perimeter separation
- Level compensation for applications where level compensators do not have adequate space
- Controlling downstroke lifts product on contact

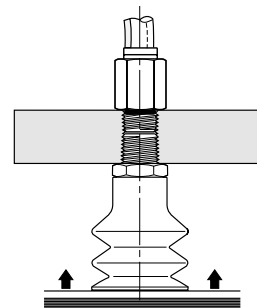
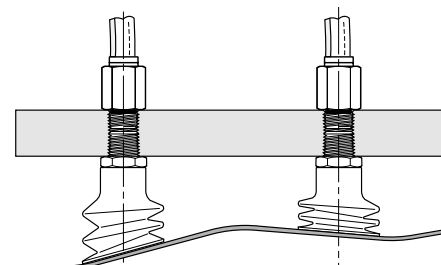
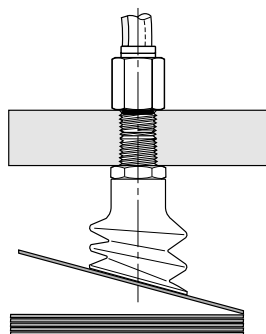

A

Main data for 2-1/2 bellows PCG cups

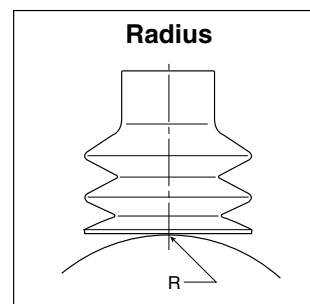
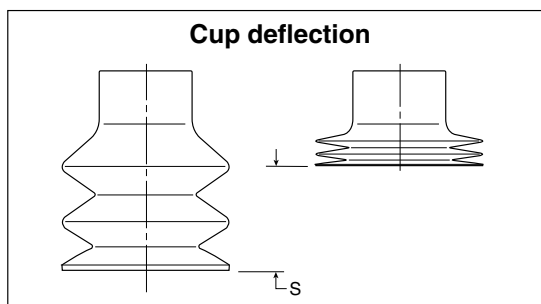
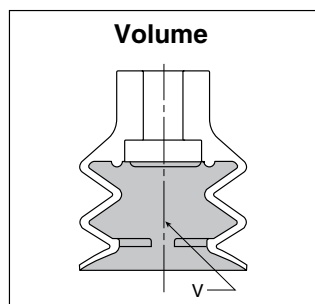

Model number	Cup diameter mm	Area cm ²	Volume (V) liters	Lifting force @ 60% (N)		Cup deflection (S) mm	Radius (R) mm
PCG-5-*	5	.20	.00003	1.20	—	3	3.5
PCG-7-*	7	.39	.00004	2.40	—	3	4.0
PCG-10-*	10	.79	.0001	4.80	—	3	5.0
PCG-15-*	15	1.77	.0009	10.8	—	10	6.0
PCG-20-*	20	3.14	.002	19.2	—	10	8.0
PCG-30-*	30	7.07	.009	43.2	—	14.5	20.0
PCG-40-*	40	12.6	.018	76.9	—	22	30.0
PCG-60-*	60	28.3	.072	173	—	27	55.0
PCG-90-*	90	63.6	.1639	389	—	42	80.0

* Cup material

A PCG Series Replacement Cup Dimensions

PCG-5 and
PCG-7

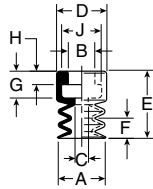

PCG-10 thru
PCG-20

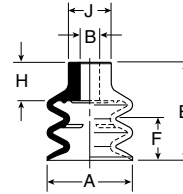

PCG-30 thru
PCG-60

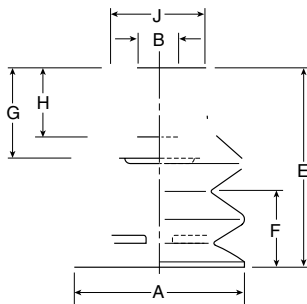

PCG-90

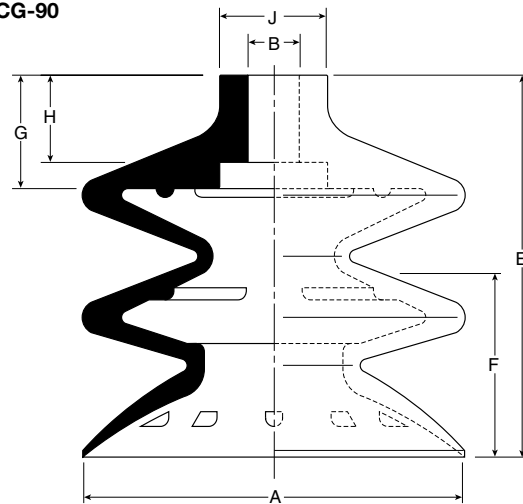

Dimensions (mm)

Model number	ØA	ØB	ØC	ØD	E	F	G	H	J
PCG-5-*	5	4	2	7.5	9.5	3	4	2	6
PCG-7-*	7	4	2	7.5	10	3	4	2	6
PCG-10-*	9	5	—	—	15	3	7	—	9
PCG-15-*	15.2	5	—	—	22	10	9	—	10
PCG-20-*	20	5	—	—	23	10	9	—	10
PCG-30-*	32	8	—	—	37.5	14.5	17	13	18
PCG-40-*	42	8	—	—	46	22	17	13	20
PCG-60-*	62	8	—	—	55	27	18	13	21.5
PCG-90-*	88	12	—	—	87.5	42	26	20	25

* Cup material



Dimensions

PCTM-5 and
PCTM-7

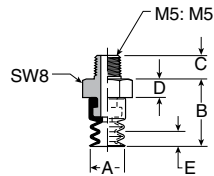

PCTM-10 thru
PCTM-20

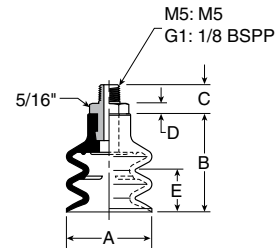

PCTM-30 thru
PCTM-60

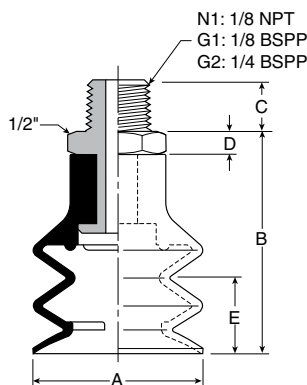

PCTM-90

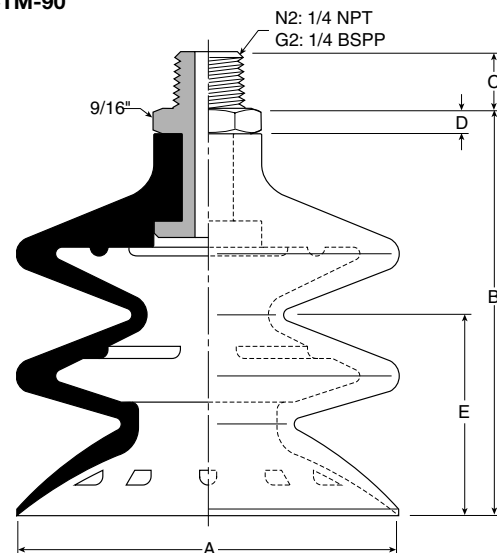

Dimensions (mm)

Model number	ØA	B	C (M5)	C (N1 / G1)	C M10 / G2)	C (N2)	D	E
PCTM-5-*.†	5	13	4.5	—	—	—	3.5	3
PCTM-7-*.†	7	13.5	4.5	—	—	—	3.5	3
PCTM-10-*.†	9	17.5	4.5	8	—	—	2.5	3
PCTM-15-*.†	15.2	25.5	4.5	8	—	—	2.5	10
PCTM-20-*.†	20	25.5	4.5	8	—	—	2.5	10
PCTM-30-*.†	32	42.5	—	8	10	—	5	14.5
PCTM-40-*.†	42	51	—	8	10	—	5	22
PCTM-60-*.†	62	60	—	8	10	—	5	27
PCTM-90-*.†	88	92.5	—	—	10	15	5	42

* Cup material
† Thread size

A

Dimensions

PCTF-5 and PCTF-7

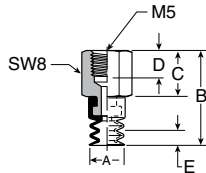

PCTF-10 thru PCTF-20

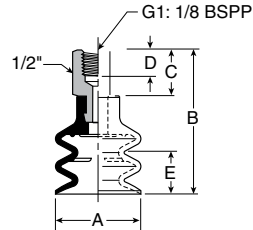

PCTF-30 thru PCTF-60

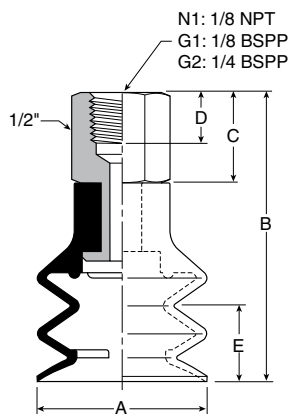

PCTF-90

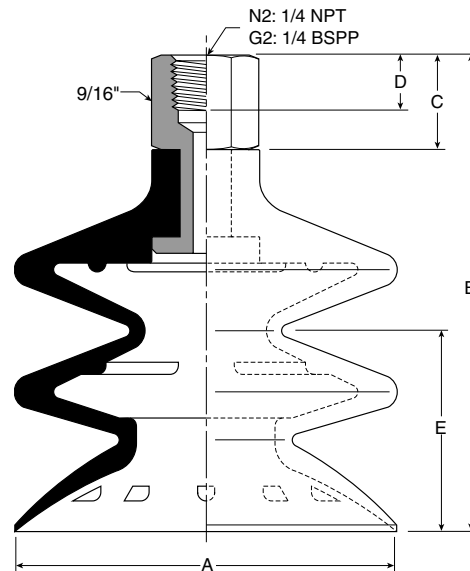

Dimensions (mm)

Model number	ØA	B	C	D	E
PCTF-5*†	5	21.5	12	8	3
PCTF-7*†	7	22	12	8	3
PCTF-10*†	9	27	12	8	3
PCTF-15*†	15.2	35	12	8	10
PCTF-20*†	20	35	12	8	10
PCTF-30*†	32	51.5	14	8	14.5
PCTF-40*†	42	60	14	8	22
PCTF-60*†	62	69	14	8	27
PCTF-90*†	88	105	17.5	10	42

* Cup material
† Thread size

Dimensions

PCTK-5 and
PCTK-7

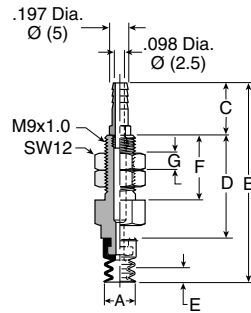

PCTK-10 thru
PCTK-20

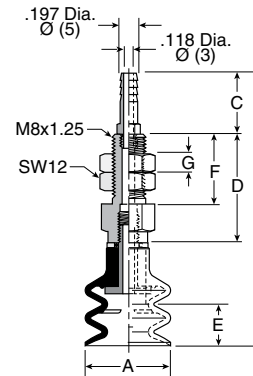

PCTK-30 thru
PCTK-60

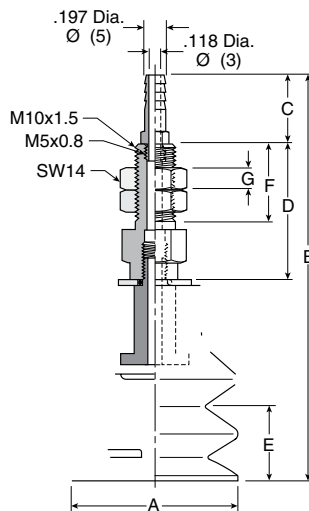

PCTK-90

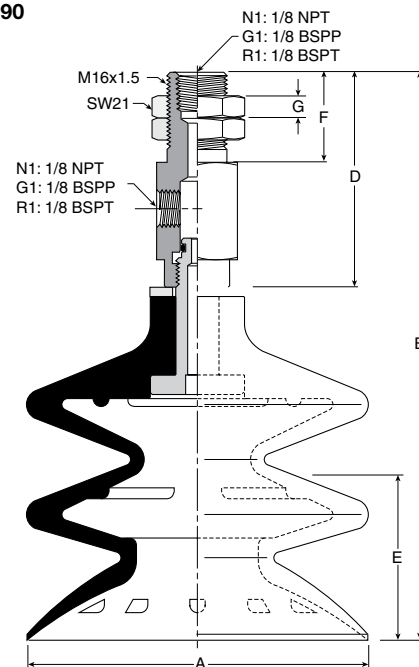

Dimensions (mm)

Model number	ØA	B	C	D	E	F	G	Wt g
PCTK-5*	5	33.5	10	14	3	12	3	11
PCTK-7*	7	34	10	14	3	12	3	11
PCTK-10*	9	56.2	16	22.5	3	15	4	22
PCTK-15*	15.2	64.2	16	22	10	15	4	22
PCTK-20*	20	64.2	16	(22)	10	15	4	22
PCTK-30*	32	86.8	16	32	14.5	20	5	46
PCTK-40*	42	95.3	16	32	22	20	5	55
PCTK-60*	62	104.3	16	32	27	20	5	85
PCYK-90*	88	144.8	23	55	42	11	—	300

* Cup material
† Vacuum port

A

30° inclusive swivel, single lip cup for smooth, slightly curved surfaces and flexible products. Rigid construction provides good stability against acceleration and deceleration forces during product transfer.

The single edge swivel cup is for smooth surfaces with slightly curved surfaces or flexible sheets with substantial weights. Typically, lift capacities and break away forces are higher for flat cups which may be necessary for good stability during lift and transfer. The position of the internal swivel joint minimizes moments during lift and transfer. The swivel joint compensates for load and angular misalignment instead of the cup material, prolonging cup life. Maintenance costs are minimized by replacing only the cup portion of the assembly.

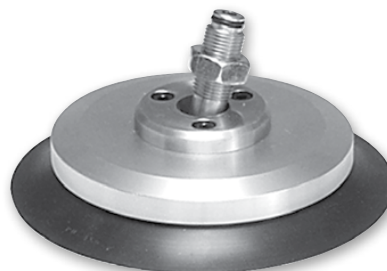

Features

- Internal swivel joint design
- 30° Inclusive angle for flexible products
- Increased stability for horizontal lifts
- Lower maintenance costs
- 60mm to 100mm diameters

Styles





- PUTYK series barbed bulkhead
- PUTYS series bulkhead level compensator

Specifications

Suction cup material	Nitrile (NBR)	Silicon (SI)
Operating temperature (°C)	-20° to +120°	-60° to +250°
Color	Black	White
Hardness, shore A (°Sh)	55 ±5	55 ±5

Application guide

Swivel Bellows

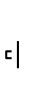
					
Flat surface, thin section	Flat surface, any section	Slightly bowed surface, thin section	Slightly bowed surface, any section	Metal sheet handling	Not for vertical lift

PUTYK Series Barbed Bulkhead

Top stem connectors secured with jam nuts and allow tubing connections at the top side. Fitting material: nickel plated brass.

Installation

Note:

When installing cup assemblies, use a sealant material to secure the assembly and prevent vacuum leakage.

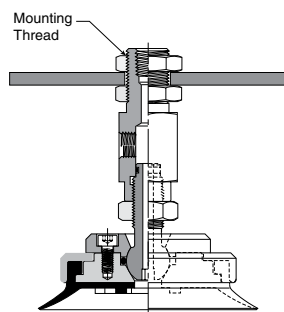

Cup size	Vacum port	Cup material Nitrile assembly (NBR)	Replacement PUGB swivel with cup only	Replacement cup only (NBR)	Cup fitting
60	1/8 BSPP	PUTYK-60-NBR-G1	PUGB-60-NBR	PUG-60-NBR	UTYK-60-G1
80	1/8 BSPP	PUTYK-80-NBR-G1	PUGB-80-NBR	PUG-80-NBR	UTYK-60-G1
100	1/8 BSPP	PUTYK-100-NBR-G1	PUGB-100-NBR	PUG-100-NBR	UTYK-60-G1

PUTYS Series Bulkhead Level Compensator

303 stainless steel construction secured with jam nuts. Spring biased compensators can absorb impacts of down-strokes and adjust for different levels of pick up points. 303 stainless corrosion resistant materials with drymet bushings increases the strength and life.

Installation

Note:

When installing cup assemblies, use a sealant material to secure the assembly and prevent vacuum leakage. Shown are interchangeable connectors & plugs for port connections.

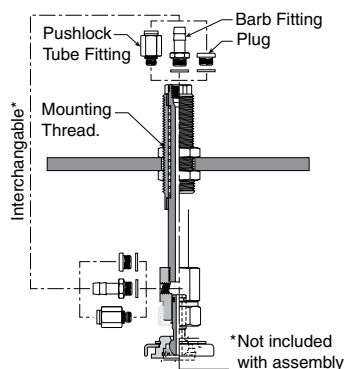

Cup diameter (mm)	Vacum port	Stroke (mm)	Spring compression Force lbf (N)		PUTYS assembly (NBR)	Replacement PUGB swivel with cup only	Replacement cup only NBR	Level compensator P/N
			0%	100%				
60	1/8 BSPP	30	1.6 (6.8)	3.6 (15.6)	PUTYS6030NBRG1	PUGB-60-NBR	PUG-60-NBR	UTYS-60-30-G1
60	1/8 BSPP	50	1.9 (8.3)	4.5 (19.6)	PUTYS6050NBRG1	PUGB-60-NBR	PUG-60-NBR	UTYS-60-50-G1
80	1/8 BSPP	30	1.6 (6.8)	3.6 (15.6)	PUTYS8030NBRG1	PUGB-80-NBR	PUG-80-NBR	UTYS-60-30-G1
80	1/8 BSPP	50	1.9 (8.3)	4.5 (19.6)	PUTYS8050NBRG1	PUGB-80-NBR	PUG-80-NBR	UTYS-60-50-G1
100	1/8 BSPP	30	1.6 (6.8)	3.6 (15.6)	PUTYS10030NBRG1	PUGB-100-NBR	PUG-100-NBR	UTYS-60-30-G1
100	1/8 BSPP	50	1.9 (8.3)	4.5 (19.6)	PUTYS10050NBRG1	PUGB-100-NBR	PUG-100-NBR	UTYS-60-50-G1

A

Applications

- Angles pickup

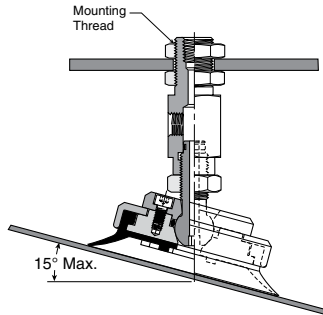

- Fixtures for curved product

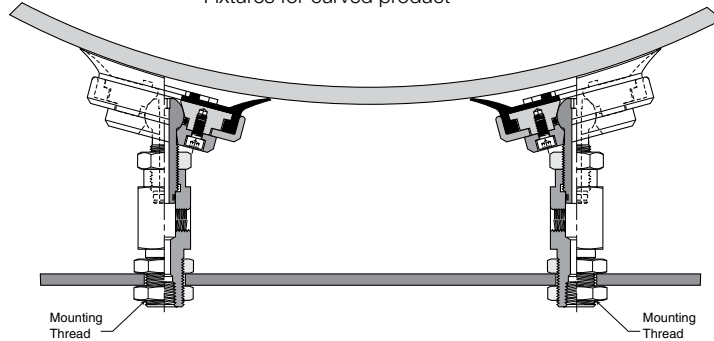

Main data for swivel bellows PUG cups

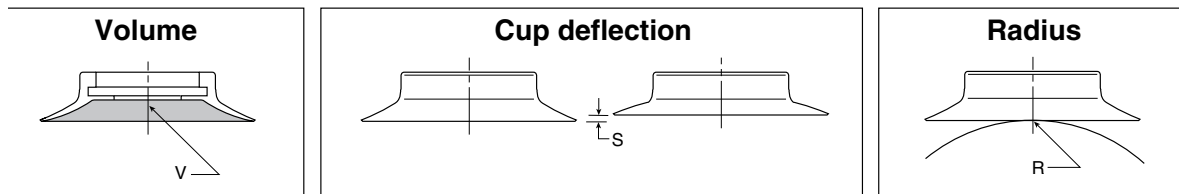

Model number	Cup diameter mm	Area cm ²	Volume (V) liters	Lifting force @ 60% (N)		Cup deflection (S) mm	Radius R (mm)
PUGB-60-*	60	28.3	0.0090	173	—	5	70
PUGB-80-*	80	50.3	0.025	308	—	6	100
PUGB-100-*	100	78.5	0.045	480	—	6	150

* Cup material

PUGB Series Barbed Bulkhead Dimensions

PUGB-60 thru
PUGB-100

A

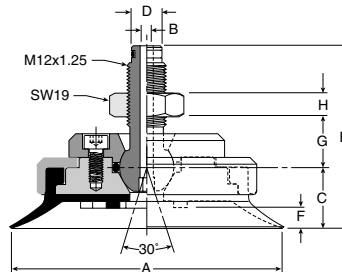

Dimensions (mm)

Model number	ØA	ØB	C	ØD	E	F	G	H
PUGB-60-*	60	3.9	16	9	52	5	15	7
PUGB-80-*	80	3.9	18	9	54	6	15	7
PUGB-100-*	100	3.9	18	9	54	6	15	7

* Cup material

PUTYK Series Barbed Bulkhead Dimensions

PUTYK-60 thru
PUTYK-100

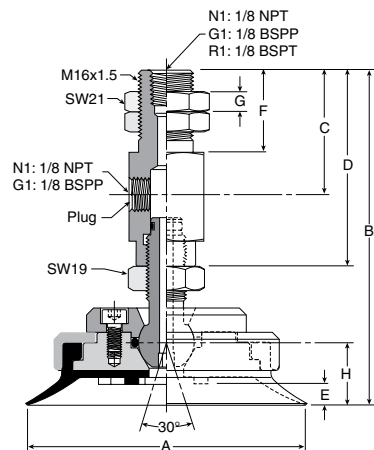

Dimensions (mm)

Model number	ØA	B	C	D	E	F	G	H	Wt g
PUTYK-60-*	60	93	16	48	5	23	6	16	352
PUTYK-80-*	80	95	35	55	6	23	6	18	444
PUTYK-100-*	100	95	35	55	6	23	6	18	568

* Cup material



Dimensions

A

PUTYS60 thru
PUTYS100

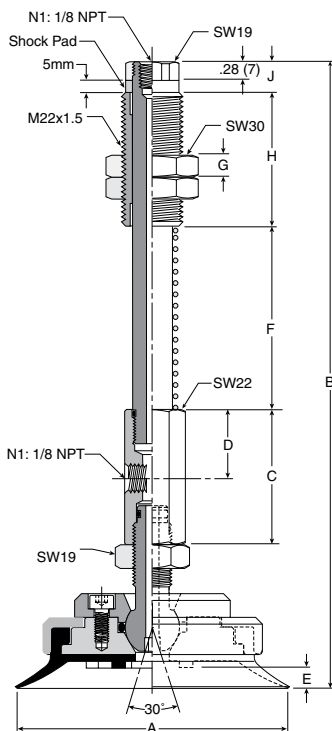

Dimensions (mm)

Model number	ØA	B	C	D	E	F	G	H	J	Wt g
PUTYS6030*	60	185	40	20	5	45	10	50	12	487
PUTYS6050*	60	210	40	20	5	70	10	50	12	521
PUTYS8030*	80	187	40	20	6	45	10	50	12	559
PUTYS8050*	80	212	40	20	6	70	10	50	12	595
PUTYS10030*	30	187	40	20	6	45	10	50	12	729
PUTYS10050*	30	212	40	20	6	70	10	50	12	756

* Cup material

Cup screws

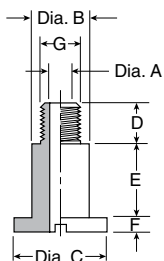

Dimensions (mm)

Part number	A	B	C	D	E	F	G
TN-PF-15-M5	2.5	5	8	5.5	1.5	2	M5
TN-PF-20-M5	2.5	5	11	6	3	2	M5
TN-PF-25-M6	3.5	8.5	14	6	11	2	M6
TN-PF-50-M6	3.5	8	20	6	6	2	M6
TN-PF-50-M8	4	8	20	10	5	2	M8
TN-PF-10-M5	2.5	3	6	5.5	2	2	M5
TN-PF-30-M6	3.4	8	15	10.5	10.5	3	M6
TN-PC-30-M8	3.9	8	15	12	10	3	M8
TN-PC-90-M12	3.9	12	25	11	19	5	M12

A

Male threaded cup fittings



Cup fitting	Cup series	Cup assembly	Vacuum port
FTM-5A-M5	PFG / PBG / PJG / PCG	PFTM / PBTM / PJTM / PCTM	M5
FTM-5A-G1	PFG / PBG / PJG / PCG	PFTM / PBTM / PJTM / PCTM	1/8 BSPP
FTM-20B-G1	PFG / PBG / PJG	PFTM / PBTM / PJTM	1/8 BSPP
FTM-20B-G2	PFG / PBG / PJG	PFTM / PBTM / PJTM	1/8 BSPP
FTM-20B-N1	PFG / PBG / PJG	PFTM / PBTM / PJTM	1/8 NPT
FTM-20B-M10	PFG / PBG / PJG	PFTM / PBTM / PJTM	M10
FTM-50-G1	PFG / PBG / PJG	PFTM / PBTM / PJTM	1/8 BSPP
FTM-50-N1	PFG / PBG / PJG	PFTM / PBTM / PJTM	1/8 NPT
FTM-50-G2	PFG / PBG / PJG	PFTM / PBTM / PJTM	1/8 BSPP
FTM-60-G2	PFG / PBG / PJG	PFTM / PBTM / PJTM	1/8 BSPP
FTM-60-N2	PFG / PBG / PJG	PFTM / PBTM / PJTM	1/4 NPT
FTM-60-M10	PFG / PBG / PJG	PFTM / PBTM / PJTM	M10
CTM-10-M5	PCG	PCTM	M5
CTM-10-G1	PCG	PCTM	1/8 BSPP
CTM-10-N1	PCG	PCTM	1/8 NPT

A

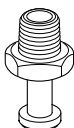
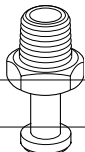
Male threaded cup fittings

Cup fitting	Cup series	Cup assembly	Vacuum port	
	CTM-30-G1	PCG	PCTM	1/8 BSPP
	CTM-30-N1	PCG	PCTM	1/8 NPT
	CTM-30-G2	PCG	PCTM	1/8 BSPP
	CTM-90-G2	PCG	PCTM	1/8 BSPP
	CTM-90-N2	PCG	PCTM	1/4 NPT

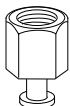
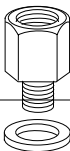
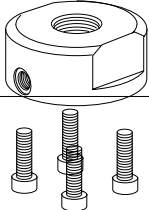
Female threaded cup fittings





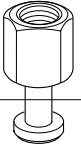
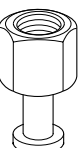

Cup fitting	Cup series	Cup assembly	Vacuum port	
	FTF-5A-M5	PFG / PBG / PJG	PFTF / PBTF / PJTF	M5
	FTF-5A-G1	PFG / PBG / PJG	PFTF / PBTF / PJTF	1/8 BSPP
	FTF-20B-G1	PFG / PBG / PJG	PFTF / PBTF / PJTF	1/8 BSPP
	FTF-20B-G2	PFG / PBG / PJG	PFTF / PBTF / PJTF	1/4 BSPP
	FTF-50-G1	PFG / PBG / PJG	PFTF / PBTF / PJTF	1/8 BSPP
	FTF-50-G2	PFG / PBG / PJG	PFTF / PBTF / PJTF	1/4 BSPP
	FTF-60-G2	PFG / PBG / PJG	PFTF / PBTF / PJTF	1/4 BSPP
	FTF-60-N2	PFG / PBG / PJG	PFTF / PBTF / PJTF	1/4 NPT
	FTF-120-G4	PFG / PBG	PFTF / PBTF	1/2 BSPP
	FTF-120-N4	PFG / PBG	PFTF / PBTF	1/2 NPT
		CTF-10-G1	PCG	PCTF

Female threaded cup fittings

	Cup fitting	Cup series	Cup assembly	Vacuum port
	CTF-30-G1	PCG	PCTF	1/8 BSPP
	CTF-30-N1	PCG	PCTF	1/8 NPT
	CTF-90-G2	PCG	PCTF	1/4 BSPP
	CTF-90-N2	PCG	PCTF	1/4 NPT

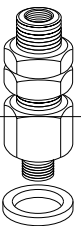
A

Bulkhead cup fittings

	Cup fitting	Cup series	Cup assembly	Vacuum port
	FTK-5A	PFG / PBG / PJG / PCG / PAG	PFTK / PBTK / PJTK / PCTK / PATK	Barb Fitting
	FTK-15	PFG / PBG / PJG	PFTK / PBTK / PJTK	Barb Fitting
	FTK-20	PFG / PFOG / PBG / PJG	PFTK / PBTK / PJTK	Barb Fitting
	FTK-25	PFG / PFOG / PBG / PJG	PFTK / PBTK / PJTK	Barb Fitting
	FTK-50	PFG / PBG / PJG	PFTK / PBTK / PJTK	Barb Fitting
	FTK-60-G1	PFG / PBG / PJG	PFTK / PBTK / PJTK	1/8 BSPP
	FTK-60-N1	PFG / PBG / PJG	PFTK / PBTK / PJTK	1/8 NPT
	CTK-10	PCG	PCTK	Barb Fitting
		PCG	PCTK	Barb Fitting
	UTYK-20	PUGB	PUTYK	Barb Fitting
	UTYK-40			

A

Bulkhead cup fittings

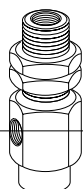

Cup fitting	Cup series	Cup assembly	Vacuum port
UTYK-60-G1	PUGB	PUTYK	1/8 BSPP
UTYK-60-R1	PUGB	PUTYK	1/8 BSPT
UTYK-60-N1	PUGB	PUTYK	1/8 NPT

90° cup fittings

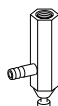

Cup fitting	Cup series	Cup assembly	Vacuum port
FYK-5A	PFG / PBG / PJG / PCG	PFYK / PBYK / PJYK / PCYK	Barb Fitting

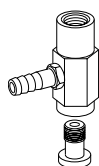

FYK-15	PFG / PBG / PJG	PFYK / PBYK / PJYK	Barb Fitting
FYK-20	PFG / PBG / PJG	PFYK / PBYK / PJYK	
FYK-25	PFG / PBG / PJG	PFYK / PBYK / PJYK	
FYK-50	PFG / PBG / PJG	PFYK / PBYK / PJYK	

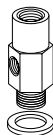

FYK-60-G1	PFG / PBG / PJG	PFYK / PBYK / PJYK	1/8 BSPP
FYK-60-N1	PFG / PBG / PJG	PFYK / PBYK / PJYK	1/8 NPT

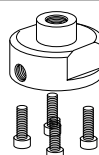

FYK-120-G1	PFG / PBG	PFYK / PBYK	1/8 BSPP
FYK-120-N1	PFG / PBG	PFYK / PBYK	1/8 NPT

Level compensators



Assembly part number	Cup series	Cup assembly	Compensator only	Cup fitting
FTYS-2A-3-M3	PFG / PBG / PJG	PFTYS / PBTYS / PJTYS	TYS-M5-3-M5	FTY-2A-M5-M3
FTYS-2A-15-M3			TYS-M5-15-M5	
FTYS-5A-10-M5	PFG / PBG	PFTYS / PBTYS	TYS-M5-10-M5	FTY-5A-M5-M5
FTYS-5A-15-M5			TYS-M5-15-M5	
FTYS-20B-15-M5	PFG / PBG / PJG	PFTYS / PBTYS / PJTYS	TYS-M8-15-M5	FTY-20B-M8-M5
FTYS-20B-30-M5			TYS-M8-30-M5	
FTYS-50-15-M5	PFG / PBG / PJG	PFTYS / PBTYS / PJTYS	TYS-M8-15-M5	FTY-50
FTYS-50-30-M5			TYS-M8-30-M5	

Level compensators

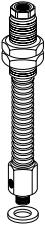
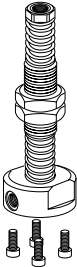
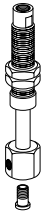
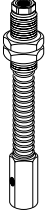
	Assembly part number	Cup series	Cup assembly	Compensator only	Cup fitting
	FTYS-60-30-G1			TYS-M14-25-G1	
	—————	PFG / PBG / PJG	PFTYS / PBTYS / PJTYS	—————	FTY-60/95
	FTYS-60-50-G1			TYS-M14-45-G1	
	FTYS-120-20-G2	PFG / PBG	PFTYS / PBTYS	TYS110/200M1820	FTY-120-N2
	FTYS-120-50-G2	PFG / PBG	PFTYS / PBTYS	TYS110/200M1870	FTY-120-N2
	JTYS-10-10-M5			NAPJYS-10-10-K	
	—————	PJG	PJTYS	—————	TN-PF-15-M5
	JTYS-10-15-M5			NAPJYS-10-15-K	
	UTYS-60-30-G1			TYS-M14-25-N	
	—————	PUGB	PUTYS	—————	UTY-60-M14-N1
	UTYS-60-50-G1			TYS-M14-45-N	

A

PDE2654TCUK
Vacuum Products

A



Vacuum Generators

Section B

www.parker.com/pneu/vacgen

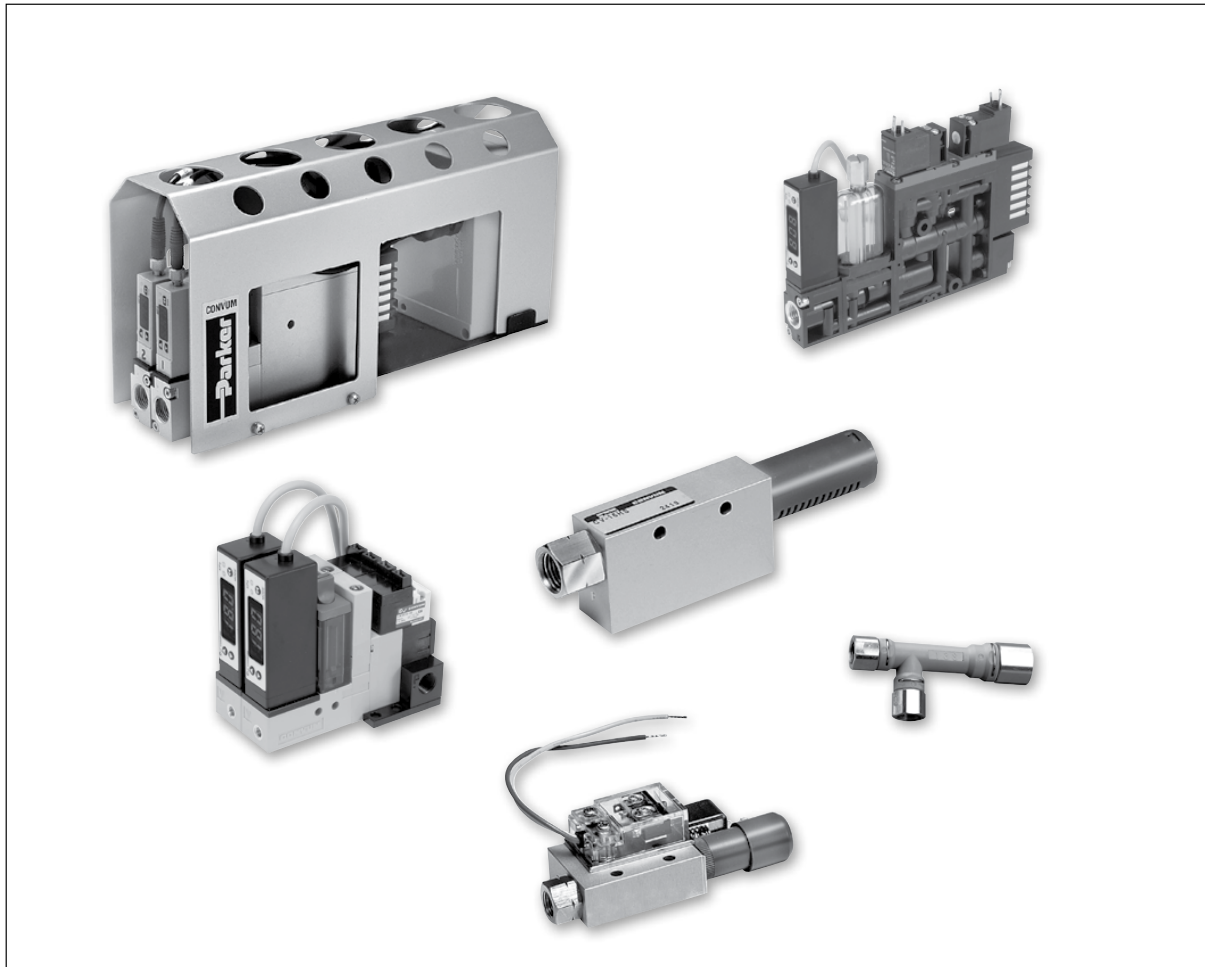

PDE2654TCUK
Vacuum Products

B

Generator Selection **How to Select a Generator** **B4 - B9**

Inline Vacuum Generators: Single Stage

MCA, CV, CV-CK



MCA is lightweight generator that can be located directly on the cup fitting for space savings. Great for use with TYS level compensators.
CV is a basic Venturi Generator with aluminum basic body. Includes exhaust muffler.
CV-CK is a Venturi Generator with adjustable open contact mechanical switch for vacuum confirmation. Great for low cost vacuum confirmation.
Additional Pneumatic Control Valve is required to create vacuum flow with these products.

B10 - B11

Integrated Vacuum Generators

MC22



The MC22 has integrated vacuum generating and blow-off release pilot valves to minimize the response time to achieve vacuum. The small foot print and lightweight body allows the unit to be located close to the suction cup for maximum performance. The MC22 has additional features; regulating blow-off needle, 37 micron mesh filter, The MC22 can be assembled into a maximum 8 station manifold. The unit can be ordered normally open or normally closed and with or without. Integrated check valves offer air economizing options with the MPS-23 and MVS-201 pressure sensors.

B12 - B17

MC72

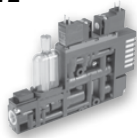

The MC72 is perfect for non-porous applications such as material handling, critical applications involving glass, or general transfer applications. The MC72 has integrated vacuum pilot and blow-off release pilot valves to minimize response times. The MC72 has additional features; regulating blow-off needle, 130 micron filter, optional check valve. The MC72 can be assembled into a maximum 5 station manifold. The unit can be ordered normally open or normally closed. Integrated check valves offer air economizing options with the MPS-23 and MVS-201 pressure sensors.

B18 - B23

CEK

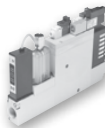

CEK Venturi Generator is a basic vacuum blow off integrated generator with the addition of a memory valve that maintains the last state of air during an emergency stop or power loss. The CEK Generator integrated components include valves for vacuum, air economizing, and blow-off functions, blow-off flow regulating valve, vacuum filters and a vacuum check valve. Optional pressure sensors reduce cycle time and can be used for air economizing to conserve air during part transfer. Inline versions can be mounted in manifolds up to 5 stations.

B24 - B29

CVXCEK



CVXCEK Venturi Generator is a basic 2 station CEK Generator Manifold with the addition of Emergency Stop Functions that maintains the last state of air during an emergency stop or power loss. This unit can be used for high-speed pick and place and material handling systems. CVXCEK Generator integrated components include valves for vacuum and blow-off functions, blow-off flow regulating valve, exhaust, vacuum filters and an optional vacuum check valve. Air economizing can be utilized with the vacuum check valve to conserve air during part transfer. No additional PLC programming is required for Air Economizing Functions because this function is built into the electrical unit.

B30 - B37

Generator Mount Sensors

MPS23



-101.3 - 0 kPa
-14.5 to 0 PSI

(2) NPN / PNP Air,
Non-corrosive
gas

IP40

Variable,
100% F.S.

Push
button

LED display
(Red)

B38 - B41

MVS201



0 to -30 inHg
-14.7 to 72.5 PSI

(1) NPN / PNP Air,
Non-corrosive
gas

IP40

Variable,
100% F.S.

Push
button

LED display
(Red)

B42 - B47

Generator Accessories

Filters, Check Valves, Silencers

B48 - B55

Glossary

B56 - B57

B

Principle of venturi vacuum

A vacuum generator is a single stage venturi that creates high vacuum with fast response using compressed air.

The ability to control this performance renders this technology as an excellent solution for factory automation.

In principle, compressed air is throttled as the air exits the nozzle and is discharged into the diffuser. This increased velocity of air lowers the pressure in the diffusion chamber. The volume of air within the closed vacuum system flows into the low pressure area of the diffusion chamber and is exhausted thru the diffuser. This effect increases the vacuum level and evacuates most of the air within the closed vacuum system at supersonic speeds.

B

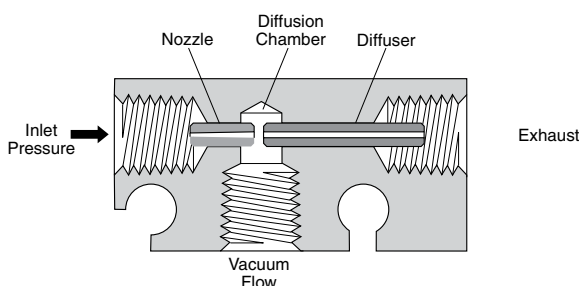

Additional advantages to venturi generators

- No moving components
- Low maintenance
- Long life
- Responsive
- Physically small
- Cost effective

Applying the venturi generator

1. Design a system with basic venturi generators and individual components to support the vacuum circuit.

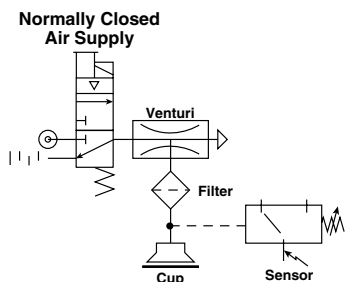

2. Design a system with all of the supporting components integrated into the venturi generator.

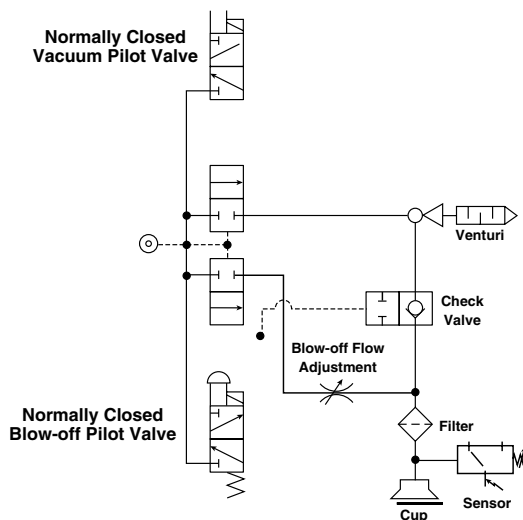

There are several advantages to an integrated venturi system. The response time of the vacuum and blow-off functions are greatly reduced compared to basic venturi generators, the installation time is also reduced which makes this a cost effective system and the compact size allows the integrated unit to be close to the suction cup.

Venturi generator with power loss circuits

When designing a vacuum system that requires a Normally Open circuit or Emergency Stop circuits to avoid any hazard during a power failure, consider the circuits below and on the following page.

Normally open circuit

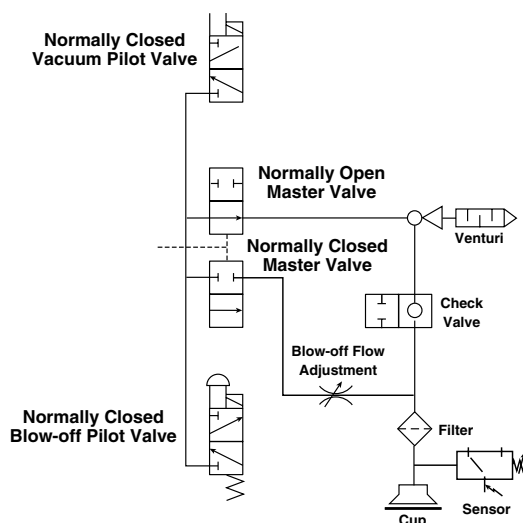

Valve controlled emergency stop circuit

(See CEK Vacuum Generator)

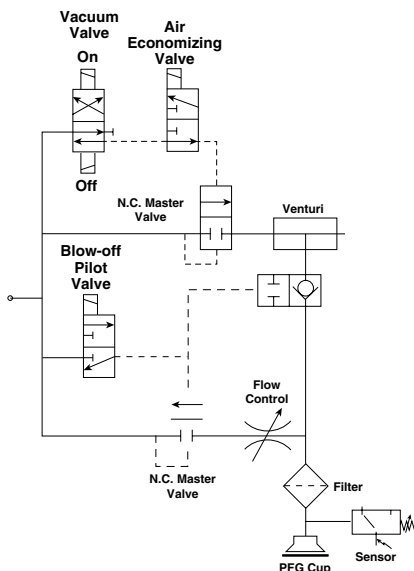

The venturi system

A closed vacuum system has a volume of air within all the components between the vacuum port of the venturi and the suction cup. The venturi's ability to evacuate this volume of air when the suction cup forms a seal on the surface, creates the pressure differential required to force the suction cup onto the product.

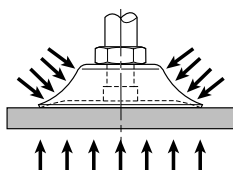

The evacuated air creates a lower air pressure within the closed vacuum system, causing the atmospheric pressure to apply a uniform force on the surface of the cup. This holding force is proportional to the difference in pressures and area of the suction cup.

Selecting the appropriate supply valve

If a basic venturi generator is selected, correct sizing of the air supply valve and supply line are critical to the performance of the unit.

Nozzle Diameter	Minimum Tube I.D. mm	Flow (Cv)
0.5 mm	4	0.16
1.0 mm	4	0.16
1.5 mm	6	0.379
2.0 mm	8	0.65
2.5 mm	8	0.95
3.0 mm	10	1.35

If pressure drops occur due to other pneumatic components or a manifold venturi system, it may be necessary to increase the valve and / or supply line tubing I.D..

Selecting the nozzle diameter with reference to suction cup diameter

As a general guide, for most non-porous vacuum applications, the nozzle diameter can be selected based on the suction cup diameter previously determined in Section A.

Nozzle diameter	Maximum suction cup diameter mm
0.5 mm	20
1.0 mm	50
1.5 mm	60
2.0 mm	120
2.5 mm	150
3.0 mm	200

Designing a system with a single suction cup dedicated to a single vacuum generator is ideal, however, it may not always be practical. It is recommended that the sum of the areas of multiple cups dedicated to a single venturi do not exceed the area of the diameter of the single suction cups shown above.

B

Selecting a generator size

The choice of Generator Series depends on the system requirements for components and overall performance for the application. Inline Generators offer the basic function for creating vacuum flow. Adding integrated components such as automatic blow off Controls, Vacuum and Blow-off Solenoids, Pressure Sensors, Check Valves and Filters are options that can reduce overall mounting space, reduce cycle time and can offer air conservation functions as well as emergency stop modes. For guidelines on selecting Vacuum Generators by features, consult the highlight features in the Generator Index section for each Series Section.

A vacuum source can only achieve and hold a degree of vacuum that sustains the amount of leakage into the vacuum system. In most cases, it is the leakage through the product and by of the cup seal that limits the system degree of vacuum. Products with high product leakage are Porous Applications. The degree of vacuum that can be obtained with this type of product can vary and tends to be below 10 inHg. Products with low or no leakage are called Non-Porous Applications. It can be assumed that the maximum degree of vacuum of the system is the maximum degree of the vacuum generator. Due to design cycle time and safety requirements, a lower degree of vacuum is generally chosen other than the maximum obtainable degree of vacuum. Chart 1 lists different units of measure for vacuum with typical application levels. The system degree of vacuum must be determined by product testing.

Chart 1: Basic vacuum pressure measurements units

Negative gauge pressure PSIG	Absolute pressure PSIA	Inches of mercury inHg
0	14.7	0
Atmospheric pressure at sea level		
-1.5	13.2	3
-3.0	11.7	6
-4.5	10.2	9
Typical porous vacuum level		
-6.0	8.7	12
-7.5	7.2	15
-9.0	5.7	18
-10.5	4.2	21
Typical non-porous vacuum level		
-12.0	2.7	24
-13.5	1.2	27
-14.7	0	29.92
Perfect vacuum (zero reference pressure)		

Evacuation time

The size of the generator generally refers to either the Evacuation Time or the Vacuum Flow Rates of the generator and varies by the size of the nozzle / diffuser.

Evacuation Time is the time required to evacuate the air out of a vacuum system to specific degree of vacuum. Typically, this degree of vacuum is a value where it is safe to move a product in a pick and place application and is determined by the design engineer. Evacuation Time can also be considered response time of the system.

A typical Evacuation Time chart for a generator series is shown in Chart 2. The time to achieve a given degree of vacuum in a 1 cubic foot volume is listed in seconds for each Generator.

Example: A pick and place application requires a 0.25 secs

for creation of 18 inHg of vacuum in the vacuum system. The vacuum system volume, which includes tubing and cups, is 0.002 ft³.

The evacuation time charts are given for a 1 cubic foot (ft³) volume. To use these charts, convert the time requirement of the system to an equivalent time for a 1 cubic foot (ft³) volume. In this example, 1 cubic foot (ft³) is 500 times the system volume of 0.002 ft³. Multiply the system time requirement by 500 (500 x 0.25 secs = 125 seconds). Any generator with a evacuation time of less than 125 seconds to attain 18 inHg can be chosen for this application. A CV-15-HS will meet the requirements for this application. A (-) listed means the generator will not obtain a higher degree of vacuum than the level of the first (-).

Chart 2: evacuation time

Series / nozzle diameter	Air supply pressure	Air consumption	Evacuation time in sec / ft ³ * to reach different vacuum levels (inHg)								
	PSI	SCFM	3	6	9	12	15	18	21	24	27
CV-05HS	70	0.46	24.3	57.3	101.0	160.5	231.1	305.1	433.1	597.7	—
CV-05LS	70	0.46	11.0	23.4	40.0	64.4	110.2	—	—	—	—
CV-10HS	70	1.55	4.8	9.9	16.0	24.9	35.9	51.4	77.4	117.5	226.0
CV-10LS	70	1.55	3.7	7.6	13.0	20.3	33.1	—	—	—	—
CV-15HS	70	3.53	2.5	4.8	7.0	11.0	15.5	22.0	31.9	46.6	112.1
CV-15LS	70	3.53	2.0	3.1	5.0	7.6	12.1	—	—	—	—
CV-20HS	70	6.36	1.7	2.8	5.0	6.5	9.0	13.0	18.9	27.4	60.7
CV-20LS	70	6.36	1.3	2.5	4.0	5.9	11.3	—	—	—	—

* 1 ft³ = 28.31 liters



Vacuum flow

A typical Vacuum Flow chart for a generator series is listed in Chart 3. The vacuum flow rate at given degree of vacuum is listed in SCFM for each Generator. This chart is generally used to determine the change of degree of vacuum given a change in vacuum flow rate of a generator.

Example. A CV-15HS can only obtain 9 inHg. The vacuum flow rate at 9 inHg is 1.50 SCFM. This means that the cup seal and

product leaks 1.50 SCFM of air. This generator can maintain the leak rate of 1.50 SCFM. Choosing a generator with more flow at 9 inHg will increase the degree of vacuum in the system because the generator can overcome more leakage. In this case, the vacuum flow rates are linear since this CV generator is a single stage venturi generator. Replacing a CV-15HS with CV-20HS will increase the degree of vacuum in the system to approximately 16.2 inHg. The CV-20HS now maintains 16.2 inHg at a flow rate of 1.50 SCFM.

Chart 3: Vacuum flow (SCFM)

Nozzle diameter	inHg										
	0	3	6	9	12	15	18	21	24	27	30
CV-05HS	.21	.19	.17	.15	.13	.11	.09	.07	.05	.03	—
CV-05LS	.32	.27	.22	.17	.12	.06	—	—	—	—	—
CV-10HS	.95	.85	.75	.65	.55	.45	.35	.25	.15	.05	—
CV-10LS	1.27	1.05	.83	.59	.38	.17	—	—	—	—	—
CV-15HS	2.22	1.98	1.74	1.5	1.26	1.01	.76	.51	.25	.10	—
CV-15LS	3.35	2.79	2.23	1.67	1.10	.53	—	—	—	—	—
CV-20HS	3.88	3.45	3.02	2.59	2.16	1.73	1.30	.87	.44	.25	—
CV-20LS	5.85	5.09	4.03	2.97	1.91	.85	—	—	—	—	—



Tubing reference

Tubing ID	Tubing length (L)	
	SAE mm	In. M
5/64	2	18 .457
3/32	2.38	24 .610
1/8	3.17	30 .762
5/32	4	36 .914
3/16	4.76	42 1.07
1/4	6.35	48 1.22
5/16	8	54 1.37
3/8	9.52	60 1.52
7/16	11.1	66 1.67

SAE x 25.4 = mm In. x 25.4 = M

Pad volume reference (pv)

PFG			PBG			PCG		
Ø	in ³	L	Ø	in ³	L	Ø	in ³	L
2	.00004	.0000006	10	.013	.0002	5	.002	.00003
3.5	.0001	.000002	15	.045	.0007	7	.003	.00004
5	.0003	.000005	20	.070	.001	10	.010	.0001
6	.00048	.000008	30	.28	.004	15	.060	.0009
8	.002	.00003	40	.56	.009	18	.082	.001
10	.004	.00007	50	1.60	.026	20	.123	.002
15	.012	.0002	75	4.63	.076	30	.595	.009
20	.03	.0005	110	6.77	.111	40	1.15	.018
25	.067	.0011	150	15.86	.26	60	4.40	.072
30	.067	.0011				90	10.00	.1639
35	.14	.0023						
40	.18	.003						
50	.25	.0042						
60	.57	.0094						
80	1.28	.021						
95	1.95	.032						
110	5.00	.082						
150	10.80	.177						
200	23.24	.381						

1 ft³ = 28.31 liters
 1 ft³ = 1728 in³

Nozzle diameter to tubing diameter to cup diameter reference

For each application, the size of the nozzle diameter, vacuum tubing I.D., and maximum cup diameter must be practical in relationship to each other. The chart to the right is a quick reference to aid in selecting the vacuum tubing I.D. and nozzle diameter given the maximum cup diameter.

As an example, one 60mm cup with 2 meters in tubing length would require a minimum 6mm I.D. vacuum tube and a 1.5mm nozzle. The same 60mm cup with 3.5 meters in tubing length would require a minimum 8mm I.D. vacuum tube and a 2.0mm nozzle to achieve an equivalent performance.

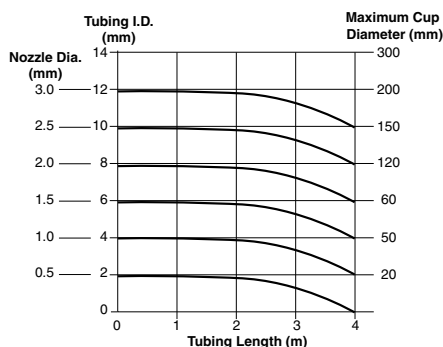

Evacuation time

Series / Nozzle diameter	Air supply pressure PSI	Air consumption SCFM	Evacuation time in sec / ft ³ * to reach different vacuum levels (inHg)								
			3	6	9	12	15	18	21	24	27
MCA10HS	70	1.68	5.1	11.0	18.0	28.2	41.0	58.2	83.1	123.2	—
MCA13HS	70	2.81	3.7	7.3	12.0	19.5	28.5	39.8	58.5	104.2	—
CV05HS	70	0.46	24.3	57.3	101.0	160.5	231.1	305.1	433.1	597.7	—
CV05LS	70	0.46	11.0	23.4	40.0	64.4	110.2	—	—	—	—
CV10HS	70	1.55	4.8	9.9	16.0	24.9	35.9	51.4	77.4	117.5	226.0
CV10LS	70	1.55	3.7	7.6	13.0	20.3	33.1	—	—	—	—
CV15HS	70	3.53	2.5	4.8	7.0	11.0	15.5	22.0	31.9	46.6	112.1
CV15LS	70	3.53	2.0	3.1	5.0	7.6	12.1	—	—	—	—
CV20HS	70	6.36	1.7	2.8	5.0	6.5	9.0	13.0	18.9	27.4	60.7
CV20LS	70	6.36	1.3	2.5	4.0	5.9	11.3	—	—	—	—
CV25HS	70	9.36	1.4	2.3	3.0	4.5	6.5	9.0	13.0	18.9	35.3
CV25LS	70	9.36	1.0	2.0	3.0	3.7	5.6	—	—	—	—
CV30AHS	70	13.60	1.1	2.0	2.8	3.5	4.8	6.8	9.6	16.7	29.1
CV30ALS	70	13.60	0.9	1.5	2.7	3.4	5.1	—	—	—	—
CV10HSCK	70	1.55	4.8	9.9	16.0	24.9	35.9	51.4	77.4	117.5	226.0
CV15HSCK	70	3.53	2.5	4.8	7.0	11.0	15.5	22.0	31.9	46.6	112.1
CV20HSCK	70	6.36	0.7	2.8	5.0	6.5	9.0	13.0	18.9	27.4	60.7
CHF20	80	6.5	0.21	0.64	1.70	4.03	7.63	11.65	19.28	33.48	94.50
CHF30	80	9.6	0.21	0.63	1.27	3.39	6.36	9.53	16.10	27.76	78.82
CHF40	80	14.0	0.17	0.42	1.27	2.33	4.03	5.93	9.75	16.95	47.67

* 1 ft³ = 28.31 liters

Vacuum flow (SCFM)

Nozzle diameter	nHg										
	0	3	6	9	12	15	18	21	24	27	30
MCA10HS	.88	.78	.68	.58	.47	.37	.26	.16	.06	—	—
MCA13HS	1.26	1.11	.96	.81	.67	.53	.39	.25	.11	—	—
CV05HS	.21	.19	.17	.15	.13	.11	.09	.07	.05	.03	—
CV05LS	.32	.27	.22	.17	.12	.06	—	—	—	—	—
CV10HS	.95	.85	.75	.65	.55	.45	.35	.25	.15	.05	—
CV10LS	1.27	1.05	.83	.59	.38	.17	—	—	—	—	—
CV15HS	2.22	1.98	1.74	1.50	1.26	1.01	.76	.51	.26	.10	—
CV15LS	3.35	2.79	2.23	1.67	1.10	.53	—	—	—	—	—
CV20HS	3.88	3.45	3.02	2.59	2.16	1.73	1.30	.87	.44	.25	—
CV20LS	5.85	5.09	4.03	2.97	1.91	.85	—	—	—	—	—
CV25HS	5.65	5.11	4.57	4.03	3.49	2.94	2.39	1.85	1.31	.77	—
CV25LS	8.83	7.29	5.75	4.21	2.67	1.13	—	—	—	—	—
CV30AHS	7.94	7.16	6.38	5.62	4.84	4.06	3.28	2.50	1.17	.92	—
CV30ALS	12.36	10.24	8.12	6.00	3.89	1.48	—	—	—	—	—
CV10HSCK	.95	.85	.75	.65	.55	.45	.35	.25	.15	.05	—
CV15HSCK	2.22	1.98	1.74	1.5	1.26	1.01	.76	.51	.25	.10	—
CV20HSCK	3.88	3.45	3.02	2.59	2.16	1.73	1.30	.87	.44	.25	—
CHF20	20.90	12.12	7.88	3.85	2.76	2.12	1.45	0.81	0.35	0.04	—
CHF30	26.30	15.27	9.89	4.84	3.46	2.68	1.83	1.02	0.42	0.05	—
CHF40	31.80	18.50	12.00	5.90	4.20	3.30	2.30	1.30	0.60	0.06	—

Evacuation time

Series / Nozzle diameter	Air supply pressure PSI	Air consumption SCFM	Evacuation time in sec / ft ³ to reach different vacuum levels (inHg)								
			3	6	9	12	15	18	21	24	27
MC2210HS	70	1.55	5.4	12.1	20.0	32.2	52.0	85.0	120.1	183.9	—
MC7215HS	70	3.53	2.59	5.39	8.99	13.89	20.66	29.36	45.16	69.6	208.23
MC7220HS	70	6.36	1.13	2.6	5.21	7.91	12.56	19.26	30.84	54.65	129.9
MC7225HS	70	10.42	0.66	2.19	3.29	6.14	9.3	14.55	23.21	46.13	—
CEK15HS	70	3.53	2.3	4.8	8.0	12.4	18.4	26.3	40.4	62.1	189.3
CEK20HS	70	6.36	1.1	2.5	5.0	7.6	12.1	18.6	29.9	53.4	129.9
CEK27HS	70	10.42	0.6	2.0	3.0	5.6	8.5	13.3	21.2	42.1	—
CVXCEK	70	10.42	0.6	2.0	3.0	5.6	8.5	13.3	21.2	42.1	—

* 1 ft³ = 28.31 liters

B

Vacuum flow (SCFM)

Nozzle diameter	nHg										
	0	3	6	9	12	15	18	21	24	27	30
MC2210HS	0.71	0.64	0.57	0.49	0.42	0.34	0.25	0.17	0.10	—	—
MC7215HS	2.2	1.96	1.71	1.47	1.22	0.99	0.75	0.51	0.27	—	—
MC7220HS	3.67	3.21	2.81	2.4	2.04	1.64	1.24	0.84	0.44	—	—
MC7225HS	5.2	4.61	4.01	3.41	2.82	2.22	1.63	1.04	0.46	—	—
CEK15HS	2.51	2.23	1.95	1.67	1.39	1.12	0.85	0.58	0.30	—	—
CEK20HS	3.75	3.34	2.93	2.50	2.12	1.70	1.28	0.86	0.44	—	—
CEK27HS	5.75	5.09	4.43	3.77	3.11	2.45	1.80	1.15	0.50	—	—
CVXCEK	5.75	5.09	4.43	3.77	3.11	2.45	1.80	1.15	0.50	—	—

Parker Inline Single Stage Vacuum Generators is a compact design offering multiple vacuum flow ranges in 3 styles. These Generators are meant to be mounted near the vacuum application for improved vacuum response time. A Normally Open or Normally Closed 3 way valve can be used to control the supply pressure to obtain up to a 0.91 bar degree of vacuum.

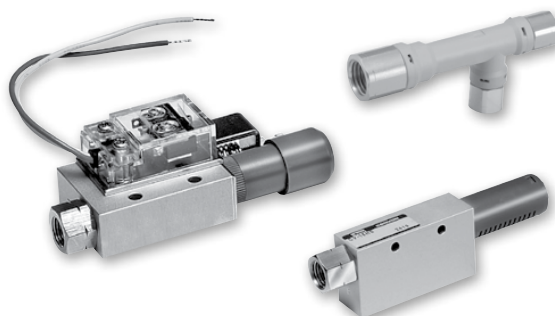

B

Features

- **MCA:**
 - light weight vacuum generator
 - vacuum flow rates to 35 l/mn
- **CV:**
 - basic aluminum body generator with exhaust muffler
 - vacuum flow rates to 350 l/mn
 - degree of vacuum to 0.91 bar
- **CV-CK**
 - basic aluminum body generator with mechanical vacuum switch
 - vacuum flow rates to 165 l/mn
 - degree of vacuum to 0.91 bar

Specifications

Media	Non-lubricated air, non-corrosive gases
Operating pressure	1 to 8 bar (14 to 114 PSI)
Operating temperature	0° to 50°C (MCA, CV) - 0° to 60°C (CV, CK)
Material	Polycarbonate, Aluminum fittings (MCA) Body: Aluminum (CV, CV-CK) Nozzle: Nickel plated brass (CV, CV-CK)
CV-CK Switch	Setting range: 0,2 to 0,5 bar, accuracy ± 0,05 bar Hysteresis: 37 to 132 mbar Switch output: N.O., AC125V; 5A, AC250V: 3A, DC250V: 0.2A

Model numbers

Symbol	Port size			Max. vacuum flow l/mn	Air consumption l/mn	Max. degree of vacuum inHg	Part number	
	Pressure	Vacuum	Exhaust				BSPB	NPT
	1/8	1/8	1/4	47.6	47.6	24	MCA10HSG1G1G2	MCA10HSN1N1N2
	1/4	1/4	1/4	79.6	79.6	24	MCA13HSG1G1G2	MCA13HSN1N1N2
	1/8	1/8	Muffler	6	13	27	CV05HSG	CV05HSN
	1/8	1/8	Muffler	9	13	17	CV05LSG	CV05LSN
	1/8	1/8	Muffler	27	43.9	27	CV10HSG	CV10HSN
	1/8	1/8	Muffler	36	43.9	17	CV10LSG	CV10LSN
	1/4	3/8	Muffler	63	100	27	CV15HSG	CV15HSN
	1/4	3/8	Muffler	95	100	17	CV15LSG	CV15LSN
	1/4	3/8	Muffler	110	180	27	CV20HSG	CV20HSN
	1/4	1/2	Muffler	165	180	17	CV20LSG	CV20LSN
	3/8	1/2	Muffler	160	265	27	CV25HSG	CV25HSN
	3/8	1/2	Muffler	250	265	17	CV25LSG	CV25LSN
	1/2	3/4	Muffler	225	385	27	CV30AHSG	CV30AHSN
1/2	3/4	Muffler	350	385	17	CV30ALSG	CV30ALSN	
	1/8	1/8	—	27	44	27	CV10HSCKG	CV10HSCKN
	1/4	1/4	—	63	100	27	CV15HSCKG	CV15HSCKN
	1/4	3/8	—	110	180	27	CV20HSCKG	CV20HSCKN

Dimensions

MCA

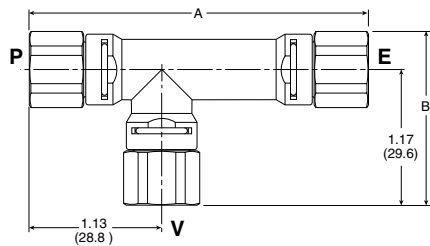

MCA Mounting bracket: MCA-B

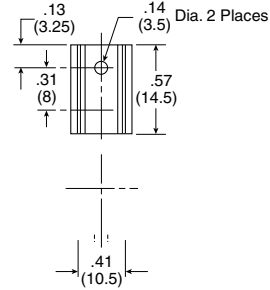

MCA**N1N1N2**

Dimensions (mm)

Item	A	B
MCA10HS*****	70	29.5
MCA13HS*****	70	29.5

CV

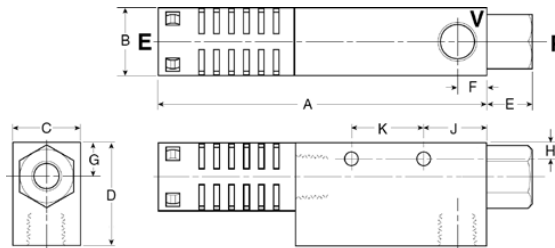

Dimensions (mm)

Item	A	B	C	D	E	F	G	H	J	K
CV05HS/LS	81	18.5	16	33	10	8	10	4.5	14	20
CV10HS/LS	81	18.5	16	33	10	8	10	4.5	14	20
CV15HS/LS	108.5	20	20	35	15	10	11	5	20	25
CV20HS/LS	145.5	30	30	40	20	13	15	7	28	32
CV25HS/LS	196	40	40	60	17	16	20	5.5	20	50
CV30AHS/ALS	214	40	40	60	20	20	20	5.5	33	50

CV-CK

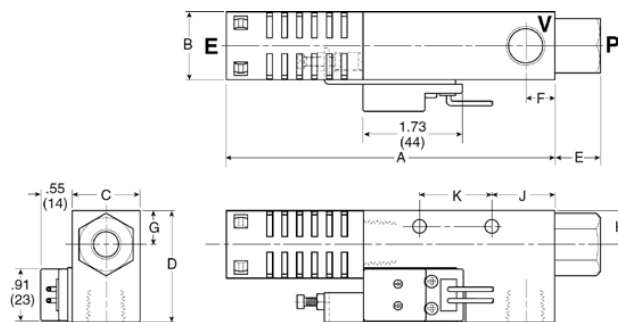

Dimensions (mm)

Item	A	B	C	D	E	F	G	H	J	K
CV10HS/LSCK	81	18.5	16	33	10	8	10	4.5	4.2	20
CV15HS/LSCK	108.5	20	20	35	15	10	11	5	4.5	25
CV20HS/LSCK	145.5	30	30	40	20	13	15	7	6	32



The MC22 is a complete package for factory automation. The MC22 has integrated vacuum generating and blow-off release pilot valves to minimize the response time to achieve vacuum. The small foot print and lightweight body allows the unit to be located close to the suction cup for maximum performance. The MC22 has additional features; regulating blow-off needle, 37 micron mesh filter, and a sensor platform for vacuum confirmation. The MC22 can be assembled into a maximum 8 station manifold. The unit can be ordered normally open or normally closed, with or without MPS-23 or MVS-201 pressure sensors.

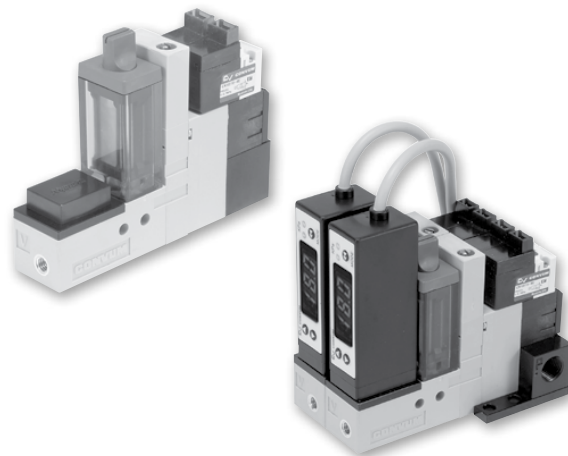

Add-A-Fold Manifold

B Features

- Vacuum generating pilot valve
- Vacuum blow-off pilot valve
- Vacuum sensor - filter - silencer available
- Regulating blow-off adjustment
- Manifold system
- Short cycle times for high speed pick and place
- Vacuum flow rates to 44 l/mn

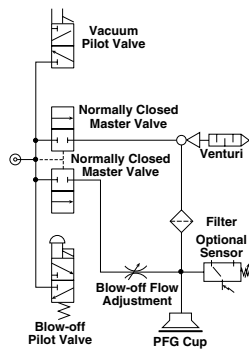

MC2, Normally Closed Vacuum Valve

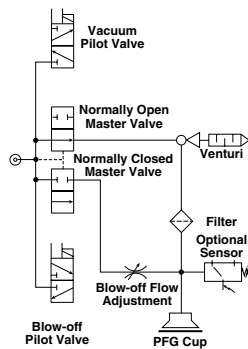

MC2, Normally Open Vacuum Valve

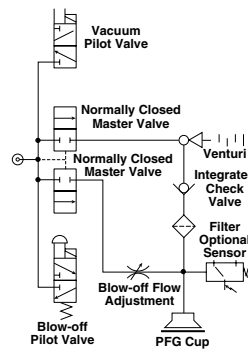

MC2, Normally Closed Vacuum Valve with Integrated Check Valve

Specifications

Media	Non-lubricated compressed air, non-corrosive gases
Operating pressure	1.5 to 5.8 bar (21 to 84 PSI)
Optimum operating pressure	4.8 bar (70 PSI)
Humidity	35 to 85%
Pressure port	G: 1/8 BSPP female, N: 1/8 NPT female
Vacuum port	M5 female
Operating temperature	5°C to 50°C
Material	Aluminum, Polyamide, NBR
Vacuum generating and blow-off release pilot	
Type of control valve	Pilot valve, includes 300mm clip wire connector
Manual operation	Non-locking manual override
Electrical connection	Clip type connector with LED and surge protection
Power supply	24VDC ± 10%
Power consumption	1W
Pressure range	1.5 to 5.8 bar (21 to 84 PSI)
Pilot valve air supply	Normally closed
Generator weight	117g without sensor
Manifold weight	2-Station: 40g, 3-Station: 54g, 4-Station: 68g, 5-Station: 82g 6-Station: 96g, 7-Station: 110g, 8-Station: 124g



MC2 unit without integrated check valve, normally closed vacuum valve

Port size			Max. vacuum flow l/mn	Max. degree of vacuum inHg	Sensor option	Part number
Pressure	Vacuum	Exhaust				NPT
1/8	M5	Muffler	44	24	None	MC22S10HSZL4BLN
1/8	M5	Muffler	44	24	MPS-V23C-PC, PNP	MC22S10HS42L4BLN
1/8	M5	Muffler	44	24	MVS-201-PCP, PNP	MC22S10HS06L4BLN
1/8	M5	Muffler	44	24	MPS-V23C-NC, NPN	MC22S10HS41L4BLN
1/8	M5	Muffler	44	24	MVS-201-NC, NPN	MC22S10HS01L4BLN

B

MC2 unit without integrated check valve, normally open vacuum valve

Port size			Max. vacuum flow l/mn	Max. degree of vacuum inHg	Sensor option	Part number
Pressure	Vacuum	Exhaust				NPT
1/8	M5	Muffler	44	24	None	MC22S10HSZL4ALN
1/8	M5	Muffler	44	24	MPS-V23C-PC, PNP	MC22S10HS42L4ALN
1/8	M5	Muffler	44	24	MPS-V23C-NC, NPN	MC22S10HS41L4ALN

MC2 unit with integrated check valve, normally closed vacuum valve

Port size			Max. vacuum flow l/mn	Max. degree of vacuum inHg	Sensor option	Part number
Pressure	Vacuum	Exhaust				NPT
1/8	M5	Muffler	44	24	None	MC22S10HSZLC4BLN
1/8	M5	Muffler	44	24	MPS-V23C-PC, PNP	MC22S10HS42LC4BLN
1/8	M5	Muffler	44	24	MVS-201-PCP, PNP	MC22S10HS06LC4BLN
1/8	M5	Muffler	44	24	MPS-V23C-NC, NPN	MC22S10HS41LC4BLN
1/8	M5	Muffler	44	24	MVS-201-NC, NPN	MC22S10HS01LC4BLN

MC22 with MPS-23 series

The "V23" sensor has 2 independent NPN or PNP outputs available for vacuum confirmation. The output response time of this sensor is less than 2 msec.

The "V23" sensor is available with an M8, 4 Pin Connector, on 1M Cable. The mating M8, 4-Pin cable must be ordered separately.

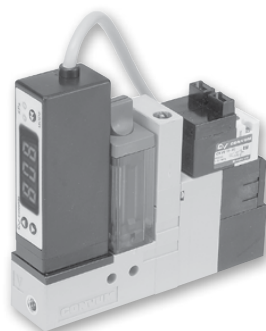

B

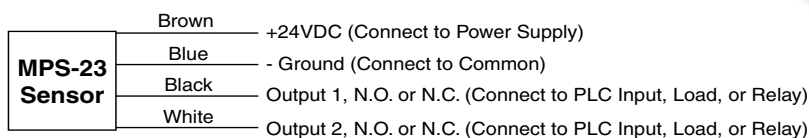

Output Adjustment

Sensor functions and outputs are programmed by touch panel.

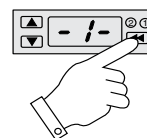

Basic System

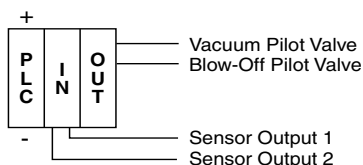

Air-Economizing System

N.C. Output 1 - Air Economizing
 N.O. Output 2 - Part Present Output

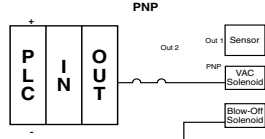

Vacuum System Programming

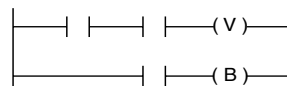

MC22 with MVS-201 series

The "201" sensor has one output NPN or PNP for vacuum confirmation and a control output that interfaces directly with the blow-off release pilot valve. With programmable time control features and a special chip driver, the sensor automatically activates the blow-off release when the NPN or PNP input vacuum signal from the PLC is discontinued. This eliminates a PLC output to activate the blow-off release. This new technology reduces PLC output requirements by 50% and reduces installation to a simple 4 wire system. The output response of the sensor is less than 2 msec.

The "201" sensor is available with an M8, 4-Pin electrical connector. The MC22-201 valve cable is included with the MVS-201 Sensor Option. The mating M8, 4-Pin cable must be ordered separately.

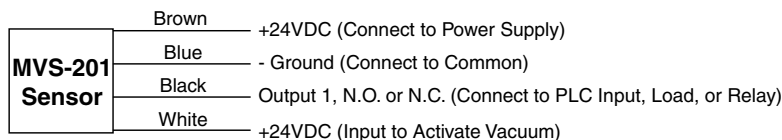
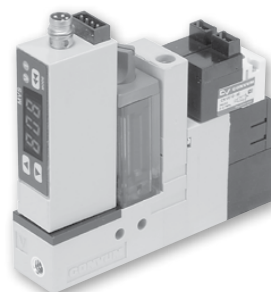

Basic System with 201 Sensor

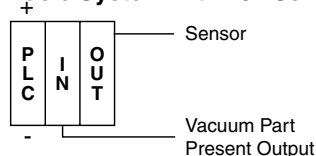

Vacuum System Programming

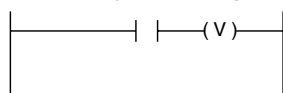

Output Adjustment

Sensor functions and outputs are programmed by touch panel.

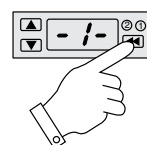



Station 1 Station 2

Manifold part number

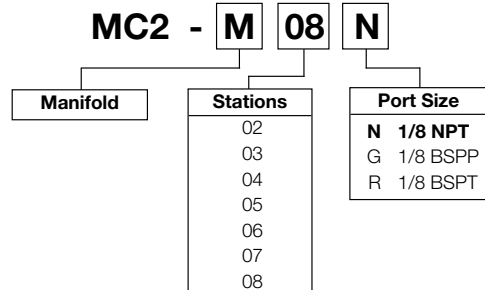

B

Generator

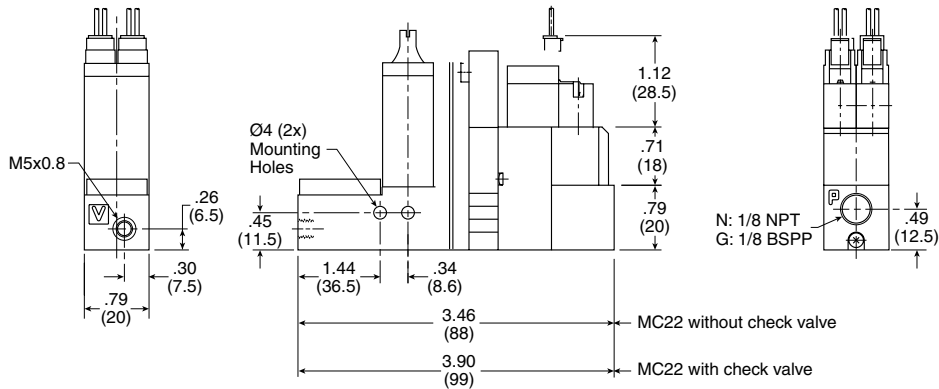

B

Manifold

3-Station manifold
without check
valve shown

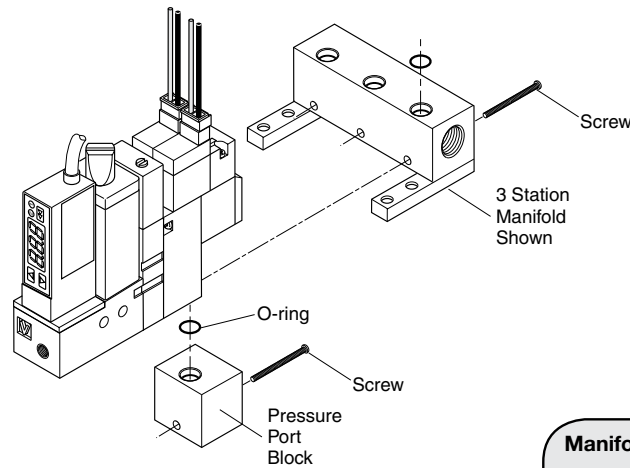
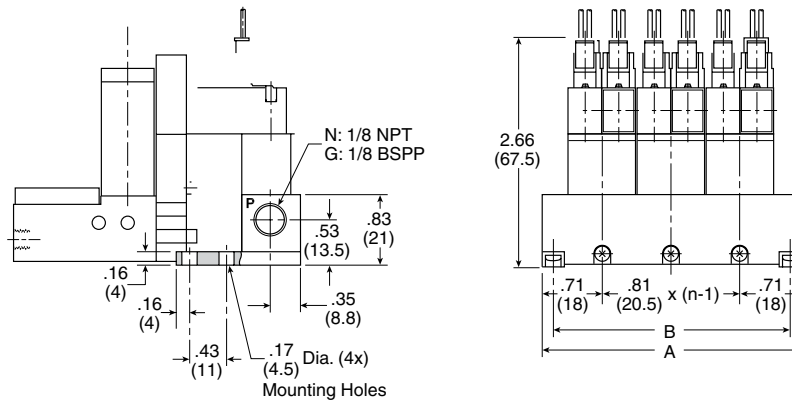

Manifold assembly
Remove Pressure Port Block and use existing o-ring and screw to secure the MC22 unit to the MC2 manifold.

Dimensions (mm)

n	2	3	4	5	6	7	8
A	56.5	77	97.5	118	138.5	159	179.5
B	48.5	69.0	89.5	110	130.5	151	171.5

n = Number of Stations



Replacement components

Item	Part number	Description
1	MC2-S	Silencer
2, 3, 4	MC2-F	Filter kit
3	MC2-E	Filter element
5, 7	CKV010-4E	Vacuum pilot valve
6, 7	CKV010-4E	Blow-off pilot valve
7	N/A	300mm clip lead
8	MC2-B	Mounting kit
9	MPS-V23C-NC	MPS-V23 (NPN) option
	MPS-V23C-PC	MPS-V23 (PNP) option
	MVS-201-NC	MVS-201 (NPN) option
	MVS-201-PCP	MVS-201 (PNP) option

B

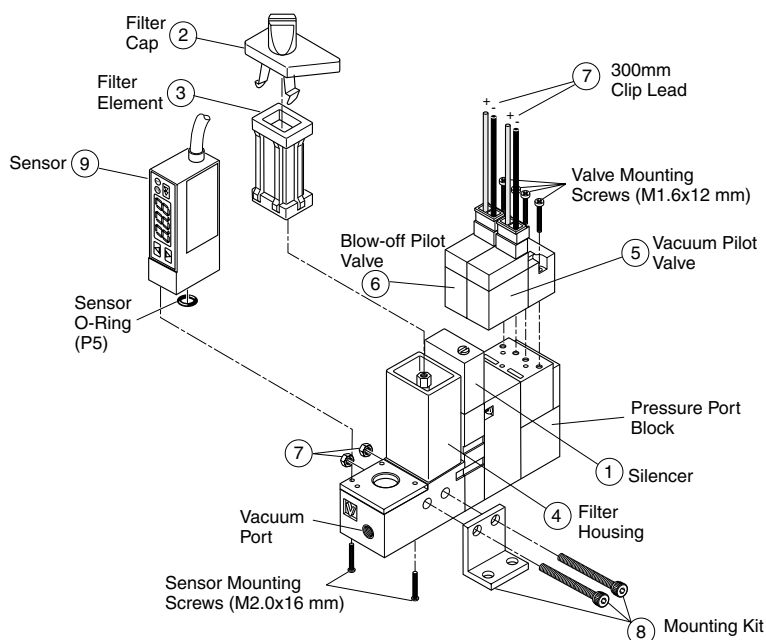

MC22 Accessories

Description	Part number
MC22 - C201G sensor / valve connector* (connects sensor to vacuum & blow-off release pilot valves) * Included with MVS-201 sensor option 01 & 06.	MC22-C201G
MC2-MM manifold blank plate kit* * includes blank plate, screws & gasket	MC2-M
Clip electrical connector, 600mm lead length	CA2-V4-6
Clip electrical connector, 1500mm lead length	CA2-V4-15

The MC72 Series vacuum generator provides a complete solution for factory automation. The MC72 is perfect for non-porous applications such as material handling, critical applications involving glass, or general transfer applications. The MC72 has integrated vacuum pilot and blow-off release pilot valves to minimize response times. The MC72 has additional features; regulating blow-off needle, 130 micron filter, optional check valve, and a sensor platform for vacuum confirmation. The MC72 can be assembled into a maximum 5 station manifold. The unit can be ordered normally open or normally closed.

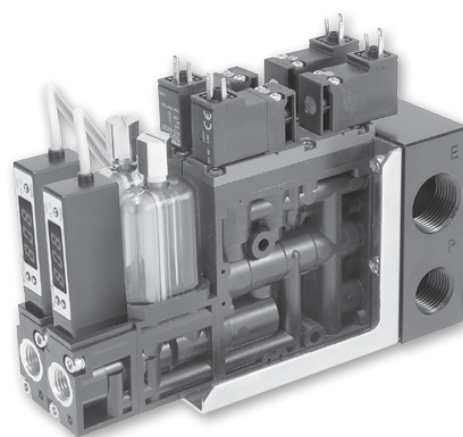
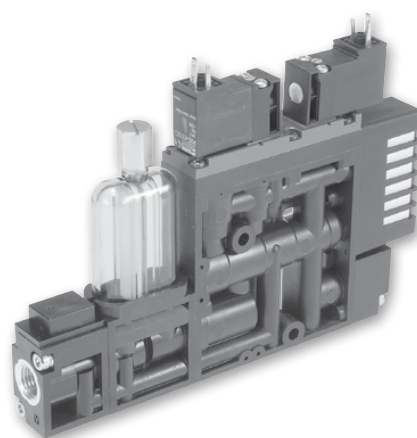

Add-A-Fold assembly (Silencer included)

B

Features

- Vacuum generating pilot valve
- Vacuum release pilot valve option
- Vacuum sensor - filter - silencer available
- Regulating blow-off
- Check valve option
- Air-economizing controls
- Manifold system
- Vacuum flow rates from 60 to 155 l/mn
- 3-Pin, EN175301-803, 15mm, 8mm 3-Pin

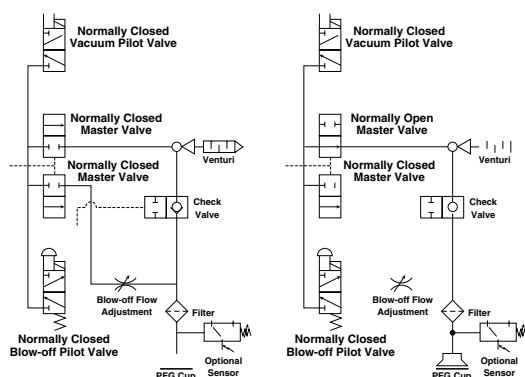

Specifications

Media	Non-lubricated compressed air, non-corrosive gases
Optimum operating pressure	4.8 bar (70 PSI)
Humidity	35 to 85%
Pressure port	G: 1/4 BSPP female N: 1/4 NPT female
Vacuum port	G: 1/4 BSPP female N: 1/4 NPT female
Operating temperature	5°C to 50°C
Material	Body (PA and PBT) with other internal components (Brass, Al, NBR, SUS, FKM), filter elements (PVF)
Manual operation	Non-locking manual override
Electrical connection	DIN connector with LED and surge protection
Power supply	24VDC ± 10%
Power consumption	1.8W
Operating pressure	4.8 bar (70 PSI)
Pilot valve air supply	Normally closed
Generator weight	750g
Manifold weight	2-Station: 680g, 3-Station: 880g, 4-Station: 1080g, 5-Station: 1280g



MC72 unit with integrated check valve, normally closed vacuum valve

Port size			Max. vacuum flow l/mn	Max. degree of vacuum inHg	Sensor option	Part number	
Pressure	Vacuum	Exhaust				BSPP	NPT
1/4	3/8	Muffler	62	24	No sensor	MC72S15HSZSC4BPG	MC72S15HSZSC4BPN
1/4	3/8	Muffler	62	24	MPS-V23C-PC, PNP	MC72S15HS42C4BPG	MC72S15HS42C4BPN
1/4	3/8	Muffler	62	24	MVS-201-PCP, PNP	MC72S15HS06C4BPG	MC72S15HS06C4BPN
1/4	3/8	Muffler	62	24	MPS-V23C-NC, NPN	MC72S15HS41C4BPG	MC72S15HS41C4BPN
1/4	3/8	Muffler	62	24	MVS-201-NC, NPN	MC72S15HS01C4BPG	MC72S15HS01C4BPN
1/4	3/8	Muffler	104	24	No sensor	MC72S20HSZSC4BPG	MC72S20HSZSC4BPN
1/4	3/8	Muffler	104	24	MPS-V23C-PC, PNP	MC72S20HS42C4BPG	MC72S20HS42C4BPN
1/4	3/8	Muffler	104	24	MVS-201-PCP, PNP	MC72S20HS06C4BPG	MC72S20HS06C4BPN
1/4	3/8	Muffler	104	24	MPS-V23C-NC, NPN	MC72S20HS41C4BPG	MC72S20HS41C4BPN
1/4	3/8	Muffler	104	24	MVS-201-NC, NPN	MC72S20HS01C4BPG	MC72S20HS01C4BPN
1/4	3/8	Muffler	147	24	No sensor	MC72S25HSZSC4BPG	MC72S25HSZSC4BPN
1/4	3/8	Muffler	147	24	MPS-V23C-PC, PNP	MC72S25HS42C4BPG	MC72S25HS42C4BPN
1/4	3/8	Muffler	147	24	MVS-201-PCP, PNP	MC72S25HS06C4BPG	MC72S25HS06C4BPN
1/4	3/8	Muffler	147	24	MPS-V23C-NC, NPN	MC72S25HS41C4BPG	MC72S25HS41C4BPN
1/4	3/8	Muffler	147	24	MVS-201-NC, NPN	MC72S25HS01C4BPG	MC72S25HS01C4BPN

B

MC72 unit with integrated check valve, normally open vacuum valve

Port size			Max. vacuum flow l/mn	Max. degree of vacuum inHg	Sensor option	Part number	
Pressure	Vacuum	Exhaust				BSPP	NPT
1/4	3/8	Muffler	62	24	No sensor	MC72S15HSZSC4APG	MC72S15HSZSC4APN
1/4	3/8	Muffler	62	24	MPS-V23C-PC, PNP	MC72S15HS42C4APG	MC72S15HS42C4APN
1/4	3/8	Muffler	62	24	MPS-V23C-NC, NPN	MC72S15HS41C4APG	MC72S15HS41C4APN
1/4	3/8	Muffler	104	24	No sensor	MC72S20HSZSC4APG	MC72S20HSZSC4APN
1/4	3/8	Muffler	104	24	MPS-V23C-PC, PNP	MC72S20HS42C4APG	MC72S20HS42C4APN
1/4	3/8	Muffler	104	24	MPS-V23C-NC, NPN	MC72S20HS41C4APG	MC72S20HS41C4APN
1/4	3/8	Muffler	147	24	No sensor	MC72S25HSZSC4APG	MC72S25HSZSC4APN
1/4	3/8	Muffler	147	24	MPS-V23C-PC, PNP	MC72S25HS42C4APG	MC72S25HS42C4APN
1/4	3/8	Muffler	147	24	MPS-V23C-NC, NPN	MC72S25HS41C4APG	MC72S25HS41C4APN

MC72 with MPS-23 series

The "V23" sensor has 2 independent NPN or PNP outputs available for vacuum confirmation. The output response time of this sensor is less than 2 msec.

The "V23" sensor is available with an M8, 4-Pin or grommated (2M) electrical connector. The mating M8, 4-Pin cable is not included with the MPS-23 Sensor and must be ordered separately.

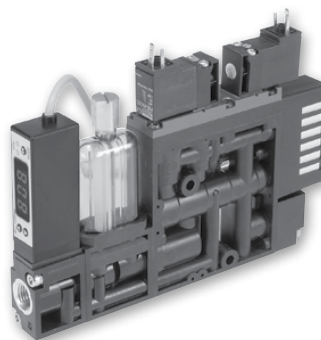

Output Adjustment

Sensor functions and outputs are programmed by touch panel.

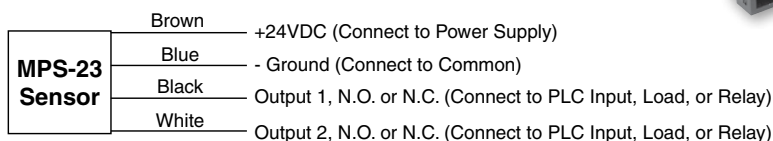
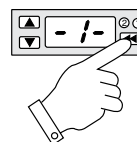

Basic System

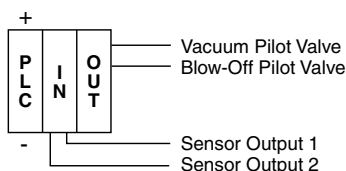

Air-Economizing System

N.C. Output 1 - Air Economizing
 N.O. Output 2 - Part Present Output
 PNP

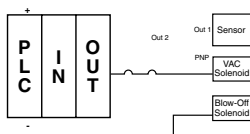

Vacuum System Programming

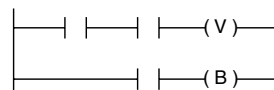

MC72 with MVS-201 series

The "201" sensor has one output NPN or PNP for vacuum confirmation and a control output that interfaces directly with the blow-off release pilot valve. With programmable time control features and a special chip driver, the sensor automatically activates the blow-off release when the NPN or PNP input vacuum signal from the PLC is discontinued. This eliminates a PLC output to activate the blow-off release. This new technology reduces PLC output requirements by 50% and reduces installation to a simple 4 wire system. The output response of the sensor is less than 2 msec.

The "201" sensor is available with an M8, 4-Pin electrical connector. The CVK-D201G valve cable is included with the MVS-201 Sensor Option. The mating M8, 4-Pin cable must be ordered separately.

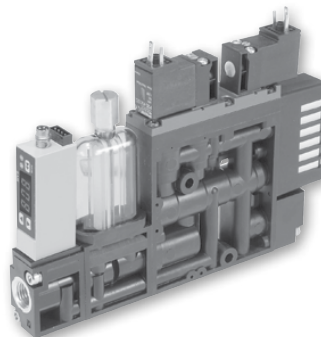

Output Adjustment

Sensor functions and outputs are programmed by touch panel.

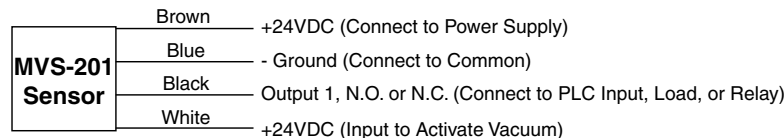
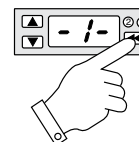

Basic System with 201 Sensor

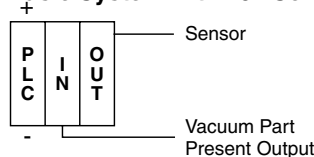

Vacuum System Programming

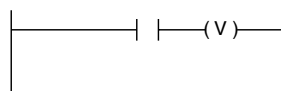

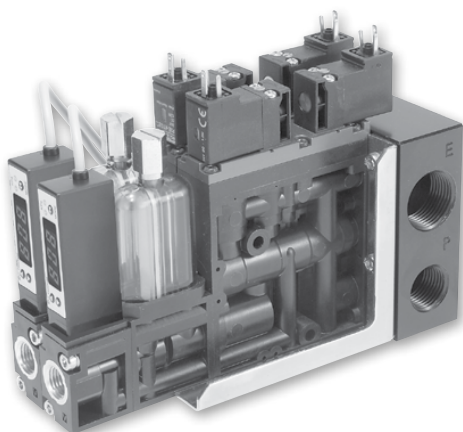

Manifold part number (without MC72 vacuum generator)

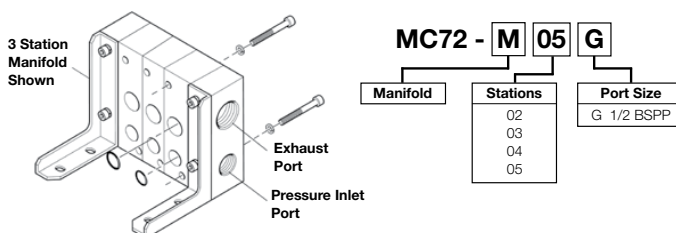

Note) for complete Manifold including MC72 vacuum generators, please contact us.

B

Separated elements

	Description	Order code
	End plate	MC7-MB-G
	Vacuum Generator Sub-base	MC7-MB

Manifold Assembly

Manifold assembly

1. Assemble manifold sections to manifold end plates as shown.
2. Assemble vacuum generator by removing pressure block and exhaust muffler. Then install using screws from manifold kit and existing O rings on MC72 unit.

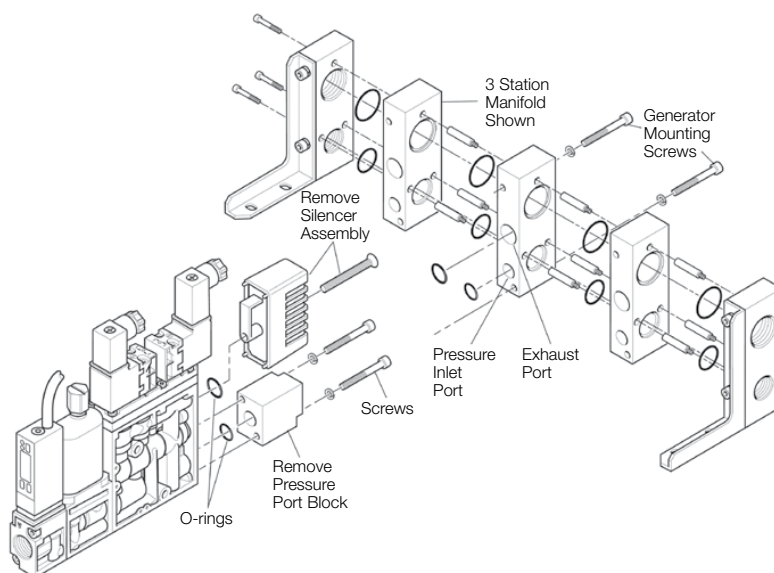

Generator

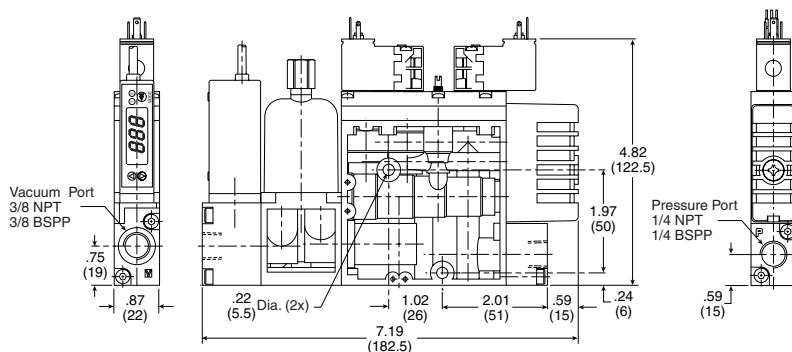

B

Manifold

3-Station manifold shown

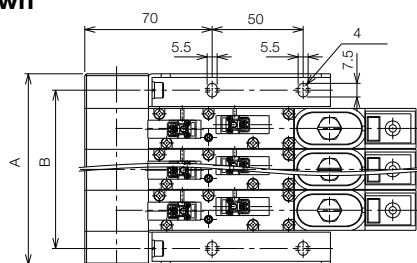

n	2	3	4	5
A	82,5	105	127,5	150
B	64,5	87	109,5	132

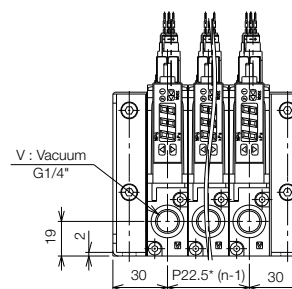
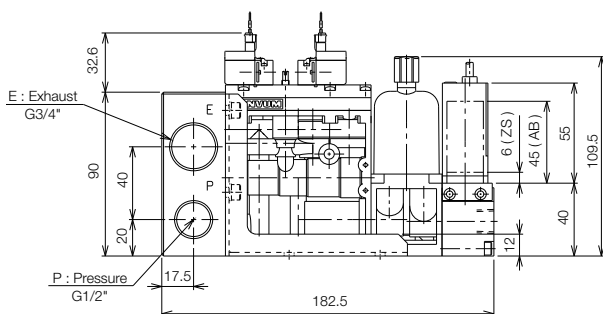

Vacuum Generator Sub-base

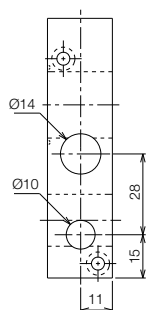
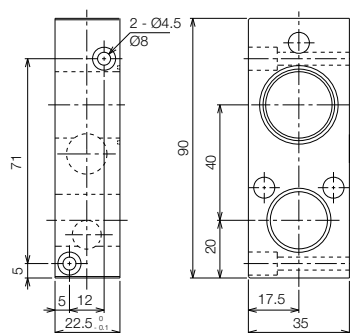

End Plates

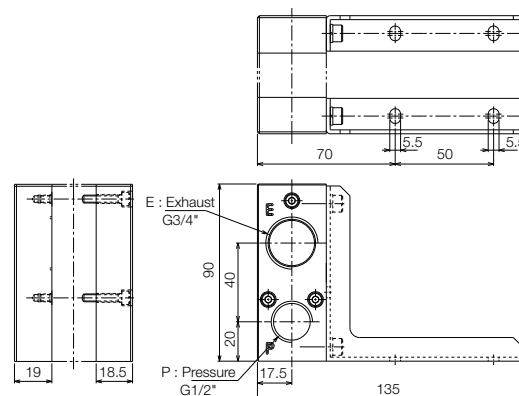

Replacement components

Item	Part number	Description
1	CVK-S	Silencer
2 thru 7	CVK-F	Filter kit
5	CVK-E	Filter element
8	P8C-D26C	DIN connector with LED
8, 9, 10	MC72-4PD	Pilot valve kit
11	MPS-V23C-NC	MPS-V23 (NPN) option
	MPS-V23C-PC	MPS-V23 (PNP) option
	MVS-201-NC	MVS-201 (NPN) option
	MVS-201-PCP	MVS-201 (PNP) option

B

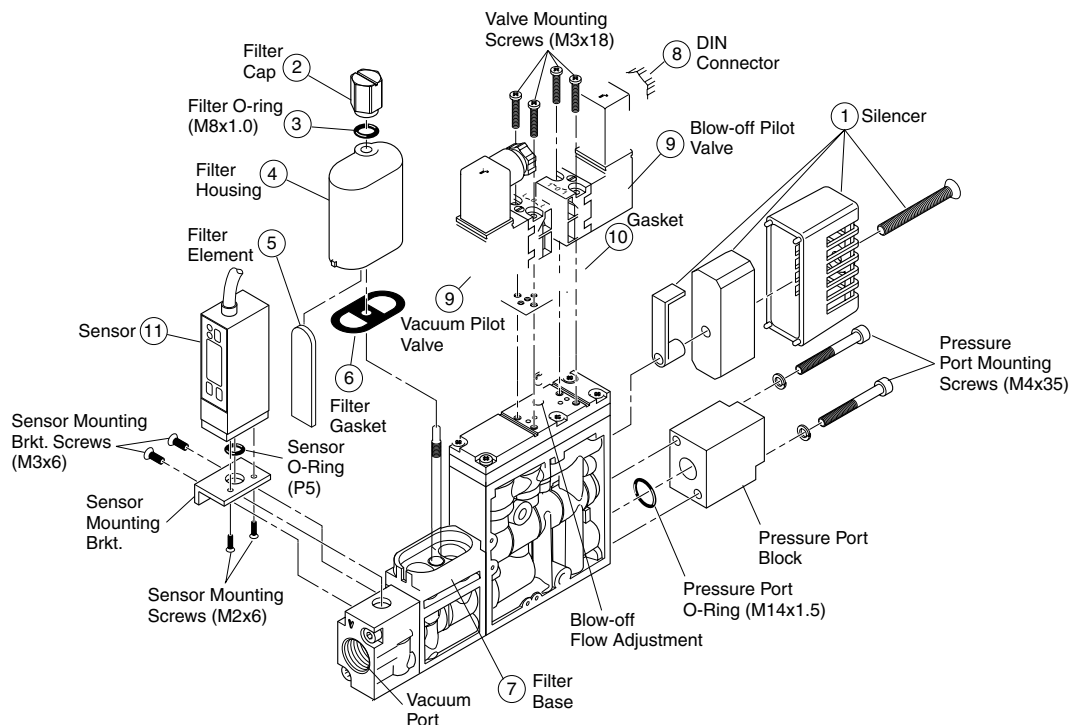

CVK-D201G Valve Cable*

(Connects Sensor to Vacuum & Blow-off Release Pilot Valves)

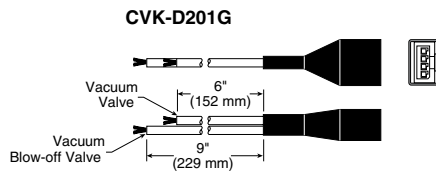

* Included with MVS-201 Sensor Option 01 & 06.

Generator Blank Plate Kit

CVK-BLK

Kit includes: Blank plate, screws & o-rings

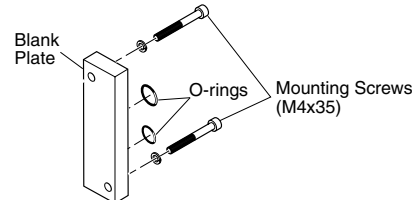

The CEK is a Normally Closed Vacuum On / Off valve that maintains the last state of air during an emergency stop or power loss. In addition to this, an air-economizing valve has been added to interrupt the air supply by connecting the output signal from the sensor to minimize air consumption.

This unit is ideal for non-porous applications that require fast response of large vacuum and blow-off release flow.

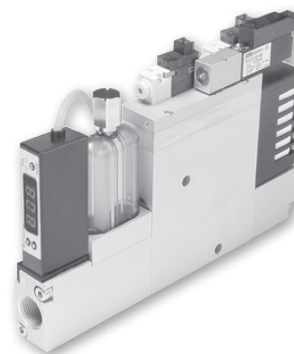

B

Typically, with a normally closed air circuit, the user controls vacuum with a command signal. During an Emergency Stop Event or power failure event, the vacuum command signal is lost, but, the Vacuum valve (1) remains in the current operating position due to the construction of the valve. The air-economizing valve (5), in a Normally Open configuration, passes the air supply from the Vacuum On / Off valve (1). The Sensor (2) output activates the air-economizing valve (5) closing the air supply to the Normally Closed master valve. The Check Valve (3) maintains the achieved vacuum level until the hysteresis value of the Sensor (2) is reached or when the Vacuum valve (1) has been returned to the closed position to stop the vacuum operation.

Valve controlled emergency stop circuit

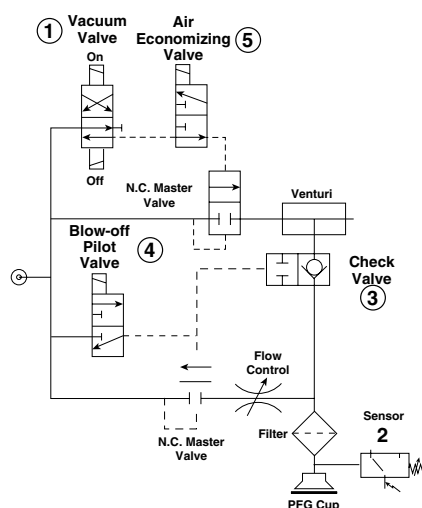

Features

- Integrated double solenoid for last state
- Integrated vacuum pilot
- Integrated blow-off pilot
- Integrated filter, silencer
- Air economizing capabilities
- Manifolds for up to 5 units

Model numbers

Nozzle size	Maximum degree of vacuum	Sensor option	Valve option	Part number
1.5mm	27 inHg	No Sensor	24 VDC, PNP	CEK15HSZC24PBLN
		MPS-V23 (NPN)	24 VDC, NPN	CEK15HS41C24NBLN
		MPS-V23 (PNP)	24 VDC, PNP	CEK15HS42C24PBLN
2.0mm	27 inHg	No Sensor	24 VDC, PNP	CEK20HSZC24PBLN
		MPS-V23 (NPN)	24 VDC, NPN	CEK20HS41C24NBLN
		MPS-V23 (PNP)	24 VDC, PNP	CEK20HS42C24PBLN
2.7mm	27 inHg	No Sensor	24 VDC, PNP	CEK27HSZC24PBLN
		MPS-V23 (NPN)	24 VDC, NPN	CEK27HS41C24NBLN
		MPS-V23 (PNP)	24 VDC, PNP	CEK27HS42C24PBLN

Most popular.



Specifications

Media	Non-lubricated compressed air, non-corrosive gases	
Operating pressure	4.8 bar (70 PSI)	
Humidity	35 to 85%	
Pressure port	G: 1/4 BSPP female, N: 1/4 NPT female	
Vacuum port	G: 3/8 BSPP female, N: 3/8 NPT female	
Operating temperature	5°C to 50°C	
Material	Aluminum, Brass, NBR	
Air-economizing valve and blow-off release pilot		Emergency stop valve
Type of control valve	Pilot valve	Double solenoid
Manual operation	Manual override	Manual overrides
Electrical connection	Clip connector with LED and surge	Clip connector with LED and surge
Power supply	24VDC ± 10%	24VDC ± 10%
Power consumption	0.9W	0.9W
Operating pressure	4.8 bar (70 PSI)	4.8 bar (70 PSI)
Air supply	Normally closed	Normally closed
Generator weight	750g	
Manifold weight	2-Station: 680g, 3-Station: 880g, 4-Station: 1080g, 5-Station: 1280g	

B

Manifold part number (without CEK vacuum generator)

B

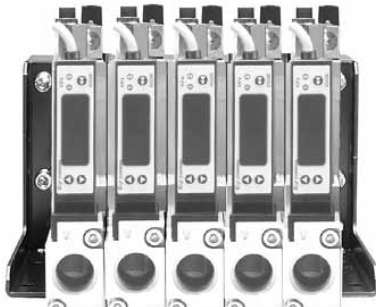
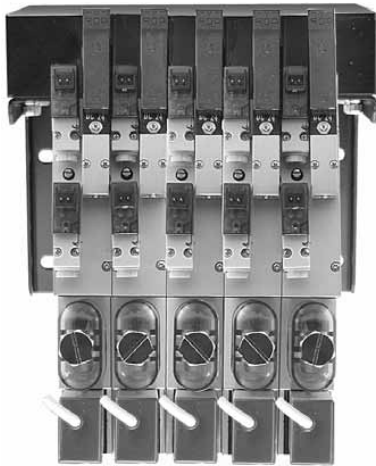

Station 1 Station 2 Station 3 Station 4 Station 5

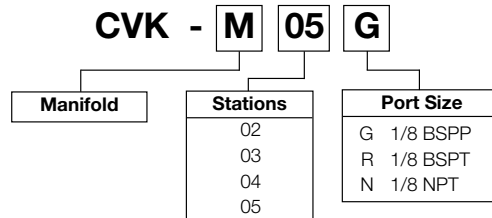

Generator

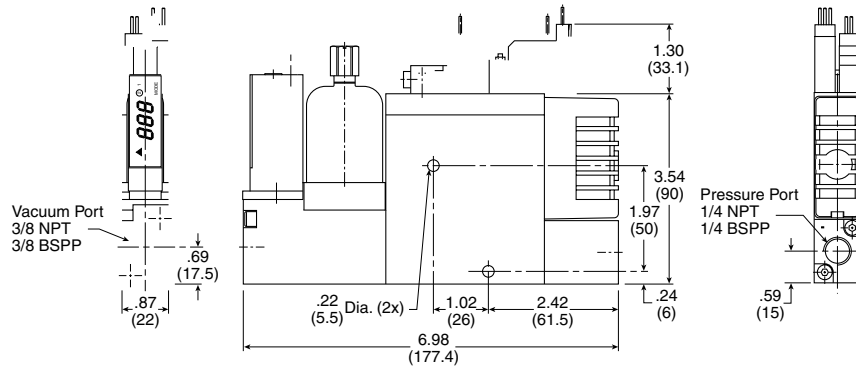

B

Manifold

3-Station manifold shown

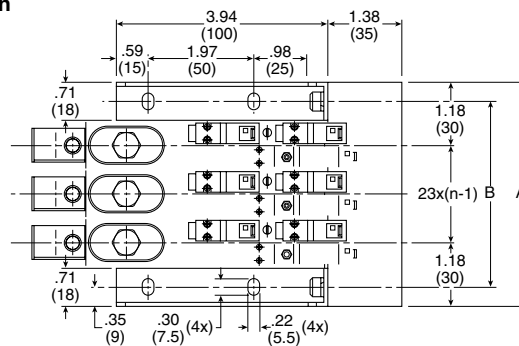

n	2	3	4	5
A	83	106	129	152
B	65	88	111	134

n = Number of Stations

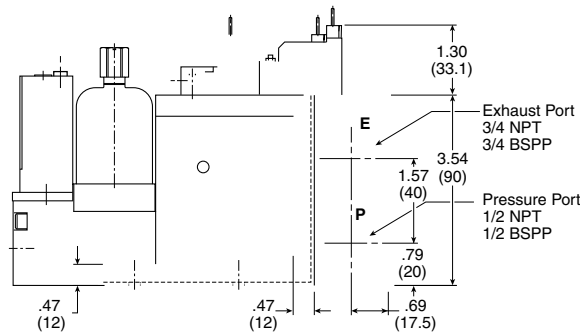

Manifold assembly
 Remove Pressure Port Block and Silencer Assembly. Use existing o-rings and manifold mounting screws to secure the CEK unit to the manifold.

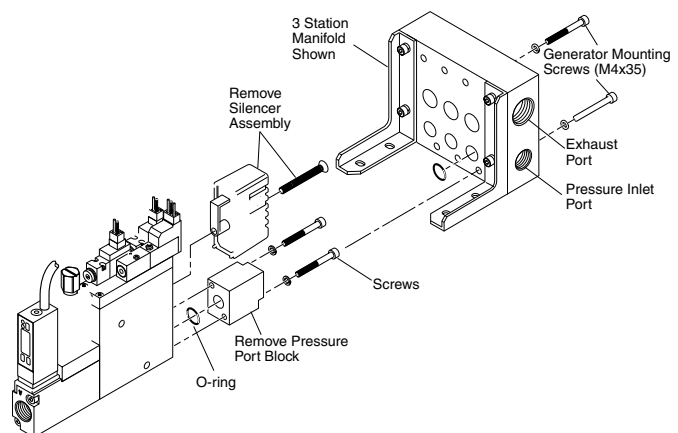

Replacement components

Item	Part number	Description
1	CVK-S	Silencer
2 thru 7	CVK-F	Filter kit
5	CVK-E	Filter element
8, 10	MC2-24-B-10-D	Blow-off Pilot Valve
9, 10	MC2-24-B-10-V	Air-Economizing Valve
10	MC2-5L	500mm clip lead
11,13	VA01PLC241PE	Vacuum on / off valve, NPN
12,13	PCL241B-NB-D24UM	Vacuum on / off valve, PNP
13	PCL2-D24-CL5	500mm clip lead
Item	Part number	Replacement sensor
14	MPS-V23C-NC	MPS-V23 (NPN) option
	MPS-V23C-PC	MPS-V23 (PNP) option

⚠ Cautions

Do not use or expose the CEK with fluids or corrosive gases. Vacuum Venturi's are designed to be used with non-lubricated, non-corrosive, compressed air.

Do not operate CEK generators outside the temperature range and pressures listed in the specifications section of this catalog. Regulate the compressed air to 70PSI and filtrate with a maximum 40 micron filter. Non-lubricated compressed air will maintain the life and vacuum level of the generator.

Check the insulation of all lead wires after installation to avoid shorts. Properly secure all lead wires to avoid stress or repeated movement that may fray lead wires.

Some electrical components are diode or zener diode protected. When installing solenoids and sensors, check the polarity of the component before applying power. Apply the appropriate voltage to the solenoids and sensors. Inappropriate voltage, shorts, or surges may damage the circuitry.

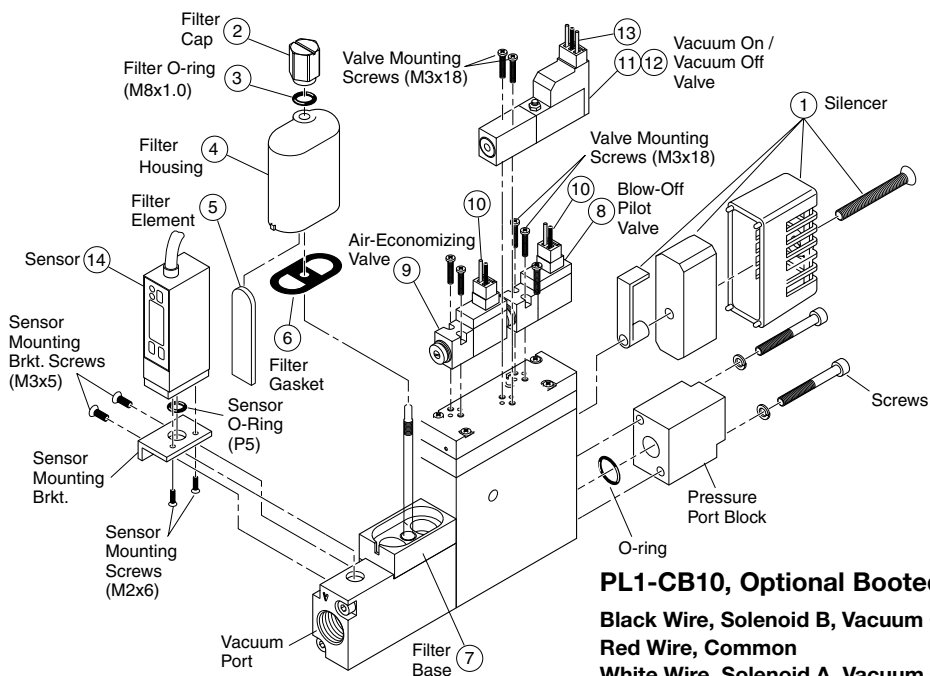

PL1-CB10, Optional Booted Cable

Black Wire, Solenoid B, Vacuum Off

Red Wire, Common

White Wire, Solenoid A, Vacuum On

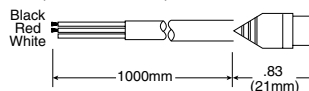

Pilot Valve Cable

MC2-5L (500mm) Lead*

(Connects Power Source to Vacuum & Blow-off Release Pilot Valves)

Positive "+" (Red Wire)
Negative "-" (Black Wire)

* Included with Generator

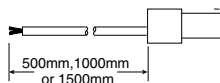

PCL2-D24-CL5* Cable

Black Wire, Solenoid B, Vacuum On
Red Wire, Common

Yellow Wire, Solenoid A, Vacuum Off

* Included with Generator

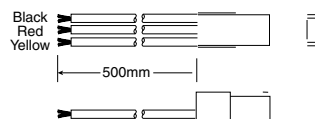

MC2-CB10 Valve Cable

(Connects Power Source to Vacuum & Blow-off Release Pilot Valves)

Positive "+" (Red Wire)
Negative "-" (Black Wire)

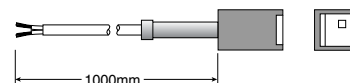

CEK - System logic

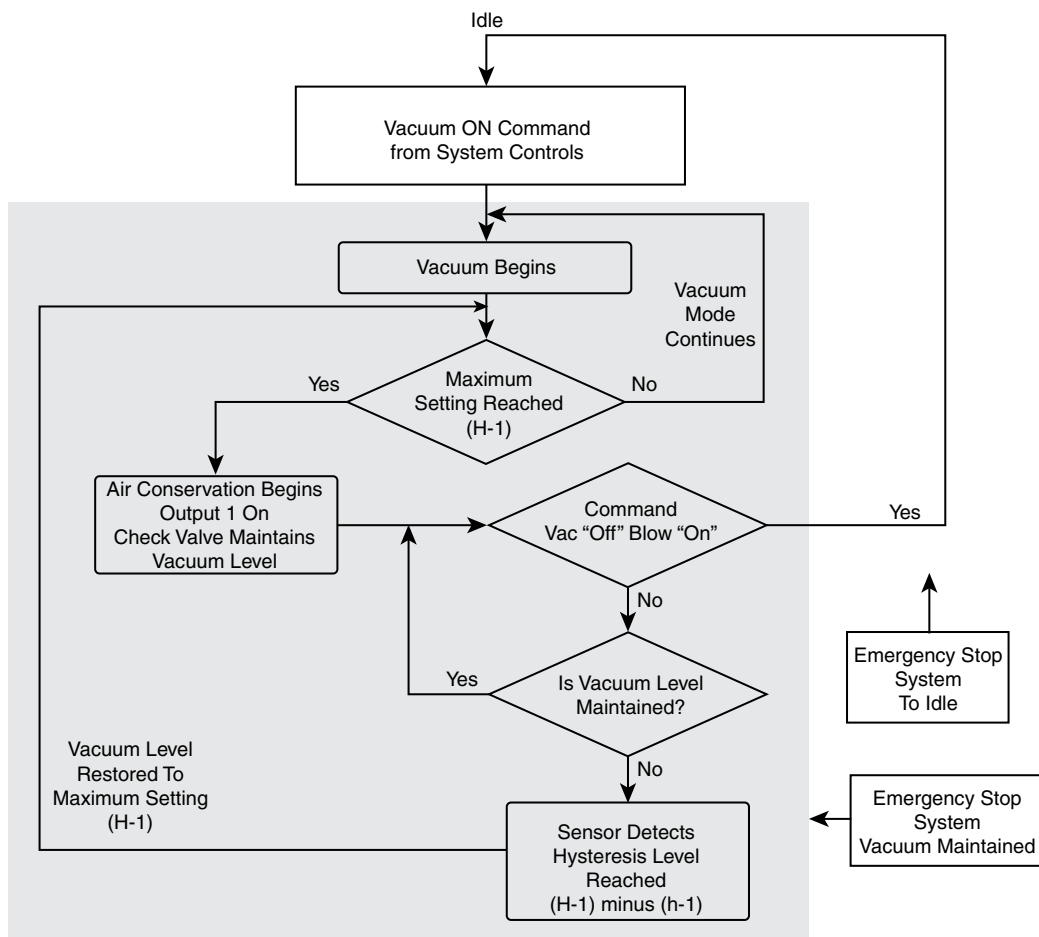



B

CEK - Emergency Stop Operating System (EOS)

The Emergency Stop Operating System is designed to maintain the last state of operation when an emergency stop or power failure occurs.

The chart below illustrates the state of operation in different modes.

Modes	Vacuum On	Vacuum Off	Blow-Off	EOS
Normal Conditions	Air-Economizing between 18-16 inHg	Idle	Blow-Off On Blow-Off Idle	EOS Off
Emergency Stop, Power Failure	Vacuum On	Idle	Blow-Off On or Idle	EOS On
				
Restore Power	Vacuum On Air-Economizing Function Resumes	Idle	Idle	EOS Off



The CVXCEK vacuum generator creates vacuum and blow-off pressure in a vacuum system and has additional Air-economizing and emergency operating system functions.

Each CVXCEK unit consists of 2 independent vacuum generators labeled channel 1 and channel 2. Each vacuum generator has a vacuum ON / OFF solenoid pilot valve, blow-off solenoid pilot valve, Air-Economizing valve, blow-off needle control valve, pressure sensor, vacuum check valve, vacuum filter, and exhaust filter. Each Vacuum Generator is mounted to a 2-Station bar manifold with an optional electrical mounting kit. The pressure provided to inlet port of the bar manifold is common to both vacuum generators.

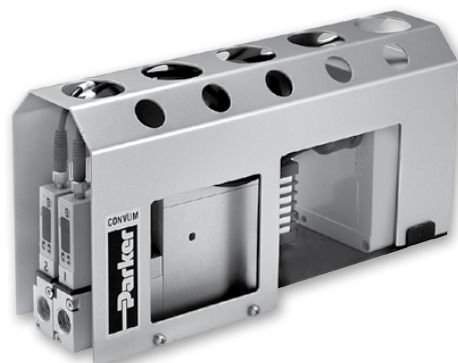

B

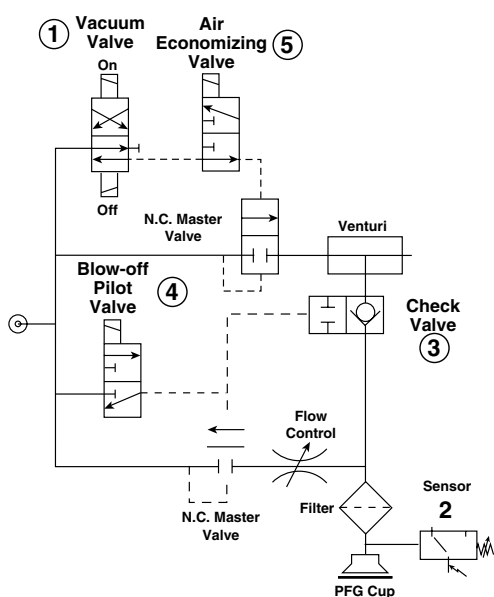

Features

- Integrated double solenoid for hold last state conditions
- Integrated vacuum pilot
- Integrated blow-off pilot
- Integrated filter, silencer
- Air economizing capabilities
- Manifolds for up to 5 units

General operation of CVXCEK vacuum units

A vacuum generator is a single stage Venturi that creates vacuum pressure using compressed air. In principle, compressed air is throttled as the air exits the nozzle and is discharged into the diffuser. This increased velocity of air lowers the pressure in the diffusion chamber. The volume of air within the closed vacuum system flows into the low-pressure area of the diffusion chamber and is exhausted thru the diffuser. This effect increases the vacuum level and evacuates most of the air within the closed vacuum. The vacuum generator will produce the specified degrees of vacuum as cataloged if the vacuum system is closed, inlet pressure is to design pressure, and there are no major restrictions in the exhaust flow.

Vacuum is created when the unit receives a momentary or maintained command vacuum "ON" signal, (high signal is sent to Vacuum Pilot Valve (1). Once a preset vacuum degree (H-1) of the pressure sensor (2) is achieved, the Air-Economizing Valve is enabled to conserve compressed air. The vacuum level will be maintained by the Check Valve (3) until the hysteresis switch point (H-1 minus h-1) of Sensor (2). At this point vacuum is turned back "ON" until the switch point (H-1) is achieved again. This cycle, which is called Air-economizing, will repeat until a blow-off signal is sent to the unit. When the Blow-off Pilot Valve (4) is activated to decay the vacuum pressure, the unit will release the part. Command vacuum "ON" should be turned "OFF" when command blow-off is turned "ON". The Emergency Stop operating system provides Air-Economizing or maximum degree of vacuum at the time of disruption of Input and Output Power.

Model Number Index

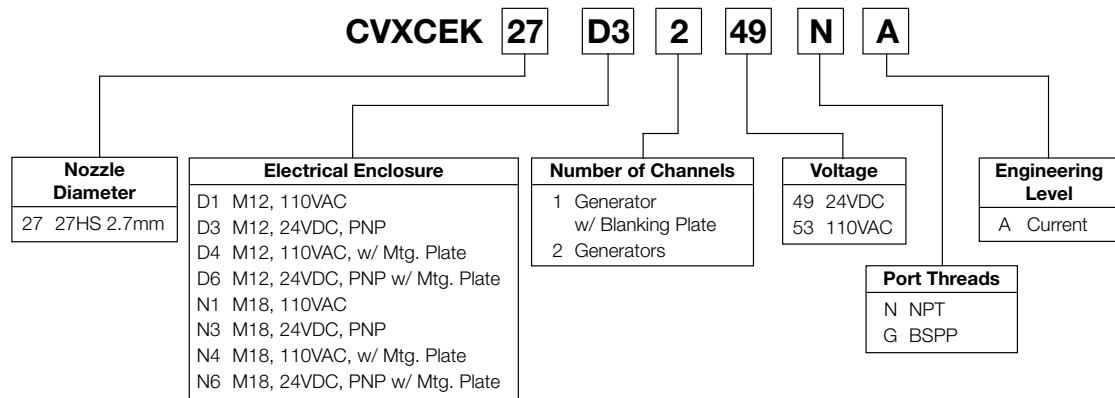

Specifications

Media	Non-lubricated compressed air, non-corrosive gases		
Operating pressure	4.8 bar (70 PSI)		
Humidity	35 to 85%		
Pressure port	G: 1/4 BSPP female, R: 1/4 BSPT female, N: 1/4 NPT female		
Vacuum port	G: 3/8 BSPP female, R: 3/8 BSPT female, N: 3/8 NPT female		
Operating temperature	5°C to 50°C		
Material	Aluminum, Brass, NBR		
Air-economizing valve and blow-off release pilot		Vacuum pilot valve	Sensors
Type of control	Single solenoid	Double solenoid	MPS-2 Pressure sensor
Manual operation	Manual override	Manual overrides	N/A
Electrical connection	Clip connector	Clip connector	M8, 4-pin
Power supply*	24VDC ± 10%	24VDC ± 10%	10.8 to 30VDC
Solenoid power consumption	0.6W with LED and surge	2.0W with LED and surge	125mA
Operating pressure	4.8 bar (70 PSI)	4.8 bar (70 PSI)	-1 to 5 bar (-14.7 to 72.5 PSI)
Air supply	Normally closed	Normally closed	N/A
Manifold weight	1-Station: 1758g, 2-Station: 2495g		

* 110VAC units use 24VDC solenoids and sensors.

Performance

Series / nozzle diameter	Nozzle diameter (mm)	Vacuum degree At 70 PSI (inHg)	Vacuum flow per channel l/mn	Air consumption per channel l/mn
CVXCEK27	2.7	27	160	295

Evacuation time

Series / nozzle diameter	Air supply pressure bar	Air consumption per channel l/mn	Evacuation time per channel in sec / ft³ * to reach different vacuum levels (inHg)								
			3	6	9	12	15	18	21	24	27
CVXCEK27	4.8	295	0.02	0.07	0.11	0.2	0.3	0.47	21.2	1.49	—

Vacuum flow (l/mn)

Nozzle Dia.	mbar										
	0	100	200	300	400	500	600	700	800	900	1000
27HS	162	144	125	106	88	70	50	32	14	—	—



Sensor output function

Sensor outputs are open collector transistor type. Replacement Sensor MPS-V2C-NC is an NPN Sinking Sensor. When installed on the CVXCEK, the onboard electronics converts this sensor to a PNP circuit. Wiring circuit of the CVXCEK units is PNP, Sourcing. Each vacuum generator sensor has 2 outputs. Output 1 and Output 2 are independent of each other and have different factory set conditions. These settings can be changed with the touch pad programming.

B Air economizing

Minimizes air consumption by utilizing the built in check valve. Once a predetermined vacuum level has been achieved (H-1), the Air-Economizing valve is enabled and the check valve maintains the vacuum level within the system. The Air-Economizing valve is disabled at a vacuum level H-1 minus h-1. The hysteresis feature of the vacuum sensor can maintain the vacuum level of the system indefinitely when properly wired to the Air-Economizing valve and operating pressure is present.

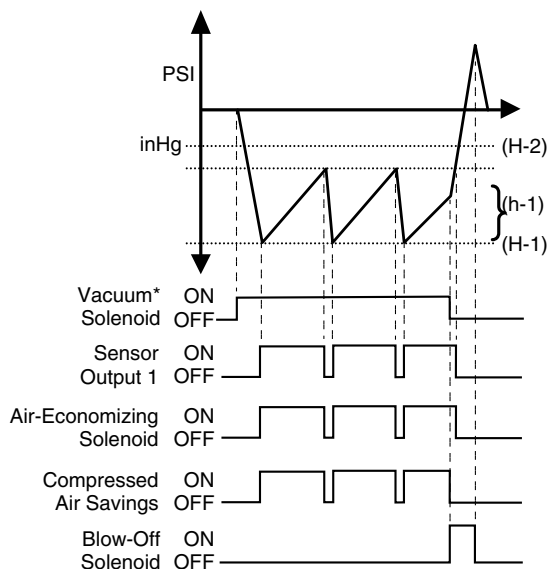

* Vacuum Solenoid can be a maintained or momentary signal. Maintained shown.

Sensor Output 1 - Air economizing

This sensor output does not interface with the input table of the PLC/PC. This sensor output interfaces with the Air-Economizing Valve on the CVXCEK Unit. The Vacuum Pilot Valve Solenoid is connected to the PLC/PC output table. The switch point setting, (H-1) on Output 1 of the sensor, enables the Air-Economizing Valve. No external PLC programming is required for Air-Economizing functions because this function is built into the CVXCEK Electrical Unit. The vacuum pilot signal from the vacuum ON/OFF valve is connected to the Air-Economizing Valve. It is this valve that toggles the vacuum pilot

signal to the Vacuum Poppet Valve on and off. The toggling of the vacuum pilot signal on and off creates the air-economizing mode. When the vacuum level in system achieves the preset valve of H-1, the sensor output switches to a Closed, Passing, state. This activates the Air-Economizing valve which inhibits the vacuum pilot signal from creating vacuum. In nonporous applications, the internal check valve maintains the vacuum level till the level drops through the Hysteresis Range (h-1) to the hysteresis switch point setting vacuum (H-1) minus (h-1). At this point, the sensor output switches to an open position, Non-passing state and de-activates the Air-Economizing Valve. This cycle will continue depending on the vacuum system and until blow-off function is enabled.

Sensor Output 2 - Vacuum confirmation - part presence signal

Operates as an Output from the Sensor to provide a Part Presence Signal. This sensor output interfaces with the Input table on the PLC/PC. When the cup is adhered to the part, vacuum level increases and at the Switch Point Setting (H-2), the sensor changes state to indicate a part presence signal.

Emergency stop condition

An emergency stop condition for factory automation is an external override condition that is usually activated by the machine operator to temporarily shut down the equipment. It is the Loss of Output Power or the Loss of Output Power and Input Power to the CVXCEK Vacuum Generator. The relevance to vacuum is the ability of the vacuum equipment to maintain the last output state of the control circuit.

The Emergency Operating System (EOS) on the CVXCEK unit is designed to maintain and continue the current operation mode of the vacuum generator. The detent Vacuum Pilot Valve will maintain the last command of the PLC/PC. The Air-Economizing Valve will still operate during loss of output power. The current operation mode of the vacuum generator will be maintained when operating pressure is present.

If an emergency event or power failure occurs any time the system is in the shaded area, vacuum will be maintained to hold the work piece. If an emergency event or power failure occurs any time the system operations are at idle or during blow-off "ON", the system will remain or return to the idle state.

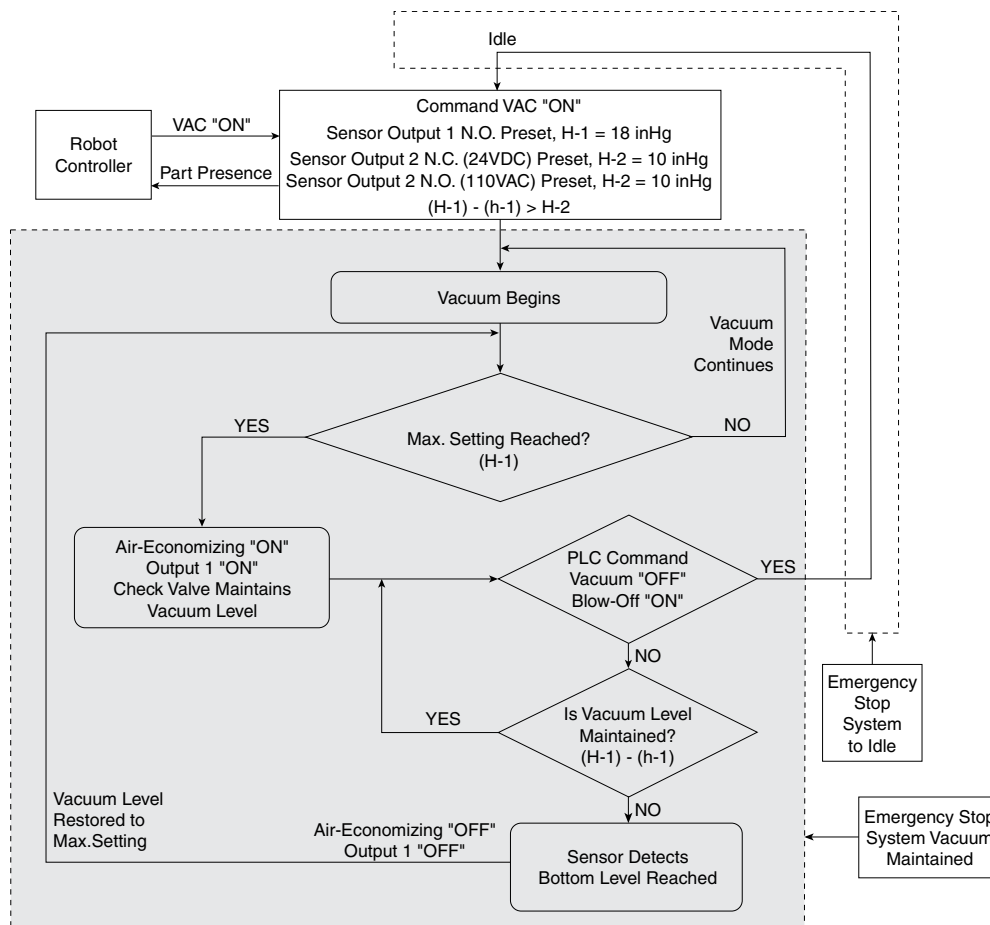

B

The Emergency Stop Operating System is designed to maintain the last state of operation when an emergency stop or power failure occurs.

The chart below illustrates the state of operation in different modes.

Modes	Vacuum on	Vacuum off	Blow-off	
Normal Conditions	Air economizing 600 to 520 mbar	Idle	Blow-off on	Blow-off idle
Emergency stop event				
Input power on Output power off	Air economizing 600 to 520 mbar	Idle	On ↓ Idle	Idle ↓ Idle
Input power off Output power on	Vacuum on ↓ Max. vacuum on	Idle	On ↓ Idle	Idle ↓ Idle
Input power off Output power off	Vacuum on ↓ Max. vacuum on	Idle	On ↓ Idle	Idle ↓ Idle
Restore power Input power on Output power on	Vacuum on ↓ Air economizing 600 to 520 mbar	Idle	Idle	

Dimensions

B

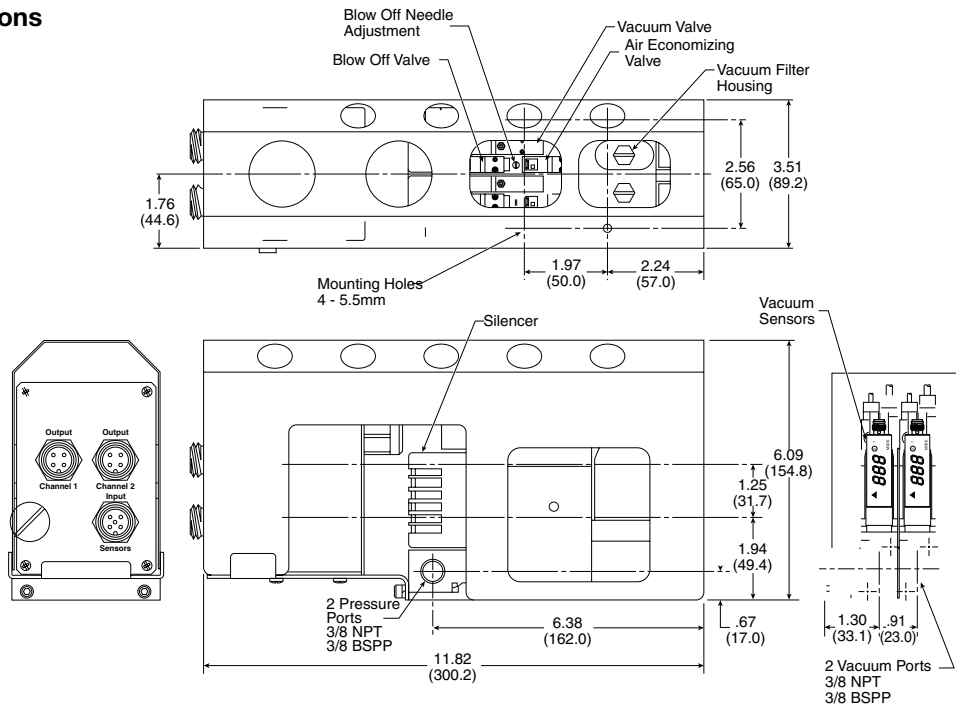

Optional mounting plate

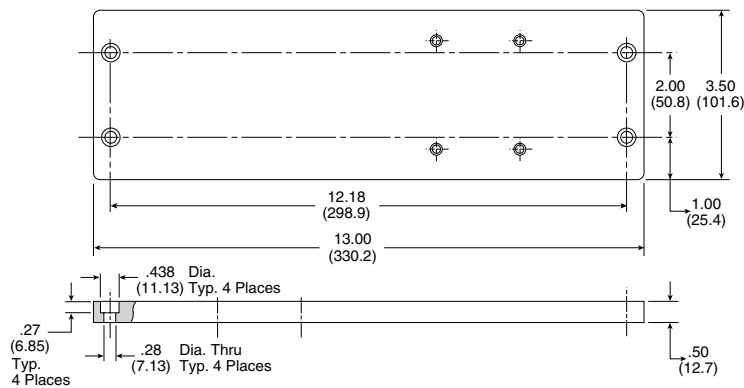

M12, 24VDC

Output - 4-Pin, M12, Keyed male

Input - 5-Pin, M12, Keyed male

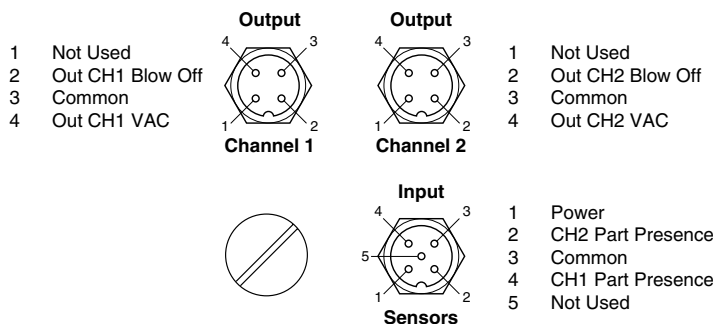

B

M12, 110VAC

Output - 4-Pin, M12, Double keyed male

Input - 5-Pin, M12, Double keyed male

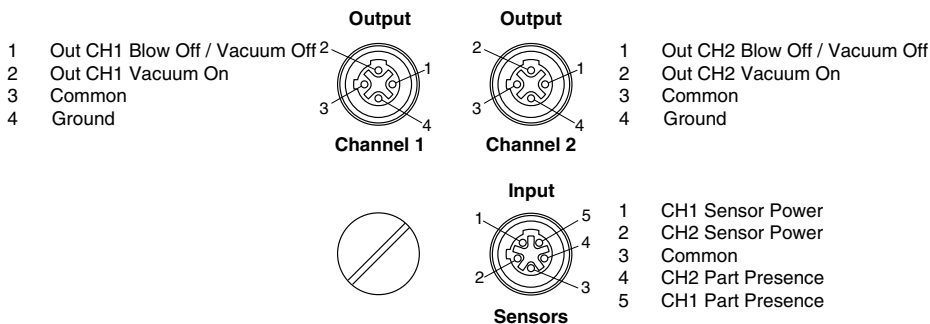

M18, 24VDC & 110VAC

18-Pin connector

24VDC

- A CH2 Blow Off
- B CH2 Sensor Power
- C CH2 Part Presence
- D CH2 VAC Control
- E CH1 Blow Off
- F CH1 Sensor Power
- G CH1 Part Presence
- H CH1 VAC Control
- J DC Voltage Monitor
- K Common
- L Ground
- M Not Used
- N Not Used
- P Output Power
- R Not Used
- S Not Used
- T Not Used
- U Not Used

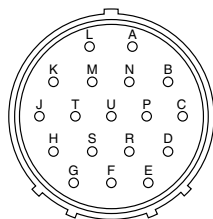

Face View - Male 18-Pin Connector

110VAC

- A CH2 Blow Off
- B CH2 Sensor Power
- C CH2 Part Presence
- D CH2 VAC Control
- E CH1 Blow Off
- F CH1 Sensor Power
- G CH1 Part Presence
- H CH1 VAC Control
- J AC Voltage Monitor
- K Common
- L Ground
- M Not Used
- N Not Used
- P Not Used
- R Not Used
- S Not Used
- T Output Power
- U Not Used

Notes: Pin B & F are jumpered inside unit.
Either pin can connect power to both sensors.

Pin P / T & J are jumpered inside unit.
This is for monitoring power only. Pin P / T is not necessary for operation of the unit.

Replacement components

Item	Part number	Description
1	CVK-S	Silencer
2 thru 7	CVK-F	Filter kit
5	CVK-E	Filter element
8	MC2-24-B-10-D	Blow-off pilot valve
9	MC2-24-A-10-V	Air-economizing valve
10	MC2-CB10	1000mm clip lead
11	PCL241B-NB-D24UM	Vacuum on / off valve, PNP
	VAO1PLC241PE	Vacuum on / off valve, NPN
12	PL1-CB10	1000mm clip lead
13	MPS-V2C-NC	Pressure sensor
14	CB-M8-4P-2M	4-Pin, M8, sensor cable
1 thru 9	CEK27HSZC24PBLN	CEK generator only
1 thru 9, 13	CEK27HS21C24PBLN	CEK generator & sensor

B

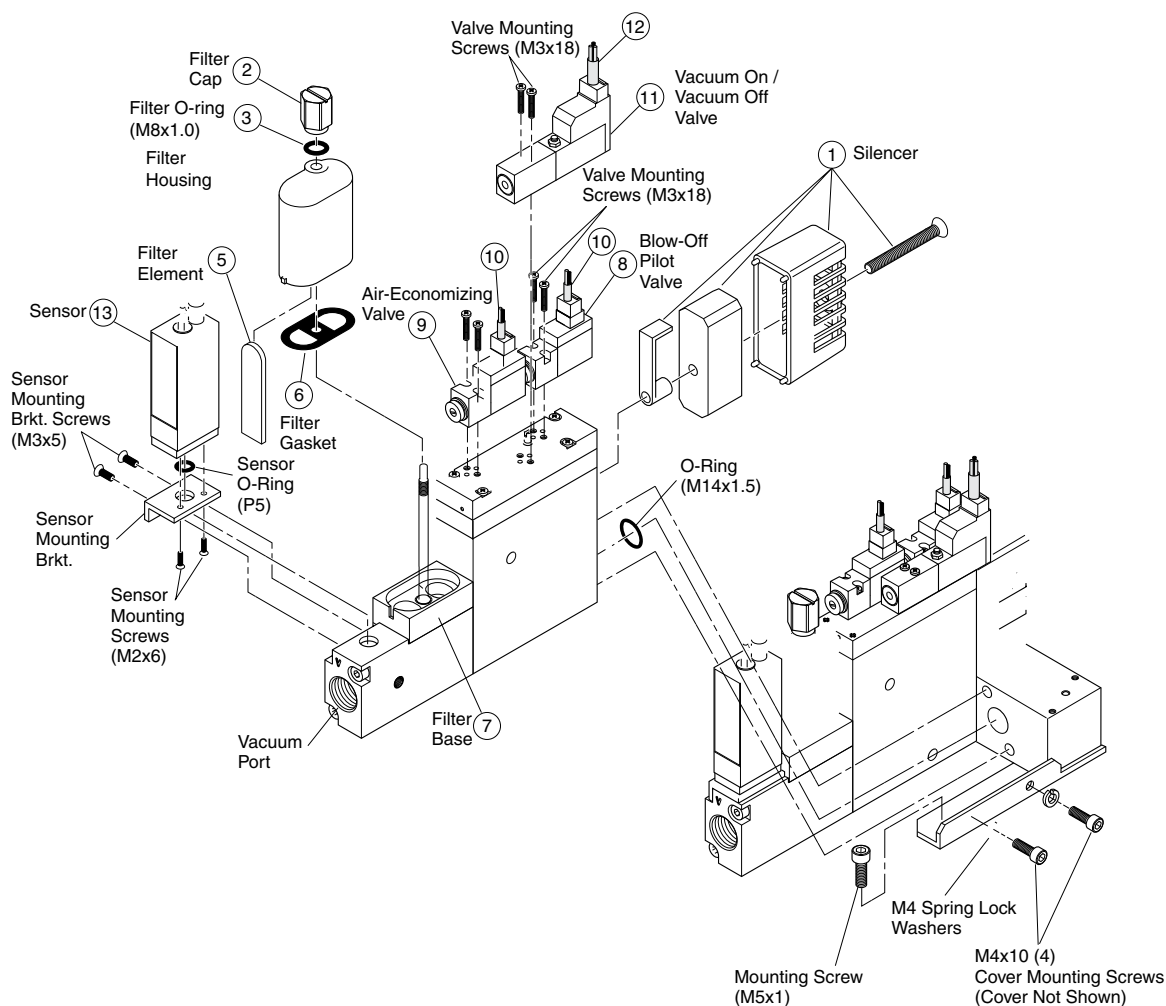

Discrete kits

- PSCEKD1A - M12, 110VAC**
- PSCEKN1A - M18, 110VAC**
- PSCEKN3A - M18, 24VDC**
- PSCEKD3A - M12, 24VDC**

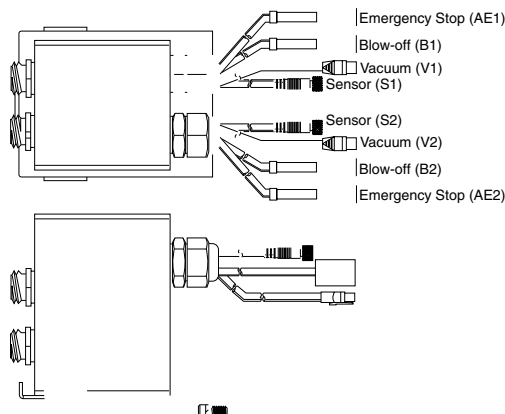
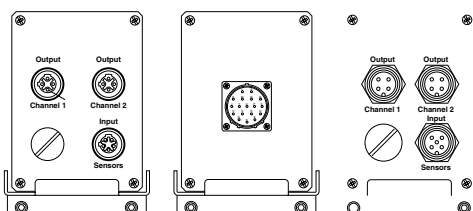

PL1-CB10, Valve cable

Black Wire, Solenoid B, vacuum off
 Red Wire, Common
 White Wire, Solenoid A, Vacuum on

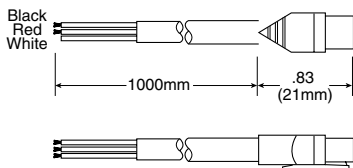

MC22-CB10 Valve Cable

(Connects Power Source to the Air-Economizing & Blow-off Release Pilot Valves)
 Positive "+" (Red Wire)
 Negative "-" (Black Wire)

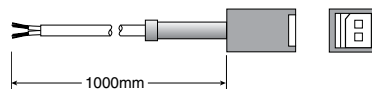

ENC244
 Cover

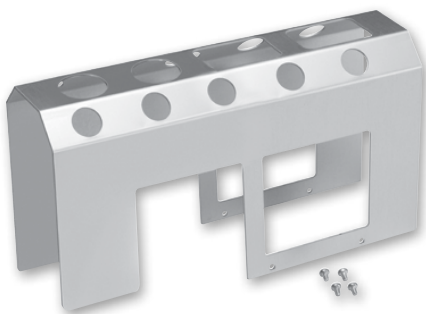

⚠ Cautions

Do not use or expose the CEK with fluids or corrosive gases. Vacuum Venturi's are designed to be used with non-lubricated, non-corrosive, compressed air.

Do not operate CEK generators outside the temperature range and pressures listed in the specifications section of this catalog. Regulate the compressed air to 70PSI and filtrate with a maximum 40 micron filter. Non-lubricated compressed air will maintain the life and vacuum level of the generator.

Check the insulation of all lead wires after installation to avoid shorts. Properly secure all lead wires to avoid stress or repeated movement that may fray lead wires.

Some electrical components are diode or zener diode protected. When installing solenoids and sensors, check the polarity of the component before applying power. Apply the appropriate voltage to the solenoids and sensors. Inappropriate voltage, shorts, or surges may damage the circuitry.

Features

- Pressure range:
Vacuum pressure: -1 to 0 bar
- Sensor output:
2 NPN or PNP open collector
Transistor output, 30VDC, 125mA
- Switch Point and Window Comparator Mode
- Selectable units of measure
- Output response time less than 2.0 milliseconds
- RoHS
- Air and non-corrosive gases
- Error message

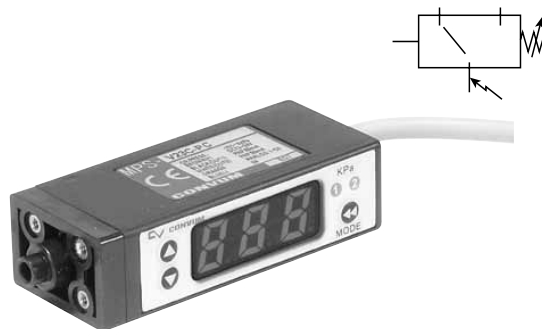

B

MPS-23 sensor only ordering numbers

Pressure range	Port thread	Electrical output	Electrical connection	Part number
-1 to 0 bar	Ejector mount	(2) PNP	M8 on 1 m cable, 4-Pin	MPS-V23C-PC
-1 to 0 bar	Ejector mount	(2) NPN	M8 on 1 m cable, 4-Pin	MPS-V23C-NC

MPS-23 Accessories

M8, 4-Pin, 2 meter cable	CB-M8-4P-2M-PUR
M8, 4-Pin, 5 meter cable	CB-M8-4P-5M-PUR

Sensor pin out

Pin

- 1 Brown: 24VDC
- 2 White: PNP/NPN Open Collector Output 2
- 3 Blue: 0VDC
- 4 Black: PNP/NPN Open Collector Output 1

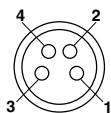

Programming options

Outputs change N.O. / N.C.	✓
Units of measure change	✓
Hysteresis mode	✓
Window comparator mode	✓
Auto teach mode	✓
Output response time	✓
Lockout option	—
Password lockout	✓
Max. value display	✓
Min. value display	✓
Zero reset	✓
Error output mode	✓

Internal circuit for open collector and analog output wiring

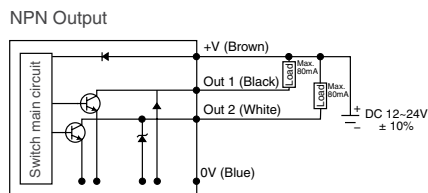
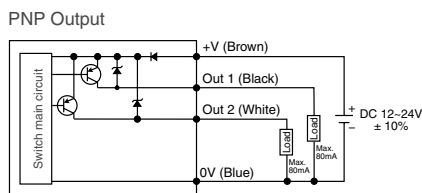

Specifications

Pressure range	-1 to 0 bar (-14.5 to 0 PSI)
Proof pressure	3 bar (44 PSI)
Display resolution, Units of measure	0.1, kPa
	0.001, kgf/cm ²
	0.001, bar
	0.01, PSI
	0.1, in-Hg
Media	1, mmHg
	0.1, mmH ₂ O
Pressure port	Generator mount only
Operating temperature	0 to 50°C
Storage temperature	-20 to 60°C
Humidity	40 - 85% RH (no condensation)
Electrical connection	(C) 4-pin, M8 connector on 1M lead wire
Power supply	12 to 24VDC ±10% or less, Ripple (Vp-p) 10% or less
Display	3 + 1/2 digit, 1 color, 7-segment RED LED
Display refresh	.1 to 3.0 Seconds, Variable (factory set at 0.1)
Control output	NPN (Sinking), PNP (Sourcing), Open collector, max 80mA, 2 output
Switch output	Output signal, NPN or PNP, Normally open or closed, LED indicator
Output indicator	Green LED (OUT1), Red LED (OUT2)
Output modes	Hysteresis or Window Comparator
Response time	≤ 2.5ms (chattering-proof function: 24ms, 192ms, 786ms selections)
Repeatability	± 0.2% of F.S. ± 1 digit or less
Thermal error	≤ ± 2% of F.S. or less at range of 0°C to 50°C
General protection	IP40, CE marked, EMC-EN61000-6-2: 2001
Current consumption	<55mA
Vibration resistance	10 to 150Hz, Double amplitude 1.5mm, XYZ, 2 hrs.
Shock resistance	980 m/s ² (about 10G), 3 times/each directions X, Y, Z
Noise resistance	Vp-p400V, 10 ms, 0.5µs noise simulator
Material	Housing: ABS (black) , Pressure port: Zinc die-cast, Diaphragm: Silicone
Mass	80g (including cable)

B

Dimensions

Generator mount

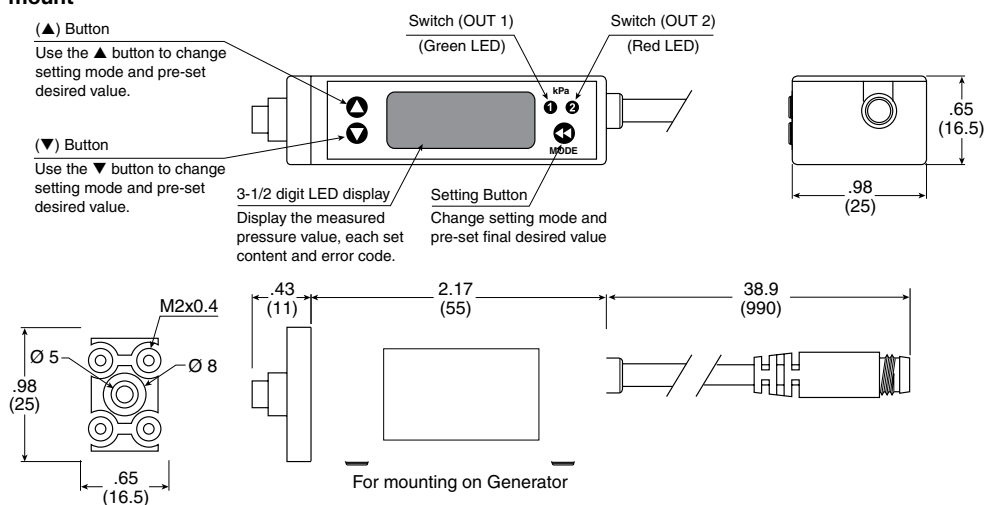

Initial setting mode

B

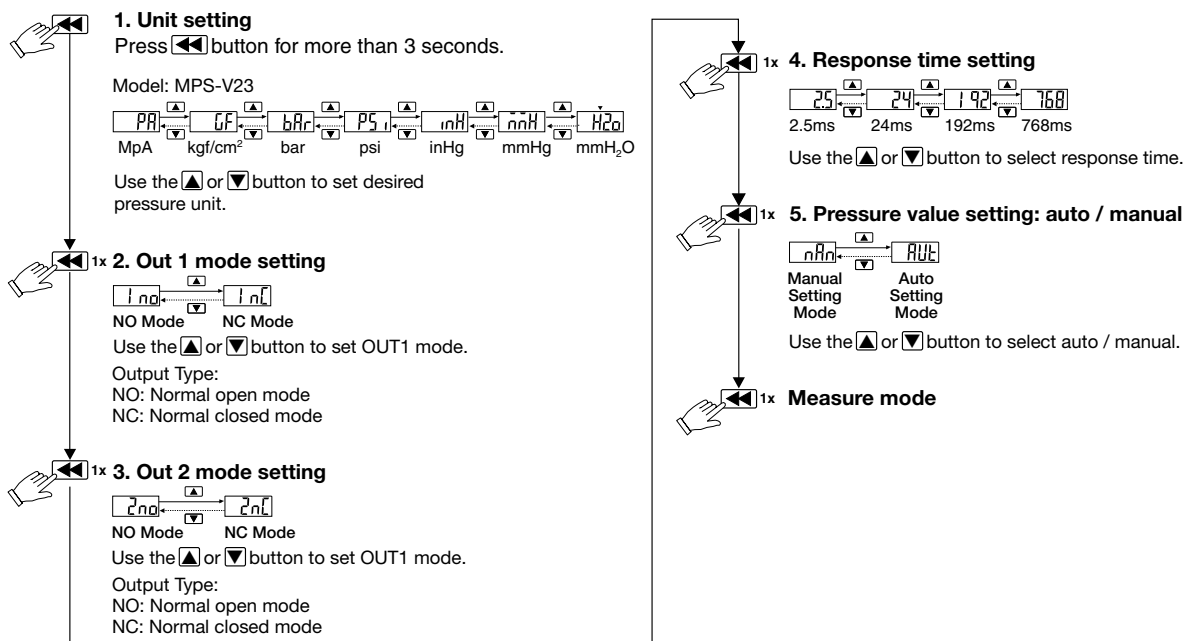

Zero point setting / the max. & min. display mode

Zero setting:

- press the button at the same time until the "00" is shown. Release the button to end zero setting.

The max. value display mode:

- Press button 2 seconds to enter the max. value mode, pressure sensor will detect the max. value and keep max. value displayed.
- Press button 2 seconds to return to measure mode display.

The min. value display mode:

- Press button 2 seconds to enter the min. value mode, pressure sensor will detect the min. value and keep min. value displayed.
- Press button 2 seconds to return to measure mode display.

Key lock / unlock mode

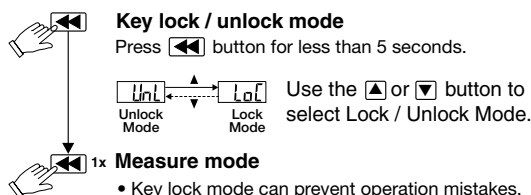

Output type

Hysteresis Mode $P1 (n1) > P2 (n2)$
 $P3 (n3) > P4 (n4)$
Output Hysteresis value can be preset.

Normal open mode

Vacuum (MPS-V23)

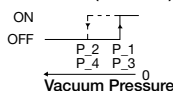

Normal close mode

Vacuum (MPS-V23)

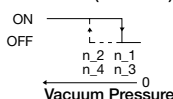

(Note)
When hysteresis mode setting is within 2 digits, if the input and pre-set pressure is quite near, pressure sensor output might cause chattering.

Window comparator Mode $P1 (n1) < P2 (n2)$
 $P3 (n3) < P4 (n4)$
Within pressure setting range, pressure sensor output can be ON or OFF.

Normal open mode

Vacuum (MPS-V23)

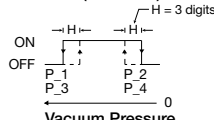

Normal close mode

Vacuum (MPS-V23)

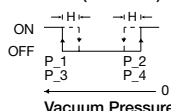

B

Manual setting mode

The LED shows: (P_*) at normal open mode and (n_*) at normal close mode. Pressure setting value is shown normally and will not lead to pressure sensor pause or stop working.

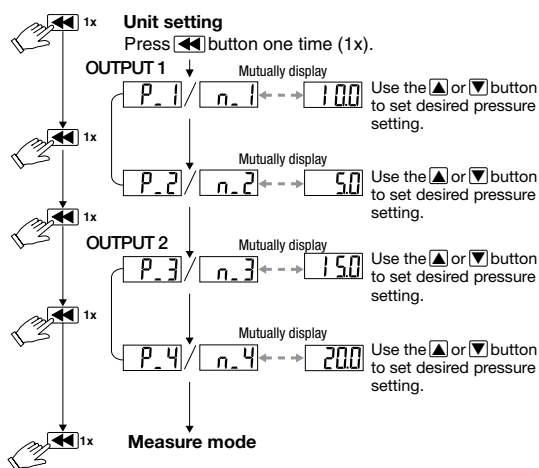

Auto setting mode

- *1. In case of without need of OUT1 pressure value setting, press $\nabla + \blacktriangle$ at the same time to enter (AP2) / (An2).
- *2. In case of without need of OUT2 pressure value setting, press $\nabla + \blacktriangle$ at the same time to enter measure mode.
- *3. The LED shows (AP*) at normal open mode and (An*) at normal closed mode.

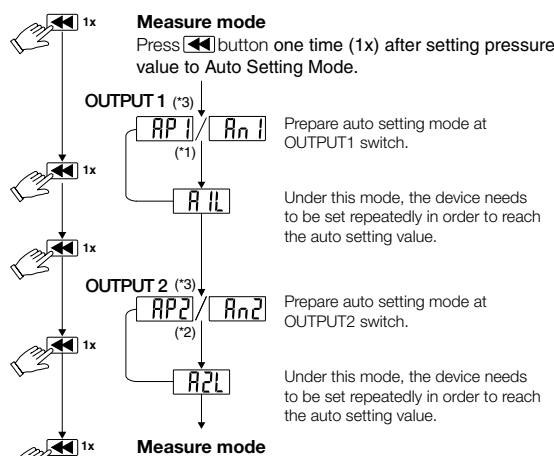

Calculation of setting value

A = The max. pressure value under auto setting mode.
B = The min. pressure value under auto setting mode.

$P1 (n1) = A \cdot \frac{A-B}{4}$
$P3 (n3) = B \cdot \frac{A-B}{4}$
$P2 (n2) = B \cdot \frac{A-B}{4}$
$P4 (n4) = A \cdot \frac{A-B}{4}$

Error messages

Error name	Display	Description	Solutions
Excess load current error	OUT1	Excess load current of 80 mA	Turn off power and check the cause of overload current or lower the current load under 80 mA, then restart
	OUT2		
Residual pressure error	Er3	During zero reset, ambient pressure is over $\pm 3\%$ F.S.	Change input pressure to ambient pressure and perform zero reset again
Applied pressure error	---	The applied pressure is excess the upper limit of pressure setting	Adjust the pressure within applied pressure range
	----	The applied pressure is excess the lower limit of pressure setting	
System Error	Er4	Internal data error	Turn power off and then restart. If error condition remains, please return to factory for inspection
	Er6	Internal system error	
	Er7	Internal data error	

B

The MVS-201 is a winning combination with the MC2, CVR-2, and CVK vacuum generators. The MVS-201 automatically provides an output signal for the blow-off function without the need of an additional output from the PLC. Begin the vacuum cycle with an output signal from the PLC to the "201" sensor. The "201" sensor has one NPN or PNP output for vacuum confirmation and a control output that interfaces directly with the blow-off release pilot valve. With programmable time control features and a special chip driver, the sensor automatically activates the blow-off release when the NPN or PNP vacuum signal from the PLC is discontinued. This eliminates, THE PREVIOUSLY REQUIRED, PLC output to activate the blow-off release. This technology eliminates PLC output requirements by 50% and reduces installation to a simple 4 wire system by wiring the sensor only. There are 3 modes of operation for various applications. The output response time of the sensor is less than 2.5 msec. Peak limit prevention maintenance feature is automatically recorded internally.

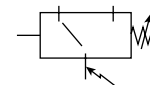

For use with MC22 / MC72 generators

Features

- Time controlled sensor
- Intelligent simple 4-wire system
- Eliminate I/O for release valve
- 2 functions with one rung of code
- Automatic timer (0-9.9 Sec.) function by sensor control driver for vacuum generating and release valves
- Peak value preventative maintenance confirmation
- Response time less than 2 milliseconds

Programming options

Outputs change N.O. / N.C.	✓
Units of measure change	✓
Hysteresis mode	✓
Lockout option	✓
Zero reset	✓
Energy savings mode	✓
Air conservation / blow-off timer	✓
Vacuum timer option	✓
Signal controlled vacuum	✓
Blow-off activation timer	✓
Blow-off timer	✓
Vacuum confirmation signal	✓
Blow-off confirmation signal	✓
Peak vacuum error message	✓
Vacuum response error message	✓
Blow-off time error message	✓

Basic PLC System

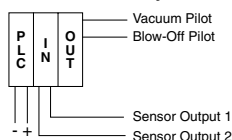

PLC System with 201 Sensor

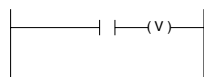
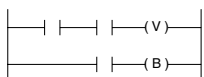
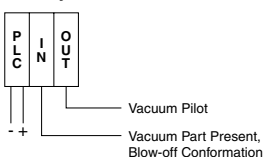

MVS-201 Ordering numbers

Pressure range	Output circuit	Input circuit	Electrical connector *	Part number
-1 to 5 bar	PNP sourcing	PNP sourcing	4 Pin, M8	MVS-201-PCP
	NPN sinking	NPN sinking		MVS-201-NC

* Requires sensor to valve electrical connector

Note:

Output Circuit provides vacuum and blow-off confirmation signal (Input Signal to PLC).
Input Circuit controls vacuum solenoid valve (Output Signal from PLC).

Sensor to valve electrical connector

Generator series	Sensor connection	Valve connection	Part number
MC22	5 Pin Clip Type	2 with clip type	MC22-C201G
MC72		2 wire leads	CVK-D201G



Specifications

Pressure range	Compound pressure: -1 to 5 bar (-14.7 to 72.5 PSI)
Units of measure	bar: 0.01
Display resolution	kPa: 1 kgf/cm ² : 0.01 PSI: 0.1
Media	Non-lubricated air and non-corrosive gases
Proof pressure	8 bar (116 PSI)
Operating temperature	0°C to 50°C
Storage temperature	-10°C to 60°C
Humidity	35 to 85% RH
Electrical connection	(C) 4-Pin, M8 connector
Power supply	10.8 to 30VDC, Ripple Vp-p 10% Max., Reverse voltage protection
Display	3-Digit, 7-Segment LED
Display frequency	5Hz
Circuit	NPN (Sinking), PNP (Sourcing) open collector transistor
Digital output	Individually selectable N.O. or N.C., max 125mA, 30V, with overcurrent protection
Mode	OP1, OP2, OP3 hysteresis: 0 to 100% of switch point
Response time	< 2ms
Repeatability	± 0.3% F.S.
Thermal error	±0.2% F.S. in temperature range: 0°C to 50°C
General protection	IP40, CE marked, EMC-EN55011 Class B, EN50082-1
Current consumption	< 45mA, < 25mA when utilizing screen saver option
Spike protection	350 Vp, 1, μs
Dielectric strength	1000 VAC 1 min.
Insulation resistance	> 100M ohms at 500VDC
Vibration resistance	10 to 55Hz, 1.5mm, XYZ, 2 hrs.
Shock resistance	10 G, XYZ
Material	Body: Polycarbonate
Mass	45g

B

Dimensions M8, 4-Pin

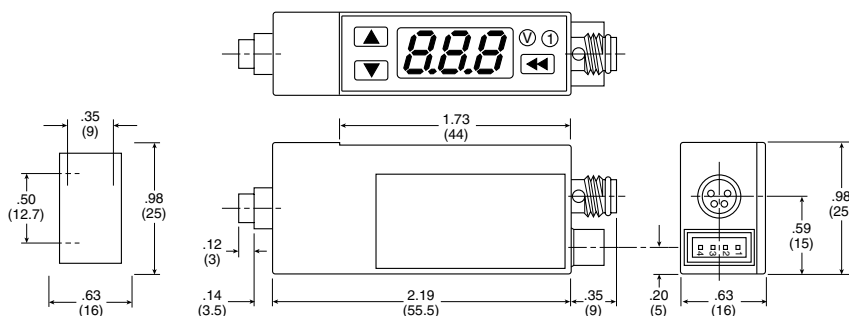

Operating modes

B

Mode: OP1 "Air Conservation / Timer"

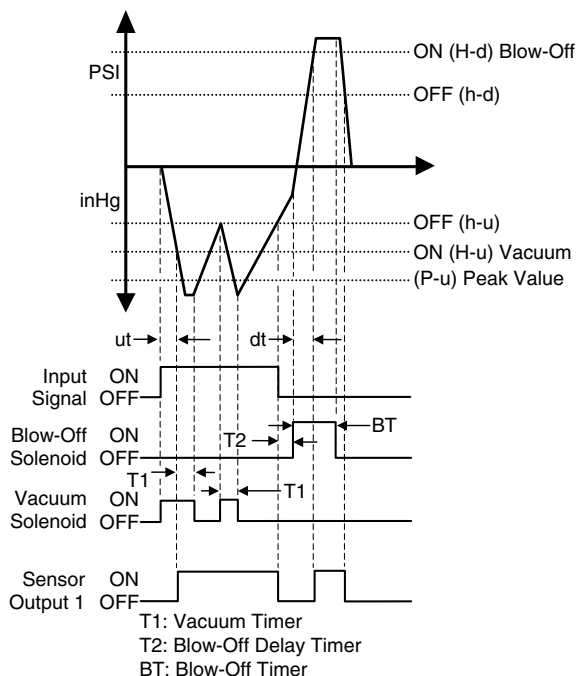

Mode: OP2 "Vacuum Timer Option"

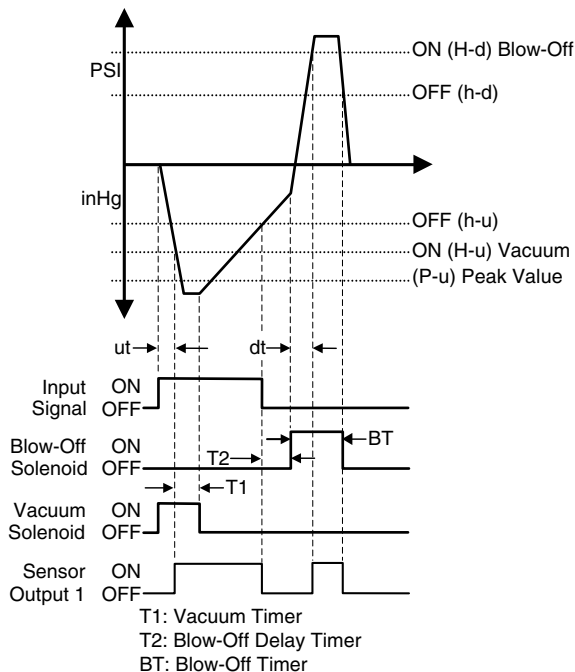

Timer mode OP1

"Air conservation / Vacuum valve timer"

This Vacuum valve control with the use of timing features conserves air consumption via the vacuum generator non-return check valve and sensor hysteresis function. Vacuum time (**t1**) can be used to control the vacuum valve for a specific length of time (0.0-9.9 sec.) after output 1 vacuum level is reached. The vacuum timing function (**t1**) will remove the signal from the sensor to the vacuum valve allowing the generator check valve system to conserve air consumption and vacuum. The vacuum valve will re-open for the same length of time (**t1**) when the pressure level drops to the hysteresis setting (**h-v**). The operation will continue until the input signal is stopped. Optional delay timer between vacuum / blow-off (**t2**) and blow-off (**bt**) timer is available. After selecting **OP1**, set **bt**, **t1**, and **t2** values by using arrow "UP" and "DOWN" keys. To bypass any of these timing function operations, simply enter 0.00 seconds and the sensor will automatically proceed to the next function.

Timer mode OP2

"Vacuum valve timer"

This mode is ideal for use with CONVUM generators without check valves. Vacuum timer (**t1**) can be used to control the vacuum for a specific length of time (0.00 – 9.9sec.) after output 1 is reached. Optional delay timer between vacuum / blow-off (**t2**) and blow-off (**bt**) timer is available. After selecting **OP2**, set **bt**, **t1**, and **t2** values by using arrow "UP" and "DOWN" keys. To bypass any of these timing function operations, simply enter 0.00 seconds and the sensor will automatically proceed to the next function.

Note:
Output Circuit provides vacuum and blow-off confirmation signal (Input Signal to PLC).
Input Circuit controls vacuum solenoid valve (Output Signal from PLC).

Operating modes

Mode: OP3 "Signal Controlled Vacuum"

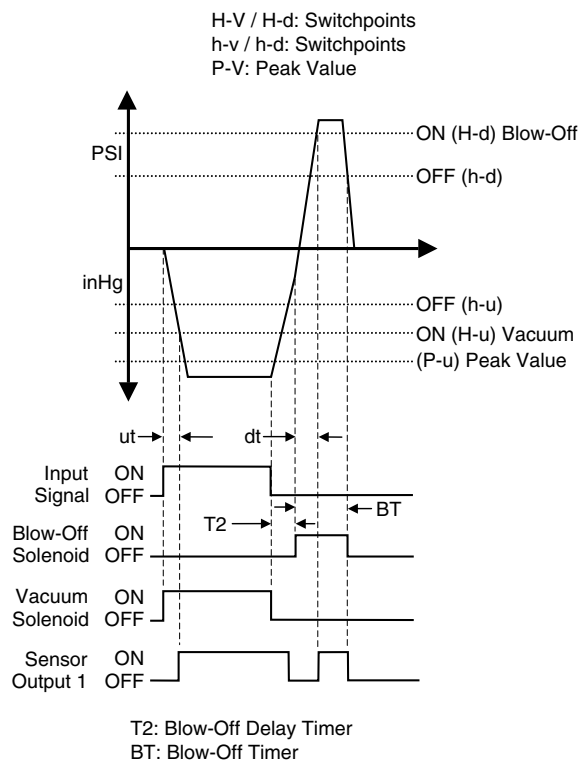

Timer mode OP3

"Signal controlled vacuum"

The vacuum timer option (**t1**) is omitted and the PLC controls the input signal time for the vacuum operation. The delay timer between vacuum / blow-off (**t2**) and the blow-off (**bt**) timers are still available. After selecting **OP3**, set **bt** and **t2** values by using arrow "UP" and "DOWN" keys. To bypass any of these timing function operations, simply enter 0.00 seconds and the sensor will automatically proceed to the next function.

Note:

Output Circuit provides vacuum and blow-off confirmation signal (Input Signal to PLC).
Input Circuit controls vacuum solenoid valve (Output Signal from PLC).

Additional sensor features

(Available in all operating modes)

Screen saver function

This reduces current consumption by 20mA and will activate after 10 seconds.

Peak value level (P-v)



The sensor records this value for preventative maintenance issues. If this value is not reached the sensor will display an error message (**ALP**) indicating leaks or wear in the system.

Vacuum level response time (ut)

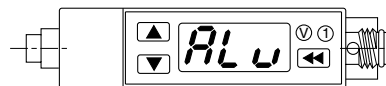

The sensor records the time (sec) to reach Output 1 and will display an error message (**ALu**) indicating Output 1 has not been reached within the acceptable time (sec) set by the user.

Blow-off time (dt)

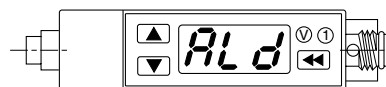

The sensor records the time (sec) to complete blow-off cycle and will display an error message (**ALd**) indicating (dt) has not reacting within the acceptable time (sec) set by the user.

B

Wiring diagram

M8 Pin

- 1 Brown: 24VDC
- 2 White: Input; NPN (0VDC) / PNP (24VDC)
- 3 Blue: 0VDC
- 4 Black: Output; NPN / PNP Open Collector Output

201 Pin

- 1 Red: Vacuum Solenoid Valve + V
- 2 Black: Gnd
- 3 Red: Blow-Off Solenoid Valve + V
- 4 Black: Gnd

Sensor male pin out

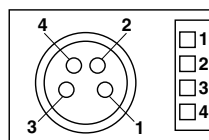

B

Internal circuit

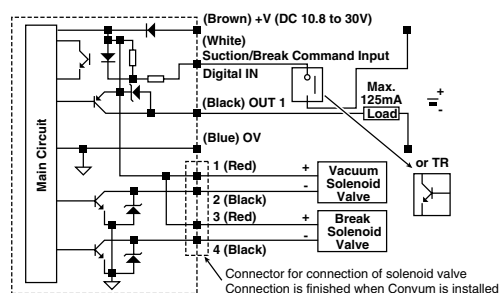
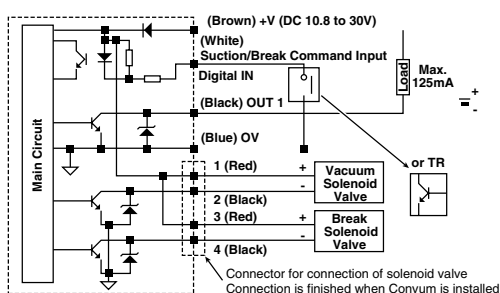

Output / Input NPN sinking

Output / Input PNP sourcing

⚠ Cautions

The MVS-201 Pressure Sensor is designed to monitor pressure and is not a safety measure to prevent accidents.

The compatibility of the sensor is the responsibility of the designer of the system and specifications.

Operating environment

- Parker Sensors have not been investigated for explosion-proof construction in hazardous environments.
- Do not use with flammable gases, liquids, or in hazardous environments.
- Avoid installing the sensor in locations where excessive voltage surges could damage or affect the performance of the sensor.

Operations

- Dedicate a power supply of 10.8 to 30VDC to the sensor and set the ripple to Vp-p10% or less. Avoid excessive voltage. Avoid voltage surges.
- A small amount of internal voltage drop is possible. Ensure the power supply minus any internal voltage drop exceeds the operating load.
- Verify the operating media is compatible with the specified sensor. Check the chemical make-up, operating temperatures, and maximum pressure ranges of the system before installing.
- Installation of air dryer system is recommended to remove moisture.

Installation

- Never insert an object into the pressure port other than an appropriate fluid connector.
- Avoid short-circuiting the sensor. Connect the brown lead to V+ and blue lead to 0V.
- Do not connect the output lead wires (black / white) to the power supply.
- Outputs not being used should be trimmed and insulated.

Error messages

Display	Description	Solutions
<i>Err</i>	Zero reset error	Reset zero below 3% of F.S.
<i>Er1</i>	System error (Internal)	Contact factory
<i>CE1</i>	Over current of Output 1	Load current exceeds maximum 125mA.
<i>FFF</i> <i>-FF</i>	Applied pressure exceeds pressure range	Apply pressures within the rating of the sensor

1 Press **1** x

Operating Mode 1

oP1, oP2, oP3

bt → 200, 999, 000

t1 → 030, 300, 000

t2 → 000, 999, 000

End

Operating Mode 2

oP2, oP3, oP1

bt → 200, 999, 000

t1 → 030, 300, 000

t2 → 000, 999, 000

End

Operating Mode 3

oP3, oP2, oP1

bt → 999, 000

t2 → 999, 000

End

2 Switch Output

H-u → 46, 0, 100

h-u → 7, 0, 100

H-d → 000

h-d → 000

End

3 Outmode Open or Closed

ou1 → no, nc

ouu → no, nc

oud → no, nc

Ed9 → Lo, Hi

PR, bR, F9, PS

End

Note: Ed9 setting
Set to Lo for NPN
Output Circuit or Hi for
PNP Output Circuit.

4 Screen Saver
Peak Vacuum Level
Vacuum Level Response Time
Blow-off Time

SdU → off, on

P-u → off, on, 0, off

ut → off, on, 999, off

dt → off, on, 999, off

End

5 Hold **Loc** Press **UnL**

Lock → Unlock

B

Programming symbols legend

oP1	Operation 1: Air Conservation / Timer	ALd	Error Message - Blow-off Time
oP2	Operation 2: Vacuum Timer Option	ou1	Output 1
oP3	Operation 3: Signal Controlled Vacuum	ouu	Vacuum Valve (Leave NO)
bt	Blow-Off Timer	oud	Blow-off Release Valve (Leave NO)
t1	Controlled Vacuum Signal with Timer	SdU	Screen Saver Function
t2	Blow-Off Activation Timer	P-u	Peak Vacuum Level Recorder (P-v)
Hu	Switch Output Value (H-v)	ut	Vacuum Response Time Recorder
hu	Switch Output Hysteresis Value (h-v)	dt	Blow-Off Time Recorder
Hd	Blow-off Output Value (H-d)	no	Normally Open
hd	Blow-off Output Hysteresis Value (h-d)	nc	Normally Closed
ALP	Error Message - Peak Vacuum Level	Ed9	Low or High Signal to Vacuum Valve
ALu	Error Message - Vacuum Response Time		

PDE2654TCUK
Vacuum Products

Generator Accessories
FSV Series – M5, G1, G2 & G3

Maintaining an acceptable level of vacuum is critical to the performance of vacuum systems that have a single source vacuum generator with multiple cups. The Parker Flow Sensing Valve assists in maintaining an acceptable vacuum level if the vacuum cup does not make a proper seal. The valve will automatically close if the cup loses the seal with the product during a pick and place motion.

B

The Parker Flow Sensing Valve is a normally open valve that switches to a closed metered state when the vacuum flow rate from the cup side to the generator side is greater than the switching flow rate of the flow sensing valve. The Flow Sensing Valve “Checks” the vacuum flow. The vacuum flow rate of the generator must be more than the switching flow rate of the Flow Sensing Valve or it will not switch to a “Checked” position. When using multiple Flow Sensing Valves per generator, the flow rate of the generator must be more than the combined switching flow rates of the flow valves and any other leak path. For example, a CV20-HSN has a maximum flow rate of 110 l/mn and a 1/8 Flow Sensing Valve has a switching flow rate of 8 l/mn. Therefore 13 Flow Sensing Valves can be connected in parallel to a CV20-HSN.

Once a Flow Sensing Valve is “Checked”, a small amount of by-pass flow occurs. This leakage allows a generator to be turned on prior to the cup being in place on a product and is the flow path used to evacuate the cup volume. The by-pass flow will decrease the maximum degree of vacuum in a system, and is considered a leak path when the cup is not sealed on a product. Blow off functions will still operate by forcing the Flow Sensing Valve to a full open position, allowing the part to be blown off.

Features

- Pick and place randomly placed products
- Minimize vacuum loss when cup seal is lost
- Direct mounting to cups
- 1/8 to G3/8 connection
- Integrated bronze filter

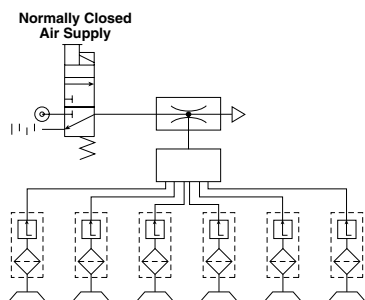

Ordering information

Description	Part number
1/8" BSPP	FSV-G1
1/4" BSPP	FSV-G2
3/8" BSPP	FSV-G3

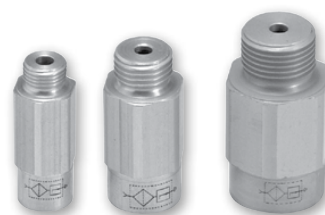

Operation

When the flow of air from the cup side to the generator side is greater than the switching flow rate of the valve, the float is drawn back against the spring and seals on the housing. In this state, flow passes through an orifice on the float. Vacuum flow is “Checked”. (See Figure 1).

When the cup comes in contact and seals on a product, flow is reduced and the spring forces the float towards the cup side inlet. This breaks the seal at the float and the full open state is restored. (See Figure 2).

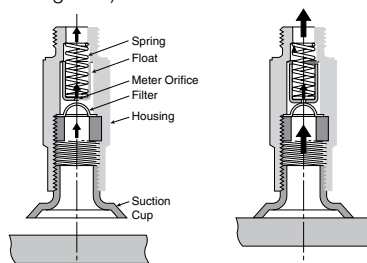
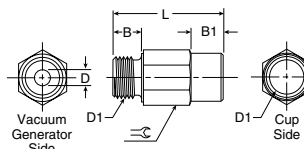

Figure 1
 (Closed, Metered Flow)

Figure 2
 (Open, Full Flow)

Specifications

Description	FSV-G1	FSV-G2	FSV-G3
Switching flow rate	8 l/mn		25 l/mn
Nominal size	4mm		
Housing material	Anodized aluminum		
Filter material	Al-Niro mesh		
Temperature range	-10° C to 60° C		
Maximum pressure	10 bar (145 PSI)		8 bar (115 PSI)
Media	Atmospheric air		
Weight (grams)	9	16	29



Dimensions (mm)

	B	B1	D	D1	L	⌀
FSV-G1	6.5	11	4	G	36	13
FSV-G2	8.5	11	4	G1/4	38	17
FSV-G3	12	13	4	G3/8	42	22



The CH Check valve is used to hold a degree of vacuum downstream from the check valve when the vacuum generator upstream from the check valve is turned off. A separate blow-off connection downstream from the CH check valve is required to destroy the vacuum pressure and blow off the part. This check valve is an open or passing flow path when there is a differential pressure from the pad side to the generator side.

Features

- Poppet design
- Low leakage
- Low cracking pressure

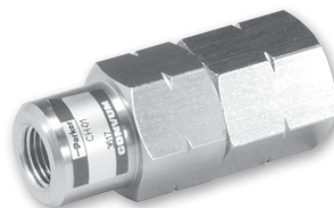

B

Normally Closed Air Supply with Blow-off & Optional Sensor

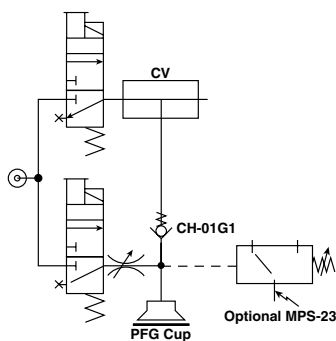

Specifications

Temperature range	0°C to 60°C
Operating vacuum	-0.3 to -0.96 bar (-4.25 to -13.89 PSI)
Port size	Pad side = 1/4", Generator side = 1/8"
Leakage rate	10 mbar / mn (0.2 PSI / mn)
Cracking pressure	0.2 bar (2.9 PSI)

Materials

Valve body / Fittings	Brass / Aluminum
Seals	BUNA
Spring	SUS

Ordering information

Description	Part number
BSPP Ports	CH-01G1
NPT Ports	CH-01N1

Dimensions

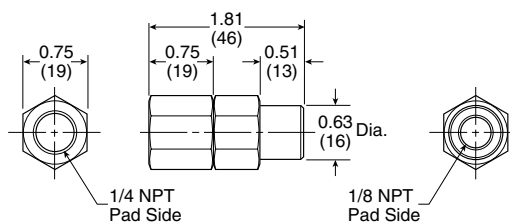

Always filtrate the vacuum system to protect the components from damaging particles absorbed from the environment. Elements should be replaced periodically to prevent slower response and overall performance of the system.



B

Specifications

Media	Non-corrosive air
Operating vacuum	0 to 0.95 bar
Maximum pressure	4 bar (60 PSI)
Operating temperature	0°C to 60°C
Filtration	120 µm (VF-2); 130 µm (VFL-44, 66, 88, VF-3, VF-5, VF-6)

Materials

Part number	Material housing	Material element	Weight (g)
VF-2G	Aluminum	Acrylic, Stainless steel	44
VF-3G	Aluminum	PC, Polyvinyl	88
VF-5G	Aluminum	PC, Polyvinyl	146
VF-6G	Aluminum	PC, Polyvinyl	234
VFL-44	Poly-carbonate	PC, Polyvinyl	19
VFL-66	Poly-carbonate	PC, Polyvinyl	21
VFL-88	Poly-carbonate	PC, Polyvinyl	23

Ordering information

Application	Male connection	Replacement elements	Replacement cover, o-ring	Part number
CV-05, CV-10	G1/8"	VF-2E	—	VF-2G
CV-05, CV-10	G1/8"	VF-3E	VF-3K	VF-3G
CV-15, MCA-10/13	G1/4"	VF-5E	VF-3K	VF-5G
CV-20/25/30	G3/8"	VF-6E	VF-3K	VF-6G
General use	4mm - Tube	VFL-E	VFL-44K	VFL-44
General use	6mm - Tube	VFL-E	VFL-66K	VFL-66
General use	8mm - Tube	VFL-88E	VFL-88K	VFL-88

Dimensions

VFL Series

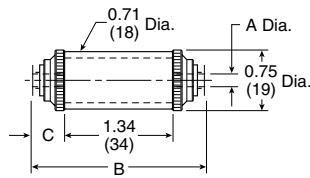

Part number	A	B	C
VFL-44	4	55	10.5
VFL-66	6	58	12
VFL-88	8	62	14

VF-5

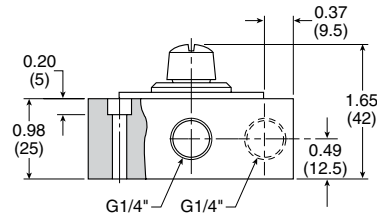

VFL-46H Mtg. Bracket

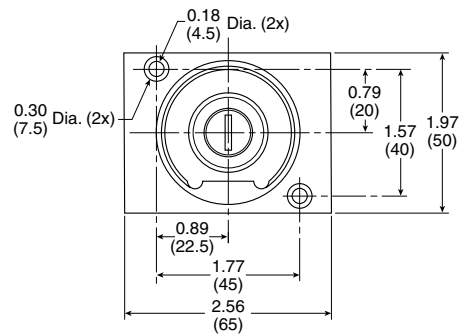
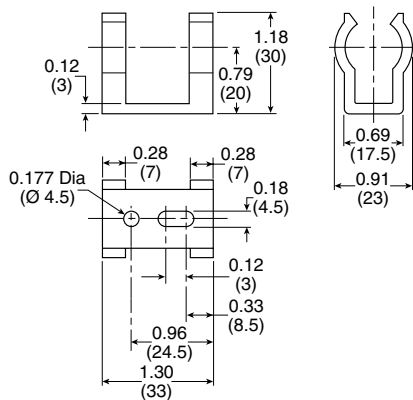

VF-2

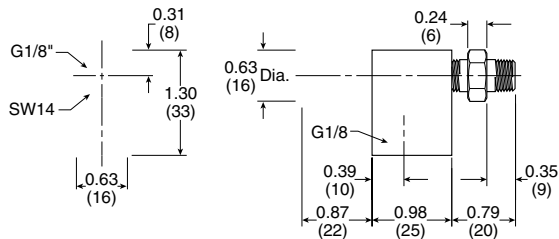

VF-6

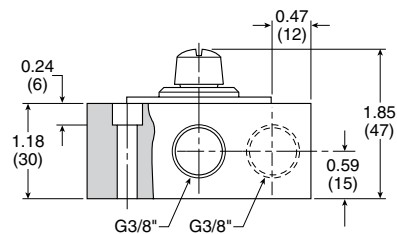

VF-3

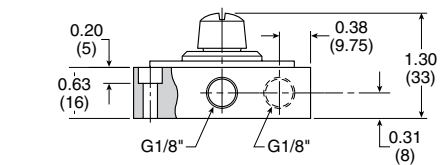
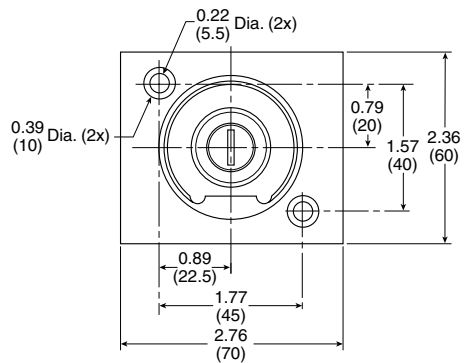
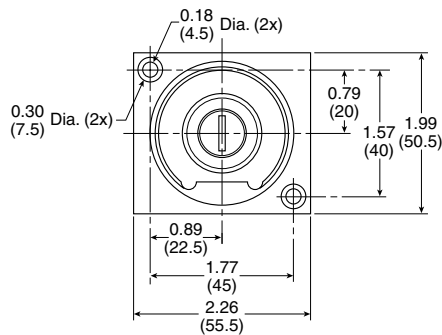

Parker plastic in-line filters provide easy monitoring, economy and safety. These shatterproof filters are airtight and can withstand high pressures.

A 10 micron porous plastic element prolongs element life under the most adverse environmental conditions.



Features

- To filter dust and other small particles from the vacuum flow
- Reduces the risk of operation breakdown or stoppage in the vacuum pump
- Replaceable filter element
- Made in the U.S.A.

B

Specifications

Media	Non-corrosive air
Operating vacuum range	-1 to 0 bar (-14.5 to 0 PSI)
Housing	Polypropylene (PP)
Material	Bowl Polyamide nylon (PA)
	Filter element Polyethylene (PE)
Temperature range	-20°C to 80°C
Removal efficiency	10 µm
Maximum pressure	10 bar (150 PSI)

Ordering information

Port size	Flow l/mn*	Weight (g)	Internal Volume cm ³	Filter area cm ²	Basic filter with element		Basic filter with 2 spare elements	
					NPT	BSPP	NPT	BSPP
1/8	710	48	34	80	VFP0CFC01	VFP0CFC11	VFP0CFC03	VFP0CFC13
1/4	990	56	40	80	VFP1CFC01	VFP1CFC11	VFP1CFC03	VFP1CFC13
3/8	1275	70	44	80	VFP2CFC01	VFP2CFC11	VFP2CFC03	VFP2CFC13
1/2	3680	187	195	260	VFP3CFC01	VFP3CFC11	VFP3CFC03	VFP3CFC13
3/4	4955	182	211	260	VFP4CFC01	VFP4CFC11	VFP4CFC03	VFP4CFC13
1	8210	425	495	480	VFP5CFC01	VFP5CFC11	VFP5CFC03	VFP5CFC13
1-1/2	12176	533	675	570	VFP6CFC01	VFP6CFC11	VFP6CFC03	VFP6CFC13

* 6.2 bar (90 PSI) inlet and 0.3 bar (5 PSI) pressure drop

Dimensions (mm)

Part number	A	B	C	D	E
VFP0CFC*1	78.7	61	48.3	50.8	10.2
VFP1CFC*1	78.7	61	48.3	50.8	10.2
VFP2CFC*1	78.7	61	48.3	50.8	10.2
VFP3CFC*1	91.4	129.5	73.6	111.6	17.8
VFP4CFC*1	91.4	129.5	73.6	116.9	12.7
VFP5CFC*1	124.5	162.6	101.6	142.2	20.3
VFP6CFC*1	132.1	209.9	101.6	175.3	30.5

* 0 (NPT), 1 (BSPP)

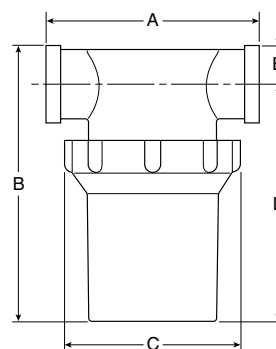

Replacement components

Part number	Size	Part number
Clear Bowl Kit (Includes O-ring)	1/8, 1/4, 3/8	PS577601
	1/2, 3/4	PS577602
	1, 1-1/2	PS577603
BUNA O-ring	1/8, 1/4, 3/8	PS577701
	1/2, 3/4	PS577702
	1, 1-1/2	PS577703
Filter Element Kit*	1/8	PS577801
	1/4	PS577801
	3/8	PS577801
	1/2	PS577802
Filter Element Kit*	3/4	PS577802
	1	PS577803
	1-1/2	PS577804

* All Filter Elements are sold as a 3-pack.

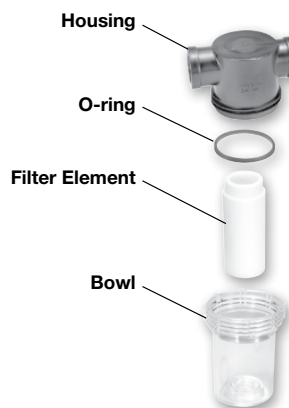

Protect the environment against harmful noise levels with quality silencers.



B

Ordering information

For generator series	Male connection	Part number
CV-05, CV-10	G1/8"	MSS-01
CV-05, CV-10	G1/8"	MSS-02
CV-15, MCA-10/13	G1/4"	MSM-01
CV-20	G1/2"	MSL-02
CV-25, CV-30	G3/4"	MS6-01

Specifications

Media	Non-corrosive air
Maximum pressure	8.8 bar (128 PSI)
Operating temperature	5°C to 55°C
Silencing effect	20 dB

Materials

Material housing	Material element	Media	Weight (g)	Part number
Polyacetal	Felt, Urethane	Air	4.9	MSS-01
Polyacetal	Stainless steel	Oil	4.9	MSS-02
Polyurethane	Felt	Air	6.8	MSM-01
Nylon	Vinyl	Air	25	MSL-02
Nylon	Polyvinyl Forma	Air	57	MS6-01

Dimensions

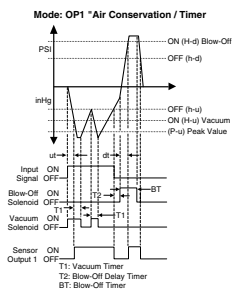

MSS-01

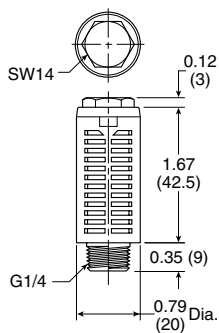

MSM-01

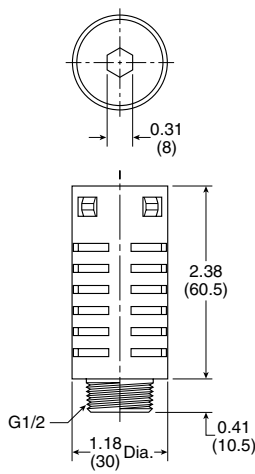

MSL-02

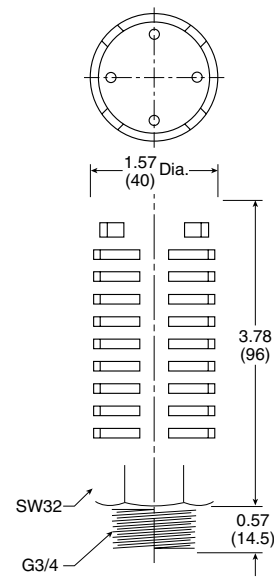

MS6-01

The plastic silencer is designed to give excellent noise reduction with a minimum effect on air efficiency. The “Trimline” design allows for locating the silencer in the tightest places without extra plumbing or fittings. Fits directly into the exhaust port of most commercial valves. Open surface area of element allows for rapid discharge of air without undesirable back pressure.

Features

- Compact
- Lightweight
- Easy to install
- Excellent noise reduction
- Protects components from contamination
- NPT & BSPT threads available



Specifications

Pressure rating	0 to 10 bar (0 to 145 PSI)
Temperature rating	-10°C to 60°C

Materials

Body	Acetal (Plastic)
Element	Polyethylene

**Ordering information,
 Dimensions**

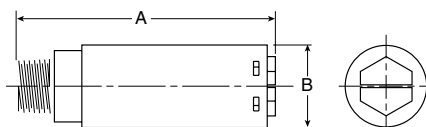

Thread size	A	B	Maximum flow (l/mn) 100 PSIG inlet	Sound pressure level (dBA)		Part number	
				20 PSIG inlet	100 PSIG inlet	BSPT	NPT
M5	11	8	425	69	79		AS-5
1/8”	40	16	1444	69	81	AS-6	ASN-6
1/4”	65	21	3500	67	84	AS-8	ASN-8
3/8”	85	25	7000	83	98	AS-10	ASN-10
1/2”	95	30	10480	69	96	AS-15	ASN-15



A

Air consumption

The amount of air in (measured in SCFM) consumed to achieve the maximum rated vacuum level of the venturi.

Air-economizing function

Integrated vacuum generators have the capacity to minimize air consumption by utilizing the built in check valve. Once a predetermined vacuum level has been achieved (with a non-porous application), the check valve can maintain the vacuum level within the system. The hysteresis feature of the vacuum sensor can maintain the vacuum level of the system indefinitely when properly wired to the vacuum solenoid pilot valve.

B

B

Blow-off needle

This is a flow adjustment supplied on integrated units to control the flow rate of the blow-off release.

Blow-off time

The amount of time required to break the vacuum and release the product in a pick and place application. This is signal controlled by the PLC or by the MVS-201 sensor.

Blow-off release master valve

This is a shuttle valve that works by differential forces which is piloted by a 2-3 valve. This valve is always configured normally closed.

E

Emergency stop

Emergency stop conditions for factory automation; this is an external override condition that is usually activated by the machine operator to temporarily shut the equipment down. The relevance to vacuum is the ability of the vacuum equipment to maintain the last output state of the control circuit. This feature would prevent part loss during this event as a normally closed system could maintain the current vacuum state without the presence of power.

F

Filtration

Filtration between the pad and generator is recommended. Regular maintenance of filters maintains the efficiency of the system.

I

Integrated vacuum generator

A vacuum venturi with integrated vacuum and blow-off release pilot valves built on the unit to minimize response times of the system. The unit may also incorporate filters, silencers, blow-off flow controls, and optional sensors.

L

Last output state

During an emergency stop or power loss event, emergency stop circuits from Parker can maintain the current state of operation. This is referred to as maintaining the last output state from the system controls.

P

Part present signal

Each sensor has an available NPN / PNP output and can be used for numerous purposes. One of them is a part present signal that usually signifies that a preset output for a vacuum level has been achieved and it is safe to proceed. The accuracy and repeatability of this signal can be critical to high speed applications. False or dropped signals can interrupt the systems operations. Therefore, stable vacuum levels and output settings near the "part-off" vacuum level are critical.

"Part-on" / "Part-off" vacuum differential

You must determine the highs and lows of the vacuum system in order to properly set the sensor outputs. Typically with venturi systems at fixed operating pressures, the maximum vacuum level is known. The "Part-off" vacuum level of the system must be determined by operating the system "open" while the sensor displays the level of vacuum in the system. This is known as the "Part-on" / "Part-off" differential in vacuum levels. Once this window of vacuum is known, the part present signal could be set in the middle between these vacuum levels. Ideally, it would be best if this window was as big as possible to avoid any issues with the sensors. Yet, sometimes by design or necessity, this window is very small or insignificant due to a high speed operation. To maximize the speed of the machinery, reduce the response time of the sensor output by setting the output around 1 inHg above the open vacuum level. The system response time is minimized and thus the "Part-on" / "Part-off" window is insignificant.

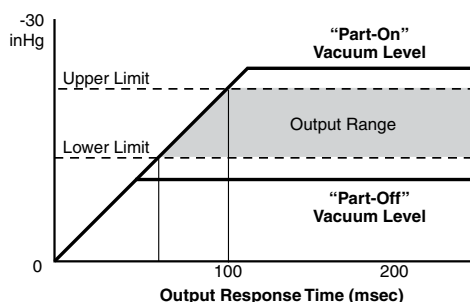

Power loss

This refers to loss of electrical power supply to the system. Unlike other pneumatic components with safety features, loss of electrical power to a normally closed vacuum circuit could be catastrophic; possibly resulting in dropping the product. To prevent this situation, consider an E-stop circuit or a normally open vacuum circuit.

Pressure sensor

A piezo resistive sensor used to monitor pressure levels in the system. The sensors supply NPN/PNP open collector transistor outputs back to the PLC for confirmation.

__R__

Response time

The time to evacuate the air out of a closed system to a certain vacuum level. This is critical to the overall performance of the vacuum system.

__T__

Threads

NPT (National Pipe Taper)
BSPT (British Standard Pipe Taper)
BSPP (British Standard Pipe Parallel)
G (Gaus)
M (Metric)
NPS (Dry Seal American Standard Fuel Internal Straight Pipe)

__V__

Vacuum

Any reference to vacuum or negative pressures could be defined as a force applied to a closed system by the difference in the number of air molecules within a chamber, enclosure, piping system, etc. to the number of air molecules outside of these systems or enclosures. The outside atmospheric pressure is larger and applies a force to the lesser pressures in the systems or enclosures. Therefore, vacuum is a differential pressure whereby atmosphere is the reference and external force.

Vacuum confirmation

Term used to describe an output signal NPN/PNP from the sensor to the PLC when the suction cup has made a proper seal with the product before transfer. This verifies that the vacuum level is safe to proceed.

Vacuum flow

Represented as l/mn, this is the rate at which air molecules can be evacuated through a venturi system.

Vacuum generator

This is sometimes referred to as an ejector. The venturi generates vacuum with compressed air by evacuating air molecules from a closed system.

Vacuum release pilot valve

Also referred to as Discharge valve, this valve pilots the Blow-off release master valve to effectively release the product during pick and place applications. This function is essential to high speed applications.

Vacuum master valve

This is a shuttle valve that works by differential forces which is piloted by a 2-3 valve. This valve can be configured normally closed or open.

B

PDE2654TCUK
Vacuum Products

B



Pressure Sensors

Section C

www.parker.com/pneu/sensors

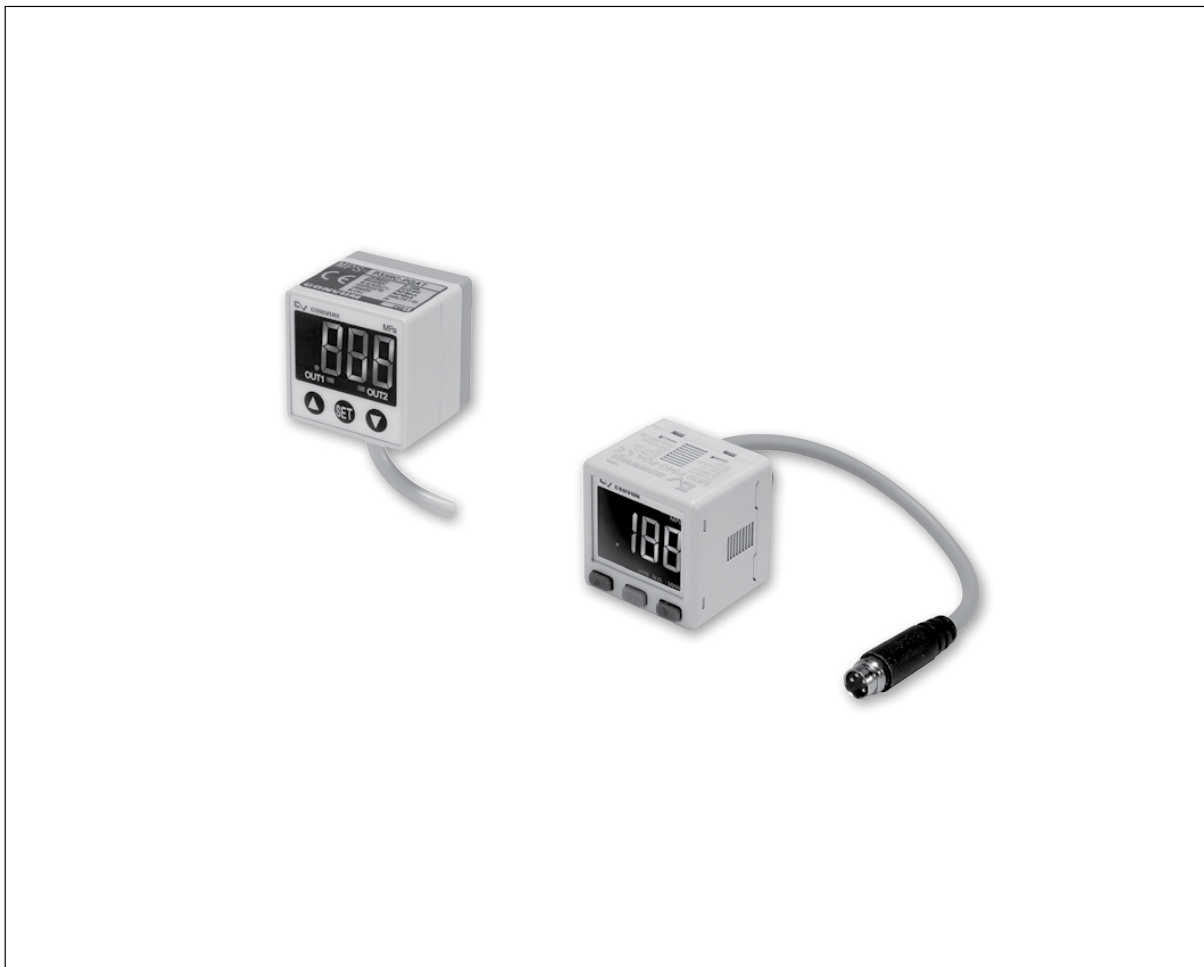

Cautions

Pressure sensors are designed to monitor pressure and are not a safety measure to prevent accidents.

The compatibility of the sensor is the responsibility of the designer of the system and specifications.

Operating environment

- Parker sensors have not been investigated for explosion-proof construction in hazardous environments.
- Do not use with flammable gases, liquids, or in hazardous environments.
- Avoid installing the sensor in locations where excessive voltage surges could damage or affect the performance of the sensor.

Operations



- Dedicate a power supply of 10.8 to 26.4VDC to the sensor and set the ripple to Vp-p10% or less. Avoid excessive voltage. Avoid voltage surges.
- A small amount of internal voltage drop is possible. Ensure the power supply minus any internal voltage drop exceeds the operating load.
- Verify the operating media is compatible with the specified sensor. Check the chemical make-up, operating temperatures, and maximum pressure ranges of the system before installing.
- Installation of air dryer system is recommended to remove moisture.

Installation

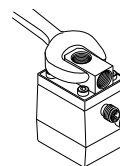
- Never insert an object into the pressure port other than an appropriate fluid connector.
- Avoid short-circuiting the sensor. Connect the brown lead to V+ and blue lead to 0V.
- Do not connect the output lead wires (black / white) to the power supply.
- Outputs not being used should be trimmed and insulated.
- Install as shown using the metal mounting bracket.



C

	Pressure range	Output type	Media	Maximum IP rating	Hysteresis output mode adjustment	Display	Page number
Technical data							C4
MPS-33							
	0 to -1 bar 0 to 10 bar -1 to 5 bar	(2) NPN / PNP with 1-5VDC Analog	Air, Non-corrosive gas	65	Variable, 100% F.S.	LED display (Red)	C5 - C9
MPS-34							
	0 to -1 bar 0 to 10 bar	(1) PNP / NPN with 4 to 20ma Analog	Air, Non-corrosive gas	40	Variable, 100% F.S.	LED display (Red / Green)	C10 - C15
Accessories	Cables						C23
Glossary						C24 - C26	



Programming options

Options	MPS 33	MPS 34
Outputs change N.O. / N.C.	✓	✓
Units of measure change	✓	✓
Hysteresis mode	✓	✓
Window comparator mode	✓	✓
Auto teach mode	✓	✓
Output response time	✓	✓
Lockout option	✓	✓
Password lockout	—	—
Max. value display	✓	✓
Min. value display	✓	✓
Zero reset	✓	✓
Red / Green LED display options	—	✓
Error output mode	✓	✓
Setting of decimal point	—	—

Selecting the proper pressure sensor

Selecting a Parker Pressure Sensor for an application is more than just selecting the correct operating range of the sensor. Electromechanical pressure sensors convert the applied pressure to an electrical signal. When pressure is applied, the diaphragm is deflected causing the diffused resistors to change resistance (piezoelectric effect), which yields an electrical signal proportional to the pressure change. Applications for pressure switches are numerous and important in today's high-tech manufacturing environment. Parker Pressure Sensors are solid state sensors and not mechanical switches. The outputs are either analog (1 -5vc, 4-20ma or 0-20ma) or PNP/NPN

Open Collector Transistor Type Outputs. The application will determine if the Open Collector Output is used in a Hysteresis or Window Comparator Function. The output mode of the sensor, as well as whether the sensor is normally open (non-passing) or normally closed (passing), can be programmed by you to fit your application. In addition to electrical outputs, most of these sensors have additional programming options that can be integrated into the system logic for additional benefits. These programming options are listed at the bottom of the page and are detailed on the next pages. Choose the best Pressure Sensor for the application based on Pressure Range, Output Type and additional programming options.

C

Programming options:

Outputs change N.O. / N.C.

The status of the Output at 0 bar is either Normally Open (Non-Passing) or Normally Closed (Passing) and can be set through programming.

Units of measure

The units of measure on the display can be changed to suit the application. Some choices are PSI, inHg, Bar, Kpa, Mpa or mmHg and are dependent on the pressure range of the sensor.

Hysteresis mode

This output mode provides one switch point and a reversing point. When the switch point pressure is achieved, the output (NPN / PNP) changes state and will not change back until the reversing point pressure is achieved.

Window comparator mode

This output mode provides two switch points. These two points create a window that the sensor output holds its state (NO or NC). This mode is also referred to as High/Low Setting. Anytime the pressure is higher or lower than the "window" the output changes state.

Auto setting mode

Programming feature that automatically sets switch point and reversing points for the outputs of the sensor based upon the minimum and maximum pressure readings of the sensor over time.

Output response time

Output response time is the time it takes for the output signal to change state after the pressure switch point is achieved. Sensor response time is typically less than 2.0 milliseconds and can be made slower by programming the response time in multiples of the standard sensor response time.

Lockout option

All sensor programming is locked out. Programming or LED Display cannot be changed when the sensor is locked out.

Password lockout

Lockouts the sensor from any programming changes. To unlock the sensor a user programmed 4 digit code must be entered into the sensor.

Max. valve display

Sensor will only display the maximum applied pressure reading until reset to measuring mode. A helpful tool in system set up.

Min valve display

Sensor will only display the minimum applied pressure reading until reset to measuring mode. A helpful tool in system set up.

Zero reset

Just like a pressure gauge, a pressure sensor measures the system pressure in relation to the atmospheric pressure. Pressure Sensors can be calibrated to the current atmospheric pressure by using the Zero Reset Function.

Red / Green LED display options

Display LED's change from Red to Green, or Green to Red when the output changes state. This can be a great visual indicator on a plant floor.

Error output

Error Message is displayed if the pressures, inputs, or outputs exceed the parameters of the sensor

Setting of decimal point

Depending on the units of measure, the decimal point can be adjusted up to three decimal points. (SCPSD only)

Features

- Sensor output:
 - 2 NPN or PNP open collector
 - Transistor output, 30VDC, 125mA with
 - Analog output, 1 to 5VDC
- Output response time less than 2.0 milliseconds
- RoHS
- Air and non-corrosive gase

Programming options

Outputs change N.O. / N.C.	✓
Units of measure change	✓
Hysteresis mode	✓
Window comparator mode	✓
Auto teach mode	✓
Output response time	✓
Lockout option	✓
Password lockout	—
Max. value display	✓
Min. value display	✓
Zero reset	✓
Red / Green LED display options	—
Error output mode	✓



MPS-33 Sensor only ordering numbers

Pressure range	Electrical output	Electrical connection	Part number	
			1/8 BSPP Female	1/8 NPSF Female
0 to -1 bar	(2) PNP with (1) 1-5VDC	2 m 5 Wire Lead Wire	MPS-V33G-PGAT	MPS-V33N-PGAT
0 to -1 bar	(2) NPN with (1) 1-5VDC	2 m 5 Wire Lead Wire	MPS-V33G-NGAT	MPS-V33N-NGAT
-1 to 5 bar	(2) PNP with (1) 1-5VDC	2 m 5 Wire Lead Wire	MPS-R33G-PGAT	MPS-R33N-PGAT
-1 to 5 bar	(2) NPN with (1) 1-5VDC	2 m 5 Wire Lead Wire	MPS-R33G-NGAT	MPS-R33N-NGAT
0 to 10 bar	(2) PNP with (1) 1-5VDC	2 m 5 Wire Lead Wire	MPS-P33G-PGAT	MPS-P33N-PGAT
0 to 10 bar	(2) NPN with (1) 1-5VDC	2 m 5 Wire Lead Wire	MPS-P33G-NGAT	MPS-P33N-NGAT

MPS-33 Accessories

Description	Part Number
Panel mounting bracket Note : Add "H" in suffix of Sensor Only Part Number to include with sensor	MPS-ACCH8
Surface mounting bracket Note : Add "K" in suffix of Sensor Only Part Number to include with sensor	MPS-ACCK8

Example: MPS-P33N-PGAT**K**, includes sensor MPS-P33N-PGA with bracket MPS-ACCK8

Internal circuit for open collector and analog output wiring

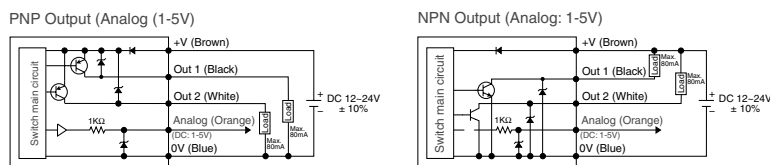

Lead Wiring



Specifications

	Vacuum (V)	Compound (R)	Positive (P)
Pressure range	-1 to 0 bar (-14.5 to 0 PSI)	-1 to 5 bar (-14.5 to 72 PSI)	0 to 10 bar (0 to 145 PSI)
Proof pressure	3 bar (44 PSI)	8 bar (116 PSI)	15 bar (218 PSI)
Display resolution, Units of measure	0.1, kPa	1, kPa	0.001, Mpa
	0.001, kgf/cm ²	0.01, kgf/cm ²	0.01, kgf/cm ²
	0.001, bar	0.01, bar	0.01, bar
	0.01, PSI	0.1, PSI	0.1, PSI
	0.1, inHg	—	—
Media	1, mmHg	—	—
	0.1, mmH ₂ O	—	—
	Air & non-corrosive gases, incombustible gases		
Pressure port	(G) 1/8" BSPP female, (N) 1/8" NPSF		
Operating temperature	0°C to 50°C		
Storage temperature	-20°C to 60°C		
Humidity	40 - 85% RH (no condensation)		
Electrical connection	(G) Grommet open lead, 5 wire (0.15mm ²)		
Power supply	12 to 24VDC ±10% or less, Ripple (Vp-p) 10% or less		
Display	3 + 1/2 digit, 1 color, 7-segment RED LED		
Display refresh	.1 to 3.0 Seconds, Variable (factory set at 0.1)		
Control output	NPN (Sinking), PNP (Sourcing), Open collector, max 80mA, 2 output		
Analog output	1 to 5VDC ≤ ±2.5% F.S. Linearity ≤1% of F.S.;		
Switch output	Output signal, NPN or PNP, Normally open or closed, LED indicator		
Output indicator	Green LED (OUT1), Red LED (OUT2)		
Output modes	Hysteresis or Window Comparator		
Response time	≤ 2.5ms (chattering-proof function: 24ms, 192ms, 786m selections)		
Repeatability	± 0.2% of F.S. ± 1 digit or less		
Thermal error	≤ ± 2% of F.S. or less at range of 0°C to 50°C		
General protection	IP65, CE marked, EMC-EN61000-6-2: 2001, with dust tube connection		
Current consumption	<55mA		
Vibration resistance	10 to 150Hz, Double amplitude 1.5mm, XYZ, 2 hrs.		
Shock resistance	980 m/s ² (about 10G), 3 times/each directions X, Y, Z		
Noise resistance	Vp-p400V, 10 ms, 0.5µs noise simulator		
Material	Housing: ABS (gray) , Pressure port: Zinc die-cast, Diaphragm: Silicone		
Mass	105g (including cable)		

Dimensions

1/8" Female

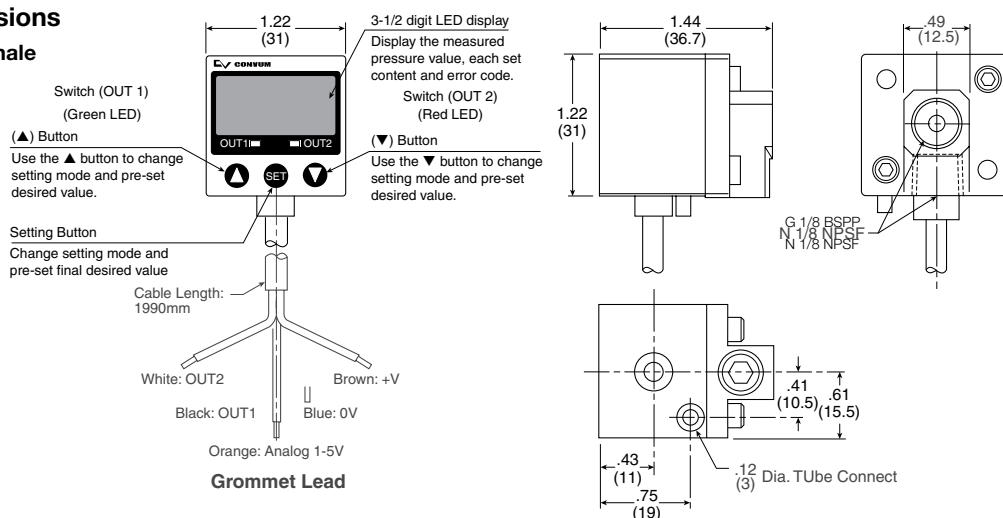

MPS-ACCH8
Panel mounting
bracket

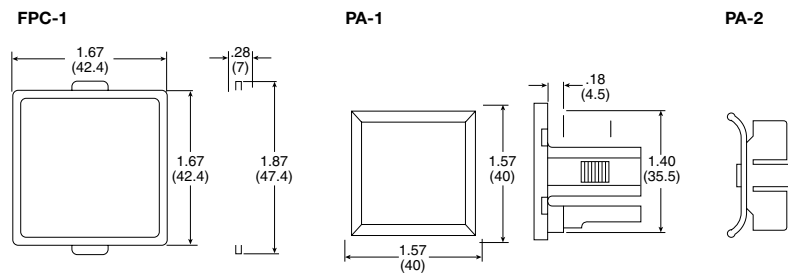
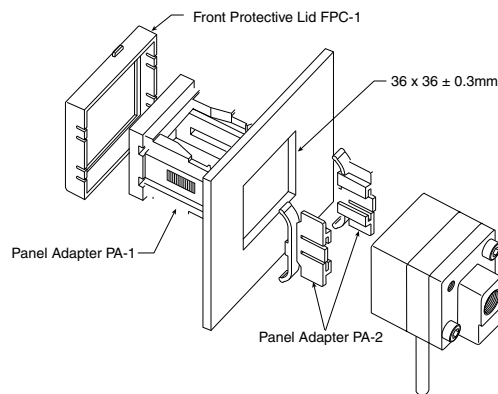

MPS-ACCK8
L3 & F3 mounting
brackets and
screws included

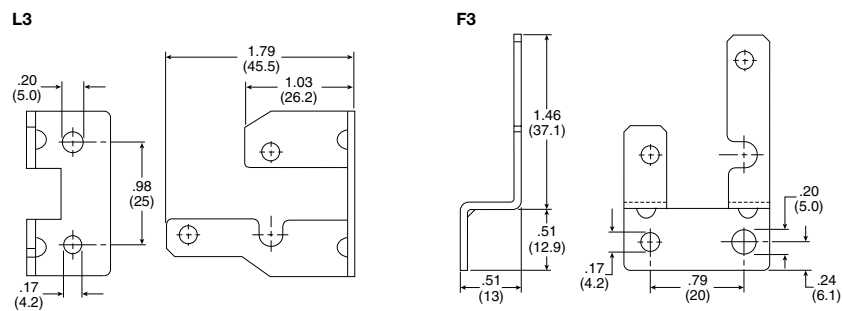
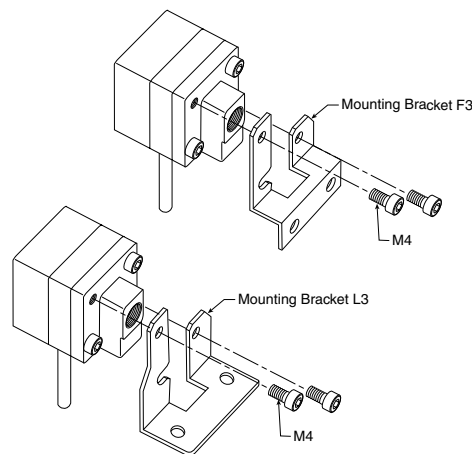

Initial setting mode

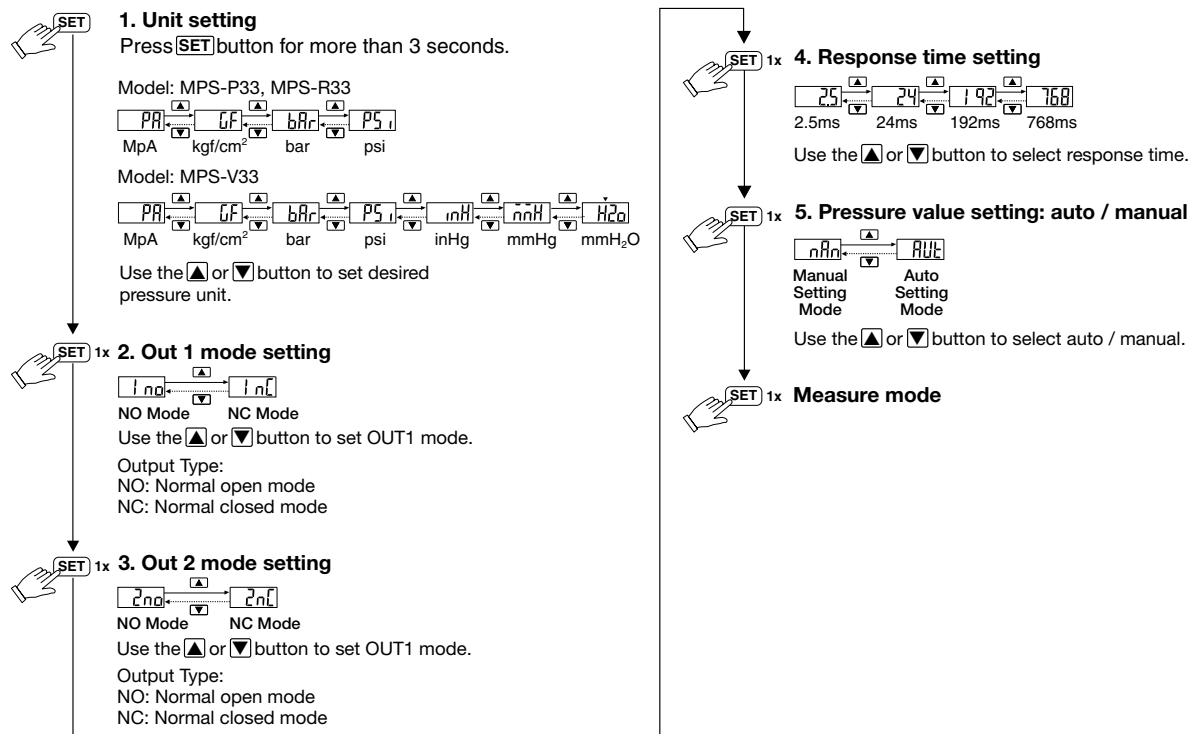

Zero point setting / the max. & min. display mode

Zero setting:

- press the ▼▲ button at the same time until the "00" is shown. Release the button to end zero setting.

The max. value display mode:

- Press ▲ button 2 seconds to enter the max. value mode, pressure sensor will detect the max. value and keep max. value displayed.
- Press ▲ button 2 seconds to return to measure mode display.

The min. value display mode:

- Press ▼ button 2 seconds to enter the min. value mode, pressure sensor will detect the min. value and keep min. value displayed.
- Press ▼ button 2 seconds to return to measure mode display.



Dustproof protector

Note: Required for IP65 rating protection and is included with sensor.

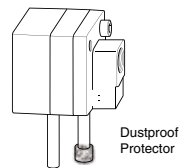

Key lock / unlock mode

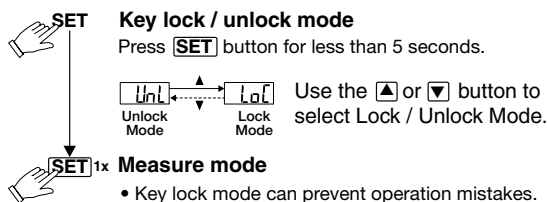

Output type

Hysteresis Mode

$P_1 (n_1) > P_2 (n_2)$
 $P_3 (n_3) > P_4 (n_4)$

Output Hysteresis value can be preset.

Normal open mode

Positive / Compound
(MPS-P33 / MPS-R33)

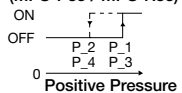

Vacuum (MPS-V33)

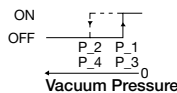

Normal close mode

Positive / Compound
(MPS-P33 / MPS-R33)

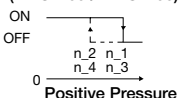

Vacuum (MPS-V33)

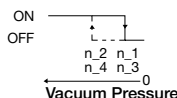

(Note)

When hysteresis mode setting is within 2 digits, if the input and pre-set pressure is quite near, pressure sensor output might cause chattering.

Window comparator Mode

$P_1 (n_1) < P_2 (n_2)$
 $P_3 (n_3) < P_4 (n_4)$

Within pressure setting range, pressure sensor output can be ON or OFF.

Normal open mode

Positive / Compound
(MPS-P33 / MPS-R33)

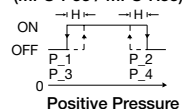

Vacuum (MPS-V33)

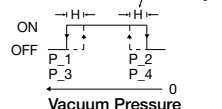

Normal close mode

Positive / Compound
(MPS-P33 / MPS-R33)

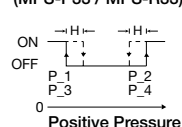

Vacuum (MPS-V33)

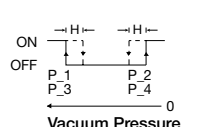

Manual setting mode

The LED shows: (P_*) at normal open mode and (n_*) at normal close mode. Pressure setting value is shown normally and will not lead to pressure sensor pause or stop working.

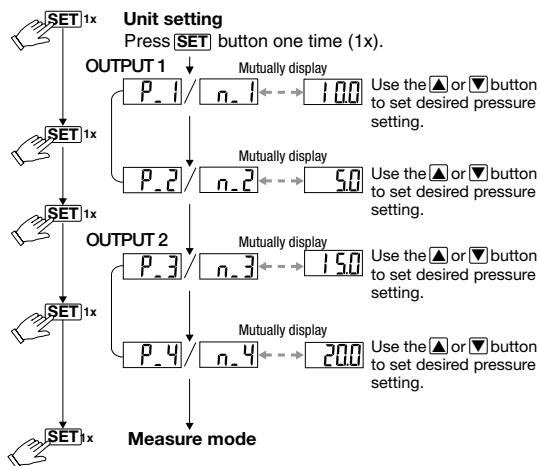

Auto setting mode

- *1. In case of without need of OUT1 pressure value setting, press $\nabla + \blacktriangle$ at the same time to enter (AP2) / (An2).
- *2. In case of without need of OUT2 pressure value setting, press $\nabla + \blacktriangle$ at the same time to enter measure mode.
- *3. The LED shows (AP*) at normal open mode and (An*) at normal closed mode.

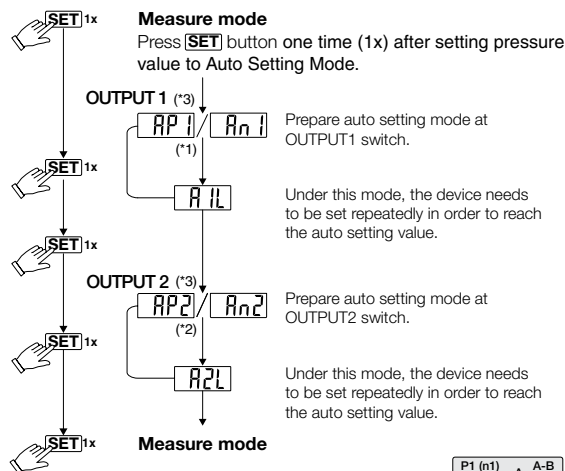

Calculation of setting value

A = The max. pressure value under auto setting mode.
B = The min. pressure value under auto setting mode.

$$P_1 (n_1) = A - \frac{A-B}{4}$$

$$P_3 (n_3) = B - \frac{A-B}{4}$$

$$P_2 (n_2) = B - \frac{A-B}{4}$$

$$P_4 (n_4) = A - \frac{A-B}{4}$$

Error messages

Error name	Display	Description	Solutions	
Excess load current error	OUT1	Er1	Excess load current of 80 mA	Turn off power and check the cause of overload current or lower the current load under 80 mA, then restart
	OUT2	Er2		
Residual pressure error	Er3	During zero reset, ambient pressure is over $\pm 3\%$ F.S.	Change input pressure to ambient pressure and perform zero reset again	
	---	The applied pressure is excess the upper limit of pressure setting	Adjust the pressure within applied pressure range	
	----	The applied pressure is excess the lower limit of pressure setting		
System error	Er4	Internal data error	Turn power off and then restart. If error condition remains, please return to factory for inspection	
	Er6	Internal system error		
	Er7	Internal data error		

Features

- Sensor output:
 - 1 NPN or PNP Open collector
 - Transistor output, 30VDC, 125mA with
 - Analog output, 4 to 20mA
- Output response time less than 2.0 milliseconds
- RoHS
- Air and non-corrosive gases
- Sensor face includes icons to show sensor programming status

Programming options

Outputs change N.O. / N.C.	✓
Units of measure change	✓
Hysteresis mode	✓
Window comparator mode	✓
Auto teach mode	✓
Output response time	✓
Lockout option	✓
Password lockout	—
Max. value display	✓
Min. value display	✓
Zero reset	✓
Red / Green LED display options	✓
Error output mode	✓

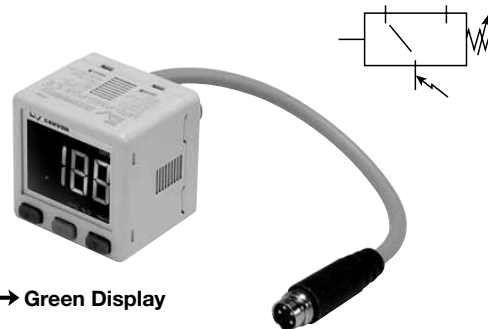

Red ←→ Green Display

Sensor pin out with analog output

Pin

- 1 Brown: 24VDC
- 2 White: 4 to 20mA
- 3 Blue: 0VDC
- 4 Black: PNP Open Collector Output 1

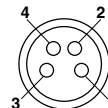

MPS-34 Sensor only ordering numbers

Pressure range	Electrical output	Electrical connection	Part number	
			1/8 BSPP male	1/8 NPSF male
0 to -1 bar	(1) PNP with (1) 4-20ma	M8, 4 Pin	MPS-V34G-PCI	MPS-V34N-PCI
0 to 10 bar	(1) PNP with (1) 4-20ma	M8, 4 Pin	MPS-P34G-PCI	MPS-P34N-PCI

MPS-34 Accessories

Description	Part number
Panel mounting bracket Note : Add "H" in suffix of Sensor Only Part Number to include with sensor	MPS-ACCH9
Surface mounting bracket Note : Add "K" in suffix of Sensor Only Part Number to include with sensor	MPS-ACCK10
Example: MPS-P34N-PCIK, includes sensor MPS-P34N-PCI with bracket MPS-ACCK10	
M8, 4-Pin, 2 meter cable	CB-M8-4P-2M-PUR
M8, 4-Pin, 5 meter cable	CB-M8-4P-5M-PUR

Internal circuit for open collector and analog output wiring

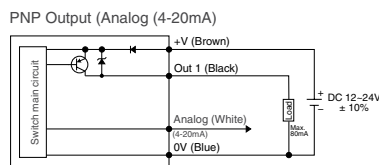

Specifications

	Vacuum (V)	Positive (P)
Pressure range	-1 to 0 bar (-14.5 to 0 PSI)	0 to 10 bar (0 to 145 PSI)
Proof pressure	3 bar (44PSI)	15 bar (218 PSI)
Display resolution , Units of measure	0.1, kPa	1, kPa
	0.001, kgf/cm ²	0.01, kgf/cm ²
	0.001, bar	0.01, bar
	0.01, PSI	0.1, PSI
	0.01, inHg	-
	1, mmHg	-
Media	Air & non-corrosive gases	
Pressure port	(G) 1/8 BSPP male, (N) 1/8" NPT male both with M5 female port	
Operating temperature	0°C to 50°C	
Storage temperature	-20°C to 60°C	
Humidity	35 to 85% RH (no condensation)	
Electrical connection	(C) 4-pin, M8 connector on 150mm lead wire	
Power supply	12 to 24VDC ±10%, Ripple (P-P) 10% or less	
Display	3 + 1/2 digit, 2 color, 7-segment RED / GREEN LED	
Display refresh	Timing update : 0.1 ~ 3 sec. (Factory Set Unit: 0.1 sec.)	
Switch output	Output signal, PNP, Normally open or closed, LED indicator, 125 mA max. output load	
Output modes	Hysteresis or Window Comparator	
Response time	≤ 2.5ms (chattering-proof function: 24ms, 250ms, 500ms, 1000ms and 1500ms selections)	
Repeatability	± 0.2% of F.S. ± 1 digit	
Output current	Output current 4 to 20mA; Linearity ±1.0% of F.S.; Maximum load impedance 300Ω at power supply of 12V; 600Ω at power supply of 12V; Minimum load impedance 50Ω	
Thermal error	0°C to 50°C 25°C (77°C) + 2% of F.S. or less at range of 0°C to 50°C	
General protection	IP40, CE marked, EMC-EN61000-6-2: 2001	
Current consumption	45mA (with no load)	
Vibration resistance	10 to 150Hz, Double amplitude 1.5mm, XYZ, 2 hrs.	
Shock resistance	980 m/s ² (about 10G), 3 times/each directions X, Y, Z	
Noise Resistance	Vp-p400V, 10 ms, 0.5μs noise simulator	
Material	Housing: ABS (gray) , Pressure port: Zinc die-cast, Diaphragm: Silicone	
Mass	45g with M8 connector	



Dimensions

1/8" Male

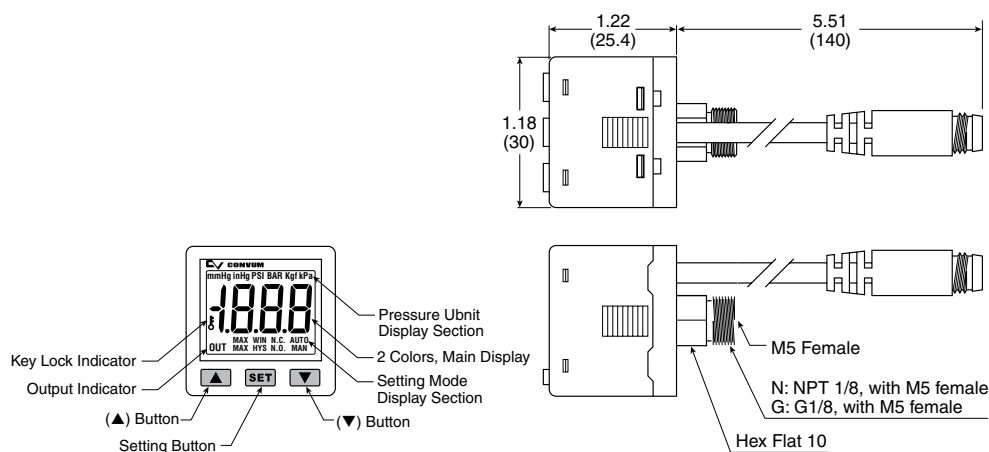

**MPS-ACCH9
Panel mounting
bracket**

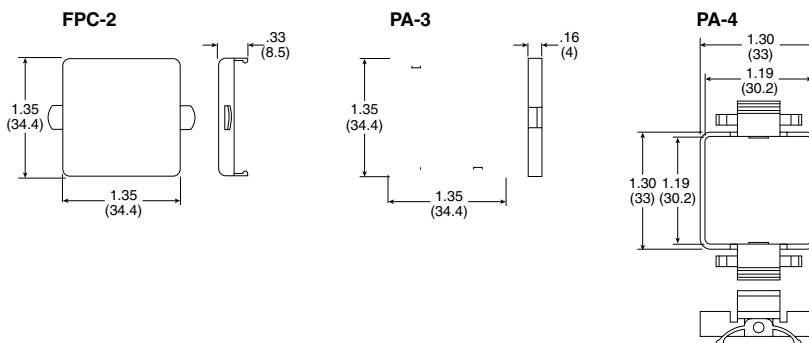
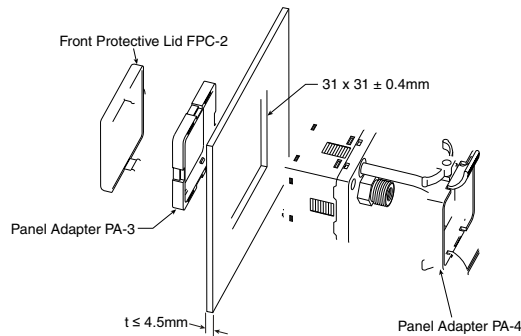

**MPS-ACCK10
L3 & F3 mounting
brackets and
screws included**

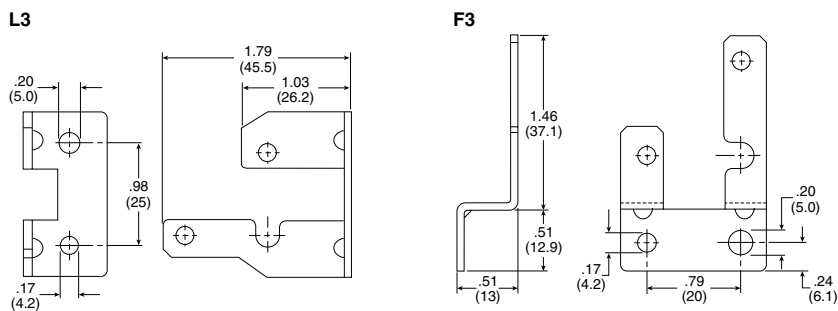
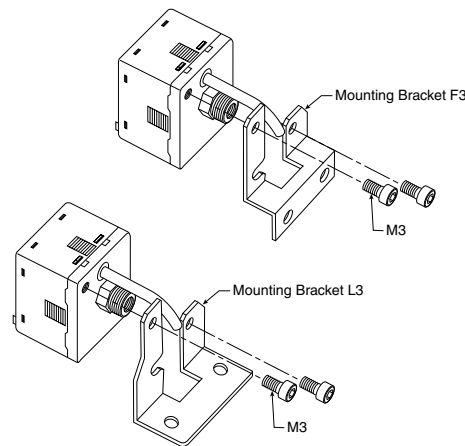

Initial setting mode

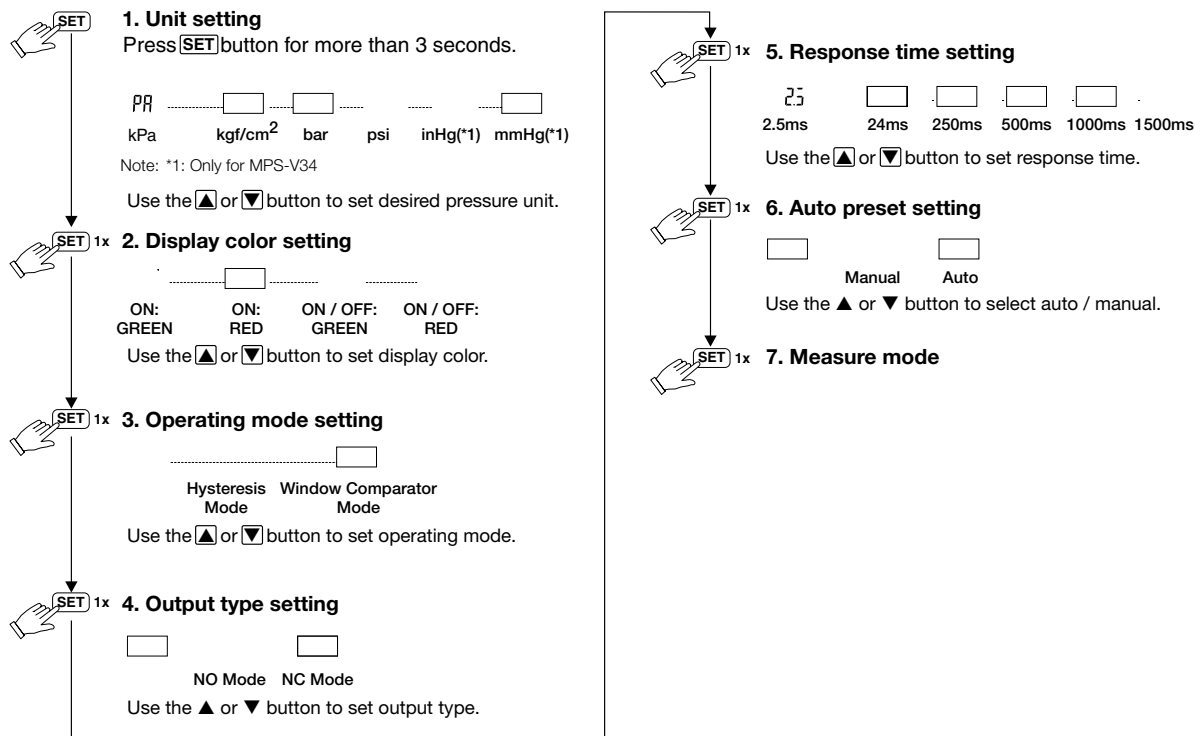

Zero point setting / the max. & min. display mode

Zero setting:

- press the **▼▲** button at the same time until the "00" is shown. Release the button to end zero setting.

The max. value display mode:

- Press **▲** button 2 seconds to enter the max. value mode, pressure sensor will detect the max. value and keep max. value displayed.
- Press **▲** button 2 seconds to return to measure mode display.

The min. value display mode:

- Press **▼** button 2 seconds to enter the min. value mode, pressure sensor will detect the min. value and keep min. value displayed.
- Press **▼** button 2 seconds to return to measure mode display.

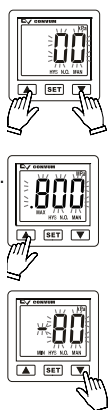

Key lock / unlock mode

Key lock / unlock mode

Press **SET** button for less than 5 seconds.

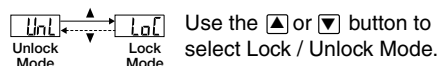

Measure mode

- Key lock mode can prevent operation mistakes.

Pressure setting mode

Hysteresis Mode

Output Hysteresis value can be preset.

Normal open mode

Positive (MPS-P34)

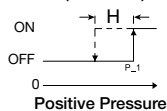

Vacuum (MPS-V34)

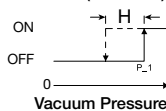

Normal close mode

Positive (MPS-P34)

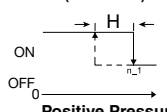

Vacuum (MPS-V34)

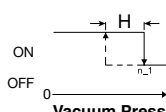

(Note)

In case hysteresis is set at less than or equal to 2 digits, switch output may chatter if input pressure fluctuates near the set point.

Window comparator Mode

Within pressure setting range, pressure sensor output can be ON or OFF.

Normal open mode

Positive (MPS-P34)

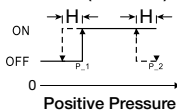

Vacuum (MPS-V34)

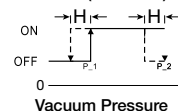

Normal close mode

Positive (MPS-P34)

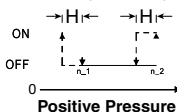

Vacuum (MPS-V34)

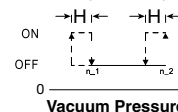

Manual setting mode

The LED shows: (P_n) at normal open mode and (n_n) at normal close mode. Pressure setting value is shown normally and will not lead to pressure sensor pause or stop working.

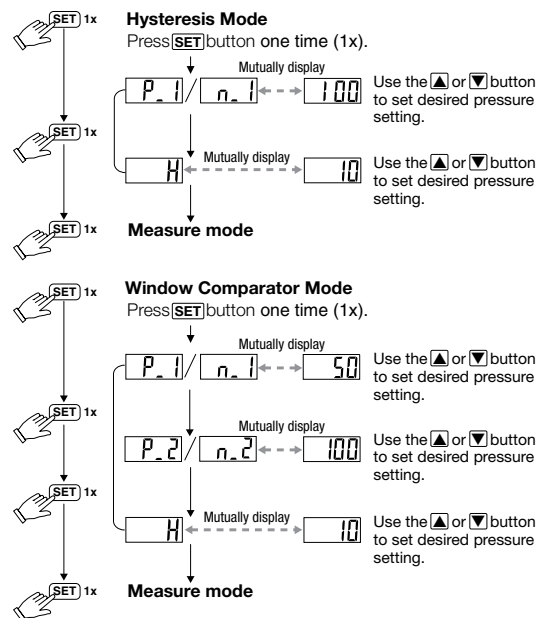

Auto setting mode

- The LED shows: (AP1) at normal open mode and (An1) at normal close mode.
- In case of without need of auto pressure value setting, press ▼+▲ at the same time to enter measure mode.

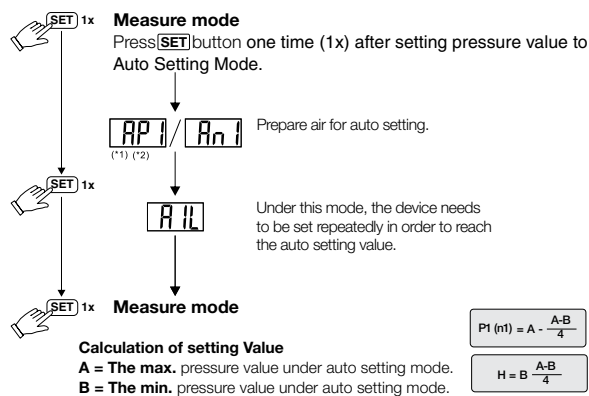

Fine adjustment mode

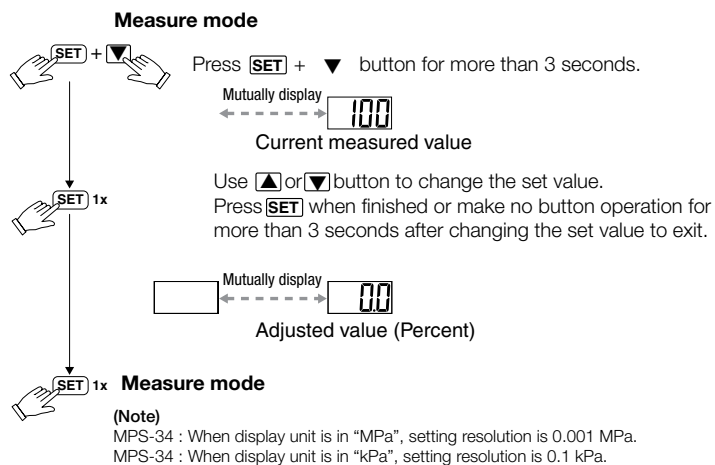

This function eliminates slight differences in the output values and allows uniformity in the numbers displayed. Displayed values of the pressure sensor can be calibrated to within $\pm 5\%$ for MPS-P34 and $\pm 2.5\%$ for series MPS-V34.

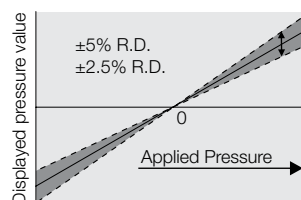

—:Factory setting display value set prior to shipment
■:Display calibration range



Error messages

Error name	Display	Description	Solutions
Excess load current error	<i>oCP</i>	Output load current of 125 mA	Turn off power and check the cause of overload current or lower the current load under 125 mA, then restart
Residual pressure error	<i>oUr</i>	During zero reset, ambient pressure is over $\pm 3\%$ F.S.	Change input pressure to ambient pressure and perform zero reset again
Applied pressure error	<i>HHH</i>	The applied pressure is excess the upper limit of pressure setting	Adjust the pressure within applied pressure range
	<i>LLL</i>	The applied pressure is excess the lower limit of pressure setting	
System Error	<i>Er4</i>	Internal data error	Turn power off and then restart. If error condition remains, please return to factory for inspection
	<i>Er6</i>	Internal system error	
	<i>Er7</i>	Internal data error	
	<i>Er8</i>	Internal system error	

Features

- M8, M12 female connector
- Length: 2m or 5m
- Cover: PVC or PUR
- Connection type: Swivel straight or angled
- IP67 swivel connector



Common Part Numbers

Connector	Contacts	Length	Cover	Part number
M8 female	4	2m	PUR	CB-M8-4P-2M-PUR
M8 female	4	5m	PUR	CB-M8-4P-5M-PUR
M8 angled female	4	5m	PUR	CB-M8-4P-5M-90-PUR
M12 female	4	2m	PVC	CB-M12-4P-2M
M12 female	5	2m	PVC	CB-M12-5P-2M

C

Dimensions

CB-M8-4P-2M, Female to Open Lead

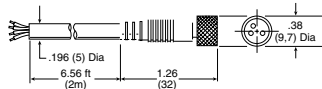

CB-M8-4P-5M, Female to Open Lead



CB-M8-4P-5M-90, Female to Open Lead

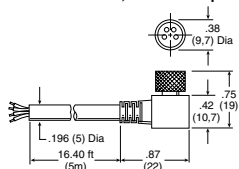

Female Interface
4-Pin, M8

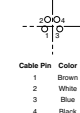

Male Interface
4-Pin, M8



CB-M12-4P-2M, Female to Open Lead
CB-M12-5P-2M, Female to Open Lead

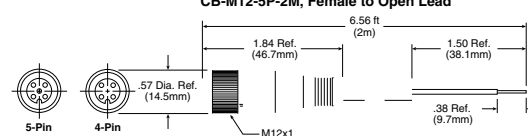

Female Interface
5-Pin, M12



Cable Pin	Color
1	Brown
2	White
3	Blue
4	Black
5	Gray

Female Interface
4-Pin, M12



Cable Pin	Color
1	Brown
2	White
3	Blue
4	Black

A

Accuracy

The PERCENTAGE difference between the true value and that indicated by an instrument is the measure of the instrument's accuracy. It is expressed as a percentage of the full-scale value of the reading according to the type of instrument.

Analog output

An analog output provides an output voltage that is proportional and linear to the pressure measured by the sensor. This output signal provides continuous feedback to the analog card of the PLC.

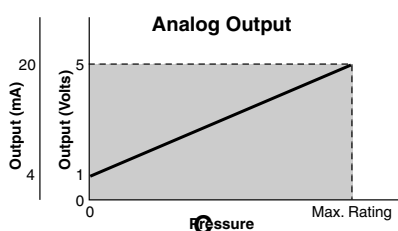

Cable connector type

4-Pin, M8 cable connector referred to as PICO or Micro connector. 4-Pin, 5-Pin, M12 cable connector referred to as Mini connector.

Class 2 power supply

Power source not exceeding 30VDC and 8 amps.

Connection port size

Pressure port connections on the back or bottom of the sensor.

Current consumption

Maximum current consumed during operation. Does not include the load current.

D

Display resolution

Resolution is 1/1024. The least possible measurable unit to display on the display. This will vary with the units of measure and is adjustable on some sensors.

Shown below are the different unit increments displayed for different pressures.

Compound	Low pressure	Vacuum	Pressure
bar: 0.01	bar: 0.001	bar: 0.001	bar: 0.01
kPa: 1	kPa: 0.1	kPa: 0.1	mPa: 0.001
kgf/cm ² : 0.01	kgf/cm ² : 0.001	mmHg: 1	kgf/cm ² : 0.01
PSI: 0.1	PSI: 0.1	inHg: 0.1	PSI: 1

Dielectric strength

Sensors ability to withstand excess voltages.

Digital display unit

Minimum unit displayed on the sensor.

E

Error message

Error message is displayed if the pressures, inputs, or outputs exceed the parameters of the sensor.

F

Full scale

Abbreviated as F.S. this is the operating pressure scale of the sensor.

G

Grommet type

Electrical lead from the sensor.

H

Hysteresis

The difference in pressure below the switch point pressure which controls the ON-OFF status of the output signal. (See Output modes)

I

Input impedance

The source of the electrical response of the sensing element expressed in ohms.

IP ratings

- IP40 - Protected against solid foreign objects of 0.04" (1mm) and greater.
Non-protected against the penetration of liquids.
- IP65 - Dust tight.
Protected against water jets.
- IP67 - Dust tight.
Protected against the effects of temporary immersion water.

Insulation resistance

Resistance between electrical circuit and the body, expressed in ohms at a voltage rating.

Internal voltage drop

Caused by the resistance of an electrical part in an electronic circuit. Example is a 2-wire pneumatic pressure switch.

L

LED

Electronic Display Technology

Load current

Amount of current flowing through the sensor once the output is activated.

Lock-out mode

Prevents accidental changes to the sensor settings.

M

Maximum operating pressure

Maximum operating pressure the sensor is rated for. Exceeding this pressure could damage the unit and will display FFF.

N

Noise resistance

Amount of electrical noise in the surrounding environment that could affect the sensor performance.

NPN pressure sensor output

NPN type open collector transistor outputs are solid state circuits that provide sinking output capabilities. When the transistor is on, the current for the load flows into the transistor. This output "sinks" toward 0VDC, 0mA.



O

ON / OFF output

The electrical state of the output signal.

Open collector transistor

Output circuit that sinks (NPN) or sources (PNP) at the pressure switch-point setting.

Operating humidity range

Humidity range for proper operation of equipment.

Operating indicator light

LED indicator is on when ON-OFF output is ON.

Operating pressure range

The pressure range the unit was designed to operate in.

Operating temperature range

Acceptable temperature range for the specifications listed in the catalog.

Operating voltage

Voltage range for normal operation.

Output modes

Switch point with hysteresis settings

This output mode provides one switch set point and a reversing point. The difference of these points is the hysteresis range (**h**). When the switch point pressure is achieved, the output (NPN / PNP) is activated if normally open or deactivated if normally closed. Typically, this mode is used for pressure confirmation. For positive pressure applications, this operating mode does not provide any output or alarms beyond the switch point in the case of excessive pressures.

In the Air Driven Cabinet Cooler application below, H=10 PSIG, h=2 PSIG. The unit will function properly above 10 PSIG and given some pressure variations, the sensor output will remain "on" until 8 PSIG. Below 8 PSIG the output will change to "off", which will be an indication that the cabinet is not being cooled efficiently or not at all.

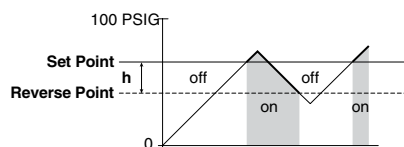
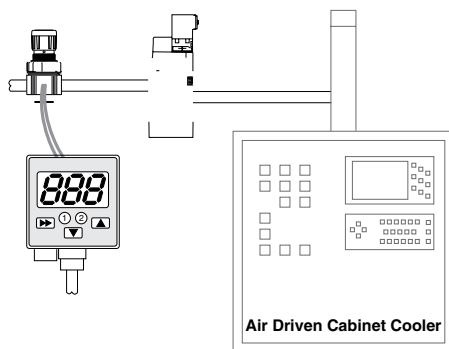

Window comparator setting

This output mode provides two switch points (A) and (b) that control the output signals (NPN / PNP) between the two pressures. This creates a "window" of operation and is sometimes referred to as "high / low" setting. The Window Comparator Mode provides an output or alarm when pressures exceed the upper or lower limit.

The sensor in the below application monitors the pressure to the valve controlling a pneumatic gripper. If the pressure is below (A), the gripper may not have enough holding capacity for the application and the part could drop. If the pressure is above b, the gripper may exert too much force on the part and damage the part. If the pressure is in the window of operation, in-between (A) and (b), the application is within design specification.

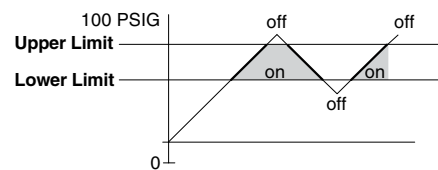
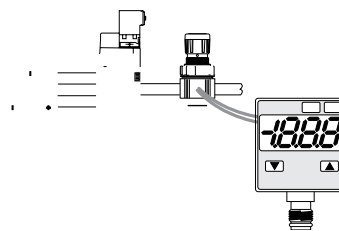

Output response time

Response time of the output signal after the pressure switch point is achieved. Measured in milliseconds.

P

Panel mounting brackets

Brackets used to panel mount the sensor.

PNP pressure sensor output

PNP type open collector transistor outputs are solid state circuits that provide sourcing output capabilities. When the transistor is on, the current for the load flows out of the transistor. This output "sources" toward 24VDC, 125mA.

R

Repeatability

The repeatability refers to the sensor's ability to provide the same output with consecutive applications of the same pressure input.

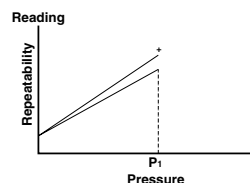

Repeatability is represented as a percentage of the full scale value of the sensor. All Parker sensors are rated $\pm 0.2\%$ F.S. P1 would be represented as $145 \text{ PSI} \times 0.002 = \pm 0.29 \text{ PSI}$.

Reverse voltage protection

Diode circuitry to prevent "cross-wire" damage during installation of the sensor.

__S__

Setpoints

The number of the ON-OFF output signals in one product. Product with 2 setting points means 2 output type.

Shock resistance

The amount of vibration the sensor can withstand without affecting performance.

Silicon diaphragm

This type of sensor is used for air and non-corrosive gas applications.

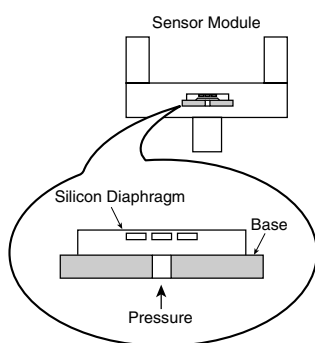

Stainless steel diaphragm

This type of sensor is used for liquids, non-corrosive to 316L or 630 stainless steel.

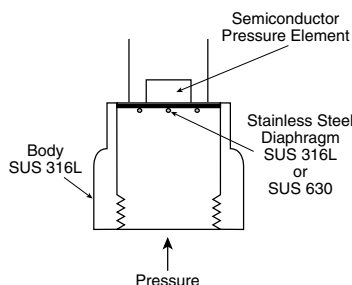

Switch output

This is a reference to a digital or NPN / PNP open collector transistor output from the sensor. The technology is binary logic.

__T__

Thermal error

Temperature characteristics vary with applications. The performance of the sensor can be affected by changes in ambient temperatures. The sensor rating is represented by a percentage of the F.S.

__W__

Wetted parts

Sensor body parts that are in contact with process-type fluids are referred to as wetted parts.

__Z__

Zero reset

The sensor technology is PSIA. Periodically, the sensor's atmospheric reference may need to be adjusted manually or automatically as a result of small changes in the atmospheric reference point.



PDE2654TCUK
Vacuum Products

C



C20

Parker Hannifin Corporation
Pneumatic Division - Europe

Safety Guide For Selecting And Using Pneumatic Division Products And Related Accessories

! WARNING:

FAILURE OR IMPROPER SELECTION OR IMPROPER USE OF PNEUMATIC DIVISION PRODUCTS, ASSEMBLIES OR RELATED ITEMS ("PRODUCTS") CAN CAUSE DEATH, PERSONAL INJURY, AND PROPERTY DAMAGE. POSSIBLE CONSEQUENCES OF FAILURE OR IMPROPER SELECTION OR IMPROPER USE OF THESE PRODUCTS INCLUDE BUT ARE NOT LIMITED TO:

- Unintended or mistimed cycling or motion of machine members or failure to cycle
- Work pieces or component parts being thrown off at high speeds.
- Failure of a device to function properly for example, failure to clamp or unclamp an associated item or device.
- Explosion
- Suddenly moving or falling objects.
- Release of toxic or otherwise injurious liquids or gasses.

Before selecting or using any of these Products, it is important that you read and follow the instructions below.

1. GENERAL INSTRUCTIONS

- 1.1. Scope:** This safety guide is designed to cover general guidelines on the installation, use, and maintenance of Pneumatic Division Valves, FRLs (Filters, Pressure Regulators, and Lubricators), Vacuum products and related accessory components.
- 1.2. Fail-Safe:** Valves, FRLs, Vacuum products and their related components can and do fail without warning for many reasons. Design all systems and equipment in a fail-safe mode, so that failure of associated valves, FRLs or Vacuum products will not endanger persons or property. -
- 1.3. Relevant International Standards:** For a good guide to the application of a broad spectrum of pneumatic fluid power devices see: ISO 4414:1998, Pneumatic Fluid Power – General Rules Relating to Systems. See www.iso.org for ordering information. -
- 1.4. Distribution:** Provide a copy of this safety guide to each person that is responsible for selection, installation, or use of Valves, FRLs - or Vacuum products. Do not select, or use Parker valves, FRLs or vacuum products without thoroughly reading and understanding this safety guide as well as the specific Parker publications for the products considered or selected. -
- 1.5. User Responsibility:** Due to the wide variety of operating conditions and applications for valves, FRLs, and vacuum products Parker - and its distributors do not represent or warrant that any particular valve, FRL or vacuum product is suitable for any specific end use system. This safety guide does not analyze all technical parameters that must be considered in selecting a product. The user, through its own analysis and testing, is solely responsible for:
 - Making the final selection of the appropriate valve, FRL, Vacuum component, or accessory.
 - Assuring that all user's performance, endurance, maintenance, safety, and warning requirements are met and that the application presents no health or safety hazards. -
 - Complying with all existing warning labels and / or providing all appropriate health and safety warnings on the equipment on which the valves, FRLs or Vacuum products are used; and, -
 - Assuring compliance with all applicable government and industry standards.
- 1.6. Safety Devices:** Safety devices should not be removed, or defeated.
- 1.7. Warning Labels:** Warning labels should not be removed, painted over or otherwise obscured.
- 1.8. Additional Questions:** Call the appropriate Parker technical service department if you have any questions or require any additional information. See the Parker publication for the product being considered or used, or call 1-800-CPARKER, or go to www.parker.com, for telephone numbers of the appropriate technical service department. -

2. PRODUCT SELECTION INSTRUCTIONS

- 2.1. Flow Rate:** The flow rate requirements of a system are frequently the primary consideration when designing any pneumatic system. System components need to be able to provide adequate flow and pressure for the desired application. -
- 2.2. Pressure Rating:** Never exceed the rated pressure of a product. Consult product labeling, Pneumatic Division catalogs or the instruction sheets supplied for maximum pressure ratings. -
- 2.3. Temperature Rating:** Never exceed the temperature rating of a product. Excessive heat can shorten the life expectancy of a product and result in complete product failure. -
- 2.4. Environment:** Many environmental conditions can affect the integrity and suitability of a product for a given application. Pneumatic Division products are designed for use in general purpose industrial applications. If these products are to be used in unusual circumstances such as direct sunlight and/or corrosive or caustic environments, such use can shorten the useful life and lead to premature failure of a product.
- 2.5. Lubrication and Compressor Carryover:** Some modern synthetic oils can and will attack nitrile seals. If there is any possibility of synthetic oils or greases migrating into the pneumatic components check for compatibility with the seal materials used. Consult the factory or product literature for materials of construction. -
- 2.6. Polycarbonate Bowls and Sight Glasses:** To avoid potential polycarbonate bowl failures:
 - Do not locate polycarbonate bowls or sight glasses in areas where they could be subject to direct sunlight, impact blow, or temperatures outside of the rated range. -
 - Do not expose or clean polycarbonate bowls with detergents, chlorinated hydro-carbons, ketones, esters or certain alcohols.
 - Do not use polycarbonate bowls or sight glasses in air systems where compressors are lubricated with fire resistant fluids such as phosphate ester and di-ester lubricants. -



2.7. Chemical Compatibility: For more information on plastic component chemical compatibility see Pneumatic Division technical bulletins Tec-3, Tec-4, and Tec-5

- 2.8. Product Rupture:** Product rupture can cause death, serious personal injury, and property damage.
- Do not connect pressure regulators or other Pneumatic Division products to bottled gas cylinders.
 - Do not exceed the maximum primary pressure rating of any pressure regulator or any system component.
 - Consult product labeling or product literature for pressure rating limitations.

3. PRODUCT ASSEMBLY AND INSTALLATION INSTRUCTIONS

3.1. Component Inspection: Prior to assembly or installation a careful examination of the valves, FRLs or vacuum products must be performed. All components must be checked for correct style, size, and catalog number. DO NOT use any component that displays any signs of nonconformance.

3.2. Installation Instructions: Parker published Installation Instructions must be followed for installation of Parker valves, FRLs and - vacuum components. These instructions are provided with every Parker valve or FRL sold, or by calling 1-800-CPARKER, or at - www.parker.com.

3.3. Air Supply: The air supply or control medium supplied to Valves, FRLs and Vacuum components must be moisture-free if ambient temperature can drop below freezing -

4. VALVE AND FRL MAINTENANCE AND REPLACEMENT INSTRUCTIONS

4.1. Maintenance: Even with proper selection and installation, valve, FRL and vacuum products service life may be significantly reduced without a continuing maintenance program. The severity of the application, risk potential from a component failure, and experience with any known failures in the application or in similar applications should determine the frequency of inspections and the servicing or replacement of Pneumatic Division products so that products are replaced before any failure occurs. A maintenance program must be established and followed by the user and, at minimum, must include instructions 4.2 through 4.10.

4.2. Installation and Service Instructions: Before attempting to service or replace any worn or damaged parts consult the appropriate Service Bulletin for the valve or FRL in question for the appropriate practices to service the unit in question. These Service and Installation Instructions are provided with every Parker valve and FRL sold, or are available by calling 1-800-CPARKER, or by accessing the Parker web site at www.parker.com.

4.3. Lockout / Tagout Procedures: Be sure to follow all required lockout and tagout procedures when servicing equipment. For more information see: OSHA Standard – 29 CFR, Part 1910.147, Appendix A, The Control of Hazardous Energy – (Lockout / Tagout) -

4.4. Visual Inspection: Any of the following conditions requires immediate system shut down and replacement of worn or damaged components: -

- Air leakage: Look and listen to see if there are any signs of visual damage to any of the components in the system. Leakage is an indication of worn or damaged components.
- Damaged or degraded components: Look to see if there are any visible signs of wear or component degradation.
- Kinked, crushed, or damaged hoses. Kinked hoses can result in restricted air flow and lead to unpredictable system behavior.
- Any observed improper system or component function: Immediately shut down the system and correct malfunction.
- Excessive dirt build-up: Dirt and clutter can mask potentially hazardous situations.

Caution: Leak detection solutions should be rinsed off after use.

4.5. Routine Maintenance Issues:

- Remove excessive dirt, grime and clutter from work areas.
- Make sure all required guards and shields are in place.

4.6. Functional Test: Before initiating automatic operation, operate the system manually to make sure all required functions operate properly and safely. -

4.7. Service or Replacement Intervals: It is the user's responsibility to establish appropriate service intervals. Valves, FRLs and vacuum products contain components that age, harden, wear, and otherwise deteriorate over time. Environmental conditions can significantly accelerate this process. Valves, FRLs and vacuum components need to be serviced or replaced on routine intervals. Service intervals need to be established based on:

- Previous performance experiences.
- Government and / or industrial standards.
- When failures could result in unacceptable down time, equipment damage or personal injury risk.

4.8. Servicing or Replacing of any Worn or Damaged Parts: To avoid unpredictable system behavior that can cause death, personal injury and property damage:

- Follow all government, state and local safety and servicing practices prior to service including but not limited to all OSHA Lockout Tagout procedures (OSHA Standard – 29 CFR, Part 1910.147, Appendix A, The Control of Hazardous Energy – Lockout / Tagout).
- Disconnect electrical supply (when necessary) before installation, servicing, or conversion.
- Disconnect air supply and depressurize all air lines connected to system and Pneumatic Division products before installation, service, or conversion.
- Installation, servicing, and / or conversion of these products must be performed by knowledgeable personnel who understand how pneumatic products are to be applied.
- After installation, servicing, or conversions air and electrical supplies (when necessary) should be connected and the product tested for proper function and leakage. If audible leakage is present, or if the product does not operate properly, do not put product or system into use.
- Warnings and specifications on the product should not be covered or painted over. If masking is not possible, contact your local representative for replacement labels.

4.9. Putting Serviced System Back into Operation: Follow the guidelines above and all relevant Installation and Maintenance Instructions supplied with the valve FRL or vacuum component to insure proper function of the system.

D

The items described in this document and other documents and descriptions provided by Parker Hannifin Corporation, its subsidiaries and its authorized distributors ("Seller") are hereby offered for sale at prices to be established by Seller. This offer and its acceptance by any customer ("Buyer") shall be governed by all of the following Terms and Conditions. Buyer's order for any item described in its document, when communicated to Seller verbally, or in writing, shall constitute acceptance of this offer. All goods or work described will be referred to as "Products".

1. Terms and Conditions. Seller's willingness to offer Products, or accept an order for Products, to or from Buyer is expressly conditioned on Buyer's assent to these Terms and Conditions and to the terms and conditions found on-line at www.parker.com/saleterms/. Seller objects to any contrary or additional term or condition of Buyer's order or any other document issued by Buyer.

2. Price Adjustments: Payments. Prices stated on the reverse side or preceding pages of this document are valid for 30 days. After 30 days, Seller may change prices to reflect any increase in its costs resulting from state, federal or local legislation, price increases from its suppliers, or any change in the rate, charge, or classification of any carrier. The prices stated on the reverse or preceding pages of this document do not include any sales, use, or other taxes unless so stated specifically. Unless otherwise specified by Seller, all prices are F.O.B. Seller's facility, and payment is due 30 days from the date of invoice. After 30 days, Buyer shall pay interest on any unpaid invoices at the rate of 1.5% per month or the maximum allowable rate under applicable law.

3. Delivery Dates: Title and Risk: Shipment. All delivery dates are approximate and Seller shall not be responsible for any damages resulting from any delay. Regardless of the manner of shipment, title to any products and risk of loss or damage shall pass to Buyer upon tender to the carrier at Seller's facility (i.e., when it's on the truck, it's yours). Unless otherwise stated, Seller may exercise its judgment in choosing the carrier and means of delivery. No deferral of shipment at Buyers' request beyond the respective dates indicated will be made except on terms that will indemnify, defend and hold Seller harmless against all loss and additional expense. Buyer shall be responsible for any additional shipping charges incurred by Seller due to Buyer's changes in shipping, product specifications or in accordance with Section 13, herein.

4. Warranty. Seller warrants that the Products sold hereunder shall be free from defects in material or workmanship for a period of twelve months from the date of delivery to Buyer or 2,000 hours of normal use, whichever occurs first. This warranty is made only to Buyer and does not extend to anyone to whom Products are sold after purchased from Seller. The prices charged for Seller's products are based upon the exclusive limited warranty stated above, and upon the following disclaimer: **DISCLAIMER OF WARRANTY: THIS WARRANTY COMPRISES THE SOLE AND ENTIRE WARRANTY PERTAINING TO PRODUCTS PROVIDED HEREUNDER. SELLER DISCLAIMS ALL OTHER WARRANTIES, EXPRESS AND IMPLIED, INCLUDING MERCHANTABILITY AND FITNESS FOR A PARTICULAR PURPOSE.**

5. Claims: Commencement of Actions. Buyer shall promptly inspect all Products upon delivery. No claims for shortages will be allowed unless reported to the Seller within 10 days of delivery. No other claims against Seller will be allowed unless asserted in writing within 60 days after delivery or, in the case of an alleged breach of warranty, within 30 days after the date within the warranty period on which the defect is or should have been discovered by Buyer. Any action based upon breach of this agreement or upon any other claim arising out of this sale (other than an action by Seller for any amount due to Seller from Buyer) must be commenced within thirteen months from the date of tender of delivery by Seller or, for a cause of action based upon an alleged breach of warranty, within thirteen months from the date within the warranty period on which the defect is or should have been discovered by Buyer.

6. LIMITATION OF LIABILITY. UPON NOTIFICATION, SELLER WILL, AT ITS OPTION, REPAIR OR REPLACE A DEFECTIVE PRODUCT, OR REFUND THE PURCHASE PRICE. IN NO EVENT SHALL SELLER BE LIABLE TO BUYER FOR ANY SPECIAL, INDIRECT, INCIDENTAL OR CONSEQUENTIAL DAMAGES ARISING OUT OF, OR AS THE RESULT OF, THE SALE, DELIVERY, NON-DELIVERY, SERVICING, USE OR LOSS OF USE OF THE PRODUCTS OR ANY PART THEREOF, OR FOR ANY CHARGES OR EXPENSES OF ANY NATURE INCURRED WITHOUT SELLER'S WRITTEN CONSENT, EVEN IF SELLER HAS BEEN NEGLIGENT, WHETHER IN CONTRACT, TORT OR OTHER LEGAL THEORY. IN NO EVENT SHALL SELLER'S LIABILITY UNDER ANY CLAIM MADE BY BUYER EXCEED THE PURCHASE PRICE OF THE PRODUCTS.

7. Contingencies. Seller shall not be liable for any default or delay in performance if caused by circumstances beyond the reasonable control of Seller.

8. User Responsibility. The user, through its own analysis and testing, is solely responsible for making the final selection of the system and Product and assuring that all performance, endurance, maintenance, safety and warning requirements of the application are met. The user must analyze all aspects of the application and follow applicable industry standards and Product information. If Seller provides Product or system options, the user is responsible for determining that such data and specifications are suitable and sufficient for all applications and reasonably foreseeable uses of the Products or systems.

9. Loss to Buyer's Property. Any designs, tools, patterns, materials, drawings, confidential information or equipment furnished by Buyer or any other items which become Buyer's property, may be considered obsolete and may be destroyed by Seller after two consecutive years have elapsed without Buyer placing an order for the items which are manufactured using such property. Seller shall not be responsible for any loss or damage to such property while it is in Seller's possession or control.

10. Special Tooling. A tooling charge may be imposed for any special tooling, including without limitation, dies, fixtures, molds and patterns, acquired to manufacture Products. Such special tooling shall be and remain Seller's property notwithstanding payment of any charges by Buyer. In no event will Buyer acquire any interest in apparatus belonging to Seller which is utilized in the manufacture of the Products, even if such apparatus has been specially converted or adapted for such manufacture and notwithstanding any charges paid by Buyer. Unless otherwise agreed, Seller shall have the right to alter, discard or otherwise dispose of any special tooling or other property in its sole discretion at any time.

11. Buyer's Obligation: Rights of Seller. To secure payment of all sums due or otherwise, Seller shall retain a security interest in the goods delivered and this agreement shall be deemed a Security Agreement under the Uniform Commercial Code. Buyer authorizes Seller as its attorney to execute and file on Buyer's behalf all documents Seller deems necessary to perfect its security interest. Seller shall have a security interest in, and lien upon, any property of Buyer in Seller's possession as security for the payment of any amounts owed to Seller by Buyer.

12. Improper use and Indemnity. Buyer shall indemnify, defend, and hold Seller harmless from any claim, liability, damages, lawsuits, and costs (including attorney fees), whether for personal injury, property damage, patent, trademark or copyright infringement or any other claim, brought by or incurred by Buyer, Buyer's employees, or any other person, arising out of: (a) improper selection, improper application or other misuse of Products purchased by Buyer from Seller; (b) any act or omission, negligent or otherwise, of Buyer; (c) Seller's use of patterns, plans, drawings, or specifications furnished by Buyer to manufacture Product; or (d) Buyer's failure to comply with these terms and conditions. Seller shall not indemnify Buyer under any circumstance except as otherwise provided.

13. Cancellations and Changes. Orders shall not be subject to cancellation or change by Buyer for any reason, except with Seller's written consent and upon terms that will indemnify, defend and hold Seller harmless against all direct, incidental and consequential loss or damage. Seller may change product features, specifications, designs and availability with notice to Buyer.

14. Limitation on Assignment. Buyer may not assign its rights or obligations under this agreement without the prior written consent of Seller.

15. Entire Agreement. This agreement contains the entire agreement between the Buyer and Seller and constitutes the final, complete and exclusive expression of the terms of the agreement. All prior or contemporaneous written or oral agreements or negotiations with respect to the subject matter are herein merged.

16. Waiver and Severability. Failure to enforce any provision of this agreement will not waive that provision nor will any such failure prejudice Seller's right to enforce that provision in the future. Invalidation of any provision of this agreement by legislation or other rule of law shall not invalidate any other provision herein. The remaining provisions of this agreement will remain in full force and effect.

17. Termination. This agreement may be terminated by Seller for any reason and at any time by giving Buyer thirty (30) days written notice of termination. In addition, Seller may by written notice immediately terminate this agreement for the following: (a) Buyer commits a breach of any provision of this agreement (b) the appointment of a trustee, receiver or custodian for all or any part of Buyer's property (b) the filing of a petition for relief in bankruptcy of the other Party on its own behalf, or by a third party (c) an assignment for the benefit of creditors, or (d) the dissolution or liquidation of the Buyer.

18. Governing Law. This agreement and the sale and delivery of all Products hereunder shall be deemed to have taken place in and shall be governed and construed in accordance with the laws of the State of Ohio, as applicable to contracts executed and wholly performed therein and without regard to conflicts of laws principles. Buyer irrevocably agrees and consents to the exclusive jurisdiction and venue of the courts of Cuyahoga County, Ohio with respect to any dispute, controversy or claim arising out of or relating to this agreement. Disputes between the parties shall not be settled by arbitration unless, after a dispute has arisen, both parties expressly agree in writing to arbitrate the dispute.

19. Indemnity for Infringement of Intellectual Property Rights. Seller shall have no liability for infringement of any patents, trademarks, copyrights, trade dress, trade secrets or similar rights except as provided in this Section. Seller will defend and indemnify Buyer against allegations of infringement of U.S. patents, U.S. trademarks, copyrights, trade dress and trade secrets ("Intellectual Property Rights"). Seller will defend at its expense and will pay the cost of any settlement or damages awarded in an action brought against Buyer based on an allegation that a Product sold pursuant to this Agreement infringes the Intellectual Property Rights of a third party. Seller's obligation to defend and indemnify Buyer is contingent on Buyer notifying Seller within ten (10) days after Buyer becomes aware of such allegations of infringement, and Seller having sole control over the defense of any allegations or actions including all negotiations for settlement or compromise. If a Product is subject to a claim that it infringes the Intellectual Property Rights of a third party, Seller may, at its sole expense and option, procure for Buyer the right to continue using the Product, replace or modify the Product so as to make it noninfringing, or offer to accept return of the Product and return the purchase price less a reasonable allowance for depreciation. Notwithstanding the foregoing, Seller shall have no liability for claims of infringement based on information provided by Buyer, or directed to Products delivered hereunder for which the designs are specified in whole or part by Buyer, or infringements resulting from the modification, combination or use in a system of any Product sold hereunder. The foregoing provisions of this Section shall constitute Seller's sole and exclusive liability and Buyer's sole and exclusive remedy for infringement of Intellectual Property Rights.

20. Taxes. Unless otherwise indicated, all prices and charges are exclusive of excise, sales, use, property, occupational or like taxes which may be imposed by any taxing authority upon the manufacture, sale or delivery of Products.

21. Equal Opportunity Clause. For the performance of government contracts and where dollar value of the Products exceed \$10,000, the equal employment opportunity clauses in Executive Order 11246, VEVRRA, and 41 C.F.R. §§ 60-1.4(a), 60-741.5(a), and 60-250.4, are hereby incorporated.



PDE2654TCUK
Vacuum Products

D



D4

Parker Hannifin Corporation
Pneumatic Division - Europe

PDE2654TCUK
Vacuum Products



Parker Hannifin Corporation
Pneumatic Division - Europe

Parker Worldwide

Europe, Middle East, Africa

AE – United Arab Emirates,

Dubai
Tel: +971 4 8127100
parker.me@parker.com

AT – Austria, Wiener Neustadt

Tel: +43 (0)2622 23501-0
parker.austria@parker.com

AT – Eastern Europe, Wiener Neustadt

Tel: +43 (0)2622 23501 900
parker.easteurope@parker.com

AZ – Azerbaijan, Baku

Tel: +994 50 2233 458
parker.azerbaijan@parker.com

BE/LU – Belgium, Nivelles

Tel: +32 (0)67 280 900
parker.belgium@parker.com

BY – Belarus, Minsk

Tel: +375 17 209 9399
parker.belarus@parker.com

CH – Switzerland, Etoy

Tel: +41 (0)21 821 87 00
parker.switzerland@parker.com

CZ – Czech Republic, Klecany

Tel: +420 284 083 111
parker.czechrepublic@parker.com

DE – Germany, Kaarst

Tel: +49 (0)2131 4016 0
parker.germany@parker.com

DK – Denmark, Ballerup

Tel: +45 43 56 04 00
parker.denmark@parker.com

ES – Spain, Madrid

Tel: +34 902 330 001
parker.spain@parker.com

FI – Finland, Vantaa

Tel: +358 (0)20 753 2500
parker.finland@parker.com

FR – France, Contamine s/Arve

Tel: +33 (0)4 50 25 80 25
parker.france@parker.com

GR – Greece, Athens

Tel: +30 210 933 6450
parker.greece@parker.com

HU – Hungary, Budapest

Tel: +36 1 220 4155
parker.hungary@parker.com

IE – Ireland, Dublin

Tel: +353 (0)1 466 6370
parker.ireland@parker.com

IT – Italy, Corsico (MI)

Tel: +39 02 45 19 21
parker.italy@parker.com

KZ – Kazakhstan, Almaty

Tel: +7 7272 505 800
parker.easteurope@parker.com

NL – The Netherlands, Oldenzaal

Tel: +31 (0)541 585 000
parker.nl@parker.com

NO – Norway, Asker

Tel: +47 66 75 34 00
parker.norway@parker.com

PL – Poland, Warsaw

Tel: +48 (0)22 573 24 00
parker.poland@parker.com

PT – Portugal, Leca da Palmeira

Tel: +351 22 999 7360
parker.portugal@parker.com

RO – Romania, Bucharest

Tel: +40 21 252 1382
parker.romania@parker.com

RU – Russia, Moscow

Tel: +7 495 645-2156
parker.russia@parker.com

SE – Sweden, Spånga

Tel: +46 (0)8 59 79 50 00
parker.sweden@parker.com

SK – Slovakia, Banská Bystrica

Tel: +421 484 162 252
parker.slovakia@parker.com

SL – Slovenia, Novo Mesto

Tel: +386 7 337 6650
parker.slovenia@parker.com

TR – Turkey, Istanbul

Tel: +90 216 4997081
parker.turkey@parker.com

UA – Ukraine, Kiev

Tel: +380 44 494 2731
parker.ukraine@parker.com

UK – United Kingdom, Warwick

Tel: +44 (0)1926 317 878
parker.uk@parker.com

ZA – South Africa, Kempton Park

Tel: +27 (0)11 961 0700
parker.southafrica@parker.com

North America

CA – Canada, Milton, Ontario

Tel: +1 905 693 3000

US – USA, Cleveland

Tel: +1 216 896 3000

Asia Pacific

AU – Australia, Castle Hill

Tel: +61 (0)2-9634 7777

CN – China, Shanghai

Tel: +86 21 2899 5000

HK – Hong Kong

Tel: +852 2428 8008

IN – India, Mumbai

Tel: +91 22 6513 7081-85

JP – Japan, Tokyo

Tel: +81 (0)3 6408 3901

KR – South Korea, Seoul

Tel: +82 2 559 0400

MY – Malaysia, Shah Alam

Tel: +60 3 7849 0800

NZ – New Zealand, Mt Wellington

Tel: +64 9 574 1744

SG – Singapore

Tel: +65 6887 6300

TH – Thailand, Bangkok

Tel: +662 186 7000 99

TW – Taiwan, Taipei

Tel: +886 2 2298 8987

South America

AR – Argentina, Buenos Aires

Tel: +54 3327 44 4129

BR – Brazil, Sao Jose dos Campos

Tel: +55 800 727 5374

CL – Chile, Santiago

Tel: +56 2 623 1216

MX – Mexico, Apodaca

Tel: +52 81 8156 6000

European Product Information Centre

Free phone: 00 800 27 27 5374

(from AT, BE, CH, CZ, DE, DK, EE, ES, FI, FR, IE, IL, IS, IT, LU, MT, NL, NO, PL, PT, RU, SE, SK, UK, ZA)

**Parker Hannifin Ltd**

Pneumatic Division Europe
The Collins Centre,
Lichfield South, Wall Island,
Birmingham Road, Lichfield.
WS14 0QP United Kingdom
Tel: +44 (0) 1543 483800
Fax: +44 (0) 1543 483801
www.parker.com

Your local authorized Parker distributor