

## Parker Worldwide

### Europe, Middle East, Africa

**AE – United Arab Emirates,** Dubai  
Tel: +971 4 8127100  
parker.me@parker.com

**AT – Austria,** St. Florian  
Tel: +43 (0)7224 66201  
parker.austria@parker.com

**AZ – Azerbaijan,** Baku  
Tel: +994 50 2233 458  
parker.azerbaijan@parker.com

**BE/NL/LU – Benelux,** Hendrik Ido Ambacht  
Tel: +31 (0)541 585 000  
parker.nl@parker.com

**BG – Bulgaria,** Sofia  
Tel: +359 2 980 1344  
parker.bulgaria@parker.com

**BY – Belarus,** Minsk  
Tel: +48 (0)22 573 24 00  
parker.poland@parker.com

**CH – Switzerland,** Etoy  
Tel: +41 (0)21 821 87 00  
parker.switzerland@parker.com

**CZ – Czech Republic,** Klecany  
Tel: +420 284 083 111  
parker.czechrepublic@parker.com

**DE – Germany,** Kaarst  
Tel: +49 (0)2131 4016 0  
parker.germany@parker.com

**DK – Denmark,** Ballerup  
Tel: +45 43 56 04 00  
parker.denmark@parker.com

**ES – Spain,** Madrid  
Tel: +34 902 330 001  
parker.spain@parker.com

**FI – Finland,** Vantaa  
Tel: +358 (0)20 753 2500  
parker.finland@parker.com

**FR – France,** Contamine s/Arve  
Tel: +33 (0)4 50 25 80 25  
parker.france@parker.com

**GR – Greece,** Piraeus  
Tel: +30 210 933 6450  
parker.greece@parker.com

**HU – Hungary,** Budaörs  
Tel: +36 23 885 470  
parker.hungary@parker.com

**IE – Ireland,** Dublin  
Tel: +353 (0)1 466 6370  
parker.ireland@parker.com

**IL – Israel,**  
Tel: +39 02 45 19 21  
parker.israel@parker.com

**IT – Italy,** Corsico (MI)  
Tel: +39 02 45 19 21  
parker.italy@parker.com

**KZ – Kazakhstan,** Almaty  
Tel: +7 7273 561 000  
parker.easteurope@parker.com

**NO – Norway,** Asker  
Tel: +47 66 75 34 00  
parker.norway@parker.com

**PL – Poland,** Warsaw  
Tel: +48 (0)22 573 24 00  
parker.poland@parker.com

**PT – Portugal,**  
Tel: +351 22 999 7360  
parker.portugal@parker.com

**RO – Romania,** Bucharest  
Tel: +40 21 252 1382  
parker.romania@parker.com

**RU – Russia,** Moscow  
Tel: +7 495 645-2156  
parker.russia@parker.com

**SE – Sweden,** Spånga  
Tel: +46 (0)8 59 79 50 00  
parker.sweden@parker.com

**SK – Slovakia,** Banská Bystrica  
Tel: +421 484 162 252  
parker.slovakia@parker.com

**SL – Slovenia,** Novo Mesto  
Tel: +386 7 337 6650  
parker.slovenia@parker.com

**TR – Turkey,** Istanbul  
Tel: +90 216 4997081  
parker.turkey@parker.com

**UA – Ukraine,** Kiev  
Tel: +48 (0)22 573 24 00  
parker.poland@parker.com

**UK – United Kingdom,** Warwick  
Tel: +44 (0)1926 317 878  
parker.uk@parker.com

**ZA – South Africa,** Kempton Park  
Tel: +27 (0)11 961 0700  
parker.southafrica@parker.com

### North America

**CA – Canada,** Milton, Ontario  
Tel: +1 905 693 3000

**US – USA,** Cleveland  
Tel: +1 216 896 3000

### Asia Pacific

**AU – Australia,** Castle Hill  
Tel: +61 (0)2-9634 7777

**CN – China,** Shanghai  
Tel: +86 21 2899 5000

**HK – Hong Kong**  
Tel: +852 2428 8008

**IN – India,** Mumbai  
Tel: +91 22 6513 7081-85

**JP – Japan,** Tokyo  
Tel: +81 (0)3 6408 3901

**KR – South Korea,** Seoul  
Tel: +82 2 559 0400

**MY – Malaysia,** Shah Alam  
Tel: +60 3 7849 0800

**NZ – New Zealand,** Mt Wellington  
Tel: +64 9 574 1744

**SG – Singapore**  
Tel: +65 6887 6300

**TH – Thailand,** Bangkok  
Tel: +662 186 7000

**TW – Taiwan,** Taipei  
Tel: +886 2 2298 8987

### South America

**AR – Argentina,** Buenos Aires  
Tel: +54 3327 44 4129

**BR – Brazil,** Sao Jose dos Campos  
Tel: +55 800 727 5374

**CL – Chile,** Santiago  
Tel: +56 2 623 1216

**MX – Mexico,** Toluca  
Tel: +52 72 2275 4200

Sensors and switches for Pressure, Temperature, Level and Flow

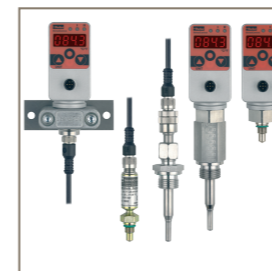

## Sensors and switches for Pressure, Temperature, Level and Flow





At Parker, we're guided by a relentless drive to help our customers become more productive and achieve higher levels of profitability by engineering the best systems for their requirements. It means looking at customer applications from many angles to find new ways to create value. Whatever the motion and control technology need, Parker has the experience, breadth of product and global reach to consistently deliver. No company knows more about motion and control technology than Parker. For further info call 00800 27 27 5374

## Parker's Motion & Control Technologies



**Aerospace**  
**Key Markets**  
Aftermarket services  
Commercial transports  
Engines  
General & business aviation  
Helicopters  
Launch vehicles  
Military aircraft  
Missiles  
Power generation  
Regional transports  
Unmanned aerial vehicles

**Key Products**  
Control systems & actuation products  
Engine systems & components  
Fluid conveyance systems & components  
Fluid metering, delivery & atomization devices  
Fuel systems & components  
Fuel tank inerting systems  
Hydraulic systems & components  
Thermal management  
Wheels & brakes



**Climate Control**  
**Key Markets**  
Agriculture  
Air conditioning  
Construction Machinery  
Food & beverage  
Industrial machinery  
Life sciences  
Oil & gas  
Precision cooling  
Process  
Refrigeration  
Transportation

**Key Products**  
Accumulators  
Advanced actuators  
CO<sub>2</sub> controls  
Electronic controllers  
Filter driers  
Hand shut-off valves  
Heat exchangers  
Hose & fittings  
Pressure regulating valves  
Refrigerant distributors  
Safety relief valves  
Smart pumps  
Solenoid valves  
Thermostatic expansion valves

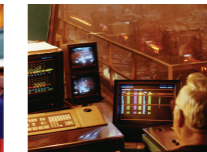

**Electromechanical**  
**Key Markets**  
Aerospace  
Factory automation  
Life science & medical  
Machine tools  
Packaging machinery  
Paper machinery  
Plastics machinery & converting  
Primary metals  
Semiconductor & electronics  
Textile  
Wire & cable

**Key Products**  
AC/DC drives & systems  
Electric actuators, gantry robots & slides  
Electrohydraulic actuation systems  
Electromechanical actuation systems  
Human machine interface  
Linear motors  
Stepper motors, servo motors, drives & controls  
Structural extrusions



**Filtration**  
**Key Markets**  
Aerospace  
Food & beverage  
Industrial plant & equipment  
Life sciences  
Marine  
Mobile equipment  
Oil & gas  
Power generation & renewable energy  
Process  
Transportation  
Water Purification

**Key Products**  
Analytical gas generators  
Compressed air filters & dryers  
Engine air, coolant, fuel & oil filtration systems  
Fluid condition monitoring systems  
Hydraulic & lubrication filters  
Hydrogen, nitrogen & zero air generators  
Instrumentation filters  
Membrane & fiber filters  
Microfiltration  
Sterile air filtration  
Water desalination & purification filters & systems



### Fluid & Gas Handling

**Key Markets**  
Aerial lift  
Agriculture  
Bulk chemical handling  
Construction machinery  
Food & beverage  
Fuel & gas delivery  
Industrial machinery  
Life sciences  
Marine  
Mining  
Mobile  
Oil & gas  
Renewable energy  
Transportation

**Key Products**  
Check valves  
Connectors for low pressure fluid conveyance  
Deep sea umbilicals  
Diagnostic equipment  
Hose couplings  
Industrial hose  
Mooring systems & power cables  
PTFE hose & tubing  
Quick couplings  
Rubber & thermoplastic hose  
Tube fittings & adapters  
Tubing & plastic fittings



### Hydraulics

**Key Markets**  
Aerial lift  
Agriculture  
Alternative energy  
Construction machinery  
Forestry  
Industrial machinery  
Machine tools  
Marine  
Material handling  
Mining  
Oil & gas  
Power generation  
Refuse vehicles  
Renewable energy  
Truck hydraulics  
Turf equipment

**Key Products**  
Accumulators  
Cartridge valves  
Electrohydraulic actuators  
Human machine interfaces  
Hybrid drives  
Hydraulic cylinders  
Hydraulic motors & pumps  
Hydraulic systems  
Hydraulic valves & controls  
Hydrostatic steering  
Integrated hydraulic circuits  
Power take-offs  
Power units  
Rotary actuators  
Sensors



### Pneumatics

**Key Markets**  
Aerospace  
Conveyor & material handling  
Factory automation  
Life science & medical  
Machine tools  
Packaging machinery  
Transportation & automotive

**Key Products**  
Air preparation  
Brass fittings & valves  
Manifolds  
Pneumatic accessories  
Pneumatic actuators & grippers  
Pneumatic valves & controls  
Quick disconnects  
Rotary actuators  
Rubber & thermoplastic hose & couplings  
Structural extrusions  
Thermoplastic tubing & fittings  
Vacuum generators, cups & sensors



### Process Control

**Key Markets**  
Alternative fuels  
Biopharmaceuticals  
Chemical & refining  
Food & beverage  
Marine & shipbuilding  
Medical & dental  
Microelectronics  
Nuclear Power  
Offshore oil exploration  
Oil & gas  
Pharmaceuticals  
Power generation  
Pulp & paper  
Steel  
Water/wastewater

**Key Products**  
Analytical instruments  
Analytical sample conditioning products & systems  
Chemical injection fittings & valves  
Fluoropolymer chemical delivery fittings, valves & pumps  
High purity gas delivery fittings, valves, regulators & digital flow controllers  
Industrial mass flow meters/controllers  
Permanent no-weld tube fittings  
Precision industrial regulators & flow controllers  
Process control double block & bleed  
Process control fittings, valves, regulators & manifold valves



### Sealing & Shielding

**Key Markets**  
Aerospace  
Chemical processing  
Consumer  
Fluid power  
General industrial  
Information technology  
Life sciences  
Microelectronics  
Military  
Oil & gas  
Power generation  
Renewable energy  
Telecommunications  
Transportation

**Key Products**  
Dynamic seals  
Elastomeric o-rings  
Electro-medical instrument design & assembly  
EMI shielding  
Extruded & precision-cut, fabricated elastomeric seals  
High temperature metal seals  
Homogeneous & inserted elastomeric shapes  
Medical device fabrication & assembly  
Metal & plastic retained composite seals  
Shielded optical windows  
Silicone tubing & extrusions  
Thermal management  
Vibration dampening

All the instruments meet the guidelines of the European Community (EU). It is confirmed that these products are approved acc. to following standards.



DIN/EN 61000-6-2  
DIN/EN 61000-6-3

#### Note!

This document and other information from Parker Hannifin GmbH, provide product or system options for further investigation by users having technical expertise. Before you select or use any product or system it is important that you analyse all aspects of your application and review the information concerning the product or system in the current product catalogue. Due to the variety of operating conditions and applications for these products or systems, the user, through his own analysis and testing, is solely responsible for making the final selection of the products and systems and assuring that all performance and safety requirements of the application are met. The products are subject to change by Parker Hannifin GmbH at any time without notice.

Technical subject to change. October 2019.

© Copyright 2019, Parker Hannifin Corporation. All Rights Reserved.









## Table of Contents

	Page
Product overview	4-5
Selection guide pressure sensors	6
Selection guide pressure controller	7
<b>Pressure and temperature sensors</b>	<b>9-35</b>
SCP01 pressure sensor	12-15
SCP02 pressure sensor	16-21
SCP07 pressure sensor	22-23
SCP08 pressure sensor	24-25
SCPS01 pressure switch	26-30
SCT-150 temperature sensor	31-32
<b>Volumetric flow rate sensors</b>	<b>33-48</b>
SCQ flow meter	35-38
SCFT measurement turbine	39-42
SCVF volume counter	43-48
<b>Digital display units</b>	<b>49-52</b>
SCE-020 digital display unit	49-52
<b>The Controller Family</b>	<b>53-100</b>
SCPSDi PressureController	55-60
SCPSD PressureController	61-66
SCTSD TemperatureController	67-78
SCTSD-L combination switch	79-82
SCLSD LevelController	83-88
SCLTSD LevelTempController	89-94
SCOTC OilTankController	95-100
<b>Accessories</b>	<b>101-106</b>
SCK cable	101-102
SCA adapter	103-104
Software ControllerWIN	105-106
<b>Installation and safety instructions</b>	<b>107</b>
EMC	107
Compatibility with media (substances)	107
Pressure range selection	107
<b>Appendix</b>	<b>108-109</b>
Conversion charts	108
Index	109
Old and new references	109



# Product overview

## Measurement

### Pressure and temperature sensors

SCP01	SCP02	SCP07
		
Pressure sensor for standard applications Page 12-15	Pressure sensor for mobile hydraulics Page 16-21	Pressure sensor for safety requirements Page 22-23
SCP08	SCPS01	SCT-150
		
Pressure sensor for press construction and die-casting Page 24-25	Pressure switch for series machines Page 26-30	Temperature sensor for high operating pressures Page 31-32

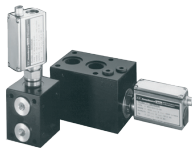
### Volumetric flow rate sensors

SCQ	SCFT	SCVF
		
For quick flow changes Measures in both directions Page 35-38	Low loss measuring of volume flow Page 39-42	Measures different substances Measures lower volume flows (leakage measurements) Page 43-48

## Displays





### Digital display units

SCE-020



Displays a variety of measured values Page 49-52

# Product overview

## Measurement, display and switching

	SCPSDi	SCPSD	SCTSD	SCTSD-L
<b>The Controller Family</b>				
	Pressure display and monitoring		Temperature display and monitoring	Temperature display and level monitoring
	Page 55-60	Page 61-66	Page 67-78	Page 79-82

	SCLSD	SCLTSD	SCOTC
			
	Level display and monitoring	Level/temperature display and monitoring	
	Page 83-88	Page 89-94	Page 95-100

## Accessories

SCK cable	SCA adapter	Software ControllerWIN
		
Page 101-102	Page 103-104	Page 105-106

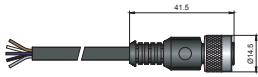
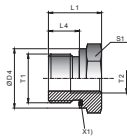
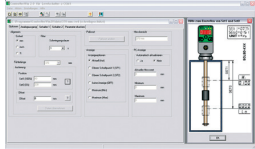
## Selection guide pressure sensors

		SCP01	SCP02	SCP07	SCP08	SCPS01
<b>Pressure-range</b>	0...(bar) relative -1...(bar) relative 0...(bar) absolut	10...1000	10...1000	10...600	600/1000	25...800
<b>Accuracy</b>		0,5 %	0,5 %	0,5 %	0,5 %	0,3...8 bar
<b>Display</b>						
<b>Output</b>	Switching Output 0,5...4,5 V (ratiometric 5V) 0,5...4,5 V (nominal 24V) 0...5 V 1...6 V 0...10 V 0...20 mA 4...20 mA (3-wire) 4...20 mA (2-wire)		•			•
<b>Electrical Plug</b>	M12 DIN EN 175301-803 Form A DIN Micro 9.4 AMP Superseal Deutsch DT04 4-pin Deutsch DT04 3-pin Cable 2m	•	•	•	•	•
<b>Thread</b>	G1/4 BSPP ED G 1/4 O-ring 1/4 NPT 7/16-20 UNF 9/16-20 UNF	•	•	•	•	•
<b>Wetted parts</b>	Stainless steel/ Soft sealing Stainless steel/ Metall sealing	FKM	FKM	FKM	FKM	FKM
<b>Approvals</b>	CE Marine Safety SIL / PL	•	•	•	•	•

## Selection guide pressure controller

		SCPSD	SCPSDi
<b>Pressure-range</b>	0...(bar) relative -1...(bar) relative 0...(bar) absolut		
<b>Accuracy</b>			
<b>Display</b>		•	•
<b>Output</b>	Switching Output 0,5...4,5 V (ratiometric 5V) 0,5...4,5 V (nominal 24V) 0...5 V 1...6 V 0...10 V 0...20 mA 4...20 mA (3-wire) 4...20 mA (2-wire)	•      •	•     • • •
<b>Electrical Plug</b>	M12 DIN EN 175301-803 Form A DIN Micro 9.4 AMP Superseal Deutsch DT04 4-pin Deutsch DT04 3-pin Cable 2m	• •	•
<b>Thread</b>	G1/4 BSPP ED G 1/4 O-Ring 1/4 NPT 7/16-20 UNF 9/16-20 UNF		
<b>Wetted parts</b>	Stainless steel/ Soft sealing Stainless steel/ Metall sealing	<b>NBR</b>  •	<b>NBR</b>  •
<b>Approvals</b>	CE Marine Safety SIL / PL	• •	• •

# Certified sensors and switches for maritime applications



The products designed for maritime use meet the current international approvals:

- **ABS** American Bureau of Shipping
- **DNV** Det Norske Veritas
- **GL** Germanischer Lloyd

The portfolio extends from pressure sensors to electronic switches with display for pressure / level / temperature. Parker offers the chance to upgrade from mechanical to electronic measuring devices in the hydraulic system, with the following advantages:

- |                 |                          |
|-----------------|--------------------------|
| ■ High accuracy | ■ Safety                 |
| ■ Long lifetime | ■ Comfortable functions  |
| ■ Reliability   | ■ High quality standards |

These certified products will enhance the safety and reliability of maritime hydraulic systems:

**SCP01/ SCPSD / SCPSDi / SCLTSD / SCTSD-L**



# Pressure and temperature sensors

## Device features

- Long-term stability
- Immune to interference
- Rugged design
- Dependable



Pressure and temperature sensors

**SensoControl®** sensors feature long-term stability, interference immunity, a sturdy high-quality construction and a wide range of variants.

The sensors are designed and manufactured in our own production facilities under established standards for the industrial instrumentation and control systems. This allows us to easily adapt them to customer requirements or to critical applications.

We carefully consider the special requirements for automation and mobile hydraulics during the design phase. So our **SensoControl®** sensors are ideally suitable for the permanent series use in industrial and mobile applications.

### Pressure sensors

The housing and all parts of the pressure sensors that touch the substances are manufactured from stainless steel. This provides a large range of media tolerability. A wide range of applications is possible due to the combination of high interference immunity and high resistance to external influences (shock, vibration and temperature).

The application areas are varied: from process engineering test rigs, conveying and lifting equipment, mobile hydraulics, general machine construction, pneumatic construction and hydraulic plant construction.

The SCP should be used when the pressure needs to be monitored reliably for long periods.

In this case the optimal sensor type can be selected from different product series according to the needs of the application. Different connecting plugs, output signals and connection threads are also available.

### Temperature sensors



The SCT temperature sensor should be used when a temperature signal is required.

These are characterised by their pressure resistance up to 630 bar.

# Pressure and temperature sensors

Pressure and temperature sensors

## Overview

	SCP01	SCP02	SCPS07
			
<b>Range of use</b>	Pressure sensor for standard applications <ul style="list-style-type: none"> <li>Stainless steel measuring cell</li> <li>Small design</li> <li>High burst pressure</li> <li>Resistant to pressure peaks</li> <li>Resistant to shock and vibration</li> </ul>	Pressure sensor for mobile hydraulics <ul style="list-style-type: none"> <li>Stainless steel measuring cell</li> <li>Small design</li> <li>Stainless steel housing</li> <li>High burst pressure</li> <li>ECE approval E1</li> <li>High protection degree</li> <li>Resistant to shock and vibration</li> </ul>	Pressure sensor for safety requirements <ul style="list-style-type: none"> <li>PLd</li> <li>SIL 2</li> <li>Two inverted 4-20 mA outputs</li> <li>Up to 600 bar</li> <li>G1/4 DIN 3852-11 (E)</li> <li>Compact design</li> <li>Long term stability</li> <li>Wide temperature range -40 to 85°C</li> </ul>
<b>Application</b>	<ul style="list-style-type: none"> <li>General machine construction</li> <li>Injection-mould machines</li> <li>Die-casting machines</li> <li>Press construction</li> <li>Test benches</li> <li>Machine tool</li> </ul>	<ul style="list-style-type: none"> <li>Mobile hydraulics</li> <li>Transport vehicles</li> <li>Conveyor vehicles</li> <li>Commercial vehicles</li> <li>Automotive technology</li> <li>Brake systems</li> <li>Oil pressure</li> <li>Test equipment and technology</li> <li>Gearbox control</li> </ul>	<ul style="list-style-type: none"> <li>Safety requirements</li> <li>Mobile hydraulic</li> <li>Cranes</li> <li>Suspended loads</li> <li>Tire presses</li> </ul>
<b>Order code</b>	SCP01-xxxxP-xx-0x	SCP02-xxx-xx-0x	SCP07-xxx-24-05
<b>Refer to page</b>	12-15	16-21	22-23

## Pressure and temperature sensors

### SCP08



### SCPS01



<b>Range of use</b>	Pressure sensor for press construction and die-casting <ul style="list-style-type: none"> <li>■ 600 / 1000 bar</li> <li>■ G1/4"</li> <li>■ 0-10 V / 4...20 mA 2-wire</li> <li>■ M12x1 / DIN</li> <li>■ Reinforced internal design</li> <li>■ Persistence against shock &amp; vibration</li> <li>■ Made for high pressure acceleration</li> <li>■ High dynamic signal</li> </ul>	Pressure switch for series machines <ul style="list-style-type: none"> <li>■ Stainless steel measuring cell</li> <li>■ Small design</li> <li>■ High burst pressure</li> <li>■ E1 road approval</li> <li>■ Resistant to pressure peaks</li> <li>■ Resistant to shock and vibration</li> </ul>
<b>Application</b>	<ul style="list-style-type: none"> <li>■ Press construction</li> <li>■ Die-casting</li> </ul>	<ul style="list-style-type: none"> <li>■ Construction machines</li> <li>■ Commercial vehicles</li> <li>■ Press construction</li> <li>■ Wind power facilities</li> <li>■ Injection-mould machines</li> <li>■ Tool-making machines</li> <li>■ Hydraulic power unit</li> <li>■ Special machine construction</li> <li>■ Replacement for mechanical pressure switches</li> </ul>
<b>Order code</b>	SCP08-xxxx-x4-0x	SCPS01-xxx-xx
<b>Refer to page</b>	24-25	26-30

### SCT-150



<b>Range of use</b>	Measurement of pressure even under high operating pressures <ul style="list-style-type: none"> <li>■ Resistance to pressures up to 630 bar</li> <li>■ Compact size</li> <li>■ Standard output signal</li> <li>■ Quick reaction time</li> </ul>
<b>Application</b>	<ul style="list-style-type: none"> <li>■ Test benches</li> <li>■ Processing equipment</li> <li>■ Conveying and lifting equipment</li> <li>■ Machinery construction</li> <li>■ Pneumatic plant construction</li> <li>■ Hydraulic plant construction</li> </ul>
<b>Order code</b>	SCT-150-41-07
<b>Refer to page</b>	31-32

# SCP01 pressure sensor

## Device features

- Small design
- Stainless steel measuring cell
- Stainless steel housing
- Shock and vibration proof
- Wide range of compatible substances
- High linearity
- Long-term stability
- Substance temperature -40...125 °C
- Pressure range up to 1000 bar
- High burst pressure
- Response time 1 ms
- Eroding milling
- Encapsulated electronics



The SCP01 pressure sensor was designed to meet industrial requirements and is used in control, regulating and monitoring systems.

The SCP01 is characterised by its compact design, high linearity and excellent interference immunity. It is suitable for quick control solutions because of its fast response speed. The compact stainless steel housing is good for harsh environmental conditions. All components which come into contact with the substance are made from stainless steel. This feature, combined with the welded, thin-layer measuring cell, ensure optimal compatibility with the substance.

In order to ensure an exact pressure measurement and to avoid disturbances, an EDM hole is integrated. This minimises the cavitation of air and dirt, thus preventing the measuring cell from being influenced by pressure surges and pressure peaks.

This product is ideal for permanent series usage in hydraulic applications because of its long lifespan, high accuracy, high reliability and sturdy stainless steel construction.

## Typical application range

- General machine construction
- Injection-mould machines
- Die-casting machines
- Press construction
- Test benches
- Machine tool

# SCP01 pressure sensor

## Technical data

**SCP01-xxx-x4-0x** (bar; G1/4" BSPP)

SCP01-	010	016	025	040	060	100	160	250	400	600	1000
Pressure range $P_n$ relative 0... (bar)	10	16	25	40	60	100	160	250	400	600	1000
Overload pressure* $P_{max}$ relative (bar)	2 x $P_n$										1.5 x $P_n$
Burst pressure** $P_{burst}$ relative (bar)	4 x $P_n$										2.5 x $P_n$

**SCP01-xxxxP-x5-0x** (psi; 1/4 NPT) & **SCP01-xxxxP-x7-0x** (psi; 7/16-20 UNF)

SCP01-	0150P	0250P	1000P	3000P	5000P	9000P***
Pressure range $P_n$ relative 0... (psi)	150	250	1000	3000	5000	9000
Overload pressure* $P_{max}$ relative (psi)	2 x $P_n$					
Burst pressure** $P_{burst}$ relative (psi)	4 x $P_n$					

\* DIN EN 60770-1 / \*\* DIN 16086 / \*\*\* only 1/4 NPT

General	
Response time	≤1 ms
Long-term stability	< 0.2 % FS / a
Load change	> 20 million
Weight	Approx. 80 g
MTTFd	> 100 years
Accuracy	
Non-linearity	BFSL acc. to IEC 61298-2 ≤± 0.25 %FS
Accuracy	Type ≤± 0.25 %FS Max. ≤± 0.5 %FS
Total error at 0 to 85 °C	≤±1 %FS
Temperature coefficient	
Zero point	Max. ≤± 0.2 %FS/10 K
Output range	Max. ≤± 0.2 %FS/10 K
Material	
Housing	Stainless steel 1.4404

Ambient conditions	
Ambient temperature range	-40...+85 °C
Fluid temperature range	-40...+125 °C
Compensated range	0...+85 °C
Storage temperature	-40...+125 °C
Vibration resistance	IEC 60068-2-6: 20 g
Shock resistance	IEC 60068-2-27: 500 g
Electrical protection	
Short-circuit, signal to GND, reverse polarity protection	
EM compatibility	
Disturbance emissions	EN 61000-6-3
Resistance to interference	EN 61000-6-2
Process connection	
Eroding milling	0.6 mm
Tightening torque	Max. 35 Nm

Process connection	Seal	Parts in contact with substances
G1/4A BSPP; DIN 3852 T11, Form E	Sealing ring DIN 3869-14-FKM	FKM Stainless steel 1.4404, Stainless steel 1.4548
SAE 7/16 UNF Male O-ring	O-ring 8,12x1,83 FKM	FKM Stainless steel 1.4404, Stainless steel 1.4548
1/4 NPT		Stainless steel 1.4404, Stainless steel 1.4548

Output signal	0...20 mA	2-wire 4...20 mA	4...20 mA	0.5...4.5 V (nom); 0...5 V; 1...6 V; 0...10 V
Auxiliary power $V_+$	+9...36 VDC	+9...36 VDC	+9...36 VDC	+14...36 VDC
Max. load	≥50...≤500 Ω ( $V_+ - 9 V$ ) / 20 mA	≥50...≤500 Ω ( $V_+ - 9 V$ ) / 20 mA	≥50...≤500 Ω ( $V_+ - 9 V$ ) / 20 mA	≥10 kΩ



# SCP01 pressure sensor

Pressure and temperature sensors

## Pin assignment

Device plug DIN EN 175301-803 Form A 4-pole (old 43650)

SCP01-...-06			SCP01-...-06-MA	
PIN	2-wire 4...20 mA	3-wire 0/4...20 mA; 0.5...4.5 V (nom); 0...5 V; 0...10 V; 1...6 V	2-wire 4...20 mA	3-wire 0/4...20 mA; 0...10 V
1	P-signal	P-signal	V <sub>+</sub>	V <sub>+</sub>
2	n.c.*	0 V / GND	n.c.*	0 V / GND
3	V <sub>+</sub>	V <sub>+</sub>	P-signal	P-signal
	n.c.*			
Protection class			IP65	

Circular connector M12x1 4-pole

SCP01-...-07		
PIN	2-wire 4...20 mA	3-wire 0/4...20 mA; 0.5...4.5 (nom); 0...5 V; 0...10 V; 1...6 V
1	V <sub>+</sub>	V <sub>+</sub>
2	P-signal	P-signal
3	n.c.*	0 V / GND
4	n.c.**	
Material		Metall plug
Protection class		IP67

Device plug (L-Industrial 9.4 mm)

SCP01-...-0C		
PIN	2-wire 4...20 mA	3-wire 0/4...20 mA; 0.5...4.5 (nom); 0...5 V; 0...10 V; 1...6 V
1	P-signal	P-signal
2	V <sub>+</sub>	V <sub>+</sub>
3	n.c.*	
	n.c.*	0 V / GND
Protection class		IP65

\*n.c. = do not connect

\*\*n.c. = do not connect / When flying leads are used on PIN 4, the PIN 4 has to be connected to GND.

**SCP01-...-x4-0x**

G1/4 BSPP ED

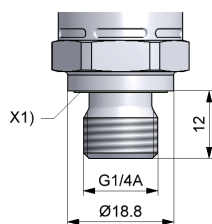

X1) = ED-seal

**SCP01-...-x5-0x**

1/4 NPT

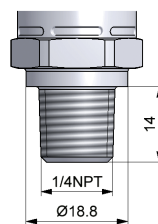

**SCP01-...-x7-0x**

SAE 7/16-20UNF

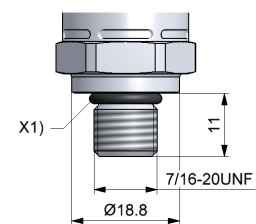

X1) = O ring 8.92 x 1.83



# SCP01 pressure sensor

## SCP01-xxx-xx-07

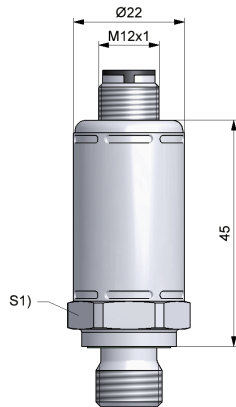

S1) = SW22

## SCP01-xxx-xx-06

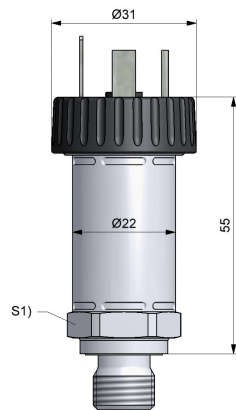

S1) = SW22

## SCP01-xxx-xx-0C

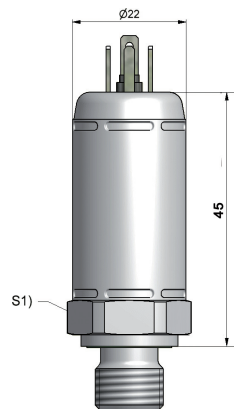

S1) = SW22

## Order code

Pressure sensor SCP01 (bar) SCP01-xxx-xx-0x  
 Pressure sensor SCP01 (bar) Marine SCP01-xxx-xx-0x-MA  
 (approved by DNV/GL/ABS)

Pressure range (bar)	Order code
0...10 bar	010
0...16 bar	016
0...25 bar	025
0...40 bar	040
0...60 bar	060
0...100 bar	100
0...160 bar	160
0...250 bar	250
0...400 bar	400
0...600 bar	600
0...1000 bar	1000

Output signal	Order code
0...20 mA	1
4...20 mA (3-wire)	2
4...20 mA (2-wire)	3
0...5 V*	A
0,5...4,5 V (nom)*	S
1...6 V*	B
0...10 V	4

\*Not approved for marine applications

Process connection	Order code
G 1/4" BSP	4

Connection plug	Order code
Circular connector M12x1 4-pole	7
Device connector DIN EN 175301-803 Form A 4-pole	6
Device plug industrial micro DIN 9.4 mm	C

Pressure sensor SCP01 (psi) SCP01-xxxxP-xx-0x

Pressure range (psi)	Order code
0...150 psi	0150P
0...250 psi	0250P
0...1000 psi	1000P
0...3000 psi	3000P
0...5000 psi	5000P
0...9000 psi	9000P

Output signal	Order code
4...20 mA (3-wire)	2
4...20 mA (2-wire)	3
0...10 V	4

Process connection	Order code
SAE 7/16 UNF Male O ring (P <sub>n</sub> max. = 400 bar)	7
1/4 NPT (P <sub>n</sub> max. = 600 bar)	5

Connecting plug	Order code
Circular connector M12x1 4-pole	7

Pressure and temperature sensors



## SCP02 pressure sensor

### Device features

- Small design
- Stainless steel measuring cell
- Stainless steel housing
- Shock and vibration proof
- High protection degree
- E1 road approval
- Substance temperature -40 to 150 °C
- Up to 1000 bar
- 1 ms
- Up to 36-V wiring systems



The SCP02 was designed specifically for the use in mobile working machines. The SCP02 has e1-approval and is manufactured with state of the art production methods according to ISO/TS 16949.

The shock and vibration resistance, the EMC characteristics, the power supply as well as the extended temperature range all were designed for this application type.

The SCP02 is suitable for quick control solutions because of its fast response speed.

The compact stainless steel housing with the plastic connector allows for use in harsh environmental conditions such as those in mobile hydraulics.

The components which come into contact with the substance are made from stainless steel (1.4548). This feature, combined with the welded, thin-layer measuring cell, ensures optimal compatibility with the substance.

An EDM hole has been added so that you get a precise, interference-free pressure measurement. This minimises the cavitation of air and dirt, thus preventing the measuring cell from being influenced by pressure surges and pressure peaks.

### Typical application range

- Mobile hydraulics
- Transport vehicles
- Conveyor vehicles
- Commercial vehicles
- Automotive technology
- Brake systems
- Oil pressure
- Test equipment and technology
- Gearbox control

# SCP02 pressure sensor

## Technical data

SCP02-	010	025	040	060	100	160	250	400	600	1000
Pressure range $P_n$ relative 0... (bar)	10	25	40	60	100	160	250	400	600	1000
Overload pressure* $P_{max}$ relative (bar)	2 x $P_n$									1.5 x $P_n$
Burst pressure** $P_{burst}$ relative (bar)	4 x $P_n$									2.5 x $P_n$

\* DIN EN 60770-1

\*\* DIN 16086

General	
Response time	≤1 ms
Long-term stability	< 0.2 % FS / a
Load change	> 100 million
Weight	Approx. 55 g
MTTFd	> 100 years
Accuracy	
Linearity, pressure hysteresis and reproducibility	≤0.5 %FS
Complete accuracy	≤1.0 %FS (0...+80 °C) ≤1.5 %FS (-25...+100 °C) ≤2.5 %FS (-40...+125 °C)
Temperature coefficient	
Zero point	Max. ≤± 0.2 %FS/10 K
Output range	Max. ≤± 0.2 %FS/10 K
Material	
Housing	EN/DIN 1.4301
Electrical plug	Plastic PBT-GF30 Ultradur B4300 G6 black

Ambient conditions	
Ambient temperature range	-40...+125 °C
Fluid temperature range	-40...+150 °C
Storage temperature	-40...+125 °C
Vibration resistance	IEC 60068-2-6: 20 g
Shock resistance	IEC 60068-2-27: 500 g
Electrical protection	
Short circuit, signal against GND/0V and protection against polarity reversal (not with ratiometric output)	
EM compatibility	
Disturbance emissions	EN 61000-6-3
Resistance to interference	EN 61000-6-2
Process connection	
Eroding milling	0.6 mm
Tightening torque	Max. 35 Nm

Process connection	Seal	Parts in contact with substances	Max. pressure range $P_n$
G1/4A BSPP; DIN 3852 T11, Form E	Sealing ring DIN 3869-14-FKM	EN/DIN 1.4548 / FKM	1000 bar
SAE-4: 7/16-20 UNF O-ring	O-ring FKM	EN/DIN 1.4548 / FKM	400 bar
SAE 6: 9/16-18 UNF O-ring	O-ring FKM	EN/DIN 1.4548 / FKM	400 bar
G1/4 DIN ISO 228-1 O-ring	O-ring FKM	EN/DIN 1.4548 / FKM	600 bar
1/4 NPT		EN/DIN 1.4548	600 bar

Output signal P signal	2-wire 4...20 mA	0...5 V; 1...6 V 0.5...4.5 V nom.	0...10 V	0.5...4.5 V ratiometric
Auxiliary power $V_+$	+9...36 VDC	+9...36 VDC	+14...36 VDC	5 V
Load $\Omega$ (Ohm)	≥50...≤500 $\Omega$ ( $V_+ - 9 V$ ) / 20 mA	≥10 k $\Omega$	≥10 k $\Omega$	≥10 k $\Omega$



# SCP02 pressure sensor

Pressure and temperature sensors

## Pin assignment

### AMP Superseal 1.5

SCP02-xxx-xx-0A

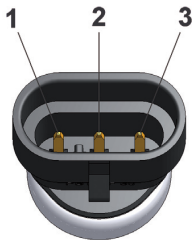

PIN	2-wire 4...20 mA	0...5 V; 1...6 V; 0.5...4.5 V nom.; 0...10 V	0.5...4.5 V ratiometric
1	P-signal	0 V / GND	0 V / GND
2	n.c.*	P-signal	P-signal
3	V <sub>+</sub>	V <sub>+</sub>	V <sub>+</sub>

Material Plastic PBT-GF30 Ultradur B4300 G6 black  
Protection class IP67

### DT04-4P

SCP02-xxx-xx-0D

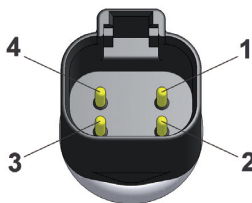

PIN	2-wire 4...20 mA	0...5 V; 1...6 V; 0.5...4.5 V nom.; 0...10 V	0.5...4.5 V ratiometric
1	V <sub>+</sub>	V <sub>+</sub>	V <sub>+</sub>
2	P-signal	0 V / GND	0 V / GND
3	n.c.*	P-signal	P-signal
4	n.c.*	n.c.*	n.c.*

Material Plastic PBT-GF30 Ultradur B4300 G6 black  
Protection class IP67

### DT04-3P

SCP02-xxx-xx-0E

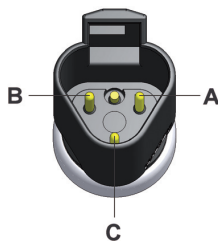

PIN	2-wire 4...20 mA	0...5 V; 1...6 V; 0.5...4.5 V nom.; 0...10 V	0.5...4.5 V ratiometric
A	V <sub>+</sub>	V <sub>+</sub>	V <sub>+</sub>
B	n.c.*	P-signal	P-signal
C	P-signal	0 V / GND	0 V / GND

Material Plastic PBT-GF30 Ultradur B4300 G6 black  
Protection class IP67

### 2 m fixed cable

SCP02-xxx-xx-00



	2-wire 4...20 mA	0...5 V; 1...6 V; 0.5...4.5 V nom.; 0...10 V	0.5...4.5 V ratiometric
bn	V <sub>+</sub>	V <sub>+</sub>	V <sub>+</sub>
black	n.c.*	P-signal	P-signal
blue	P signal	0 V / GND	0 V / GND

Material Plastic PBT-GF30 Ultradur B4300 G6 black  
Protection class IP69k

bn = brown-braun / bk = black-schwarz / bu = blue-blau  
\*n.c. = do not connect



# SCP02 pressure sensor

## Pin assignment

M12x1

SCP02-xxx-xx-x5

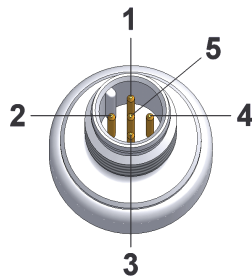

PIN	2-wire 4...20 mA	0...5 V; 1...6 V 0.5...4.5 V nom.; 0...10 V	0.5...4.5V ratiometric	CAN-Assignment
1	V <sub>+</sub>	V <sub>+</sub>	V <sub>+</sub>	CAN shield, PE
2	P-signal	P-signal	P-signal	+U <sub>B</sub> , +24 VDC
3	n.c.*	0 V / GND	0 V / GND	GND, 0 V
4	n.c.*	n.c.*	n.c.*	CAN_H, CAN+
5	n.c.*	n.c.*	n.c.*	CAN_L, CAN-

Material

Plastic PBT-GF30 Ultradur B4300 G6 black

Protection class

IP67

\*n.c. = do not connect

Pressure and temperature sensors

SCP02-xxx-xx-0A

AMP Superseal

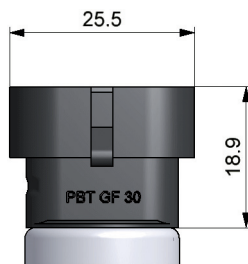

SCP02-xxx-xx-0D

DT04-4P

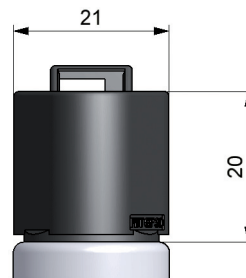

SCP02-xxx-xx-0E

DT04-3P

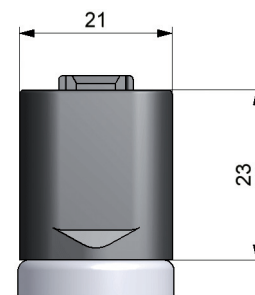

SCP02-xxx-xx-05

M12x1

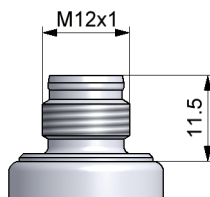

SCP02-xxx-xx-00

Stationary cable (2 m)

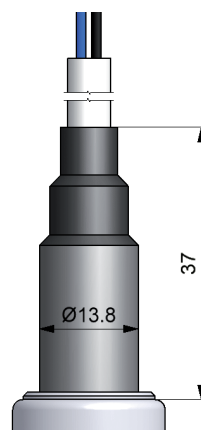

# SCP02 pressure sensor

Pressure and temperature sensors

### SCP02-xxx-x4-0x

G 1/4, DIN 3852 T 11 (Form E)

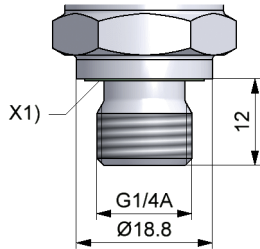

X1) = ED-seal

### SCP02-xxx-x8-0x

G1/4 O-ring

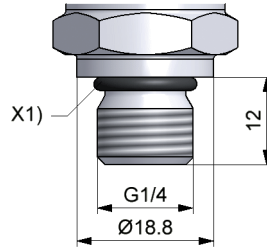

X1) = O-ring

### SCP02-xxx-x5-0x

1/4 NPT

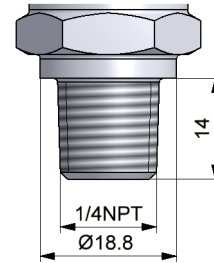

### SCP02-xxx-x7-0x

SAE 04 - O-ring

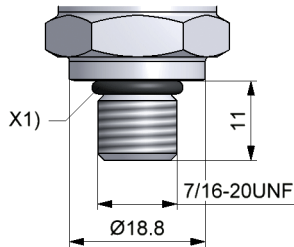

X1) = O-ring 8.92x1.83

### SCP02-xxx-x6-0x

SAE 06 - O-ring

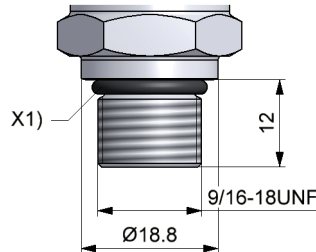

X1) = O-ring 11.89x1.98

### SCP02-xxx-xx-0x

M12x1

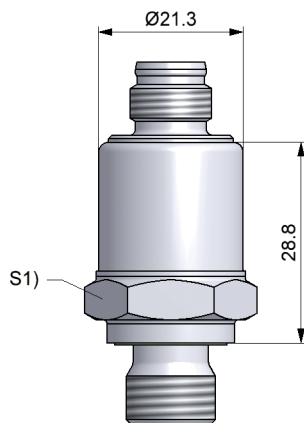

S1) = SW22



# SCP02 pressure sensor

## Order code

<b>Pressure sensor SCP02</b>	<b>SCP02-xxxx-xx-0x</b>
<b>Pressure range</b>	
0...10 bar	<b>010</b>
0...25 bar	<b>025</b>
0...40 bar	<b>040</b>
0...60 bar	<b>060</b>
0...100 bar	<b>100</b>
0...160 bar	<b>160</b>
0...250 bar	<b>250</b>
0...400 bar	<b>400</b>
0...600 bar	<b>600</b>
0...1000 bar	<b>1000</b>
<b>Output signal</b>	
4...20 mA (2-wire)	<b>3</b>
4...20 mA (3-wire)	<b>2</b>
0...10 V	<b>4</b>
0...5 V	<b>A</b>
1...6 V	<b>B</b>
0.5...4.5 V (ratiometric)	<b>R</b>
0.5...4.5 V (nom.)	<b>S</b>
CAN	<b>K</b>
<b>Process connection</b>	
G1/4 BSPP	<b>4</b>
1/4 NPT (P <sub>n</sub> max. = 600 bar)	<b>5</b>
9/16-18 UNF, SAE 6 O-ring (P <sub>n</sub> max. = 400 bar)	<b>6</b>
7/16-20 UNF SAE-4 O-ring (P <sub>n</sub> max. = 400 bar)	<b>7</b>
G1/4 O-ring (P <sub>n</sub> max. = 600 bar)	<b>8</b>
<b>Connecting plug</b>	
Stationary cable 1 m	<b>0</b>
Circular connector M12x1 5-pole	<b>5</b>
Device plug AMP Superseal	<b>A</b>
Device plug DT04 4-pole	<b>D</b>
Device plug DT04 3 pole	<b>E</b>

## Connection cable and single plug

<b>Connection cable, assembled</b> (open cable end)	<b>SCK-400-xx-xx</b>
<b>Cable length (m)</b>	
2 m	<b>02</b>
5 m	<b>05</b>
10 m	<b>10</b>
<b>Connecting plug</b>	
M12 cable jack; straight	<b>45</b>
M12 cable jack; 90° angled	<b>55</b>
<b>Single connector</b>	
M12 cable jack; straight	<b>SCK-145</b>
M12 cable jack; 90° angled	<b>SCK-155</b>

Pressure and temperature sensors

## Order example

**SCP02-400-34-05**  
 Single sensor  
 Pressure range 400 bar  
 Output signal 4 to 20 mA (2-wire)  
 G1/4 BSPP  
 M12 connecting plug 5-pole

## Pressure sensor SCP07

### Device features

- For safety requirements
- PLd
- SIL 2
- Two inverted 4-20 mA outputs
- Up to 600 bar
- G1/4 DIN 3852-11 (E)
- Compact design
- Long term stability
- Wide temperature range -40 to 85°C



The SCP07 is a safety-related pressure transmitter and can be used in applications that require a Performance Level d according to EN ISO13849 or a SIL 2 according to IEC61508.

The SCP07 supervises the signals of its measurement cell and convert the pressure in two inverted 4-20 mA output signals. The control unit can monitor the safety-related functionality and the electrical connectivity of the SCP07.

### Typical application range

- Mobile hydraulic
- Cranes
- Suspended loads
- Tire presses

# Drucksensor SCP07

## Technical data

SCP07-	010	025	060	100	250	400	600
Pressure range $P_n$ 0... (bar) relative	10	25	60	100	250	400	600
Overload pressure $P_{max}$ DIN EN 60770-1 (bar) relative	50	50	200	200	500	800	1600
Burst pressure $P_{burst}$ 60770-1 (bar) relative	250	250	1000	1000	2500	4000	>4000

General	
Response time	≤1 ms
Load change	>100 million
Material Housing	Stainless steel 1.4301
Weight	Approx. 50 g
Process Connection	G1/4, DIN 3852 T11 (E)
Material	Stainless steel 1.4548
Material diaphragm	Stainless steel 1.4548
Wetted parts	FKM Stainless steel 1.4548
Seal	ED Type: FKM
Installation torque	Max. 35 Nm

Ambient Conditions	
Media temperature	-40 to 125°C
Operation / Ambient temperature	-40 to 85°C
Storage temperature	-40 to 100°C
Vibration	IEC 60068-2-6 :20g
Shock	IEC 60068-2-27 :500g

Conformity	
CE	EN 61326-1, EN 61326-3-1
E1	All vehicle types with +12/24 V and battery (-) at the chassis

Accuracy Parameter	
Non-linearity + Hysteresis+Repeatability	≤0,5 %FS
Long-term stability	≤0,2 %FS / year

Overall Accuracy	
@ -40°C...-25°C	≤2,5 %FS
@ -25°C...0°C	≤1,5 %FS
@ 0...85°C	≤1 %FS

Safety classification	
IEC 61508:2010	SIL 2
Safety-related subsystem	Type B
Hardware architecture	1oo1
HFT	0
SFF (incl. control unit)	95 %
PFH	8,4 *10E-9
EN ISO 13849-1:2010	PLd
Category	2
DC (incl. control unit)	93,8 %
CCF	70
MTTF <sub>D</sub>	>100 years
MTBF (SN29500)	420,7 years

Electrical Connection		
Output signal	4...20 mA / 20...4 mA	
Supply voltage $V_+$	9...32 VDC ripple @50HZ 10 %	
Load <sub>max</sub>	$(V_+ - 5.5 V) / 0,02 A [\Omega]$	
Protection	Overvoltage	yes
	Short circuit	yes
	Reverse polarity	yes
	Signal on GND/ $V_+$	yes

M12x1		
Protection class IEC 60529 (mounted connector)	IP67	
Material	PBT-GF30	
	Pin 1	$V_+$
	Pin 2	20...4 mA
	Pin 3	GND
	Pin 4	4...20 mA
	Pin 5	Do not connect!

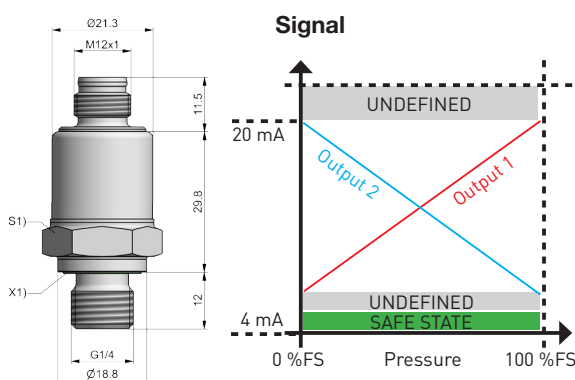
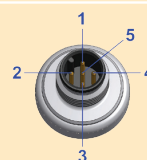

<b>Order code</b>	<b>Pressure sensor SCP07</b>	<b>SCP07-xxx-24-05</b>
<b>Pressure range</b>		
0...10 bar.....		<b>-010</b>
0...25 bar.....		<b>-025</b>
0...60 bar.....		<b>-060</b>
0...100 bar.....		<b>-100</b>
0...250 bar.....		<b>-250</b>
0...400 bar.....		<b>-400</b>
0...600 bar.....		<b>-600</b>



## Pressure sensor SCP08

### Device features

- 600 / 1000 bar
- G1/4"
- 0-10V / 4...20mA 2-wire
- M12x1 / DIN
- Reinforced internal design
- Persistence against shock & vibration
- Made for high pressure acceleration
- High dynamic signal



Particularly in die-casting applications the controlling for the piston requires a high dynamic pressure sensor. During this fast, high energetic process the components are stressed by shock, vibration and pressure acceleration.

The pressure sensor SCP08 measures the pressure via a special designed measurement cell and has a high adapted overload pressure to withstand the pressure peaks.

To avoid abrasion of the cell due to Diesel or similar effects, the process connection is protected by an adjusted drilling. The dimension of the drilling still guaranties an instantaneous pressure response.

To increase shock and vibration resistance, the relevant internal components are covered and reinforced. The speed of the sensor influences directly the quality of the production process.

The unique combination of accuracy, durability and high dynamic response makes the SCP08 ideal for the requirements of die-casting applications.

### Typical applications

- Press construction
- Die-casting

# Pressure sensor SCP08

## Technical data

SCP08-	600	1000
Pressure range $P_n$ 0... (bar) relative	600	1000
Overload pressure $P_{max}$ (bar) relative	1200	1500
Burst pressure $P_{burst}$ (bar) relative	1800	2000

General	
Response time	0...10 V $\leq 0,3$ ms 4...20 mA 2-Leiter $\leq 0,5$ ms*
Load change	>10 million.
Material Housing	Stainless steel 304
Weight	Approx. 80 g

Ambient Conditions	
Media temperature	-40 to 125°C
Operation- / Ambient temperature	-40 to 105°C
Storage temperature	-40 to 125°C
Vibration	20 g rms
Shock	1 m on concrete

Conformity	
CE	yes

Overall Accuracy	
@ RT *1	$\leq 0,5$ %FS
@ -10°C...85°C *1 *2	$\leq 2$ %FS
@ -40...105°C *1 *2	$\leq 2,5$ %FS
Long-term stability	$\leq 0,2$ %FS / year

\*1 incl. Non-linearity + Hysteresis + Offset + Gain  
\*2 incl. Repeatability + Temperature effects  
RT = Room Temperature 20°C

Process Connection	
Thread	G1/4, DIN 3852 T11 (E)
Eroding milling	0,6 mm
Volume measured	$< 1$ mm <sup>3</sup>
Seal	ED Type: FKM
Material	Stainless steel 17-4 PH
Material diaphragm	Stainless steel 17-4 PH
Wetted parts	FKM Stainless steel 17-4 PH

Installation	
Installation torque	Max. 35 Nm
General	no restriction
Recommended preventive activities to avoid air inclusion:	
<ul style="list-style-type: none"> <li>Bleed air</li> <li>Installation with Process connection on top</li> </ul>	

\*with 2 m cable

Output signal	0...10 V	4...20 mA 2-wire
Supply voltage $V_+$	12...32 VDC	10...32 VDC
Load <sub>max</sub>	10 k $\Omega$	( $V_+ - 10$ V) / 20 mA
Protection	Overvoltage	36 signal on GND/ $V_+$
	Short circuit	yes
	Reverse polarity	yes
	Signal on GND/ $V_+$	yes

M12x1			
Protection class (mounted connector)	IP67	0...10 V	4...20 mA 2-wire
	Pin 1	$V_+$	$V_+$
	Pin 2	P-signal	P-signal
	Pin 3	$V_-$	
	Pin 4		

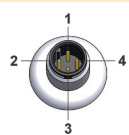

DIN EN 175301-803 Form A			
Protection class (mounted connector)	IP65	0...10 V	4...20 mA 2-wire
	Pin 1	$V_+$	$V_+$
	Pin 2	$V_-$	P-signal
	Pin 3	P-signal	
	Pin 4		

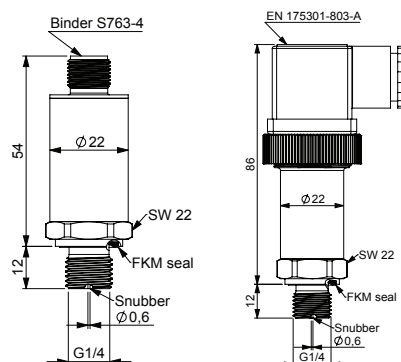
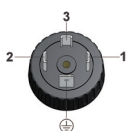

## Order code

Pressure sensor SCP-08  
4...20 mA; 2-wire

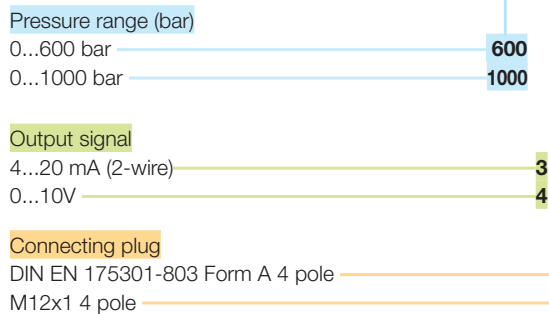

# SCPS01 pressure switch

Pressure and temperature sensors

## Device features

- Long service life
- No readjustment
- For harsh environments
- Accurate switching



The SCPS01 electronic pressure switches were designed to be used in mass-produced machines.

### Installation and production

In order to reduce the complexity of installation for the customer, the pressure switch can be programmed with customer-specific values at the factory. There is then no longer any need to make time-consuming adjustments while the system is pressurized.

### More safety for the equipment manufacturer

The pressure switch can be set-up by the equipment manufacturer using a software program. This prevents the switch from being manipulated by unauthorized end users.

### Components

This pressure switch contains no moveable parts. All components which come into contact with the substance are made from stainless steel. This feature, combined with the welded, thin-layer pressure sensor, ensure optimal compatibility with the substance. A cushioning mechanism can be optionally integrated in the substance inlet. The stainless steel housing enables the switch to be used in extremely harsh environments.

### Application area

The switches have been designed with EMC characteristics, shock resistance and vibration resistance so that they can be used in a wide variety of applications and with mobile machines.

They have e1 approval and the SCPS01 are therefore approved for use in public transportation vehicles.

Thanks to their sturdy, compact design, long-term stability, the SCPS01 are the alternative to mechanical pressure switches.

### Application examples

- Construction machines
- Commercial vehicles
- Press construction
- Wind power facilities
- Injection-mould machines
- Tool-making machines
- Power packs
- Special machine construction
- Replacement for mechanical pressure switches



# SCPS01 pressure switch

## Technical data

SCPS01-	025	060	100	250	400	600	800
Pressure range $P_n$ , relative (bar)	0...25 bar	0...60 bar	0...100 bar	0...250 bar	0...400 bar	0...600 bar	0...800 bar
Adjusting range RSP...SP (Lowest reset switch point ... highest switch point)							
Overload pressure* $P_{max}$ , relative (bar)	2 x $P_n$						
Bursting pressure** $P_{burst}$ , relative (bar)	4 x $P_n$						3 x $P_n$
Smallest adjustable difference between SP and RSP (SP-RSP)	0.3 bar	0.6 bar	1 bar	3 bar	4 bar	6 bar	8 bar

Information about selecting the pressure range

The system pressure and pressure value used for switching are relevant for pressure switches:

Since a 400-bar pressure switch has a comparable resolution as that of a 600-bar pressure switch,

it is possible to use a pressure switch with a higher pressure range of  $P_n$  600 bar – even when there is a smaller nominal pressure (for example, 315 bar).

This is a positive feature because it provides the same precision with improved safety (higher  $P_{max}$  over-pressure) and fewer product variants.

\* DIN EN 60770-1

\*\* DIN 160866

General	
Response time	Typ. 10 ms, max. 20 ms
Long-term stability	< 0.2 % FS / a
Switching cycles	> 100 million
Weight	Approx. 100 g
MTTFd	> 100 years
Accuracy	
Linearity, pressure hysteresis and reproducibility	≤0.5 %FS
Switching accuracy	≤1.0 % FS (0...+80 °C) ≤1.5 % FS (-25...+100 °C) ≤2.5 % FS (-40...+125 °C)
Ambient conditions	
Ambient temperature range*	-40...+125 °C
Temperature of substance	-40...+150 °C
Storage temperature	-40...+125 °C
Vibration resistance	IEC 60068-2-6: 20 g
Shock resistance	IEC 60068-2-27: 500g
EM compatibility	
Disturbance emissions	EN 61000-6-3
Resistance to interference	EN 61000-6-2

\* not for cable version

Electrical connection	
Plug	M12 plug; German DT04 Cable outlet 1 m
Supply voltage	9...36 VDC 10 % allowed residual ripple at 50 Hz
Current consumption	40 mA
Output signal	1x PNP, 2x PNP 1x NPN, 2x NPN
Output current	Max. 500 mA per switch output
Electrical protection	Short circuit, signal against GND/0 V and protection against polarity reversal
Protection degree	IP67 and IP69k (dependent on the electrical connection used)
Material	
Housing	Stainless steel EN/DIN 1.4301
Membrane	Stainless steel EN/DIN 1.4548
Parts in contact with substances	Stainless steel EN/DIN 1.4548 / FKM (replaceable seal) *
Process connection	
Connection	¼ BSP ; ¼ NPT**
Tightening torque	Max. 35 Nm

# SCPS01 pressure switch

Pressure and temperature sensors

## Pin assignment

### DT04-3P

SCPS01-xxx-xx-0E

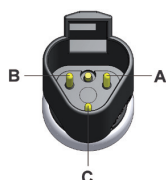

PIN	Assignment
A	V <sub>+</sub>
B	0 V / GND
C	S1 out
Housing	GND
Material	Plastic PBT-GF30 Ultradur B4300 G6 black
Protection class	IP67

### M12x1

SCPS01-xxx-xx-05

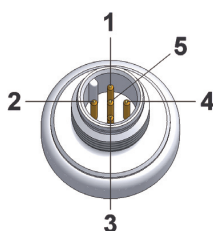

PIN	Assignment
1	V <sub>+</sub>
2	Out 2
3	0 V / GND
4	S1 out & Prog.
5	n.c.*
Housing	GND
Material	Plastic PBT-GF30 Ultradur B4300 G6 black
Protection class	IP67

Protection class IP67

\* n.c. = do not connect

### 2 m fixed cable

SCPS01-xxx-xx-00

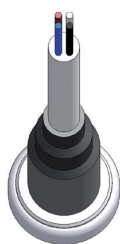

Cable	Assignment
bn	V <sub>+</sub>
black	S1 out & Prog.
blue	0 V / GND
white	Out 2
Housing	GND

Protection class IP69k

 bn = brown-braun / bk = black-schwarz /  
 bu = blue-blau / wh = white-weiß

## Software

### Adjustable parameters

- Each output individually adjustable
- Switching point / reset point
- Switching delay / reset delay
- NO/NC contact
- Hysteresis window

### Displayable parameters

- Pressure range
- Current pressure
- Serial number
- Firmware

### Standard setting

SP1 = 60 % FS rSP1 = 40 % FS

SP2 = 70 % FS rSP2 = 30 % FS

### Connection

USB 2.0

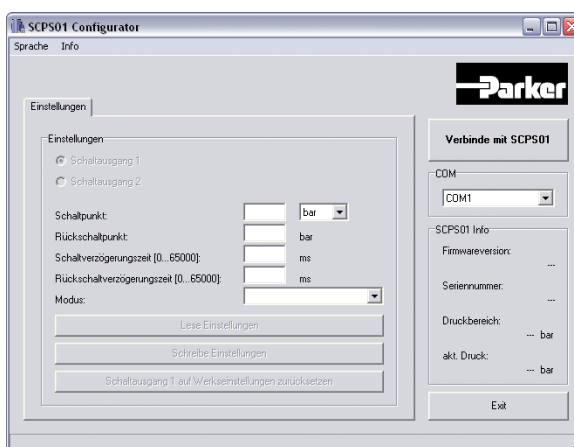

# SCPS01 pressure switch

Pressure and temperature sensors

## SCPS01-xxx-xx-0E

DT04-3P

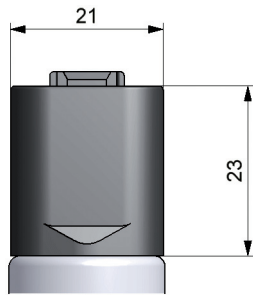

## SCPS01-xxx-xx-05

M12x1

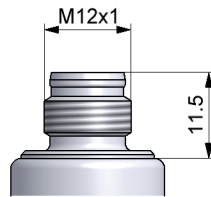

## SCPS01-xxx-xx-00

Stationary cable (2 m)

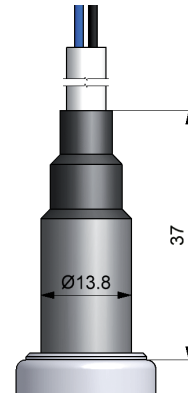

## SCPS01-xxx-x4-0x

G 1/4, DIN 3852 T 11 (Form E)

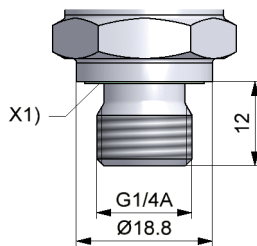

X1) = ED-seal

## SCPS01-xxx-x8-0x

G1/4 O ring

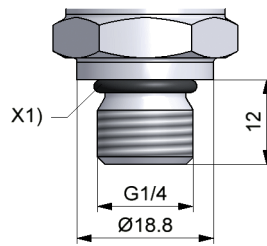

X1) = O ring

## SCPS01-xxx-x5-0x

1/4 NPT

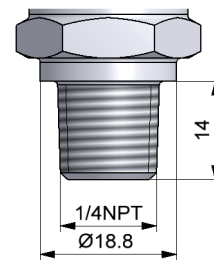

## SCPS01-xxx-x7-0x

SAE 04 - O ring

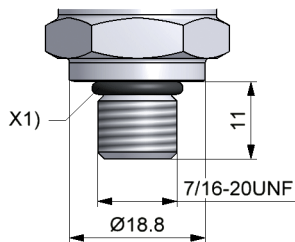

X1) = O ring 8.92x1.83

## SCPS01-xxx-x6-0x

SAE 06 - O ring

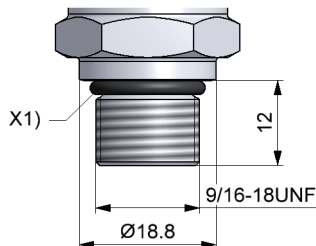

X1) = O ring 11.89x1.98

## SCPS01-xxx-xx-xx

M12x1

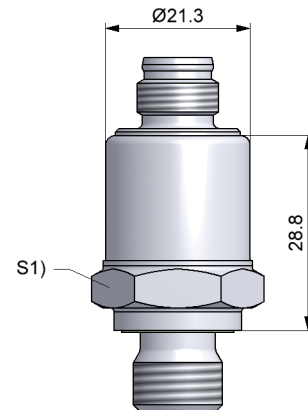

S1) = SW22

# SCPS01 pressure switch

Pressure and temperature sensors

## Order code

<b>Pressure sensor SCPS01</b>	<b>SCPS01-xxx-xx-0x</b>
<b>Pressure range</b>	
0...25 bar	<b>025</b>
0...60 bar	<b>060</b>
0...100 bar	<b>100</b>
0...250 bar	<b>250</b>
0...400 bar	<b>400</b>
0...600 bar	<b>600</b>
0...800 bar	<b>800</b>
<b>Output signal</b>	
1 x PNP	<b>1</b>
2 x PNP	<b>2</b>
1 x NPN	<b>3</b>
2 x NPN	<b>4</b>
<b>Process connection</b>	
G1/4 BSPP	<b>4</b>
1/4 NPT (P <sub>n</sub> max. = 600 bar)	<b>5</b>
9/16-18 UNF, SAE 6 O ring (P <sub>n</sub> max. = 400 bar)	<b>6</b>
7/16-20 UNF SAE-4 O ring (P <sub>n</sub> max. = 400 bar)	<b>7</b>
G1/4 O ring (P <sub>n</sub> max. = 600 bar)	<b>8</b>
<b>Connecting plug</b>	
Stationary cable 2 m	<b>0</b>
Circular connector M12x1 5-pole	<b>5</b>
Device plug DT04 3-pole	<b>E</b>

### Accessories

Programming kit with circular connector M12x1 5-pole **SCPS01-PRG-Kit**

## Connection cable and single plug

<b>Connection cable, assembled</b> (open cable end)	<b>SCK-400-xx-xx</b>
<b>Cable length (m)</b>	
2 m	<b>02</b>
5 m	<b>05</b>
10 m	<b>10</b>
<b>Connecting plug</b>	
M12 cable jack; straight	<b>45</b>
M12 cable jack; 90° angled	<b>55</b>
<b>Single connector</b>	
M12 cable jack; straight	<b>SCK-145</b>
M12 cable jack; 90° angled	<b>SCK-155</b>

## SCT-150 temperature sensor

### Device features

- Withstands pressures up to 630 bar
- Compact design
- Heavy-duty steel housing
- Simple installation
- -25 °C to +100 °C

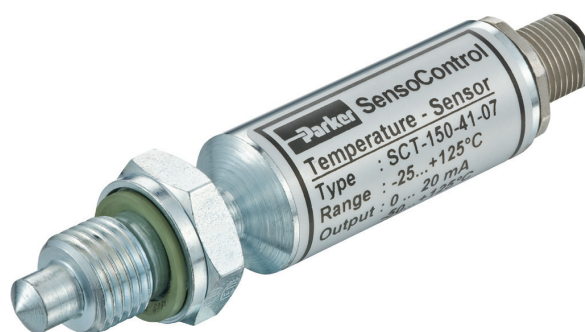

The SCT electronic temperature sensor features a compact design and high pressure resistance.

The SCT is used where temperatures have to be measured under high pressure and a compact housing is necessary.

With its pressure resistance up to 630 bar, the SCT temperature sensor is well suited for hydraulic applications.

It can be used for precise and quick temperature measurements.

The SCT series temperature sensors are compatible with the SCE panel meters. So both the hydraulic pressure and the substance temperature can be measured, checked and evaluated.

### Application examples

- Test benches
- Processing equipment
- Conveying and lifting equipment
- Machine construction
- Pneumatic plant construction
- Hydraulic plant construction

# SCT-150 temperature sensor

Pressure and temperature sensors

## Technical data

Input	
Measuring range	-25...+100 °C
Accuracy	< ± 7 K
Response time	$\tau_{0,9} = 13.5$
Output	
Output <sub>T</sub> (scaling for output!)	0...20 mA = -50...+125 °C
Load	≤ 250 Ω
Process connection	
G1/4A ED or M10x1	
Seal	FKM
Housing	Steel C15K/CF
Operating pressure P <sub>n</sub>	630 bar
Parts in contact with substances	Steel C15K/CF, FKM
Ambient conditions	
Power supply V <sub>+</sub>	+11...+24 VDC
Current consumption	< 30 mA
Ambient temperature range	-20...+70 °C
Fluid temperature range	-25...+125 °C
Storage temperature	-25...+80 °C
Electrical connection	M12x1
Protection degree	IP67

## Pin assignment

Cable	Assignment
1	V <sub>+</sub>
2	T-signal
3	0 V / GND
4	n.c.*

\*n.c. = do not connect

## Order code

Temperature sensor G1/4  
Temperature sensor M10x1

SCT-150-41-07  
SCT-150-14-07

### SCT-150-xx-07

Circular connector M12x1; 4-pole

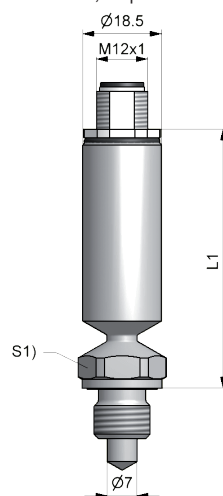

S1) = 19

### SCT-150-41-07

G1/4A ED

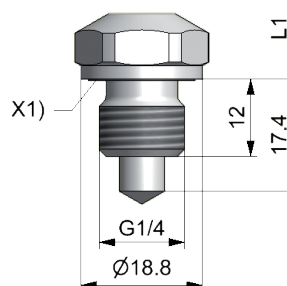

L1) = 61

X1) = ED seal

### SCT-150-14-07

M10x1

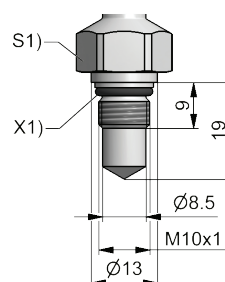

X1) = O-ring

## Volumetric flow rate sensors

### Device features

- Different measurement techniques
  - Quick
  - Not dependent on viscosity
  - Without loss
- Many measurement ranges
- Analogue output signal
- M12 connecting plug
- 24 VDC

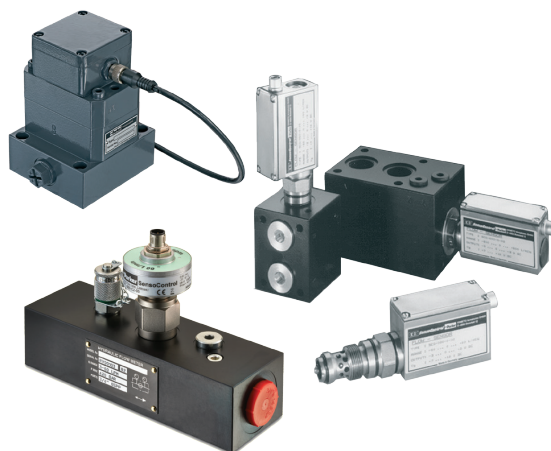

The flow sensors used in **SensoControl®** provide accurate volume flow information in hydraulic systems (e.g. in testing equipment).

The sensors deliver a output signal that is proportional to the volumetric flow rate for further processing to an electronic system. They are compatible with conventional, well-known standards.

- M12 connecting plug
- 24 VDC
- 0/4 to 20 mA

The volumetric flow rate can be easily displayed when using the **SCE-020** panel meter.

In order to meet the many different application requirements, three different measuring principles are available:

- **SCVF** geared counter
- **SCFT** turbine
- **SCQ** spring/piston

The volumetric flow rate sensors are used in control, regulation or monitoring systems where analogue signals are needed to capture the volume flow.

# Volumetric flow rate sensors

## Overview

### SCQ

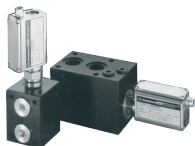

### SCFT



### SCVF



#### Range of use

For quick flow changes  
Measures in both directions

- Response speed  $\leq 2$  ms
- Reverse operation
- Wide viscosity range
- Compact size
- Up to 420 bar

Low loss measuring of volume flow

- Response speed  $\leq 50$  ms
- Many measurement ranges
- Low flow resistance
- Up to 800 l/min
- Up to 420 bar

Measures different substances  
Measures lower volume flows (leakage measurements)

- Very wide measurement range
- Not dependent on viscosity
- Up to 400 bar

#### Applications

- Test rigs
- General machine construction
- Hydraulic plant construction

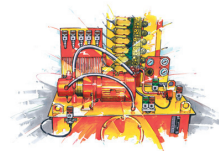

#### Order code

SCQ-xxx-10-07

SCFT-xxx-22-07

SCVF-xxx-10-07

#### Refer to page

35-38

39-42

43-48

# SCQ flow meter

## Device features

- Measurement principle Spring/piston principle
- Response time  $\leq 2$  ms
- Measurement in both directions
- Wide viscosity range
- Compact design
- Withstands pressures up to 420 bar

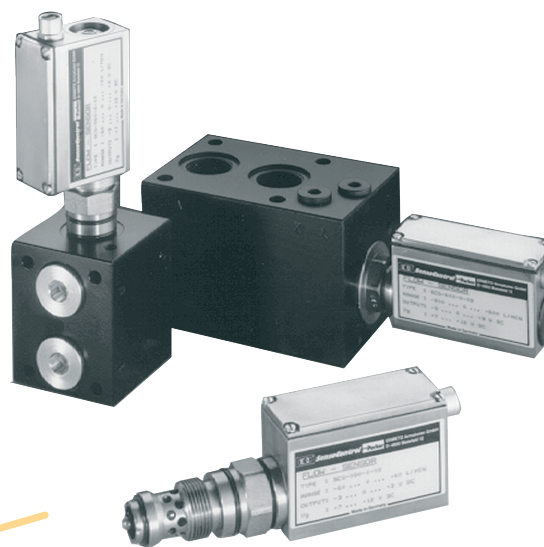

Volumetric flow rate sensors

## Function

The piston (K) is moved due to a flow from A to B or from B to A. In the idle state, the spring (F) and the piston (K) are in equilibrium. The delta (S) is proportional to the flow and is converted to a value through the built-in electronics. Through the change in direction of the piston (B to A), the flow direction can be indicated. (e.g. -45.8 l/min) The reaction time of the piston movement is less than 2 ms.

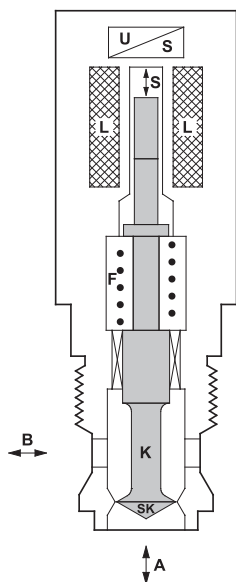

SCQ measurement principle

## Application

When working with high-pressure hydraulics, it is very important to be able to quickly detect the flow rate.

Installation with a connection block permits the combined measurement of p, T and Q. Rapid assembly of the **SCQs** is achieved with an in-line adaptor for tube or hose installation. Use under extreme conditions (such as high load changes or rapid pressure increases) is possible because of the sturdy construction.

The **SCQ** is the perfect solution when recording highly dynamic volume flow changes. Rapid load changes, which can cause damage for example in valves and pumps, can be safely detected. Due to its unique measurement process, the **SCQ** can capture volume flow in both directions.

# SCQ flow meter

## Technical data

SCQ-	150
Measuring range QN	-150...+150 l/min
Qmax	-165...+165 l/min
Substance connection	M42 (NG16)
Weight (g)	1050

Accuracy	
Deviation from characteristic curve	±2 % FS @ 46cSt.
Response time	2 ms
Thermal drift	±0.05 % FS/°C
Repeat accuracy	± 0.5 % FS

Resistance to pressure	
Pressure range	3...420 bar
Operating pressure P <sub>n</sub>	315 bar
Overload pressure P <sub>max</sub>	420 bar
Pressure drop ΔP (bar) @ (FS)	Refer to diagram

Material	
Housing	Steel
Seal	NBR
Parts in contact with substances	Steel, NBR

Ambient conditions	
Operating temperature	+10...+60 °C
Storage temperature	-20...80 °C
Tmax Fluid	+80 °C
Filtration	25 μm
Viscosity range	15...100 cSt.
Protection degree	IP67 DIN EN 60529

Electrical connection	
Plug	M12x1; 4-pole
Supply voltage	+18...+30 VDC
Current consumption	40 mA
Output	0...20 mA = -FS...+FS (10 mA = 0 l/min)
Load	≤ 150 Ω
Signal noise	< 5 mV

EM compatibility	
Disturbance emissions	EN 61000-6-3
Resistance to interference	EN 61000-6-2

Volumetric flow rate sensors

## Pin assignment

M12x1; 4-pole

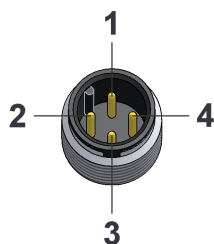

PIN	Assignment
1	V <sub>+</sub>
2	Q signal
3	0 V / GND
4	-

# SCQ flow meter

Screw plug hole and pressure-drop curve **SCQ-150**

30 Nm torque

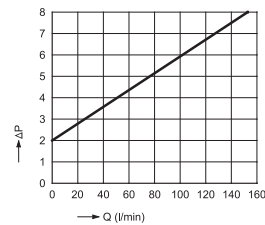
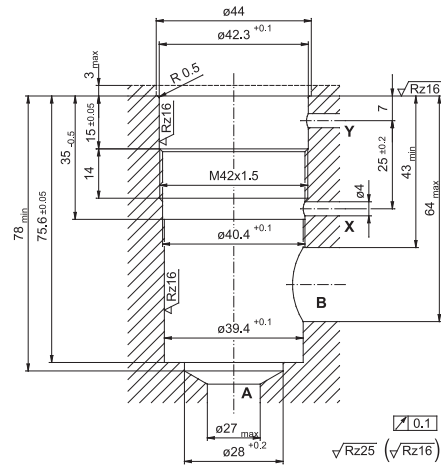
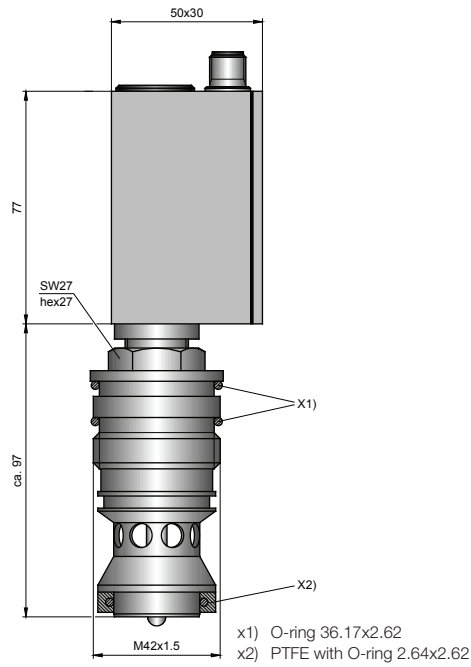

Volumetric flow rate sensors

# SCQ flow meter

## SCAQ-GI-R1/2

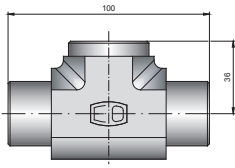

## SCAQ-150

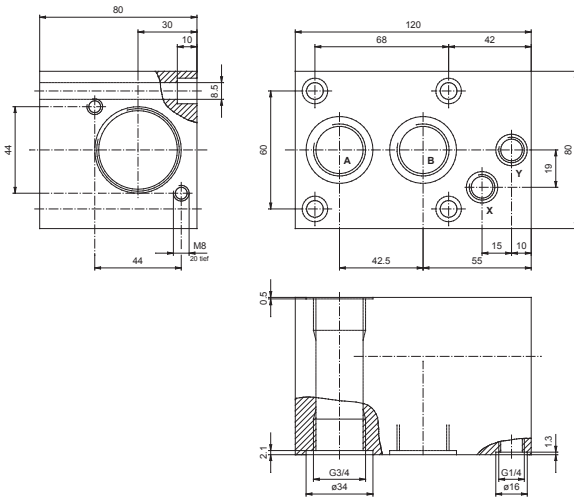

Volumetric flow rate sensors

## Order code

### SCQ-150 (-150 to +150 l/min)

M12x1, 4-pole; connecting plug; IP67  
0 to 20 mA; -150...+150 l/min

**SCQ-150-10-07**

### Accessories SCQ-150

Connector block  
G3/4 BSPP inner (A-B) and M42 inner  
With screw plug:  
M42 outer and  
G3/4 BSPP outer (A-B)

**SCAQ-150**

### Spare parts

Spacer ring for SCQ-060  
Seal kit for SCQ-060  
Seal kit for SCQ-150

**SC-910**

**SC-911**

**SC-912**

## Connection cable and single plug

### Connection cable, assembled

(open cable end)

**SCK-400-xx-xx**

#### Cable length (m)

2 m	<b>02</b>
5 m	<b>05</b>
10 m	<b>10</b>

#### Connecting plug

M12 cable jack; straight	<b>45</b>
M12 cable jack; 90° angled	<b>55</b>

### Single connector

M12 cable jack; straight  
M12 cable jack; 90° angled

**SCK-145**

**SCK-155**

# SCFT measurement turbine

## Device features

- Measurement principle: Turbine
- Response speed  $\leq 50$  ms
- Measurement range from 1 to 800 l/min
- Low flow resistance
- Suitable for reverse operation
- Built-in pressure and temperature ports



Volumetric flow rate sensors

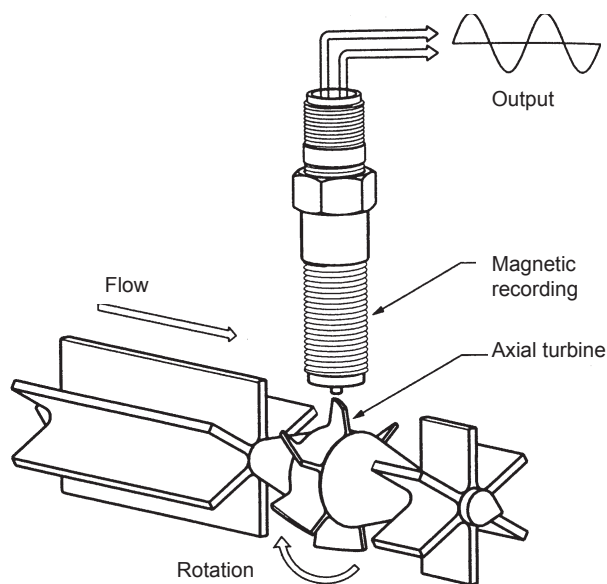

## Function

The turbine wheel is driven by the oil flow. The generated frequencies are processed through the digital electronics and influences from the disturbing flow effects are compensated for. Because of the low flow resistance  $Q_R$ , the hydraulic circuit operates with very low losses.

Reverse operation is also possible because of the special vane (winged) design - so the turbine can be operated in both directions.

The turbine is fitted with an EMA-3 screw coupling for measuring pressure. Oil temperature can be measured directly in the oil flow of the turbine by connecting the temperature sensor (SCT-150). This provides all important measurements at the installation location.

## Application

The SCFT is the ideal solution if the volumetric flow rate needs to be recorded loss-free across a wide flow range (up to 800 l/min.).

# SCFT measurement turbine

## Technical data

SCFT-	015	060	150	300	600	800
Flow measuring range Q <sub>n</sub> (l/min)	1...15	3...60	5...150	8...300	15...600	20...800
Accuracy (± %) FS/IR @ 21cSt.	± 1 % FS	± 1 % IR	± 1 % IR	± 1 % IR	± 1 % IR	± 1 % IR
Operating pressure P <sub>n</sub> (bar)	350	350	350	350	290	400
Ports (A - B)	G1/2 BSPP	G3/4 BSPP	G3/4 BSPP	G1 BSPP	G1 1/4 BSPP	G1 7/8 UNF
Pressure drop ΔP (bar) @ (FS)	1.5	1.5	1.5	4	4	5
Weight (g)	700	1600	1600	1700	2700	5000

FS = Full Scale  
IR = Indicated Reading

Volumetric flow rate sensors

Accuracy	
Response time	50 ms
Thermal drift	±0.05 % FS/°C
Repeat accuracy	± 0.5 % FS
Resistance to pressure	
Q <sub>max</sub> (l/min)	Q <sub>N</sub> x 1.1
Overload pressure P <sub>max</sub>	P <sub>N</sub> x 1.2
Material	
Housing	Aluminium
Seal	FKM
Parts in contact with sub- stances	Aluminium, steel, FKM
Ambient conditions	
Ambient temperature	-10...+50 °C
Storage temperature	-20...+80 °C
T <sub>max</sub> Fluid	-20...+80 °C
Filtration	25 µm (10 µm for SCFT-015)
Viscosity range	15...100 cSt.
Protection class	IP66 EN60529

Ports	
Temperature measurement (SCT-150-14-07)	M10x1 OR
Pressure connection	EMA3
Pressure (VSTI)	G1/4 BSPP
Electrical connection	
Plug	M12x1; 5-pole
Power supply V <sub>+</sub>	18...30 V
Output signal	4...20 mA ± 0...FS l/min
Complete output current range	0...21 mA
Current consumption	< 30 mA
Protection degree	IP66 EN60529

## Pin assignment

M12x1; 5-pole

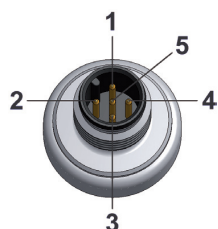

PIN	Assignment
1	V <sub>+</sub>
2	n.c.
3	Q signal
4	n.c.*
5	0 V / GND

\*n.c. = do not connect



# SCFT measurement turbine

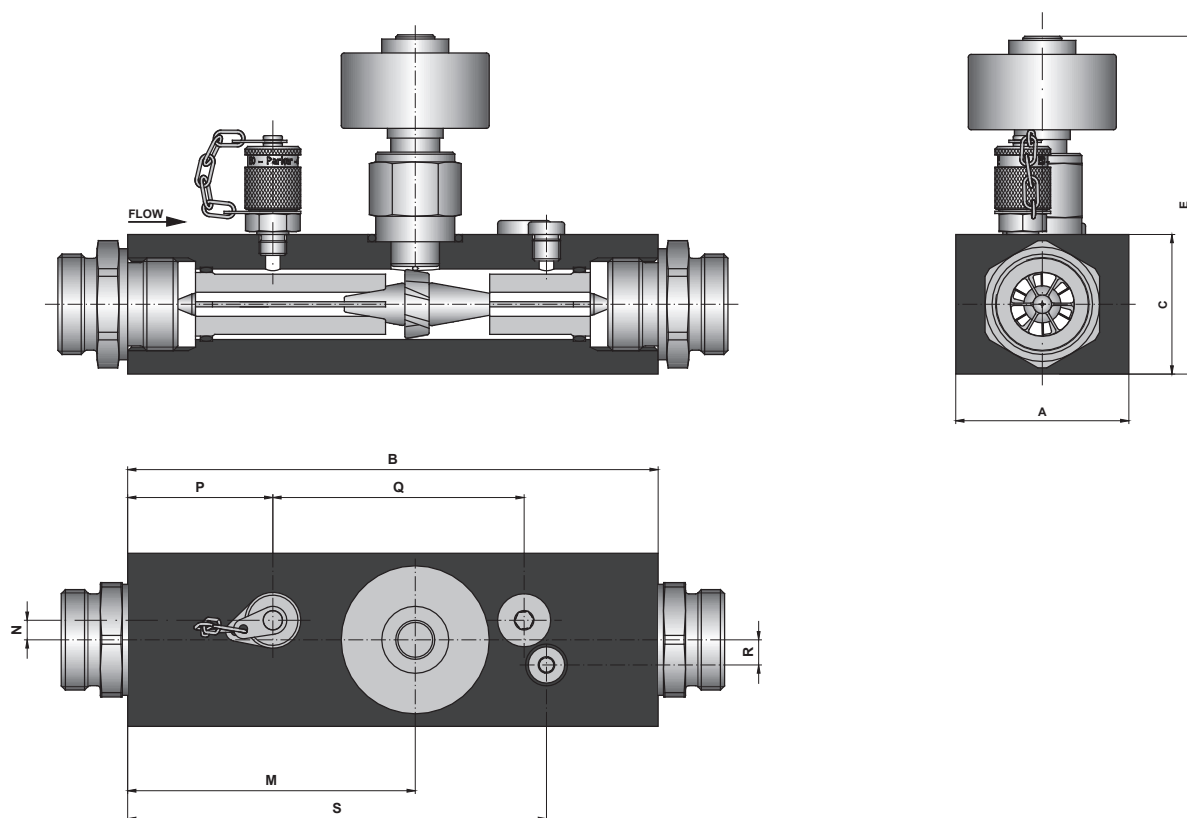

Volumetric flow rate sensors

#	SCFT-015	SCFT-060	SCFT-150	SCFT-300	SCFT-600	SCFT-800
A	37	62	62	62	62	100
B	136	190	190	190	212	212
C	37	50	50	50	75	75
E	115	130	130	134	149	152
M	70	103	103	103	127	126
N	0	5	5	7	9	10
P	25	50	50	52	62	60
Q	N/A	92	92	90	106	104
R	0	5	5	9	11	10
S	115	157	157	150	168	181



# SCFT measurement turbine

## Order code

### SCFT

M12x1, 5-pole; connecting plug; IP66

4...20 mA (3-wire)

1...15 l/min

**SCFT-015-22-07**

3...60 l/min

**SCFT-060-22-07**

5...150 l/min

**SCFT-150-22-07**

8...300 l/min

**SCFT-300-22-07**

15...600 l/min

**SCFT-600-22-07**

20...800 l/min

**SCFT-800-22-07**

## Connection cable and single plug

### Connection cable, assembled

**SCK-400-xx-xx**

(open cable end)

#### Cable length (m)

2 m

**02**

5 m

**05**

10 m

**10**

#### Connecting plug

M12 cable jack; straight

**45**

M12 cable jack; 90° angled

**55**

### Single connector

M12 cable jack; straight

**SCK-145**

M12 cable jack; 90° angled

**SCK-155**

## SCVF volume counter

### Device features

- Measurement principle: Volume/geared counter
- Eight measurement ranges from 0.01 - 2 to 1 - 300 l/min
- Accuracy  $\pm 0.5\%$  FS
- Withstands pressures up to 400 bar
- High viscosity range
- Low noise
- Exact flow rate measurement over a wide viscosity range
- Versatile usage for different substances

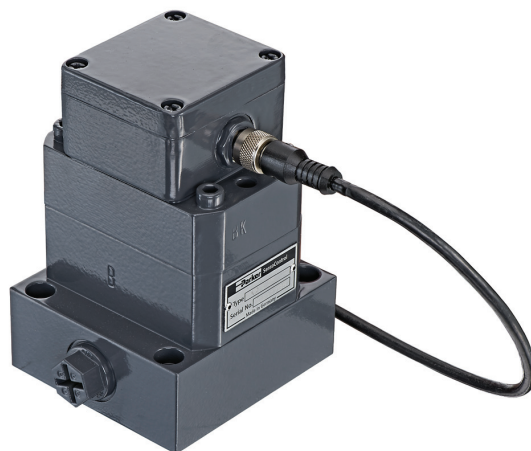

### Gear counter for highly accurate flow rate measurements in hydraulic systems

#### Function

The SCVF geared counter functions as a volume flow meter. A very precisely crafted pair of geared wheels is driven by the fluid flow.

The SCVF works over a wide viscosity range. Different seals permit usage in many different applications.

#### Applications

Due to the wide viscosity range, any liquid can be measured that can be pumped and has a certain degree of lubricating capability.

- Brake fluid (EPDM seal)
- Skydrol
- Mineral oils
- Hydraulic oil and
- Grease

The SCVF is the ideal solution when carrying out precise flow rate measurements over a wide viscosity range.

# SCVF volume counter

## Technical data

SCVF-	002	004	015	040	060	080	150	300
Flow measuring range (l/min)	0.01...2.0	0.02...4.0	0.2...15	0.4...40	0.4...60	0.4...80	0.6...150	1.0...300
Pressure range P <sub>N</sub> (bar)	400	315	400	400	400	400	315	315
Overload pressure P <sub>O</sub> (bar)	480	400	480	480	480	480	350	350
Connection	G3/8 BSPP	G3/8 BSPP	G3/8 BSPP	G1/2 BSPP	G1/2 BSPP	G1/2 BSPP	G1 BSPP	G1 BSPP
Sound level dB (A)	< 60	< 60	< 60	< 70	< 70	< 70	< 70	< 72
Resolution (pulses / litre)	40,000	25,000	4082	965	965	965	333.33	191

Volumetric flow rate sensors

Accuracy	
Deviation from characteristic curve	± 0.3 % FS ≥ 20 cSt. ± 0.5 % FS ≥ 20 cSt.
Response time	< 10 ms
Repeat accuracy	0.01 % FS
Substance *)	Hydraulic oil (25 micron filter)
Material	
	Material 1.7139 Contains no non-ferrous metal or silicone
Housing	Steel
Seal	FKM EPDM on request
Ambient conditions	
Ambient temperature	0...+55 °C
Storage temperature	-25...+85 °C
Fluid temperature	-30...120 °C
Viscosity range	Refer to diagram p. 48
Protection degree	IP65 DIN EN 60529

Electrical connection	
Plug	M12x1; 4-pole
Power supply V <sub>+</sub>	+18...+30 VDC
Current consumption	< 28 mA
Output signal	0...20 mA ± 0...FS l/min
Load	≤ 150 Ω
EM compatibility	
Disturbance emissions	EN 61000-6-3
Resistance to interference	EN 61000-6-2

FS = Full scale value

\*) When using other substances, please state the viscosity range and the type of seals. (Attach the data sheet of the substance if possible)

## Pin assignment

M12x1; 4-pole

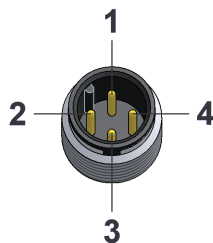

PIN	Assignment
1	V <sub>+</sub>
2	Q-signal
3	0 V / GND
4	-



# SCVF volume counter

## Technical data

SCVF-002  $\Delta p$  - Viscosity

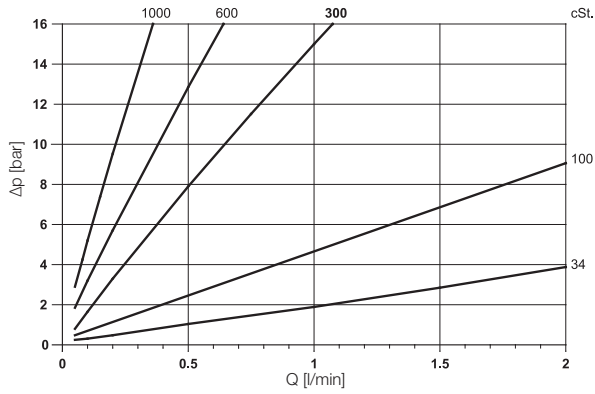

SCVF-004  $\Delta p$  - Viscosity

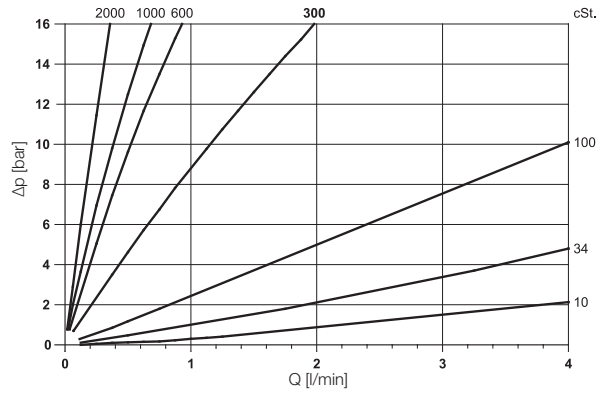

SCVF-015  $\Delta p$  - Viscosity

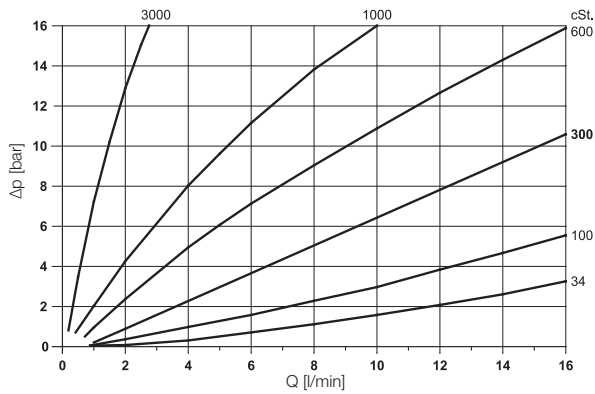

SCVF-040/060/080  $\Delta p$  - Viscosity

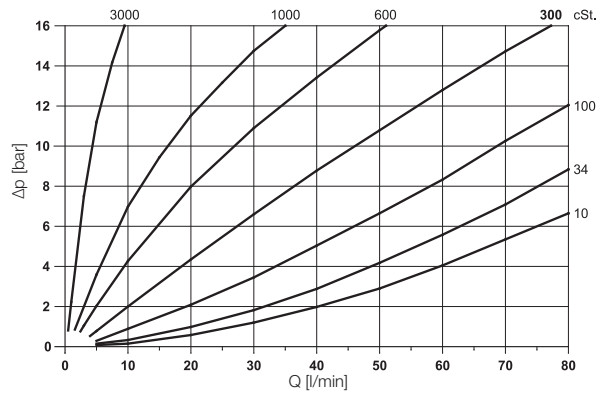

SCVF-150  $\Delta p$  - Viscosity

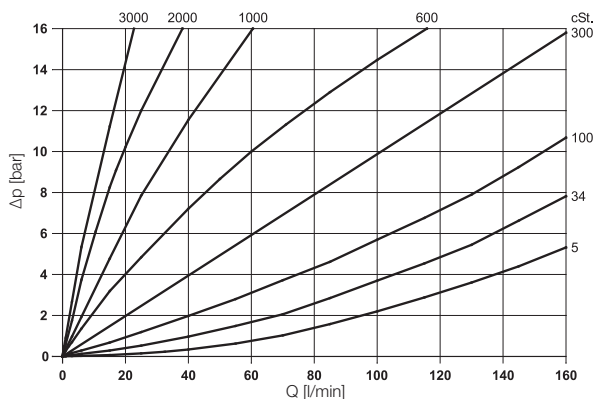

SCVF-300  $\Delta p$  - Viscosity

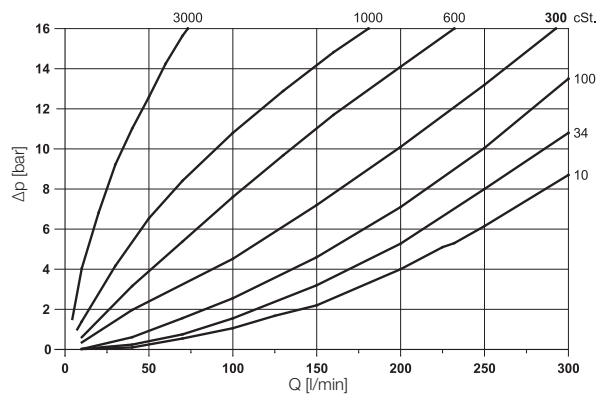

$\Delta p$  = pressure loss



# SCVF volume counter

Volumetric flow rate sensors

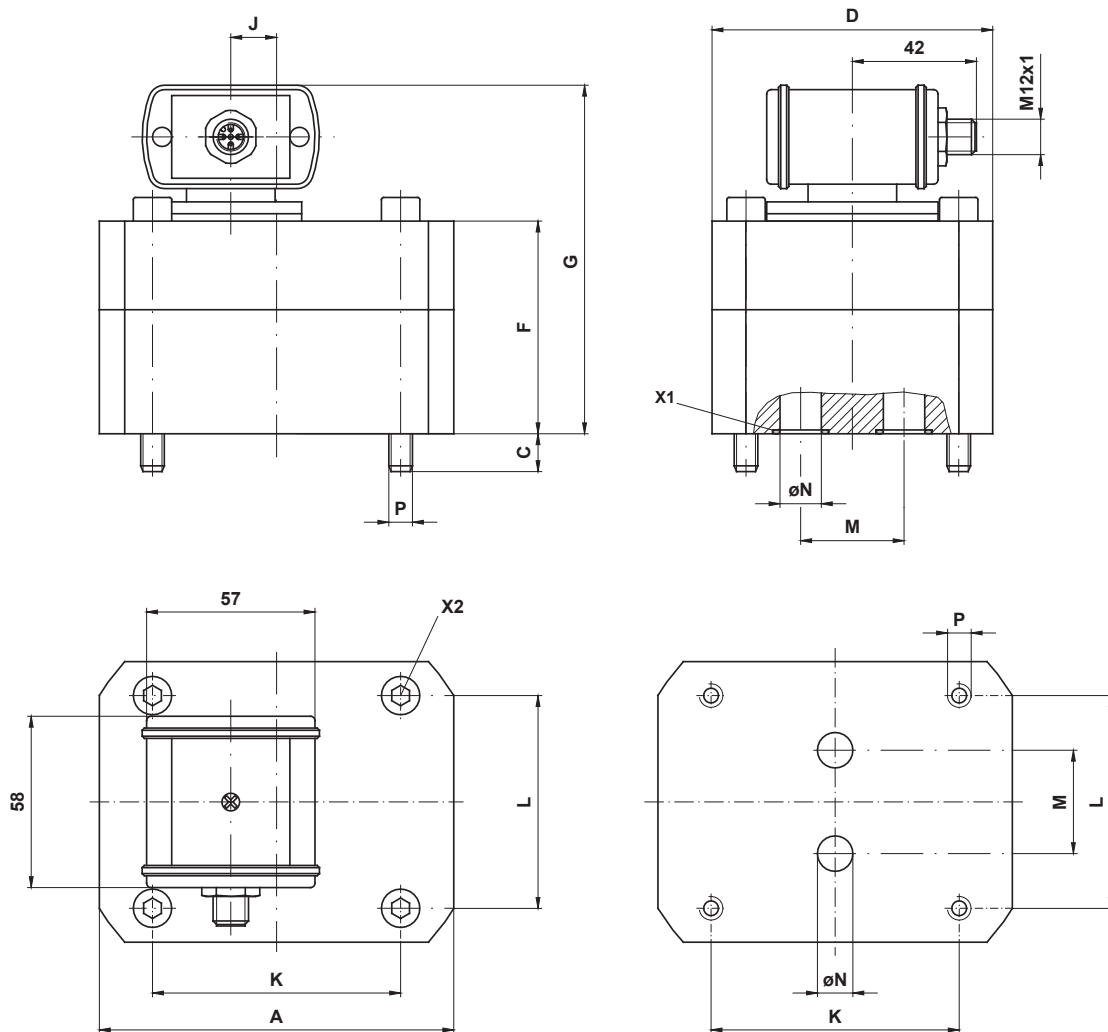

Type	Weight [kg]	Torque [Nm]	A	C	D	F	G	J	K	L	M	ØN	P
SCVF-002	1.8	14	85	10	60	50	87	-	70	40	20	6.5	M6
SCVF-004	2	14	85	9	60	56		-	70	40	20	6.5	M6
SCVF-015	2	14	85	13	60	57	94	-	70	40	20	9	M6
SCVF-040 SCVF-060 SCVF-080	5.2	35	120	13	95	72	109	10.5	84	72	35	16	M8
SCVF-150	9	120	170	18	120	89	140	46.5	46	95	50	25	M12
SCVF-300	13	120	170	22	120	105	142	40	46	95	50	25	M12

All measurements in mm



# SCVF volume counter

## Dimensioned drawings connection plate

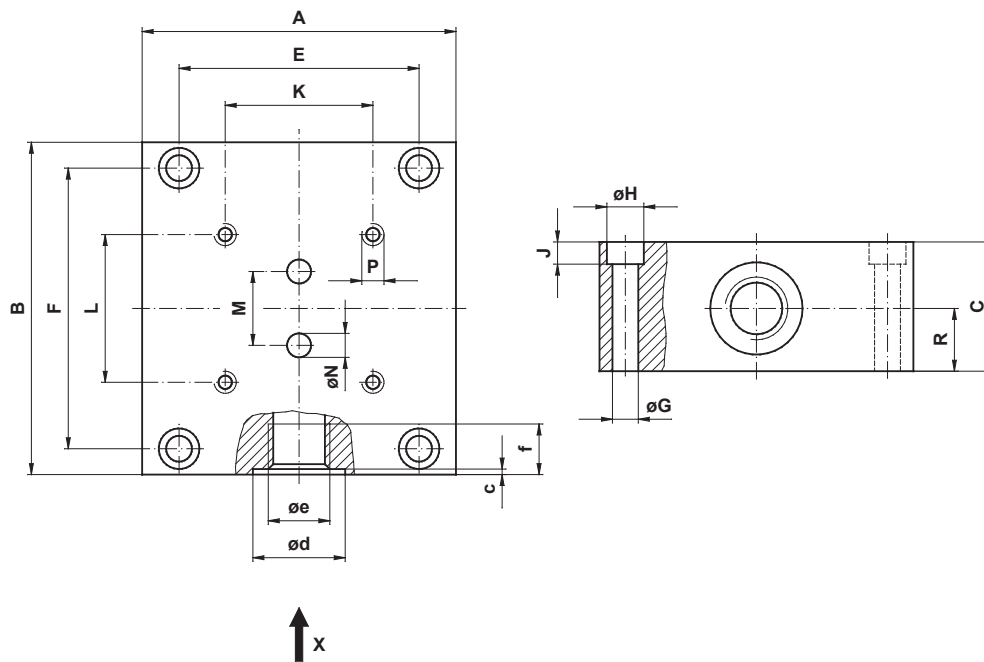

Volumetric flow rate sensors

Type	kg	A	B	C	E	F	øG	øH	J	K	L	M	øN	P	R	c	ød	øe BSPP	f
SCVF-002 SCVF-004 SCVF-015	1.8	85	90	35	65	76	7	11	7	70	40	20	6.5	M6/t = 14	17	0.7	25	G3/8	13
SCVF-040 SCVF-060 SCVF-080	2.9	100	120	37	80	106	7	11	7	84	72	35	12	M8/t = 18	17.5	0.7	29	G 1/2	15
SCVF-150 SCVF-300	14	160	165	80	140	145	9	15	9	46	95	50	25	M12/t = 24	28	1	42	G1	19

All measurements in mm



# SCVF volume counter

## Order code

### SCVF

M12x1, 4-pole; connecting plug; IP65; incl. connection plate

0...20 mA

0.01...2 l/min

**SCVF-002-10-07**

0.02...4 l/min

**SCVF-004-10-07**

0.2...15 l/min

**SCVF-015-10-07**

0.4...40 l/min

**SCVF-040-10-07**

0.4...60 l/min

**SCVF-060-10-07**

0.4...80 l/min

**SCVF-080-10-07**

0.6...150 l/min

**SCVF-150-10-07**

1...300 l/min

**SCVF-300-10-07**

Volumetric flow rate sensors

## Connection cable and single plug

### Connection cable, assembled

**SCK-400-xx-xx**

(open cable end)

#### Cable length (m)

2 m

**02**

5 m

**05**

10 m

**10**

#### Connecting plug

M12 cable jack; straight

**45**

M12 cable jack; 90° angled

**55**

### Single connector

M12 cable jack; straight

**SCK-145**

M12 cable jack; 90° angled

**SCK-155**

## SCE-020 digital display unit

### Device features

- Easily readable digital display:
  - Large
  - Bright
- Programmable
- Unit of measure can be selected
- Adjustable display range
- Input:
 

Current	0/4 to 20 mA
Voltage	0 to 10 V
- Switching output
- Loop-through function:
  - Analogue output
  - Serial interface
- Standard housing 96 x 48 mm



Diverse connections, a flexible display and many outputs are the features of the digital display SCE.

The SCE-020 converts standard analogue signals (in the range 0 to 10 V up to 0/4 to 20 mA) into clearly readable measurement values or units.

The **SCE-020** can be used to easily display every desired sensor. (pressure, temperature, torque, length, etc.)

### Functions

The display can be read from a long distance. The measurement range and the decimal point can be adjusted to fit user requirements so that different measurement values can be displayed.

The accompanying units are mounted on a separate illumination area.

The power supply varies from 11 to 30 VDC.

An adjustable limit value can be monitored using the floating switching output.

### Loop-through function

The analogue output or the RS232 serial interface can forward the signal to the appropriate peripheral.

The SCE-020 display unit can be used when different measurement values need to be displayed in a simple and flexible manner.

# SCE-020 digital display unit

## Technical data

	<b>SCE-020-2</b>
Input	0...20 mA, 4...20 mA or 0...10 V
Input resistance	0...20 mA = 150 Ω, 4...20 mA = 150 Ω, 0...10 V = 67 KΩ
Analogue output	0...20 mA, 4...20 mA
Analogue output load	≤ 500 Ω
Interface	RS-232C
Limit value	Floating CO contact 250 V/5 A max.

<b>Input</b>	
Measurement error	± 0.2 % of the display °± 1 digit
Measurement rate	5 ms Threshold query every 5 ms
Measuring range	Freely selectable (programmable)
<b>Display</b>	
Display	4-digit 7-segment LED
Display range	-999 to 9999
Digit height	13 mm
Decimal point	Freely programmable
Dimension display	Selectable, by attaching a dimensioning label to the appropriate illumination area
<b>Ambient conditions</b>	
Operating temperature range	0...+60 °C
Storage temperature range	-25...+80 °C
Relative humidity	< 80 %
Protection degree	IP44

<b>Power supply</b>	
Auxiliary Power	11...30 VDC
Current consumption	Approx. 100 mA
<b>Housing</b>	
Material	PC ABS black Self-extinguishing according to UL94V0, For table and console installation
Front dimensions	96 x 48 mm
Installation depth	131 mm
Connection	12 -pole terminal block with wire protection, max. 1.5 mm <sup>2</sup>
Mounting position	As required
Weight	Approx. 200 g

## Pin assignment

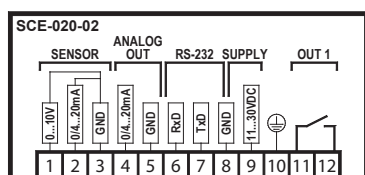

# SCE-020 digital display unit

## Connection examples (0/4 to 20 mA)

### SCE-020-02

Pressure sensor SCP

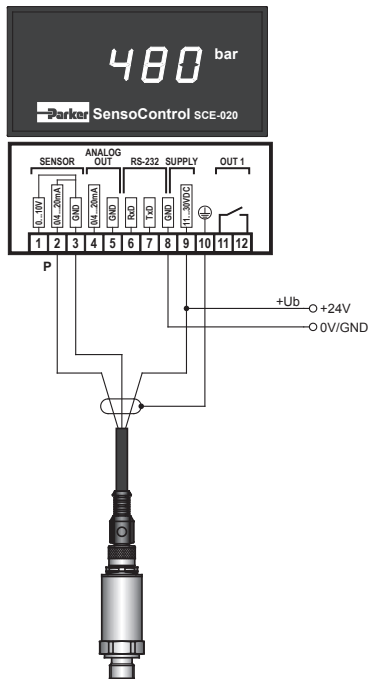

### SCE-020-02

Temperature sensor SCT

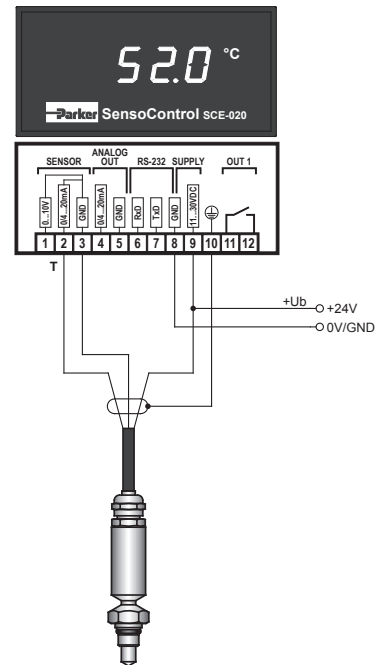

### SCE-020-02

Flow sensor

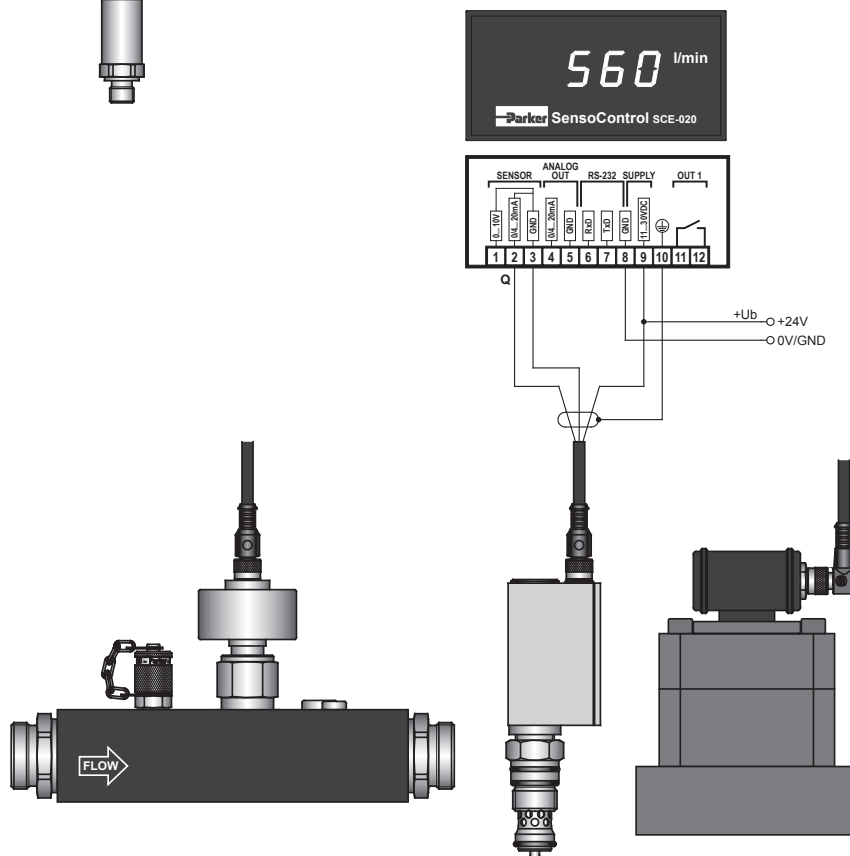

Digital displays

# SCE-020 digital display unit

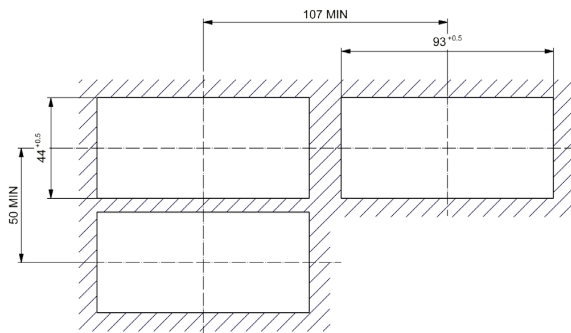

## Order code

**SCE-020** Input 0/4 to 20 mA/0 to 10 V

**SCE-020-02**

+ 1 switching output  
+ RS232C serial interface

### Accessories:

Data cable SCE – PC

**SCK-300-02-31**

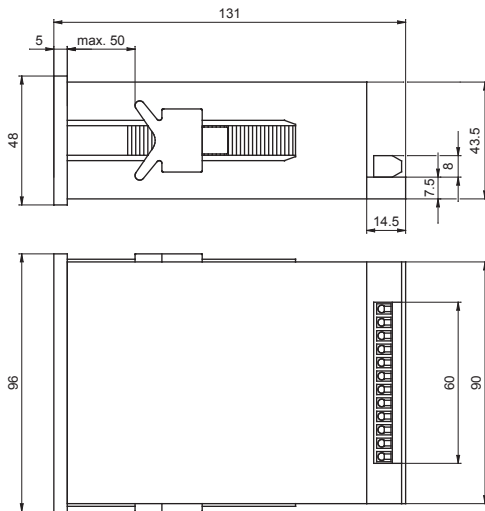

Digital displays

# The Controller Family

## Device features

- Large display
- Freely adjustable
- Rugged metal construction
- Compact size
- Long-term stability
- Dependable
- Immune to interference



This controller is used in control, regulation or monitoring systems where switching signals or analogue signals are used or a display is required.

The controller can replace the following:

- Mechanical switches
- Mechanical displays  
(pressure gauges, thermometers, inspection glass)
- Sensors

All the above mentioned functions can be combined in one device.

All control devices have a compact and pivoting metal housing so that they can be mounted optimally under adverse installation conditions. The large display can always be perfectly positioned so that it is easy to read even at longer distances.

Both of the switching outputs can be set individually either as NO or NC. They also both have hysteresis and the window functions. Therefore the on and off switching values as well as delay times (attenuation) for each of the switching points can be chosen freely.





Thanks to these easy switching functions, intelligent adjustments can be set which are normally not possible using a mechanical switch. Therefore, many switches can be replaced with one controller.



The controllers offer good practical characteristics combined with diverse mounting and setting options.

Because of its compact design, long lifespan and high functionality, this controller is ideal for the permanent series use in hydraulic and pneumatic applications.

# The Controller Family

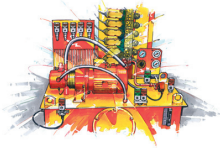
## Overview

	SCPSDi	SCPSD	SCTSD	SCTSD-L
				
<b>Range of use</b>	Pressure display and monitoring		Temperature display and monitoring	Temperature display and level monitoring
	<ul style="list-style-type: none"> <li>Compact size</li> <li>Resistant to pressure peaks</li> <li>Resistant to shock and vibration</li> <li>IO link</li> </ul>	<ul style="list-style-type: none"> <li>Compact size</li> <li>Resistant to pressure peaks</li> <li>Resistant to shock and vibration</li> </ul>	<ul style="list-style-type: none"> <li>Temperature display</li> <li>Modular design</li> <li>Suitable for control panel and tank construction</li> <li>High pressure version</li> </ul>	<ul style="list-style-type: none"> <li>Temperature display</li> <li>Fixed level contacts</li> </ul>
<b>Applications</b>	<ul style="list-style-type: none"> <li>Test benches</li> <li>Processing equipment</li> <li>Conveying and lifting equipment</li> <li>General machine construction</li> <li>Pneumatic plant construction</li> <li>Hydraulic plant construction</li> </ul>			
<b>Order code</b>	SCPSDi-xxx-x4-x7	SCPSD-xxx-x4-xx	SCTSD-150-xx-xx	SCTSD-L-xxxxx-xxxxx
<b>Refer to page</b>	55-60	61-66	67-78	79-82

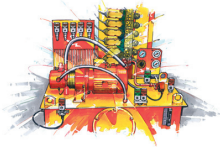
	SCLSD	SCLTSD	SCOTC	
				
<b>Range of use</b>	Level indication and monitoring	Level/temperature display and monitoring		
	<ul style="list-style-type: none"> <li>Level display</li> <li>Practical monitoring with window function</li> <li>Continuous level measurement</li> </ul>	<ul style="list-style-type: none"> <li>Level display</li> <li>Temperature display</li> <li>Continuous level measurement</li> <li>One bore hole</li> </ul>	<ul style="list-style-type: none"> <li>Level display</li> <li>Temperature display</li> <li>Continuous level measurement</li> <li>One bore hole</li> <li>Connection to the filling coupling</li> <li>Connection to the air filter</li> </ul>	
<b>Applications</b>	<ul style="list-style-type: none"> <li>Test benches</li> <li>Processing equipment</li> <li>Conveying and lifting equipment</li> <li>General machine construction</li> <li>Pneumatic plant construction</li> <li>Hydraulic plant construction</li> </ul>			
<b>Order code</b>	SCLSD-xxx-x0-07	SCLTSD-xxx-x0-07	SCOTC-xxx-x0-07	
<b>Refer to page</b>	83-88	89-94	95-100	

# SCPSDi PressureController

## Device features

- IO LINK
- VDMA menu
- ECO mode
- > 360° pivot function
- 180° reversible display
- Analogue output V/mA
- Operator safety improved with LOCK
- Compact size
- Rugged
- MPa, bar, PSI
- Metal housing
- Installation width 35 mm
- Installation height 78 mm



The SCPSDi is an electronic pressure switch with:

- Pressure display
- Two programmable switching outputs
- Optional analogue output signal
- IO-Link interface
- VDMA menu navigation

The key features of the SCPSDi are the innovative design and the resulting installation options combined with the diverse connection possibilities.

These unique functions make the SCPSDi ideal for permanent series use in industrial applications.

### Innovative construction design

The external-thread pressure port is stop-free and can be turned independently of the housing. So you can install the pressure connection without turning the housing. The small size means that it can easily be installed in cramped quarters. After the installation, the housing can be fully rotated over 360° with no stop. It also locks into position while under pressure.

For the internal-thread pressure port, all components that come into contact with the pressurized substance are made from stainless steel. It does not have any seals so it can be used with a wide range of substances including corrosive and aggressive media.

The display is readable from large distances and can be rotated through 180° for overhead installation. A horizontally-mounted display is optionally available.

### Reliable / safe / sturdy

The pressure is recorded with a long-term stable and maintenance-free measuring cell. A functional error is signalled and can be processed further according to DESI-NA. The metal housing is void of moving seals and is resistant to moisture, shock and vibrations.

### Easy to use

The terminology and symbols used, as well as the menu structure used for setting parameters can be easily browsed using the buttons in accordance with the VDMA standard journal (VDMA 24574-1) or automatically using IO Link.

### Universal

Each switching output can be adjusted individually:

- NO/NC contact
- On/off switching pressures
- Delay times
- Hysteresis / window function

The optional analogue output is switchable between 0/4 to 20 mA and 0 to 10 V. An unintentional parameter change is prevented with use of the LOCK function (button lock).

Numerous versions are available for the many different applications.

- Diverse pressures ranges up to 600 bar
- Diverse inner and outer threads
- With or without analogue output

# SCPSDi PressureController

## Device features

### Display

- Active-lit LED display
- Pressure display
- Units are displayed
- Bar / PSI / MPa
- Switch status is shown
- 180° rotation for top mount
- ECO mode\*

### Design

- No moveable seals
- Few housing elements
- No mixing of materials
- Ergonomic
- Minimal surface area for dirt
- Compact size
- Plug in the front
- Compact installation dimensions
- Sloped display

### Measuring component

- Hermetically sealed and welded stainless steel membrane
- Zero-point stability
- Long-term stability
- No wear and tear
- Excellent pressure resistance
- Up to a nominal pressure of 600 bar

### Innovative construction of external threads

- The external-thread pressure port is stop-free and can be turned independently of the housing. So you can install the pressure connection without turning the housing.
- The housing can be set in any direction for optimal cable routing and locks under pressure.
- Self-contained housing
- No force is exerted on the measuring component during installation
- Stainless steel
- BSP/UNF/NPT
- NBR sealing

### Housing

- Metal housing
- No movable elements, therefore wear-free
- Not sensitive to external environment
- Waterproof IP67
- Rugged

### Adjustments and settings

- VDMA menu navigation
- Two large buttons
- LOCK function\*\*

### M12

- Threaded metal connection
- The plug cannot be over-rotated or broken off
- VDMA-compliant assignment of pins
- IO link
- DESINA
- 2 switching outputs
- Switchable analogue output
  - 0...20 mA
  - 4...20 mA
  - 0...10 V
- Excellent interference immunity

### Inner thread

- All components that come into contact with the substance being measured are made from stainless steel
- No internal sealing components
- Wide range of compatible substances
- Resistant against corrosive and aggressive substances

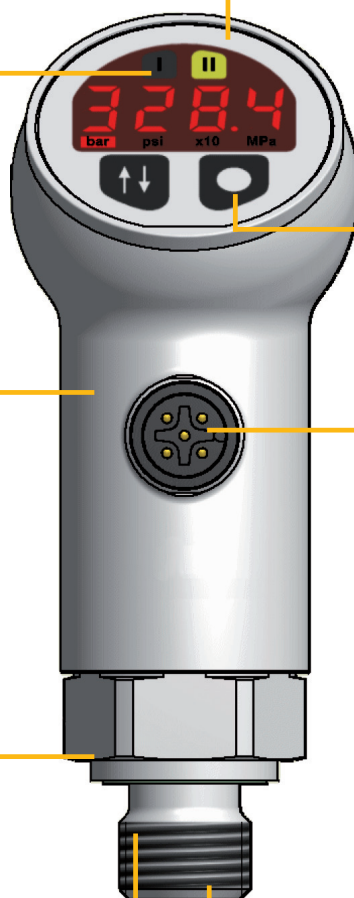

\* ECO mode (activated via menu): pressure switch is run with minimum power in this mode  
 \*\* LOCK function (button lock): Prevents accidental changing of the pressure switch parameters

# SCPSDi PressureController

## Technical data

SCPSDi-	010	016	025	060	100	250	400	600
Pressure range $P_n$ relative (bar) Adjusting range RSP...SP (Lowest reset switch point ... highest switch point)	-1...10	-1...16	-1...25	0...60	0...100	0...250	0...400	0...600
Overload pressure * $P_{max}$ relative (bar)	2 x $P_n$							
Burst pressure ** $P_{burst}$ relative (bar)	3 x $P_n$							
Display resolution Increment size (bar)	0.01	0.01	0.01	0.1	0.1	1	1	1
Smallest adjustable difference between SP and RSP (SP-RSP)	0.01	0.01	0.01	0.1	0.1	1	1	1

\* DIN EN 60770-1

\*\* DIN 16086

Input values	
Switching cycles	≥ 100 million
Scanning rate	≤ 10 ms
Process connection Inner/outer thread	G1/4 BSPP, 7/16 UNF, NPT
Tightening torque	35 Nm
Parts in contact with substances	Inner thread Stainless steel 1.4301; 1.4404  Outer thread Stainless steel 1.4301; 1.4404; 1.0718 CF; NBR
Temperature range of substance	-20...+105 °C
MTTFd	> 100 years
Output values	
Accuracy*	± 0.5% FS typ.; +/- 1% FS max.
Temperature drift	± 0.03% FS/K
Long-term stability	± 0.2% FS/a
Repeat accuracy	± 0.25% FS
Switch point accuracy	± 0.5% FS typ.; +/- 1% FS max.
Display accuracy	± 0.5% FS +/- 1 digit typ. ± 1% FS +/- 1 digit max.
Max. display value	110% $P_n$
Analogue output	+/- 0.5% FS typ.; +/- 1% FS max.

\* Including non-linearity, hysteresis, zero-point and full-scale deviations (corresponds to measurement deviations according to IEC 61298-2)

Response speed	
Switching output	≤ 10 ms
Analogue output	≤ 10 ms

Electrical connection	
Supply voltage $V_+$	Nominal 24 VDC; 12...30 VDC
Electrical connection	M12x1; 4-pole according to DIN EN 61076-2-101
Short circuit protection	Yes
Reverse polarity protection	Yes
Overload protection	Yes
Current consumption	< 50 mA; in ECO mode < 40 mA
Switch-on current	< 100 mA
Outputs	
Switching output 1	High-side/low-side switch (PNP/NPN)  Switching current: max. 200 mA  Short-circuit current: 400 mA (short-term), Short-circuit resistance  Switching voltage: Supply voltage – 1.5 VDC
Switching output 2	High-side (PNP)* Optional  Switching current: max. 500 mA  Short-circuit current: 800 mA (momentary), short-circuit-proof  Switching voltage: $V_+$ – 1.5 VDC
IO Link	Specification V1.0 PNO Order No. 2.802
Analogue output	4...20 mA, 0...20 mA, 0...10 V

\*see ECN15003

# SCPSDi PressureController

## Technical data

Housing	
Rotating	> 360°
Readability of the display	viewing angle can be rotated 180° Configurable (programming)
Display	4-digit 7-segment LED with additional symbols for units and switching status display; Digit height: ~6 mm, Height of units: ~2 mm
Material	Die-cast nickel-plated zinc
Protection degree	IP67
Weight	148 g
Ambient conditions	
Ambient temperature range	-25...+85 °C
Storage temperature range	-40...+85 °C
Vibration resistance	20 g; 10...500 Hz; IEC60068-2-6
Shock resistance	50 g; 11 ms; IEC60068-2-29
EM compatibility	
Disturbance emissions	EN 61000-6-3
Interference immunity	EN 61000-6-2
General	
MTTFd	> 100 years
RoHS-compliant	Yes

## Pin assignment

M12x1; 4-pole

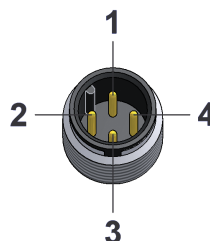

PIN	Assignment
1	V <sub>+</sub>
2	S2 out / analogue
3	0 V / GND
4	S1 out / IO Link

# SCPSDi PressureController

SCPSDi-xxx-xx-17

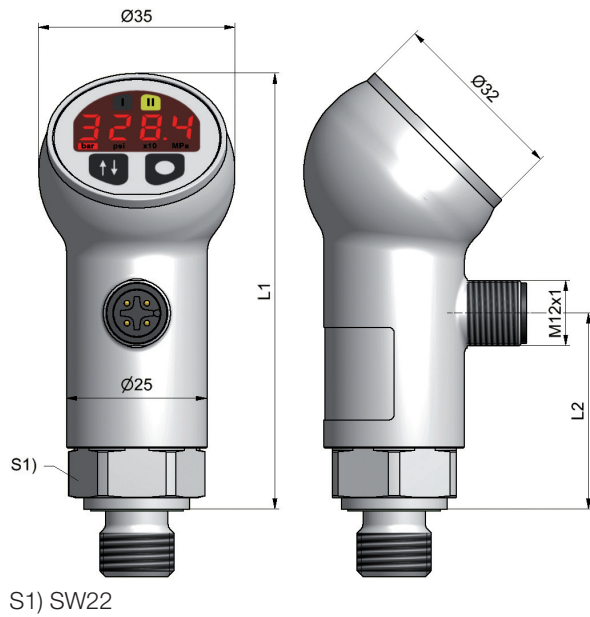

SCPSDi-xxx-xx-27

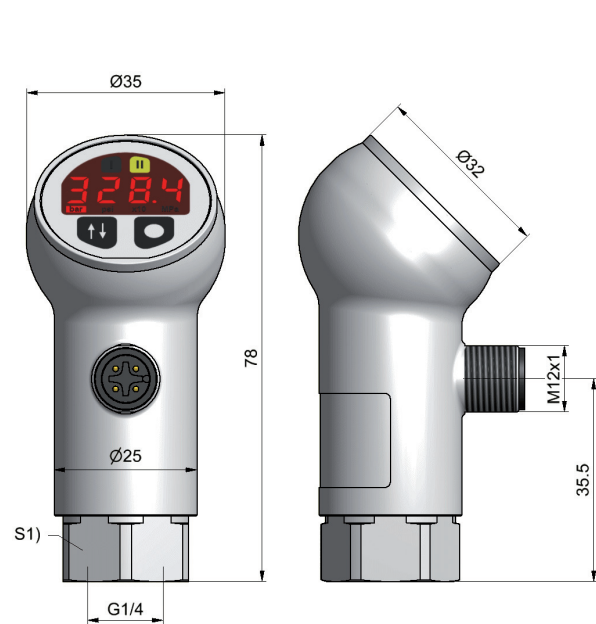

SCSD-S22

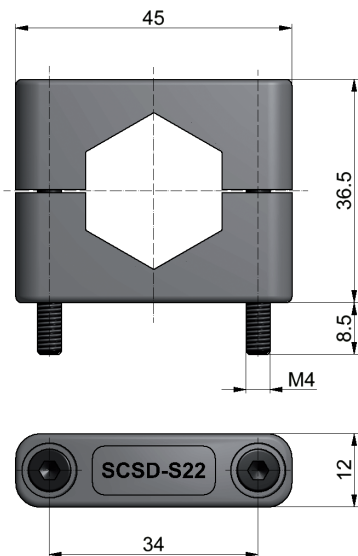

The Controller Family



# SCPSDi PressureController

## SCPSDi-xxx-x5-17

1/4 NPT  
L1) 75.5  
L2) 33

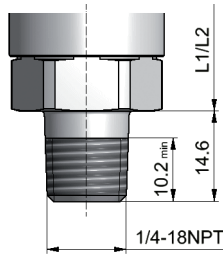

## Order code

**SCPSDi 2 switching outputs;**  
**SCPSDi 2 switching outputs Marine; SCPSDi-xxx-04-x7-MA**  
(approved by DNV/GL/ABS)  
without analogue output,  
G 1/4, M12x1; 4-pole

**1 switching output;**  
**1 switching output Marine;**  
(approved by DNV/GL/ABS)  
switchable analogue output,  
G 1/4, M12x1; 4-pole

SCPSDi-xxx-04-x7-  
SCPSDi-xxx-14-x7  
SCPSDi-xxx-14-x7-MA

## SCPSDi-xxx-x7-17

7/16UNF  
L1) 78  
L2) 35.5  
X1) OR 8.92x1.83

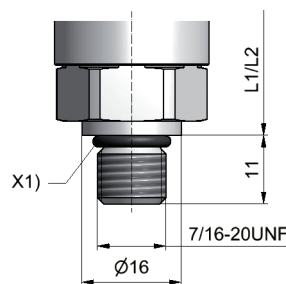

## Pressure range

010	010
016	016
025	025
060	060
100	100
250	250
400	400
600	600

## Version

Outer thread	1
Inner thread	2

## SCPSDi-xxx-x4-17

G1/4ED  
L1) 77.5  
L2) 35  
X1) ED seal

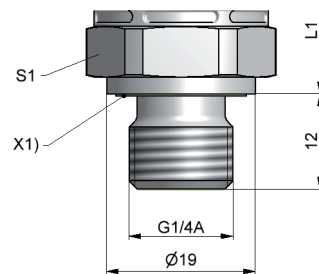

## Connection cable and single plug

**Connection cable, assembled**  
(open cable end)

SCK-400-xx-xx

## Cable length (m)

2 m	02
5 m	05
10 m	10

## Connecting plug

M12 cable jack; straight	45
M12 cable jack; 90° angled	55

## Single connector

M12 cable jack; straight	SCK-145
M12 cable jack; 90° angled	SCK-155

## Accessories:

Securing clamp	SCSD-S27
----------------	----------

## SCPSDi-xxx-x4-27

G1/4

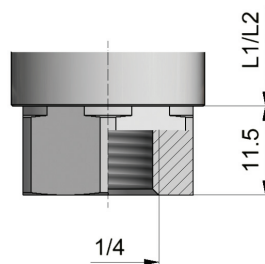

# SCPSD PressureController

## Device features

- Compact size
- Rugged
- Dependable
- Easily operable
- Long-term stability
- Excellent interference immunity
- Metal housing
- High protection class
- Many variants
- Pivoting
- Analogue output
- Password
- MPa, bar, PSI



The PressureController combines the functions of a pressure switch, a pressure sensor and a display device.

- Pressure gauge (manometer)
- Switching outputs
- Analogue signal

The PressureController is easy to operate, has a compact design and is very reliable. The PressureController features excellent technical specifications, optimal pressure management and a wide variety of installation options. This makes it perfect for permanent series use in industrial applications.

### Easy to use

The parameters are set using the keys or over a programming module.

### High functionality

Each switching output can be adjusted individually:

- NO/NC contact
- On/off switching pressures
- Delay times
- Hysteresis / window function
- Attenuation

Thanks to these easy switching functions, intelligent adjustments can be set which are normally not possible using a mechanical switch. Therefore, many switches can be replaced with one controller.

The analogue output is individually adjustable

- 0/4...20 mA switchable
- Starting pressure selectable
- End pressure selectable

### Reliable and safe

The pressure is recorded with a long term stable measuring cell. A functional error is signalled and can be processed further according to DESINA. Parameters can be password protected to avoid unauthorised changes.

### Rugged

The housing is made of metal and is resistant to moisture, shock and vibrations. The electronics are protected against reverse polarity, over-voltage and short-circuits.

### Everything at a glance

The large illuminated display can be read from long distances. The pressures can be displayed in MPa, bar or PSI.

### Optimal installation possibilities

The SCPSD is ideal for installation under critical conditions because of its compact design and excellent interference immunity. The display is always easy to read because the housing can be positioned as needed.

### Universal

Diverse versions are available for the many different applications.



# SCPSD PressureController

## Device features

### Everything at a glance

- Sloped display
- Digital display
  - Large
  - Illuminated
- Display
  - PSI/bar/Mpa
  - Current pressure
  - Minimum pressure
  - Maximum pressure
  - Switching points

### Variable installation

- Compact size
- 290° pivotable

### Pressure port

- Stainless steel
- Long term stable measuring cell
- Wide range of compatible substances

### Thread

- Inner thread

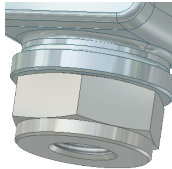

- Outer thread



### Optical interface

- Switch status is shown

### Easy to use

- 3 large buttons
- Display of the unit

### Rugged

- Metal housing
- Waterproof
- Excellent interference immunity
- Vibration proof
- Shock proof

### Tube clamp

- Safe installation with the sturdy SCSD-S27 clamp



### Programming module

- Adjustable through ControllerWIN Software

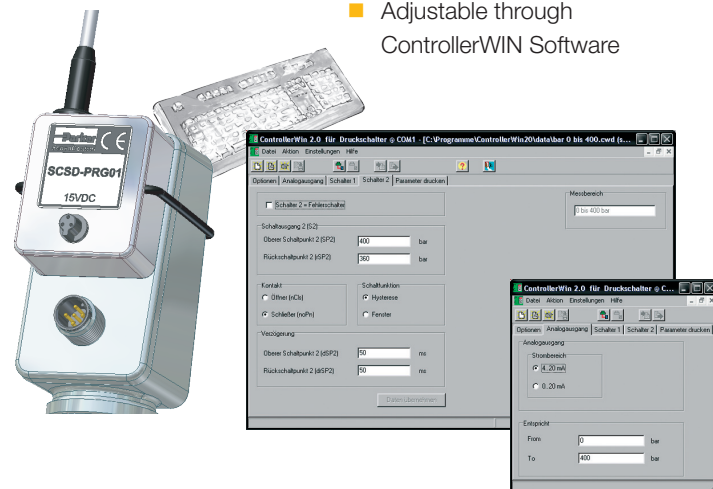

# SCPSD PressureController

## Technical data

SCPSD-	004	010	016	060	100	250	400	600
Pressure range $P_n$ relative (bar)	-1...4	-1...10	-1...16	0...60	0...100	0...250	0...400	0...600
Adjusting range RSP...SP								
Overload pressure $P_n$ (bar)	10	20	40	120	200	500	800	1200
Burst pressure $P_n$ (bar)	12	25	50	550	800	1200	1700	2200
Display resolution (bar)	0.01	0.01	0.01	0.1	0.1	1	1	1
Smallest adjustable difference between SP and RSP (SP-RSP)	0.03	0.06	0.09	0.3	0.6	2	3	3
Measuring component	Ceramic			Thin film DMS				
Parts in contact with substances	Stainless steel 1.4404; Ceramic AL2O3; NBR			Stainless steel 1.4404; 1.4542				

Input parameters	
Switching cycles	≥ 100 million
Polling rate	≥ 5 ms
Connector thread	G1/4 BSPP; ED soft seal NBR* (DIN 3852 T2, Form X); ED (DIN3852 T11, Form E)
Tightening torque	35 Nm
Temperature range of substance	-20...+85 °C
Weight	Approx. 300 g
MTTFd	> 100 years
Output values	
Accuracy	± 0.5 % FS typ.; ± 1 % FS max.
Temperature drift	± 0.02 % FS/°K type (at -20...+85 °C) ± 0.03 % FS/°K max.
Long-term stability	± 0.2 % FS/a
Repeat accuracy	± 0.25 % FS
Switching point accuracy	± 0.5 % FS typ.; ± 1 % FS max.
Display accuracy	± 0.5 % FS type ± 1 Digit ± 1 % FS max. ± 1 Digit
Response speed	
Switching output	≤ 10 ms
Analogue output	≤ 10 ms

Electrical connection	
Supply voltage $V_s$	15 to 30 VDC nominal 24 VDC; Protection class 3
Electrical connection	M12x1; 4-pole; 5-pole; with gold-plated contacts device connector
Short-circuit protection	Yes
Protection against wrong insertion	Yes
Overload protection	Yes
Current consumption	< 100 mA
Housing	
	Adjustable direction to 290°C
Material	Painted zinc die cast Z 410
Foil material	Polyester
Display	4-digit 7-segment LED; red; digit height 9 mm
Protection degree	IP67 DIN EN 60529;

# SCPSD PressureController

## Technical data

Ambient conditions	
Ambient temperature range	-20...+85 °C
Storage temperature range	-40...+100 °C
Vibration resistance	20 g; 10...500 Hz IEC60068-2-6**
Shock resistance	50 g; 11 ms IEC60068-2-29**
EM compatibility	
Disturbance emissions	EN 61000-6-3
Resistance to interference	EN 61000-6-2
Outputs	
Switching outputs	Two MOSFET high-side switches (PNP)
Contact functions	NO / NC contact; window / hysteresis; function freely adjustable
Switching voltage	$V_+ - 1.5 \text{ VDC}$
Switching current max.	0.5 A per switch
Short-circuit current	2.4 A per switch
Analogue output	0/4...20 mA; programmable; freely scalable; $RL \leq (\text{Supply voltage} - 8 \text{ V}) / 20 \text{ mA} (\leq 500 \Omega)$

\* different sealing material (FKM, EPDM etc.) upon request  
 \*\* does not apply for version DIN EN 175301-803 Form A (old DIN43650)

### Information about selecting the pressure range

The following parameters are relevant when working with pressure switches:

- System pressure
- Switching point pressure

Since a 400-bar pressure switch has a comparable resolution (of 1 bar) as that of a 600-bar pressure switch (also 1 bar), it is possible to use a 600-bar pressure switch even when there is a smaller nominal pressure (for example, 315 bar).

This is a positive feature because it provides the same precision with improved safety and fewer product variants.

## Pin assignment

### SCPSD-xxx-14-x7

1 switching and 1 analogue output

M12x1; 4-pole

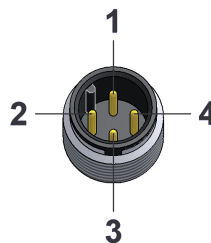

PIN	Assignment
1	$V_+$
2	Analogue out
3	0 V / GND
4	S1 out

### SCPSD-xxx-04-x7

2 switching outputs;

M12x1; 4-pole

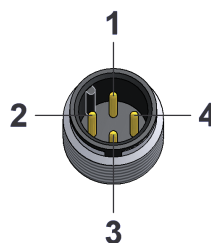

PIN	Assignment
1	$V_+$
2	S2 out
3	0 V / GND
4	S1 out

### SCPSD-xxx-14-x5

2 switching outputs; 1 analogue output;

M12x1; 5-pole

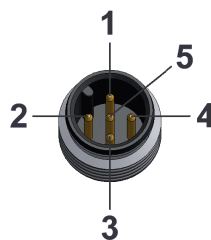

PIN	Assignment
1	$V_+$
2	S2 out
3	0 V / GND
4	S1 out
5	Analogue out

# SCPSD PressureController

## Outer thread

SCPSD-xxx-x4-1x

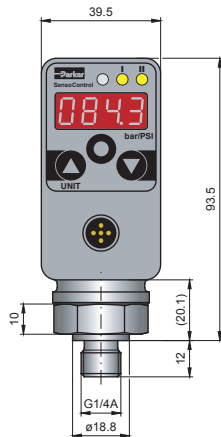

## Inner thread

SCPSD-xxx-x4-2x

Up to 10 bar

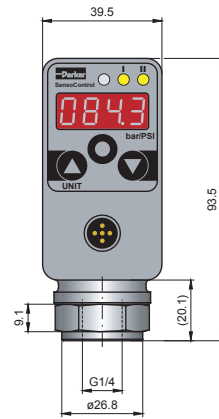

From 16 bar

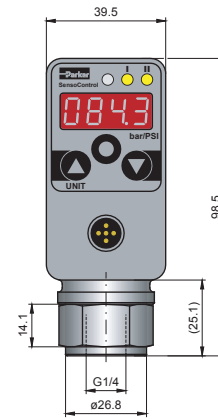

## M12 connecting plug

SCPSD-xxx-x4-x5

## Clamp (accessory)

SCSD-S27

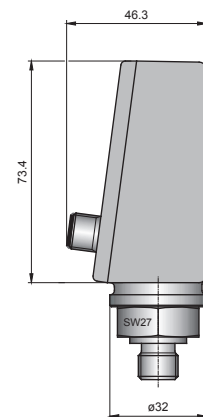
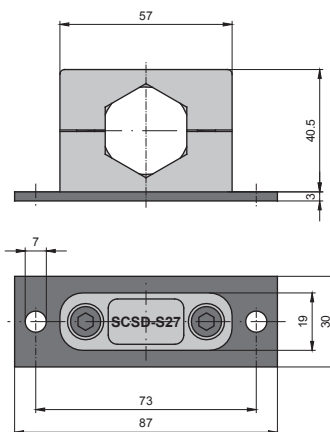

The Controller Family



# SCPSD PressureController

## Order code

### SCPSD digital pressure switch

**2 switching outputs; no analogue output: SCPSD-xxx-04-x7**

M12x1 connecting plug; 4-pole

**1 switching output; with analogue output: SCPSD-xxx-14-x7**

M12x1 connecting plug; 4-pole

**2 switching outputs; with analogue output SCPSD-xxx-14-x5**

M12x1 connecting plug; 5-pole

### Pressure range

004	004
010	010
016	016
060	060
100	100
250	250
400	400
600	600

### Version

G1/4 BSPP outer thread	1
G1/4 BSPP inner thread	2

### Accessories:

- PC Programming KIT
- Securing clamp
- Reducing adapter M22x1.5
- Reducing adapter G1/2 BSPP
- Attenuation adapter
- Attenuation adapter
- Flange adapter
- for mechanical pressure switch

- SCSD-PRG-KIT
- SCSD-S27
- SCA-1/4-M22x1.5-ED
- SCA-1/4-ED-1/2-ED
- SCA-1/4EDX1/4-D
- SCA-1/2EDX1/2-D
- SCAF-1/4-40

## Connection cable and single plug

### Connection cable, assembled

(open cable end)

SCK-400-xx-xx

### Cable length (m)

2 m	02
5 m	05
10 m	10

### Connecting plug

M12 cable jack; straight	45
M12 cable jack; 90° angled	55

### Single connector

M12 cable jack; straight	SCK-145
M12 cable jack; 90° angled	SCK-155

## Order example

### SCPSD-100-04-27

- Pressure range 100 bar
- 2 switching outputs
- G1/4 BSPP inner thread
- M12 connecting plug



### SCPSD-004-14-17

- Pressure range 4 bar
- 1 switching output
- 1 analogue output
- G1/4 BSPP outer thread
- M12 connecting plug



# SCTSD TemperatureController

## Device features

- Compact size
- Rugged
- Dependable
- Easily operable
- Metal housing
- High protection class
- Modular construction
- Many variants
- Analogue output
- Pivoting
- Password
- °C, °F

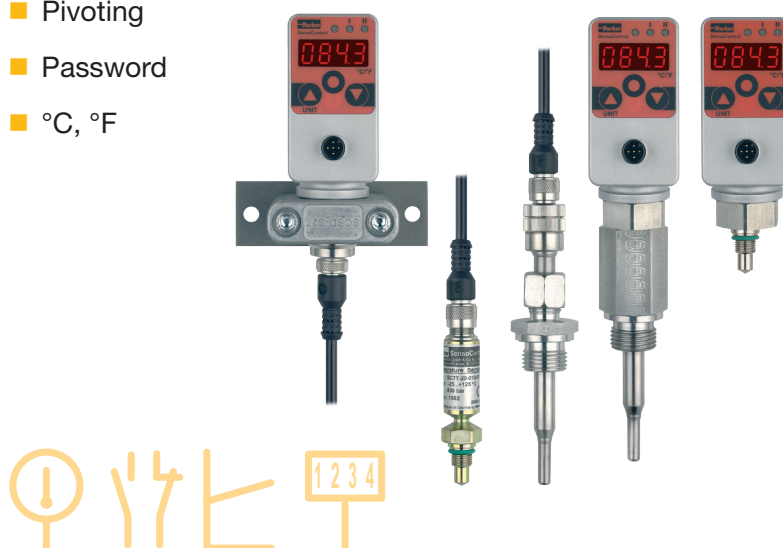

The TemperatureController combines the functions of a temperature switch, a temperature sensor and a display device.

- Temperature display (Thermometer)
- Switching outputs
- Analogue signal

Simple operation, extensive functionality and a modular design are the most important characteristics of the TemperatureController.

The TemperatureController offers excellent technical specifications, optimum temperature management, combined with a variety of installation options. It is perfect for applications when the temperature needs to be reliably monitored and easily viewed.

### Easy to use

The normal temperature monitoring limit values adjustments (e.g. cooling and alarm) are made either with the keys or the programming module.

### High functionality

Each switching output can be adjusted individually:

- NO/NC contact
- On/off switching pressures
- Delay times
- Hysteresis / window function
- time delay

Thanks to these easy switching functions, intelligent adjustments can be set which are normally not possible using a mechanical switch. Therefore, many switches can be replaced with one controller.

The analogue output is individually adjustable

- 0/4...20 mA switchable
- Adjustable start temperature
- Adjustable end temperature

### Reliable and safe

A functional error is signalled and can be processed further according to DESINA. Parameters can be password protected to avoid unauthorised changes.

### Rugged

The housing is made of metal and is resistant to moisture, shock and vibrations. The electronics are protected against reverse polarity, over-voltage and short-circuits.

### Everything at a glance

The large illuminated display can be read from long distances. The temperature can be selected to °C or °F. The temperature is always optimally readable due to the modular construction and the pivoting housing.

### Optimal installation possibilities

Sensors in various lengths are available for different tank sizes. These can be directly connected to the TemperatureController via a cable. Additionally the temperature sensor is available up to 630 bar for high pressure applications.

### Universal

Diverse versions are available for the many different applications.



# SCTSD TemperatureController

## Application example Tank temperature monitoring

### Machine On / Off

The facility should shut down when the tank temperature falls below 10°C or climbs above 60°C.

A protective wire-break mechanism should be considered to improve safety.

### Cooling

If the temperature climbs above 50°C, the tank temperature should be cooled with a refrigerating unit down to 40°C.

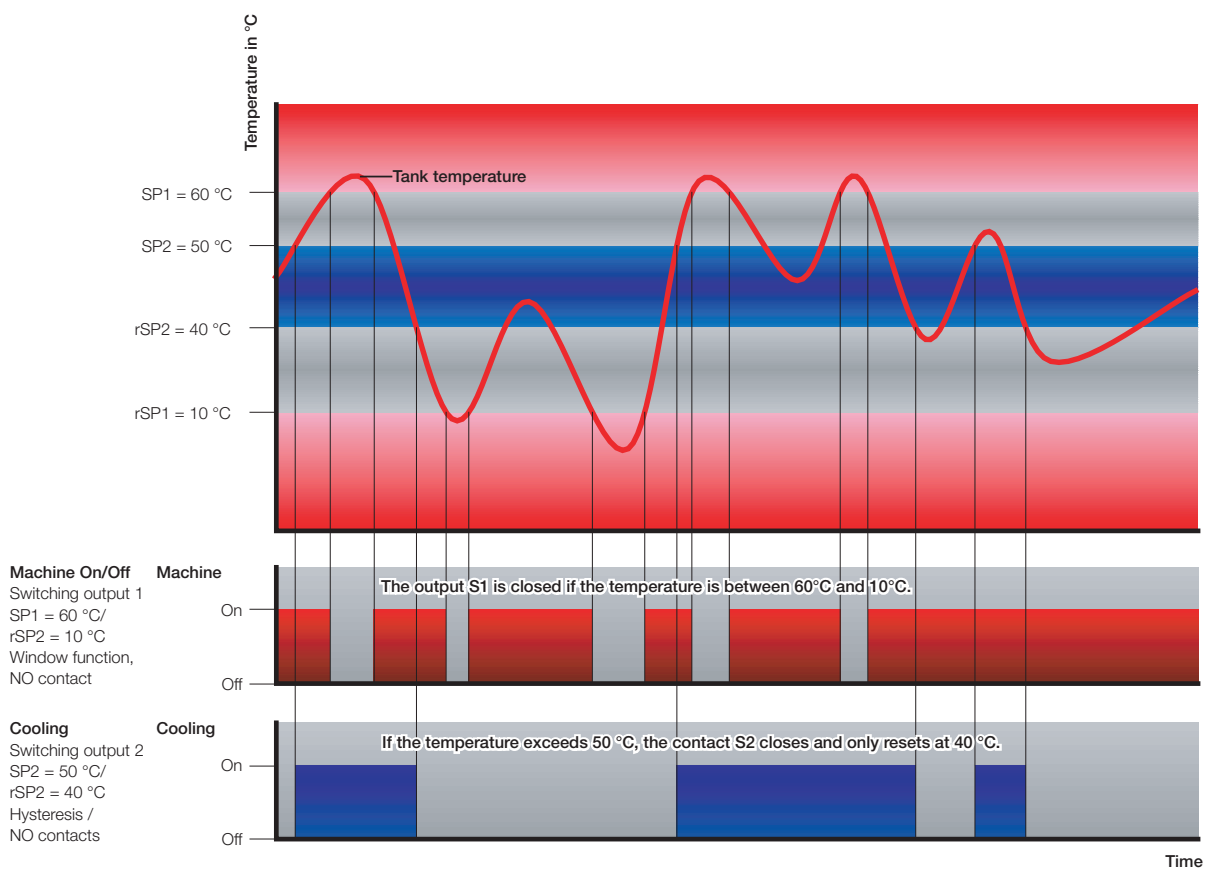

The Controller Family



# SCTSD Modular Temperature Controller

## Device features

### Everything at a glance

- Sloped display
- Digital display
  - Large
  - Illuminated
- Display
  - °C, °F
  - Current temperature
  - Minimum temperature
  - Maximum temperature
  - Switching points

### Variable installation

- Compact size
- 290° pivotable

### Connect as required

- 2 switching outputs
- Analogue output
- 0...20 or 4...20 mA
- Freely programmable
- Scalable
- Plug
  - M12
  - DIN EN 175301-803 Form A (old DIN43650)



### Optical interface

- Switch status is shown

### Easy to use

- 3 large buttons
- Display of the unit

### Rugged

- Metal housing
- Waterproof
- Excellent interference immunity
- Vibration proof
- Shock proof

### Tube clamp

- Safe installation with the sturdy SCSD-S27 clamp



### Programming module

- Adjustable through ControllerWIN Software

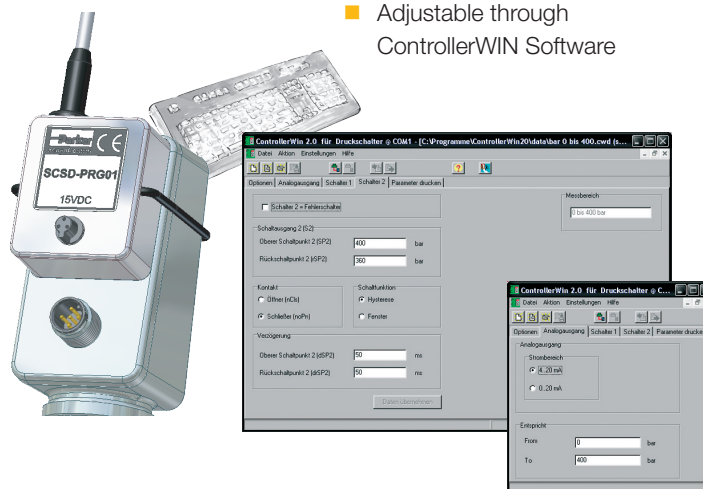

The Controller Family

# SCTSD Modular Temperature Controller

## Device features

### Adjustable height

Through clamping thread

- SCA-TT-10-1/2



### High pressure temperature sensor

- 630 bar
- SCTT-20-010-07



### Immersion tube

Additional with

- High pressures
- Aggressive substance
- Immersion tube SCA-TT-10-xxx



### Cable

- SCK-410-03-45-45



### Temperature sensor

- Stainless steel
- Wide range of compatible substances
- Diverse lengths
- SCTT-10-xxx-07

### Connection adapter

- SCA-TT-10-SD

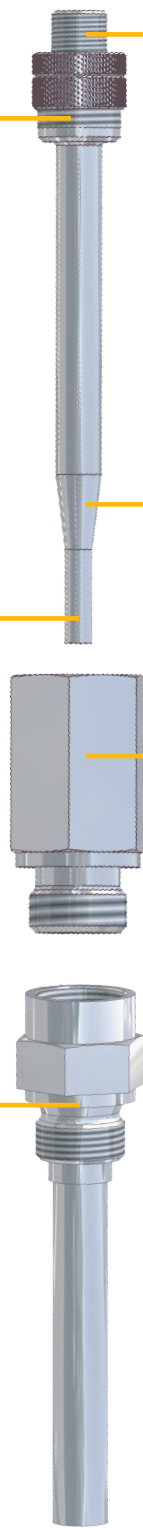

# SCTSD Modular Temperature Controller

## Technical data

Input parameters SCT-150	
Display range	-50...+150 °C
Sensor input	PT1000
Sensor connection	M12x1; 4-pole
Output values	
Switching accuracy at 25 °C	± 0.35 % FS
Display accuracy at 25 °C	± 0.35 % FS ± 1 Digit
Electrical connection	
Supply voltage V <sub>+</sub>	15...30 VDC nominal 24 VDC; Protection class 3
Electrical connection	M12x1; 4-pole; 5-pole; Device plug DIN EN 175301-803 Form A (old DIN43650)
Short-circuit protection	Yes
Overload protection	Yes
Current consumption	< 100 mA
EM compatibility	
Disturbance emissions	EN 61000-6-3
Resistance to interference	EN 61000-6-2

\* does not apply for version DIN EN 175301-803 Form A (old DIN43650)

Temperature sensor SCTT-10-xxx-07	
Measuring component	PT1000/DIN EN 60751, Class B
Measuring range	-40...+125 °C
Response time	$\tau_{0.5} = 6 \text{ s} / \tau_{0.9} = 25 \text{ s}$
Accuracy	± 0.3 K + 0.005* t
Material	Stainless Steel 1.4571
Nominal pressure (max)	10 bar
Temperature of substance	-40...+125 °C
Ambient temperature	-25...+80 °C (for the connector area)
Storage temperature	-25...+85 °C

Housing	
	Orientation adjustable to 290°
Material	Die-cast zinc Z 410; painted
Foil material	Polyester
Display	4-digit 7-segment LED; red; digit height 9 mm
Protection degree	IP67 EN 60529 IP65 with device plug DIN EN 175301-803 Form A (old DIN43650)
Ambient conditions	
Ambient temperature range	-20...+85 °C
Storage temperature range	-40...+100 °C
Vibration resistance	20 g; 10...500 Hz IEC60068-2-6*
Shock resistance	50 g; 11 ms IEC60068-2-29*
Outputs	
Switching outputs	2 x PNP high-side switch, 0.7 A/switch
Contact functions	NO / NC contact; window / hysteresis
Response speed	300 ms
Accuracy	± 1 % FS
Analogue output	0/4...20 mA; programmable; freely scalable; 4...20 mA = -40...125 °C

High pressure sensor SCTT-20-010-07	
Measuring component	PT1000/DIN EN 60751, Class B
Measuring range	-40...+125 °C
Response time	$\tau_{0.5} = 3 \text{ s} / \tau_{0.9} = 15 \text{ s}$
Accuracy	± 0.3 K + 0.005*t
Material	Stainless Steel 1.4404
Threaded stud	M10x1
Seal	O ring 7.65x1.78 mm; FKM
Measuring pipe diameter	7 mm
Installation length	18.5 mm
Nominal pressure P <sub>n</sub>	630 bar
Overload pressure P <sub>max</sub>	800 bar
Burst pressure P <sub>burst</sub>	1200 bar
Temperature of substance	-40...+125 °C
Ambient temperature	-25...+80 °C (for the connector area)
Storage temperature	-25...+85 °C

# SCTSD Modular Temperature Controller

## Pin assignment

### SCTSD-150-00-06

1 switching output  
DIN EN 175301-803 Form A 4-pole (old 43650)

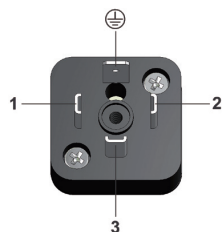

PIN	Assignment
1	V <sub>+</sub>
2	0 V / GND
3	S1 out
	-

### SCTSD-150-00-07

2 switching outputs  
M12x1; 4-pole

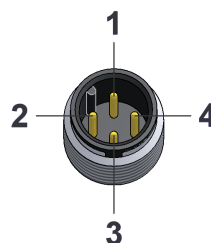

PIN	Assignment
1	V <sub>+</sub>
2	S2 out
3	0 V / GND
4	S1 out

### SCTSD-150-10-07

1 switching output, 1 analogue output  
M12x1; 4-pole

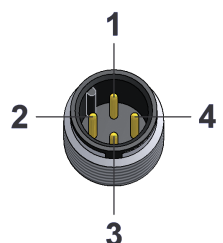

PIN	Assignment
1	V <sub>+</sub>
2	Analogue out
3	0 V / GND
4	S1 out

### SCTSD-150-10-05

2 switching outputs, 1 analogue output  
M12x1; 5-pole

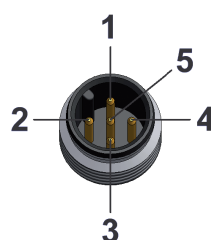

PIN	Assignment
1	V <sub>+</sub>
2	S2 out
3	0 V / GND
4	S1 out
5	Analogue out

### SCTT-x0-xxx-07

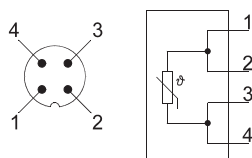

Measuring range	Display resolution Increment size	Lowest reset switch point RSP	Largest switching value SP	Smallest adjustable difference between SP and RSP (SP-RSP)
-50...150 °C	0.1 °C	-50 °C	150 °C	0.8

# SCTSD Modular Temperature Controller

## M12 connecting plug

SCTSD-150-x4-05

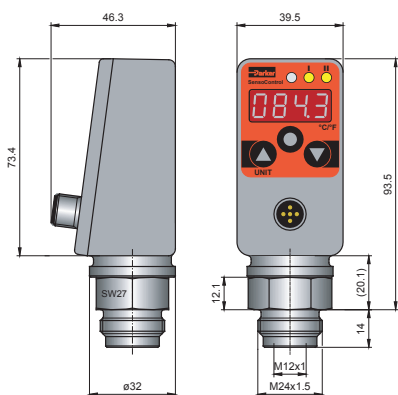

## DIN 43650

SCTSD-xxx-00-06

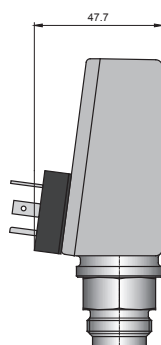

## High pressure temperature sensor

SCTT-20-010-07

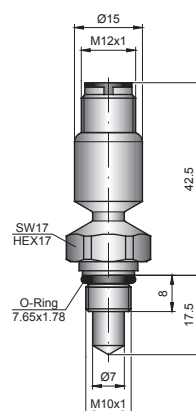

## Temperature sensor

SCTT-10-xxx-07

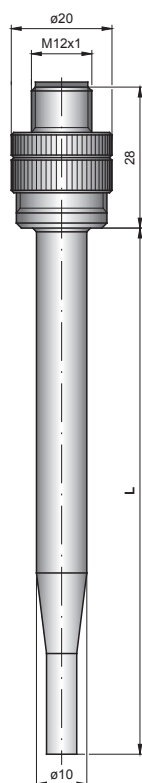

## Connection adapter (accessory)

SCA-TT-10-SD

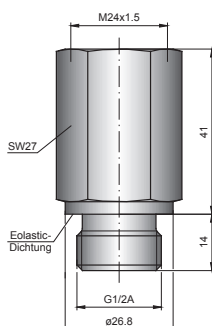

## Clamping thread (accessory)

SCA-TT-10-1/2

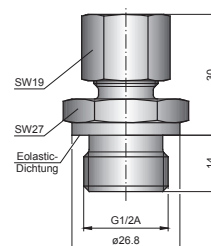

**Material:**  
Stainless Steel 1.4404  
**Male stud:**  
G1/2A BSPP DIN3852-E  
**Seal type:**  
ED (Eolastic seal type)  
**Screw plug hole**  
G1/2A BSPP DIN3852-E  
**Replacement seals:**  
ED1/2VITX (FKM)

**GE10LR1/2EDOMD71:**  
(with 10 mm bore hole)  
Stainless Steel 1.4571  
**EO-2-functional nut:**  
FM10L71  
**Male stud:**  
G1/2A BSPP DIN3852-E  
**Seal type:**  
ED (Eolastic seal type)  
**Replacement seal:**  
ED1/2VITX (FKM)

# SCTSD Modular Temperature Controller

## Sensor cable 3 m (accessory)

SCK-410-03-45-45



## Clamp (accessory)

SCSD-S27

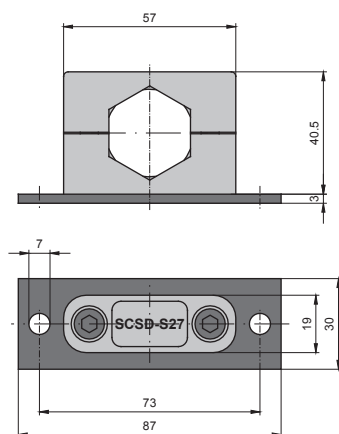

## Order code

### SCTSD module

**1 switch output; no analogue output** SCTSD-150-00-06

DIN EN 175301-803 Form A  
(old DIN 43650) connecting plug

**2 switch outputs; no analogue output** SCTSD-150-00-07

M12x1 connecting plug; 4-pole

**1 switch output; with analogue output** SCTSD-150-10-07

M12x1 connecting plug; 4-pole

**2 switch outputs; with analogue output** SCTSD-150-10-07

M12x1 connecting plug; 5-pole

### Accessories:

- Securing clamp
- Sensor cable 3 m (SCTSD-SCTT)
- Clamping thread G1/2 BSPP
- Connection adapter (SCTSD-SCTT)
- High pressure temperature sensor
- Immersion tube G1/2 BSPP

- SCSD-S27
- SCK-410-03-45-45
- SCA-TT-10-1/2
- SCA-TT-10-SD
- SCTT-20-10-07
- SCA-TT-10-xxx

### Length mm

100 mm	100
150 mm	150
250 mm	250

## Order example

### Components for the control panel - high pressure version

- Securing clamp **SCSD-S27**
- Sensor cable 3 m (SCTSD-SCTT) **SCK-410-03-45-45**
- High pressure temperature sensor **SCTT-20-10-07**

### Components for the control panel

- Securing clamp **SCSD-S27**
- Sensor cable 3 m (SCTSD-SCTT) **SCK-410-03-45-45**
- Clamping thread G1/2 BSPP **SCA-TT-10-1/2**
- Temperature sensor 150 mm **SCTT-10-150-07**
- Optional: Immersion tube G1/2 BSPP 100 mm **SCA-TT-10-100**

### Direct mounting components

- Connection adapter (SCTSD-SCTT) **SCA-TT-10-SD**
- Temperature sensor 100 mm **SCTT-10-100-07**
- Optional: Immersion tube G1/2 BSPP 200 mm **SCA-TT-10-200**

### Temperature sensor

SCTT-10-xxx-07

### Length mm

100 mm	100
150 mm	150
250 mm	250

## Connection cable and single plug

### Connection cable, assembled

SCK-400-xx-xx

(open cable end)

### Cable length (m)

2 m	02
5 m	05
10 m	10

### Connecting plug

M12 cable jack; straight	45
M12 cable jack; 90° angled	55

### Single connector

M12 cable jack; straight	SCK-145
M12 cable jack; 90° angled	SCK-155

# SCTSD high pressure Temperature Controller

## Device features

### Everything at a glance

- Sloped display
- Digital display
  - Large
  - Illuminated
- Display
  - °C, °F
  - Current temperature
  - Minimum temperature
  - Maximum temperature
  - Switching points

### Rugged

- Metal housing
- Waterproof
- Excellent interference immunity
- Vibration proof
- Shock proof

### Variable installation

- Compact size
- 290° pivotable

### Programming module

- Adjustable through ControllerWIN Software

### Optical interface

- Switch status is shown

### Easy to use

- 3 large buttons
- Display of the unit

### Connect as required

- 2 switching outputs
- Analogue output
- 0...20 or 4...20 mA
- Freely programmable
- Scalable
- M12 connecting plug

### High pressure resistance

- Up to 630 bar

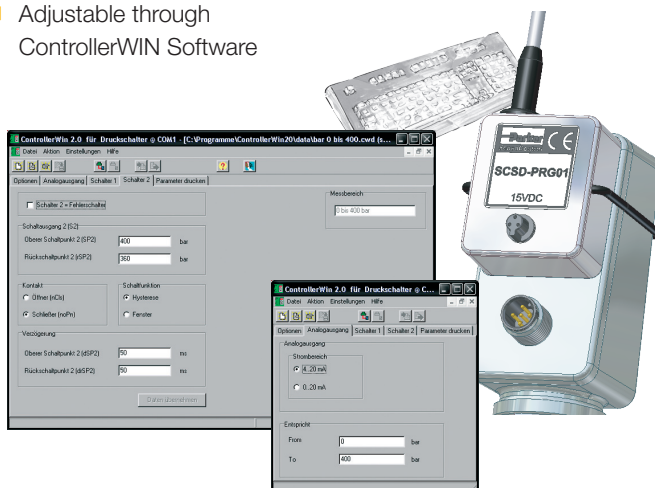
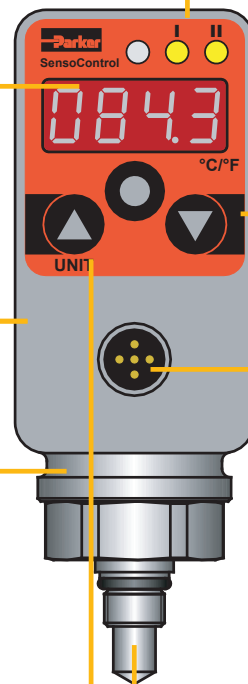

The Controller Family



# SCTSD high pressure TemperatureController

## Technical data

Input values SCTSD-150-x2-0x	
Measuring range	-40...+100 °C
Input for measuring element	PT1000/DIN EN 60751; Class B
Range of use	Liquid media, air
Output values	
Switching accuracy at 25 °C	± 0.35 % FS
Display accuracy at 25 °C	± 0.35 % FS ± 1 Digit
Temperature margin of error	± 0.01 % FS/°C typ. (for -20...+85 °C)
Long-term stability	± 0.2 % FS/a
Electrical connection	
Supply voltage $V_+$	15 to 30 VDC (with protection against polarity reversal)
Electrical connection	M12x1; 4-pole; 5-pole; with gold-plated contacts
Short-circuit protection	Yes
Overload protection	Yes
Current consumption	< 100 mA
Mechanical connection	
Threaded male stud	M10x1
Seal	O-ring 7.65x1.78 mm; FKM
Measuring pipe diameter	7 mm
Installation length	18.5 mm
Material	Stainless Steel 1.4404
$P_N$ pressure	630 bar
$P_{max}$	800 bar
Burst pressure	1200 bar
Housing	
	Adjustable direction to 290°C
Material	Die-cast zinc Z 410; painted
Foil material	Polyester
Display	4-digit 7-segment LED; red; digit height 9 mm
Protection degree	IP67 EN 60529

Ambient conditions	
Ambient temperature range	-25...+80 °C
Storage temperature range	-25...+85 °C
Media temperature range	-40...+100 °C
Vibration resistance	20 g; 10...500 Hz IEC60068-2-6*
Shock resistance	50 g; 11 ms IEC60068-2-29
EM compatibility	
Disturbance emissions	EN 61000-6-3
Resistance to interference	EN 61000-6-2
Outputs	
Switching outputs	2 x PNP high-side switch
Contact functions	NO / NC contact; window / hysteresis
Switching current:	0.5 A / switch to 85 °C; 0,7 A / switch to 70 °C
Response speed	≤ 0.7 s maximum load current
Optional analogue output	
Measuring range	0/4...20 mA
Response speed (0-95 %)	≤ 300 ms
Analogue output error	± 1 % FS
Load	≤ 500 Ω from $V_+$ > 18 VDC

# SCTSD high pressure TemperatureController

## M12 connecting plug

SCTSD-150-x4-05

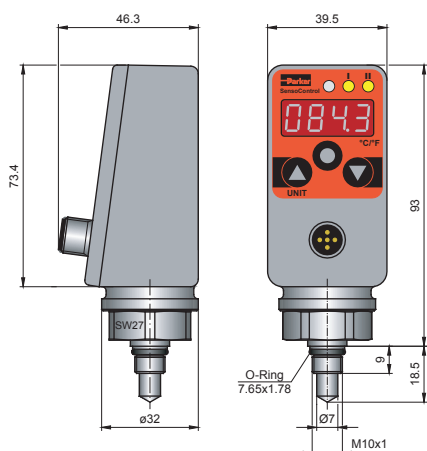

## Pin assignment

### SCTSD-150-02-07

2 switching outputs  
M12x1; 4-pole

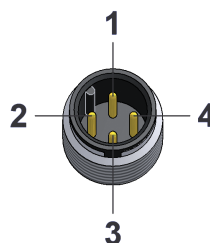

PIN	Assignment
1	V <sub>+</sub>
2	S2 out
3	0 V / GND
4	S1 out

### SCTSD-150-12-07

1 switching output, 1 analogue output  
M12x1; 4-pole

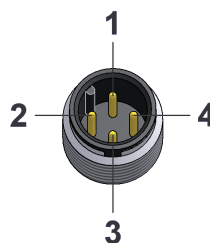

PIN	Assignment
1	V <sub>+</sub>
2	Analogue out
3	0 V / GND
4	S1 out

### SCTSD-150-12-05

2 switching outputs, 1 analogue output  
M12x1; 5-pole

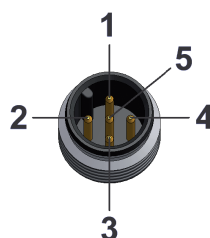

PIN	Assignment
1	V <sub>+</sub>
2	S2 out
3	0 V / GND
4	S1 out
5	Analogue out

Measuring range	Display resolution Increment size	Lowest reset switch point RSP	Largest switching value SP	Smallest adjustable difference between SP and RSP (SP-RSP)
-40...100 °C	0.1 °C	-40 °C	100 °C	0.8



# SCTSD high pressure TemperatureController

## Order code

### SCTSD high pressure

**2 switch outputs; no analogue output**    **SCTSD-150-02-07**  
M12x1 connecting plug; 4-pole

**1 switch output; with analogue output**    **SCTSD-150-12-07**  
M12x1 connecting plug; 4-pole

**2 switch outputs; with analogue output**    **SCTSD-150-12-05**  
M12x1 connecting plug; 5-pole

### Accessories

**PC Programming Kit**                                    **SCSD-PRG-KIT**

## Connection cable and single plug

**Connection cable, assembled**                    **SCK-400-xx-xx**  
(open cable end)

### Cable length (m)

2 m	02
5 m	05
10 m	10

### Connecting plug

M12 cable jack; straight	45
M12 cable jack; 90° angled	55

### Single connector

M12 cable jack; straight	<b>SCK-145</b>
M12 cable jack; 90° angled	<b>SCK-155</b>

# SCTSD-L combination switch

## Device features

- Compact design
- Temperature display
- Individually adjustable temperature switching outputs
- Small switching hysteresis
- Preset
  - For standard oils
  - For cooling
  - For switching off ( $T_{max}$ )
- Fixed level contacts
- Only one float
- Preset level
  - Warning and shutdown min.
  - Shut-down min./max.
- Up to one meter probe length



The SCTSD-L combination switch was designed to meet the requirements of hydraulic facility construction. It combines the functions of a fixed mechanical level switch with an adjustable temperature switch with display.

### Level

The tank level is measured using a highly dynamic, fully encapsulated magnetic float which switches the bi-stable reed contacts. The M12 pin assignments are compatible with conventional existing systems. The level contacts are pre-determined according to the normal tank sizes. There are two standard switch output versions available:

- Warning minimum level and shutdown minimum level
- Shutdown maximum and minimum levels

The switching positions were chosen according to the proven experiences of plant constructors and the DIN. For safety reasons (fail-safe / closed circuit), the switching behaviour of the standard switch is an NC contact.

Optionally the contacts can be changed at the factory and pre-set in line with the customer's requirements.

### Temperature

The temperature is detected using a sensor; it is then evaluated and constantly displayed using the SCTSD TemperatureController (as described in the SCTSD section). Thanks to the easy switching functions (e.g. switching windows), intelligent switching settings can be achieved that are not possible using a mechanical temperature switch.

Normally the outputs for the normal temperature functions cooling on/off and shutdown are pre-installed as standard. The temperature thresholds were designed for standard oils (HLP).

It is possible to adjust the temperature monitoring temperature limits (e.g. cooling and shutdown) for each output individually using the keys:

- On/off switching temperature limits
- NO/NC contact
- Hysteresis / window function
- Time delay and attenuation

Optional (see: SCTSD-L-....-KIT5 ) 3 different versions of temperature switching outputs are available:

- 2 switching outputs
- 1 switching and 1 analogue output
- 2 switching outputs and one analogue output



# SCTSD-L combination switch

## Technical data

General	
Measurement principle	Magnetic float reed switches
Float	NBR, Ø 18 mm, length 25 mm, magnetic
Viscosity	Max. 250 cSt at 25 °C
Density	at least 0.750 g/cm <sup>3</sup>
Connector thread	G3/4 outer thread
Protection tube	Ø 8 mm
Probe length Lmax	Lowest switching point + 35 mm
Operating pressure	1 bar max.
Accuracy	±2 mm
Material	
Protection tube	Brass
Connector thread	Brass
Ambient conditions	
Temperature of substance	-20...+85 °C
Storage temperature	-40...+100 °C

Preset temperatures	
Switching output 1*	50 °C contact closed (cooling on)
	45 °C contact open (cooling off)
Switching output 2*	63 °C contact open (shutdown)
	60 °C contact closed
Level switching outputs	
Switching current:	0.5 A max.
Switching voltage	100 V max.
Switching power	10 W max.
Switching function	NO or NC (bi-stable)
Contact material	Rhodium
Plug	M12x1; 4 pin
Smallest difference between L1 and L2	30 mm
Smallest switching position L1	30 mm from the tank lid

\*) Each temperature switching output can be individually re-programmed or adjusted:

- NO/NC contact
- On/off switching temperature
- Hysteresis / window function
- Time delay and attenuation

## Fill level pin assignments

M12x1; 4-pole

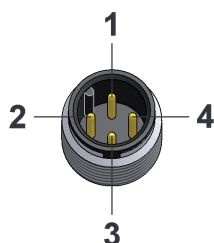

PIN	Assignment
1	IN
2	OUT S2
3	n.c.*
4	OUT S1

\*n.c. = do not connect

# SCTSD-L combination switch

## Temperature pin assignment

**SCTSD-150-0X-0X**  
(Refer chapter SCTSD)

**SCTSD-L-xxxxO-xxFO**  
**SCTSD-L-xxxxx-xxxxx-KIT5**  
2 switching outputs  
M12x1; 4-pole

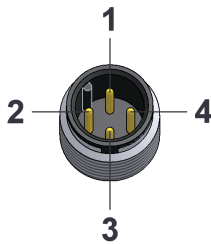

PIN	Assignment
1	V <sub>+</sub>
2	S2 out
3	0 V / GND
4	S1 out

**SCTSD-L-xxxxx-xxxxx-17-KIT5**  
1 switching output, 1 analogue output  
M12x1; 4-pole

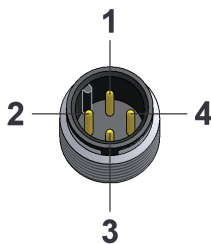

PIN	Assignment
1	V <sub>+</sub>
2	Analogue out
3	0 V / GND
4	S1 out

**SCTSD-L-xxxxO-xxFO**  
**SCTSD-L-xxxxx-xxxxx-15-KIT5**  
2 switching outputs, 1 analogue output  
M12x1; 5-pole

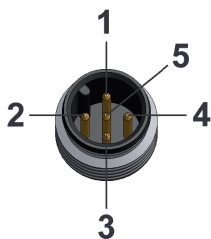

PIN	Assignment
1	V <sub>+</sub>
2	S2 out
3	0 V / GND
4	S1 out
5	Analogue out

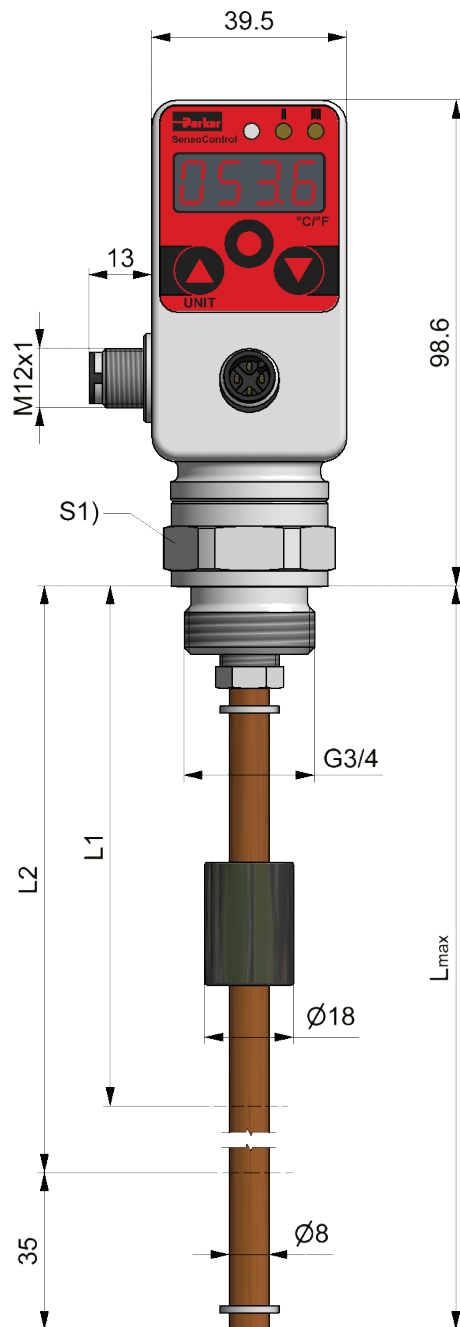

The Controller Family



# SCTSD-L combination switch

## Order code

### Standard version

2 level outputs, temperature display  
2 temperature switching outputs

### Advanced warning & shut-off

Warning = S1 out; falling open (L1)  
Cut-out = S2 out; falling open (L2)

#### Length (L1 / L2 mm)

60 / 90 mm	060	090
75 / 105 mm	075	105
90 / 120 mm	090	120
95 / 135 mm	095	135
110 / 150 mm	110	150
125 / 165 mm	125	165
135 / 165 mm	135	165
130 / 180 mm	130	180
145 / 195 mm	145	195
160 / 210 mm	160	210
140 / 220 mm	140	220
165 / 225 mm	165	225
180 / 240 mm	180	240
195 / 255 mm	195	255
210 / 270 mm	210	270
160 / 280 mm	160	280
225 / 285 mm	225	285
240 / 300 mm	240	300
245 / 315 mm	245	315
260 / 330 mm	260	330
275 / 345 mm	275	345
290 / 360 mm	290	360
315 / 385 mm	315	385
340 / 410 mm	340	410
355 / 435 mm	355	435
380 / 460 mm	380	460
420 / 500 mm	420	500
460 / 550 mm	460	550
510 / 600 mm	510	600
560 / 650 mm	560	650
600 / 700 mm	600	700
650 / 750 mm	650	750
700 / 800 mm	700	800
750 / 850 mm	750	850
800 / 900 mm	800	900
850 / 950 mm	850	950

### Shutdown min. / max.

Cut-out max = S1 out; rising open (L1)  
Cut-out min = S2 out; falling open (L2)

#### Length (L1 / L2 mm)

40 / 90 mm	040	090
50 / 120 mm	050	120
60 / 135 mm	060	135
90 / 165 mm	090	165
40 / 170 mm	040	170
60 / 250 mm	060	250
40 / 320 mm	040	320
60 / 370 mm	060	370
40 / 400 mm	040	400

### SCTSD-L-xxxFO-xxxFO

### Combination switch

SCTSD-L-xxxxx-xxxxx

### Combination switch Marine SCTSD-L-xxxxx-xxxxx-MA

(approved by DNV/GL/ABS)  
2 level outputs, temperature display  
2 temperature switching outputs

#### Length (L1 mm)

min. 40 mm / max. 950 mm

#### Version

Falling closed — FC  
Falling open — FO  
Rising closed — RC  
Rising open — RO

#### Length (L2 in mm)

min. 40 mm / max. 950 mm

#### Version

Falling closed — FC  
Falling open — FO  
Rising closed — RC  
Rising open — RO

### Combination switch

SCTSD-L-xxxxx-xxxxx-1x

### Combination switch Marine SCTSD-L-xxxxx-xxxxx-1x-MA

(approved by DNV/GL/ABS)  
2 level outputs, temperature display  
1 temperature-analogue output  
(0/4..20 mA)

#### Length (L1 mm)\*

min. 40 mm / max. 950 mm

#### Version

Falling closing — FC  
Falling open — FO  
Rising closing — RC  
Rising open — RO

#### Length (L2 in mm)\*

min. 40 mm / max. 950 mm

#### Version

Falling closing — FC  
Falling open — FO  
Rising closing — RC  
Rising open — RO

#### Plug-in connection

M12; 4-pole (1 temperature switching output) — 7  
M12; 5-pole (2 temperature switching outputs) — 5

\*Switching output 1 (L1) can be above or below switching output 2 (L2)

L1 and L2 are multiples of 10 mm

Smallest difference between L1 and L2 = 30 mm

# SCLSD LevelController

## Device features

- Proven measuring system
- Level display
- mm / inch / % display
- High and low display
- Analogue output
- Switching outputs
- No surge pipe necessary
- Replacement for several mechanical switches
- Pivoting

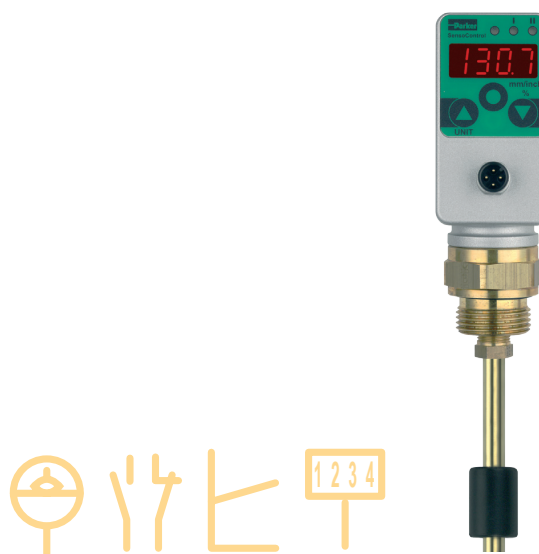

The LevelController combines the functions of a level switch, a level sensor and a level display.

- Level display (inspection glass)
- Switching outputs
- Analogue signal

The LevelController is ideal for the monitoring tank contents.

### Easy to use

The parameters are set using the keys or over a programming module.

### High functionality

Each switching output can be adjusted individually:

- NO/NC contact
- Upper and lower level switching point
- Delay times
- Hysteresis / window function
- Attenuation

The analogue output is individually adjustable:

- 0/4...20 mA switchable
- Upper level adjustable
- Lower level adjustable

### Reliable and safe

The position of the float is finely ( $\geq 5$  mm) and continuously recorded and shown in the display in mm or inch. Through this continuous recording, the danger of individual mechanical contacts "sticking" no longer exists. Therefore the operational reliability of the monitored plant is increased. Parameters can be password protected to avoid unauthorised changes.

### Everything at a glance

The display can be read from long distances. Using the selectable percent display the full level is uniformly displayed independent of the tank shape. An offset can also be entered (difference from the sensor to the tank bottom) to give a realistic indication of the level from the tank bottom.

Different uses can easily be implemented or corrected at a later date using the menu-driven level switching points. As the switching point no longer needs to be specified at the time of order, the versions of mechanical level switches required is reduced.

### Universal

Thanks to these easy switching functions (hysteresis and window functions, NC or NO functions), intelligent adjustments can be set which are normally not possible using a mechanical level switch. Therefore, many switches can be replaced with one controller. With the optional analogue output, the level and temperature can be monitored easily with a controller (e.g. for leakage monitoring).



# SCLSD LevelController

## Application example: Tank temperature monitoring

Since the conventional specifications for mechanical level switches (the mm data from the tank lid) are often used during project planning, these data are selected here for a practical example.

### Facility off

If the tank level falls below 310 mm (measured from the tank top / dry run) or climbs above 70 mm (measured from the tank top / overflow), switch off should occur. A protective wire-break mechanism should be considered to improve safety.

### Automatic tank filling

If the tank level falls below 240 mm (measured from the tank top), the tank should be automatically filled to 110 mm (measured from the tank top) with a pump.

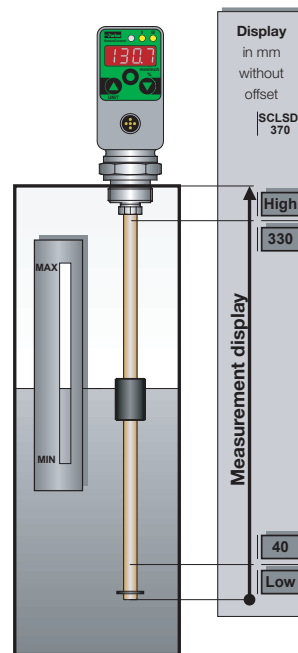

### Resulting switch value for a SCLSD-370 mm

Stop above:  
370 mm - 70 mm = 300 mm  
Stop below:  
370 mm - 310 mm = 60 mm  
Window function, NO contact

The output S1 is closed, if the level is between 300 and 60 mm.

Load stop:  
370 mm - 110 mm = 260 mm  
Load on:  
370 mm - 240 mm = 130 mm  
Hysteresis function, NC contact

If the level falls below 130 mm, the contact closes and opens again when 260 mm is exceeded.

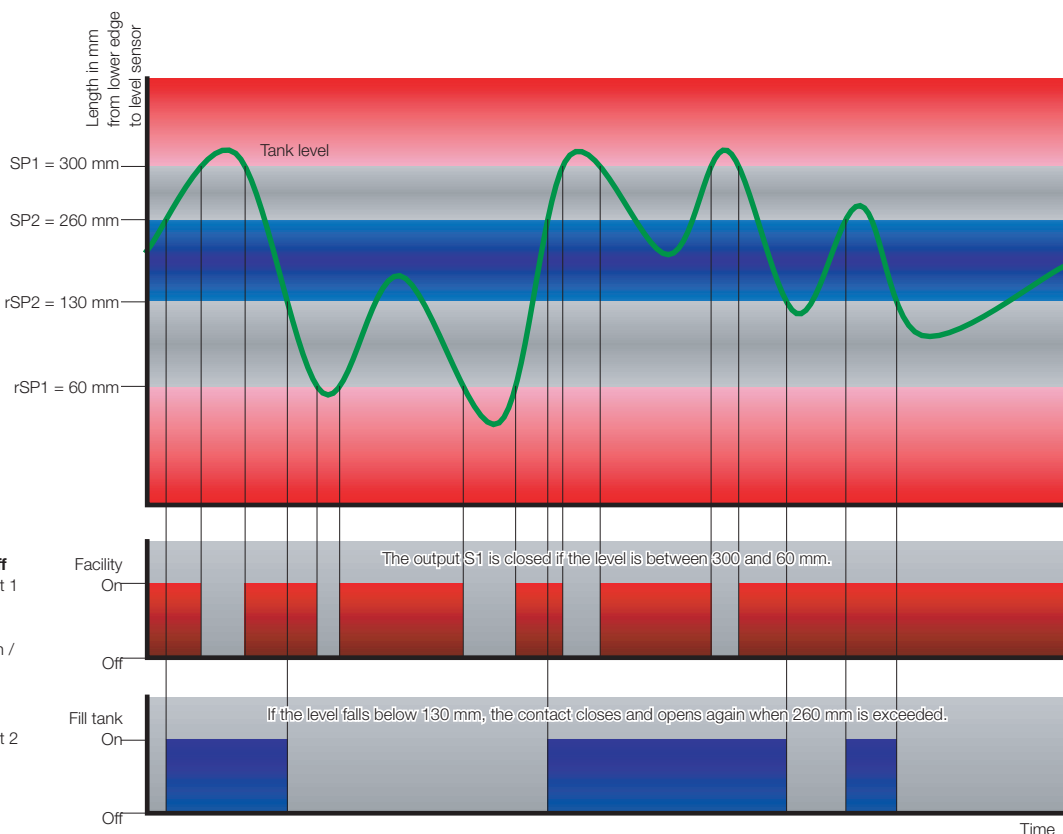

# SCLSD LevelController

## Device features

### Everything at a glance

- Sloped display
- Digital display
  - Large
  - Illuminated
- Display
  - mm, inch, or %
  - Actual level
  - High and low display
  - Switching points

### Rugged

- Metal housing
- Waterproof
- Excellent interference immunity
- Vibration proof
- Shock proof

### Variable installation

- Compact size
- 290° pivotable
- G3/4 BSPP
- Flange for DIN

### Programming module

- Adjustable with ControllerWIN Software

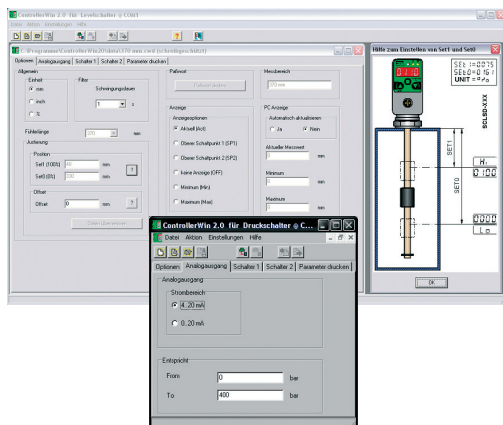

### Optical interface

- Switch status is shown

### Easy to use

- 3 large buttons
- Display of the unit

### Connect as required

- 2 switching outputs
- Analogue output
- 0...20 or 4...20 mA
- Freely programmable
- Scalable
- M12 connecting plugs



### No surge pipe necessary

- Electronic attenuation adjustable attenuation

### Proven measuring system

- High float dynamics
- Small design
- Universal usage

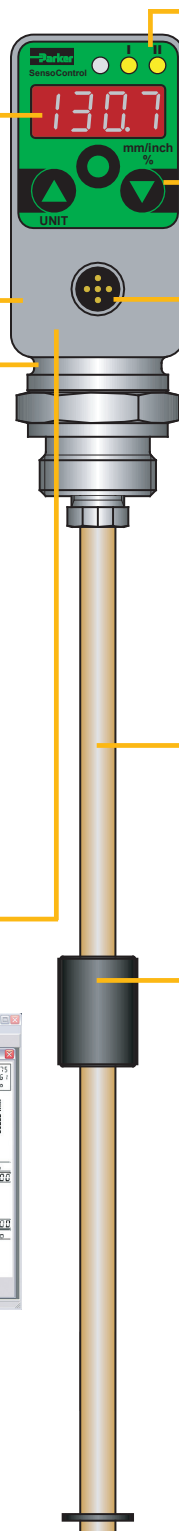

The Controller Family



# SCLSD LevelController

## Technical data

Input parameters	
Measuring component	Resistance reed chain with float
Connector thread	G3/4 BSPP; nickel-plated brass; ED soft seal NBR*
Parts in contact with substances	Brass; nickel-plated brass; NBR*
Temperature range of substance	-20...+85 °C
Output values	
Switching point accuracy	± 1 % FS at 25 °C
Display accuracy	± 1 % FS ± 1 Digit at 25 °C
Response speed	≤ 700 ms
Resolution	7.5 mm
Float	
Material	NBR
Dimensions	Ø 18 mm, Length 35 mm
Viscosity	Max. 250 cSt at 25 °C
Density	at least 0.750 g/cm <sup>3</sup>
Level rod	
Material	Stainless steel
Dimensions	Ø 8 mm
Operating pressure	1 bar
Electrical connection	
Supply voltage V <sub>+</sub>	15...30 VDC nominal 24 VDC; Protection class 3
Electrical connection	M12x1; 4-pole; 5-pole; with gold-plated contacts
Short-circuit protection	Yes
Protection against wrong insertion	Yes
Overload protection	Yes
Current consumption	< 100 mA

Housing	
	Adjustable direction to 290°C
Material	Die-cast zinc Z 410; painted
Foil material	Polyester
Display	4-digit 7-segment LED; red; digit height 9 mm
Protection degree	IP67 DIN EN 60529
Ambient conditions	
Ambient temperature range	-20...+85 °C
Storage temperature range	-40...+100 °C
EM compatibility	
Disturbance emissions	EN 61000-6-3
Resistance to interference	EN 61000-6-2
Outputs	
Switching outputs	Two MOSFET high-side switches (PNP)
Contact functions	NO / NC contact; window / hysteresis function freely adjustable
Switching voltage	V <sub>+</sub> - 1.5 VDC
Switching current max.	0.5 A per switch
Short-circuit current	2.4 A per switch
Analogue output	0/4...20 mA; programmable; freely scalable RL ≤ (power supply - 8 V) / 20 mA (≤ 500 Ω)

\* different sealing material (FKM, EPDM etc.) upon request

# SCLSD LevelController

## Display possibilities

Example of a percent display

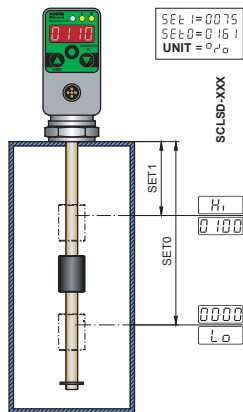

Example of a mm display

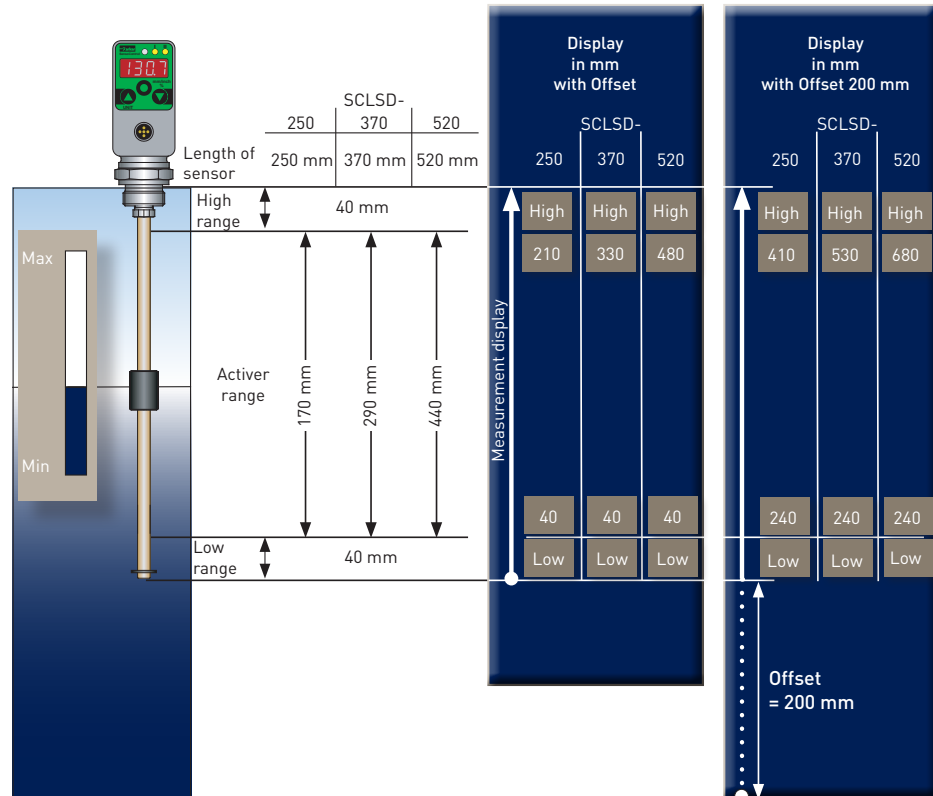

L1 Sensor length Measurement range	L2 active range	Display resolution Increment size	Incre- ment size	Lowest reset switch point RSP	Largest switch- ing value SP	Smallest adjustable difference between SP and RSP (SP-RSP)
250 mm	40...210 mm	1 mm	5 mm	40 mm	210 mm	5 mm
370 mm	40...330 mm	1 mm	5 mm	40 mm	330 mm	5 mm
520 mm	40...480 mm	1 mm	5 mm	40 mm	480 mm	5 mm
800 mm	40...760 mm	1 mm	10 mm	40 mm	760 mm	10 mm
1000 mm	40...960 mm	1 mm	10 mm	40 mm	960 mm	10 mm

## Pin assignment

### SCLSD-xxx-00-07

2 switching outputs; M12x1; 4-pole

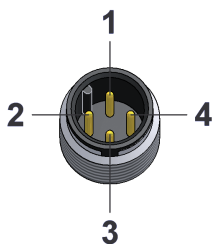

PIN	Assignment
1	V <sub>+</sub>
2	S2 out
3	0 V / GND
4	S1 out

### SCLSD-xxx-10-07

1 switching output, 1 analogue output, M12x1; 4-pole

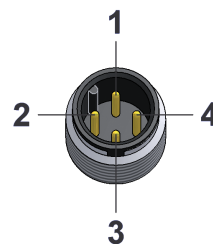

PIN	Assignment
1	V <sub>+</sub>
2	Analogue out
3	0 V / GND
4	S1 out



# SCLSD LevelController

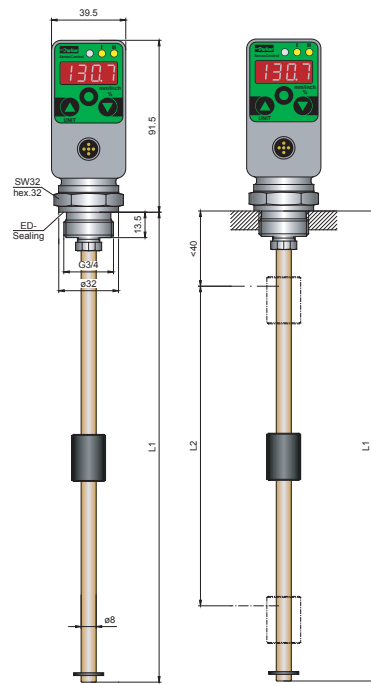

L1 = length of the sensor (mm)  
L2 = active range (mm)

## Order code

**SCLSD LevelController**  
**2 switching outputs;**  
**2 switching outputs Marine;**  
 (approved by DNV/GL/ABS)  
**no analogue output**  
 M12x1 connecting plug; 4-pole

SCLSD-xxx-00-07  
 SCLSD-xxx-00-07-MA

**1 switching output;**  
**1 switching output Marine;**  
 (approved by DNV/GL/ABS)  
**with analogue output**  
 M12x1 connecting plug; 4-pole

SCLSD-xxx-10-07  
 SCLSD-xxx-00-07-MA

**2 switching outputs;**  
**2 switching outputs Marine;**  
 (approved by DNV/GL/ABS)  
**with analogue output**  
 M12x1 connecting plug; 5-pole

SCLSD-xxx-10-05  
 SCLSD-xxx-10-05-MA

Length (Installation length L1 mm)

250 mm	250
370 mm	370
520 mm	520
800 mm	800
1000 mm	1000

## Accessories

**PC Programming Kit**

SCSD-PRG-KIT

**Flange adapter**

SCAF-3/4-90

6-hole connection DIN 24557, part 2

## Connection cable and single plug

**Connection cable, assembled**

SCK-400-xx-xx

(open cable end)

Cable length (m)

2 m	02
5 m	05
10 m	10

Connecting plug

M12 cable jack; straight	45
M12 cable jack; 90° angled	55

**Single connector**

M12 cable jack; straight

SCK-145

M12 cable jack; 90° angled

SCK-155

The Controller Family

**SCLSD-xxx-10-05**

2 switching outputs, 1 analogue output  
 M12x1; 5-pole

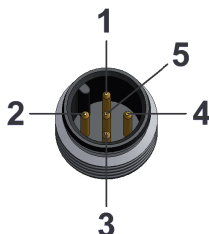

PIN	Assignment
1	V <sub>+</sub>
2	S2 out
3	0 V / GND
4	S1 out
5	Analogue out



# SCLTSD LevelTempController

## Device features

- Proven measuring system
- Pivoting
- Level display
- mm / inch / % display
- High and low display
- Analogue output
- Switching outputs
- Only one hole
- No surge pipe necessary
- Replacement for several mechanical switches



With the **LevelTempController**, you can set up and display the temperature and the level individually using a common platform. When monitoring the tank, this integration of level and temperature functionality opens up many possibilities.

The **LevelTempController** combines the functions of a level and temperature switch, a level and temperature sensor and a level and temperature indicator:

- Level and temperature display (thermometer / inspection glass)
- Switching outputs
- Analogue signal

### Level

The position of the float is finely ( $\geq 5$  mm) and continuously recorded and shown in the display in mm or inch. Because the level is continuously recorded, the danger of individual mechanical contacts "sticking" no longer exists. Therefore the operational reliability of the monitored plant is greatly increased.

Using the selectable percent display, the full level is uniformly displayed for the users, independent of the tank shape. An offset can also be entered (difference from the sensor to the tank bottom) to give a realistic indication of the level from the tank bottom.

Different uses can easily be implemented or corrected at a later date using the menu-driven level switching points.

As the switching point no longer needs to be specified at the time of order, the versions of mechanical level switches required is reduced.

### Temperature

The temperature in the substance is continuously recorded and displayed. The switching outputs can be individually set up just like the LevelController. Naturally all the convenient switching functions are available: window, hysteresis function and open / close as well as an analogue output for temperature.

### Reliable and safe

Parameters can be password protected to avoid unauthorised changes.

### Universal

Thanks to these easy switching functions (hysteresis and window functions, NC or NO functions), intelligent adjustments can be set on the LevelTempController which are normally not possible using a mechanical level switch. Therefore, many switches can be replaced with one controller. With the optional analogue outputs, the level and temperature can be monitored easily with a controller.

Level: e.g. for leakage monitoring

Temperature: e.g. coolers, heating, alarm, shutdown



# SCLTSD LevelTempController

## Application examples

### SCLSD



Application example  
Refer to page 84

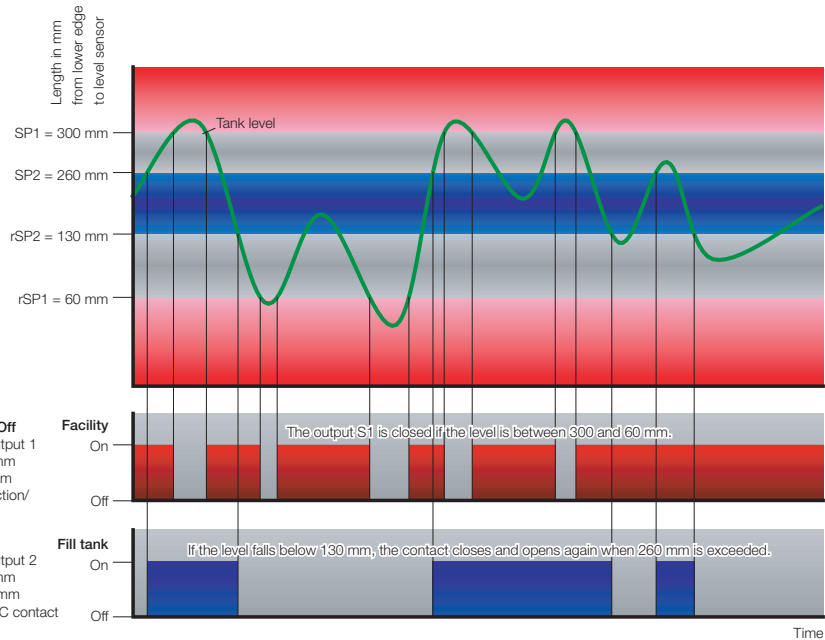

### SCTSD



Application example  
Refer to page 68

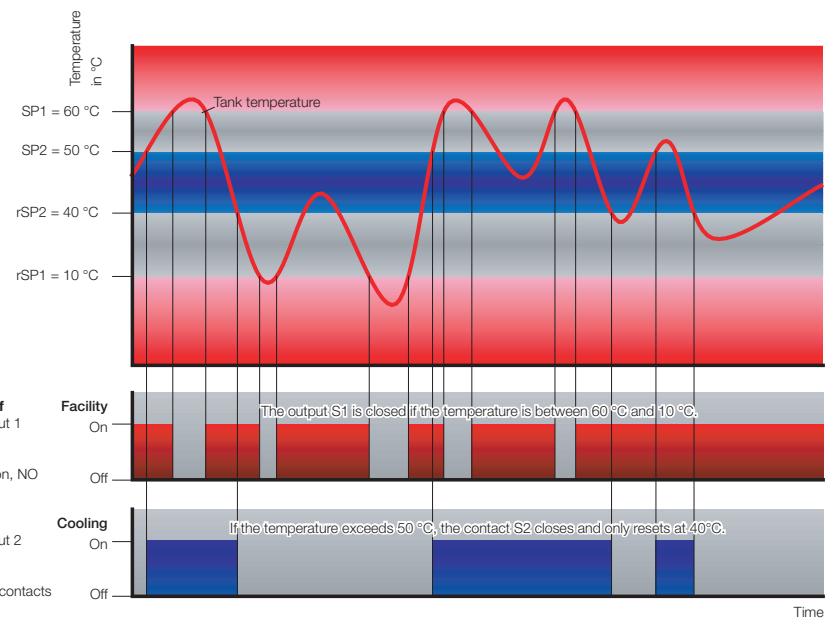

# SCLTSD LevelTempController

## Device features

### Everything at a glance

- Sloped display
- Digital display
  - Large
  - Illuminated
  - Switching points
- Display level
  - mm, inch, or %
  - Actual level
  - High and low display
- Temperature display
  - °C, °F
  - Current temperature

### Rugged

- Metal housing
- Waterproof
- Excellent interference immunity
- Vibration proof
- Shock proof

### Variable installation

- A coupling hole
- Compact size
- 290° pivotable
- G3/4 BSPP
- DIN flange

### Programming module

- Adjustable with ControllerWIN Software

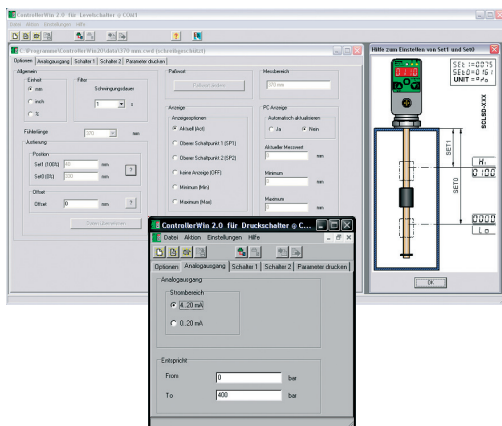

### Optical interface

- Switch status is shown

### Easy to use

- 3 large buttons
- Display of the unit

### Connect as required

- 2 switching outputs
- Analogue output
- 0...20 or 4...20 mA
- Freely programmable
- Scalable
- M12 connecting plugs



### Twin concept

- 2 in 1

### No surge pipe necessary

- Electronic attenuation adjustable attenuation

### Level

- Proven measuring system
- High float dynamics
- Small design
- Universal usage

### Temperature sensor

- Integrated in the rod end

The Controller Family



# SCLTSD LevelTempController

## Technical data

Electrical connection	
Supply voltage $V_+$	15...30 VDC nominal 24 VDC; Protection class 3
Electrical connection	M12x1; 4-pole; 5-pole; with gold-plated contacts
Short-circuit protection	Yes
Protection against wrong insertion	Yes
Overload protection	Yes
Current consumption	< 100 mA
Housing	
	Adjustable direction to 290°C
Material	Die-cast zinc Z 410; painted
Foil material	Polyester
Display	4-digit 7-segment LED; red; digit height 9 mm
Protection degree	IP67 DIN EN 60529
Ambient conditions	
Ambient temperature range	-20...+85 °C
Temperature range of substance	≤ 80 °C
Storage temperature range	-40...+100 °C
EM compatibility	
Disturbance emissions	EN 61000-6-3
Resistance to interference	EN 61000-6-2
Outputs	
Switching outputs	Two MOSFET high-side switches (PNP)
Contact functions	NO / NC contact; window / hysteresis function freely adjustable
Switching voltage	$V_+ - 1.5$ VDC
Switching current max.	0.5 A per switch
Short-circuit current	2.4 A per switch
Analogue output	0/4 to 20 mA; programmable; freely scalable $RL \leq (V_+ - 8 V) / 20 \text{ mA} (\leq 500 \Omega)$

## Level

Input parameters	
Measuring component	Resistance reed chain with float
Connector thread	G3/4 BSPP; nickel-plated brass; ED soft seal NBR*
Parts in contact with substances	Brass; nickel-plated brass; NBR*
Temperature range of substance	≤ 80 °C
Output values	
Switching point accuracy	± 1 % FS at 25 °C
Display accuracy	± 1 % FS ± 1 Digit at 25 °C
Response speed	≤ 700 ms
Resolution	7.5 mm
Float	
Material	NBR
Dimensions	Ø 18 mm, Length 35 mm
Viscosity	Max. 250 cSt at 25 °C
Density	at least 0.750 g/cm <sup>3</sup>
Level rod	
Material	Stainless steel
Dimensions	Ø 8 mm
Operating pressure	1 bar

## Temperature

Output values	
Switching point accuracy	± 0.35 % FS at 25 °C
Display accuracy	± 0.35 % FS ± 1 Digit at 25 °C
Response speed	≤ 300 ms
Analogue output	0/4...20 mA; programmable; freely scalable; 4...20 mA = -40...125 °C

\* different sealing material (FKM, EPDM etc.) upon request

# SCLTSD LevelTempController

## Display possibilities

Example of a percent display

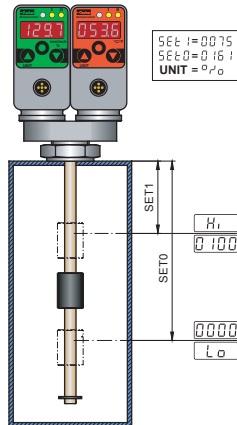

Example of a mm display

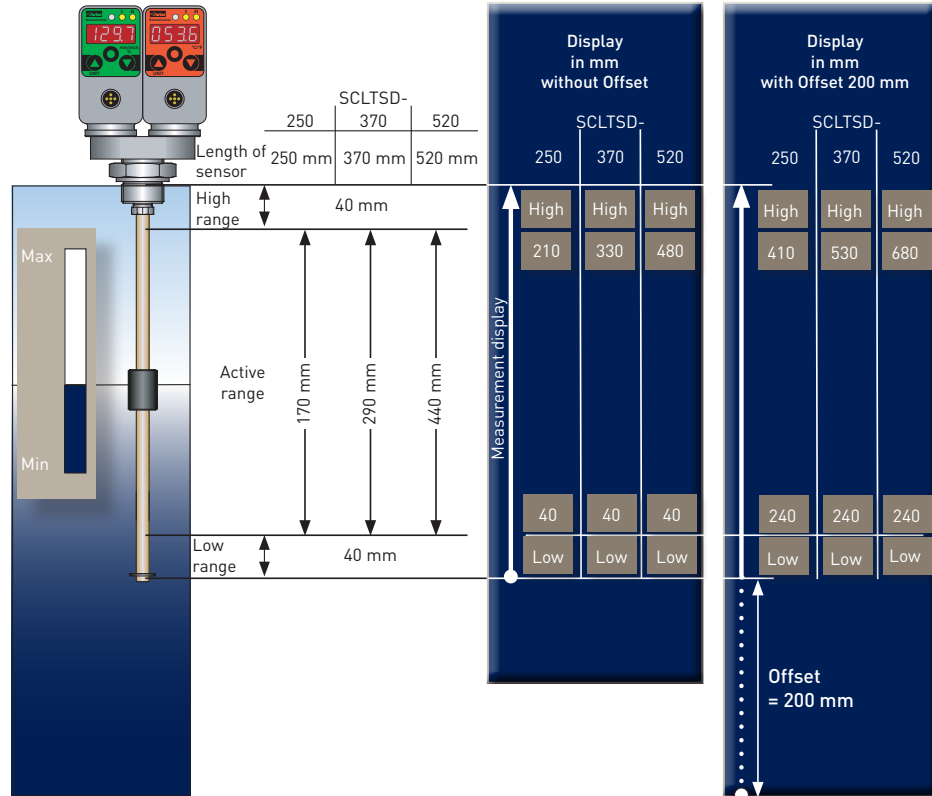

L1 Sensor length Measurement range	L2 active range	Display resolution Increment size	Increment size	Lowest reset switch point RSP	Largest switching value SP	Smallest adjustable difference between SP and RSP (SP-RSP)
250 mm	40...210 mm	1 mm	5 mm	40 mm	210 mm	5 mm
370 mm	40...330 mm	1 mm	5 mm	40 mm	330 mm	5 mm
520 mm	40...480 mm	1 mm	5 mm	40 mm	480 mm	5 mm
800 mm	40...760 mm	1 mm	10 mm	40 mm	760 mm	10 mm
1000 mm	40...960 mm	1 mm	10 mm	40 mm	960 mm	10 mm

## Pin assignment

SCLTSD-xxx-00-07 for temperature and level  
2 switching outputs; M12x1; 4-pole

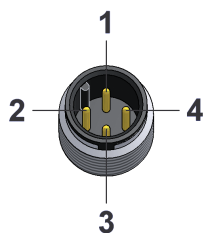

PIN	Assignment
1	V <sub>+</sub>
2	S2 out
3	0 V / GND
4	S1 out

SCLTSD-xxx-10-07 for temperature and level  
1 switching output, 1 analogue output, M12x1; 4-pole

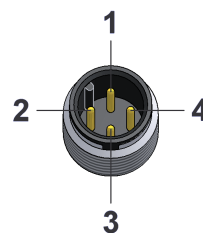

PIN	Assignment
1	V <sub>+</sub>
2	Analogue out
3	0 V / GND
4	S1 out



# SCLTSD LevelTempController

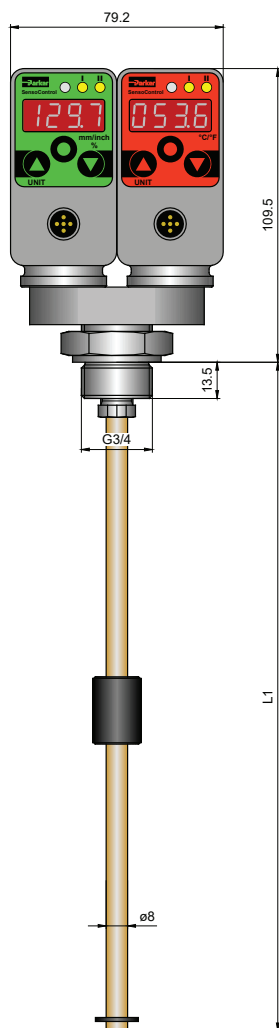

L1 = length of the sensor (mm)  
L2 = active range (mm)

## Order code

### SCLTSD LevelTempController

**2 switching outputs;**  
**2 switching outputs Marine;**  
(approved by DNV/GL/ABS)  
**no analogue output**  
M12x1 connecting plug; 4-pole

SCLTSD-xxx-00-07  
SCLTSD-xxx-00-07-MA

**1 switching output;**  
**1 switching output Marine;**  
(approved by DNV/GL/ABS)  
**with analogue output**  
M12x1 connecting plug; 4-pole

SCLTSD-xxx-10-07  
SCLTSD-xxx-10-07-MA

**2 switching output;**  
**2 switching output Marine**  
(approved by DNV/GL/ABS)  
**with analogue output**  
M12x1 connecting plug; 5-pole

SCLTSD-xxx-10-05  
SCLTSD-xxx-10-05-MA

### Installation length (L1 mm)

250 mm	250
370 mm	370
520 mm	520
800 mm	800
1000 mm	1000

## Accessories

### PC Programming Kit

SCSD-PRG-KIT

### Flange adapter

SCAF-3/4-90

6-hole connection DIN 24557, part 2

## Connection cable and single plug

### Connection cable, assembled

SCK-400-xx-xx

(open cable end)

### Cable length (m)

2 m	02
5 m	05
10 m	10

### Connecting plug

M12 cable jack; straight	45
M12 cable jack; 90° angled	55

### Single connector

M12 cable jack; straight	SCK-145
M12 cable jack; 90° angled	SCK-155

The Controller Family

### SCLTSD-xxx-10-05 for temperature and level

2 switching outputs, 1 analogue output; M12x1; 5-pole

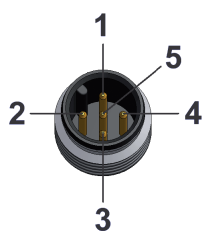

PIN	Assignment
1	V <sub>+</sub>
2	S2 out
3	0 V / GND
4	S1 out
5	Analogue out



# SCOTC OilTankController

## Device features

- Proven measuring system
- Level and temperature display
- mm / inch / % display
- High and low display
- Only one hole
- Continuous level measurement
- Connection
  - Filling coupling
  - Air filter
  - Low pressure
- No surge pipe necessary

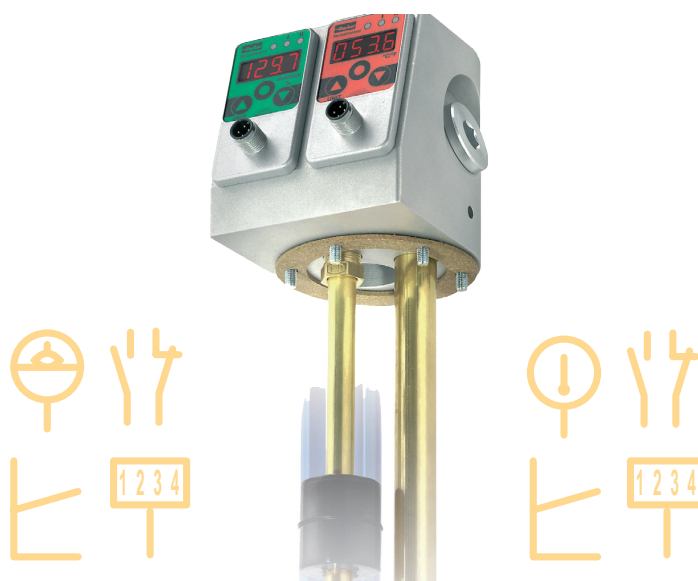

In addition to the **LevelTempController**, the **OilTankController** also offers standardised connections for an air filter and a fill coupling.

When monitoring the tank for series use, this integration of level and temperature functionality together with air filter and fill adapter port opens up many possibilities. An additional connecting hole is required for the four functions.

**The OilTankController combines the functions of a level and temperature switch, a level and temperature sensor and a level and temperature display:**

- Level and temperature display (thermometer / inspection glass)
- Switching outputs
- Analogue signal

### Level

The position of the float is finely ( $\geq 5$  mm) and continuously recorded and shown in the display in mm or inch. Because the level is continuously recorded, the danger of individual mechanical contacts "sticking" no longer exists. Therefore the operational reliability of the monitored plant is greatly increased.

Using the selectable percent display, the full level is uniformly displayed for the users, independent of the tank shape. An offset can also be entered (difference from the sensor to the tank bottom) to give a realistic indication of the level from the tank bottom.

Different uses can easily be implemented or corrected at a later date using the menu-driven level switching points.

As the switching point no longer needs to be specified at the time of order, the versions of mechanical level switches required is reduced.

### Temperature

The temperature in the substance is continuously recorded and displayed. The switching outputs can be individually set up just like the LevelController. Naturally all the convenient switching functions are available: window, hysteresis function and open/close as well as an analogue output for temperature.

### Reliable and safe

Parameters can be password protected to avoid unauthorised changes.

### Universal

In combination with the comfortable switch functions like hysteresis and window function, open/close contact functions **LevelTempController** intelligent settings can be made which are not possible with a mechanical level/temperature switch. Therefore, many switches can be replaced with one controller. With the optional analogue outputs, the level and temperature can be monitored easily with a controller.

Level: e.g. for leakage monitoring

Temperature: e.g. coolers, heating, alarm, shutdown

# SCOTC OilTankController

## Application examples

### SCLSD



Application example  
Refer to page 84

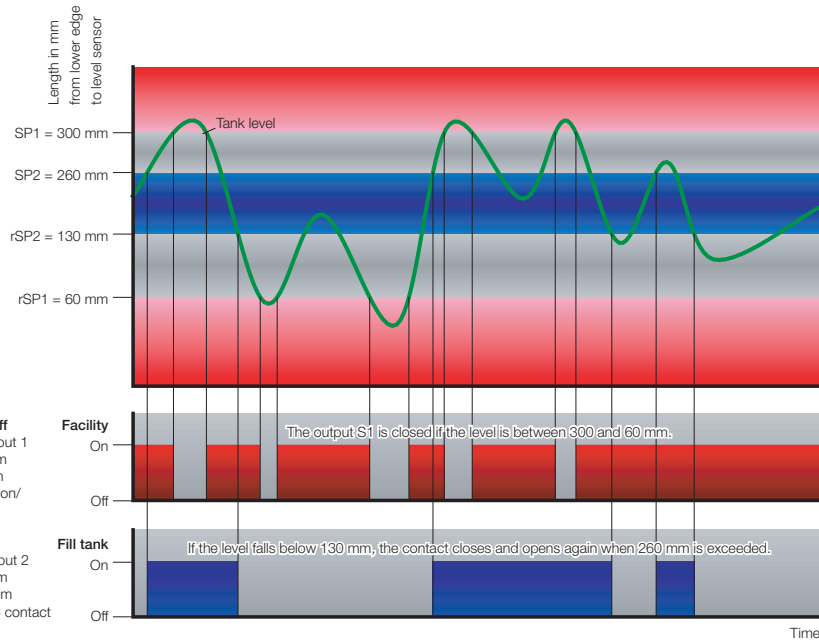

### SCTSD

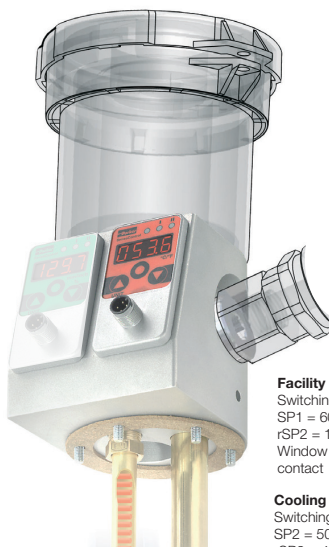

Application example  
Refer to page 68

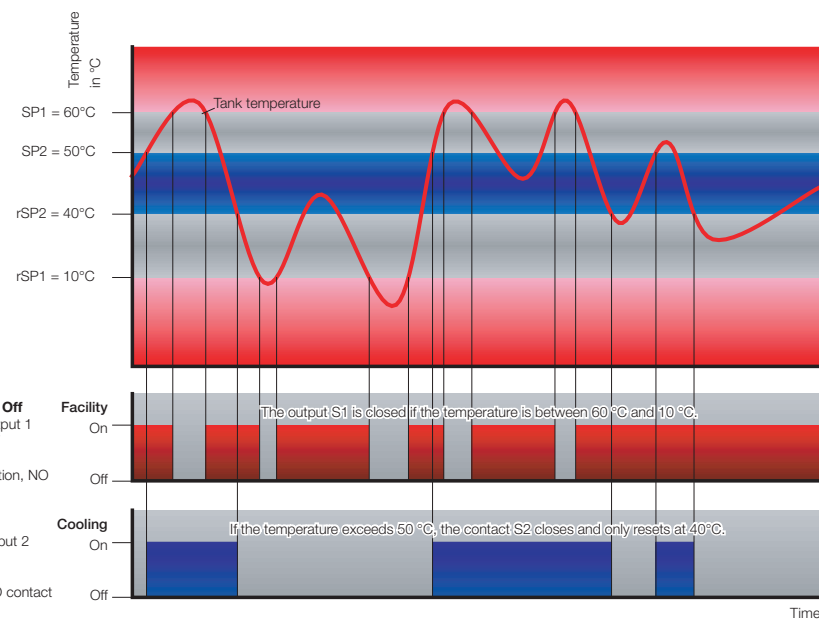

The Controller Family



# SCOTC OilTankController

## Device features

### Getting to the point

- Compact construction (4 in 1)
- Easy adjustment of the switching points using the menu
- Analogue output
- Safety control
- Cost savings in the logistics, assembly and maintenance

### Level and temperature

- Display
- Adjustable switching output
- Analogue output

### The extended version

with safety control

- Additional fixed switching contacts
- Level min/max
- Temperature too high

### Real fill level

- The level controller continuously measures the position of the float and continuously shows the position in the display.
- Up to 1000 mm

### No surge pipe necessary

- Electronic attenuation
- adjustable attenuation

### Temperature sensor

- Integrated in the rod end

### 6-hole standard for

- Ventilation filter\* (DIN 24557, part 2)

### G3/4 BSPP for

- Filling coupling\*

### G1/8 BSPP for

- Low pressure switch\*
- Clogging indicator\*

### 6-hole standard for

- Tank connection (DIN 24557, part 2)

### Filling tube

### No whirl-up

- Whirl-up protection

### Programming module

- Adjustable with ControllerWIN Software

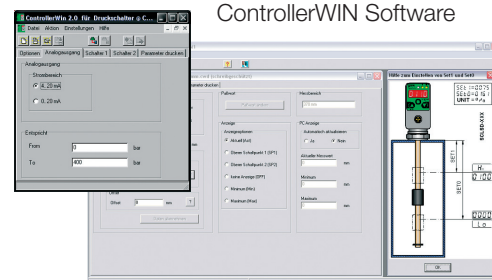

\* Venting filter, filling coupling, low pressure switch and clogging indicator are not included in the delivery.



# SCOTC OilTankController

## Technical data

SCOTC	250	370	520	800	1000
Tank installation length	250 mm	370 mm	520 mm	800 mm	1000 mm
Adjustment range	40...210 mm	40...330 mm	40...480 mm	40...760 mm	40...960 mm

Electrical connection	
Supply voltage $V_+$	15 to 30 VDC nominal 24 VDC; Protection class 3
Electrical connection	M12x1; 4-pole; 5-pole; with gold-plated contacts
Short-circuit protection	Yes
Protection against wrong insertion	Yes
Overload protection	Yes
Current consumption	< 100 mA
Housing	
Material	Die-cast zinc Z 410; painted Aluminium
Foil material	Polyester
Display	4-digit 7-segment LED; red; digit height 9 mm
Protection degree	IP67 DIN EN 60529
Ambient conditions	
Ambient temperature range	-20...+80 °C
Temperature range of substance	≤ 80 °C
Storage temperature range	-40...+100 °C
Sampling period	300 ms
Display refresh	1 s
EM compatibility	
Disturbance emissions	EN 61000-6-3
Resistance to interference	EN 61000-6-2
Outputs	
Switching outputs	Two MOSFET high-side switches (PNP)
Contact functions	NO / NC contact; window / hysteresis function freely adjustable
Switching voltage	$V_+$ -1.5 VDC
Switching current max.	0.5 A per switch
Short-circuit current	2.4 A per switch
Optional analogue output	
Measuring range	0/4...20 mA; programmable
Response speed (0 to 95%)	≤ 300 ms
Error	± 1 % FS
Load	≤ 500 Ω from $V_b$ > 18 VDC

Level	
Input variables	
Measuring component	Reed chain resistance
Connector thread	6 hole standard- DIN 24557, part 2
Output variables	
Switching point accuracy	± 1 % FS at 25 °C
Display accuracy	± 1 % FS ± 1 Digit at 25 °C
Response speed	≤ 700 ms
Resolution	5 mm...520 mm; 10 mm > 520 mm
Float	
Material	Polypropylene
Dimensions	Ø 35 mm, Length 40 mm
Level rod	
Material	Brass
Dimensions	Ø 12 mm
Operating pressure	1 bar max.
Optional Lo-Hi contact (S3 out)	
Alarm contact	In series switched Lo and Hi NC contact
Maximum load current	0.7 A
Temperature	
Input variables	
Sensor element	PT1000
Filling tube	Ø 18x1 mm
Response time	$\tau_{0.9} = 60$ s
Output variables	
Switching point accuracy	± 0.5 % FS at 25 °C
Display accuracy	± 0.5 % FS ± 1 Digit at 25 °C
Response speed	≤ 300 ms
Analogue output	0/4...20 mA; programmable; freely scalable; 4...20 mA = -40...125 °C
Optional temperature switch (S3 out)	
Alarm contact with > 65 °C	Open contact
Maximum charging current	0.7 A

# SCOTC OilTankController

## Pin assignment

### Without safety-control-output

#### SCOTC-xxxx-00-07

for temperature and level

2 switching outputs

M12x1; 4-pole

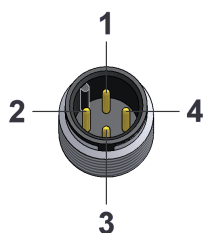

PIN	Assignment
1	V <sub>+</sub>
2	S2 out
3	0 V / GND
4	S1 out

#### SCOTC-xxxx-10-07

for temperature and level

1 switching outputs, 1 analogue output

M12x1; 5-pole

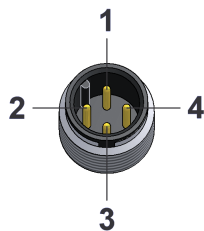

PIN	Assignment
1	V <sub>+</sub>
2	Analogue out
3	0 V / GND
4	S1 out

#### SCOTC-xxxx-10-05

for temperature and level

2 switching outputs, 1 analogue output

M12x1; 5-pole

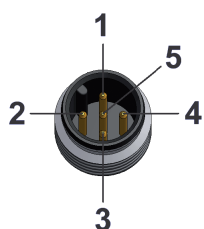

PIN	Assignment
1	V <sub>+</sub>
2	S2 out
3	0 V / GND
4	S1 out
5	Analogue out

### With safety-control-output

#### SCOTC-xxxx-00-05

Level:

Two variable switching outputs,

One fixed safety-control-output level min/max;

M12x1; 5-pole

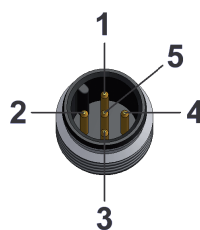

PIN	Assignment
1	V <sub>+</sub>
2	S2 out
3	0 V / GND
4	S1 out
5	S3 out (L-Low / L-High)

#### SCOTC-xxxx-00-05

Temperature:

Two variable switching outputs,

One fixed safety-control-output temperature max. 65 °C

M12x1; 5-pole

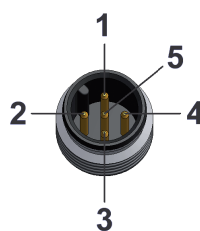

PIN	Assignment
1	V <sub>+</sub>
2	S2 out
3	0 V / GND
4	S1 out
5	S3 out (T-High)

L1 Sensor length Measurement range	L2 active range	Display resolu- tion increment size	Increment size	Lowest reset switch point RSP	Largest switch- ing value SP	Smallest adjustable difference between SP and RSP (SP-RSP)
250 mm	170 mm	1 mm	5 mm	40	210	5 mm
370 mm	290 mm	1 mm	5 mm	40	330	5 mm
520 mm	440 mm	1 mm	5 mm	40	480	5 mm
800 mm	720 mm	1 mm	10 mm	40	760	10 mm
1000 mm	920 mm	1 mm	10 mm	40	960	10 mm



# SCOTC OilTankController

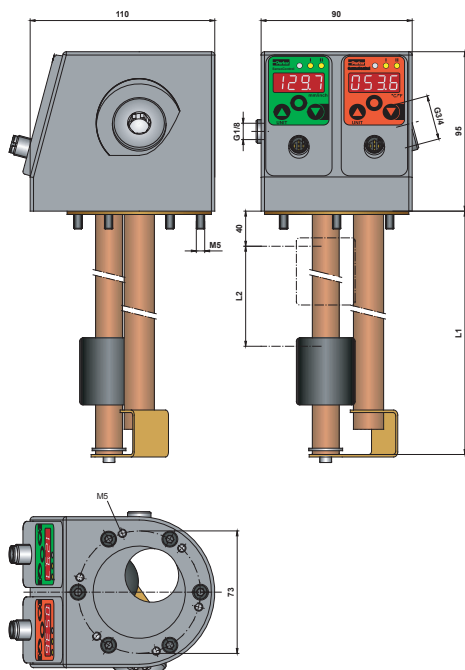

L1 = length of the sensor (mm)  
L2 = active range (mm)

## Order code

### SCOTC OilTankController \*

**2 switching outputs; no analogue output** SCOTC-xxxx-00-07  
M12x1 connecting plug; 4-pole

**2 switching outputs; with analogue output** SCOTC-xxxx-10-07  
M12x1 connecting plug; 4-pole

**1 switching output; with analogue output** SCOTC-xxxx-10-05  
M12x1 connecting plug; 5-pole

**3 switching outputs; no analogue output** SCOTC-xxxx-00-05  
M12x1 connecting plug; 5-pole  
with safety control

### Length (Installation length L1 mm)

250 mm	250
370 mm	370
520 mm	520
800 mm	800
1000 mm	1000

## Accessories

**PC Programming Kit**

SCSD-PRG-KIT

## Connection cable and single plug

### Connection cable, assembled

SCK-400-xx-xx

(open cable end)

### Cable length (m)

2 m	02
5 m	05
10 m	10

### Connecting plug

M12 cable jack; straight	45
M12 cable jack; 90° angled	55

### Single connector

M12 cable jack; straight	SCK-145
M12 cable jack; 90° angled	SCK-155

\* Venting filter, filling coupling, low pressure switch and clogging indicator are not included in the delivery.

# SCK cable

## Device features

- One cable for all
- Compact size
- Interference-free
- Compatible to:
  - Sensors
  - Controllers
- M12 plug
- DIN EN 175301 (Device plug)
- Available in a variety of lengths



Accessories

The **SensoControl**® cable was designed for use with the industrial sensors and switches.

Thus the M12 cable and M12 plug are

- Compact
- Shielded
- Five-pole

### 5-pole version

The 5-pole cable is suitable for both 4-pole and 5-pole connections. The sensor variants with a 4-pole connector are fully compatible with the 5-pole cable.

So despite different pin counts on the pressures switch (Controller Family SCxSD and SCOTC) and sensors, it is always possible to use just one cable version (5-pole) regardless of the plug version.

The SCK-400-xxx-x5 cables fit to all components in this catalogue using M12 connectors.

### Shielding

Shielding protects against interference and ensures improved operational safety.

- Higher EMC protection

## Pin assignment

### SCK-400-xx-x5

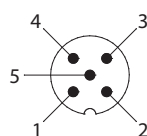

PIN			
1	bn	brown	braun
2	wh	white	weiß
3	bu	blue	blau
4	bk	black	schwarz
5	gy	grey	grau

### SCK-400-xx-56



PIN			
1	ye	yellow	gelb
2	gn	green	grün
3	bn	brown	braun

# SCK cable

Accessories

## Connection cable

SCK-400-xx-45

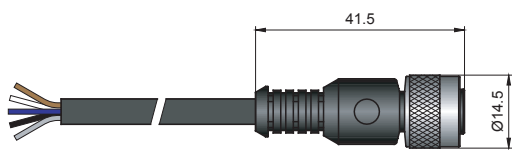

SCK-400-xx-55

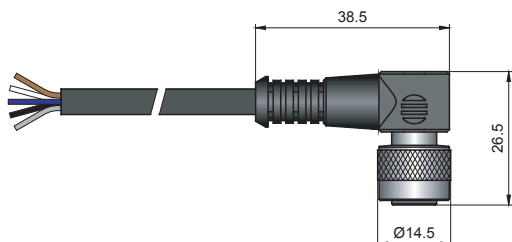

SCK-400-xx-56

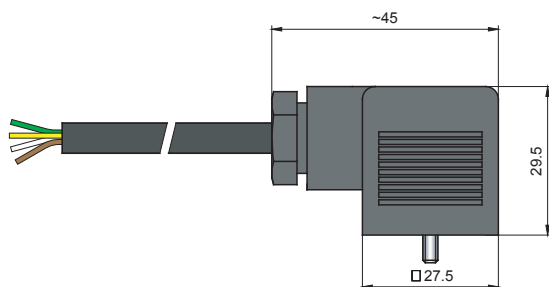

## Single connector

SCK-006 (Device plug)

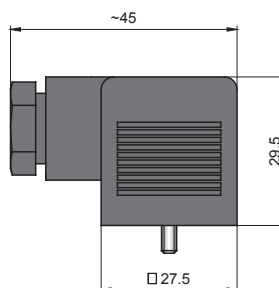

## Single connector

SCK-145

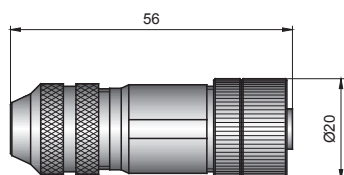

SCK-155

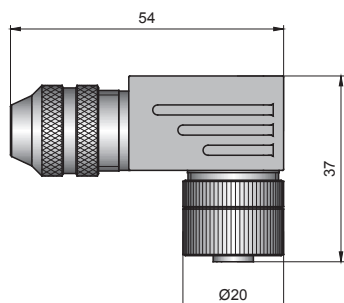

## Connection cable and single plug

### Connection cable, assembled

(open cable end)

#### Cable length (m)

2 m	02
5 m	05
10 m	10

#### Connecting plug

M12 cable jack; straight	45
M12 cable jack; 90° angled	55
Cable socket DIN EN 175301-803 Form A (old DIN 43650)	56

### Single connector

M12 cable jack; straight	SCK-145
M12 cable jack; 90° angled	SCK-155
Cable socket DIN EN 175301-803 Form A (old DIN 43650)	SCK-006



# SCA adapter

## SCA-1/4 reduction adapter

The SCA-1/4 provides compatibility for earlier sensor versions with the hydraulic connection M22x1.5 or G1/2 BSPP.

- When replacing earlier versions

This allows facilities to be updated without major planning overhead.

SCA-1/4-M22x1.5-ED  
SCA-1/4-ED-1/2-ED

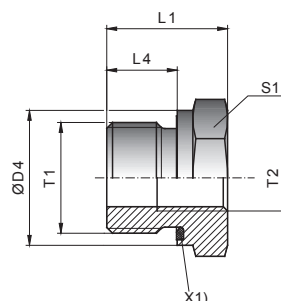

X1) EOLASTIC-seal

	T1	T2	ØD4	L1	L4	S1	Weight (g/1 St)	PN (bar) <sup>1)</sup>	DF **
<b>SCA-1/4-M22x1.5-ED</b>	M22x1.5	G1/4 BSPP	27	24	14	27	56	400	4
<b>SCA-1/4ED1/2-ED</b>	G1/2 BSPP	G1/4 BSPP	27	24	14	27	56	400	4

## SCA-1/4 attenuation adapter

System-related pressure spikes are reduced with the SCA-1/4-EDX-1/4-D.

- Attenuation for pressure peaks

The G1/2 BSPP version ensures compatibility for earlier sensor versions to the G1/2 BSPP hydraulic connection.

- When replacing earlier versions

SCA-1/4-EDX-1/4-D

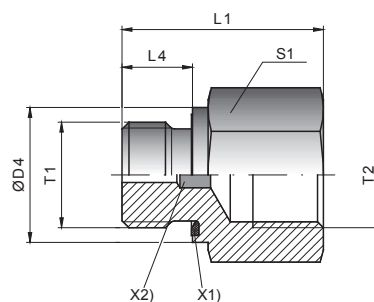

X1) EOLASTIC-seal

	T1	T2	ØD4	L1	L4	S1	Weight (g/1 St)	PN (bar) <sup>1)</sup>	DF **
<b>SCA-1/4EDX1/4-D</b>	G1/4A BSPP	G1/4 BSPP	19	34	12	22	61	630	3.5

# SCA adapter

Accessories

## SCPSD flange adapter SCAF-1/4-40 for mechanical pressure switch

When replacing existing mechanical pressures switches with 40x40mm flange connections SCAF-1/4-40

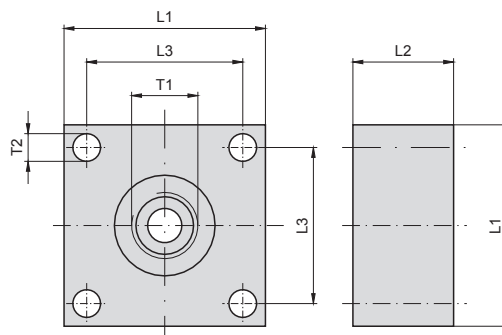

**SCAF-1/4-40**  
for mechanical pressure switch

**SCAF-1/4-40**

T1	T2	L1	L2	L3	Weight (g/1 St)	PN (bar) <sup>1)</sup> Alu	DF **
G1/4 BSPP	5.5	40	20	31	15	400	4

## SCLSD/SCLTSD flange adapter SCAF-3/4-90 6-hole connection DIN 24557, part 2

For LevelController and LevelTemp Controller (SCLSD and SCLTSD), a compatibility to the tank connections 6-hole DIN 24557, part 2, is ensured. SCAF-3/4-90

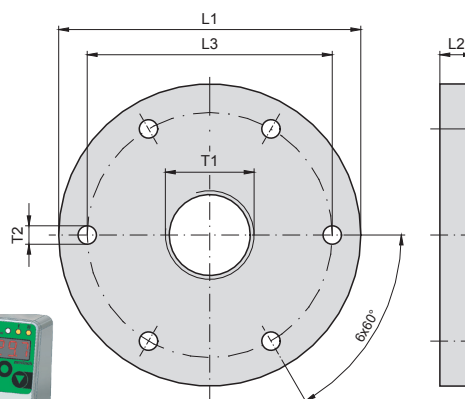

**SCAF-3/4-90**  
6-hole connection DIN 24557, part 2

**SCAF-3/4-90**

T1	T2	L1	L2	L3	Weight (g/1 St)	Material
G3/4 BSPP	5.5	90	10	73	520	Nickel-plated brass

\*\* DF = Design Factor (safety factor)



# ControllerWIN software

## Device features

- Suitable for the Controller Family
- Simple adjustment of all parameters
- Saving of the parameters
- Adjustment with PC/laptop
  - at the workbench
  - at the desk
  - in the plant

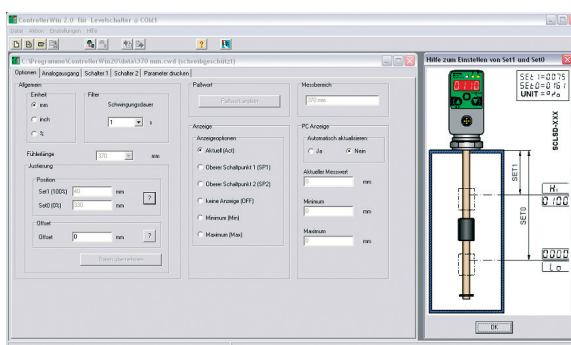

The ControllerWIN software allows the adjustment and saving of all parameters, including:

- Switching points
- NO / NC contact function
- Window / hysteresis
- Scaling of the analogue output
- Passwords

From the Controller Family product series:

- SCPSD
- SCTSD
- SCLSD
- SCLTSD
- SCOTC

## Function

A no-contact infra-red interface is used to compare the data with the corresponding functional controller. This can take place directly in the facility or externally using a power supply unit (not included in the delivery).

- It is not necessary to disconnect the power supply or pull the cable out (operations are not interrupted).

A programming adapter is connected to the corresponding controller and the data is transmitted to a PC.

The SCSD-PRG\_KIT programming kit includes all components (adapter, software and power supply) required for adjusting the controller with the PC or laptop:

- At the workbench
- At the desk
- In the plant

## Application

- Saving and logging the adjusted values
- Programming multiple controllers
- Easy exchange of existing controllers

The programming kit is the ideal solution in each of these cases.

# ControllerWIN software

## Technical data

### System requirements

Operating system	PC / laptop connection	Controller connection
WIN 98/2000/ME/NT/XP	RS232 (USB using conventional adapter)	Parker infra-red interface SCxSD/SCOTC

Accessories

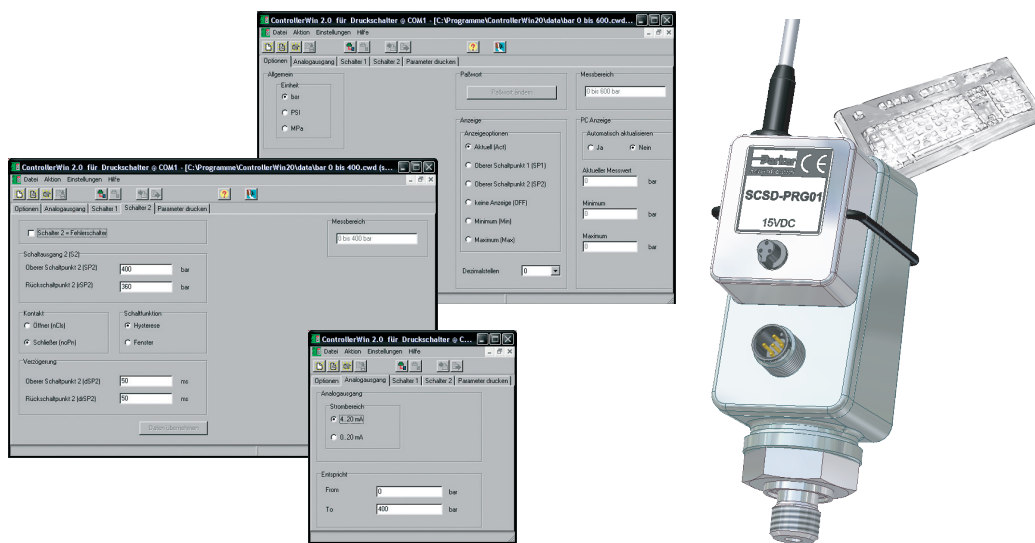

### Accessories for:

PressureController	TemperatureController	LevelController	LevelTempController	OilTankController
Pressure display and monitoring	Temperature display and monitoring	Level indication and monitoring	Level and temperature display and monitoring	

### Order code

PC Programming KIT

SCSD-PRG-KIT



# Installation and safety instructions

**CE** The CE mark indicates a high-quality device that complies with the European directive 89/336/EEG and EMVG.

We confirm that these products comply with the following standards:

## EMC

- Electromagnetic emission: EN 61000-6-3
- Electromagnetic immunity: EN 61000-6-2

## Important

- Electromagnetic disturbances can affect the desired signal.
- Apply all general EMC strategies when planning facilities and machines.
- We recommend using shielded cables (SCK-400-xx-x5) in order to achieve better EMC immunity.
- Make sure you route analogue and data cables so that there is a sufficient gap between them.
- An effective earthing strategy will help you to avoid measuring errors.

Always connect metal housings with the reference ground. The PE protective earth should have a low-ohm connection. According to VDE 0701, the PE resistance must be measured.

## Power feed voltage



Each sensor series specifies the recommended feed voltage to be used when operating the standard sensor. We recommend using a low-noise, high-quality, constant voltage source. Certain specifications (such as sensitivity and thermal sensitivity shift) may change when other power feeds are used. Each sensor is trimmed to its peak performance. The sensor's performance may change when other power feed types are used. Make sure you comply with the polarity and earthing regulations.

Improperly connected feed wires can damage sensors and amplifiers!

If one pole of the sensor feed is automatically earthed via the sensor's processing system, then you should avoid an additional earth on the sensor signal wire. This would cause the sensor to short circuit and damage the sensor.

Do not apply feed-in voltage to the output wires. This will permanently damage the sensors!



The sensor will be damaged if the data sheet specifications and maximum recommended feed voltage levels are exceeded!

## Compatibility with media (substances)

**SensoControl®** products which come into contact with the substance are not produced in an oil-free or fat-free environment.

Therefore these products are **not** suitable for use in applications which use explosive mixtures of oil and gas (e.g. oxygen or compression). This could lead to a danger of explosion!

## Danger of explosion!

Only use substances which are compatible with the components that come into contact with the substance. (Refer to the data sheets)

Please consult with the plant manufacturer or the manufacturer of the substance if you have any questions. (Refer to catalogue 4100 chapter C).

## Pressure range selection

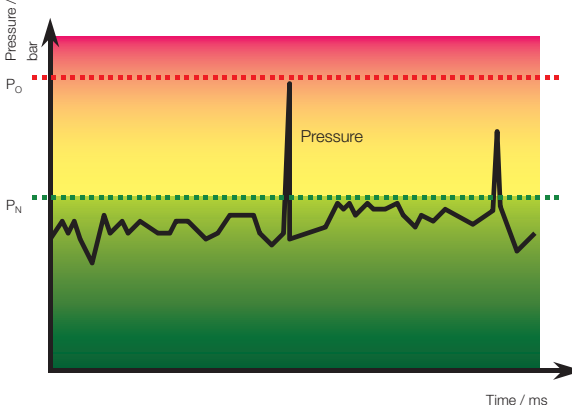

When selecting pressure components, ensure that the overload pressure  $P_{max}$  will not be exceeded.

It is possible that the pressure cell can be deformed when the overload pressure  $P_{max}$  is exceeded (depending on the duration, frequency and level of the pressure spike).

Note: The "diesel effect" caused by entrapped air can result in pressure spikes that far exceed the maximum pressure.

The nominal pressure  $P_N$  of the pressure component (sensor/switch) should be higher than the nominal pressure of the system to be measured.

# Appendix

## Temperature conversion table

Celsius to Fahrenheit

°C	°F
150	302
145	293
140	284
135	275
130	266
125	257
120	248
115	239
110	230
105	221
100	212
95	203
90	194
85	185
80	176
75	167
70	158
65	149
60	140
55	131
50	122
45	113
40	104
35	95
30	86
25	77
20	68
15	59
10	50
5	41
0	32
-5	23
-10	14
-15	5
-20	-4
-25	-13
-30	-22
-35	-31
-40	-40
-45	-49
-50	-58

Fahrenheit to celsius

°F	°C
340	171
330	166
320	160
310	154
300	149
290	143
280	138
270	132
260	127
250	121
240	116
230	110
220	104
210	99
200	93
190	88
180	82
170	77
160	71
150	66
140	60
130	54
120	49
110	43
100	38
90	32
80	27
70	21
60	16
50	10
40	4
30	-1
20	-7
10	-12
0	-18
-10	-23
-20	-29
-30	-34
-40	-40
-50	-46
-60	-51

## Pressure conversion table

bar to psi

bar	psi
1000	14505
800	11604
600	8703
500	7253
400	5802
250	3626
160	2321
100	1451
60	870
40	580
35	508
25	363
16	232
10	145
6	87
4	58
2.5	36
1.6	23
1	15

psi to bar

psi	bar
10000	689
9000	620
7000	483
6000	414
4000	276
3000	207
2500	172
1000	69
900	62
600	41
500	34
400	28
250	17
150	10.3
100	6.9
90	6.2
60	4.1
40	2.8
25	1.7
10	0.7

## Examples

### Temperature conversion

Initial value: 100  
 °C in °F: 212 °F  
 °F in °C: 37.78 °C

### Pressure conversion

Initial value: 35  
 bar in psi: 507.675 psi  
 psi in bar: 2.41296 bar

# Appendix

## Index

SCxSD	53-54	SCOTC-...	95-100
SC-910	38	SCP01-...	12-15
SC-911	38	SCP02-...	16-21
SC-912	38	SCP07	22-23
SCA-1/4EDX1/2-ED	103	SCP08	24-25
SCA-1/4EDX1/4-D	103	SCPS01-...	26-30
SCA-1/4-M22x1.5-ED	103	SCPSD-...	61-66
SCAF-1/4-40	104	SCPSDI-...	55-60
SCAF-3/4-90	104	SCQ-150-10-07	35-38
SCA-SMA3-...	101	SCSD-PRG-KIT	106
SCAQ-060	35-38	SCSD-S27	66
SCAQ-150	35-38	SCT-150-...	31-32
SCAQ-GI-R1/2	35-38	SCTSD-150-...	67-78
SCA-TT-10-1/2	74	SCTSD-L-...	79-82
SCA-TT-10-xxx	74	SCTT-10-xxx-07	74
SCE-020-02	49-52	SCTT-20-10-07	74
SCFT-...	39-42	SCVF-...	43-48
SCK-006	101-102		
SCK-145	101-102		
SCK-155	101-102		
SCK-300-02-31	52		
SCK-400-...	101-102		
SCK-410-03-45-45	74		
SCLSD-...	83-88		
SCLTSD-...	79-94		

## Old and new references

Old order number	New order number	Old order number	New order number
SCK-007	SCK-145	SCP-xxx-x4-0x-MO	SCP02-xxx-x4-0x
SCK-045	SCK-145	SCP-xxx-x4-0x	SCP01-xxx-x4-0x
SCK-047	SCK-145	SCP-xxx-10-06	SCP01-xxx-14-06 + SCA-1/4-M22x1.5-ED
SCK-055	SCK-155	SCP-xxx-10-07	SCP01-xxx-14-07 + SCA-1/4-M22x1.5-ED
SCK-057	SCK-155	SCP-xxx-12-06	SCP01-xxx-14-06 + SCA-1/4-ED-1/2-ED
SCK-147	SCK-145	SCP-xxx-12-07	SCP01-xxx-14-07 + SCA-1/4-ED-1/2-ED
SCK-157	SCK-155	SCP-xxx-20-06	SCP01-xxx-24-06 + SCA-1/4-M22x1.5-ED
SCK-200-xxx-45	SCK-400-xxx-45	SCP-xxx-20-07	SCP01-xxx-24-07 + SCA-1/4-M22x1.5-ED
SCK-200-xxx-47	SCK-400-xxx-45	SCP-xxx-22-06	SCP01-xxx-24-06 + SCA-1/4-ED-1/2-ED
SCK-200-xxx-55	SCK-400-..55	SCP-xxx-22-07	SCP01-xxx-24-07 + SCA-1/4-ED-1/2-ED
SCK-200-xxx-56	SCK400-xxx-56	SCP-xxx-30-06	SCP01-xxx-34-06 + SCA-1/4-M22x1.5-ED
SCK-200-xxx-57	SCK-400-..55	SCP-xxx-30-07	SCP01-xxx-24-07 + SCA-1/4-M22x1.5-ED
SCK-400-xxx-06	SCK-400-xxx-56	SCP-xxx-32-06	SCP01-xxx-34-06 + SCA-1/4-ED-1/2-ED
SCK-400-xxx-07	SCK-400-xxx-45	SCP-xxx-32-07	SCP01-xxx-24-07 + SCA-1/4-ED-1/2-ED
SCK-400-xxx-47	SCK-400-xxx-45	SCP-xxx-40-06	SCP01-xxx-44-06 + SCA-1/4-M22x1.5-ED
SCK-400-xxx-57	SCK-400-..55	SCP-xxx-40-07	SCP01-xxx-44-07 + SCA-1/4-M22x1.5-ED
SCPSD-xxx-04-05	SCPSD-xxx-04-17	SCP-xxx-42-06	SCP01-xxx-44-06 + SCA-1/4-ED-1/2-ED
SCPSD-xxx-04-06	SCPSD-xxx-04-16	SCP-xxx-42-07	SCP01-xxx-44-07 + SCA-1/4-ED-1/2-ED
SCPSD-xxx-04-07	SCPSD-xxx-04-17	SCT-150-14-00	SCT-150-14-07+SCK-400-05-45
SCPSD-xxx-14-05	SCPSD-xxx-14-15		

Please ask about compatible products for non-listed items.



